

**NASA CONTRACTOR
REPORT**

NASA CR-1850

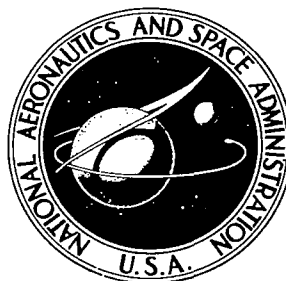

NASA CR
27

0061028



**LOAN COPY: RETURN TO
AFW L (DOGL)
KIRTLAND AFB, N. M.**

**SNAP-8 REFRACTORY BOILER
DEVELOPMENT - CORROSION OF OXYGEN
CONTAMINATED TANTALUM IN NaK**

by R. W. Harrison

Prepared by

GENERAL ELECTRIC COMPANY

Cincinnati, Ohio 45215

for Lewis Research Center

NATIONAL AERONAUTICS AND SPACE ADMINISTRATION • WASHINGTON, D. C. • JULY 1971



0061028

1. Report No. NASA CR-1850	2. Government Accession No.	3. Recipient's Catalog No.	
4. Title and Subtitle SNAP-8 REFRACTORY BOILER DEVELOPMENT - CORROSION OF OXYGEN CONTAMINATED TANTALUM IN NaK		5. Report Date July 1971	
		6. Performing Organization Code	
7. Author(s) R. W. Harrison		8. Performing Organization Report No. GESP-138	
		10. Work Unit No.	
9. Performing Organization Name and Address General Electric Company Cincinnati, Ohio 45215		11. Contract or Grant No. NAS 3-10610	
		13. Type of Report and Period Covered Contractor Report	
12. Sponsoring Agency Name and Address National Aeronautics and Space Administration Washington, D. C. 20546		14. Sponsoring Agency Code	
		15. Supplementary Notes	
16. Abstract <p>This program was conducted in support of the SNAP-8 Refractory Metal Boiler Development Program. It was observed that tantalum specimens with oxygen concentration of 270 ppm or greater are attacked by NaK at 1200⁰ and 1300⁰ F; that welding tantalum specimens in helium containing up to 250 ppm air had no observed effect on their corrosion resistance to NaK; and that reduction of the oxygen concentration of tantalum specimens occurred during NaK exposure, whether the specimens were attacked or not.</p>			
17. Key Words (Suggested by Author(s)) Alkali metal corrosion Tantalum SNAP-8 boiler		18. Distribution Statement Unclassified - unlimited	
19. Security Classif. (of this report) Unclassified	20. Security Classif. (of this page) Unclassified	21. No. of Pages 39	22. Price* \$3.00



FOREWORD

The research described in this report was conducted by the General Electric Company under NASA contract NAS 3-10610. Mr. Phillip L. Stone of the Lewis Research Center Materials and Structures Division was the NASA Project Manager. The report was originally issued as General Electric report GESP-138.

TABLE OF CONTENTS

	<u>Page No.</u>
I INTRODUCTION	1
II SUMMARY	3
III MATERIALS PROCUREMENT	4
IV SPECIMEN PREPARATION	4
V CAPSULE ASSEMBLY	10
VI CAPSULE FILLING	10
VII TEST FACILITY	14
VIII POSTTEST EVALUATION	14
A. Weight Change Measurements	14
B. Bend Tests	17
C. Metallographic Examination	17
1. Effect of Oxygen Concentration in Tantalum on Corrosion.	17
2. Effects of Welding and Welding Atmosphere Purity on the Morphology of Corrosion in Oxygen Contaminated Tantalum.	17
3. Effects of NaK Temperature and Exposure Time on Corrosion of Oxygen Contaminated Tantalum.	24
D. Microhardness Measurements and Chemical Analysis	24
1. Effects of NaK Exposure on the Hardness and Oxygen Concentration of Unwelded Oxygen Contaminated Tantalum	24
2. Effects of Welding on the Hardness and Oxygen Concentration of Oxygen Contaminated Tantalum.	28
a. Before NaK Exposure.	28
b. After Exposure to NaK.	28
3. Effects of NaK Temperature and Exposure Time on the Oxygen Concentration and Microhardness of Oxygen Contaminated Tantalum	28
IX OBSERVATIONS	32
X REFERENCES	33

LIST OF ILLUSTRATIONS

<u>Figure No.</u>		<u>Page No.</u>
1	High Vacuum System (10^{-10} Torr Range) Used for the Contamination of Tantalum Specimens. The Chamber is 24 Inches in Diameter and 54 Inches High and Incorporates a 1000 Liter/Sec Getter-Ion Pump. The Oxygen Partial Pressure is Controlled by a Variable Leak. . . .	6
2	Schematic Diagram of the High Vacuum Chamber and Components Used for Contaminating Tantalum Specimens.	7
3	Vacuum Purge Inert Gas Welding Chamber.	9
4	Tantalum Capsule and Specimens Before Assembly and Filling with NaK	11
5	30KV Electron Beam Welding Chamber and Controls Used to Fill Corrosion Capsules with Alkali Metals	12
6	Internal View of Facility Showing the Components Required to Fill Capsules with Alkali Metals	13
7	Test Facility for Isothermal Corrosion Capsule Tests.	15
8	Bend Ductility of Welded Tantalum Specimens Following Exposure to NaK for 100 Hours at 1200°F . All Specimens were Bent 120° Using an Anvil with a 1.5T Radius. Cracks in Specimens d. and h. Exposed to NaK Were Not Evidenced in the Similar As-Welded Specimens and Were a Result of Corrosion	18
9	Cracks in the Heat Affected Zone and Weld Area of an 0.5-Inch Wide Welded Tantalum Specimen Containing 520 ppm Oxygen and Bent 120° (1.5t) After 1000 Hours Exposure to NaK at 1350°F	19
10	Corrosion in Unwelded Tantalum Contaminated with 520 ppm Oxygen and Exposed to NaK for 1000 Hours at 1350°F	20
11	Corrosion in Tantalum Specimens Contaminated with 270 ppm Oxygen and Exposed to NaK for 1000 Hours at 1350°F	21
12	Corrosion in the Heat Affected Zone of Tantalum Specimens Contaminated with 520 ppm Oxygen, Welded, and Exposed to NaK for 1000 Hours at 1350°F	22
13	Corrosion in the Weld of Tantalum Specimens Contaminated with 520 ppm Oxygen, Welded, and Exposed to NaK for 1000 Hours at 1350°F	23
14	Corrosion in the Heat Affected Zone of Tantalum Specimens Contaminated with 520 ppm Oxygen Welded in Helium Containing 250 ppm Air and Exposed to NaK.	25

LIST OF ILLUSTRATIONS (Continued)

Figure No.

- 15 Hardness of Tantalum as a Function of Oxygen Concentration
- 16 Microhardness Profiles in the Heat Affected Zones of Weld Specimens Containing 520 ppm Oxygen Before and After Exposure to NaK.

LIST OF TABLES

<u>Table No.</u>		<u>Page No.</u>
I	Chemical Analysis ^(a) of As-Received Tantalum Materials	5
II	Oxygen Contamination of Pure Tantalum at 2400°F in a 1×10^{-6} Torr Pressure Maintained by an Oxygen Leak.	8
III	Corrosion of Oxygen Contaminated Tantalum Specimens Exposed to NaK in Tantalum Capsules	16
IV	Oxygen Concentration and Microhardness of Unwelded Tantalum Specimens Exposed to NaK for 1000 Hours at 1350°F	27
V	Oxygen Concentration of Tantalum Specimens Exposed to NaK for 1000 Hours at 1350°F.	29

I. INTRODUCTION

In recent experiments at the Oak Ridge National Laboratory, gross corrosion of unalloyed tantalum thermocouple tube sheaths by NaK has been noted⁽¹⁾. The attack, which penetrated the 7-mil thick tantalum tube wall in less than five hours at a temperature of 500 to 600°F, has been tentatively attributed to oxygen contamination of the tube wall while making the end closure weldments. Other investigators^(2,3) who have evaluated the compatibility of refractory metal alloys in potassium and sodium have concluded that the addition of strong oxide forming elements to the refractory metal has a beneficial effect on the compatibility of the alloy with the alkali metals. Although pure tantalum has excellent resistance to attack at elevated temperatures by high-purity potassium, its corrosion resistance is drastically reduced by small amounts of oxygen impurity in the tantalum or the potassium⁽⁴⁾.

Since the NaK in the thermal bond annulus of the SNAP-8 boiler is in contact with both tantalum tubing and weldments, it was important to determine the effect of the oxygen concentration of tantalum on its corrosion resistance to NaK. Tantalum specimens with homogeneous oxygen concentrations ranging from 50-500 ppm were prepared by contamination at low pressure and subsequently exposed to NaK at 1350°F for 1000 hours to determine the threshold oxygen concentration for corrosion. Additional contaminated and uncontaminated specimens were welded in pure helium

and helium contaminated with air to evaluate the combined effects of welding, welding gas purity, and pre-weld oxygen concentration of the tantalum on the corrosion resistance of the tantalum to NaK. Some specimens were also exposed at 1200°F for 100 hours to determine the effects of temperature and time on corrosion.

II. SUMMARY

1. Tantalum specimens with oxygen concentrations of 270 ppm or greater were attacked by NaK at 1200°F and 1350°F.
2. Welding contaminated tantalum specimens changed the morphology of the NaK corrosion.
3. Welding contaminated tantalum specimens yielded weld nuggets having lower oxygen concentration than the parent sheet. Greater oxygen reductions were observed when the specimens were welded in pure helium than in helium containing 250 ppm air.
4. Welding tantalum specimens in helium containing up to 250 ppm air had no observed effect on their corrosion resistance to NaK.
5. Reduction of the oxygen concentration of tantalum specimens occurred during NaK exposure, whether the specimens were attacked or not. The oxygen reductions noted were higher at 1350°F than at 1200°F.

III. MATERIALS PROCUREMENT

Tantalum 0.040-inch thick sheet for specimens and 1-inch OD x 0.100-inch thick wall tube for capsules were obtained from National Research Corporation, Newton, Mass. Both lots of material were recrystallized with a grain size of ASTM-7. The chemical analyses shown in Table I were within the specifications, NSP specification no. 01-0074-00-A for the tube and ASTM 364-62T (with less than 10 ppm hydrogen) for the sheet.

IV. SPECIMEN PREPARATION

Oxygen contaminated tantalum specimens were prepared in the 24-inch diameter by 54-inch high Varian high vacuum system shown in Figure 1. The 0.040-inch thick specimens measuring 1-inch wide x 22-inch long were heated by direct resistance, and the temperature was monitored with W-3Re/W-25Re thermocouples. A schematic of the test set-up is shown in Figure 2. The chamber was initially evacuated by means of a 260 liter/sec turbomolecular pump. Following bakeout of the system, a cold wall pressure of 1.5×10^{-9} torr was achieved. The specimens were heated to 2400°F and held at a 1×10^{-6} torr pressure maintained by means of an oxygen leak. The oxygen partial pressures during each run were determined by means of the GE partial pressure gas analyzer shown in Figure 1. Specimens containing four concentration levels of oxygen as shown in Table II were prepared in this manner.

Oxygen contaminated tantalum specimens and pure tantalum specimens were welded in pure helium, helium containing 50 ppm air, and helium containing 250 ppm air respectively. The welding was performed by the automatic TIG process in the vacuum purge inert gas welding chamber shown in Figure 3. A complete penetration fusion pass was made on each specimen. The chamber was evacuated to less than 8×10^{-6} torr prior to backfilling with purified helium containing 1 ppm oxygen.

TABLE I. CHEMICAL ANALYSIS^(a) OF AS-RECEIVED
TANTALUM MATERIALS

Element	Concentration, ppm	
	Tube (b)	Sheet (c)
B	<1	<1
Al	<10	<10
Cr	<1	<1
Cu	<1	<1
Hf	<50	<50
Fe	15	8
V	<5	<5
Zr	<50	<50
Sn	<1	<1
Mo	<10	<10
Nb	<25	25
Pb	<1	<1
Ni	11	4
Mn	<1	<1
Si	15	12
Mg	<1	<1
Ti	<5	<5
Co	<5	<5
W	<40	<40
Ca	<25	<25
O (d)	58	55
N (d)	12	47
H (d)	1	1
C (e)	36	24

(a) Vendors Spectrographic analysis, except as designated

(b) MCN-09-038-(1-20), 1-inch OD x 0.100-inch thick wall

(c) MCN-09-036-(1-4), 0.040-inch thick

(d) Vacuum Fusion, NSP

(e) Combustion Conductometric, NSP

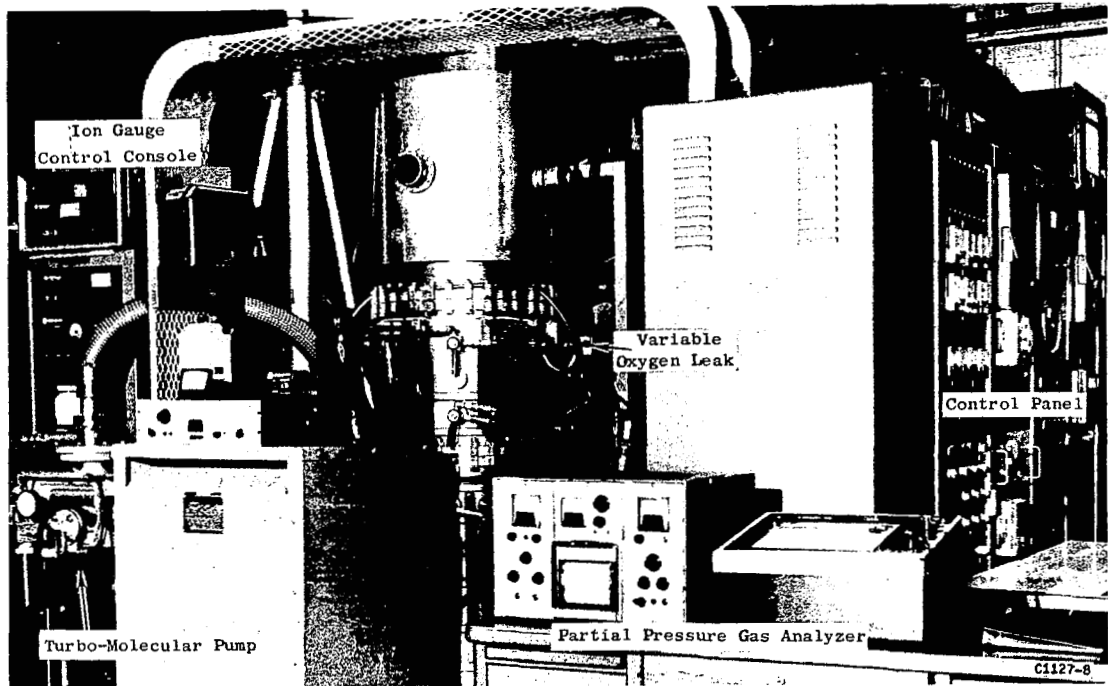

Figure 1. High Vacuum System (10^{-10} Torr Range) Used for the Contamination of Tantalum Specimens. The Chamber is 24 Inches in Diameter and 54 Inches High and Incorporates a 1000 Liter/Sec Getter-Ion Pump. The Oxygen Partial Pressure is Controlled by a Variable Leak. (Orig. C66080914)

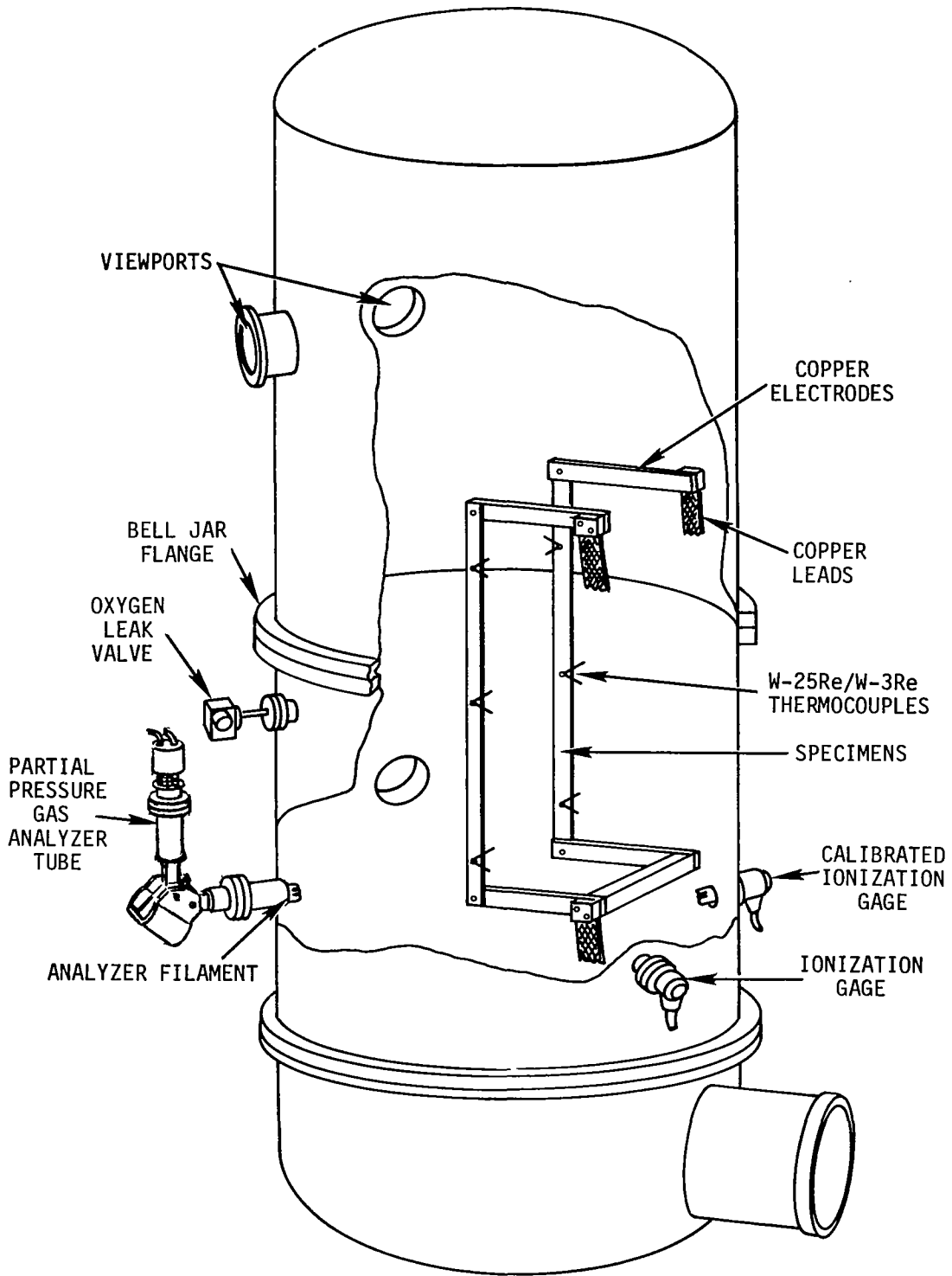

Figure 2. Schematic Diagram of the High Vacuum Chamber and Components Used for Contaminating Tantalum Specimens.

TABLE II. OXYGEN CONTAMINATION OF PURE TANTALUM
 AT 2400°F IN A 1×10^{-6} TORR PRESSURE
 MAINTAINED BY AN OXYGEN LEAK

OXYGEN PARTIAL PRESSURE, TORR	EXPOSURE TIME, HOURS	OXYGEN CONCENTRATION, ppm IN TANTALUM	
		PICKUP	TOTAL
5.2×10^{-7}	7	51	115
5.8×10^{-7}	11	145	220
4.8×10^{-7}	21	220	270
5.2×10^{-7}	39	445	520

Average contamination rate $5.4 \text{ mg cm}^{-2} \text{ sec}^{-1} \text{ torr}^{-1}$

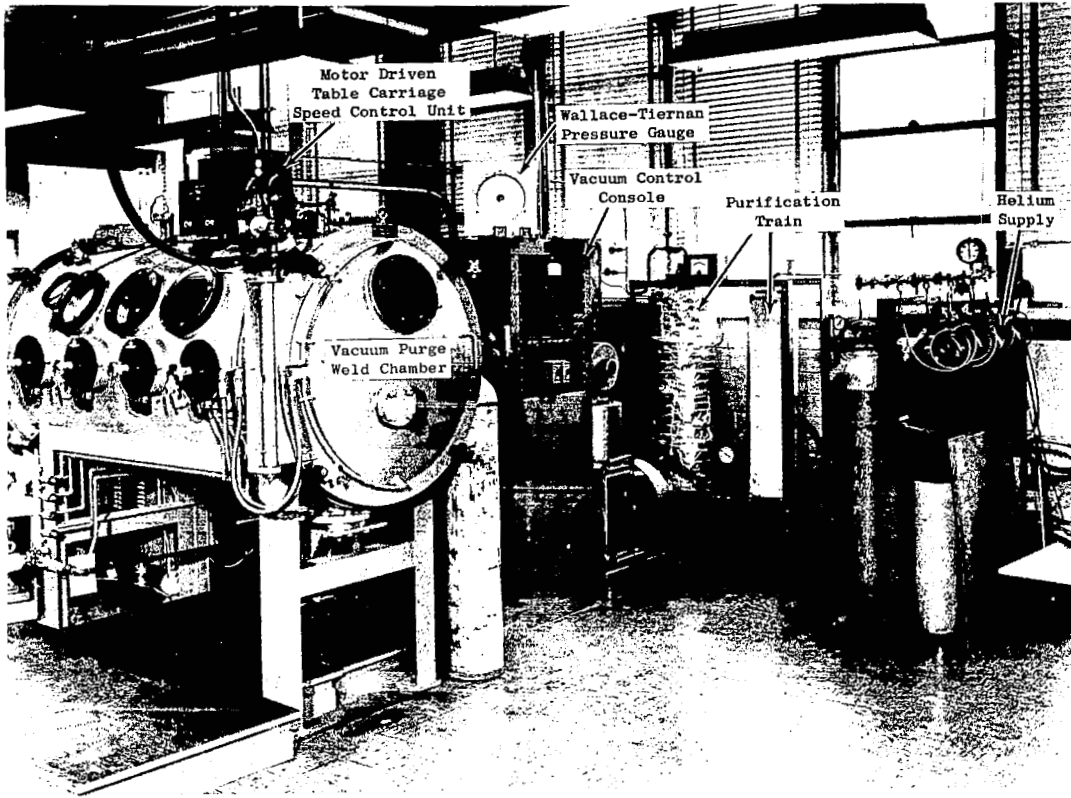

Figure 3. Vacuum Purge Inert Gas Welding Chamber. (Orig. C64102070)

The helium was purified by passing through a two-stage purification train. Stage one contained a molecular sieve dryer for moisture removal. Stage two contained titanium turnings heated to 1460°F for removal of oxygen and nitrogen. The welding chamber purification and analysis system is described in detail in a topical report⁽⁵⁾. The air contaminated welding atmospheres were produced introducing a measured amount of air. The contamination level was then verified with the mass spectrometer analysis system.

V. CAPSULE ASSEMBLY

The specimens for exposure to NaK were suspended from a tantalum wire holder in a tantalum capsule, shown in Figure 4. A maximum of eight specimens were placed in each capsule individually separated from each other with tantalum wire spacers to allow free access to the NaK on all surfaces. The weight of each specimen was recorded before capsule assembly for comparison with posttest results.

VI. CAPSULE FILLING

The capsules were filled with NaK^(a) in the electron beam welding chamber, shown in Figure 5, at a pressure of 2.5×10^{-5} torr.

A similar capsule filling set-up to that employed is shown in Figure 6. After filling with NaK, each capsule was rotated under a manipulator which was used to position the capsule cap. The manipulator penetrates the chamber through a sliding O-ring seal in a Varian Con-Flat flange. The capsules were positioned under the EB welding gun by means of a flexible cable in conjunction with the table drive. The gear on each capsule was thus adjusted to mesh with the welding drive gear such that the capsule could be rotated around its axis during welding. This gear is controlled by a variable speed motor which can be adjusted to obtain the optimum welding speed. Copper chill blocks

(a) 22Na-78K, (weight percent).

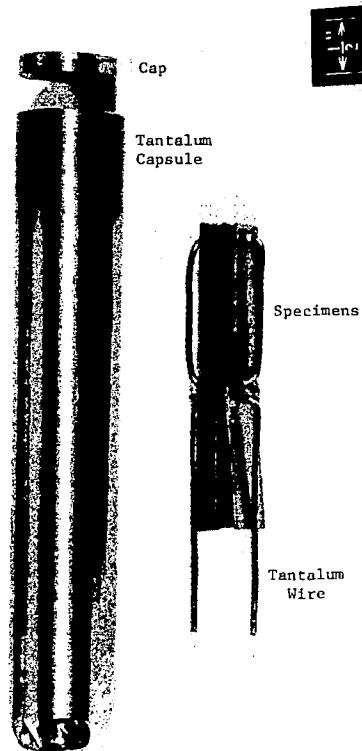

Figure 4. Tantalum Capsule and Specimens Before Assembly and Filling With NaK. (Orig. C67101024)

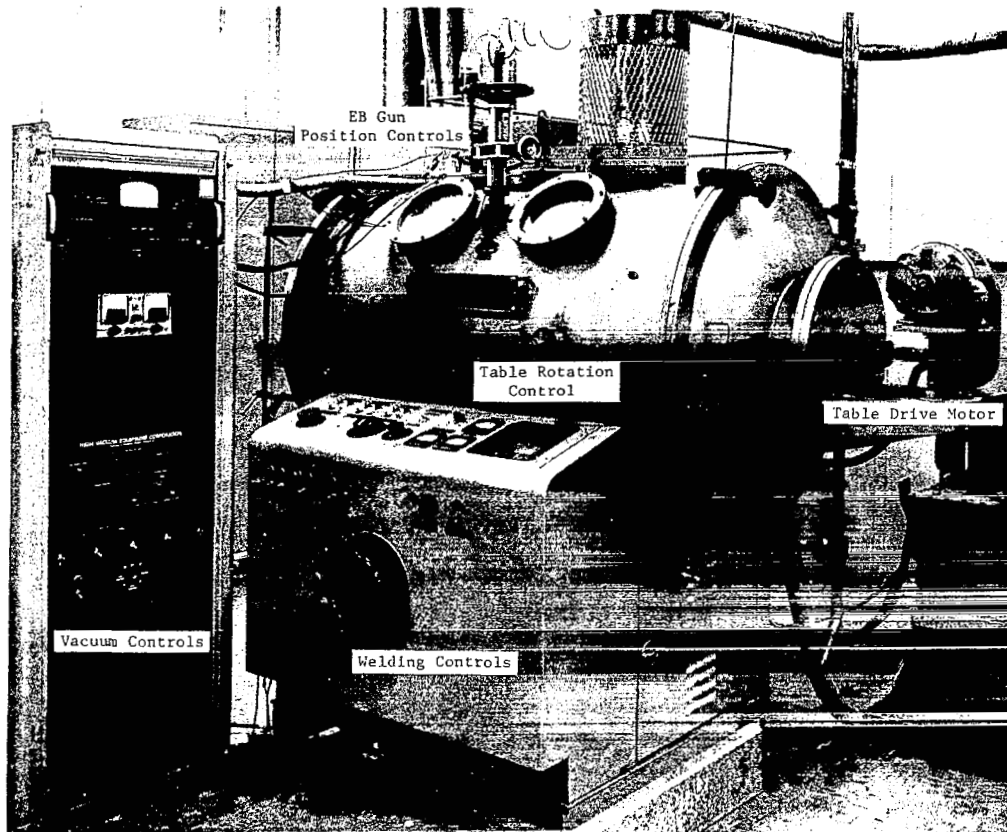

Figure 5. 30KV Electron Beam Welding Chamber and Controls Used to Fill Corrosion Capsules with Alkali Metals. (Orig. C64121619)

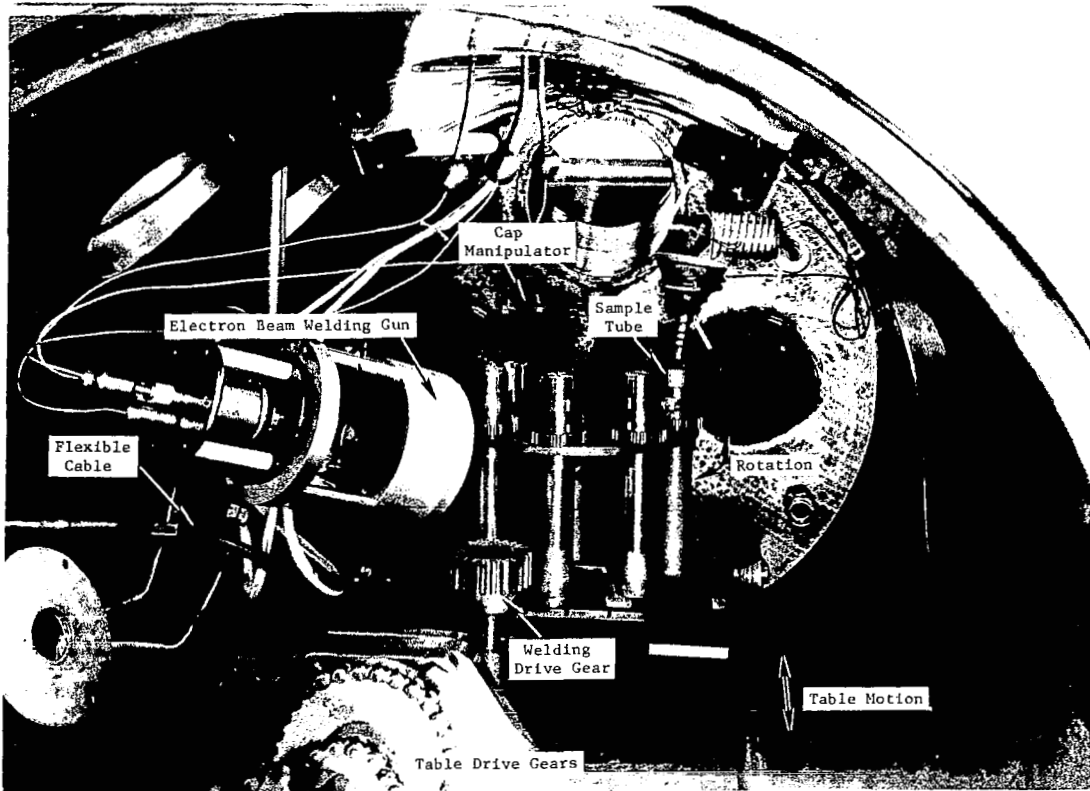

Figure 6. Internal View of Facility Showing the Components Required to Fill Capsules with Alkali Metals. (Orig. C64121620)

were fitted to each capsule to reduce the heat conduction along the capsules during welding and thereby reducing the vaporization of the NaK during welding.

After sealing the capsules, a sample of NaK was taken and subsequently analyzed by the mercury amalgamation method; a 10 ppm oxygen concentration was found. The tantalum capsules were sealed under vacuum in the electron beam chamber inside stainless steel tubular containers to protect the tantalum from oxidation during testing.

VII. TEST FACILITY

The capsules were heated in the test facility shown in Figure 7. Each capsule was heated by 1340-watt nichrome-wound resistance elements controlled with General Electric Volt-Pac 9H60 variable transformers. The temperature of the capsules was monitored with chromel-alumel thermocouples attached to the capsule wall (two per capsule). Temperature data was recorded continuously on an 8-point recorder.

VIII. POSTTEST EVALUATION

A total of twenty-eight tantalum specimens, as listed in Table III, were exposed to NaK in tantalum capsules. The specimens were removed from the capsules in a helium environment and cleaned of residual NaK by reaction with liquid ammonia. The effects of the exposure to NaK were evaluated by weight change measurements, bend tests, metallographic examination, microhardness measurements, and chemical analysis.

A. Weight Change Measurements

The cleaned tantalum specimens were weighed after exposure to NaK for 1000 hours at 1350°F, and the weights compared with the pretest weights. All specimens lost weight as can be seen in the results presented in Table III. The results also indicate the higher the initial oxygen concentration of the tantalum specimens, the greater the weight loss. Similar weight losses were found for welded and unwelded specimens of similar oxygen concentration.

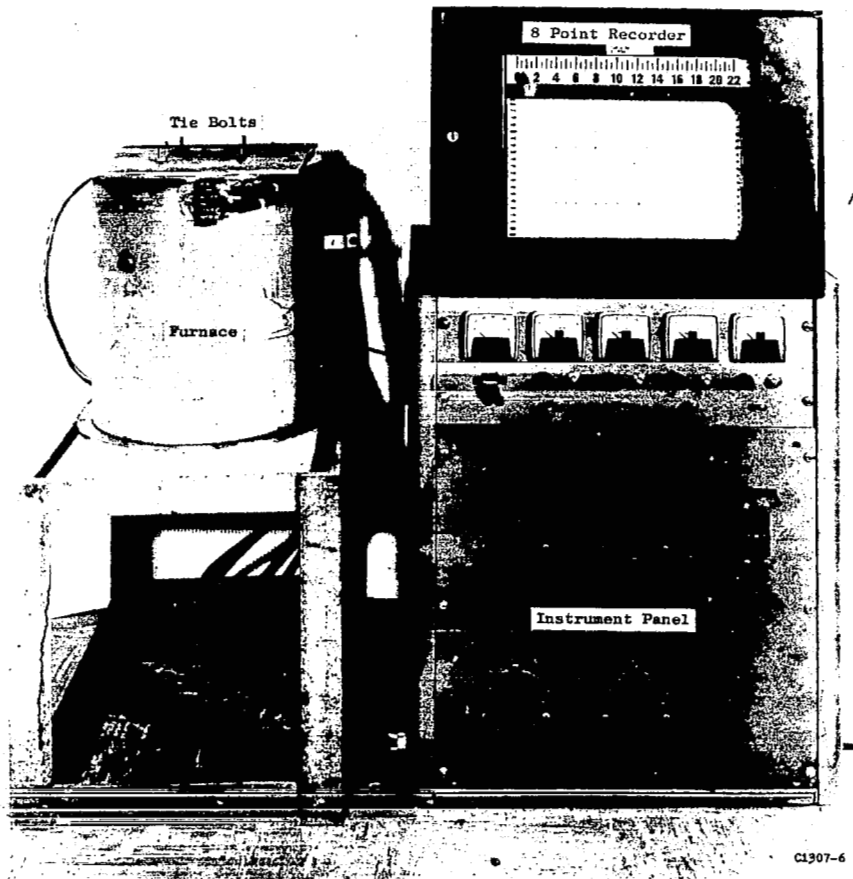

Figure 7. Test Facility for Isothermal Corrosion Capsule Tests.
(Orig. C64121039)

TABLE III. CORROSION OF OXYGEN CONTAMINATED
TANTALUM SPECIMENS EXPOSED TO NaK
IN TANTALUM CAPSULES

Specimen Condition	Oxygen Concentration, ppm	Welding Atmosphere	NaK Exposure		Depth of Attack, mils (a)	Weight Loss mg (b)
			Temperature, °F	Time, Hrs		
As-Received	55	Not Welded	1350	1000	No Attack	1.5
As-Received	55	He	1350	1000	No Attack	1.9
As-Received	55	He + 50 ppm Air	1200	100	No Attack	-
As-Received	55	He + 50 ppm Air	1350	1000	No Attack	2.6
As-Received	55	He + 250 ppm Air	1200	100	No Attack	-
As-Received	55	He + 250 ppm Air	1350	1000	No Attack	2.1
Oxygen Contaminated	115	Not Welded	1350	1000	No Attack	3.6
Oxygen Contaminated	115	He	1350	1000	No Attack	5.0
Oxygen Contaminated	115	He + 50 ppm Air	1200	100	No Attack	-
Oxygen Contaminated	115	He + 50 ppm Air	1350	1000	No Attack	4.8
Oxygen Contaminated	115	He + 250 ppm Air	1200	100	No Attack	-
Oxygen Contaminated	115	He + 250 ppm Air	1350	1000	No Attack	4.7
Oxygen Contaminated	220	Not Welded	1350	1000	No Attack	7.8
Oxygen Contaminated	220	He	1350	1000	No Attack	6.7
Oxygen Contaminated	220	He + 50 ppm Air	1350	1000	No Attack	8.7
Oxygen Contaminated	220	He + 250 ppm Air	1350	1000	No Attack	9.1
Oxygen Contaminated	270	Not Welded	1350	1000	2	9.1
Oxygen Contaminated	270	He	1350	1000	3	8.4
Oxygen Contaminated	270	He + 50 ppm Air	1200	100	4	-
Oxygen Contaminated	270	He + 50 ppm Air	1350	1000	3	11.3
Oxygen Contaminated	270	He + 250 ppm Air	1200	100	4	-
Oxygen Contaminated	270	He + 250 ppm Air	1350	1000	3	11.6
Oxygen Contaminated	520	Not Welded	1350	1000	10	20.5
Oxygen Contaminated	520	He	1350	1000	8	17.6
Oxygen Contaminated	520	He + 50 ppm Air	1200	100	20(c)	-
Oxygen Contaminated	520	He + 50 ppm Air	1350	1000	8	19.4
Oxygen Contaminated	520	He + 250 ppm Air	1200	100	20(c)	-
Oxygen Contaminated	520	He + 250 ppm Air	1350	1000	8	20.0

(a) In the Heat Affected Zone adjacent to the weld nugget

(b) Specimen weights, 10-11 grams

(c) Complete penetration of 0.040-inch thick sheet specimen

B. Bend Tests

The 0.040 inch thick tantalum sheet specimens were bent 120° using an anvil with a radius of 0.0625 inch (1.5 t) to qualitatively document the effects of the NaK exposure on bend ductility. The results for the specimens exposed to NaK for 100 hours at 1200°F are shown in Figure 8. All specimens including those exposed to NaK at 1350°F exhibited ductile behavior. Cracks were noted in the heat affected zone and weld areas of the NaK exposed specimens containing 520 ppm oxygen as indicated in Figure 8 for the 1200°F exposure and Figure 9 for the 1350°F exposure. Similar specimens bent in the as-welded condition (not exposed to NaK) were uncracked. The cracks can be attributed to corrosion which was subsequently delineated in metallographic examination.

C. Metallographic Examination

1. Effect of Oxygen Concentration in Tantalum on Corrosion

Transverse sections of the NaK exposed tantalum specimens were examined in the as-polished and etched conditions and compared with similar specimens which had not been exposed to NaK. Evidence of corrosion was found in tantalum specimens containing 270 ppm and 520 ppm oxygen respectively. The maximum depth of attack in an unwelded tantalum specimen containing 520 ppm oxygen was measured to be approximately 10 mils (0.010 inch) as shown in Figure 10. No corrosion was detected in specimens with oxygen concentrations of 220 ppm or less.

2. Effects of Welding and Welding Atmosphere Purity on the Morphology of Corrosion in Oxygen Contaminated Tantalum

Welding contaminated tantalum specimens significantly changes the morphology of the corrosion. For specimens containing 270 ppm oxygen, corrosion in the heat affected zone and weld areas of welded specimens is about equal in magnitude and is more severe than base metal corrosion, as can be seen in Figure 11. For specimens containing 520 ppm oxygen, corrosion in the heat affected zone is less severe than that in the weld nugget as exemplified in Figures 12 and 13. Attack in the heat affected zone was approximately 8 mils deep as shown in Figure 12; whereas, complete penetration is evidenced in the weld nugget seen in Figure 13. The more extensive penetration in the weld area can be attributed to the

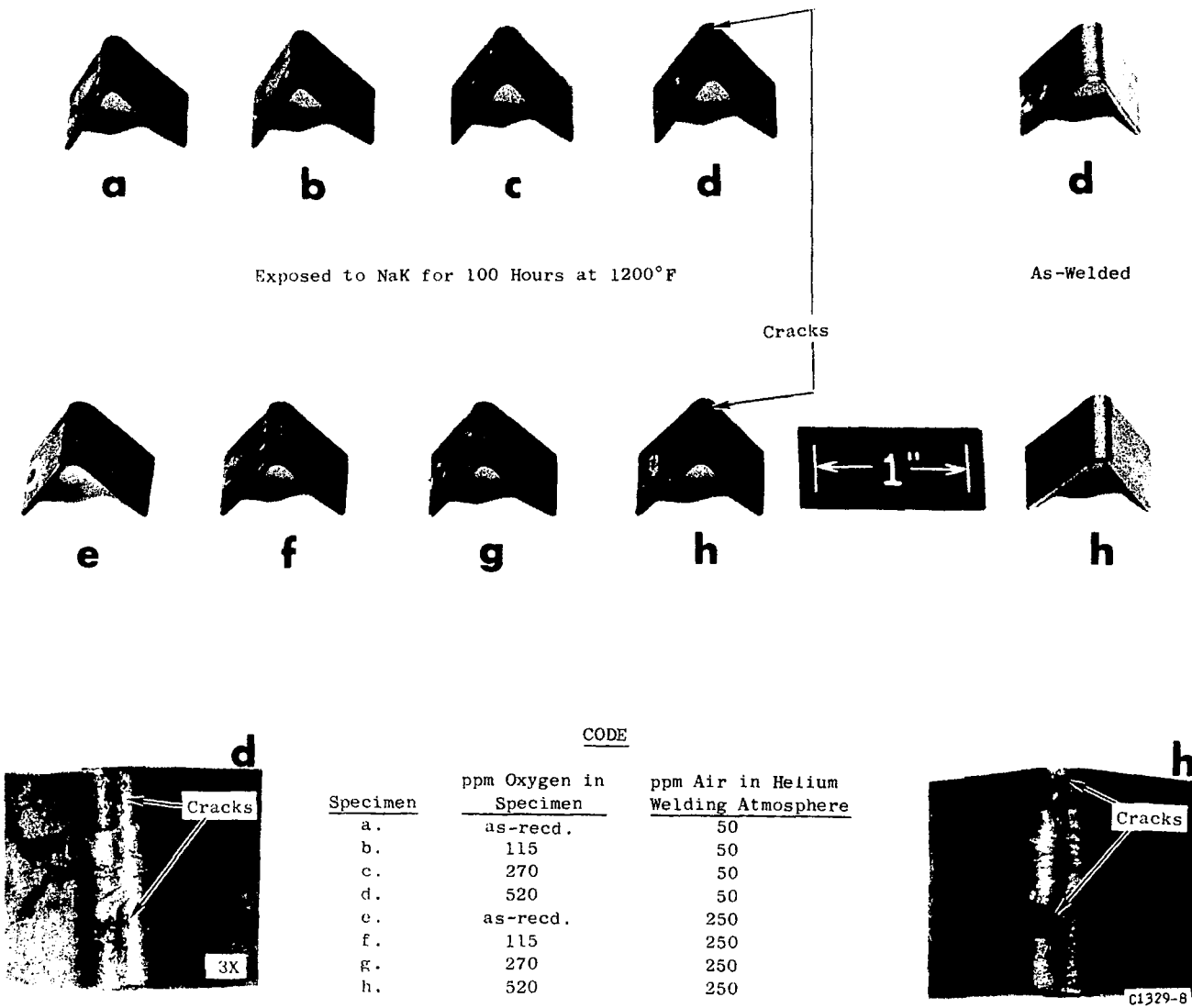

Specimen	CODE	
	ppm Oxygen in Specimen	ppm Air in Helium Welding Atmosphere
a.	as-recd.	50
b.	115	50
c.	270	50
d.	520	50
e.	as-recd.	250
f.	115	250
g.	270	250
h.	520	250

Figure 8 Bend Ductility of Welded Tantalum Specimens Following Exposure to NaK for 100 Hours at 1200°F. All Specimens Were Bent 120° Using an Anvil with a 1.5T Radius. Cracks in Specimens d and h. Exposed to NaK Were Not Evidenced in the Similar As-Welded Specimens and Were a Result of Corrosion. (C671029123) (C671029122)

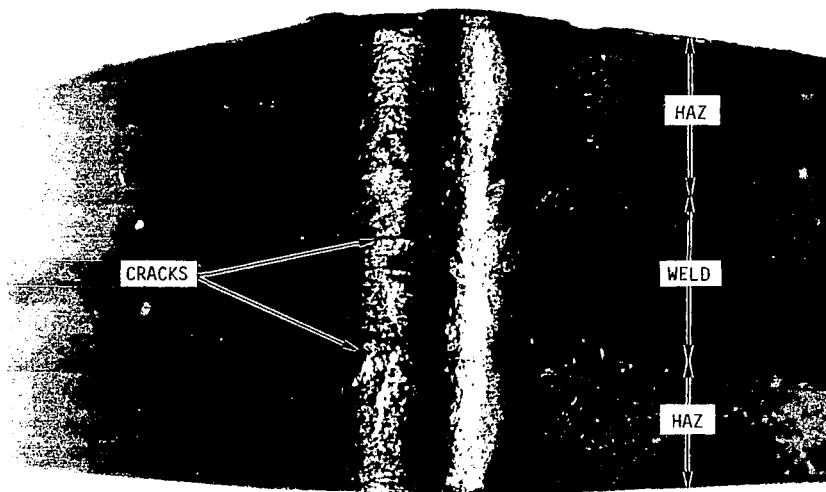
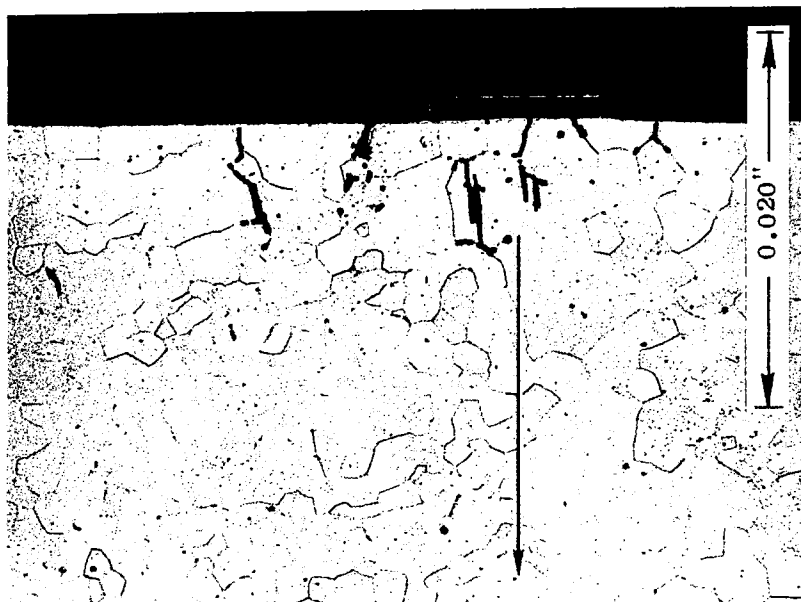
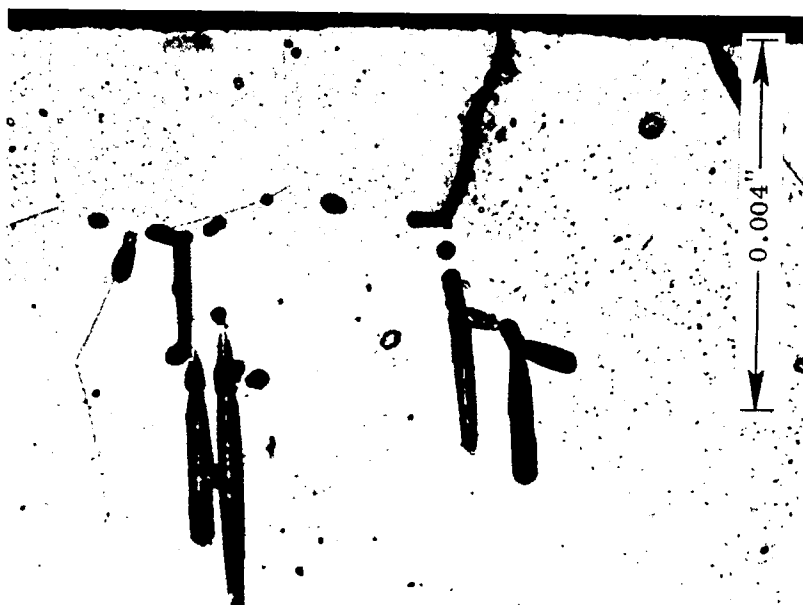

Figure 9. Cracks in the Heat Affected Zone and Weld Area of an 0.5-Inch Wide Welded Tantalum Specimen Containing 520 ppm Oxygen and Bent 120° (1.5t) After 1000 Hours Exposure to NaK at 1350°F. (Orig. C68013032) Mag: 8X



Mag: 100X
(F320122)



Mag: 500X
(F320121)

Figure 10. Corrosion in Unwelded Tantalum Contaminated with 520 ppm Oxygen and Exposed to NaK for 1000 Hours at 1350°F.

Etchant: 30gm NH_4F , 50 ml HNO_3 , 20 ml H_2O

Base Metal
(Unwelded Specimen)

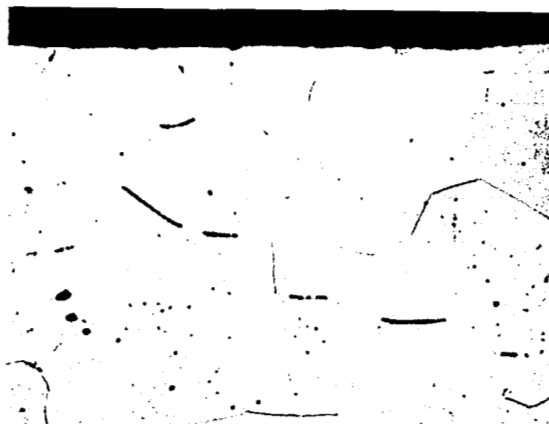

Heat Affected Zone
(Welded Specimen)



Weld

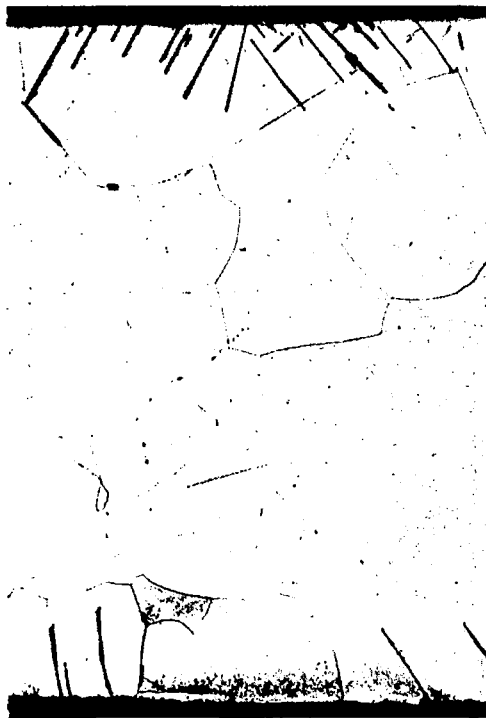

Figure 11. Corrosion in Tantalum Specimens Contaminated with 270 ppm Oxygen and Exposed to NaK for 1000 Hours at 1350°F.

Etchant: 30gm NH_4F , 50 ml HNO_3 , 20 ml H_2O Mag: 500X



Welded in Pure Helium
(F320142)



Welded in Helium & 50 ppm Air
(F320822)



Welded in Helium & 250 ppm Air
(F320842)

Figure 12. Corrosion in the Heat Affected Zone of Tantalum Specimens Contaminated with 520 ppm Oxygen, Welded, and Exposed to NaK for 1000 Hours at 1350°F.

Etchant: 30gm NH_4F , 50 ml HNO_3 , 20 ml H_2O

Mag: 100X

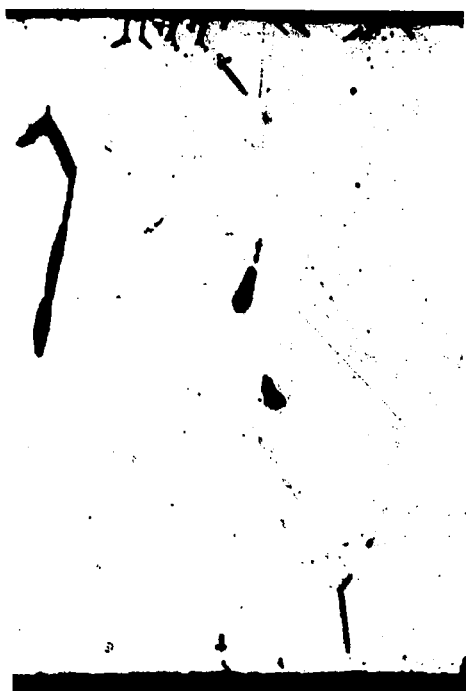

Welded in Pure Helium
(F320141)



Welded in Helium & 50 ppm Air
(F320821)

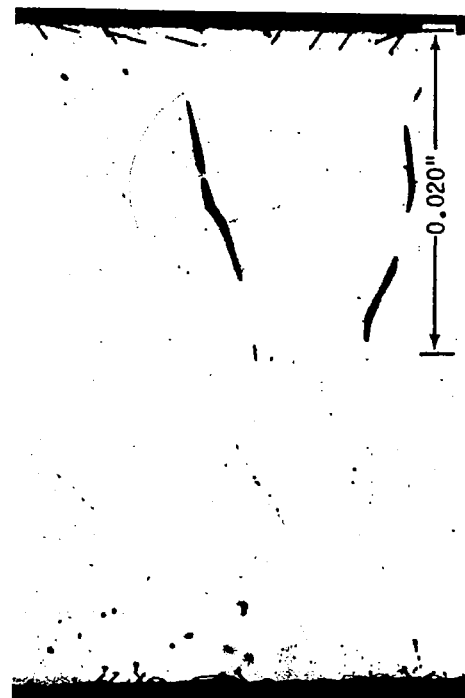

Welded in Helium & 250 ppm Air
(F320841)

Figure 13. Corrosion in the Weld of Tantalum Specimens Contaminated with 520 ppm Oxygen, Welded, and Exposed to NaK for 1000 Hours at 1350°F.

Etchant: 30gm NH₄F, 50 ml HNO₃, 20 mo H₂O

Mag: 100X

large grain size and the concomitant long transverse grain boundaries which facilitate deep penetration. Some grain boundaries in fact extended completely across the 0.040 inch thick specimens. It should also be noted in Figures 12 and 13 that up to 250 ppm air contamination in the helium welding atmosphere had no discernable effect on the extent of corrosion either in the weld or heat affected zone areas of the specimens. However, it should be noted that the test was for experimental analysis of the effect of procedures that may have to be used due to system restraints and that welding should normally be accomplished in the best atmosphere obtainable.

3. Effects of NaK Temperature and Exposure Time on Corrosion of Oxygen Contaminated Tantalum

The depth of attack in specimens that exhibited corrosion after exposure to NaK for 100 hours at 1200°F was greater than similar specimens exposed for 1000 hours at 1350°F as indicated in Table III. As an example, exposure to NaK at 1200°F resulted in complete penetration of the heat affected zone of welded specimens (0.040 inch thick) containing 520 ppm oxygen, as shown in Figure 14; whereas similar specimens exposed at 1350°F were attacked to a depth of only 8 mils.

D. Microhardness Measurements and Chemical Analysis

1. Effects of NaK Exposure on the Hardness and Oxygen Concentration of Unwelded Oxygen Contaminated Tantalum

Microhardness traverses were made on specimens before and after exposure to NaK. Nine equally spaced impressions were measured across the specimen thickness (0.040 inch). No hardness gradients were observed in specimens before NaK exposure, indicating that homogeneous oxygen concentrations had been produced during contamination. Hardness increased with increasing oxygen concentration in specimens unexposed to NaK as shown in Figure 15. The hardness of and oxygen concentration in all unwelded specimens was reduced to approximately the same level after exposure to NaK for 1000 hours at 1350°F as shown in Table IV. This reduction in oxygen concentration occurred without corrosion in specimens containing less than 270 ppm oxygen before exposure to NaK. This oxygen dissolution of refractory metals by alkali metals has been shown by other investigators to occur similarly in tantalum and columbium exposed to lithium^(6,7) and columbium exposed to potassium⁽⁸⁾.



Exposed to NaK for
100 hrs at 1200°F
(E951612)

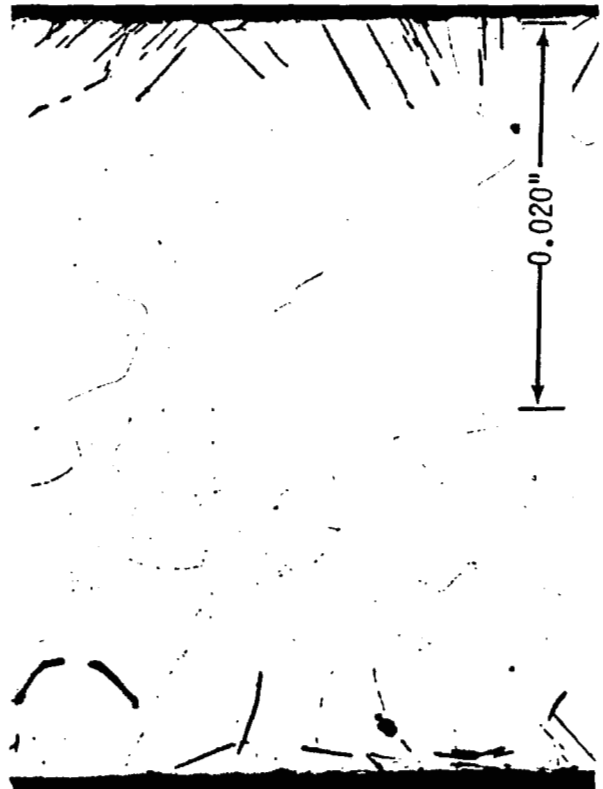

Exposed to NaK for
1000 hrs at 1350°F
(F320842)

Figure 14. Corrosion in the Heat Affected Zone of Tantalum Specimens Contaminated with 520 ppm Oxygen, Welded in Helium Containing 250 ppm Air and Exposed to NaK.

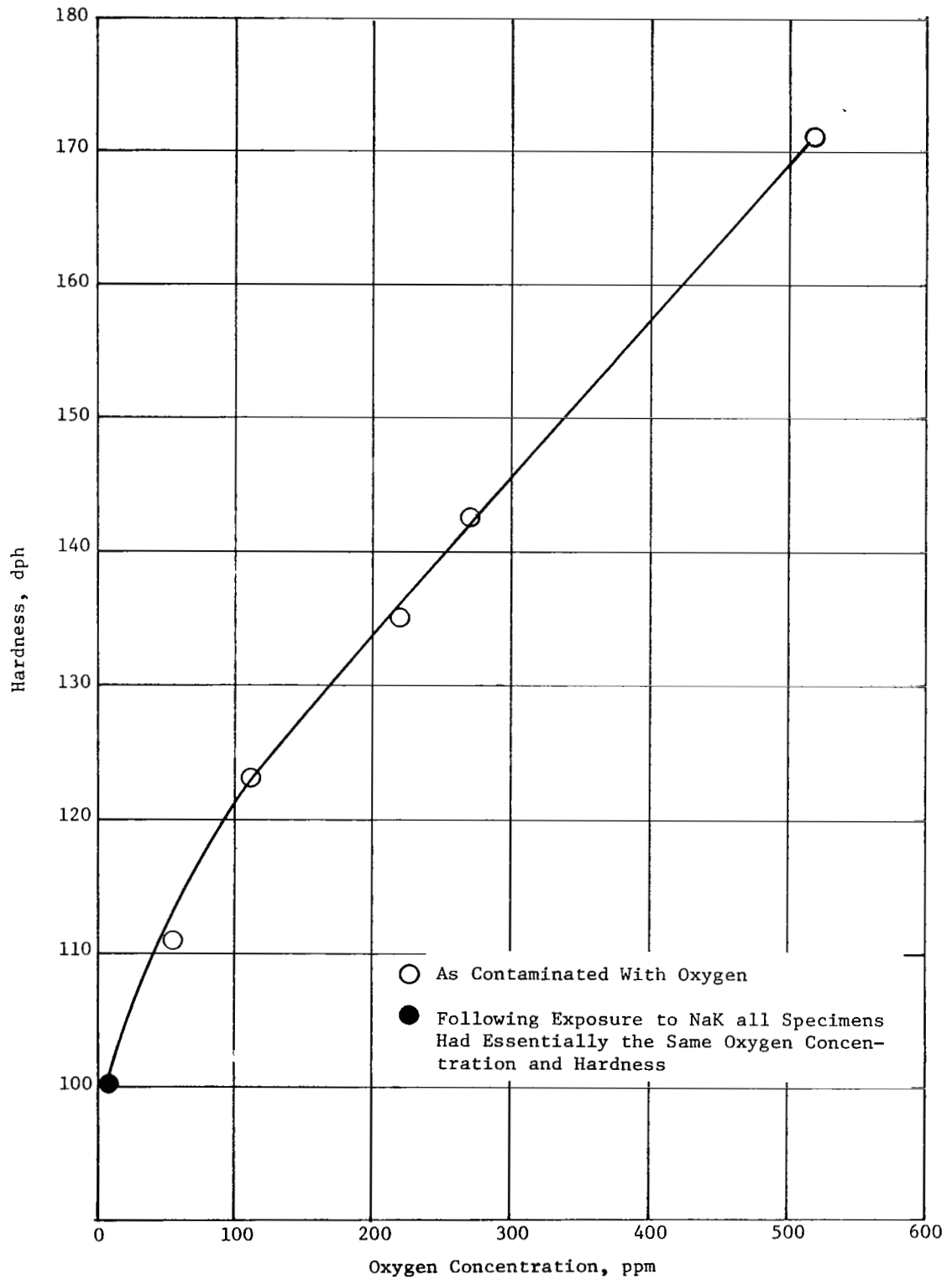

Figure 15. Hardness of Tantalum as a Function of Oxygen Concentration.

TABLE IV. OXYGEN CONCENTRATION AND MICROHARDNESS OF UNWELDED
TANTALUM SPECIMENS EXPOSED TO NaK FOR 1000 HOURS AT 1350°F.

Specimen	Oxygen Concentration, ppm ^(a)		Microhardness, DPH ^(b)	
	Before Exposure	After Exposure	Before Exposure	After Exposure
As-received	55	3	111	101
Oxygen Contaminated	115	8	123	102
Oxygen Contaminated	220	9	135	101
Oxygen Contaminated	270	7	142	99
Oxygen Contaminated	520	10	171	100

(a) Vacuum Fusion Analysis.

(b) Average of nine equally spaced impressions across the specimen thickness (0.040-inch).
No gradients were indicated. 50 Kg Load 50X Objective.

2. Effects of Welding on the Hardness and Oxygen Concentration of Oxygen Contaminated Tantalum

a. Before NaK Exposure

As described previously in the metallographic examination results, welding contaminated specimens significantly changed the morphology of the corrosion. Welding also changes the microhardness and chemistry of oxygen contaminated tantalum specimens. Welding reduced the oxygen concentration of the weld nugget of oxygen contaminated specimens as shown in the chemical analysis data presented in Table V. Although the data is limited, the results indicated a greater purification effect occurs by welding in pure helium than in helium containing 250 ppm air. It was also noted that reductions in oxygen concentration as a result of welding were smaller in the heat affected zones than in the weld nuggets.

b. After Exposure to NaK

Reductions in oxygen concentration in the weld and heat affected zone areas after NaK exposure were less than previously described for unwelded specimens, and the reductions were greater in the weld than in the heat affected zone. The oxygen concentrations after NaK exposure were higher in specimens initially containing 520 ppm oxygen than in similar specimens containing 270 ppm.

3. Effects of NaK Temperature and Exposure Time on the Oxygen Concentration and Microhardness of Oxygen Contaminated Tantalum

The few tantalum specimens exposed to NaK at 1200°F for 100 hours were used for the metallographic examination which is described in Section C3 of this report. As a result, microhardness measurements were employed to describe the oxygen concentration in these specimens, knowing the relationship between hardness and oxygen concentration as shown previously in Figure 15. These microhardness results were compared with similar results for specimens exposed at 1350°F for 1000 hours. The hardness profiles in the heat affected zones of welded tantalum specimens containing 520 ppm oxygen in the as-welded condition and after exposure to NaK is shown in Figure 16. The hardness profiles for specimens exposed at 1200°F for 100 hours and for those exposed at 1350°F for 1000 hours are indicative of oxygen diffusion within the specimens and subsequent

TABLE V. OXYGEN CONCENTRATION OF TANTALUM
SPECIMENS EXPOSED
TO NaK FOR 1000 HOURS AT 1350°F

Specimen	Oxygen Concentration, ppm (a)		
	Before Exposure	After Exposure	
As-received	55	3	
Oxygen Contaminated	115	8	
Oxygen Contaminated	220	9	
Oxygen Contaminated	270	7	
Oxygen Contaminated	520	10	
Ta + 520 ppm Oxygen Welded in Pure Helium	Weld Nugget Heat Affected Zone	456 495	48 67
Ta + 520 ppm Oxygen Welded in Helium + 250 ppm Air	Weld Nugget Heat Affected Zone	500 525	60 70
Ta + 270 ppm Oxygen Welded in Pure Helium	Weld Nugget Heat Affected Zone	250 260	24 35
Ta + 270 ppm Oxygen Welded in Helium + 250 ppm Air	Weld Nugget Heat Affected Zone	- -	22 24

(a) Vacuum Fusion duplicate analysis averaged.

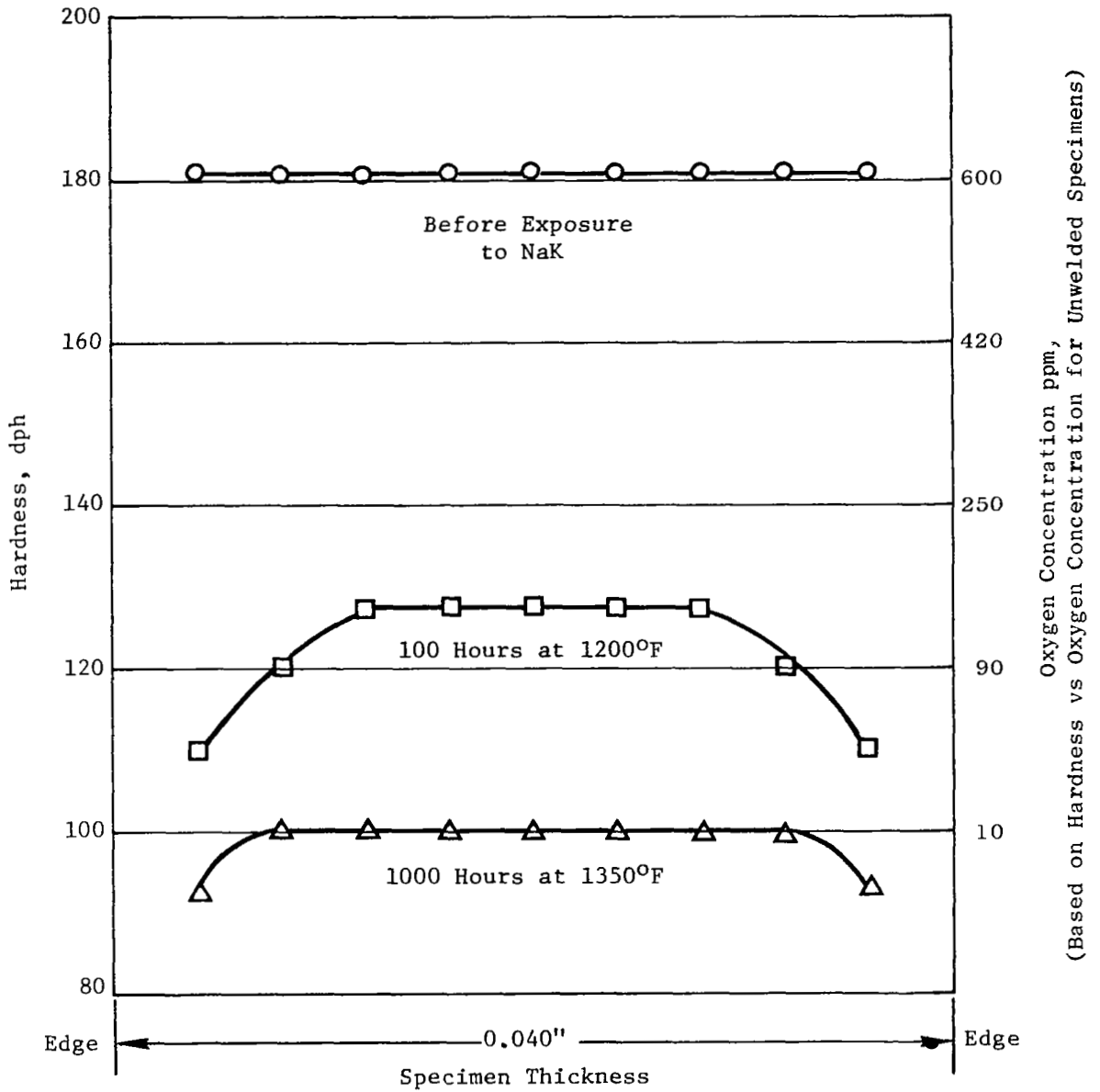

Figure 16. Microhardness Profiles in the Heat Affected Zones of Welded Tantalum Specimens Containing 520 ppm Oxygen Before and After Exposure to NaK.

dissolution occurring at the tantalum-NaK interface and are also consistent with the observed differences in the extent of corrosion in those specimens. During NaK exposure of tantalum specimens containing over 270 ppm oxygen two processes occur simultaneously, namely, (1) oxygen dissolution and (2) corrosion along grain boundaries and crystallographic planes. Oxygen diffusion in the tantalum and concomitant oxygen dissolution are strongly temperature dependent. At high temperature, oxygen diffusion and dissolution can occur at a fast enough rate to reduce the oxygen concentration in the tantalum region ahead of the advancing corrosion to a value below that necessary for corrosion to occur, thereby preventing corrosion from progressing very deeply into the specimens. This effect was observed in the welded tantalum specimens containing 520 ppm oxygen exposed at 1350^oF for 1000 hours where the depth of attack in the heat affected zone was limited to 8 mils. In similar specimens exposed at 1200^oF for 100 hours, the oxygen diffusion and dissolution rate was not sufficiently high to lower the oxygen concentration below that necessary for corrosion to occur and complete penetration of the 0.040 inch thick specimens was observed.

IX. OBSERVATIONS

The oxygen contaminated tantalum specimens exposed to NaK in this study were prepared in a manner to produce homogeneous oxygen concentrations and thereby facilitate the determination of the oxygen concentration - corrosion relationships. However, in the boiler, the ID side of the 0.040 inch wall tantalum tube is exposed to possible oxygen contamination whereas the OD is in contact with static NaK. Corrosion would occur if the tantalum at the OD surface in contact with NaK reaches an oxygen concentration of 270 ppm or greater. However, if the oxygen concentration in the tantalum is below this level at the start, a 270 ppm oxygen concentration can only be reached by diffusion of oxygen from the ID to the OD. Results of the Ta-NaK capsule tests have shown oxygen dissolution will occur at the tantalum-NaK surface without corrosion if the concentration is below 270 ppm. Calculations indicate the diffusion rate of oxygen in tantalum at 1350°F is low and the dissolution of oxygen at the tantalum NaK interface may maintain the oxygen concentration below the threshold level for corrosion.

X. REFERENCES

1. Private communication from J.H. DeVan, Oak Ridge National Laboratory.
2. Scheuermann, C.M. and Barrett, C.A., "Compatibility of Columbium and Tantalum Tubing Alloys with Refluxing Potassium," NASA TN D-3429, May 1966.
3. Romano, A.J., et al, "A Summary of the High Temperature Alkali Metal Corrosion Program at Brookhaven National Laboratory," AEC-NASA Liquid Metals Information Meeting, CONF-650411, April 1965, p. 233.
4. Stang, J.H., et al, "Compatibility of Liquid and Vapor Alkali Metals with Construction Materials," DMIC Report 227, April 15, 1966, p. 63.
5. Lyon, T.F., "Purification and Analysis of Helium for the Welding Chamber," Topical Report Number 1, NAS 3-2547, NASA-CR-54168, July 1965.
6. Hoffman, E.E. and DiStefano, J.R., "Relation Between Oxygen Distribution and Corrosion in Some Refractory Metal-Lithium Systems," Corrosion of Reactor Materials, Vol. II, International Atomic Energy Agency, Vienna, 1962.
7. DiStefano, J.R., "Corrosion of Refractory Metals by Lithium," USAEC Report ORNL-3551, March 1964.
8. Litman A.P. "The Effect of Oxygen on the Corrosion of Niobium by Liquid Potassium," USAEC Report ORNL-3751, July 1965.