

General Disclaimer

One or more of the Following Statements may affect this Document

- This document has been reproduced from the best copy furnished by the organizational source. It is being released in the interest of making available as much information as possible.
- This document may contain data, which exceeds the sheet parameters. It was furnished in this condition by the organizational source and is the best copy available.
- This document may contain tone-on-tone or color graphs, charts and/or pictures, which have been reproduced in black and white.
- This document is paginated as submitted by the original source.
- Portions of this document are not fully legible due to the historical nature of some of the material. However, it is the best reproduction available from the original submission.

Apollo Lunar Surface Experiments Package

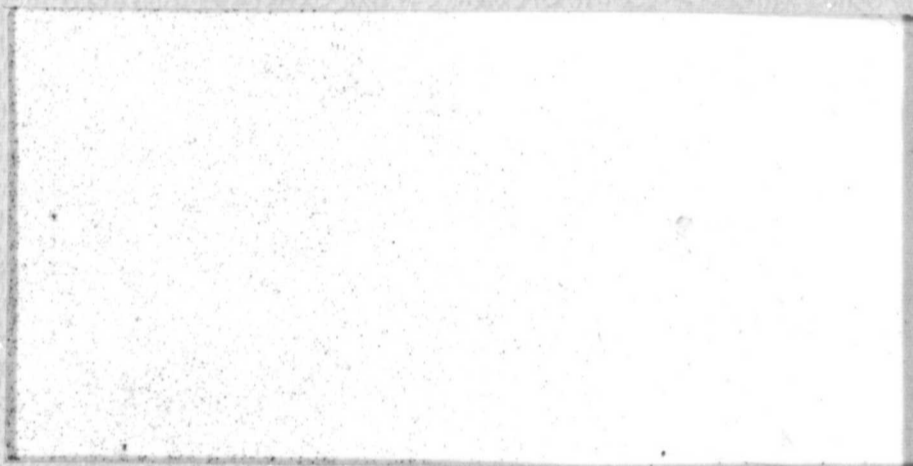

FACILITY FORM 602

N71 31607 (ACCESSION NUMBER)	(THRU)
112 (PAGES)	(CODE)
CR-115709 (NASA CR OR TMX OR AD NUMBER)	30 (CATEGORY)

Prepared for

NASA/Manned Spacecraft Center

by



**Aerospace
Systems Division**

CR-115109

DESIGN CERTIFICATION REVIEW

(Supplement for ALSEP Array A-2)

June 1971

BSR-2454A

Contract NAS 9-5829

**ALSEP SCIENTIFIC EXPERIMENTS
DESIGN REPORT**

VOLUME 7D

OF THE

DESIGN CERTIFICATION REVIEW

(SUPPLEMENT FOR ALSEP ARRAY A2)

June 1971

BSR 2454A

NAS 9-5829



**Aerospace
Systems Division**

SECTION 1

INTRODUCTION

This volume supplements BSR 2454, ALSEP Scientific Experiments Design Report. Its purpose is to define the design and performance differences between ALSEP Array A2 and ALSEP Array A (Flight System 1) which was described in BSR 2454. This document follows the prescribed format and outline of PA-D-67-15 of 19 February 1968.

SECTION 2

DESIGN CONCEPTS AND CRITERIA

2.1 BACKGROUND AND OBJECTIVES

The broad goals of lunar exploration have been stated as follows: (1) obtain information from the moon to determine its environment, composition, and gross body properties, (2) utilize the unique characteristics of the moon to establish observatories and laboratories for long-term scientific investigations, and (3) determine if lunar resources could be used for extended lunar operations, future interplanetary exploration, and terrestrial purposes. The knowledge gained from these goals will allow not only an understanding of the moon, but will also provide insight into the history and evolutionary sequence of events in the formation of our solar system. In essence, these broad goals are the object of all planetary and subplanetary investigations, that is, to provide a sound basis for comparative study. The moon's proximity to the earth, its peculiar environment which provides unobstructed observation of our solar system, and the geological process of its evolution make it the logical first step for manned exploration of the solar system.

The National Academy of Sciences Space Science Board meeting at Woods Hole, Massachusetts in the summer of 1965 undertook a study of certain principal areas of space research, including lunar exploration. At this meeting, 15 major questions associated with exploration of the moon were established. These questions pertained to: (1) the structure and process of the lunar interior, (2) the composition and structure of the surface of the moon and the processes modifying its surface, and (3) the history or evolutionary sequence of events by which the moon has arrived at its present configuration. These questions are listed below and provide a detailed elucidation of the initial goal:

1. What is the internal structure of the moon?
2. What is the geometric shape of the moon?

3. What is the present internal energy regime of the moon?
4. What is the composition of the lunar surface?
5. What principal processes are responsible for the present structure of the lunar surface?
6. What is the present tectonic pattern and distribution of tectonic activity on the moon?
7. What are the dominant processes of erosion, transport, and deposition of material on the lunar surface?
8. What volatile substances are present on or near the lunar surface?
9. Are there organic or proto-organic molecules on the moon?
10. What is the age of the moon and the age range of stratigraphic units on the lunar surface?
11. What is the history of dynamic interaction between the earth and the moon?
12. What is the thermal, the tectonic, and possible volcanic history of the moon?
13. What has been the rate of solid objects striking the moon and how has that flux varied with time?
14. What is the history of cosmic and solar radiation flux acting on the moon?
15. What magnetic fields are retained in rocks on the lunar surface?

A number of scientific areas will contribute the knowledge and operational techniques necessary for lunar exploration. Aside from the obvious contributions of the geoscience areas (geodesy, geology, geochemistry, and geophysics), other disciplinary areas contributing include biology, particles and fields, lunar atmospheres, and astronomy. Following the National Academy of Sciences meeting, the National Aeronautics

and Space Administration conducted a Lunar Exploration and Science Conference at Falmouth, Massachusetts to consider the specific approaches to be taken in each of the disciplinary areas. The groups considered various exploration techniques and the investigations and experiments to be conducted.

From the definition of scientific problems, experiments to be conducted, and the specific lunar locations to be visited, consideration turned to specific lunar surface exploration system concepts, i. e., the particular combination of scientific experiment hardware by which the scientific data will be obtained in lunar missions.

The Apollo Program provides the opportunity for advanced scientific studies of the moon, and as part of the Apollo Program for manned lunar landing and exploration, a package of scientific instruments, known as the Apollo Lunar Surface Experiments Package (ALSEP), has been designed and built to be transported to the moon aboard the Lunar Module (LM) and emplaced by the astronaut.

2.2 EXPERIMENT SELECTION CRITERIA

The experiment complement selected for Array A2 includes the Heat Flow Experiment as well as the four experiments allocated to ALSEP Flight 1, namely, Passive Seismic, Magnetometer, Solar Wind, and Suprathermal Ion Detector.

The following paragraphs present a description of the Heat Flow Experiment. The descriptions of the remaining four experiments are contained in the original ALSEP Scientific Experiments Design Report BSR 2454 (a complete list of the experiments selected for Array A2 and their Principal Investigator is presented in Figure 2-1).

2.2.1 Heat Flow Experiment (HFE) NASA No. 5037

The Heat Flow instrument is designed to measure the net outward flux of heat from the moon's interior. This will provide information on:

- (a) Profile of temperature vs. depth.
- (b) Comparison of moon's interior with earth's mantle.
- (c) Value of thermal parameters in moon's crust.
- (d) Thermal history of the moon.

The heat flow measurements will be made by thermal sensors placed in holes drilled in the lunar surface by the astronauts. These sensors not only measure temperature differentials at various levels in the holes, but also, in association with active heaters incorporated in the same probe with the sensors, provide information from which the thermal conductivity of the lunar material can be deduced.

The Heat Flow instrument is pictured in Figure 2-2. The instrument consists of two probes, connected by electrical cables to an electronics package which, in turn, is electrically connected to the ALSEP Central Station. Each probe contains platinum resistance bridge thermometers, heaters and reference thermocouples. The electronics package contains circuitry for control of heater excitation, timing and sequencing of measurements, and formatting of data.

Principal investigator for the Heat Flow Experiment is Dr. Marcus G. Langseth of Columbia University. Co-investigators are Dr. Sidney Clarke of Yale and Dr. M. Eugene Simmons of MIT.

<u>NASA No.</u>	<u>EXPERIMENT</u>	<u>PRINCIPAL INVESTIGATOR</u>
S031	Passive Seismic	Dr. G. V. Latham, Columbia University
S034	Magnetometer	Dr. P. Dyal, Ames Research Center
S035	Solar Wind	Dr. C. W. Snyder, JPL
S036	Suprathermal Ion Detector	Dr. J. W. Freeman, Rice University
S058	Cold Cathode Gauge*	Dr. F. S. Johnson, Southwest Center For Advanced Studies
S037	Heat Flow	Dr. M. Langseth, Columbia University

*Included in Suprathermal Ion

Figure 2-1. ALSEP Experiments

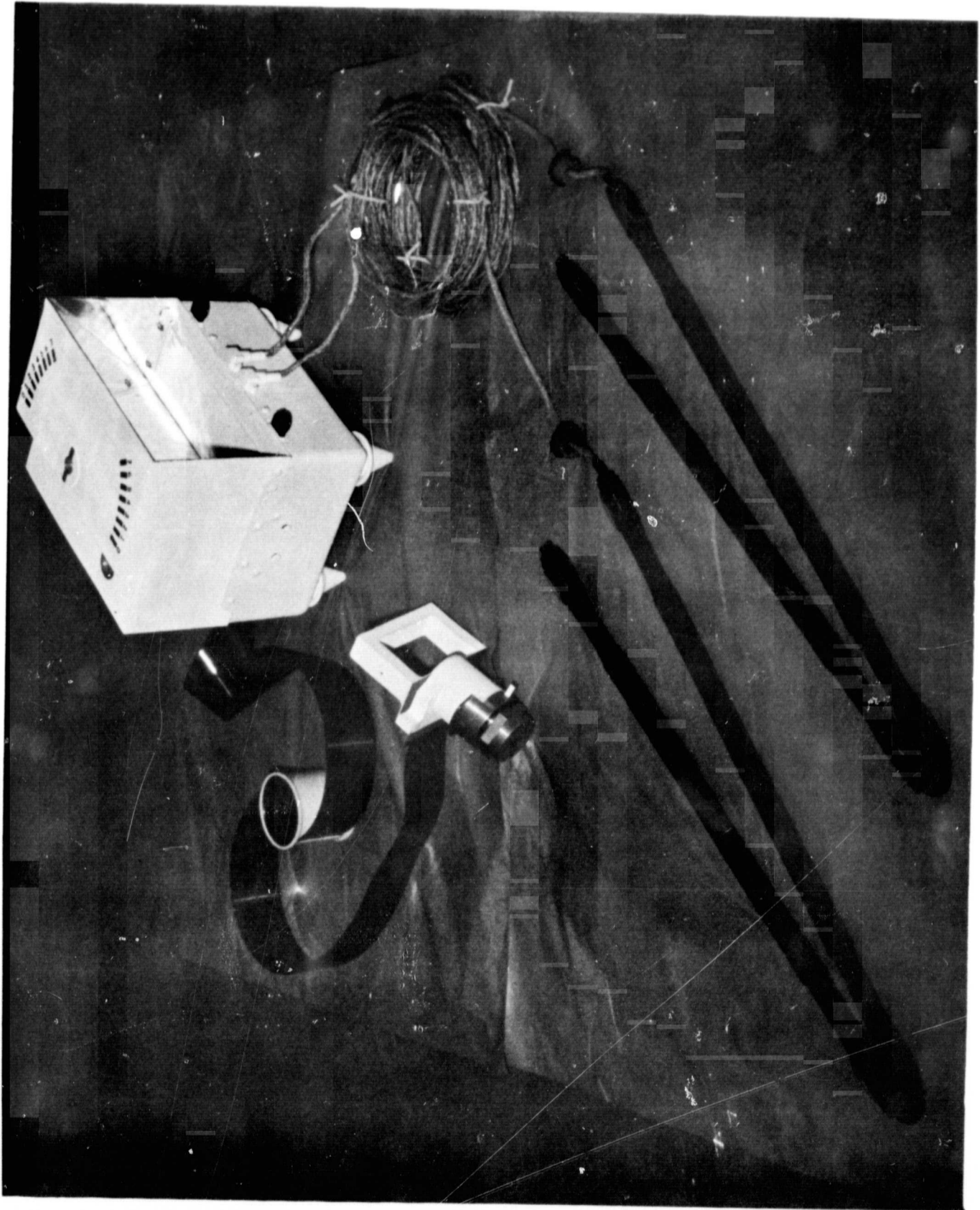

Figure 2-2 Heat Flow Experiment

2.3 GENERAL SYSTEM REQUIREMENTS AND CONSTRAINTS

The system requirements and constraints for Array A2 are identical to those for Flight 1 with the following exceptions: (2) the addition of HFE to the experiment complement requires additional stowage space in the LM for the Apollo Lunar Surface Drill (ALSD). (b) the lunar deployment sequence must allow for the drilling of two holes in the moon's surface for the HFE probes, in addition to the routine deployment of the HFE electronics package and associated cabling.

2.4 GENERAL INTERFACE REQUIREMENTS

Most of the interface requirements applicable to Array A2 are identical to those of ALSEP Flight 1. The differences are described below.

2.4.1 Vehicle Interfaces

Vehicle constraints include mass properties, structure and environment.

2.4.1.1 Mass Properties

Array A2 has been assigned stowage space in two compartments of the SEQ bay in Quadrant II of LM, and at one location external to the LM (for the fuel cask as in Flight 1).

A total allowance of 286 pounds of Earth weight was originally allocated to Array A2 per CCP 262-3. Of this total, no more than 266 pounds total may be stowed in the SEQ bay, with individual limits of 155 pounds for Compartment I or Compartment II.

As a result of CCP 262, CCP 229 and CCP 285 for the addition of HFE equipment and modifications to SIDE and PSE the total weight for ALSEP A2 was increased to 293.35 lbs.

Desired centers of gravity for the SEQ bay compartments are defined in ALSEP coordinates as follows:

	<u>Compartment I</u>	<u>Compartment II</u>
X	7.985 to 10.985	9.608
Y	-12.445	13.185
Z	12.045	11.966

The maximum c.g. envelope for each compartment is a sphere, centered at the above coordinates, whose radius is 5" for a 105-pound (or less) package, with the radius decreasing linearly to 3.75" for packages weighing 115 pounds or more.

2.4.1.2 Structural Interfaces

Structural interface definitions for the fuel cask and SEQ bay components are identical to those of ALSEP Flight 1. Installation and tie-down provisions for the Quad I pallet are defined in Grumman drawing LID 360-22834.

SECTION 3

SYSTEM DESCRIPTION

3.1 The ALSEP system differences between Array A and A2 are summarized in this section. The major changes consist of the addition of the Heat Flow Experiment to Subpackage 2, the replacement of the timer, multiplexer and transmitters, and the incorporation of certain structural/thermal changes.

3.2 DATA SUBSYSTEM (DSS)

With the exception of the Central Station timer, analog multiplexer and transmitters, the DSS components of Array A2 are essentially the same as those of Flight System 1. Figure 3-1 shows the general arrangement of the Central Station components.

3.2.1 Central Station Resettable Solid State Timer (RSST)

The Central Station timer provides output pulses which are used by the command decoder to initiate specific functions within ALSEP experiments and within the DSS when the uplink is unavailable for any reason. A listing of these delayed commands, and their time of occurrence, is shown in Figure 3-2. A photograph of the timer unit is shown as Figure 3-3.

The timer circuitry counts the pulses of its own electronic oscillator and provides repetitive output signals to the command decoder at intervals of 1 minute and at intervals of 18 hours. It also provides telemetry outputs, to the analog multiplexer, indicating the status of its 18-hour and two 1 1/2 month registers.

The timer operates off the + 12-volt output of the PCU and begins its timing function when the PCU is started by the deploying astronaut.

CENTRAL STATION COMPONENTS

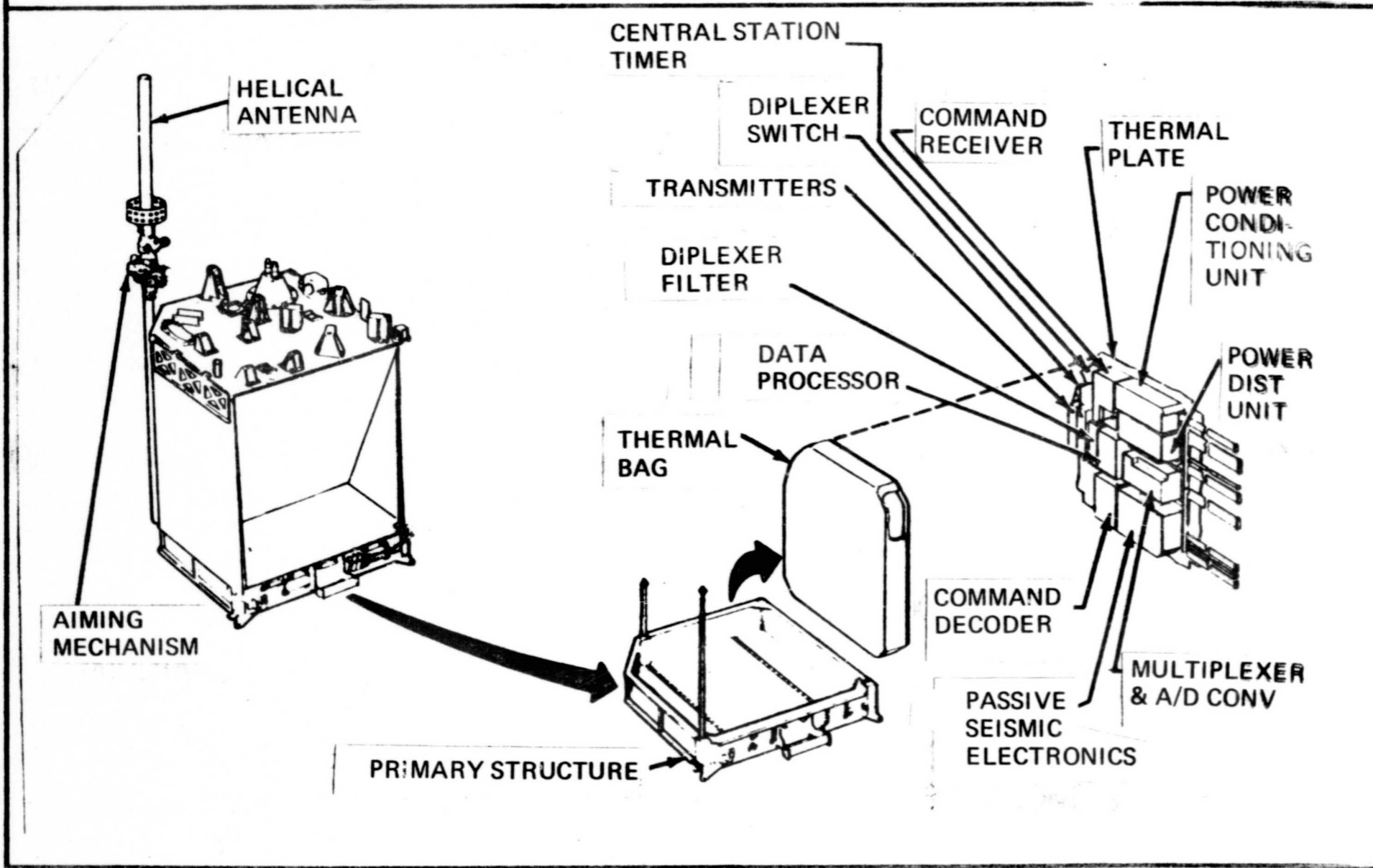

Figure 3-1



DELAYED COMMAND
 FUNCTIONS

COMMAND (OCTAL)	FUNCTION	TIME OF EXECUTION
105	SET CCIG SEAL BREAK	144 HR + 2 MIN
73	ARM PSE UNCAGE PSE	144 HR + 2 MIN
110	EXECUTE CCIG SEAL BREAK	144 HR + 3 MIN
122	REMOVE SWE DUST COVER	144 HR + 4 MIN
107	SET SIDE REMOVE DUST COVER	144 HR + 4 MIN
110	EXECUTE SIDE REMOVE DUST COVER	144 HR + 5 MIN
131	MAGNETOMETER FLIP CALIBRATE	162 HR + 1 MIN, THEN EVERY 18 HRS
73	FIRE UNCAGE PSE	162 HR + 2 MIN
	RESET RECEIVER CIRCUIT BREAKER	EVERY 18 HRS
66	CALIBRATE SP PSE	EVERY 18 HRS AFTER 144

Figure 3-2

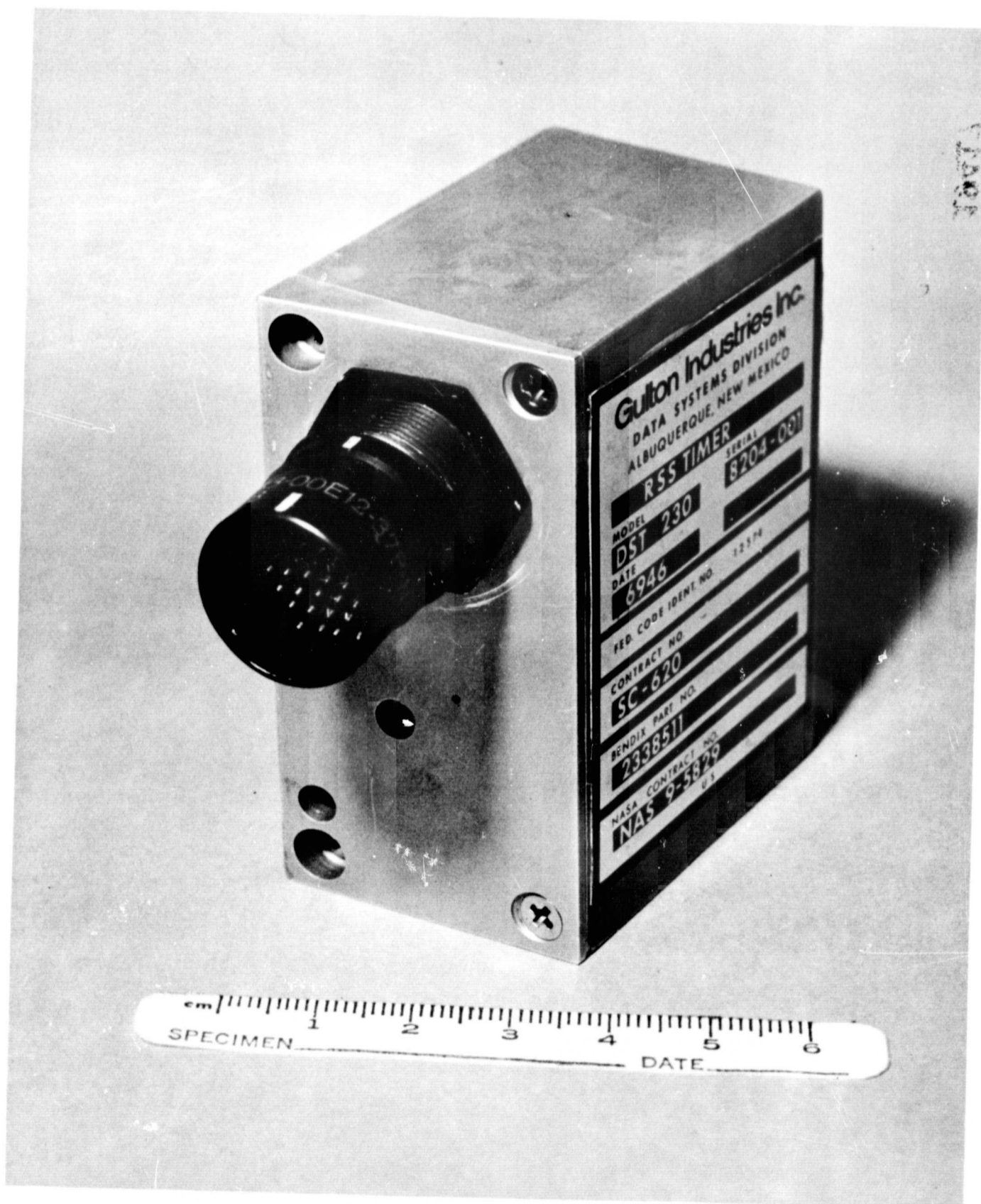

Figure 3-3 RSS Timer

The timer registers are resettable by transmission of octal command 150 from Earth. This command clears all counting registers. Command 150 must be transmitted periodically (e. g., at 1.5-month intervals) as a routine operating procedure. If the timer has not been reset for a period of approximately three months, (97 days \pm 6 days), a latching relay closure output signal is transmitted by the timer to the PDU, turning OFF the transmitter.

Redundant registers and relay drivers are series combined so that a single point failure will not cause premature relay closure (early time-out). As an additional precaution against early time-out, the timer's output relay closure has been capacitively coupled to the transmitter turn-off relay. This makes the output closure a momentary signal and permits a subsequent turn-ON of the transmitter at the judgment of MSC operating personnel (with the knowledge that the system's automatic turn-OFF feature has been expended).

In the event of power dropout, the timer will retain the count stored in its registers for a period of time up to 5 minutes. If power dropout persists for a longer period, the RSST registers are reset when power is restored.

3.2.2 Analog Multiplexer

The multiplexer for Array A2 has been redesigned to provide full redundancy of the analog data processor. (ALSEP Flight System 1 had redundant A/D converters but a single 90-channel multiplexer.)

A block diagram of the A2 analog processor is shown in Figure 3-4. Each of the two redundant analog processors is associated with one of the Digital Data Processors (X or Y), and its DC power is switched in the PDU with that of the companion digital unit.

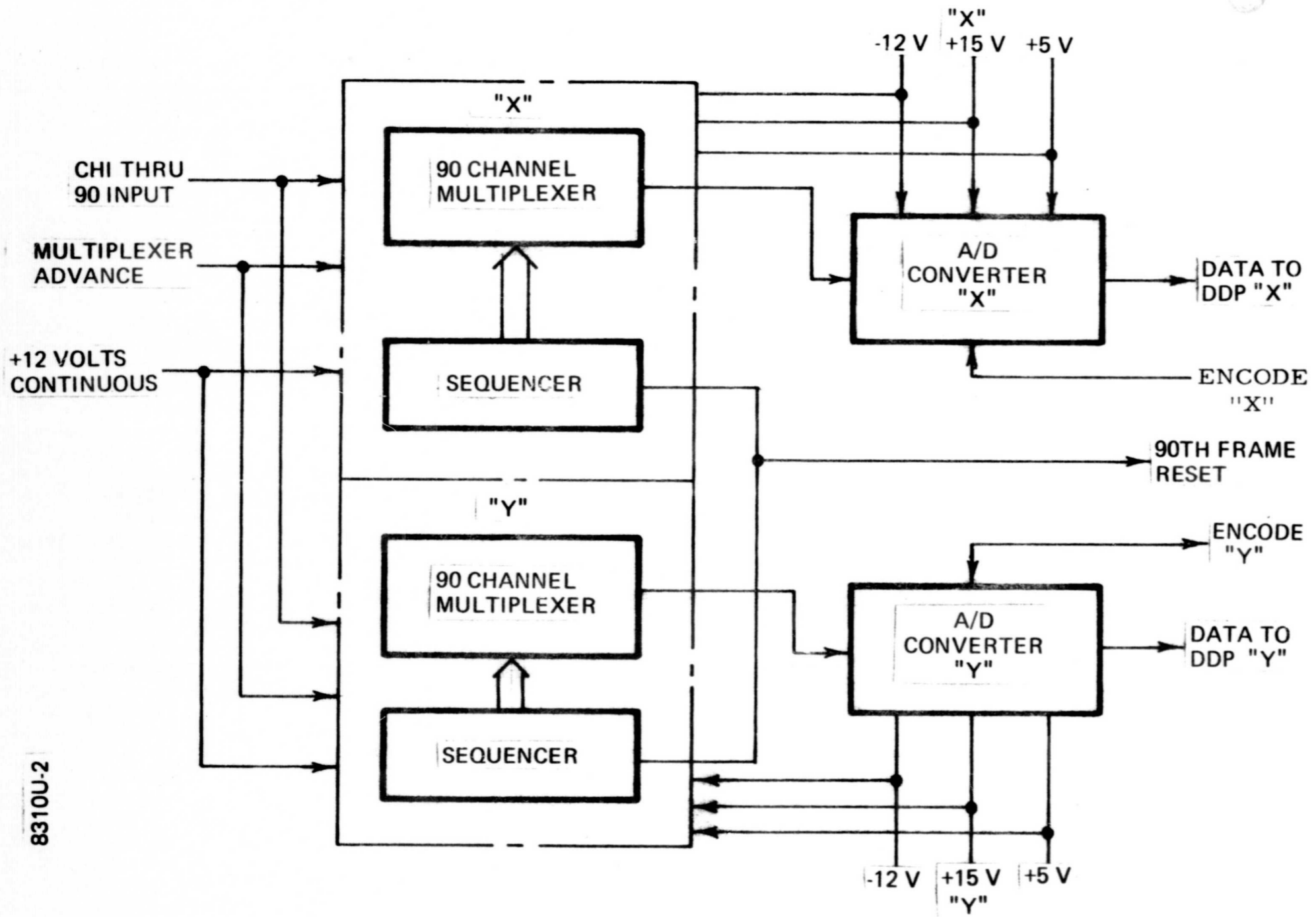

8310U-2

Figure 3-4 Block Diagram 90 Channel Multiplexer (Redundant)

Multiplexer advance pulse lines are paralleled in from the digital data processors, but only the powered multiplexer advances. A/D encode pulses are received only from the powered digital data processor. If trouble is encountered anywhere in the analog processor, the entire data processor (digital and analog) can thus be switched by ground command, octal 34 (X) or 35 (Y). (The preset position is "X".)

A photograph of the A2 Multiplexer and ADC package is shown in Figure 3-5.

3.2.3 Transmitter

The Bendix transmitter, shown in Figure 3-6, replaced the Philco transmitter used for flight 1. The Bendix transmitter generates an S-band frequency carrier which is biphase-modulated by the coded binary bit stream from the data processor. The transmitter operates on Channel No. 5 (2278.0 MHz).

Two identical transmitters are used in the data subsystem to provide standby redundant operation. Either transmitter can be selected to transmit downlink data. To meet the downlink probability of error requirement (10^{-4} or less), the transmitter output power is one watt, minimum. Other significant features of the transmitter are summarized in Figure 3-7.

Figure 3-8 shows a block diagram of the transmitter circuit. Descriptive titles of the various modules define their operational functions.

Monitor circuit outputs provide analog signals to the data processor indicating the status of current on the +29 v line, the level of RF power output, and the temperatures at the oscillator crystal and power amplifier heat sinks.

3.3 Structure/Thermal Subsystem

The structure/thermal subsystem provides the structural integrity and passive thermal protection required by the ALSEP experiments and support subsystems to withstand the various environments encountered in storage, testing, loading on the LM, space flight, and lunar deployment. During operation on the moon, the structure/thermal subsystem will



Figure 3-5 A-2 Multiplexer

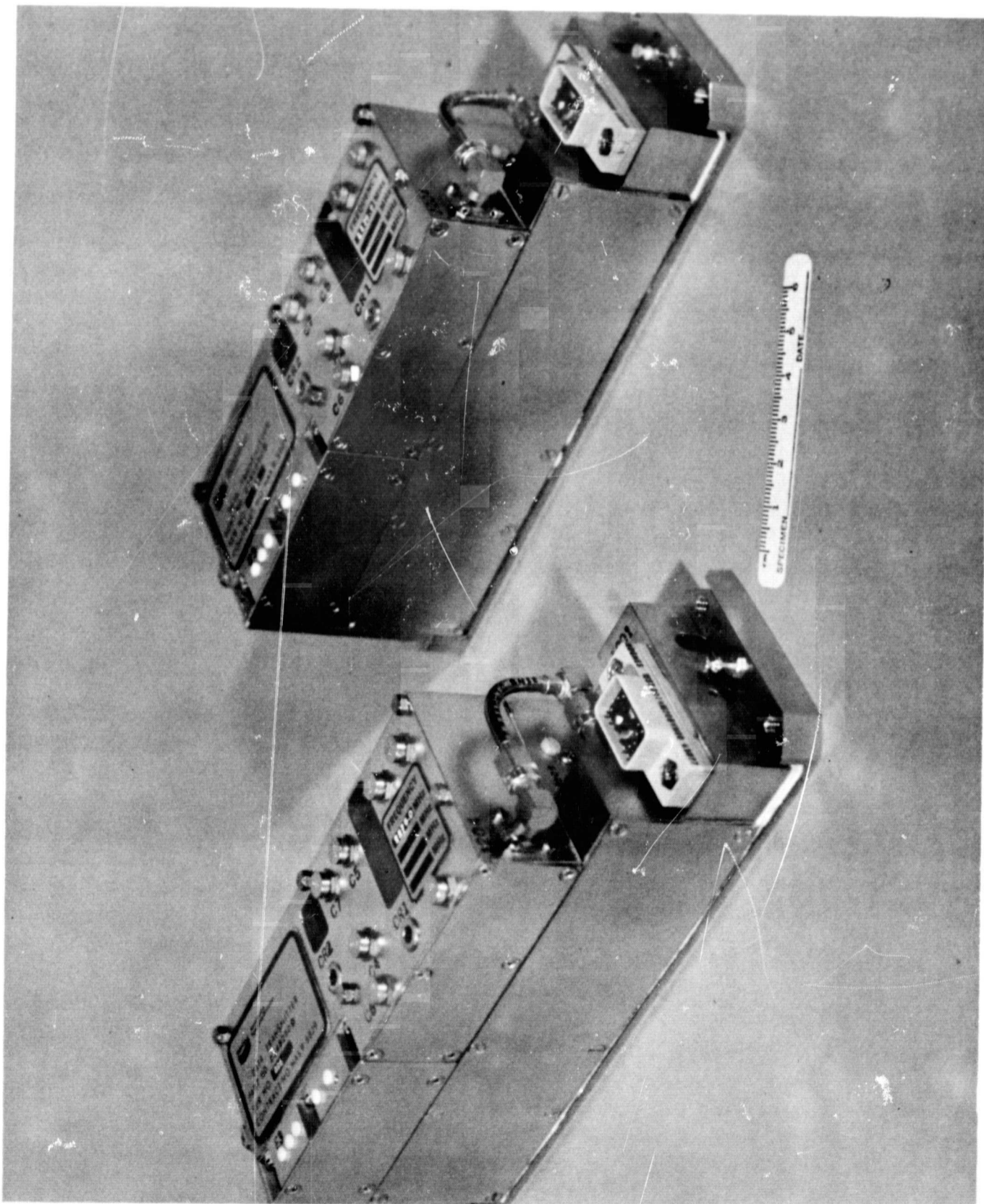

Figure 3-6 ALSEP BxA Transmitter



**Aerospace
Systems Division**



TRANSMITTER DESIGN FEATURES

PROVIDES A MINIMUM OF ONE WATT INTO A 50-OHM LOAD WITH A MAXIMUM VSWR OF 1.3:1.

PROPER CRYSTAL IS INSTALLED DURING MANUFACTURE FOR OPERATION ON 2278.0 MHz (CHANNEL #5).

FREQUENCY STABILITY IS 0.0025%/YEAR.

TWO IDENTICAL COMPONENTS, TRANSMITTER A AND TRANSMITTER B, ARE PROVIDED, WITH ONE IN STANDBY.

EITHER A OR B MAY BE SELECTED BY COMMAND FROM THE MSFN.

IF ONE IS SWITCHED OFF BY CIRCUIT BREAKER ACTION, THE OTHER IS AUTOMATICALLY SWITCHED ON.

IF COMMANDED OFF, A RESISTOR (HEATER) IS AUTOMATICALLY SWITCHED ON TO PROVIDE FOR CENTRAL STATION THERMAL STABILITY.

Figure 3-7

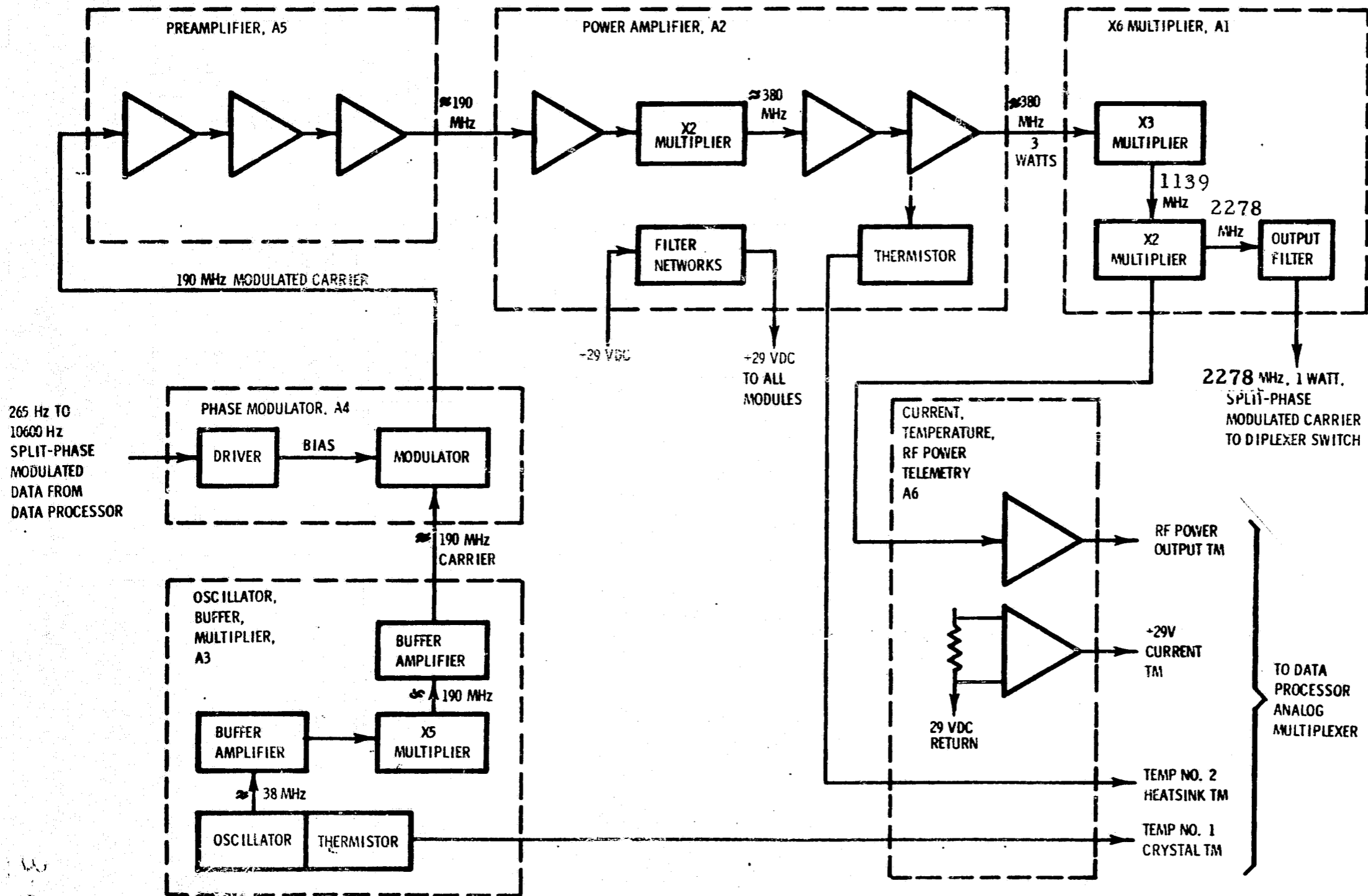

Figure 3-8 Transmitter Functional Block Diagram

3-11

3-11

continue to provide structural support and thermal protection to the DSS in the Central Station and to the EPS, as well as to the PSE electronics package housed in the Central Station.

The A2 structure/thermal subsystem differs from that of ALSEP Flight 1. Relatively minor changes have been accomplished on Subpackages 1 and 2.

3.3.1 Subpackage 1 Structure/Thermal Features

The following changes have been made on subpackage #1:

1. Addition of back thermal curtain to permit off-equator deployment; a bracket has been added for stowing the curtain.
2. Addition of two gnomons and associated compass dial on the sunshield for Central Station orientation in off-equatorial locations, both north and south of the lunar equator.

3.3.2 Subpackage 2 Structure/Thermal Features

The major Subpackage 2 hardware change initiated to accommodate the new deployment constraints, was a modification of the antenna aiming mechanism, keying it to either of two positions on the antenna mount, 180° apart. This simplifies antenna pointing by permitting a rough azimuth alignment (within 180°) in the assembly procedure.

The heat flow experiment, formerly allotted to S/P 3, has been added to Subpackage 2. S/P 3 has been omitted. The ALSD and ALHT are no longer part of ALSEP and are stored elsewhere on LEM.

3.4 EXPERIMENT SUBSYSTEMS

To accomplish the scientific objectives of ALSEP, five experiment subsystems have been assigned to Array A2. These experiment subsystems include the four carried on ALSEP Array A and described in BSR-2454, plus the Heat Flow Experiment.

3.4.1 HFE Physical Description

The major components of the HFE are shown in Figure 2-2. The probes consist of epoxy-fiberglass tubular structures which support and house temperature sensors, heaters, and the associated electrical wiring. Each probe has two sections, each 55 cm long, spaced 2 cm apart and mechanically connected by a flexible spring. The flexible spring allows the probe assembly to be bent into a U-shape to facilitate packing, stowage, and carry.

There is a gradient temperature sensor surrounded by a heater coil at each end of each probe section. Each of these two gradient sensors consists of two resistance elements. The four resistance elements are connected in an electrical bridge circuit. Ring sensors are located 10 cm from each end of each probe section. Each of these two ring sensors has two resistance elements. The four resistance elements are connected into an electrical bridge circuit. Four thermocouples are located in the cable of each probe.

The heat flow electronics package contains six printed circuit boards which mount the functional electronic circuits of the experiment. An external cable reel houses the HFE/Central-Station cable and facilitates deployment. A sunshield thermally protects the electronics package from externally generated heat. Two reflectors built into the open ends of this sunshield aid in the radiation of internally generated heat that otherwise might be entrapped under the sunshield. The electronics package is thermally protected by multilayer insulation and thermal control paint. The leading particulars of the HFE are listed below:

HFE Leading Particulars

Characteristic	Value
Size of probes (both packaged for flight) in inches	25.5 x 4.5 x 3.52
Size of electronics unit in inches	11.82 x 10 x 9
Weight of probes (both packaged for flight) in pounds	3.67
Weight of electronics unit in pounds	5.8
Power Requirements	
Mode 1 and 2	5.6 watts (day) 10.2 watts (night)
Mode 3	6.9 watts

3.4.2 HFE Functional Description

HFE is responsive to 10 different Earth commands as follows:

HFE Command List

Command Number	ALSEP Octal Command	Nomenclature
CH-1	135	Gradient mode select
CH-2	136	Ring-source conductivity mode select
CH-3	140	Heat-pulse conductivity mode select
CH-4	141	Full sequence select
CH-5	142	Probe number 1 sequence select
CH-6	143	Probe number 2 sequence select
CH-7	144	Subsequence select
CH-8	145	Subsequence select
CH-9	146	Subsequence select
CH-10	152	Heater advance

*These three commands are used to select measurement subsequences as follows:

144 High sensitivity gradient

144, 145 Low sensitivity gradient

144, 146 Probe ambient temperatures

145, 146 Thermocouple

These Earth commands are received through the data subsystem, and initiate desired modes of HFE operation.

The measurement sequencing function sets up the pattern for the operation of the temperature measuring function which senses in one of the three operational modes and reports analog temperature data back to the data handling function. The data handling function converts the analog data to digital format and sends it to the data subsystem for downlink transmission to Earth. When required, the probe heater excitation function provides controlled power to the heaters in the probes.

The thermal control function maintains the proper operating temperature for the HFE electronics package. The power supply converts the 29-volt prime power to operating voltages required by all HFE circuitry.

3.4.3 Suprathermal Ion Detector Experiment (SIDE) Subsystem

The A2 instrument for the SIDE is essentially identical to that carried on Flight System 1. The only significant change is the addition of foldout legs on the broad sides of the case to permit tilting of the instrument for off-equator deployment. The A2 version of the instrument is shown in Figure 3-9. As in the Flight 1 configuration the SIDE subsystem includes the cold Cathode Ion Gage.

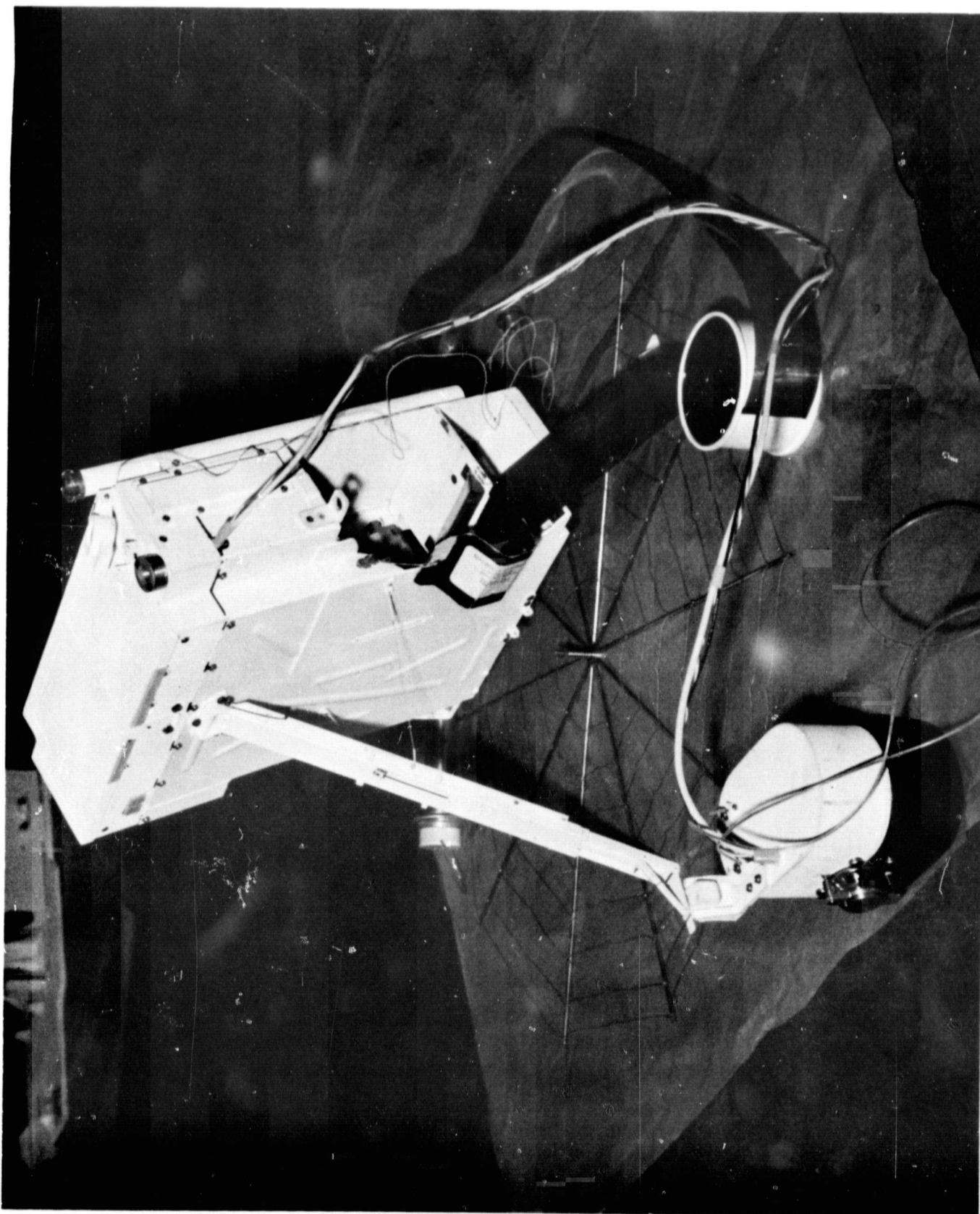

Figure 3-9 A-2 SIDE

3.5 SUPPORTING SUBSYSTEMS

The ALSEP supporting subsystems include the Dust, Thermal and Radiation Engineering Measurement Package, the special tools for lunar surface tasks, and auxiliary experiment hardware.

3.5.1 Dust, Thermal, and Radiation Engineering Measurements (DTREM) Package

The DTREM is used on Array A2 (replacing the Dust Detector of ALSEP Flight 1) to obtain data for assessment of dust accretion, radiation environment, package temperature, lunar surface brightness temperature, range of lunar surface thermal inertia parameter, and angular dependence of lunar surface infrared emission. The DTREM has two components: a sensor package and a printed circuit board.

3.5.1.1 Physical Description

The sensor package is mounted on the sunshield of Subpackage 1. Its overall dimensions are 2"H x 1.8" x 1.4", and its weight is about 0.3 pound. Active elements of the sensor package are three solar cells (each 1 x 2 cm) located on its top horizontal surface. Two of the cells are protected by a 0.006" cover glass and blue filter; the third cell is bare. Three temperature sensors are included in the package, one underneath the Kovar base mounting the three cells (adjacent to the center cell), and one each on the inside and outside of the vertical side wall of the package.

The sensor package is connected by a flat cable to the Central Station harness.

3.5.1.2 Functional Description

Dust accretion on the horizontal surface results in a reduction in the voltage output of all three cells. A differential reduction, resulting from the radiation environment, can also be detected by comparing the output of the bare cell against those of the filtered cells. One of the filtered cells also has been irradiated to alter its sensitivity to radiation. The three cells, thus, comprise a simple spectrometer to measure proton dosage in three discrete energy ranges.

The thermistor attached to the horizontal plate measures cell temperature. The thermistor mounted to the inside of the vertical wall measures the package temperature while the thermistor on the outside of the vertical wall provides a measure of lunar surface brightness temperature.

After conditioning as shown in Figure 3-10, the cell voltages, along with the temperature analogs, are routed to the DSS for telemetry in the ALSEP housekeeping word. Telemetry details are listed in Figure 3-11.

Two commands, CS-1 and CS-2, octal 27 and 31, respectively have been allocated to control power to the DTREM electronics, which runs off + 12 volts and - 12 volts. Power consumption in the ON mode is 0.24 watts and in the OFF mode (thermistors only) is 0.04 watts.

3.5.2 Special Tools

ALSEP special tools can be classified in three general categories - deployment tools, geological tools, and the Apollo-Lunar Surface Drill (ALSD).

3.5.2.1 Deployment Tools

The ALSEP deployment tools for Array A2 are the same as those carried on Flight System 1, namely: two universal handling tools (UHT), a cask dome removal tool (CDRT), and a fuel transfer tool (FTT).

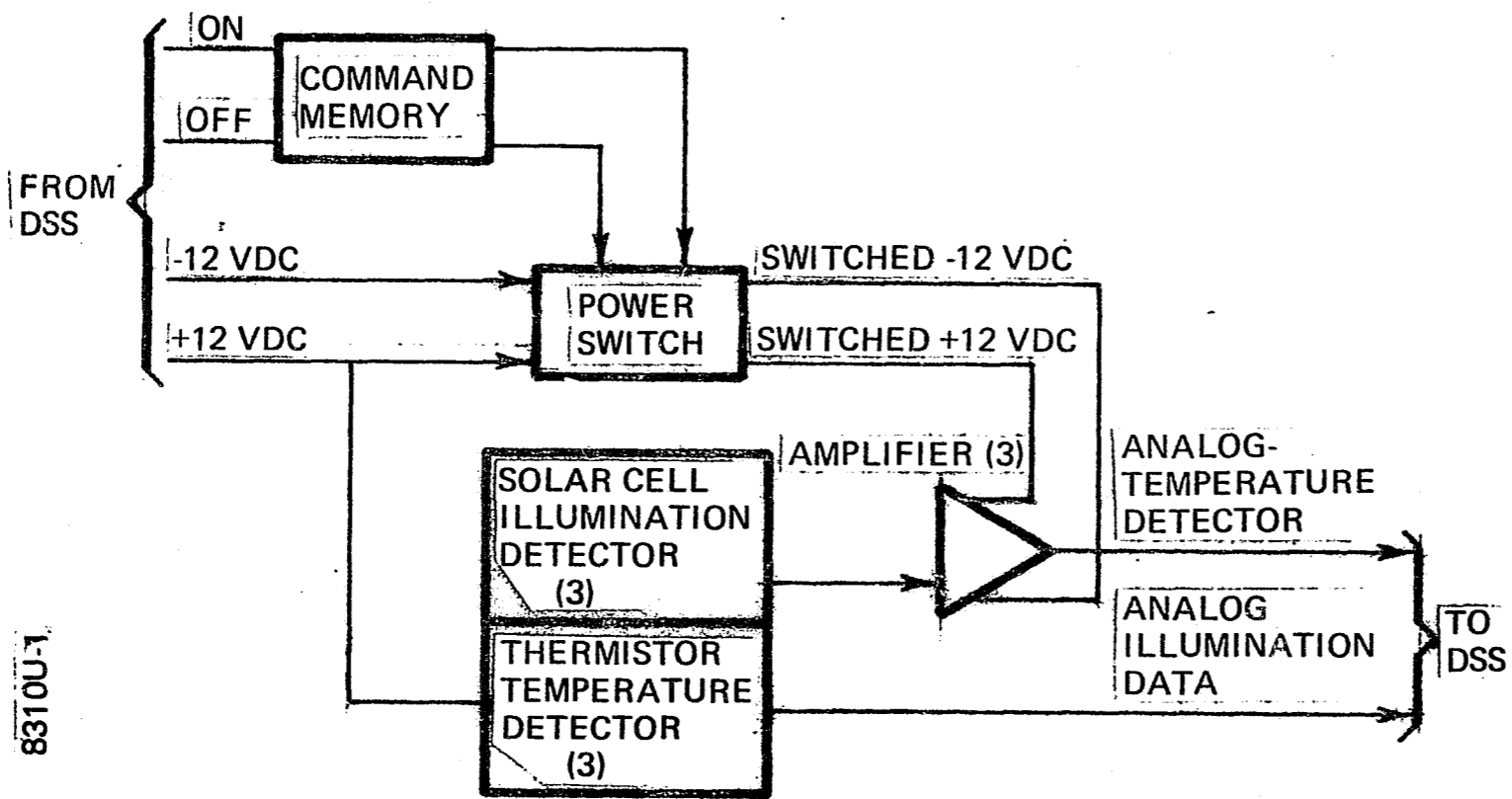

Figure 3-10 Dust, Temperature, and Radiation Engineering Measurements (DTREM) Block Diagram



Aerospace
Systems Division



DTREM TELEMETRY

<u>ID</u>	<u>HK CHANNEL</u>	<u>PARAMETER</u>	<u>RANGE</u>
AX-01	83	INNER TEMPERATURE	-160°C to +120°C
AX-02	30	CELL TEMPERATURE	+27°C to +160°C
AX-03	56	OUTER TEMPERATURE	-160°C to +120°C
AX-04	84	#1 CELL (BARE) OUTPUT	0 to 140 MW/CM ²
AX-05	26	#2 CELL (IRRADIATED) OUTPUT	0 to 140 MW/CM ²
AX-06	41	#3 CELL OUTPUT	0 to 140 MW/CM ²

Figure 3-11

3.5.2.2 Apollo Lunar Surface Drill (ALSD)

The Apollo lunar surface drill (ALSD) is used to enable one astronaut to collect subsurface cores and to emplant heat flow temperature probes below the lunar surface.

Implanting the temperature probes requires drilling of two subsurface holes to a maximum depth of three meters. The holes are cased, as necessary, to prevent cave-in and to facilitate insertion of the probes. Subsurface cores resulting from the drilling operation will be removed from the drill string after completion of the first hole. The core from the second hole will be returned to Earth within the drill string in the sample return container.

3.5.2.2.1 ALS D Physical Description

The ALS D is a hand-held, battery-powered, rotary-percussion drill consisting of four major elements: a battery pack, power head, drill string, and accessory group (Figure 3-12).

ALS D Battery Pack. The battery pack comprises a magnesium case which houses the silver-zinc battery cells and power switch. The case is sealed and pressure is regulated by a relief valve. A thermal coating is applied to the outer surface of the case.

ALS D Power Head. The power head is a self-contained device comprised of a round, cast-magnesium housing which interfaces with the battery pack and the drill string and which contains the major elements: motor, power train, clutch, percussor, and environmental controls.

ALS D Drill String. The drill string comprises a transport system, extension tubes, coupling joints, and a drill bit. The transport system consists of helical flutes machined into the outer wall of the extension tubes and drill bit. The drill bit extension tubes are eight, 17-inch long, titanium tubes approximately one-inch in diameter with the inside diameter maintained to permit coring. The drill bit is a steel cylinder with five tungsten-carbide cutter tips brazed into the lower face and the upper face threaded to mate with the drill bit extension tubes. The bit produces a hole 1.032 inches in diameter and a core approximately 0.802 inch in diameter.

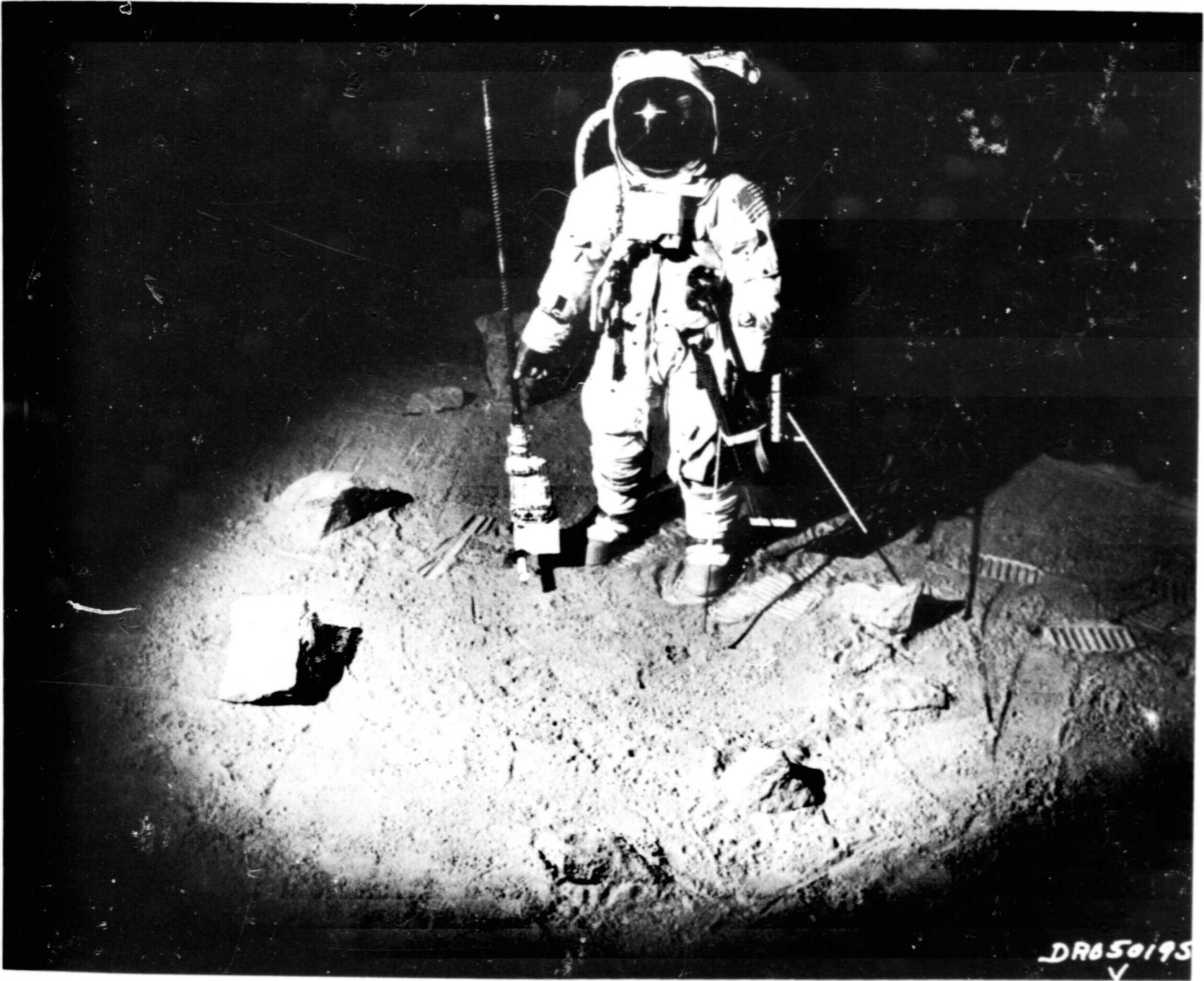

Figure 3-12 ALSID Components

ALSD Accessory Group. The accessory group includes the hole casing tubes, and the handles assembly.

A series of thin-walled (0.025-inch) fiberglass hole casing tubes are inserted down the hole, after removal of the drill string, to prevent cave-in of the hole. It is drilled down the hole, using a closed bit.

The handle assembly provides the means for astronaut control of the ALSD in the operational mode. The handle assembly incorporates a power on/off trigger, a trigger lock, and spring clips for coupling the handle to the battery pack case.

3.5.2.2.2 ALSD Functional Description

The ALSD is a battery-powered, rotary-percussion drill. The rotary-percussion drilling principle is used in this application because: the axial bit pressure and rotary torque requirements for efficient drilling are considerably less than for rotary drilling; drill bit operating temperatures are sufficiently low to preclude a requirement for bit coolant; and the tungsten-carbide cutters will drill with reasonable efficiency in the presence of a small dust layer in the bottom of the hole which is inherent with a mechanical cuttings transport system.

Power is supplied from the 16-cell silver-oxide-zinc battery to the power head motor at 23 vdc. The nominal speed of the motor armature is 9300 rpm. A reduction gear couples the output shaft of the motor to the power train which consists of the necessary reduction gears to provide the desired rotary motion and percussive action.

The interface between the power train and the percussor is provided by the clutch. The clutch limits the torque load to a level which can be safely controlled by the astronaut. (The clutch is designed for a nominal slip value of 20 foot-pounds.)

The percussor converts the uniform rotary output motion of the power train into pulsating, high-energy, short-duration, linear-impact blows to the output shaft of the power head. The impact action is accomplished by a rotating cam against a cam follower, which also serves as the hammer. As the cam rotates, the follower raises, cocking a spring. The spring, by virtue of the cam shape, releases its energy rapidly, thereby accelerating the hammer toward a transition section. This transition section, or power head shaft, serves as the anvil for the hammer and as the receiver for the rotary motion output of the power train.

The rotary-percussive energy at the output of the power head is coupled to the drill bit by the drill string. The clockwise helical flutes machined in the extension tubes and the drill bit are compatible with the direction of rotation of the power head so that cuttings are carried up the hole to the surface.

SECTION 4

DESIGN VERIFICATION

The ALSEP Array A2 design has been verified in the same manner as the flight 1 system. This section discusses the major configuration changes incorporated in Array A2 and various factors considered in establishing the test requirements. The rules by which tests have been performed and the manner in which data are collected are also described. Next, test results are arrayed against design requirements to show that system requirements are met and verified by actual measurement. Finally, detailed results of both system and subsystem tests are listed to completely substantiate the assertion that the system design is mature and flight-worthy.

The major differences between ALSEP Flight System 2A and the Flight System 1 Configuration are:

1. Bendix-designed transmitter, replaced the Philco Unit
2. Modified Dust-Temperature-Radiation and Engineering Measurement unit (DTREM)
3. Resettable solid state timer, replacing 2-year fixed timer
4. Bendix-designed analog multiplexer with switchable redundancy replacing Dynatronics Unit
5. Incorporation of HFE in the experiment complement.

4.1 OBJECTIVES OF TEST PROGRAM

The ALSEP Flight 2A test program is divided into two major phases: qualification and acceptance.

The object of the qualification test program is to demonstrate, at the component level, specification compliance, compatibility with system functions, and capability to withstand the effects of natural and induced environments.

The objective of the acceptance test program for flight hardware is to demonstrate that the flight unit's performance is within specification.

4.2 TEST PHILOSOPHY

The ALSEP Flight 2A program uses flight hardware that has been qualified under the ALSEP Flight 1 system with the exception of the transmitter, the timer, the multiplexer, the DTREM and the Heat Flow experiment. Therefore, with these exceptions this program requires only acceptance testing of the flight hardware.

The Level "A" Spare dust detector S/N-8 has been modified to the BxA drawing 2341440 configuration and accepted in the 2A flight system.

The Resettable Solid State Timer (RSST) was qualified and accepted at the subcontractor's facility, and also accepted as part of the Flight 2A system acceptance tests.

The transmitter and multiplexer were qualified at the component level. Acceptance testing of the transmitter and multiplexer was also accomplished at the component level and compatibility was confirmed during system acceptance tests.

The Heat Flow Experiment was qualified at the experiment level during the Qual SB program.

4.2.1 GFE Requirements

The following items (one each) of GFE were furnished to the contractor for use as a part of the 2A Flight System:

- A. LSM (2330657)
- B. SWS (2330658)

- C. SIDE (2338104)
- D. ALHT (SGB 39101165)
- E. RTG (47E 300779)
- F. Flight Handling Tool (47E 300452)
- G. Fuel Cask
- H. Fuel Capsule (to KSC)

4.2.2 Acceptance Test Program

The acceptance test program consists of pre-acceptance tests and acceptance tests. The pre-acceptance tests are performed at the component and subsystem level to demonstrate compliance with performance and test specifications. This provides a firm base for progressing into system level functional and environmental tests.

The pre-acceptance tests start with lower level assemblies, as shown in Figure 4-1. Vendor items (and experiments) follow the test sequence shown in Figure 4-2.

The acceptance tests comprise the following types of test:
1) System performance tests, 2) Baseline reference tests for environmental tests, 3) Environmental tests, and 4) Post-Environmental tests.

System performance tests demonstrate compatible functioning of the subsystems when they are interconnected as a system, and demonstrate that manufacturing tolerance build-ups are at acceptable levels.

Baseline reference tests provide nominal performance data to serve as a basis for comparison with corresponding performance data obtained during system environmental tests or after exposure to environmental testing.

Environmental tests demonstrate compliance with performance specifications under simulated operational environments.



TYPICAL
IN-HOUSE COMPONENT FLOW DIAGRAM

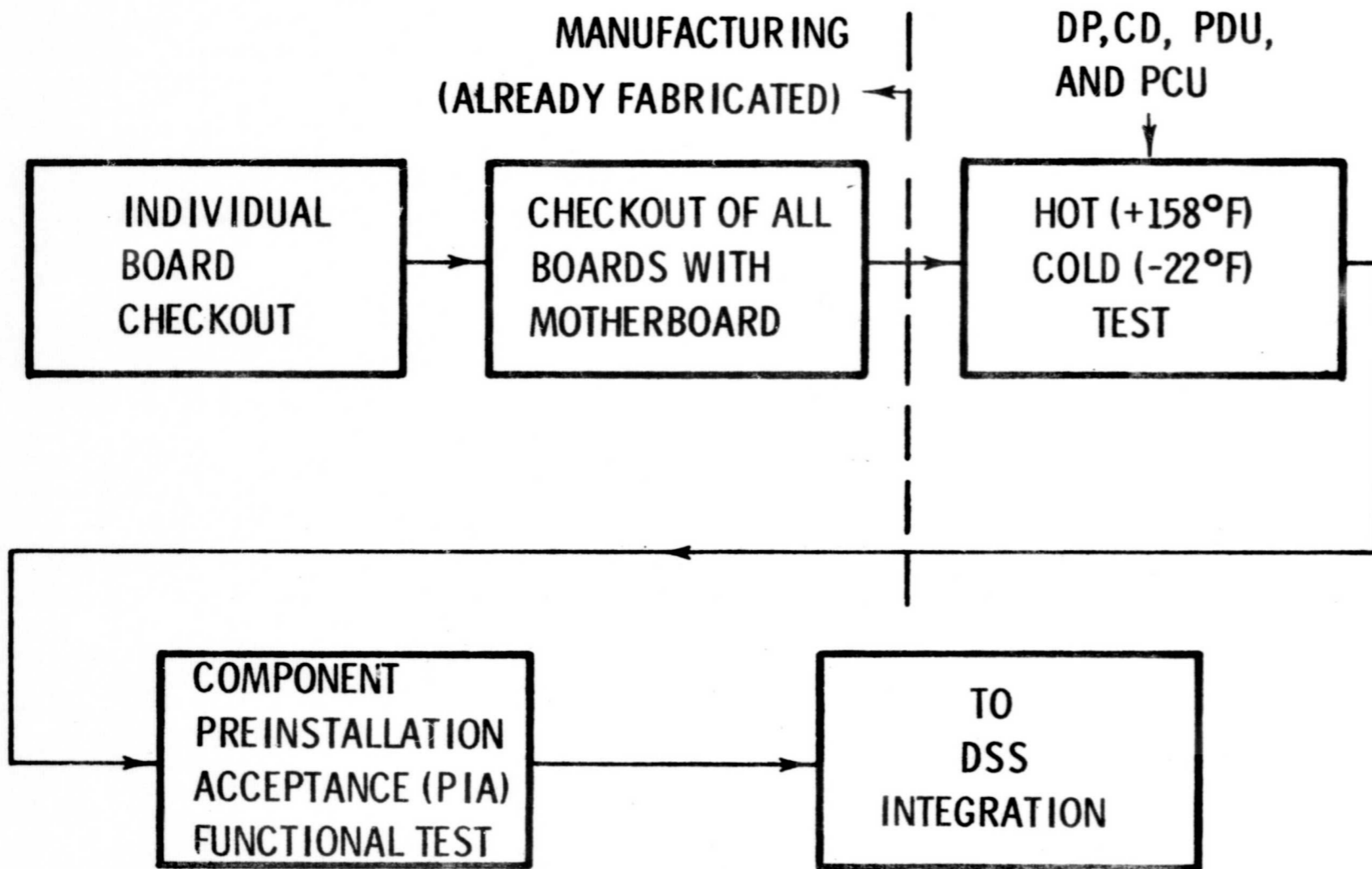

Figure 4-1



FLOW DIAGRAM

5844-85

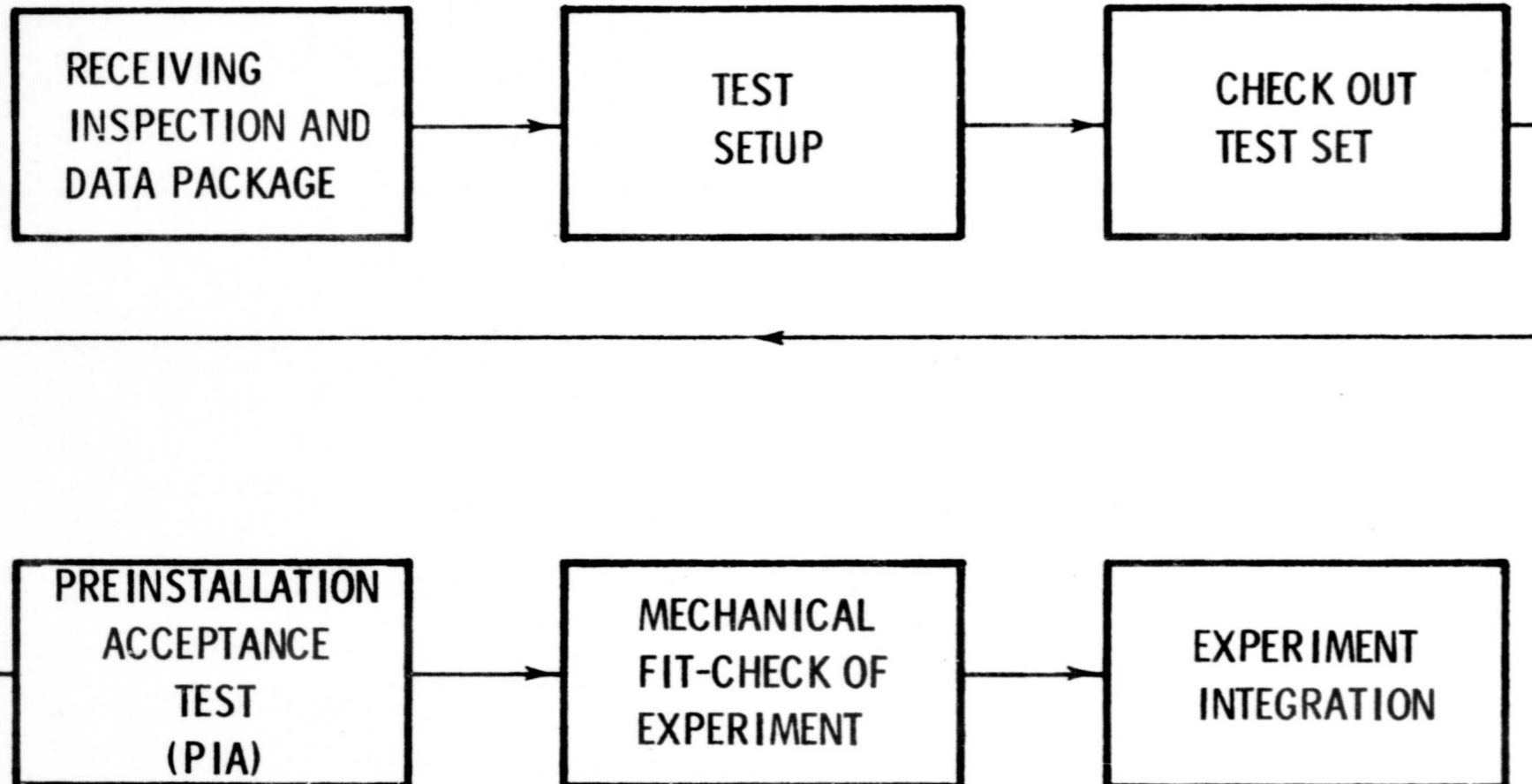

Figure 4-2

Certain acceptance tests were performed prior to the decision to integrate the HFE. At that time the test program was stopped and all acceptance tests were run after the design changes required for HFE were incorporated.

Post-environmental tests include two types. One type demonstrates that the performance specifications are still being met after exposure to environmental conditions. The second type provides performance data after exposure to environments not only to demonstrate specification compliance, but also to show that any change in performance data from the baseline reference test data is within acceptable limits.

4.2.3 Flight Acceptance Test List

The acceptance tests performed on the Flight 2A system hardware, are as follows: (Not sequential)

- A. Antenna VSWR
- B. Central Station Power Dissipation Test
- C. Central Station EMI
- D. IST with IPU
- E. System EMI Test
- F. RTG Leak Check
- G. PSE Sensor Visual Inspection
- H. Mass Properties S/P #1 and #2
- I. Vibration Test S/P #1 and #2
- J. Tumble Test S/P #1 and #2
- K. Magnetic Properties Test
- L. Modified IST
- M. Boydbolt Verification Test
- N. LSM, SWS, PSE, HFE and SIDE PIA Tests
- O. RTG Leak and Functional Tests
- P. Thermal Vacuum Test.

Open Door IST

Morning IST

Noon IST

Crosstalk Test

Night IST

SIDE Transition (Morning) Test

Open Door IST

- Q. PSE Sensor Visual Inspection
- R. LSM PIA
- S. RTG Leak
- T. RTG Shorting Plug PIA
- U. Antenna VSWR Test
- V. Antenna Pointing Mechanism
- W. Antenna Radiated Power Test
- X. Modified IST

4.3 TEST RESULTS AND DESIGN REQUIREMENTS SUMMARY

In this section, a comparison is made between subsystem requirements and measured results for A2 hardware. In addition, the components required for the A2 system are identified by serial numbers.

Some differences exist between the Qualification and A2 models; the differences are identified in this section. Included are electrical, thermal and mechanical changes which have occurred.

Each change has been carefully reviewed to determine the degree of impact, if any, on system qualification. In nearly all cases, design variations are so slight that they are considered qualified by similarity. In the remaining cases, additional tests have been performed. Therefore, a determination was made that most differences between qualification and flight hardware do not significantly impact system qualification.

4.3.1 System Configuration

A summary of the serial numbers of components used in the Qual and A2 Models is shown in Figures 4-3, and 4-4. Major design differences between the Qual and A2 Model are listed in Figure 4-5.

4.3.2 Qualification Tests

All A2 components which differ materially from the Qual SA, SB models and the Flight 1 system design have been subjected to special qualification tests.

The qualification test definition was predicted to provide a high level of confidence in the design prior to performance of formal acceptance tests.

The components separately qualified are:

1. Central Station Timer (RSST)
2. Analog Multiplexer
3. Transmitter
4. The Heat Flow Experiment
5. The Heat Flow Subpallet

Results of these qualification tests are presented in Figures 4-6 through 4-9.

	<u>QUAL SA</u>	<u>FLIGHT A2</u>
SUBPACKAGE 1	S/N-3	S/N-16
CENTRAL STATION	S/N-3	S/N-8
RECEIVER	S/N-4	S/N-11
COMMAND DECODER	S/N-2	S/N-9
DATA PROCESSOR	S/N-3	S/N-4
MULTIPLEXER/ CONVERTER	S/N-7 (Dynatronics)	S/N-11 (Bendix)
TRANSMITTER	S/N-7 & 9 (Philco)	S/N-26 & 27 (Bendix)
DIPLEXER FILTER	S/N-5	S/N-9
DIPLEXER SWITCH	S/N-5	S/N-9
POWER DISTRIBUTION MODULE	S/N-4	S/N-8
POWER CONVERTER UNIT	S/N-3	S/N-9
PSE ELECTRONICS MODULE	S/N-1	S/N-7
TIMER	S/N-2 (Bulova)	S/N-5 (Gulton)
WIRING HARNESS	S/N-3	S/N-11
THERMAL BAG	S/N-5	S/N-9
THERMAL PLATE	S/N-2	S/N-9
PASSIVE SEISMIC SENSOR SHROUD	S/N-2	S/N-10
SOLAR WIND EXPERIMENT	S/N-6	S/N-7
LUNAR SURFACE MAGNETOMETER	S/N-2	S/N-7
ANTENNA	S/N-4	S/N-5
DUST DETECTOR	S/N-3	S/N-10 (DTREM MOD.)
SUNSHIELD	S/N-3	S/N-5

Figure 4-3 A2 Hardware Summary Subpackage No. 1

	<u>QUAL SA</u>	<u>QUAL SB</u>	<u>FLIGHT A2</u>
SUBPACKAGE 2	S/N-3		S/N-15
RTG	MOD-15		S/N-632006
ALSEP DEPLOYMENT TOOLS			
UNIVERSAL HANDLING TOOL	S/N-3 & 4		S/N-11 & 12
CASK CAP REMOVAL TOOL	S/N-2		S/N-6
FUEL TRANSFER TOOL	S/N-2		S/N-6
PSE STOOL	S/N-1		S/N-7
ANTENNA AIMING MECHANISM	S/N-4		S/N-7
ANTENNA GIMBAL BOX	S/N-2		S/N-6
SUPRATHERMAL ION DETECTOR	S/N-3		S/N-7
HEAT FLOW		S/N-2	S/N-6

Figure 4-4 A2 Hardware Summary Subpackage No. 2

	<u>QUAL</u>	<u>A2</u>
SUBPACKAGE 1		
CARRY SOCKETS	EHT	UHT
DUST DETECTOR SENSOR	ORIG. DESIGN	DTREM MOD.
SUBPACKAGE 2		
CARRY SOCKETS	EHT	UHT
RTG FRAME ISOLATION	909 OHMS	3010 OHMS
ANTENNA AIMING MECHANISM	SINGLE-KEY ALIGNMENT	DOUBLE-KEY ALIGNMENT
CENTRAL STATION		
SCREENED PARTS	MOST	ALL
TRANSMITTER	PHILCO	BENDIX
ANALOG MULTIPLEXER	DYNATRONICS	BENDIX (MOS FET DESIGN)
TIMER	BULOVA	GULTON RSST
HARNESS	-----	MOD. FOR TIMER AND HFE
LSM		
PEDESTAL RELEASE	TOOL	LANYARD
GAMMA RANGES	-----	HIGHER SENSITIVITY
SIDE		
LOW ENERGY DETECTORS	1 APERTURE	TWO APERTURES
V FILTER DESIGN	-----	ADDED KNIFE EDGES
HV PROTECTION	-----	IMPROVED
GND SCREEN	-----	ADDED SPRING
ANALYZER COVER	-----	MODIFIED
CCIG	-----	LOW PRESSURE SCALE CHANGE
DEPLOYMENT LEGS	BASE ONLY	BASE AND SIDE
HEAT FLOW EXPERIMENT	ARRAY D	MODIFIED MOUNTING BRACKET

Figure 4-5 Comparison of A2 and Qualification Models (page 1 of 2)

	<u>QUAL</u>	<u>A2</u>
PASSIVE SEISMIC EXPERIMENT CSE:		
SHORT PERIOD BOARD	-----	NEW BOARD
POWER CONVERTERS	-----	NOISE IMPROVEMENT
MOTHERBOARD AND CABLE ASSY	-----	LACING AND CLAMPING IMPROVEMENT
LONG PERIOD CIRCUITS	-----	FREQ RESPONSE IMPROVEMENT
RIGHT SUPPORT ASSY	-----	ADD TIMER CHANGE
SENSOR:		
MECHANICAL DESIGN	-----	NEW DELTA RODS
LP AMPS	-----	NEW TERMINALS
LP ELECTRONICS	-----	ADDED PADS UNDER XFMRS
SP PREAMP	-----	GND REF ADDED
LEVELING GEAR DRIVE	-----	ADDED SPANNER HOLES
HEATERS AND THERMAL CONTROL	-----	HIGHER POWER DESIGN
SHROUD		
INSULATION	-----	ADDED LAYERS
WEIGHTS	-----	ADDED
GNOMON ASSY	-----	ADDED
STOOL		
FOOTPADS	-----	ENLARGED
SENSOR SUPPORT	BUTTONS	UPRIGHT SPACERS
SOLAR WIND EXPERIMENT		
HEATER POWER	3 W	4 W
HV GAIN STEPS	(2) ^{1/2}	(2) ^{3/4}
THERMAL DESIGN	-----	ADDED CONSTANTAN, THERMAL PAINT DELETED SIDE CURTAINS
CARRY SOCKET	EHT	UHT
DC OFFSET	0 = 5g	0 = 20g
FOOTPAD CONES	-----	SET SCREW LOCK

Figure 4-5 Comparison of A2 and Qualification Models (page 2 of 2)



SUBSYSTEM: DATA		TYPE OF TEST: QUAL		HARDWARE 2338511	
PERFORMANCE CHARACTERISTICS	REQUIREMENTS	RESULTS	CONCLUSIONS		
1. DIMENSIONS	2.00" x 2.80 x 1.38" MAX	1.997"x2.796x1.376"	QUALIFIED		
2. WEIGHT	< 7.35 OZ	6.6 OZ	QUALIFIED		
3. CURRENT	< 20 MA @ 12 V	10.5 MA @ 12 V	QUALIFIED		
4. PERFORMANCE	1-MINUTE, 18 HOUR, 1.5 MONTH PULSES AND 3-MONTH RELAY CLOSURE, RESET	COMPLY	QUALIFIED		
5. VIBRATION SINE	3-AXIS, 5.5 G PEAK, 7-2000 Hz, 0.75 OCT/MIN	NO DAMAGE	QUALIFIED		
RANDOM (LAUNCH & BOOST)	3-AXIS, 5.7 G RMS 2 1/2 MINUTES	NO DAMAGE	QUALIFIED		
RANDOM (LUNAR DESCENT)	3-AXIS, 4.3 G RMS 12 1/2 MINUTES	NO DAMAGE	QUALIFIED		
6. ACCELERATION	3-AXIS, BOTH DIRECTIONS 14 G, 1 MINUTE	NO DAMAGE	QUALIFIED		

Figure 4-6



SUBSYSTEM: DATA TYPE OF TEST: QUAL HARDWARE: 2338511

PERFORMANCE CHARACTERISTICS	REQUIREMENTS	RESULTS	CONCLUSIONS
7. SHOCK	3-AXIS, BOTH DIRECTIONS, 3 SHOCKS, 20 G PEAK, 11 MSEC.	NO DAMAGE	QUALIFIED
8. <u>THERMAL VACUUM</u>			
COLD	-22°F, 50 MICRON Hg 5 HOURS	PERFORMANCE OK	QUALIFIED
HOT	+158°F, 50 MICRON Hg 5 HOURS	PERFORMANCE OK	QUALIFIED
9. EMI	CONDUCTED AND RAD- IATED EMISSION BELOW SPECIFIED LEVELS	CONDUCTED OK RADIATED OUT OF SPEC BY 14db MAX	QUALIFIED QUALIFIED (WAIVER GRANTED)
	CONDUCTED AND RAD- IATED SUSCEPTIBILITY ABOVE SPECIFIED LEVELS	OK	QUALIFIED

Figure 4-6



ANALOG MUX AND ADC
(Ref. ATR-236)

SUBSYSTEM DATA	TYPE OF TEST	QUAL	HARDWARE	2338900A SN7
<u>PERFORMANCE CHARACTERISTICS</u>	<u>REQUIREMENTS</u>	<u>RESULTS</u>		<u>CONCLUSIONS</u>
<u>FUNCTIONAL</u>		<u>SIDE</u>		
		<u>X</u> <u>Y</u>		
AMBIENT	5V CURRENT < 140 MA	120, 118 MA		QUALIFIED
	12V CURRENT < 50 MA	31, 32 MA		
	15V CURRENT < 5 MA	4, 3 MA		
	-12V CURRENT < 50 MA	35, 34 MA		
	THERMISTOR VOLTAGE			
	1.5-2.5 V	1.954, 1.962 V		
		2.447, 2.068 V		
	MULTIPLEX 90 CHANNELS AND CONVERT TO 1-BIT ACCURACY	COMPLY		QUALIFIED
COLD (-20°F)	AS ABOVE (EXCEPT THERMISTOR)	COMPLY		QUALIFIED
HOT (+ 140°F)	AS ABOVE (EXCEPT THERMISTOR)	COMPLY		QUALIFIED
<u>CROSSTALK</u>				
AMBIENT	C. T. LESS THAN .005V FOR ALL CHANNELS	COMPLY		QUALIFIED

Figure 4-7 (1 of 3)



SUBSYSTEM	DATA	TYPE OF TEST	QUAL	HARDWARE	2338900A S/N 7
PERFORMANCE CHARACTERISTICS		REQUIREMENTS	RESULTS		CONCLUSIONS
	COLD (-22°F)	C. T. LESS THAN .005V FOR ALL CHANNELS	COMPLY		QUALIFIED
	HOT (+ 158°F)	C. T. LESS THAN .005V FOR ALL CHANNELS	COMPLY		QUALIFIED
<u>WEIGHT</u>		< 2.61 LBS.	1.83		QUALIFIED
<u>VIBRATION</u>					
	SINE	THREE-AXIS 5-100 Hz 5.5 G PEAK	NO DAMAGE		
	RANDOM (LAUNCH & BOOST)	3-AXIS 10-2000 Hz .07 G ² /Hz PEAK, 2.5 MIN.	NO DAMAGE		
	RANDOM (LUNAR DESCENT)	3-AXIS 10-2000 Hz .052G ² /Hz PEAK, 12.5 MIN.	NO DAMAGE		QUALIFIED
<u>SHOCK</u>		20 G PEAK, 11 MSEC + X, ± Y AND Z 3 SHOCKS EACH DIRECTION	NO DAMAGE		QUALIFIED

Figure 4-7 (2 of 3)

Bendix
**Aerospace
Systems Division**



ANALOG MUX AND ADC (CONT)

(Ref. ATR - 236)

SUBSYSTEM	DATA	TYPE OF TEST	QUAL	HARDWARE
2338900A S/N 7				
PERFORMANCE CHARACTERISTICS		REQUIREMENTS		RESULTS
				CONCLUSIONS
<u>THERMAL VACUUM</u>				
	-22°F, 10 ⁻⁵ TORR	FUNCTIONAL, AS ABOVE		COMPLY
	+160°F	FUNCTIONAL, AS ABOVE		COMPLY
				QUALIFIED
				QUALIFIED

Figure 4-7 (3 of 3)



TRANSMITTER

SUBSYSTEM	DATA	TYPE OF TEST	QUAL	HARDWARE P/N 2344600 S/N 21
TEST OBJECTIVE		REQUIREMENTS	RESULTS	CONCLUSIONS
FUNCTIONAL CHECK PERFOR- MANCE IN AIR AT -22°F +78°F AND + 158°F		IN LIMIT OPERATION	HARMONIC OUT- PUTS O. T.	HARMONICS ARE FILTERED BY DIPLEXER SWITCH AND FILTER AND ARE NOT MEA- SURABLE AT THE ANTENNA
NON-OPERATING VIBRA- TION SUBJECT TEST ITEM TO DESIGN LIMIT VIBRATION ENVIRONMENT		NO DAMAGE OR CHANGE IN PERFORMANCE	NO CHANGES	IN COMPLIANCE
OPERATING VIBRATION QUALIFY FOR USING OPERATING VIBRA- TION ACCEPTANCE TEST		NO CHANGE IN MONITORED PARAMETERS	NO CHANGES	IN COMPLIANCE

Figure 4-8 (1 of 3)

Bendix
Aerospace
Systems Division



TRANSMITTER

SUBSYSTEM	DATA	TYPE OF TEST	QUAL	HARDWARE P/N 2344600 S/N 21
TEST OBJECTIVE	REQUIREMENTS	RESULTS	CONCLUSIONS	
SHOCK				
SUBJECT TEST ITEM TO DESIGN LIMIT SHOCK ENVIRONMENT	NO DAMAGE OR CHANGE IN PERFORMANCE	NO CHANGES	IN COMPLIANCE	
THERMAL VACUUM SUBJECT TEST ITEM TO THERMAL VACUUM ENVIRONMENT	PROPER PERFORMANCE OVER TEMPERATURE RANGE OF -22°F TO +158°F	PROPER PERFORMANCE EXCEPT FOR POWER TELEMETRY WHICH WAS O. T. by 0.5db	IN COMPLIANCE OF TRANSMITTER SPECIFICATION- POWER TELEMETRY O. T. WILL NOT ADVERSELY AFFECT SYSTEM PERFORMANCE	

Figure 4-8 (2 of 3)

29



TRANSMITTER

SUBSYSTEM DATA TYPE OF TEST QUAL HARDWARE P/N 2344600 S/N 21

TEST OBJECTIVE	REQUIREMENTS	RESULTS	CONCLUSIONS
<p>EMI</p> <p>CHECK TEST ITEM FOR COMPLIANCE WITH EMI REQUIREMENTS</p>	<p>TRANSMITTER SHALL NOT CAUSE ALSEP TO EXCEED SYSTEM EMI REQUIREMENTS</p>	<p>SEVERAL O. T. CONDITIONS WERE NOTED IN TRANSMITTER TEST BUT NONE CAUSE A SYSTEM O. T. CONDITION</p>	<p>TRANSMITTERS ARE USEABLE IN THE ALSEP SYSTEM WITHOUT ADVERSELY AFFECTING PERFORMANCE AND NO INTERFERENCE WITH OTHER SYSTEMS WILL OCCUR</p>

Figure 4-8 (3 of 3)



HEAT FLOW AND SUBPALLET

SUBSYSTEM: Heat Flow Exp. TYPE OF TEST: Qual HARDWARE: D SN-2 HFE & D SUBPALLET

TEST OBJECTIVE	REQUIREMENTS	RESULTS	CONCLUSION
Check Performance in air at 10°C and 60°C and vacuum \approx 20°C	In Limit Operation	No changes	Complies
Non-Operating Vibration: Subject test item to Design Limit Vibration Environment.	No damage or change in performance	Proper Performance	Complies
Thermal Vacuum subject test item to Thermal Vacuum environment	In limit operation	Proper performance on Qual SB	Qualified by Similarity to QSB
Shock			
Subject test item to Design Limit Shock Environment.	In limit operation	Proper Operation	Complies

Figure 4-9

4.3.3 Acceptance Test Results

Results of acceptance tests performed on the A2 flight system are presented in Figures 4-10 through 4-22.

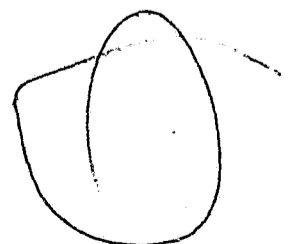

Bendix
**Aerospace
Systems Division**



**SUBPACKAGE 1
MASS PROPERTIES**

CHART NO. _____
DATE: _____
SPEAKER: _____

TEST OBJECTIVE	REQUIREMENTS	RESULTS	CONCLUSIONS
TO DETERMINE THE WEIGHT AND CENTER OF GRAVITY OF SP-1	WEIGHT: MAX. = 125 LBS MIN. = 75 LBS CG: XA= 10.985 IN. YA= 12.445 IN. ZA= 12.045 IN.	WEIGHT: 123.45LBS CG: XA= 8.359 YA= 12.864 ZA= 10.910	WITHIN ALLOWABLE DEVIATION-- ACCEPTABLE

4-24

Figure 4-10



SUBPACKAGE 2
MASS PROPERTIES

CHART NO. _____
DATE: _____
SPEAKER: _____

TEST OBJECTIVE	REQUIREMENTS	RESULTS	CONCLUSIONS
TO DETERMINE WEIGHT AND CENTER OF GRAVITY OF SP-2	WEIGHT: MAX: 215 LBS MIN: 75 LBS CG: XA = 10.985 IN YA = 12.445 IN ZA = 12.045 IN	SP-2 WEIGHT: 96.42LBS CG: XA = 9.178 IN YA = 12.534 IN ZA = 12.991 IN	WITHIN ALLOWABLE DEVIATION-- ACCEPTABLE
TO DETERMINE WEIGHT AND CENTER OF GRAVITY AFTER ADDITION OF HFE TO SP-2	WEIGHT: MAX: 135 LBS MIN: 75LBS CG: SAME AS ABOVE	WEIGHT: 104.19 LBS XA = 9.608 IN YA = 13.185 IN ZA = 11.966 IN	WITHIN ALLOWABLE DEVIATION -- ACCEPTABLE

4-25

Figure 4-11

Bendix
**Aerospace
Systems Division**



SUBPACKAGE 2
MAGNETIC PROPERTIES

CHART NO. _____

DATE: _____

SPEAKER: _____

TEST OBJECTIVE	REQUIREMENTS	RESULTS	CONCLUSIONS
TO VERIFY THAT SP-2 COMPLIES WITH MAGNETIC PROPERTIES REQUIREMENTS OF NAS 9-5829, EXHIBIT B.	VECTOR SUM PERMANENCE: LESS THAN 15 GAMMA	10.8 GAMMA	TEST ACCEPTED AS RUN
RE-RUN MAGNETIC PROPERTIES TEST AFTER ADDITION OF HFE TO SP-2	SAME AS ABOVE	12.18 GAMMA	TEST ACCEPTED AS RUN

4-26

Figure 4-12



**Aerospace
Systems Division**



SUBPACKAGE 1
MAGNETIC PROPERTIES
TEST

CHART NO. _____

DATE: _____

SPEAKER: _____

TEST OBJECTIVE	REQUIREMENTS	RESULTS	CONCLUSIONS
TO VERIFY THAT SP-1 COMPLIES WITH THE MAGNETIC REQUIREMENTS OF ALSEP TECHNICAL SPECIFICATION, EXHIBIT B OF NAS 9-5829	VECTOR SUM PERMANENCE: LESS THAN 15 GAMMA	4.27 GAMMA	TEST ACCEPTED AS RUN

Figure 4-13



SUBPACKAGE 2
ACCEPTANCE VIBRATION

CHART NO. _____

DATE: _____

SPEAKER: _____

TEST OBJECTIVE	REQUIREMENTS	RESULTS	CONCLUSIONS
TO SUBJECT SP-2 TO ACCEPTANCE VIBRATION LEVELS IN EACH OF 3 ALSEP AXES.	<p>SINE: 5-100-5HZ RATE 1.5 OCT/MIN ALL AXES 1.15 G PEAK</p> <p>LAUNCH ROOST RANDOM:</p> <p>X = 4.5 GRMS DURATION: 1 MIN</p> <p>Y = 3.2 GRMS DURATION: 1 MIN 10-2000 HZ</p> <p>Z = 4.1 GRMS DURATION: 1 MIN 10-2000 HZ</p>	<p>DR AB8042 NOTED X AXIS SINE INPUT 1.28G INSTEAD OF 1.15G. THIS OVER- TEST CONDITION CONSIDERED INSIGNI- FICANT. NO EFFECT ON TEST RESULTS OR EQUIPMENT.</p> <p>DR AB7500 NOTED PLASTIC STRIPS ON SIDE OF <u>SIDE</u> EXPERIMENT UN- BONDED AFTER X AXIS RANDOM VIBRATION. NO OTHER DISCREPANCIES OR DAMAGE TO FLIGHT HARDWARE NOTED AS RESULT OF VIBRATION TESTS.</p>	<p>TESTS ACCEPTED-- DR AGAINST <u>SIDE</u> WAS CLOSED AFTER REPAIR OF <u>SIDE</u> AT RICE UNIVERSITY</p>

Figure 4-14



SUBPACKAGE 2
ACCEPTANCE VIBRATION
(RE-RUN)

CHART NO. _____
DATE: _____
SPEAKER: _____

TEST OBJECTIVE	REQUIREMENTS	RESULTS	CONCLUSIONS
TO SUBJECT SP-2 TO ACCEPTANCE VIBRATION LEVELS AFTER ADDITION OF THE HEAT FLOW EXPERIMENT	SINE: 5-100-5 HZ RATE 3 OCT/MIN. ALL AXES LAUNCH AND BOOST RANDOM: Z = 4.1 GRMS DURATION: 1 MIN 10-2000 HZ Y = 3.2GRMS DURATION: 1 MIN 10-2000 HZ X = 4.5GRMS DURATION: 1 MIN 10-2000 HZ	DR'S AB9465, 9467 AND 9573 WERE WRITTEN AGAINST VIBRATION IN- PUT OVERSHOOTS. SUBSEQUENT INSPEC- TIONS AND PIA TESTS REVEALED NO DAMAGE TO FLIGHT HARDWARE.	TEST ACCEPTED DR'S WERE CLOSED AS TEST EQUIP- MENT DISCREPAN- CIES ONLY.

4-29

Figure 4-15



SUBPACKAGE 1
ACCEPTANCE
VIBRATION

CHART NO. _____
DATE: _____
SPEAKER: _____

TEST OBJECTIVE	REQUIREMENTS	RESULTS	CONCLUSIONS
TO SUBJECT SP-1 TO ACCEPTANCE VIBRATION LEVELS IN EACH OF 3 ALSEP AXES	SINE: 5-100-5 HZ RATE 1.5 OCT/MIN ALL AXES 1.15 G PEAK LAUNCH BOOST RANDOM: Z = 4.1 GRMS DURATION: 1 MIN 20-2000 HZ Y = 3.2 GRMS DURATION: 1 MIN 20-2000 HZ X = 4.5 GRMS DURATION: 1 MIN 20-2000 HZ	NO DISCREPANCIES OR DAMAGE AGAINST AS RUN. FLIGHT HARDWARE NOTED.	TEST ACCEPTED

Figure 4-16



ALSEP SYSTEM EMI

CHART NO. _____

DATE: _____

SPEAKER: _____

TEST OBJECTIVE	REQUIREMENTS	RESULTS	CONCLUSIONS
TO DETERMINE THAT THE ALSEP SYSTEM WOULD NOT BE AFFECTED BY EXTERNAL SPURIOUS EMI AND THAT THE ALSEP WOULD NOT GENERATE OBJECTIONAL INTERFERENCE.	(REF AL770000) VARIOUS SPECIFICATION LEVELS 150 MHZ TO 10 MHZ. RADIATED INTERFERENCE BROADBAND AND NARROWBAND.	IN COMPLIANCE	TEST SUCCESSFUL NO DISCREPANCIES
	ANTENNA CONDUCTED BROADBAND AND NARROWBAND	IN COMPLIANCE	
	RADIATED SUSCEPTIBILITY	IN COMPLIANCE	
	ALL APOLLO FREQUENCIES CHECKED	IN COMPLIANCE	

Figure 4-17



CENTRAL STATION EMI

CHART NO. _____
 DATE: _____
 SPEAKER: _____

TEST OBJECTIVES	REQUIREMENTS	RESULTS	CONCLUSIONS
<p>TO DETERMINE THAT (REF. AL 770000) THE CENTRAL STATION DOES NOT GENERATE OBJECTIONAL INTERFERENCE, THAT IT IS NOT SUSCEPTIBLE TO EXTERNAL RADIATION AND THAT THERE IS ADEQUATE MARGINS FOR OPERATION OF THE EXPERIMENT SUB-SYSTEMS.</p>	<p>(REF. AL 770000) VARIOUS SPECIFICATION LEVELS GENERALLY 10DB MORE SEVERE THAN SYSTEM REQUIREMENTS</p> <p>CONDUCTED INTERFERENCE 15KHZ TO 25 MHZ.</p>	<p>THREE FREQUENCIES ABOVE PROCEDURES LIMITS ON 29 VOLT LINES</p> <p>A. SEVERAL FREQUENCIES ABOVE PROCEDURE LIMITS BELOW 2MHZ. B. 190MHZ & 760MHZ LINES ABOVE PROCEDURE LIMITS.</p>	<p>NO AFFECT ON SYSTEM PERFORMANCE & NOT OT TO SYSTEM REQUIREMENTS</p> <p>A. NO EFFECT ON SYSTEM. B. WAIVER 0009 GRANTED. LEVELS ARE NOT ABOVE SPEC. LIMITS.</p>
	<p>RADIATED INTERFERENCE 15 KHZ TO 10GHS</p>		
	<p>ANTENNA CONDUTED INTERFERENCE 150KHZ TO 10 GHZ</p>	<p>NO INTERFERENCE</p>	<p>IN COMPLIANCE</p>

Figure 4-18 (page 1 of 2)

4-32



**CENTRAL STATION EMI
(CONTINUED)**

CHART NO. _____
DATE: _____
SPEAKER: _____

TEST OBJECTIVE	REQUIREMENTS	RESULTS	CONCLUSIONS
	ANTENNA CONDUCTED SUSCEPTIBILITY 150 KHZ TO 10 GHZ	NO SUSCEPTIBILITY	IN COMPLIANCE
	RADIATED SUSCEP- TIBILITY 15 KHZ TO 10GHZ	NO SUSCEPTIBILITY	IN COMPLIANCE
	AF & RF CONDUCTED SUSCEPTIBILITY 50 HZ TO 25MHZ	NO SUSCEPTIBILITY	IN COMPLIANCE



POWER DISSIPATION TEST

CHART NO. _____

DATE: _____

SPEAKER: _____

TEST OBJECTIVES

REQUIREMENTS

RESULTS

CONCLUSIONS

PRIOR TO HFE INTEGRATION

DETERMINE CENTRAL STATION POWER DISSIPATION AND CALIBRATE INPUT VOLTAGE, INPUT CURRENT AND RESERVE POWER FOR ALL LOAD CONDITIONS

CENTRAL STATION DISSIPATION LESS THAN 25 WATTS AND OBTAIN CALIBRATION CURVES FOR TELEMETRY WITHIN PROCEDURE LIMITS

TEST RESULTS WERE SATISFACTORY.

POWER PARAMETERS WERE CALIBRATED

RERUN AFTER HFE INTEGRATION

SAME AS ABOVE

SAME AS ABOVE

TEST RESULTS WERE SATISFACTORY

POWER PARAMETERS WERE RE-CALIBRATED

Figure 4-19



INTEGRATED SYSTEM TEST

CHART NO. _____

DATE: _____

SPEAKER: _____

OBJECTIVES

OPERATE THE COMPLETE ALSEP SYSTEM IN AMBIENT AIR ENVIRONMENT AND CHECK ALL MODES OF OPERATION OF ALL SUBSYSTEM.

REQUIREMENTS

ALL SUBSYSTEMS MUST OPERATE WITHIN LIMITS SPECIFIED IN TEST PROCEDURE

RESULTS

NO SIGNIFICANT OUT-OF-TOLERANCE CONDITIONS WERE NOTED.

CONCLUSIONS

TEST WAS SUCCESSFUL, SYSTEM PERFORMANCE NOMINAL.

RERUN AFTER HFE INTEGRATION

SAME AS ABOVE

SAME AS ABOVE

ONE DR WAS WRITTEN AS A RESULT OF A FAILURE OF ONE RTG SENSOR. ONE DR WAS WRITTEN AS A RESULT OF LSM INCORRECT READOUT.

TEST WAS SUCCESSFUL. GENERAL WAIVER HAS BEEN GRANTED FOR RTG TEMPERATURE SENSOR. FR A-19 WAS WRITTEN ON LSM. LANYARD WAS REPLACED AND VERIFIED.

Figure 4-20



**Aerospace
Systems Division**



THERMAL VACUUM

CHART NO. _____

DATE: _____

SPEAKER: _____

OBJECTIVES

VERIFY SYSTEM
ELECTRICAL & THER-
MAL PERFORMANCE
IN SIMULATED LUNAR
ENVIRONMENTS

REQUIREMENTS

ALL SUBSYSTEMS MUST
OPERATE WITHIN
TEST PERFORMANCE OF
THE "LUNAR DAWN,"
"LUNAR NOON" AND
"LUNAR NIGHT" SIMULA-
TIONS OF TEMPERA-
TURE AND VACUUM.

RESULTS

TEST RESULTS WERE
NOMINAL WITH THE
FOLLOWING EX-
CEPTIONS:

- 1) DISCREPANCY
REPORT AB9249 DOCU-
MENTED A DATA "DROP
OUT" ASSOCIATED WITH
THE PSE EXPERIMENT.
CONDITION CAUSED BY
INTERMITTENT CONN-
ECTOR(S). CONDITION
CORRECTED BY
CLEANING OF CONN-
ECTORS (REF. FR A15)
- 2) LSM EXHIBITED AN
INTERMITTENT "DIGITAL INT TO USE.
FILTER" AS DOCUMENTED
ON AB 9241 REF. FR A16.
WAIVER WAS REQUESTED
ON THE BASIS THAT
DIGITAL FILTER CAN BE

CONCLUSIONS

CONDITION
CORRECTED BY
REWORK, REF
FR A15

NO CONSTRA-
INT TO USE.

Figure 4-21 (page 1 of 3)



THERMAL VACUUM
(CONTINUED)

CHART NO. _____
DATE: _____
SPEAKER: _____

OBJECTIVES	REQUIREMENTS	RESULTS	CONCLUSIONS
		<p>BYPASSED AND IS NOT REQUIRED FOR SATIS- FACTORY OPERATION.</p>	
		<p>3) LSM SENSOR STATUS IMPROPER AS DOCU- MENTED ON AB9243, FR A18 WRITTEN AND REWORK PERFORMED AT PHILCO FORD.</p>	<p>NO CONSTRAINT TO USE AFTER REWORD EFFECTED</p>
		<p>4) SIDE CALIBRATION OUT OF TOLERANCE. AS DOCU- MENTED ON AB9245. CON- DITION PREVIOUSLY DOCUMENTED ON AB6106 AND REPORTED ON FR 273.</p>	<p>NO CONSTRAINT TO USE.</p>
		<p>5) A SHORT OCCURRED BETWEEN THE GENERATOR ELECTRICAL CAPSULE & CHAMBER GROUND PROHIBITING OPERATION OF THE RTG WITH THE SYSTEM. DR AB8581.</p>	<p>NO CONSTRAINT TO USE. THIS RTG HAS BEEN OPERATED WITH THIS SYSTEM IN THE 1ST AND THIS RTG HAS</p>

Figure 4-21 (Page 2 of 3)

4-37



**THERMAL VACUUM
(CONTINUED)**

CHART NO. _____

DATE: _____

SPEAKER: _____

OBJECTIVES

REQUIREMENTS

RESULTS

CONCLUSIONS

BEEN PREVIOUSLY
ACCEPTANCE
TESTED IN VACUUM.
THERE WAS NO
DAMAGE TO ANY
FLIGHT EQUIP-
MENT AS A RESULT
OF THE SHORT.

Figure 4-21 (Page 3 of 3)



MODIFIED INTEGRATED SYSTEM
SYSTEM TEST AND RADIATED
POWER

CHART NO. _____

DATE: _____

SPEAKER: _____

OBJECTIVES

DETERMINE THE OPERATION INTEGRITY OF THE SOLAR WIND, PASSIVE SEISMIC, MAGNETOMETER & CENTRAL STATION SUBSYSTEMS AFTER SUBPACKAGE NO. 1 HAS BEEN SUBJECTED TO THE VIBRATION TEST ENVIRONMENT AND TO VERIFY FINAL FLIGHT CONNECTIONS AFTER FINAL ASSEMBLY.

REQUIREMENTS

ALL MEASUREMENTS & FUNCTIONAL PARAMETERS MUST BE WITHIN PROCEDURE LIMITS

RESULTS

ALL MEASUREMENTS WERE WITHIN LIMITS

CONCLUSION

TEST WAS SUCCESSFUL

Figure 4-22

4-39

SECTION 5

OPERATIONS PLANNING

5.1 KSC OPERATIONS

5.1.1 General

The ALSEP KSC Operations consist of equipment inspections, fit checks to interfacing systems, installation of the ALSEP on the LM and implementing cask cooling. The ALSEP hardware which is installed on the spacecraft includes:

1. Fuel Cask Structure Assembly
2. Graphite LM Fuel Cask (GLFC)
3. Fuel Capsule Assembly (FCA)
4. ALSEP Subpackages No. 1 and No. 2.

The Graphite Lunar Module Fuel Cask (GLFC) contains the Fuel Capsule Assembly (FCA) during flight and is held on cradles near the LM main structure adjacent to the SEQ bay, where ALSEP is stowed. This location was chosen to minimize heat transmission by the SNAP-27 fuel capsule into the LM descent stage cryogenic tanks.

The GLFC was designed to provide optimum re-entry properties to the fuel capsule in case of orbital abort. The GLFC is held by precisely pretensioned bands of titanium alloy; the pretension compensates for the differential thermal expansion between launch pad conditions and lunar space at the graphite/titanium interface. The cradles hold the GLFC away from the LM and provide a capsule deployment mechanism for the astronaut which accommodates unfavorable landing positions of the LM.

The FCA contains the encapsulated radioisotope fuel (Pu 238) to meet nuclear safety criteria. The FCA is a thin-walled cylindrically-shaped structure with an end plate assembly required for integration into the generator assembly.

The FCA thermal output (radiated and conducted) will not exceed 1550 w, and its temperature will not exceed 1350°F when carried in open air. The FCA will be inserted in the GLFC at approximately T-16 hours after the LM LHe Tanks have been topped off and the lines removed from the SLA.

The cask cooling system on the launch pad limits the GLFC surface temperature to about 170°F which is considerably lower than the maximum (350°F) necessary for ignition of hypergolic vapors or fuel leaks. Loss of cooling after the FCA has been inserted will result in the GLFC surface temperature increasing at 40°F per minute to a maximum of 650°F.

The cask cooling system will be activated before the FCA is inserted in the GLFC and will function continuously until liftoff. At about T-8 hours, the cooling system will be switched from air to nitrogen and will operate continuously until vehicle launch and, in the event of a scrubbed flight, through detanking, nitrogen to air switchover, and until the FCA has been removed from the GLFC.

To provide real-time data regarding the operation of the cooling system, a pressure transducer is located at the base (large cross section) of the cooling nozzle, and a temperature sensor is located on the upper band of the cask mounting hardware behind the right upper trunnion.

ALSEP Subpackages No. 1 and No. 2 are installed in the LM SEQ bay.

5.1.2 ALSEP KSC Activities

The activities associated with ALSEP are centered in the ALSEP Launch Preparation Site (ALPS) which is located in Hangar "S", CKAFS. All ALSEP subsystems are received, inspected, fit checked, tested, and prepared for launch at this location. After launch preparations are completed, the ALSEP subpackages are transported to the launch pad and installed in the LM SEQ Bay at approximately T-45 days.

The installation of the GLFC/Structure Assembly on LM in the Spacecraft LM adapter (SLA) will be accomplished on the launch pad at about T-30 days. The FCA is installed on the launch pad at about T-12 hours.

5.1.3 KSC Test Checkout Requirements

The ALSEP test checkout activities at KSC consist of inspections of flight hardware and its associated Ground Support Equipment (GSE), fit checks, astronaut crew deployment, software integration test, ALSEP preparation for flight, and installation in LM on the launch pad.

5.2 CREW OPERATIONS

The deployment task sequence for array A2 is defined in Bendix report ATM-939, "ALSEP Configuration A-2 Two-Man Deployment Task Sequence." This section summarizes information pertinent to the deployment operations.

The following assumptions and conditions are applicable to the deployment sequence:

1. The sequence is for a two-man deployment.
2. The Lunar Module (LM) is oriented on the lunar surface with the Scientific Equipment Bay (SEQ) facing southeast.
3. The commander and the LM Pilot maintain constant voice contact while deploying ALSEP.
4. The voice link between the command/LM pilot and Mission Control Center (MCC), during ALSEP deployment, is through the LM directly to MCC.
5. The Commander and the LM Pilot are pressurized to 3.75 psi in Extravehicular Mobility Units (EMU) during ALSEP deployment.
6. The times in hours, minutes, and seconds are based on part-task tests conducted with Crew Engineering mock-ups.

A condensed timeline is presented in Figure 5-1. The condensed timeline is essentially a major task flow analysis along a time base, showing the major points of interaction between the two crewmen. The detailed timeline in ATM-939 lists, in sequence of performance, each of the steps required to carry out the main tasks identified in the condensed timeline. It is in the detailed timeline that the crew/equipment interfaces are revealed. Both timelines present the CDR's and LMP's tasks side-by-side so that no confusion will exist as to which crewman is doing what, or how the two cooperate in the operations on the lunar surface.

Figure 5-1

ALSEP A-2 CONDENSED TIMELINE

Task No.	CDR	Time	Task No.	LMP	Time
				<u>ALSEP OFFLOAD</u>	
			P1.0	Open SEQ Bay Doors	00:00:00
			P2.0	Offload ALSEP Pkgs.	00:01:00
C1.0	<u>LRV STOWAGE</u>	00:04:00			
			P3.0	Fuel RTG	00:07:00
			P4.0	Configure ALSEP for Traverse	00:12:30
			P5.0	Close SEQ Bay Doors	00:15:00
				<u>LRV STOWAGE ASSIST</u>	
C2.0	Offload LR ³ (300)	00:22:00	P6.0	Stow Quad III Equip. Pallet on LRV	00:22:00
			P7.0	Stow LR ³ (300) on LRV Rt. Seat	00:24:00
C3.0	<u>FLAG DEPLOY AND COMM. CHECK</u>	00:29:30	P8.0	<u>S-BAND SWITCH AND FLAG DEPLOY</u>	00:29:30
C4.0	<u>ALSEP TRAVERSE (ON LRV)</u>	00:40:30		<u>ALSEP TRAVERSE</u>	
			P9.0	Walk to ALSEP Site	00:40:30
			P10.0	Position ALSEP at Site	00:52:00
	<u>ALSEP SYSTEM INTERCONNECT</u>			<u>ALSEP SYSTEM INTERCONNECT</u>	
C5.0	Offload HTC	00:53:00			
C6.0	Offload HFE	00:54:45			
C7.0	Connect HFE to C/S	00:56:10			
			P11.0	Remove Subpallet	00:56:30
			P12.0	Remove SIDE	00:57:30
			P13.0	Connect SIDE to C/S	00:59:15
C8.0	Connect RTG to C/S	01:00:15			
C9.0	Carry HFE Subpallet to Deployment Site	01:03:00			
	<u>HFE SITE SET-UP</u>			<u>PSE DEPLOYMENT</u>	
C10.0	Offload HFE	01:06:30	P14.0	Deploy PSE Stool	01:06:30
C11.0	Deploy 1st Probe	01:08:30			
			P15.0	Deploy PSE	01:11:30

ALSEP A-2 CONDENSED TIMELINE (continued)

Task No.	CDR	Time	Task No.	LMP	Time
C12.0	<u>DRILL SET-UP</u>	01:15:00	P16.0	Level & Align PSE	01:15:00
			P17.0	<u>SWS DEPLOYMENT</u>	01:16:00
			P18.0	<u>LSM OFFLOAD</u>	01:20:00
				<u>CENTRAL STATION</u>	
				<u>DEPLOYMENT</u>	
			P19.0	Erect Sunshield	01:23:00
C13.0	<u>HFE PROBE #1</u> Implant Drill Stem #1	01:28:30	P20.0	Erect Antenna	01:30:30
			P21.0	Level & Align Antenna	01:33:00
				<u>SIDE DEPLOYMENT</u>	
			P22.0	Implace SIDE	01:40:30
C14.0	Insert Probe #1	01:42:30	P23.0	Deploy CCIG	01:46:30
	<u>HOLE #2 SET-UP</u>				
C15.0	Transfer Equipment	01:47:00	P24.0	Level & Align SIDE	01:47:00
C16.0	Deploy 2nd Probe	01:50:00			
	<u>HFE PROBE #2</u>			<u>LSM DEPLOYMENT</u>	
C17.0	Implant Drill Stem #2	01:53:00	P25.0	Implace LSM	01:53:00
			P26.0	Level & Align LSM	01:54:45
			P27.0	<u>C/S ACTIVATION</u>	01:57:00
			P28.0	<u>LRRR DEPLOYMENT</u>	02:01:00
			P29.0	<u>ALSEP PHOTOGRAPHY</u>	02:05:00
C18.0	Insert Probe #2	02:07:00			
C19.0	Remove HFE Electronics Pkg.	02:10:30			
C20.0	<u>CORE SAMPLING</u>	02:13:00			

5-5

3

SECTION 6

PROBLEMS AND CORRECTIVE ACTIONS

The major technical problems encountered in the production of ALSEP A2 are discussed in Figures 6-1 through 6-5.



PROBLEM: FAILURE OF TIMER
TO RESET RELIABLY (DATA
SUBSYSTEM)

I. Statement

The resettable solid state timer (RSST) failed to reset by command during system integration tests of the RSST Engineering Model with the prototype ALSEP Central Station. Analysis indicated that the trouble occurred only during specific counter states and was caused by the varying load on the reset line, which sometimes exceeded the reset drive capability. Other timer functions were not adversely affected.

II. Significance

This problem falls into criticality category 3. It appears that persistent repetition of the reset command would eventually achieve reset under the most adverse circumstances.

III. Solution

The reset circuitry was redesigned by the subcontractor, Gulton, to reduce the drive impedance while still holding the "low" voltage level of the reset line down sufficiently to ensure reliable counter operation. The following specific changes were required:

1. Replace series resistors R22 and R23 (5.1K) with 1.0K resistors.
2. Replace FET Q22 with conventional transistor, type TX 2N2222A.
3. Remove diode CR 9 (1N914).

IV. Substantiating Data

After modification with the above changes, the Engineering Model RSST was completely retested with supply voltages of 10, 12, and 14 VDC (nominal is 12) over the Qual temperature range, with satisfactory results. Subsequently, the Qual and Flight units have also been modified and successfully tested using the same procedure.

V. Conclusions

Test results have confirmed that the engineering change will result in reliable resetting of the timer by ground command while operating on the lunar surface. The solution poses no constraints on ALSEP operation.

VI. Effectivity and Implementation Status

The change has been incorporated into all units covered by the RSST subcontract. S/N 5 (allocated to ALSEP A2) was tested and accepted on 4/10/70.



**Aerospace
Systems Division**



**PROBLEM: POOR RELIABILITY
RECORD OF ANALOG MULTIPLEXER
(DATA SUBSYSTEM)**

I. Statement

The analog multiplexer used in the Flight 1 design has a history of excessive failure during subsystem and system testing. Analysis of the failures indicates the cause to be contamination of plastic materials used for encapsulation of FET's and other transistors. Trouble appears to be time-related and most pronounced after a storage period.

II. Significance

This problem falls into criticality category 3. Failure of the multiplexer would reduce the amount of the engineering data derived from a mission, but would still permit most of the scientific data to be telemetered.

III. Solution

A new multiplexer (2338900A) has been designed and produced, featuring the following changes:

1. Plastic-encapsulated discrete components have been replaced with integrated circuits performing similar design functions.
2. A fully redundant multiplexer is provided, switchable, in synchronism with the digital data processor selection, by ground command.

IV. Substantiating Data

Reduction of total parts count (and selection of high-reliability parts) has resulted in a more reliable unit. Extensive testing of an engineering model, qual model, and flight unit has been conducted.

V. Conclusions

Test results have confirmed that the new design will result in more reliable operation of the multiplexer. The redundant unit is switched with the associated digital processor and poses no constraints on ALSEP operation.

VI. Effectivity and Implementation Status

The new multiplexer (applicable only to A2) was retrofitted into the A2 Central Station on 6/12/70.

Figure 6-2



**PROBLEM: R. F. CABLE
STOWAGE RELEASE
FAILURE**

- I. **Statement**
During crew fit and functional exercises @ KSC, the r. f. cable stowage assembly mechanism would not release during deployment.
- II. **Significance**
This problem falls into criticality category 3 because the failure would result in loss of data if the ALSEP Antenna could not be properly deployed.
- III. **Solution**
Mechanical modifications to the stowage mechanism were made (Ref. CRD 58945 and 58946) to correct problem.
- IV. **Conclusions**
Cable stowage mechanism now deploys properly and will pose no constraint on A2 deployment.
- V. **Effectivity and Implementation Status**
Changes have been incorporated on Array A2.



**PROBLEM: PSE CONNECTOR
PINS OPENING AT LOW
TEMPERATURE**

- I. **Statement**
During thermal vacuum testing, certain pins of connector J35 apparently opened causing loss of/erratic PSE housekeeping and scientific data.
- II. **Significance**
Problem falls into category 3 because failure causes loss of scientific PSE data.
- III. **Solution**
Cause of problem was determined to be contaminated connector pins which opened when subjected to low temperature testing.
All similar PSE/CSE connectors shall be visually inspected with a 40X microscope. Contaminated connectors will be cleaned with Unresolve Plus. New connectors will be bonded in strict accordance with appropriate manufacturing processes.
- IV. **Conclusions**
Correct implementation of assembly processes and procedures should preclude problem recurrence.
- V. **Effectivity and Implementation**
Changes have been incorporated in Array A2.

Figure 6-4



PROBLEM SUMMARY

ITEM	PROBLEM	SOLUTION	A2 STATUS	
			CLOSED	OPEN
1.	PSE CONNECTOR PINS OPENING AT LOW TEMPERATURES DUE TO CONTAMINATION	CLEAN ALL CONNECTORS CURRENTLY IN USE—BOND NEW CONNECTORS PER APPROPRIATE PROCESSES AND PROCEDURES	X	
2.	R. F. CABLE STOWAGE MECHANISM NOT RELEASING DURING DEPLOYMENT	INCORPORATE MECHANICAL MODS TO STOWAGE MECHANISM	X	
3.	EXCESSIVE FAILURE OF CENTRAL STATION MUX DURING SUBSYSTEM AND SYSTEM TESTS	REPLACE MUX WITH NEW DESIGN	X	
4.	FAILURE OF RSST TO RESET WHEN COMMANDED	MODIFY DESIGN OF RESET CIRCUITRY TO PROVIDE PROPER OPERATION	X	

Figure 6-5

SECTION 7

DESIGN CERTIFICATION

7.1 BASIS FOR CERTIFICATION

Certification of ALSEP design maturity and the suitability of the scientific experiments package for use on a manned-flight mission is based on an evaluation of the following:

1. Design analyses
2. Test readiness reviews
3. Results of extensive testing.

7.1.1 Design Analyses

As an integral part of the ALSEP reliability program, a detailed design analysis was conducted on each new major component incorporated into the A2 design. The reports documenting these analyses provided confidence in the adequacy of the design, verifying appropriate applications and redundancy of parts and circuitry. A listing of these reports is included in Figure 7-1.

The summary of ALSEP reliability predictions is shown in Figure 7-2.

7.1.2 Design Reviews

Principally because of the design revisions required to accommodate the HFE, a series of design reviews was held. These reviews, conducted



DESIGN ANALYSIS REPORTS

TIMER	ATM-845	12/11/69	RELIABILITY OF TELEDYNE RELAYS
	-846	12/3/69	RELIABILITY OF RSST & ALTERNATE DESIGNS
	-849	12/15/69	COMMAND DECODER INTERFACE
ANTENNA	ATM-842	11/3/69	TOLERABLE POINTING ERROR
TRANSMITTER	ATM-854	2/5/70	FMECA
	-856	2/17/70	RELIABILITY PREDICTION
ANALOG MULTIPLEXER	ATM-860	3/19/70	PARTS APPLICATION ANALYSIS
STRUCTURE/THERMAL	ATM-844	12/5/69	FUEL CASK COOLING
ELECT. POWER	ATM-852	1/23/70	FMEA FUEL CAPSULE INTERFACE

FIGURE 7-1



ALSEP RELIABILITY PREDICTIONS
FOR A2

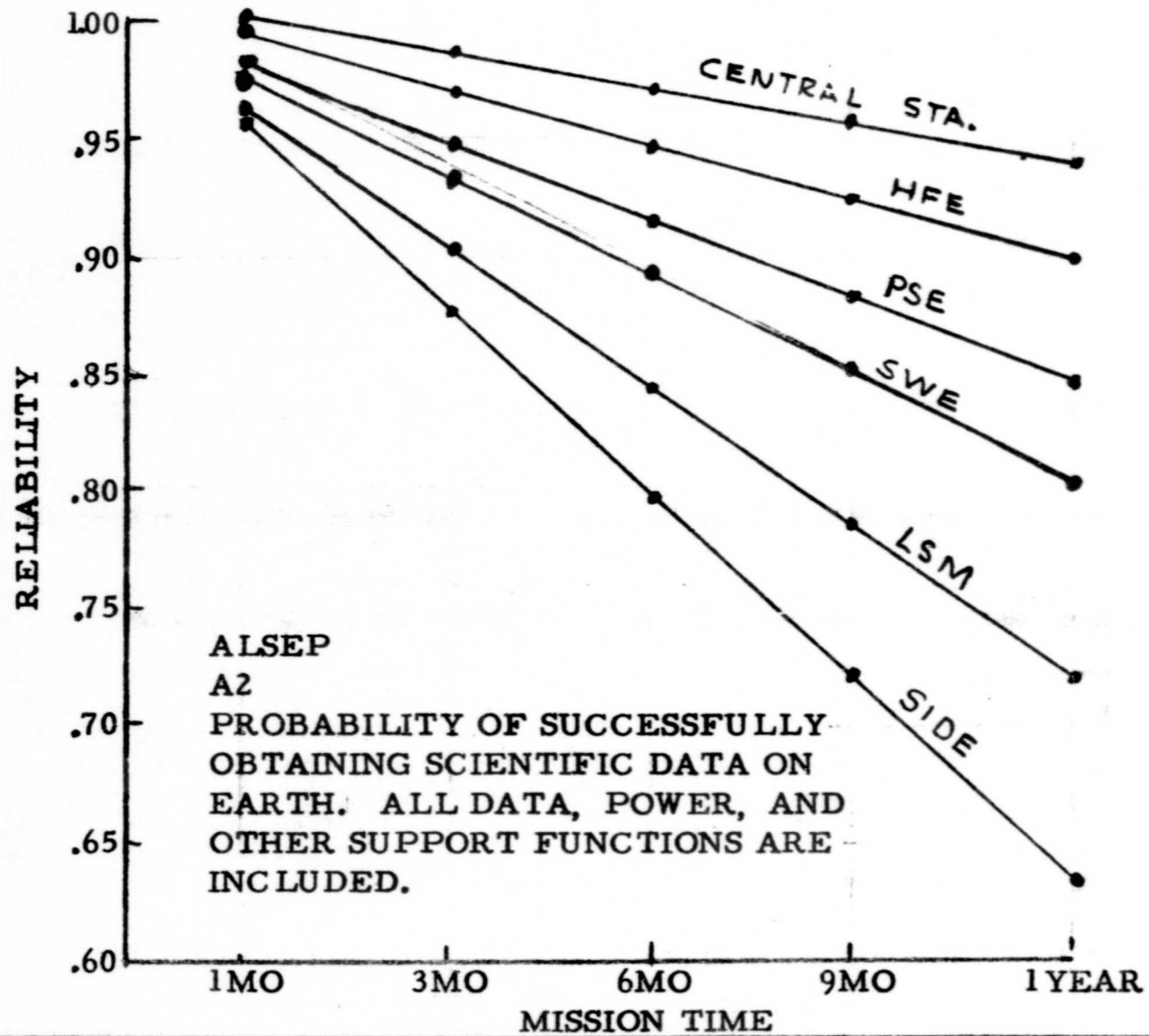

FIGURE 7-2

7-3
9-3

by teams of NASA specialists, were scheduled at appropriate points in the design phase. Highlights of each review are described below.

The Central Station Preliminary Design Review (PDR) was held on August 3, 1970, at Bendix Aerospace Systems Division in Ann Arbor, Michigan. The Critical Design Review (CDR) was held on 14-15 September, 1970 at Bendix Aerospace Systems Division in Ann Arbor, Michigan. Only four chits were generated as a result of the reviews, none were directly concerned with hardware design.

7.1.3 Flight Test Readiness Review

To verify the suitability of Array A2 equipment, documentation, and facilities for acceptance Flight Test Readiness Reviews were held on 10-27-70 (SP-1) and 12-15 & 16-70 (SP-2). At these reviews, problems and action items were stated and discussed and permission was obtained to proceed with the Acceptance Test program.

7.1.4 Test Results

The extensive design limit and mission simulation tests performed on Qual Hardware and the acceptance tests performed on A2 hardware, considering their functional identity, have resulted in a high level of confidence in the suitability of ALSEP A2 for the lunar mission.

Results of the A2 tests have been documented in the series of test reports listed in Figure 7-3.

7.2 Open Items

A list of open items for the A2 program is shown in Figure 7-4.



ALSEP TEST REPORTS

<u>TEST</u>	<u>ATR NO.</u>	<u>A2</u> <u>DATE</u>
Central Station Power Diss.	217	1-21-71
IST (with IPU)	218	1-21-71
System EMI	219	2-4-71
SP-1 Mass Properties	220	1-19-71
SP-2 Mass Properties	273	A - 4-21-71
SP-1 Vibration	222	3-10-71
SP-2 Vibration	274	A-4-21-71
SP-1 Tumble	224	1-21-71
SP-2 Tumble	233	A - 4-21-71
SP-1 Magnetic Properties	226	9-21-71
SP-2 Magnetic Properties	227	3-15-71

Figure 7-3 (Page 1 of 2)

7-5



ALSEP TEST REPORTS

<u>TEST</u>	<u>A2</u>	
	<u>ATR NO.</u>	<u>DATE</u>
SP-1 BOYDBOLT VERIFICATION	228	4-14-71
SP-2 BOYDBOLT VERIFICATION SP-2 UHT FIT CHECK	229	4-21-71
THERMAL/VACUUM ACCEPT. (1ST) (ENV)	230	4-28-71
POST-VIBRATION MODIFIED 1ST	231	4-14-71
PRE-SHIPMENT MODIFIED 1ST AND RF LINK VERIFICATION	232	3-25-71
QUALIFICATION TRANSMITTER	233	3-5-71
QUALIFICATION RESETTABLE SOLID STATE TIMER (RSST)	234	-
MULTIPLEXER	236	7-24-70
ANT VSWR ANT AIMING MECH. TEST	238	3-9-71
RTG LEAK AND FUNCTIONAL	239	2-4-71

FIGURE 7-3 (PAGE 2 OF 2)

7-6



A-2 OPEN ITEMS

1. MSC APPROVAL OF WAIVER W0014-PSE CSE S/N 7 UNCAGE ANOMALIES DURING TEST (NO AFFECT ON PSE LUNAR MISSION OPERATION).
2. MSC APPROVAL OF AMES WAIVER REQUEST FOR INTERMITTENT OPERATION OF LSM S/N 7 DIGITAL FILTER (FILTER OPERATION "DESIRABLE" NOT "MANDATORY" FOR LUNAR OPERATIONS).
3. BENDIX TO VERIFY REWORK OF SIDE S/N 7 BY RICE UNIVERSITY TO CLOSE DR AB 9535, TO BE COMPLETED PRIOR TO DELIVERY OF SIDE TO KSC.

Figure 7-4

7.3 WAIVERS AND DEVIATIONS FROM SPECIFICATIONS

The approved waivers for Array A2 are listed in Figure 7-5.

7.4 STATEMENT OF CERTIFICATION

A statement of certification for the scientific experiments is shown in Figure 7-6.



APPROVED WAIVERS

1. W-001. USE OF REPAIRED HARDWARE AUTHORIZED. (COMPONENT BOARD OF SN11 MULTIPLEXER.) PER FORM DD1694 DATED 5-18-70.
2. W-007. WAIVER GRANTED TO "USE AS REPAIRED". COMPONENT BOARD OF SN11 MULTIPLEXER PER FORM DD1694 DATED 8-4-70.
3. W-008. WAIVER GRANTING USE OF A LIFTED PAD. PER FORM DD1694 DATED 9-10-70.
4. W-009. OUT OF TOLERANCE READINGS FROM THE "B" DOWNLINK TRANSMITTER. PER FORM DD 1694 DATED 1-12-71.
5. W-0014. PSE UNCAGE STATUS (SEE FIGURE 7.4).
6. RTG-1 RTG TEMPERATURE SENSORS.

FIGURE 7-5

APPENDIX A

GLOSSARY OF ABBREVIATIONS AND ACRONYMS

<u>Abbreviation or Acronym</u>	<u>Definition</u>
A/D	Analog-to-Digital
ADC	Analog-to-Digital Converter
ALHT	Apollo Lunar Hand Tools
ALSEP	Apollo Lunar Surface Experiments Package
AMU	Atomic Mass Units
ASSY	Assembly
ATM	ALSEP Technical Memorandum
ATP	Acceptance Test Procedure
ATR	ALSEP Test Report
BPS	Bits Per Second
BSR	Bendix Systems Report
BTU	British Thermal Units
BxA	The Aerospace Systems Division of The Bendix Corporation
C	Centigrade
CALIB	Calibration
CCCE	Cold Cathode Ion Gauge

<u>Abbreviation or Acronym</u>	<u>Definition</u>
CDRT	Cask Dome Removal Tool
CG	Center of Gravity
CH	Change or Channel
CM	Centimeters or Command Module
COMP	Compartment
CONT	Controlled or Continued
CR	Diode
CS	Central Station
CSE	Central Station Electronics (PSE)
CU	Cubic
D/A	Double Amplitude
DB	Decibels
DBM	Decibels (with respect to one milliwatt)
DC	Direct Current
DDP	Digital Data Processor
DIA	Diameter
DSS	Data Subsystem
DTR-EM	Dust, Thermal and Radiation Engineering Measurement
EGFU	Electronics/Gimbal Flip Unit
EHT	Experiment Handling Tool
EMI	Electromagnetic Interference

<u>Abbreviation or Acronym</u>	<u>Definition</u>
EMU	Extravehicular Mobility Unit
EPS	Electrical Power Subsystem
EV	Electron Volts
EVA	Extravehicular Activity
F	Fahrenheit
FET	Field Effect Transistor
FMEA	Failure Mode Effects Analysis
FMECA	Failure Mode Effects Criticality Analysis
FREQ	Frequency
FT	Feet
FTRR	Flight Test Readiness Review
FTT	Fuel Transfer Tool
G	Acceleration of Gravity
GAEC	Grumman Aircraft Engineering Corporation
GFE	Government Furnished Equipment
GHz	Gigahertz
GND	Ground
H	High
Hg	Mercury
HR	Hours
HV	High Voltage

Abbreviation or Acronym

Definition

Hz	Hertz (cycles per second)
IN.	Inches
IPU	Integrated Power Unit
IST	Integrated System Test
KEV	Kilo Electron Volts
KHz	Kilohertz
KSC	Kennedy Space Center
LB	Pounds
LGE	Lunar Geological Equipment
LM	Lunar Module
LP	Long Period
LSM	Lunar Surface Magnetometer
M	Meters
mA	Milliamperes
MAX	Maximum
ME	Magnetometer Experiment
mGAL.	Milligal
MHz	Megahertz
MIN	Minutes or Minimum
mSec	Milliseconds
MSFN	Manned Space Flight Network

<u>Abbreviation or Acronym</u>	<u>Definition</u>
N/A	Not Applicable
NRZ-L	Non-Return-to-Zero-Level
N-S	North-South
OCT	Octave
OZ	Ounces
PC	Power Conditioner
PCM	Pulse Code Modulation
PCU	Power Conditioning Unit
PDU	Power Dissipation Unit
PIA	Pre-Installation
PLSS	Portable Life Support System
PSE	Passive Seismic Experiment
Q	Transistor
QUAL	Qualification
R	Resistor
RCP	Right-Hand Circularly Polarized
REF	Reference
REP	Representative or Repetition
RF	Radio Frequency
RMS	Root-Mean-Square
RSST	Resettable Solid State Timer

<u>Abbreviation or Acronym</u>	<u>Definition</u>
RTG	Radioisotope Thermoelectric Generator
SCI	Science
SEC	Seconds
SENS	Sensitivity
SEQ	Scientific Equipment or Sequencer
SIDE	Suprathermal Ion Detector Experiment
S/N	Serial Number
S/P	Subpackage
SP	Short Period
SPEC	Specification
SRC	Sample Return Container
SWE	Solar Wind Experiment
SWS	Solar Wind Spectrometer
TM	Telemetry
T/V	Thermal/Vacuum
UHT	Universal Handling Tool
V	Volts
VDC	Volts, Direct Current
VSWR	Voltage Standing Wave Ratio
W	Watts
XFMR	Transformer

Abbreviation or Acronym

Definition

α

Absorptance (dimensionless ratio)

γ

Gamma, Unit of Magnetic Flux Density

ϵ

Emissivity (Dimensionless ratio)

μ

One-Millionth (10^{-6})