

N71-33018

NASA CR-121382

CASE FILE  
COPY

APOLLO CONTAMINATION ANALYSIS

FINAL REPORT

PART I

Grant NGR 09-015-105

July 1971

Prepared for  
National Aeronautics and Space Administration  
Washington, D.C. 20546

Smithsonian Institution  
Astrophysical Observatory  
Cambridge, Massachusetts 02138

APOLLO CONTAMINATION ANALYSIS

FINAL REPORT

PART I

Grant NGR 09-015-105

July 1971

Prepared for  
National Aeronautics and Space Administration  
Washington, D.C. 20546

Smithsonian Institution  
Astrophysical Observatory  
Cambridge, Massachusetts 02138

APOLLO CONTAMINATION ANALYSIS  
FINAL REPORT

PART I

MICRODENSITOMETER-MEASUREMENT TECHNIQUES  
AND DATA-REDUCTION PROCEDURES

TABLE OF CONTENTS

<u>Section</u>		<u>Page</u>
1	SUMMARY OF PROJECT ACCOMPLISHMENTS. . . . .	1
2	PHOTOGRAPHIC DATA. . . . .	3
	2.1 Baker-Nunn Films of Apollo Clouds . . . . .	3
	2.2 Step Wedges . . . . .	3
3	MEASURING AND RECORDING EQUIPMENT . . . . .	4
	3.1 Microdensitometer. . . . .	4
	3.2 Automatic Drive . . . . .	5
	3.3 DHE Equipment . . . . .	5
	3.4 Circuit for DHE Switch on Automatic Drive . . . . .	6
	3.5 Operating Instructions . . . . .	8
	3.5.1 Microdensitometer and automatic drive. . . . .	8
	3.5.2 DHE. . . . .	9
4	DATA PROCESSING . . . . .	13
	4.1 Format of Data on 9-Track Tape . . . . .	13
	4.2 Format of Data on 7-Track Tape . . . . .	15
	4.3 Conversion from DHE Position Units to Distance on Film . . . . .	15
	4.4 Interpolation Interval for Star and Cloud Frames. . . . .	16
	4.5 Processing of Step-Wedge Measurements . . . . .	17
	4.6 Calculation of Relative Exposure from Step Wedge . . . . .	18
	4.7 Average Density of Sky Background . . . . .	19
	4.8 Total Radiance of Cloud or Star Images . . . . .	20
	4.9 Radiance of Sky Background . . . . .	21
	4.10 Distance in Kilometers between Points on Cloud Image . . . . .	22
	4.11 Format of Cloud Data Tape . . . . .	22

TABLE OF CONTENTS (Cont.)

<u>Section</u>		<u>Page</u>
5	ANALYSIS . . . . .	24
	5.1 Symmetry Axes of Cloud . . . . .	24
	5.2 Plotting Symmetry Axes . . . . .	26
6	REFERENCES . . . . .	28

# Apollo Contamination Analysis

## Final Report

### Part I

#### MICRODENSITOMETER-MEASUREMENT TECHNIQUES AND DATA-REDUCTION PROCEDURES

##### 1. SUMMARY OF PROJECT ACCOMPLISHMENTS

The broad objectives of the Apollo Contamination Analysis project were a quantitative analysis of the clouds formed by liquids vented into space during Apollo missions and the generation of models representing the behavior of these clouds. This information is expected to be useful in evaluating the possibility that such clouds may contaminate various experiments carried on manned space missions. The behavior of the clouds is also interesting as a scientific topic in its own right.

The liquids released into space are primarily oxygen, hydrogen, or water. In the vacuum of space, a fraction of the released liquid immediately vaporizes, freezing the remaining material into a cloud of small solid particles.

The investigation was initiated as a joint effort between the Smithsonian Astrophysical Observatory (SAO) and Bellcomm. The principal investigator, Dr. Charles Buffalano, and his coinvestigators at Bellcomm devoted their main efforts to modeling the cloud phenomena. The SAO effort concentrated on the reduction of observational data.

The proposed scope of the project, as amended in January, 1970, emphasized reduction and analysis of the extensive photographic observations

of the clouds produced by the Apollo 12 mission. The project also encompassed additional, but supplementary, efforts to obtain and study observations of the clouds associated with the Apollo 13 and 14 missions.

The number of Baker-Nunn photographs to be analyzed from Apollo 12 required that film measurement and data processing be automated. Hence, SAO first adapted its microdensitometer to automatic digital operation. Appropriate computer programs were prepared to process the image-density measurements. The specific procedures used in the data reduction are documented in Part I of this report.

A substantial selection of the Apollo 12 data have been processed. Both hydrogen and oxygen clouds are represented in these data. This data base is the subject of Part II of this report.

Some limited data were obtained from Apollos 13 and 14, but the Apollo 12 data remain by far the most comprehensive. The observational material available on each of the Apollo missions is summarized within Part II of this report.

While Apollo 12 data analysis was in progress at SAO, the Bellcomm investigators refined their theory and models of the cloud phenomena (Buffalano, 1971; Sharma and Buffalano, 1971). The models were initially applied to oxygen data from earlier Apollo missions. However, the accuracy of these earlier data is inferior to that from Apollo 12 data (Lundquist, 1970). Sharma, Kratage, and Buffalano (1971) have also discussed the reported observations of water dumps from Apollo 12.

As a final step, the oxygen and hydrogen data from Apollo 12 Baker-Nunn photographs can be used with the cloud models. This is the subject of Part III of this report.

## 2. PHOTOGRAPHIC DATA

### 2.1 Baker-Nunn Films of Apollo Clouds

Three types of photographs are taken on each Baker-Nunn film of Apollo clouds. The first type consists of time exposures without the diffuser over the lens. These are the frames on which the cloud images are measured with the microdensitometer.

These regular time exposures of the cloud are alternated with frames taken while the diffuser is over the camera lens (Southworth, 1966). The diffuser spreads out the light from a star so that it can be measured with the microdensitometer and integrated for the purpose of calibrating the film. The cloud images on diffuser frames are not measured.

At the beginning and end of each film are frames containing step-wedge exposures for obtaining the D-log E curve of the film.

### 2.2 Step Wedges

The step-wedge images on films of Apollo clouds are produced by using an Eastman processing control sensitometer Model 60. The instrument contains a calibrated lamp, filters, and a step tablet. The step tablet contains 21 strips whose density varies from about 0.05 to 3.05 in steps of 0.15 (a factor of  $\sqrt{2}$  in intensity). The film is inserted in a slot behind the step tablet. When the button is pressed, a precisely timed 0.1-sec exposure is produced on the film.

Since the time exposures of the Apollo clouds are all considerably longer than 0.1 sec (up to 32 sec), the calibration from this sensitometer does not apply directly to the cloud photographs, because of the effect of reciprocity failure. A way to calibrate for longer exposures is to increase the density of the neutral-density filters and take multiple 0.1-sec exposures.

### 3. MEASURING AND RECORDING EQUIPMENT

The equipment used to measure Apollo cloud photographs consists of three separate units: a Joyce-Loebl microdensitometer model MK III C.S., an automatic drive manufactured by Technical Operations Inc., and the DHE (Data-Handling Equipment) manufactured by Astrodata for the Telescope Project.

#### 3.1 Microdensitometer

The Joyce-Loebl microdensitometer measures density by comparing the density of the sample to that of a calibrated gray wedge of continuously varying density. The light from a lamp is split into two beams, one of which passes through the sample, and the other through the gray wedge. A photomultiplier alternately reads the sample beam and the gray-wedge beam and moves the gray wedge through a servomechanism until the intensity of the two beams is equal. The gray wedge is physically connected to a pen that records the density on a piece of graph paper. The table holding the graph paper is connected through a ratio arm to the specimen table. As the specimen is scanned, the density at each point is recorded on the graph paper.

After the beam has passed through the sample, it is magnified by a factor of 10 and passes through a variable-sized opening before being measured by the photocell. The opening is a rectangular slit whose width and length can be adjusted. Alternatively, one can insert fixed-aperture plates to determine the opening. The microdensitometer being used has circular fixed-aperture plates of diameter 0.33, 0.5, 1.0, and 2.0 mm. With a magnification factor of 10, the sample areas being scanned are circles of diameter 33, 50, 100, and 200  $\mu$  for each of the plates.

The position of the pen can be adjusted by a zeroing knob so that the range of the pen is suitable for the aperture and density being measured. For very small apertures and high densities, the sample beam is so weak that noise in the amplifier may be a problem. At the other extreme of very

clear samples, it may be necessary to add filters in the path of the sample beam so that the signal can be balanced against the gray-wedge beam.

The ratio arm between the sample table and the recording table can be set for ratios 50, 20, 10, 5, 2, and 1. The recording table has a maximum traveling range of about 26 cm. The length of a scan on the sample is 26 cm divided by the lever ratio.

The sample table can be moved perpendicular to the direction of scan either an arbitrary amount or in multiples of 1.25 or 25  $\mu$ . When the sample is moved in discrete jumps, a counter records the number of jumps. The displacement perpendicular to the direction of scan is then the number of jumps times the step size selected (either 1.25 or 25  $\mu$ ).

### 3.2 Automatic Drive

This unit is part of an isodensitracer designed for making contour maps of the density of a sample. The unit being used contains only the part of the isodensitracer that drives the microdensitometer to scan automatically a rectangular area. The automatic drive controls the table movement and the stepping motor that moves the sample over to scan a new line. When the automatic drive is put into the automatic mode, the table is driven forward until the end of the scan is reached. The table is then put in reverse and the sample moved over to scan a new line. The automatic drive has five stepping switches that will cause the sample to be moved 1, 2, 4, 8, or 16 steps between each scan. With the proper combination of switches, the number of steps between each scan can be varied from 1 to 31. When the desired area has been scanned, the automatic drive is taken out of automatic mode to stop the scanning.

### 3.3 DHE Equipment

The DHE equipment is used for automatically digitizing and recording the density measurements made by the microdensitometer. There are three inputs to the DHE: a potentiometer linked to the density wedge to read density, a

potentiometer turned by the table as it scans the sample, and a switch for turning the DHE on when the table is going forward and off when each scan is completed. The potentiometer that records the position of the table revolves several times during one scan so that the output is a sawtooth, which must be rectified to a continuous function during analysis. The readings of the density potentiometer are continuous. The DHE supplies 4 v across each potentiometer, and the readings are digitized in the range 0 to 255 decimal.

When the DHE receives the signal to start, it digitizes the readings of the position and density potentiometers 10 times a second and stores the values in its memory unit. When the signal to stop is received, the information is written onto 9-track magnetic tape. Each scan therefore results in one record on the 9-track tape. The beginning of each record contains header data, which can be set by thumb wheels on the DHE.

#### 3.4 Circuit for DHE Switch on Automatic Drive

The connection to the DHE for starting and stopping a record consists of wires #1, 2, and 3. Wire #1 is common. When #1 is connected to #2, the DHE is on. When #1 is connected to #3, the DHE is off. Owing to the speed with which the DHE operates, ordinary switches and relays were found to be unsuitable because the contacts bounced. Therefore, a mercury-wetted relay was added to the automatic drive for controlling the DHE.

The K2 relay in the automatic drive operates only when the table is being driven forward in the automatic mode. The coil of the K2 relay operates on 25 v AC. Some of the current operating the K2 relay is rectified to operate the DHE relay by the circuit shown in Figure 1. The time constant of the rectifier circuit is

$$\tau = RC = 1.1 \times 10^4 \times 5 \times 10^{-6} = 5.5 \times 10^{-2} = 0.055 \text{ sec} \quad .$$

The time constant is greater than 1/60 sec for one cycle of the AC supply voltage and shorter than 1/10 sec between the points digitized by the

DHE. However, because of the delay in turning off the DHE, it is possible for one point to be taken after the scan is completed and the table starts to reverse.

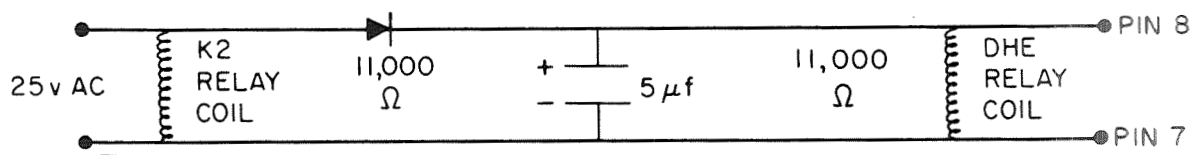

Figure 1. Rectifier circuit for DHE relay.

To be able to operate the microdensitometer without having the data recorded by the DHE, a DPDT toggle switch (the DHE switch on the automatic drive) is used to override the DHE relay. The circuitry is shown in Figure 2.

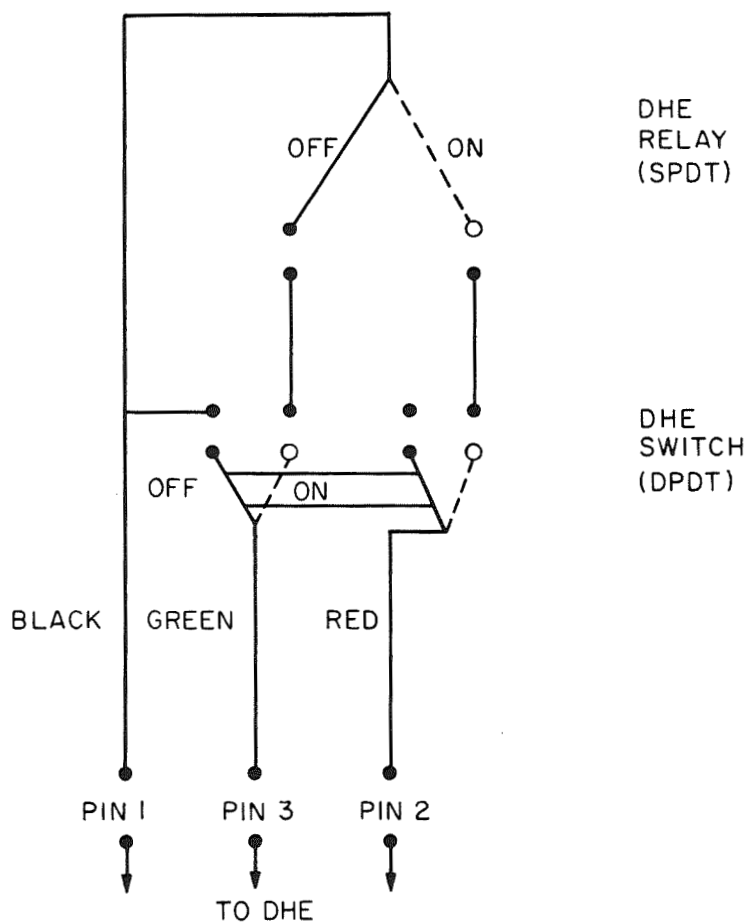

Figure 2. Circuit for controlling DHE in automatic drive.

### 3.5 Operating Instructions

#### 3.5.1 Microdensitometer and automatic drive

Since the manuals for these instruments describe in detail the operation of the machines, there is no need to repeat everything here. Briefly, the steps are the following:

1. Turn on power switch on automatic drive.
2. On microdensitometer, turn on POWER, LAMP, and PEN. If pen goes off scale when machine warms up, try turning the SYNC switch.
3. Place sample on specimen table.
4. Check focus and alignment of sample beam.
5. Select lever ratio by moving pivot to proper hole.
6. With switches on automatic drive, select desired number of steps between scans.
7. Leave direction switch in REVERSE for automatic operation.
8. If aperture must be changed, turn pen off during change.
9. Zero the pen so that it is a little above the minimum when film fog is read.
10. Set header thumbwheels on DHE.
11. Run the machine through a few scans without the DHE switch on to see that everything is operating properly.
12. Check that the stepper is engaged to move the counter.
13. Turn the step counter to zero, approaching zero from the negative direction.
14. When ready to take data, turn DHE switch on automatic drive to ON. The DHE will start taking data only when the DHE switch is ON and the table is moving forward in the automatic mode. When the table reverses, a relay will turn the DHE off even though the DHE switch is ON. When the table goes forward again, the relay will turn the DHE on for the next record.

15. Turn switch to automatic on automatic drive.
16. When the desired sample area has been scanned, turn the switch from automatic to manual on the automatic drive. This should be done during the reverse cycle after the stepper has operated.
17. Turn DHE switch OFF on automatic drive.
18. If another sample is to be scanned, repeat whatever steps are necessary.
19. To turn machine off, turn off PEN, LAMP, and POWER switches on microdensitometer and POWER switch on automatic drive.

### 3.5.2 DHE

The DHE equipment consists of four bays. Only the two bays on the right (bays 3 and 4) are used in the microdensitometer mode. Bay 4 is the 9-track tape-drive unit. Bay 3 contains the control panel, the analog-to-digital converter, and the central memory. The steps in the operation of the DHE are given below.

#### START PROCEDURE

1. Check that DHE switch on automatic drive is OFF.
2. Turn on circuit breakers.
3. Turn power switch ON (bottom of bay 3).
4. Turn power switch ON (bottom rear of bay 4). Check that the internal connector cables are attached.
5. Turn power ON (top front of bay 4).
6. Turn power ON (top front of bay 3).

NOTE: Indicator light is out. Press button only once.

7. Press MASTER RESET (bay 3).
8. Turn on memory power (switch labeled FABRI TEK, POWER CONTROL on bottom of bay 3).

9. Press MASTER RESET again.
  10. Press MICRODENS button (bay 3).
  11. Open tape-drive window.
  12. Check that the density is HIGH and tape speed LOW.
  13. Clean tape heads. Check for shredded tape indicating a malfunction of the tape drive.
    - A. Use Q-tips soaked in alcohol for metal parts.
    - B. Use FREON spray for rubber parts.
  14. Insert ring in tape.
  15. Load tape on right reel. Make sure tape is on flat and tight. Thread tape and wrap around left wheel several times.
  16. Press TAPE LOAD switch to start vacuum, and then press TAPE LOAD again to turn off vacuum.
  17. As vacuum is dying down, turn wheels to let tape into both tape channels.
  18. Press TAPE LOAD three times to turn vacuum ON, OFF, and ON again so tape will be properly positioned in tape channels.
  19. Check again that tape is tight on right wheel and close tape-drive window. Hold latch on window until window is closed.
  20. Press LOCAL button on bay 4.
  21. Press FORWARD to run tape past load point. If tape stops at load point, press FORWARD again.
  22. Press STOP.
  23. Press REVERSE (not REWIND) to return tape to load point. The load point must always be approached from reverse.
  24. Press REMOTE on bay 4. The WRITE ENABLE button should light on bay 3 when REMOTE is pressed. If it does not, either there is no ring in the tape, or the system is not reset, or the tape is not at the load point.
- NOTE: The tape has a tendency to creep until the tape drive is warmed up.

25. Set header data, using thumb wheels on bay 3. The top row is characters 1, 3, 5, etc., and the bottom row is characters 2, 4, 6, etc.
26. Take data with microdensitometer.
27. Press END OF FILE button on bay 3 to write end of file mark on tape.

#### STOP PROCEDURE

1. Write end of file (if not done previously).
2. Press LOCAL on bay 4.
3. Press REWIND.
4. Open tape-drive window.
5. Press TAPE LOAD switch to turn off vacuum.
6. Remove tape.

NOTE: If second tape is to be written, go to step 14 of START PROCEDURE

7. Turn power off on top front of bay 4.
8. Close tape-drive window.
9. Turn power switch OFF on rear of bay 4.
10. Press MASTER RESET on bay 3.
11. Turn memory power OFF on bottom of bay 3 (labeled FABRI TEK).

NOTE: Power should never be turned off on bay 3 while memory switch is on, because the surge might damage the memory unit.

12. Press MASTER RESET again.
13. Turn power off on top front of bay 3.
14. Turn power OFF, bottom of bay 3.
15. Turn off relays.

#### ERROR LIGHTS – bay 3

1. PARITY ERROR. Try MASTER RESET and MICRODENS to clear the light.

2. BUFFER OVERFLOW. Try MASTER RESET and MICRODENS.
3. TAPE TIME ERROR. Does not matter in microdensitometer mode.

## 4. DATA PROCESSING

### 4.1 Format of Data on 9-Track Tape

Each byte on the 9-track tape consists of nine bits, one of which is a parity bit and eight of which are data. Each record contains header data and measurements. In the header information, the eight data bits represent two hexadecimal characters of four bits each. Table 1 gives the conversion between binary, decimal, and hexadecimal.

Table 1. Number conversion.

Decimal (base 10)	Binary (base 2)	Hexadecimal (base 16)
0	0000	0
1	0001	1
2	0010	2
3	0011	3
4	0100	4
5	0101	5
6	0110	6
7	0111	7
8	1000	8
9	1001	9
10	1010	A
11	1011	B
12	1100	C
13	1101	D
14	1110	E
15	1111	F

The first 24 hexadecimal digits of each record are the numbers dialed in on the thumb wheels. The thumb wheels go only from 0 to 9. The next 40 characters are filled in automatically by the DHE. Characters 25 and 26 are F and C. Characters 27 and 28 are the record number. If the record number goes past 99, character 26 is changed to D. Characters 29 through 32 are FF50 for microdensitometer records. Characters 33 to 40 are all F's. Characters 41 to 64 are not used in microdensitometer records and contain random garbage. This space is used for timing information on Telescope data.

The data start with character 65. It takes two characters (one byte) for each density reading and each position reading. Each pair of numbers is followed by a separator byte of all 1 bits (FF in hexadecimal). Each point therefore takes three bytes or six hexadecimal characters. The series "intensity, position, FF," is repeated throughout the rest of the record until all the points in one scan are used up. If any space is left in the record, it is filled with all 1 bits (FF). The DHE writes records of length 3160 bytes or 6320 characters.

Occasionally, the DHE repeats the 24 characters from 41 to 64 that contain garbage in microdensitometer records. In this case, the start of the data is recognized by the FF separator. The data in any case may begin with either the intensity, the position, or the FF separator.

The total number of points possible in one record is

$$\begin{array}{l} \text{MAX. NO.} \\ \text{of POINTS} \end{array} = \frac{6320-64}{6} = \frac{6256}{6} = 1042 \frac{2}{3} .$$

For Apollo films, the 24 thumb wheels have been used as follows:

<u>Character</u>	<u>Information</u>
1-2	Last two digits of Baker-Nunn station number.
3-7	The 5-digit film number.
8-10	Frame number.

11-12	Star number on diffuse frames, "00" on cloud or step-wedge frames.
13-14	Lever ratio.
15-16	Diameter in mm of scanning aperture with implied decimal point between the characters. For 0.33 mm, "03" is used.
17-18	Number of steps between scans. For Apollo films there are always 25 $\mu$ per step.
19-24	Date of microdensitometer run in the order MONTH, DAY, and last two digits of YEAR.

#### 4.2 Format of Data on 7-Track Tape

Each 9-track microdensitometer file is copied and stored on a 7-track tape by program READ9. The length of the 7-track records is 632 computer words (or more for the longer records occasionally written by the DHE). Each 60-bit computer word contains five 9-track bytes. The 60-bit word is divided into five 12-bit sections. The first three bits of each section are zeros and are not used. The last nine bits of each section are the parity bit and the eight data bits of one 9-track byte.

To save space on the 7-track tape, only the part of each buffer that actually contains data is copied onto the 7-track tape, thereby reducing the size of each record.

#### 4.3 Conversion from DHE Position Units to Distance on Film

The DHE digitizes a signal in the range -2 to +2 v to a number from 0 to 255 decimal. When the connection between the DHE and the microdensitometer was set up, the voltage across the potentiometers was adjusted to be not greater than 2 v. From the examination of many records written by the DHE, it appears that the largest position reading actually generated by the DHE is 254. Since the position potentiometer rotates several times in the course of one scan, it is necessary before the data are used to add 254 to the position reading whenever the potentiometer starts another turn. The start of a new turn is determined by the large decrease in the raw position values. The range of the recording

table in DHE units is about 2413, as determined by examination of the rectified DHE records. The range of the recording table on the microdensitometer is about 260.5 mm. Therefore, there are  $2413/260.5$  or 9.263 DHE units/mm on the recording table.

To convert distance on the recording table to distance on the sample, divide by the lever ratio.

Conversely, to convert distance in millimeters on the film to DHE units, multiply by the lever ratio and by 9.263, which is the number of DHE units per millimeter on the recording table.

#### 4.4 Interpolation Interval for Star and Cloud Frames

Since the DHE records are taken at 10 points per second and the table speed is not necessarily completely uniform, the points are not at strictly equal intervals. For convenience in analysis, the data are transformed to arrays of equally spaced points by interpolating at fixed intervals in the raw data. Diffused star data are interpolated so that the interval is the same as that of the diameter of the scanning circle and cloud data are interpolated at the same spacing as the interval between scans.

The interpolation interval for star data is determined as follows. The diameter in millimeters of the fixed-aperture disk is divided by the magnifying power of the lens ( $\times 10$ ) to obtain the scanning diameter on the film. This distance is multiplied by the lever ratio, which is 50 for all star images, and then by 9.263 to obtain the interpolation interval in DHE units.

The interpolation interval for clouds is determined from the number of steps between scans. The number of steps is multiplied by 0.025 mm/step to give the distance on the sample. Multiplying by the lever ratio gives the distance on the recording table. Multiplication by 9.263 gives the interpolation interval in DHE units.

For star images, 20 interpolated points are computed if the scanning aperture is 1.0 mm or greater; 40 if the aperture is 0.5 or 0.33 mm. If the record is not long enough for the desired number of points, zeros are filled in for the missing ones. All the processing programs ignore the zeros.

#### 4.5 Processing of Step-Wedge Measurements

When the step wedges are measured with the data being recorded by the DHE, the speed of the table is reduced so that more points will be taken. The extra points are for obtaining a better average of the density on each step. In addition, four or five scans are usually taken at the same stepping interval as the images being measured. The DHE can be set to digitize at 100 points/sec instead of the usual 10 points/sec. However, even at the maximum speed of the table, the DHE records about 127 points. At 100 points/sec, it would record 1270 points, which is greater than the 1042 points that will fit in one buffer.

The program averages the several points on each step for each of the 21 steps. Points close to the border between steps are excluded from the average. Step wedges are always measured starting at the densest end. The measurement begins a little before the wedge on film fog. The beginning of the wedge is detected by the large increase in the density values. The first step is usually longer than the 0.5-cm width of the steps on the step tablet. The reason for this is that the covering in which the step tablet is encased leaves a small border at the end of the step tablet. For the step-wedge data to be processed automatically, it is necessary to determine the extra width of the first step so that the dividing line between the steps is known. It might seem that the border between steps would be obvious by the change in density. In fact, because of the noise in the records, this is not a reliable method.

All points not closer than 1 mm to the edge of a step are averaged to determine the density of a step. All wedges are measured at a ratio of 2, so the steps are 1 cm wide on the recording table.

#### 4.6 Calculation of Relative Exposure from Step Wedge

In principle, the step-wedge images on Apollo films should provide a means of calibrating absolute exposure. In practice, however, this is difficult because of the effects of reciprocity failure. The customary step-wedge images are 0.1-sec exposures, whereas the cloud images are taken with exposure times up to 32 sec. Assuming that the shape of the D-log E curve is not too greatly affected by reciprocity failure, the step-wedge data can still be used to calculate relative exposure.

The opacity of each step on the wedge is a factor of  $\sqrt{2}$  greater than the preceding step. This corresponds to a difference in  $\log_{10} E$  of 0.15. The ratio of exposure between any two densities on a film is calculated as follows. Let  $D_A$  and  $D_B$  be the two densities on the film. Let  $D_n$ ,  $n = 1 \dots 21$ , be the densities of the steps on the step-wedge image in order of increasing density. The exposure of each step on the wedge is

$$E_n = C \times 10^{0.15 n} ,$$

where  $C$  is a constant.

For each density  $D_A$  and  $D_B$ , we can determine the corresponding interpolated step numbers  $S_A$  and  $S_B$  as follows. If  $D_A$  falls between  $D_i$  and  $D_{i+1}$ , then  $S_A$  is given by

$$S_A = i + \frac{D_A - D_i}{D_{i+1} - D_i} .$$

Similarly,  $S_B$  is given by

$$S_B = j + \frac{D_B - D_j}{D_{j+1} - D_j} ,$$

where  $D_B$  falls between  $D_j$  and  $D_{j+1}$ .

The exposures  $E_A$  and  $E_B$  corresponding to the densities  $D_A$  and  $D_B$  are

$$E_A = C \times 10^{0.15 S_A}$$

and

$$E_B = C \times 10^{0.15 S_B}$$

The ratio  $E_A/E_B$  is

$$\frac{E_A}{E_B} = 10^{0.15 (S_A - S_B)}$$

#### 4.7 Average Density of Sky Background

The densities  $D_i$  along the perimeter of the cloud are averaged to give the mean density  $\bar{D}$ , where

$$\bar{D} = \frac{\sum_{i=1}^N D_i}{N}$$

The scatter  $\sigma$  about the mean  $\bar{D}$  is given by

$$\sigma = \sqrt{\frac{\sum_{i=1}^N (D_i - \bar{D})^2}{N - 1}}$$

Whenever a density  $D_i$  has a residual  $(D_i - \bar{D})$  greater than  $2\sigma$ , that density  $D_i$  is eliminated from the average  $\bar{D}$  to preclude the biasing effect of point star images. Two points before and after are also eliminated on the assumption that the neighboring points are systematically high even though they may not have a residual greater than  $2\sigma$ . The value of  $\bar{D}$  is then recomputed without the points near star images.

#### 4.8 Total Radiance of Cloud or Star Images

The radiance measured on an Apollo cloud or diffused star image is the sum of the radiances of the sky background and the object. Let  $B(x, y)$  be the measured combined radiance and let  $B_{\text{sky}}$  be the radiance of the sky background, which is assumed to be essentially uniform over the image. The radiance due to the object is  $B(x, y) - B_{\text{sky}}$ . The integrated radiance  $I$  of an object is obtained by integrating  $B(x, y) - B_{\text{sky}}$  over the whole image. As an interim procedure, it is convenient to divide all radiances by  $B_{\text{sky}}$  and multiply the integrated results by  $B_{\text{sky}}$  after the absolute value of the radiance of the sky has been determined independently. The integrated radiance  $I$  can be calculated from

$$I = B_{\text{sky}} \int \frac{B(x, y) - B_{\text{sky}}}{B_{\text{sky}}} dx dy \quad . \quad (1)$$

Given a grid of radiance values  $B_{ij}$ , the value of  $I$  is approximately

$$I = B_{\text{sky}} \sum_{ij} \frac{B_{ij} - B_{\text{sky}}}{B_{\text{sky}}} \Delta x \Delta y \quad . \quad (2)$$

The radiances  $B_{ij}$  and  $B_{\text{sky}}$  are calculated from the corresponding exposures  $E_{ij}$  and  $E_{\text{sky}}$  by dividing the exposures by the exposure time  $\Delta t$ . Equation (2) then becomes

$$\begin{aligned} I &= B_{\text{sky}} \sum_{ij} \frac{(E_{ij}/\Delta t) - (E_{\text{sky}}/\Delta t)}{E_{\text{sky}}/\Delta t} \Delta x \Delta y \\ &= B_{\text{sky}} \sum_{ij} \frac{E_{ij} - E_{\text{sky}}}{E_{\text{sky}}} \Delta x \Delta y \quad . \quad (3) \end{aligned}$$

The exposure time  $\Delta t$  cancels out as a result of having divided all radiances by the radiance of the sky background. Equation (3) can be rewritten as

$$I = B_{\text{sky}} \sum_{ij} \left( \frac{E_{ij}}{E_{\text{sky}}} - 1 \right) \Delta x \Delta y \quad . \quad (4)$$

The quantities  $E_{ij}/E_{\text{sky}}$  can be determined from the step-wedge images as explained in Section 4.6.

If  $I$  is in units of zeroth-magnitude stars, then the magnitude  $m$  of the cloud or star image is

$$m = -2.5 \log_{10} I \quad . \quad (5)$$

#### 4.9 Radiance of Sky Background

The radiance  $B_{\text{sky}}$  of the sky background can be found by using measurements of diffused star images of known magnitude. Since the Apollo clouds shine by reflected sunlight, we should use calibration stars whose spectral type is as close as possible to that of the sun.

Equation (5) can be solved for  $I$ , in equivalent number of zeroth-magnitude stars,

$$I = 10^{-m/2.5} \quad . \quad (6)$$

Substituting  $I$  from equation (4) into equation (6), we get

$$B_{\text{sky}} \sum_{ij} \left( \frac{E_{ij}}{E_{\text{sky}}} - 1 \right) \Delta x \Delta y = 10^{-m/2.5} \quad . \quad (7)$$

Solving equation (7) for  $B_{\text{sky}}$ , we have

$$B_{\text{sky}} = \frac{10^{-m/2.5}}{\sum_{ij} \left[ (E_{ij}/E_{\text{sky}}) - 1 \right] \Delta x \Delta y} \quad (8)$$

If  $\Delta x$  and  $\Delta y$  are in degrees, then  $B_{\text{sky}}$  will be in zeroth-magnitude stars per square degree.

#### 4.10 Distance in Kilometers between Points on Cloud Image

The distance between the points on a cloud is calculated from the number of steps between each scan since the interpolation interval is the same as the distance between scans. Multiplying the number of steps between scans by 0.025 mm/step gives the interval in millimeters on the film. Dividing by the Baker-Nunn focal length of 493.6 mm gives the interval in radians.

The range to the cloud is given in megameters. Multiplying the interval in radians by the range in megameters times  $10^3$  gives the distance in kilometers between the points on the cloud.

#### 4.11 Format of Cloud Data Tape

The interpolated density values produced by program PLOT9 for cloud images are stored, one record per scan, on a 7-track tape. The beginning of each record contains header data that identify the record. The format of the records is given below:

<u>Word</u>	<u>Contents</u>
1	Station number (integer)
2	Film number (integer)
3	Frame number (integer)
4	Lever ratio (real)
5	Scanning diameter in mm (real)
6	Distance between scans in mm (real)

WordContents

7-9	Date of microdensitometer measurement
7	Month (integer)
8	Day (integer)
9	Last two digits of year (integer)
10	Number of points (integer)
11	Record number (integer)
12-END	Density array (real)

## 5. ANALYSIS

### 5.1 Symmetry Axes of Cloud

Given a matrix of intensities  $E(x_i, y_j)$  of a cloud where the rows and columns are equally spaced, the  $x_{cm}$  and  $y_{cm}$  values of the centroid of the cloud are

$$x_{cm} = \frac{\sum_{ij} x_i E(x_i, y_j)}{\sum_{ij} E(x_i, y_j)},$$

and

$$y_{cm} = \frac{\sum_{ij} y_j E(x_i, y_j)}{\sum_{ij} E(x_i, y_j)}.$$

The moment tensor I is

$$I = \begin{pmatrix} I_{xx} & I_{xy} \\ I_{yx} & I_{yy} \end{pmatrix},$$

where

$$I_{xx} = \sum_{ij} E(x_i, y_j) (y_i - y_{cm})^2,$$

$$I_{yy} = \sum_{ij} E(x_i, y_j) (x_i - x_{cm})^2 ,$$

$$I_{xy} = I_{yx} = - \sum_{ij} E(x_i, y_j) (x_i - x_{cm}) (y_i - y_{cm}) .$$

The eigenvalues of I are computed from the equation

$$\begin{vmatrix} I_{xx} - \lambda & I_{xy} \\ I_{yx} & I_{yy} - \lambda \end{vmatrix} = 0 ,$$

which gives

$$(I_{xx} - \lambda) (I_{yy} - \lambda) - I_{xy} I_{yx} = 0$$

$$I_{xx} I_{yy} - \lambda (I_{xx} + I_{yy}) + \lambda^2 - I_{xy} I_{yx} = 0 ,$$

which can be written

$$A\lambda^2 + B\lambda + C = 0 ,$$

where

$$A = 1$$

$$B = -(I_{xx} + I_{yy})$$

$$C = I_{xx} I_{yy} - I_{xy} I_{yx} .$$

The solution for  $\lambda$  is

$$\lambda_{\pm} = \frac{-B \pm \sqrt{B^2 - 4AC}}{2A} .$$

Using either of the two equations given in the matrix equation

$$\begin{pmatrix} I_{xx} - \lambda_{\pm} & I_{xy} \\ I_{yx} & I_{yy} - \lambda_{\pm} \end{pmatrix} \begin{pmatrix} x \\ y \end{pmatrix} = 0 \quad ,$$

We can solve for y as a function of x to obtain the lines defining the eigenvectors of the moment tensor. Using the first equation, we have

$$(I_{xx} - \lambda_{\pm})x + I_{xy} y = 0$$

or

$$y = \frac{\lambda_{\pm} - I_{xx}}{I_{xy}} x \equiv m_{\pm} x \quad ,$$

where

$$m_{\pm} = \frac{\lambda_{\pm} - I_{xx}}{I_{xy}} \quad .$$

## 5.2 Plotting Symmetry Axes

We wish to plot the intensity of a cloud image along a line passing through the origin of coordinates with slope  $m_{\pm}$ . From the triangle below we see that the sine and cosine of the angle  $\theta$  between the symmetry axis and the x axis are

$$\sin \theta = \frac{m_{\pm}}{\sqrt{1 + m_{\pm}^2}} \quad ,$$

$$\cos \theta = \frac{1}{\sqrt{1 + m_{\pm}^2}} \quad ,$$

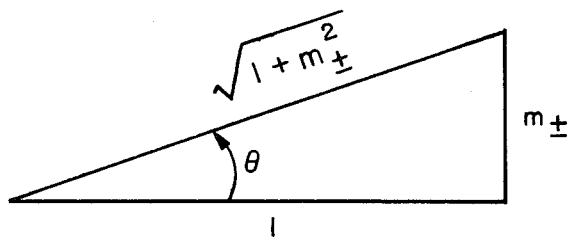

If we start at the origin and plot points at unit distance from each other along the line, the x and y coordinates of each point to be plotted are

$$x_n = n \cos \theta$$

$$y_n = n \sin \theta \quad .$$

If the intensity of the cloud is given as a matrix of numbers  $E(x_i, y_j)$  and the point  $(x_n, y_n)$  falls between the four grid points

$$\begin{matrix} E(x_i, y_j) & E(x_i, y_{j+1}) \\ E(x_{i+1}, y_j) & E(x_{i+1}, y_{j+1}) \end{matrix} \quad ,$$

the interpolated value  $E(x_n, y_n)$  can be obtained by interpolating first in x and then in y (or vice versa). We get

$$E(x_n, y_j) = E(x_i, y_j) + \frac{x_n - x_i}{x_{i+1} - x_i} \left[ E(x_{i+1}, y_j) - E(x_i, y_j) \right]$$

and

$$E(x_n, y_{j+1}) = E(x_i, y_{j+1}) + \frac{x_n - x_i}{x_{i+1} - x_i} \left[ E(x_{i+1}, y_{j+1}) - E(x_i, y_{j+1}) \right] \quad ,$$

from which

$$E(x_n, y_n) = E(x_n, y_j) + \frac{y_n - y_j}{y_{j+1} - y_j} \left[ E(x_n, y_{j+1}) - E(x_n, y_j) \right] \quad .$$

## 6. REFERENCES

BUFFALANO, C.

1971. A physical model of the Apollo oxygen releases. *Journ. Geophys. Res.*, vol. 76, pp. 27-35.

LUNDQUIST, C. A.

1970. Photometry from Apollo tracking. In Space Research X, ed. by T. M. Donahue, P. A. Smith, and L. Thomas, North-Holland Publ. Co., Amsterdam, pp. 25-32.

SHARMA, R. D., and BUFFALANO, C.

1971. Temperature and size histories of liquid  $H_2$ ,  $O_2$  and  $H_2O$  particles released in space. *Journ. Geophys. Res.*, vol. 76, pp. 232-237.

SHARMA, R. D., KRATAGE, M. L., and BUFFALANO, A. C.

1971. An analysis of the dynamics and thermodynamics of water and oxygen particles in space based on photographs taken from the ground during Apollo missions. Presented at AIAA 6th Thermophysics Conference, Tullahoma, Tenn., April 26-28, AIAA Paper No. 71-474.

SOUTHWORTH, R. B.

1966. Observations of integrated brightness. An opportunity for comet observations. *Mem. Soc. Roy. Sci. Liège*, vol. 12, pp. 247-254.