

## **General Disclaimer**

### **One or more of the Following Statements may affect this Document**

- This document has been reproduced from the best copy furnished by the organizational source. It is being released in the interest of making available as much information as possible.
- This document may contain data, which exceeds the sheet parameters. It was furnished in this condition by the organizational source and is the best copy available.
- This document may contain tone-on-tone or color graphs, charts and/or pictures, which have been reproduced in black and white.
- This document is paginated as submitted by the original source.
- Portions of this document are not fully legible due to the historical nature of some of the material. However, it is the best reproduction available from the original submission.

Report WTA-3319

MOTOR DRIVERS FOR DC BRUSHLESS MOTORS

George L. Ward and David Nafus  
Washington Technological Associates, Inc.  
979 Rollins Avenue  
Rockville, Maryland 20852

July 1971

FINAL REPORT

Prepared for

GODDARD SPACE FLIGHT CENTER  
Greenbelt, Maryland 20771



FACILITY FORM 602

N71-34203

(ACCESSION NUMBER)

28

(PAGES)

Q-121498

(NASA CR OR TMX OR AD NUMBER)

(THRU)

03

(CODE)

09

(CATEGORY)

1. Report No. WTA 3319	2. Government Accession No.	3. Recipient's Catalog No.	
4. Title and Subtitle  Motor Drivers for DC Brushless Motors		5. Report Date July 1971	
		6. Performing Organization Code	
7. Author(s) George L. Ward and David Natus		8. Performing Organization Report No. WTA 3319	
9. Performing Organization Name and Address Washington Technological Associates, Inc. 979 Rollins Avenue Rockville, Maryland 20852		10. Work Unit No.	
		11. Contract or Grant No. NAS 5-21166	
12. Sponsoring Agency Name and Address Goddard Space Flight Center Greenbelt, Maryland 20771  C. deKramer, Code 723		13. Type of Report and Period Covered  FINAL REPORT	
		14. Sponsoring Agency Code Code 723	
15. Supplementary Notes			
16. Abstract  The purpose of this program was the design and the manufacture of drivers for DC brushless motors. The circuits were packaed in hybrid form and capable of driving motors to 20 amps.  A low power driver for driving motors to 0.375 amps was designed, fabricated, tested and delivered. This consisted of six controlled switches and a control amp in a one-by-one inch flatpack.  A high power driver controlled by the low power driver for driving motors to 20 amps was designed, fabricated, tested and delivered. This operates in either an analog or switching mode as desired.			
17. Key Words		18. Distribution Statement	
19. Security Classif. (of this report) Unclassified	20. Security Classif. (of this page) Unclassified	21. No. of Pages  22	22. Price

## TABLE OF CONTENTS

		Page No.
	LIST OF ILLUSTRATIONS	i
	LIST OF TABLES	ii
	PREFACE	iii
1.0	MOTOR DRIVER SYSTEM	1
1.1	LOW POWER DRIVER	1
1.1.1	Initial Design	1
1.1.2	Device Selection	4
1.1.3	Power Considerations	6
1.1.4	Breadboard Changes	8
1.1.5	Packaging Design	8
1.1.6	Hybrid Prototype	11
1.2	HIGH POWER DRIVER	11
1.2.1	Initial Design	11
1.2.2	Device Selection	13
1.2.3	Breadboard Results	15
1.2.4	Packaging Design	15
1.2.5	Hybrid Prototype	16
1.2.6	Final Design	16
1.3	OPERATIONAL NOTES	16
1.3.1	Low Power Driver	16
1.3.2	High Power Driver	18

## LIST OF ILLUSTRATIONS

<u>Figure No.</u>		<u>Page No.</u>
1	Driver System	2
2	Initial Design Driver Switches	3
3	Output Drivers	4
4	Initial Control AMP Design	5
5	Direct Drive Lower Driver	7
6	Control "and" Gate	7
7	Bode Plot	9
8	Control AMP - Final Design	10
9	Output Driver Stage	12
10	Switching Regulator	12
11	OR Gate	14
12	High Power Driver Connection	17
13	Low Power Driver	19
14	High Power Driver	20
15	Photo of Low Power Driver	21
16	Photo of High Power Driver	22

## LIST OF TABLES

Table No.

Page No.

1

Motor Driver Specifications

1

2

Transistor Specifications

6

3

Power Transistor Specifications

14

## PREFACE

The objective of this task was to design, fabricate, and test motor drivers for three-phase delta wound DC motors. Design goals for the three types of drivers were 375 MA (low power driver), 2.5 amps (medium power driver), and 20 amps (high power driver).

The six individual drivers (three upper and three lower) were to be switched on or off by six separate digital control signals. Analog control signals determine the current level of each upper driver.

Adequate power dissipation was to be a primary concern in the package design.

A driver was designed to provide 2.5 amps or 20 amps to satisfy the requirements for the 2.5 amp and 20 amp drivers.

The low power drivers (6 each) and a control amplifier were packaged in a one-inch square flat pack.

The high power driver is driven by the low power driver. The analog mode is used for 2.5 amps, and the switching mode for 20 amps. Three high power drivers are packaged in a single package which is mounted on a heatsink.

## 1.0 MOTOR DRIVER SYSTEM

A DC brushless motor shown in Figure 1 functions by electronically directing current into the proper windings to eliminate the need for mechanical brushes.

A series of lamps and photocells arranged in the motor provides commands to a motor-driver package which then directs current into the proper motor windings. The driver package also contains a control amp to control the current level through the motor. The system packaged in hybrid flatpacks includes the control amp and driver circuits.

### 1.1 LOW POWER DRIVER

#### 1.1.1 Initial Design

The initial objective was to design a circuit to drive the motor reliability and to fulfill the specifications shown in Table 1. All components selected had to be available in chip-form for integration into the hybrid package.

Supply Voltage:	24 to 32 volts
Analog Control Input Voltage:	0 to 5 volts, 1 ma maximum
Maximum Voltage Drop at Saturation:	10% of supply voltage
Maximum Current Drain:	2.5% of maximum current

Table 1. MOTOR DRIVER SPECIFICATIONS

The initial design for the drivers is shown in Figure 2. The selection of a particular driver switch (upper and lower) is controlled by the decoder. The upper driver also has a control amp input. This controls the motor current by linearly controlling the on-state of the upper driver. The lower driver is either on or off with no in between states.

The circuit shown is a basic DTL type of logic operating from 28V. The output stages are Darlington circuits.

Typically, NPN power transistors have higher beta and lower saturation voltage than PNP devices when operating at high collector current levels. Thus, for the output stage, NPN transistors are used. The motor-driver specification requires that the maximum voltage drop across the driver at saturation be 10% of the supply voltage. Therefore, the maximum drop across each switch (upper or lower) is 1.4 volts with a 28 volt supply.

For a driver stage as shown in Figure 3, the drop consists of  $V_{ce}$  of Q1 and  $V_{be}$  of Q2. The choice of the type of stage (PNP-NPN or NPN-NPN) depends upon the source of the drive (positive or negative).

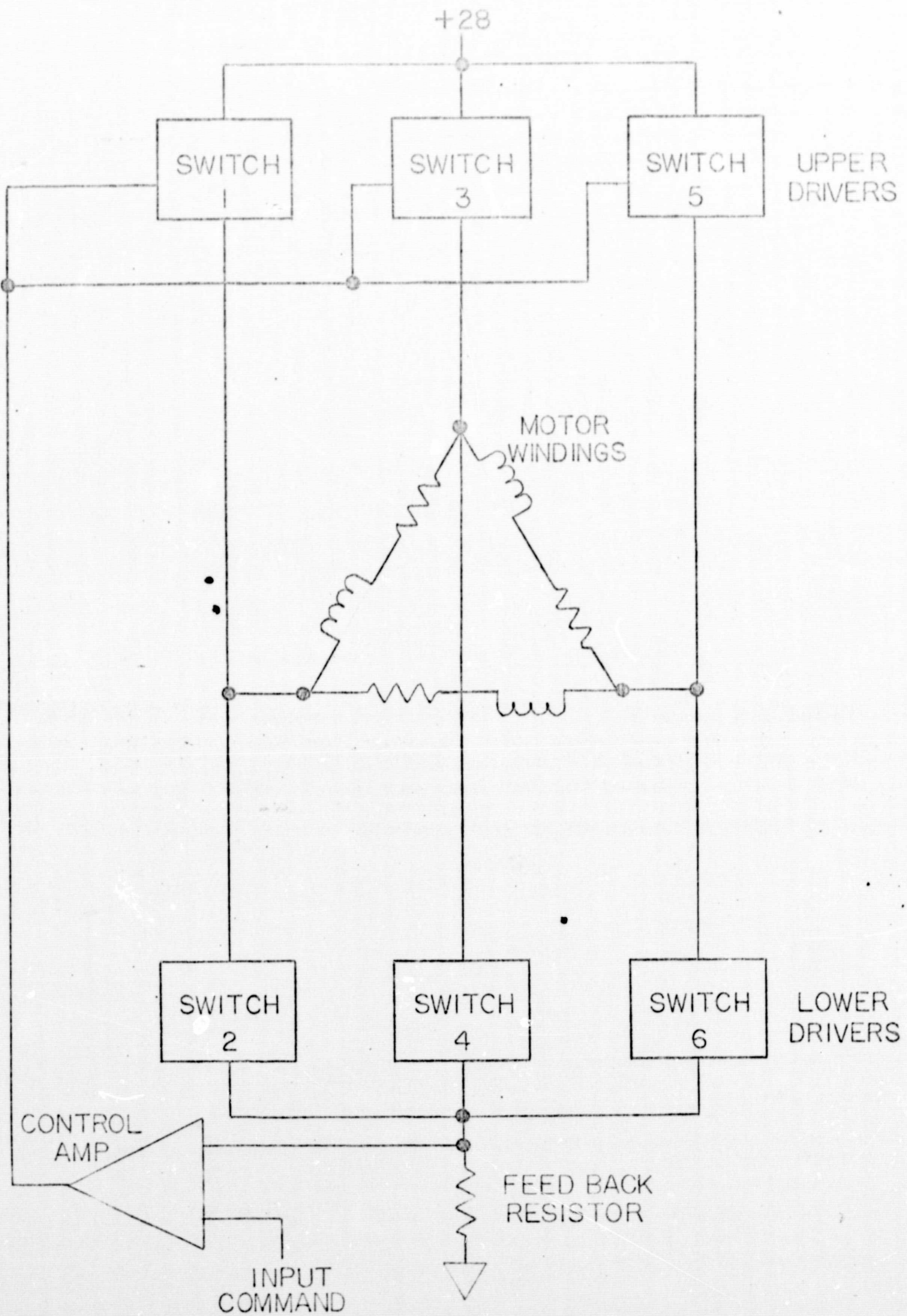

FIGURE 1. DRIVER SYSTEM

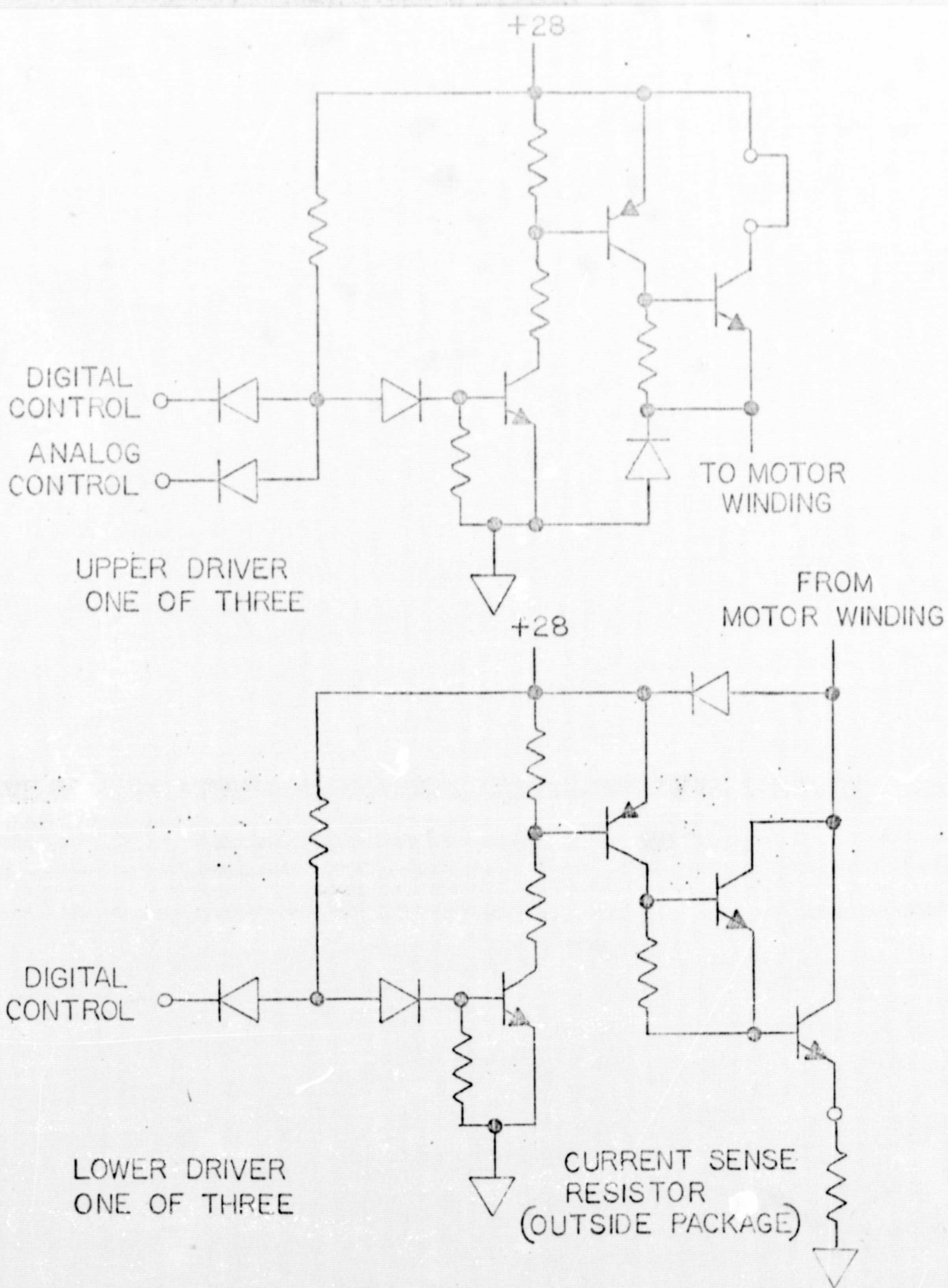

FIGURE 2. INITIAL DESIGN DRIVER SWITCHES

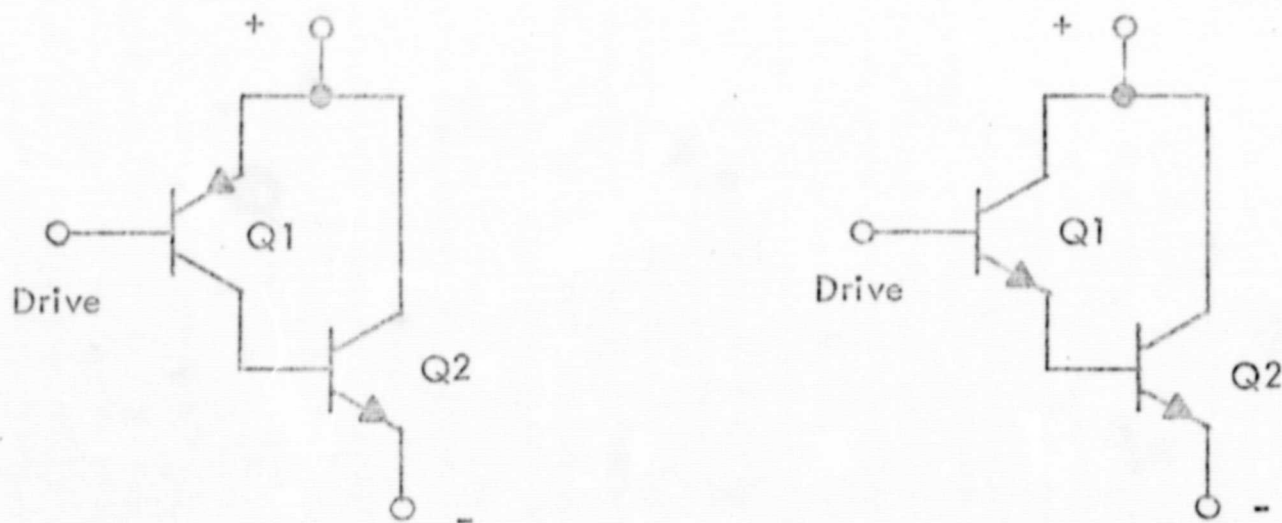

Figure 3. OUTPUT DRIVERS

The power dissipation of the output transistor is about 2.6 watts (maximum power dissipation occurs at half-power point and is equal to 14 volts x 187.5 milliamps). This must be allowed for in the package design.

The initial control amp design is shown in Figure 4. Since it is desired to operate the motor driver package from 28V only, the control amp will have to take the low level feedback signal (200 mv maximum) and transform it to a higher voltage. The control voltage is attenuated from five volts maximum to 200 mv, maximum which equals the feedback voltage, as it felt that greater temperature stability can be obtained by matching the control input voltage to the feedback voltage before transforming to a higher voltage. This is shifted with zeners to a higher level. The output of the differential pair is amplified by a single transistor and sent to the upper drivers.

### 1.1.2 Device Selection

All transistors must have high beta and fast switching speeds at rated currents for optimum efficiency. Units selected must be available both in chip and cased form.

For the output driver, which must be able to pass 0.375 amps, the Solitron SDT5002 was selected. This unit has a beta which is greater than fifty from 1ma to over one amp and has excellent reverse leakage characteristics.

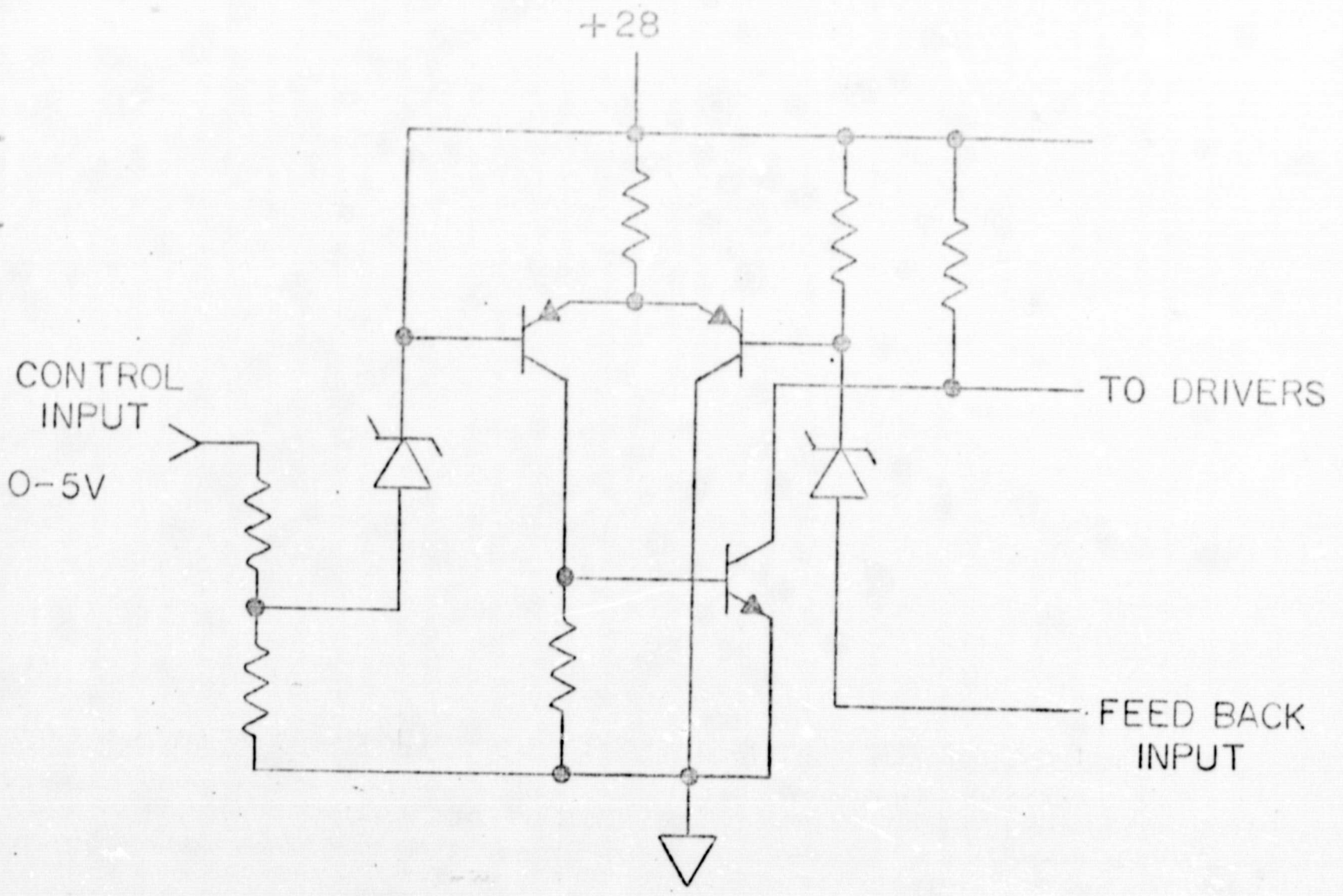

FIGURE 4. INITIAL CONTROL AMP DESIGN

For the drivers, Motorola 2N4401 and 2N4403 transistors were chosen. These are high beta, medium speed switching transistors.

	$\beta$	Current Capacity	Saturation Voltage
Output Transistor	20 <sup>1</sup>	0.375A <sup>1</sup>	V <sub>ce</sub>
SDT 5002	50 min <sup>2</sup>	2A <sup>2</sup>	1.2 max
Driver Transistor, PNP	20 <sup>1</sup>	0.01A <sup>1</sup>	V <sub>be</sub>
2N4403	100 min <sup>2</sup>	0.6A <sup>2</sup>	0.4 max
Driver Transistor, NPN	20 <sup>1</sup>	0.1A <sup>1</sup>	
2N4401	100 min <sup>2</sup>	0.6A <sup>2</sup>	0.4 max

- 1 - Circuit Requirement
- 2 - Manufacturer's Specification

Table 2. TRANSISTOR SPECIFICATIONS

The combined saturation voltage exceeds the specification of 1.4V (1.2 + 0.4 = 1.6V). Tests indicated that we could expect a voltage drop of less than one volt total using this driver-output combination at 0.375 amp (all units manufactured were about one volt).

### 1.1.3 Power Considerations

A calculation of the power consumption for the initial design indicated a need for improvement. The power calculation showed a requirement of 12 ma from the +28 volt supply. This is approximately 3.25% of the total delivered power and is above the specification of 2.5%.

The lower driver circuit (Figure 5) can be driven directly from the DTL drivers, eliminating a large number of components and decreasing power consumption. The typical beta of the drive transistors is high enough to assure adequate drive from a typical DTL stage with a 6K ohm pull-up resistor. This type of driver can be driven from TTL logic by putting a current limiting resistor in series with the input.

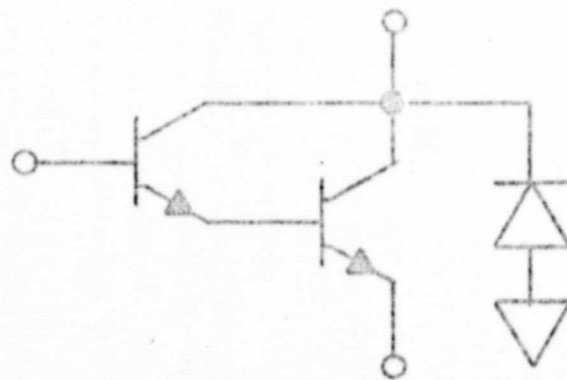

Figure 5. DIRECT DRIVE LOWER DRIVER

The upper drivers (Figure 6) can be simplified by driving the input transistor directly from the logic and controlling the current at the emitter. The transistor base-emitter breakdown is greater than six volts and will not break down if the maximum voltage is limited. This is accomplished by clamping the supply voltage with a five-volt zener.

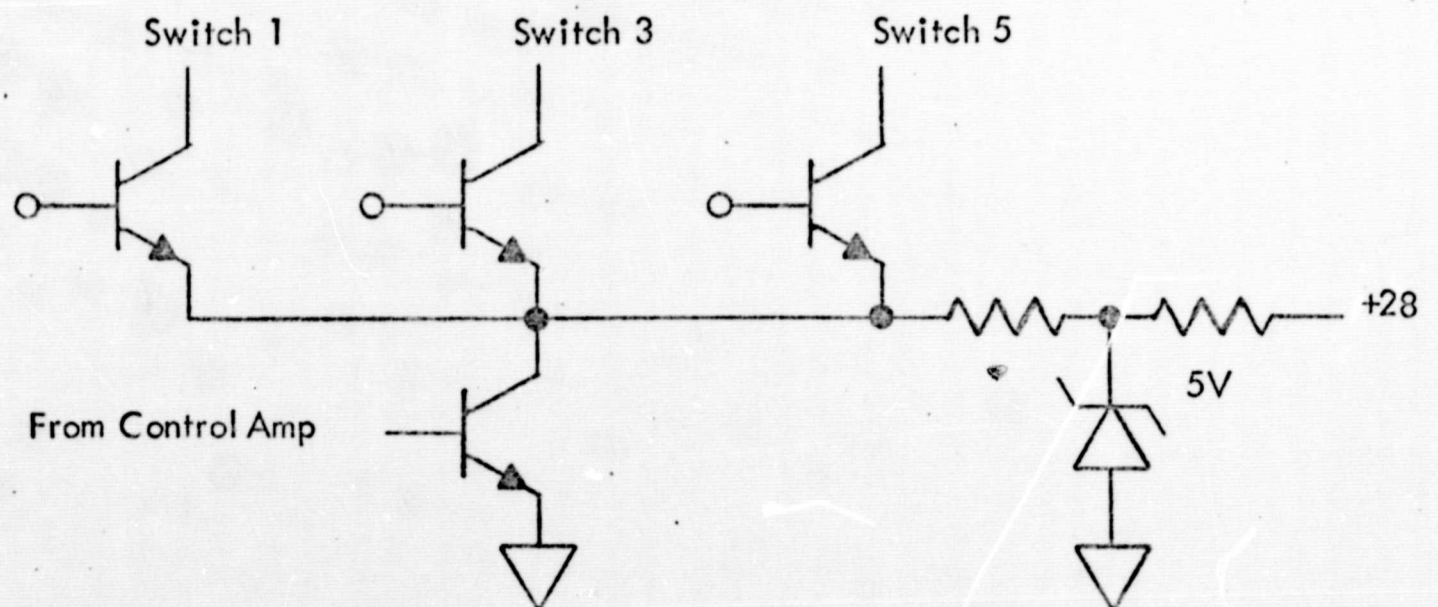

Figure 6. CONTROL "AND" GATE

The power consumption now is approximately 3.5 ma which is less than 1% of the maximum (375 ma) and is well within the 2.5% specification.

#### 1.1.4 Breadboard Changes

In the amplifier, the zener diodes were replaced with resistors before breadboarding as it would have been difficult to obtain the type of matching needed with zener diodes. Also, a zener regulated supply was added allowing the amplifier some isolation from noise on the 28V line.

The breadboard was then built and tested. A bode-plot was made and proper compensation was added. To assure stability, the open loop gain should roll-off at 6db/octave (20db/decade) to unity gain. Sufficient compensation was added to assure stability for any unit (allows wide parameter drift or different circuit placement/wiring changes without recompensation).

Results of the breadboard test were satisfactory except for temperature drift. To improve thermal stability, a second differential stage was added to the amplifier. The new operational amplifier schematic is shown in Figure 8. The bode plot for this is shown in Figure 7.

#### 1.1.5 Packaging Design

The 0.375 amp driver is packaged in a one-inch square flatpack. A photograph of the final layout is shown in Figure 15.

The control amp is placed off to the side to isolate it from the heat generated by the power transistors.

To assure good thermal conductivity from the driver transistors to the case, the transistors were mounted to the substrate with a silicon-gold eutectic bond and the substrate was mounted to the case with conductive epoxy.

The calculated thermal resistance of the high power transistors from junction to case is as follows:

Chip	6°C/W
Bond	.5°C/W
Substrate	8°C/W
Bond	3°C/W
Case	8°C/W
	<hr/>
Total	25.5°C/W

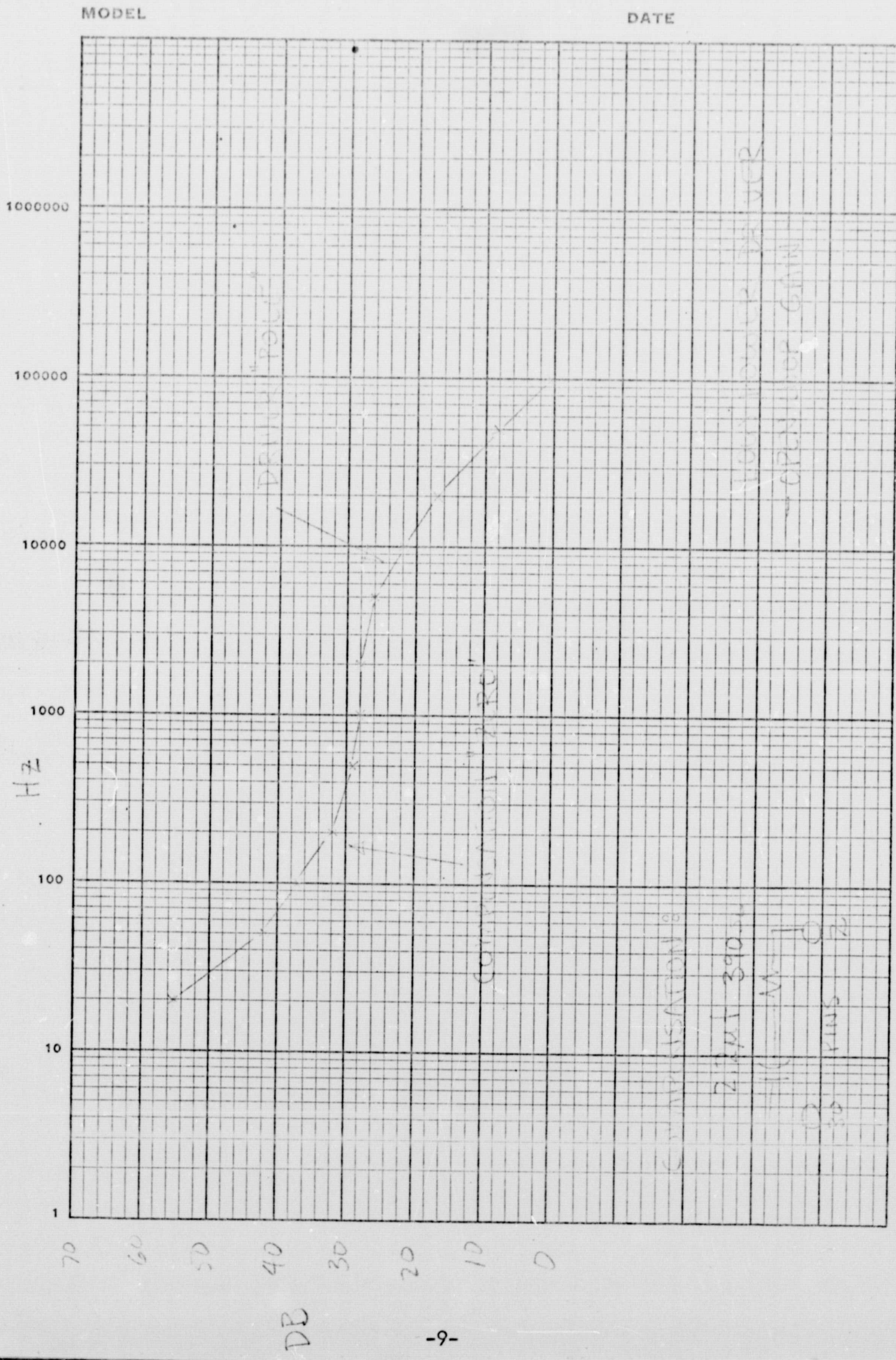

Figure 7. BODE PLOT

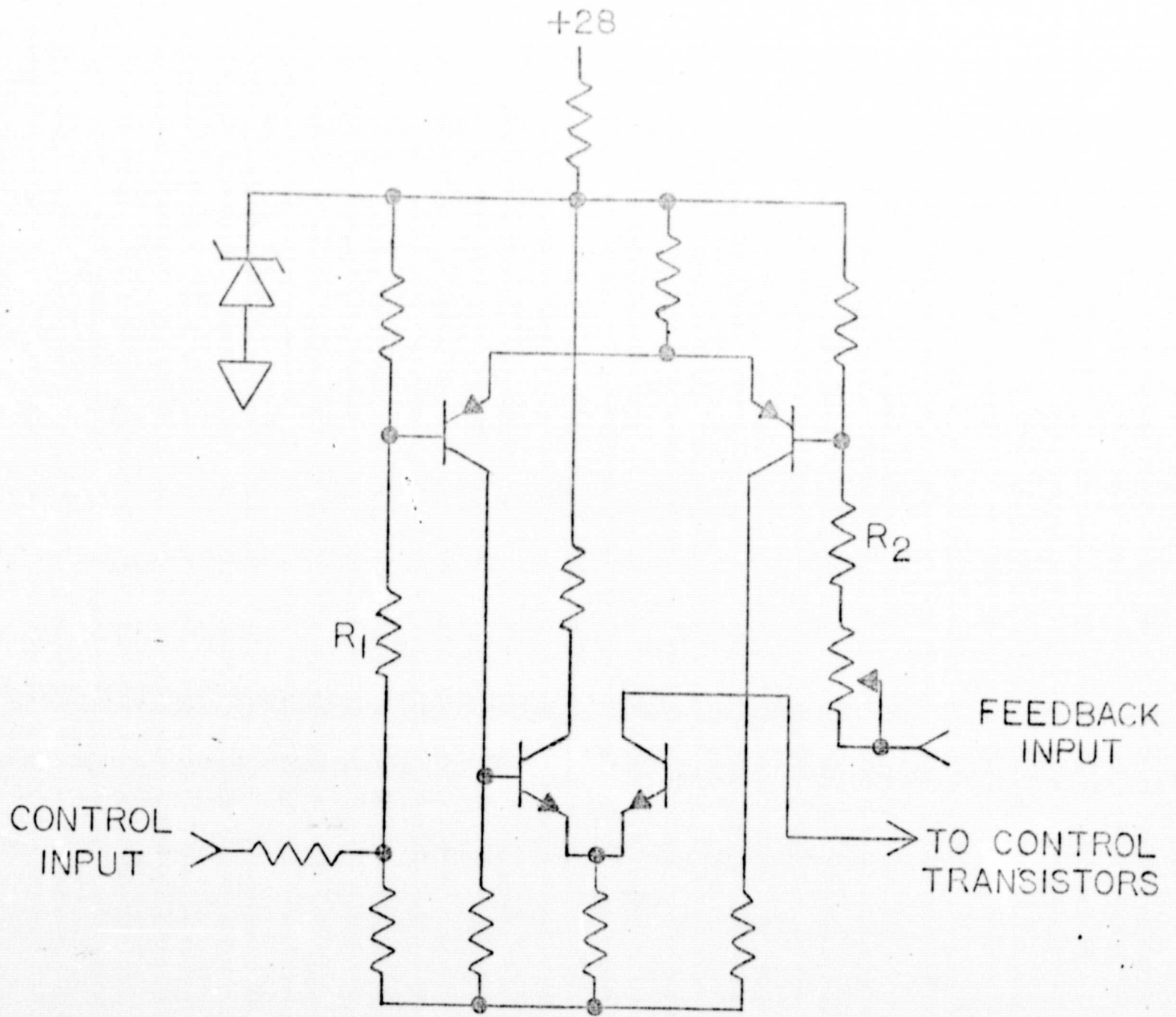

FIGURE 8. CONTROL AMPLIFIER - FINAL DESIGN

Allowing a 200°C maximum junction temperature and a 85°C heatsink temperature with full dissipation of 2.6W, the maximum allowable case to heatsink thermal resistance will be:

$$R = \frac{200 - 85 - 25.5 \times 2.6}{2.6} = 18.7^\circ\text{C/W}$$

### 1.1.6 Hybrid Prototype

A prototype unit was assembled and tested. To mount the flatpack, a hole was cut in the carrier and a fan forced air around the flatpack for cooling. Operation of the flatpack was satisfactory except for thermal drift. Heat transmitted through the flatpack from the output drivers to the control amp was causing a definite shift in the operating point. At two-volt command the driver would start at 150ma and drift to ~ 130ma as the heat built up. By turning on drivers further away from the control amp on the substrate, the effect was reduced.

A metal block with a heatsink attached was designed to improve heat dissipation. The flatpack was mounted to the block with a coating of heatsink compound in between. This reduced the effect of heat spreading by a large amount (from ~ 20ma to 5ma).

Additional improvement was made by moving resistors, R1 and R2 (see Figure 8), outside the package. Low temperature coefficient resistors were used and the results were now excellent. The effect of the heat generated in the output transistors on the control amplifier was minimum.

Several units were built and tested. During thermal cycling, an objectionable amount of drift was detected that had not existed in the first prototype. Further tests revealed that R3 and R4 were not tracking over temperature and the degree of tracking between resistors varied from package to package. A silicon resistor was installed in the unit. This resistor has two identical resistors on the same chip which have matched temperature coefficients. The addition of this resistor reduced the drift to an acceptable level. The final electrical diagram is shown in Figure 13.

## 1.2 HIGH POWER DRIVER

### 1.2.1 Initial Design

The high power driver must be capable of delivering twenty amps to a load with a saturation voltage of 1.4 volts maximum. The switching times must also be short to provide high efficiency. The input impedance of the high power driver must be such that the 0.375 amp driver is capable of driving it.

A search of available high power transistors showed that NPN devices had better specifications (higher B, lower saturation), therefore, drivers of the type shown in Figure 9 will be used. It is suitable for both the upper and lower drivers and can be driven

directly from the 0.375 package. By using a transistor that has a constant beta from low to high currents, the high power driver can be used for the medium power package. Both the medium power driver and the high power driver must be capable of dissipating a large amount of heat. Thus, the medium power driver would be similar to the high and we can avoid unnecessary duplication by allowing the output driver to operate in an analog mode up to 2.5 amps and in a switching mode thereafter (switching can also be used below 2.5 amp if desired).

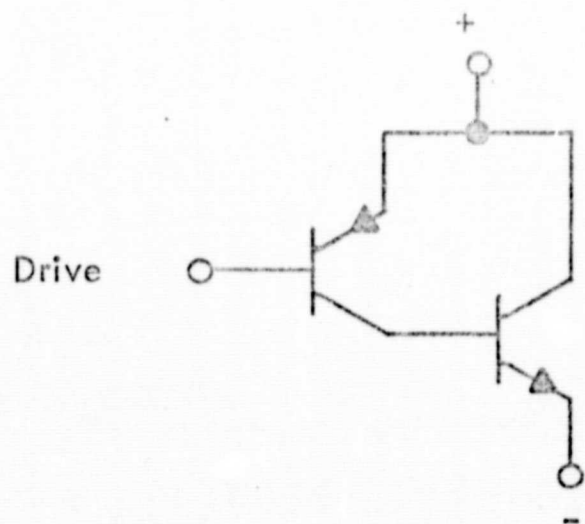

Figure 9. OUTPUT DRIVER STAGE

The block diagram for switching operations is shown in Figure 10. This is a fairly standard type of switching regulation. The inductance of the motor windings is used as the energy storage device.

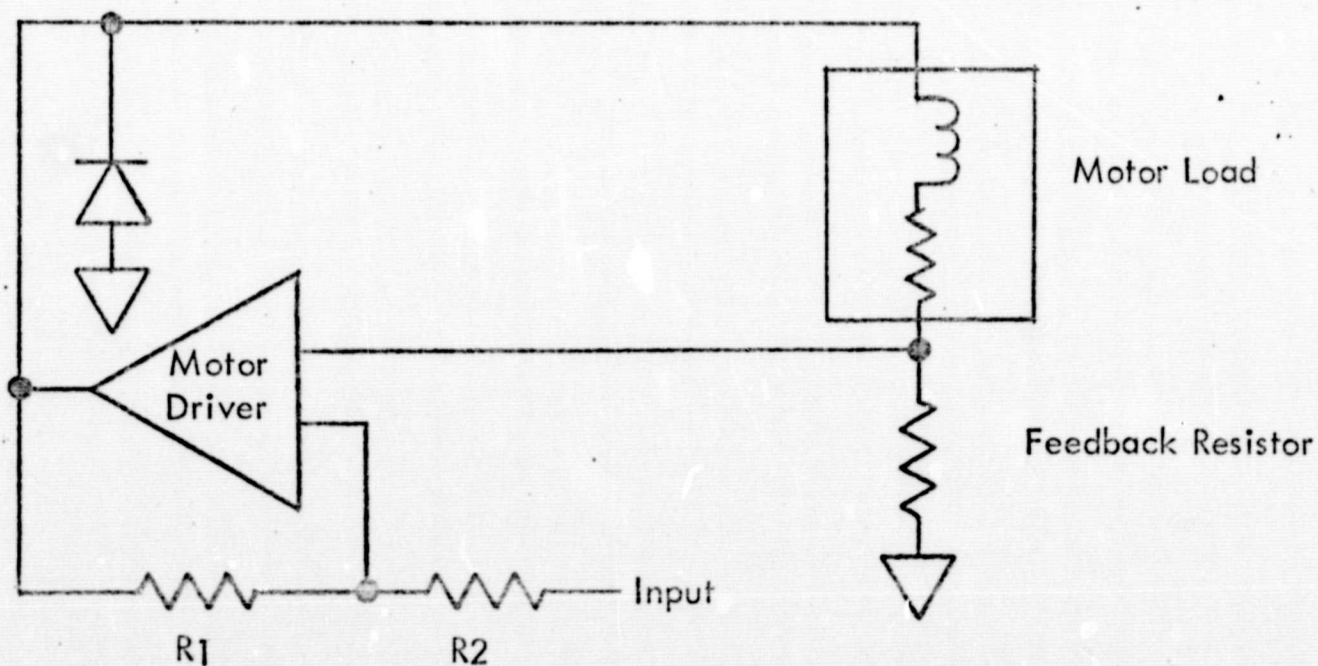

Figure 10. SWITCHING REGULATOR

In operation, starting from zero with a control input, the motor driver will saturate and supply 28V to the motor. The current through the inductive winding will increase exponentially until the input voltage plus the hysteresis voltage is reached across the feedback resistors. At this point, the motor driver will turn off and the voltage across the motor will reverse as the field collapses. Current will now flow through the diode D and will decrease until the hysteresis voltage is reached. The motor driver will then turn on and the cycle will repeat.

To assure switching action, a hysteresis voltage is generated with resistors R1 and R2. This adds or subtracts a small voltage from the control input depending on the output voltage of the driver (adds at +28V, subtracts at 0). The amount of hysteresis used for this case is 10 mv. Other values can be obtained, as required, by changing R1.

The frequency of switching is controlled by the hysteresis and the time constant of the motor in the middle of the current range. At the extremes, the frequency will decrease. Frequency is approximately equal to

$$f = 2 \frac{L_m}{R_m} \ln \frac{V_F}{V_F + V_h}$$

where:

$L_m$	=	inductance of motor
$R_m$	=	resistance of motor
$V_F$	=	feedback voltage
$V_h$	=	hysteresis voltage
$V_h$	=	$\frac{28 R_2}{R_1 + R_2}$

Since the control amp has to drive one of three drivers, a feedback loop is needed for the switched drivers (or gate). Three diodes and a resistor are used for this (see Figure 11). This allows the switching feedback to operate with any of the drivers.

### 1.2.2 Device Selection

The devices used are important as they determine the efficiency of the driver. Specifications of importance are low saturation voltages and fast switching speeds.

Finding the best type of output transistor was difficult. The characteristics of the group, from which the final selection was made, are shown in Table 3.

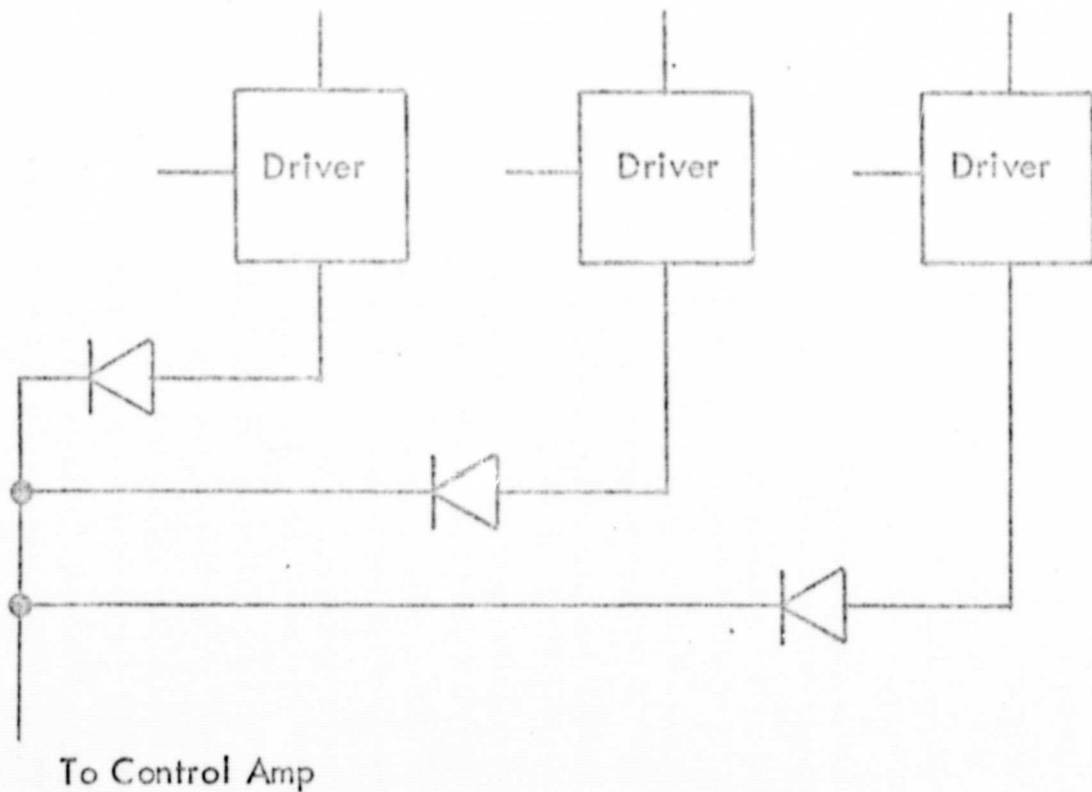

Figure 11. OR GATE

	$V_{be}^{Sat}$	$V_{ce}$	$I_{max}$	$f_T$	$H_{FE}$ (20 amps)	Chip Size
Transitron ST14030	0.8	80	60	5	60	.25 x .25
Solitron	0.8	80		15		.25 x .25
Powertech PT501	0.9	120	100	0.8	36	.5 x .5

Table 3. POWER TRANSISTOR SPECIFICATIONS

The saturation voltage maximum is defined in the specification (1.4 volts). The saturation voltage is equal to  $V_{be}$  of the output transistor and  $V_{ce}$  of the driver transistor. The transistor should be capable of rise and fall times that are 50 to 100 times faster than the period switched ( $P = \frac{1}{f}$ ).

The Powertech device was eliminated because of its chip size and its slow speed. Both the Transitron and the Solitron devices were acceptable. The Solitron transistor was used as they had the capability of mounting the transistor in a package. The mounting of a chip the size of which we are using (0.25 x 0.25 inch) is difficult and requires special equipment.

The diode used must have a fast turnoff time and be capable of handling twenty amps. A special diode was made at Solitron for this application.

### 1.2.3 Breadboard Results

A high power breadboard was built with discrete transistors that were similar to the ones to be used. A load was assembled with air-gapped iron core inductors and resistors to simulate an actual motor. Compensation of the high power unit proved to be difficult. The addition of two more gain stages within the loop of the 0.375 amp motor driver gave a total open loop voltage gain of over one million. Grounds and position of power-carrying wires became very critical.

Satisfactory compensation was obtained by using two pole-zero sets in the control amplifier, using capacitors C1, C2, and C3, and using resistors from pins 18, 25, and 26 to ground instead of a common connection. Both saturation voltages and switching operations were satisfactory although lead placement continued to be critical.

### 1.2.4 Packaging Design

Initial attempts to package the high power driver in a single package were unsuccessful due to the size of the power transistor chips used. It was therefore decided to use two packages with the upper drivers occupying one and the lower drivers another.

A package similar to a TO-3 case was selected due to the relative ease of mounting. To help dissipation, the transistor chip was mounted on a beryllia substrate which is then mounted to the base with a gold-tin preform.

The high power drivers have two specific power dissipation modes, switching and saturation. The power dissipation for a transistor when saturated (20 amps) is about 30 watts (1.5V x 20 amps). When operating in the switching mode, worst case exists just below the saturation point. This dissipation is:

Saturation losses:	~ 30 watts
Transition losses:	~ 3 watts
Total:	<hr/> 33 watts

The thermal resistance of the high power driver transistors is 0.5°C/W from junction to case. With a heatsink at 85°C and 33 watts dissipation, the allowable case to heat sink thermal resistance is:

$$R_T = \frac{200^\circ\text{C} - 85^\circ\text{C} - 0.5^\circ\text{C/W} \times 33\text{W}}{33\text{W}} = 3^\circ\text{C/W}$$

By using a filled silicon grease between package and heatsink and a total surface runout of less than 0.006 inches, the maximum thermal resistance should not exceed 0.5°C/W.

### 1.2.5 Hybrid Prototype •

A high power driver set was fabricated and mounted on a heatsink assembly. Two problems became evident after initial turn-on.

Without proper compensation in the loop, oscillations would occur. The abnormal result was that these oscillations would turn other drivers on. When an upper and lower of the same set were on (1&2, 3&4, or 5&6), a short appeared across the power supply. The power supply was current limited, but had a large capacitor on the output ( $< 5000\mu\text{f}$ ), and the amount of energy this can supply is enough to destroy the output transistors.

The second problem occurred in the lower driver. The two ohm input resistors when trimmed to value, had so little area left that they became unreliable. This problem was caused by the abrasive beating down on the resistive material and actually decreasing the resistance as the resistor was trimmed. This was corrected by using chip resistors in later models.

A second hybrid prototype package was obtained and tried with a new feedback connection (see Figure 12). This reduced the voltage gain of the circuit without effecting current gain. With this feedback circuit, a high degree of stability was obtained and the lead dress problem vanished. The compensation on the control amp was changed to one-pole zero pair.

For the switching mode, a check of the feedback voltage was conducted. There was a hysteresis of 10 mv which agreed with the calculations. Removal of the switching feedback path caused the unit to go into analog mode.

### 1.2.6 Final Design

The final circuit used is shown in Figure 14.

## 1.3 OPERATIONAL NOTES

### 1.3.1 Low Power Driver

R18, R19, R30: These should be low drift, 1% resistors. Drift should not be more than  $\pm 10$  ppm/ $^{\circ}\text{C}$ .

R<sub>f</sub>: select R<sub>f</sub> according to the maximum desired output current

$$R_f = \frac{0.2}{I_{\text{max}}}$$

Mounting: units should be mounted on a metal plate with a thin coating of Dow Corning 340 or equivalent. Adequate pressure ( $5\#/\text{IN}^2$ ) should be applied to keep the flatpack in intimate contact with the heatsink.

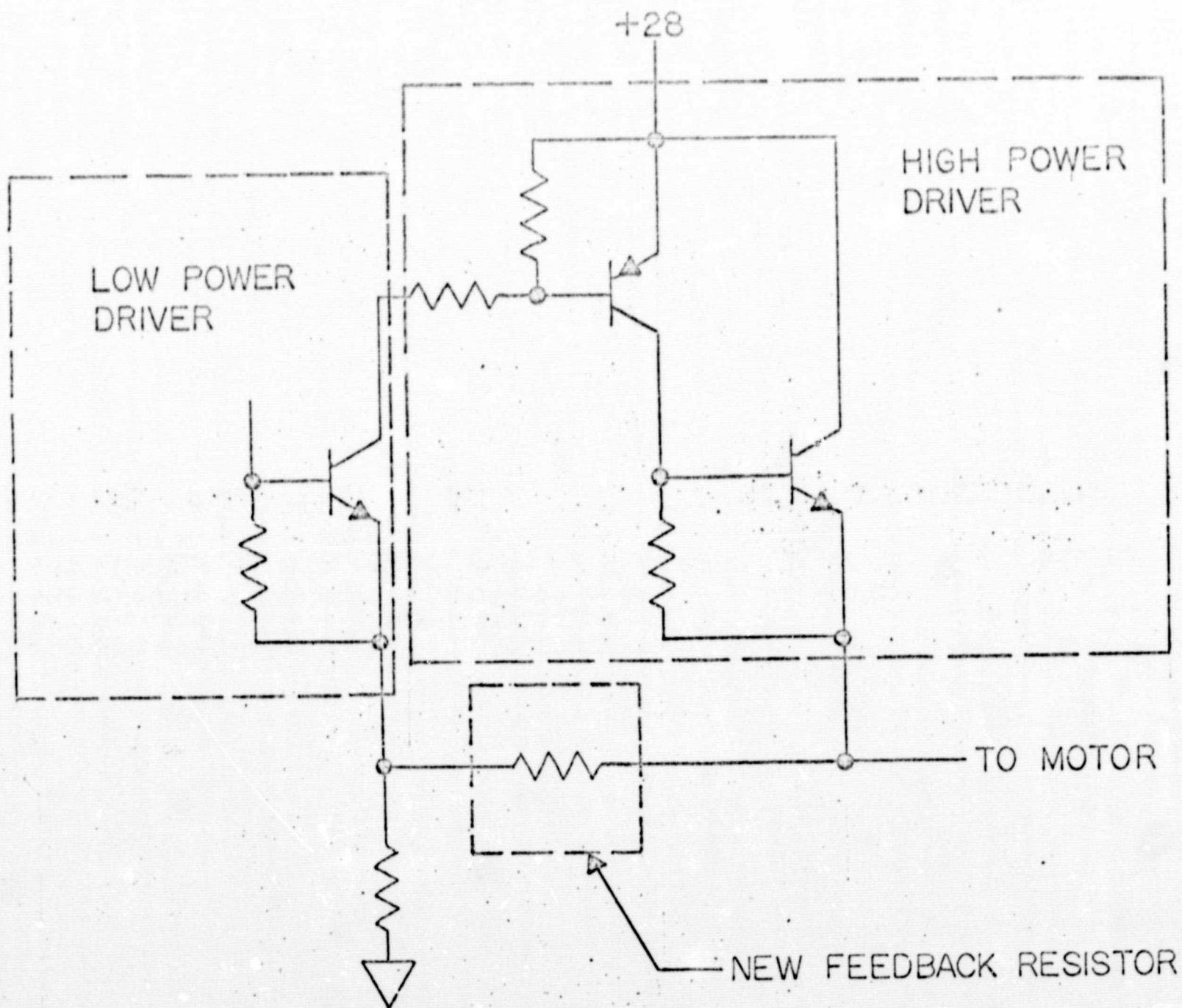

FIGURE 12. HIGH POWER DRIVER CONNECTION

If a lower temperature drift is desired, the amount of feedback can be increased. This involves the increasing of  $R_f$  and the decreasing of  $R_{10}$ .

### 1.3.2 High Power Driver

$R_{18}$ ,  $R_{19}$ ,  $R_{30}$ : These should be low drift, 1% resistors. Drift should not exceed  $\pm 10$  ppm/ $^{\circ}\text{C}$ .

$R_f$ ,  $R_a$ ,  $R_b$ : select  $R_f$ ,  $R_a$ ,  $R_b$  according to the maximum desired output current.

$$R_f = \frac{0.2}{I_{\max}}$$

$$R_a = \frac{2800}{I_{\max}}$$

$$R_b = \frac{1}{2} R_a$$

**Switching Operation:** Hysteresis is controlled by raising or lowering of resistor  $R_{22}$ . For more hysteresis, a resistor can be connected from pin 4 to pin 3 (parallels  $R_{22}$ ) and for less hysteresis, a resistor can be put in series with the line coming into Pin 4.

**Switching Frequency:** Approximate switching frequency can be calculated using:

$$f = 2 \frac{L_{\text{motor}}}{R_{\text{motor}}} \ln \frac{V_{\text{feedback}}}{V_{\text{feedback}} + \text{hysteresis}}$$

**Mounting:** Package should be bolted to an appropriate heatsink with two mounting bolts. A thin coating of Dow Corning 340 or equivalent should be used between the heatsink and driver.



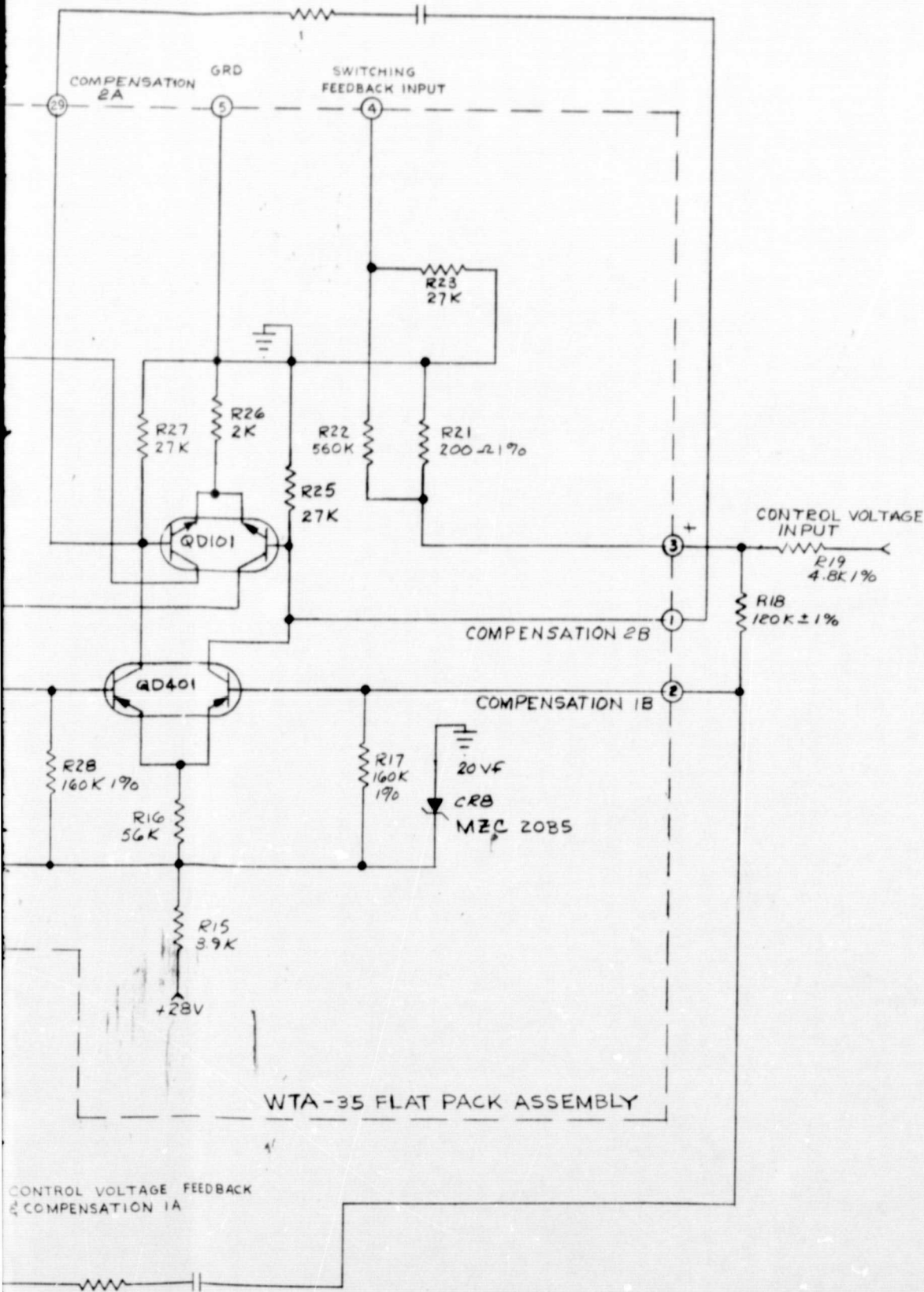

NOTES:  
 1. LAST REF DESIGNATIONS USED  
 ARE: R80  
 CR8  
 C3  
 Q19

0.375 AMP MOTOR DRIVER

Figure 13

# FOLDOUT FRAME

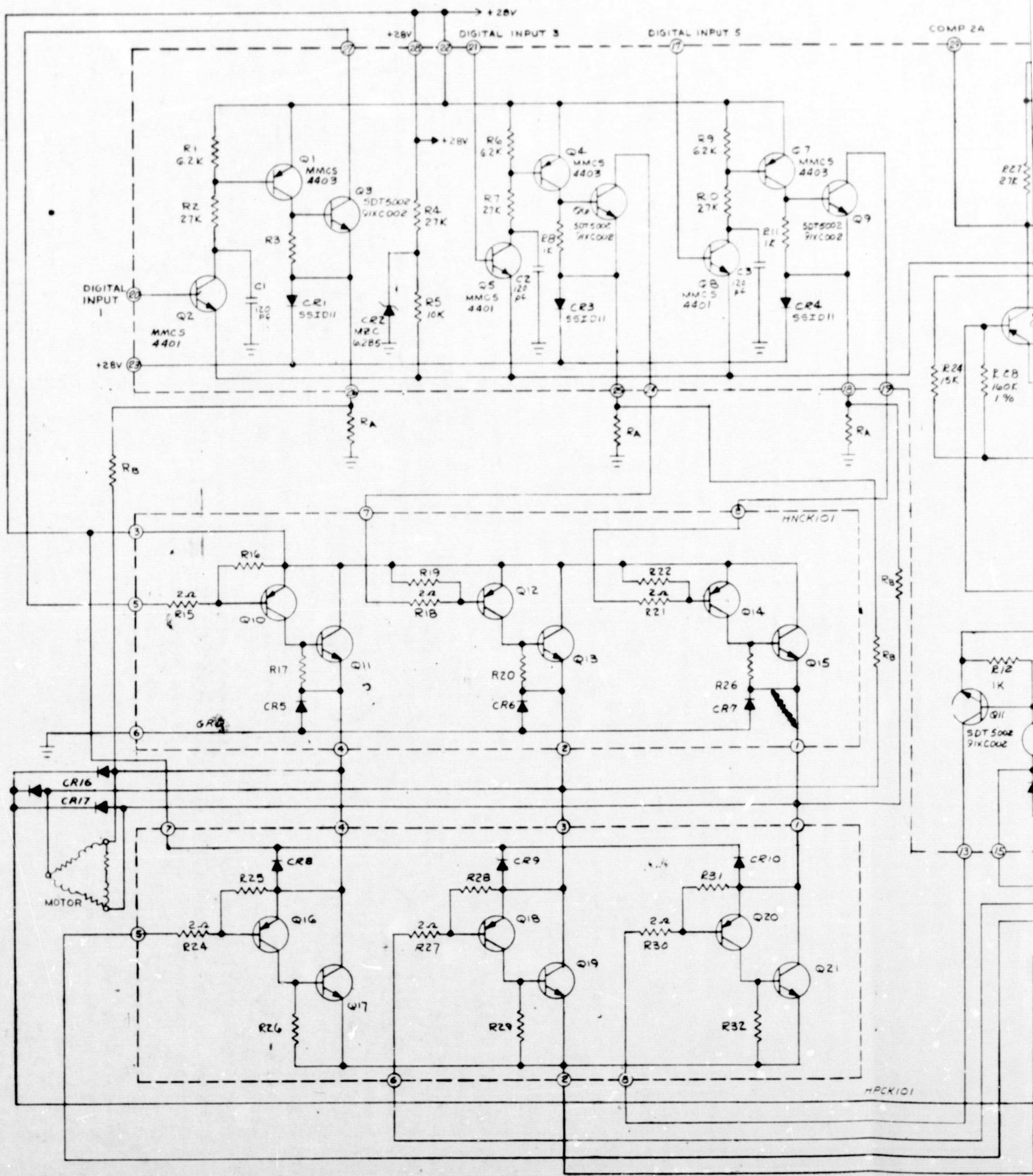

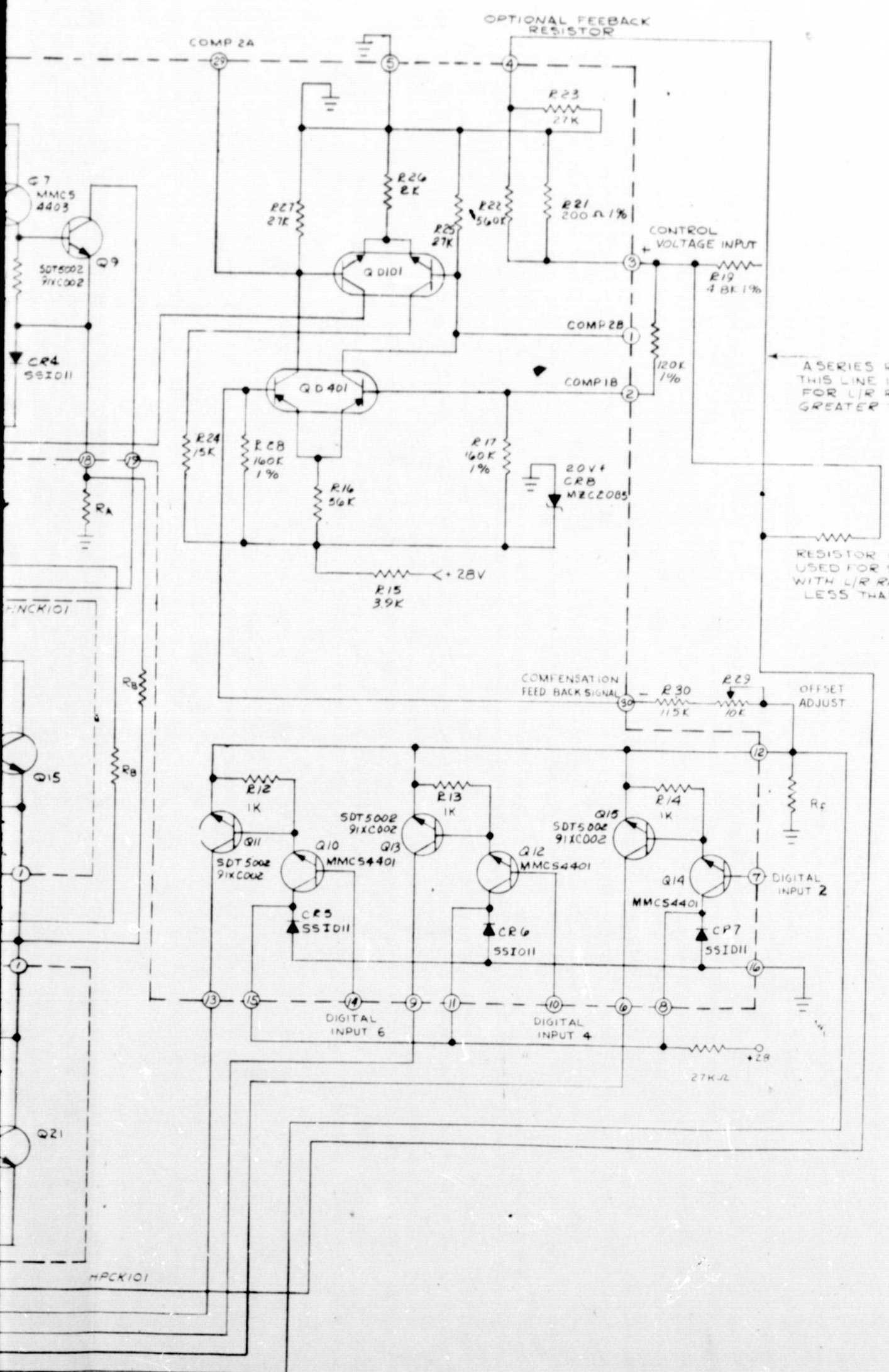

A SERIES RESISTOR IN THIS LINE IS NEEDED FOR L/R RATIOS GREATER THAN 0.01

RESISTOR OPTIONAL USED FOR SWITCHING WITH L/R RATIOS LESS THAN 0.01

NOTES :

1. CIRCUIT GOES INTO ANALOG CONTROL WHEN THE SWITCHING FEEDBACK IS LEFT OPEN.
2. LAST REF DESIGNATIONS USED ARE :

$$3. R_f = \frac{e_2}{I_{MAX}}$$

$$4. R_a = \frac{2800}{I_{MAX}} \sim R_b = \frac{1}{2} R_a$$

HIGH POWER MOTOR DRIVER

Figure 14

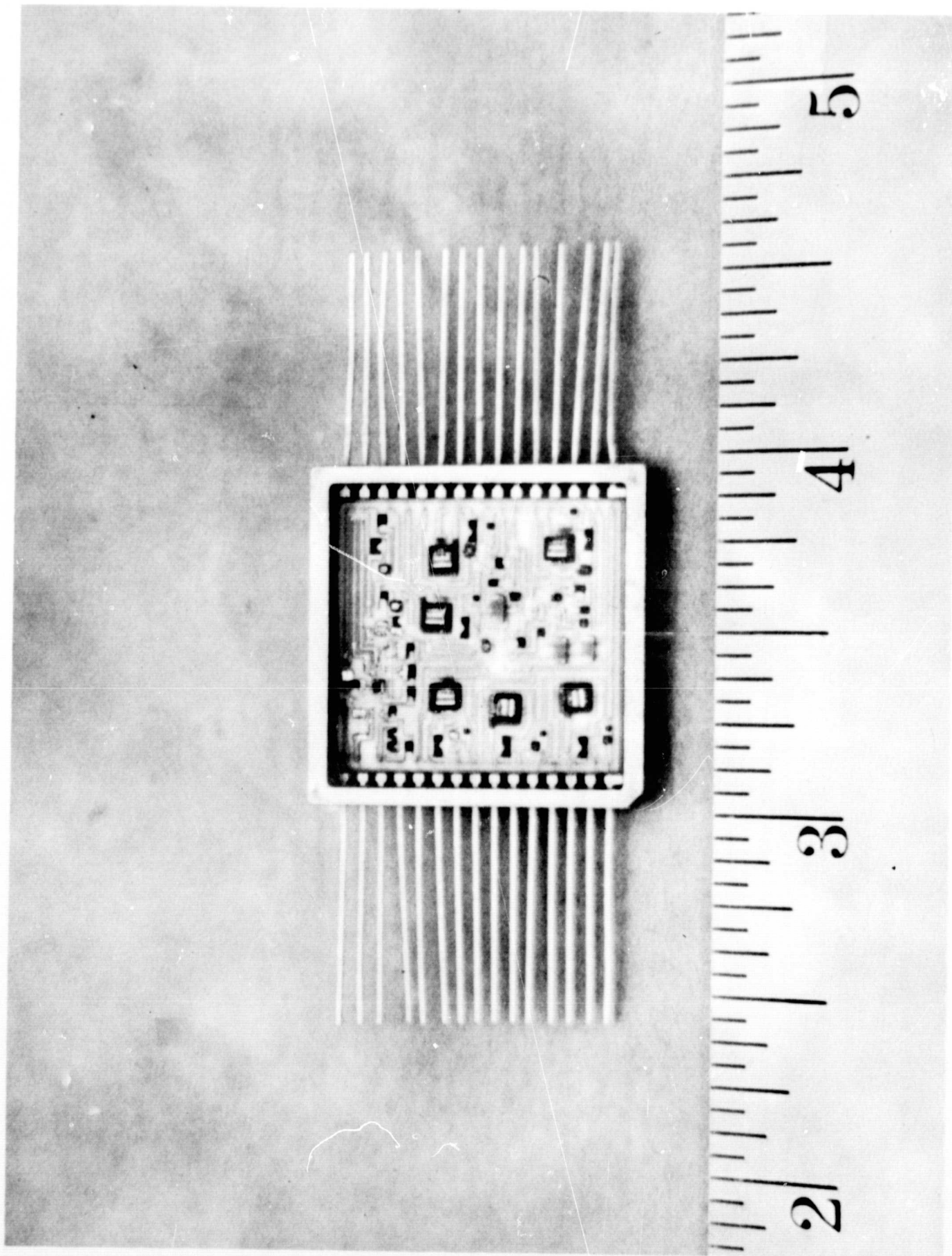

Figure 15. LOW POWER DRIVER

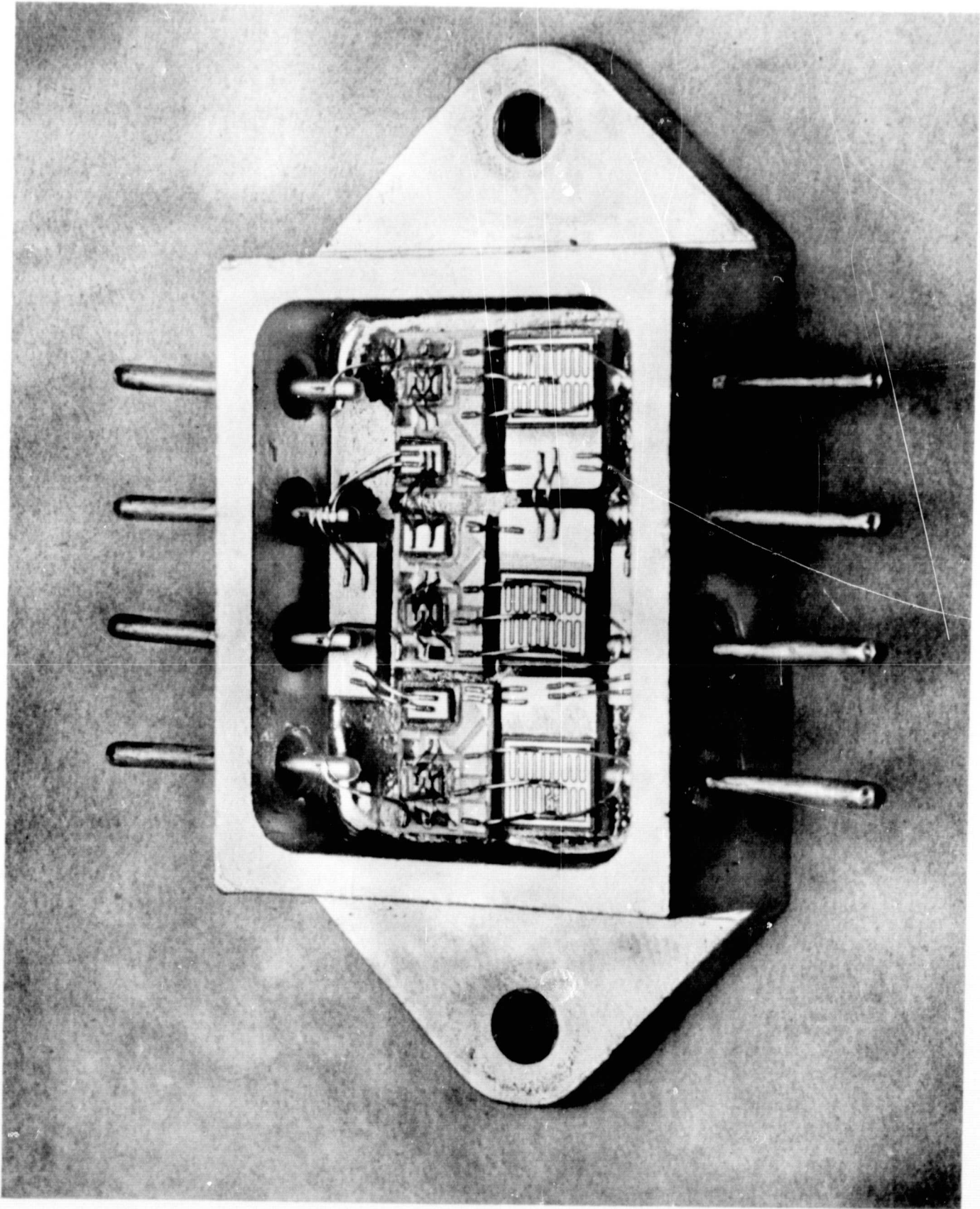

Figure 16. HIGH POWER DRIVER