

NASA TECHNICAL
MEMORANDUM



NASA TM X-2361

NASA TM X-2361

CASE FILE
COPY

FLOW RESISTANCE OF PERFORATED
PLATES IN TANGENTIAL FLOW

by

Marvin Budoff

George Washington University

and

William E. Zorumski

Langley Research Center

NATIONAL AERONAUTICS AND SPACE ADMINISTRATION • WASHINGTON, D. C. • OCTOBER 1971

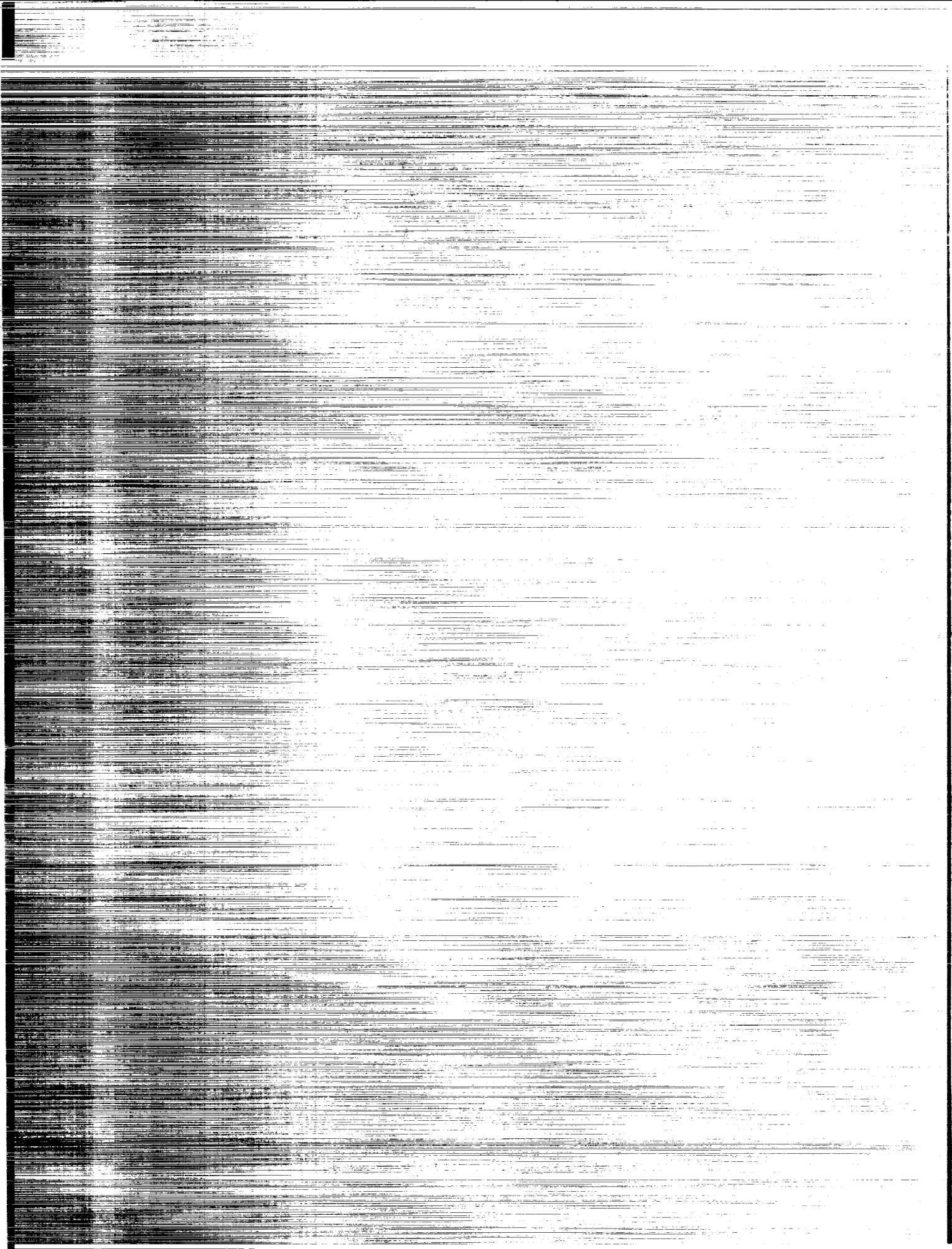

1. Report No. NASA TM X-2361	2. Government Accession No.	3. Recipient's Catalog No.	
4. Title and Subtitle FLOW RESISTANCE OF PERFORATED PLATES IN TANGENTIAL FLOW		5. Report Date September 1971	6. Performing Organization Code
		8. Performing Organization Report No. L-7874	10. Work Unit No. 136-80-01-04
7. Author(s) Marvin Budoff (George Washington University) and William E. Zorumski		11. Contract or Grant No.	
9. Performing Organization Name and Address NASA Langley Research Center Hampton, Va. 23365		13. Type of Report and Period Covered Technical Memorandum	
		14. Sponsoring Agency Code	
12. Sponsoring Agency Name and Address National Aeronautics and Space Administration Washington, D.C. 20546		15. Supplementary Notes	
16. Abstract <p>This experimental study investigated changes in flow resistance of perforated plates resulting from varying the tangential flow across the plate surface, the direction and magnitude of normal flow through the plate, and the number of holes in the plate, keeping the open area constant. As expected, flow resistance increased with increases in tangential and normal flow. A discontinuity in flow resistance was found when the direction of normal flow was reversed. At higher tangential-flow Mach numbers the flow resistance decreased as the number of holes in the plate increased and hole size decreased.</p>			
17. Key Words (Suggested by Author(s)) Tangential flow Flow resistance Perforated plates		18. Distribution Statement Unclassified - Unlimited	
19. Security Classif. (of this report) Unclassified	20. Security Classif. (of this page) Unclassified	21. No. of Pages 11	22. Price* \$3.00

FLOW RESISTANCE OF PERFORATED PLATES
IN TANGENTIAL FLOW

By Marvin Budoff
George Washington University

and

William E. Zorumski
Langley Research Center

SUMMARY

Flow resistance of four perforated plates with constant open area (2.18 percent) was studied experimentally at Langley Research Center as a function of the normal flow through the plates and the number and geometry of the holes, with tangential flow across the plate surface as a parameter.

An increase in flow resistance was found as normal-flow Mach number increased from 10^{-4} to 10^{-1} . Increasing the tangential-flow Mach number from 0 to 0.44 resulted in further increases in the flow resistance of the plates.

Flow resistances found for normal flow into the tangential-flow duct were higher than for the same normal flow out of the duct, indicating a discontinuity in flow resistance when normal flow was reversed. This discontinuity increased as tangential flow increased.

For the four plates studied, the number of holes ranged from one to 64 and the hole diameters ranged from 0.63 cm for the single-hole sample to 0.08 cm for the 64-hole sample. Hole depth was kept constant at 0.32 cm. It was observed that at the higher tangential-flow Mach numbers, the flow resistance decreased as the number of holes in the plate increased. In addition, the rate of increase in the flow-resistance discontinuity was found to be less for the plates with the most holes, suggesting a leveling off of this effect as the number of holes increases and hole diameter decreases.

INTRODUCTION

Much concern in recent years has been expressed over the high noise levels emanating from jet engines. One way of dealing with this problem involves the reduction of the noise, particularly fan noise radiated from the inlet and fan discharge ducts, through acoustical treatment of the nacelle. Considerable work has, therefore, been done to

determine the acoustic characteristics of possible lining materials for jet engine ducts, as indicated in reference 1.

The acoustic behavior of candidate duct-lining materials is dependent on the fluid flow within the duct. In a jet-engine duct, a steady flow of fluid is induced tangentially across the surface of the acoustic material. In addition, the acoustic field induces an oscillating flow through the material. The interaction between these flow fields produces changes in the acoustic properties of the material.

In recent studies concerning nonlinear acoustic effects in porous materials Zorumski and Parrott (ref. 2) have noted, based on their own data and earlier studies by others working in similar areas, that the acoustic properties of a rigid porous solid can be described completely, in the absence of tangential flow, by two nonlinear functions of instantaneous velocity – the resistance function and reactance function. Zorumski and Parrott further found that the instantaneous resistance is independent of frequency and is, therefore, equivalent to the flow resistance of the material. The flow resistance can be defined as the ratio of the pressure drop across a material to the steady airflow velocity through the material. The results of some work with acoustic materials by Feder and Dean (ref. 3) show a very close correspondence between the acoustic and flow resistances in the presence of tangential flow.

It was the purpose of this study to investigate experimentally the change in acoustic properties of perforated plates resulting from the interaction of flows normal and tangential to the plates. The easily measured flow resistance of the material was used as a measure of the acoustic resistance in order to simplify the experimental procedure. Flow-resistance changes resulting from reversing the flow through the sample are also studied and presented. The acoustic materials studied are four perforated plates with different numbers of holes and with a constant open area maintained. This allows additional observations to be made concerning the effects of varying the hole number and size on the flow resistance of the material studied.

SYMBOLS

A_o	open-area ratio of samples
c	speed of sound (STP), 331.6 m/sec
M	center-line Mach number of tangential-flow velocity
M_n	Mach number of average normal-flow velocity

p_1	static pressure in branch channel, mm Hg or N/m^2
p_2	static pressure in tangential-flow channel, mm Hg or N/m^2
q_2	dynamic pressure in tangential-flow channel, mm Hg
R	flow resistance of sample, $\frac{p_1 - p_2}{V}$, rayls or $kg/m^2\text{-sec}$
V	average velocity of normal flow, cm/sec
$\rho_0 c$	standard characteristic impedance of air, 415 rayls

APPARATUS AND MEASUREMENT PROCEDURES

Test Apparatus and Instrumentation

Schematic illustrations of the equipment setup are shown in figures 1 and 2. A flow was induced by a vacuum source in a rectangular channel 7.62 cm wide and 3.81 cm high. A perforated plate was mounted in the side of the channel, 40 cm from the tangential-flow inlet. A pitot-pressure probe was located in the center of the channel measuring the static and dynamic pressures p_2 and q_2 at the midpoint of the sample. Pitot-pressure probes used in this experiment were made from tubing having a 0.301-cm outside diameter and a 0.191-cm wall thickness with static-pressure holes located 1.27 cm from the blunt nose and 4.23 cm from the probe-stem axis. At the sample the branch channel was connected to the vacuum source and also to a pressure source. By closing the vacuum source and opening the pressure source, the flow through the sample could be reversed. Three rotometer-type flowmeters were mounted in the branch-channel pipe network. These flowmeters could measure the average velocity across the sample, calculated on the basis of incompressible flow, ranging from 1 cm/sec to 10^3 cm/sec, which corresponds to the range of sound pressure level of 107 dB to 167 dB (free-space, plane wave propagation). A second pitot-pressure probe was located in the center of the branch channel with its static-pressure holes 3.81 cm from the sample. A digital voltmeter allowed direct readings of the pressure difference across the sample to be made. This pressure difference, $p_1 - p_2$, was measured by a pressure transducer with a range of 100 mm Hg connected to the pitot static-pressure taps in the main channel and in the branch channel. Photographs of the actual equipment are shown in figures 3 and 4.

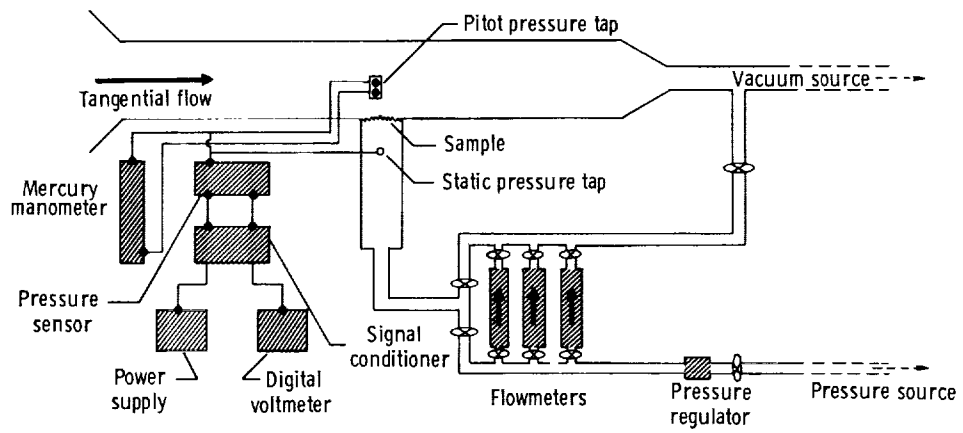

Figure 1.- Schematic drawing of apparatus.

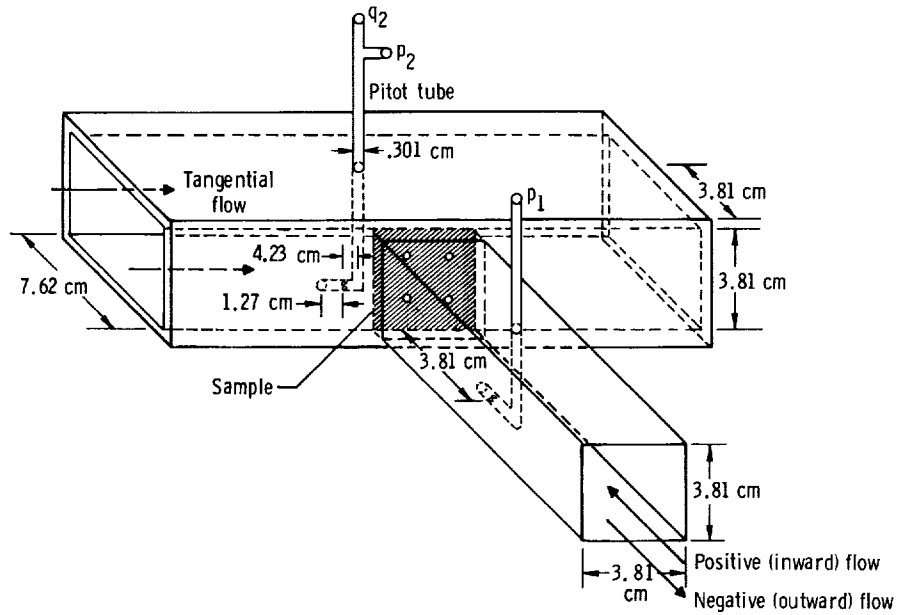
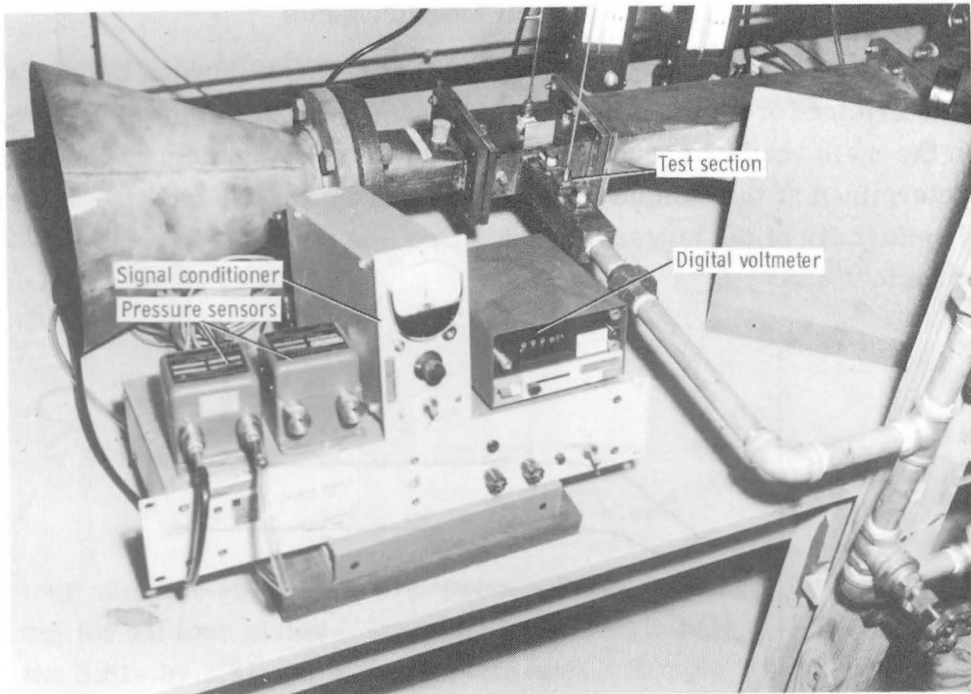
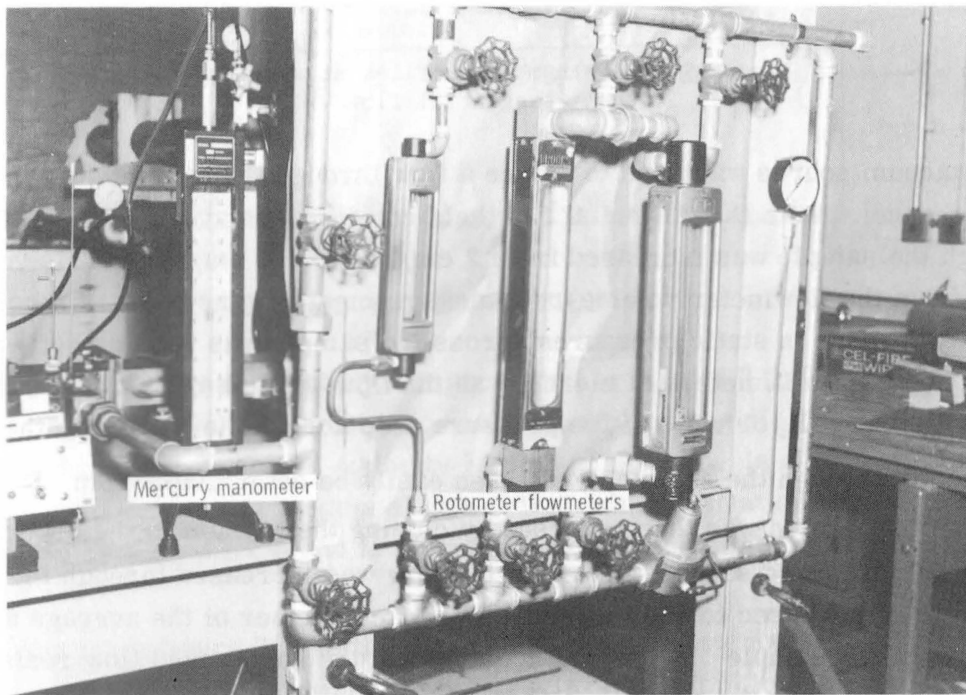

Figure 2.- Test section (40 cm from tangential-flow intake to sample).



L-71-2402.1

Figure 3.- Photograph of test section, pressure sensors, signal conditioner, and digital voltmeter.



L-71-2404.1

Figure 4.- Flowmeter arrangement; manometer for determining tangential-flow Mach number.

Procedures and Measurements

The center-line Mach number M of the tangential flow across the surface of the sample was determined from the difference in dynamic and static pressures q_2 and p_2 measured in the main channel and read from a mercury manometer. Mach number profiles were determined at the sample (located 40 cm from the air intake opening) to observe the uniformity of the tangential flow. Profiles for three tangential flows are shown in figure 5.

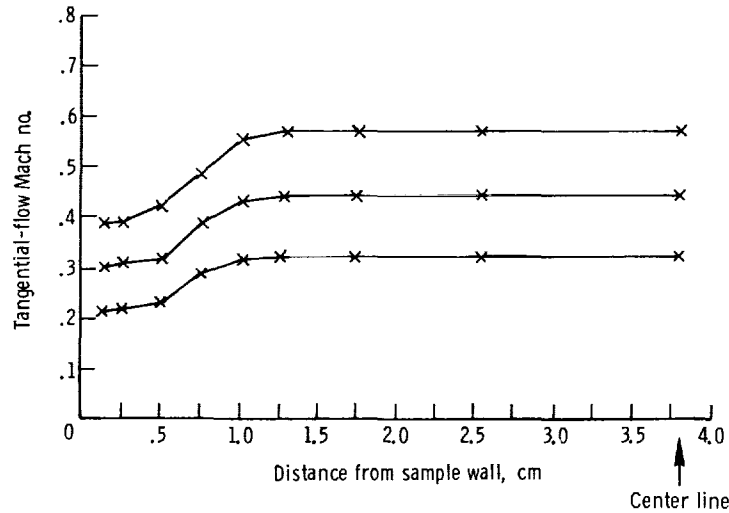

Figure 5.- Mach number profiles at sample for three tangential flows.

The vacuum source was used to induce a flow through the sample outward from the tangential channel. With the tangential flow held constant, the average velocity of the flow through the sample was increased from 2 cm/sec to 400 cm/sec. This velocity was calculated from the flowmeter volume-rate measurements on the basis of incompressible flow. The difference in static pressures across the sample was read directly from the digital voltmeter in millimeters of mercury as the flow through the sample increased. The flow resistance R , or ratio of the pressure drop across the sample to the average airflow velocity through the sample, could then easily be determined from $R = \frac{p_1 - p_2}{V}$. Flow through the sample was then reversed by closing the vacuum to the branch channel and opening the pressure source, and again the flow was increased through the same velocity range of 2 cm/sec to 400 cm/sec. The Mach number of the average airflow velocity through the sample M_n was calculated and the normalized flow resistance $R/\rho_0 c$ was plotted against $\sinh^{-1}(10^4 M_n)$. This allowed comparisons to be made of the symmetry of the plots of the flow-resistance changes resulting from the reversed flow through the sample. This procedure was followed for tangential-flow Mach numbers of 0, 0.15, 0.29, and 0.44.

Test Specimens

In order to observe the effect on flow resistance of the number and geometry of the holes, four aluminum plates were used. (See fig. 6.) The open-area ratio was kept

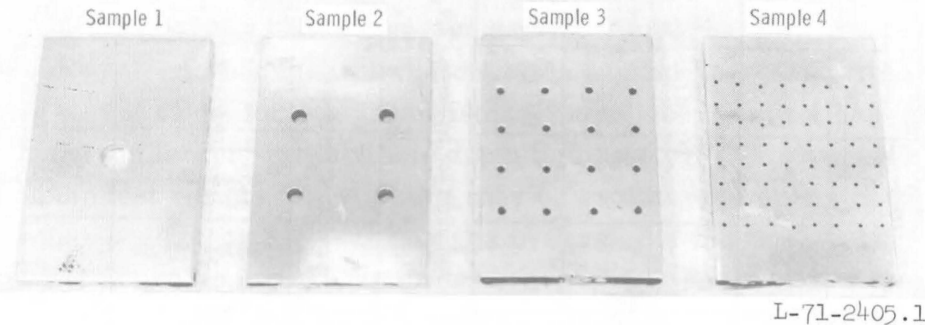

Figure 6.- Samples of perforated plates.

constant for all four samples at $A_o = 2.18$ percent. Plate depth and, therefore, hole depth, was 0.32 cm for all four plates. Sample 1 had a single hole of 0.63-cm diameter in the center of the 3.81- by 3.81-cm exposed plate area. Sample 2 had four 0.32-cm-diameter holes, sample 3 had sixteen 0.16-cm-diameter holes, and sample 4 had sixty-four 0.08-cm-diameter holes. Other geometric factors are summarized below.

Sample	No. of holes	$\frac{\text{Depth}}{\text{Diameter}}$	Reynolds number range (based on diameter)
1	1	1/2	8.44 to 1688.40
2	4	1	4.28 to 86.26
3	16	2	2.14 to 43.13
4	64	4	1.06 to 21.56

RESULTS AND DISCUSSION

The results obtained from the study are presented in figures 7 to 9. Figure 7(a) shows the variation in flow resistance with normal velocity for sample 1. As expected, R increased with the average normal-velocity Mach number M_n in each direction of the normal flow, in the absence of tangential flow. With slight variations at the lower M_n values, similar results were found at tangential-flow Mach numbers of 0.15, 0.29, and 0.44.

Also apparent from figure 7(a) is the increase in flow resistance resulting from each rise in tangential-flow Mach number. This result is true for flow in either direction through the sample. Note, however, that the increases were greater for positive (inward) flow through the sample than for negative (outward) flow. This disparity in rate of increase led to progressively larger discontinuities in the flow resistance as

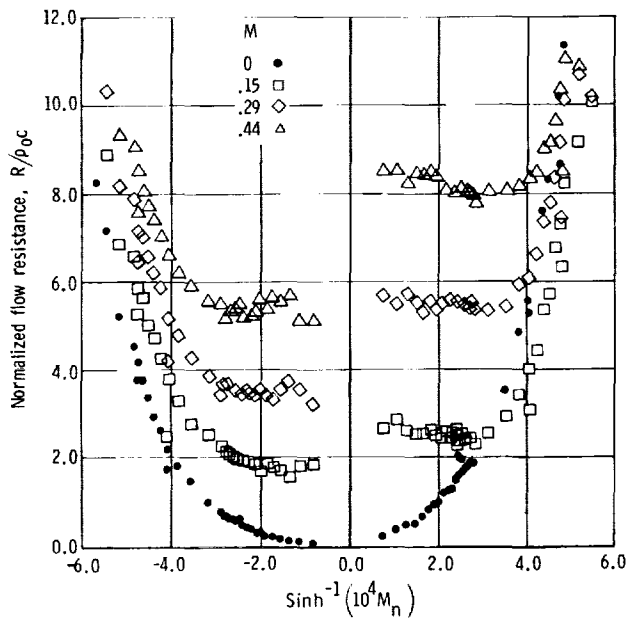

(a) Sample 1 (1 hole).

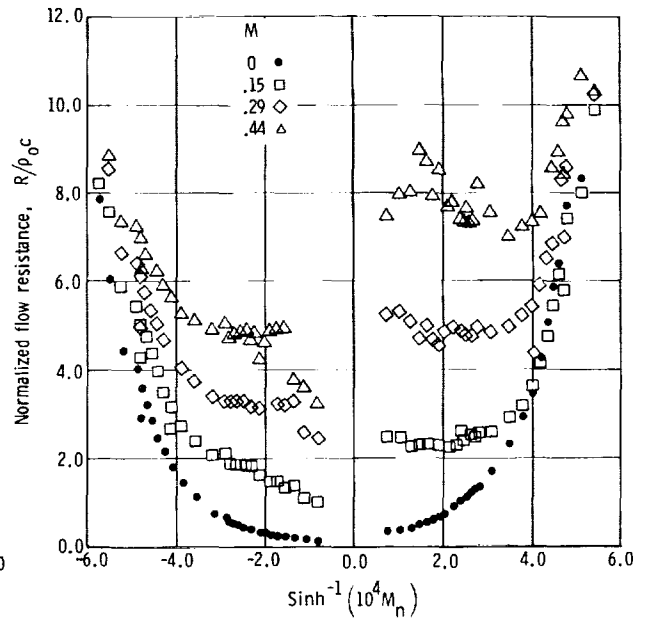

(b) Sample 2 (4 holes).

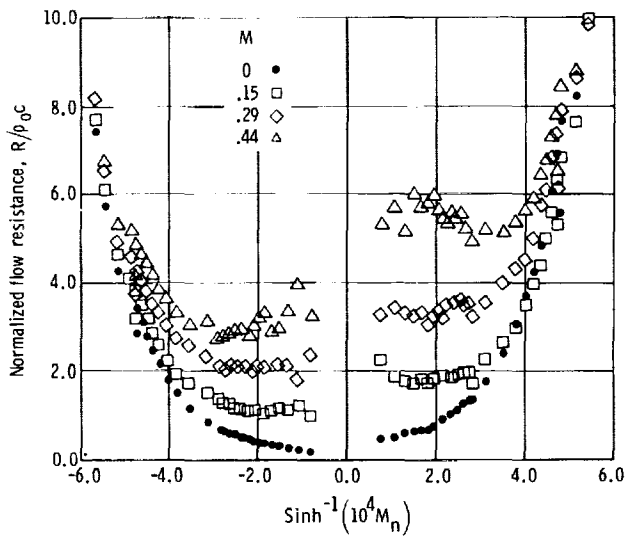

(c) Sample 3 (16 holes).

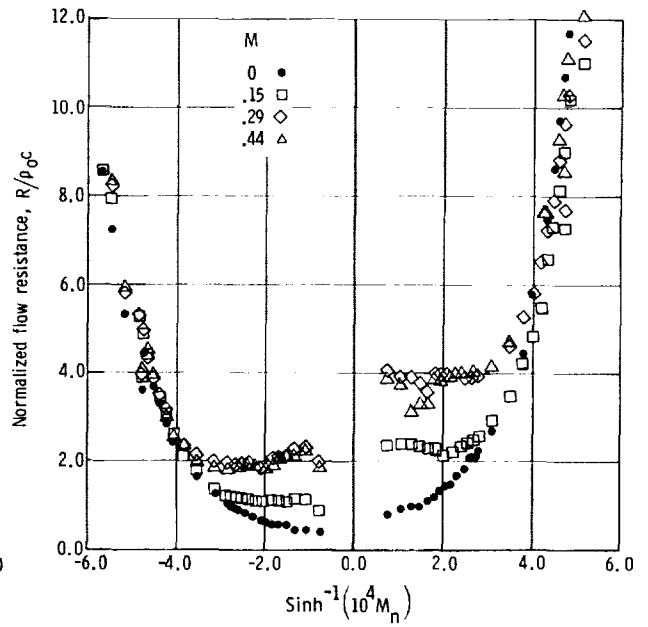

(d) Sample 4 (64 holes).

Figure 7.- Variation in flow resistance with normal velocity for several values of tangential-flow Mach number. The range of M_n in each direction is 10^{-4} to 10^{-1} .

tangential flow increased. As a result, an inceptive "rectifier-type" effect was observed, with greater resistances found for flow in the inward direction than for the same flow velocity in the outward direction, and with the effect increasing for larger tangential flows.

Figures 7(b), 7(c), and 7(d) show similar effects for the other samples with 4, 16, and 64 holes, respectively. However, for sample 4 (see fig. 7(d)) it was found that flow resistance decreased when tangential-flow Mach number increased from 0.29 to 0.44. Speculating on the cause for this inconsistency, note that sample 4 has the smallest diameter holes and the largest ratio of hole depth to diameter. This suggests that the inconsistency in the test results for sample 4 may be explained in terms of the sample's geometry. Another possibility involves changes in density of the fluid around the sample, and an explanation may also involve compressibility effects at the higher tangential-flow Mach numbers. Further studies may indicate other explanations in terms of the ratio of duct height to hole diameter or the interaction between the greater velocity flows and instrumentation.

At the lower tangential Mach numbers of 0 and 0.15, varying the number of holes and hole geometry did not produce significant changes in $R/\rho_0 c$. However, as figures 8(a) and 8(b) indicate, there were some notable changes in flow resistance at $M = 0.29$ and $M = 0.44$ as the number of holes and hole geometry varied, holding the open area constant. Interestingly, the trend in both cases was toward a decrease in flow resistance as the number of holes increased and hole size decreased.

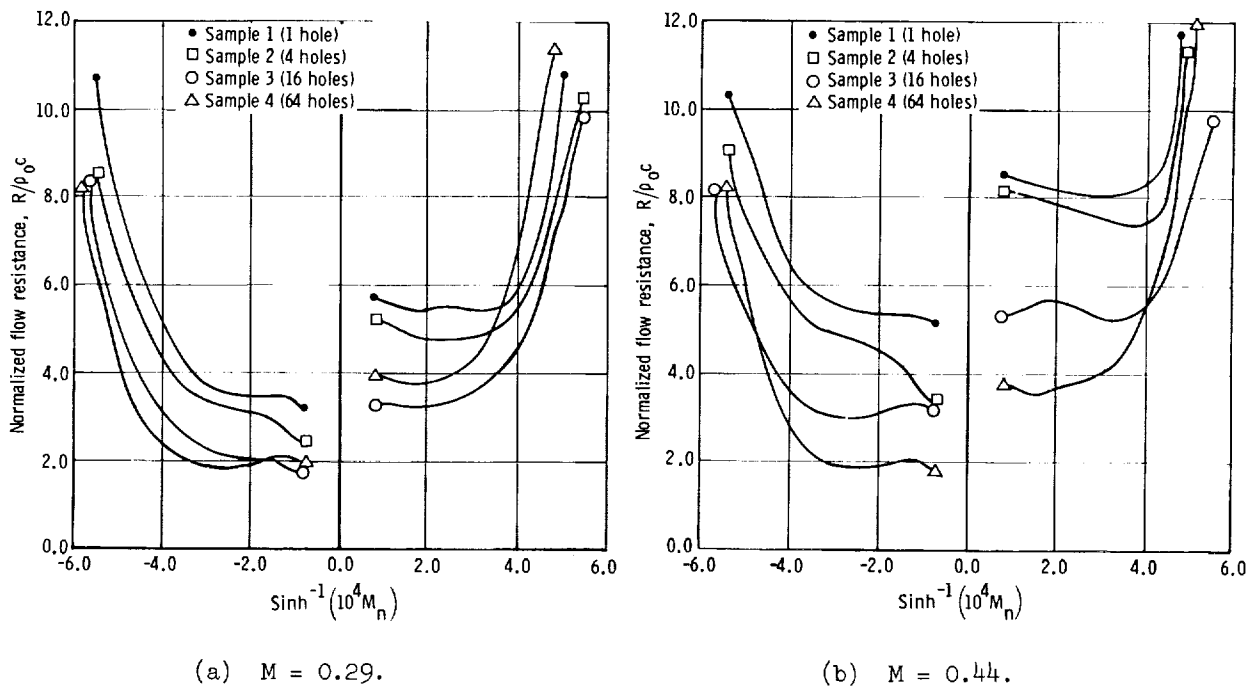

Figure 8.- Variation in flow resistance with normal velocity. The range of M_n in each direction is 10^{-4} to 10^{-1} .

It was noted previously that the discontinuity in flow resistance between equal positive (inward) and negative (outward) flows increased as tangential flow increased for nearly all samples. Another aspect of this phenomenon is apparent in figure 9, which

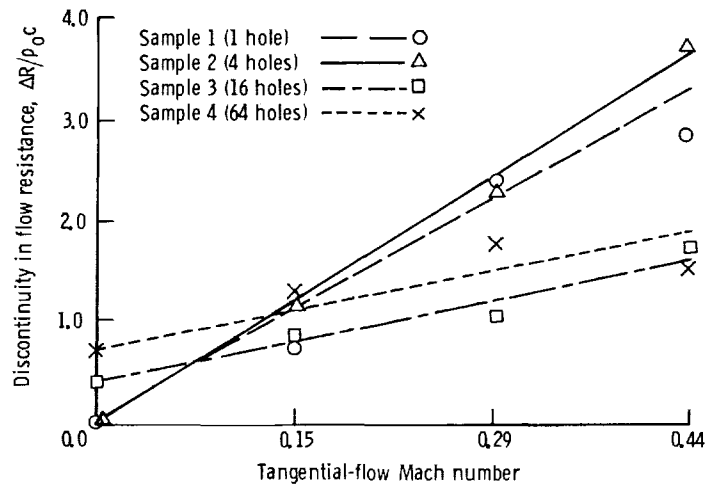

Figure 9.- Discontinuity in flow resistance resulting from normal-flow reversal.

shows this trend of increasing flow-resistance discontinuity for each of the samples. In the ranges tested, the plots are generally linear. For samples 1 and 2, however, the slopes are greater than for samples 3 and 4, in which the number of holes increased. This indicates that the "rectifier-type" effect noted earlier maintained a more nearly constant value for samples 3 and 4, rather than becoming significantly larger for increased tangential flows as is the case with samples 1 and 2.

CONCLUDING REMARKS

An experimental study was made at Langley Research Center to investigate the flow resistance of perforated plates in tangential flow. Based on the four perforated plates studied, flow resistance was found to increase with tangential flow. Flow resistance also increased with normal flow. Reversing the normal flow through the plate resulted in a flow-resistance discontinuity, with higher flow resistance for flow into the tangential-flow channel than for the same flow moving outward. Increasing the number of holes and decreasing the hole diameter appeared to cause significant flow-resistance changes, but only at the higher tangential-flow Mach numbers. The samples with more holes of small diameter had less increase in the flow-resistance discontinuity than did samples with fewer holes of larger diameter.

Zorumski and Parrott (NASA TN D-6196) demonstrated that the nonlinear acoustic resistance was a function of only the normal velocity in the absence of tangential flow.

The present study has shown that the flow resistance is a function of two variables – the normal acoustic velocity and the tangential-flow velocity. Since the acoustic resistance and flow resistance are equal in the absence of tangential flow, this study implies that the acoustic resistance is also a function of both the normal and tangential velocities and that the flow resistance is a measure of the acoustic resistance in the presence of tangential flow. This result must be verified by acoustic tests. Also, the nonlinear reactance function must be determined by acoustic tests in the presence of tangential flow in order to provide a complete description of the behavior of acoustic materials in the typical aircraft-engine environment.

Langley Research Center,
National Aeronautics and Space Administration,
Hampton, Va., September 10, 1971.

REFERENCES

1. Anon.: Proceedings of the Aircraft Noise Symposium – Acoustical Duct Treatments for Aircraft. J. Acoust. Soc. Amer., vol. 48, no. 3, pt. 3, Sept. 1970, pp. 779-842.
2. Zorumski, William E.; and Parrott, Tony L.: Nonlinear Acoustic Theory for Rigid Porous Materials. NASA TN D-6196, 1971.
3. Feder, Ernest; and Dean, Lee Wallace, III: Analytical and Experimental Studies for Predicting Noise Attenuation in Acoustically Treated Ducts for Turbofan Engines. NASA CR-1373, 1969.



