

2  
M-1X

DMS-DR-1108  
JULY 1971

—SPACE SHUTTLE—

CR - 119972

# INVESTIGATION OF THE McDONNELL-DOUGLAS ORBITER AND BOOSTER SHUTTLE MODELS IN PROXIMITY AT MACH NUMBERS 2.0 TO 6.0

## VOLUME II MACH NUMBER 5 ORBITER PROXIMITY DATA

by

- L. L. Trimmer; AEDC
- D. A. Love, LMSC/HREC
- J. P. Decker, LaRC
- K. L. Blackwell, MSFC
- R. H. Burt, AEDC
- J. M. Rampy, LMSC/HREC

AEDC - VKF TUNNEL A

ARNOLD ENGINEERING  
DEVELOPMENT CENTER

SADSAC SPACE SHUTTLE  
AEROTHERMODYNAMIC  
DATA MANAGEMENT SYSTEM

CONTRACT NAS8-4016  
MARSHALL SPACE FLIGHT CENTER

SPACE DIVISION  CHRYSLER CORPORATION



FACILITY FORM 602

426  
426  
CR-119972  
426  
63  
31

(ACCESSION NUMBER)  
(PAGES)  
(NASA CR OR TMX OR AD NUMBER)  
(THRU)  
(CODE)  
(CATEGORY)

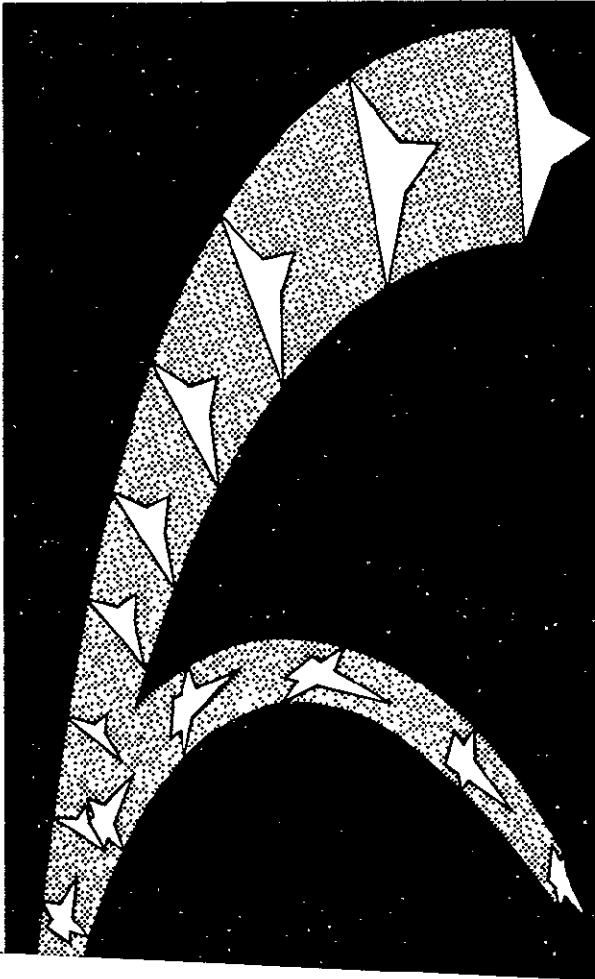

JULY, 1971

SADSAC/SPACE SHUTTLE  
WIND TUNNEL TEST DATA REPORT

CONFIGURATION: McDonnell-Douglas Orbiter and Booster Shuttle Models; 0.00556  
Scale

TEST PURPOSE: Experimental Aerodynamic Investigation of Space Shuttle Booster  
and Orbiter Vehicles in Close Proximity at Mach Numbers of 2.0  
to 6.0

TEST FACILITY: AEDC-VKF Tunnel A

TESTING AGENCY: LARC/MSFC

TEST NO. & DATE: AEDC VA 1163; 21 through 27 April 1971

SADSAC COORDINATORS: L. L. Trimmer AEDC  
D. A. Love LMSC/HREC

PROJECT ENGINEERS: J. P. Decker LARC  
K. L. Blackwell MSFC  
R. H. Burt AEDC  
J. M. Rempy LMSC/HREC

DATA MANAGEMENT SERVICES

LIAISON: *G. G. McDonald*  
for G. G. McDonald

DATA OPERATIONS: *J. L. Glynn*  
J. L. Glynn

RELEASE APPROVAL: *J. L. Glynn*  
FOR D. Kemp, Supervisor  
Aero-Thermo Data Group

CONTRACT NAS8-4016

AMENDMENT 151

DRL 184 - 58

This report has been prepared by Chrysler Corporation Space Division under a Data Management Contract to the NASA. Chrysler assumes no responsibility for the data presented herein other than its display characteristics.

Mr. L. L. Trimmer  
VKF - SH  
AEDC  
Arnold Air Force Station,  
Tennessee 37389

Phone: (615)455-2671 Ext. 7377

Mr. D. A. Love  
Lockheed Missile & Space Company  
Huntsville Research Engineering Center  
4800 Bradford Blvd.  
Huntsville, Alabama 35805

Phone: (205) 837-1800 Ext. 378

PROJECT ENGINEERS:

Mr. J. P. Decker  
Langley Research Center  
Langley Station  
Hampton, Virginia 23365

Phone: (703) 827-3911

Mr. K. L. Blackwell  
Marshall Spaceflight Center  
Mail Stop S&E - AERO - AAE  
Huntsville, Alabama 35801

Phone: (205) 453-2517

Mr. R. H. Burt  
AEDC  
Arnold Air Force Station,  
Tennessee 37389

Phone: (615) 455-2671 Ext. 7533

Mr. J. M. Rampy  
Lockheed Missile & Space Company  
Huntsville Research Engineering Center  
4800 Bradford Blvd.  
Huntsville, Alabama 35805

Phone: (205) 837-1800 Ext. 335

SADSAC LIAISON:

Mr. G. G. McDonald  
Chrysler Corporation Space Division  
102 Wynn Drive  
Huntsville, Alabama 35805

Phone: (205) 895-1341

SADSAC OPERATIONS:

Mr. J. L. Glynn  
Chrysler Corporation Space Division  
P. O. Box 29200  
New Orleans, Louisiana 70129

Phone: (504) 255-2304

## ABSTRACT

This report presents aerodynamic data obtained from a joint Langley Research Center (LaRC)/Marshall Space Flight Center (MSFC) Space Shuttle abort stage separation wind tunnel test. The .00556 scale models of the McDonnell-Douglas orbiter and booster configurations were tested in close proximity using dual balances in Tunnel A of the Von Karman Facility (VKF), Arnold Engineering Development Center (AEDC) during the time period of April 21 to April 27, 1971. Data were obtained for both booster and orbiter over an angle of attack range from  $-10^{\circ}$  to  $10^{\circ}$  for zero degree sideslip angle. The models were tested at several relative incidence angles and separation distances and power conditions. Plug nozzles utilizing air were used to simulate booster and orbiter plumes at various altitudes along a nominal ascent trajectory. Powered conditions were 100, 50, 25 and 0 percent of full power for the orbiter and 100, 50 and 0 percent of full power for the booster. Pitch control effectiveness data were obtained for both booster and orbiter with power on and off. In addition, launch vehicle data with and without booster power were obtained utilizing a single balance in the booster model. Data were also obtained with the booster canard off in close proximity and for the launch configuration.

Plotted data for this test will be published under one data report number (DMS-DR-1108) with seven volumes as described below:

<u>Volume</u>	<u>Description</u>
I	Mach Number 5 Booster Proximity Data
II	Mach Number 5 Orbiter Proximity Data
III	Mach Number 3 Booster Proximity Data
IV	Mach Number 3 Orbiter Proximity Data
V	Mach Number 2 Booster Proximity Data
VI	Mach Number 2 Orbiter Proximity Data
VII	Interference Free Data for Orbiter and Booster, Launch Vehicle Data, and Proximity Data for Mach Numbers 4 and 6

A report containing Schlieren photographs will be published by AEDC. Schlieren photographs were taken at  $-10$ ,  $0$ , and  $10$  degrees angles of attack for each pitch polar.

THIS PAGE INTENTIONALLY LEFT BLANK

TABLE OF CONTENTS

	<u>PAGE</u> <u>NUMBER</u>
ABSTRACT .....	1
LIST OF FIGURES AND TABLES .....	2
SUMMARY .....	3
NOMENCLATURE SUMMARY .....	4
CONFIGURATIONS INVESTIGATED .....	5
NOZZLE CALIBRATIONS .....	6
TEST PROCEDURE .....	8
DATASET COLLATIONS .....	10
TEST FACILITY DESCRIPTION .....	63
TEST CONDITIONS .....	64
DATA REDUCTION .....	70
SUMMARY DATA PLOT INDEX .....	74
FIGURES .....	75
MODEL COMPONENT DESCRIPTION SHEETS .....	87
NOMENCLATURE .....	96
ADDITIONS AND CHANGES TO NOMENCLATURE .....	101
REFERENCES .....	103
TABULATED DISPLAY LISTING .....	104
PLOTTED DATA .....	105

## LIST OF FIGURES AND TABLES

Figure	Title	Page
1	Axis Systems . . . . .	76
2	Separation Nomenclature and Moment Reference Points . . . . .	77
3	General Arrangement of Models in Tunnel . . . . .	78
4	Modifications to Orbiter Model . . . . .	79
5	Modifications to Booster Model . . . . .	80
6	Photograph of Booster and Orbiter Sting-Nozzle Hardware . . . . .	81
7	Photograph of Booster Nozzle Hardware . . . . .	82
8	Photograph of Orbiter Nozzle Hardware . . . . .	83
9	Photograph of MDAC Booster and Orbiter Models . . . . .	84
10	Photograph of Side View of Models and Separation Hardware . . . . .	85
11	Photograph of Top View of Models and Associated Separation Hardware . . . . .	86
Table	Title	Page
I	SADSAC Nomenclature of Aerodynamic Coefficients. . . . .	4

## SUMMARY

This report presents aerodynamic data obtained from a joint Langley Research Center (LaRC)/Marshall Space Flight Center (MSFC) Space Shuttle abort stage separation wind tunnel test. The .00556 scale models of the McDonnell-Douglas orbiter and booster configurations were tested in close proximity using dual balances in Tunnel A of the Von Karman Facility (VKF), Arnold Engineering Development Center (AEDC) during the time period of April 21 to April 27, 1971. Data were obtained for both booster and orbiter over an angle of attack range from  $-10^{\circ}$  to  $10^{\circ}$  for zero degree sideslip angle. The models were tested at several relative incidence angles and separation distances and power conditions. Plug nozzles utilizing air were used to simulate booster and orbiter plumes at various altitudes along a nominal ascent trajectory. Powered conditions were 100, 50, 25 and 0 percent of full power for the orbiter and 100, 50 and 0 percent of full power for the booster. Pitch control effectiveness data were obtained for both booster and orbiter with power on and off. In addition, launch vehicle data with and without booster power were obtained utilizing a single balance in the booster model. Data were also obtained with the booster canard off in close proximity and for the launch configuration.

Plotted data for this test will be published under one data report number (DMS-DR-1108) with seven volumes as described below:

<u>Volume</u>	<u>Description</u>
I	Mach Number 5 Booster Proximity Data
II	Mach Number 5 Orbiter Proximity Data
III	Mach Number 3 Booster Proximity Data
IV	Mach Number 3 Orbiter Proximity Data
V	Mach Number 2 Booster Proximity Data
VI	Mach Number 2 Orbiter Proximity Data
VII	Interference Free Data for Orbiter and Booster, Launch Vehicle Data, and Proximity Data for Mach Numbers 4 and 6.

A report containing Schlieren photographs will be published by AEDC. Schlieren photographs were taken at  $-10^{\circ}$ ,  $0^{\circ}$ , and  $10^{\circ}$  angles of attack for each pitch polar.



TABLE I. SADSAC NOMENCLATURE OF AERODYNAMIC COEFFICIENTS

COEFFICIENT	COEFFICIENT NAME	SADSAC NOMENCLATURE		
		BODY AXIS	STABILITY AXIS	WIND AXIS
C <sub>A</sub>	Total Axial Force	CA	-	-
C <sub>AB</sub>	Base Axial Force	CAB	--	-
C <sub>AF</sub>	Forebody Axial Force	CAF	-	-
C <sub>D</sub>	Total Drag Force	-	CD	CDTOTL
C <sub>DB</sub>	Base Drag Force	-	CDB	CDBASE
C <sub>DF</sub>	Forebody Drag Force	-	CDF	CDFORE
C <sub>L</sub>	Lift Force	-	CL	CL
C <sub>N</sub>	Normal Force	CN	-	-
C <sub>Y</sub>	Side Force	CY	CY	CC
C <sub>l</sub>	Rolling Moment	CBL	CSL	CWL
C <sub>m</sub>	Pitching Moment	CLM	CLM	CPM
C <sub>n</sub>	Yawing Moment	CYN	CLN	CLN
L/D	Lift-To-Drag Force Ratio	-	L/D	CL/CD
L/D	Lift-To-Forebody Drag Force Ratio	-	L/DF	CL/CDF
N/A	Normal-To-Axial Force Ratio	N/A	-	-
N/A	Normal-To-Forebody Axial Force Ratio	CN/CAF	-	-

## CONFIGURATIONS INVESTIGATED

The two configurations tested were the MDAC orbiter and booster, figures 4 and 5 respectively. The orbiter is basically the configuration illustrated on MDAC drawing number 255BJ0050. Modifications made on the orbiter to allow for installation of the nozzle assembly is shown in figure 4.

The booster configuration is basically the configuration designated 19A by MDAC (drawing number 256-19-0001). The body, wing, and canard of the booster model are that of configuration 19A except that the body does not have a base flare or boattail, figure 5. The vertical tails are those which were designed for the configuration designated 17 (drawing number 256-17-001).

Both the orbiter and booster models had moveable elevons with deflection angles of  $0^\circ$ ,  $\pm 10^\circ$ , and  $\pm 20^\circ$ . Geometric characteristics are shown on the following pages. Figures 4, 5, and 6 are photographs showing both models and models with associated separation hardware. Figures 5 and 6 also show the trip strip installation. For Mach 5 a grit size of #26 was utilized. However, at the beginning of the test a grit sizing study was performed which showed a slight effect on  $C_A$  only.

## NOZZLE CALIBRATION

Two plug nozzle systems were designed and fabricated to simulate the rocket exhaust plume emitting from the booster and orbiter main propulsion systems during staging. Each nozzle was designed based on the gasdynamic simulation parameters established in Ref. 1. A variable area ratio capability was incorporated into both nozzle systems to permit the proper gasdynamic simulation of the full scale rocket exhaust plume at the various trajectory conditions of interest. Photographs of the nozzle hardware are shown in figures 6, 7 and 8.

### Nozzle Calibration Test Objectives

The objectives of the nozzle calibration test were:

- o Establish, experimentally, nozzle performance characteristics for the range of area ratio settings to be used with the booster and orbiter nozzles, respectively.
- o Establish the degree of plume simulation obtained with the booster and orbiter nozzles, respectively.
- o Establish a curve (based on experimental results) of nozzle exit conditions as a function of nozzle area ratio setting.

### Nozzle Calibration

Calibration testing of the booster and orbiter plug nozzles was accomplished in Tunnel C of the Arnold Engineering Development Center's Von Karman Gas Dynamics Facility. The nozzles were tested individually at a series of area ratio settings. Nozzle operating conditions (chamber pressure,  $P_{0j}$ ; and chamber

temperature,  $T_{Oj}$ ) were maintained in a range compatible with the abort staging test conditions. A quiescent low pressure,  $P_b$ , condition was maintained in the test cell. Data recorded at each area ratio setting included: optical data to determine plume shapes; static pressure measurements on the sting surface at the nozzle exit; nozzle mass flow measurements; and pitot pressure surveys in the plume at several locations downstream of the nozzle exit plane. The various test parameters sampled at each setting were correlated during the data evaluation to establish actual nozzle performance characteristics.

In a parallel effort, analytical solutions of the nozzle flow field and associated plume were generated for various area ratio settings of the booster and orbiter models. A method of characteristics solution employing real gas thermodynamic data for air was utilized in the calculations. Analytical results for each area ratio setting included: plume shape; static pressure distribution along sting surface; and plots of constant Mach number and constant pitot pressure contours in the plume flow field. These results formed a baseline for evaluating the experimentally measured performance of the plug nozzles.

A detailed evaluation of the calibration test results has been prepared and presented in Reference 2. Included in this reference are curves relating experimentally measured nozzle performance to nozzle area ratio settings for both booster and orbiter. These curves were utilized to set the correct nozzle area ratio for exhaust plume gasdynamic simulations during the test.

## TEST PROCEDURE

Abort staging was simulated by movement of the orbiter model through a matrix of points in the booster model flow field. Vertical and axial translation of the orbiter model was provided by an electrically driven remotely controlled positioning mechanism. The general arrangement of the models in the tunnel is shown in figure 3. The orbiter positioning mechanism and the booster model support were attached to the wind tunnel angle of attack system which provided +10-degree angle of attack variation for the booster-orbiter combination. Incidence angle variation was provided by manual adjustment of the orbiter sting.

The orbiter positioning mechanism provided axial translation of approximately 17 inches and vertical translation of approximately 15 inches with respect to the booster. An automatic control system allowed a series of positions to be programmed prior to a test run. The control system had provisions for 25 different x-positions and 25 different z-positions. For these tests, however, only 9 x-positions and 8 z positions were utilized. All x and z positions except the first and last could be switched in or out of the matrix as desired.

The automatic positioning mechanism was slaved to the angle of attack mechanism so that as a pitch sweep was completed the positioning mechanism

was released to advance to the next matrix point and as the point was reached the angle of attack mechanism was released for a pitch sweep. The entire matrix was covered in this manner and about 30 seconds were required for each pitch sweep in the matrix.

Plume simulation was provided by a single torodial nozzle in each model. The nozzles were designed with variable area ratio capability to permit proper simulation of the full-scale rocket plume at the various trajectory conditions of interest. Pretest calibration of the nozzles was used to correlate area ratio settings with measured plume shapes, nozzle mass flow, and nozzle exit static pressure. Air heated to approximately 100°F was supplied to the nozzles, and separate controls for the booster and orbiter supplies were provided.

TEST VA 1163 DATA SET COLLATION SHEET

10

PRETEST  
 POSTTEST

DATA SET IDENTIFIER	CONFIGURATION	SCHD.		PARAMETERS/VALUES								No. of Runs	DELTA Z/°B							
		α	β	PWR	PWR AX/°	α <sub>1</sub>	M <sub>0</sub>	δ <sub>01</sub>	δ <sub>02</sub>	.119	.151		.182	.228	.352	.579	.908	10.0		
RT8001	MDAC BOOSTER	A	0	0.0	0.0	-.391	0.0	5.0	0.0	0.0	8	301	318	319	338	339	354	355	555	
002						-.143					8	302	317	320	337	340	353	356		
003						-.019					8	303	316	321	336	341	352	357		
004						.043					6	304	315	322	335	342				
005						.105					8	305	314	323	333	343	351	358		
006						.167					6	306	313	324	332	344				
007						.228					8	307	312	325	331	345	350	359		
008						.351					8	308	311	326	330	346	349	360		
009						.522					8	309	310	327	328	347	348	361	Y	
010						-.31	5.1				6	601	618	619	636	637			637	
011						-.143					6	602	617	620	635	638				
012						-.019					5	603	616	621	634					
013						.043					5	604	615	622	633					
014						.105					6	605	614	623	632	639				
015						.167					5	606	613	624	631					
016						.228					5	607	612	625	630					
017						.351					5	608	611	626	629					
018						.522					6	609	610	627	628	640			Y	

1            7            13            19            25            31            37            43            49            55            61            67            7576

ALPHA DELTA    ICM    ICA    IGBL    IGY    CYN    DELTA Z    7

COEFFICIENTS: \_\_\_\_\_ IDPVAR(1) | IDPVAR(2) | NDV

α or β            A = -10° to +10° ONE DATA POINT PER DEGREE

SCHEDULES \_\_\_\_\_

TEST VA 1163 DATA SET COLLATION SHEET

PRETEST  
 POSTTEST

DATA SET IDENTIFIER	CONFIGURATION	SCHED.		PARAMETERS/VALUES							No. of Runs	DELTA Z/R										
		a	B	PWR	PWR	ALFA	alpha	M <sub>0</sub>	delta <sub>0</sub>	delta <sub>0</sub>		.119	.151	.182	.222	.352	.599	908	10.0			
RT8 019	MDAC BOOSTER	A	0	0.0	0.0	-.591	10.1	5.0	0.0	0.0	5				1101	1118	1119	1131			1131	
020						-.113					5				1102	1117	1120	1130				
021						-.219					4				1103	1116	1121					
022						.043					4				1104	1115	1122					
023						.105					5				1105	1114	1123	1129				
024						.167					4				1106	1113	1124					
025						.228					4				1107	1112	1125					
026						.351					4				1108	1111	1126					
027						.501					5				1109	1110	1127	1121			Y	
028						-.391	-4.9				7	741	701	718	719	736	737				737	
029						-.113					7	743	702	717	720	735	738					
030						-.049					6	744	703	716	721	734						
031						.043					6	745	704	715	722	733						
032						.105					7	746	705	714	723	732	739					
033						.167					6	747	706	713	724	731						
034						.228					6	748	707	712	725	730						
035						.351					6	749	708	711	726	729						
036						.522					7	750	709	710	727	724	740					Y

1      7      13      19      25      31      37      43      49      55      61      67      7576

ALPHA   QCLM   ICH   ICR   ICBL   CY   CYN   DELTAZ   7

COEFFICIENTS: \_\_\_\_\_ [IDPVAR(1)] IDPVAR(2) NDV

a or B      A = -10° to +10° ONE DATA POINT PER DEGREE

SCHEDULES \_\_\_\_\_



PRETEST  
 POSTTEST

DATA SET IDENTIFIER	CONFIGURATION	SCHD.		PARAMETERS/VALUES						No. of Runs	DELTA Z/4 <sub>p</sub>								
		α	β	PWR	PWR	ΔX/A	α <sub>z</sub>	M <sub>0</sub>	δ <sub>0P</sub>		δ <sub>0D</sub>	.119	.151	.182	.228	.352	.599	.908	10.0
RT8 037	MDAC BOOSTER	A	0	50.	100.	.391	0.0	5.0	0.0	0.0	8	401	418	419	436	437	453	454	454
038						.143					8	402	417	420	435	438	452	455	
039						.019					8	403	416	421	434	439	451	456	
040						.043					6	404	415	422	433	440			
041						.105					8	405	414	423	432	441	450	457	
042						.167					6	406	413	424	431	442			
043						.228					8	407	412	425	430	443	449	458	
044						.351					8	408	411	426	429	444	447	459	
045						.522	Y				8	409	410	427	42	445	446	460	Y
046						.391	5.1				6	501	518	519	536	537		537	
047						.143					6	502	517	520	535	538			
048						.019					5	503	516	521	534				
049						.043					5	504	515	522	533				
050						.105					6	505	514	523	532	539			
051						.167					5	506	513	524	531				
052						.228					5	507	512	525	530				
053						.351					5	508	511	526	529				
054						.522	Y	Y	Y	Y	6	509	510	527	528	540			Y

1            7            13            19            25            31            37            43            49            55            61            67            7576

ALPHA CLM    IGM    ICA    ICBL    ICY    ICYN    DELTA Z    7

COEFFICIENTS:    A = -10° + 0 + 10° ONE DATA POINT PER DEGREE    IDPVAR(1) | IDPVAR(2) | NDV

α or β

SCHEDULES

TEST VA 1163 DATA SET COLLATION SHEET

PRETEST  
 POSTTEST

DATA SET IDENTIFIER	CONFIGURATION	SCHED.		PARAMETERS/VALUES							No. of Runs	DELTA Z/R								
		α	β	PWR	PWR	ΔX/R	α <sub>2</sub>	M <sub>0</sub>	δ <sub>01</sub>	δ <sub>02</sub>		.119	.151	.182	.228	.352	.599	.908	10.0	
RT8055	MDAC B4DSTER	A	Q	50.	100.	-.391	10:1	5.0	0.0	0.0	5				1001	1019	1020	1032		1052
056						-.43					5				1022	1018	1021	1031		
057						-.019					4				1003	1017	1022			
058						.043					4				1004	1016	1023			
059						.105					5				1005	1015	1024	1030		
060						.167					4				1006	1014	1025			
061						.228					4				1007	1022	1026			
062						.351					4				1008	1011	1027			
063						.501					5				1009	1010	1028	1029		↓
064						-.391	-5.0				7	801	818	819	837	838	850			850
065						-.43					7	802	817	820	836	839	849			
066						-.019					6	803	816	821	835	840				
067						.043					6	804	815	822	834	841				
068						.105					7	805	814	823	833	842	848			
069						.167					6	806	813	824	832	843				
070						.228					6	807	812	825	831	844				
071						.351					6	808	811	827	830	845				
072						.502					7	809	810	828	829	846	847			↓

1      7      13      19      25      31      37      43      49      55      61      67      75 76

ALPHA    CLM    ICN    ICA    ICBL    CY    CYN    DELTA    7

COEFFICIENTS: \_\_\_\_\_ > |XDPVAR(1)| XDPVAR(2) |NDV

α or β      A = -10° TO +10° ONE DATA POINT PER DEGREE

SCHEDULES \_\_\_\_\_

PRETEST  
 POSTTEST

DATA SET IDENTIFIER	CONFIGURATION	SCHD.		PARAMETERS/VALUES						No. of Runs	DELTA Z/2R								
		A	B	PWR	PWR	AX/PA	A	M <sub>0</sub>	δ <sub>0</sub>		δ <sub>0</sub>	.119	.151	.182	.228	.352	.599	.908	10.0
RT8 073	MDAC BOOSTER	A	0	50.	100.	-791	-10.1	5.0	0.0	0.0	5			1201	1218	1219	1231		1251
074						-143					5			1202	1217	1220	1230		
075						-209					4			1203	1216	1221			
076						.043					4			1204	1215	1222			
077						.105					5			1205	1217	1223	1229		
078						.167					4			1206	1213	1224			
079						.228					4			1207	1212	1225			
080						.351					4			1208	1211	1226			
081				Y	Y	.522	Y				5			1209	1210	1227	1228		Y
082				0.0	0.0	-391	0.0				4	201	208	209	216				
083						-143					4	202	207	210	215				
084						.105					4	203	206	211	214				
Y 085	Y	Y	Y	Y	Y	.522	Y	Y	Y	Y	4	204	205	212	213				

1            7            13            19            25            31            37            43            49            55            61            67            75 76

A L P H A D C L M    I C N    I C A    I C B L    I C X    C Y N    D E L T A Z    7

COEFFICIENTS: \_\_\_\_\_ IDPVAR(1) IDPVAR(2) NDV  
 A = -10° to +10° ONE DATA POINT PER DEGREE  
 α or β \_\_\_\_\_  
 SCHEDULES \_\_\_\_\_

TEST VA 1163 DATA SET COLLATION SHEET

PRETEST  
 POSTTEST

DATA SET IDENTIFIER	CONFIGURATION	SCHD.		PARAMETERS/VALUES							No. of Runs	DELTA Z/B													
		A	B	PWR	PWR	AX/A	$\alpha$	M <sub>0</sub>	$\delta\alpha$	$\delta\beta$		.119	.151	.182	.228	.352	.599	.908	10.0						
RT3086	MDFC BOOSTER	A	D	100	100	-.391	0.0	5.0	0.0	0.0	6	1301	1314	1315	1328	1329								1334	
087						-.143					6	1302	1313	1316	1327	1330									
088						-.019					5	1303	1312	1317	1326										
089						.105					6	1304	1311	1318	1325	1331									
090						.167					5	1305	1310	1319	1324										
091						.351					6	1306	1309	1320	1323	1332									
092						.522	Y				6	1307	1308	1321	1322	1333									Y
093						-.391	5.0				5		1501	1514	1515	1526									1527
094						-.143					5		1502	1513	1516	1525									
095						-.019					4		1503	1512	1517										
096						.105					5		1504	1511	1518	1524									
097						.167					4		1505	1510	1519										
098						.351					5		1506	1509	1520	1523									
099						.522	Y				5		1507	1508	1521	1522									Y

1            7            13            19            25            31            37            43            49            55            61            67            75 76

ALPHA    DELTA    M    ICB    ICB    ICB    CY    CY    DELTA    T

COEFFICIENTS: A = -10° TO +10° ONE DATA POINT PER DEGREE → [IDFVAR(1)] [IDFVAR(2)] [NDV]

$\alpha$  or  $\beta$  \_\_\_\_\_

SCHEDULES \_\_\_\_\_

PRETEST  
 POSTTEST

DATA SET IDENTIFIER	CONFIGURATION	SCHD.		PARAMETERS/VALUES							No. of Runs	DELTA Z/deg							
		α	β	PWR	PWR	AX/β	α	M <sub>0</sub>	δ <sub>0</sub>	δ <sub>0</sub>		.119	.151	.182	.228	.352	.599	.90P	10.0
RT8 100	NDAC BOOSTER	A	0	0.0	100.	-.391	0.0	5.0	0.0	0.0	5	1401	1414	1415	1428				355
101						-.143					5	1402	1413	1416	1427				
102						-.019					5	1403	1412	1417	1426				
103						.105					5	1404	1411	1418	1425				
104						.167					5	1405	1410	1419	1424				
105						.351					5	1406	1409	1420	1423				
106				Y	Y	.522					5	1407	1408	1421	1422				Y
107				50.	50.	-.391					6	1801	1814	1815	1828	1829			1834
108						-.143					6	1802	1813	1816	1827	1830			
109						-.019					5	1803	1812	1817	1826				
110						.105					6	1804	1811	1818	1825	1831			
111						.167					5	1805	1810	1819	1824				
112						.351					6	1806	1809	1820	1823	1832			
113				Y	Y	.522				Y	6	1807	1808	1821	1822	1833			Y

1            7            13            19            25            31            37            43            49            55            61            67            7576

ALPHA C L M    ICN    ICA    ICB    ICY    CYN    DELTA B    9

COEFFICIENTS: \_\_\_\_\_ IDPVAR(1) IDPVAR(2) NDV  
 α or β    A = -10° to +10° ONE DATA POINT PER DEGREE  
 SCHEDULES \_\_\_\_\_  
 \_\_\_\_\_

TEST VA 1163 DATA SET COLLATION SHEET

PRETEST  
 POSTTEST

DATA SET IDENTIFIER	CONFIGURATION	SCHD.		PARAMETERS/VALUES							No. of Runs	DELTA Z/δ <sub>B</sub>							
		α	β	PWR	PWR	ΔL	ΔL	α <sub>i</sub>	M <sub>∞</sub>	δ <sub>∞</sub>		δ <sub>∞</sub>	.119	.151	.182	.228	.352	.579	.908
RT8 114	MDAC BOOSTER	A	0	50.	50.	-.391	5.0	5.0	0.0	0.0	5	1601	1614	1615	1626				1627
115						-.142					5	1602	1613	1616	1625				
116						-.019					4	1603	1612	1617					
117						.105					5	1604	1611	1618	1624				
118						.167					4	1605	1610	1619					
119						.351					5	1606	1609	1620	1623				
120						.522					5	1607	1608	1621	1622				
121				50.	25.	-.391					3	1701	1714						
122						-.142						1702	1713						
123						-.019						1703	1712						
124						.105						1704	1711						
125						.167						1705	1710						
126						.351						1706	1709						
127						.522						1707	1708						

1      7      13      19      25      31      37      43      49      55      61      67      75 76

ALPHA ΔCLM    ICM    ICR    ICBL    IY    IYN    DELTA B    7

COEFFICIENTS: \_\_\_\_\_ → IDPVAR(1) IDPVAR(2) NDV

α or β      A = -10° to +10° ONE DATA POINT PER DEGREE

SCHEDULES \_\_\_\_\_

TEST VA 1163 DATA SET COLLATION SHEET

PRETEST

POSTTEST

DATA SET IDENTIFIER	CONFIGURATION	SCHED.		PARAMETERS/VALUES						No. of Runs	DELTA Z/°R							
		α	β	PWR	PWR	AX/°	α	M <sub>∞</sub>	Seq		Seq	.119	.151	.182	.228	.352	.599	.908
RT8 128	MDAC BOOSTER	A	0	0.0	0.0	-.391	0.0	5.0	20.	-20.	6	1901	1914	1915	1928	1929		1924
129						-.143					6	1902	1913	1916	1927	1930		
130						-.019					5	1903	1912	1917	1926			
131						.105					6	1904	1911	1918	1925	1931		
132						.167					5	1905	1910	1919	1924			
133						.351					6	1906	1909	1920	1923	1932		
134				↓	↓	.522					6	1907	1908	1921	1922	1935		↓
135						100. 100. -.391					3	2001	2014	2015				
136						-.143					3	2002	2013	2016				
137						-.09					3	2003	2012	2017				
138						.105					2	2004	2011					
139						.167					2	2005	2010					
140						.351					2	2006	2009					
141		↓	↓	↓	↓	.522	↓	↓	↓	↓	2	2007	2008					

1          7          13          19          25          31          37          43          49          55          61          67          75 76

ALPHA CLM    ICH    ICA    ICBL    CY    CYN    DELTA    7

COEFFICIENTS:    A = -10° TO +10° ONE DATA POINT PER DEGREE    IDPVAR(1) IDPVAR(2) NDV

α or β  
SCHEDULES

TEST VA 1163 DATA SET COLLATION SHEET

19

PRETEST  
 POSTTEST

DATA SET IDENTIFIER	CONFIGURATION	SCHED.		PARAMETERS/VALUES							No. of Runs	DELTA Z/δ <sub>R</sub>							
		α	β	PWR	PWR	AX/L	α <sub>z</sub>	M <sub>∞</sub>	δ <sub>EP</sub>	δ <sub>ED</sub>		.119	.151	.182	.228	.352	.599	.908	10.0
RT8 142	MDAC ORBITER	A	0	0.0	0.0	-.391	0.0	5.0	0.0	0.0	8	301	318	319	338	339	354	355	361
143						-.143					8	302	317	320	337	340	353	356	
144						-.219					8	303	316	321	336	341	352	357	
145						.043					6	304	315	322	335	342			
146						.105					8	305	314	323	333	343	351	358	
147						.167					6	306	313	324	332	344			
148						.228					8	307	312	325	331	345	350	359	
149						.351					8	308	311	326	330	346	349	360	
150						.522					8	309	310	327	328	347	348	361	✓
151						-.391	5.1				6	601	618	619	636	637		640	
152						-.143					6	602	617	620	635	638			
153						-.219					5	603	616	621	634				
154						.043					5	604	615	622	633				
155						.105					6	605	614	623	632	639			
156						.167					5	606	613	624	631				
157						.228					5	607	612	625	630				
158						.351					5	608	611	626	629				
159						.522					6	609	610	627	628	640			✓

1      7      13      19      25      31      37      43      49      55      61      67      75 76

ALPHA DELTA    ICM    ICA    ICR L    CY    CYN    DELTA    7

COEFFICIENTS:    A = -10° to +10° ONE DATA POINT PER DEGREE    IDPVAR(1) IDPVAR(2) NDV

α or β

SCHEDULES



TEST VA 1163 DATA SET COLLATION SHEET

PRETEST  
 POSTTEST

DATA SET IDENTIFIER	CONFIGURATION	SCHD.		PARAMETERS/VALUES							No. of Runs	DELTA Z/L <sub>R</sub>							
		α	β	PWR	PWR	AX/L <sub>R</sub>	α	M <sub>0</sub>	δ <sub>01</sub>	δ <sub>02</sub>		.119	.151	.182	.222	.352	.599	.908	10.0
RT8160	MDAC CRITER	A	0	0.0	0.0	-.391	10.1	5.0	0.0	0.0	5				1101	1118	1119	1131	1128
161						-.143					5				1102	1117	1120	1130	
162						-.219					4				1103	1116	1121		
163						.043					4				1104	1115	1122		
164						.105					5				1105	1114	1123	1129	
165						.167					4				1106	1113	1124		
166						.228					4				1107	1112	1125		
167						.351					4				1108	1111	1126		
168						.501					5				1109	1110	1127	1128	Y
169						-.391	-4.9				7	741	701	718	719	736	737		740
170						-.143					7	743	702	717	720	735	738		
171						-.219					6	744	703	716	721	734			
172						.043					6	745	704	715	722	733			
173						.105					7	746	705	714	723	732	739		
174						.167					6	747	706	713	724	731			
175						.228					6	748	707	712	725	730			
176						.351					6	749	708	711	726	729			
177						.52					7	750	709	710	727	728	740		Y

1            7            13            19            25            31            37            43            49            55            61            67            75 76

ALPHA, CLM, ICN, ICA, ICB, CY, CYH, DELTA, 7

COEFFICIENTS:  $A = -10^\circ$  TO  $+10^\circ$  ONE DATA POINT PER DEGREE → [IDPVAR(1)] [IDPVAR(2)] [NDV]

α or β

SCHEDULES

TEST VA 1163 DATA SET COLLATION SHEET

12

PRETEST  
 POSTTEST

DATA SET IDENTIFIER	CONFIGURATION	SCHD.		PARAMETERS/VALUES						No. of Runs	DELTA Z/2R								
		α	β	PWR	PWR	AX/A	α	M <sub>0</sub>	δ <sub>α</sub>		δ <sub>β</sub>	.119	.151	.182	.228	.352	.599	.908	10.0
RT8178	NIDAC ORRETER	A	0	50.	100.	-.391	0.0	5.0	0.0	0.0	8	401	410	419	436	437	453	454	460
179						-.143					8	402	417	420	435	438	452	455	
180						-.019					8	403	416	421	434	439	451	456	
181						.043					6	404	415	422	433	440			
182						.105					8	405	414	423	432	441	450	457	
183						.167					6	406	413	424	431	442			
184						.228					8	407	412	425	430	443	449	458	
185						.351					8	408	411	426	429	444	447	459	
186						.522	Y				8	409	410	427	428	445	446	460	Y
187						-.391	5.1				6	501	518	519	536	537			540
188						-.143					6	502	517	520	535	538			
189						-.019					5	503	516	521	534				
190						.043					5	504	515	522	533				
191						.105					6	505	514	523	532	539			
192						.167					5	506	513	524	531				
193						.228					5	507	512	525	530				
194						.351					5	508	511	526	529				
195	Y	Y	Y	Y	Y	.522	Y	Y	Y	Y	6	509	510	527	528	540			Y

1 7 13 19 25 31 37 43 49 55 61 67 7576

ALPHA CLM : ICH ICA ICBL IGY GYN DELTAE 7

COEFFICIENTS: AE -10° to +10° ONE DATA POINT PER DEGREE → IDPVAR(1) IDPVAR(2) NDV

α or β \_\_\_\_\_

SCHEDULES \_\_\_\_\_

PRETEST  
 POSTTEST

DATA SET IDENTIFIER	CONFIGURATION	SCHD.		PARAMETERS/VALUES							No. of Runs	DELTA Z/ΔR							
		α	β	PWR	PWR	ΔX/Δ	α <sub>z</sub>	M <sub>00</sub>	δ <sub>0A</sub>	δ <sub>0B</sub>		.119	.151	.182	.228	.352	.599	.901	10.0
RT8 196	MIDAC FUTURESA	A	0	50.	100.	-.391	10.1	5.0	0.0	0.0	5			1001	1019	1020	1032		1029
197						-.143					5			1002	1018	1021	1031		
198						-.019					4			1003	1017	1022			
199						.043					4			1004	1016	1023			
200						.105					5			1005	1015	1024	1030		
201						.167					4			1006	1014	1025			
202						.228					4			1007	1012	1026			
203						.351					4			1008	1011	1027			
204						.501	Y				5			1009	1010	1028	1029		Y
205						-.391	-5.0				7	801	818	819	837	838	850		847
206						-.143					7	802	817	820	836	839	849		
207						-.019					6	803	816	821	835	840			
208						.043					6	804	815	822	834	841			
209						.105					7	805	814	823	833	842	848		
210						.167					6	806	813	824	832	843			
211						.228					6	807	812	825	831	844			
212						.351					6	808	811	827	830	845			
Y 213	Y	Y	Y	Y	Y	.522	Y	Y	Y	Y	7	809	810	828	829	846	847		Y

1            7            13            19            25            31            37            43            49            55            61            67            75 76

ALPHA QCLM    ICM    ICA    ICBL    CY    CYN    DELTA    7

COEFFICIENTS:    A = -10° TO +10° ONE DATA POINT PER DEGREE    IDPVAR(1) IDPVAR(2) NDV

α or β

SCHEDULES

TEST VA 1163 DATA SET COLLATION SHEET

23

PRETEST

POSTTEST

DATA SET IDENTIFIER	CONFIGURATION	SCHD.		PARAMETERS/VALUES							No. of Runs	DELTA Z/°B							
		A	B	PWR	PWR	ΔX/ΔY	α <sub>i</sub>	M <sub>00</sub>	δ <sub>0R</sub>	δ <sub>0D</sub>		.119	.151	.182	.222	.352	.599	.902	10.0
RTB 214	MBAC GREATER	A	0	50.	100.	-.391	-10.1	5.0	0.2	0.0	5			1201	1218	1219	1231		1222
215						-.143					5			1202	1217	1220	1230		
216						-.018					4			1203	1216	1221			
217						.043					4			1204	1215	1222			
218						.105					5			1205	1217	1223	1229		
219						.167					4			1206	1213	1224			
220						.228					4			1207	1212	1225			
221						.351					4			1208	1211	1226			
222				Y	Y	.522	Y				5			1209	1210	1227	1228		Y
223						0.0	0.0	-.391	0.0		4	201	208	209	216				
224						-.143					4	202	207	210	215				
225						.105					4	203	206	211	214				
226		Y	Y	Y	Y	.522	Y	Y	Y	Y	4	204	205	212	213				

1                    7                    13                    19                    25                    31                    37                    43                    49                    55                    61                    67                    75 76

ALPHA/CLM    ICA    ICB    ICL    ICM    ICN    DELTA    7

COEFFICIENTS:    A = -10° TO +10° ONE DATA POINT PER DEGREE    IDPVAR(1) IDPVAR(2) INDV

α or β

SCHEDULES

PRETEST

POSTTEST

DATA SET IDENTIFIER	CONFIGURATION	SCHD.		PARAMETERS/VALUES						No. of Runs	DELTA Z/Δ <sub>B</sub>							
		α	β	PWR	PWR	ΔX/Δ <sub>B</sub>	α	M <sub>0</sub>	δ <sub>0A</sub>		δ <sub>0B</sub>	.119	.151	.182	.227	.352	.599	.908
RT8 227	NDIC MONITOR	A	D	100	100	-.391	0.0	5.0	0.0	0.0	6	1301	1314	1315	1328	1329		1321
228						-.143					6	1302	1313	1316	1327	1330		
229						-.019					5	1303	1312	1317	1326			
230						.105					6	1304	1311	1318	1325	1331		
231						.167					5	1305	1310	1319	1324			
232						.351					6	1306	1309	1320	1323	1332		
233						.522	Y				6	1307	1308	1321	1322	1333		
234						-.391	5.0				5	1501	1514	1515	1526		1527	
235						-.112					5	1502	1513	1516	1525			
236						-.019					4	1503	1512	1517				
237						.105					5	1504	1511	1518	1524			
238						.167					4	1505	1510	1519				
239						.351					5	1506	1509	1520	1523			
240						.522	Y				5	1507	1508	1521	1522			

1            7            13            19            25            31            37            43            49            55            61            67            7576

ALPHA    CLM    ICN    ICA    ICRL    CY    CYN    DELTAZ    7

COEFFICIENTS:

α or β

SCHEDULES

A = -10° to +10° ONE DATA POINT PER DEGREE

IDPVAR(1) IDPVAR(2) NDV

TEST VA 1163 DATA SET COLLATION SHEET

PRETEST  
 POSTTEST

DATA SET IDENTIFIER	CONFIGURATION	SCHED.		PARAMETERS/VALUES							No. of Runs	DELTA Z/°B							
		α	β	PWR	PWR/AX/10	α	M <sub>0</sub>	δ <sub>ea</sub>	δ <sub>ep</sub>	.119		.157	.182	.228	.352	.599	.90P	10.0	
RT8 241	DIDAC CRSTER	A	0	0.0	100.	.391	0.0	5.0	0.0	0.0	5	1401	1414	1415	1428				460
242						-.443					5	1402	1413	1416	1427				
243						-.019					5	1403	1412	1417	1426				
244						.105					5	1404	1411	1418	1425				
245						.167					5	1405	1410	1419	1424				
246						.351					5	1406	1409	1420	1423				
247				Y	Y	.522					5	1407	1408	1421	1422				Y
248				50.	50.	-.391					6	1801	1814	1815	1828	1829			1834
249						-.443					6	1802	1813	1816	1827	1830			
250						-.019					5	1803	1812	1817	1826				
251						.105					6	1804	1811	1818	1825	1831			
252						.167					5	1805	1810	1819	1824				
253						.351					6	1806	1809	1820	1823	1832			
254				Y	Y	.522	Y	Y	Y	Y	6	1807	1808	1821	1822	1833			Y

1      7      13      19      25      31      37      43      49      55      61      67      75 76

ALPHA  CLM    ICA    ICB    ICBL    ICY    CYN    DELTA

COEFFICIENTS: A = -10° to +10° ONE DATA POINT PER DEGREE    IDPVAR(1) IDPVAR(2) NDV

α or β \_\_\_\_\_

SCHEDULES \_\_\_\_\_



TEST VA 1163 DATA SET COLLATION SHEET

12

PRETEST  
 POSTTEST

DATA SET IDENTIFIER	CONFIGURATION	SCHD.		PARAMETERS/VALUES							No. of Runs	DELTA Z/δ <sub>R</sub>							
		α	β	PWR	PWR	ΔX/Δ	α <sub>i</sub>	M <sub>0</sub>	δ <sub>0R</sub>	δ <sub>0D</sub>		.119	.151	.182	.228	.358	.599	.908	10.0
RTD 269	MDAC OBSITER	A	D	0.0	0.0	-.391	0.0	5.0	20.	-20.	6	1901	1914	1915	1928	1929		1934	
270						-.143					6	1902	1913	1916	1929	1930			
271						-.019					5	1903	1912	1917	1926				
272						.105					6	1904	1911	1918	1925	1931			
273						.167					5	1905	1910	1919	1924				
274						.351					6	1906	1909	1920	1923	1932			
275				↓	↓	.522					6	1907	1908	1921	1922	1935		↓	
276						100.100.	-.391				3	2001	2014	2015					
277						-.143					3	2002	2013	2016					
278						-.09					3	2003	2012	2017					
279						.105					2	2004	2011						
280						.167					2	2005	2010						
281						.351					2	2006	2009						
282				↓	↓	.522		↓	↓	↓	2	2007	2008						

1                    7                    13                    19                    25                    31                    37                    43                    49                    55                    61                    67                    7576

ALPHA CLM    ICA    ICB    ICBL    CY    CYN    DELTA    7

COEFFICIENTS:    \_\_\_\_\_    ITPVAR(1) | ITPVAR(2) | NDV

α or β    \_\_\_\_\_    A = -10° TO +10° ONE DATA POINT PER DEGREE

SCHEDULES    \_\_\_\_\_



PRETEST  
 POSTTEST

DATA SET IDENTIFIER	CONFIGURATION	SCHD.		PARAMETERS/VALUES							No. of Runs	DELTA Z/°R									
		a	B	PWR	PWR	AX/B	α	M <sub>0</sub>	δ <sub>0</sub>	δ <sub>0</sub>		.113	.119	.151	.182	.228	.352	.599	.900	10.0	
RTR 283	MDAC BOOSTER	A	0	0.0	0.0	.391	0.0	2.0	0.0	0.0	9	4201	3301	3318	3319	3336	3337	3352	3353	3353	
284						.143					9	4202	3302	3317	3320	3335	3338	3351	3354		
285						.019					8	4203	3303	3316	3321	3334	3339	3350			
286						.043					7	4204	3304	3315	3322	3333	3340				
287						.105					9	4205	3305	3314	3323	3332	3341	3349	3355		
288						.167					7	4206	3306	3313	3324	3331	3342				
289						.228					8	4207	3307	3312	3325	3330	3343	3348			
290						.351					8	4208	3308	3311	3326	3329	3344	3347			
291						.501	Y				9	4209	3309	3310	3327	3328	3345	3346	3356	Y	
292						.391	5.0				7		3501	3518	3519	3536				3353	
293						.143					7		3502	3517	3520	3535	3538				
294						.019					6		3503	3516	3521	3534					
295						.043					5		3504	3515	3522	3533					
296						.105					7		3505	3514	3523	3532					
297						.167					5		3506	3513	3524	3531					
298						.228					6		3507	3512	3525	3530					
299						.351					6		3508	3511	3526	3529					
300						.522	Y	Y	Y	Y	7		3509	3510	3527	3528	3543	3544	Y		

1                    7                    13                    19                    25                    31                    37                    43                    49                    55                    61                    67                    7576

ALPHA CLM    ICH    ISA    ICBL    CY    CYN    DELTA Z    7

COEFFICIENTS:    A = -10° TO +10° ONE DATA POINT PER DEGREE    IDPVAR(1) IDPVAR(2) NDV

α or β  
 SCHEDULES

TEST VA 1163 DATA SET COLLATION SHEET

62

PRETEST  
 POSTTEST

DATA SET IDENTIFIER	CONFIGURATION	SCHD.		PARAMETERS/VALUES						No. of Runs	DELTA Z/ΔR								
		α	β	PWR	PWR	AX/L	R:	M <sub>0</sub>	δ <sub>01</sub>		δ <sub>02</sub>	.119	.151	.182	.228	.352	.579	.908	10.0
ATB 301	MDAC BOOSTER	A	0	0.0	0.0	-.391	10.0	2.0	0.0	0.0	6			3801	3818	3819	3834	3835	3835
302						-.43					6			3802	3817	3820	3833	3836	
303						-.019					5			3803	3816	3821	3832		
304						.043					4			3804	3815	3822			
305						.105					6			3805	3814	3823	3831	3837	
306						.167					4			3806	3813	3824			
307						.228					5			3807	3812	3825	3830		
308						.351					5			3808	3811	3826	3829		
309						.501					6			3809	3810	3827	3828	3838	Y
310						-.391	-5.0				8	3701	3718	3719	3736	3737	3752	3753	3753
311						-.43					8	3702	3717	3720	3735	3738	3751	3754	
312						-.019					7	3703	3716	3721	3734	3739	3750		
313						.043					6	3704	3715	3722	3733	3740			
314						.105					8	3705	3714	3723	3732	3741	3749	3755	
315						.167					6	3706	3713	3724	3731	3742			
316						.228					7	3707	3712	3725	3730	3743	3748		
317						.351					7	3708	3711	3726	3729	3744	3747		
318						.501					8	3709	3710	3727	3728	3745	3746	3756	Y

1      7      13      19      25      31      37      43      49      55      61      67      75 76

ALPHADICLM    V.N    ICA    ICAL    IY    SYN    DELTAR    7

COEFFICIENTS:    A = -10° TO +10° ONE DATA POINT PER DEGREE    IDPVAR(1) IDPVAR(2) IDV

α or β

SCHEDULES

PRETEST

POSTTEST

DATA SET IDENTIFIER	CONFIGURATION	SCHD.		PARAMETERS/VALUES						No. of RUNS	DELTA Z/L <sub>R</sub>								
		α	β	PWR	PWR	AX/A	α	M <sub>0</sub>	δ <sub>0</sub>		δ <sub>0</sub>								
RT8319	MDAC BFDSTER	A	0	50.0	100.0	-391	0.0	2.0	0.0	0.0	7	3401	3418	3419	3436	3437	3452		34171
320						-143					8	3402	3417	3420	3435	3438	3451	3454	
321						-019					7	3403	3416	3421	3434	3439	3450		
322						.043					6	3404	3415	3422	3433	3440			
323						.105					8	3405	3414	3423	3432	3441	3449	3453	
324						.167					6	3406	3413	3424	3431	3442			
325						.228					7	3407	3412	3425	3430	3445	3448		
326						.351					7	3408	3411	3426	3429	3444	3447		
327						.522	↓				8	3409	3410	3427	3428	3445	3446	3450	↓
328						-391	5.0				7		3601	3618	3619	3636	3637	3647	3647
329						-143					7		3602	3617	3620	3635	3638	3646	
330						-019					6		3603	3616	3621	3634	3639		
331						.043					5		3604	3615	3622	3633			
332						.105					7		3605	3614	3623	3632	3640	3645	
333						.167					5		3606	3613	3624	3631			
334						.228					6		3607	3612	3625	3630	3641		
335						.351					6		3608	3611	3626	3629	3642		
336						.522	↓				7		3609	3610	3627	3628	3643	3644	↓

1                    7                    13                    19                    25                    31                    37                    43                    49                    55                    61                    67                    7576

ALPHA    CLM    ICN    ICA    ICBL    CY    CYN    DELTA    7

COEFFICIENTS:                    IDPVAR(1) | IDPVAR(2) | NDV

α or β                    A = -10° to 110° ONE DATA POINT PER DEGREE

SCHEDULES

TEST VA 1163 DATA SET COLLATION SHEET

PRETEST  
 POSTTEST

DATA SET IDENTIFIER	CONFIGURATION	SCHD.		PARAMETERS/VALUES								No. of Runs	DELTA Z/LR							
		α	β	PWR	PWR	AX/LR	α	M <sub>00</sub>	δ <sub>00</sub>	δ <sub>00</sub>	.119		.151	.182	.228	.352	.599	.908	10.0	
RTB337	MDAC BOOSTER	A	0	50.0	1000	.391	10.0	2.0	0.0	0.0	6				4001	4018	4019	4034	4035	4035
338						-.143					6				4002	4017	4020	4033	4036	
339						-.519					5				4003	4016	4021	4032		
340						.043					4				4004	4015	4022			
341						.165					6				4005	4014	4023	4031	4037	
342						.167					4				4006	4013	4024			
343						.228					5				4007	4012	4025	4030		
344						.351					5				4008	4011	4026	4029		
345				Y	Y	.501	Y				6				4009	4010	4027	4028	4038	Y
346				0.0	0.0	-.391	0.0				8	3901	3918	3919	3936	3937	3952	3953	3953	
347						-.143					8	3902	3917	3920	3935	3938	3951	3954		
348						-.019					7	3903	3916	3921	3934	3939	3950			
349						.043					6	3904	3915	3922	3933	3940				
350						.165					8	3905	3914	3923	3932	3941	3949	3955		
351						.167					6	3906	3913	3924	3931	3942				
352						.228					7	3907	3912	3925	3930	3943	3948			
353						.351					7	3908	3911	3926	3929	3944	3947			
354		Y	Y	Y	Y	.522	Y	Y	Y	Y	8	3909	3910	3927	3928	3945	3946	3956	Y	

1                    7                    13                    19                    25                    31                    37                    43                    49                    55                    61                    67                    7576

ALPHA CLM    ICN    ICA    ICBL    CY    ICYN    DELTA

COEFFICIENTS:    A = -10° to +10° ONE DATA POINT PER DEGREE    IDPVAR(1) IDPVAR(2) NDV

α or β  
 SCHEDULES

PRETEST  
 POSTTEST

DATA SET IDENTIFIER	CONFIGURATION	SCHED.		PARAMETERS/VALUES							No. of Runs	DELTA Z/LB							
		$\alpha$	$\beta$	PWR	PWR	AX/LB	$\alpha$	M <sub>0</sub>	Seg	Gap		.119	.151	.182	.228	.352	.579	.908	10.0
RTB 355	MPAC BOOSTER	A	0	0.0	0.0	-391	0.0	2.0	20.0	-20.0	8	4401	4414	4415	4429	4430	4441	4442	4443
356						-143					8	4402	4413	4416	4422	4431	4440	4443	
357						-079					6	4403	4412	4417	4437	4439			
358						.105					8	4404	4411	4418	4426	4432	4438	4444	
359						.167					5	4405	4410	4419	4424				
360						.351					7	4406	4409	4420	4423	4433	4436		
361				↓	↓	.522					8	4407	4408	4421	4422	4434	4435	4445	↓
362						50.0	1000	-391			8	4501	4518	4519	4537	4538	4553	4554	4554
363						-143					8	4502	4517	4520	4536	4539	4552	4555	
364						-079					7	4503	4516	4521	4535	4540	4551		
365						.043					6	4504	4515	4522	4534	4541			
366						.105					8	4505	4514	4523	4533	4542	4550	4556	
367						.167					6	4506	4513	4524	4532	4543			
368						.228					7	4507	4512	4525	4530	4544	4549		
369						.351					7	4508	4511	4526	4539	4545	4548		
370				↓	↓	.522	↓	↓	↓	↓	8	4509	4510	4527	4528	4546	4547	4557	↓

1            7            13            19            25            31            37            43            49            55            61            67            75 76

ALPHA CLM    ICN    ICA    ICBL    ICY    IYN    I    DELTA    T

COEFFICIENTS: \_\_\_\_\_ IDPVAR(1) IDPVAR(2) IDV  
 A = -10° to +10° ONE DATA POINT PER DEGREE  
 α or β \_\_\_\_\_  
 SCHEDULES \_\_\_\_\_

TEST VA 1163 DATA SET COLLATION SHEET

PRETEST  
 POSTTEST

DATA SET IDENTIFIER	CONFIGURATION	SCHD.		PARAMETERS/VALUES								No. of Runs	DELTA Z/LR				
		a	B	PWR	PWR	AX/LR	$\alpha_i$	M <sub>0</sub>	$\delta_{0R}$	$\delta_{0P}$							
RTB 371	NDAC BOOSTER	A	0	0.0	0.0	-.391	0.0	2.0	0.0	0.0	1	4201					
372						-.43						4202					
373						-.019						4203					
374						.043						4204					
375						.105						4205					
376						.167						4206					
377						.228						4207					
378						.351						4208					
379						.501						4209					
380					1000	-.391						4101					
381						-.43						4102					
382						-.019						4103					
383						.043						4104					
384						.105						4105					
385						.167						4106					
386						.228						4107					
387						.351						4108					
388						.501						4109					

1            7            13            19            25            31            37            43            49            55            61            67            7576

ALPHA DCLM    ICN    ICR    ICBL    ICY    CYN    DELTAR

COEFFICIENTS:    A = -10° to +10° ONE DATA POINT PER DEGREE

a or B

SCHEDULES

IDEVAR(1) IDEVAR(2) NDV

TEST VA 1163 DATA SET COLLATION SHEET

PRETEST  
 POSTTEST

DATA SET IDENTIFIER	CONFIGURATION	SCHED.		PARAMETERS/VALUES							No. of Runs	DELTA Z/L <sub>B</sub>						
		α	β	PWR	PWR	AX/L	α	M <sub>0</sub>	β <sub>0</sub>	β <sub>0</sub>		.119						
ATB 389	MDAC BOOSTER	A	0	0.0	0.0	-391	0.0	2.0	20.0	-20.0	1	4801						
390						-143						4802						
391						-019						4803						
392						.043						4804						
393						.105						4805						
394						.167						4806						
395						.228						4807						
396						.351						4808						
397						.522						4809						
398					100.0	-391						4901						
399						-143						4902						
400						-019						4903						
401						.043						4904						
402						.105						4905						
403						.167						4906						
404						.228						4907						
405						.351						4908						
406						.522						4909						

1            7            13            19            25            31            37            43            49            55            61            67            75 76

ALPHA    CLM    ICN    ICA    ICBL    CY    EYH    DELTA    7

COEFFICIENTS:

α or β

SCHEDULES

A = -10° to +10° ONE DATA POINT PER DEGREE

INDVAR(1) INDVAR(2) INDV

TEST VA 1163 DATA SET COLLATION SHEET

PRETEST  
 POSTTEST

DATA SET IDENTIFIER	CONFIGURATION	SCHD.		PARAMETERS/VALUES							No. of Runs	DELTA Z/L <sub>R</sub>									
		α	β	PWR	PWR	ΔX/L <sub>R</sub>	α <sub>i</sub>	M <sub>∞</sub>	δ <sub>α</sub>	δ <sub>β</sub>		.113	.119	.151	.182	.228	.352	.599	.900	1.00	
RTR 407	MDAC B & PETER	A	Q	0.0	0.0	0.0	0.0	0.0	0.0	0.0	9	3101	3201	3218	3219	3236	3237	3252	3253	3253	
408											9	3102	3202	3219	3220	3235	3237	3251	3254		
409											8	3103	3203	3216	3221	3234	3239	3250			
410											7	3104	3204	3215	3222	3233	3240				
411											9	3105	3205	3214	3223	3232	3241	3249	3255		
412											7	3106	3206	3219	3224	3231	3242				
413											8	3107	3207	3212	3225	3230	3243	3248			
414											8	3108	3208	3211	3226	3229	3244	3247			
415											9	3109	3209	3210	3227	3228	3245	3246	3256	✓	
416											8			2401	2418	2419	2436	2437	2447	2447	
417											8			2402	2417	2420	2435	2437	2446		
418											7			2403	2416	2421	2434	2439			
419											6			2404	2415	2422	2433				
420											8			2405	2414	2423	2432	2440	2445		
421											6			2406	2413	2424	2431				
422											7			2407	2412	2425	2430	2441			
423											7			2408	2411	2426	2429	2442			
424											8			2409	2410	2427	2428	2443	2444	✓	

1 7 13 19 25 31 37 43 49 55 61 67 75 76

ALPHA @ C L M I C N I C A I C B L I C Y I C Y N I DELTA @ I

COEFFICIENTS: A = -10° to +10° ONE DATA POINT PER DEGREE

α or β

SCHEDULES

→ IZPVAR(1) IZPVAR(2) NDV



TEST VA 1163 DATA SET COLLATION SHEET

PRETEST  
 POSTTEST

DATA SET IDENTIFIER	CONFIGURATION	SCHD.		PARAMETERS/VALUES						No. of Runs	DELTA Z/ΔP								
		A	B	PWR	PWR	ΔX/ΔP	α	M <sub>0</sub>	δ <sub>02</sub>		δ <sub>02</sub>	.119	.151	.182	.228	.352	.599	.908	10.0
RTB 425	MDAC BOOSTER	A	D	0.0	0.0	.591	10.0	3.0	0.0	0.0	6			2981	2918	2919	2934	2935	2935
426						.143					6			2902	2917	2920	2933	2936	
427						.019					5			2903	2916	2921	2932		
428						.043					4			2904	2915	2922			
429						.105					6			2905	2914	2923	2931	2937	
430						.167					4			2906	2913	2924			
431						.228					5			2907	2912	2925	2930		
432						.351					5			2908	2911	2926	2929		
433						.501	Y				6			2909	2910	2927	2928	2938	Y
434						-.391	-5.0				8	2601	2618	2619	2636	2637	2652	2653	2655
435						.143					8	2602	2617	2620	2635	2638	2651	2651	
436						.019					7	2603	2616	2621	2634	2639	2650		
437						.043					6	2604	2615	2622	2633	2640			
438						.105					8	2605	2614	2623	2632	2641	2649	2655	
439						.167					6	2606	2613	2624	2631	2642			
440						.228					7	2607	2612	2625	2630	2643	2648		
441						.351					7	2608	2611	2626	2629	2644	2647		
442						.502	Y	Y	Y	Y	8	2609	2610	2627	2628	2645	2646	2656	Y

1          7          13          19          25          31          37          43          49          55          61          67          75 76

ALPHA CLM    ICM    ICA    ICBL    IY    IYIN    DELTA PZ    7

COEFFICIENTS:    → |IDPVAR(1)| |IDPVAR(2)| |NDV

α or β    A = -10° to +10° ONE DATA POINT PER DEGREE

SCHEDULES

TEST VA 1163 DATA SET COLLATION SHEET

PRETEST POSTTEST

Table with columns: DATA SET IDENTIFIER, CONFIGURATION, SCHED., PARAMETERS/VALUES, No. of Runs, DELTA Z/ΔR. Rows include data points 444 through 460.

Summary section with fields: ALPHA, CLM, CN, CA, CBL, CY, CYN, DELTA Z, IDPVAR(1), IDPVAR(2), NDV. Includes text: COEFFICIENTS: A = -10° TO +10° ONE DATA POINT PER DEGREE.

TEST VA 1163 DATA SET COLLATION SHEET

PRETEST  
 POSTTEST

DATA SET IDENTIFIER	CONFIGURATION	SCHED.		PARAMETERS/VALUES						No. of Runs	DELTA Z/LP								
		$\alpha$	$\beta$	PWR	PWR	AX/P <sub>0</sub>	$\alpha_2$	M <sub>0</sub>	$\delta_{01}$		$\delta_{02}$	.119	.151	.182	.228	.352	.599	.908	10.0
RT8461	MDAC BOOSTER	A	0	52.0	100.0	.391	10.0	3.0	0.0	0.0	6			2801	2818	2819	2834	2835	2835
462						-.143					6			2802	2817	2820	2837	2836	
463						-.019					5			2803	2816	2821	2832		
464						.043					4			2804	2815	2822			
465						.105					6			2805	2814	2823	2831	2837	
466						.167					4			2806	2813	2824			
467						.228					5			2807	2812	2825	2830		
468						.351					5			2808	2811	2826	2829		
469						.501					6			2809	2810	2827	2828	2838	
470						-.391	5.0				8	2701	2718	2719	2736	2737	2752	2753	2753
471						-.143					8	2702	2717	2720	2735	2738	2751	2754	
472						-.019					7	2703	2716	2721	2734	2739	2750		
473						.043					6	2704	2715	2721	2733	2740			
474						.105					8	2705	2714	2723	2732	2741	2749	2755	
475						.167					6	2706	2713	2724	2731	2742			
476						.228					7	2707	2712	2725	2730	2743	2748		
477						.351					7	2708	2711	2726	2729	2744	2747		
478						.522					8	2709	2710	2727	2728	2745	2746	2756	

1 7 13 19 25 31 37 43 49 55 61 67 75 76

ALPHA CLM ICN ICB ICBL CY CYN DELTA Z

COEFFICIENTS: A = -10° TO +10° ONE DATA POINT PER DEGREE [IDFVAR(1)] [IDFVAR(2)] [NDV]

$\alpha$  or  $\beta$   
 SCHEDULES

TEST VA 1163 DATA SET COLLATION SHEET

8

PRETEST  
 POSTTEST

DATA SET IDENTIFIER	CONFIGURATION	SCHD.		PARAMETERS/VALUES						No. of Runs	DELTA Z/ΔR								
		α	β	PWR	PWR AX/A	α <sub>c</sub>	M <sub>0</sub>	δ <sub>0</sub>	δ <sub>0</sub>		.119	.151	.182	.228	.352	.599	.908	10.0	
RT8 479	INDAC BOOSTER (NG CALMED)	A	0	50.0	100.0	-.391	0.0	3.0	0.0	0.0	4	3201	3218	3219					3223
480						-.143					4	3202	3217	3220					
481						-.019					3	3203	3216						
482						.043					3	3204	3215						
483						.105					4	3205	3214	3221					
484						.167					3	3206	3213						
485						.228					3	3207	3212						
486						.351					3	3208	3211						
487						.522					4	3209	3210	3222					
488	INDAC BOOSTER (PANS=STAN)					-.391					8	5201	5218	5219	5236	5237	5252	5253	5255
489						-.143					8	5202	5217	5220	5235	5238	5251	5254	
490						-.019					7	5203	5216	5221	5234	5239	5250		
491						.043					6	5204		5222	5233	5240			
492						.105					8	5205	5214	5223	5232	5241	5249	5255	
493						.167					6	5206	5213	5224	5231	5242			
494						.228					7	5207	5212	5225	5230	5243	5248		
495						.351					7	5208	5211	5226	5229	5244	5247		
496						.522					8	5209	5210	5227	5228	5245	5246	5256	

1            7            13            19            25            31            37            43            49            55            61            67            7576

ALPHA @ CLM    ICN    ICA    ICB    ICY    ISYN    DELTA    7

COEFFICIENTS: A = -10° TO +10° ONE DATA POINT PER DEGREE → IZPVAR(1) IZPVAR(2) INDV

α or β \_\_\_\_\_

SCHEDULES \_\_\_\_\_

TEST VA 1163 DATA SET COLLATION SHEET

PRETEST  
 POSTTEST

DATA SET IDENTIFIER	CONFIGURATION	SCHD.		PARAMETERS/VALUES						No. of Runs	DELTA Z/l <sub>B</sub>					
		α	β	PWR	PWR	ΔX/l <sub>B</sub>	α <sub>2</sub>	M <sub>00</sub>	δ <sub>00</sub>		δ <sub>00</sub>	113				
RTB497	MDAC ROOSTER	A	D	100.0	0.0	-.391	0.0	3.0	0.0	0.0	1	5001				
498						-.143						5002				
499						-.019						5003				
500						.043						5004				
501						.105						5005				
502						.167						5006				
503						.228						5007				
504						.351						5008				
505				Y	Y	.522						5009				
506				0.0	0.0	-.391						5101				
507						-.143						5102				
508						-.019						5103				
509						.043						5104				
510						.105						5105				
511						.167						5106				
512						.228						5107				
513						.351						5108				
514				Y	Y	.522	Y	Y	Y	Y	Y	5109				

1      7      13      19      25      31      37      43      49      55      61      67      7576  
 ALPHA, Q, CLM, ICM, ICA, ICBL, CY, GYN, DELTA Z, IDPVAR(1), IDPVAR(2), NDV

COEFFICIENTS: A = -10° to +10° ONE DATA POINT PER DEGREE  
 α or β \_\_\_\_\_  
 SCHEDULES \_\_\_\_\_

TEST VA 1163 DATA SET COLLATION SHEET

41

PRETEST  
 POSTTEST

DATA SET IDENTIFIER	CONFIGURATION	SCHD.		PARAMETERS/VALUES								No. of Runs	DELTA Z/RT							
		a	B	PWR	PWR	AX/LA	$\alpha_2$	M <sub>0</sub>	$\delta_{01}$	$\delta_{02}$	.119		.151	.182	.228	.352	.577	.908	10.0	
RTA 575	1112AC REGISTER	A	0	50.0	100.0	-.391	0.0	4.0	0.0	0.0	7	5301	5318	5319	5336	5337	5352	5352		
576						-.143					7	5302	5317	5320	5335	5338	5351			
577						-.019					7	5303	5316	5321	5334	5339	5350			
578						.043					6	5304	5315	5322	5333	5340				
579						.105					7	5305	5314	5323	5332	5341	5349			
580						.167					6	5306	5313	5324	5331	5342				
581						.228					7	5307	5312	5325	5330	5343	5348			
582						.351					7	5308	5311	5326	5329	5344	5347			
583						.522		↓			7	5309	5310	5327	5328	5345	5346	↓		
584						-.391		6.0			6	5401	5418	5419	5436	5437		5437		
585						-.143						5402	5417	5420	5435	5438				
586						-.019						5403	5416	5421	5434	5439				
587						.043						5404	5415	5422	5433	5440				
588						.105						5405	5414	5423	5432	5441				
589						.167						5406	5413	5424	5431	5442				
590						.228						5407	5412	5425	5430	5443				
591						.351						5408	5411	5426	5429	5444				
592						.522	↓	↓	↓	↓	↓	5409	5410	5427	5428	5445		↓		

1 7 13 19 25 31 37 43 49 55 61 67 7576

ALPHA C L M ICN ICA ICB L CY CYN DELTA A 7  
 COEFFICIENTS: \_\_\_\_\_ | IDPVAR(1) | IDPVAR(2) | NDV  
 a or B A = -10° TO +10° ONE DATA POINT PER DEGREE  
 SCHEDULES \_\_\_\_\_

PRETEST  
 POSTTEST

DATA SET IDENTIFIER	CONFIGURATION	SCHED.		PARAMETERS/VALUES							No. of Runs	DELTA Z/2R		
		$\alpha$	$\beta$	PWR	PWR	AX/L	$\alpha$	$M_{02}$	$\delta_{02}$	$\delta_{02}$		.119	.151	10.0
RTB 533	WIND BASTER (110 CANV'D)	A	0	50.0	100.0	-391	0.0	6.0	0.0	0.0	3	5501	5518	5519
534						-143						5502	5517	
535						-019						5503	5516	
536						043						5504	5515	
537						.105						5505	5514	
538						.167						5506	5513	
539						.228						5507	5512	
540						.351						5508	5511	
541						.520						5509	5510	

1            7            13            19            25            31            37            43            49            55            61            67            75 76

ALPHA  $\alpha$  CLM    ICN    ICA    ICRL    CY    CYN    DELTA

COEFFICIENTS: \_\_\_\_\_ DELTA  
 a or  $\beta$  \_\_\_\_\_ IDPVAR(1) IDPVAR(2) NDV  
 SCHEDULES \_\_\_\_\_  
 \_\_\_\_\_

TEST VA 1163 DATA SET COLLATION SHEET

43

PRETEST  
 POSTTEST

DATA SET IDENTIFIER	CONFIGURATION	SCHED.		PARAMETERS/VALUES							No. of Runs	DELTA Z/2R									
		α	β	PWR	PWR	AX/A	α <sub>2</sub>	M <sub>20</sub>	δ <sub>20</sub>	δ <sub>20</sub>		.113	.119	.151	.172	.228	.552	.599	.908	100	
RTR 542	INDAC ORBITER	A	0	0.0	2.0	.391	0.0	2.0	0.0	0.0	9	4201	3301	3318	3319	3336	3337	3352	3353	3358	
543						-.143					9	4202	3302	3317	3320	3325	3338	3351	3354		
544						-.019					8	4203	3303	3316	3321	3334	3339	3350			
545						.043					7	4204	3304	3315	3322	3333	3340				
546						.105					9	4205	3305	3314	3323	3332	3341	3349	3355		
547						.167					7	4206	3306	3313	3324	3331	3342				
548						.228					8	4207	3307	3312	3325	3330	3343	3348			
549						.351					8	4208	3308	3311	3326	3329	3344	3347			
550						.501	Y				9	4209	3309	3310	3327	3328	3345	3346	3356	Y	
551						-.391	5.0				7			3501	3518	3519	3520			3544	
552						-.143					7			3502	3517	3520	3525	3538			
553						-.019					6			3503	3516	3521	3534				
554						.043					5			3504	3515	3522	3533				
555						.105					7			3505	3514	3523	3532				
556						.167					5			3506	3513	3524	3531				
557						.228					6			3507	3512	3525	3530				
558						.351					6			3508	3511	3526	3529				
559						.528	Y	Y	Y	Y	7			3509	3510	3527	3528	3543	3544	Y	

1            7            13            19            25            31            37            43            49            55            61            67            7576

ALPHA C L M    ICN    ICA    ICBL    ICY    ICYN    DELTAR    7

COEFFICIENTS:    \_\_\_\_\_ IDPVAR(1) | IDPVAR(2) | NDV

α or β            A = -10° to +10° ONE DATA POINT PER DEGREE

SCHEDULES        \_\_\_\_\_





TEST VA 1163 DATA SET COLLATION SHEET

45

PRETEST  
 POSTTEST

DATA SET IDENTIFIER	CONFIGURATION	SCHD.		PARAMETERS/VALUES							No. of Runs	DELTA Z/°B							
		A	B	PWR	PWR	AX/°	α	M <sub>0</sub>	δ <sub>0</sub>	δ <sub>0</sub>		.119	.151	.182	.228	.352	.599	.908	1.00
RTB578	MDAC ORBITER	A	D	50.0	100.0	-.391	0.0	2.0	0.0	0.0	7	3401	3418	3419	3436	3439	3452	3456	
579						-.148					8	3402	3417	3420	3435	3438	3451	3454	
580						-.019					7	3403	3416	3421	3434	3437	3450		
581						.043					6	3404	3415	3422	3433	3440			
582						.105					8	3405	3414	3423	3432	3441	3449	3455	
583						.167					6	3406	3413	3424	3431	3442			
584						.228					7	3407	3412	3425	3430	3443	3448		
585						.351					7	3408	3411	3426	3429	3444	3447		
586						.522					8	3409	3410	3427	3428	3445	3446	3496	
587						-.391	5.0				7	3601	3618	3619	3636	3637	3647	3649	
588						-.143					7	3602	3617	3620	3635	3638	3646		
589						-.019					6	3603	3616	3621	3634	3639			
590						.043					5	3604	3615	3622	3633				
591						.105					7	3605	3614	3623	3632	3640	3645		
592						.167					5	3606	3613	3624	3631				
593						.228					6	3607	3612	3625	3630	3641			
594						.351					6	3608	3611	3626	3629	3642			
595						.522					7	3609	3610	3627	3628	3643	3644		

1                    7                    13                    19                    25                    31                    37                    43                    49                    55                    61                    67                    75

ALPHA OCLM    ICN    ICA    ICB    CY    ICYN    DELTA    7

COEFFICIENTS:    A = -10° to 110° ONE DATA POINT PER DEGREE    IDPVAR(1) IDPVAR(2) IND

α or β  
SCHEDULES

PRETEST  
 POSTTEST

DATA SET IDENTIFIER	CONFIGURATION	SCHD.		PARAMETERS/VALUES						No. of Runs	DELTA Z/l <sub>B</sub>								
		α	β	PWR	PWR	ΔX/l <sub>B</sub>	α <sub>i</sub>	M <sub>0</sub>	δ <sub>0α</sub>		δ <sub>0β</sub>	.119	.151	.182	.220	.352	.599	.908	10.0
RT0596	NIDAC WRITER	A	0	50.0	100.0	.391	10.0	2.0	0.0	0.0	6			4001	4018	4019	4034	4035	4038
597						-.143					6			4002	4017	4020	4033	4036	
598						-.019					5			4003	4016	4021	4032		
599						.043					4			4004	4015	4022			
600						.105					6			4005	4014	4023	4031	4037	
601						.167					4			4006	4013	4024			
602						.228					5			4007	4012	4025	4030		
603						.351					5			4008	4011	4026	4029		
604				Y	Y	.501	Y				6			4009	4010	4027	4028	4038	Y
605						0.0	0.0	-.391	0.0		8	3901	3918	3919	3936	3937	3952	3953	3956
606						-.143					8	3902	3917	3920	3935	3938	3951	3954	
607						-.019					7	3903	3916	3921	3934	3939	3950		
608						.043					6	3904	3915	3922	3933	3940			
609						.105					8	3905	3914	3923	3932	3941	3949	3955	
610						.167					6	3906	3913	3924	3931	3942			
611						.228					7	3907	3912	3925	3930	3943	3948		
612						.351					7	3908	3911	3926	3929	3944	3947		
613		Y	Y	Y	Y	.522	Y	Y	Y	Y	8	3909	3910	3927	3928	3945	3946	3956	Y

1            7            13            19            25            31            37            43            49            55            61            67            75 76

ALPHA   C.L.M.   ICH   ICA   ICAL   ISY   ISYN   DELTA   7

COEFFICIENTS:

A = -10° to +10° ONE DATA POINT PER DEGREE

IDPVAR(1) IDPVAR(2) NDV

α or β

SCHEDULES

TEST VA 1163 DATA SET COLLATION SHEET

PRETEST  
 POSTTEST

DATA SET IDENTIFIER	CONFIGURATION	SCND.		PARAMETERS/VALUES						No. of Runs	DELTA Z/ΔP								
		α	β	PWR	PWR	ΔX/ΔY	α <sub>i</sub>	M <sub>0</sub>	δ <sub>0R</sub>		δ <sub>0D</sub>	.119	.151	.182	.228	.352	.599	.908	10.0
RTB 614	NDAC 11.25.17.2	A	0	0.0	1.0	-391	0.0	2.0	20.0	-20.0	8	4401	4414	4415	4429	4430	4441	4442	4445
615						-143					8	4402	4413	4416	4428	4431	4440	4443	
616						-019					6	4403	4412	4417	4437		4439		
617						.105					8	4404	4411	4418	4426	4432	4438	4444	
618						.167					5	4405	4410	4419	4424				
619						.351					7	4406	4407	4420	4423	4433	4436		
620						.522					8	4407	4408	4421	4422	4434	4435	4445	
621						52.0 1000 -391					8	4501	4518	4519	4537	4538	4553	4554	4557
622						-143					8	4502	4517	4520	4536	4539	4552	4555	
623						-019					7	4503	4516	4521	4535	4540	4551		
624						.043					6	4504	4515	4522	4534	4541			
625						.105					8	4505	4514	4523	4533	4542	4550	4556	
626						.167					6	4506	4513	4524	4532	4543			
627						.228					7	4507	4512	4525	4530	4544	4549		
628						.351					7	4508	4511	4526	4529	4545	4548		
629						.522					8	4509	4510	4527	4528	4546	4547	4557	

1      7      13      19      25      31      37      43      49      55      61      67      75.76

ALPHA CLM    ICA    KA    ICBL    CY    CYN    DELTA

COEFFICIENTS: A = -10° to +10° ONE DATA POINT PER DEGREE → IDPVAR(1) IDPVAR(2) NDV

α or β

SCHEDULES

PRETEST  
 POSTTEST

DATA SET IDENTIFIER	CONFIGURATION	SCHD.		PARAMETERS/VALUES							No. of Runs	DELTA Z/LR						
		α	β	PWR	PWR	AX/A	α <sub>i</sub>	M <sub>∞</sub>	δ <sub>∞</sub>	δ <sub>∞</sub>		119						
RTB 630	MDAC ORBITER	A	0	0.0	0.0	-.391	0.0	2.0	0.0	0.0	1	4201						
631						-.143						4202						
632						-.019						4203						
633						.043						4204						
634						.105						4205						
635						.167						4206						
636						.228						4207						
637						.351						4208						
638						.501						4209						
639						100.0						4101						
640						-.143						4102						
641						-.019						4103						
642						.043						4104						
643						.105						4105						
644						.167						4106						
645						.228						4107						
646						.351						4108						
647						.501						4109						

1            7            13            19            25            31            37            43            49            55            61            67            75 76

ALPHA CLM    ICN    ICA    ICBL    ICY    EYN    DELTAR    7

COEFFICIENTS:

A = -10° TO +10° ONE DATA POINT PER DEGREE    IDPVAR(1) IDPVAR(2) NDV

α or β

SCHEDULES

TEST VA 1163 DATA SET COLLATION SHEET

PRETEST  
 POSTTEST

DATA SET IDENTIFIER	CONFIGURATION	SCHD.		PARAMETERS/VALUES							No. of Runs	DELTA Z/ΔB				
		α	β	PWR	PWR	AX/L	α <sub>0</sub>	M <sub>0</sub>	δ <sub>0</sub>	β <sub>0</sub>						
ATA/48	MIDAC EXETER	A	0	0.0	0.0	-391	0.0	2.0	30.0	-20.0	1	.119				
647												4801				
648												4802				
649												4803				
650												4804				
651												4805				
652												4806				
653												4807				
654												4808				
655												4809				
656												4901				
657												4902				
658												4903				
659												4904				
660												4905				
661												4906				
662												4907				
663												4908				
664												4909				
665																

1      7      13      19      25      31      37      43      49      55      61      67      7576

ALPHA CLM    ICN    ICA    ICB    ICY    ICYN    DELTAZ    7

COEFFICIENTS: A = -10° to +10° ONE DATA POINT PER DEGREE → IDPVAR(1) IDPVAR(2) INDV

α OR β \_\_\_\_\_

SCHEDULES \_\_\_\_\_

TEST VA 1165 DATA SET COLLATION SHEET

PRETEST  
 POSTTEST

DATA SET IDENTIFIER	CONFIGURATION	SCHD.		PARAMETERS/VALUES							No. of Runs	DELTA Z/LB									
		a	B	PWR	PWR	AX/LA	α <sub>z</sub>	m <sub>0</sub>	δ <sub>eg</sub>	δ <sub>eo</sub>		.113	.119	.151	.182	.228	.352	.599	.902	1.0.0	
RT8 666	MDAC ORBITER	A	0	0.0	0.0	-391	0.0	3.0	0.0	0.0	9	3101	2201	2218	2219	2236	2237	2252	2253	2255	
667						.143					9	3102	2202	2217	2220	2235	2238	2251	2254		
668						.019					8	3103	2203	2216	2221	2234	2239	2250			
669						.043					7	3104	2204	2215	2222	2233	2240				
670						.105					9	3105	2205	2214	2223	2232	2241	2249	2255		
671						.167					7	3106	2206	2213	2224	2231	2242				
672						.228					8	3107	2207	2212	2225	2230	2243	2248			
673						.351					8	3108	2208	2211	2226	2229	2244	2247			
674						.501	Y				9	3109	2209	2210	2227	2228	2245	2246	2256	Y	
675						-391	5.0				8			2401	2418	2419	2436	2437	2447	2.54	
676						.143					8			2402	2417	2420	2435	2438	2446		
677						.019					7			2403	2416	2421	2434	2439			
678						.043					6			2404	2415	2422	2433				
679						.105					8			2405	2414	2423	2432	2440	2445		
680						.167					6			2406	2413	2424	2431				
681						.228					7			2407	2412	2425	2430	2441			
682						.351					7			2408	2411	2426	2429	2442			
683						.532	Y	Y	Y	Y	8			2409	2410	2427	2428	2443	2444	Y	

1            7            13            19            25            31            37            43            49            55            61            67            75 76

ALPHA CLM    ICN    ICA    ICBL    ICY    ICYN    DELTA Z    7

COEFFICIENTS:

→ [IDPVAR(1)] IDPVAR(2) NDV

α or β

SCHEDULES

\_\_\_\_\_ A = -10° to +10° ONE DATA POINT PER DEGREE \_\_\_\_\_





TEST VA 1163 DATA SET COLLATION SHEET

PRETEST

POSTTEST

DATA SET IDENTIFIER	CONFIGURATION	SCHD.		PARAMETERS/VALUES						No. of Runs	DELTA Z/°B									
		α	β	PWR	PWR	AX/LB	α	M <sub>0</sub>	δ <sub>0</sub>		δ <sub>0</sub>	.113	.119	.151	.182	.221	.352	.599	.908	10.0
RT8 702	IMPAC ORBITER	A	0	50.0	100.0	-.391	0.0	3.0	0.0	0.0	8	3001	2301	2318	2319	2336	2337	2352	2353	2356
703						-.143					7	3002	2302	2317	2320	2335		2351	2354	
704						-.019					7	3003	2303	2316	2321	2334	2339	2350		
705						.043					6	3004	2304	2315	2322	2333	2340			
706						.105					8	3005	2305	2314	2323	2332	2341	2344	2355	
707						.167					6	3006	2306	2313	2324	2331	2342			
708						.228					7	3007	2307	2312	2325	2330	2343	2348		
709						.351					7	3008	2308	2311	2326	2329	2344	2347		
710						.501	Y				8	3009	2309	2310	2327	2328	2345	2346	2356	Y
711						-.391	5.0				7			2501	2518	2519	2536	2537	2547	Y
712						-.143					7			2502	2517	2520	2535	2538	2546	
713						-.019					6			2503	2516	2521	2534	2539		
714						.043					5			2504	2515	2522	2533			
715						.105					7			2505	2514	2523	2532	2540	2545	
716						.167					5			2506	2513	2524	2531			
717						.228					6			2507	2512	2525	2530	2541		
718						.351					6			2508	2511	2526	2529	2542		
719						.522	Y	Y	Y	Y	7			2509	2510	2527	2528	2543	2544	Y

1            7            13            19            25            31            37            43            49            55            61            67            7576

ALPHA, CLM, ICN, ICA, ICB, ICY, ICN, I, I, I, I, DELTA, 7

COEFFICIENTS: A = -10° TO +10° ONE DATA POINT PER DEGREE → IDPVAR(1) | IDPVAR(2) | NDV

α or β \_\_\_\_\_

SCHEDULES \_\_\_\_\_

TEST VA 1163 DATA SET COLLATION SHEET

PRETEST  
 POSTTEST

DATA SET IDENTIFIER	CONFIGURATION	SCHD.		PARAMETERS/VALUES						No. of Runs	DELTA Z/100								
		α	β	PWR	PWR	EX/10	α <sub>2</sub>	M <sub>00</sub>	δ <sub>α</sub>		δ <sub>β</sub>	.119	.151	.182	.228	.352	.599	.908	10.0
RT8720	MDNC ORBITER	A	0	50.0	10.0	3.0	0.0	6.0	6				2801	2818	2819	2824	2835	2838	
721									6				2802	2817	2820	2827	2836		
722									5				2803	2816	2821	2832			
723									4				2804	2815	2822				
724									6				2805	2814	2823	2831	2837		
725									4				2806	2813	2824				
726									5				2807	2812	2825	2830			
727									5				2808	2811	2826	2829			
728									6				2809	2810	2827	2828	2838	Y	
729									8			2701	2718	2719	2736	2737	2752	2753	2756
730									8			2702	2717	2720	2735	2738	2751	2754	
731									7			2703	2716	2721	2734	2759	2750		
732									6			2704	2715	2722	2733	2740			
733									8			2705	2714	2723	2732	2741	2749	2755	
734									6			2706	2713	2724	2731	2742			
735									7			2707	2712	2725	2730	2743	2748		
736									7			2708	2711	2726	2729	2744	2747		
737									8			2709	2710	2727	2728	2745	2746	2756	Y

1      7      13      19      25      31      37      43      49      55      61      67      7576

ALPHA   CLM   ICN   ICA   ICAL   ICY   ICYN   DELTA   2

COEFFICIENTS: \_\_\_\_\_ IDPVAR(1) | IDPVAR(2) | NDV

α or β      A = -10° TO +10° ONE DATA POINT PER DEGREE

SCHEDULES \_\_\_\_\_

PRETEST  
 POSTTEST

DATA SET IDENTIFIER	CONFIGURATION	SCHD.		PARAMETERS/VALUES						No. of Runs	DELTA Z/ΔP								
		α	β	PWR	PWR	ΔX/ΔP	α <sub>z</sub>	M <sub>∞</sub>	δ <sub>01</sub>		δ <sub>02</sub>	.119	.151	.182	.228	.352	.599	.908	10.0
RT8 738	MDAC ORBITER (MOR=5R)	A	0	50.0	100.0	-.391	0.0	3.0	0.0	0.0	f	3201	3218	3219					3223
739						-.143					4	3202	3217	3220					
740						-.019					3	3203	3216						
741						.043					3	3204	3215						
742						.105					4	3205	3214	3221					
743						.167					3	3206	3213						
744						.228					3	3207	3212						
745						.351					3	3208	3211						
746						.522					4	3209	3210	3222					
747	MDAC ORBITER (MOR=5R)					-.391					8	5201	5218	5219	5236	5237	5252	5253	5256
748						-.143					8	5202	5217	5220	5235	5238	5251	5254	
749						-.019					7	5203	5216	5221	5234	5239	5250		
750						.043					6	5204		5222	5233	5240			
751						.105					8	5205	5214	5223	5232	5241	5249	5255	
752						.167					6	5206	5213	5224	5231	5242			
753						.228					7	5207	5212	5225	5230	5243	5248		
754						.351					7	5208	5211	5226	5229	5244	5247		
755						.522					8	5209	5210	5227	5228	5245	5246	5256	

1            7            13            19            25            31            37            43            49            55            61            67            7576

ALPHA QCLM    ICH    ICA    ICBL    CY    SYN    DELTAB    7

COEFFICIENTS:    IDPVAR(1) | IDPVAR(2) | NDV

α or β    A = -10° to +10° ONE DATA POINT PER DEGREE

SCHEDULES

TEST VA 1163 DATA SET COLLATION SHEET

55

PRETEST  
 POSTTEST

DATA SET IDENTIFIER	CONFIGURATION	SCHD.		PARAMETERS/VALUES						No. of Runs	DELTA Z/L <sub>R</sub>								
		α	β	PWR	PWR AX	PWR AY	α <sub>i</sub>	M <sub>α</sub>	δ <sub>α</sub>		δ <sub>β</sub>	1	2	3	4				
RTB 756	ADAC PRINTER	A	0	1000	0.0	-.371	0.0	3.0	0.0	0.0	1	5001							
757						-.443						5002							
758						-.019						5003							
759						.043						5004							
760						.105						5005							
761						.167						5006							
762						.228						5007							
763						.351						5008							
764						.522						5009							
765					0.0	0.0	-.391					5101							
766						-.143						5102							
767						-.019						5103							
768						.043						5104							
769						.105						5105							
770						.167						5106							
771						.228						5107							
772						.351						5108							
773						.522						5109							

1            7            13            19            25            31            37            43            49            55            61            67            7576

ALPHA QCLM    ICN    ICA    ICBL    ICY    ICYN    DELTA

COEFFICIENTS: \_\_\_\_\_ IDPVAR(1) IDPVAR(2) INDV

A = -10° to +10° ONE DATA POINT PER DEGREE

α or β

SCHEDULES

TEST VA 1163 DATA SET COLLATION SHEET

PRETEST  
 POSTTEST

DATA SET IDENTIFIER	CONFIGURATION	SCHED.		PARAMETERS/VALUES						No. of Runs	DELTA Z/L <sub>R</sub>							
		α	β	PWR	PWR	ΔX/Δy	α	M <sub>0</sub>	δ <sub>0A</sub>		δ <sub>0D</sub>	.119	.151	.182	.228	.352	.522	.908
RTA 774	11.1116 ORBITER	A	0	50.0	100.0	-391	0.0	4.0	0.0	0.0	7	5301	5318	5319	5336	5337	5352	5352
775						-143					7	5302	5317	5320	5335	5338	5351	
776						-019					7	5303	5316	5321	5334	5339	5350	
777						.043					6	5304	5315	5322	5333	5340		
778						.105					7	5305	5314	5323	5332	5341	5349	
779						.167					6	5306	5313	5324	5331	5342		
780						.228					7	5307	5312	5325	5330	5343	5348	
781						.351					7	5308	5311	5326	5329	5344	5347	
782						.522					7	5309	5310	5327	5328	5345	5346	
783						-391		6.0			6	5401	5418	5419	5436	5437		5352
784						-143						5402	5417	5420	5435	5438		
785						-019						5403	5416	5421	5434	5439		
786						.043						5404	5415	5422	5433	5440		
787						.105						5405	5414	5423	5432	5441		
788						.167						5406	5413	5424	5431	5442		
789						.228						5407	5412	5425	5430	5443		
790						.351						5408	5411	5426	5429	5444		
791						.522						5409	5410	5427	5428	5445		

1 7 13 19 25 31 37 43 49 55 61 67 75 76

ALPHA DCLM ICH ICA IGR L CY CYN DELTA Z 7

COEFFICIENTS: IDPVAR(1) IDPVAR(2) NDV

α or β A = -10° TO +10° ONE DATA POINT PER DEGREE

SCHEDULES

TEST VA 1163 DATA SET COLLATION SHEET

PRETEST  
 POSTTEST

DATA SET IDENTIFIER	CONFIGURATION	SCHD.		PARAMETERS/VALUES							No. of Runs	DELTA Z/ <sup>1</sup> / <sub>B</sub>		
		α	β	PWR	PWR	AX/A	α <sub>0</sub>	M <sub>∞</sub>	δ <sub>0F</sub>	δ <sub>0P</sub>		.119	.151	10.0
ATB 792	MDAC LETTER NO. 792	A	0	50.0	100.0	-.591	0.0	6.0	0.0	0.0	3	5501	5508	5519
793						-.143						5502	5507	
794						-.019						5503	5506	
795						.043						5504	5505	
796						.105						5505	5504	
797						.167						5506	5503	
798						.228						5507	5502	
799						.351						5508	5501	
800						.522						5509	5510	

1            7            13            19            25            31            37            43            49            55            61            67            7576

ALPHA    CLM    ICN    ICA    ICBL    ICY    ICYN    DELTA

COEFFICIENTS:    \_\_\_\_\_    IDPVAR(1) IDPVAR(2) IDV

α or β                      A = -10° TO +10° ONE DATA POINT PER DEGREE          

SCHEDULES        \_\_\_\_\_

PRETEST  
 POSTTEST

DATA SET IDENTIFIER	CONFIGURATION	SCHD.		PARAMETERS/VALUES							No. of Runs	DELTA Z/R <sub>P</sub>							
		α	β	PWR <sub>α</sub>	PWR <sub>β</sub>	ΔX/R <sub>α</sub>	α <sub>i</sub>	M <sub>α</sub>	δ <sub>α</sub>	δ <sub>β</sub>		.113	.119	.151	.182	.228	.352	.579	.908
RTB 801	MDAC ORBITER	A	0	0.0	0.0	-391	0.0	2.0	0.0	0.0	8	3356	3356	3356	3356	3356	3356	3356	3356
802							5.0		0.0	0.0		3544	3544	3544	3544	3544	3544	3544	3544
803							10.0		0.0	0.0		3838	3838	3838	3838	3838	3838	3838	3838
804							0.0	20.0	-20.0			4445	4445	4445	4445	4445	4445	4445	4445
805				Y	Y		0.0		0.0	0.0		3956	3956	3956	3956	3956	3956	3956	3956
806						50.0	100.0		0.0	0.0		3456	3456	3456	3456	3456	3456	3456	3456
807							5.0		0.0	0.0		3644	3644	3644	3644	3644	3644	3644	3644
808							10.0		0.0	0.0		4038	4038	4038	4038	4038	4038	4038	4038
809				Y	Y		0.0		20.0	-20.0		4557	4557	4557	4557	4557	4557	4557	4557
810						0.0	0.0		-5.0	0.0		3756	3756	3756	3756	3756	3756	3756	3756
811							5.0	3.0				2444	2444	2444	2444	2444	2444	2444	2444
812				Y	Y		10.0					2938	2938	2938	2938	2938	2938	2938	2938
813						50.0	100.0		0.0			2356	2356	2356	2356	2356	2356	2356	2356
814							5.0					2544	2544	2544	2544	2544	2544	2544	2544
815							10.0					2838	2838	2838	2838	2838	2838	2838	2838
816				Y	Y		-5.0					2756	2756	2756	2756	2756	2756	2756	2756
817						0.0	0.0		-5.0			2656	2656	2656	2656	2656	2656	2656	2656
818	MDAC ORBITER (PAMB=5 PICO)	Y	Y			50.0	100.0	Y	0.0	Y	Y	5256	5256	5256	5256	5256	5256	5256	5256

1                    7                    13                    19                    25                    31                    37                    43                    49                    55                    61                    67                    75 76

A L P H A X I C L M    I C H    I C A    I C B L    I C Y    I C Y H    I    I D E L T A Z    7

COEFFICIENTS:    A = -10° to +10° ONE DATA POINT PER DEGREE    I D P V A R ( 1 ) | I D P V A R ( 2 ) | N D V

α or β  
 SCHEDULES

TEST VA 1163 DATA SET COLLATION SHEET

59

PRETEST  
 POSTTEST

DATA SET IDENTIFIER	CONFIGURATION	SCHD.		PARAMETERS/VALUES							No. of Runs	DELTA Z/kR						
		a	B	PWR	PWR	AX/A	A	M <sub>0</sub>	SEP	SEP		.119	.151	.182	.228	.352	.599	.908
ATB 819	MIDAC ORBITER	A	0	0.0	0.0	-391	0.0	5.0	0.0	0.0	7	361	361	361	361	361	361	361
820							5.0					640	640	640	640	640	640	640
821							10.0					1128	1128	1128	1128	1128	1128	1128
822				↓	↓		-5.0					740	740	740	740	740	740	740
823						50.0	100.0	0.0				460	460	460	460	460	460	460
824							5.0					540	540	540	540	540	540	540
825							10.0					1029	1029	1029	1029	1029	1029	1029
826							-5.0					847	847	847	847	847	847	847
827				↓	↓		-10.0					1228	1228	1228	1228	1228	1228	1228
828						100.0	100.0	0.0				1334	1334	1334	1334	1334	1334	1334
829				↓	↓		5.0					1527	1527	1527	1527	1527	1527	1527
830						50.0	50.0	0.0				1834	1834	1834	1834	1834	1834	1834
831				↓	↓		5.0					1627	1627	1627	1627	1627	1627	1627
832						0.0	0.0	0.0	↓	20.0	-20.0	1934	1934	1934	1934	1934	1934	1934
833						50.0	100.0	0.0	4.0	0.0	0.0	5346	5346	5346	5346	5346	5346	5346
834				↓	↓	50.0	100.0	0.0	6.0			5445	5445	5445	5445	5445	5445	5445

1            7            13            19            25            31            37            43            49            55            61            67            7576

ALPHA OCLM    ICN    ICA    ICB    CY    CYN    DELTAZ    7

COEFFICIENTS:    A = -10° TO +10° ONE DATA POINT PER DEGREE    IDPVAR(1) IDPVAR(2) INDV

a or β

SCHEDULES



TEST VA 1163 DATA SET COLLATION SHEET

PRETEST  
 POSTTEST

DATA SET IDENTIFIER	CONFIGURATION	SCHD.		PARAMETERS/VALUES							No. of Runs	DELTA Z/ $\Delta P$							
		$\alpha$	$\beta$	PWR	PWR	$\Delta X/\Delta P$	$\alpha$	$M_{CO}$	$\delta_{OP}$	$\delta_{OP}$		113	119	151	182	220	352	599	908
RT8R35	MDAC BOOSTER	A	0	0.0	0.0	-391	0.0	2.0	0.0	0.0	8	3353	3353	3353	3353	3353	3353	3353	
837							10.0					3835	3835	3835	3835	3835	3835	3835	
838				↓	↓		-5.0					3753	3753	3753	3753	3753	3753	3753	
839				50.0	100.0		0.0					3454	3454	3454	3454	3454	3454	3454	
840				↓	↓		5.0					3647	3647	3647	3647	3647	3647	3647	
841				↓	↓		10.0					4035	4035	4035	4035	4035	4035	4035	
842				0.0	0.0		0.0		↓	↓		3953	3953	3953	3953	3953	3953	3953	
843				↓	↓		0.0		20.0	-20.0		4442	4442	4442	4442	4442	4442	4442	
844				50.0	100.0		0.0	↓	20.0	-20.0		4554	4554	4554	4554	4554	4554	4554	
845				0.0	0.0		0.0	3.0	0.0	0.0		2253	2253	2253	2253	2253	2253	2253	
846							5.0					2447	2447	2447	2447	2447	2447	2447	
847							10.0					2935	2935	2935	2935	2935	2935	2935	
848				↓	↓		-5.0					2653	2653	2653	2653	2653	2653	2653	
849				50.0	100.0		0.0					2353	2353	2353	2353	2353	2353	2353	
850				↓	↓		5.0					2547	2547	2547	2547	2547	2547	2547	
851							10.0					2835	2835	2835	2835	2835	2835	2835	
852							-5.0					2753	2753	2753	2753	2753	2753	2753	
853	MDAC BOOSTER (NO CANON)						0.0					3223	3223	3223	3223	3223	3223	3223	
854	MDAC BOOSTER (PARTIAL)	↓	↓	↓	↓	↓	0.0	↓	↓	↓	↓	5253	5253	5253	5253	5253	5253	5253	

1 7 13 19 25 31 37 43 49 55 61 67 7576

ALPHA, D, CL, M, ICN, ICA, ICB, ICY, ICYN, DELTA Z 7

COEFFICIENTS:  $A = -10^\circ$  TO  $+10^\circ$  ONE DATA POINT PER DEGREE  
 a or b  
 SCHEDULES

TEST VA 1163 DATA SET COLLATION SHEET

G

PRETEST  
 POSTTEST

DATA SET IDENTIFIER	CONFIGURATION	SCHD.		PARAMETERS/VALUES							No. of Runs	DELTA Z/L <sub>B</sub>						
		α	β	PWR	PWR	AX/B	α <sub>i</sub>	M <sub>∞</sub>	δ <sub>0A</sub>	δ <sub>0D</sub>		.119	.151	.182	.228	.352	.599	.908
RTB 855	MDAC BOOSTER	A	0	0.0	0.0	-391	0.0	5.0	0.0	0.0	7	355	355	355	355	355	355	355
856							5.0					637	637	637	637	637	637	637
857							10.0					1131	1131	1131	1131	1131	1131	1131
858							-5.0					737	737	737	737	737	737	737
859				50.0	100.0		0.0					454	454	454	454	454	454	454
860							5.0					537	537	537	537	537	537	537
861							10.0					1032	1032	1032	1032	1032	1032	1032
862							-5.0					850	850	850	850	850	850	850
863							-10.0					1231	1231	1231	1231	1231	1231	1231
864				100.0	100.0		0.0					1334	1334	1334	1334	1334	1334	1334
865							5.0					1527	1527	1527	1527	1527	1527	1527
866				50.0	50.0		0.0					1834	1834	1834	1834	1834	1834	1834
867							5.0					1627	1627	1627	1627	1627	1627	1627
868				0.0	0.0		0.0		20.0	-20.0		1934	1934	1934	1934	1934	1934	1934
869				50.0	100.0			4.0	0.0	0.0		5352	5352	5352	5352	5352	5352	5352
870								6.0				5437	5437	5437	5437	5437	5437	5437
871	MDAC BOOSTER (NO CANARD)							6.0				5519	5519	5519	5519	5519	5519	5519

1      7      13      19      25      31      37      43      49      55      61      67      7576

ALPHA/C/L/M    ICH    ICA    ICBL    IY    IYN    DELTA    ?

COEFFICIENTS:    A = -10° to +10° ONE DATA POINT PER DEGREE    IDPVAR(1) IDPVAR(2) NDV

α or β

SCHEDULES

PRETEST  
 POSTTEST

DATA SET IDENTIFIER	CONFIGURATION	SCHD.		PARAMETERS/VALUES							No. of Runs	MACH NUMBER			
		$\alpha$	B	PWR	PWR	AZ/deg	$\alpha$	$\delta_{\theta}$	$\delta_{\phi}$	AZ/deg		2.0	3.0	5.0	
RTB 572	MDAC LAUNCH (ONE BALANCE)	A	0	100.0	0.0	104	0.0	0.0	0.0	105	3	5701	5701	5601	
873	MDAC LAUNCH (ONE BALANCE)			100.0							3	5702	5702	5602	
874	MDAC LAUNCH (NO CANARD, ONE BALANCE)			100.0							1	5701			
875	MDAC LAUNCH (NO CANARD, ONE BALANCE)			0.0	↓	↓	↓	↓	↓	↓	1	5702			
876	MDAC ORBITER (NO GRIT)			-	0.0	-	-	-	0.0	-	2		102	103	
877	MDAC ORBITER (GRIT ON)			-	0.0	-	-	-	0.0	-	2		101	105	
878	MDAC ORBITER (R=1.0X10 <sup>6</sup> )			-	0.0	-	-	-	0.0	-	1			106	
879	MDAC ORBITER (R=4.0X10 <sup>6</sup> )			-	0.0	-	-	-	0.0	-	1			105	
880	MDAC BOOSTER (NO GRIT)			0.0	-	-	-	0.0	-	-	2		102	103	
881	MDAC BOOSTER (GRIT ON)			0.0	-	-	-	0.0	-	-	2		101	105	
882	MDAC BOOSTER (R=1.0X10 <sup>6</sup> )			0.0	-	-	-	0.0	-	-	1			106	
883	MDAC BOOSTER (R=4.0X10 <sup>6</sup> )			0.0	-	-	-	0.0	-	-	1			105	

1            7            13            19            25            31            37            43            49            55            61            67            7576

GLM    ICN    ICA    ICB    ICY    ICN

COEFFICIENTS: \_\_\_\_\_ IDPVAR(1) IDPVAR(2) NDV

$\alpha$  or  $\beta$  A = -10° to +10° ONE DATA POINT PER DEGREE

SCHEDULES \_\_\_\_\_

## TEST FACILITY DESCRIPTION

Tunnel A is a continuous, closed-circuit, variable density wind tunnel with an automatically driven flexible-plate-type nozzle and a 40- by 40-inch test section. The tunnel can be operated at Mach numbers from 1.5 to 6 at maximum stagnation pressures from 29 to 200 psia, respectively, and stagnation temperatures up to 750°R ( $M_\infty = 6$ ). Minimum operating pressures range from about one-tenth to one-twentieth of the maximum at each Mach number. For a more comprehensive description of Tunnel A, see Reference 3.

TEST CONDITIONS  
TEST V1163

MACH NUMBER	REYNOLDS NUMBER per unit length	DYNAMIC PRESSURE (pounds/sq. inch)	STAGNATION TEMPERATURE (degrees Fahrenheit)
5.01 ± .01	1.09 × 10 <sup>6</sup> ft <sup>-1</sup>	0.73	132 ± 5°

BALANCE UTILIZED: 4.06-Y-36-037 (BOOSTER)

CAPACITY:	CAL:	ACCURACY:	COEFFICIENT TOLERANCE:	
			NEAR MIN. VALUE	NEAR MAX. VALUE, %
NF ± 150 lbs	± 50 lbs	± 0.2 lbs	± .006	1.5
SF ± 150 lbs	± 25 lbs	± 0.1 lbs	± .003	—
AF 25 lbs	25 lbs	± 0.05 lbs	± .002	1.6
PM ± 510 in-lbs	± 125 in-lbs	± 2.4 in-lbs	± .001	1.0
YM ± 510 in-lbs	± 40 in-lbs	± 0.3 in-lbs	± .0005	—
RM ± 100 in-lbs	± 20 in-lbs	± 2.05 in-lbs	± .001	—

COMMENTS: 1. Coefficient tolerances include uncertainties in tunnel conditions and moment transfer distances as well as balance uncertainties.

2. Uncertainty in α and incidence angle = ± 0.1 deg

3. Uncertainty in X/L and Z/L = ± 0.002

TEST CONDITIONS  
 TEST VA 1163

MACH NUMBER	REYNOLDS NUMBER per unit length	DYNAMIC PRESSURE (pounds/sq. inch)	STAGNATION TEMPERATURE (degrees Fahrenheit)
5.01 ± .01	1.09 × 10 <sup>6</sup> , ft <sup>-1</sup>	0.73	132 ± 5°

BALANCE UTILIZED: 4.00-Y-36-050 (ORBITER)

CAPACITY:	CAL:	ACCURACY:	COEFFICIENT TOLERANCE:	NEAR MAX VALUE, %
			NEAR MIN. VALUE	
NF ± 200 lbs	± .75 lbs.	± 0.2 lbs	± .01	2.1
SF ± 200 lbs	± 25 lbs.	± 0.1 lbs	± .006	—
AF 50 lbs	± 25 lbs.	± 0.1 lbs	± .006	7.3
PM ± 680 in-lbs	± 100 in-lbs	± 0.1 in-lbs	± .005	7.3
YM ± 680 in-lbs	± 35 in-lbs	± 0.1 in-lbs	± .007	—
RM ± 100 in-lbs	± 20 in-lbs	± 0.05 in-lbs	± .0005	—

COMMENTS: Same as on previous page.

TEST CONDITIONS  
TEST VA 1163

MACH NUMBER	REYNOLDS NUMBER per unit length	DYNAMIC PRESSURE (pounds/sq. inch)	STAGNATION TEMPERATURE (degrees Fahrenheit)
3.00 ± 0.01	$1.65 \times 10^6, ft^{-1}$	2.02	120
"	$0.96 \times 10^6, ft^{-1}$	1.17	120

BALANCE UTILIZED: 4.06-Y-36-037 (BOOSTER)

CAPACITY:		CAL:	ACCURACY:	COEFFICIENT TOLERANCE: ( $q_\infty = 2.02$ )	
				NEAR MIN. VALUE	NEAR MAX. VALUE, %
NF	± 150 lbs.	± 50	± 0.2	± 0.002	± 1.2
SF	± 150 lbs.	± 25	± 0.1	± 0.001	—
AF	25 lbs	25	± 0.05	± 0.0006	± 1.1
PM	± 510 in-lbs	± 125	± 0.4	± 0.0004	± 1.1
YM	± 510 in-lbs	± 40	± 0.2	± 0.0002	—
RM	± 100 in-lbs	± 20	± 0.05	± 0.0001	—

- COMMENTS: 1. Coefficient tolerances include uncertainties in tunnel conditions and moment transfer distances as well as balance uncertainties.  
 2. Uncertainty in  $\alpha$  and incidence angle = ± 0.1 deg  
 3. Uncertainty in  $x/L$  and  $z/L$  = ± 0.002

TEST CONDITIONS  
TEST VA 1163

MACH NUMBER	REYNOLDS NUMBER per unit length	DYNAMIC PRESSURE (pounds/sq. inch)	STAGNATION TEMPERATURE (degrees Fahrenheit)
3.00 ±.01	1.65 X 10 <sup>6</sup> , ft <sup>-1</sup>	2.02	120
"	0.96 X 10 <sup>6</sup> , ft <sup>-1</sup>	1.17	120

BALANCE UTILIZED: 400-Y-36-050 (ORBITEE)

CAPACITY:	CAL:	ACCURACY:	COEFFICIENT TOLERANCE: ( $q_\infty = 2.02$ )	
			NEAR MIN. VALUE	NEAR MAX. VALUE, %
NF ±200 lbs	±75	±0.2	±0.004	±1.2
SF ±200 lbs	±25	±0.1	±0.002	—
AF 50 lbs	25	±0.1	±0.002	±4.4
PM ±680 in-lbs	±100	±0.1	±0.002	±1.1
YM ±680 in-lbs	±35	±0.1	±0.0007	—
RM ±100 in-lbs	±20	±0.05	±0.0002	—

COMMENTS: \* Same as on previous page.



TEST CONDITIONS  
TEST VA1163

MACH NUMBER	REYNOLDS NUMBER per unit length	DYNAMIC PRESSURE (pounds/sq. inch)	STAGNATION TEMPERATURE (degrees Fahrenheit)
2.00 ± .01	1.77 × 10 <sup>6</sup> , ft <sup>-1</sup>	2.76	120
"	3.28 × 10 <sup>6</sup> , ft <sup>-1</sup>	5.07	120

BALANCE UTILIZED: 400-Y-36-050 (ORBITER)

CAPACITY:	CAL:	ACCURACY:	COEFFICIENT TOLERANCE: (q <sub>∞</sub> = 2.76)	
			NEAR MIN. VALUE	NEAR MAX. VALUE, %
NF ± 200 lbs	± 75	± 0.2	± 0.002	± 0.9
SF ± 200 lbs	± 25	± 0.1	± 0.0015	—
AF 50 lbs	25	± 0.1	± 0.0015	± 0.8
PM ± 180 in-lbs	± 100	± 0.1	± 0.0015	± 2.4
YM ± 680 in-lbs	± 35	± 0.1	± 0.0005	—
RM ± 100 in-lbs	± 20	± 0.05	± 0.0001	—

COMMENTS: Same as on previous page.

TEST CONDITIONS  
 TEST VA 1163

MACH NUMBER	REYNOLDS NUMBER per unit length	DYNAMIC PRESSURE (pounds/sq. inch)	STAGNATION TEMPERATURE (degrees Fahrenheit)
2.00 ± .01	1.77 × 10 <sup>6</sup> ft <sup>-1</sup>	2.76	120
"	3.28 × 10 <sup>6</sup> ft <sup>-1</sup>	5.07	120

BALANCE UTILIZED: 4.06-Y-36-037 (BOOSTER)

CAPACITY:		CAL:	ACCURACY:	COEFFICIENT TOLERANCE: ( $q_{\infty} = 2.76$ )	
				NEAR MIN. VALUE	NEAR MAX. VALUE, %
NF	± 150 lbs.	± 50	± 0.2	± 0.0015	± 0.9
SF	± 150 lbs.	± 25	± 0.1	± 0.0008	—
AF	25 lbs.	25	± 0.05	± 0.0004	± 0.8
PM	± 510 in.-lbs.	± 125	± 0.4	± 0.0003	± 0.8
YM	± 510 in.-lbs.	± 40	± 0.2	± 0.0001	—
RM	± 100 in.-lbs.	± 20	± 0.05	± 0.0001	—

COMMENTS: 1. Coefficient tolerances include uncertainties in tunnel conditions and moment transfer distances as well as balance uncertainties.  
 2. Uncertainty in  $\alpha$  and incidence angle = ± 0.1 deg.  
 3. Uncertainty in  $x/L$  and  $z/L$  = ± 0.002.

## DATA REDUCTION

### FOR SADSAC

In the continuous pitch mode of data acquisition the wind tunnel parameters and model nozzle pressures were recorded at the beginning of each pitch sweep. The outputs of both balances and the angle of attack were scanned continuously at a rate of 67 times each second. Forty scans of these inputs were averaged to compute each data point, and when combined with the pitch rate of approximately 1-degree per second, a data point was computed every 0.6 degree. Linear interpolations were made between data points to obtain the data for even increments of booster angle of attack, and the data were tabulated in 1-degree increments of booster angle of attack from -10 to +10 degrees.

Schlieren photographs were automatically taken at pre-selected angles of attack during each pitch sweep. For these tests a photograph was taken near maximum, zero, and minimum angles of attack. Opening the camera shutter provided a photograph indicator record on the data tape which was used by the computer to calculate the booster angle of attack at which the photograph was taken. The camera shutter speed combined with the model pitching rate yielded an uncertainty in the tabulated photograph angle of attack of approximately  $\pm 0.2$  degree. A report containing a summary of all schlieren photographs will be published by AEDC.

The measured force and moment data for both models were corrected for balance tare and reduced about the respective moment reference points and the body axis system. The dimensional data used to reduce the orbiter measured data to coefficient form are listed and defined below:

$$S_{\text{ref}} = \text{Orbiter wing planform area} = 23.689 \text{ in.}^2 (0.164 \text{ ft}^2)$$

$$l_{\text{ref}} = \text{Orbiter wing mean aerodynamic chord} = 4.193 \text{ in.}$$

$$b = \text{Orbiter wing equivalent span} = 6.5 \text{ in.} (0.542 \text{ ft})$$

The moment reference point (MRP) for the orbiter data is 4.917 inches aft of the nose, on the lateral center line, and 1.390 inches below the top fuselage surface. The dimensional data used to reduce the booster measured data to coefficient form are listed below:

$$S_{\text{ref}} = 44.444 \text{ in.}^2 = \text{model reference area based on a full scale reference area of } 10,000 \text{ ft}^2 \text{ (see Data Report DMS-DR-1054, page 6)}$$

$$l_{\text{ref}} = b = 13.333 \text{ in.} = \text{model reference length based on a full scale reference length and span of } 200 \text{ ft (see Data Report DMS-DR-1054, page 6)}$$

The moment reference point applicable to the booster data is 7.528 inches aft of the model nose, on the booster lateral center line, and 1.194 inches above the bottom fuselage surface.

The  $\Delta X$  and  $\Delta Z$  distances were referenced to the moment reference points of the orbiter and booster and the booster body axis system. For example, the  $\Delta X$  distance is parallel to the longitudinal axis of the booster and between the moment reference points on the orbiter and booster. The  $\Delta Z$  is perpendicular

to the longitudinal axis of the booster and that distance between the moment reference points on the orbiter and booster. Values for  $\Delta X$  and  $\Delta Z$  are positive when the orbiter moment reference point (MRP) is forward and above the booster MRP. Both  $\Delta X$  and  $\Delta Z$  were normalized using the booster fuselage length of 16.184 inches.

The reference lengths used to reduce the orbiter data, booster data and normalize the  $\Delta X$  and  $\Delta Z$  data were different; these different values are listed and discussed above. The large negative values of pitching moment coefficient for the orbiter at a  $-0.391$  value of  $\Delta X/l_B$  and booster power on condition were apparent because the orbiter was in the plume of the booster.

For each dual balance test run the orbiter and booster data were separated and assembled into data sets utilizing  $\Delta Z/l_B$  (SADSAC parameter name DELTAZ) as the first independent variable (IDPVAR(1)) and booster angle of attack as the second independent variable (IDPVAR(2)) (see collation sheets). Test data applicable to a  $\Delta Z/l_B$  value of 10.0 are interference free data.

#### DATA NOMINALIZING

Varying balance and sting deflections which were caused by variations in model attitude and test conditions prevented the data from being obtained at constant values of  $\alpha_I$  and  $\Delta z/l_B$ . The differences between the nominal values and the values obtained during a test run were acceptable at the higher Mach numbers because of low aerodynamic loads. However, the differences

became appreciable at the lower Mach numbers. At the lower Mach numbers (Mach numbers of 2 and 3) pitch-plane coefficients ( $C_N$ ,  $C_{LM}$ , and  $C_A$ ) for the booster and orbiter models were cross-plotted versus  $\alpha_I$  at each booster angle of attack and test condition to adjust the coefficients to nominal  $\alpha_I$  values. These values were then cross-plotted versus  $\Delta z/l_B$  to adjust the coefficients to nominal  $\Delta z/l_B$  values. This nominalizing was accomplished with a digital computer data fairing routine which used third degree polynomials determined by the coordinates and the slope at adjacent data points.

SUMMARY DATA PLOT INDEX

TITLE	DATASETS	PLOTTED COEFFICIENT VARYING	CONDITION VARYING	PAGES
AEDC VA 1163 MDAC Booster and Orbiter Test Data at Mach Number 5	RT8142 THERU RT8282	(A)	Separation Distance	1 - 423

PLOTTED COEFFICIENT SCHEDULE:

(A)  $C_{LM}$ ,  $C_N$ , and  $C_A$  vs.  $\alpha$

FIGURES



Notes:

1. Positive directions of force coefficients, moment coefficients, and angles are indicated by arrows.
2. For clarity, origins of wind and stability axes have been displaced from the center of gravity.

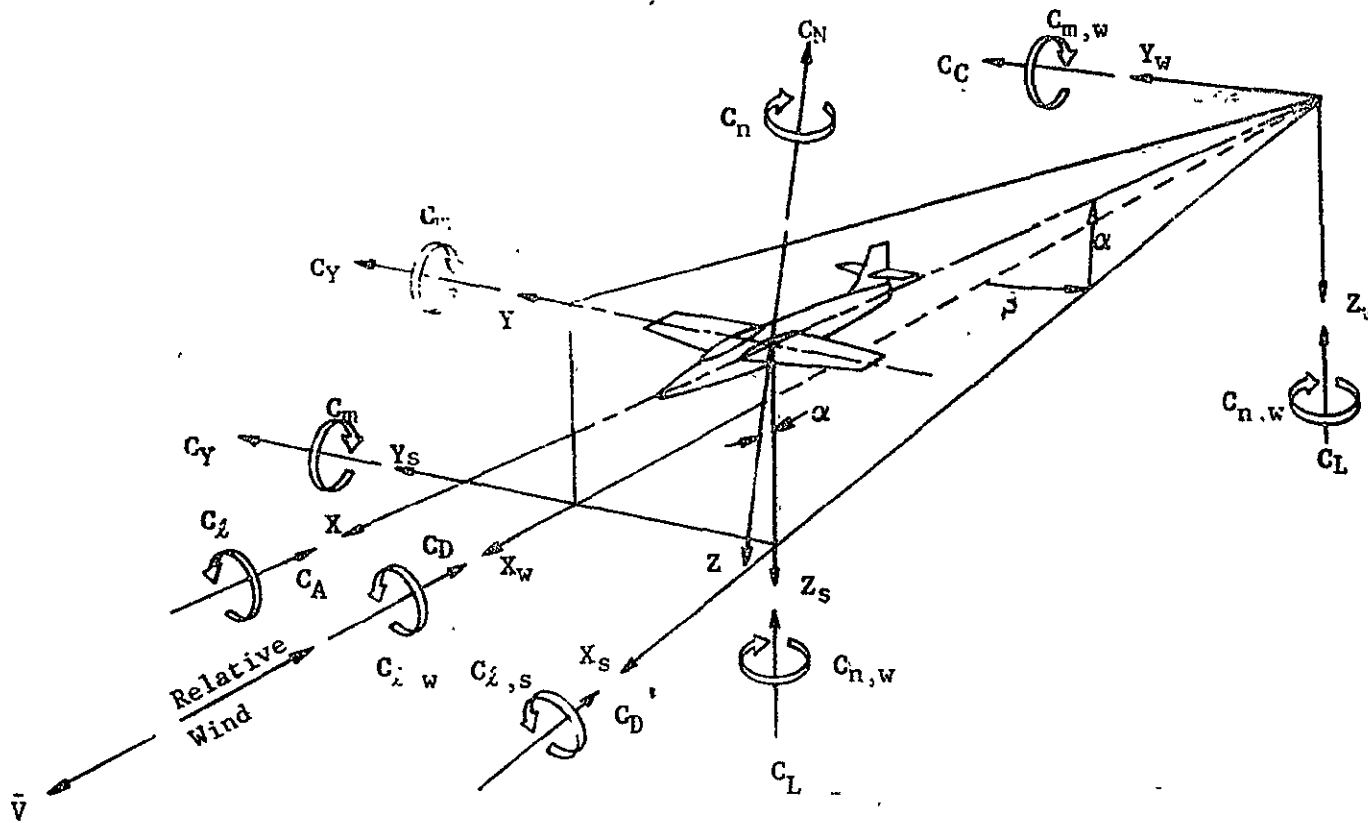

Figure 1. Axis systems, showing direction and sense of force and moment coefficients, angle of attack, and sideslip angle

**40-INCH SUPERSONIC TUNNEL A**

Scale - 1/5

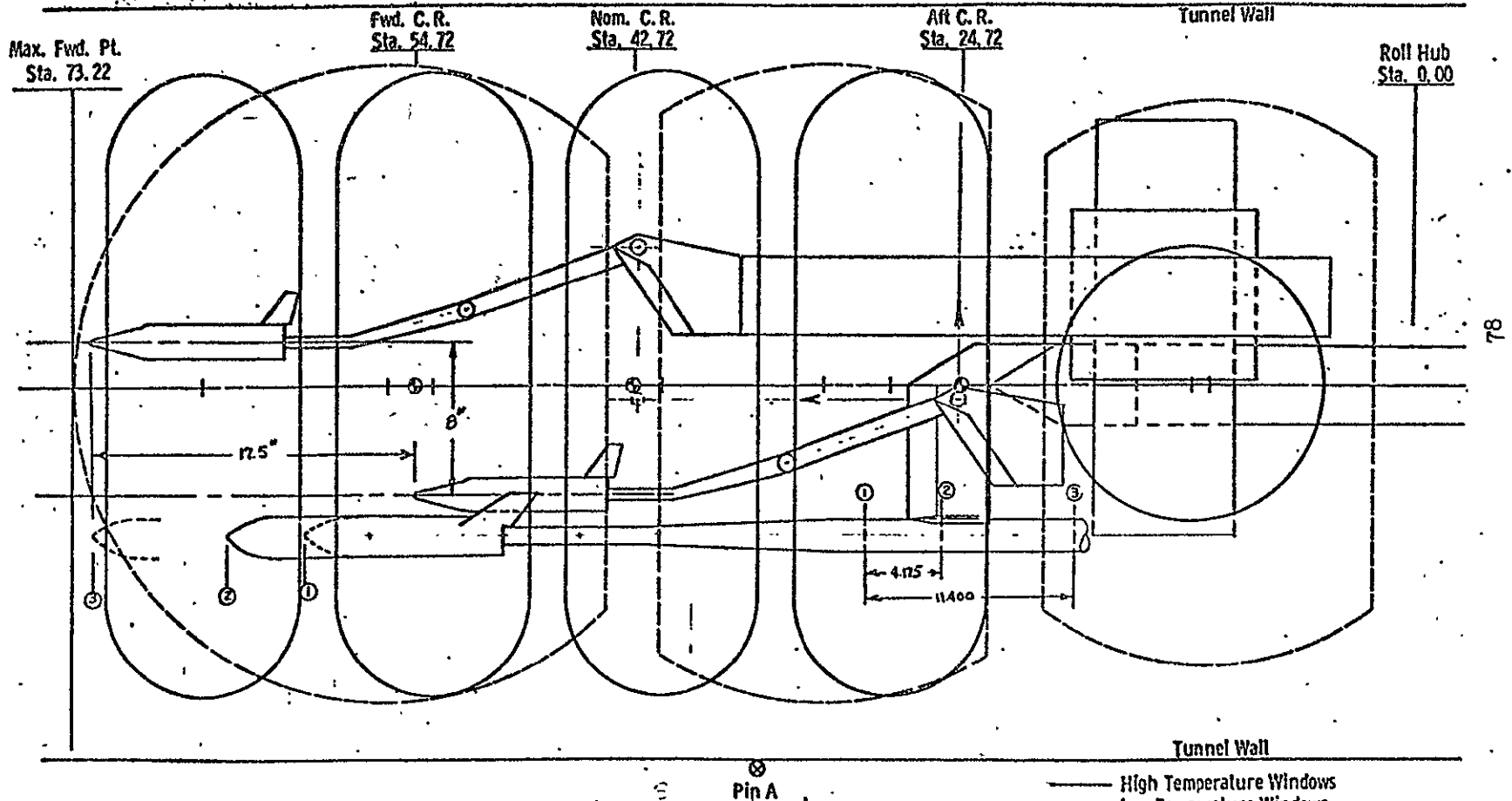

Figure 3 - General arrangement of models in tunnel

78

22

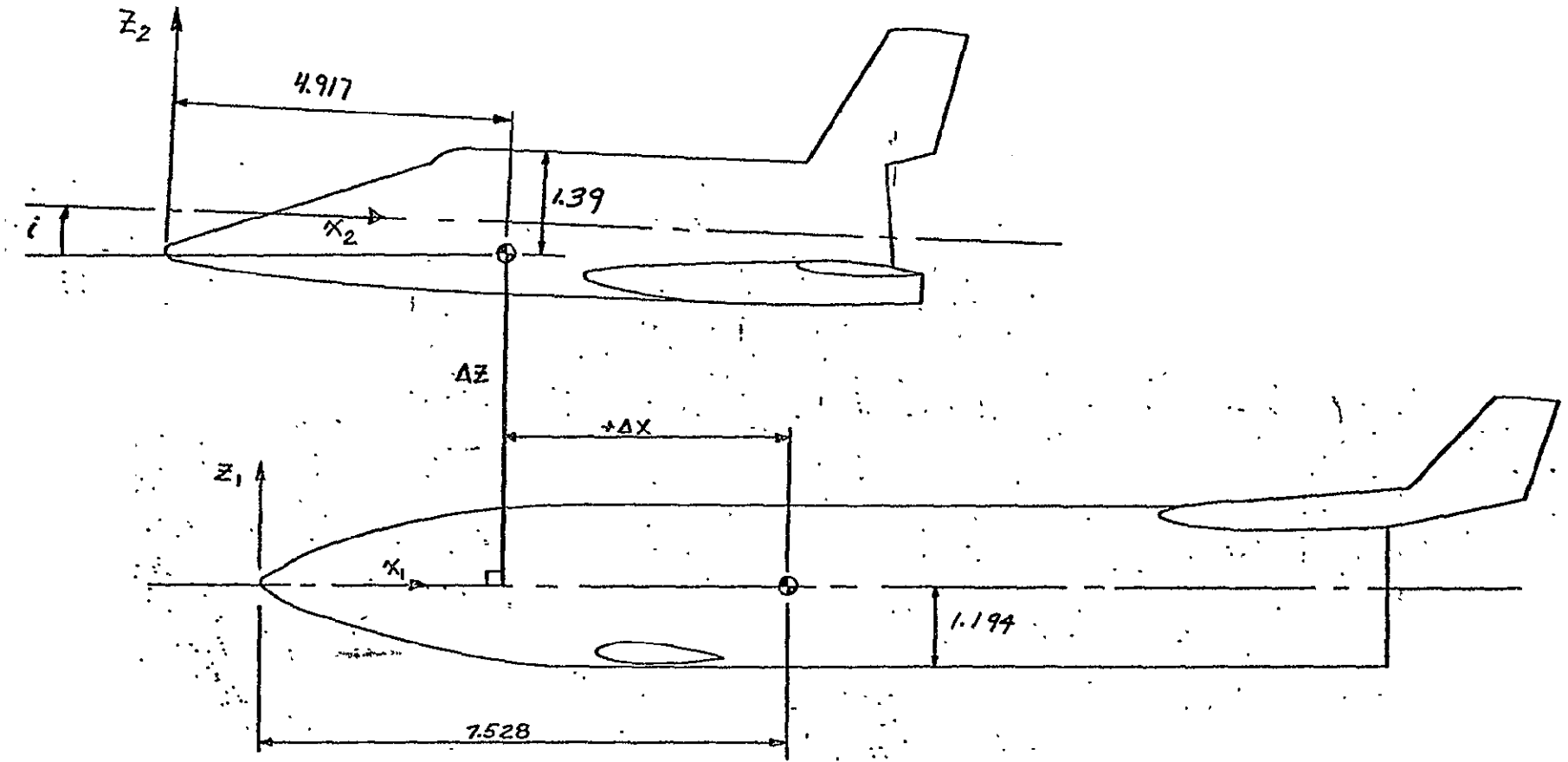

Fig. 2 - Separation Nomenclature and Moment Reference Points

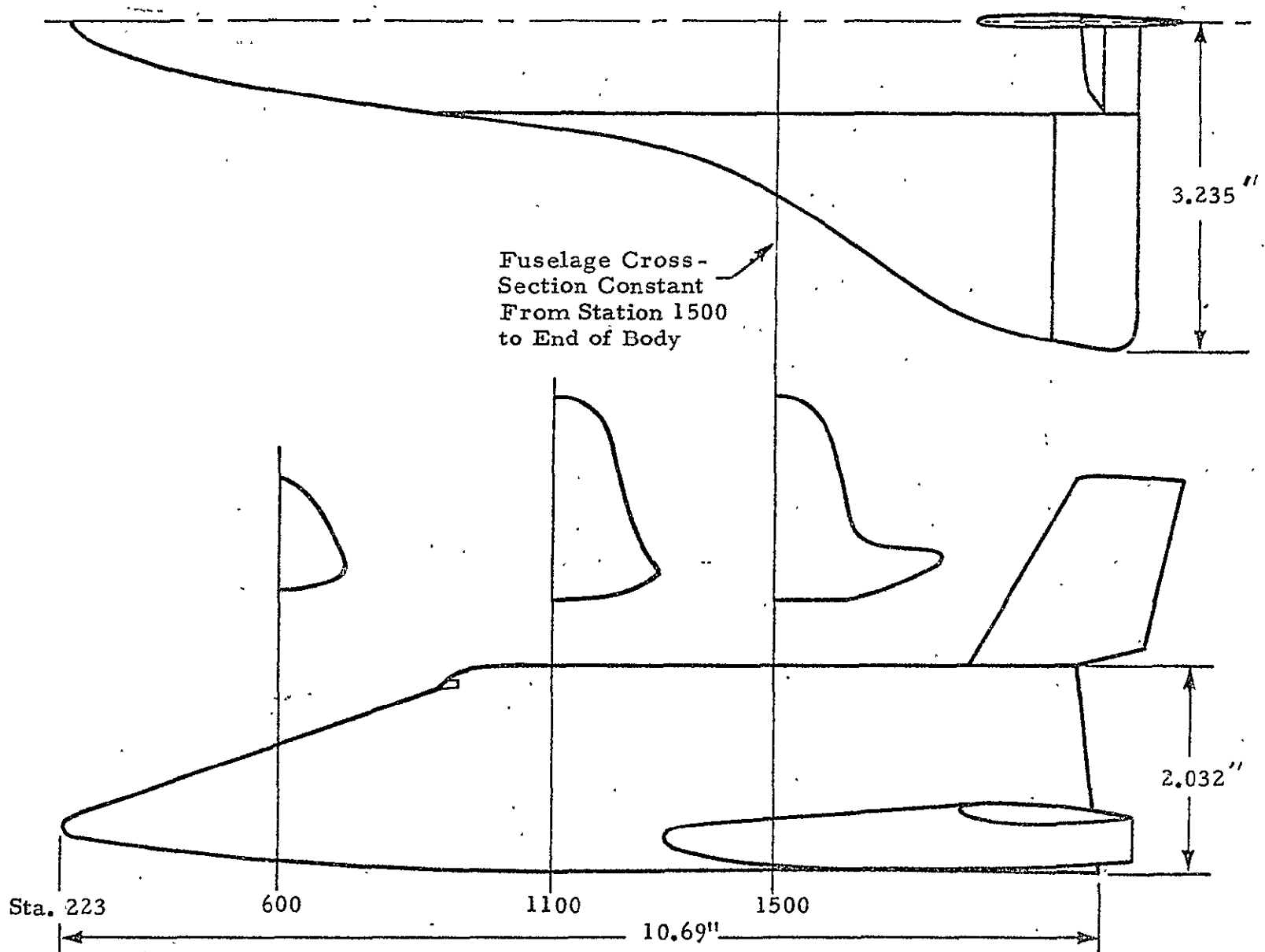

Fig. 4 - Modifications to Orbiter Model

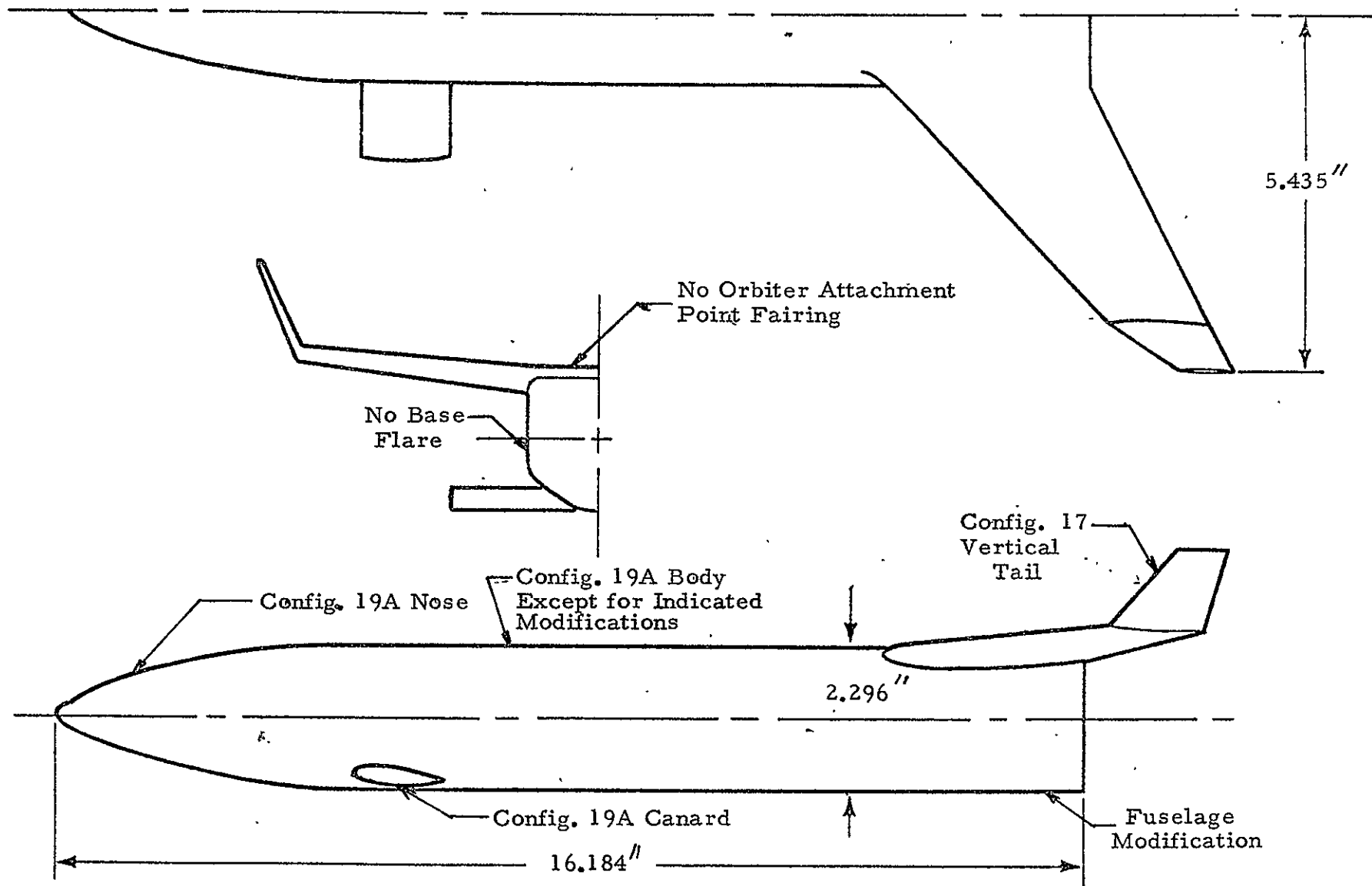
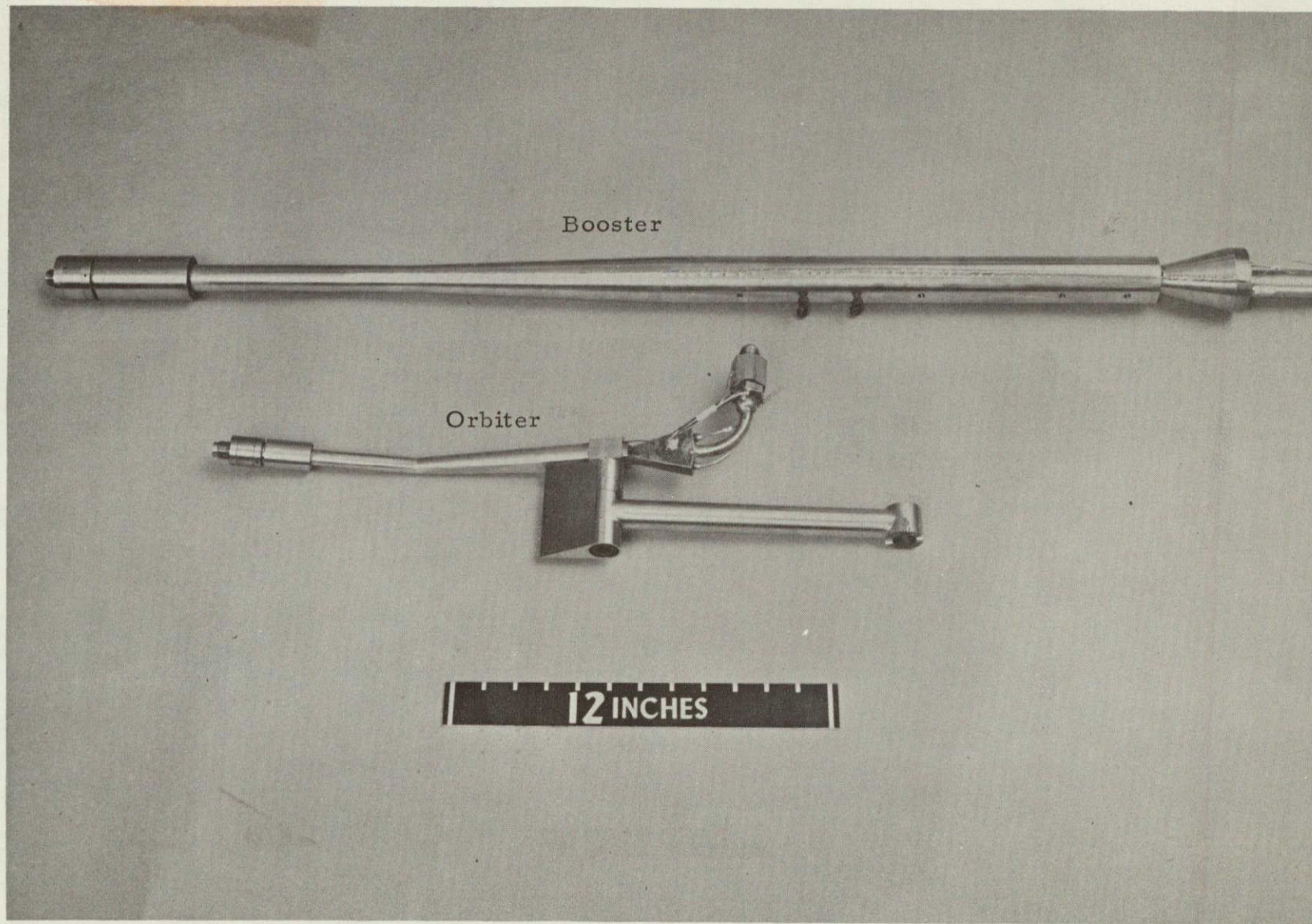

Fig. 5 - Modifications to Booster Model

U.S. AIR FORCE PHOTO-AEDC  
ARG INC. OPERATING CONTRACTOR  
ARNOLD A.F. STATION TENN.

Not cleared for public release without  
prior written approval of the responsible  
Air Force Office of Information.



81

3901

(5-14-71) VA1163 SPACE SHUTTLE NOZZLES

Figure 6. Photograph of Booster and Orbiter Sting Nozzle Hardware

U.S. AIR FORCE PHOTO-AEDC  
ARG INC. OPERATING CONTRACTOR  
ARNOLD A.F. STATION TENN.

Not cleared for public release without  
prior written approval of the responsible  
Air Force Office of Information.

NOT REPRODUCIBLE

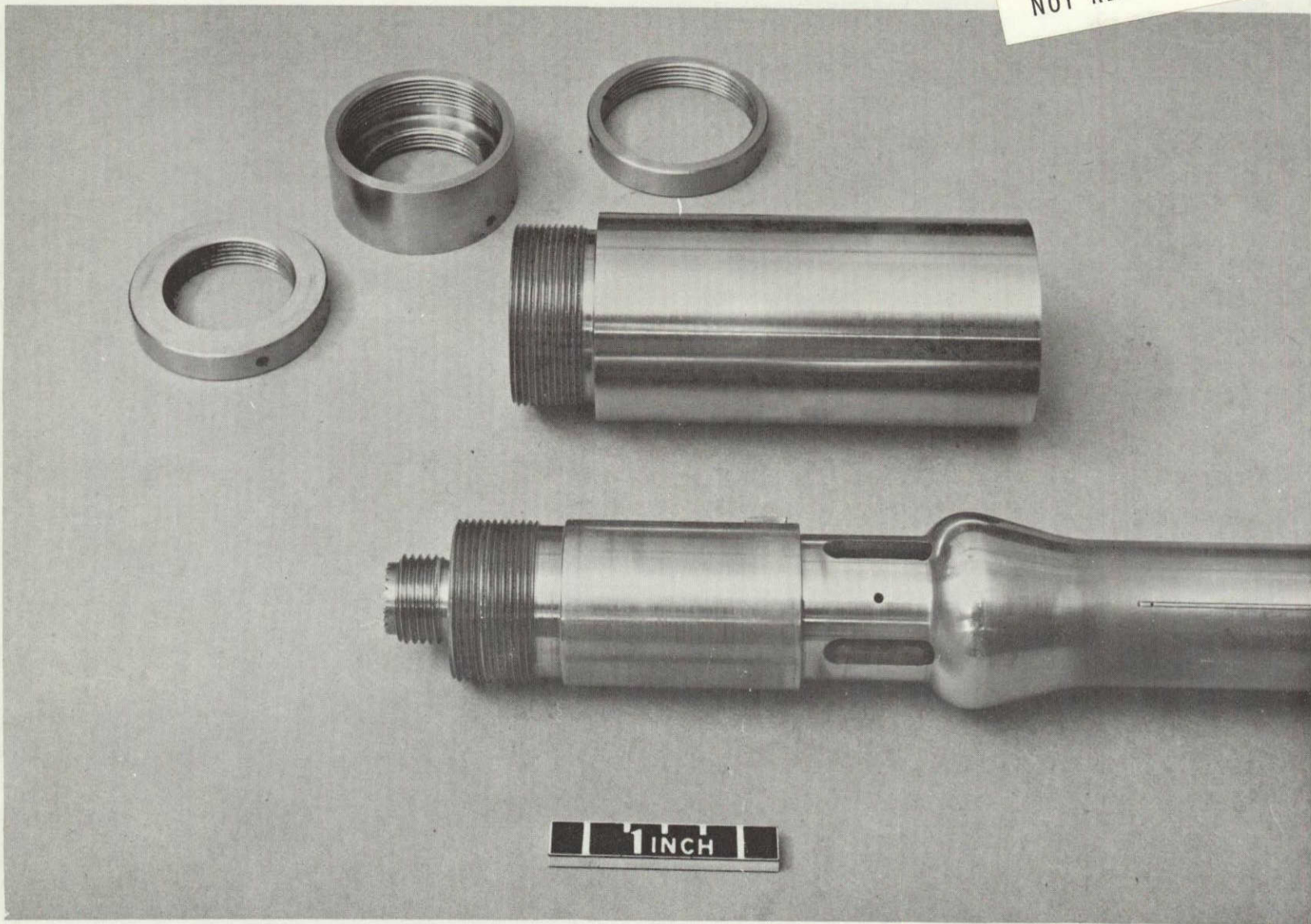

82

3895

(5-14-71) VA1163 SPACE SHUTTLE NOZZLES

Figure 7. Photograph of Booster Nozzle Hardware

U.S. AIR FORCE PHOTO-AEDC  
ARO INC. OPERATING CONTRACTOR  
ARNOLD A.F. STATION TENN.

Not cleared for public release without  
prior written approval of the responsible  
Air Force Office of Information.

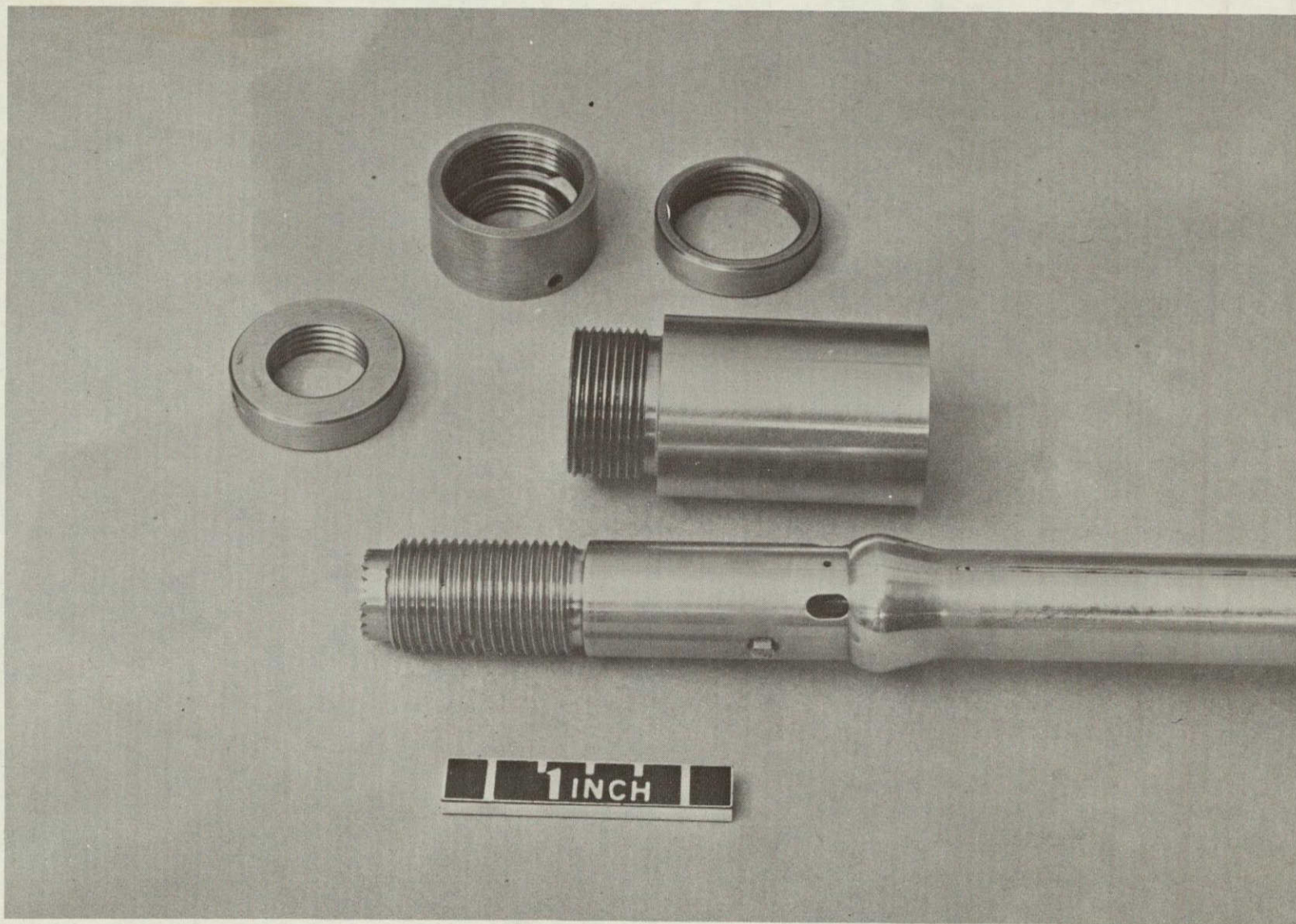

83

3896

(5-14-71) VA1163 SPACE SHUTTLE NOZZLES Figure 8. Photograph of Orbiter Nozzle Hardware



U.S. AIR FORCE PHOTO-AEDC  
ARO INC. OPERATING CONTRACTOR  
ARNOLD A.F. STATION TENN.

Not cleared for public release without  
prior written approval of the responsible  
Air Force Office of Information.

NOT REPRODUCIBLE

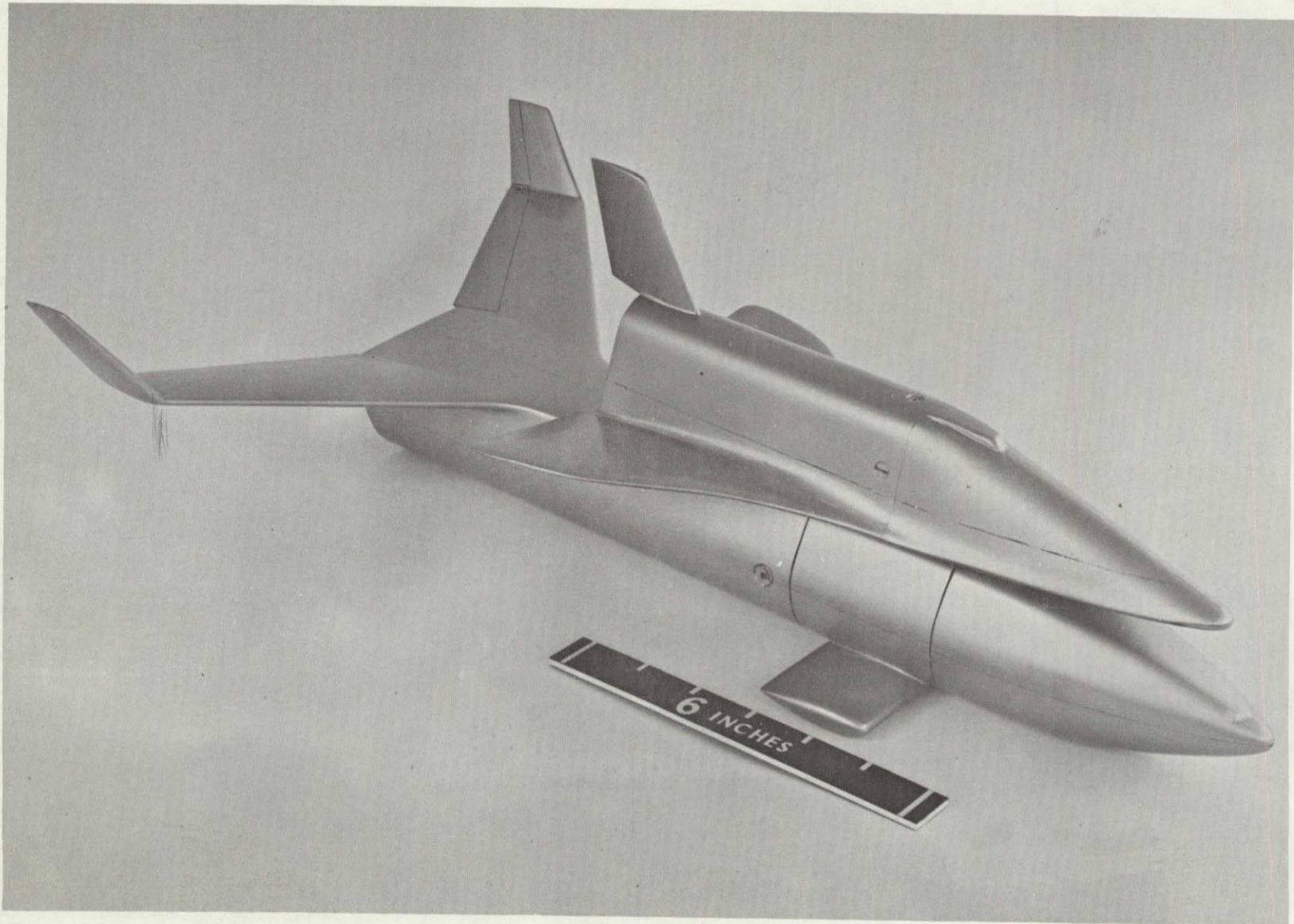

84

Figure 9. Photograph of MDAC Booster and Orbiter Models

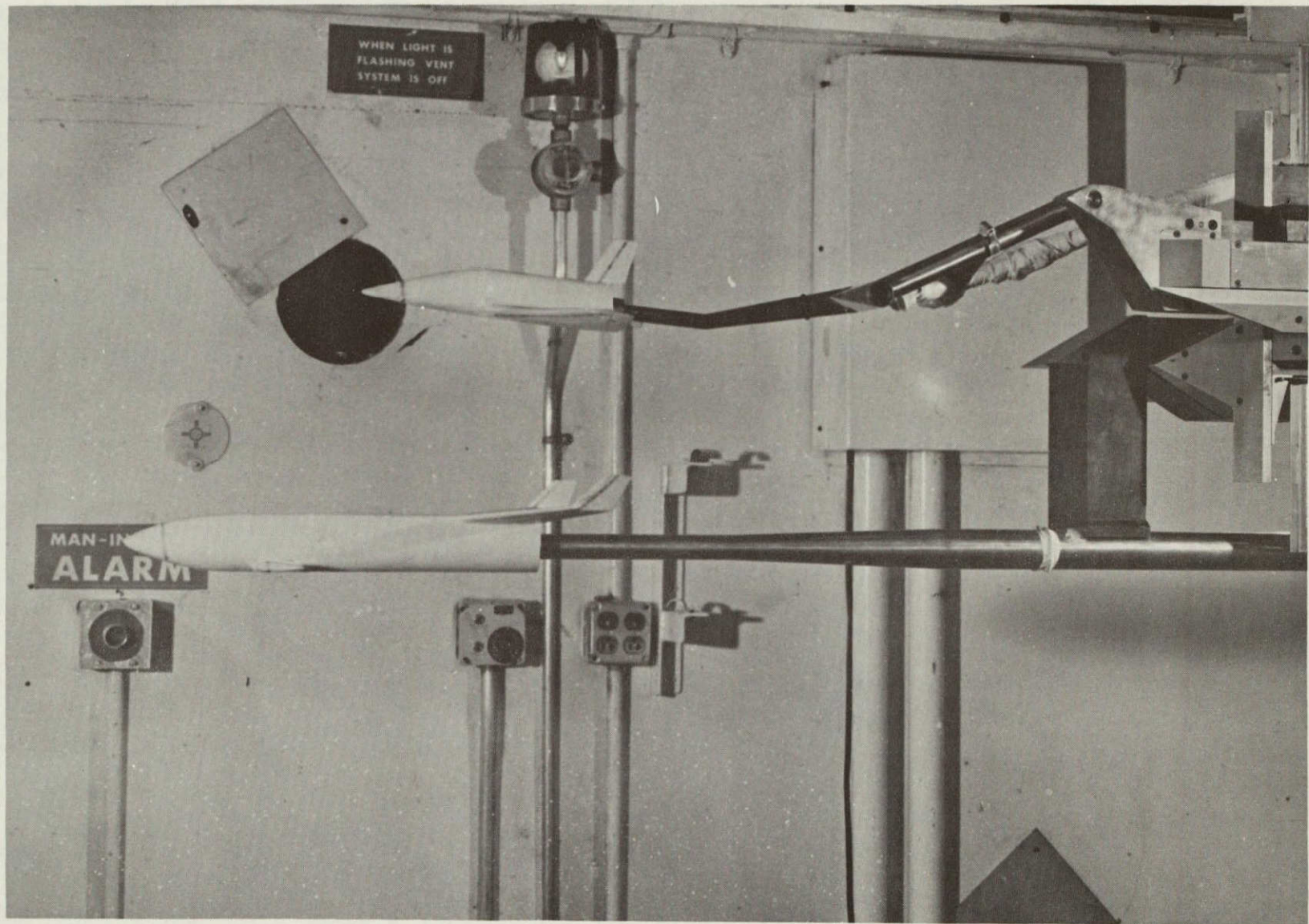

Figure 10. Photograph of Side View of Models and Separation Hardware

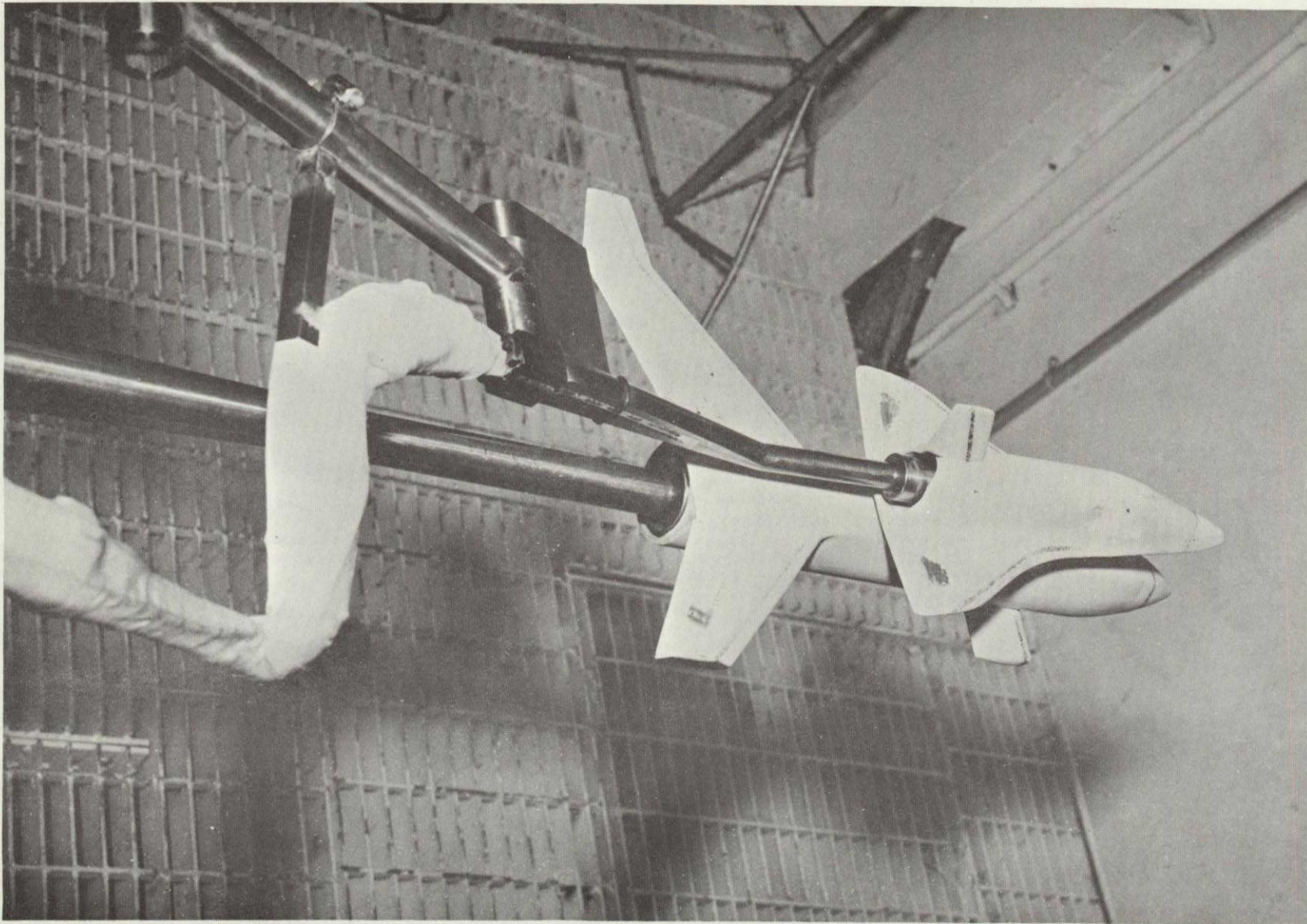

Figure 11. Photograph of Top View of Models and Associated Separation Hardware

MODEL COMPONENT: BODY - MDAC Orbiter

GENERAL DESCRIPTION: Basic fuselage contours including canopy with modified  
aft fuselage cross sections; cross-sectional shape constant from station 1500  
to end of fuselage - model scale 1/180.

DRAWING NUMBER: 255 BJ 00060, Rev. B

<u>DIMENSIONS:</u>	<u>FULL-SCALE</u>	<u>MODEL SCALE</u>
Length	<u>156.4</u>	<u>.869</u>
Max. Width	<u>27.1</u>	<u>.150</u>
Max. Depth	<u>30.3</u>	<u>.168</u>
Fineness Ratio	<u>          </u>	<u>          </u>
Area		
Max. Cross-Sectional	<u>          </u>	<u>          </u>
Planform	<u>          </u>	<u>          </u>
Wetted	<u>          </u>	<u>          </u>
Base	<u>          </u>	<u>          </u>

MODEL COMPONENT: Wing - NDAC Orbiter

GENERAL DESCRIPTION: Model Scale 1/180

DRAWING NUMBER: 255 BJ 00050, Rev. B

DIMENSIONS: FULL-SCALE MODEL SCALE

TOTAL DATA

Area, ft <sup>2</sup>		
Planform	<u>5330.0</u>	<u>.164</u>
Wetted		
Span (equivalent), ft	<u>97.5</u>	<u>.542</u>
Aspect Ratio	<u>1.79</u>	<u>1.79</u>
Rate of Taper		
Taper Ratio	<u>.230</u>	<u>.230</u>
Diehedral Angle, degrees	<u>10.0</u>	<u>10.0</u>
Incidence Angle, degrees	<u>2.0</u>	<u>2.0</u>
Aerodynamic Twist, degrees	<u>0</u>	<u>0</u>
Sweep Back Angles, degrees		
Leading Edge	<u>55.0</u>	<u>55.0</u>
Trailing Edge	<u>0</u>	<u>0</u>
0.25 Element Line	<u>47.0</u>	<u>47.0</u>
Chords:		
Root (Wing Sta. 0.0), INCHES	<u>1084.8</u>	<u>6.027</u>
Tip, (equivalent), INCHES	<u>249.6</u>	<u>1.387</u>
MAC, inches	<u>754.8</u>	<u>4.193</u>
Fus. Sta. of .25 MAC		
W.P. of .25 MAC		
Airfoil Section		
Root (B.L. 162)	<u>0010-64</u>	<u>0010-64</u>
Tip (B.L. 540)	<u>0009-64</u>	<u>0009-64</u>

EXPOSED DATA

Area, ft <sup>2</sup>	<u>3147.3</u>	<u>.097</u>
Span, (equivalent), ft	<u>70.5</u>	<u>.392</u>
Aspect Ratio	<u>1.58</u>	<u>1.58</u>
Taper Ratio		
Chords		
Root, inches	<u>855.0</u>	<u>4.750</u>
Tip, inches	<u>249.6</u>	<u>1.387</u>
MAC	<u>607.2</u>	<u>3.373</u>
Fus. Sta. of .25 MAC		
W.P. of .25 MAC		

MODEL COMPONENT: Elevon - MDAG Orbiter

GENERAL DESCRIPTION: Model Scale 1/180

\_\_\_\_\_  
\_\_\_\_\_  
\_\_\_\_\_

DRAWING NUMBER: 255 BJ 00050, Rev. B

<u>DIMENSIONS:</u>	<u>FULL-SCALE</u>	<u>MODEL SCALE</u>
Area, ft <sup>2</sup>	<u>820.9</u>	<u>.025</u>
Span (equivalent), INCHES	<u>385.2</u>	<u>2.140</u>
Inb'd equivalent chord, INCHES	<u>153.6</u>	<u>.853</u>
Outb'd equivalent chord, INCHES	<u>153.6</u>	<u>.853</u>
Ratio Elevator chord/horizontal tail chord		
At Inb'd equiv. chord	<u>          </u>	<u>          </u>
At Outb'd equiv. chord	<u>          </u>	<u>          </u>
Sweep Back Angles, degrees		
Leading Edge	<u>0</u>	<u>0</u>
Tailing Edge	<u>0</u>	<u>0</u>
Hingeline	<u>0</u>	<u>0</u>
Area Moment (Normal to hinge line)	<u>          </u>	<u>          </u>

MODEL COMPONENT: Vertical Tail - MDAC Orbiter

GENERAL DESCRIPTION: Model Scale 1/180

DRAWING NUMBER: 255 BJ 00050, Rev. B

DIMENSIONS: FULL-SCALE MODEL SCALE

TOTAL DATA

Area, ft <sup>2</sup>		
Planform	<u>580.0</u>	<u>.018</u>
Wetted		
Span (equivalent), ft.	<u>27.5</u>	<u>.153</u>
Aspect Ratio		
Rate of Taper		
Taper Ratio	<u>.638</u>	<u>.638</u>
Dihedral Angle, degrees		
Incidence Angle, degrees		
Aerodynamic Twist, degrees		
Toe-In Angle		
Cant Angle		
Sweep Back Angles, degrees		
Leading Edge	<u>30.0</u>	<u>30.0</u>
Trailing Edge	<u>13.4</u>	<u>13.4</u>
0.25 Element Line	<u>26.2</u>	<u>26.2</u>
Chords:		
Root, inches	<u>309.6</u>	<u>1.720</u>
Tip, (equivalent), inches	<u>196.8</u>	<u>1.093</u>
MAC, inches	<u>21.4</u>	<u>.119</u>
Fus. Sta. of .25 MAC		
W.P. of .25 MAC		
Airfoil Section		
Root	<u>0009-64</u>	<u>0009-64</u>
Tip	<u>0009-64</u>	<u>0009-64</u>

EXPOSED DATA

Area, ft <sup>2</sup>	<u>580.0</u>	<u>.018</u>
Span, (equivalent), ft	<u>27.5</u>	<u>.153</u>
Aspect Ratio		
Taper Ratio	<u>.638</u>	<u>.638</u>
Chords:		
Root, inches	<u>309.6</u>	<u>1.720</u>
Tip, inches	<u>196.8</u>	<u>1.093</u>
MAC, inches	<u>21.4</u>	<u>.119</u>
Fus. Sta. of .25 MAC		
W.P. of .25 MAC		

MODEL COMPONENT: BODY - MDAC Booster

GENERAL DESCRIPTION: Configuration 19A fuselage without base flare and boattail

Model Scale 1/180

DRAWING NUMBER: 256-19-0001, Rev. A

<u>DIMENSIONS:</u>	<u>FULL-SCALE</u>	<u>MODEL SCALE</u>
Length (Ft)	<u>241.7</u>	<u>1.343</u>
Max. Width (Ft)	<u>34.0</u>	<u>.189</u>
Max. Depth (Ft)	<u>34.0</u>	<u>.189</u>
Fineness Ratio	<u>          </u>	<u>          </u>
Area		
Max. Cross-Sectional	<u>          </u>	<u>          </u>
Planform	<u>          </u>	<u>          </u>
Wetted	<u>          </u>	<u>          </u>
Base	<u>          </u>	<u>          </u>



MODEL COMPONENT: Wing - MDAC Booster

GENERAL DESCRIPTION: Configuration 19A Wing

Model Scale 1/180

DRAWING NUMBER: \_\_\_\_\_

DIMENSIONS: \_\_\_\_\_ FULL-SCALE MODEL SCALE

TOTAL DATA

Area, ft <sup>2</sup>		
Planform	6020.0	.136
Wetted		
Span (equivalent), ft.	146.0	.811
Aspect Ratio	3.54	3.54
Rate of Taper		
Taper Ratio	.435	.435
Dihedral Angle, degrees	7.67	7.67
Incidence Angle, degrees	3.0	3.0
Aerodynamic Twist, degrees	0	0
Sweep Back Angles, degrees		
Leading Edge	44.0	44.0
Trailing Edge		
0.25 Element Line		
Chords:		
Root (Wing Sta. 0.0), inches	690.0	3.333
Tip, (equivalent)	300.0	1.667
MAC, inches	520.0	2.889
Fus. Sta. of .25 MAC, inches	3625	20.139
W.P. of .25 MAC, inches		
B.L. of .25 MAC, inches	380	2.111
Airfoil Section		
Root	0010-64	0010-64
Tip	0010-64	0010-64

EXPOSED DATA

Area, ft <sup>2</sup>	4190.0	.129
Span, (equivalent), ft.		
Aspect Ratio		
Taper Ratio		
Chords:		
Root, inches	594.0	3.300
Tip, inches	300.0	1.667
MAC		
Fus. Sta. of .25 MAC		
W.P. of .25 MAC		

MODEL COMPONENT: Vertical Tails - MDAC Booster

GENERAL DESCRIPTION: Configuration 17 Vertical Tails

Model Scale 1/180

DRAWING NUMBER: 256-17-0001, Rev. A

DIMENSIONS: FULL-SCALE MODEL SCALE

TOTAL DATA (Values for one)

Area		
Planform (true)	438	.014
(Side Projection)	397	.012
Span (equivalent), inches	276	1.533
Aspect Ratio	1.21	1.21
Rate of Taper		
Taper Ratio	.520	.520
Toe-In Angle	0	0
Cant Angle	25	25
Sweep Back Angles, degrees		
Leading Edge	40	40
Trailing Edge		
0.25 Element Line		
Chords:		
Root	300	1.667
Tip, (equivalent), inches	156	.867
MAC, inches	236	1.311
Fus. Sta. of .25 MAC		
W.P. of .25 MAC		
Airfoil Section		
Root	NACA 64A-009	NACA 64A-009
Tip	NACA 64A-009	NACA 64A-009

EXPOSED DATA

Area		
Span, (equivalent)		
Aspect Ratio		
Taper Ratio		
Chords		
Root		
Tip		
MAC		
Fus. Sta. of .25 MAC		
W.P. of .25 MAC		

MODEL COMPONENT: Elevon - MDAC Booster

GENERAL DESCRIPTION: Configuration 19A Elevons

Model Scale 1/180

DRAWING NUMBER: 256-19-0001, Rev. A

<u>DIMENSIONS:</u>	<u>FULL-SCALE</u>	<u>MODEL SCALE</u>
Area	<u>617 ft<sup>2</sup></u>	<u>.0191 ft<sup>2</sup></u>
Span (equivalent)	<u>650 in.</u>	<u>3.611 in.</u>
Inb'd equivalent chord	<u>180 in.</u>	<u>.9999 in.</u>
Outb'd equivalent chord	<u>93 in.</u>	<u>.5166 in.</u>
Ratio Elevator chord/horizontal tail chord		
At Inb'd equiv. chord	<u>.32</u>	<u>.3</u>
At Outb'd equiv. chord	<u>.33</u>	<u>.3</u>
Sweep Back Angles, degrees		
Leading Edge	<u>33</u>	<u>33</u>
Tailing Edge	<u>27</u>	<u>27</u>
Hingeline	<u>33</u>	<u>33</u>
Area Moment (Normal to hinge line), Ft <sup>3</sup>	<u>2998</u>	<u>.00004</u>

Are

Are

MODEL COMPONENT: Canard - MDAC Booster

GENERAL DESCRIPTION: Configuration 19A Canard

Model Scale 1/180

DRAWING NUMBER: 256-19-001, Rev. A

DIMENSIONS:

	<u>FULL-SCALE</u>	<u>MODEL SCALE</u>
Theo. Area, Ft <sup>2</sup>	<u>1660</u>	<u>.051</u>
Exp Area, Ft <sup>2</sup>	<u>1215</u>	<u>.033</u>
Aspect Ratio	<u>3.0</u>	<u>3.0</u>
Chord (Incl. Flap), Ft	<u>23.625</u>	<u>.131</u>
Airfoil (360 In. Theo Chord)	NACA <u>63-018</u>	NACA <u>63-018</u>

## NOMENCLATURE

(General)

<u>SYMBOL</u>	<u>SADSAC SYMBOL</u>	<u>DEFINITION</u>
$\alpha$	ALPHA	angle of attack, angle between the projection of the wind $X_w$ -axis on the body X, Z-plane and the body X-axis; degrees
$\beta$	BETA	sideslip angle, angle between the wind $X_w$ -axis and the projection of this axis on the body X-Z-plane; degrees
$\psi$	PSI	yaw angle, angle of rotation about the body Z-axis, positive when the positive X-axis is rotated toward the positive Y-axis; degrees
$\phi$	PHI	roll angle, angle of rotation about the body X-axis, positive when the positive Y-axis is rotated toward the positive Z-axis; degrees
$\rho$		air density; $K_g/m^3$ , slugs/ft <sup>3</sup>
$a$		speed of sound; m/sec, ft/sec
$V$		speed of vehicle relative to surrounding atmosphere; m/sec, ft/sec
$q$	Q(PSI) Q(PSF)	dynamic pressure; $1/2\rho V^2$ , psi, psf
$M$	MACH	Mach number; $V/a$
$RN/L$	RN/L	Reynolds number per unit length; million/ft
$p$		static pressure; psi
$P$		total pressure; psi
$C_p$	CP	pressure coefficient; $(p-p_\infty)/q$
$C_F$		

NOMENCLATURE (Continued)

Reference & C. G. Definitions

<u>SYMBOL</u>	<u>SADSAC SYMBOL</u>	<u>DEFINITION</u>
S		wing area; $m^2$ , $ft^2$
S	SREF	reference area; $m^2$ , $ft^2$
$\bar{c}$		wing mean aerodynamic chord or reference chord; m, ft, in (see $l_{ref}$ or LREF)
$l_{ref}$	LREF	reference length; m, ft, in.; (see $\bar{c}$ )
$b_{ref}$	BREF	wing span or reference span; m, ft, in
$A_b$		base area; $m^2$ , $ft^2$ , $in^2$
c. g.		center of gravity
MRP	MRP	abbreviation for moment reference point
	XMRP	abbreviation for moment reference point on X-axis
	YMRP	abbreviation for moment reference point on Y-axis
	ZMRP	abbreviation for moment reference point on Z-axis

## NOMENCLATURE (Continued)

### Axis System General

<u>SYMBOL</u>	<u>DEFINITION</u>
F	force; F, lbs
M	moment; M, in-lb

<u>Subscript</u>	<u>Definition</u>
N	normal force
A	axial force
L	lift force
D	drag force
Y	force or moment about the Y axis
Z	moment about the Z axis
X	moment about the X axis
s	stability axis system
w	wind axis system
ref	reference conditions
$\infty$	free stream conditions
t	total conditions
b	base

NOMENCLATURE (Continued)  
Body & Stability Axis System

<u>SYMBOL</u>	<u>SADSAC SYMBOL</u>	<u>DEFINITION</u>
<u>Body Axis System</u>		
$C_N$	CN	normal force coefficient; $F_N/qS$
$C_A$	CA	axial force coefficient; $F_A/qS$
$C_{A_b}$	CAB	base axial force coefficient; $[-1] \left[ \frac{(P_b - p_\infty)}{q} \right] (A_b/S)$
$C_{A_f}$	CAF	forebody axial force coefficient; $C_A - C_{A_b}$
$C_n$	CYN	yawing moment coefficient; $M_Z/qS b_{ref}$
$C_l$	CBL	rolling moment coefficient; $M_X/qS b_{ref}$
<u>Common to Both Axis Systems</u>		
$C_m$	CIM	pitching moment coefficient; $M_Y/qS l_{ref}$
$C_y$	CY	side force coefficient; $F_Y/qS$
<u>Stability Axis System</u>		
$C_L$	CL	lift force coefficient; $F_L/qS$
$C_D$	CD	drag force coefficient; $F_D/qS$
$C_{D_b}$	CDB	base drag coefficient
$C_{D_f}$	CDF	forebody drag coefficient; $C_D - C_{D_b}$
$C_n$	CIN	yawing moment coefficient; $M_{Z,s}/qS b_{ref}$
$C_l$	CSL	rolling moment coefficient; $M_{X,s}/qS b_{ref}$
L/D	L/D	lift-to-drag ratio; $C_L/C_D$
L/D <sub>f</sub>	L/DF	lift to forebody drag ratio; $C_L/C_{D_f}$



NOMENCLATURE (Continued)

Surface Definitions

<u>SYMBOL</u>	<u>SADSAC SYMBOL</u>	<u>DEFINITION</u>
$i_t$	HORIZIT	horizontal tail incidence; positive when trailing edge down; degrees
$\delta$		symmetrical surface deflection angle; degrees; positive deflections are:
	AILRON	aileron - total aileron deflection; (left aileron - right aileron)/2
	CANARD	canard - trailing edge down
	ELEVON	elevon - trailing edge down
	ELEVTR	elevator - trailing edge down
	FLAP	flap - trailing edge down
	RUDDER	rudder - trailing edge to the left
	SPOILLR	spoiler - trailing edge down
	TAB	tab - trailing edge down with respect to control surface
$\delta$		antisymmetrical surface deflection angle, degrees; positive trailing edge down:
	AIL-L	left aileron - trailing edge down
	AIL-R	right aileron - trailing edge down
	ELVN-L	left elevon - trailing edge down
	ELVN-R	right elevon - trailing edge down
	SPLR-L	left spoiler - trailing edge down
	SPLR-R	right spoiler - trailing edge down

<u>SURFACE SUBSCRIPTS</u>	<u>DEFINITION</u>
a	aileron
b	base
c	canard
e	elevator or elevon
f	flap
r	rudder or ruddervator
s	spoiler
t	tail

ADDITIONS AND CHANGES TO NOMENCLATURE

<u>SYMBOL</u>	<u>SADSAC SYMBOL</u>	<u>DEFINITION</u>
$i_T$		tail incidence positive when trailing edge down, deg
$V$		velocity of vehicle relative to surrounding atmosphere; m/sec, ft/sec
$\alpha_B$	ALPHAB	booster angle of attack, angle between the projection of the wind $X_w$ -axis on the body X, Z-plane and the body X-axis; deg
$\beta$	BETA	sideslip angle, angle between the wind $X_w$ -axis and the projection of this axis on the body X-Z-plane; deg
$\gamma$		ratio of specific heats
$\Gamma$	DIHDRL	wing dihedral angle; deg
$\rho$		air density; $K_g/m^3$ , slugs/ft <sup>3</sup>
$\alpha_I$	ALPHAI	incidence angle between the orbiter and booster on the XZ plane
$\alpha_O$	ALPHAO	orbiter angle of attack, $\alpha_O = \alpha_B + \alpha_I$
$PWR_B$	BSTPOW	booster power, percent of full thrust
$PWR_O$	ORBPOW	orbiter power, percent of full thrust
$\delta_{eB}$	ELVBST	booster elevon deflection angle, positive is trailing edge down
$\delta_{eO}$	ELVORB	orbiter elevon deflection angle, positive is trailing edge down

ADDITIONS AND CHANGES TO NOMENCLATURE (CONTINUED)

<u>SYMBOL</u>	SADSAC <u>SYMBOL</u>	<u>DEFINITION</u>
$X/l_B$	DELTAX	distance between the MRP on the orbiter and booster measured parallel to the longitudinal axis of the booster, positive when the orbiter MRP is forward of the booster MRP, the distance has been normalized with respect to the booster fuselage length (16.184 inches)
$Z/l_B$	DELTAZ	distance between the MRP on the orbiter and booster measured normal to the longitudinal axis of the booster, positive when the orbiter MRP is above the booster MRP, the distance has been normalized with respect to the booster fuselage length (16.184 inches)

## REFERENCES

1. Sims, Joseph L., "Plume Simulation for Space Shuttle Abort Staging Aerodynamic Testing," Memo S&E-AERO-AF-70-6, December 1970.
2. Baker, L. R., "Calibration of the Propulsion Simulation Nozzles for the Space Shuttle Booster and Orbiter Models for the Abort/Separation Staging Experimental Program," LMSC/HREC D225144, June 1971.
3. "Test Facilities Handbook" (8th Edition), Arnold Engineering Development Center, December 1969.

## TABULATED DATA LISTING

A tabulated data listing, consisting of all aero data sets, both original and those created in arriving at the plotted material to be presented subsequently, is available as an addendum to this report. The tabular listing is made up in two sections:

- (a) a brief summary list of all data sets containing the identifier, the descriptor, and the resident dependent variables.
- (b) a full list of all data sets containing all resident or selected aerodynamic coefficients of the data sets as well as the above mentioned information.

The listing is currently sent on limited distribution to the following organizations:

NASA AMES	Mr. V. Stevens
NASA MSC	Mr. Ray Nelson
AEDC	Mr. L. L. Trimmer
LMSC/HREC	Mr. D. A. Love
NASA LaRC	Mr. J. P. Decker
NASA MSFC	Mr. K. L. Blackwell

If copies of this listing are desired, please contact the above or the cognizant SADSAC personnel who, for this data, is:

J. L. Glynn  
Department 2780  
Chrysler Corporation Space Division  
New Orleans, La. 70129

(504) 255-2304

PLOTTED DATA

# AEDC VA 1163 MDAC BOOSTER AND ORBITER TEST DATA AT MACH NUMBER 5

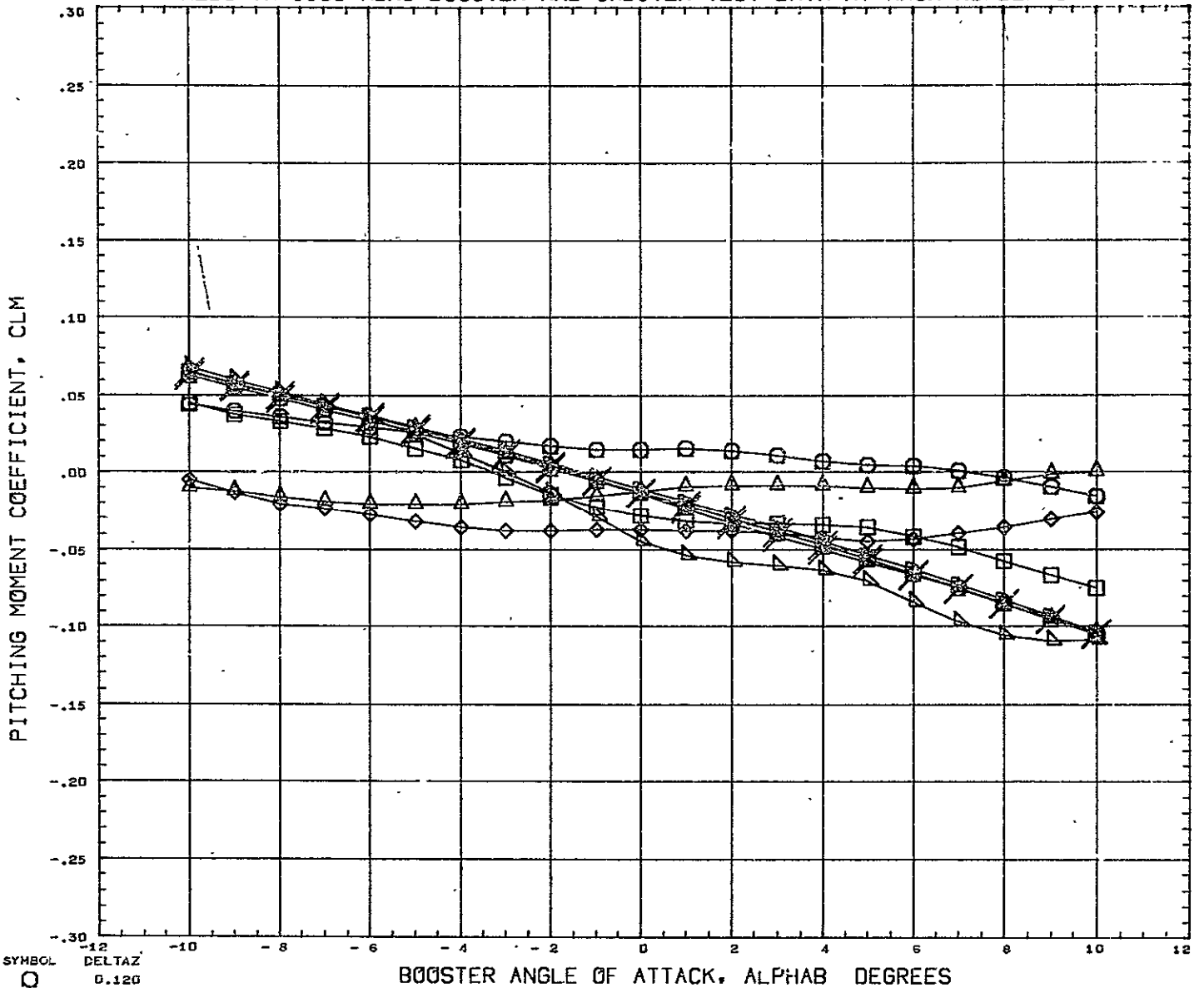

SYMBOL ○ ◇ □ △ × ◇ ○	DELTAZ 0.120 0.151 0.182 0.228 0.352 0.599 0.908 10.000	PARAMETRIC VALUES BSTFOW 0.000 ORBPOW 0.000 .ELTAX - 0.391 ALPHAI 0.000 MACH 5.020 ELVBST 0.000 ELVORB 0.000 BETA 0.000 REFERENCE FILE	REFERENCE INFORMATION REFS 23.6890 SQ IN REFL 4.1930 IN REFD 6.5000 IN XMRP 4.9170 IN YMRP 0.0000 IN ZMRP 1.3900 IN SCALE 0.0055
---	---	---	---

# AEDC VA 1163 MDAC BOOSTER AND ORBITER TEST DATA AT MACH NUMBER 5

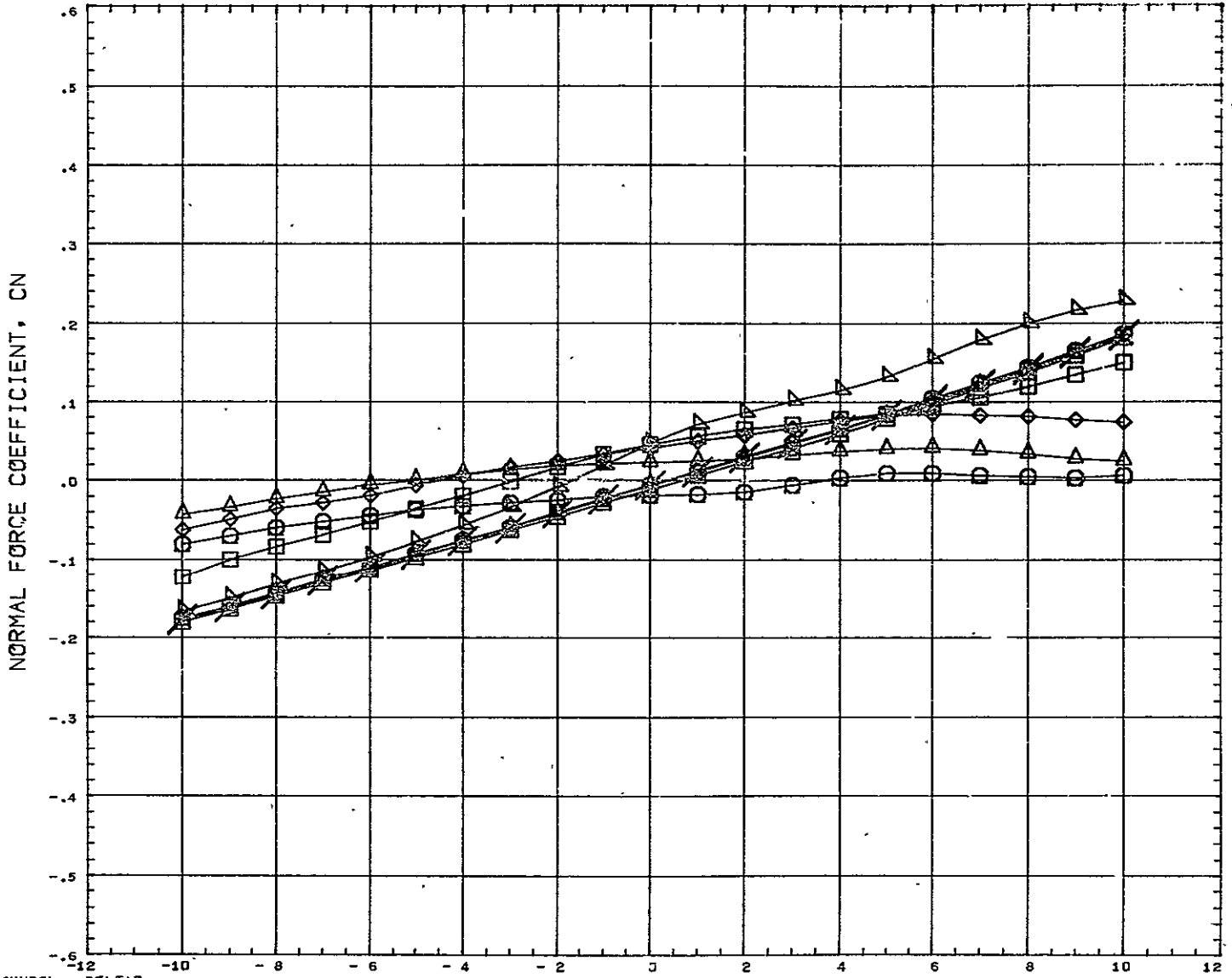

SYMBOL <del>△</del> <del>□</del> <del>◇</del> <del>○</del>	DELTAZ 0.120 0.151 0.182 0.228 0.352 0.599 0.908 10.000	PARAMETRIC VALUES BSTPOW    0.000    ORBPOW    0.000 DELTAX    - 0.391    ALFHAI    0.000 MACH       5.020    ELVBSJ    0.000 ELVORB    0.000    BETA       0.000	REFERENCE INFORMATION REFS       23.6890    SQ IN REFL       4.1930    IN REFB       6.5000    IN XMRP       4.9170    IN YMRP       0.0000    IN ZMRP       1.3900    IN SCALE       0.5055
	BOOSTER ANGLE OF ATTACK, ALPHAB DEGREES		



# AEDC VA 1163 MDAC BOOSTER AND ORBITER TEST DATA AT MACH NUMBER 5

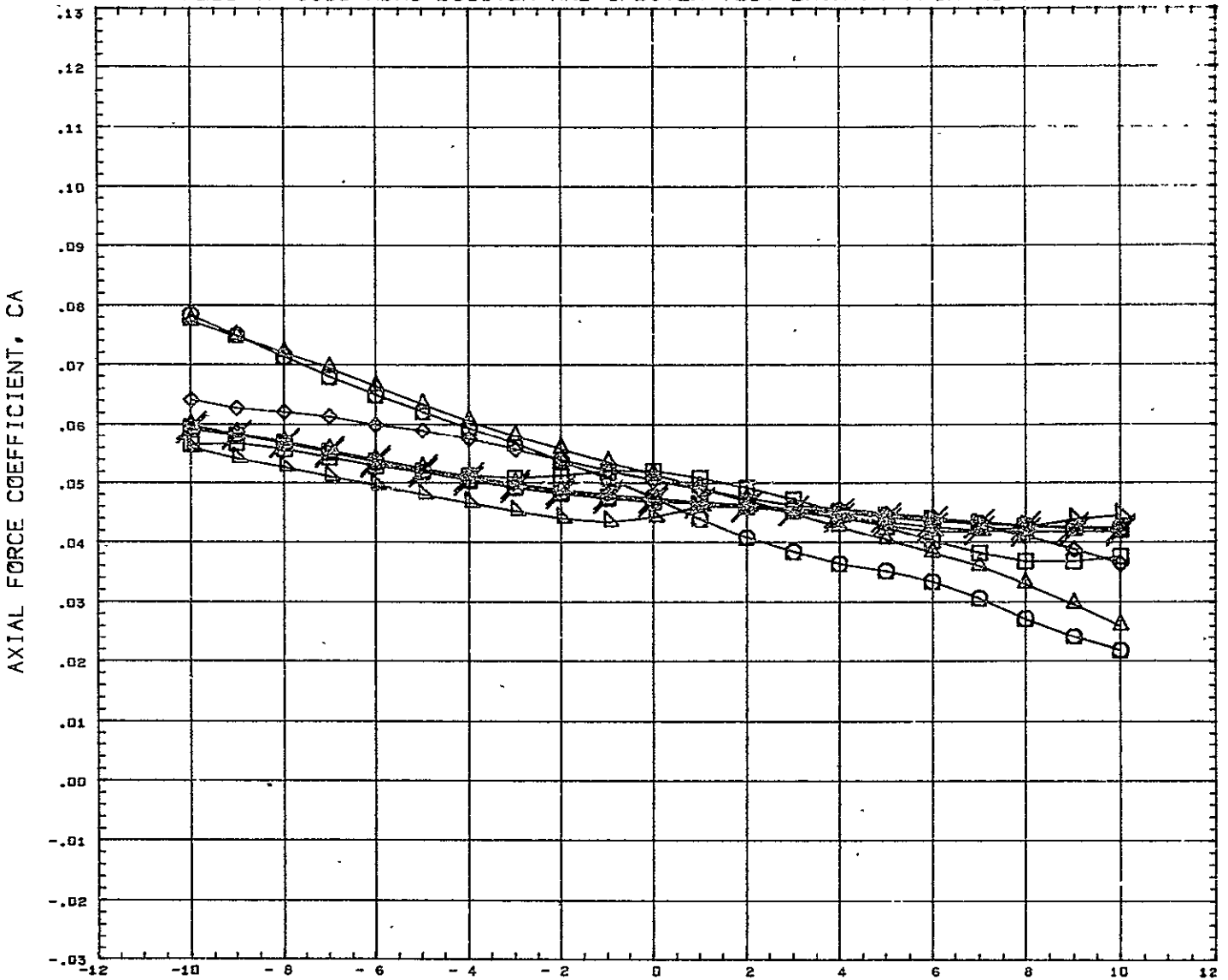

SYMBOL	DELTA Z	PARAMETRIC VALUES				REFERENCE INFORMATION		
○	0.120							
◇	0.151							
□	0.182	BSTPOW	0.000	ORBPOW	0.000	REFS	23.6890	SQ IN
△	0.228	JELTAX	- 0.391	ALPHA1	0.000	REFL	4.1930	IN
×	0.352	MACH	5.020	ELVBST	0.000	REFB	6.5000	IN
○	0.599	ELVORB	0.000	BETA	0.000	XMRP	4.9170	IN
○	0.908					YMRP	0.0000	IN
○	10.000	REFERENCE FILE				ZMRP	1.3900	IN
						SCALE	0.0055	

# AEDC VA 1163 MDAC BOOSTER AND ORBITER TEST DATA AT MACH NUMBER 5

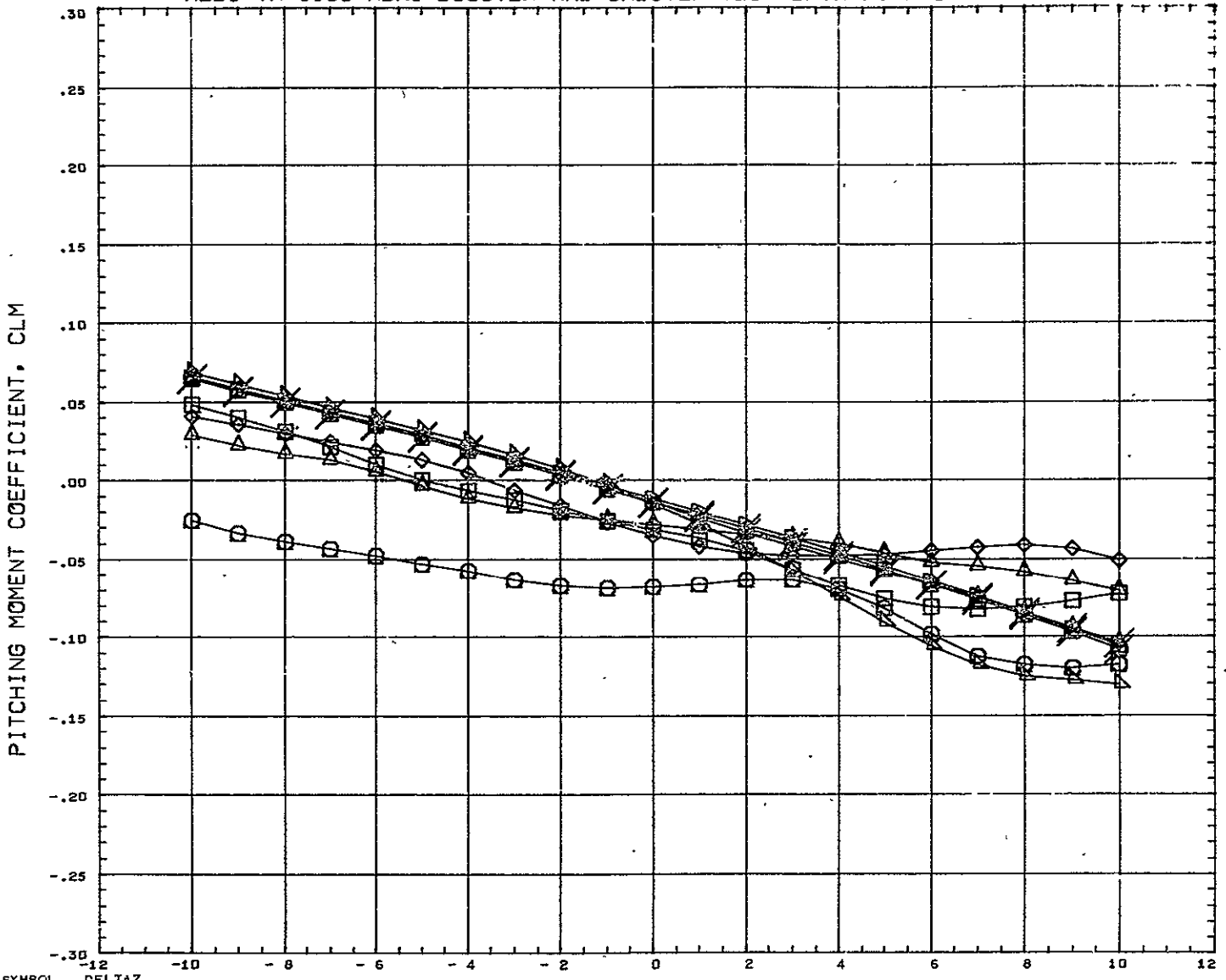

SYMBOL	DELTA Z	PARAMETRIC VALUES				REFERENCE INFORMATION		
○	0.120							
◇	0.151							
□	0.182	BSTPOW	0.000	ORBPOW	0.000	REFS	23.6890	SQ IN
△	0.228	DELTA X	0.143	ALPHA I	0.000	REFL	4.1930	IN
×	0.352	MACH	5.020	ELVBST	0.000	REFB	6.5000	IN
◇	0.599	ELVORB	0.000	BETA	0.000	XNRF	4.9170	IN
○	0.908					YMRF	0.0000	IN
○	10.000	REFERENCE FILE				ZMRF	1.3900	IN
						SCALE	0.0055	

# AEDC VA 1163 MDAC BOOSTER AND ORBITER TEST DATA AT MACH NUMBER 5

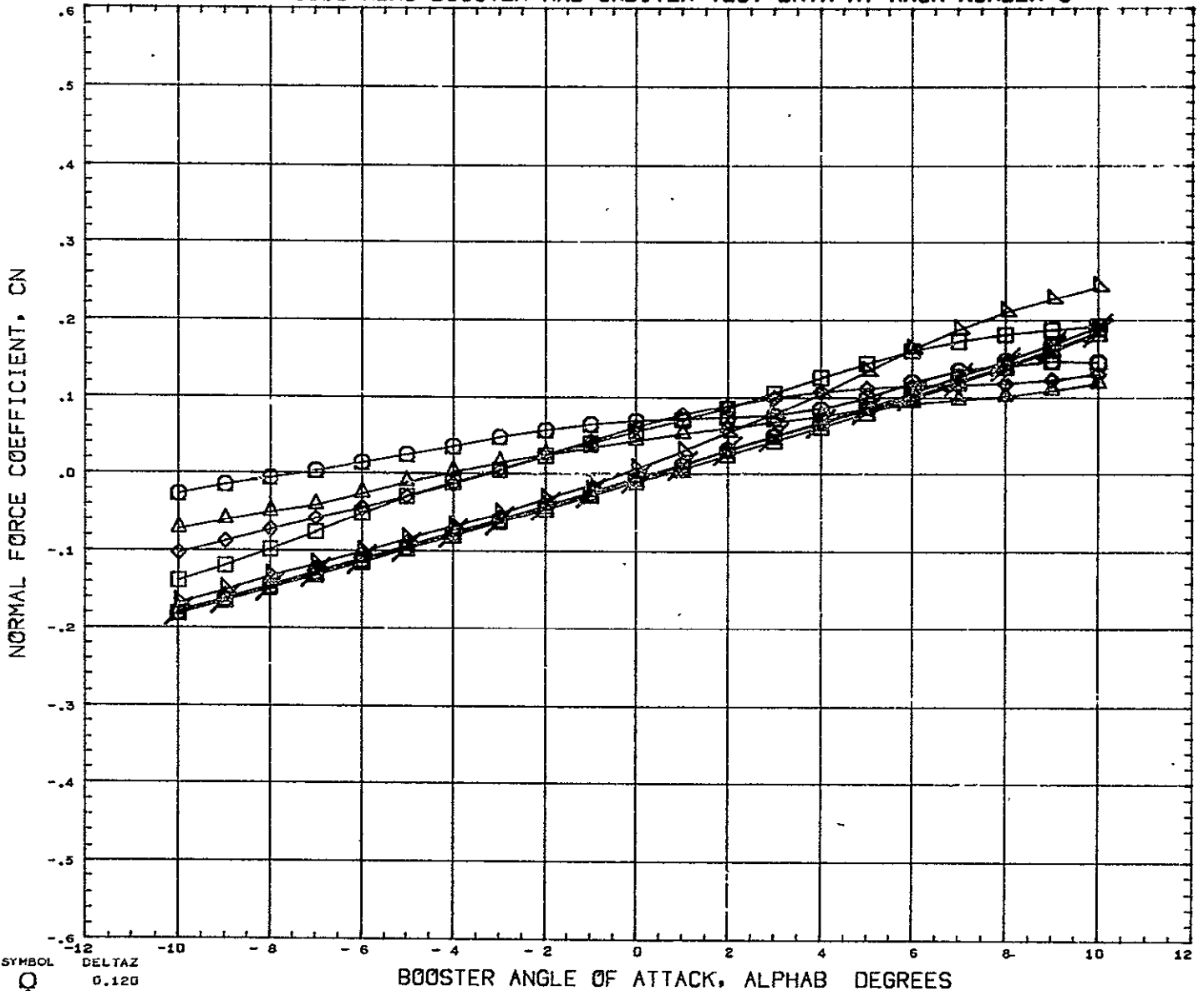

SYMBOL ○ ◊ □ △ ◇ ◊ ○	DELTA Z 0.120 0.151 0.182 0.228 0.352 0.599 0.908 1.0.000	PARAMETRIC VALUES BSTPOW 0.000 ORBPOW 0.000 DELTAX - 0.143 ALPHAI 0.000 MACH 5.020 ELVBST 0.000 ELVORB 0.000 BETA 0.000	REFERENCE INFORMATION REFS 23.6890 SQ IN REFL 4.1930 IN REFB 6.5000 IN XMRF 4.9170 IN YMRF 0.0000 IN ZMRF 1.3900 IN SCALE 0.0055
1.0.000 REFERENCE FILE			

# AEDC VA 1163 MDAC BOOSTER AND ORBITER TEST DATA AT MACH NUMBER 5

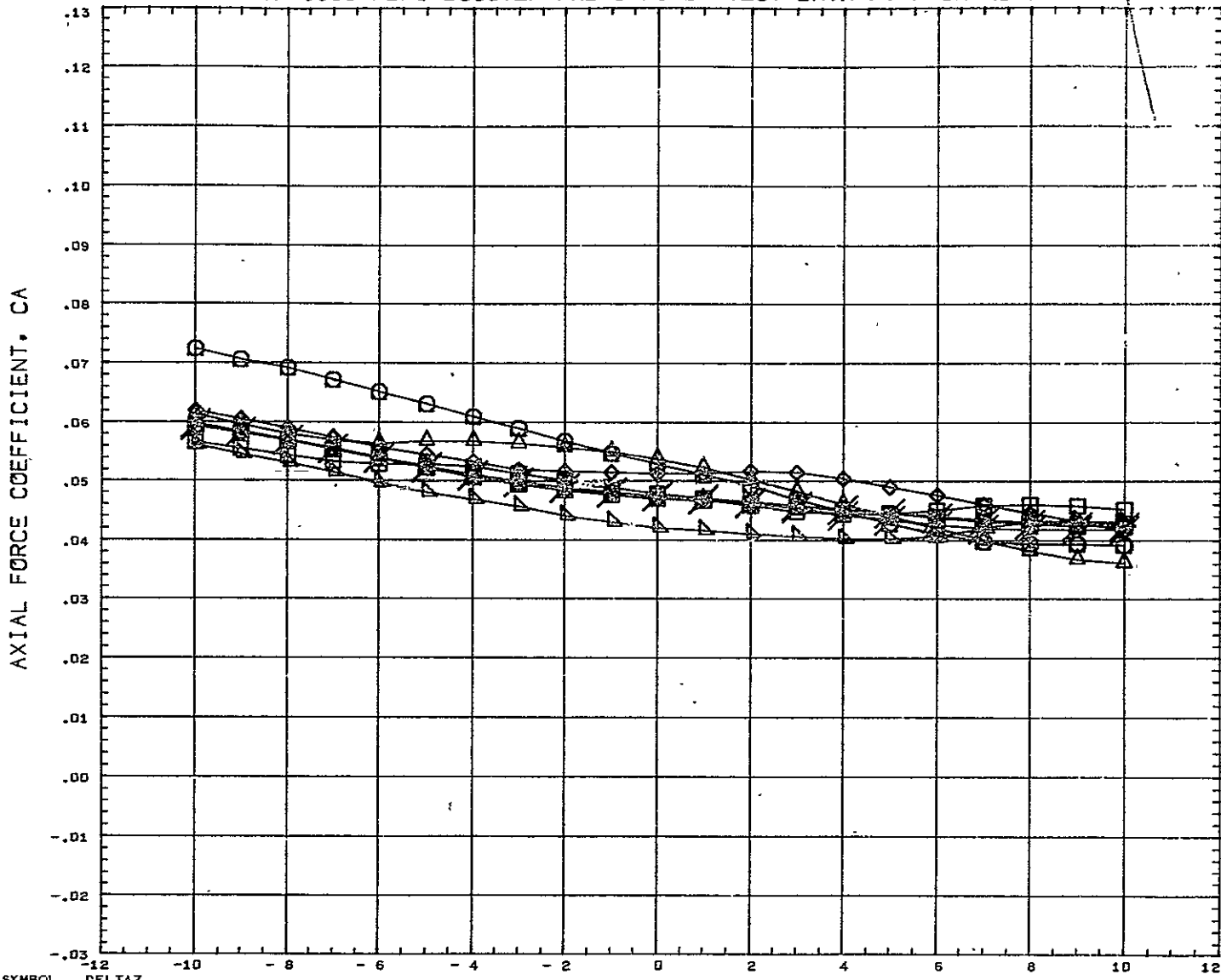

BOOSTER ANGLE OF ATTACK, ALPHAB DEGREES

<p>SYMBOL</p> <p>○</p> <p>◇</p> <p>□</p> <p>△</p> <p>▽</p> <p>◇</p> <p>○</p> <p>◇</p> <p>△</p> <p>▽</p> <p>◇</p> <p>○</p>	<p>DELTAZ</p> <p>0.120</p> <p>0.151</p> <p>0.182</p> <p>0.228</p> <p>0.352</p> <p>0.599</p> <p>0.908</p> <p>10.000</p>	<p style="text-align: center;">PARAMETRIC VALUES</p> <table border="0" style="width: 100%;"> <tr> <td>BSTPOW</td> <td>0.000</td> <td>ORBPOW</td> <td>0.000</td> </tr> <tr> <td>DELTAZ</td> <td>-0.143</td> <td>ALPHA1</td> <td>0.000</td> </tr> <tr> <td>MACH</td> <td>5.020</td> <td>ELVBST</td> <td>0.000</td> </tr> <tr> <td>ELVORB</td> <td>0.000</td> <td>BETA</td> <td>0.000</td> </tr> </table> <p>REFERENCE FILE</p>	BSTPOW	0.000	ORBPOW	0.000	DELTAZ	-0.143	ALPHA1	0.000	MACH	5.020	ELVBST	0.000	ELVORB	0.000	BETA	0.000	<p style="text-align: center;">REFERENCE INFORMATION</p> <table border="0" style="width: 100%;"> <tr> <td>REFS</td> <td>23.6890</td> <td>SQ IN</td> </tr> <tr> <td>REFL</td> <td>4.1930</td> <td>IN</td> </tr> <tr> <td>REFB</td> <td>6.5000</td> <td>IN</td> </tr> <tr> <td>XMRP</td> <td>4.9170</td> <td>IN</td> </tr> <tr> <td>YMRP</td> <td>0.0000</td> <td>IN</td> </tr> <tr> <td>ZMRP</td> <td>1.3900</td> <td>IN</td> </tr> <tr> <td>SCALE</td> <td>0.0055</td> <td></td> </tr> </table>	REFS	23.6890	SQ IN	REFL	4.1930	IN	REFB	6.5000	IN	XMRP	4.9170	IN	YMRP	0.0000	IN	ZMRP	1.3900	IN	SCALE	0.0055	
BSTPOW	0.000	ORBPOW	0.000																																					
DELTAZ	-0.143	ALPHA1	0.000																																					
MACH	5.020	ELVBST	0.000																																					
ELVORB	0.000	BETA	0.000																																					
REFS	23.6890	SQ IN																																						
REFL	4.1930	IN																																						
REFB	6.5000	IN																																						
XMRP	4.9170	IN																																						
YMRP	0.0000	IN																																						
ZMRP	1.3900	IN																																						
SCALE	0.0055																																							

# AEDC VA 1163 MDAC BOOSTER AND ORBITER TEST DATA AT MACH NUMBER 5

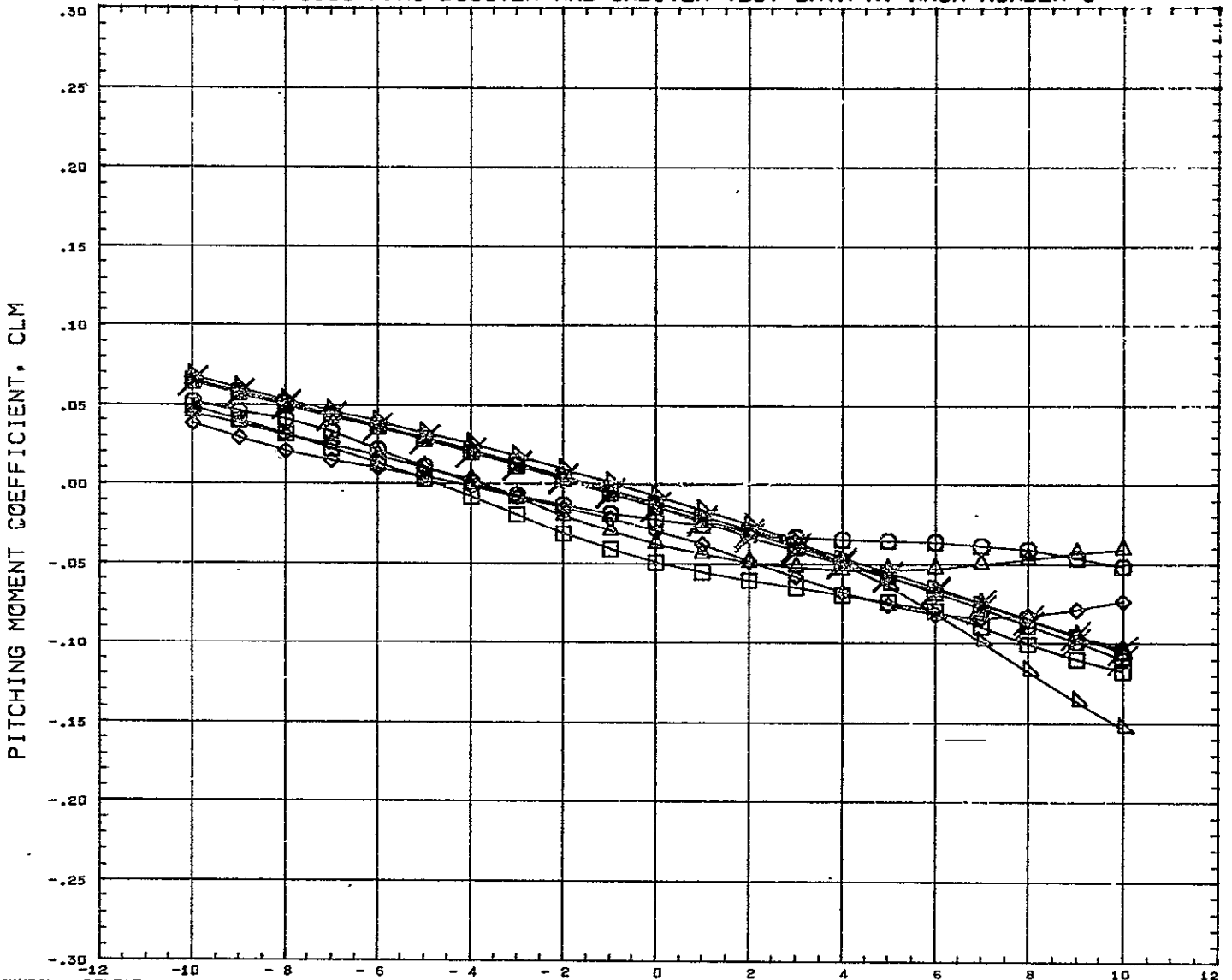

SYMBOL	DELTA Z	PARAMETRIC VALUES				REFERENCE INFORMATION		
◇	0.120					REFS	23.6890	SQ IN
◇	0.151					REFL	4.1930	IN
◇	0.182	BSTFOW	0.000	OREFOW	0.000	REFB	6.5000	IN
◇	0.228	DELTA X	-0.019	ALPHA I	0.000	XMRP	4.9170	IN
◇	0.352	MACH	5.020	ELVBST	0.000	YMRP	0.0000	IN
◇	0.599	ELVORB	0.000	BETA	0.000	ZMRP	1.3900	IN
◇	0.968					SCALE	0.0055	
◇	10.000	REFERENCE FILE						

# AEDC VA 1163 MDAC BOOSTER AND ORBITER TEST DATA AT MACH NUMBER 5

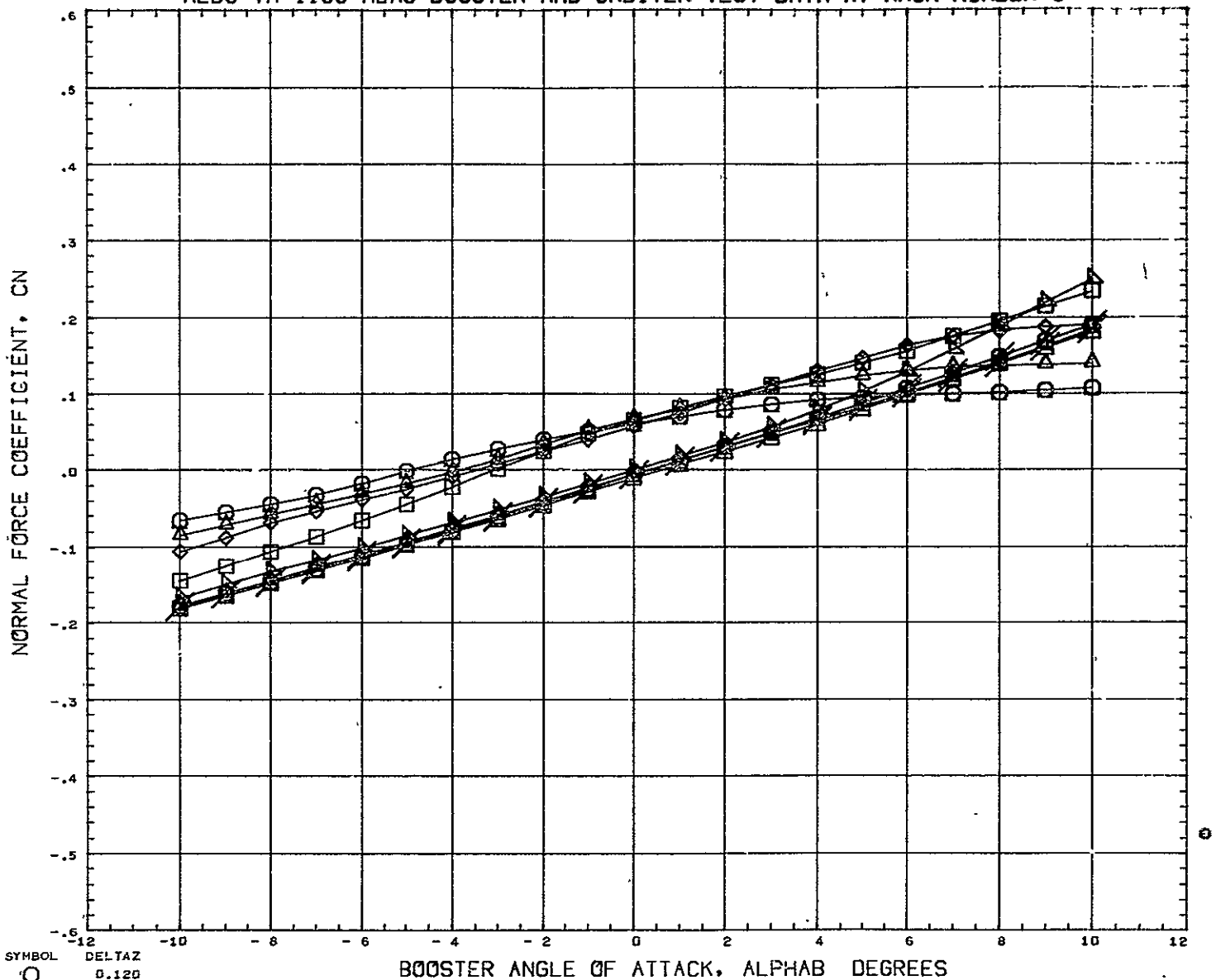

SYMBOL	DELTA Z	PARAMETRIC VALUES				REFERENCE INFORMATION		
○	0.120							
◇	0.151							
□	0.182	BSTPOW	0.000	ORBPOW	0.000	REFS	23.6890	SQ IN
△	0.228	DELTA X	- 0.019	ALPHA I	0.000	REFL	4.1930	IN
▽	0.352	MACH	5.020	ELVBST	0.000	REFB	6.5000	IN
◇	0.599	ELVORB	0.000	BETA	0.000	XMRP	4.9170	IN
◇	0.908					YMRP	0.0000	IN
◇	10.000	REFERENCE FILE				ZMRP	1.3900	IN
						SCALE	0.0055	

# AEDC VA 1163 MDAC BOOSTER AND ORBITER TEST DATA AT MACH NUMBER 5

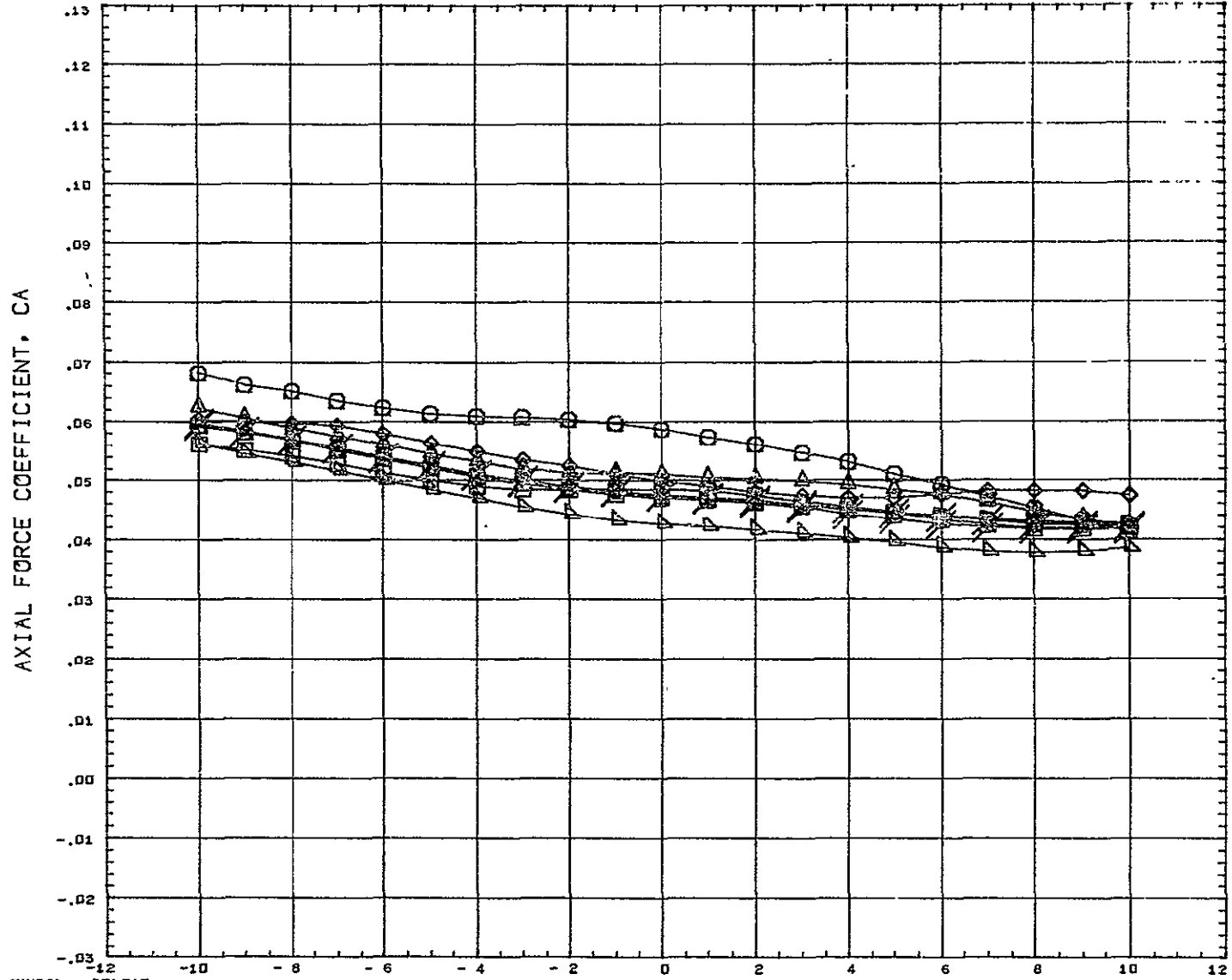

SYMBOL <del>○</del> <del>△</del> <del>◇</del> <del>□</del> <del>◇</del> <del>△</del> <del>○</del>	DELTAZ 0.120 0.151 0.182 0.228 0.352 0.599 0.908 10.000	<b>PARAMETRIC VALUES</b> BSTPOW    0.000    ORBPOW    0.000 DELTAX    - 0.019    ALPHAI    0.000 MACH       5.020    ELVBST    0.000 ELVORB    0.000    BETA       0.000	<b>REFERENCE INFORMATION</b> REFS       23.6890    SQ IN REFL       4.1930    IN REFB       6.5000    IN XMRP       4.9170    IN YMRP       0.0000    IN ZMRP       1.3900    IN SCALE       0.0055
10.000    REFERENCE FILE			

# AEDC VA 1163 MDAC BOOSTER AND ORBITER TEST DATA AT MACH NUMBER 5

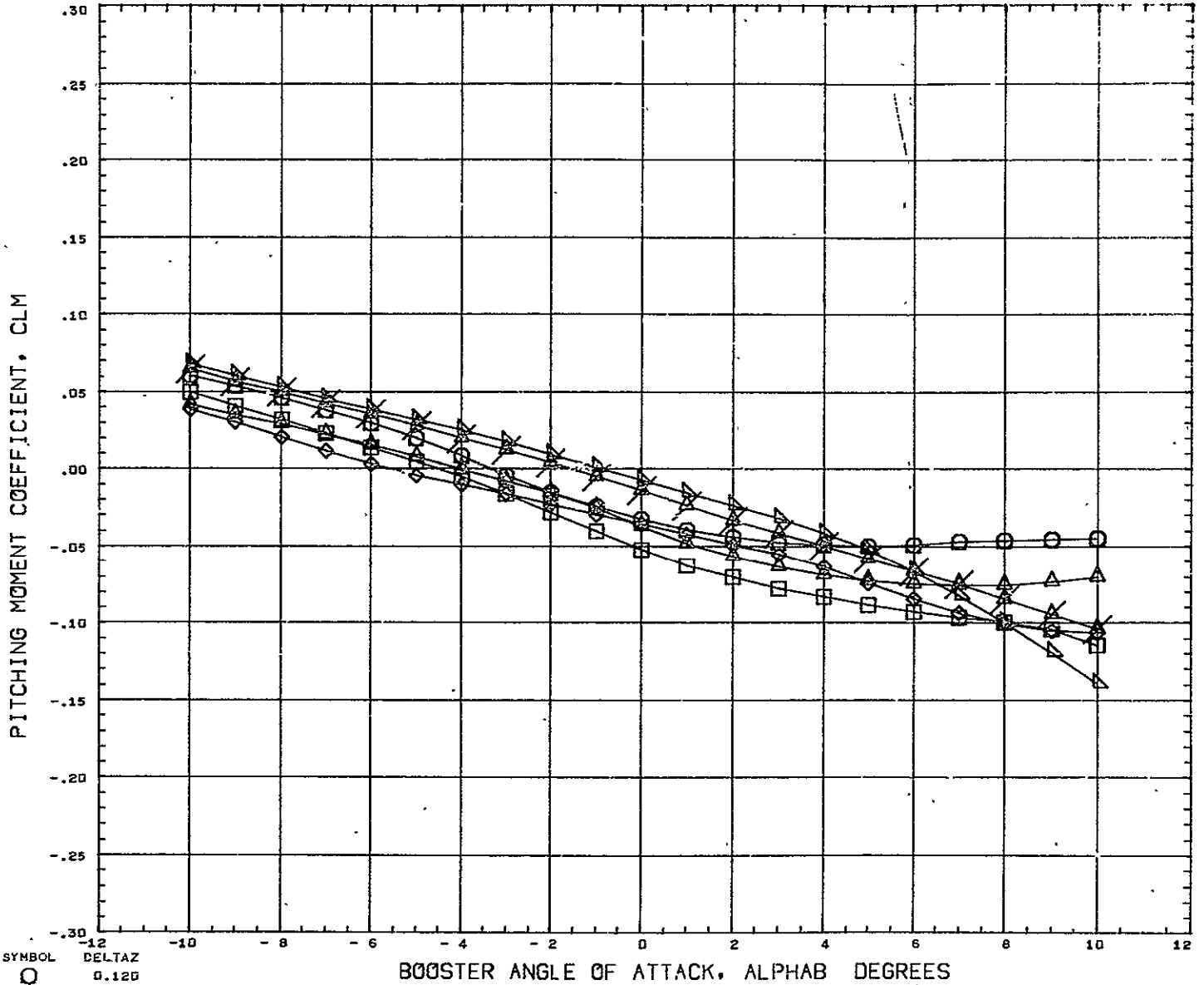

SYMBOL	DELTA Z
○	0.120
◇	0.151
◇	0.182
◇	0.228
◇	0.352
◇	10.000

PARAMETRIC VALUES			
BSTPOW	0.000	ORBPOW	0.000
DELTA Z	0.043	ALPHA I	0.000
MACH	5.020	ELVBST	0.000
ELVORB	0.000	BETA	0.000

REFERENCE INFORMATION		
REFS	23.6890	SQ IN
REFL	4.1930	IN
REFB	6.5000	IN
XMRP	4.9170	IN
YMRP	0.0000	IN
ZMRP	1.3900	IN
SCALE	0.0055	

REFERENCE FILE



# AEDC VA 1163 MDAC BOOSTER AND ORBITER TEST DATA AT MACH NUMBER 5

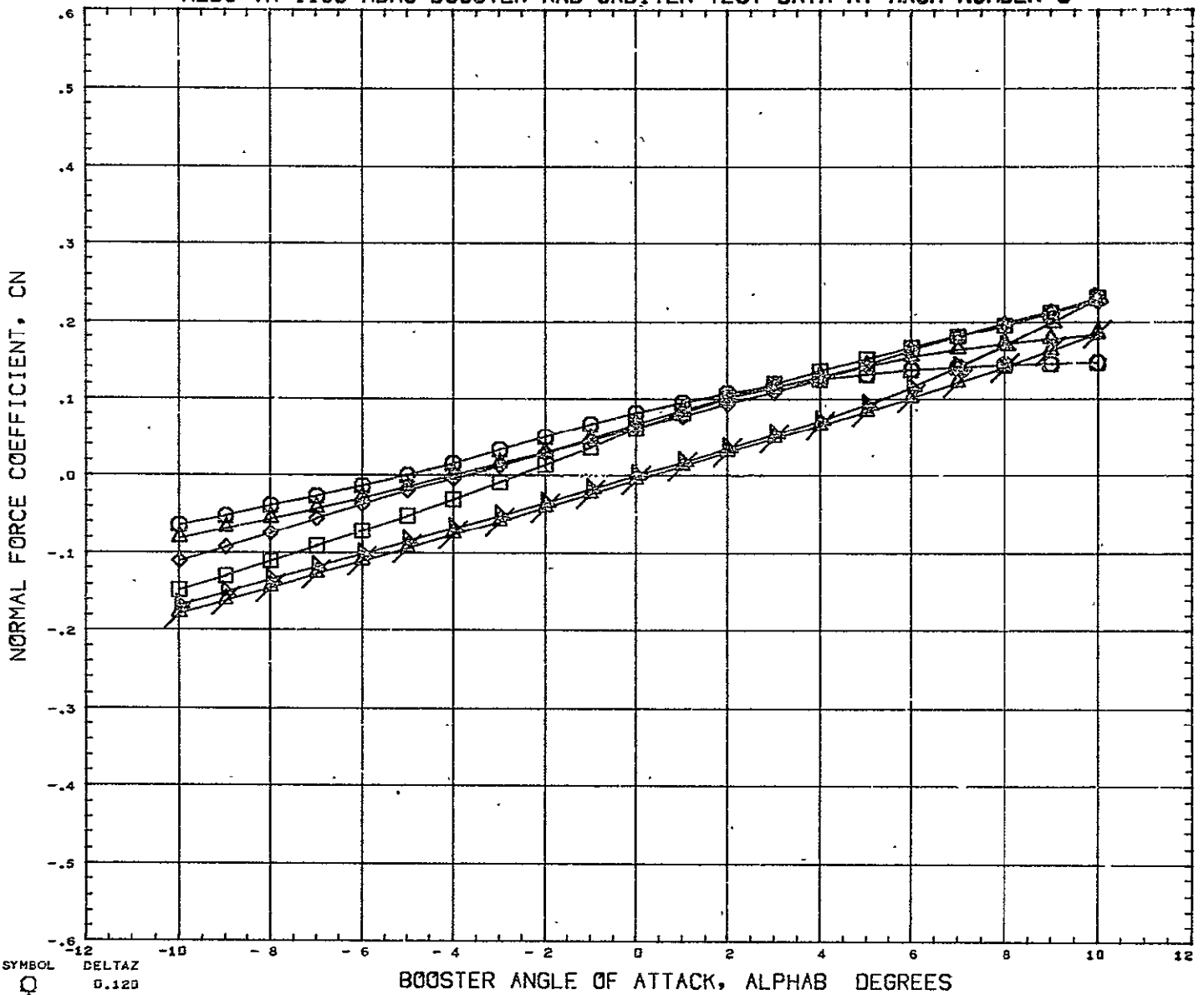

SYMBOL ○ ◇ □ ▲ ▼	DELTA Z 0.120 0.151 0.182 0.228 0.352 10.000	PARAMETRIC VALUES BSTPOW 0.000 ORBPOW 0.000 DELTAX 0.043 ALPHAI 0.000 MACH 5.020 ELVBST 0.000 ELVORB 0.000 BETA 0.000	REFERENCE INFORMATION REFS 23.6890 SQ IN REFL 4.1930 IN REFB 6.5000 IN YMRP 4.9170 IN YMRP 0.0000 IN ZMRP 1.3900 IN SCALE 0.0055
---------------------------------	--	---	---

REFERENCE FILE

# AEDC VA 1163 MDAC BOOSTER AND ORBITER TEST DATA AT MACH NUMBER 5

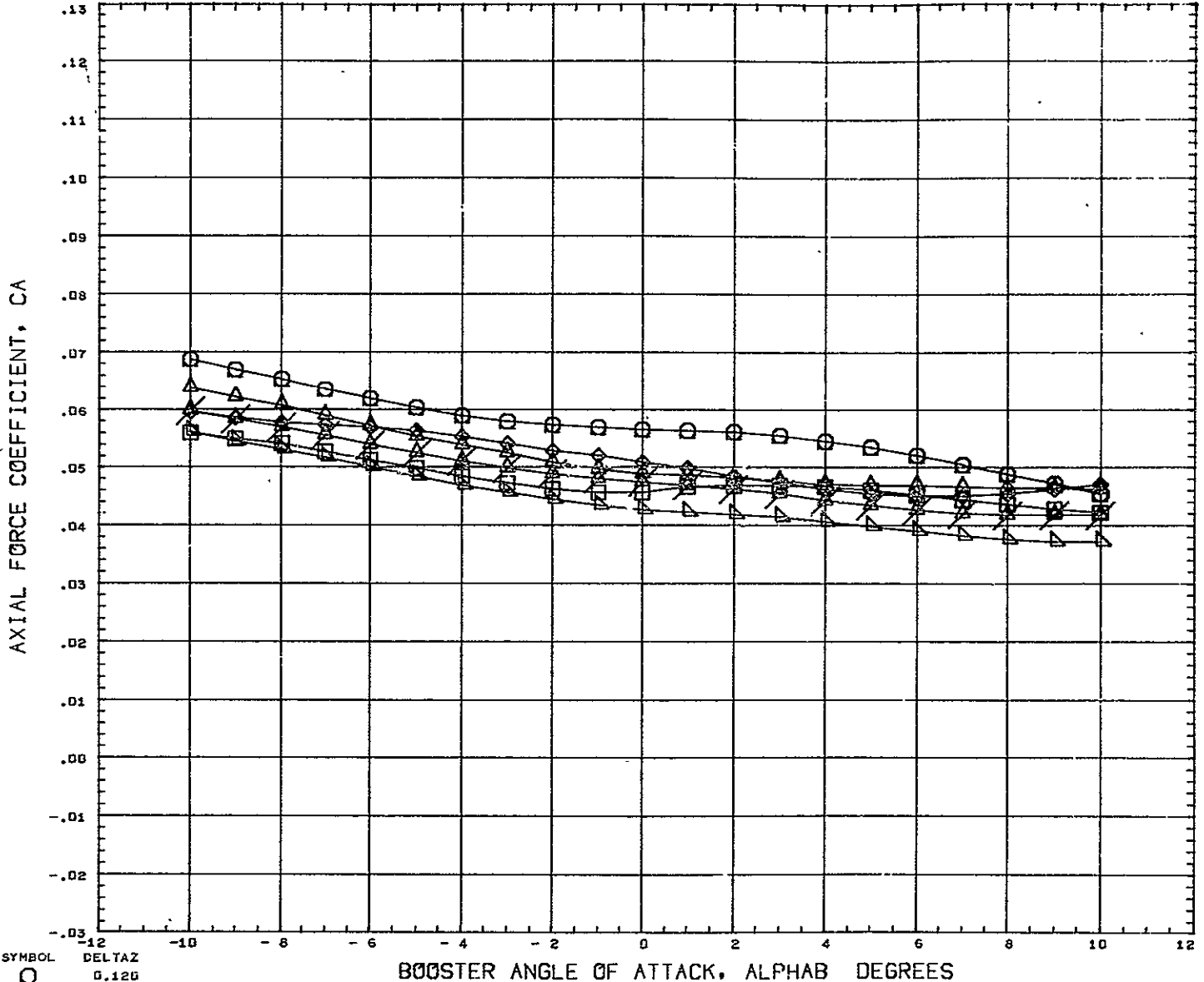

SYMBOL ○ ◇ □ △	DELTAZ 0.120 0.151 0.182 0.228 0.352 10.000	PARAMETRIC VALUES BSTPOW 0.000 ORBPOW 0.000 ELTAX 0.043 ALPHA1 0.000 MACH 5.020 ELVBST 0.000 ELVORB 0.000 BETA 0.000	REFERENCE INFORMATION REFS 23.6890 SQ IN REFL 4.1930 IN REFB 6.5000 IN XMRP 4.9170 IN YMRP 0.0000 IN ZMRP 1.3900 IN SCALE 0.0055
----------------------------	---	--	---

REFERENCE FILE

# AEDC VA 1163 MDAC BOOSTER AND ORBITER TEST DATA AT MACH NUMBER 5

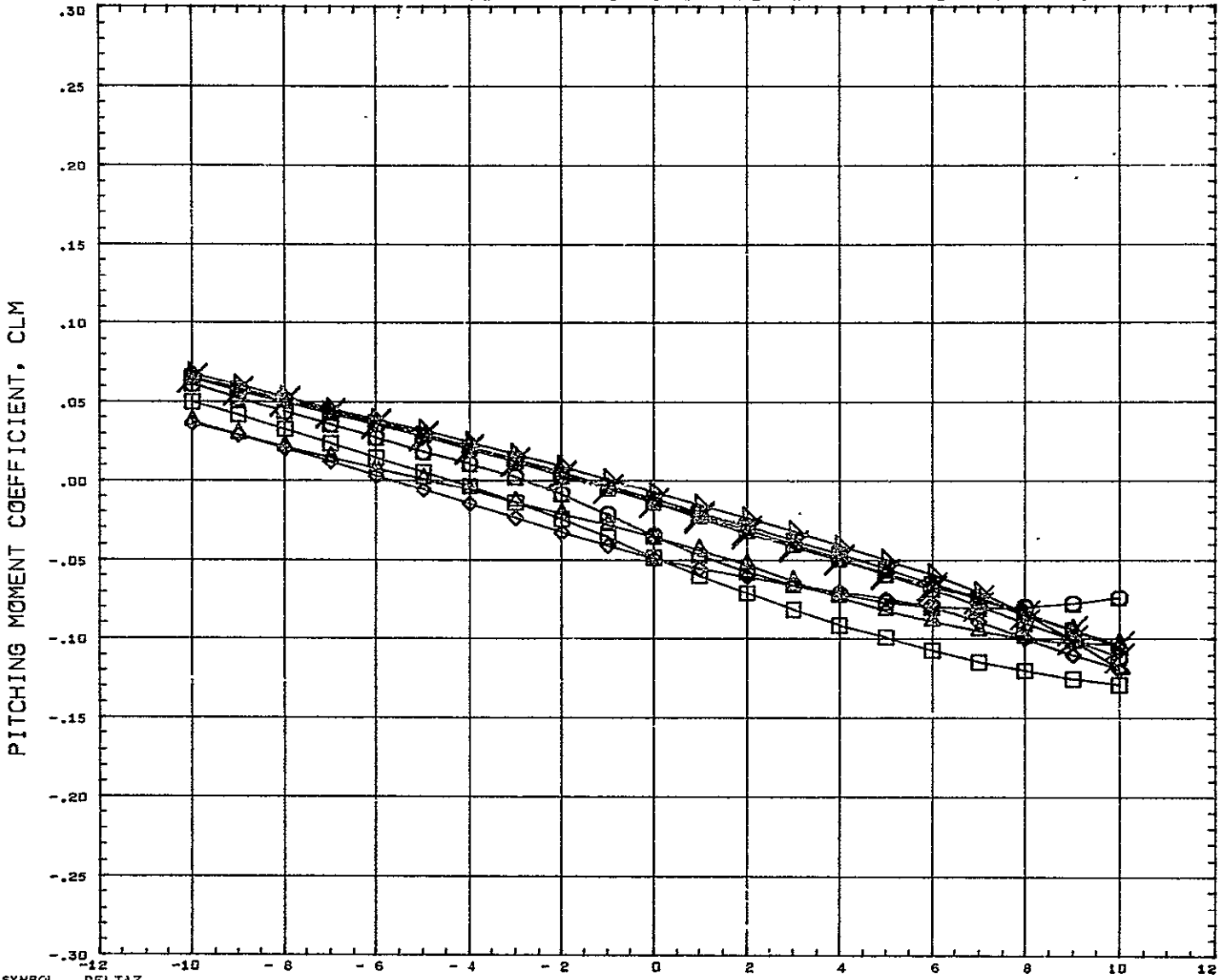

SYMBOL ◇ ◻ △ × * ○ + ○	DELTA Z 0.120 0.151 0.182 0.228 0.352 0.599 0.908 10.000	PARAMETRIC VALUES BSTPOW 0.000 ORBPOW 0.000 DELTAX 0.105 ALPHA1 0.000 MACH 5.020 ELVBST 0.000 ELVORB 0.000 BETA 0.000 REFERENCE FILE	REFERENCE INFORMATION REFS 23.6890 SQ IN REFL 4.1930 IN REFB 6.5000 IN XMRP 4.9170 IN YMRP 0.0000 IN ZMRP 1.3900 IN SCALE 0.0055
--	--	---	---

# AEDC VA 1163 MDAC BOOSTER AND ORBITER TEST DATA AT MACH NUMBER 5

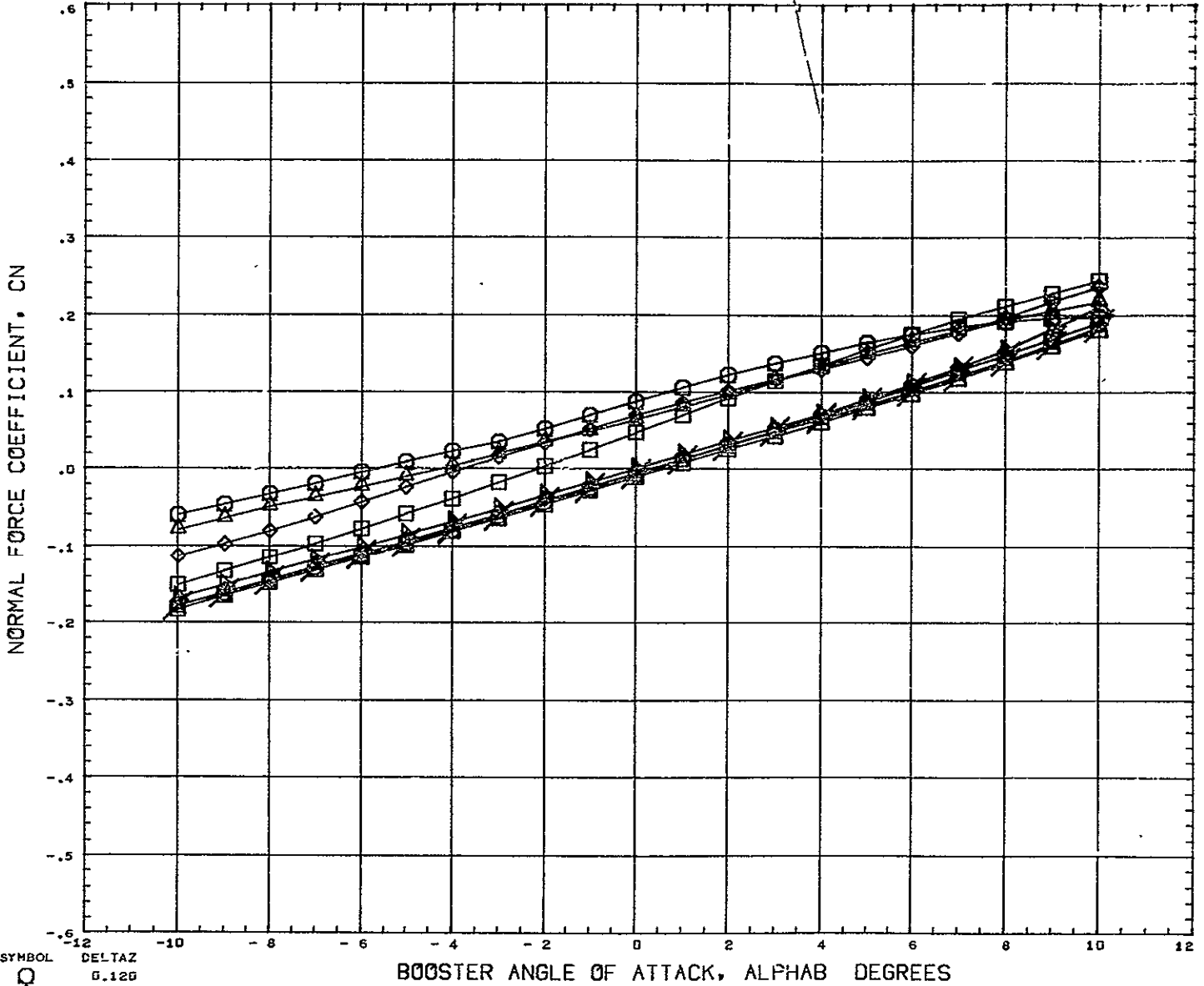

SYMBOL ○ □ △ ◇ ×	DELTAZ 0.120 0.151 0.182 0.228 0.352 0.599 0.908 10.000	<b>PARAMETRIC VALUES</b> BSTFOW    0.000    ORBPOW    0.000 DELTAX    0.105    ALPHAI    0.000 MACH       5.020    ELVBST    0.000 ELVORB    0.000    BETA       0.000	<b>REFERENCE INFORMATION</b> REFS       23.6890    SQ IN REFL       4.1930    IN REFB       6.5000    IN XMRP       4.9170    IN YMRP       0.0000    IN ZMRP       1.3900    IN SCALE      0.0055
	<b>BOOSTER ANGLE OF ATTACK, ALPHAB DEGREES</b>		

# AEDC VA 1163 MDAC BOOSTER AND ORBITER TEST DATA AT MACH NUMBER 5

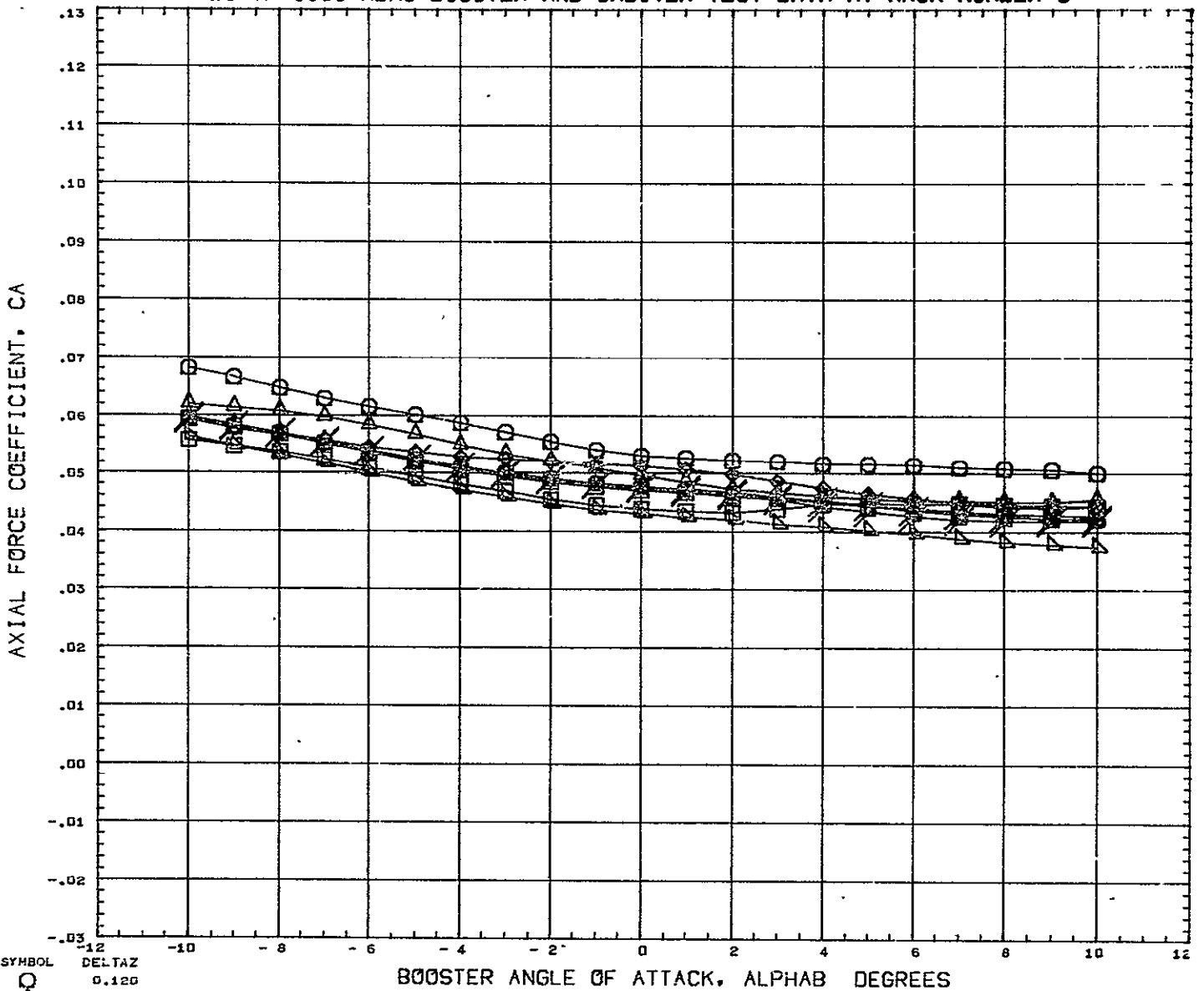

SYMBOL $\square$ $\triangle$ $\diamond$ $\square$ $\triangle$ $\diamond$ $\square$ $\triangle$ $\diamond$ $\square$ $\triangle$ $\diamond$	DELTA Z 0.120 0.151 0.182 0.228 0.352 0.599 0.908 10.000	PARAMETRIC VALUES BSTPOW 0.000 ORBPOW 0.000 DELTAX 0.105 ALPHAI 0.000 MACH 5.020 ELVBST 0.000 ELVORB 0.000 BETA 0.000 REFERENCE FILE	REFERENCE INFORMATION REFS 23.6890 SQ IN REFL 4.1930 IN REFB 6.5000 IN XMRF 4.9170 IN YMRF 0.0000 IN ZMRF 1.3900 IN SCALE 0.0055
--	--	---	---

# AEDC VA 1163 MDAC BOOSTER AND ORBITER TEST DATA AT MACH NUMBER 5

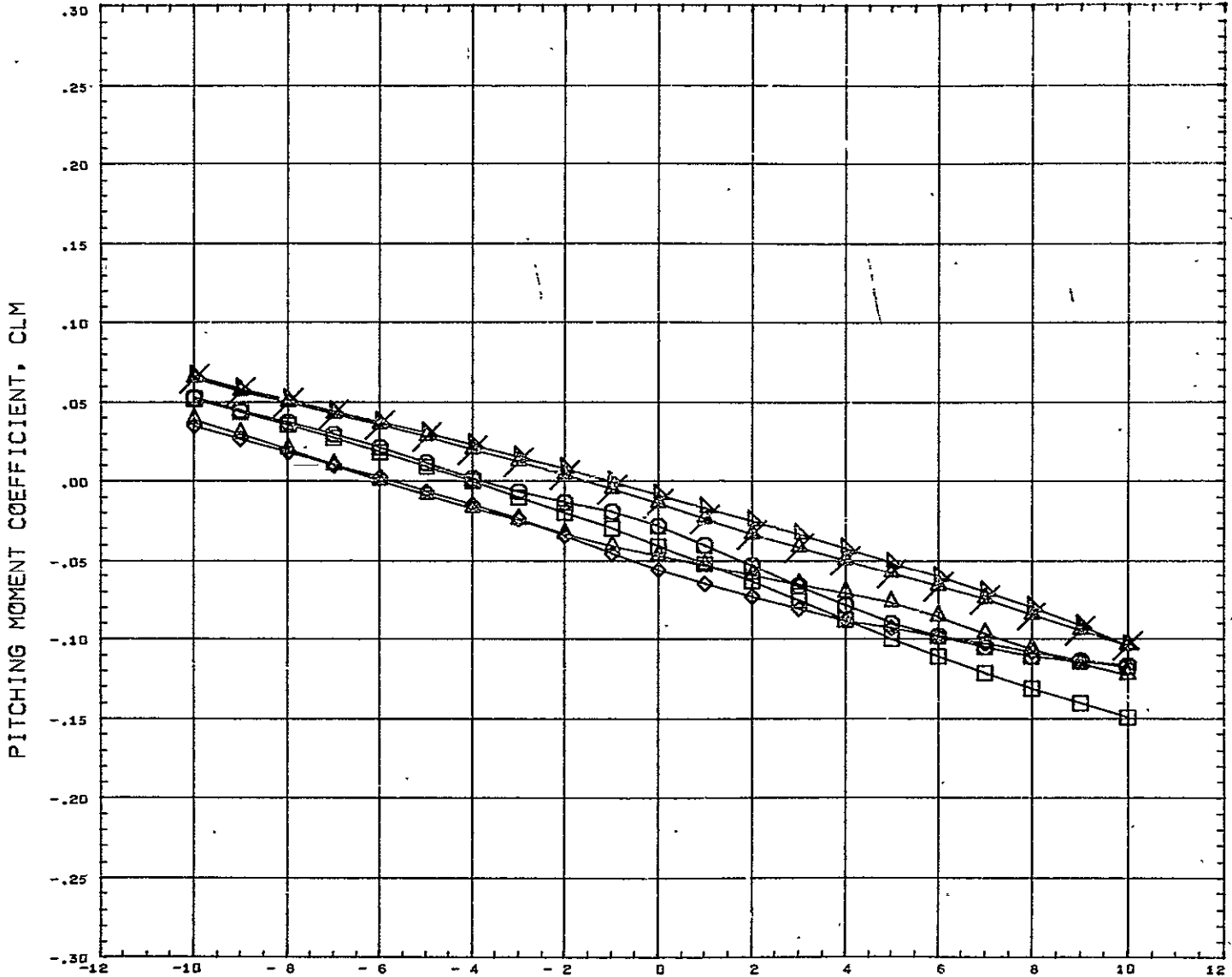

SYMBOL 	DELTAX 0.120 0.151 0.182 0.228 0.352 10.000	PARAMETRIC VALUES BSTFOW 0.000 ORBPOW 0.000 JELTAX 0.167 ALPHAI 0.000 MACH 5.020 ELVBST 0.000 ELVORB 0.000 BETA 0.000	REFERENCE INFORMATION REFS 23.6890 SQ IN REFL 4.1930 IN REFB 6.5000 IN XMRP 4.9179 IN YMRP 0.0000 IN ZMRP 1.3900 IN SCALE 0.0055
------------	---	---	---

REFERENCE FILE

# AEDC VA 1163 MDAC BOOSTER AND ORBITER TEST DATA AT MACH NUMBER 5

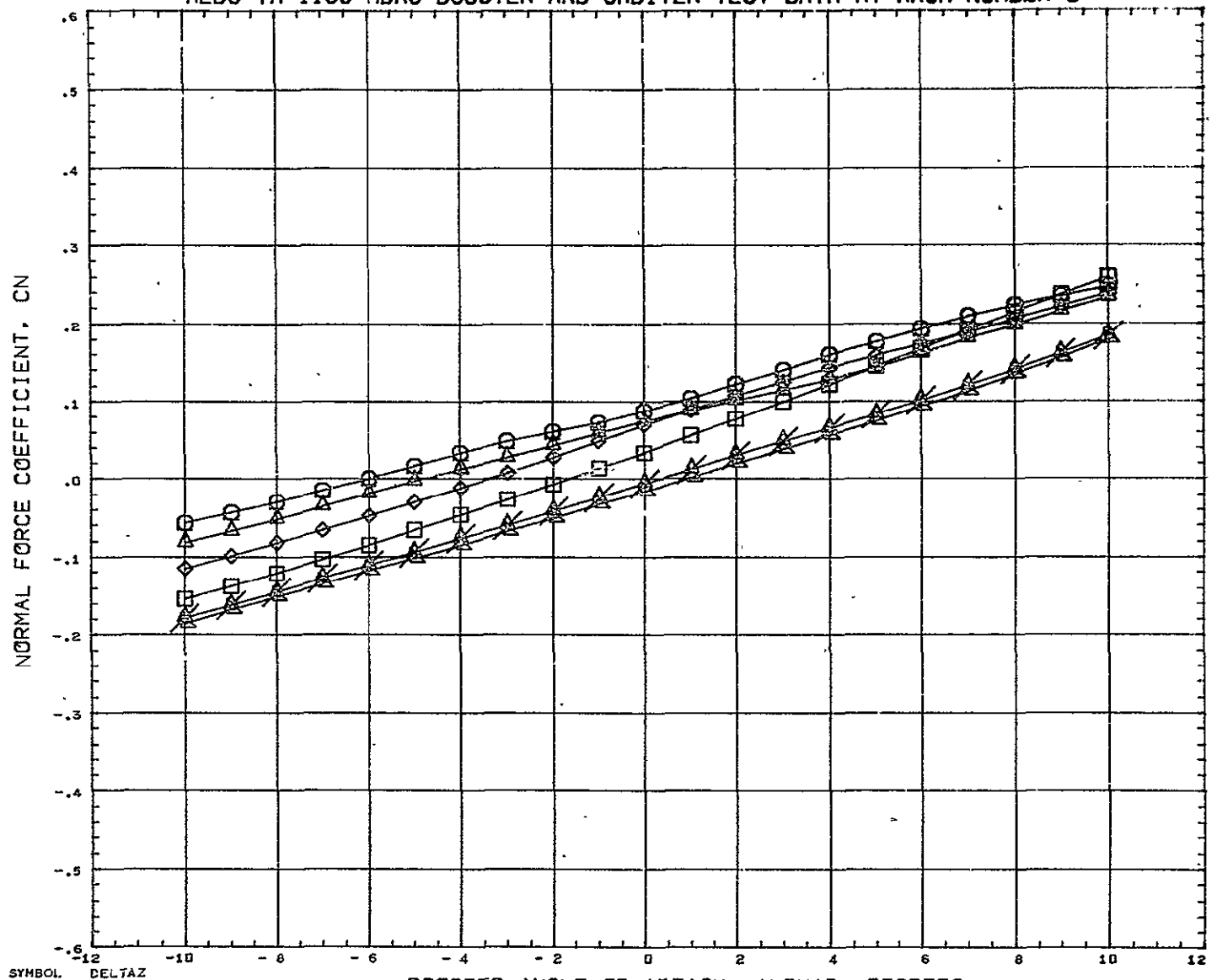

SYMBOL ○ ◇ □ △	DELTAZ 0.120 0.151 0.182 0.228 0.352 10.000	PARAMETRIC VALUES BSTPOW    0.000    ORBPOW    0.000 LELTAX    0.167    ALPHAI    0.000 MACH       5.020    ELVBST    0.000 ELVORB    0.000    BETA       0.000	REFERENCE INFORMATION REFS       23.6890    SQ IN REFL       4.1930    IN REFB       6.5000    IN XMRP       4.9175    IN YHRP       0.0000    IN ZMRP       1.3900    IN SCALE       0.0055
----------------------------	---	---	---

REFERENCE FILE

# AEDC VA 1163 MDAC BOOSTER AND ORBITER TEST DATA AT MACH NUMBER 5

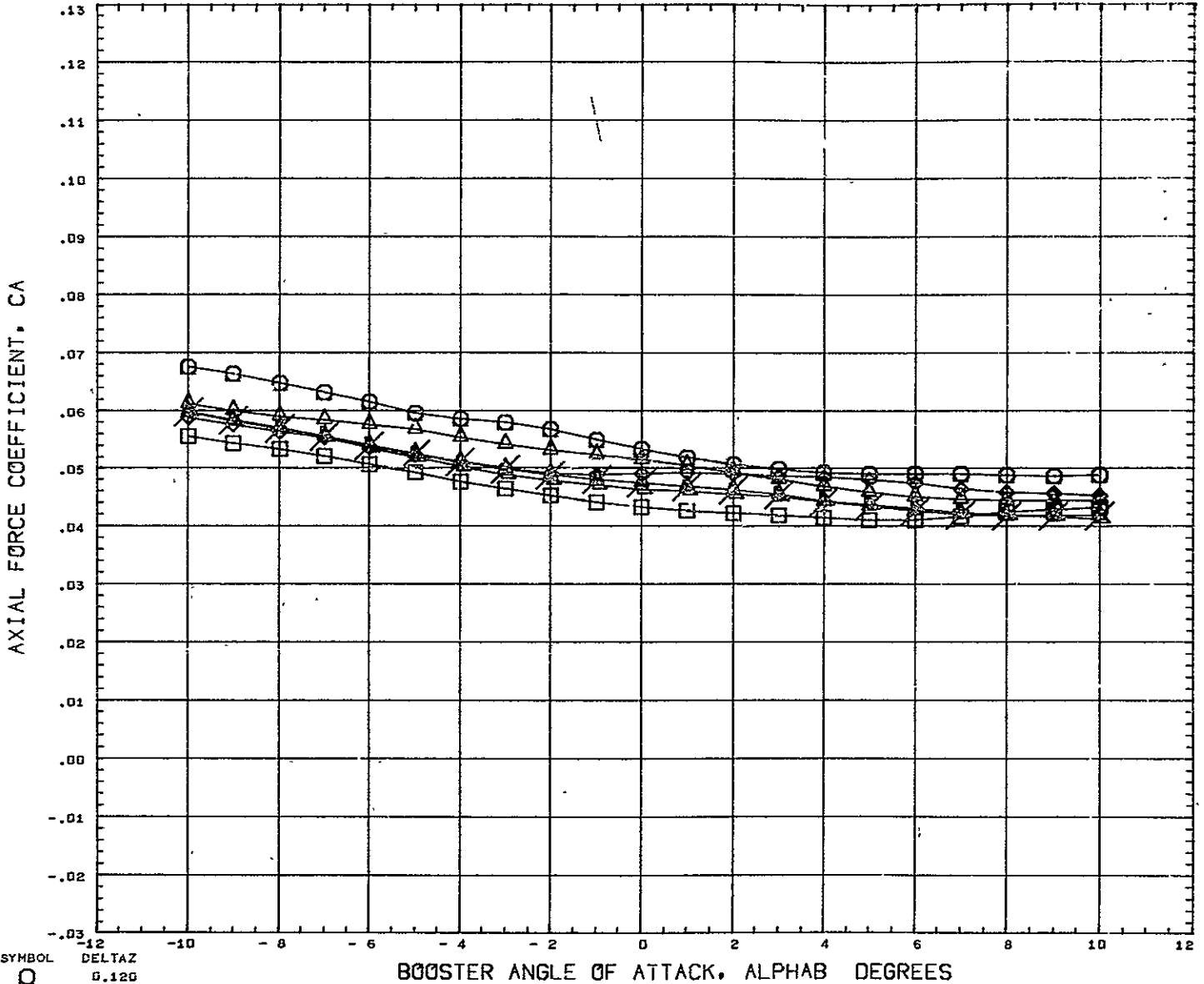

SYMBOL	DELTAZ	PARAMETRIC VALUES			
○	0.120	BSTPOW	0.000	ORBPOW	0.000
△	0.151	DELTAZ	0.167	ALPHA1	0.000
◇	0.182	MACH	5.020	ELVBST	0.000
□	0.228	ELVORB	0.000	BETA	0.000
△	0.352				
△	10.000				

REFERENCE INFORMATION		
REFS	23.6890	50 IN
REFL	4.1930	IN
REFB	6.5000	IN
XMRP	4.9170	IN
YMRP	0.0000	IN
ZMRP	1.3900	IN
SCALE	0.0055	

REFERENCE FILE



# AEDC VA 1163 MDAC BOOSTER AND ORBITER TEST DATA AT MACH NUMBER 5

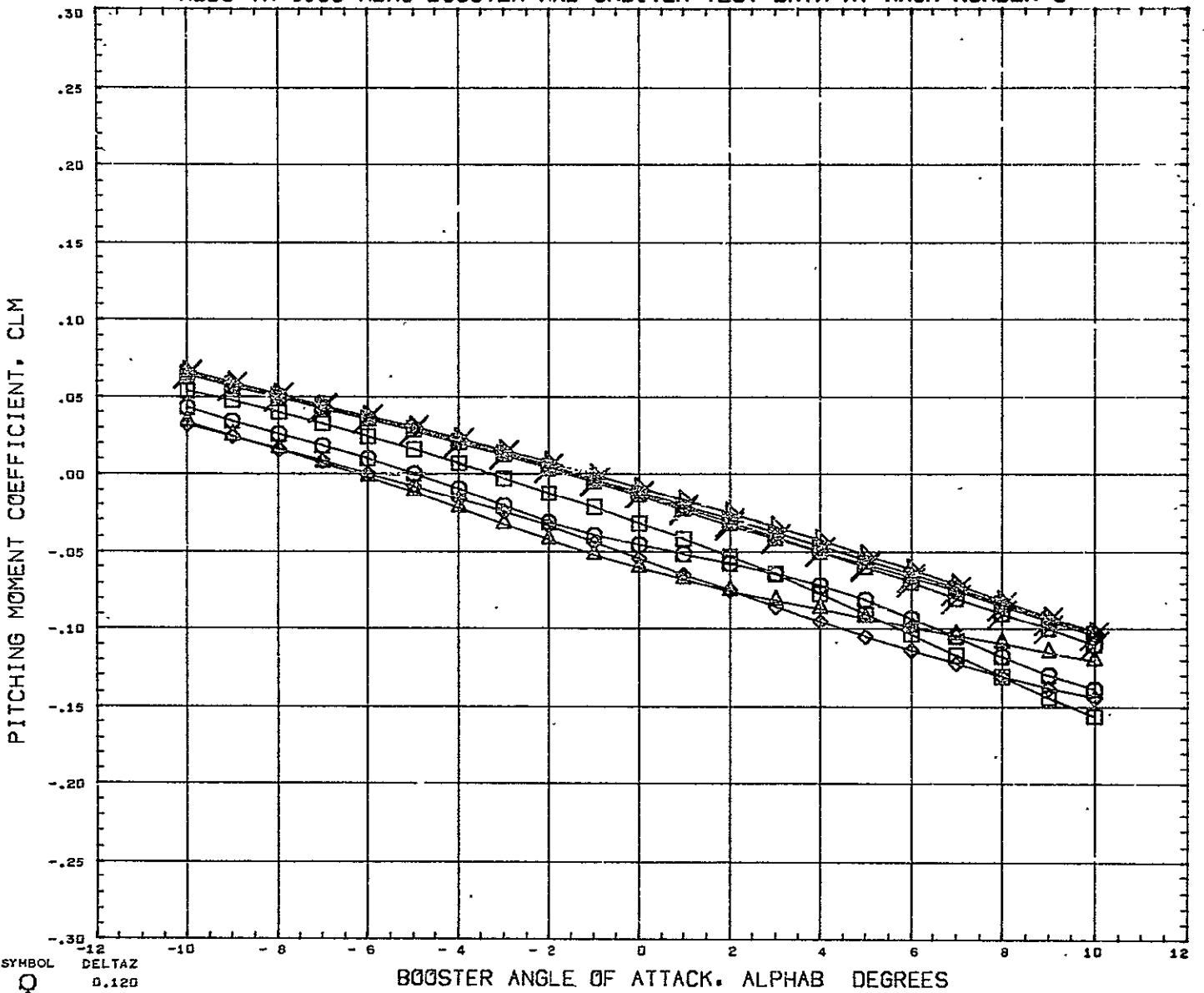

SYMBOL	DELTA Z	PARAMETRIC VALUES	REFERENCE INFORMATION
○	0.120		
◇	0.151		
△	0.182	BSTPOW 0.000 ORBPOW 0.000	REFS 23.6890 SQ IN
□	0.228	JELTAX 0.228 ALPHAI 0.000	REFL 4.1930 IN
▽	0.352	MACH 5.020 ELVBST 0.000	REFB 6.5000 IN
◇	0.599	ELVORB 0.000 BETA 0.000	XMRP 4.9170 IN
◇	0.908		YMRP 0.0000 IN
◇	10.000	REFERENCE FILE	ZMRP 1.3900 IN
			SCALE 0.0055

# AEDC VA 1163 MDAC BOOSTER AND ORBITER TEST DATA AT MACH NUMBER 5

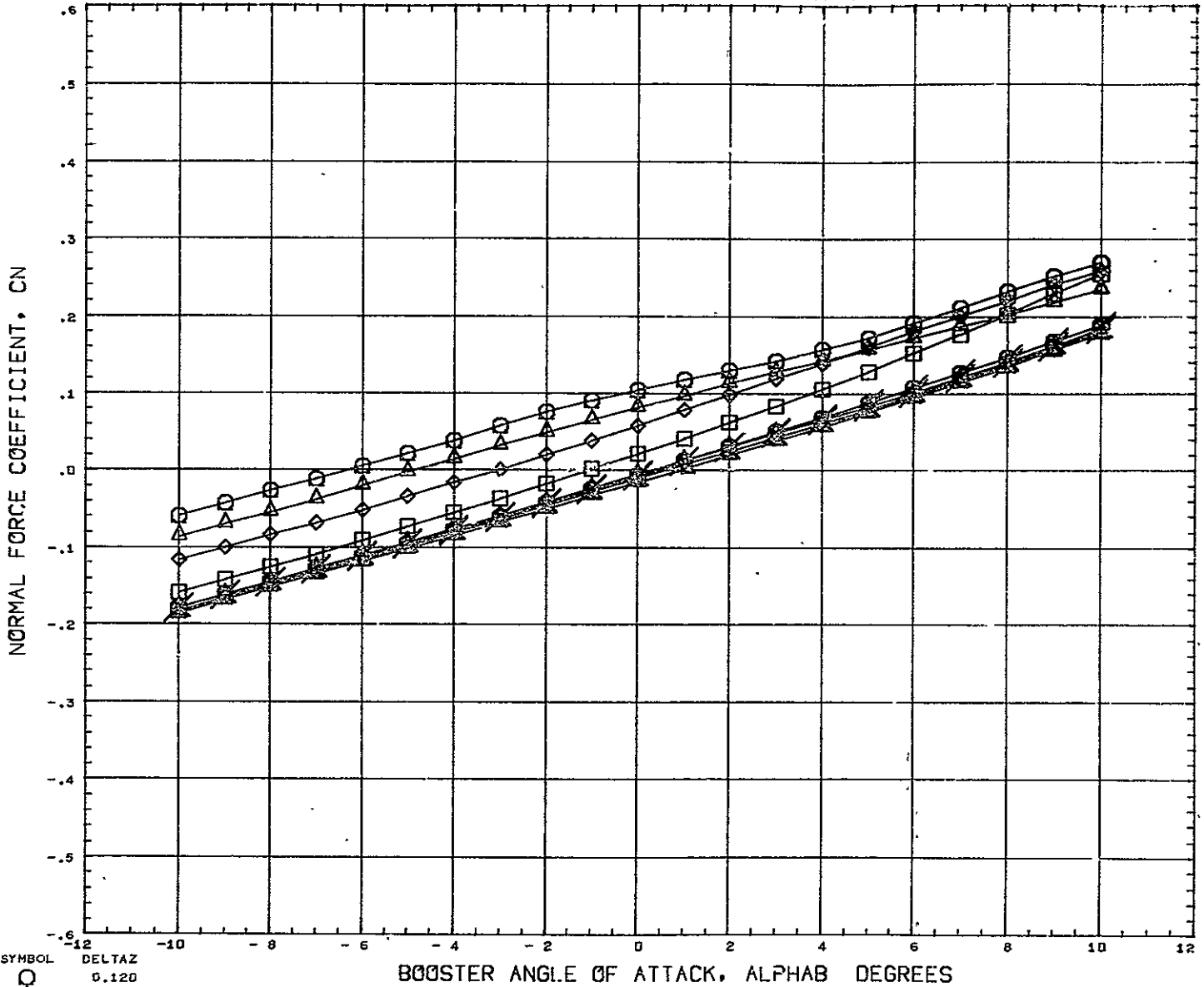

SYMBOL <del>○</del> <del>□</del> <del>◇</del> <del>△</del> <del>▽</del> <del>◇</del> <del>○</del>	DELTAZ 0.120 0.151 0.182 0.228 0.352 0.599 0.908 10.000	<b>PARAMETRIC VALUES</b> BSTPOW    0.000    CRBPOW    0.000 DELTAX    0.228    ALPHAI    0.000 MACH       5.020    ELVBST    0.000 ELVORB    0.000    BETA       0.000	<b>REFERENCE INFORMATION</b> REFS       23.6890    SQ IN REFL       4.1930    IN REFB       6.5000    IN XMRF       4.9179    IN YMRF       0.0000    IN ZMRF       1.3900    IN SCALE      0.0055
	REFERENCE FILE		

# AEDC VA 1163 MDAC BOOSTER AND ORBITER TEST DATA AT MACH NUMBER 5

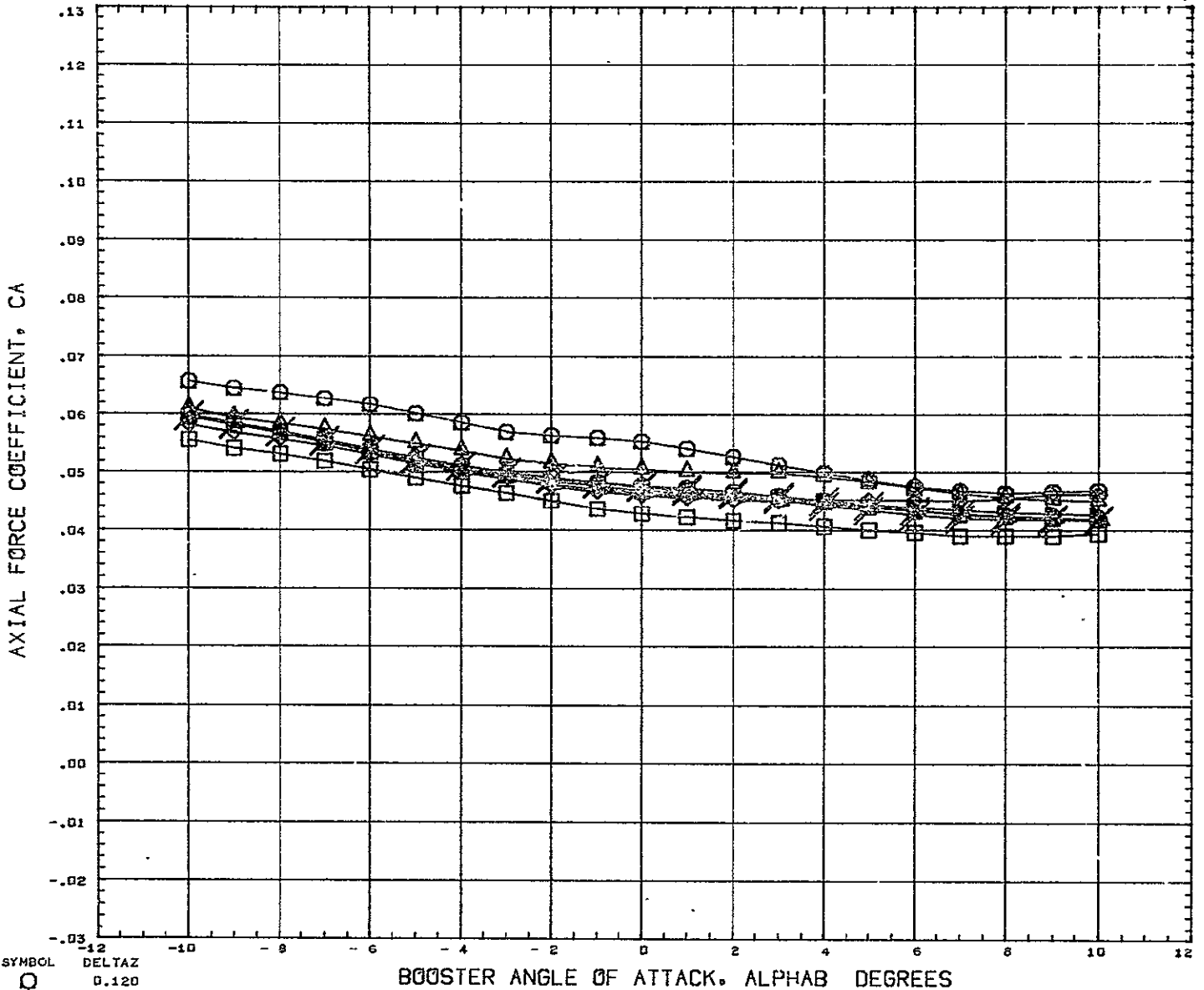

SYMBOL $\square$ $\diamond$ $\triangle$ $\square$ $\square$ $\square$ $\square$ $\square$ $\square$ $\square$	DELTAZ 0.120 0.151 0.102 0.228 0.352 0.599 0.908 10.000	PARAMETRIC VALUES BSTPOW 0.000 ORBPOW 0.000 JELTAX 0.228 ALPHAI 0.000 MACH 5.020 ELVBST 0.000 ELVORB 0.000 BETA 0.000 REFERENCE FILE	REFERENCE INFORMATION REFS 23.6890 SQ IN REFL 4.1930 IN REFB 6.5000 IN XMRF 4.9170 IN YMRP 0.0000 IN ZMRP 1.3900 IN SCALE 0.0055
---	---	---	---

# AEDC VA 1163 MDAC BOOSTER AND ORBITER TEST DATA AT MACH NUMBER 5

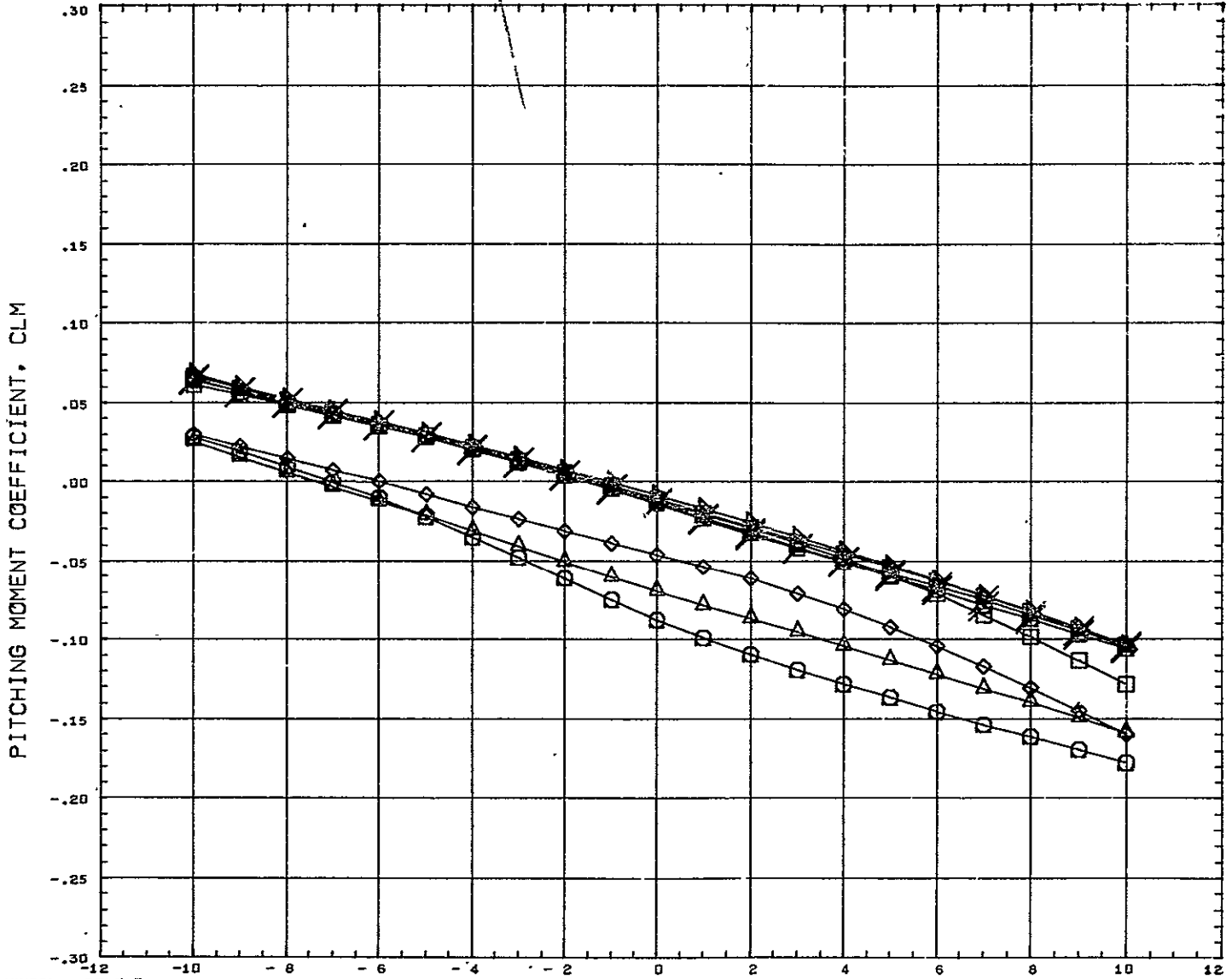

SYMBOL ○ □ △ ◇ ☆ ○	DELTAX 0.120 0.151 0.182 0.228 0.352 0.599 0.908 10.000	PARAMETRIC VALUES BSTFOW 0.000 ORBPOW 0.000 JELTAX 0.351 ALPHAI 0.000 MACH 5.020 ELVBST 0.000 ELVORB 0.000 BETA 0.000	REFERENCE INFORMATION REFS 23.6890 SQ IN REFL 4.1930 IN REFB 6.5000 IN XMRF 4.9170 IN YMRP 0.0000 IN ZMRP 1.3900 IN SCALE 0.0055
		BOOSTER ANGLE OF ATTACK, ALPHAB DEGREES	

# AEDC VA 1163 MDAC BOOSTER AND ORBITER TEST DATA AT MACH NUMBER 5

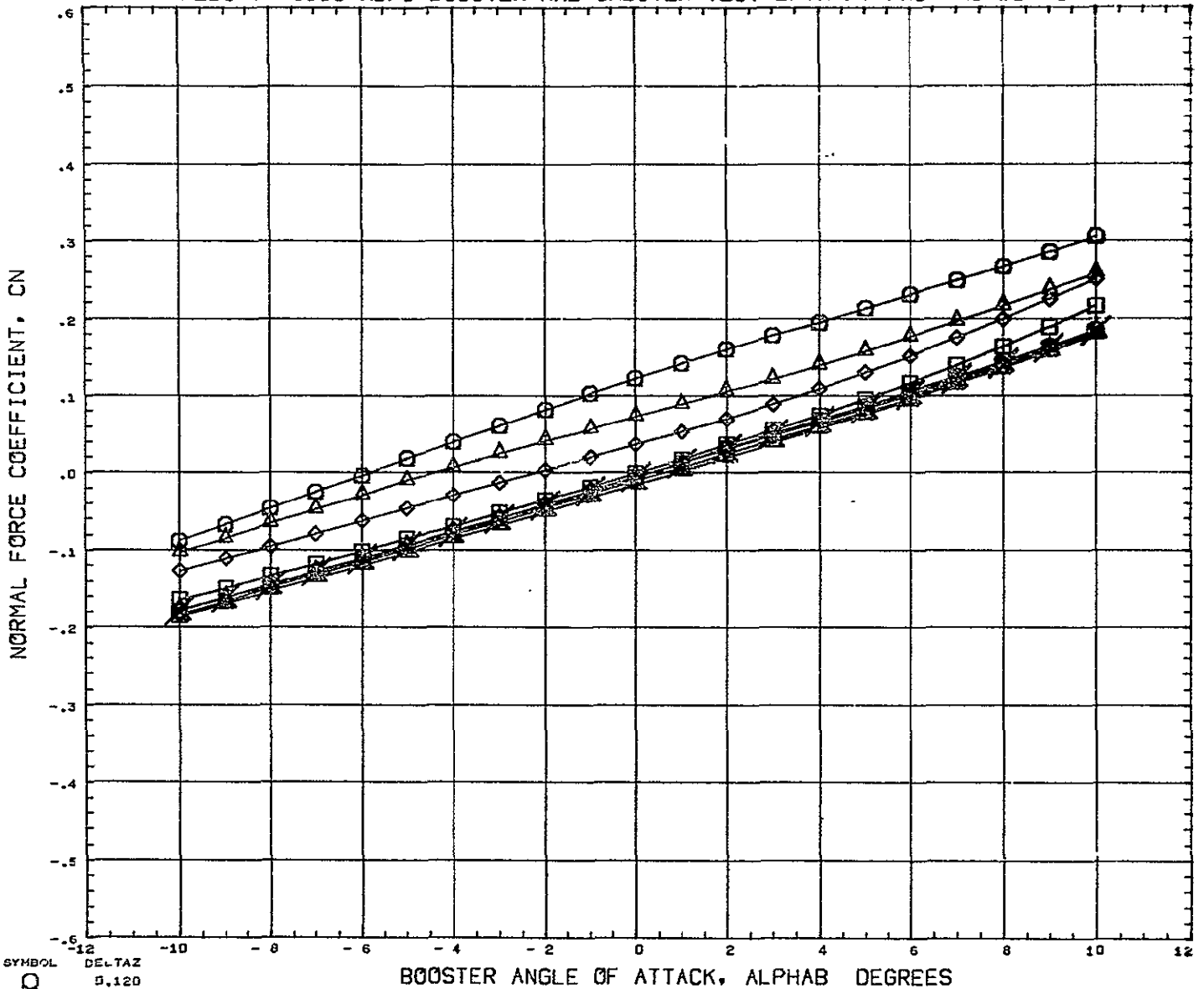

SYMBOL	DELTA Z	PARAMETRIC VALUES				REFERENCE INFORMATION		
○	0.120							
◇	0.151							
△	0.182	BSTPOW	0.000	ORBPOW	0.000	REFS	23.6890	SQ IN
□	0.228	DELTA X	0.351	ALPHA I	0.000	REFL	4.1930	IN
◇	0.352	MACH	5.020	ELVBST	0.000	REFB	6.5000	IN
△	0.599	ELVORB	0.000	BETA	0.070	XMRP	4.9170	IN
◇	0.908					YMRP	0.0000	IN
◇	10.000	REFERENCE FILE				ZMRP	1.3900	IN
						SCALE	0.0015	

# AEDC VA 1163 MDAC BOOSTER AND ORBITER TEST DATA AT MACH NUMBER 5

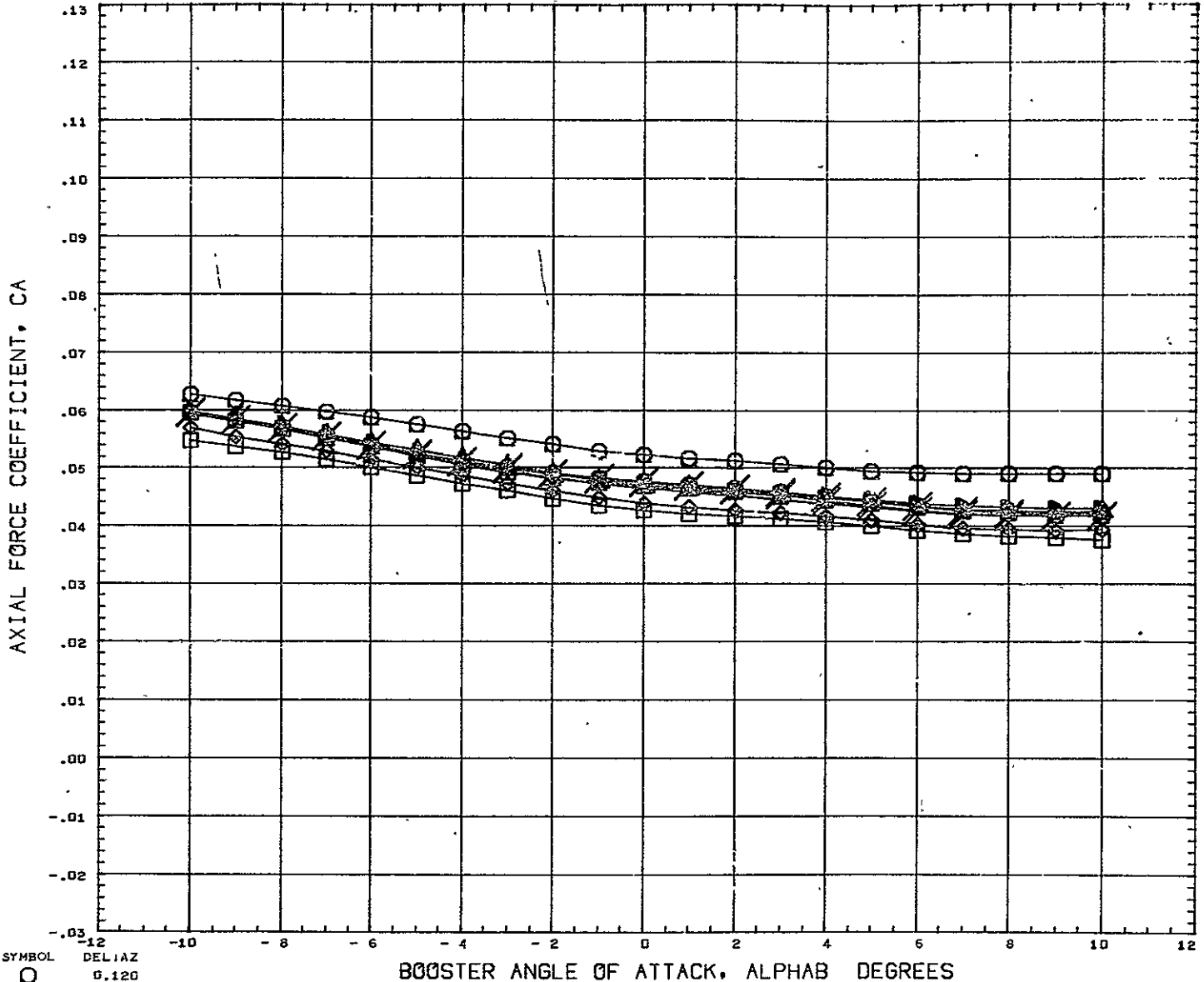

SYMBOL <del>□</del> <del>◇</del> <del>△</del> <del>○</del>	DELIAZ 0.120 0.151 0.182 0.228 0.352 0.599 0.908 10.000	PARAMETRIC VALUES BSTFOW 0.000 ORBPOW 0.000 DELTAX 0.351 ALPHAI 0.000 MACH 5.020 ELVBST 0.000 ELVORB 0.000 BETA 0.000	REFERENCE INFORMATION REFS 23.6890 SQ IN REFL 4.1930 IN REFB 6.5000 IN XMRP 4.9170 IN YMRP 0.0000 IN ZMRP 1.3900 IN SCALE 0.0055
--	---	---	---

# AEDC VA 1163 MDAC BOOSTER AND ORBITER TEST DATA AT MACH NUMBER 5

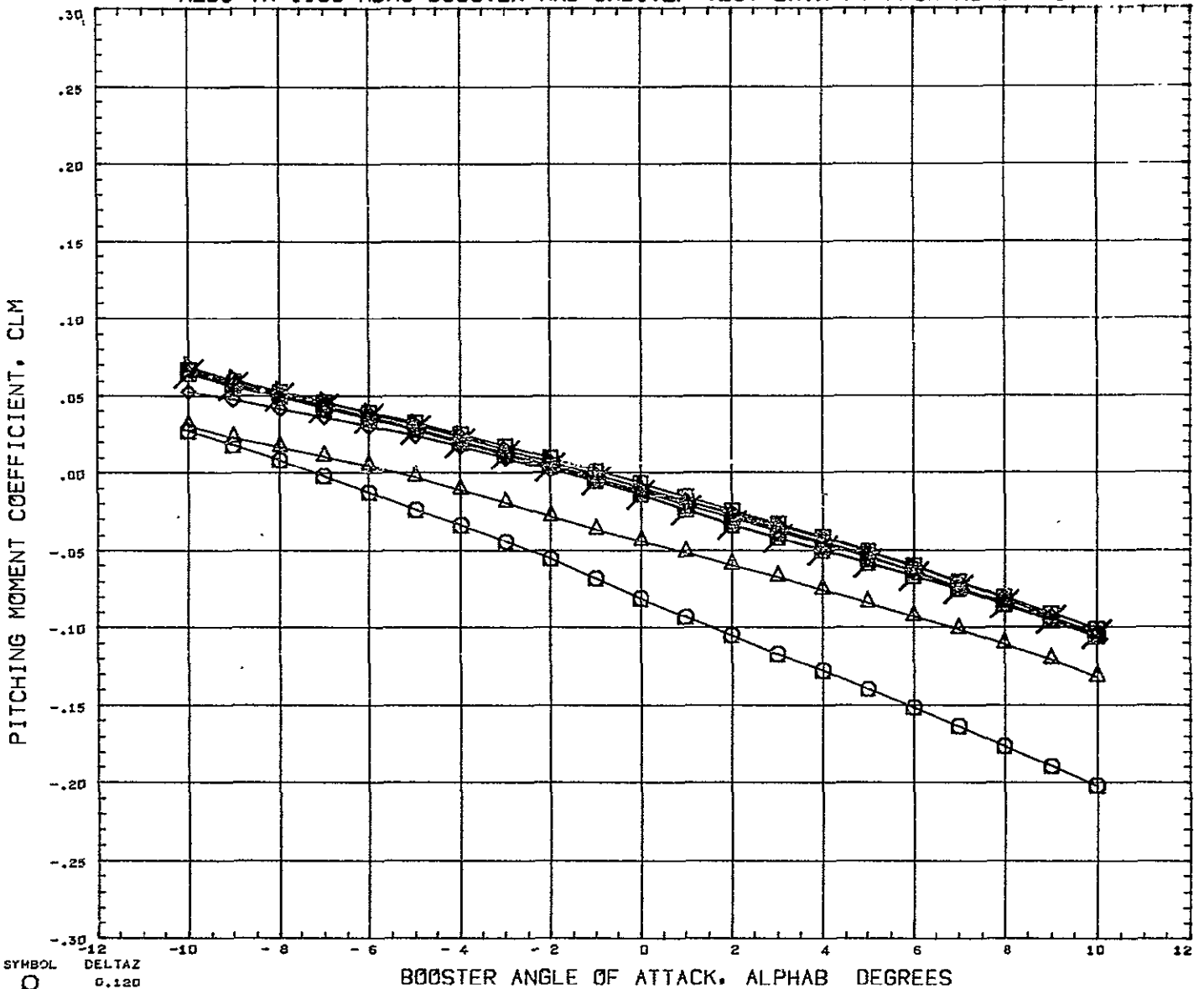

SYMBOL ○ □ △ ○ □ △	DELTAX 0.120 0.151 0.182 0.228 0.332 0.599 0.908 10.000 REFERENCE FILE	PARAMETRIC VALUES BSTPOW 0.000 ORBPOW 0.000 DELTAX 0.522 ALPHA1 0.000 MACH 5.020 ELVOST 0.000 ELVORB 0.000 BETA 0.050	REFERENCE INFORMATION REFS 23.6890 SQ IN REFL 4.1930 IN REFB 6.5000 IN XMRP 4.9170 IN YMRP 0.0000 IN ZMRP 1.3900 IN SCALE 0.0055
--------------------------------------	---	---	---

# AEDC VA 1163 MDAC BOOSTER AND ORBITER TEST DATA AT MACH NUMBER 5

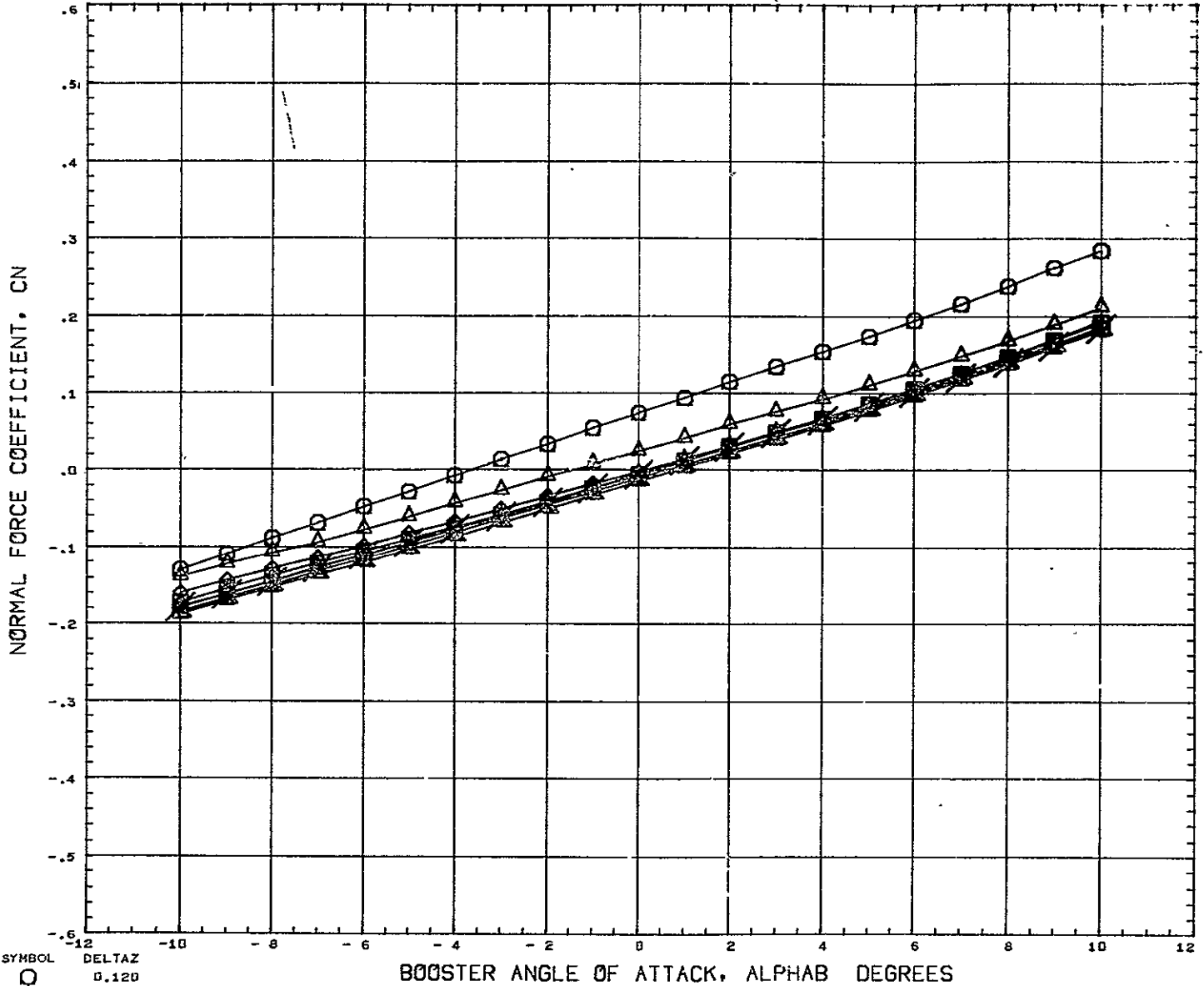

SYMBOL ○ △ □ ◇ ×	DELTAZ 0.120 0.151 0.182 0.228 0.352 0.599 0.958 19.000	PARAMETRIC VALUES BSTFOW 0.000 ORBPOW 0.000 JELTAX 0.522 ALPHAI 0.000 MACH 5.020 ELVBST 0.000 ELVORB 0.000 BETA 0.000 REFERENCE FILE	REFERENCE INFORMATION REFS 23.6890 SQ IN REFL 4.1930 IN REFB 6.5000 IN XMRP 4.9170 IN YMRP 0.0000 IN ZMRP 1.3900 IN SCALE 0.0055
---------------------------------	---	---	---



# AEDC VA 1163 MDAC BOOSTER AND ORBITER TEST DATA AT MACH NUMBER 5

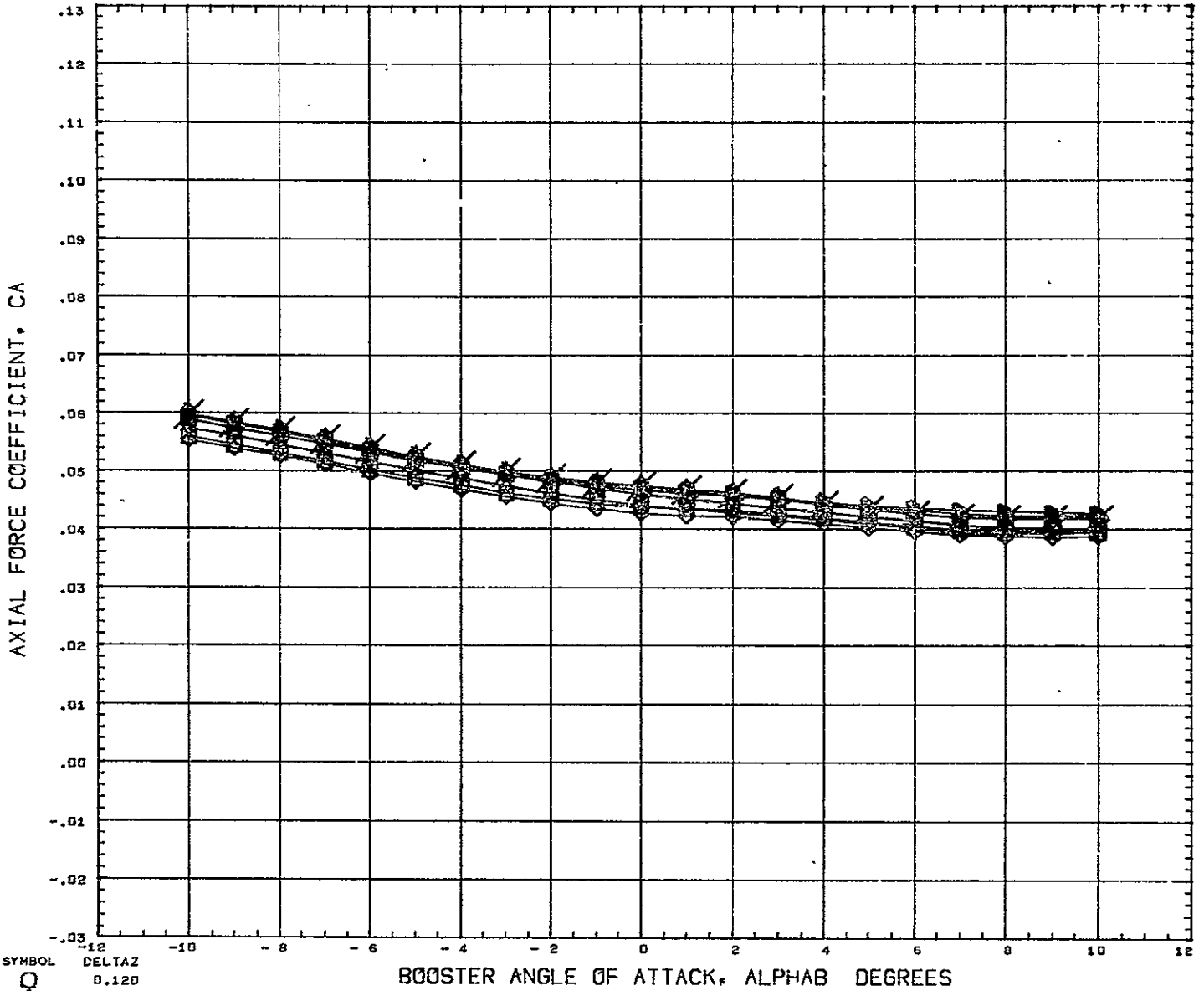

SYMBOL $\diamond$ $\square$ $\triangle$ $\nabla$ $\circ$ $\times$ $\cdot$	DELTAZ 0.120 0.151 0.182 0.228 0.352 0.599 0.908 10.000	PARAMETRIC VALUES BSTFOW 0.000 ORBFOW 0.000 JELTAX 0.522 ALPHAI 0.000 MACH 5.020 ELVBST 0.000 ELVORB 0.000 BETA 0.000	REFERENCE INFORMATION REFS 23.6890 SQ IN REFL 4.1930 IN REFB 6.5000 IN XHRF 4.9170 IN YMRP 0.0000 IN ZMRP 1.3900 IN SCALE 0.0055
--	---	---	---

# AEDC VA 1163 MDAC BOOSTER AND ORBITER TEST DATA AT MACH NUMBER 5

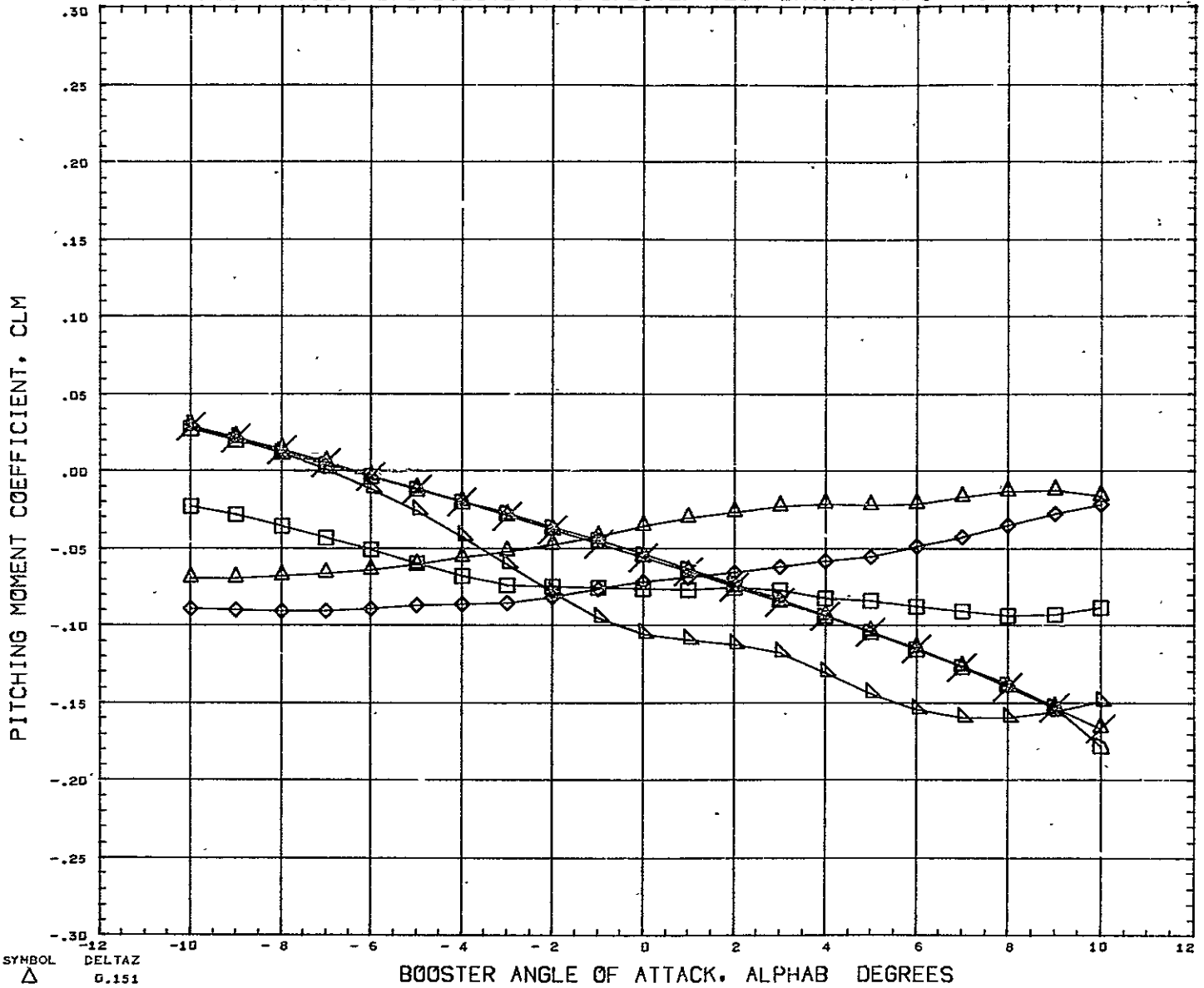

SYMBOL △ ◇ □ ▽ ×	DELTA Z 0.151 0.182 0.228 0.352 0.599 10.000	<b>PARAMETRIC VALUES</b> BSTPOW    0.000    ORBPOW    0.000 JELTAX    - 0.390    ALPHA1    5.100 MACH       5.010    ELVBST    0.000 ELVORB    0.000    BETA       0.000	<b>REFERENCE INFORMATION</b> REFS       23.6890    SQ IN REFL       4.1930    IN REFB       6.5000    IN XMRP       4.9170    IN YMRP       0.0000    IN ZMRP       1.3900    IN SCALE       0.0055
REFERENCE FILE			

# AEDC VA 1163 MDAC BOOSTER AND ORBITER TEST DATA AT MACH NUMBER 5

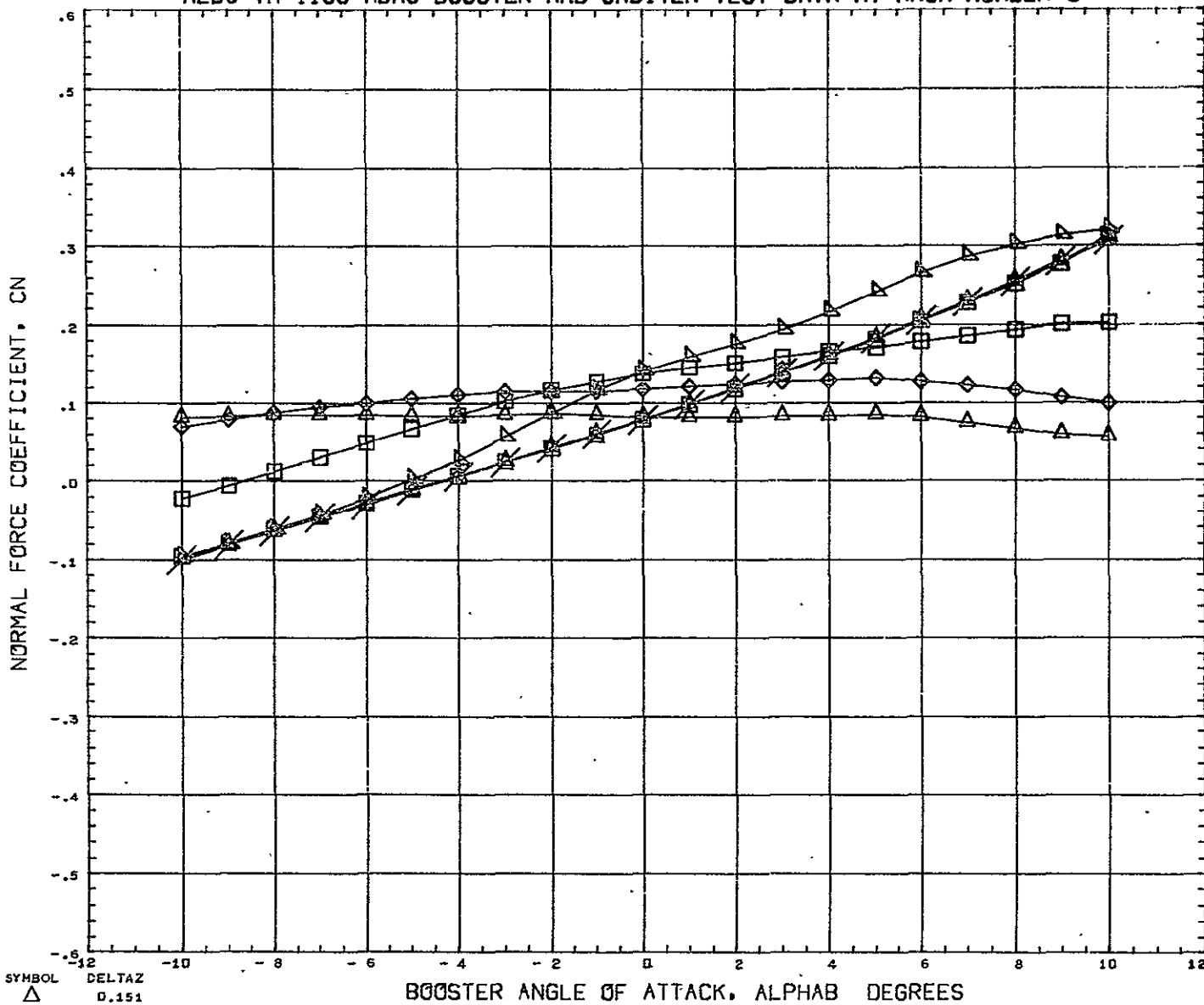

SYMBOL △ ◇ □ ×	DELTAZ 0.151 0.102 0.228 0.352 0.599 10.000	PARAMETRIC VALUES PSTPOW    0.000    ORBPOW    0.000 DELTAX    - 0.390    ALPHAI    5.100 MACH       5.010    ELVBST    0.000 ELVORB    0.000    BETA       0.000	REFERENCE INFORMATION REFS       23.6890    SQ IN REFL       4.1930    IN REFB       6.5000    IN XMRF       4.9170    IN YMRF       0.0000    IN ZMRF       1.3900    IN SCALE      0.0055
----------------------------	---	---	--

REFERENCE FILE

# AEDC VA 1163 MDAC BOOSTER AND ORBITER TEST DATA AT MACH NUMBER 5

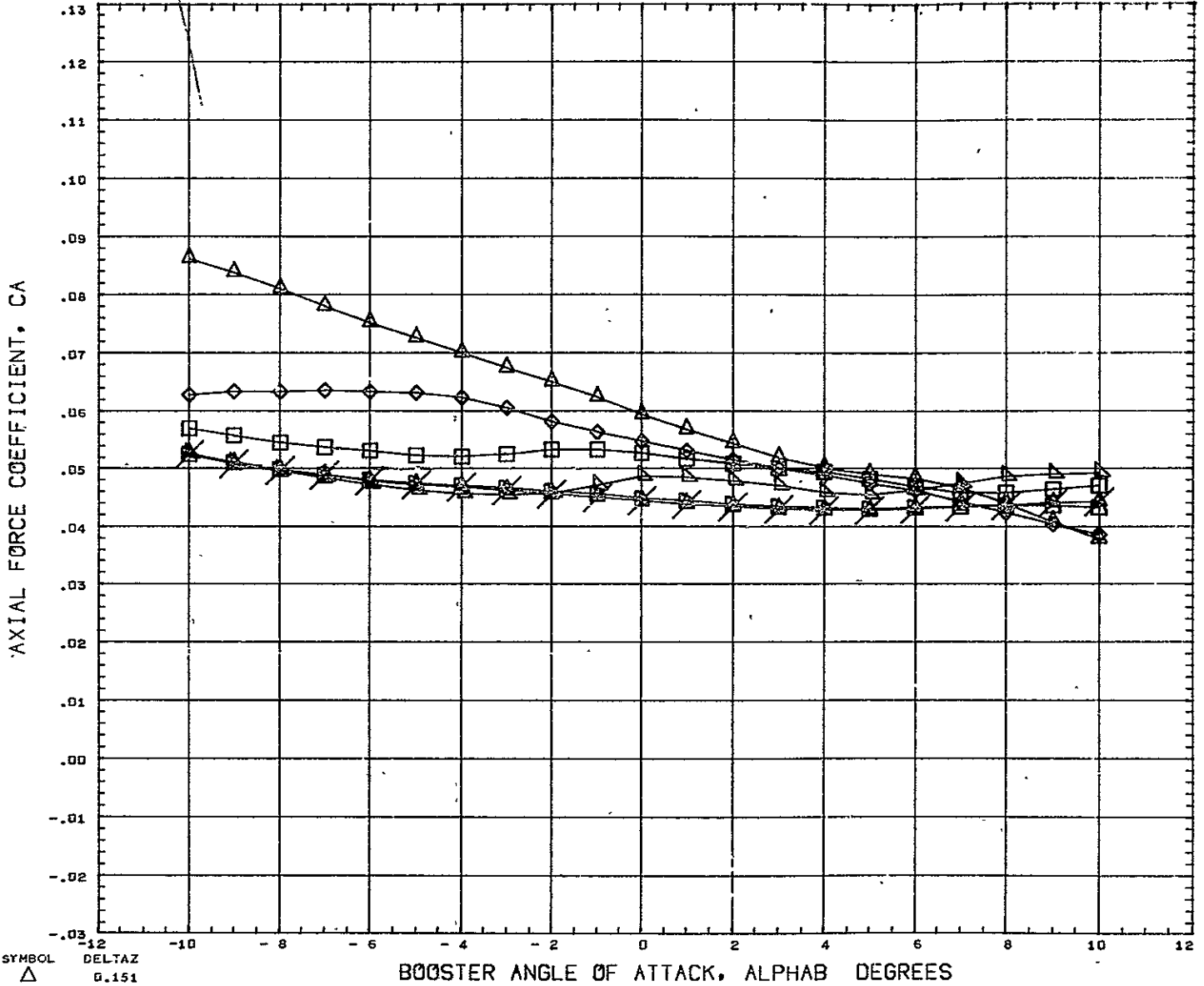

SYMBOL △ ◇ □ ⊗	DELTAZ 0.151 0.182 0.228 0.352 0.599 10.000	<b>PARAMETRIC VALUES</b> BSTPOW    0.000    ORBPOW    0.000 LELTAX    - 0.390    ALPHAI    5.100 MACH       5.010    ELVBST    0.000 ELVORB    0.000    BETA       0.000	<b>REFERENCE INFORMATION</b> REFS       23.6890    SQ IN REFL       4.1930    IN REFB       6.5000    IN XMRP       4.9170    IN YMRP       0.0000    IN ZMRP       1.3900    IN SCALE      0.0055
----------------------------	---	--	---

REFERENCE FILE

# AEDC VA 1163 MDAC BOOSTER AND ORBITER TEST DATA AT MACH NUMBER 5

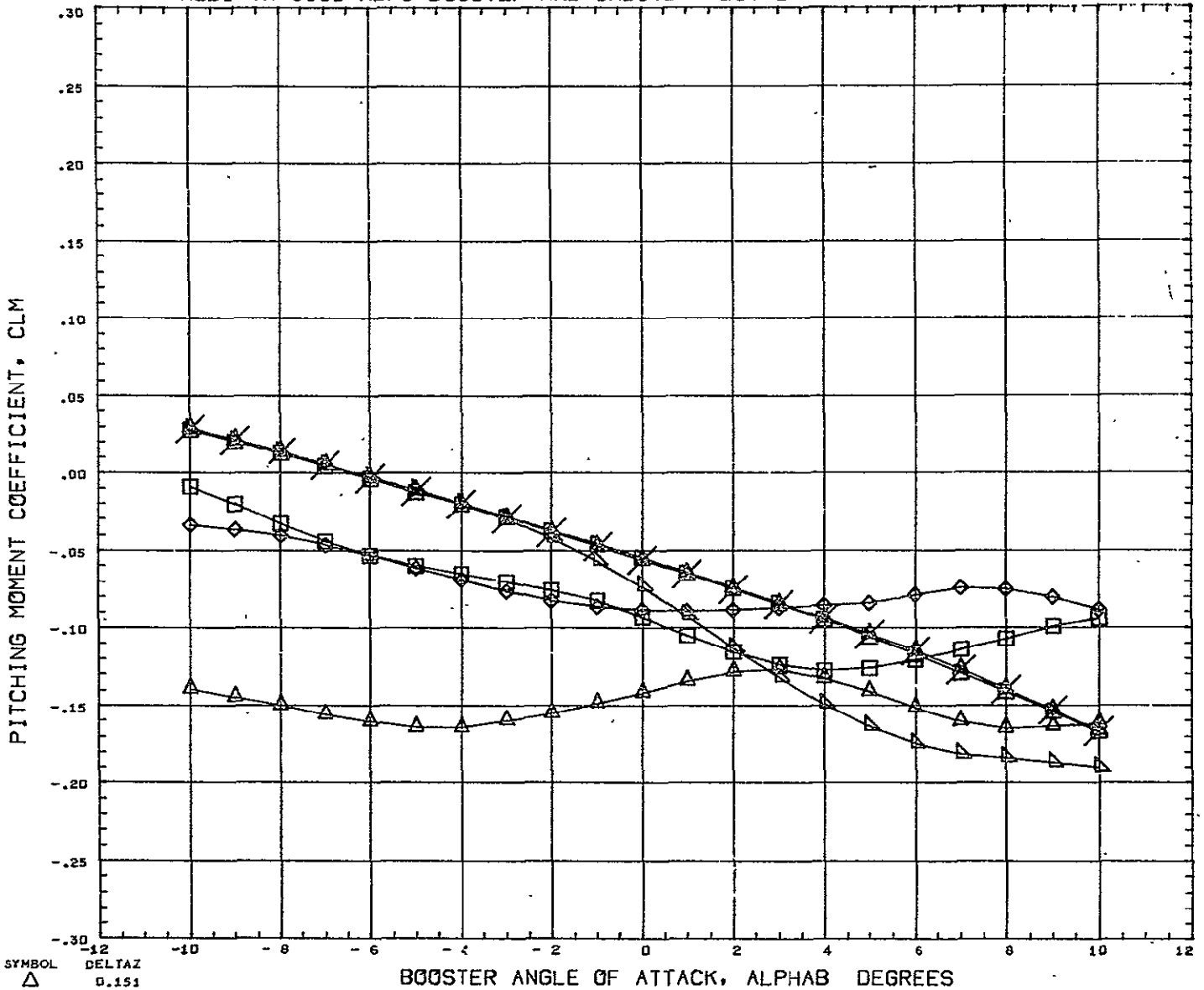

SYMBOL △ ◇ □ × ▽	DELTAZ 0.151 0.182 0.228 0.352 0.599 10.000	PARAMETRIC VALUES P5TFOW 0.000 ORBFOW 0.000 DELTAX - 0.143 ALPHAI 5.100 MACH 5.010 ELVBST 0.000 ELVORB 0.000 BETA 0.000	REFERENCE INFORMATION REFS 23.6890 SQ IN REFL 4.1930 IN REFB 6.5000 IN XMRP 4.9170 IN YMRP 0.0000 IN ZMRP 1.3900 IN SCALE 0.0055
REFERENCE FILE			

# AEDC VA 1163 MDAC BOOSTER AND ORBITER TEST DATA AT MACH NUMBER 5

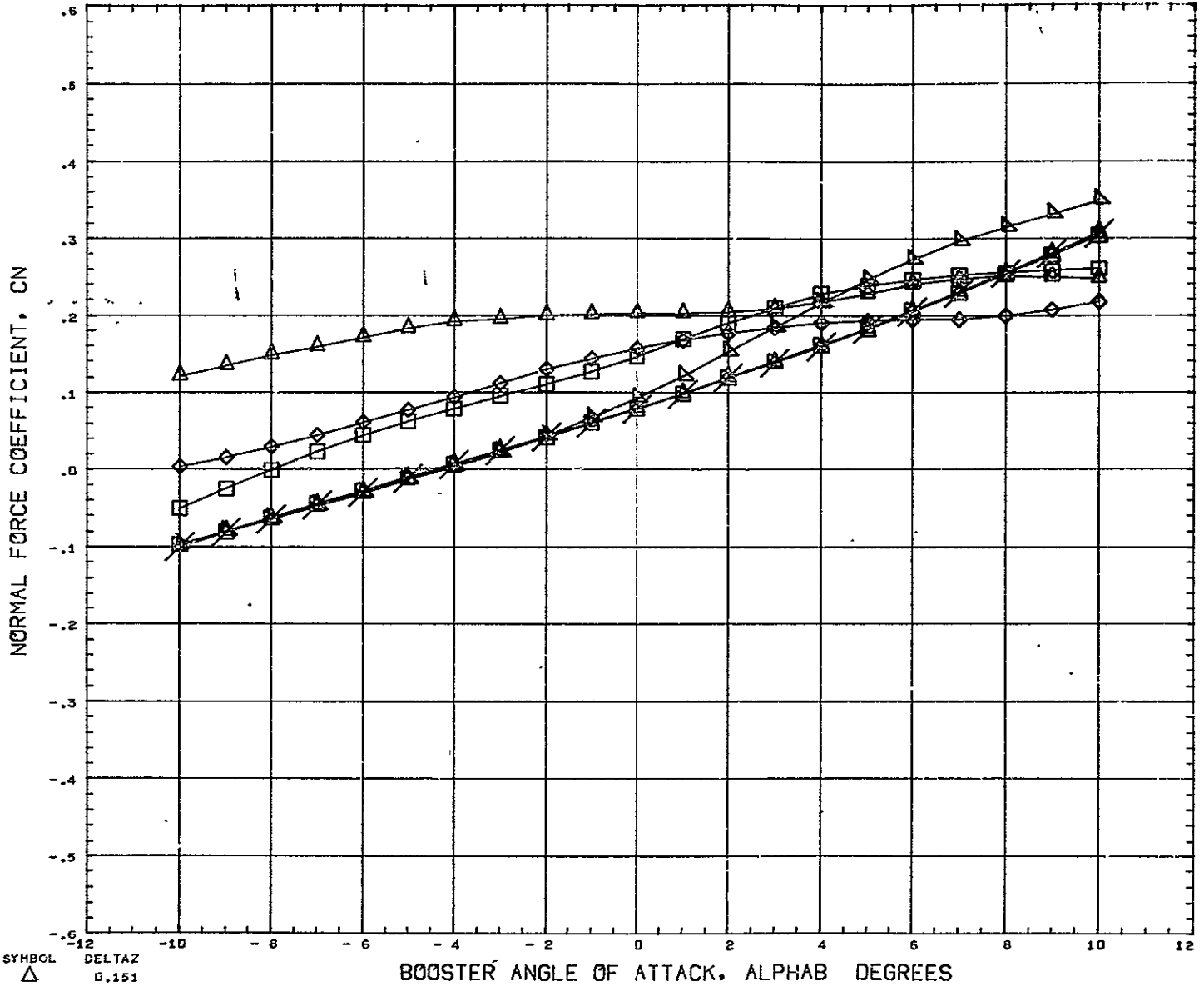

SYMBOL 	DELTAZ 0.151 0.182 0.228 0.352 0.599 10.000	PARAMETRIC VALUES BSTPOW 0.000 ORBPOW 0.000 ELTAX - 0.143 ALFHAI 5.100 MACH 5.010 ELVBST 0.000 ELVORB 0.000 BETA 0.000	REFERENCE INFORMATION REFS 23.6890 SQ IN REFL 4.1930 IN REFB 6.5000 IN XMRP 4.9170 IN YMRP 0.0000 IN ZMRP 1.3900 IN SCALE 0.0055
------------	---	--	---

REFERENCE FILE

# AEDC VA 1163 MDAC BOOSTER AND ORBITER TEST DATA AT MACH NUMBER 5

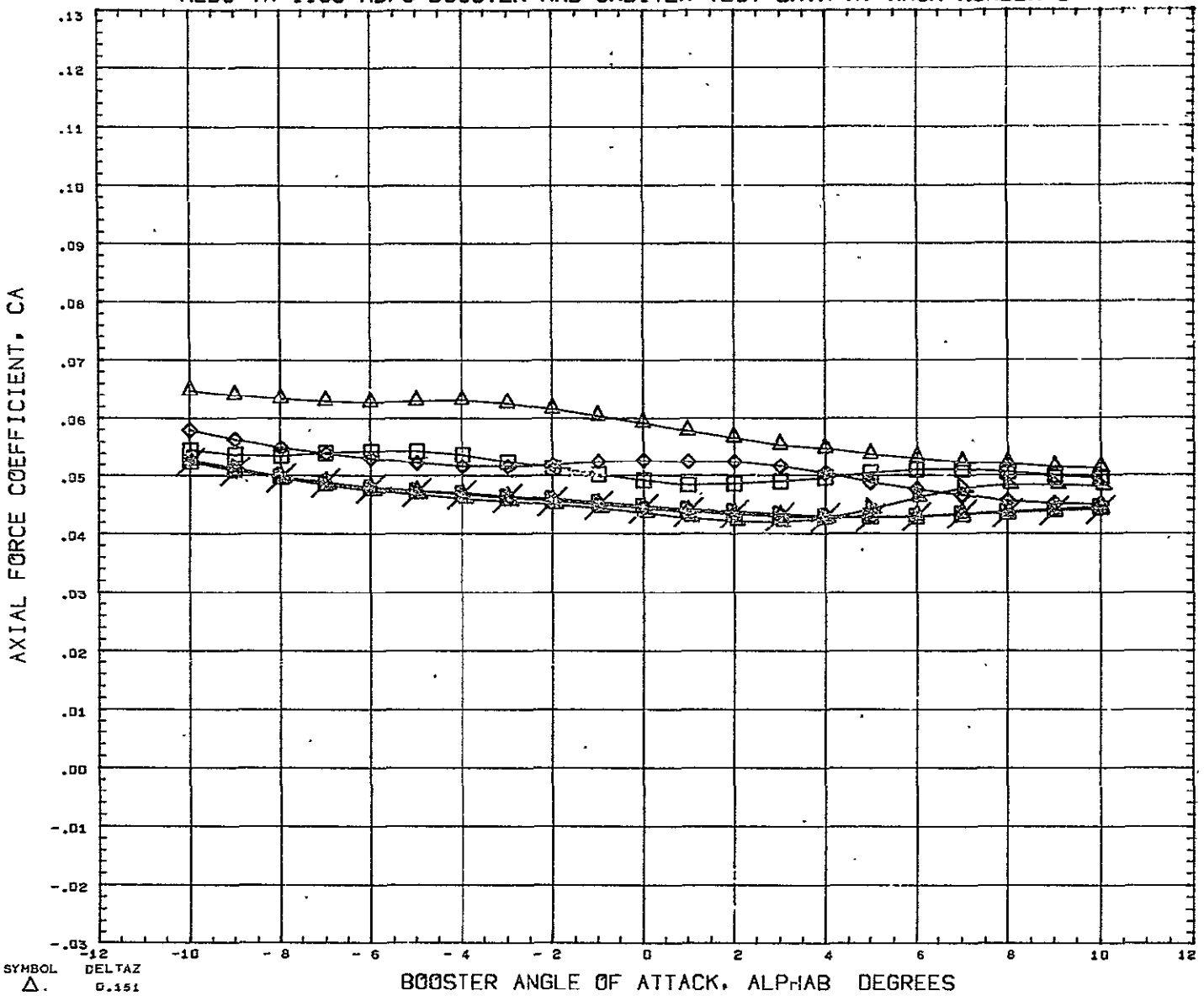

SYMBOL △ ◇ □ ○ ×	DELTA Z 0.151 0.182 0.228 0.352 0.599 10.000	PARAMETRIC VALUES BSTFOW 0.000 CRBPOW 0.000 I_LTAX - 0.143 ALPHAI 5.100 MACH 5.010 ELVBST 0.000 ELVORB 0.000 BETA 0.000	REFERENCE INFORMATION REFS 23.6890 SQ IN REFL 4.1930 IN REFB 6.5000 IN XMRP 4.9170 IN YMRP 0.0000 IN ZMRP 1.3900 IN SCALE 0.0055
---------------------------------	--	---	---

REFERENCE FILE

# AEDC VA 1163 MDAC BOOSTER AND ORBITER TEST DATA AT MACH NUMBER 5

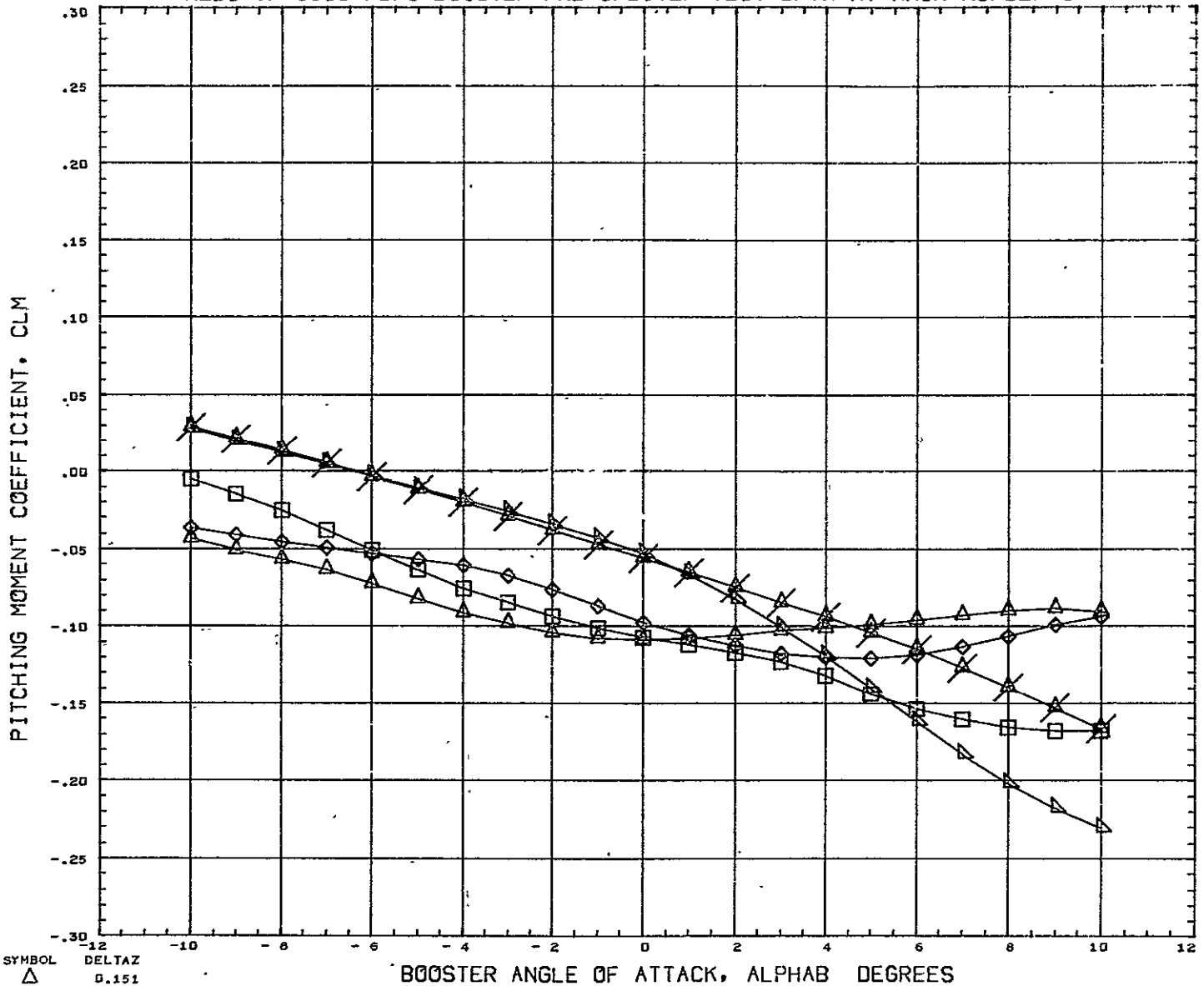

SYMBOL △ □ ◇ ▽ ×	DELTA Z 0.151 0.182 0.228 0.352 10.000	PARAMETRIC VALUES BSTPOW    0.000    ORBPOW    0.000 DELTAX    - 0.019    ALPHA1    5.100 MACH       5.010    ELVBST    0.000 ELVORB    0.000    BETA       0.000	REFERENCE INFORMATION REFS       23.6890    SQ IN REFL       4.1930    IN REFB       6.5000    IN XMRP       4.9170    IN YMRP       0.0006    IN ZMRP       1.3900    IN SCALE       0.0055
---------------------------------	---	---	---

REFERENCE FILE



# AEDC VA 1163 MDAC BOOSTER AND ORBITER TEST DATA AT MACH NUMBER 5

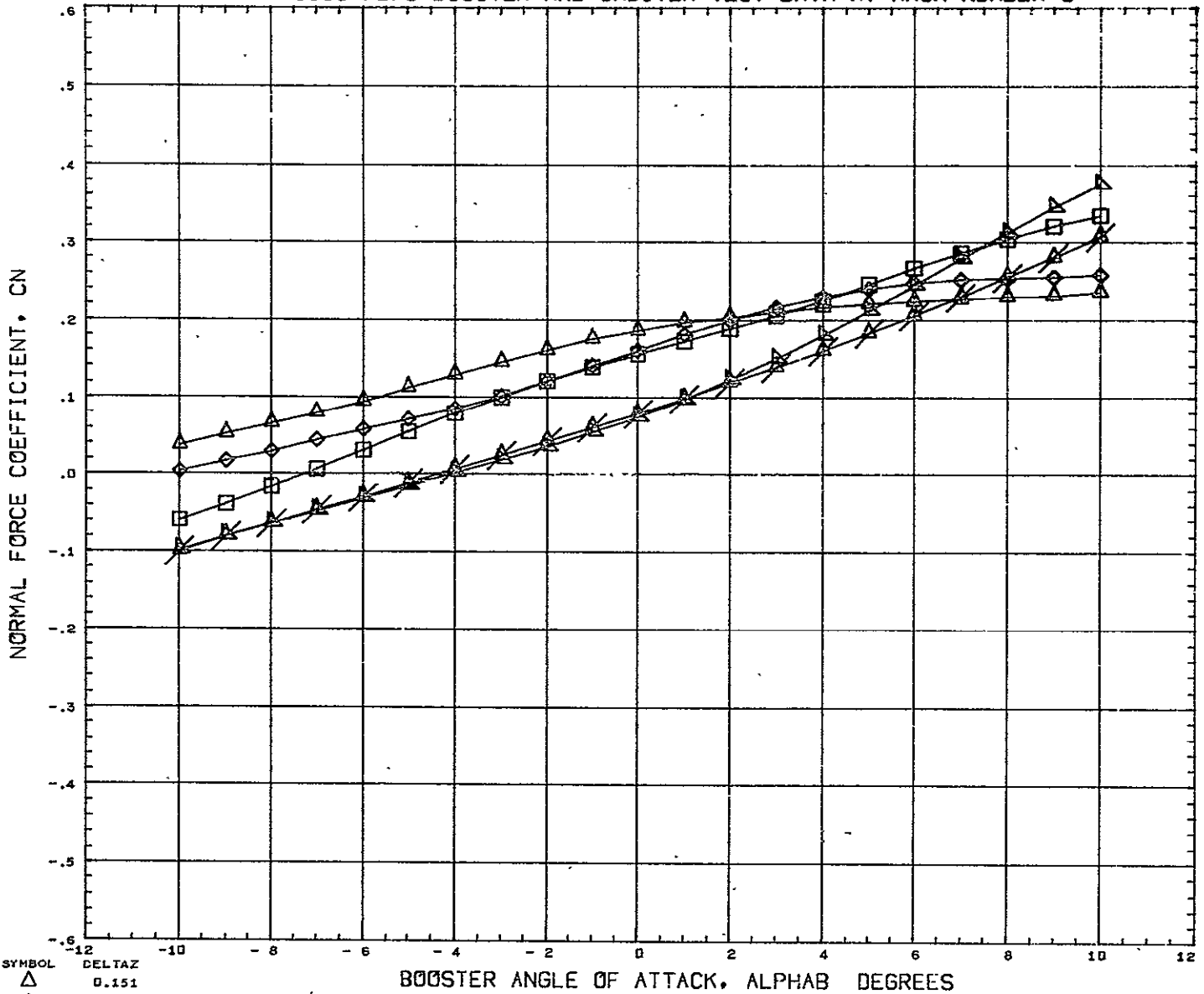

SYMBOL △ ◇ □ ○ ×	DELTA Z 0.151 0.182 0.228 0.352 10.000	PARAMETRIC VALUES BSTFOW 0.000 CRBPOW 0.000 DF TAX - 0.019 ALPHAI 5.100 MACH 5.010 ELVBST 0.000 ELVORB 0.000 BETA 0.000	REFERENCE INFORMATION REFS 23.6890 SQ IN REFL 4.1930 IN REFB 6.5000 IN XMRF 4.9170 IN YMRP 0.0000 IN ZMRP 1.3900 IN SCALE 0.0055
REFERENCE FILE			

# AEDC VA 1163 MDAC BOOSTER AND ORBITER TEST DATA AT MACH NUMBER 5

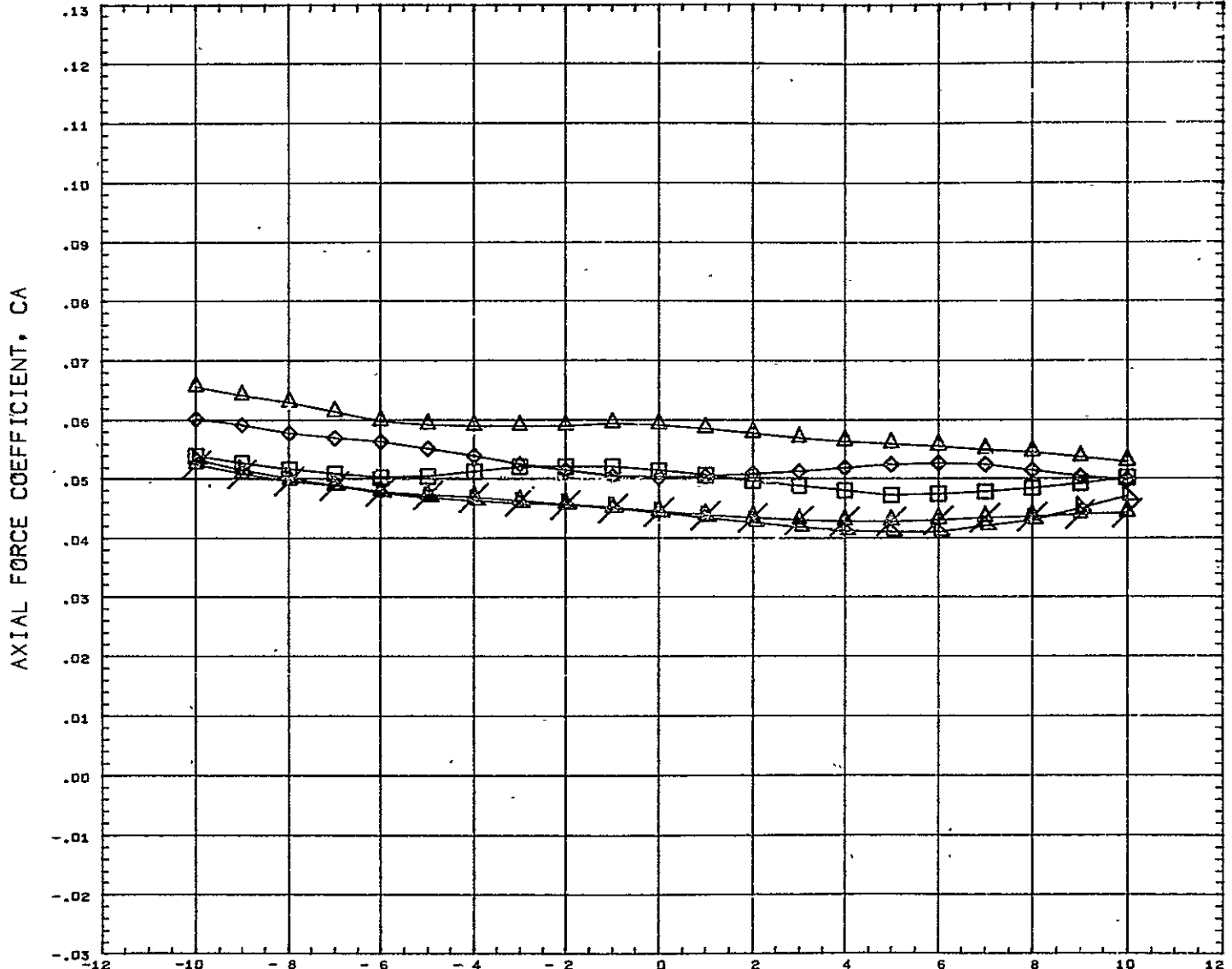

SYMBOL △ ◇ □ ×	DELTAZ 0.151 0.182 0.228 0.352 10.000	PARAMETRIC VALUES BSTFOW    0.000    ORBPOW    0.000 DELTAX    0.019    ALPHAI    5.100 MACH       5.010    ELVBST    -0.000 ELVORB    0.000    BETA       0.000	REFERENCE INFORMATION REFS       23.6890    SQ IN REFL       4.1930    IN REFB       6.5000    IN XMRP       4.9170    IN YMRP       0.0000    IN ZMRP       1.3900    IN SCALE       0.0055
----------------------------	--	--	---

REFERENCE FILE

# AEDC VA 1163 MDAC BOOSTER AND ORBITER TEST DATA AT MACH NUMBER 5

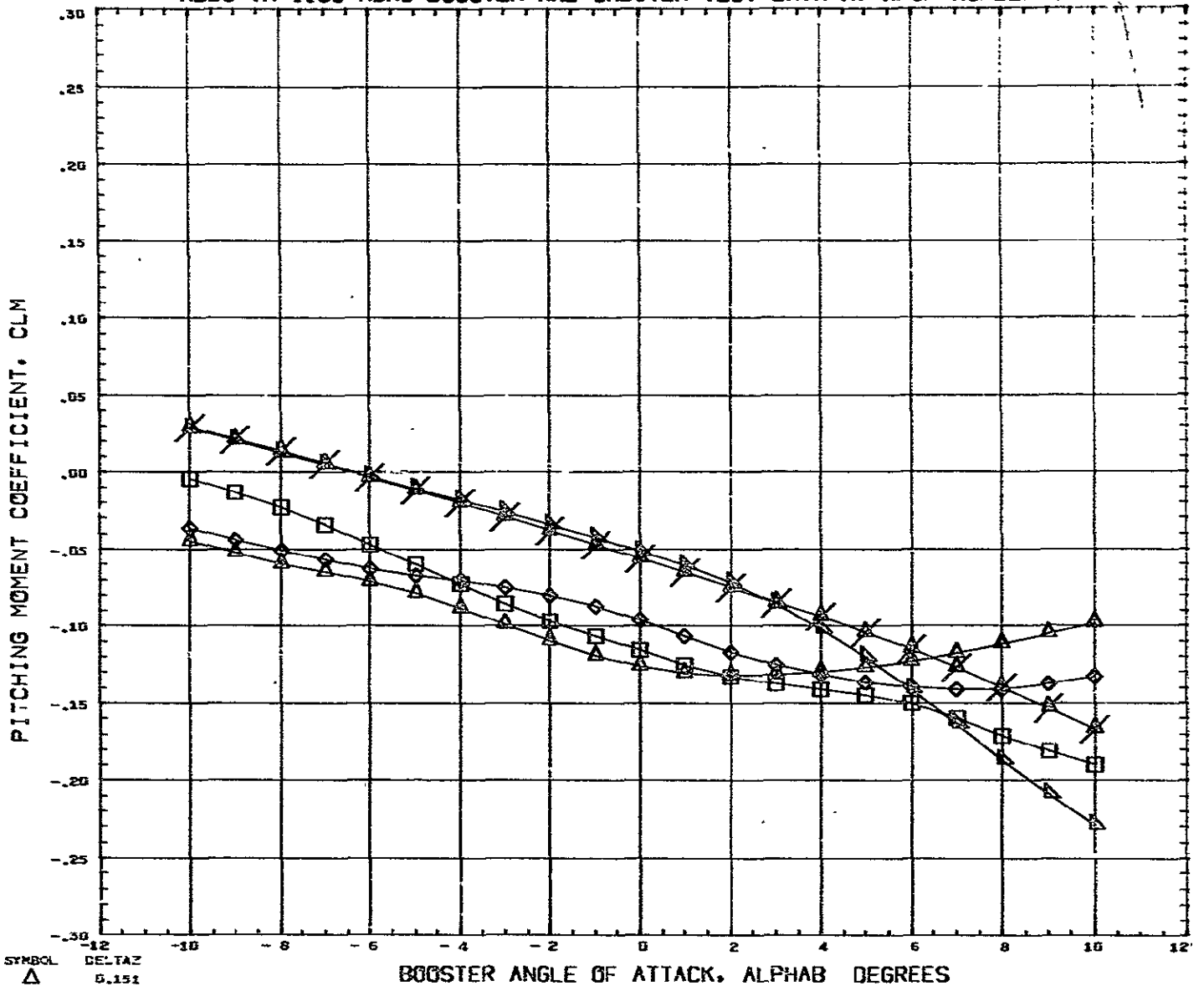

<p>SYMBOL</p> <p>△</p> <p>◇</p> <p>□</p> <p>▽</p> <p>×</p>	<p>DELTA Z</p> <p>0.151</p> <p>0.162</p> <p>0.228</p> <p>0.352</p> <p>10.000</p>	<p>PARAMETRIC VALUES</p> <table border="0"> <tr> <td>BSTFOW</td><td>0.000</td><td>ORBFOW</td><td>0.000</td></tr> <tr> <td>CELTAX</td><td>0.043</td><td>ALPHA1</td><td>5.150</td></tr> <tr> <td>MACH</td><td>5.010</td><td>ELVBST</td><td>0.000</td></tr> <tr> <td>ELVORB</td><td>0.000</td><td>BETA</td><td>0.000</td></tr> </table>	BSTFOW	0.000	ORBFOW	0.000	CELTAX	0.043	ALPHA1	5.150	MACH	5.010	ELVBST	0.000	ELVORB	0.000	BETA	0.000	<p>REFERENCE INFORMATION</p> <table border="0"> <tr> <td>REFS</td><td>23.6600</td><td>SQ IN.</td></tr> <tr> <td>REFL</td><td>4.1930</td><td>IN.</td></tr> <tr> <td>REFS</td><td>6.5000</td><td>IN.</td></tr> <tr> <td>XMRP</td><td>4.9370</td><td>IN.</td></tr> <tr> <td>YMRP</td><td>0.0000</td><td>IN.</td></tr> <tr> <td>ZMRP</td><td>1.3900</td><td>IN.</td></tr> <tr> <td>SCALE</td><td>0.0000</td><td></td></tr> </table>	REFS	23.6600	SQ IN.	REFL	4.1930	IN.	REFS	6.5000	IN.	XMRP	4.9370	IN.	YMRP	0.0000	IN.	ZMRP	1.3900	IN.	SCALE	0.0000	
BSTFOW	0.000	ORBFOW	0.000																																					
CELTAX	0.043	ALPHA1	5.150																																					
MACH	5.010	ELVBST	0.000																																					
ELVORB	0.000	BETA	0.000																																					
REFS	23.6600	SQ IN.																																						
REFL	4.1930	IN.																																						
REFS	6.5000	IN.																																						
XMRP	4.9370	IN.																																						
YMRP	0.0000	IN.																																						
ZMRP	1.3900	IN.																																						
SCALE	0.0000																																							

REFERENCE FILE

# AEDC VA 1163 MDAC BOOSTER AND ORBITER TEST DATA AT MACH NUMBER 5

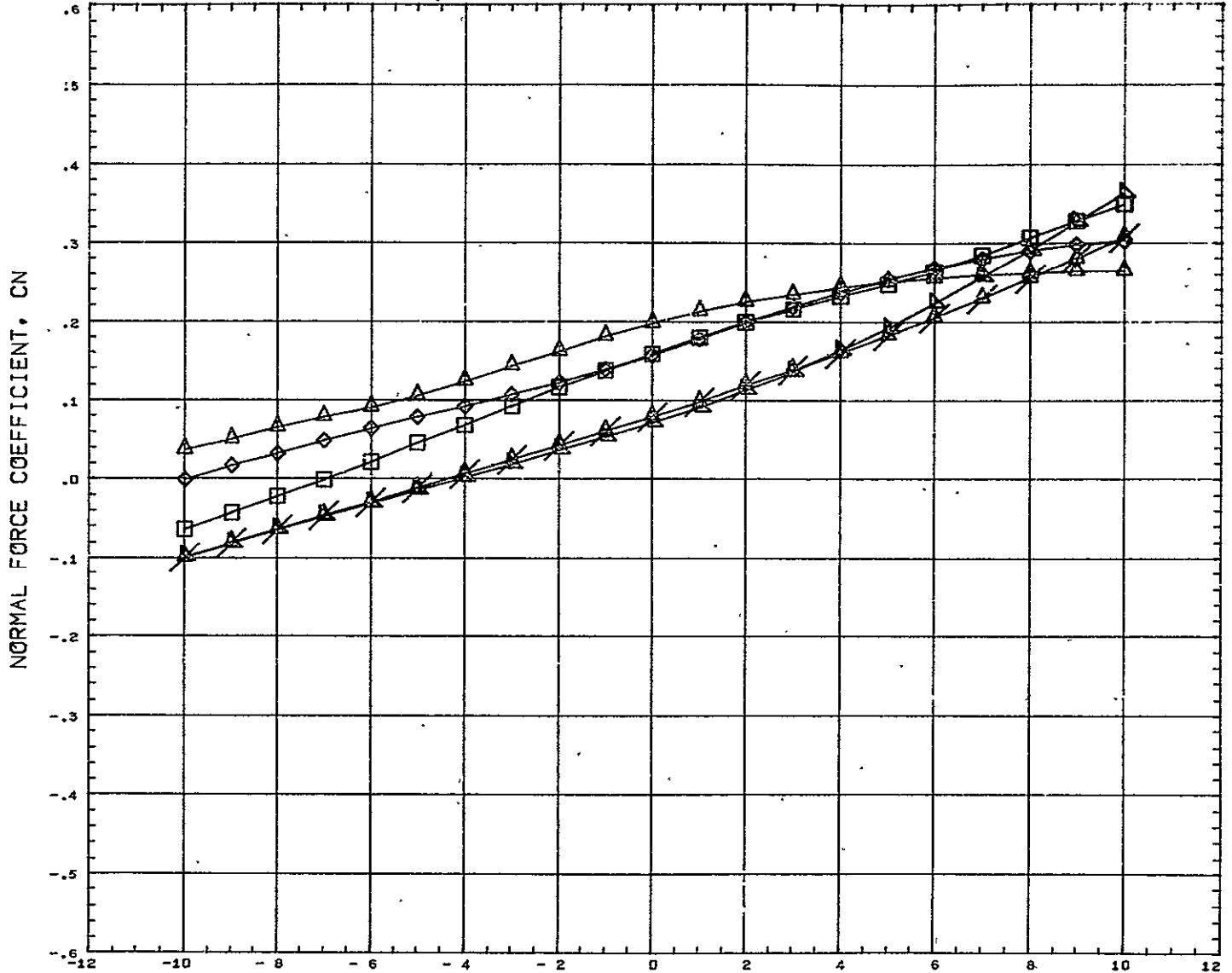

SYMBOL △ ◇ □ ○ ×	DELTA Z 0.151 0.182 0.228 0.352 10.000	<table border="0" style="width: 100%;"> <tr> <th colspan="4" style="text-align: left;">PARAMETRIC VALUES</th> </tr> <tr> <td>BSTPOW</td><td>0.000</td><td>ORBPOW</td><td>0.000</td> </tr> <tr> <td>DELTA X</td><td>0.043</td><td>ALPHA I</td><td>5.160</td> </tr> <tr> <td>MACH</td><td>5.010</td><td>ELVBST</td><td>0.000</td> </tr> <tr> <td>ELVORB</td><td>0.000</td><td>BETA</td><td>0.000</td> </tr> </table>	PARAMETRIC VALUES				BSTPOW	0.000	ORBPOW	0.000	DELTA X	0.043	ALPHA I	5.160	MACH	5.010	ELVBST	0.000	ELVORB	0.000	BETA	0.000	<table border="0" style="width: 100%;"> <tr> <th colspan="3" style="text-align: left;">REFERENCE INFORMATION</th> </tr> <tr> <td>REFS</td><td>23.6890</td><td>SQ IN</td> </tr> <tr> <td>REFL</td><td>4.1930</td><td>IN</td> </tr> <tr> <td>REFB</td><td>6.5000</td><td>IN</td> </tr> <tr> <td>XMRP</td><td>4.9170</td><td>IN</td> </tr> <tr> <td>YMRP</td><td>0.0000</td><td>IN</td> </tr> <tr> <td>ZMRP</td><td>1.3900</td><td>IN</td> </tr> <tr> <td>SCALE</td><td>0.0055</td><td></td> </tr> </table>	REFERENCE INFORMATION			REFS	23.6890	SQ IN	REFL	4.1930	IN	REFB	6.5000	IN	XMRP	4.9170	IN	YMRP	0.0000	IN	ZMRP	1.3900	IN	SCALE	0.0055	
PARAMETRIC VALUES																																															
BSTPOW	0.000	ORBPOW	0.000																																												
DELTA X	0.043	ALPHA I	5.160																																												
MACH	5.010	ELVBST	0.000																																												
ELVORB	0.000	BETA	0.000																																												
REFERENCE INFORMATION																																															
REFS	23.6890	SQ IN																																													
REFL	4.1930	IN																																													
REFB	6.5000	IN																																													
XMRP	4.9170	IN																																													
YMRP	0.0000	IN																																													
ZMRP	1.3900	IN																																													
SCALE	0.0055																																														

REFERENCE FILE

# AEDC VA 1163 MDAC BOOSTER AND ORBITER TEST DATA AT MACH NUMBER 5

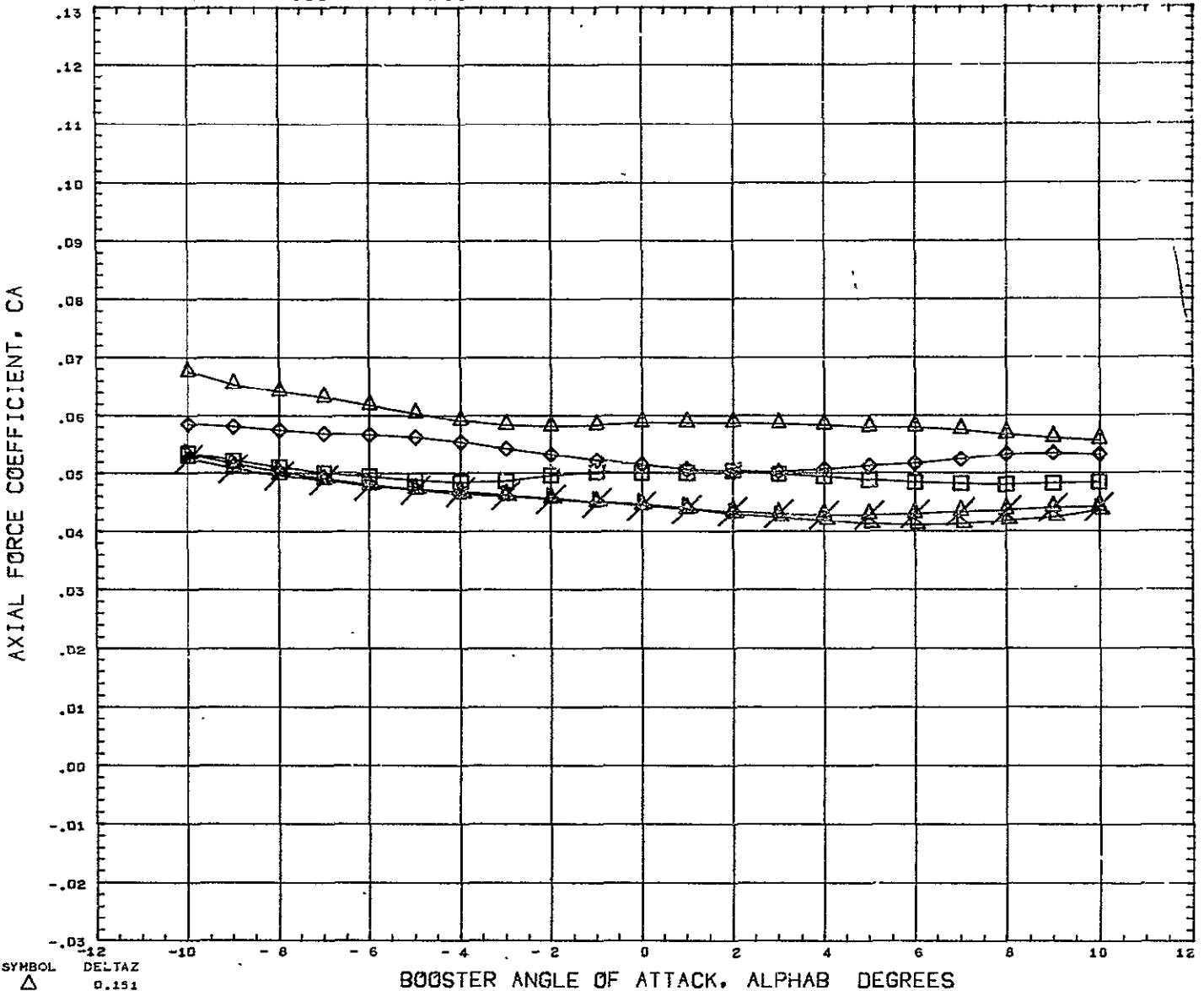

SYMBOL △ ◇ □ ○ ×	DELTAX 0.151 0.182 0.228 0.352 10.000	PARAMETRIC VALUES BSTFOW 0.000 ORBFOW 0.000 DELTAX 0.043 ALPHAI 5.100 MACH 5.010 ELVBST 0.000 ELVORB 0.000 BETA 0.000	REFERENCE INFORMATION REFS 23.6890 SQ IN REFL 4.1930 IN REFB 6.5000 IN XMRP 4.9170 IN YMRP 0.0000 IN ZMRP 1.3900 IN SCALE 0.0055
---------------------------------	--	---	---

REFERENCE FILE

# AEDC VA 1163 MDAC BOOSTER AND ORBITER TEST DATA AT MACH NUMBER 5

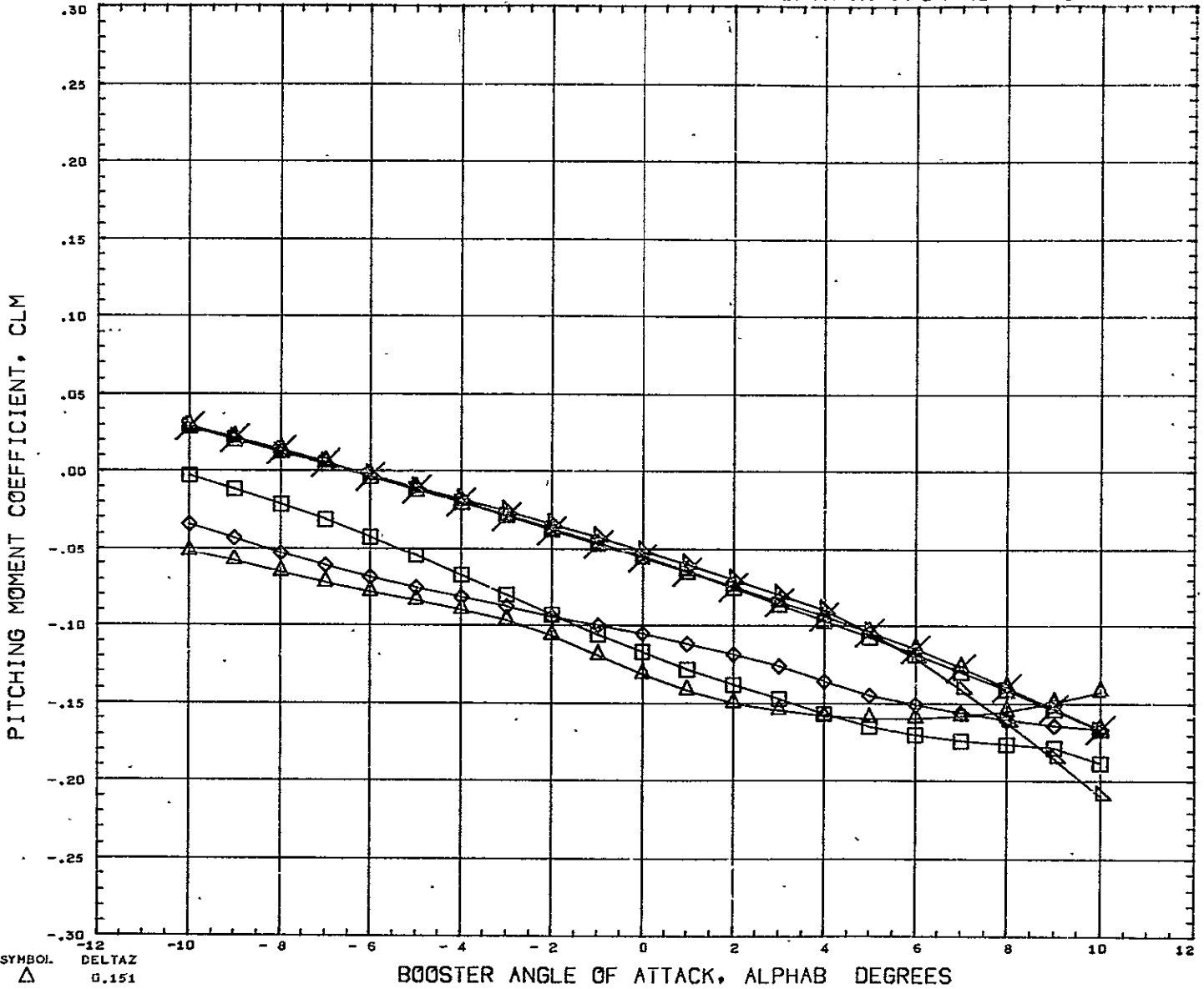

SYMBOL △ ◇ □ ▽ ×	DELTA Z 0.151 0.182 0.228 0.352 0.599 10.000	PARAMETRIC VALUES BSTPOW 0.000 ORBPOW 0.000 JELTAX 0.105 ALPHA1 5.100 MACH 5.010 ELVBST 0.000 ELVORB 0.000 BETA 0.000	REFERENCE INFORMATION REFS 23.6890 SQ IN REFL 4.1930 IN REFB 6.5000 IN XMRP 4.9170 IN YMRP 0.0000 IN ZMRP 1.3900 IN SCALE 0.0055
REFERENCE FILE			

AEDC VA 1163 MDAC BOOSTER AND ORBITER TEST DATA AT MACH NUMBER 5

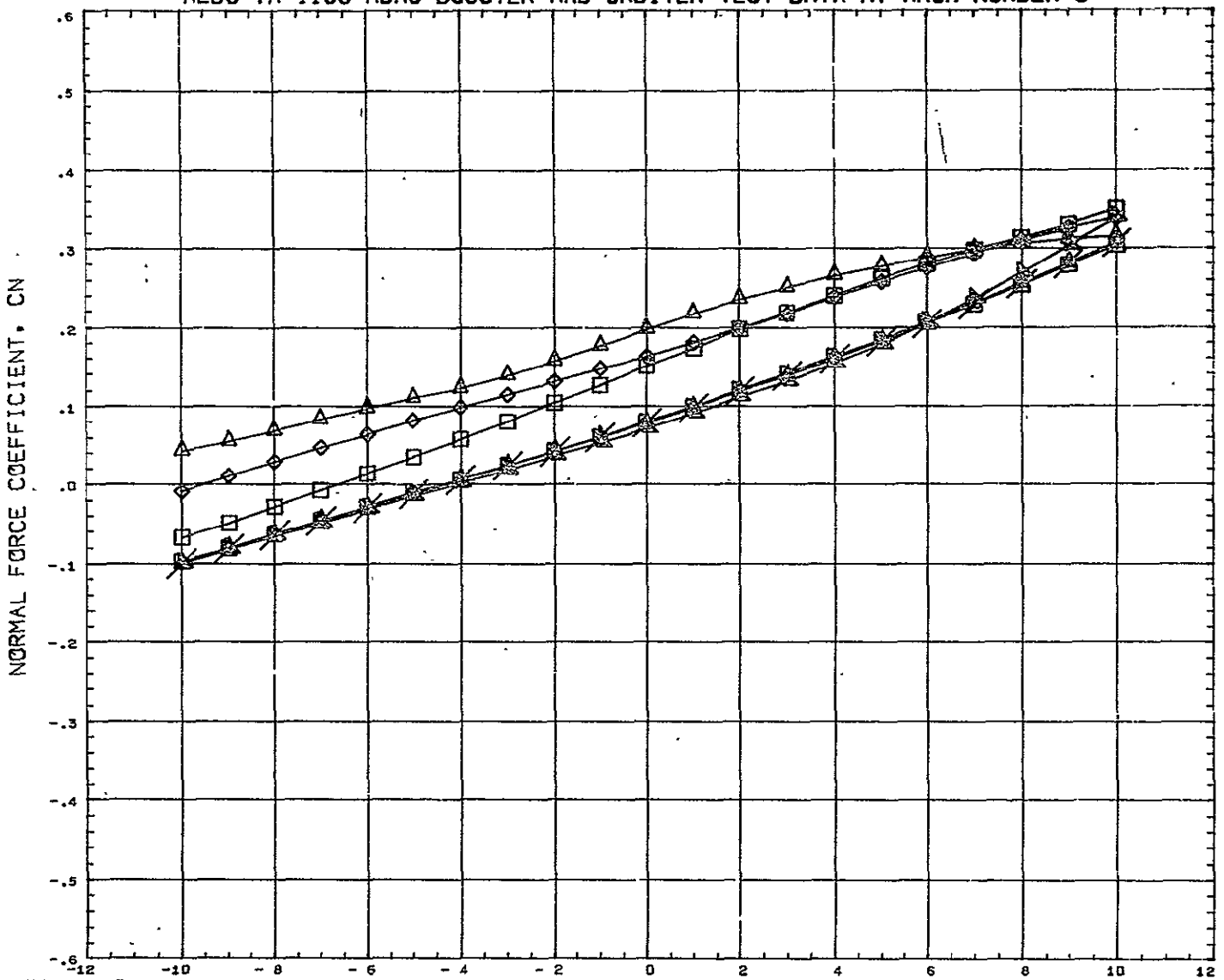

SYMBOL	DELTAZ	PARAMETRIC VALUES				REFERENCE INFORMATION		
△	0.151	BSTPOW	0.000	ORBPOW	0.000	REFS	23.6890	SQ IN
◇	0.182	JELTAX	0.105	ALPHA1	5.100	REFL	4.1930	IN
□	0.226	MACH	5.010	ELVBST	0.000	REFB	6.5000	IN
○	0.352	ELVORB	0.000	BETA	0.000	XMRP	4.9170	IN
×	0.599					YMRP	0.0000	IN
	10.000					ZMRP	1.3900	IN
						SCALE	0.0055	

REFERENCE FILE

# AEDC VA 1163 MDAC BOOSTER AND ORBITER TEST DATA AT MACH NUMBER 5

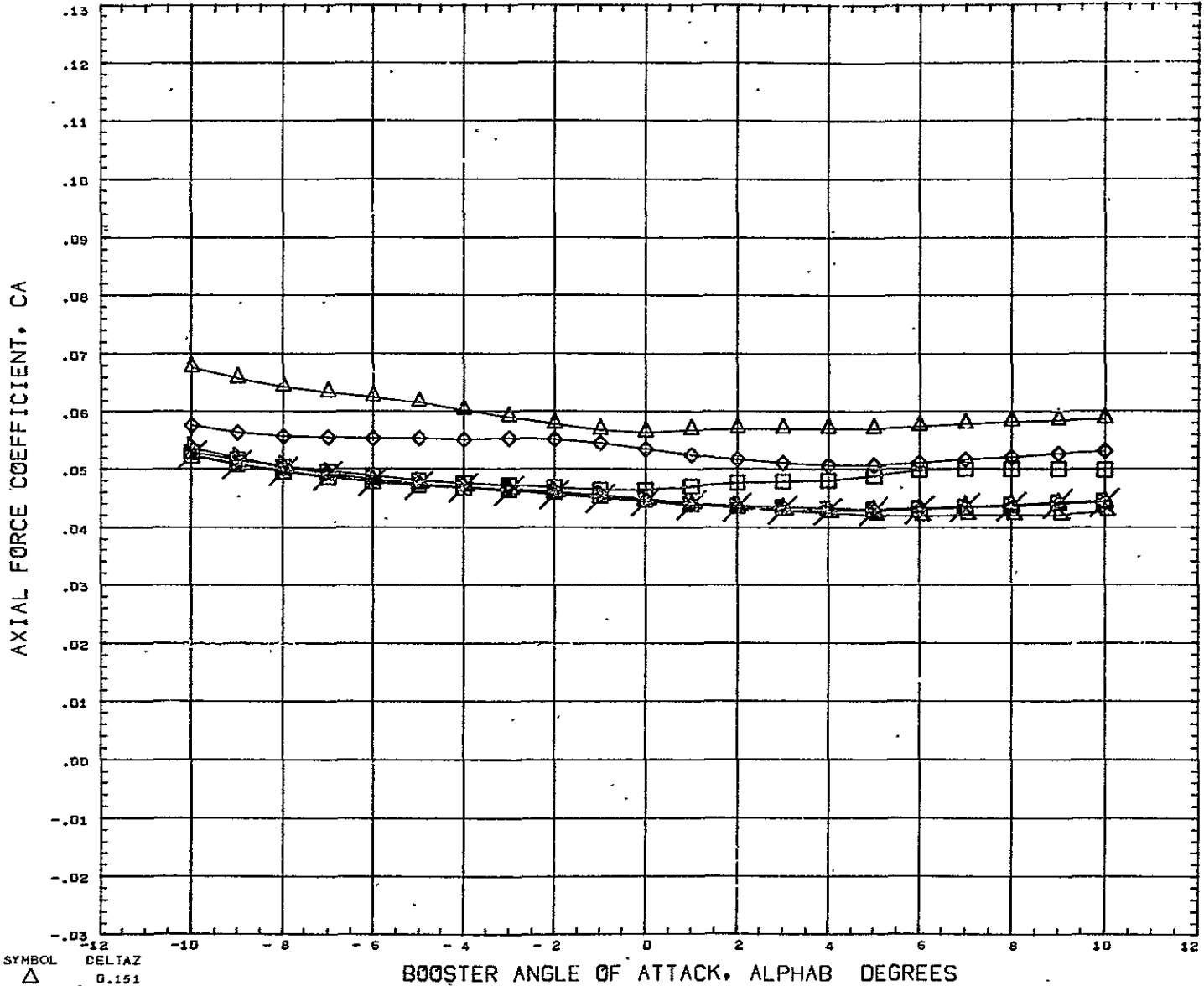

SYMBOL △ ◇ □ ○ ×	DELTAZ 0.151 0.182 0.228 0.352 0.599 10.000	<table border="0" style="width: 100%;"> <tr> <th colspan="4" style="text-align: left;">PARAMETRIC VALUES</th> </tr> <tr> <td style="width: 25%;">P3TPOW</td> <td style="width: 25%;">0.000</td> <td style="width: 25%;">ORBPOW</td> <td style="width: 25%;">0.000</td> </tr> <tr> <td>DELTA X</td> <td>0.105</td> <td>ALPHA I</td> <td>5.100</td> </tr> <tr> <td>MACH</td> <td>5.010</td> <td>ELVBST</td> <td>0.000</td> </tr> <tr> <td>ELVORB</td> <td>0.000</td> <td>BETA</td> <td>0.000</td> </tr> </table>	PARAMETRIC VALUES				P3TPOW	0.000	ORBPOW	0.000	DELTA X	0.105	ALPHA I	5.100	MACH	5.010	ELVBST	0.000	ELVORB	0.000	BETA	0.000	<table border="0" style="width: 100%;"> <tr> <th colspan="3" style="text-align: left;">REFERENCE INFORMATION</th> </tr> <tr> <td style="width: 30%;">REFS</td> <td style="width: 30%;">23.6890</td> <td style="width: 40%;">SQ IN</td> </tr> <tr> <td>REFL</td> <td>4.1930</td> <td>IN</td> </tr> <tr> <td>REFB</td> <td>6.5000</td> <td>IN</td> </tr> <tr> <td>XMRP</td> <td>4.9170</td> <td>IN</td> </tr> <tr> <td>YMRP</td> <td>0.0000</td> <td>IN</td> </tr> <tr> <td>ZMRP</td> <td>1.3900</td> <td>IN</td> </tr> <tr> <td>SCALE</td> <td>0.0055</td> <td></td> </tr> </table>	REFERENCE INFORMATION			REFS	23.6890	SQ IN	REFL	4.1930	IN	REFB	6.5000	IN	XMRP	4.9170	IN	YMRP	0.0000	IN	ZMRP	1.3900	IN	SCALE	0.0055	
PARAMETRIC VALUES																																															
P3TPOW	0.000	ORBPOW	0.000																																												
DELTA X	0.105	ALPHA I	5.100																																												
MACH	5.010	ELVBST	0.000																																												
ELVORB	0.000	BETA	0.000																																												
REFERENCE INFORMATION																																															
REFS	23.6890	SQ IN																																													
REFL	4.1930	IN																																													
REFB	6.5000	IN																																													
XMRP	4.9170	IN																																													
YMRP	0.0000	IN																																													
ZMRP	1.3900	IN																																													
SCALE	0.0055																																														

REFERENCE FILE



# AEDC VA 1163 MDAC BOOSTER AND ORBITER TEST DATA AT MACH NUMBER 5

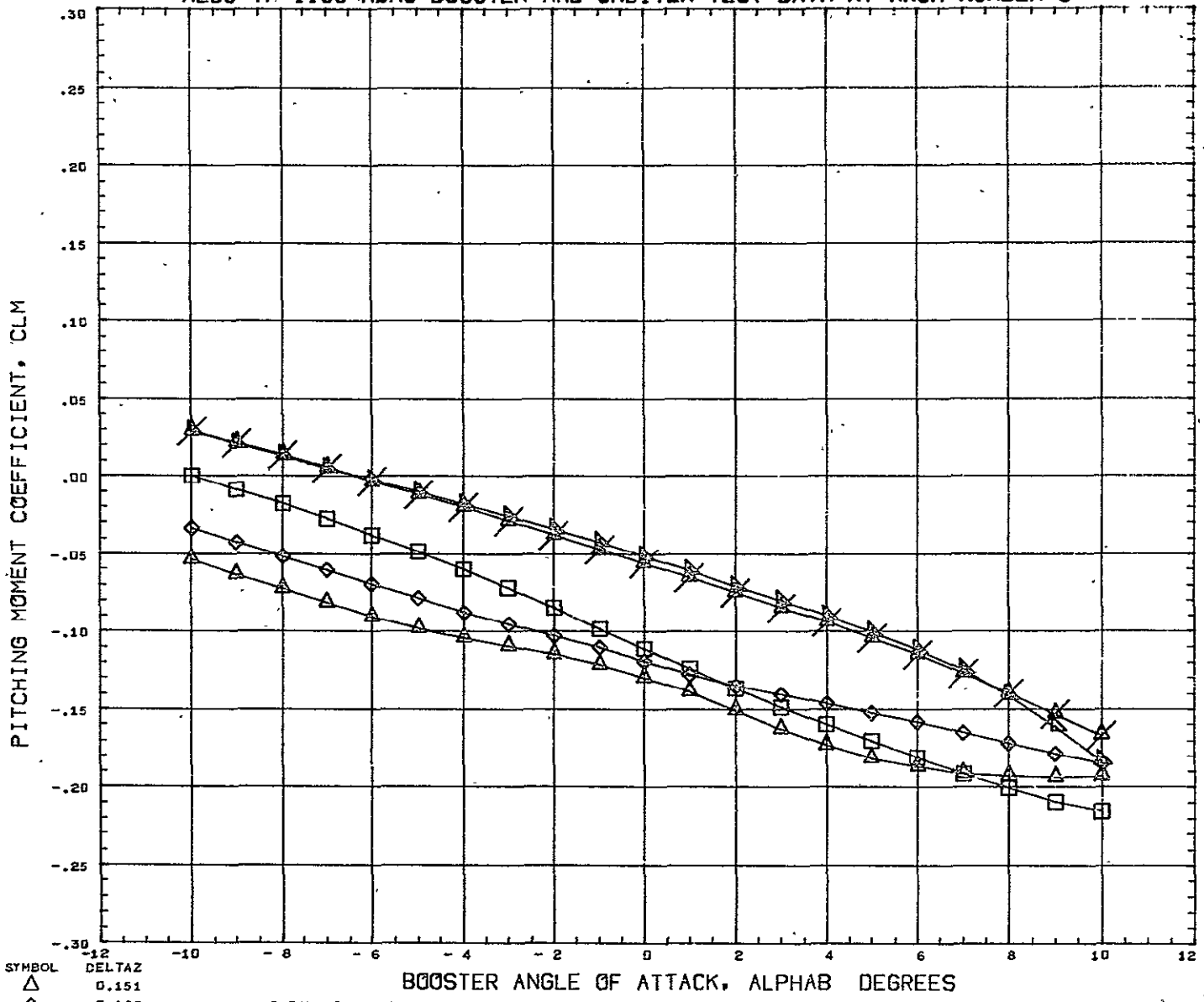

SYMBOL △ ◇ □ ▽ ×	DELTA Z 0.151 0.182 0.228 0.352 10.000	PARAMETRIC VALUES BSTPOW 0.000 ORBPOW 0.000 DELTAX 0.167 ALPHAI 5.100 MACH 5.010 ELVBST. 0.000 ELVORB 0.000 BETA 0.000	REFERENCE INFORMATION REFS 23.6890 SQ IN REFL 4.1930 IN REFB 6.5000 IN XMRF 4.9170 IN YMRF 0.0000 IN ZMRF 1.3900 IN SCALE 0.0055
---------------------------------	---	--	---

REFERENCE FILE

# AEDC VA 1163 MDAC BOOSTER AND ORBITER TEST DATA AT MACH NUMBER 5

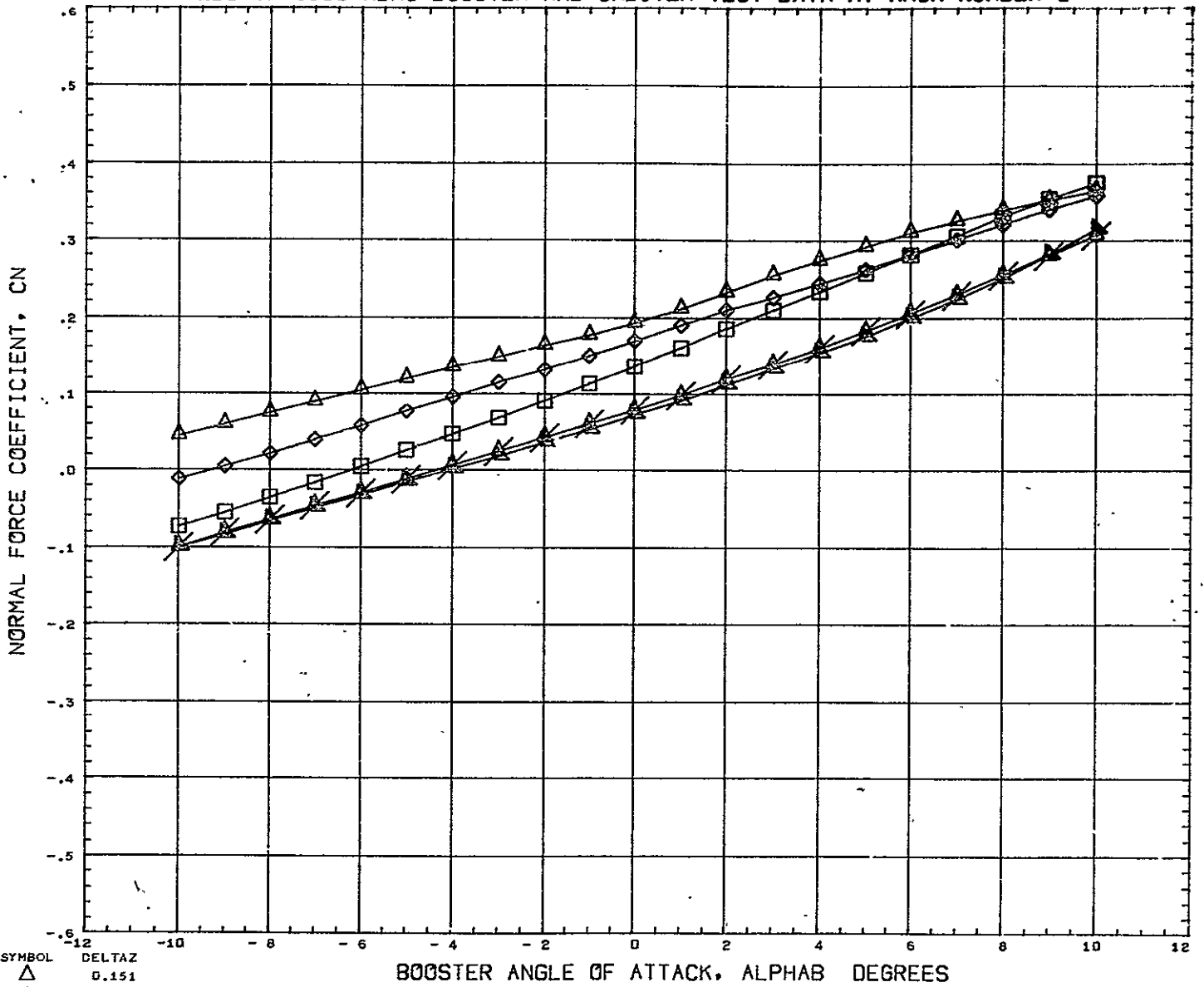

SYMBOL  
 △  
 ◇  
 □  
 ○  
 ×

DELTAZ  
 0.151  
 0.182  
 0.228  
 0.352  
 10.000

PARAMETRIC VALUES  
 BSTFOW 0.000 ORBPOW 0.000  
 DELTAX 0.167 ALPHAI 5.100  
 MACH 5.010 ELVBST 0.070  
 ELVORB 0.000 BETA 0.000

REFERENCE INFORMATION  
 REFS 23.6890 SQ IN  
 REFL 4.1930 IN  
 REFB 6.5000 IN  
 XHRP 4.917C IN  
 YHRP 0.0000 IN  
 ZHRP 1.3900 IN  
 SCALE 0.0055

REFERENCE FILE

# AEDC VA 1163 MDAC BOOSTER AND ORBITER TEST DATA AT MACH NUMBER 5

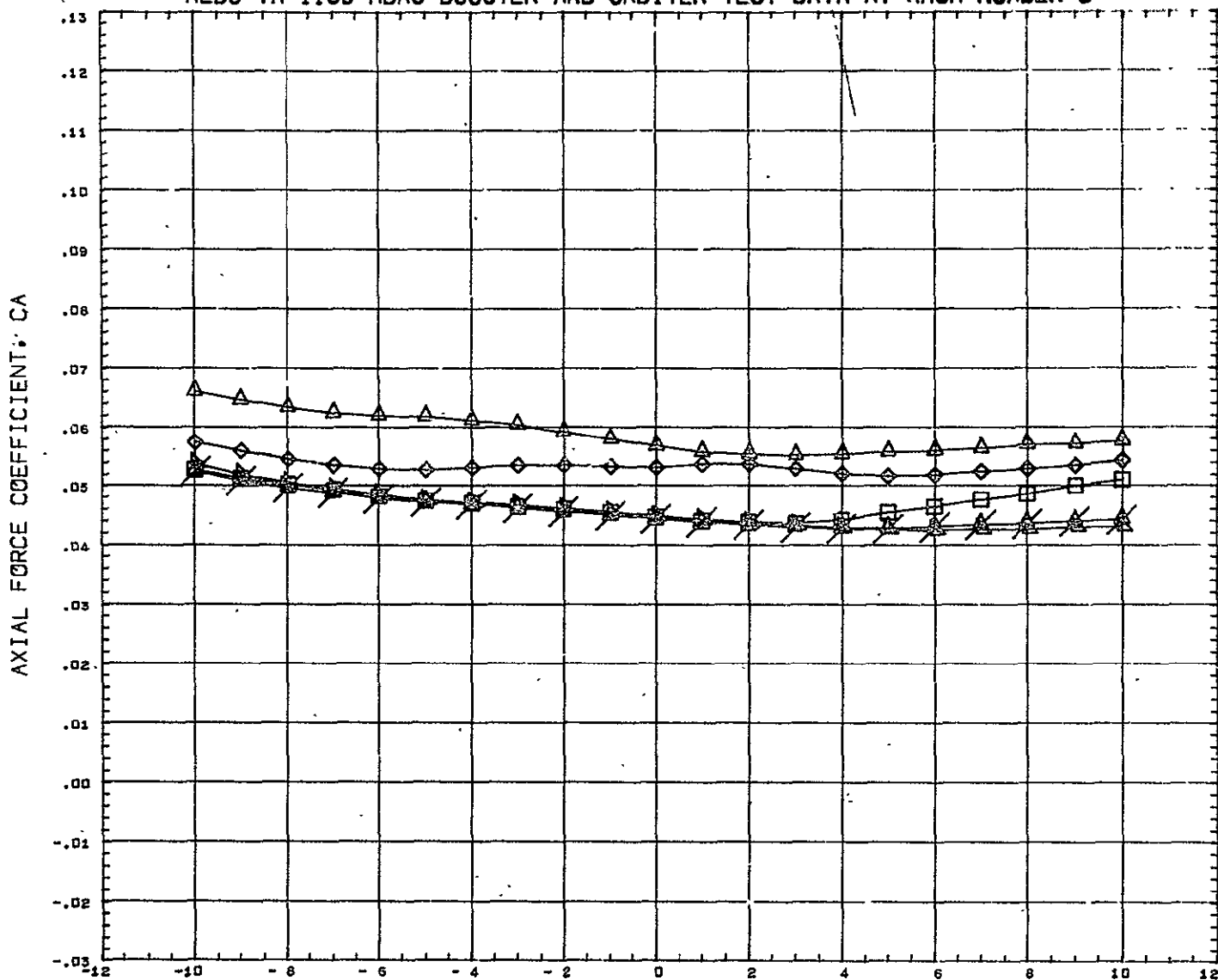

YMBOL	DELTAZ	PARAMETRIC VALUES				REFERENCE INFORMATION		
△	0.151	LSTPOW	0.000	ORBPOW	0.000	REFS	23.6890	SQ IN
◇	0.192	DELTAZ	0.167	ALPHAI	5.100	REFL	4.1330	IN
□	0.228	MACH	5.010	ELVBST	0.000	REFB	6.5000	IN
×	0.352	ELVORB	0.000	BETA	0.000	XMRP	4.9170	IN
△	10.000					YMRP	0.0000	IN
						ZMRP	1.3900	IN
						SCALE	0.0055	IN

REFERENCE FILE

# AEDC VA 1163 MDAC BOOSTER AND ORBITER TEST DATA AT MACH NUMBER 5

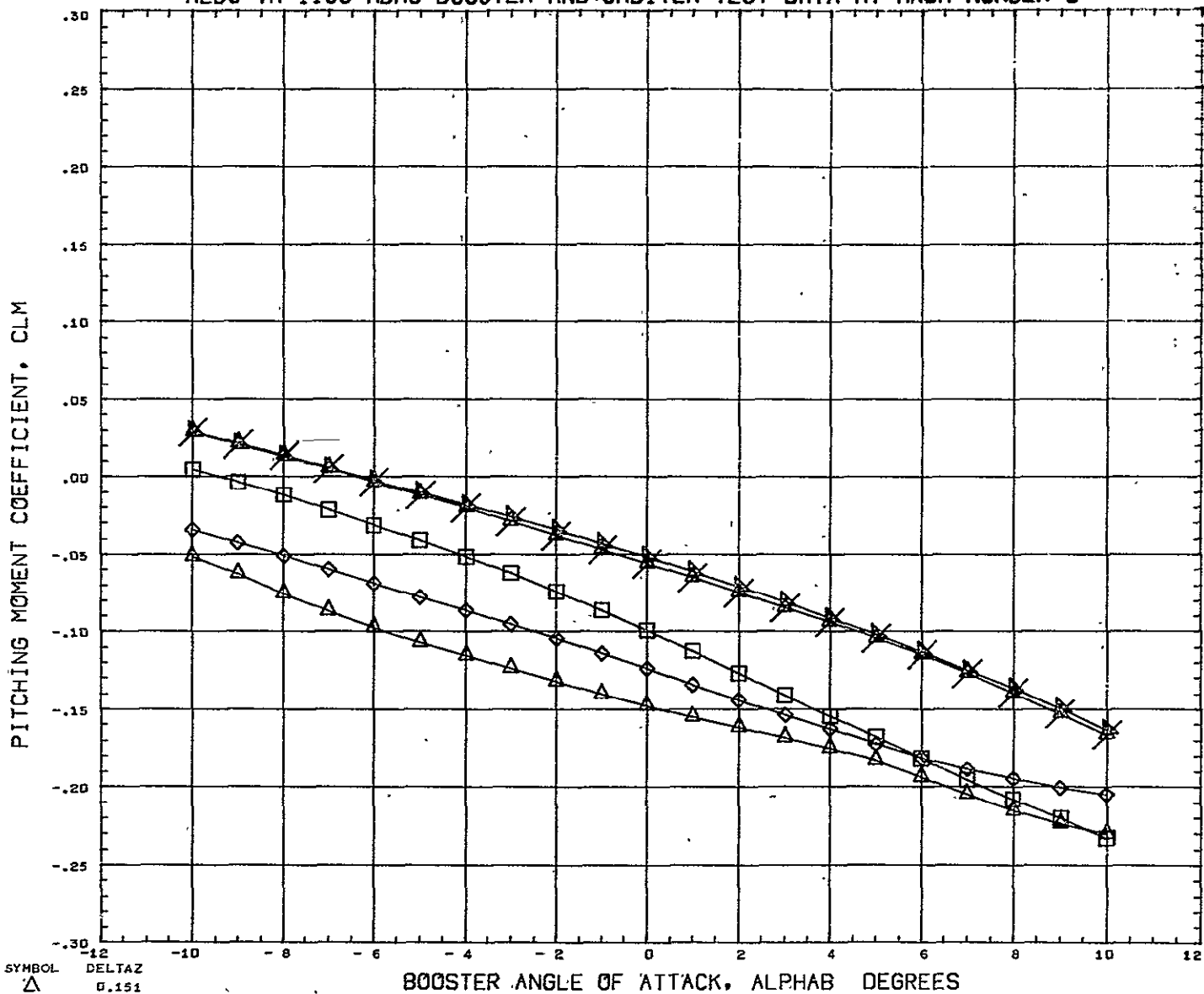

SYMBOL    DELTAZ  
 ◻        0.151  
 ◊        0.182  
 ◻        0.228  
 ◻        0.352  
 ◻        10.000

PARAMETRIC VALUES  
 BSTPOW    0.000    ORBPOW    0.000  
 DELTAX    0.228    ALPHAI    5.100  
 MACH       5.010    ELVBST    0.000  
 ELVORB    0.000    BETA       0.000

REFERENCE INFORMATION  
 REFS       23.6890    SQ IN  
 REFL       4.1930    IN  
 REFB       6.5000    IN  
 XMRP       4.9170    IN  
 YMRP       0.0000    IN  
 ZMRP       1.3900    IN  
 SCALE       0.0055

REFERENCE FILE

# AEDC VA 1163 MDAC BOOSTER AND ORBITER TEST DATA AT MACH NUMBER 5

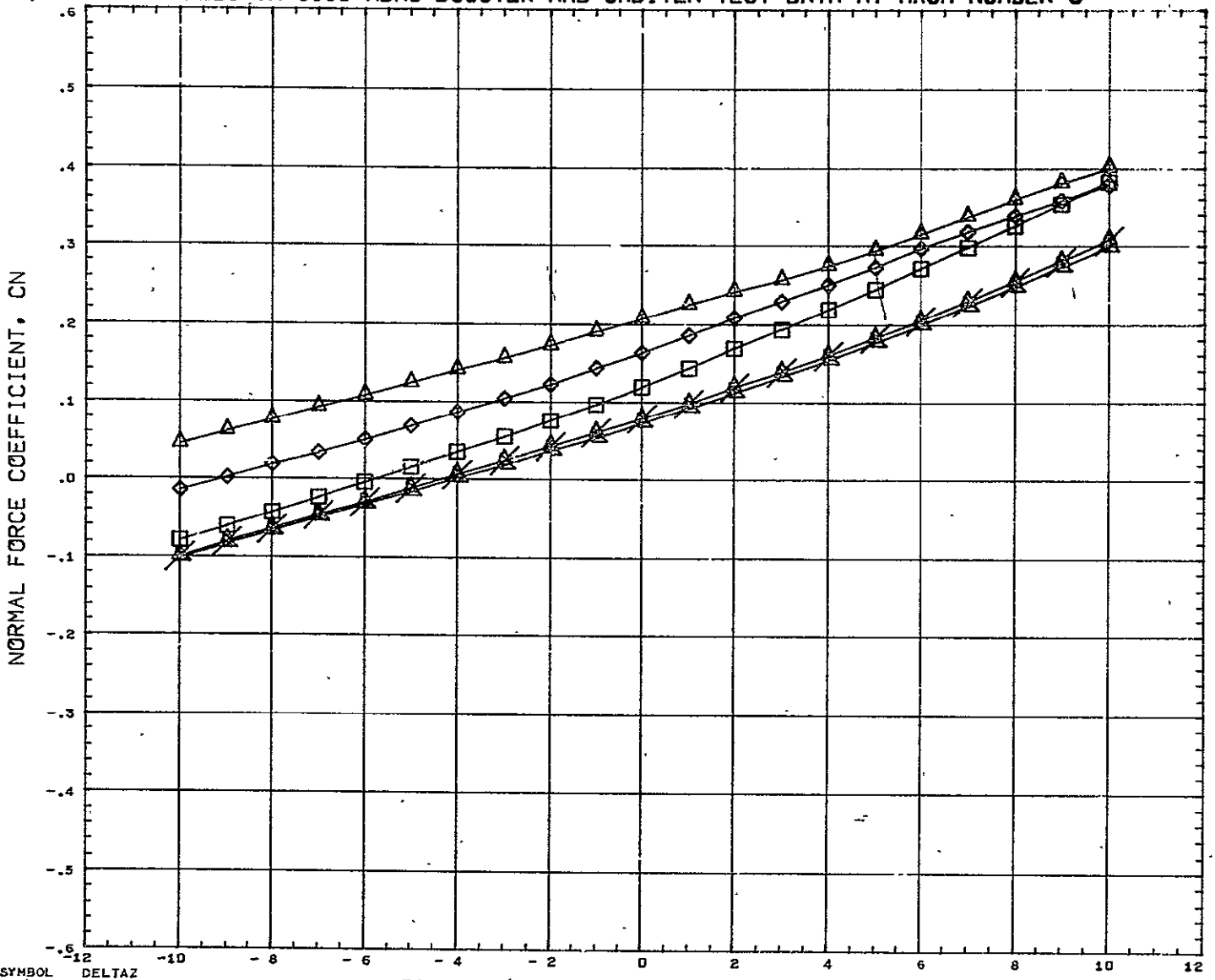

SYMBOL △ ◇ □ × *	DELTAZ 0.151 0.182 0.228 0.352 10.000	PARAMETRIC VALUES I, TPOW    0.000    ORBPOW    0.000 DELTAX    0.228    ALPHAI    5.100 MACH       5.010    ELVBST    0.000 ELVORB    0.000    BETA       0.000	REFERENCE INFORMATION REFS       23.6890    SQ IN REFL       4.1930    IN REFB       6.5005    IN XMRF       4.9170    IN YMRF       0.0000    IN ZMRF       1.3900    IN SCALE      0.0055
REFERENCE FILE			

# AEDC VA 1163 MDAC BOOSTER AND ORBITER TEST DATA AT MACH NUMBER 5

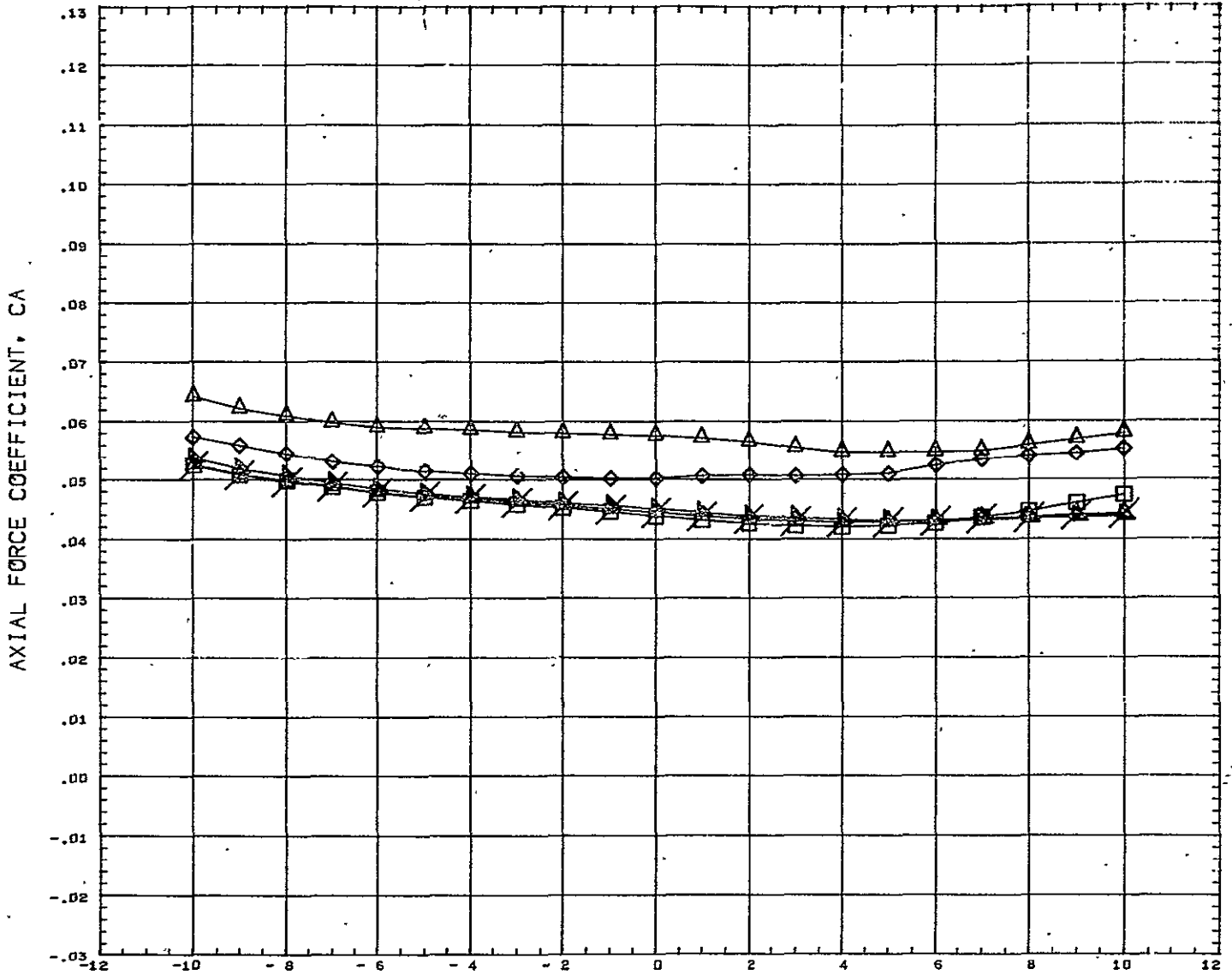

SYMBOL △ ◇ □ ×	DELTAZ 0.151 0.182 0.228 0.352 10.000	<table border="0" style="width: 100%;"> <tr> <th colspan="4" style="text-align: left;">PARAMETRIC VALUES</th> </tr> <tr> <td>STPOW</td><td>0.000</td><td>ORBPOW</td><td>0.000</td> </tr> <tr> <td>DELTA X</td><td>0.228</td><td>ALPHA I</td><td>5.100</td> </tr> <tr> <td>MACH</td><td>5.010</td><td>ELVBST</td><td>0.000</td> </tr> <tr> <td>ELVORB</td><td>0.000</td><td>BETA</td><td>0.000</td> </tr> </table>	PARAMETRIC VALUES				STPOW	0.000	ORBPOW	0.000	DELTA X	0.228	ALPHA I	5.100	MACH	5.010	ELVBST	0.000	ELVORB	0.000	BETA	0.000	<table border="0" style="width: 100%;"> <tr> <th colspan="3" style="text-align: left;">REFERENCE INFORMATION</th> </tr> <tr> <td>REFS</td><td>23.6890</td><td>SQ IN</td> </tr> <tr> <td>REFL</td><td>4.1930</td><td>IN</td> </tr> <tr> <td>REFB</td><td>6.5000</td><td>IN</td> </tr> <tr> <td>XMRP</td><td>4.9170</td><td>IN</td> </tr> <tr> <td>YMRP</td><td>0.0000</td><td>IN</td> </tr> <tr> <td>ZMRP</td><td>1.3900</td><td>IN</td> </tr> <tr> <td>SCALE</td><td>0.0055</td><td></td> </tr> </table>	REFERENCE INFORMATION			REFS	23.6890	SQ IN	REFL	4.1930	IN	REFB	6.5000	IN	XMRP	4.9170	IN	YMRP	0.0000	IN	ZMRP	1.3900	IN	SCALE	0.0055	
PARAMETRIC VALUES																																															
STPOW	0.000	ORBPOW	0.000																																												
DELTA X	0.228	ALPHA I	5.100																																												
MACH	5.010	ELVBST	0.000																																												
ELVORB	0.000	BETA	0.000																																												
REFERENCE INFORMATION																																															
REFS	23.6890	SQ IN																																													
REFL	4.1930	IN																																													
REFB	6.5000	IN																																													
XMRP	4.9170	IN																																													
YMRP	0.0000	IN																																													
ZMRP	1.3900	IN																																													
SCALE	0.0055																																														
REFERENCE FILE																																															

# AEDC VA 1163 MDAC BOOSTER AND ORBITER TEST DATA AT MACH NUMBER 5

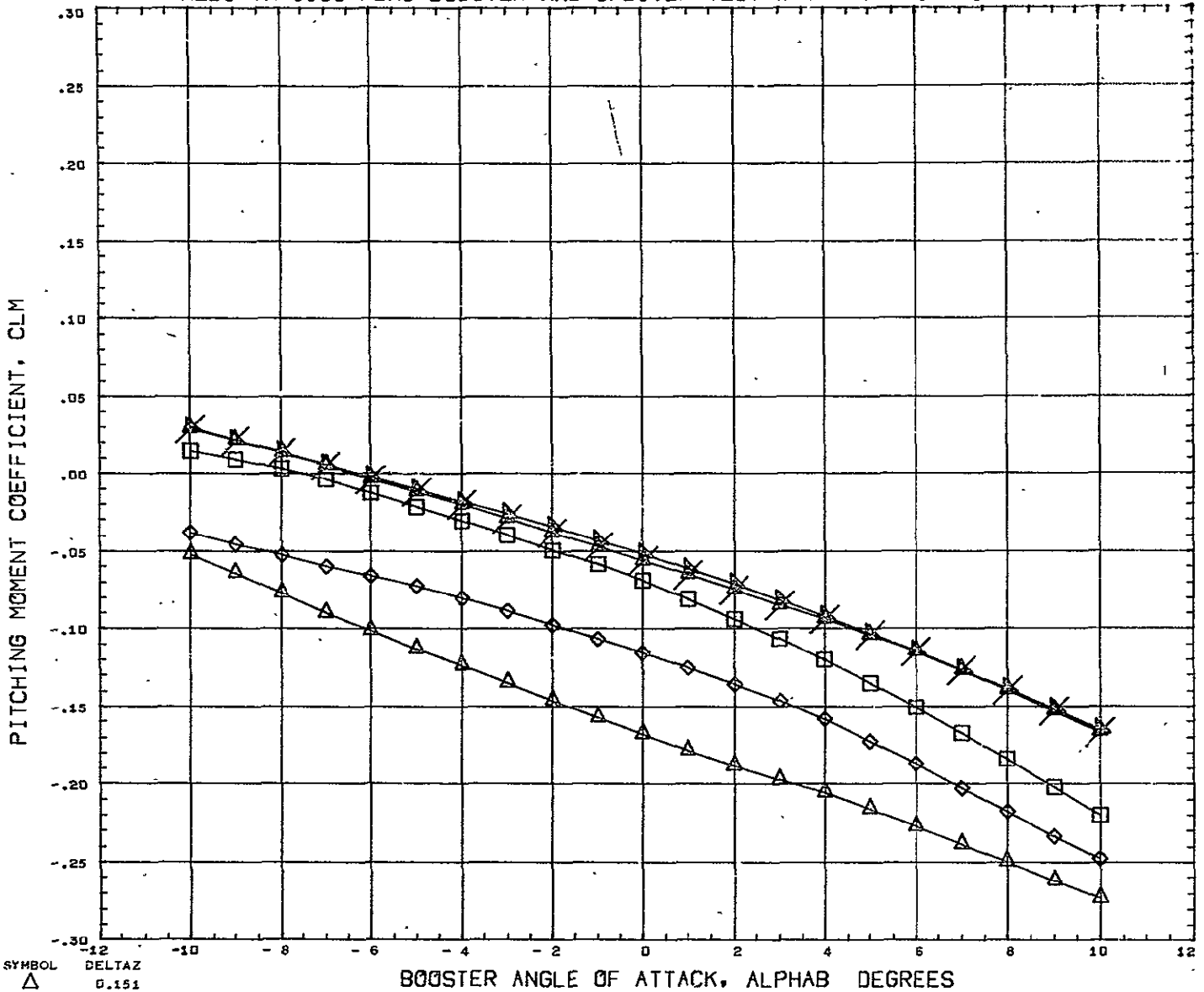

SYMBOL △ ◇ □ ×	DELTAZ 0.151 0.182 0.228 0.352 10.000	PARAMETRIC VALUES BSTFOW 0.000 ORBPOW 0.000 D.LLTAX 0.352 ALPHA 5.100 MACH 5.010 ELVBST 0.000 ELVORB 0.000 BETA 0.000	REFERENCE INFORMATION REFS 23.6890 SQ IN REFL 4.1930 IN REFB 6.5000 IN XHRP 4.9172 IN YHRP 0.0000 IN ZHRP 1.3900 IN SCALE 0.0055
REFERENCE FILE			

# AEDC VA 1163 MDAC BOOSTER AND ORBITER TEST DATA AT MACH NUMBER 5

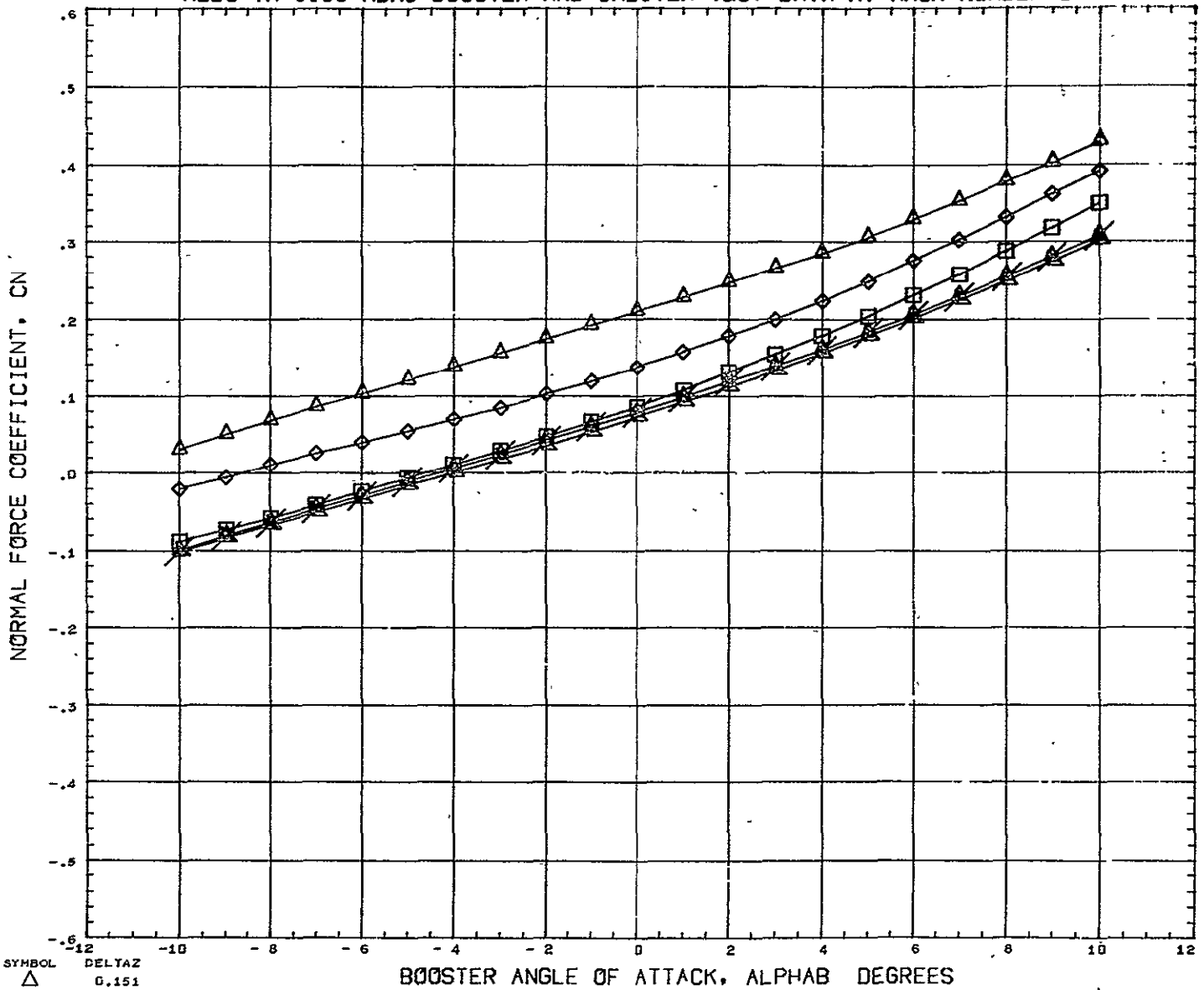

SYMBOL △ ◇ □ × *	DELTAZ 0.151 0.182 0.228 0.352 10.000	<b>PARAMETRIC VALUES</b> BSTPOW    0.000    ORBPOW    0.000 CLTAX     0.352    ALPHAI    5.100 MACH      5.010    ELVBST    0.000 ELVORB    0.000    BETA      0.000	<b>REFERENCE INFORMATION</b> REFS       23.6890    SQ IN REFL       4.1930    IN REFB       6.5000    IN XMRP       4.9170    IN YMRP       0.0000    IN ZMRP       1.3900    IN SCALE      0.0055
REFERENCE FILE			



# AEDC VA 1163 MDAC BOOSTER AND ORBITER TEST DATA AT MACH NUMBER 5

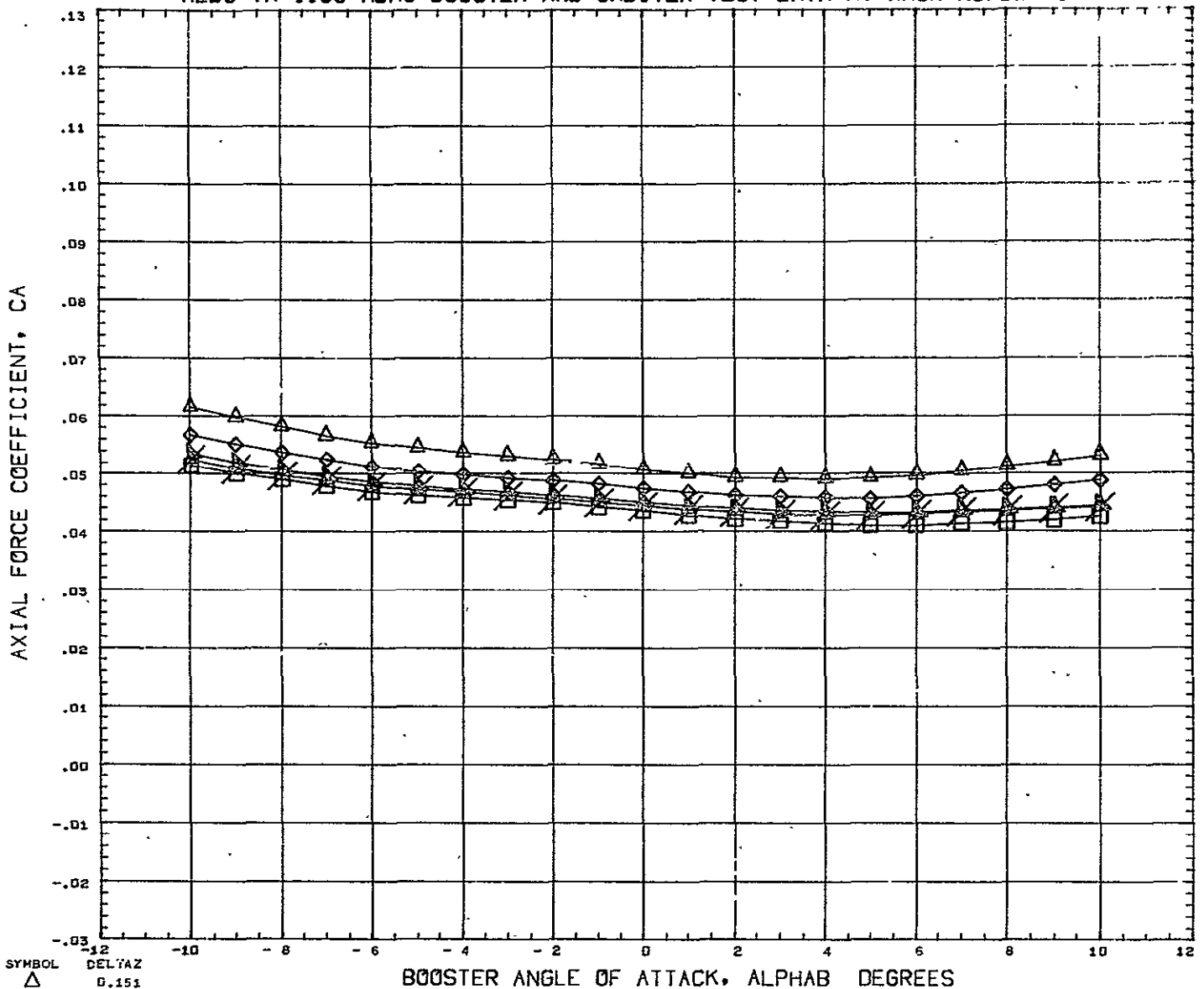

SYMBOL △ ◇ □ ▽ ⊠	DELTA Z 0.151 0.182 0.226 0.352 10.000	PARAMETRIC VALUES BSTPOW 0.000 ORBPOW 0.000 DELTAX 0.352 ALPHAI 5.100 MACH 5.010 ELVBST 0.000 ELVORD 0.000 BETA 0.000	REFERENCE INFORMATION REFS 23.6895 SQ IN REFL 4.1930 IN REFB 6.5000 IN XMRP 4.9175 IN YMRP 0.0000 IN ZMRP 1.3900 IN SCALE 0.0055
---------------------------------	---	---	---

REFERENCE FILE

# AEDC VA 1163 MDAC BOOSTER AND ORBITER TEST DATA AT MACH NUMBER 5

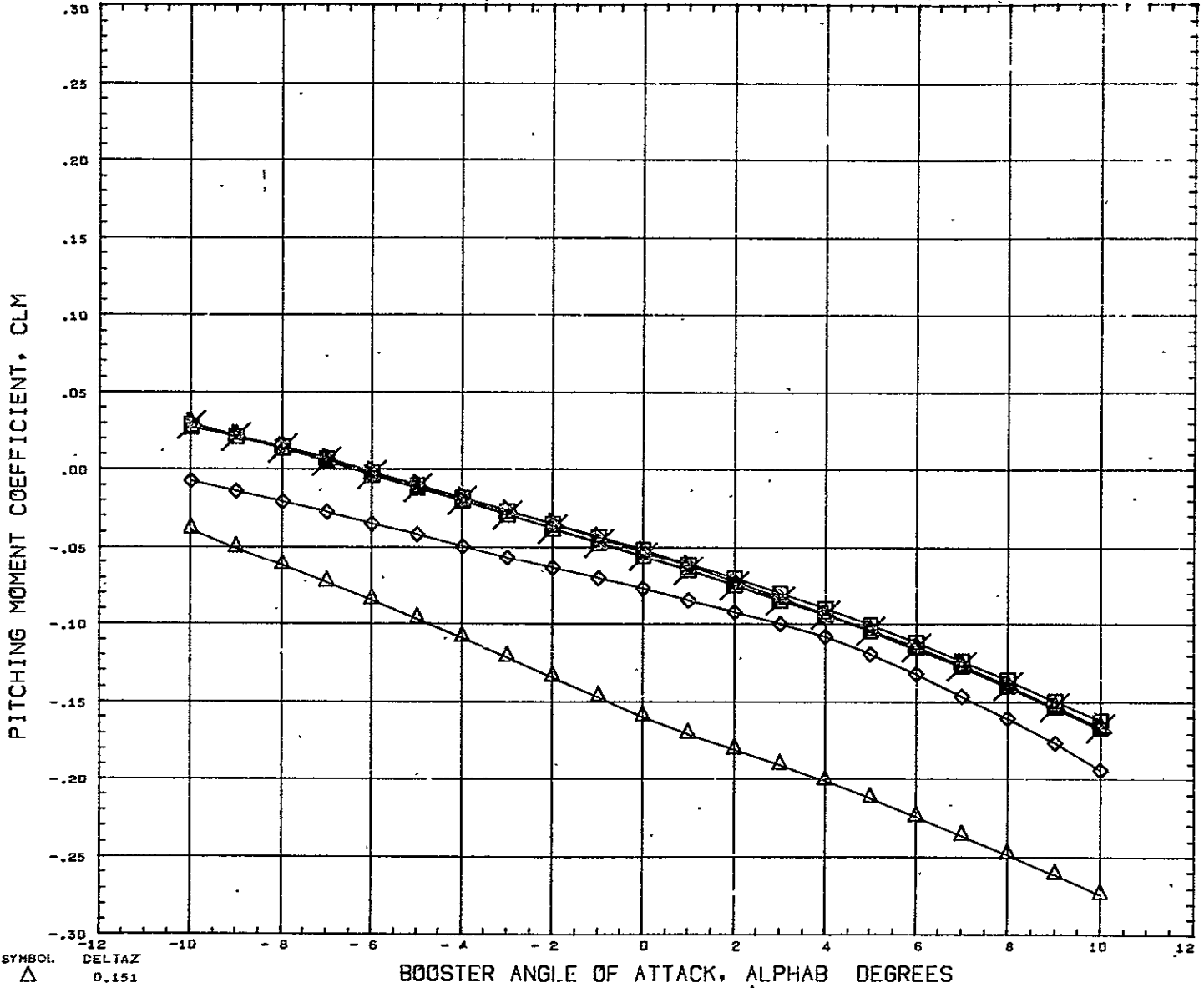

SYMBOL. DELTAZ  
 △ 0.151  
 ◇ 0.182  
 ◻ 0.228  
 ⊗ 0.352  
 ⊗ 0.599  
 ⊗ 10.000

PARAMETRIC VALUES  
 BSTFOW 0.000 ORBFOV 0.000  
 LELTAX 0.522 ALPHAI 5.100  
 MACH 5.010 ELVBST 0.000  
 ELVORB 0.000 BETA 0.000

REFERENCE INFORMATION  
 REFS 23.6890 SQ IN  
 REFL 4.1930 IN  
 REFB 6.5000 IN  
 XMRP 4.9170 IN  
 YMRP 0.0000 IN  
 ZMRP 1.3900 IN  
 SCALE 0.0055

REFERENCE FILE

# AEDC VA 1163 MDAC BOOSTER AND ORBITER TEST DATA AT MACH NUMBER 5

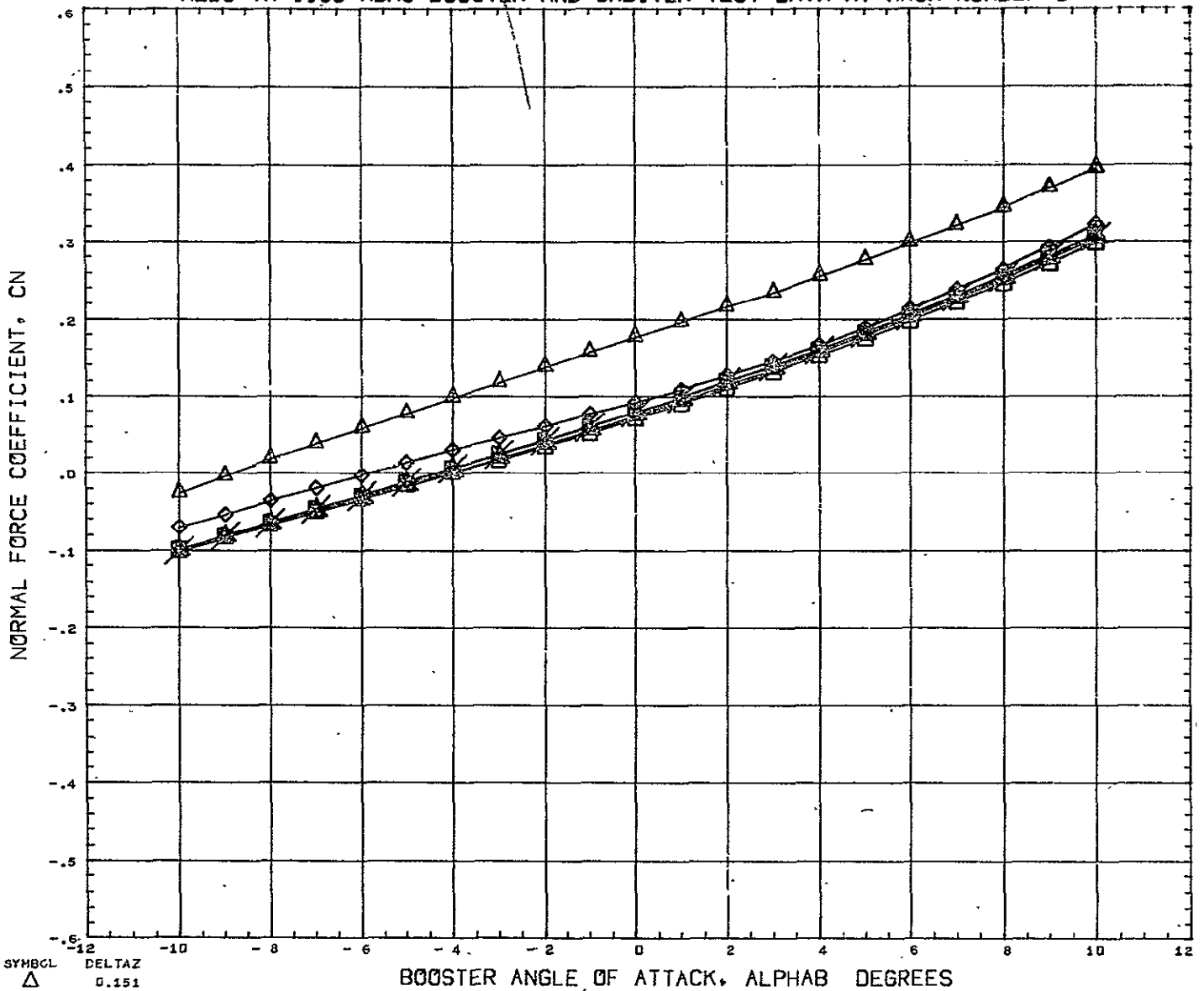

SYMBGL △ ◇ □ ○ ×	DELTAZ 0.151 0.182 0.228 0.352 0.599 10.000	PARAMETRIC VALUES RSTPOW    0.000    ORBPOW    0.000 DELTAX    0.522    ALPHAI    5.100 MACH       5.010    ELVBST    0.000 ELVORB    0.000    BETA       0.000	REFERENCE INFORMATION REFS       23.6690    SQ IN REFL       4.1930    IN REFB       6.5000    IN XMRP       4.9170    IN YMRP       0.0000    IN ZMRP       1.3900    IN SCALE      0.0055
---------------------------------	---	---	--

REFERENCE FILE

# AEDC VA 1163 MDAC BOOSTER AND ORBITER TEST DATA AT MACH NUMBER 5

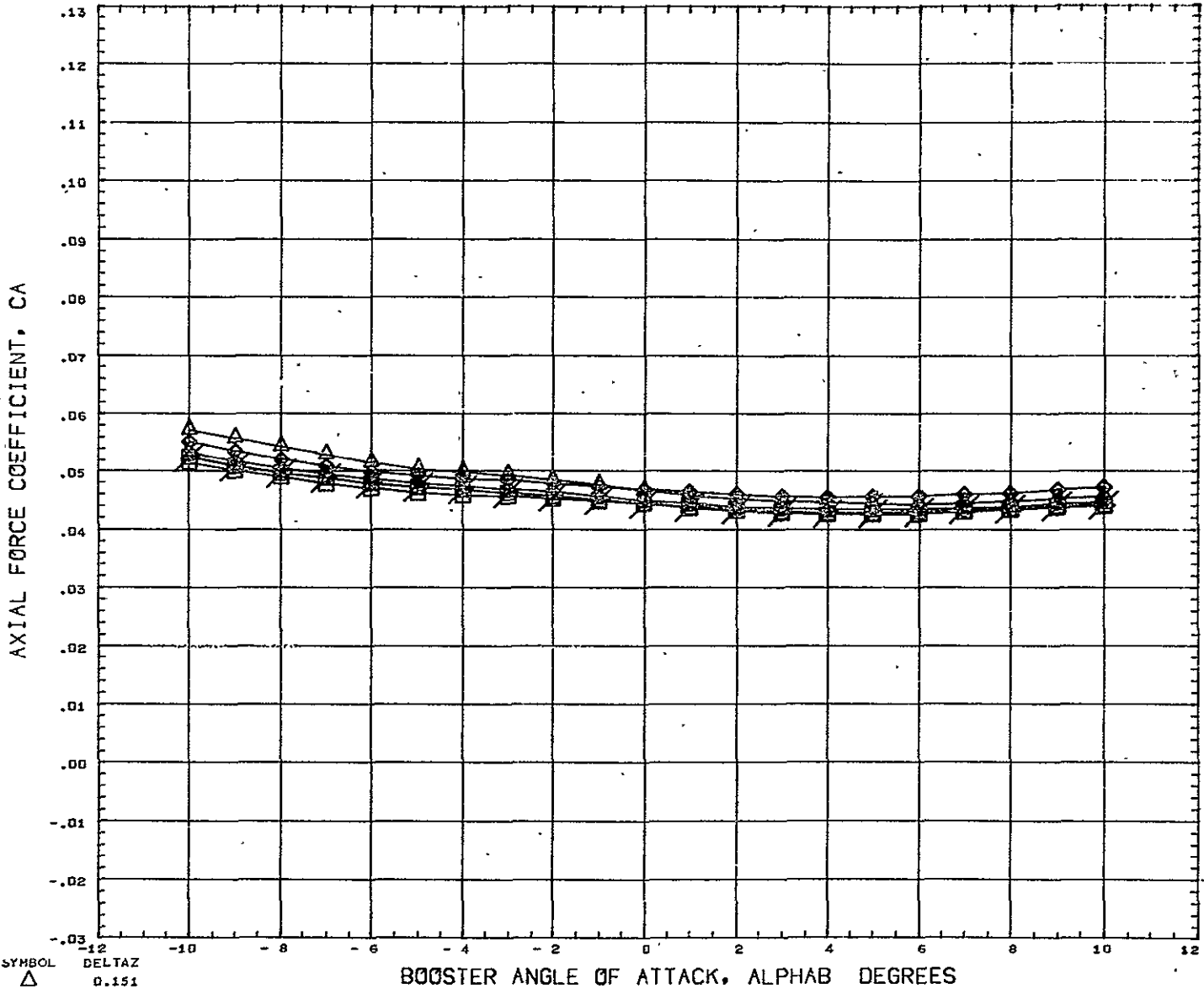

SYMBOL △ ◇ □ ◊ ⊠ ⊞	DELTAX 0.151 0.182 0.228 0.352 0.599 10.000	PARAMETRIC VALUES B <sup>∞</sup> TPOW    0.000    ORBPOW    0.000 DELTAX    0.522    ALPHAI    5.100 MACH      5.010    ELVBST    0.000 ELVORB    0.000    BETA      0.000	REFERENCE INFORMATION REFS      23.6890    SQ IN REFL      4.1930    IN REFB      6.5000    IN XMRP      4.9170    IN YMRP      0.0000    IN ZMRP      1.3900    IN SCALE     0.0055
--------------------------------------	---	--	---

REFERENCE FILE

# AEDC VA 1163 MDAC BOOSTER AND ORBITER TEST DATA AT MACH NUMBER 5

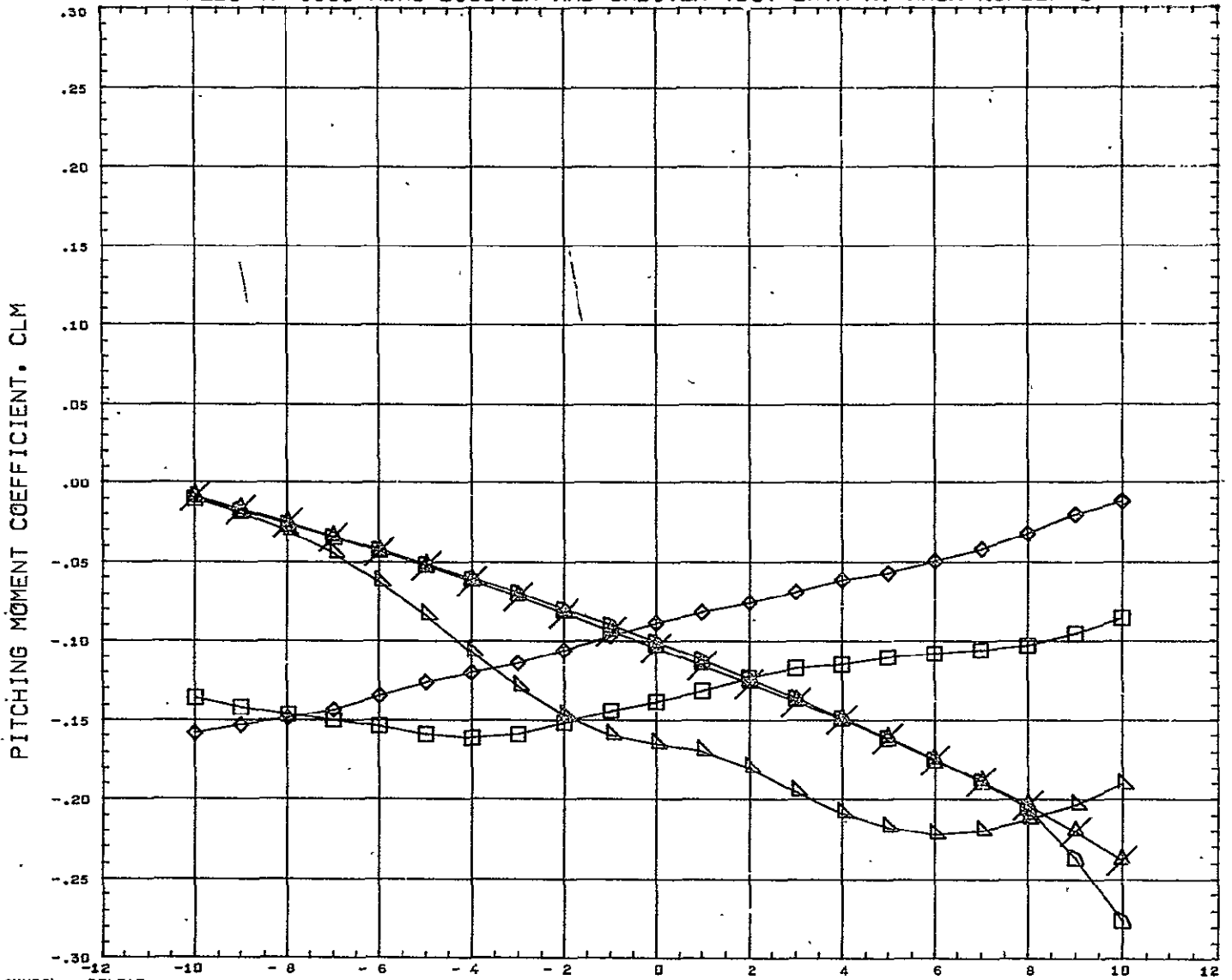

SYMBOL ◇ □ △ ×	DELTAZ 0.182 0.228 0.352 0.599 10.000 ELVORB	PARAMETRIC VALUES PSTPOW 0.000 ORBPOW 0.000 DELTAX 0.391 ALPHAI 10.100 MACH 5.010 ELVBST 0.000 BETA 0.000	REFERENCE INFORMATION REFS 23.6890 SQ IN REFL 4.1930 IN REFB 6.5000 IN XMRP 4.9170 IN YMRP 0.0000 IN ZMRP 1.3900 IN SCALE 0.0055
REFERENCE FILE			

# AEDC VA 1163 MDAC BOOSTER AND ORBITER TEST DATA AT MACH NUMBER 5

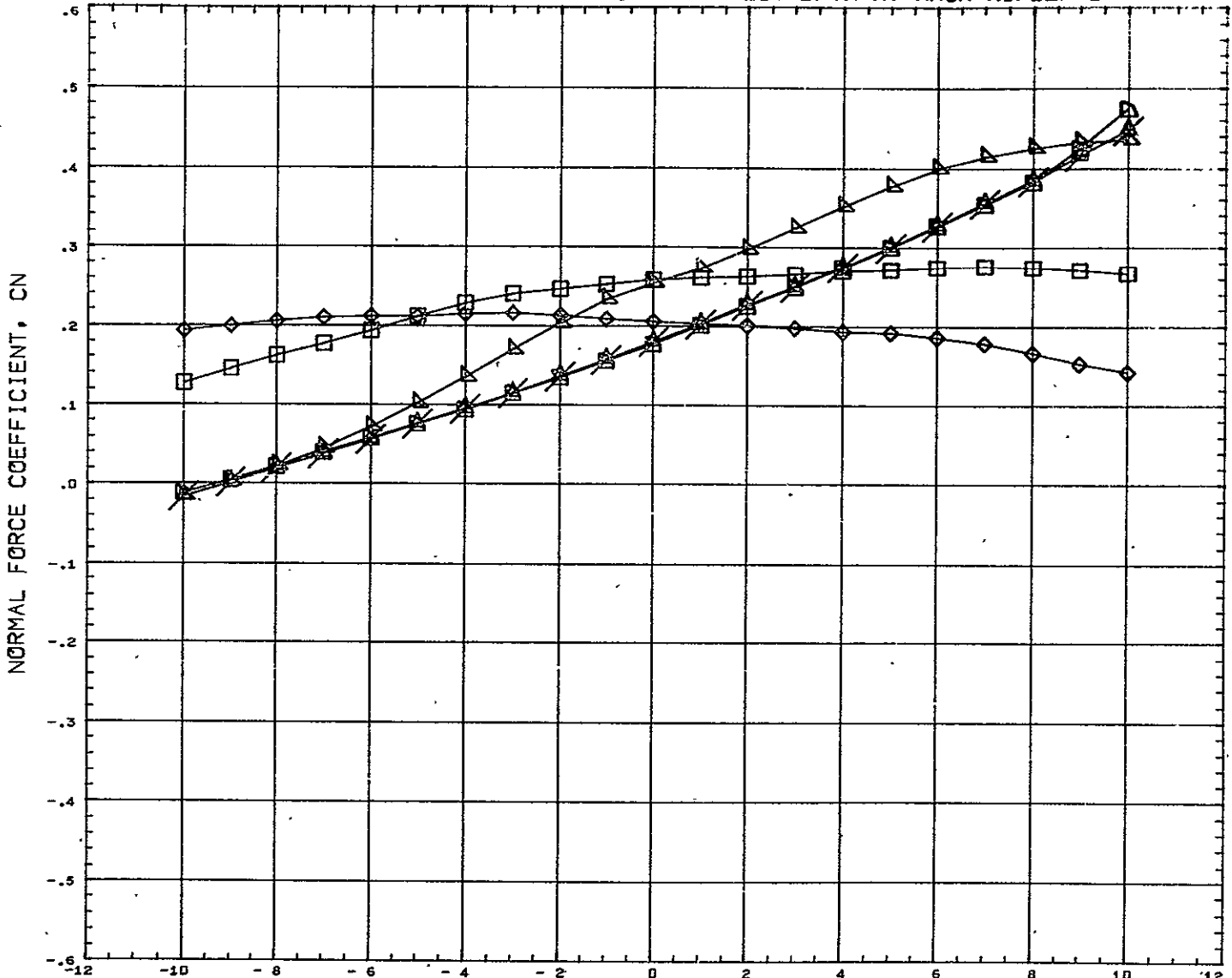

SYMBOL 	DELTA Z 0.182 0.228 0.352 0.599 10.000	<b>PARAMETRIC VALUES</b> PSTFOW 0.000 ORBPOW 0.000 DELTAX - 0.391 ALPHAI 10.100 MACH 5.010 ELVBST 0.000 ELVORB 0.000 BETA 0.000	<b>REFERENCE INFORMATION</b> REFS 23.6000 SQ IN REFL 4.1930 IN REFB 6.5000 IN XMRP 4.9170 IN YMRP 0.0000 IN ZMRP 1.3900 IN SCALE 0.0055
REFERENCE FILE			

# AEDC VA 1163 MDAC BOOSTER AND ORBITER TEST DATA AT MACH NUMBER 5

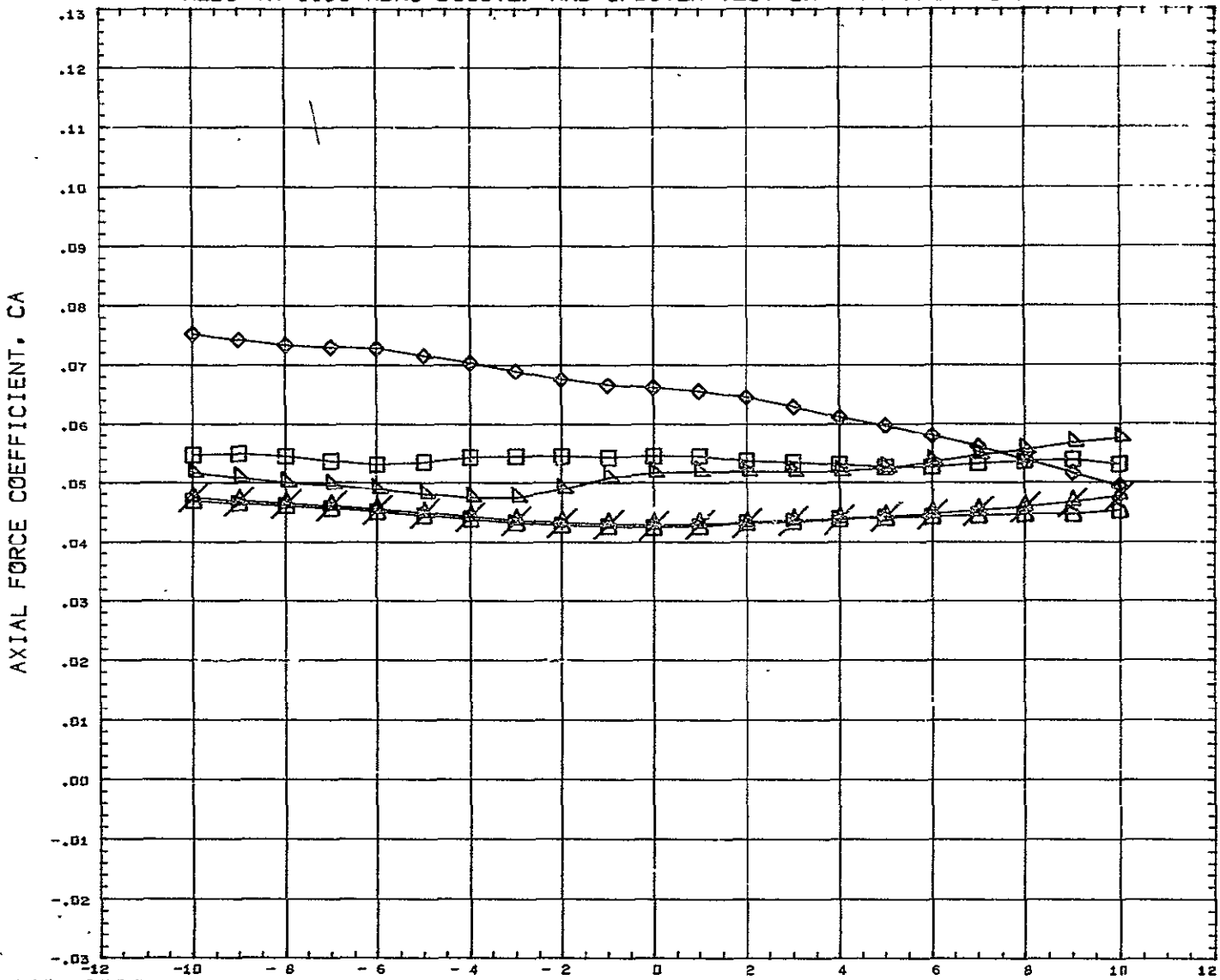

SYMBOL ◇ □ △ × ▽	DELTAZ 0.182 0.228 0.352 0.599 10.000	<table border="0" style="width: 100%;"> <tr> <th colspan="4" style="text-align: left;">PARAMETRIC VALUES</th> </tr> <tr> <td style="width: 25%;">B**POW</td> <td style="width: 25%;">0.000</td> <td style="width: 25%;">ORBPOW</td> <td style="width: 25%;">0.000</td> </tr> <tr> <td>DELTA X</td> <td>0.391</td> <td>ALFHAI</td> <td>10.100</td> </tr> <tr> <td>MACH</td> <td>5.010</td> <td>ELVBST</td> <td>0.000</td> </tr> <tr> <td>ELVORB</td> <td>0.000</td> <td>BETA</td> <td>0.000</td> </tr> </table>	PARAMETRIC VALUES				B**POW	0.000	ORBPOW	0.000	DELTA X	0.391	ALFHAI	10.100	MACH	5.010	ELVBST	0.000	ELVORB	0.000	BETA	0.000	<table border="0" style="width: 100%;"> <tr> <th colspan="3" style="text-align: left;">REFERENCE INFORMATION</th> </tr> <tr> <td>REFS</td> <td>23.6890</td> <td>SQ IN</td> </tr> <tr> <td>REFL</td> <td>4.1930</td> <td>IN</td> </tr> <tr> <td>REFB</td> <td>6.5000</td> <td>IN</td> </tr> <tr> <td>XMRP</td> <td>4.9170</td> <td>IN</td> </tr> <tr> <td>YMRP</td> <td>0.0000</td> <td>IN</td> </tr> <tr> <td>ZMRP</td> <td>1.3900</td> <td>IN</td> </tr> <tr> <td>SCALE</td> <td>0.0055</td> <td></td> </tr> </table>	REFERENCE INFORMATION			REFS	23.6890	SQ IN	REFL	4.1930	IN	REFB	6.5000	IN	XMRP	4.9170	IN	YMRP	0.0000	IN	ZMRP	1.3900	IN	SCALE	0.0055	
PARAMETRIC VALUES																																															
B**POW	0.000	ORBPOW	0.000																																												
DELTA X	0.391	ALFHAI	10.100																																												
MACH	5.010	ELVBST	0.000																																												
ELVORB	0.000	BETA	0.000																																												
REFERENCE INFORMATION																																															
REFS	23.6890	SQ IN																																													
REFL	4.1930	IN																																													
REFB	6.5000	IN																																													
XMRP	4.9170	IN																																													
YMRP	0.0000	IN																																													
ZMRP	1.3900	IN																																													
SCALE	0.0055																																														

REFERENCE FILE

# AEDC VA 1163 MDAC BOOSTER AND ORBITER TEST DATA AT MACH NUMBER 5

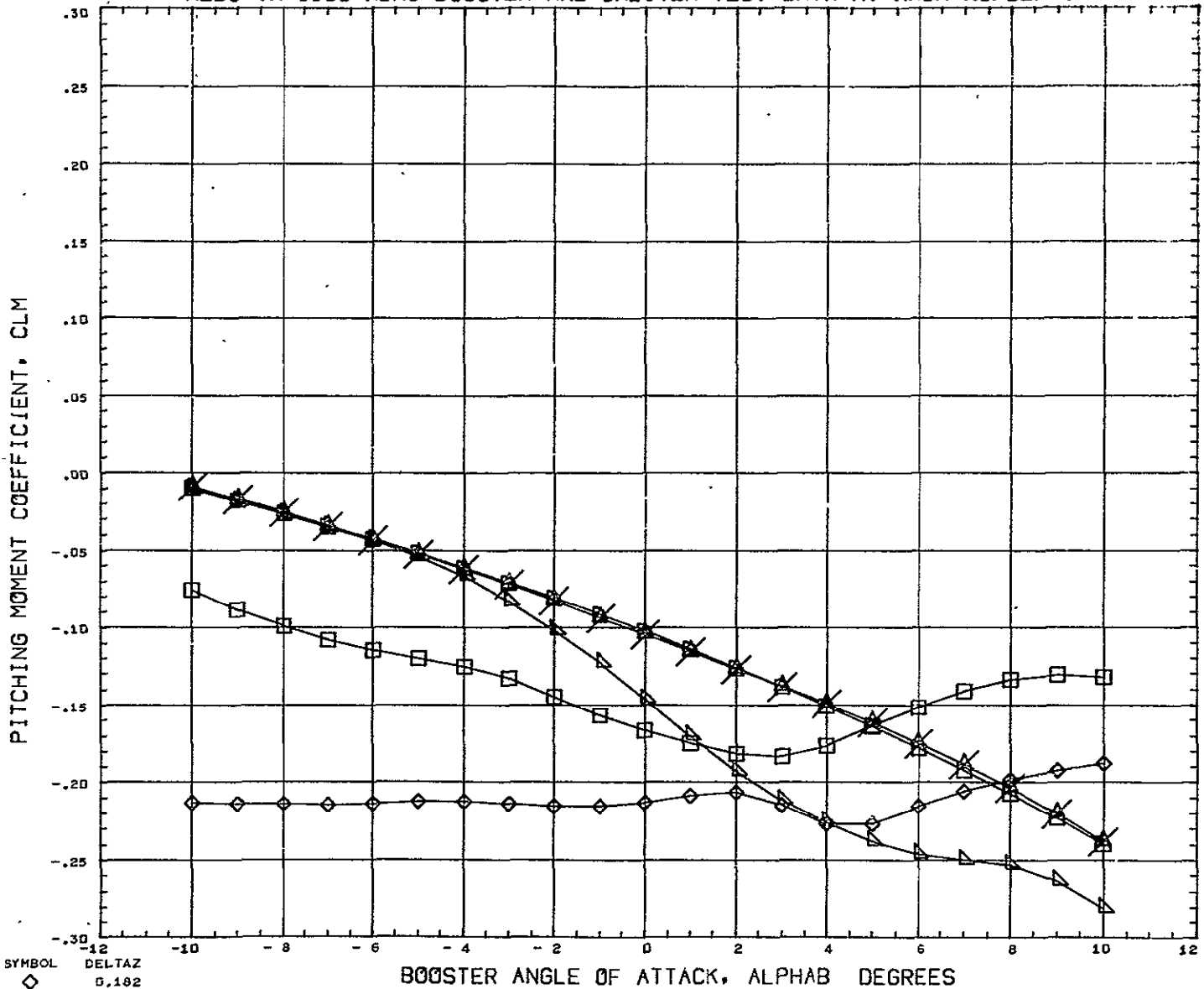

SYMBOL 	DELTAZ 0.192 0.228 0.352 0.599 10.000	PARAMETRIC VALUES BFTPOW 0.000 DELTAX - 0.143 MACH 5.010 ELVORB 0.000 ORBPOM 0.000 ALPHAI 10.100 ELVBST 0.000 BETA 0.000	REFERENCE INFORMATION REFS 23.6890 SQ IN REFL 4.1930 IN REFB 6.5000 IN XMRP 4.9170 IN YMRP 0.0000 IN ZMRP 1.3900 IN SCALE 0.0055
REFERENCE FILE			



# AEDC VA 1163 MDAC BOOSTER AND ORBITER TEST DATA AT MACH NUMBER 5

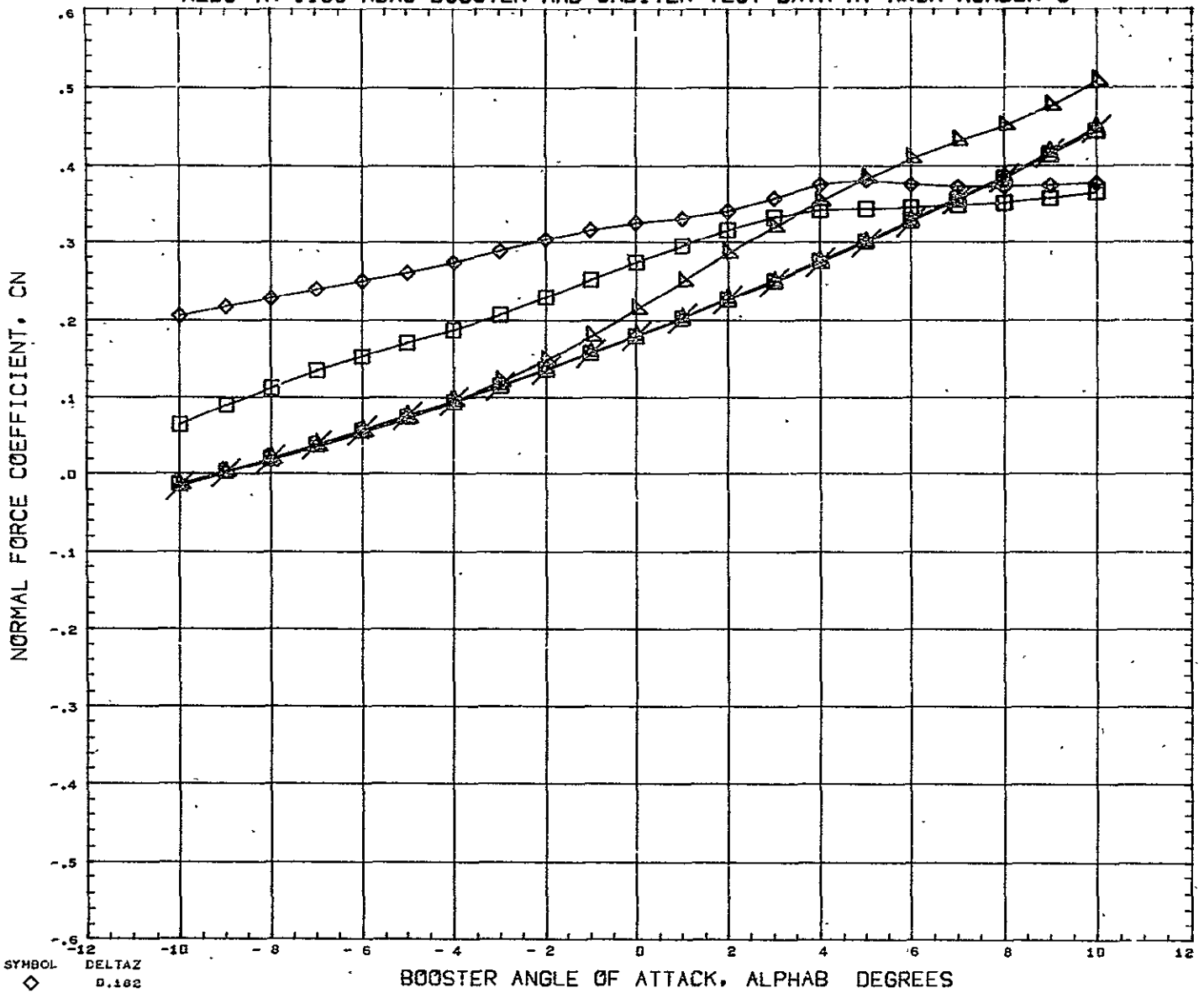

SYMBOL ◇ □ △ ×	DELTAZ 0.162 0.228 0.352 0.599 10.000	PARAMETRIC VALUES E TPOW    0.000    ORBFOW    0.000 DELTAX    - 0.143    ALPHAI    10.100 MACH       5.010    ELVEST    0.000 ELVORB    0.000    BETA       0.000	REFERENCE INFORMATION REFS       23.6890    SQ IN REFL       4.1930    IN REFB       6.5000    IN XMRP       4.9170    IN YMRP       0.0000    IN ZMRP       1.3900    IN SCALE       0.0055
REFERENCE FILE			

# AEDC VA 1163 MDAC BOOSTER AND ORBITER TEST DATA AT MACH NUMBER 5

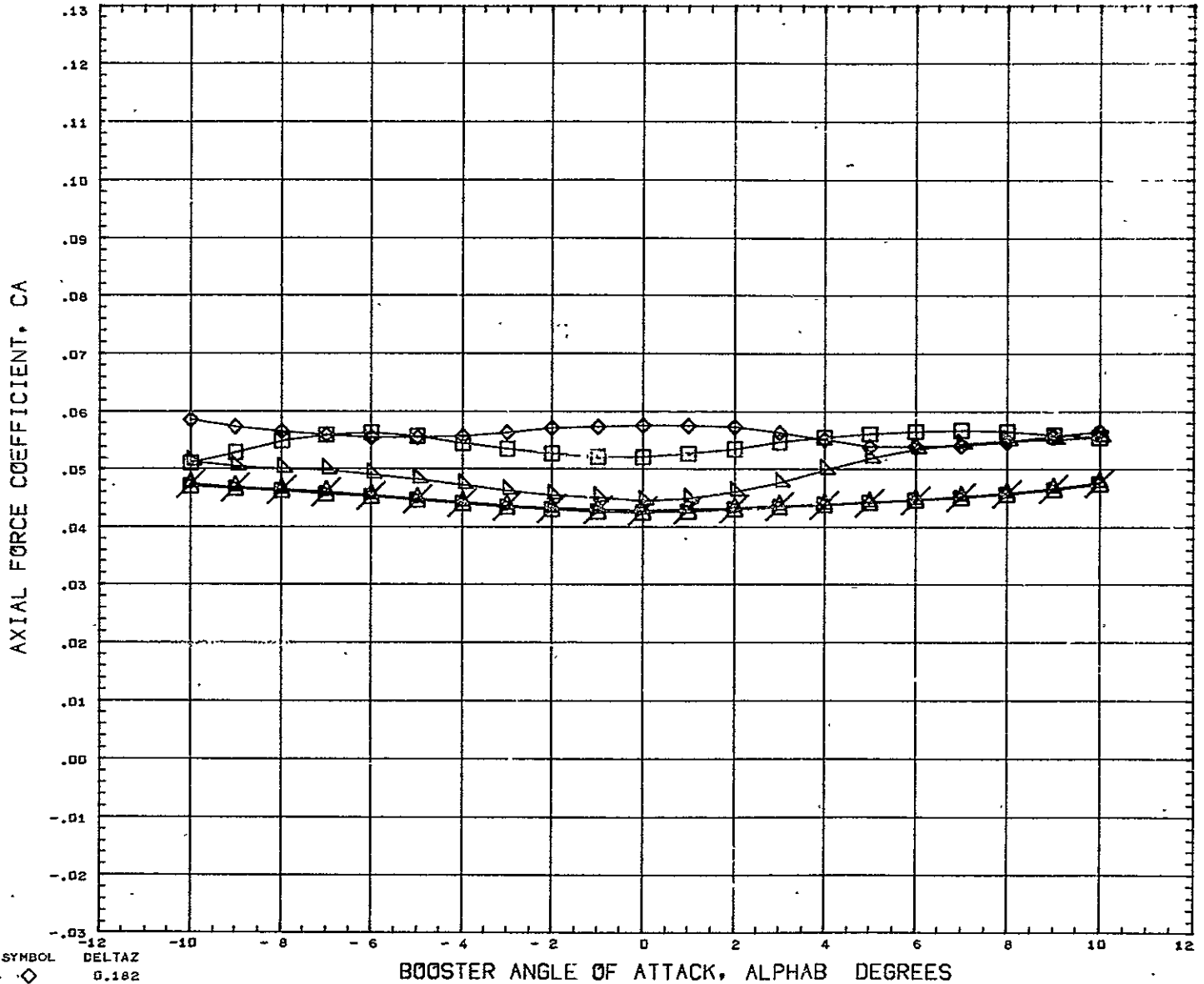

SYMBOL	DELTAZ 0.182 0.228 0.352 0.599 10.000	<table border="0" style="width: 100%;"> <tr> <th colspan="4" style="text-align: left;">PARAMETRIC VALUES</th> </tr> <tr> <td>PSTPOW</td><td>0.000</td><td>ORBPOW</td><td>0.000</td> </tr> <tr> <td>DELTAZ</td><td>-0.143</td><td>ALPHAI</td><td>10.100</td> </tr> <tr> <td>MACH</td><td>5.010</td><td>ELVBSST</td><td>0.000</td> </tr> <tr> <td>ELVORB</td><td>0.000</td><td>BETA</td><td>0.000</td> </tr> </table>	PARAMETRIC VALUES				PSTPOW	0.000	ORBPOW	0.000	DELTAZ	-0.143	ALPHAI	10.100	MACH	5.010	ELVBSST	0.000	ELVORB	0.000	BETA	0.000	<table border="0" style="width: 100%;"> <tr> <th colspan="3" style="text-align: left;">REFERENCE INFORMATION</th> </tr> <tr> <td>REFS</td><td>23.6890</td><td>SQ IN</td> </tr> <tr> <td>REFL</td><td>4.1930</td><td>IN</td> </tr> <tr> <td>REFB</td><td>6.5000</td><td>IN</td> </tr> <tr> <td>XMRP</td><td>4.9170</td><td>IN</td> </tr> <tr> <td>YMRP</td><td>0.0000</td><td>IN</td> </tr> <tr> <td>ZMRP</td><td>1.3900</td><td>IN</td> </tr> <tr> <td>SCALE</td><td>0.0055</td><td></td> </tr> </table>	REFERENCE INFORMATION			REFS	23.6890	SQ IN	REFL	4.1930	IN	REFB	6.5000	IN	XMRP	4.9170	IN	YMRP	0.0000	IN	ZMRP	1.3900	IN	SCALE	0.0055	
PARAMETRIC VALUES																																															
PSTPOW	0.000	ORBPOW	0.000																																												
DELTAZ	-0.143	ALPHAI	10.100																																												
MACH	5.010	ELVBSST	0.000																																												
ELVORB	0.000	BETA	0.000																																												
REFERENCE INFORMATION																																															
REFS	23.6890	SQ IN																																													
REFL	4.1930	IN																																													
REFB	6.5000	IN																																													
XMRP	4.9170	IN																																													
YMRP	0.0000	IN																																													
ZMRP	1.3900	IN																																													
SCALE	0.0055																																														

REFERENCE FILE

# AEDC VA 1163 MDAC BOOSTER AND ORBITER TEST DATA AT MACH NUMBER 5

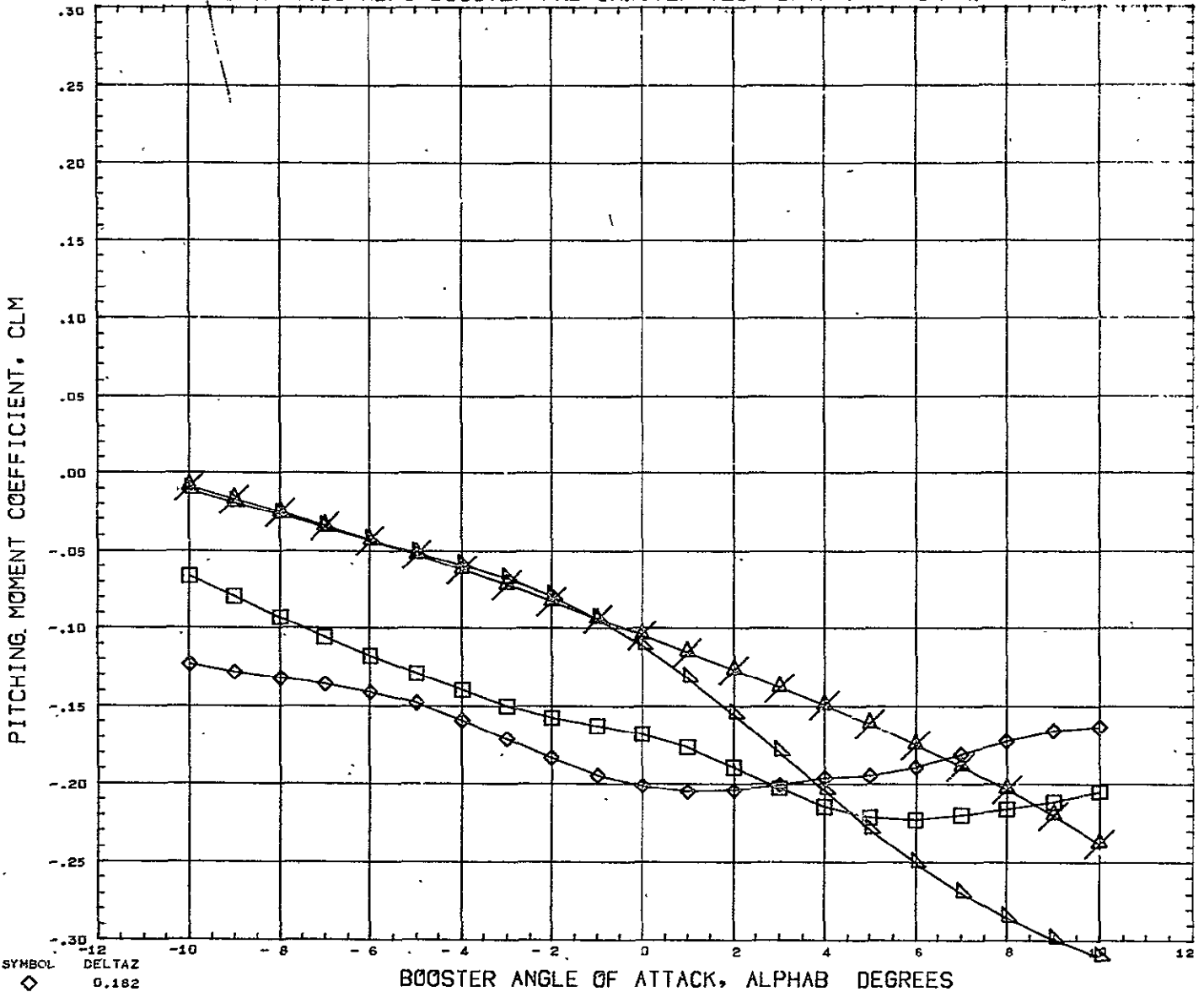

SYMBOL ◇ □ △	DELTA Z 0.182 0.228 0.352 10.000	PARAMETRIC VALUES BSTFOW 0.000 ORBPOW 0.000 DELTAX - 0.019 ALPHA1 10.100 MACH 5.010 ELVSST 0.000 ELVORB 0.000 BETA 0.000	REFERENCE INFORMATION REFS 23.6890 SQ IN REFL 4.1930 IN REFB 6.5000 IN XMRP 4.9175 IN YMRP 0.0000 IN ZMRP 1.3900 IN SCALE 0.0055
REFERENCE FILE			

# AEDC VA 1163 MDAC BOOSTER AND ORBITER TEST DATA AT MACH NUMBER 5

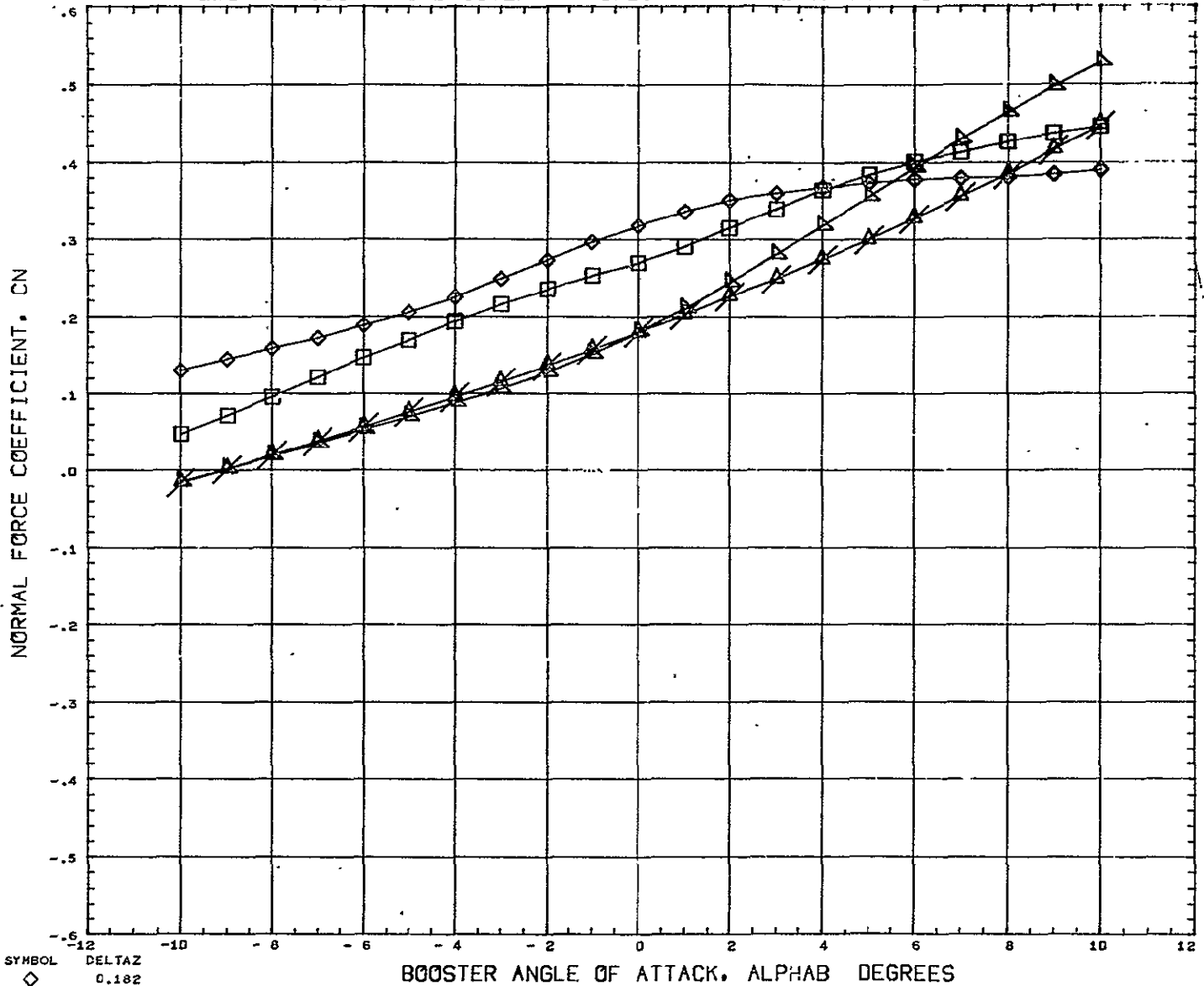

SYMBOL ◇ □ △	DELTA Z 0.182 0.228 0.352 10.000	PARAMETRIC VALUES BSTPOW 0.000 ORBPOW 0.000 CLTAX 0.019 ALPHA 10.160 MACH 5.010 ELVBST 0.000 ELVORB 0.000 BETA 0.000	REFERENCIAL INFORMATION REFS 23.6890 SQ IN REFL 4.1930 IN REFB 6.5000 IN XMRP 4.9170 IN YMRP 0.0000 IN ZMRP 1.3900 IN SCALE 0.0055
-----------------------	--	--	---

REFERENCE FILE

# AEDC VA 1163 MDAC BOOSTER AND ORBITER TEST DATA AT MACH NUMBER 5

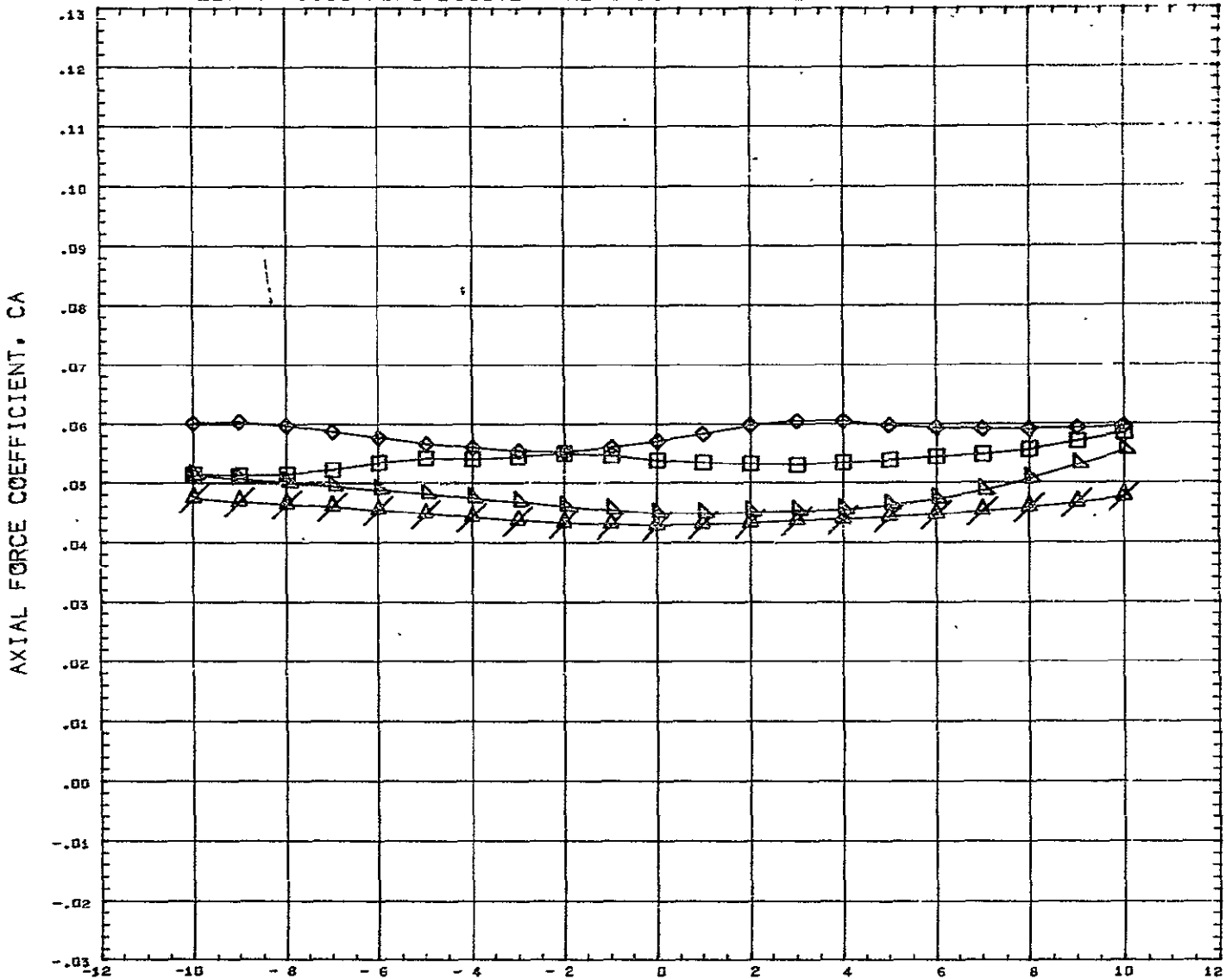

SYMBOL ◇ □ △ ▽	DELTA Z 0.162 0.228 0.352 10.000	PARAMETRIC VALUES BSTFOW 0.000    CRBPOW 0.000 DELTAX - 0.019    ALPHAI 10.100 MACH 5.010    ELVBST 0.000 ELVORB 0.000    BETA 0.000	REFERENCE INFORMATION REFS 23.6890    SQ IN REFL 4.1930    IN REFB 6.5000    IN XHRF 4.9170    IN YHRF 0.0000    IN ZHRF 1.3900    IN SCALE 0.0055
REFERENCE FILE			

# AEDC VA 1163 MDAC BOOSTER AND ORBITER TEST DATA AT MACH NUMBER 5

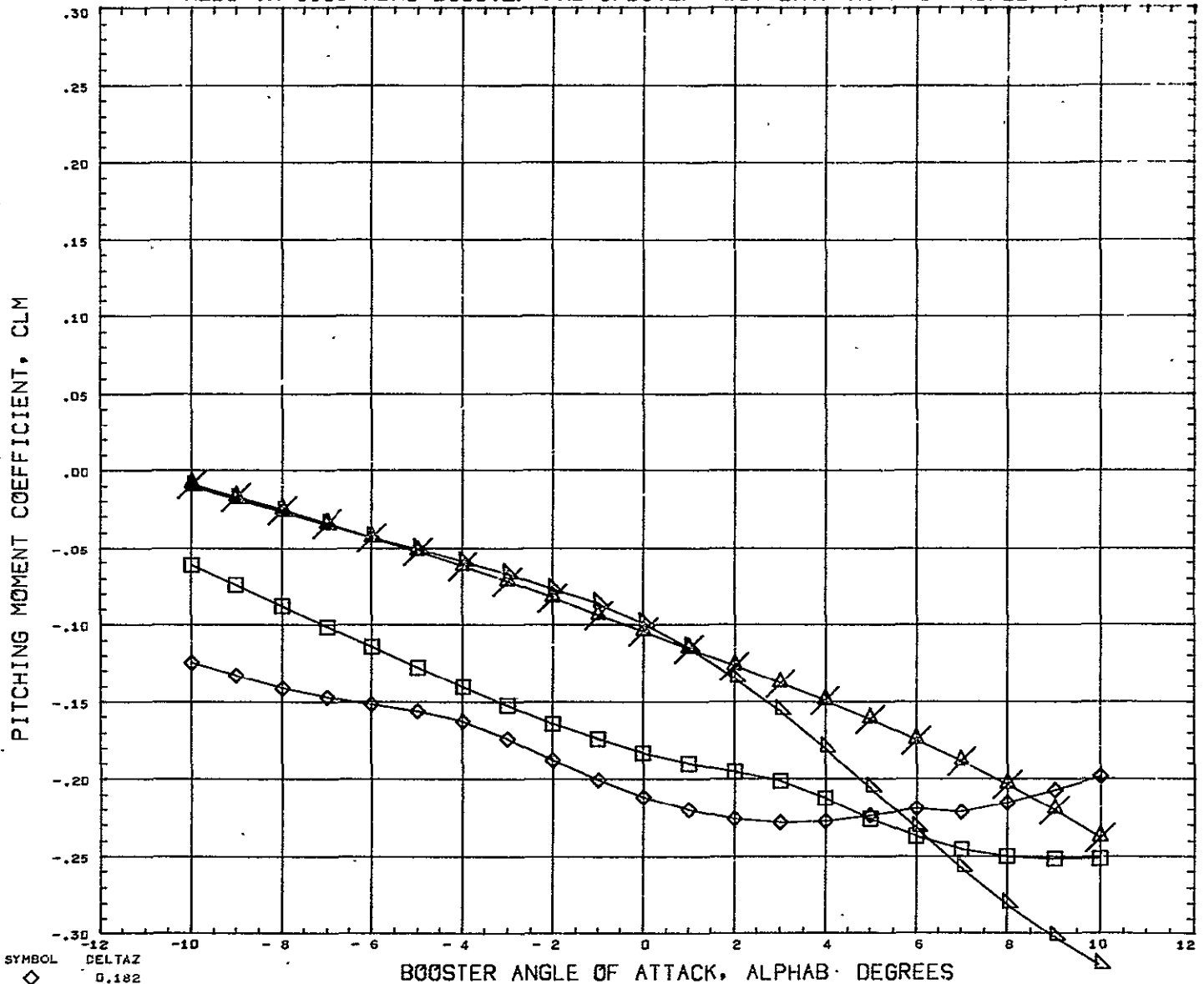

SYMBOL  $\diamond$  DELTAZ  
 $\square$  0.182  
 $\square$  0.228  
 $\triangle$  0.352  
 $\triangle$  10.000

PARAMETRIC VALUES			
B <sup>2</sup> TPOW	0.000	ORBPOW	0.000
DELTAZ	0.043	ALPHA1	10.100
MACH	5.010	ELVBST	0.000
ELVORB	0.000	BETA	0.000

REFERENCE INFORMATION		
REFS	23.6890	SQ IN
REFL	4.1930	IN
REFB	6.5000	IN
XMRP	4.9170	IN
YMRP	0.0000	IN
ZMRP	1.3900	IN
SCALE	0.0055	

REFERENCE FILE

# AEDC VA 1163 MDAC BOOSTER AND ORBITER TEST DATA AT MACH NUMBER 5

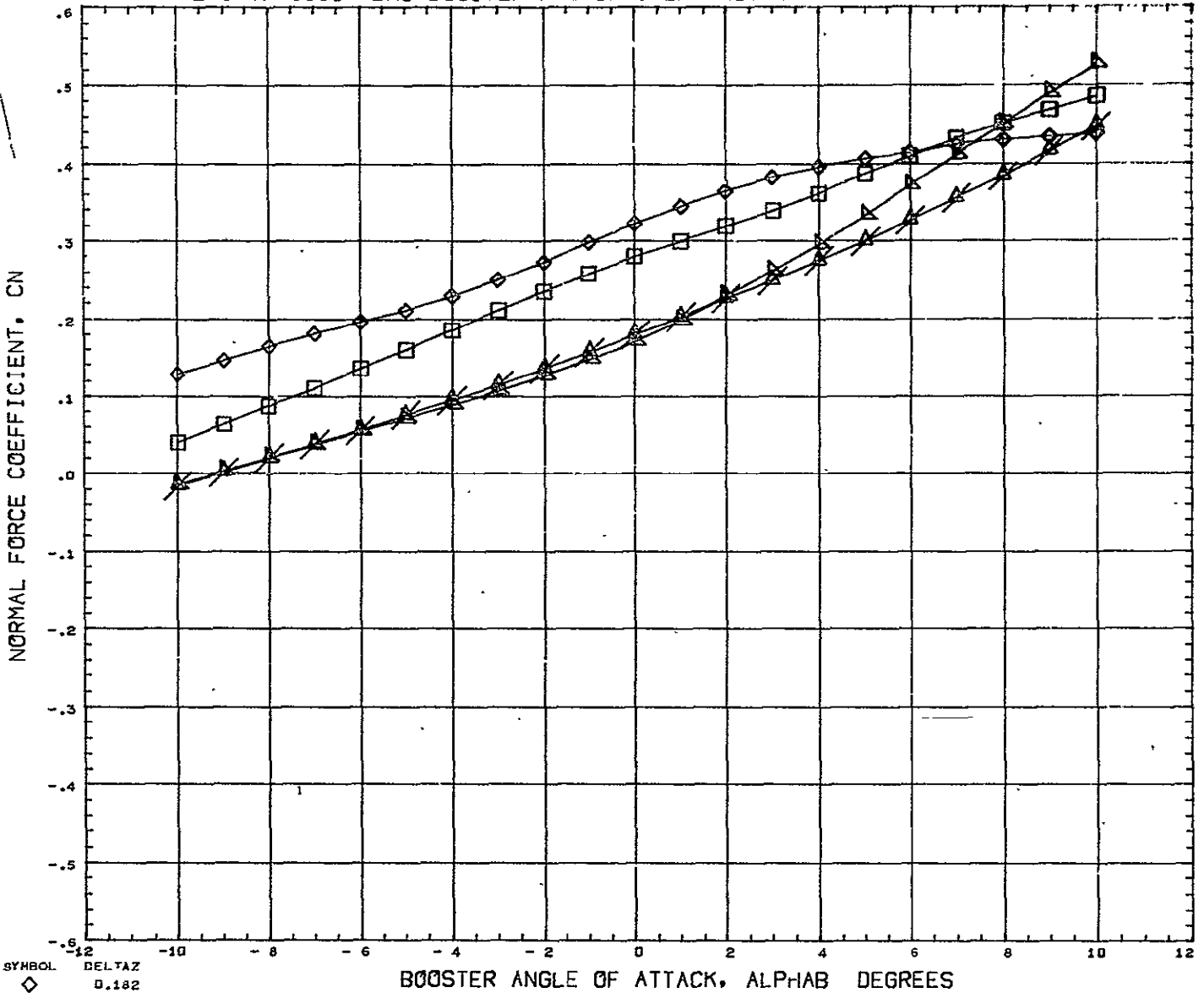

SYMBOL ◇ □ ▲	DELTAZ 0.182 0.228 0.352 10.000	PARAMETRIC VALUES BSTPOW 0.000 ORBPOW 0.000 L.LTAX 0.043 ALPHAI 10.100 MACH 5.010 ELVBST 0.000 ELVORB 0.000 BETA 0.000	REFERENCE INFORMATION REFS 23.6890 SQ IN REFL 4.1930 IN REFB 6.5000 IN XMRP 4.9175 IN YMRP 0.0000 IN ZMRP 1.3900 IN SCALE 0.0055
REFERENCE FILE			

# AEDC VA 1163 MDAC BOOSTER AND ORBITER TEST DATA AT MACH NUMBER 5

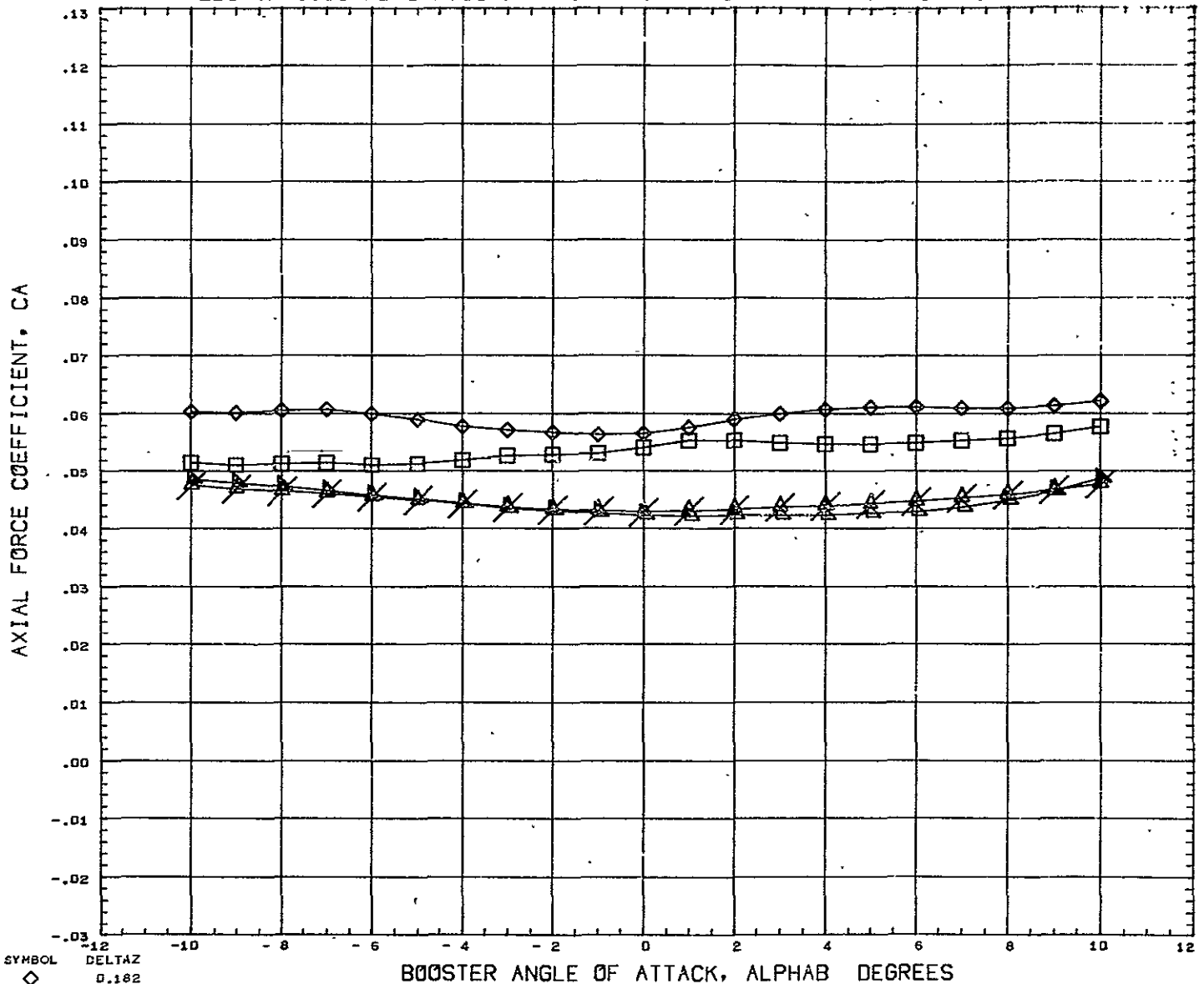

SYMBOL ◇ □ △	DELTAZ 0.182 0.228 0.352 10.500	PARAMETRIC VALUES BSTPOW 0.000 ORBPOW 0.000 DELTAX 0.043 ALPHAI 10.100 MACH 5.010 ELVBST 0.000 ELVORB 0.000 BETA 0.000	REFERENCE INFORMATION REFS 23.6890 SQ IN REFL 4.1930 IN REFB 6.5000 IN XMRP 4.9170 IN YMRP 0.0000 IN ZHRP 1.3900 IN SCALE 0.0055
-----------------------	---	--	---

REFERENCE FILE



# AEDC VA 1163 MDAC BOOSTER AND ORBITER TEST DATA AT MACH NUMBER 5

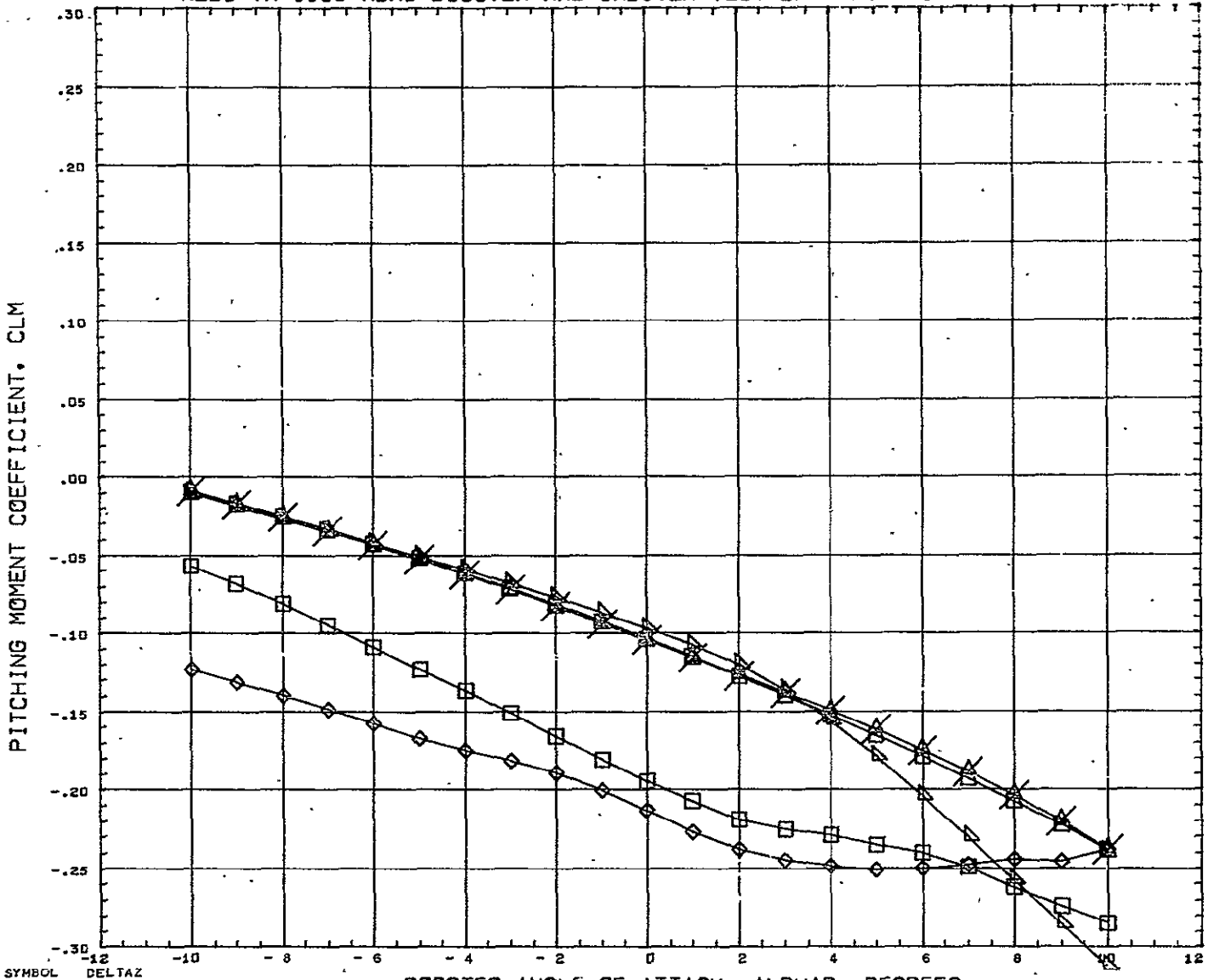

SYMBOL ◇ □ △	DELTA Z 0.182 0.228 0.352 0.599 10.000	PARAMETRIC VALUES P*TPOW 0.000 ORBPOW 0.000 DELTAX 0.105 ALPHAI 10.100 MACH 5.010 ELVBST 0.000 ELVORB 0.000 BETA 0.000	REFERENCE INFORMATION REFS 23.6895 SQ IN REFL 4.1930 IN REFB 6.5000 IN XMRF 4.9170 IN YMRF 0.0000 IN ZMRF 1.3900 IN SCALE 0.0055
-----------------------	---	--	---

REFERENCE FILE

# AEDC VA 1163 MDAC BOOSTER AND ORBITER TEST DATA AT MACH NUMBER 5

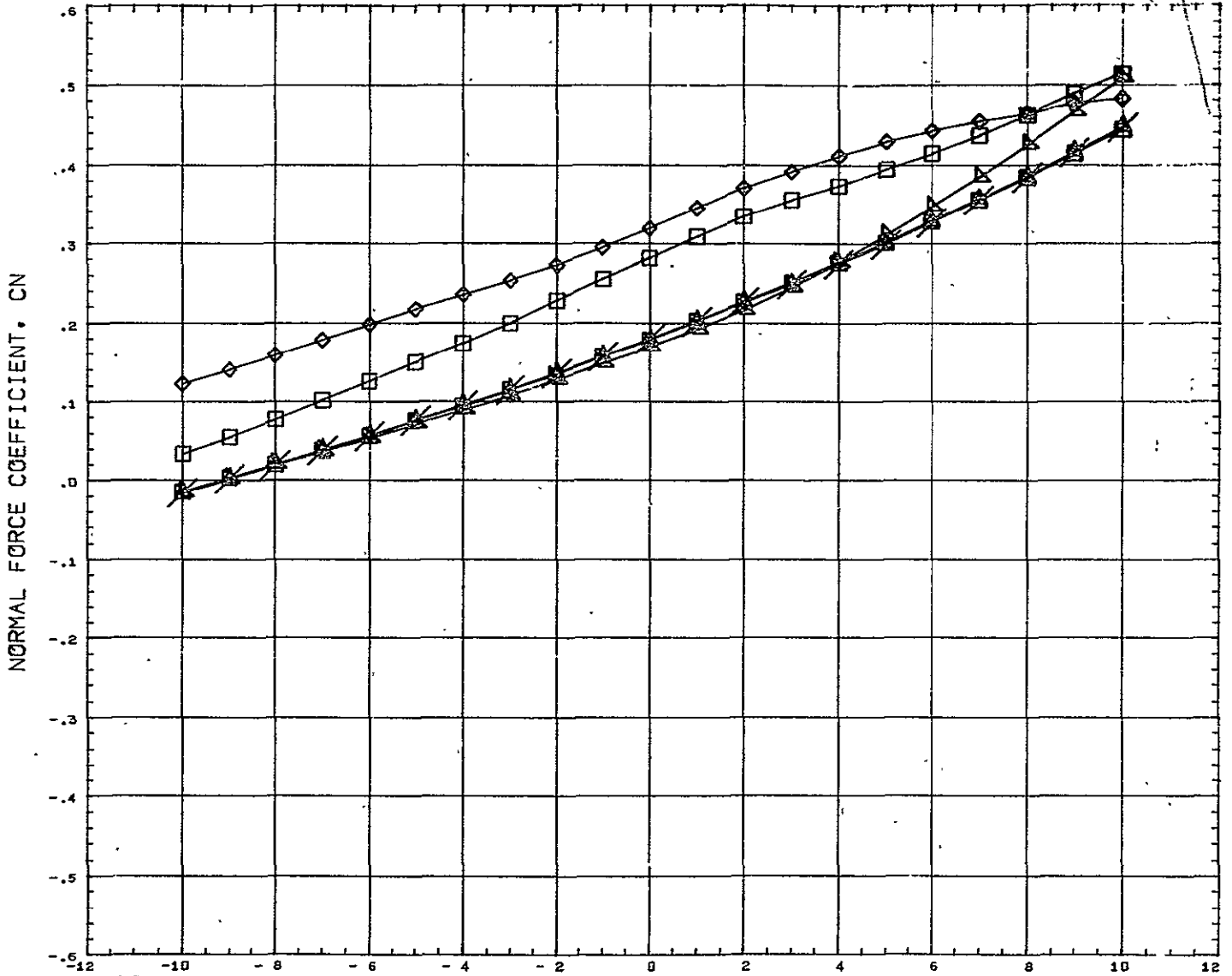

SYMBOL	DELTA Z 0.182 0.228 0.352 0.599 10.000	PARAMETRIC VALUES E.TPOW    0.000    ORBPOW    0.000 DELTAX    0.105    ALPHAI    10.100 MACH       5.010    ELVBST    0.000 ELVORB    0.000    BETA       0.000	REFERENCE INFORMATION REFS       23.6890    SQ IN REFL       4.1930    IN REFB       6.5000    IN XMRF       4.9170    IN YMRP       0.0000    IN ZMRP       1.3900    IN SCALE      0.0055
REFERENCE FILE			

# AEDC VA 1163 MDAC BOOSTER AND ORBITER TEST DATA AT MACH NUMBER 5

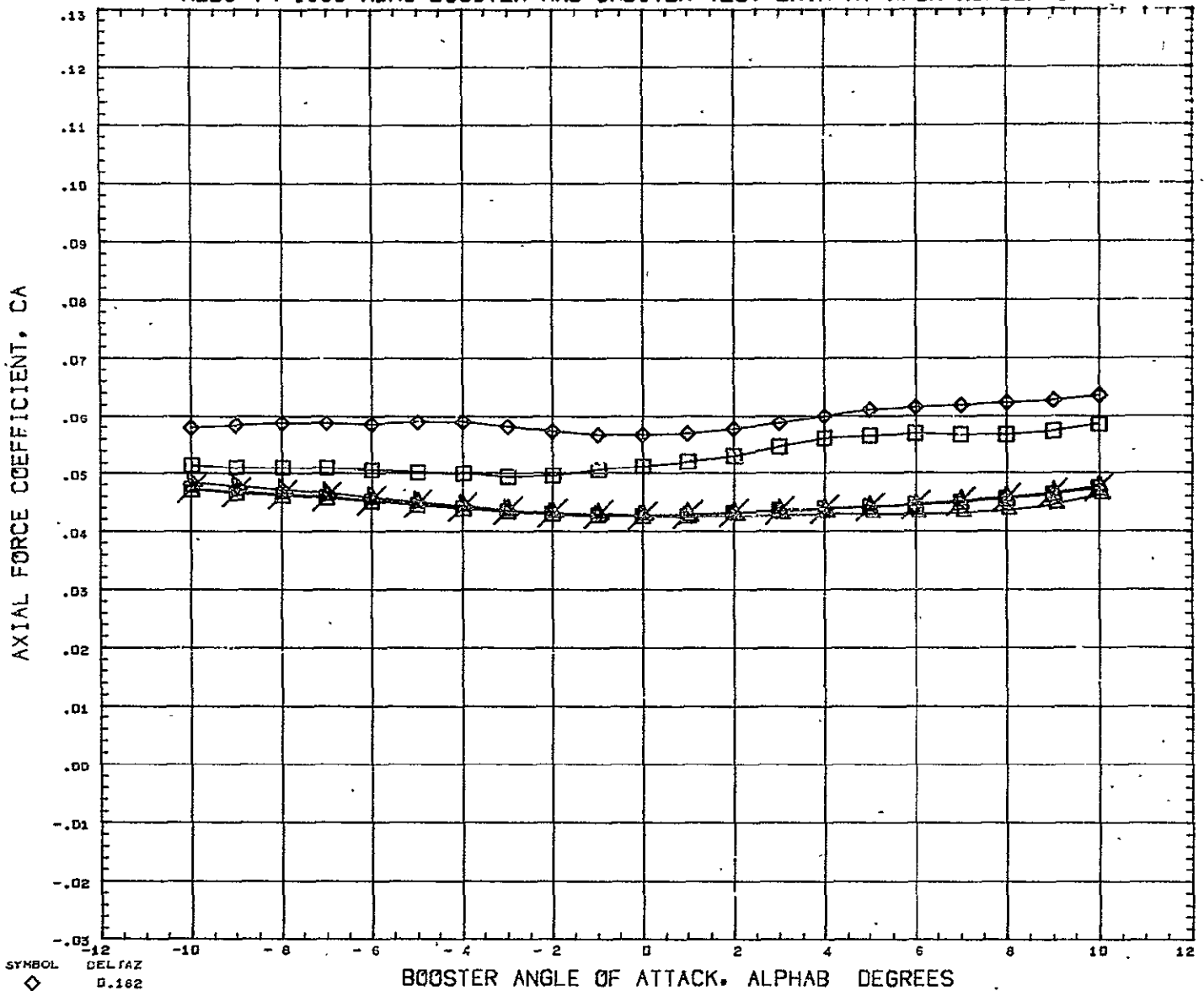

SYMBOL ◇ □ △	DELTAZ 0.182 0.228 0.352 0.599 10.660	PARAMETRIC VALUES RSTPOW 0.000 ORBPOW 0.000 DELTAX 0.105 ALPHAI 10.100 MACH 5.010 ELVBST 0.000 ELVORB 0.000 BETA 0.000	REFERENCE INFORMATION REFS 23.6890 SQ IN REFL 4.1930 IN REFB 6.5000 IN XMRP 4.9170 IN YMRP 0.0000 IN ZMRP 1.3900 IN SCALE 0.0055
-----------------------	--	--	---

REFERENCE FILE

# AEDC VA 1163 MDAC BOOSTER AND ORBITER TEST DATA AT MACH NUMBER 5

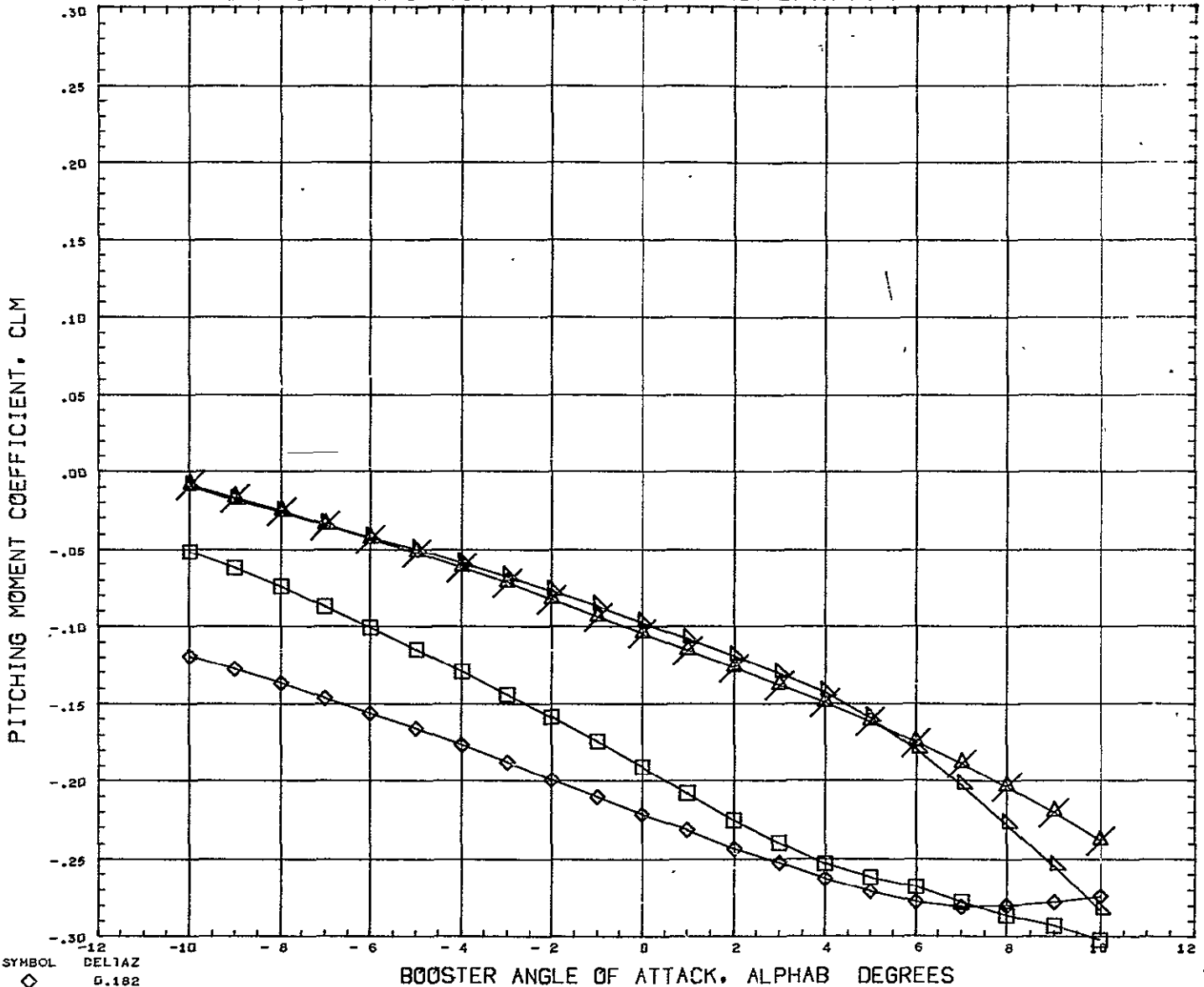

SYMBOL ◇ □ △	DELTAZ 0.182 0.228 0.352 10.000	PARAMETRIC VALUES BSTPOW    0.000    ORBPOW    0.000 DELTAX    0.167    ALPHA1    10.100 MACH       5.010    ELVBST    0.000 ELVORB    0.000    BETA       0.000	REFERENCE INFORMATION REFS       23.6890    SQ IN REFL       4.1930    IN REFB       6.5000    IN XMRF       4.9170    IN YMRF       0.0000    IN ZMRF       1.3900    IN SCALE      0.0055
-----------------------	---	--	--

REFERENCE FILE

# AEDC VA 1163 MDAC BOOSTER AND ORBITER TEST DATA AT MACH NUMBER 5

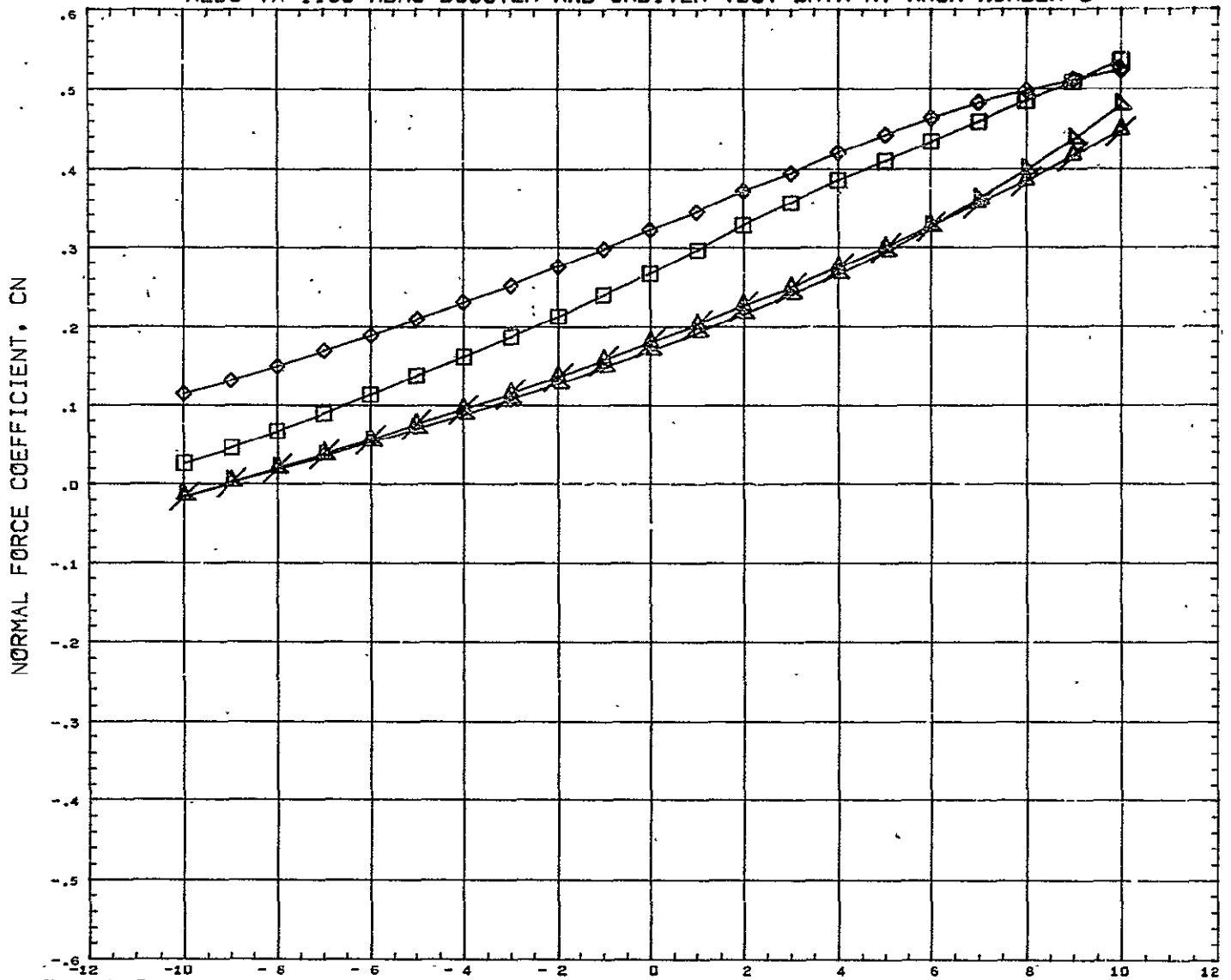

SYMBOL ◇ □ ▲	DELTA Z 0.182 0.228 0.352 10.000	PARAMETRIC VALUES BSTPOW 0.000 ORBPOW 0.000 CLTAX 0.167 ALPHAI 10.100 MACH 5.010 ELVBST 0.000 ELVORB 0.000 BETA 0.000	REFERENCE INFORMATION REFS 23.6890 SQ IN REFL 4.1930 IN REFB 6.5000 IN XMRP 4.9170 IN YMRP 0.0000 IN ZMRP 1.3900 IN SCALE 0.0055
REFERENCE FILE			

# AEDC VA 1163 MDAC BOOSTER AND ORBITER TEST DATA AT MACH NUMBER 5

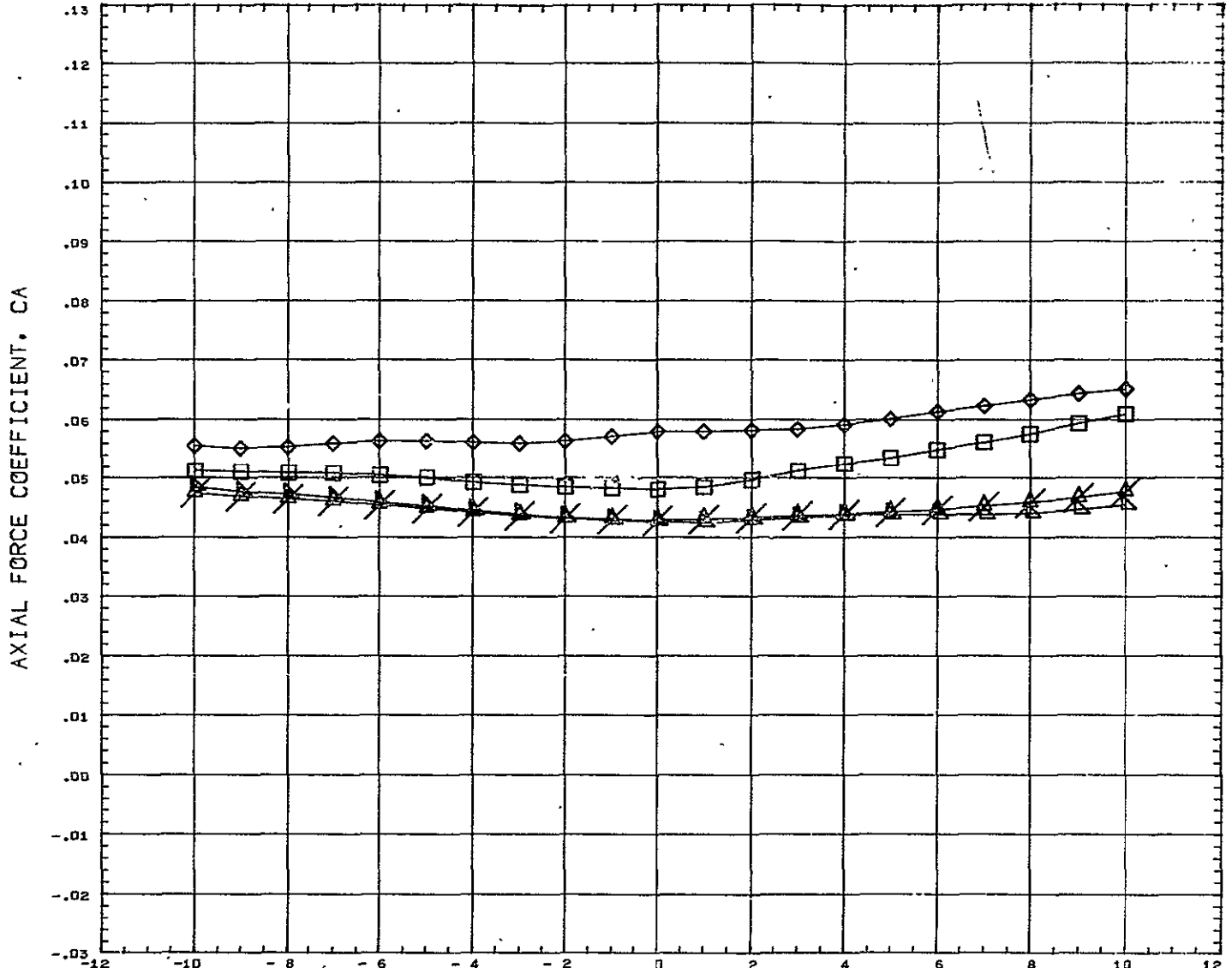

SYMBOL ◇ □ △	DELTAZ 0.102 0.228 0.352 10.000	PARAMETRIC VALUES	ORBPOW 0.000 ALPHAI 10.100 ELVBST 0.000 BETA 0.000	REFERENCE INFORMATION	REFS 23.6890 SQ IN REFL 4.1930 IN REFB 6.5000 IN XMRF 4.9170 IN YMRF 0.0000 IN ZMRF 1.3900 IN SCALE 0.0055
-----------------------	---	-------------------	---	-----------------------	--

REFERENCE FILE

# AEDC VA 1163 MDAC BOOSTER AND ORBITER TEST DATA AT MACH NUMBER 5

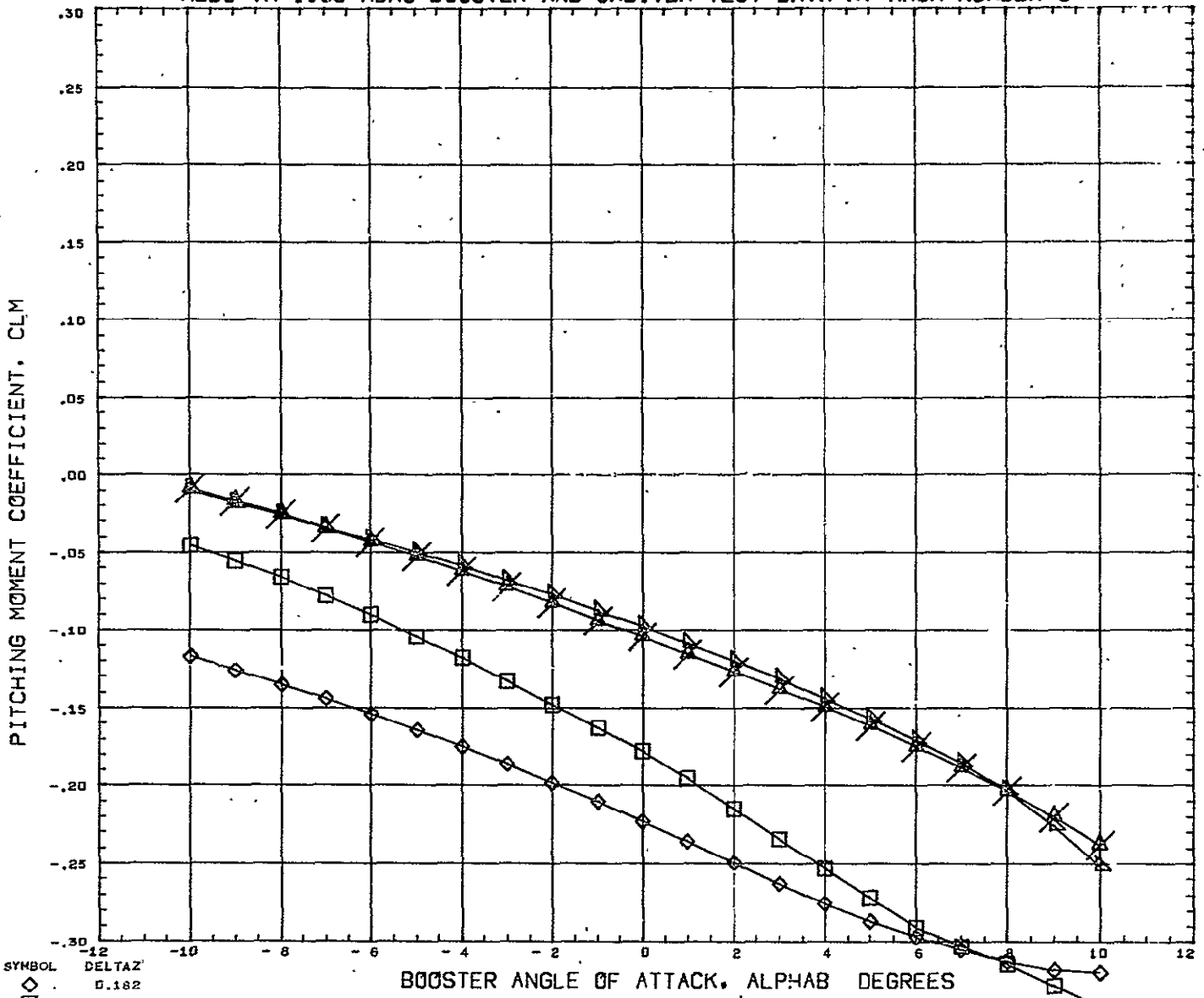

SYMBOL ◇ □ △	DELTA Z' 0.182 0.228 0.352 10.000	PARAMETRIC VALUES BSTFOW 0.000 ORBPOW 0.000 DELTAX 0.228 ALPHA1 10.100 MACH 5.010 ELVBST 0.000 ELVORB 0.000 BETA 0.000	REFERENCE INFORMATION REFS 23.6890 SQ IN REFL 4.1950 IN REFB 6.5000 IN XMRF 4.9170 IN YMRF 0.0000 IN ZMRF 1.3900 IN SCALE 0.0055
-----------------------	---	--	---

REFERENCE FILE

# AEDC VA 1163 MDAC BOOSTER AND ORBITER TEST DATA AT MACH NUMBER 5

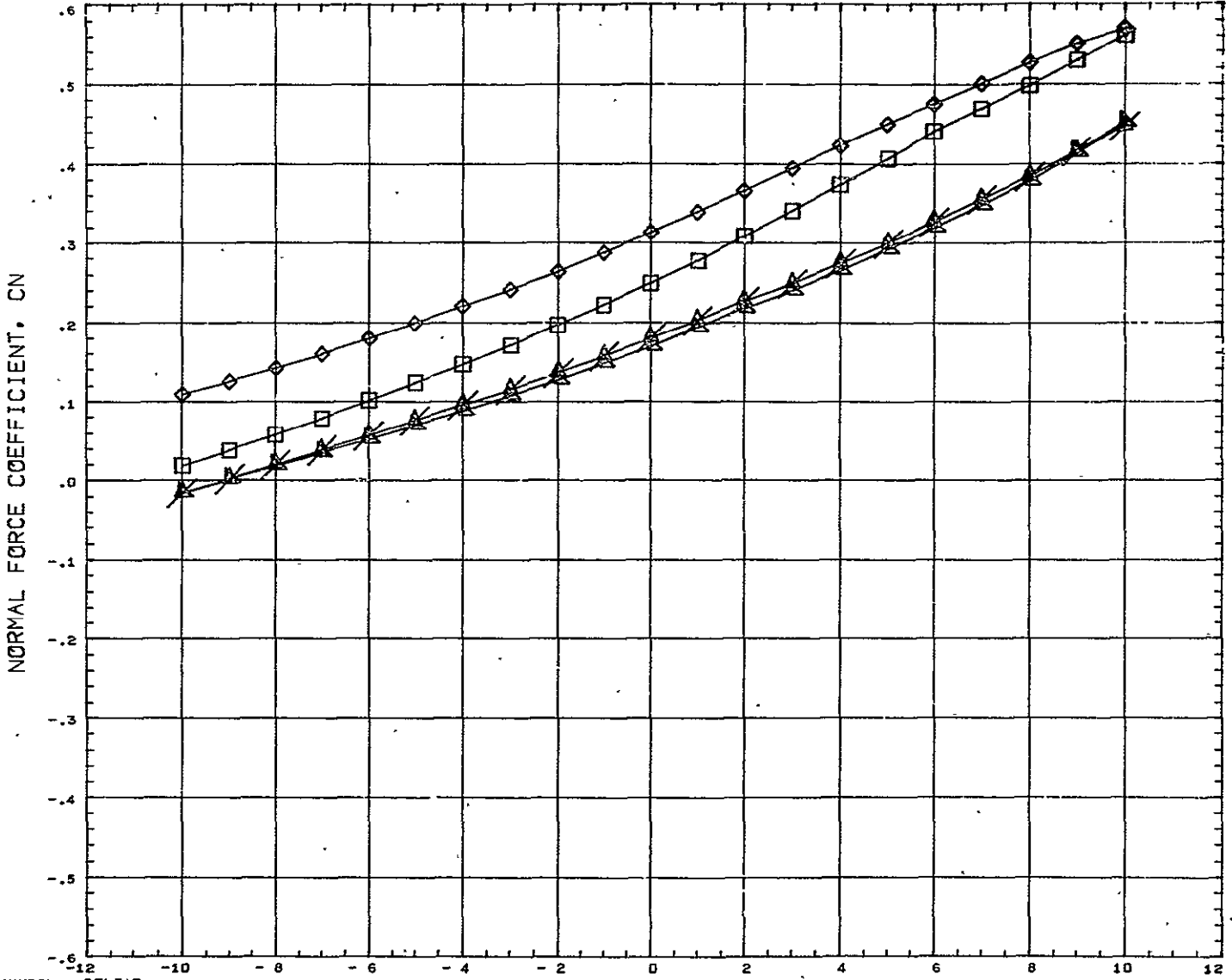

SYMBOL ◇ □ ▲	DELTA Z 0.182 0.228 0.352 10.000	PARAMETRIC VALUES BSTPCW    0.000    ORBPCW    0.000 DELTAX    0.228    ALPHA1    10.100 MACH       5.010    ELVBST    0.000 ELVORB    0.000    BETA       0.000	REFERENCE INFORMATION REFS       23.6890    SQ IN REFL       4.1930    IN REFB       6.5000    IN XMRP       4.9170    IN YMRP       0.0000    IN ZMRP       1.3900    IN SCALE      0.0055
-----------------------	--	--	--

REFERENCE FILE



# AEDC VA 1163 MDAC BOOSTER AND ORBITER TEST DATA AT MACH NUMBER 5

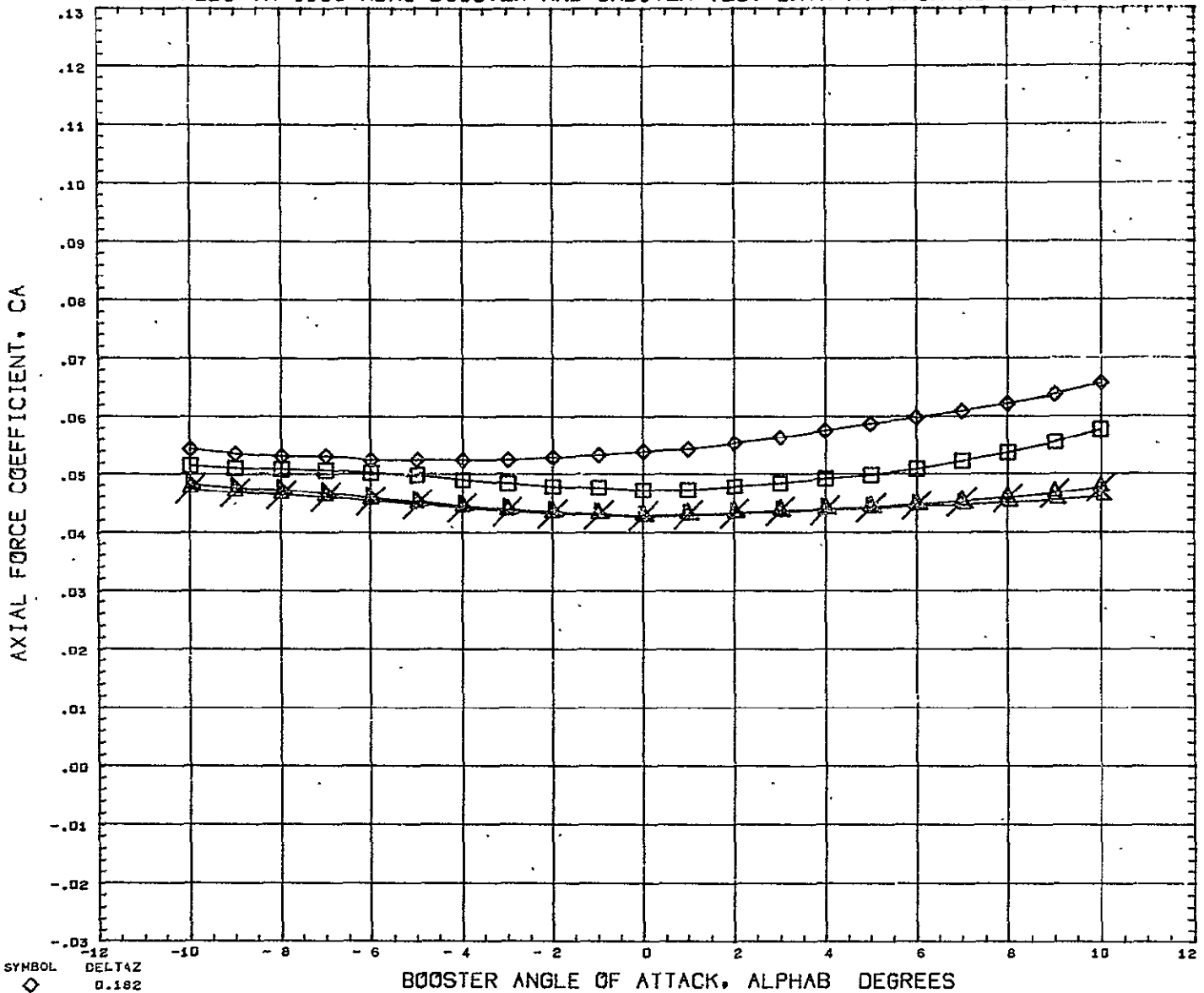

SYMBOL 	DELTA Z 0.182 0.228 0.352 10.000	PARAMETRIC VALUES	CRBPOW 0.000 ALPHAI 10.100 ELVBST 0.000 BETA 0.000	REFERENCE INFORMATION	REFS 23.6890 SQ IN REFL 4.1930 IN REFB 6.5000 IN XMRF 4.917C IN YMRF 0.0000 IN ZMRF 1.3900 IN SCALE 0.0055
------------	--	-------------------	---	-----------------------	--

REFERENCE FILE

# AEDC VA 1163 MDAC BOOSTER AND ORBITER TEST DATA AT MACH NUMBER 5

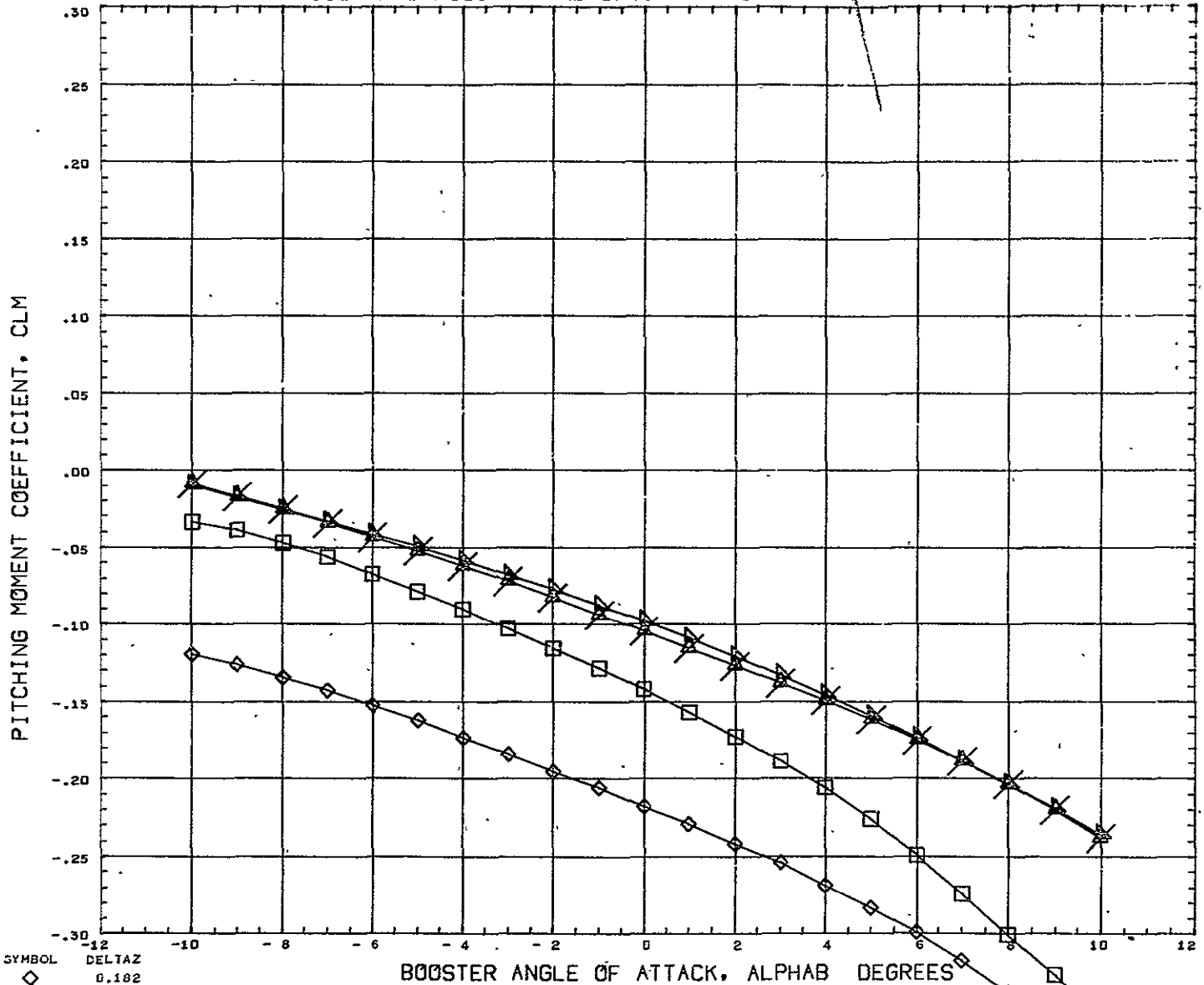

SYMBOL ◇ □ △	DELTAX 0.182 0.228 0.352 10.000	PARAMETRIC VALUES BSTFOW 0.000 DELTAX 0.352 MACH 5.010 ELVORB 0.000 ORBPOW 0.000 ALPHAI 10.100 ELVBST 0.000 BETA 0.000	REFERENCE INFORMATION REFS 23.6890 REFL 4.1500 REFB 6.5000 XMRF 4.9170 YMRF 0.0000 ZMRF 1.3900 SCALE 0.0055 SQ IN IN IN IN IN IN
-----------------------	---	--	---

REFERENCE FILE

# AEDC VA 1163 MDAC BOOSTER AND ORBITER TEST DATA AT MACH NUMBER 5

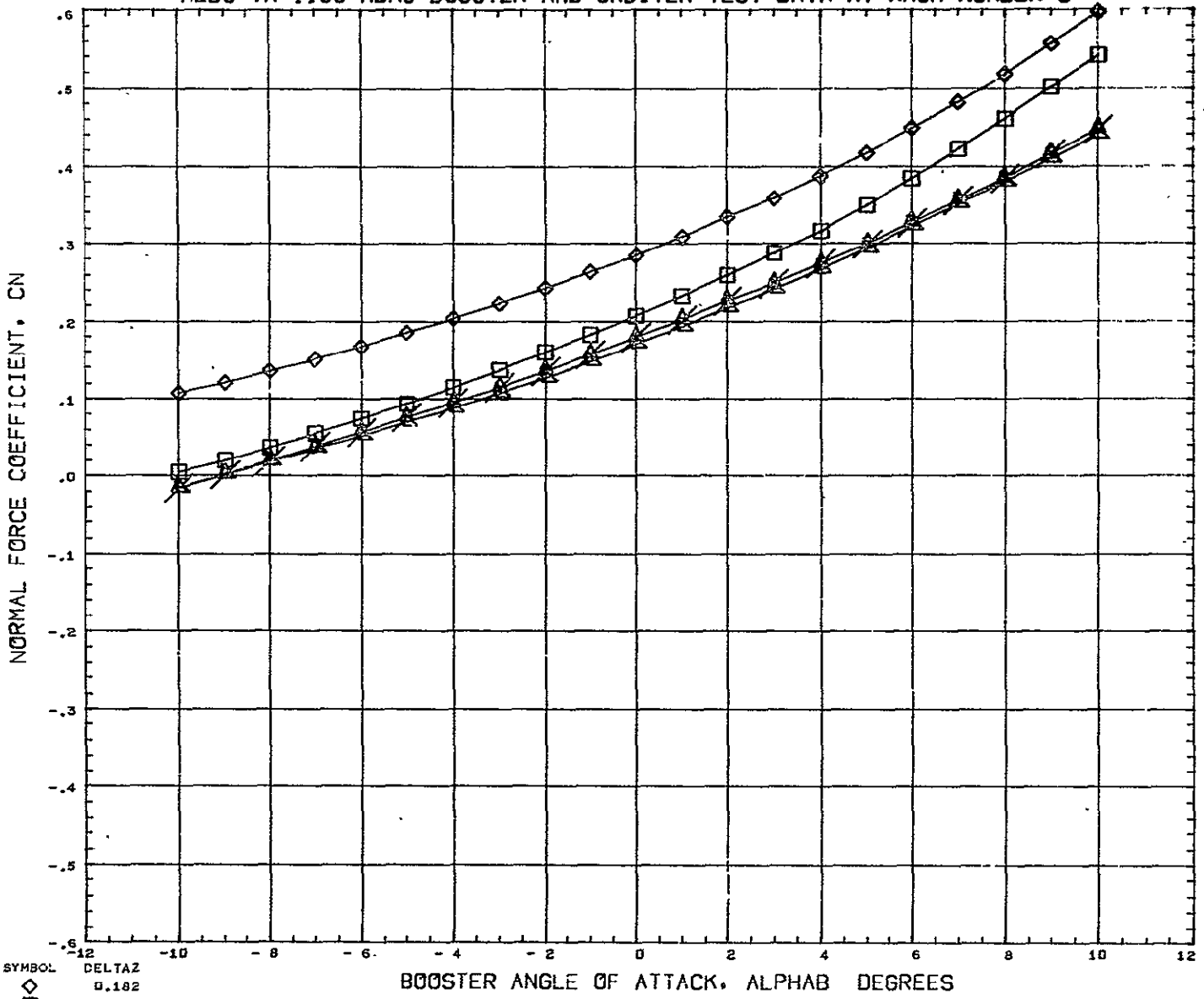

SYMBOL ◇ □ ▲	DELTAZ 0.182 0.228 0.352 10.000	<table border="0" style="width: 100%;"> <tr> <th colspan="4" style="text-align: left;">PARAMETRIC VALUES</th> </tr> <tr> <td style="width: 25%;">RSTPOW</td> <td style="width: 25%;">0.000</td> <td style="width: 25%;">ORBPOW</td> <td style="width: 25%;">0.000</td> </tr> <tr> <td>DELTA X</td> <td>0.352</td> <td>ALPHA I</td> <td>10.100</td> </tr> <tr> <td>MACH</td> <td>5.010</td> <td>ELVBST</td> <td>0.000</td> </tr> <tr> <td>ELVORB</td> <td>0.000</td> <td>BETA</td> <td>0.000</td> </tr> </table>	PARAMETRIC VALUES				RSTPOW	0.000	ORBPOW	0.000	DELTA X	0.352	ALPHA I	10.100	MACH	5.010	ELVBST	0.000	ELVORB	0.000	BETA	0.000	<table border="0" style="width: 100%;"> <tr> <th colspan="3" style="text-align: left;">REFERENCE INFORMATION</th> </tr> <tr> <td style="width: 33%;">REPS</td> <td style="width: 33%;">23.6890</td> <td style="width: 33%;">SQ IN</td> </tr> <tr> <td>REFL</td> <td>4.1930</td> <td>IN</td> </tr> <tr> <td>REFB</td> <td>6.5000</td> <td>IN</td> </tr> <tr> <td>XMRP</td> <td>4.917C</td> <td>IN</td> </tr> <tr> <td>YMRP</td> <td>0.0000</td> <td>IN</td> </tr> <tr> <td>ZMRP</td> <td>1.3900</td> <td>IN</td> </tr> <tr> <td>SCALE</td> <td>0.0055</td> <td></td> </tr> </table>	REFERENCE INFORMATION			REPS	23.6890	SQ IN	REFL	4.1930	IN	REFB	6.5000	IN	XMRP	4.917C	IN	YMRP	0.0000	IN	ZMRP	1.3900	IN	SCALE	0.0055	
PARAMETRIC VALUES																																															
RSTPOW	0.000	ORBPOW	0.000																																												
DELTA X	0.352	ALPHA I	10.100																																												
MACH	5.010	ELVBST	0.000																																												
ELVORB	0.000	BETA	0.000																																												
REFERENCE INFORMATION																																															
REPS	23.6890	SQ IN																																													
REFL	4.1930	IN																																													
REFB	6.5000	IN																																													
XMRP	4.917C	IN																																													
YMRP	0.0000	IN																																													
ZMRP	1.3900	IN																																													
SCALE	0.0055																																														

REFERENCE FILE

# AEDC VA 1163 MDAC BOOSTER AND ORBITER TEST DATA AT MACH NUMBER 5

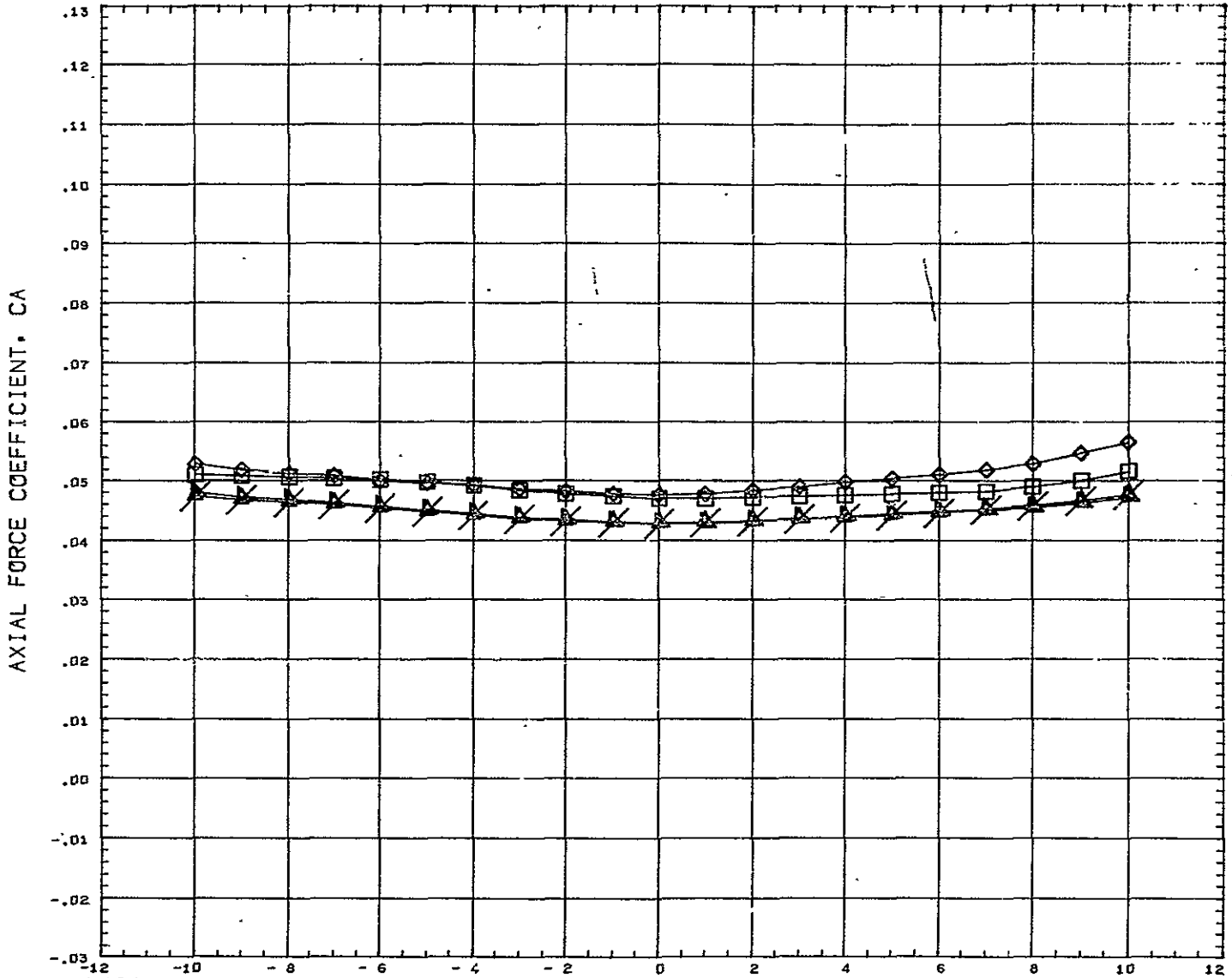

SYMBOL 	DELTAZ 0.102 0.228 0.352 10.000	<b>PARAMETRIC VALUES</b> PSTFOW    0.000    ORBFOW    0.000 DELTAX    0.352    ALPHAI    10.100 MACH      5.010    ELVBST    0.000 ELVORB    0.000    BETA      0.000	<b>REFERENCE INFORMATION</b> REFS      23.6890    SQ IN REFL      4.1930    IN REFB      6.5000    IN XMRP      4.9170    IN YMRP      0.0000    IN ZMRP      1.3900    IN SCALE     0.0055
REFERENCE FILE			

# AEDC VA 1163 MDAC BOOSTER AND ORBITER TEST DATA AT MACH NUMBER 5

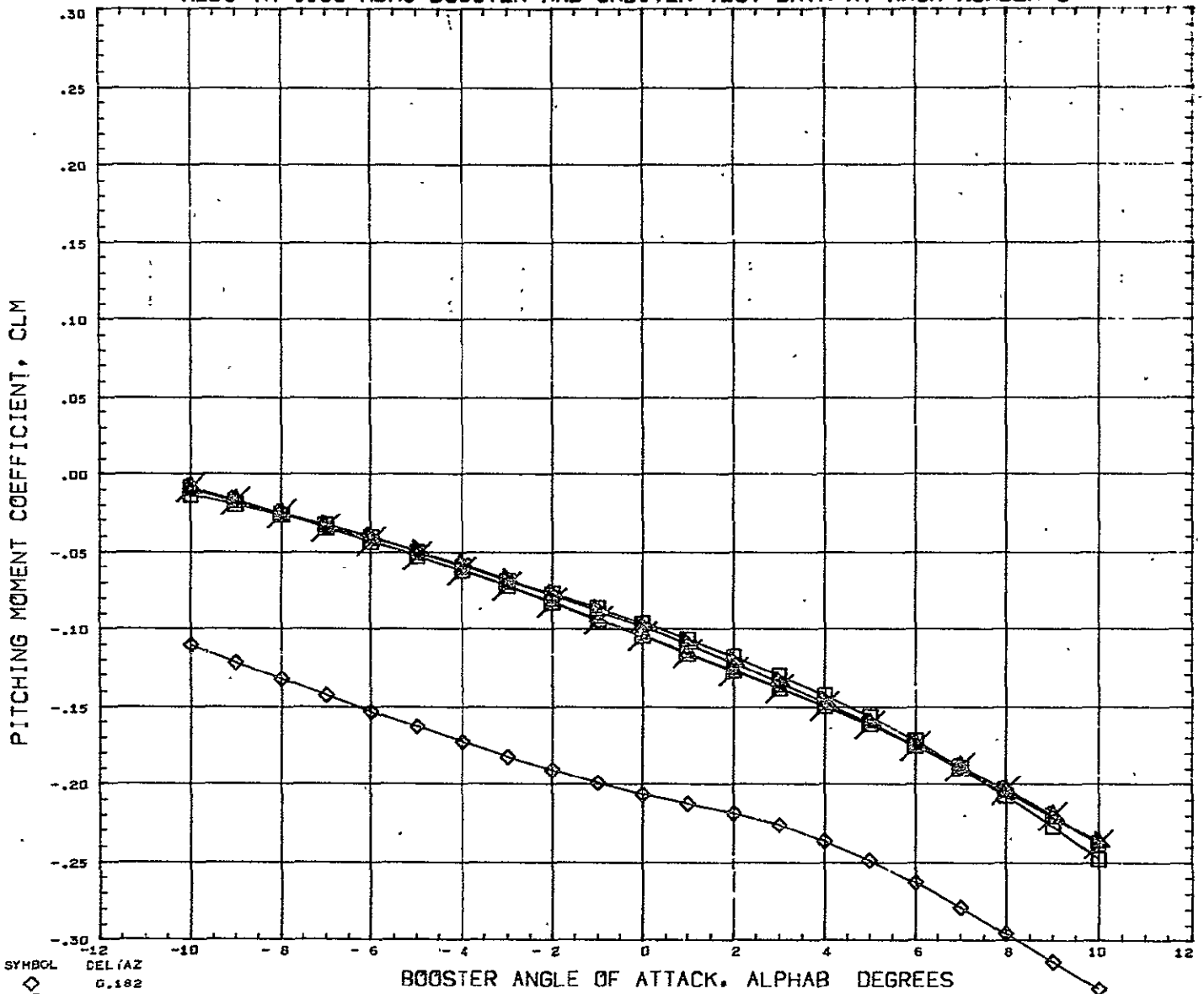

SYMBOL ◇ □ ◻ ◻	DELTA Z 0.182 0.228 0.352 0.599 10.000  B9FOW 0.000 DELTAX 0.501 MACH 5.010 ELVORB 0.000	PARAMETRIC VALUES ORB FOW 0.000 ALPHA 10.100 ELV BST 0.000 BETA 0.000	REFERENCE INFORMATION REFS 23.6890 REFL 4.1930 REFB 6.5000 XHRF 4.9170 YHRF 0.0000 ZHRF 1.3900 SCALE 0.0055	SQ IN IN IN IN IN IN
----------------------------	--	---	--	-------------------------------------

REFERENCE FILE

# AEDC VA 1163 MDAC BOOSTER AND ORBITER TEST DATA AT MACH NUMBER 5

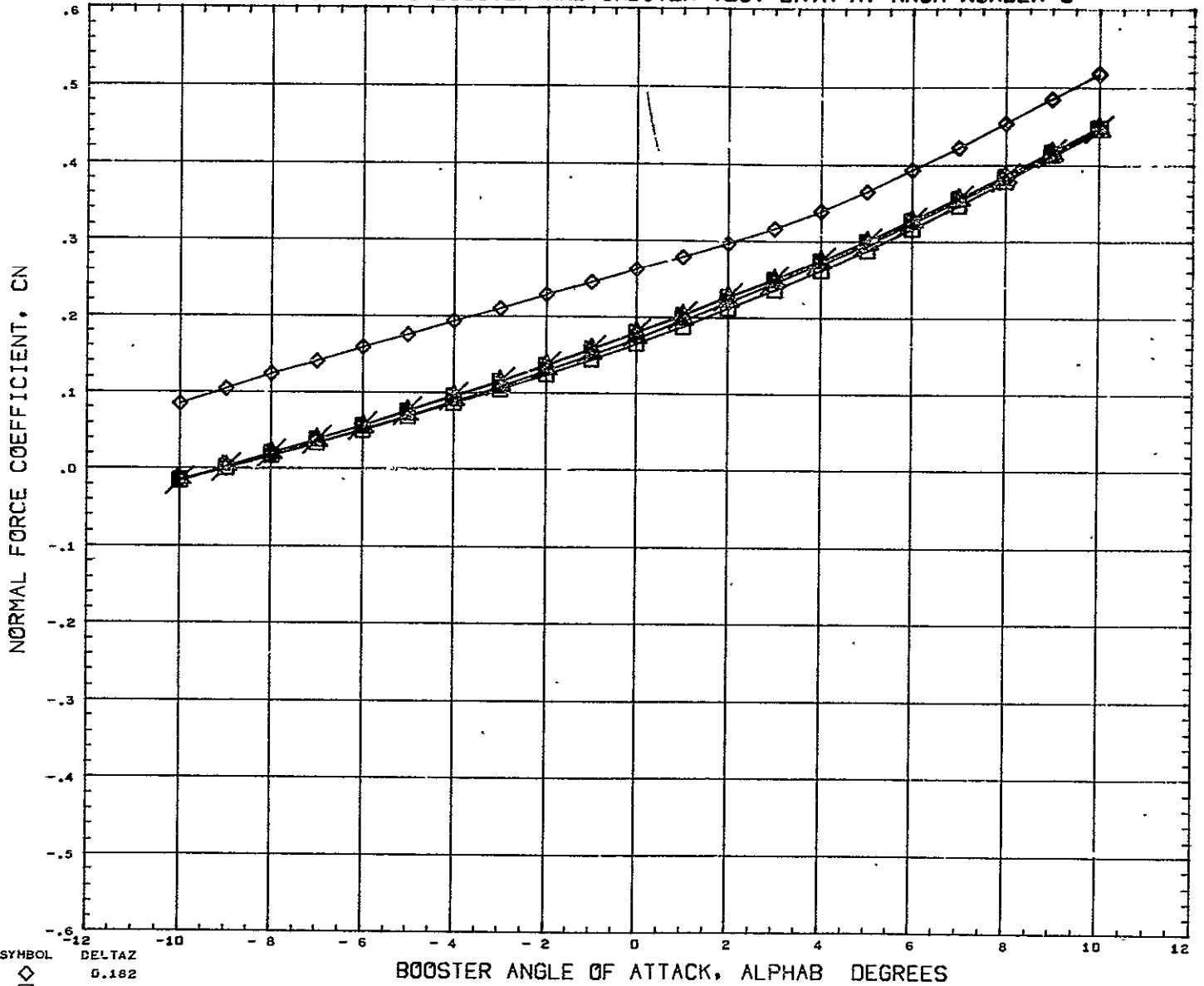

SYMBOL  
 ◇ 0.182  
 □ 0.228  
 △ 0.352  
 × 0.599  
 10.000

PARAMETRIC VALUES  
 BSTPOW 0.000 ORBPOW 0.000  
 DELTAX 0.501 ALPHAI 10.100  
 MACH 5.010 ELVBST 0.000  
 ELVORB 0.000 BETA 0.000

REFERENCE INFORMATION  
 REFS 23.6890 SQ IN  
 REFL 4.1930 IN  
 REFB 6.5000 IN  
 XMRP 4.9170 IN  
 YMRP 0.0000 IN  
 ZMRP 1.3900 IN  
 SCALE 0.0055

REFERENCE FILE

# AEDC VA 1163 MDAC BOOSTER AND ORBITER TEST DATA AT MACH NUMBER 5

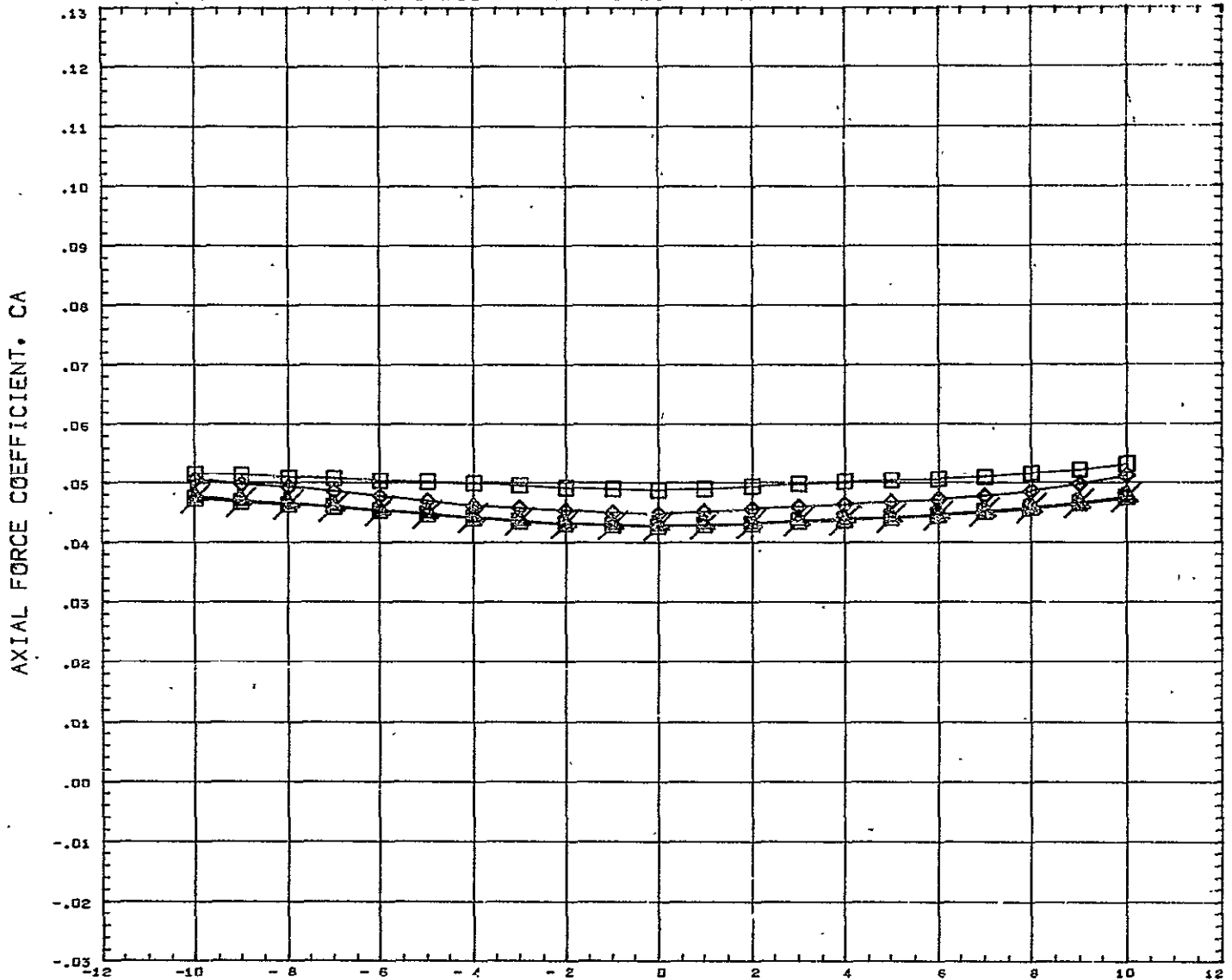

SYMBOL ◇ □ △ ×	DELTA Z 0.182 0.228 0.352 0.599 10.000	PARAMETRIC VALUES BSTPOW 0.000 ORBPOW 0.000 LELTAX 0.501 ALPHAI 10.100 MACH 5.010 ELVBST 0.000 ELVORB 0.000 BETA 0.000	REFERENCE INFORMATION REFS 23.689D SQ IN REFL 4.193D IN REFB 6.500D IN XMRP 4.917D IN YMRP 0.000D IN ZMRP 1.390D IN SCALE 0.0055
----------------------------	---	--	---

REFERENCE FILE

# AEDC VA 1163 MDAC BOOSTER AND ORBITER TEST DATA AT MACH NUMBER 5

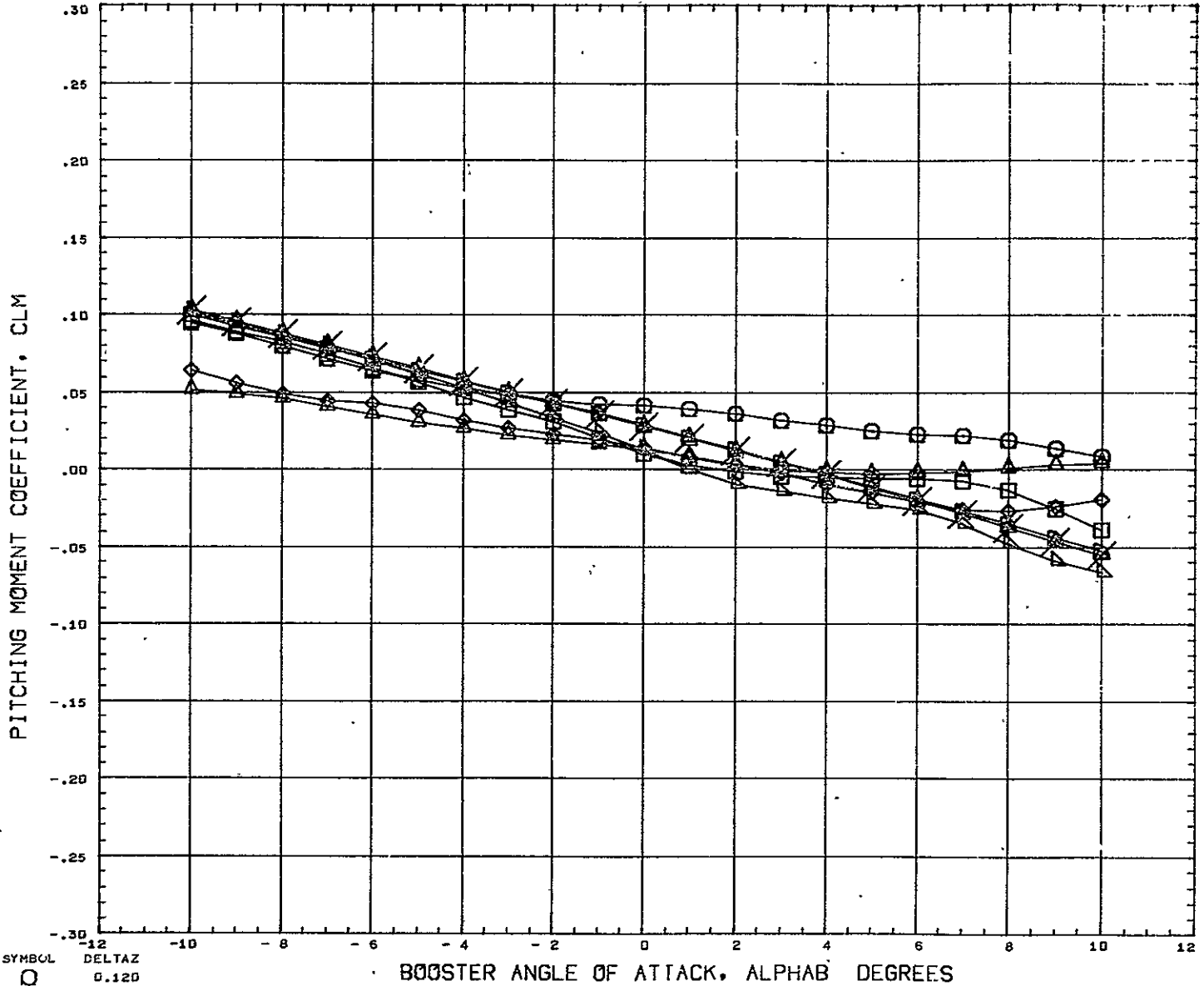

SYMBOL ○ □ △ ◇ ×	DELTAZ 0.120 0.151 0.182 0.228 0.352 0.599 10.000	PARAMETRIC VALUES 3STPOW 0.000 ORBPOW 0.000 DELTAX - 0.391 ALPHAI - 4.900 MACH 5.010 ELVBST 0.000 ELVORB 0.000 BETA 0.000	REFERENCE INFORMATION REFS 23.6890 SQ IN REFL 4.1930 IN REFB 6.5000 IN XMRF 4.9170 IN YMRF 0.0000 IN ZMRF 1.3900 IN SCALE 0.0055
REFERENCE FILE			



# AEDC VA 1163 MDAC BOOSTER AND ORBITER TEST DATA AT MACH NUMBER 5

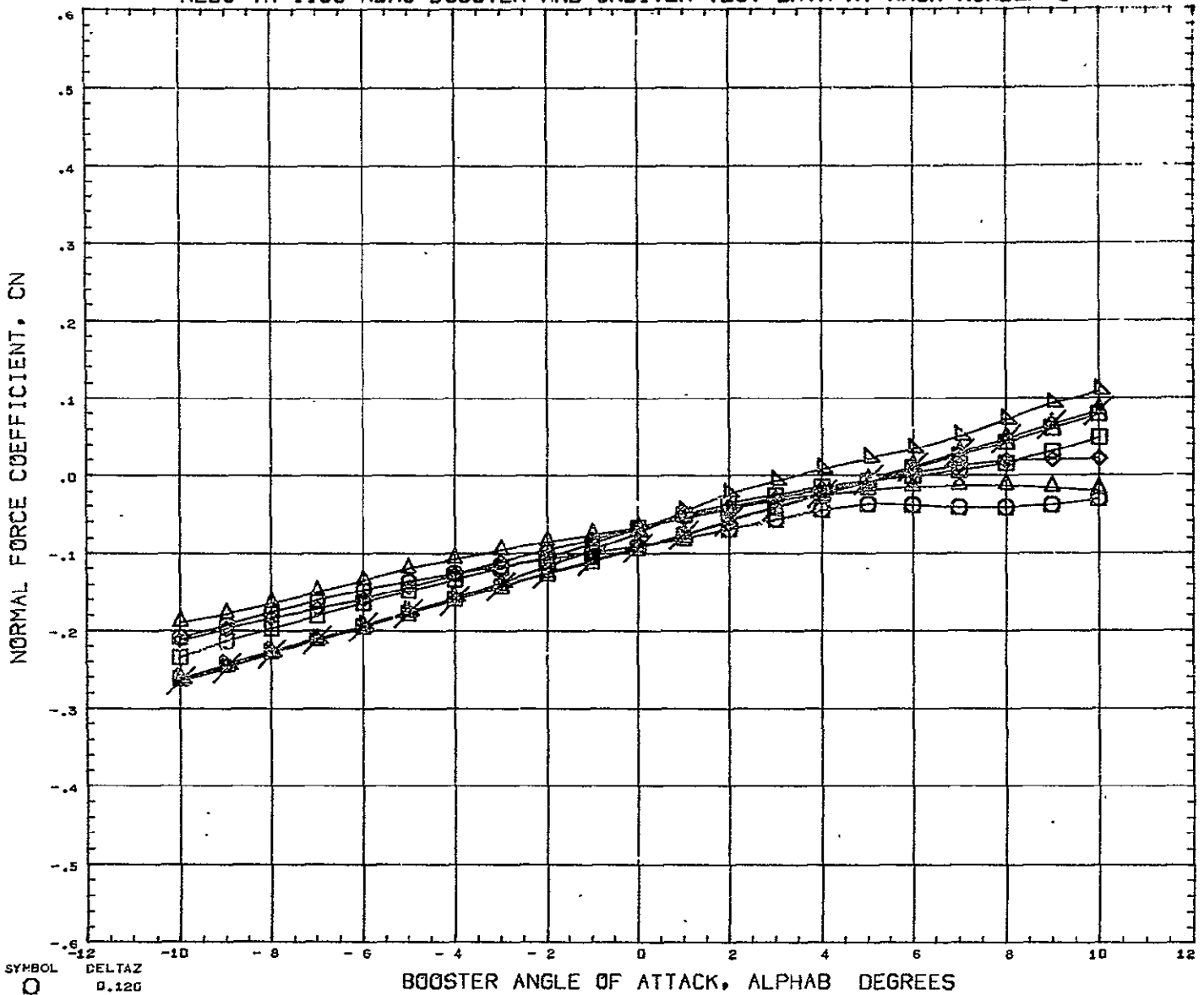

SYMBOL	DELTAZ	PARAMETRIC VALUES				REFERENCE INFORMATION		
○	0.120							
◇	0.151							
△	0.182	P <sup>2</sup> POW	0.000	ORBPOW	0.000	REFS	23.6890	SQ IN
◻	0.228	DELTA X	0.391	ALPHA I	4.900	REFL	4.1930	IN
◼	0.352	MACH	5.010	ELVBST	0.000	REFB	6.5000	IN
◇	0.599	ELVORB	0.000	BETA	0.000	XMRP	4.9170	IN
△	10.000					YMRP	0.0000	IN
						ZMRP	1.3900	IN
						SCALE	0.0055	

REFERENCE FILE

# AEDC VA 1163 MDAC BOOSTER AND ORBITER TEST DATA AT MACH NUMBER 5

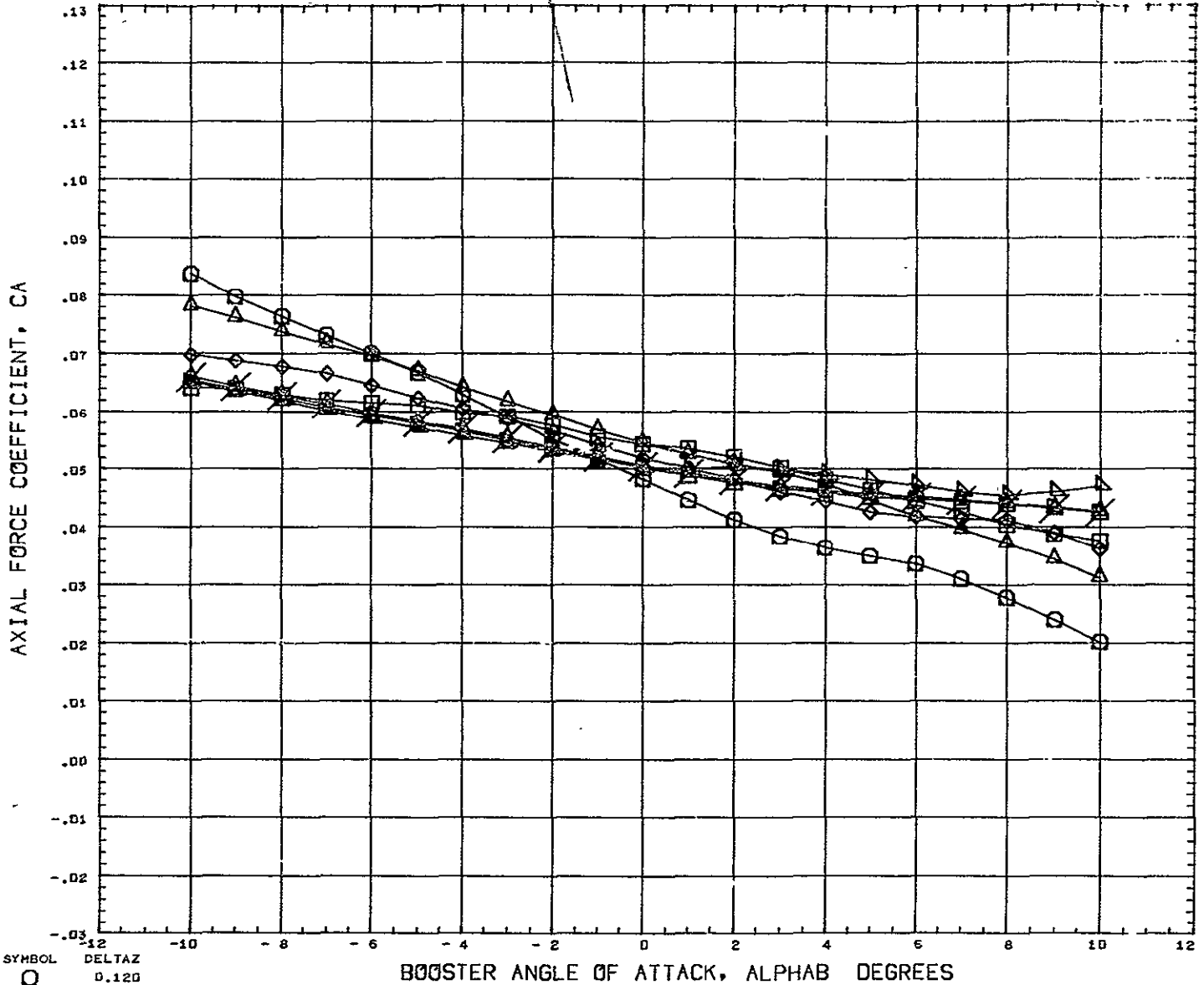

SYMBOL	DELTAZ
○	0.120
□	0.151
◇	0.182
△	0.228
×	0.352
◇	0.599
○	10.000

PARAMETRIC VALUES			
STPOW	0.000	ORBPOW	0.000
DELTAZ	- 0.391	ALPHA1	- 4.900
MACH	5.010	ELVBST	0.000
ELVORB	0.000	BETA	0.000

REFERENCE INFORMATION		
REFS	23.6890	SQ IN
REFL	4.1930	IN
REFB	6.5905	IN
XMRP	4.9175	IN
YMRP	0.0000	IN
ZMRP	1.3900	IN
SCALE	0.0055	

REFERENCE FILE

AEDC VA 1163 MDAC BOOSTER AND ORBITER TEST DATA AT MACH NUMBER 5

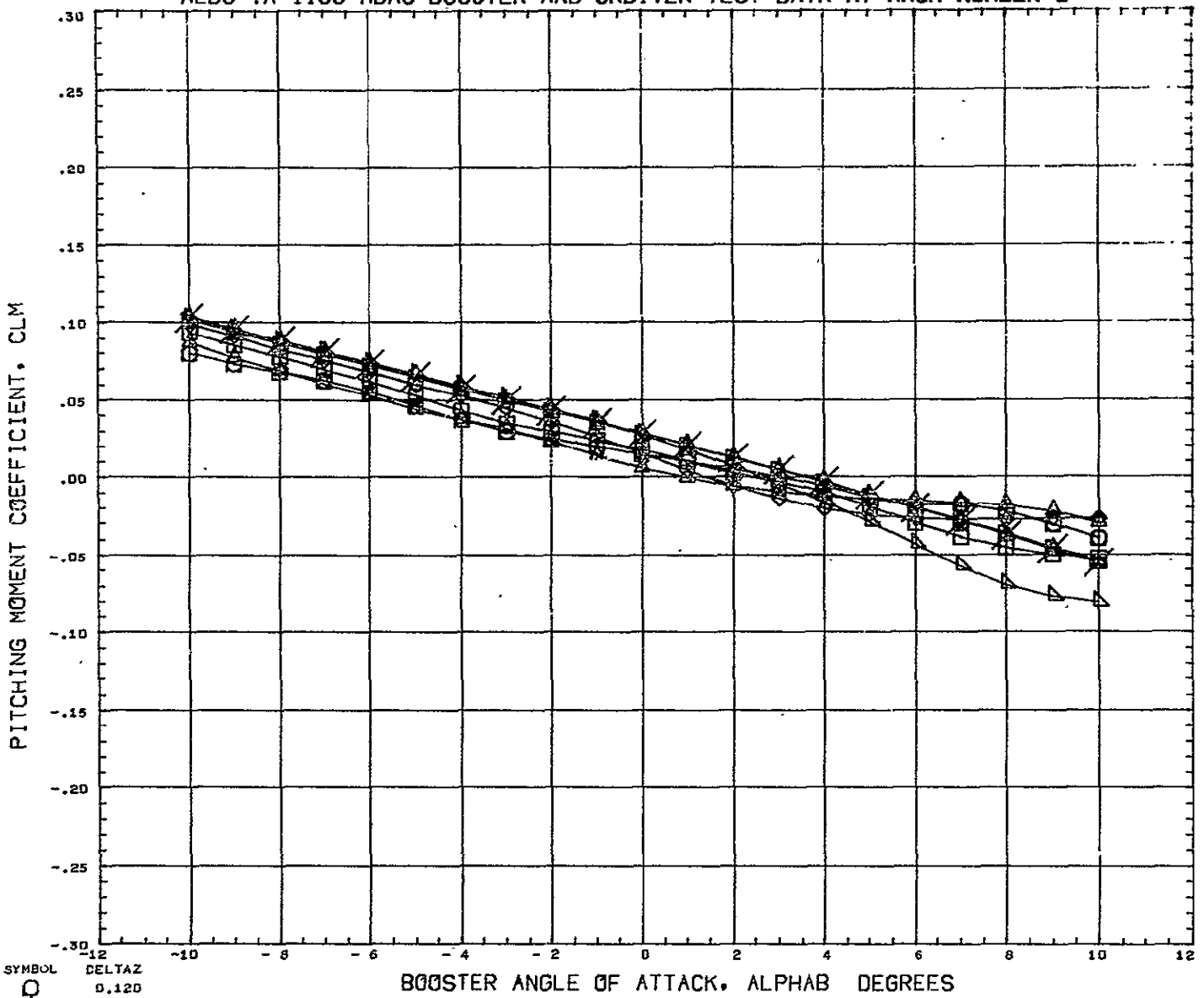

SYMBOL	DELTA Z	PARAMETRIC VALUES				REFERENCE INFORMATION		
○	0.120							
◇	0.151							
◇	0.182	3STFOW	0.000	ORBPOW	0.000	REFS	23.6890	SQ IN
◇	0.228	DELTA X	-0.143	ALPHA I	-4.900	REFL	4.1930	IN
◇	0.352	MACH	5.010	ELVBST	0.000	REFB	6.5000	IN
◇	0.599	ELVORB	0.000	BETA	0.000	XMRP	4.9170	IN
◇	10.000					YMRP	0.0000	IN
						ZMRP	1.3900	IN
						SCALE	0.0055	

REFERENCE FILE

# AEDC VA 1163 MDAC BOOSTER AND ORBITER TEST DATA AT MACH NUMBER 5

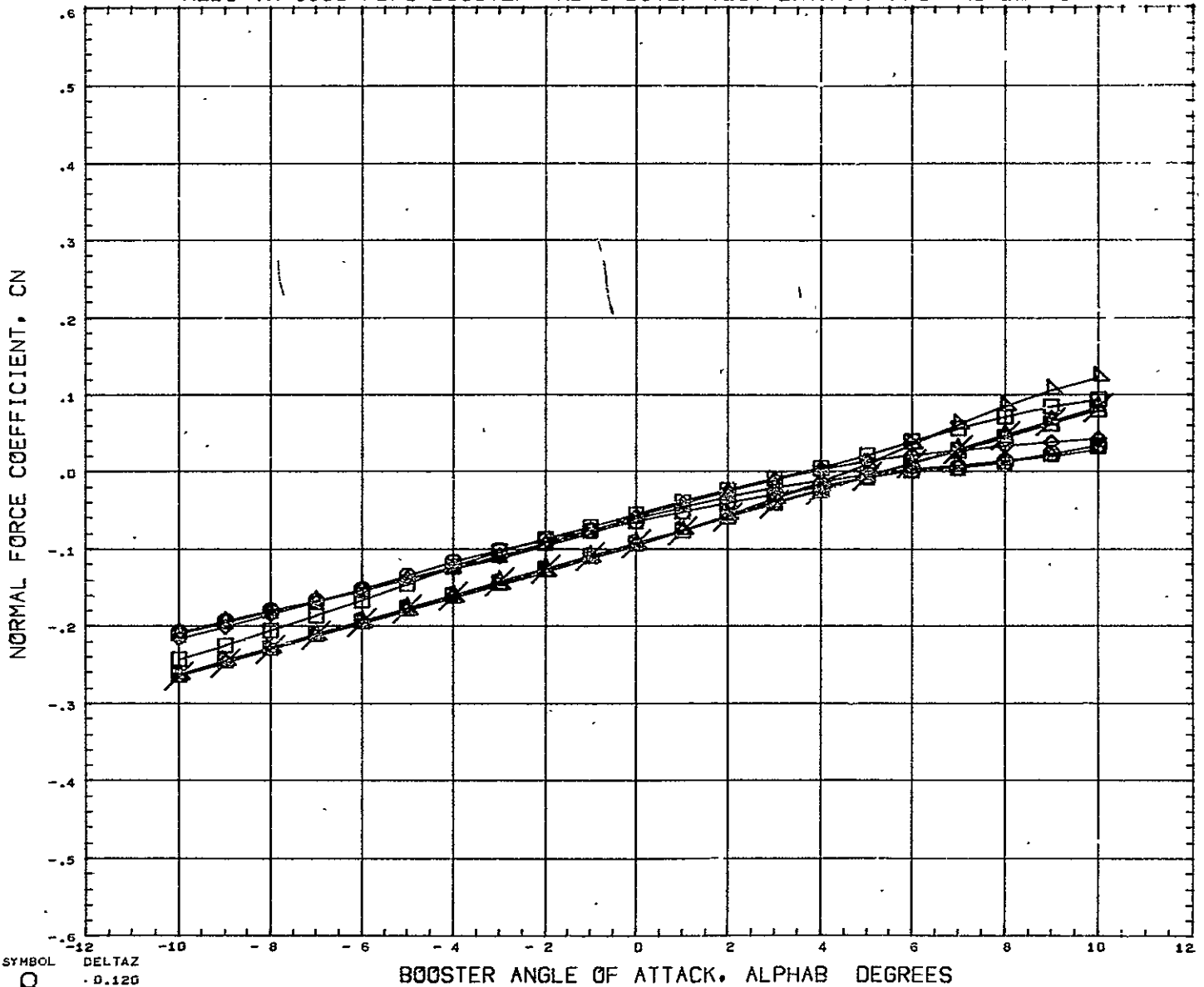

SYMBOL ○ ◇ □ △ ×	DELTA Z 0.120 0.151 0.182 0.228 0.352 0.599 10.000	PARAMETRIC VALUES JSTPOW 0.000 ORBPOW 0.000 DELTAX 0.143 ALPHAI 4.900 MACH 5.010 ELVBST 0.000 ELVORB 0.000 BETA 0.000	REFERENCE INFORMATION REFS 23.6890 SQ IN REFL 4.1930 IN REFB 6.5000 IN XHRF 4.9170 IN YHRF 0.0000 IN ZHRF 1.3900 IN SCALE 0.0055
REFERENCE FILE			

AEDC VA 1163 MDAC BOOSTER AND ORBITER TEST DATA AT MACH NUMBER 5

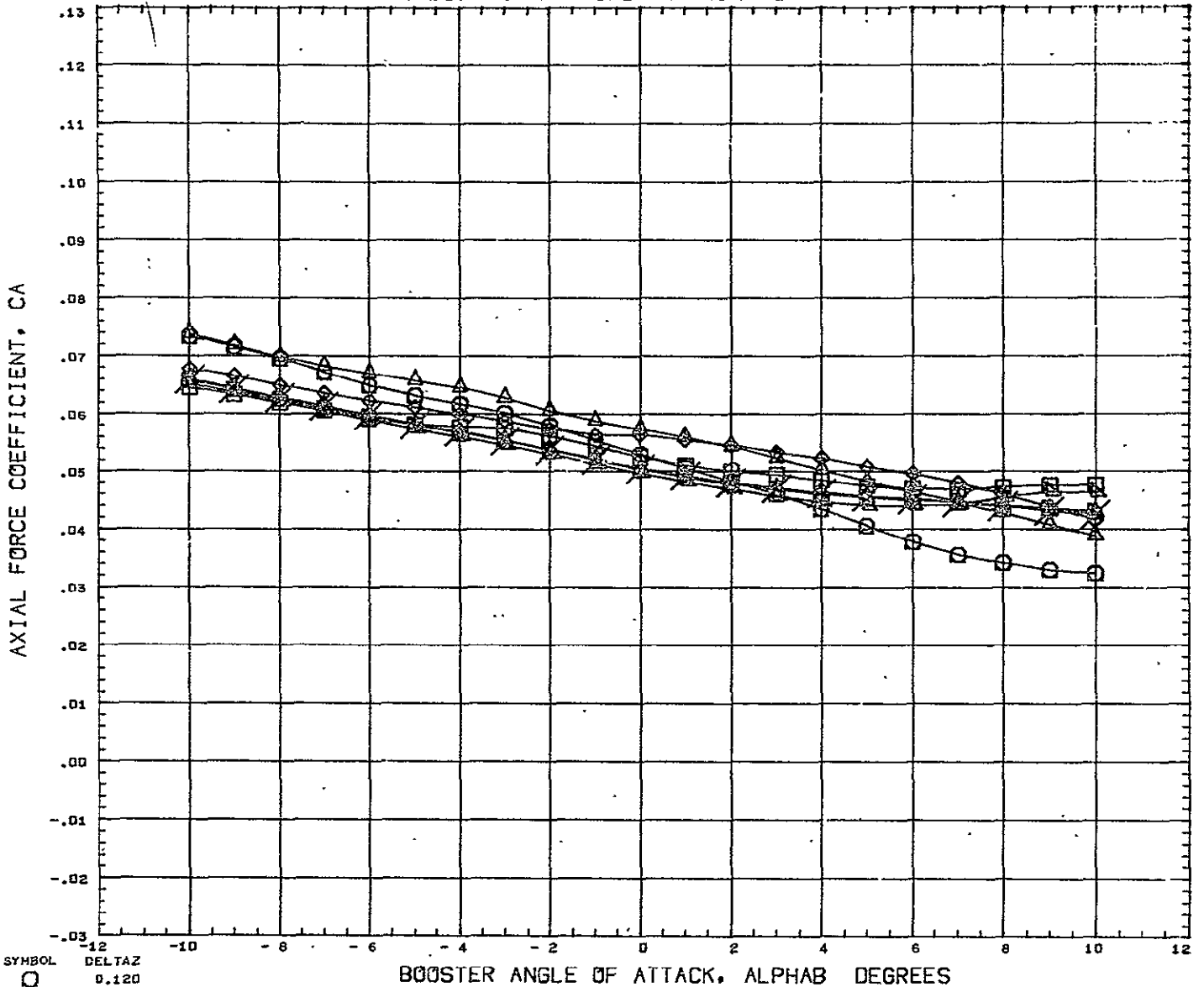

SYMBOL	DELTA Z	PARAMETRIC VALUES				REFERENCE INFORMATION		
○	0.120							
◇	0.151							
△	0.182	BSTPOW	0.000	ORBPOW	0.500	REFS	23.6890	50 IN
□	0.228	JELTAX	- 0.143	ALPHA1	- 4.900	REFL	4.1930	IN
▽	0.352	MACH	5.010	ELVBST	0.000	REFB	6.5000	IN
◇	0.599	ELVORB	0.000	BETA	0.000	XMRP	4.5170	IN
○	10.000					YMRP	0.0000	IN
						ZMRP	1.3900	IN
						SCALE	0.0055	

REFERENCE FILE

# AEDC VA 1163 MDAC BOOSTER AND ORBITER TEST DATA AT MACH NUMBER 5

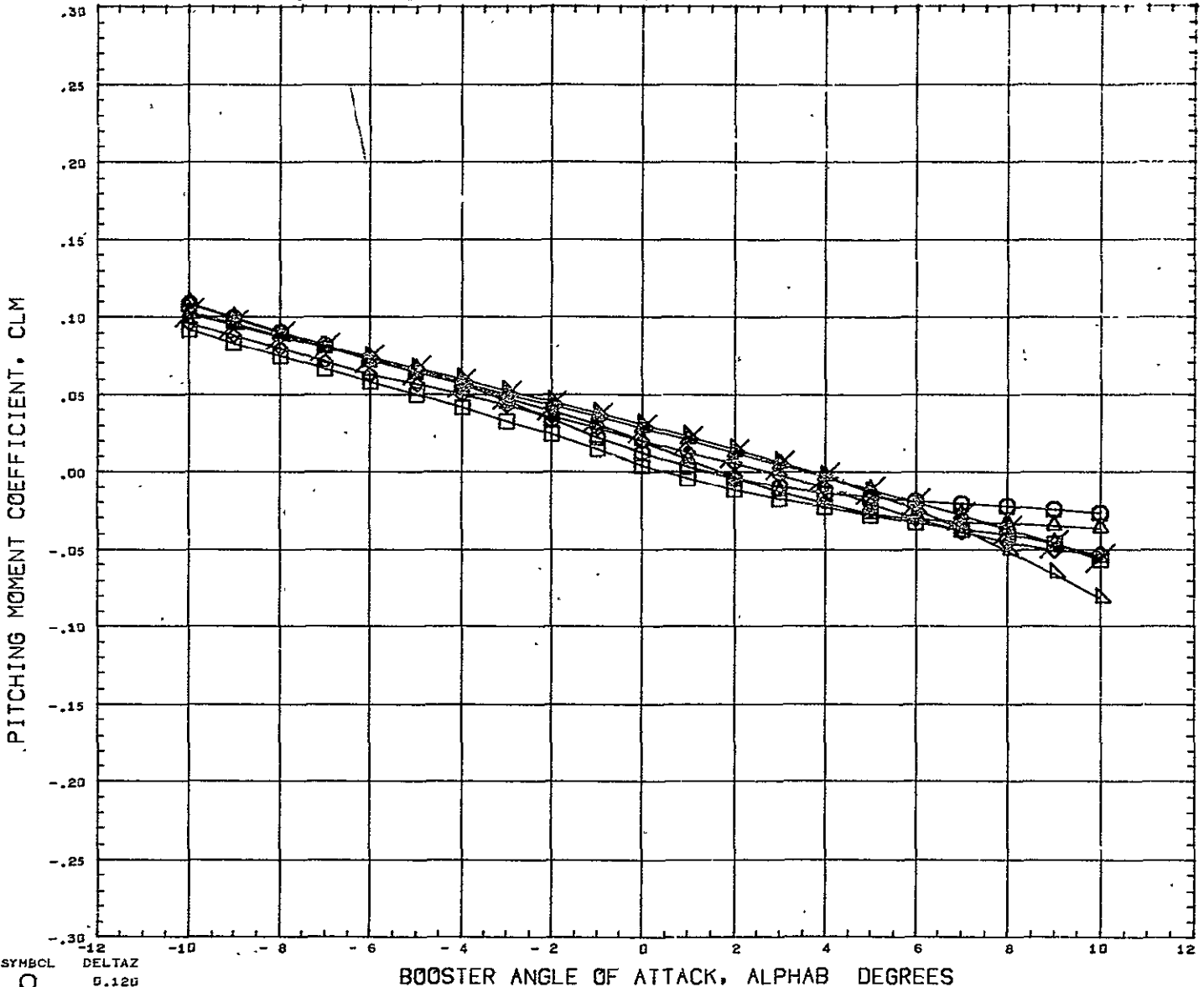

SYMBOL ○ □ △ ◇ ×	DELTAX 0.120 0.151 0.182 0.220 0.352 10.000	<table border="0" style="width: 100%;"> <tr> <th colspan="4" style="text-align: center;">PARAMETRIC VALUES</th> </tr> <tr> <td>RSTPOW</td> <td>0.000</td> <td>ORBFOV</td> <td>0.000</td> </tr> <tr> <td>DELTA</td> <td>- 0.019</td> <td>ALPHA1</td> <td>- 4.900</td> </tr> <tr> <td>MACH</td> <td>5.010</td> <td>ELVBST</td> <td>0.000</td> </tr> <tr> <td>ELVORB</td> <td>0.000</td> <td>BETA</td> <td>0.000</td> </tr> </table>	PARAMETRIC VALUES				RSTPOW	0.000	ORBFOV	0.000	DELTA	- 0.019	ALPHA1	- 4.900	MACH	5.010	ELVBST	0.000	ELVORB	0.000	BETA	0.000	<table border="0" style="width: 100%;"> <tr> <th colspan="3" style="text-align: center;">REFERENCE INFORMATION</th> </tr> <tr> <td>REFS</td> <td>23.6690</td> <td>sq IN</td> </tr> <tr> <td>REFL</td> <td>4.1930</td> <td>IN</td> </tr> <tr> <td>REFB</td> <td>6.5000</td> <td>IN</td> </tr> <tr> <td>XMRP</td> <td>4.9173</td> <td>IN</td> </tr> <tr> <td>ZMRP</td> <td>0.0000</td> <td>IN</td> </tr> <tr> <td>ZMRP</td> <td>1.3900</td> <td>IN</td> </tr> <tr> <td>SCALE</td> <td>0.0055</td> <td></td> </tr> </table>	REFERENCE INFORMATION			REFS	23.6690	sq IN	REFL	4.1930	IN	REFB	6.5000	IN	XMRP	4.9173	IN	ZMRP	0.0000	IN	ZMRP	1.3900	IN	SCALE	0.0055	
PARAMETRIC VALUES																																															
RSTPOW	0.000	ORBFOV	0.000																																												
DELTA	- 0.019	ALPHA1	- 4.900																																												
MACH	5.010	ELVBST	0.000																																												
ELVORB	0.000	BETA	0.000																																												
REFERENCE INFORMATION																																															
REFS	23.6690	sq IN																																													
REFL	4.1930	IN																																													
REFB	6.5000	IN																																													
XMRP	4.9173	IN																																													
ZMRP	0.0000	IN																																													
ZMRP	1.3900	IN																																													
SCALE	0.0055																																														

REFERENCE FILE

# AEDC VA 1163 MDAC BOOSTER AND ORBITER TEST DATA AT MACH NUMBER 5

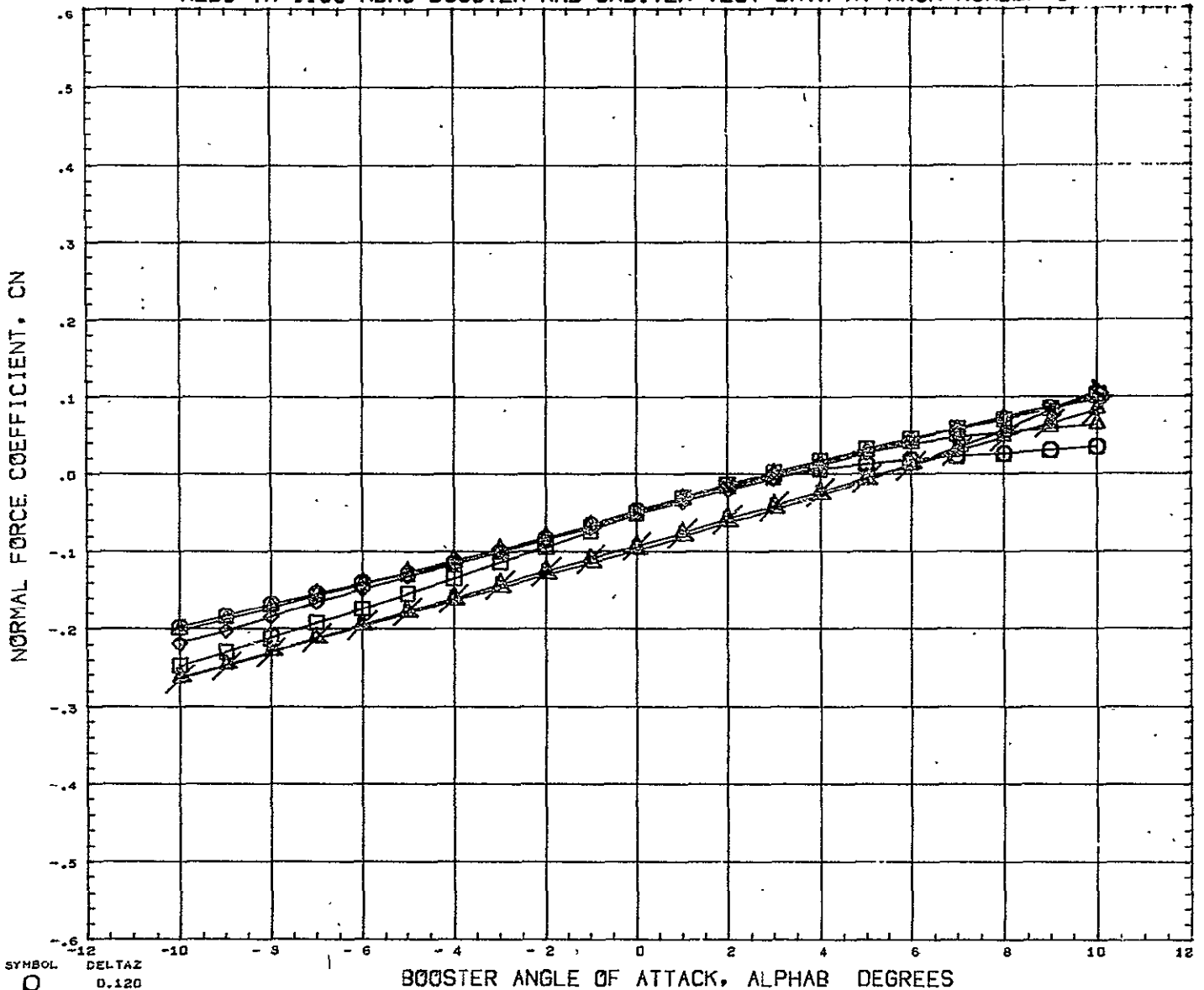

SYMBOL ○ □ △ ◇ ×	DELTA Z 0.120 0.151 0.182 0.228 0.352 10.000	PARAMETRIC VALUES JSTPOW    0.000    ORBFOV    0.000 DELTAX    - 0.019    ALPHA1    - 4.900 MACH       5.010    ELVBST    0.000 ELVORB    0.000    BETA       0.000	REFERENCE INFORMATION REFS       23.6890    SQ IN REFL       4.1930    IN REFB       6.5800    IN XMRP       4.9170    IN YMRP       0.0000    IN ZMRP       1.3900    IN SCALE       0.0055
REFERENCE FILE			

# AEDC VA 1163 MDAC BOOSTER AND ORBITER TEST DATA AT MACH NUMBER 5

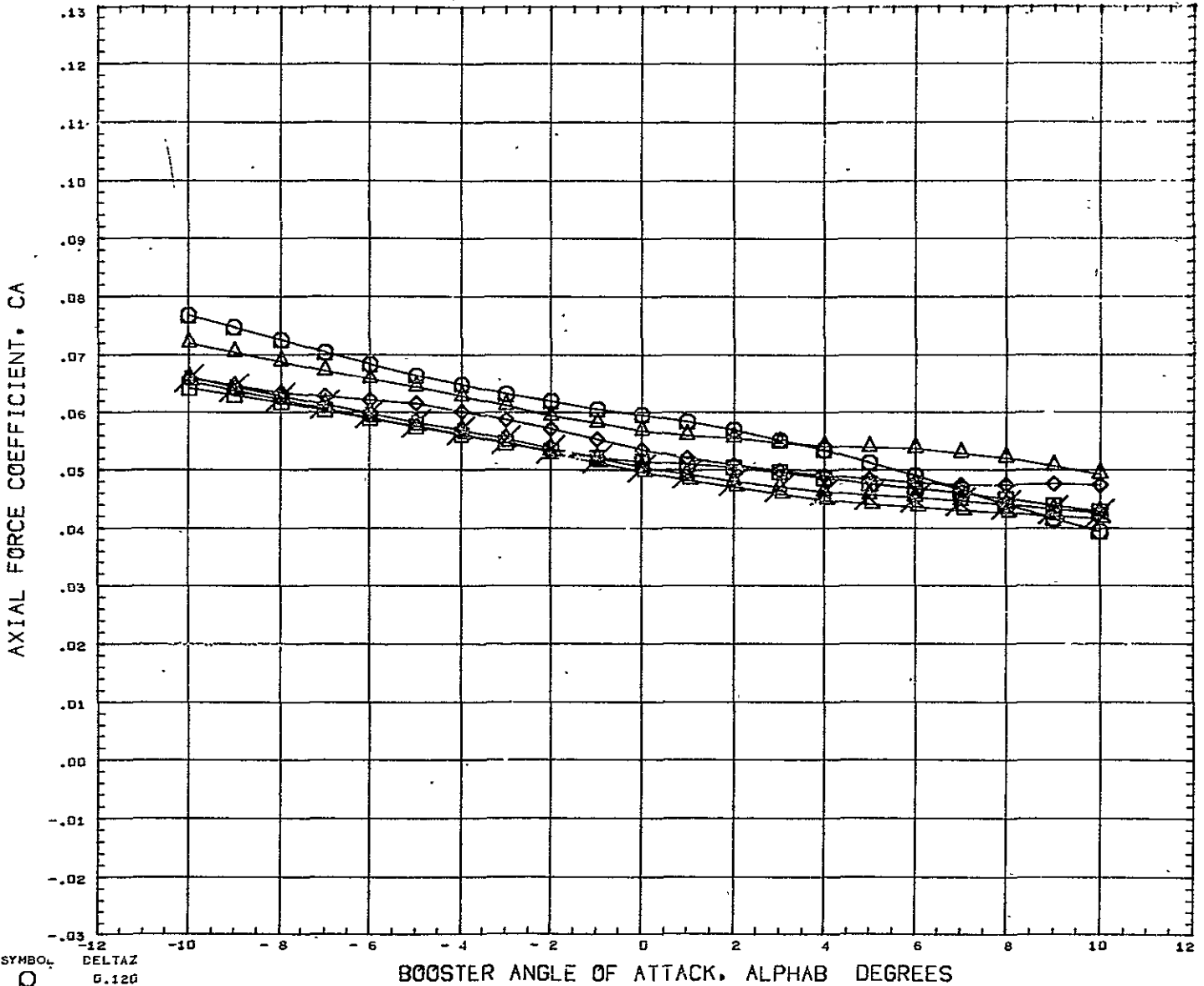

SYMBOL 	DELTAX 0.120 0.151 0.182 0.220 0.352 10.000	<table border="0" style="width: 100%;"> <tr> <th colspan="4" style="text-align: left; padding-bottom: 5px;">PARAMETRIC VALUES</th> </tr> <tr> <td style="padding-right: 10px;">PSTFOW</td> <td style="padding-right: 10px;">0.000</td> <td style="padding-right: 10px;">ORBFOV</td> <td>0.000</td> </tr> <tr> <td>DELTAI</td> <td>- 0.019</td> <td>ALPHA1</td> <td>- 4.900</td> </tr> <tr> <td>MACH</td> <td>5.010</td> <td>ELVBST</td> <td>0.000</td> </tr> <tr> <td>ELVORB</td> <td>0.000</td> <td>BETA</td> <td>0.000</td> </tr> </table>	PARAMETRIC VALUES				PSTFOW	0.000	ORBFOV	0.000	DELTAI	- 0.019	ALPHA1	- 4.900	MACH	5.010	ELVBST	0.000	ELVORB	0.000	BETA	0.000	<table border="0" style="width: 100%;"> <tr> <th colspan="3" style="text-align: left; padding-bottom: 5px;">REFERENCE INFORMATION</th> </tr> <tr> <td>REFS</td> <td>23.6890</td> <td>SQ IN</td> </tr> <tr> <td>REFL</td> <td>4.1930</td> <td>IN</td> </tr> <tr> <td>REFB</td> <td>6.5000</td> <td>IN</td> </tr> <tr> <td>XMRP</td> <td>4.9170</td> <td>IN</td> </tr> <tr> <td>YMRP</td> <td>0.0000</td> <td>IN</td> </tr> <tr> <td>ZMRP</td> <td>1.3900</td> <td>IN</td> </tr> <tr> <td>SCALE</td> <td>0.0055</td> <td></td> </tr> </table>	REFERENCE INFORMATION			REFS	23.6890	SQ IN	REFL	4.1930	IN	REFB	6.5000	IN	XMRP	4.9170	IN	YMRP	0.0000	IN	ZMRP	1.3900	IN	SCALE	0.0055	
PARAMETRIC VALUES																																															
PSTFOW	0.000	ORBFOV	0.000																																												
DELTAI	- 0.019	ALPHA1	- 4.900																																												
MACH	5.010	ELVBST	0.000																																												
ELVORB	0.000	BETA	0.000																																												
REFERENCE INFORMATION																																															
REFS	23.6890	SQ IN																																													
REFL	4.1930	IN																																													
REFB	6.5000	IN																																													
XMRP	4.9170	IN																																													
YMRP	0.0000	IN																																													
ZMRP	1.3900	IN																																													
SCALE	0.0055																																														

REFERENCE FILE



# AEDC VA 1163 MDAC BOOSTER AND ORBITER TEST DATA AT MACH NUMBER 5

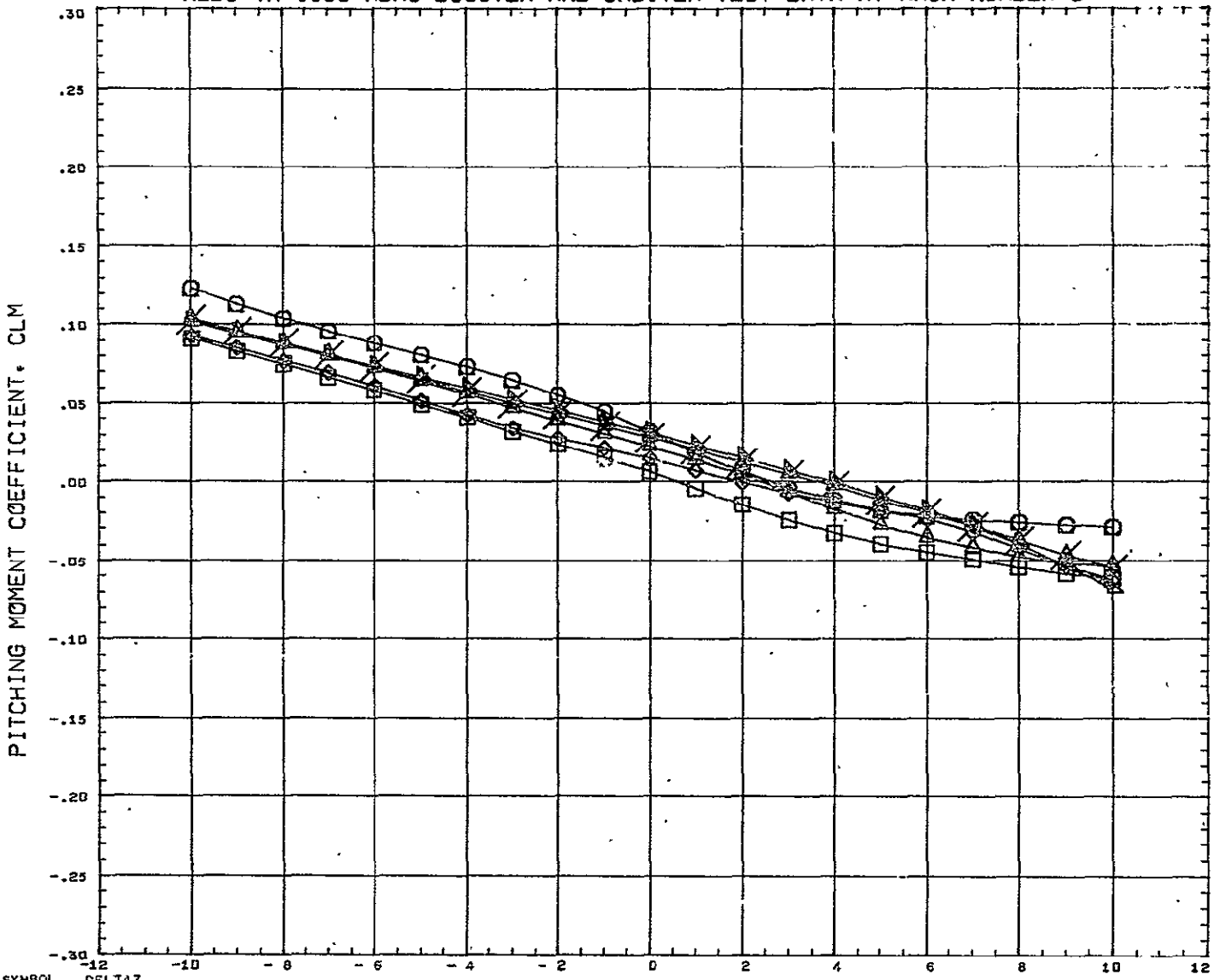

SYMBOL 	DELTA Z 0.120 0.151 0.182 0.228 0.352 10.000	<table border="0" style="width: 100%;"> <tr> <th colspan="4" style="text-align: left; padding-left: 20px;">PARAMETRIC VALUES</th> </tr> <tr> <td style="padding-right: 10px;">JTPOW</td> <td style="padding-right: 10px;">0.000</td> <td style="padding-right: 10px;">ORBPOW</td> <td style="padding-right: 10px;">0.000</td> </tr> <tr> <td>DELTA X</td> <td>0.043</td> <td>ALPHA I</td> <td>-4.900</td> </tr> <tr> <td>MACH</td> <td>5.010</td> <td>ELVBST</td> <td>0.000</td> </tr> <tr> <td>ELVORB</td> <td>0.000</td> <td>BETA</td> <td>0.000</td> </tr> </table>	PARAMETRIC VALUES				JTPOW	0.000	ORBPOW	0.000	DELTA X	0.043	ALPHA I	-4.900	MACH	5.010	ELVBST	0.000	ELVORB	0.000	BETA	0.000	<table border="0" style="width: 100%;"> <tr> <th colspan="3" style="text-align: left;">REFERENCE INFORMATION</th> </tr> <tr> <td>REFS</td> <td>23.6890</td> <td>sq IN</td> </tr> <tr> <td>REFL</td> <td>4.1930</td> <td>IN</td> </tr> <tr> <td>REFB</td> <td>6.5000</td> <td>IN</td> </tr> <tr> <td>XMRP</td> <td>4.9170</td> <td>IN</td> </tr> <tr> <td>YMRP</td> <td>0.0000</td> <td>IN</td> </tr> <tr> <td>ZMRP</td> <td>1.3900</td> <td>IN</td> </tr> <tr> <td>SCALE</td> <td>0.0055</td> <td></td> </tr> </table>	REFERENCE INFORMATION			REFS	23.6890	sq IN	REFL	4.1930	IN	REFB	6.5000	IN	XMRP	4.9170	IN	YMRP	0.0000	IN	ZMRP	1.3900	IN	SCALE	0.0055	
PARAMETRIC VALUES																																															
JTPOW	0.000	ORBPOW	0.000																																												
DELTA X	0.043	ALPHA I	-4.900																																												
MACH	5.010	ELVBST	0.000																																												
ELVORB	0.000	BETA	0.000																																												
REFERENCE INFORMATION																																															
REFS	23.6890	sq IN																																													
REFL	4.1930	IN																																													
REFB	6.5000	IN																																													
XMRP	4.9170	IN																																													
YMRP	0.0000	IN																																													
ZMRP	1.3900	IN																																													
SCALE	0.0055																																														
REFERENCE FILE																																															

# AEDC VA 1163 MDAC BOOSTER AND ORBITER TEST DATA AT MACH NUMBER 5

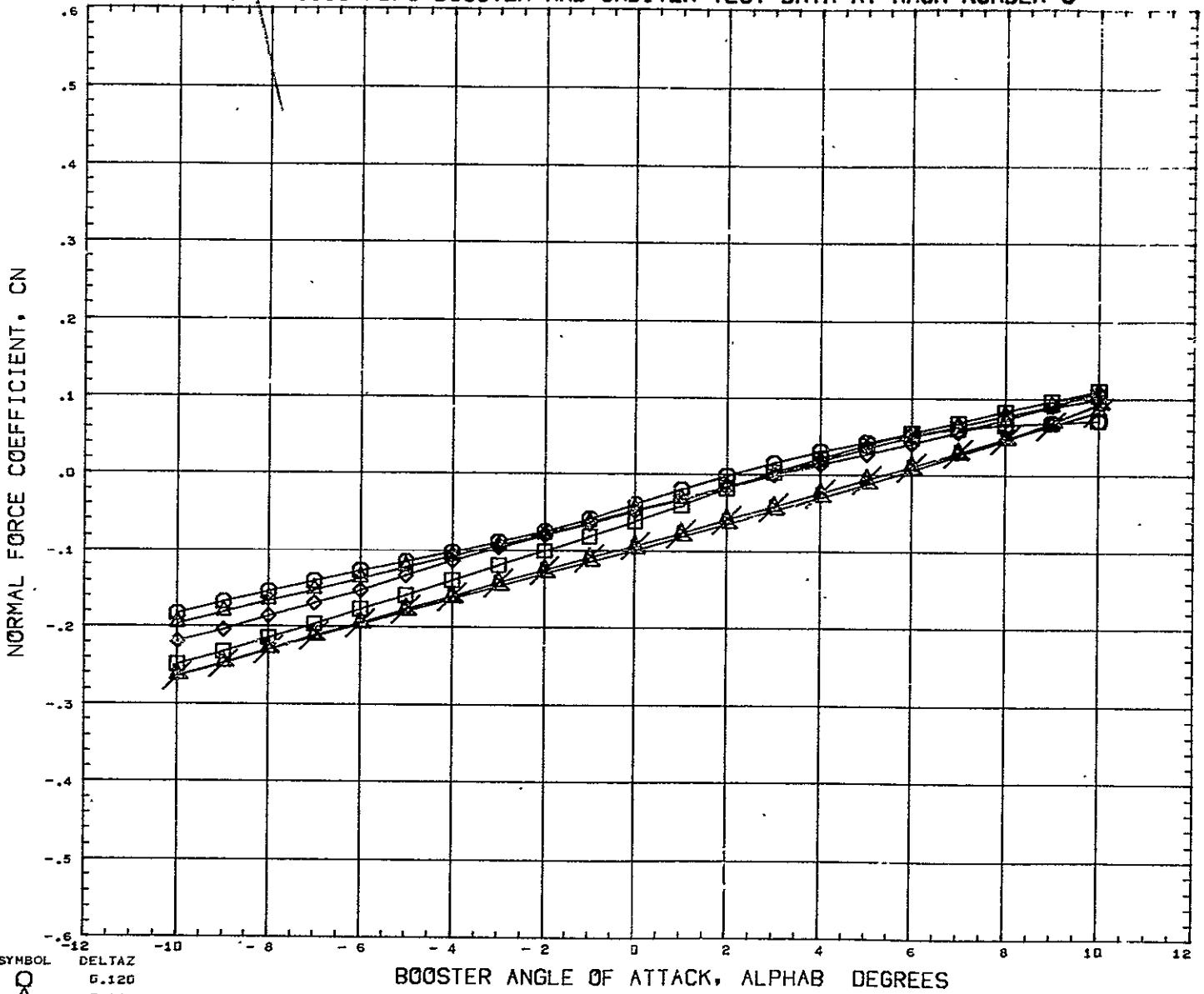

SYMBOL ○ ◇ □ △	DELTAZ 0.120 0.151 0.182 0.228 0.352 10.000	PARAMETRIC VALUES STPOW    0.000    ORBPOW    0.000 DELTAX   0.043    ALPHAI   - 4.900 MACH     5.010    ELVBST   0.000 ELVORB   0.000    BETA     0.000	REFERENCE INFORMATION REFS    23.6899    SQ IN REFL    4.1930    IN REFB    6.5000    IN XMRP    4.9170    IN YMRP    0.0000    IN ZMRP    1.3900    IN SCALE    0.0055
----------------------------	---	--	--

REFERENCE FILE

# AEDC VA 1163 MDAC BOOSTER AND ORBITER TEST DATA AT MACH NUMBER 5

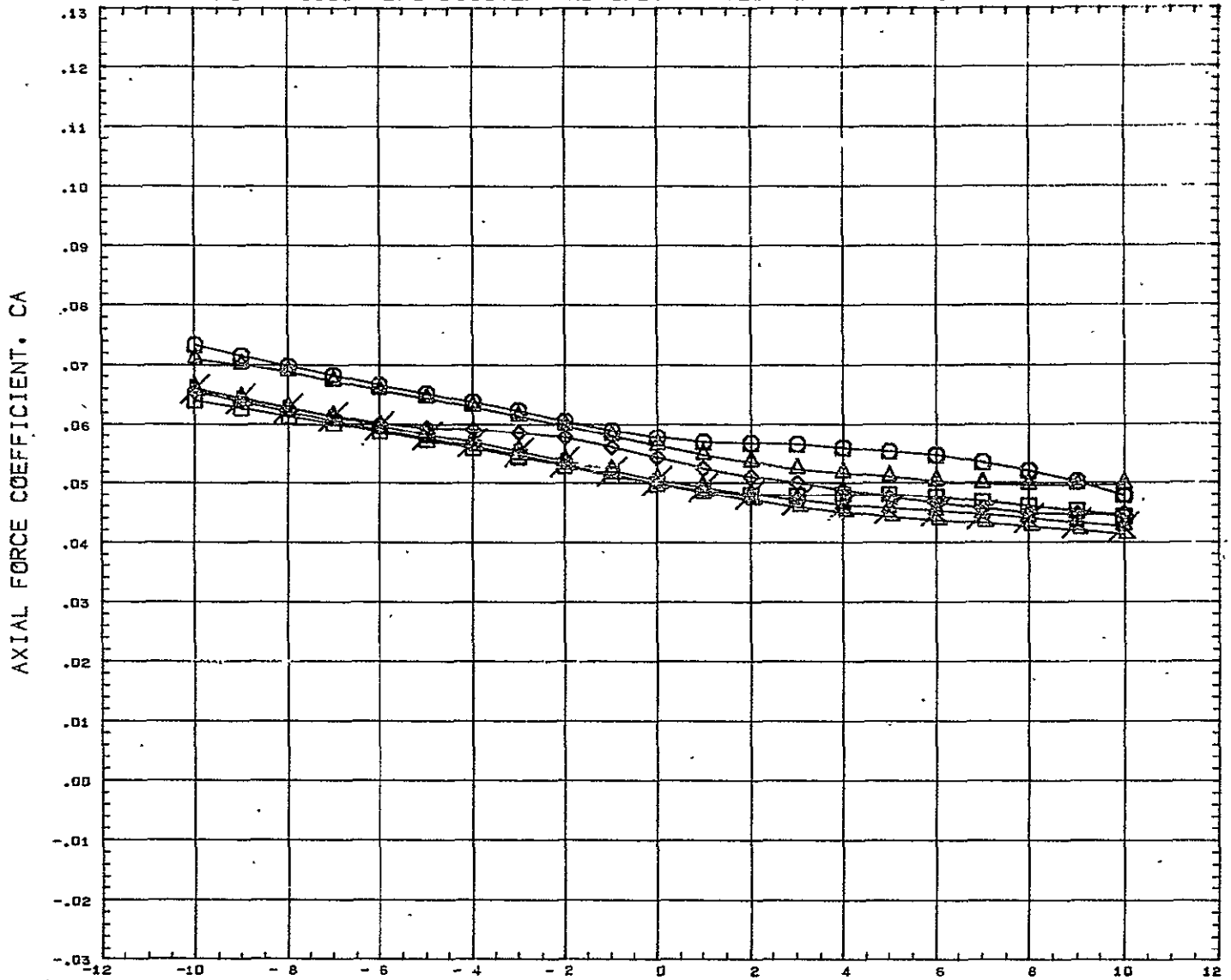

SYMBOL 	DELTAZ 0.120 0.151 0.182 0.228 0.352 10.000	PARAMETRIC VALUES ORBPOW 0.000 DELTAX 0.043 MACH 5.010 ELVORB 0.000 ALPHAI - 4.900 ELVBST 0.000 BETA 0.000	REFERENCE INFORMATION REFS 23.6890 SQ IN REFL 4.1930 IN REFB 6.5000 IN XMRP 4.9170 IN YMRP 0.0000 IN ZMRP 1.3900 IN SCALE 0.0055
------------	---	---	---

REFERENCE FILE

# AEDC VA 1163 MDAC BOOSTER AND ORBITER TEST DATA AT MACH NUMBER 5

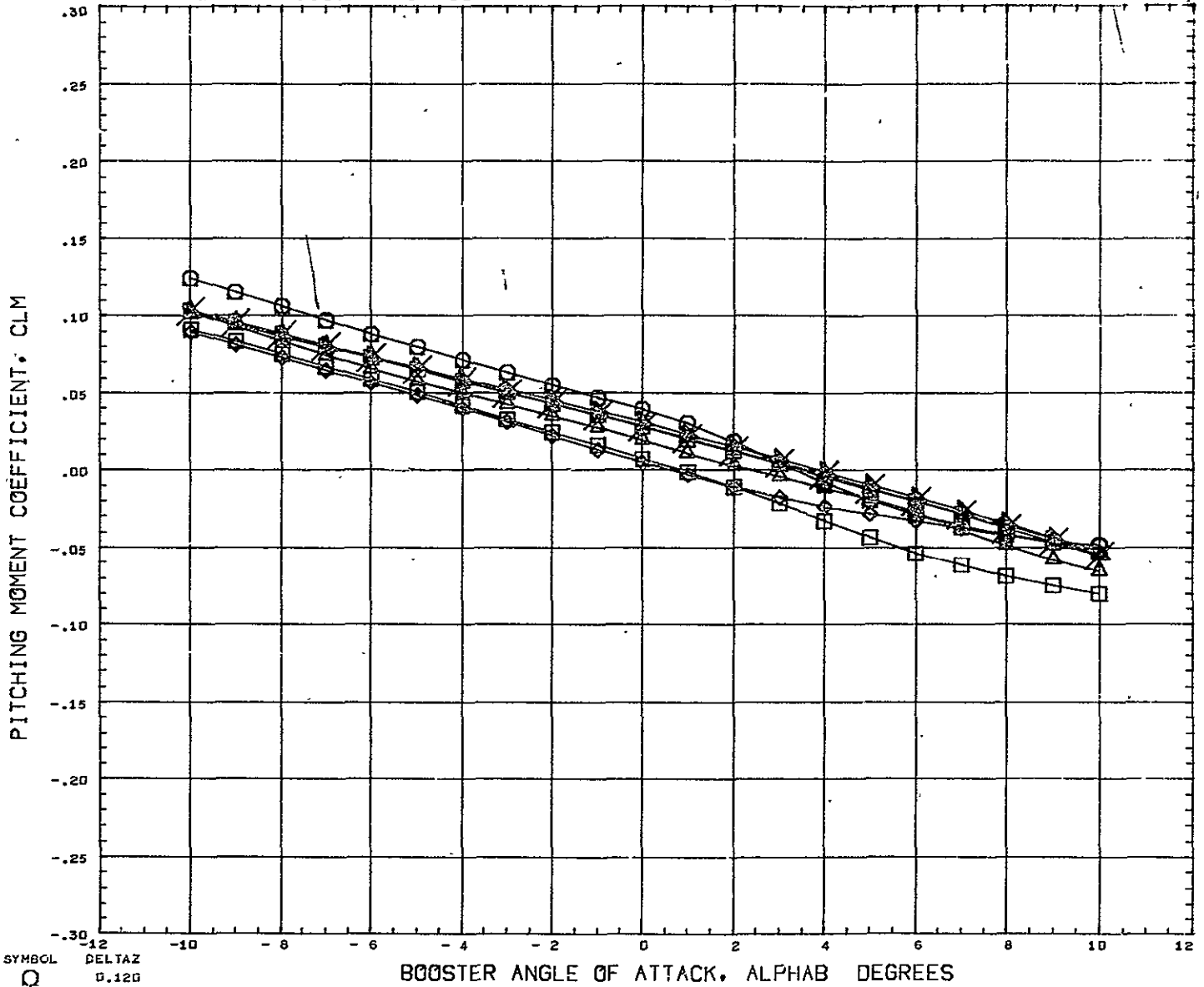

SYMBOL ○ □ △ ×	DELTA Z 0.120 0.151 0.182 0.228 0.352 0.599 10.000	PARAMETRIC VALUES BSTFOW 0.000 ORBPOW 0.000 ELTAX 0.105 ALPHAI 4.900 MACH 5.010 ELVBST 0.000 ELVORB 0.000 BETA 0.000	REFERENCE INFORMATION REFS 23.6890 SQ IN REFL 4.1930 IN REFB 6.5000 IN XMRP 4.9170 IN YMRP 0.0000 IN ZMRP 1.3900 IN SCALE 0.0055
REFERENCE FILE			

AEDC VA 1163 MDAC BOOSTER AND ORBITER TEST DATA AT MACH NUMBER 5

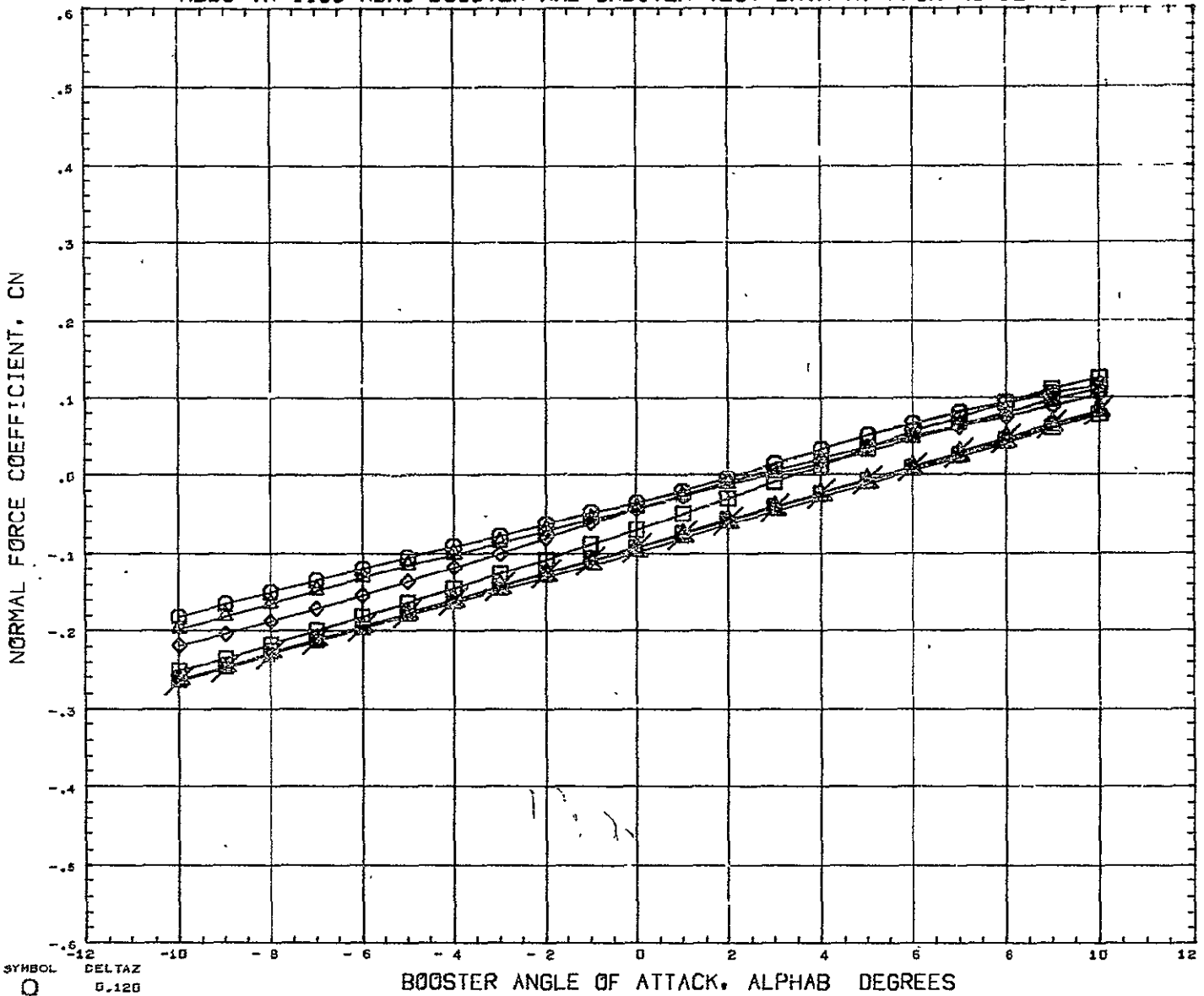

SYMBOL ○ ◇ □ △ ▽ ▲	DELTA Z	PARAMETRIC VALUES				REFERENCE INFORMATION		
	0.120	BSTPOW	0.000	ORBPOW	0.000	REFS	23.6890	SQ IN
	0.151	JELTAX	0.105	ALPHA1	4.900	REFL	4.1930	IN
	0.182	MACH	5.010	ELVBST	0.000	REFB	6.5000	IN
	0.228	ELVORB	0.000	BETA	0.000	XMRP	4.9170	IN
	0.352					YMRP	0.0000	IN
	0.599					ZMRP	1.3900	IN
10.000					SCALE	0.0055	IN	
	REFERENCE FILE							

# AEDC VA 1163 MDAC BOOSTER AND ORBITER TEST DATA AT MACH NUMBER 5

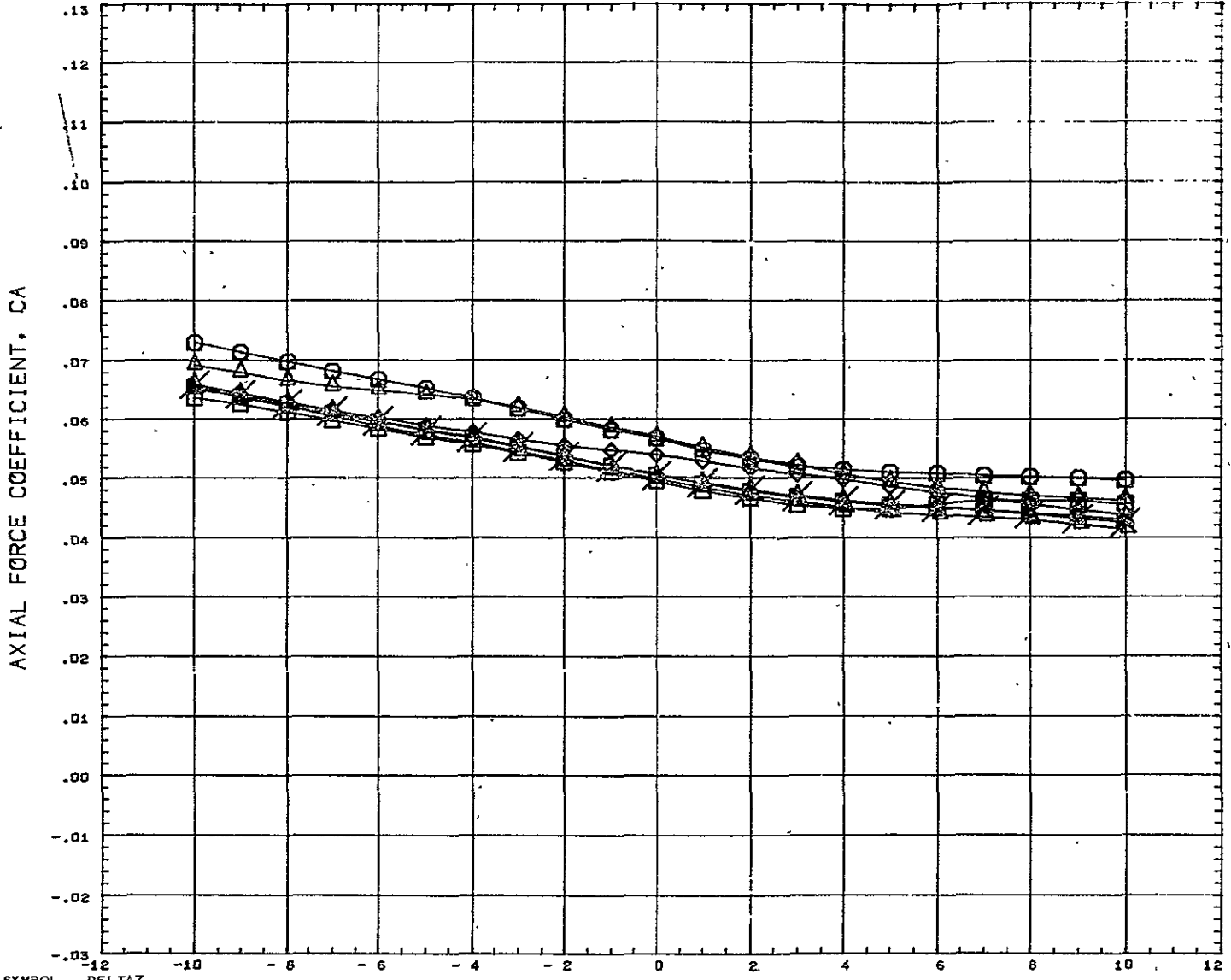

SYMBOL ○ ◇ □ △ ×	DELTA Z 0.120 0.151 0.182 0.228 0.352 0.599 10.000	PARAMETRIC VALUES BSTFOW 0.000    ORBPOW 0.000 I_LTAX 0.105    ALPHAI - 4.900 MACH 5.010    ELVBST 0.000 ELVORB 0.000    BETA 0.000	REFERENCE INFORMATION REFS 23.6890    SQ IN REFL 4.1930    IN REFB 6.5000    IN XMRF 4.9170    IN YMRP 0.0000    IN ZMRP 1.3900    IN SCALE 0.0055
REFERENCE FILE			

# AEDC VA 1163 MDAC BOOSTER AND ORBITER TEST DATA AT MACH NUMBER 5

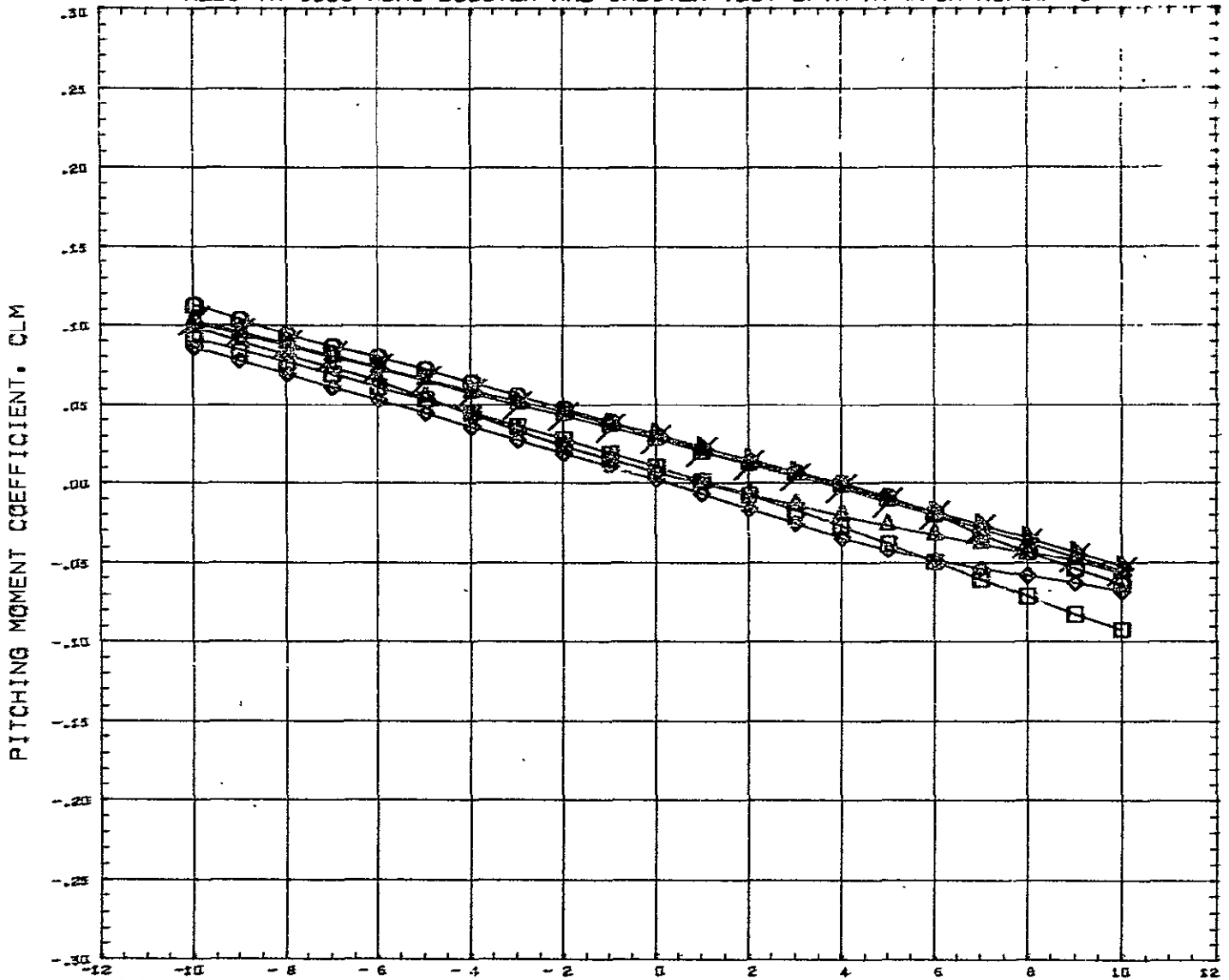

SYMBOL ○ ◇ □ △ ×	DELTA Z 0.120 0.151 0.182 0.228 0.352 10.000	PARAMETRIC VALUES RSTFOW 0.000 ORB FOW 0.000 LELTAX 0.167 ALPHAI - 4.900 MACH 5.010 ELVBST 0.000 ELVORB 0.000 BETA 0.000	REFERENCE INFORMATION REFS 23.6890 SQ IN REFL 4.1930 IN REFB 6.5000 IN XMRP 4.9170 IN YMRP 0.0000 IN ZMRP 1.3900 IN SCALE 0.0055
---------------------------------	--	--	---

REFERENCE FILE

# AEDC VA 1163 MDAC BOOSTER AND ORBITER TEST DATA AT MACH NUMBER 5

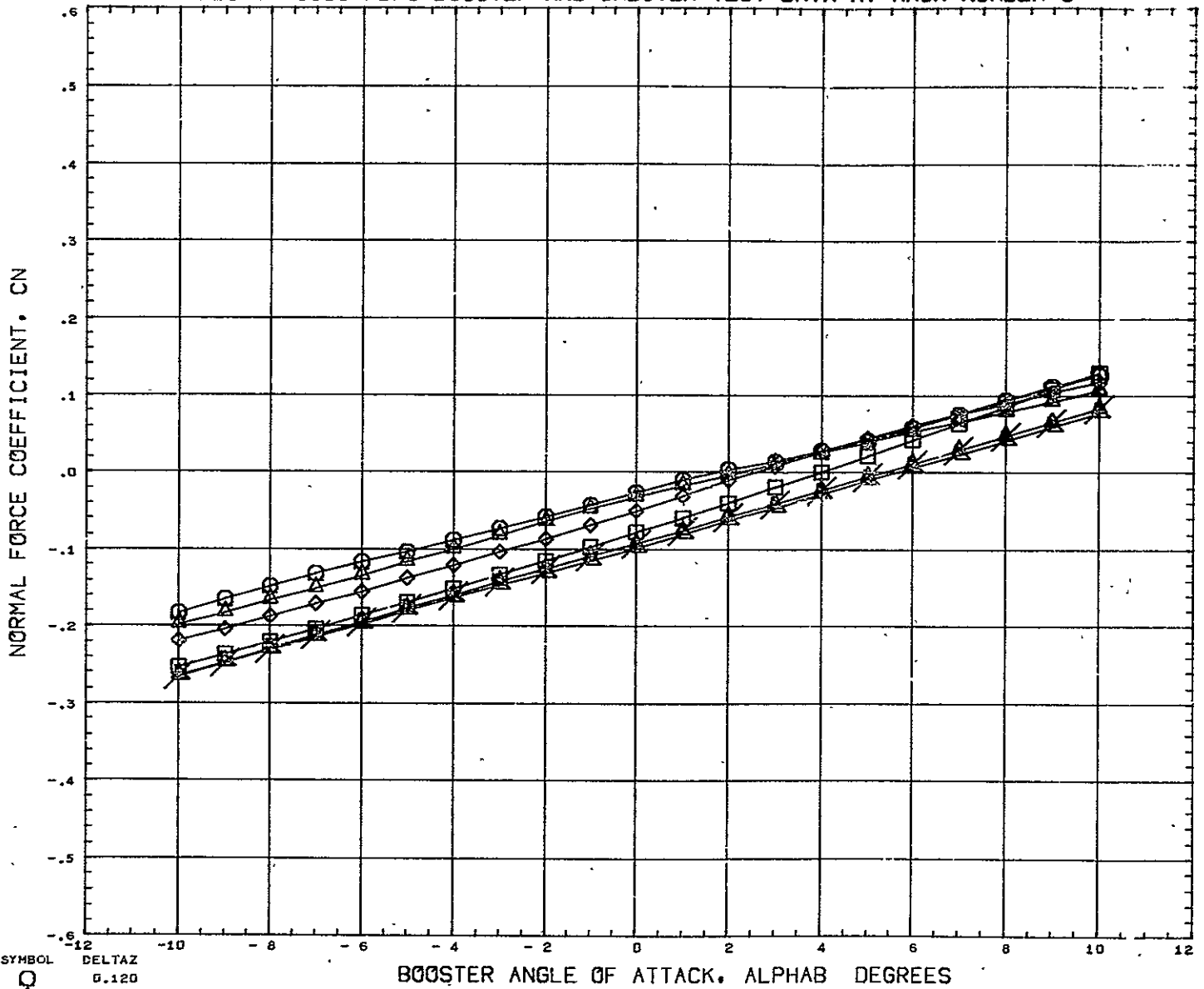

SYMBOL  
 ○  
 ◇  
 □  
 △  
 ▽  
 ×

DELTAZ	0.120	PARAMETRIC VALUES	
0.151		ORBPOW	0.000
0.182	ORBPOW	0.000	0.000
0.228	DELTAZ	0.167	ALPHA1 - 4.900
0.352	MACH	5.010	ELVBST 0.000
10.000	ELVORB	0.000	BETA 0.000

REFERENCE FILE

REFERENCE INFORMATION		
REFS	23.6890	SQ IN
REFL	4.1930	IN
REFB	6.5000	IN
XMRP	4.9170	IN
YMRP	0.0000	IN
ZMRP	1.3900	IN
SCALE	0.0055	



# AEDC VA 1163 MDAC BOOSTER AND ORBITER TEST DATA AT MACH NUMBER 5

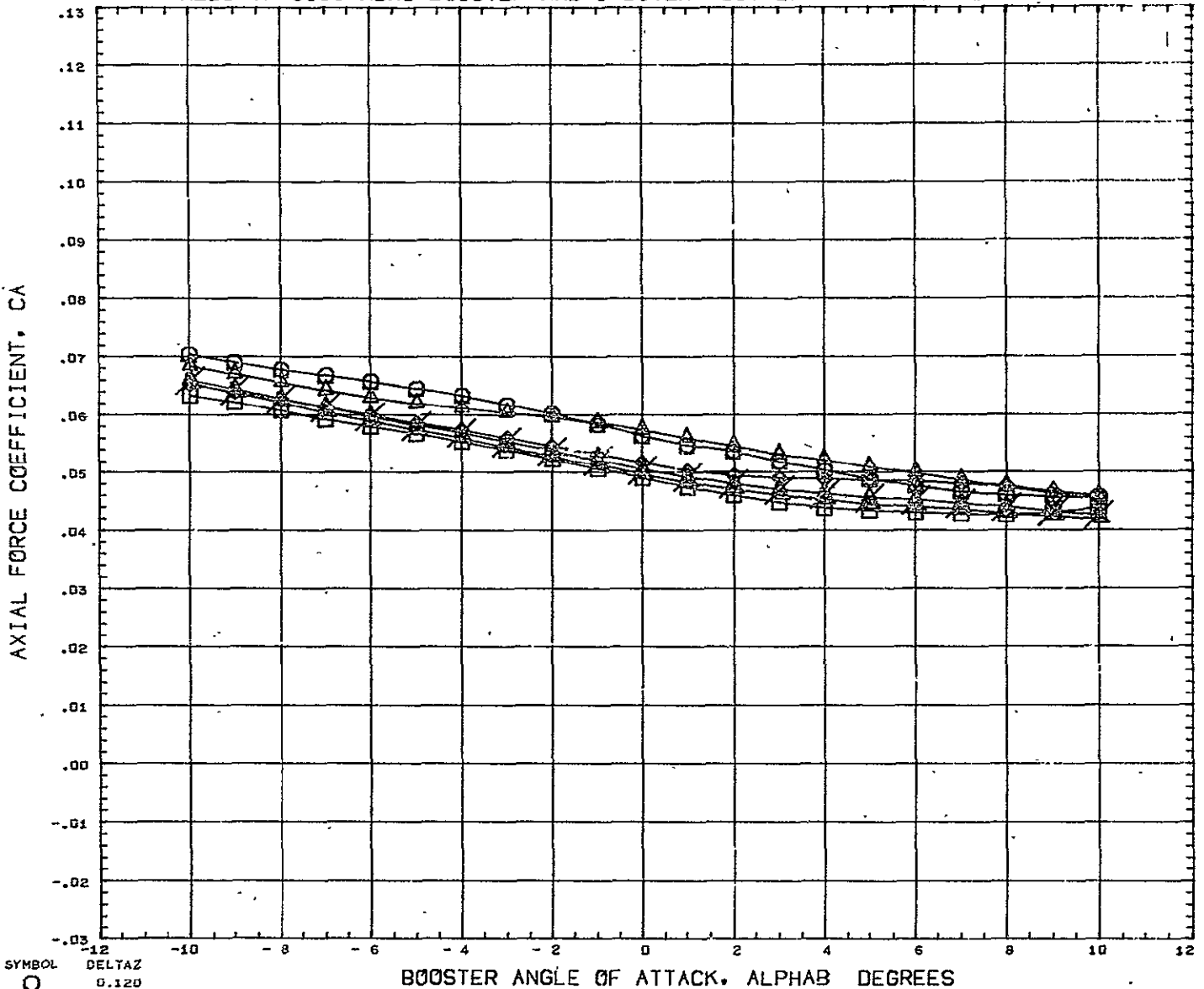

SYMBOL ○ ◊ ◻ △ ▽	DELTA Z 0.120 0.151 0.182 0.228 0.352 10.000	<table border="0" style="width: 100%;"> <tr> <th colspan="4" style="text-align: left;">PARAMETRIC VALUES</th> </tr> <tr> <td style="width: 25%;">: JTFOW</td> <td style="width: 25%;">0.000</td> <td style="width: 25%;">ORBFOW</td> <td style="width: 25%;">0.000</td> </tr> <tr> <td>DELTA X</td> <td>0.167</td> <td>ALPHA 1</td> <td>- 4.900</td> </tr> <tr> <td>MACH</td> <td>5.010</td> <td>ELVBST</td> <td>0.000</td> </tr> <tr> <td>ELVORB</td> <td>0.000</td> <td>BETA</td> <td>0.000</td> </tr> </table>	PARAMETRIC VALUES				: JTFOW	0.000	ORBFOW	0.000	DELTA X	0.167	ALPHA 1	- 4.900	MACH	5.010	ELVBST	0.000	ELVORB	0.000	BETA	0.000	<table border="0" style="width: 100%;"> <tr> <th colspan="3" style="text-align: left;">REFERENCE INFORMATION</th> </tr> <tr> <td style="width: 33%;">REFS</td> <td style="width: 33%;">23.6890</td> <td style="width: 33%;">SQ IN</td> </tr> <tr> <td>REFL</td> <td>4.1930</td> <td>IN</td> </tr> <tr> <td>REFB</td> <td>6.5000</td> <td>IN</td> </tr> <tr> <td>XHRF</td> <td>4.9170</td> <td>IN</td> </tr> <tr> <td>YHRF</td> <td>0.0000</td> <td>IN</td> </tr> <tr> <td>ZHRF</td> <td>1.3900</td> <td>IN</td> </tr> <tr> <td>SCALE</td> <td>0.0055</td> <td></td> </tr> </table>	REFERENCE INFORMATION			REFS	23.6890	SQ IN	REFL	4.1930	IN	REFB	6.5000	IN	XHRF	4.9170	IN	YHRF	0.0000	IN	ZHRF	1.3900	IN	SCALE	0.0055	
PARAMETRIC VALUES																																															
: JTFOW	0.000	ORBFOW	0.000																																												
DELTA X	0.167	ALPHA 1	- 4.900																																												
MACH	5.010	ELVBST	0.000																																												
ELVORB	0.000	BETA	0.000																																												
REFERENCE INFORMATION																																															
REFS	23.6890	SQ IN																																													
REFL	4.1930	IN																																													
REFB	6.5000	IN																																													
XHRF	4.9170	IN																																													
YHRF	0.0000	IN																																													
ZHRF	1.3900	IN																																													
SCALE	0.0055																																														
REFERENCE FILE																																															

# AEDC VA 1163 MDAC BOOSTER AND ORBITER TEST DATA AT MACH NUMBER 5

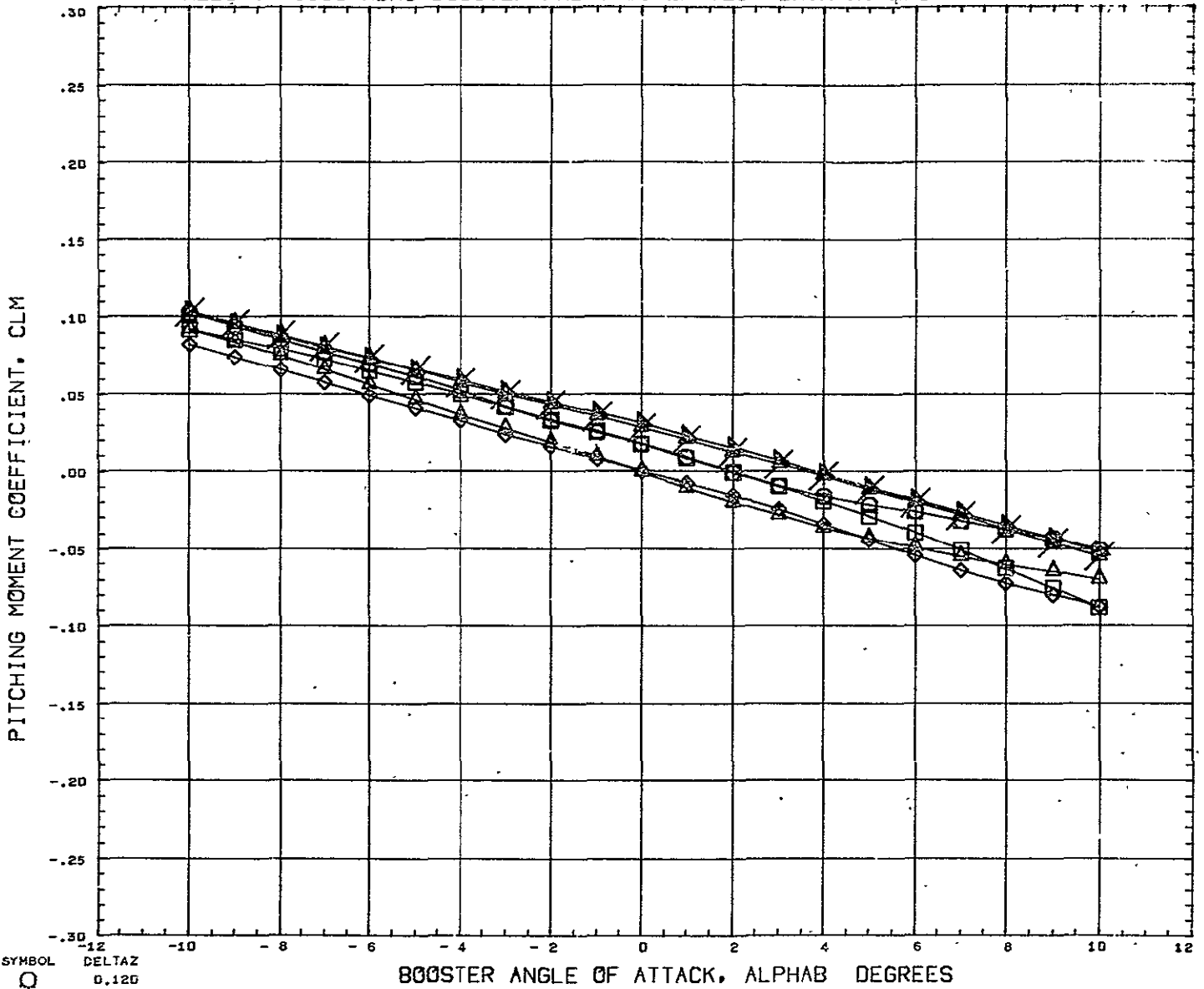

SYMBOL	DELTA Z	PARAMETRIC VALUES				REFERENCE INFORMATION		
◇	0.120	0.000	ORBPOW	0.000	REFS	23.6890	SQ IN'	
◇	0.151	0.228	ALPHA I	- 4.900	REFL	4.1930	IN	
◇	0.182	DELTA X	0.228	ALPHA I	- 4.900	REFB	6.5000	IN
◇	0.228	MACH	5.010	ELVBST	0.000	XMRP	4.9170	IN
◇	0.352	ELVORB	0.000	BETA	0.000	YMRP	0.0000	IN
◇	10.000					ZMRP	1.3900	IN
						SCALE	0.0055	

# AEDC VA 1163 MDAC BOOSTER AND ORBITER TEST DATA AT MACH NUMBER 5

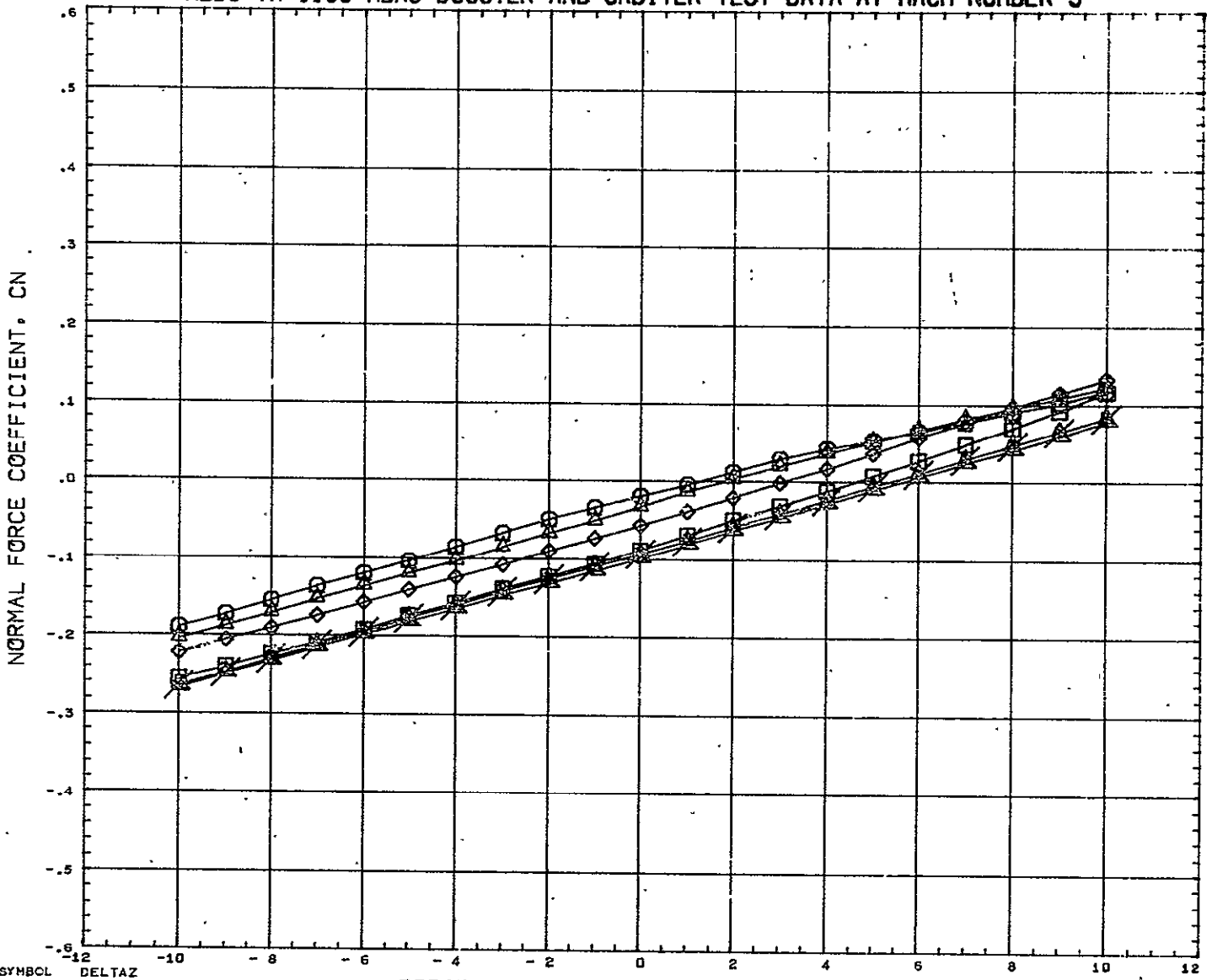

SYMBOL ○ □ ◇ △ ▲	DELTAZ 0.120 0.151 0.162 0.220 0.352 10.000	PARAMETRIC VALUES JSTPOW 0.000 ORBPOW 0.000 DELTAX 0.220 ALPHAI 4.900 MACH 5.010 ELVBST 0.000 ELVORB 0.000 BETA 0.000	REFERENCE INFORMATION REFS 23.6890 SQ IN REFL 4.1930 IN REFB 6.5000 IN XMRF 4.9170 IN YMRP 0.0000 IN ZMRP 1.3900 IN SCALE 0.0055
---------------------------------	---	---	---

REFERENCE FILE

# AEDC VA 1163 MDAC BOOSTER AND ORBITER TEST DATA AT MACH NUMBER 5

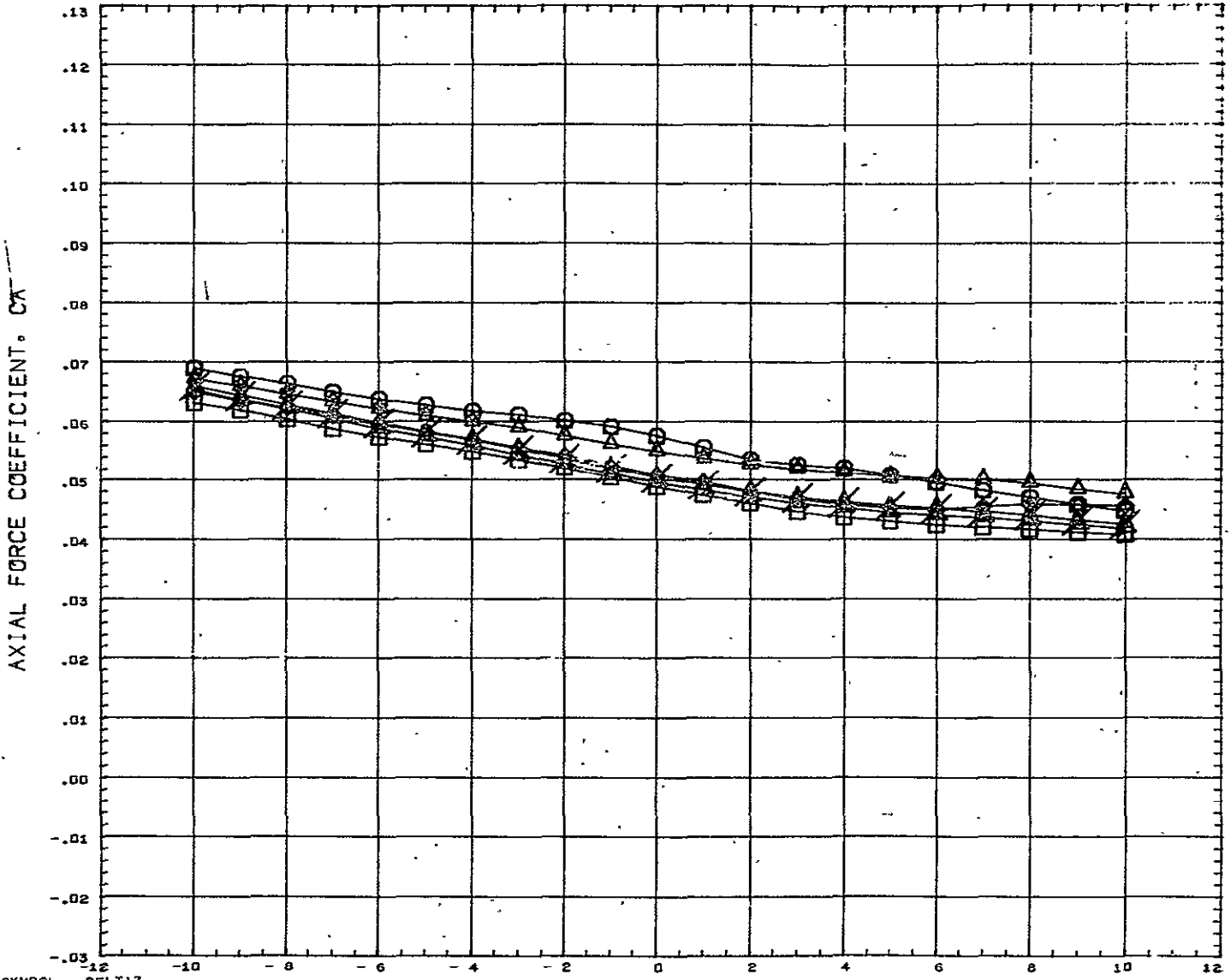

SYMBOL ○ ◇ □ △	DELTAZ 0.120 0.151 0.182 0.228 0.352 10.000	PARAMETRIC VALUES 3TPOW 0.000 ORBPOW 0.000 DELTAX 0.228 ALPHAI - 4.900 MACH 5.010 ELVBST 0.000 ELVORB 0.000 BETA 0.000	REFERENCE INFORMATION REFS 23.6890 SQ IN REFL 4.1930 IN REFB 6.5000 IN XMRF 4.9170 IN YMRF 0.0000 IN ZMRF 1.3900 IN SCALE 0.0055
----------------------------	---	--	---

REFERENCE FILE

# AEDC VA 1163 MDAC BOOSTER AND ORBITER TEST DATA AT MACH NUMBER 5

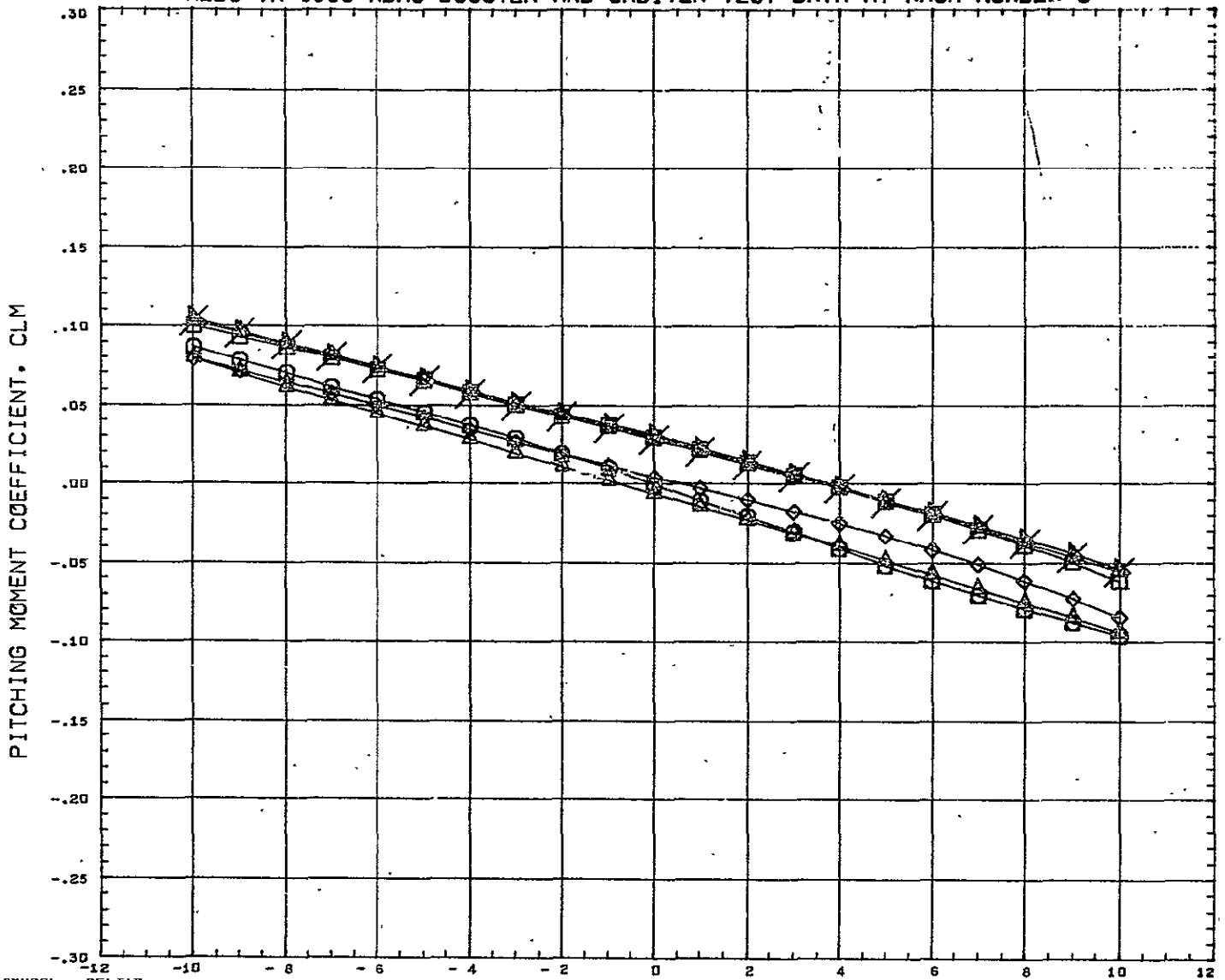

SYMBOL ○ ◇ □ △ ×	DELTA Z 0.120 0.151 0.182 0.228 0.352 10.000	PARAMETRIC VALUES BSTPOW 0.000 ORBPOW 0.000 DELTAX 0.352 ALPHAI - 4.900 MACH 5.010 ELVBST 0.000 ELVORB 0.000 BETA 0.003	REFERENCE INFORMATION REFS 23.6890 SQ IN REFL 4.1930 IN REFB 6.5000 IN YMRP 4.9175 IN YMRP 0.0000 IN ZMRP 1.3900 IN SCALE 0.0055
REFERENCE FILE			

# AEDC VA 1163 MDAC BOOSTER AND ORBITER TEST DATA AT MACH NUMBER 5

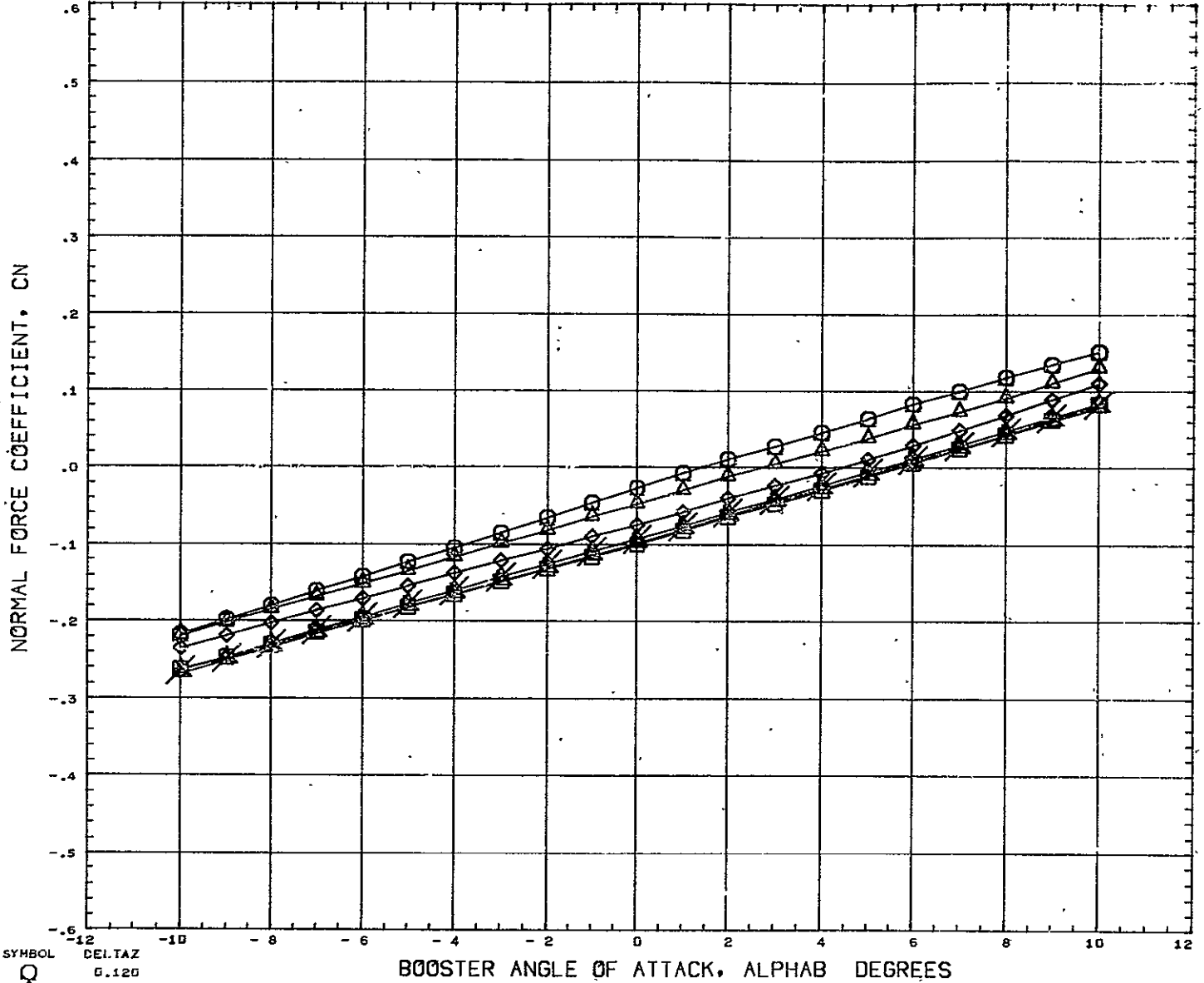

SYMBOL	DELTA Z
○	0.120
◇	0.151
◻	0.182
◻	0.226
△	0.352
×	10.000

PARAMETRIC VALUES			
BSTPOW	0.000	ORBPOW	0.000
JELTAX	0.352	ALPHAI	-4.900
MACH	5.010	ELVBST	0.000
ELVORB	0.000	BETA	0.000

REFERENCE INFORMATION		
REFS	23.6890	SQ IN
REFL	4.1930	IN
REFB	6.5000	IN
XMRP	4.9170	IN
YMRF	0.0000	IN
ZMRF	1.3900	IN
SCALE	0.0055	

REFERENCE FILE

# AEDC VA 1163 MDAC BOOSTER AND ORBITER TEST DATA AT MACH NUMBER 5

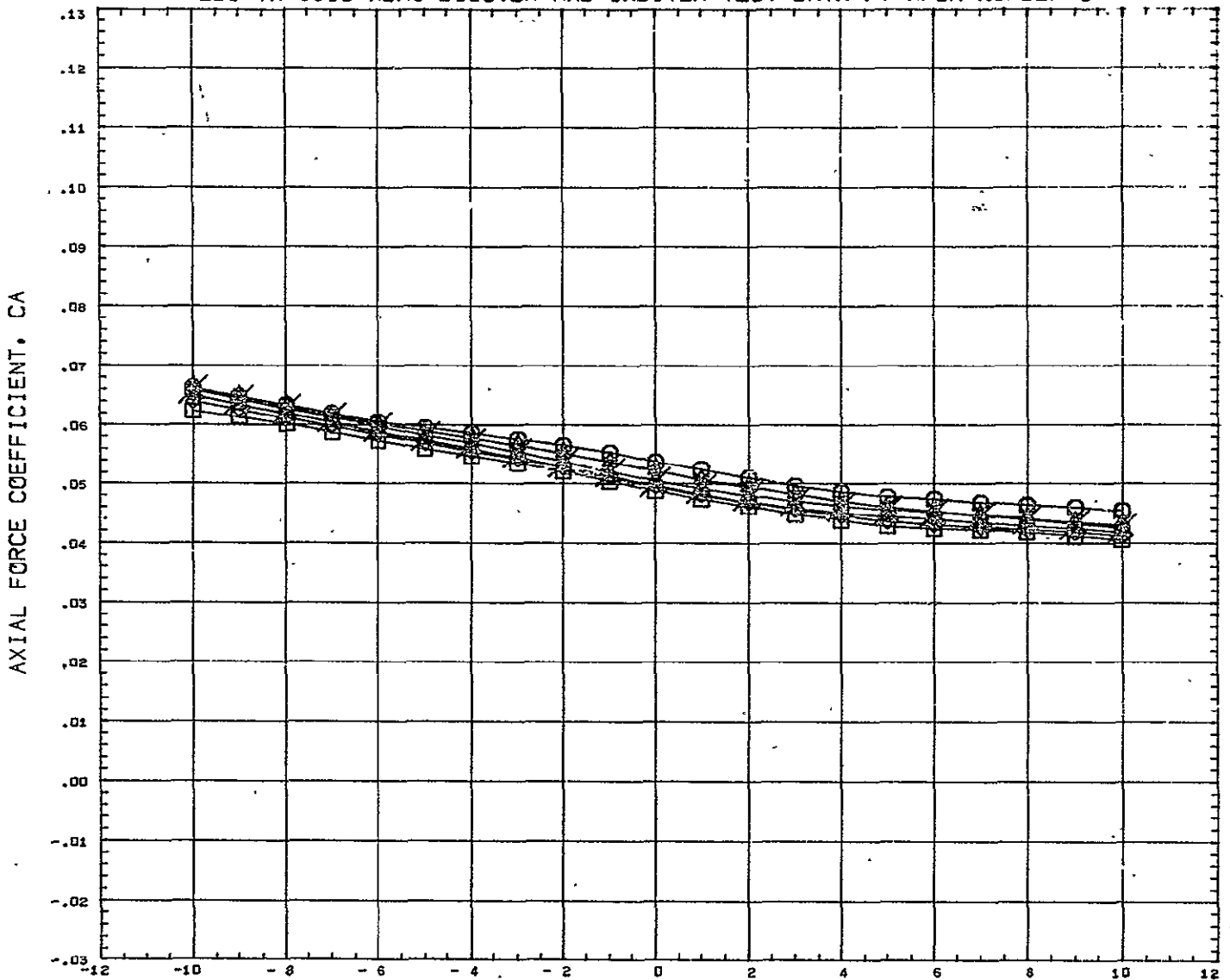

SYMBOL	DELTA Z	PARAMETRIC VALUES				REFERENCE INFORMATION		
○	0.120	RSTFOW	0.000	ORBPOW	0.000	REFS	23.6690	SQ IN
◇	0.151	DELTA X	0.352	ALPHA I	-4.900	REFL	4.1930	IN
□	0.182	MACH	5.010	ELVBST	0.000	REFB	6.5000	IN
△	0.228	ELVORB	0.000	BETA	0.000	XNRP	4.9170	IN
▽	0.352					YNRP	0.0000	IN
○	10.000					ZNRP	1.3900	IN
						SCALE	0.0055	

REFERENCE FILE

# AEDC VA 1163 MDAC BOOSTER AND ORBITER TEST DATA AT MACH NUMBER 5

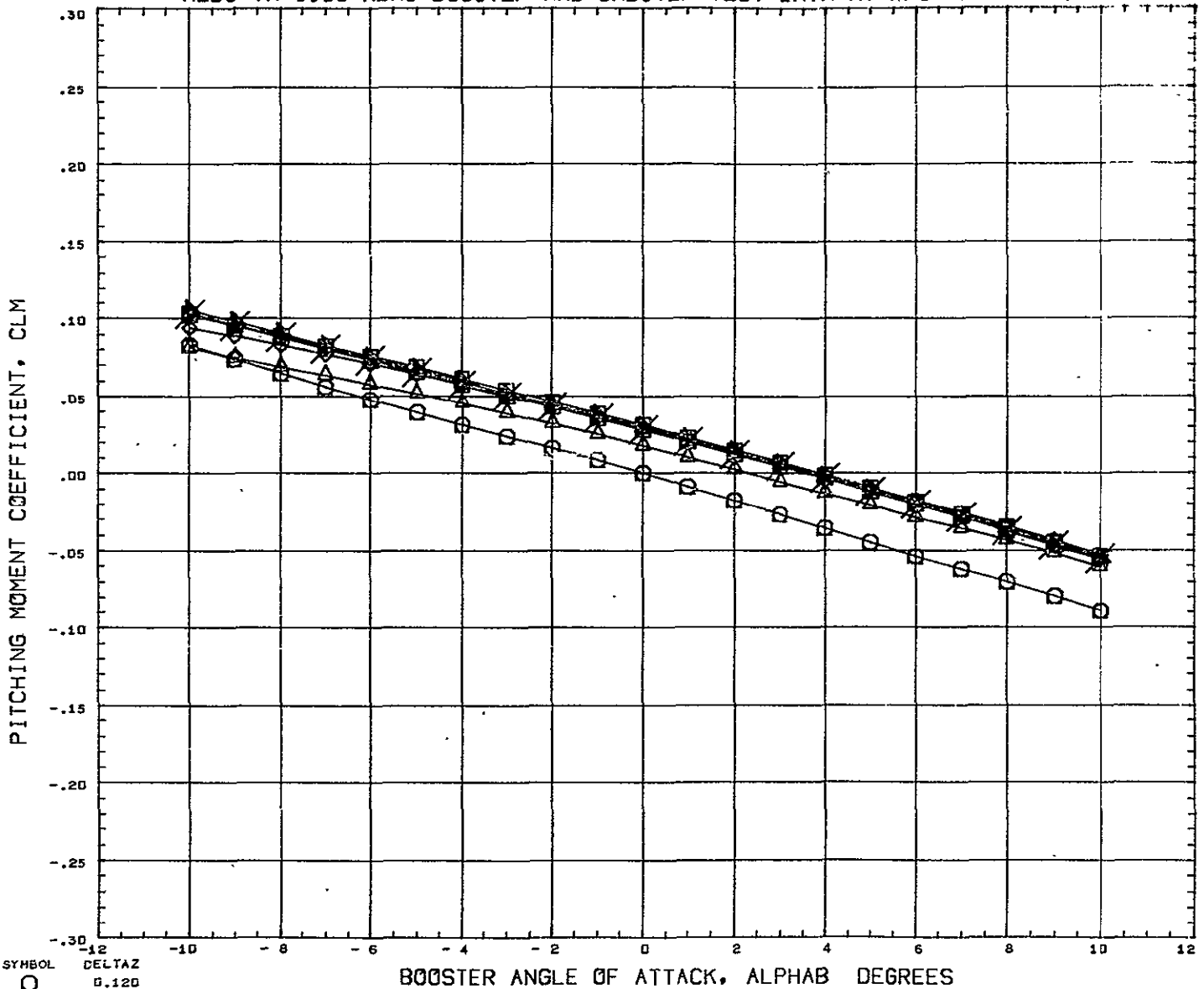

SYMBOL ○ □ △ ◇ ×	DELTAZ 0.120 0.151 0.182 0.228 0.352 0.559 10.000	<b>PARAMETRIC VALUES</b> BSTPOW 0.000 ORBPOW 0.000 DELTAX 0.522 ALPHAI - 4.900 MACH 5.010 ELVBST 0.000 ELVORB 0.000 BETA 0.000	<b>REFERENCE INFORMATION</b> REFS 23.6890 SQ IN REFL 4.1930 IN REFB 6.5000 IN XMRF 4.9179 IN YMRF 0.0000 IN ZMRF 1.3900 IN SCALE 0.0055
REFERENCE FILE			



# AEDC VA 1163 MDAC BOOSTER AND ORBITER TEST DATA AT MACH NUMBER 5

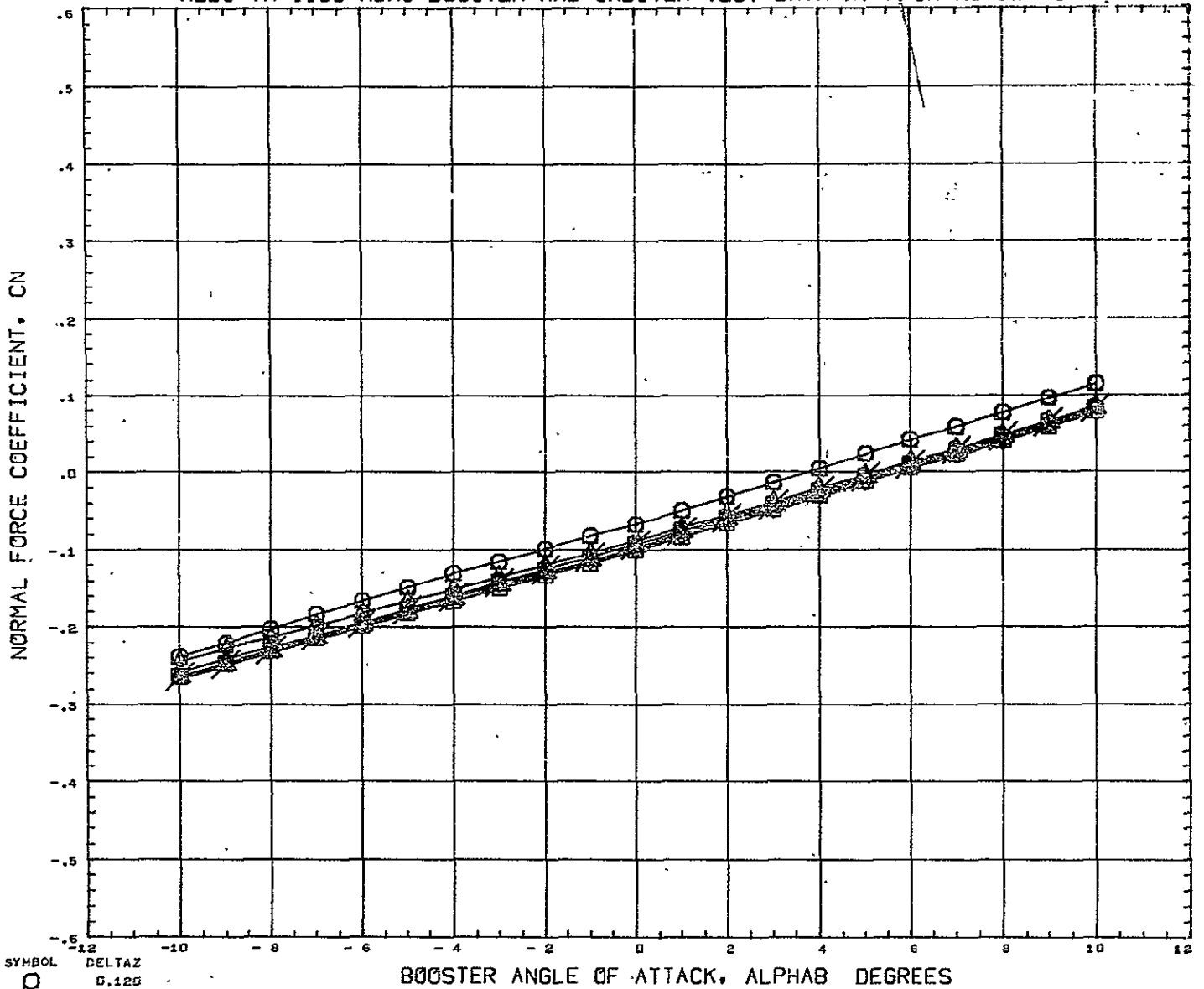

SYMBOL

DELTA Z  
 0.120  
 0.151  
 0.182  
 0.228  
 0.352  
 0.599  
 10.000

PARAMETRIC VALUES  
 BSTFOW 0.000 ORBPOW 0.000  
 DELTAX 0.522 ALPHA1 - 4.900  
 MACH 5.010 ELVBST 0.000  
 ELVORB 0.000 BETA 0.000

REFERENCE INFORMATION  
 REFS 23.6890 SQ IN  
 REFL 4.1930 IN  
 REFB 6.5000 IN  
 XMRF 4.9170 IN  
 YMRF 0.0000 IN  
 ZMRF 1.3900 IN  
 SCALE 0.0055

REFERENCE FILE

# AEDC VA 1163 MDAC BOOSTER AND ORBITER TEST DATA AT MACH NUMBER 5

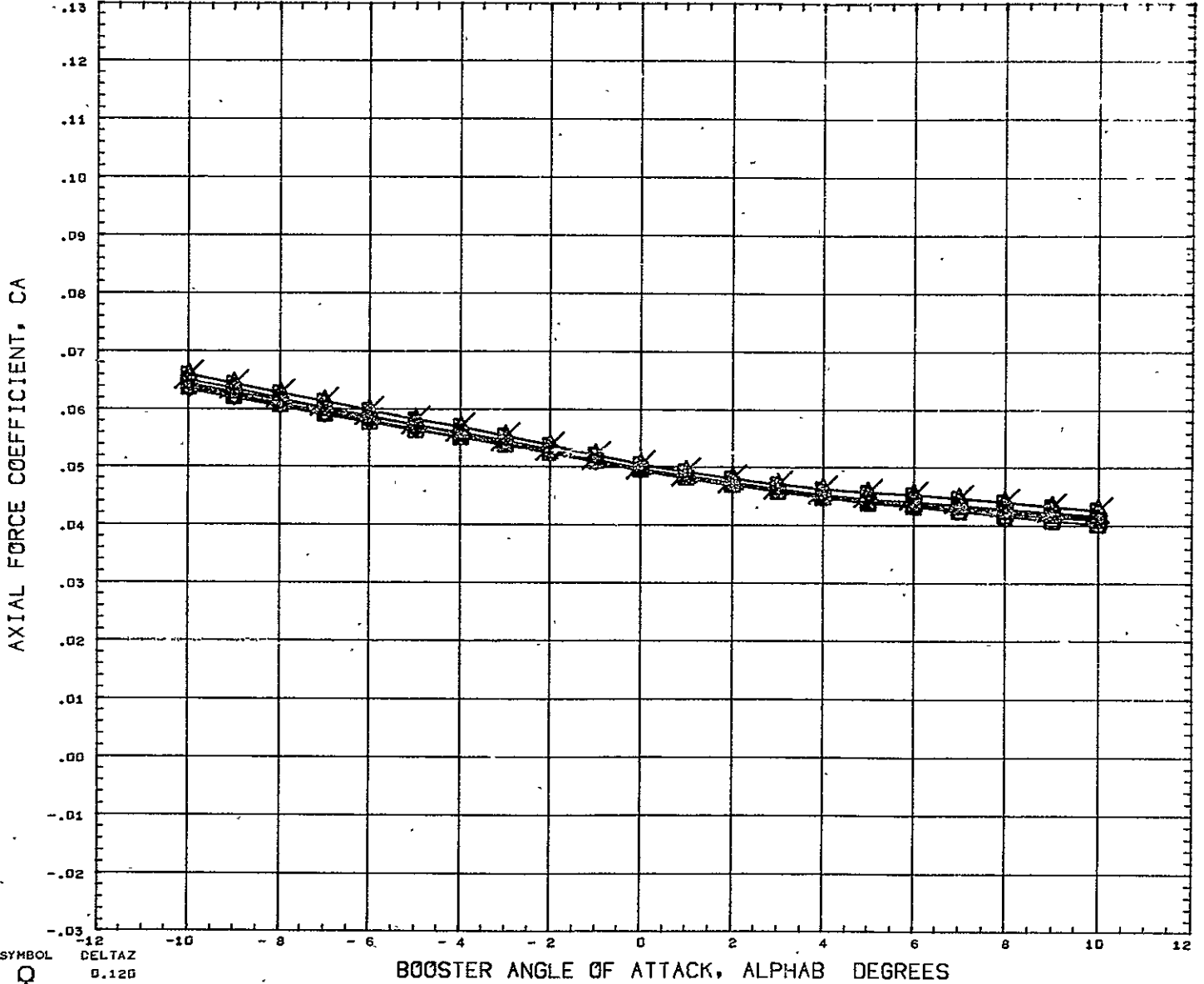

SYMBOL 	<table border="0"> <tr><td>DELTAZ</td><td>0.120</td></tr> <tr><td></td><td>0.151</td></tr> <tr><td>0.182</td><td>BSTPOW 0.000</td></tr> <tr><td>0.228</td><td>DELTAZ 0.522</td></tr> <tr><td>0.352</td><td>MACH 5.010</td></tr> <tr><td>0.599</td><td>ELVORB 0.000</td></tr> <tr><td>10.000</td><td></td></tr> </table>	DELTAZ	0.120		0.151	0.182	BSTPOW 0.000	0.228	DELTAZ 0.522	0.352	MACH 5.010	0.599	ELVORB 0.000	10.000		<b>BOOSTER ANGLE OF ATTACK, ALPHA DEGREES</b>  <table border="0"> <tr><th colspan="4">PARAMETRIC VALUES</th></tr> <tr><td>ORBPOW</td><td>0.000</td><td>ALPHA1</td><td>-4.900</td></tr> <tr><td>ELVBST</td><td>0.000</td><td>BETA</td><td>0.000</td></tr> </table>	PARAMETRIC VALUES				ORBPOW	0.000	ALPHA1	-4.900	ELVBST	0.000	BETA	0.000	<table border="0"> <tr><th colspan="3">REFERENCE INFORMATION</th></tr> <tr><td>REFS</td><td>23.6690</td><td>SQ IN</td></tr> <tr><td>REFL</td><td>4.1930</td><td>IN</td></tr> <tr><td>REFB</td><td>6.5000</td><td>IN</td></tr> <tr><td>XMRP</td><td>4.9170</td><td>IN</td></tr> <tr><td>YMRP</td><td>0.0000</td><td>IN</td></tr> <tr><td>ZMRP</td><td>1.3900</td><td>IN</td></tr> <tr><td>SCALE</td><td>0.0055</td><td></td></tr> </table>	REFERENCE INFORMATION			REFS	23.6690	SQ IN	REFL	4.1930	IN	REFB	6.5000	IN	XMRP	4.9170	IN	YMRP	0.0000	IN	ZMRP	1.3900	IN	SCALE	0.0055	
DELTAZ	0.120																																																				
	0.151																																																				
0.182	BSTPOW 0.000																																																				
0.228	DELTAZ 0.522																																																				
0.352	MACH 5.010																																																				
0.599	ELVORB 0.000																																																				
10.000																																																					
PARAMETRIC VALUES																																																					
ORBPOW	0.000	ALPHA1	-4.900																																																		
ELVBST	0.000	BETA	0.000																																																		
REFERENCE INFORMATION																																																					
REFS	23.6690	SQ IN																																																			
REFL	4.1930	IN																																																			
REFB	6.5000	IN																																																			
XMRP	4.9170	IN																																																			
YMRP	0.0000	IN																																																			
ZMRP	1.3900	IN																																																			
SCALE	0.0055																																																				
	REFERENCE FILE																																																				

# AEDC VA 1163 MDAC BOOSTER AND ORBITER TEST DATA AT MACH NUMBER 5

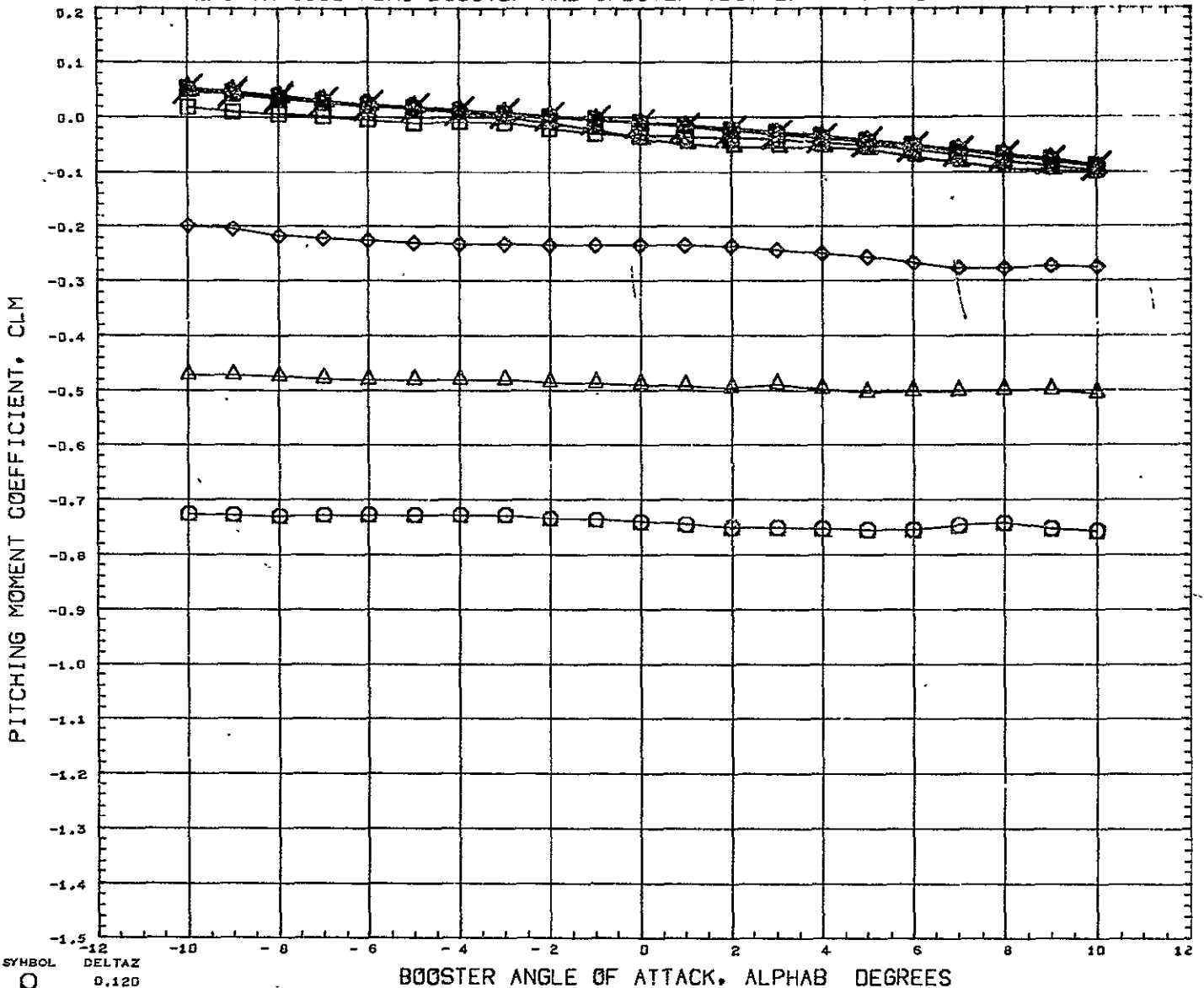

SYMBOL □ ◇ △ ○ ×	DELTAX 0.120 0.151 0.182 0.228 0.352 0.599 0.908 10.000	PARAMETRIC VALUES BSTPOW 50.000 ORBPOW 100.000 DELTAX - 0.391 ALPHAI 0.000 MACH 5.010 ELVBST 0.000 ELVORB 0.000 BETA 0.000	REFERENCE INFORMATION REFS 23.6890 S2 IN REFL 4.1930 IN REFB 6.5000 IN XMRP 4.9170 IN YMRP 0.0000 IN ZMRP 1.3900 IN SCALE 0.0055
	BOOSTER ANGLE OF ATTACK, ALPHAB DEGREES		

# AEDC VA 1163 MDAC BOOSTER AND ORBITER TEST DATA AT MACH NUMBER 5

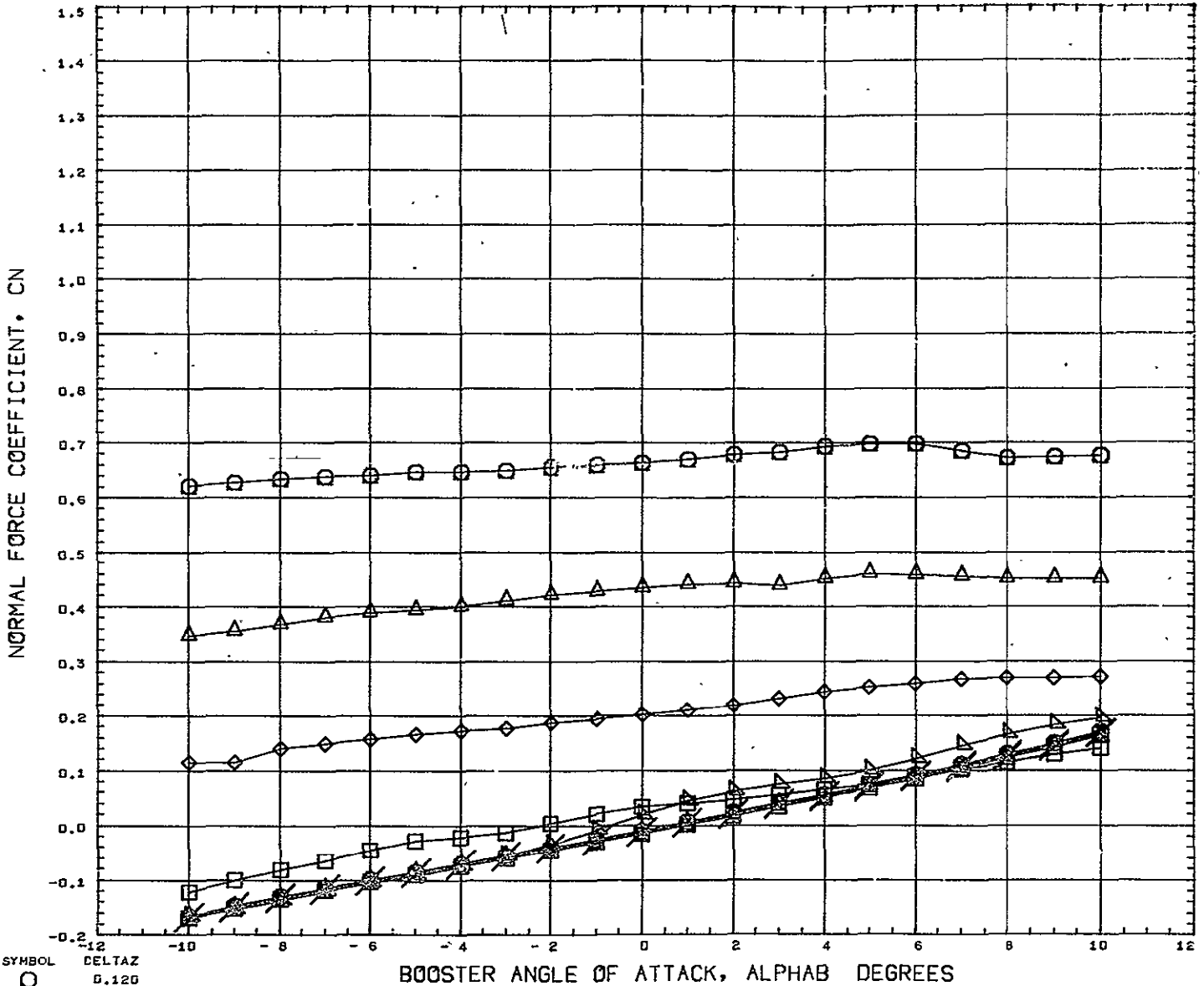

SYMBOL ○ △ ◇ □ × 10.000	DELTAZ 0.120 0.151 0.182 0.228 0.352 0.599 0.908 10.000	PARAMETRIC VALUES BSTPOW 50.000 ORBPOW 100.000 DELTAX - 0.391 ALPHAI 0.000 MACH 5.010 ELVBST 0.000 ELVORB 0.000 BETA 0.000 REFERENCE FILE //	REFERENCE INFORMATION REFS 23.6890 SQ IN REFL 4.1930 IN REFB 6.5000 IN XMRF 4.9170 IN YMRF 0.0000 IN ZMRF 1.3900 IN SCALE 0.0055
---	---	---	---

# AEDC VA 1163 MDAC BOOSTER AND ORBITER TEST DATA AT MACH NUMBER 5

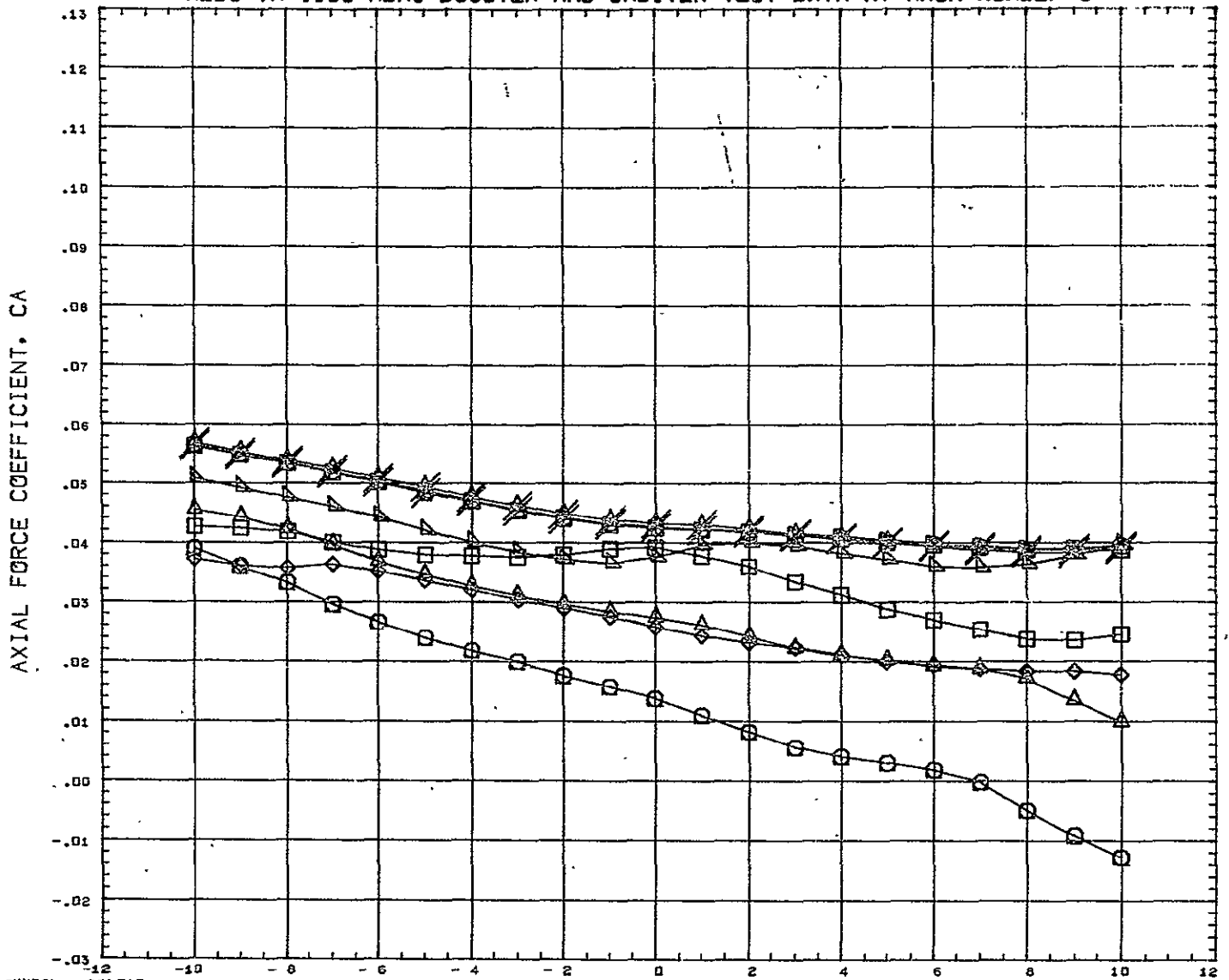

SYMBOL	DELTA Z		PARAMETRIC VALUES		REFERENCE INFORMATION
○	0.120				REFS 23.6890 SQ IN
◇	0.151				REFL 4.1930 IN
□	0.182	BSTFOW 50.000	ORBPOW 100.000		REFB 6.5000 IN
△	0.228	DELTA X - 0.391	ALPHA I 0.000		XMRP 4.9170 IN
◇	0.352	MACH 5.010	ELVBST 0.000		YMRF 0.0000 IN
○	0.599	ELVORB 0.000	BETA 0.000		ZMRP 1.3900 IN
◇	0.908				SCALE 0.0055
X	10.000	REFERENCE FILE			

# AEDC VA 1163 MDAC BOOSTER AND ORBITER TEST DATA AT MACH NUMBER 5

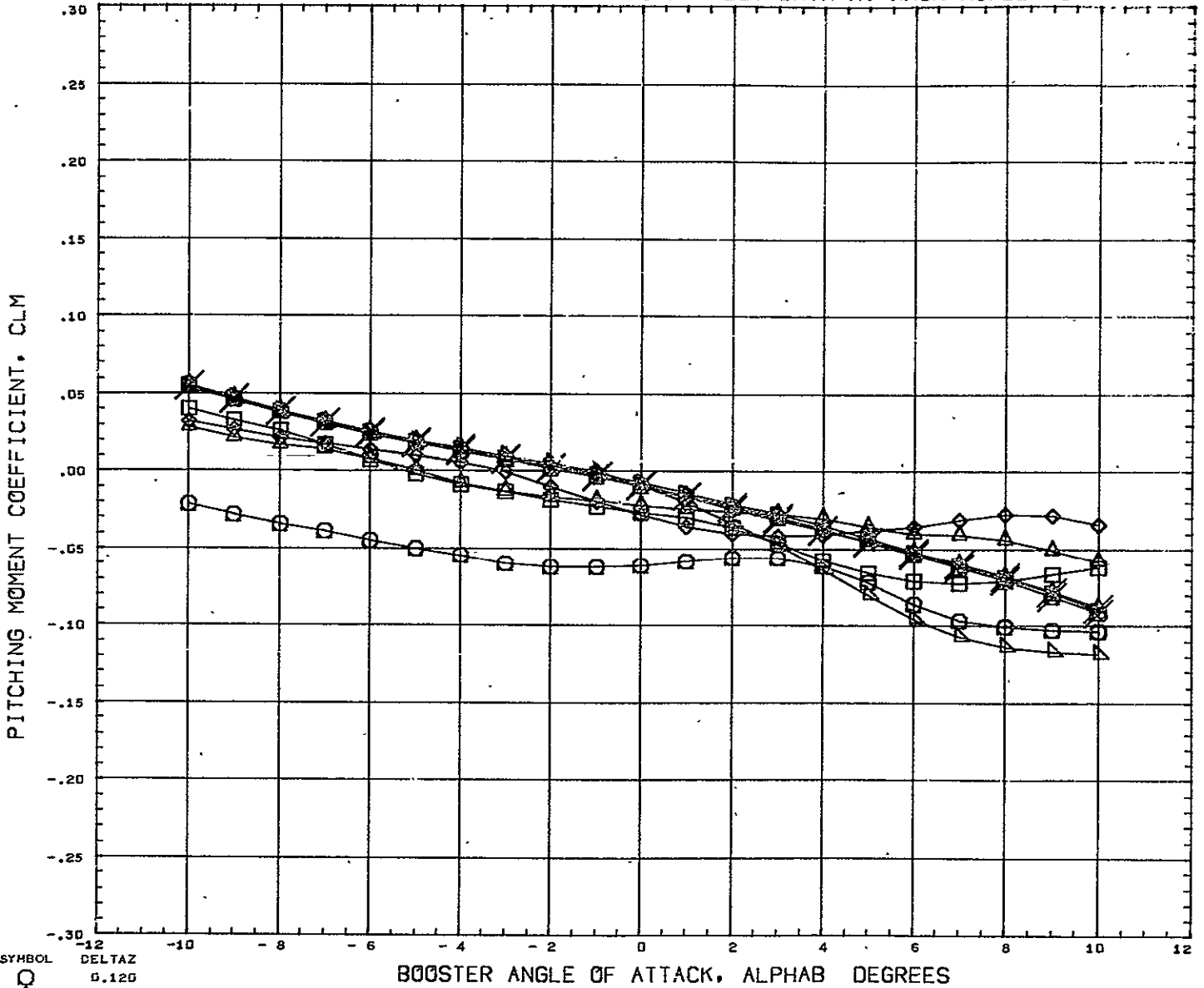

SYMBOL <del>○</del> <del>□</del> <del>△</del> <del>◇</del> <del>×</del>	DELTAZ 0.120 0.151 0.182 0.228 0.352 0.599 0.908 10.000	PARAMETRIC VALUES BSTFOW 50.000 ORBFOV 100.000 DELTAX - 0.143 ALPHAI 0.000 MACH 5.010 ELVBST 0.000 ELVORB 0.000 BETA 0.03C REFERENCE FILE	REFERENCE INFORMATION REFS 23.6890 SQ IN REFL 4.1930 IN REFB 6.5000 IN XMRP 4.9170 IN YMRP 0.0000 IN ZMRP 1.3900 IN SCALE 0.0055
--	---	--	---

# AEDC VA 1163 MDAC BOOSTER AND ORBITER TEST DATA AT MACH NUMBER 5

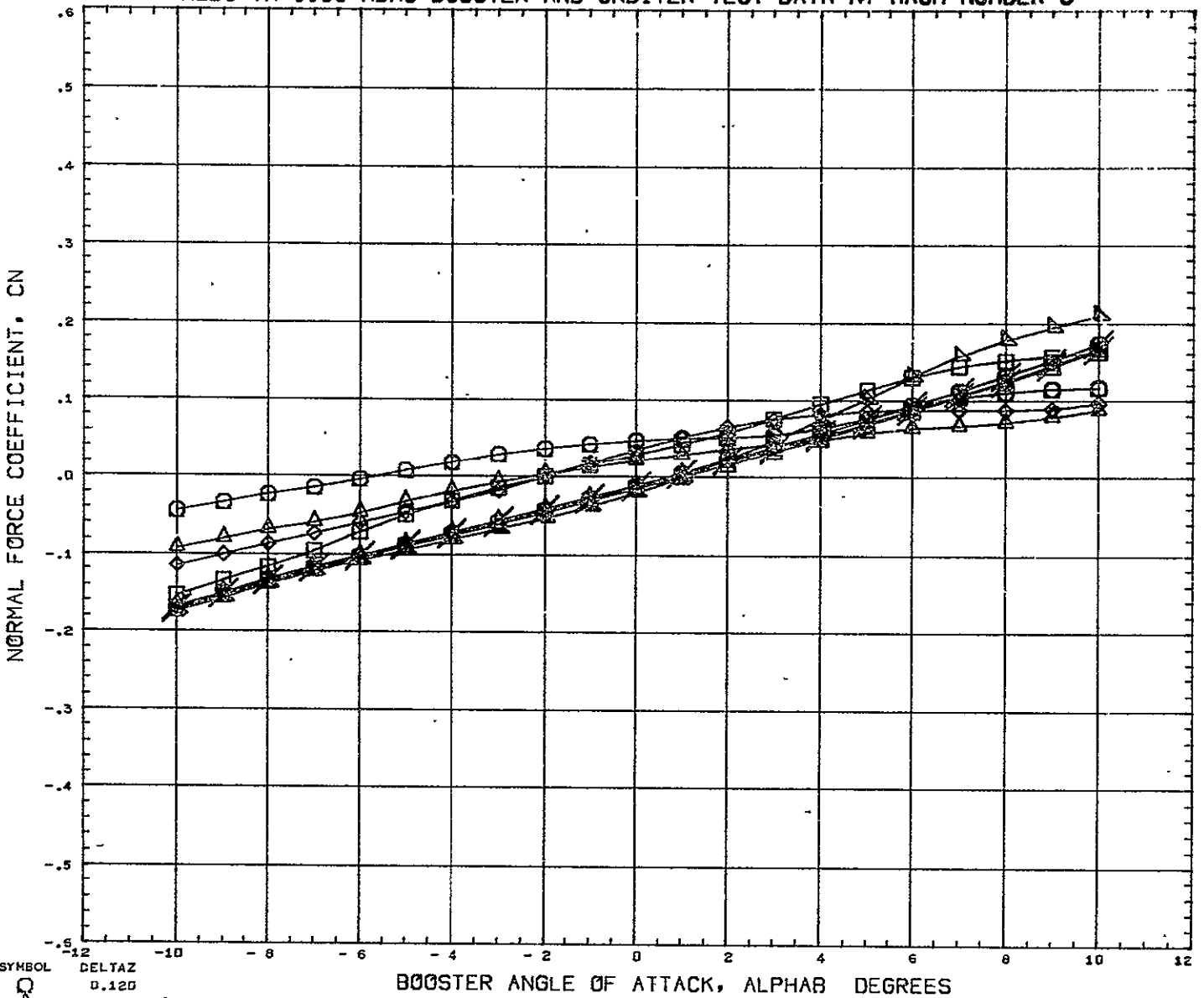

SYMBOL	DELTAZ 0.120 0.151 0.182 0.228 0.352 0.599 0.908 10.000	PARAMETRIC VALUES BSTPOW 50.000 ORBPOW 100.000 DELTAZ - 0.143 ALPHAI 0.000 MACH 5.010 ELVBST 0.000 ELVORB 0.000 BETA 0.000	REFERENCE INFORMATION REFS 23.6890 SQ IN REFL 4.1930 IN REFB 6.5000 IN XMRP 4.9170 IN YMRP 0.0000 IN ZMRP 1.3900 IN SCALE 0.0055
10.000 REFERENCE FILE			





# AEDC VA 1163 MDAC BOOSTER AND ORBITER TEST DATA AT MACH NUMBER 5

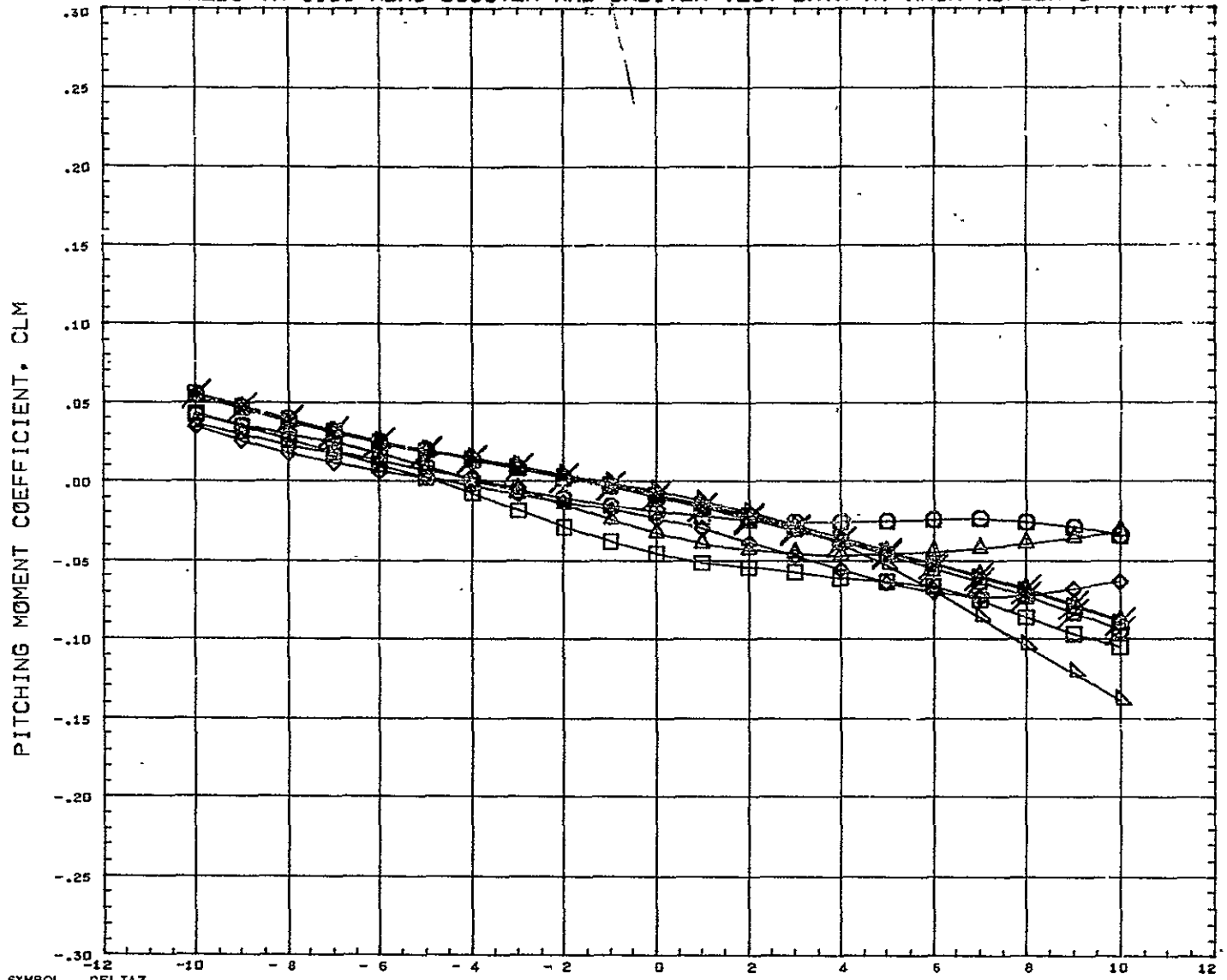

SYMBOL	DELTAZ	PARAMETRIC VALUES				REFERENCE INFORMATION		
○	0.120							
◇	0.151							
○	0.182	BSTPOW	50.000	ORBPOW	100.000	REFS	23.6890	SQ IN
◇	0.228	DELTAZ	- 0.019	ALPHA1	0.000	REFL	4.1930	IN
○	0.352	MACH	5.010	ELVBST	0.000	REFB	6.5000	IN
◇	0.599	ELVORB	0.000	BETA	0.600	XMRP	4.9170	IN
○	0.908					YMRP	0.0000	IN
◇	10.000	REFERENCE FILE				ZMRP	1.3900	IN
						SCALE	0.0055	

# AEDC VA 1163 MDAC BOOSTER AND ORBITER TEST DATA AT MACH NUMBER 5

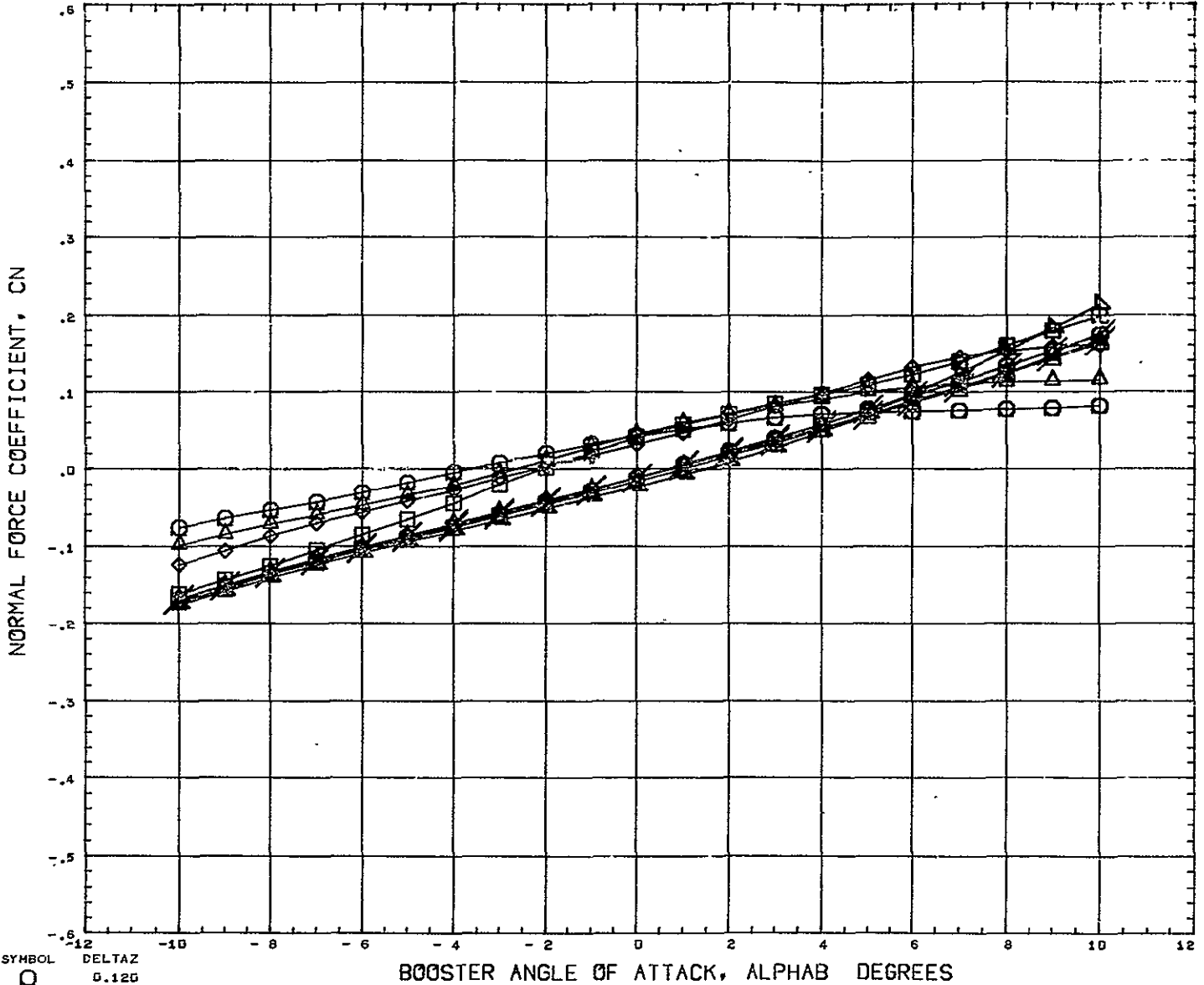

SYMBOL

DELTAZ

BOOSTER ANGLE OF ATTACK, ALPHAB DEGREES

REFERENCE INFORMATION

0.125			
0.151			
0.182	BSTPOW	50.000	ORBPOW 100.000
0.228	DELTAZ	0.019	ALPHA1 0.000
0.352	MACH	5.010	ELVBST 0.000
0.599	ELVORB	0.000	BETA 0.000
0.908			
10.000	REFERENCE FILE		

REFS	23.6890	SQ IN
REFL	4.1930	IN
REFB	6.5000	IN
XMRP	4.0170	IN
YMRP	0.0000	IN
ZMRP	1.3900	IN
SCALE	0.0055	

# AEDC VA 1163 MDAC BOOSTER AND ORBITER TEST DATA AT MACH NUMBER 5

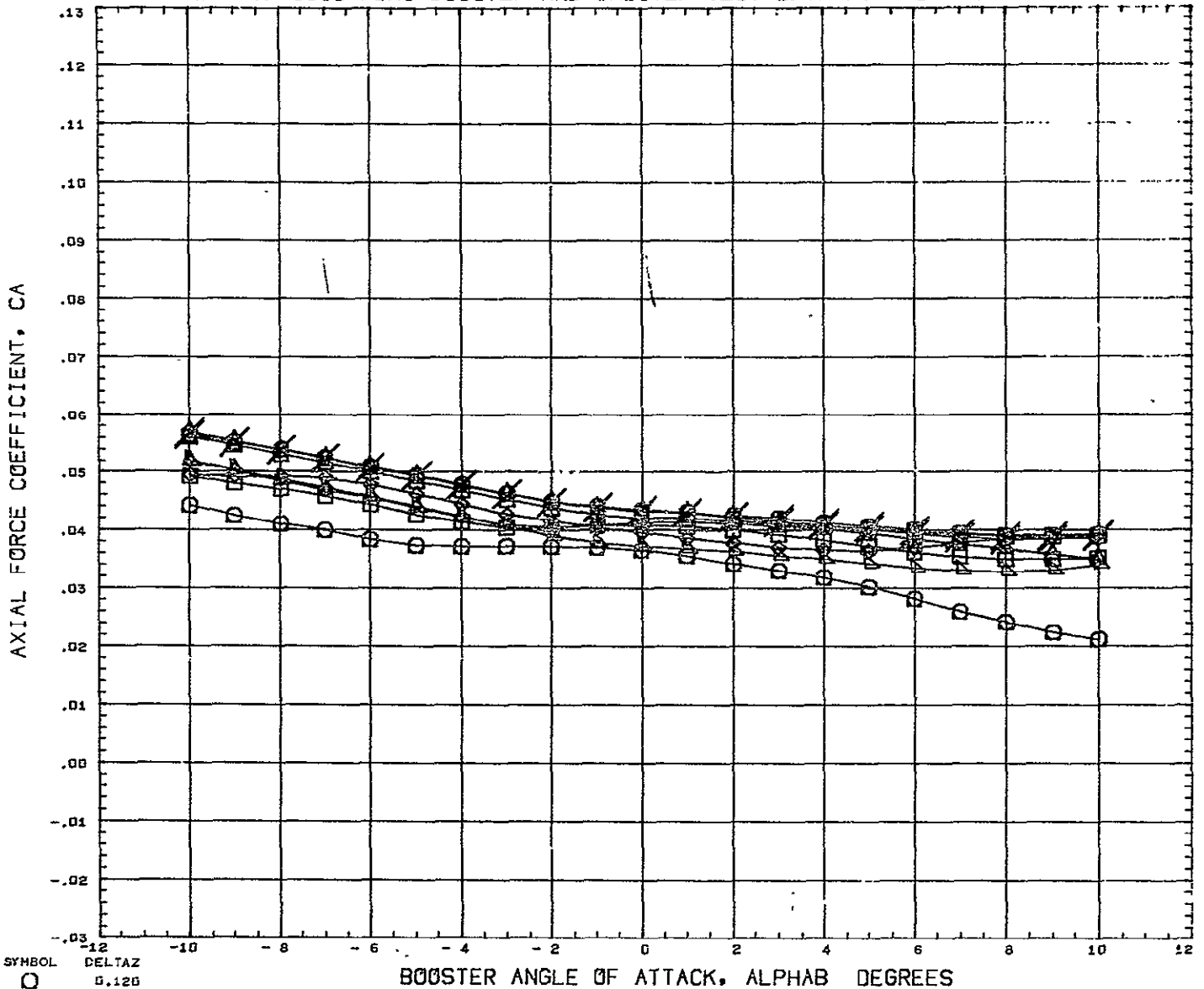

SYMBOL	DELTA Z	PARAMETRIC VALUES				REFERENCE INFORMATION		
○	0.120							
□	0.151							
◇	0.182	BSTPOW	50.000	ORBPOW	100.000	REFS	23.6890	50 IN
△	0.228	DELTA X	- 0.019	ALPHA I	0.000	REFL	4.1930	IN
▽	0.352	MACH	5.010	ELVBST	0.000	REFB	6.5000	IN
◇	0.599	ELVORB	0.000	BETA	0.000	XMRF	4.9170	IN
○	0.900					YMRF	0.0000	IN
△	10.000	REFERENCE FILE				ZMRF	1.3900	IN
						SCALE	0.0055	

# AEDC VA 1163 MDAC BOOSTER AND ORBITER TEST DATA AT MACH NUMBER 5

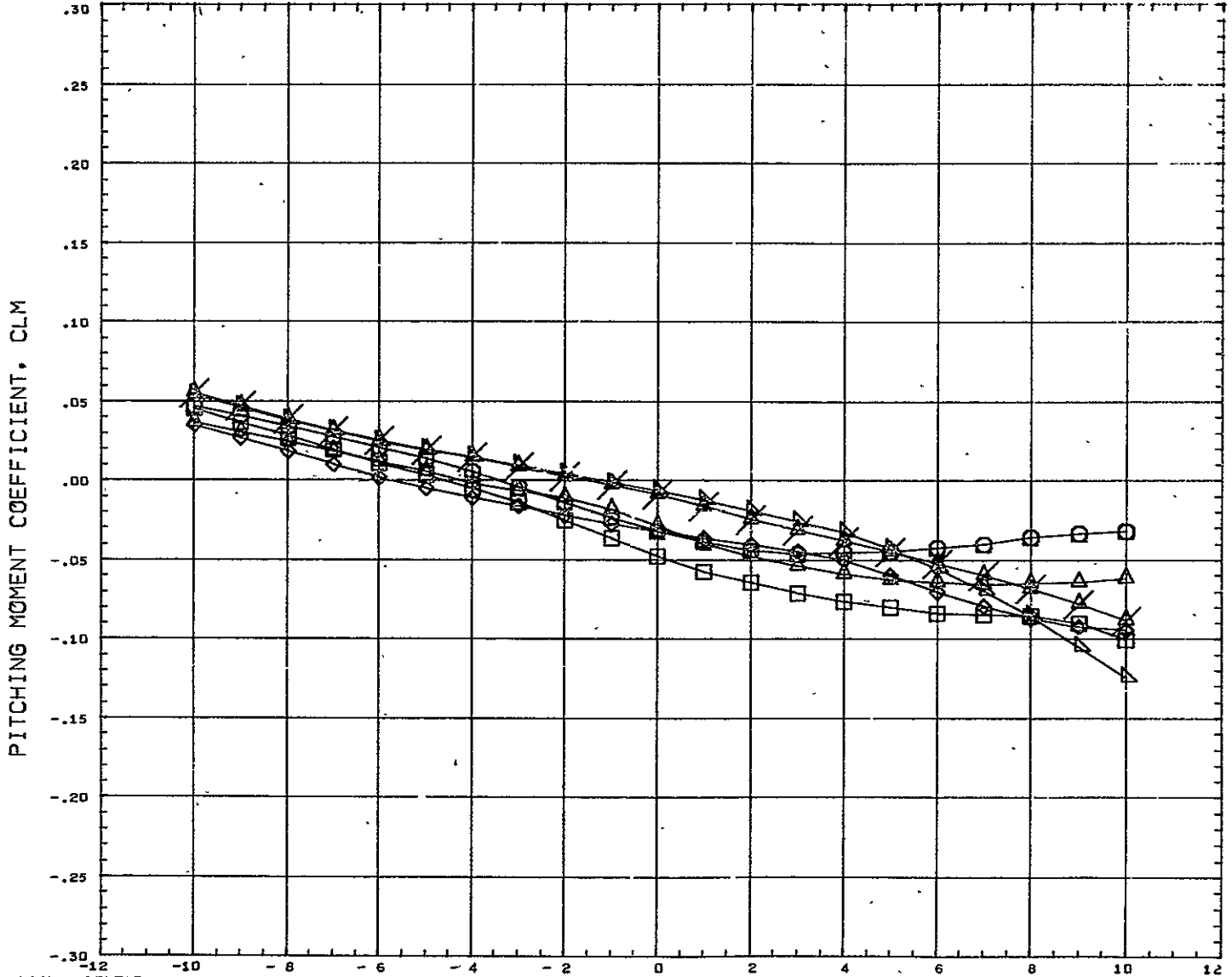

SYMBOL ○ □ △ ◇ ×	DELTAZ 0.120 0.151 0.182 0.228 0.352 10.000	PARAMETRIC VALUES BSTFOW 50.000 ORBPOW 100.000 DELTAX 0.042 ALPHAI 0.000 MACH 5.010 ELVBST 0.000 ELVORB 0.000 BETA 0.000	REFERENCE INFORMATION REFS 23.6890 SQ IN REFL 4.1930 IN REFB 6.5000 IN XMRF 4.9170 IN YMRP 0.0000 IN ZMRP 1.3900 IN SCALE 0.0055
---------------------------------	---	--	---

REFERENCE FILE

AEDC VA 1163 MDAC BOOSTER AND ORBITER TEST DATA AT MACH NUMBER 5

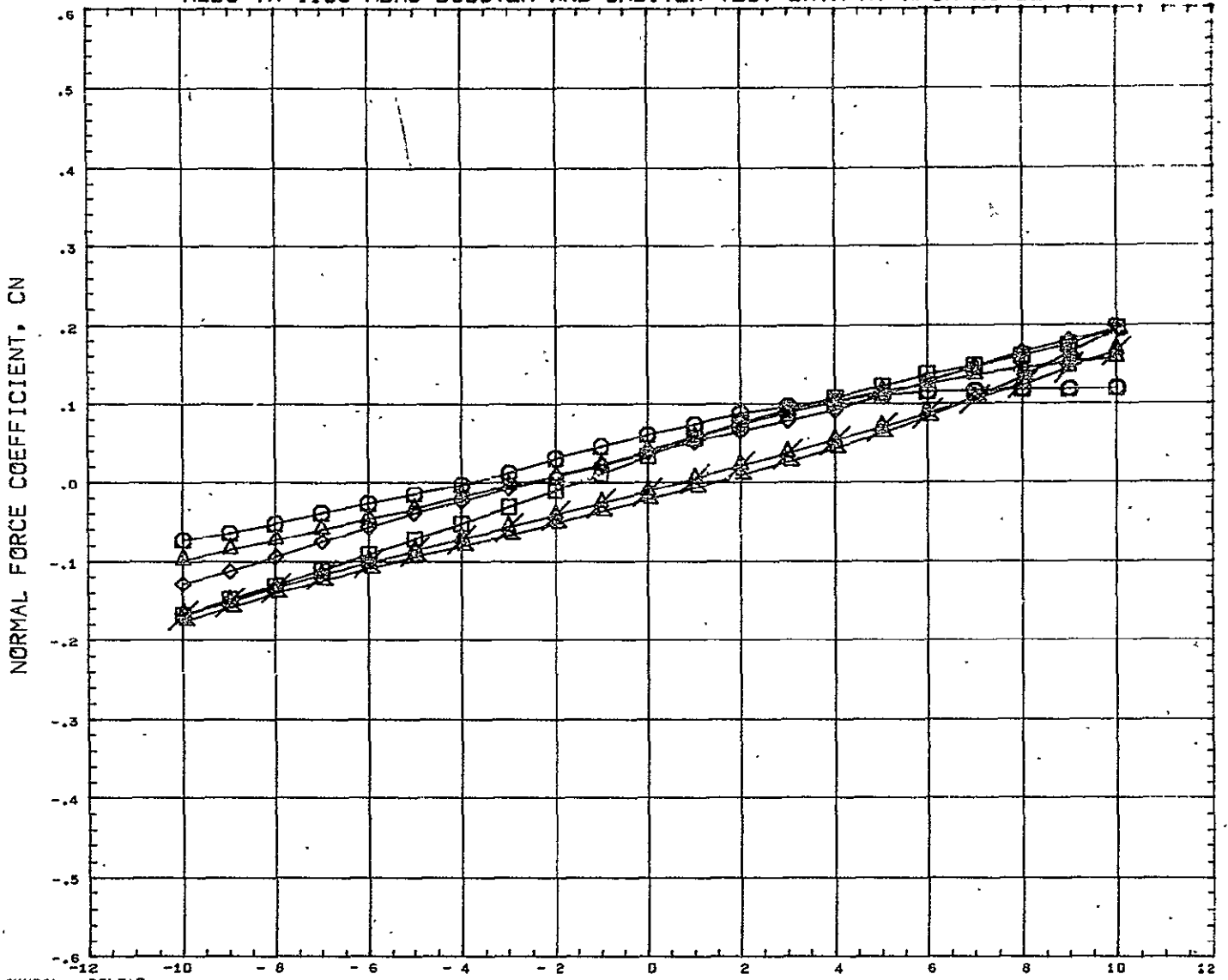

SYMBOL	DELTA Z	PARAMETRIC VALUES				REFERENCE INFORMATION		
○	0.120							
◇	0.151							
□	0.182	BSTPOW	50.000	ORBPOW	100.000	REFS	23.6990	50 IN
△	0.228	DELTA X	0.042	ALPHA I	0.000	REFL	4.1930	IN
▽	0.352	MACH	5.010	ELVBST	0.000	REFB	6.5000	IN
×	10.000	ELVORB	0.000	BETA	0.000	XNRF	4.9170	IN
						YNRF	0.0000	IN
						ZNRF	1.3900	IN
						SCALE	0.0055	

REFERENCE FILE

# AEDC VA 1163 MDAC BOOSTER AND ORBITER TEST DATA AT MACH NUMBER 5

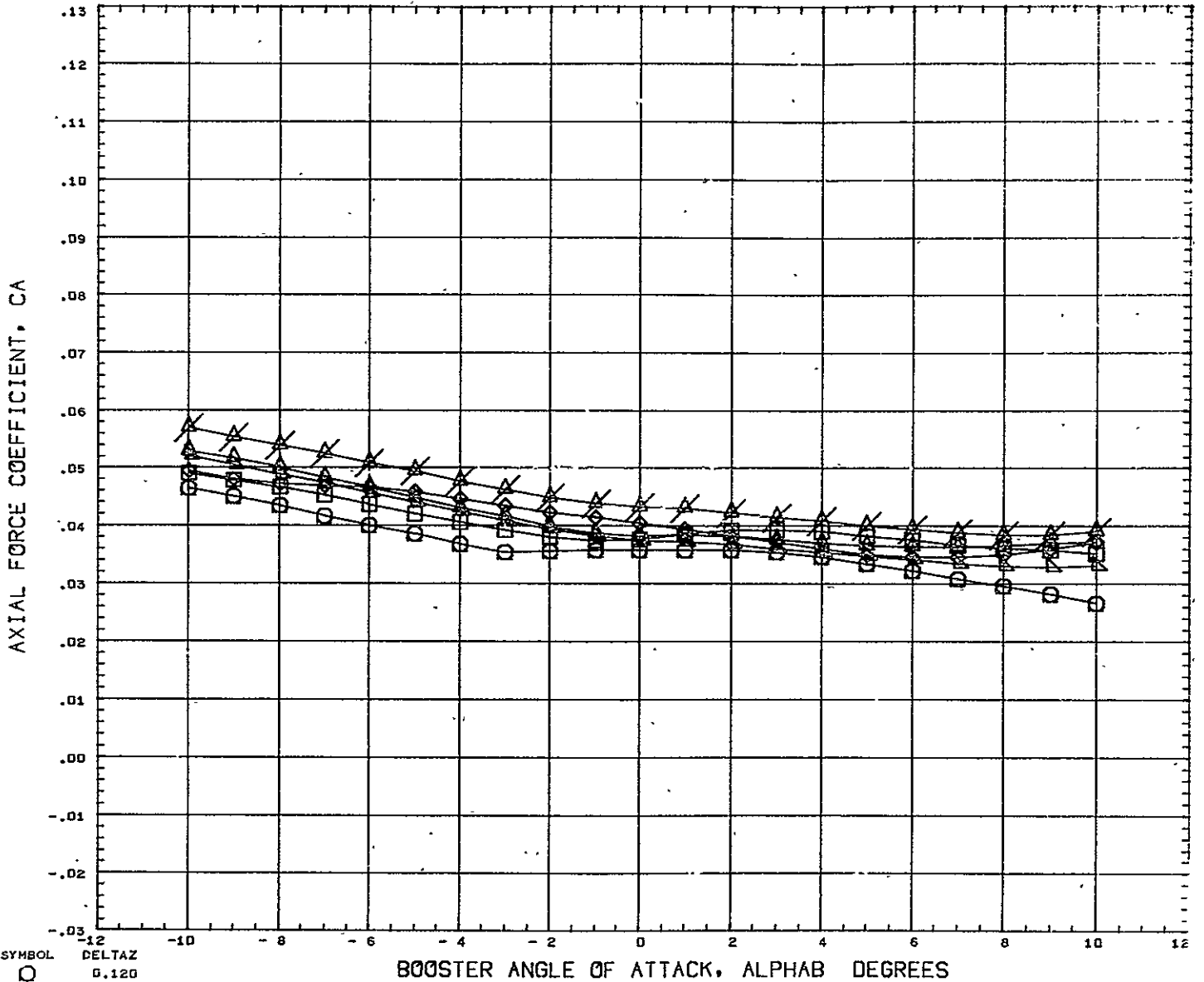

SYMBOL ○ ◊ □ △ ×	DELTAZ 0.120 0.151 0.182 0.228 0.352 10.000	PARAMETRIC VALUES BSTPOW 50.000 ORBPOW 100.000 DELTAX 0.042 ALPHAI 0.000 MACH 5.010 ELVBST 0.000 ELVORB 0.000 BETA -0.000	REFERENCE INFORMATION REFS 23.6890 SQ IN REFL 4.1930 IN REFB 6.5000 IN YMRP 4.9170 IN YMRP 0.0000 IN ZMRP 1.3900 IN SCALE 0.0055
---------------------------------	---	---	---

REFERENCE FILE

# AEDC VA 1163 MDAC BOOSTER AND ORBITER TEST DATA AT MACH NUMBER 5

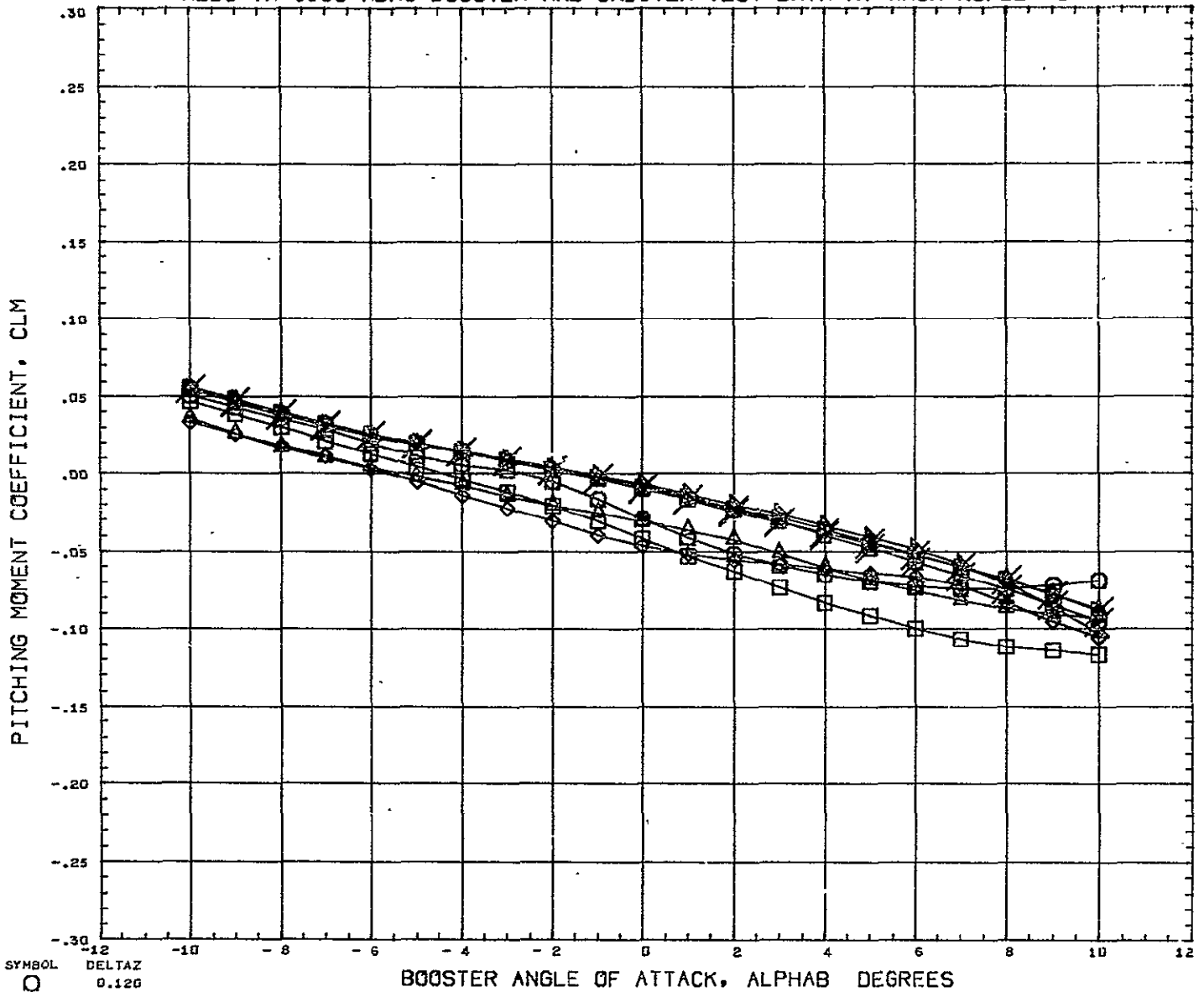

SYMBOL  
~~□~~  
~~◇~~  
~~△~~  
~~○~~

DELTAZ	0.120				
	0.151				
	0.182				
	0.220				
	0.352				
	0.599				
	0.908				
	10.000				
	REFERENCE FILE				

BOOSTER ANGLE OF ATTACK, ALPHA DEGREES

PARAMETRIC VALUES			
BSTPOW	50.000	ORBPOW	100.000
DELTAZ	0.104	ALPHA1	0.000
MACH	5.010	ELVBST	0.000
ELVORB	0.000	BETA	0.000

REFERENCE INFORMATION		
REFS	23.6890	SQ IN
REFL	4.1930	IN
REFB	6.5000	IN
XMRP	4.9170	IN
YMRP	0.0000	IN
ZMRP	1.3900	IN
SCALE	0.0055	

# AEDC VA 1163 MDAC BOOSTER AND ORBITER TEST DATA AT MACH NUMBER 5

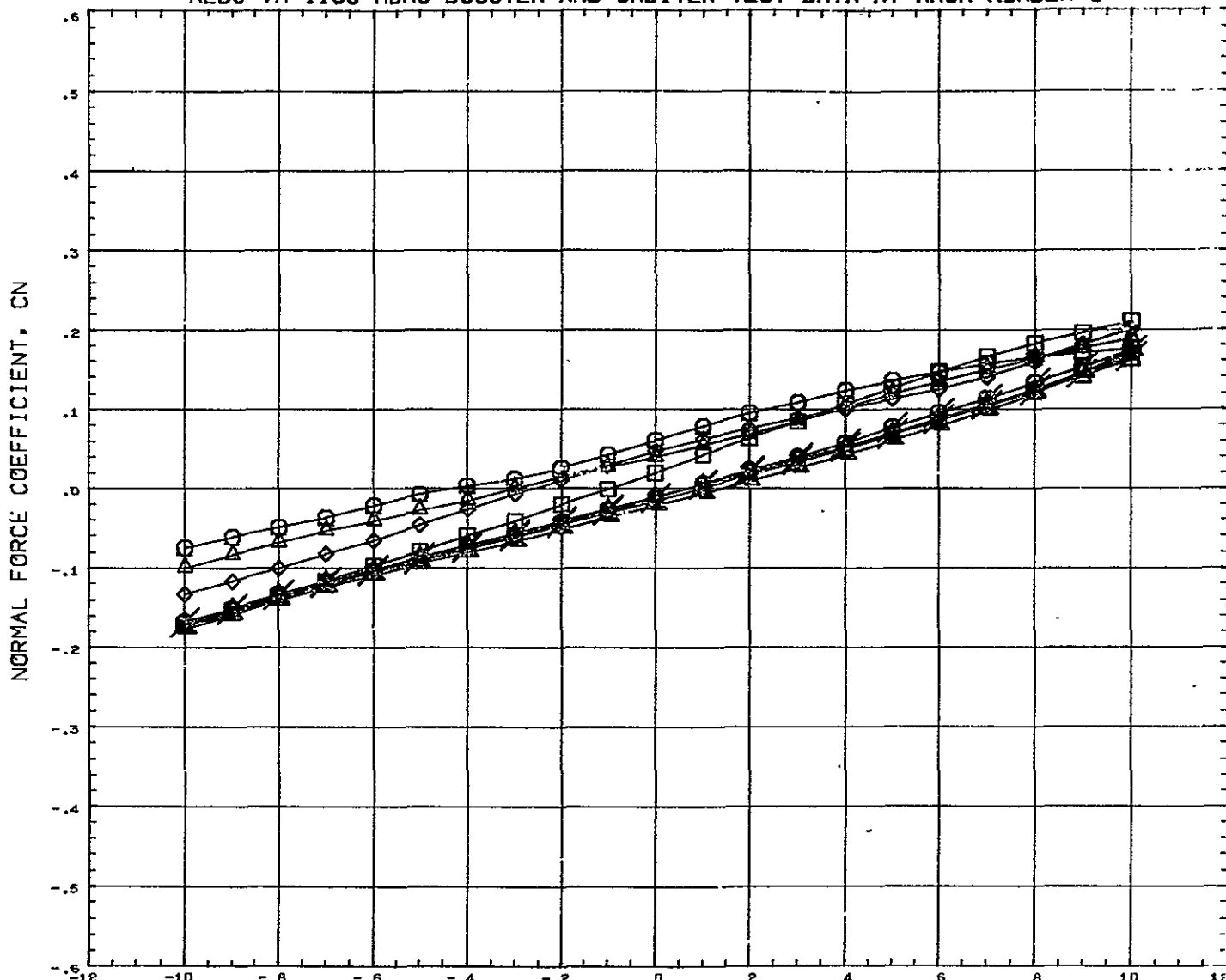

SYMBOL ○ ◇ □ △ * X 10.000	DELTAZ 0.120 0.151 0.182 0.228 0.352 0.599 0.908 10.000	PARAMETRIC VALUES BSTFOW 50.000 ORBPOW 100.000 DELTAX 0.104 ALPHA1 0.000 MACH 5.010 ELYBST 0.000 ELVORB 0.000 BETA 0.000 REFERENCE FILE	REFERENCE INFORMATION REFS 23.6890 SQ IN REFL 4.1930 IN REFB 6.5000 IN XMRP 4.9170 IN YMRP 0.0000 IN ZMRP 1.3900 IN SCALE 0.0055
--	---	--	---



# AEDC VA 1163 MDAC BOOSTER AND ORBITER TEST DATA AT MACH NUMBER 5

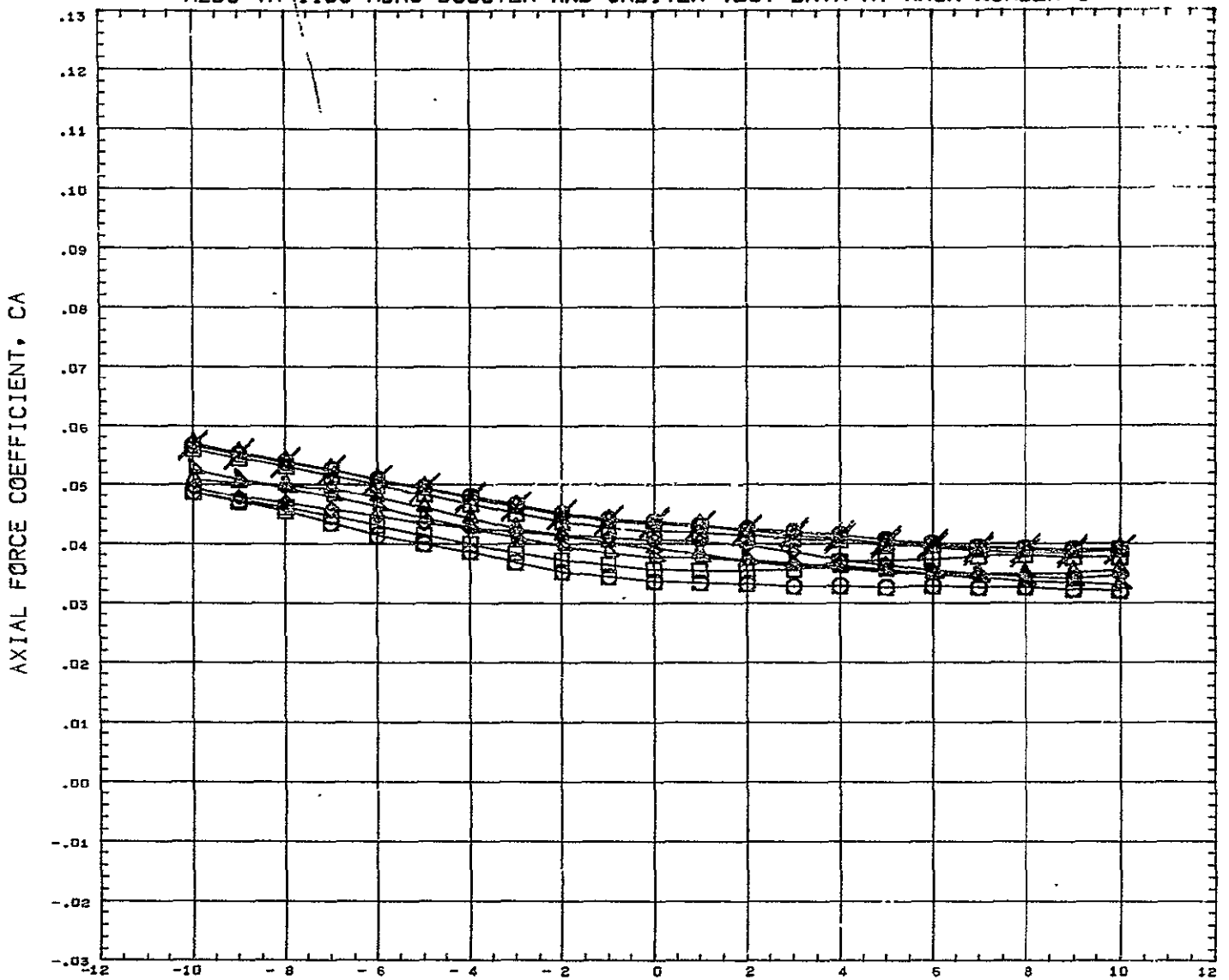

SYMBOL	DELTAZ	PARAMETRIC VALUES				REFERENCE INFORMATION		
0.120								
0.151								
0.182	BSTPOW	50.000	ORBPOW	100.000	REFS	23.6890	59 IN	
0.228	DELTAZ	0.104	ALPHA1	0.000	REFL	4.1930	IN	
0.352	MACH	5.010	ELVBST	0.000	REFB	6.5000	IN	
0.599	ELVORB	0.000	BETA	0.000	XMRP	4.9170	IN	
0.908					YMRP	0.0000	IN	
10.000	REFERENCE FILE				ZMRP	1.3900	IN	
					SCALE	0.0055		

# AEDC VA 1163 MDAC BOOSTER AND ORBITER TEST DATA AT MACH NUMBER 5

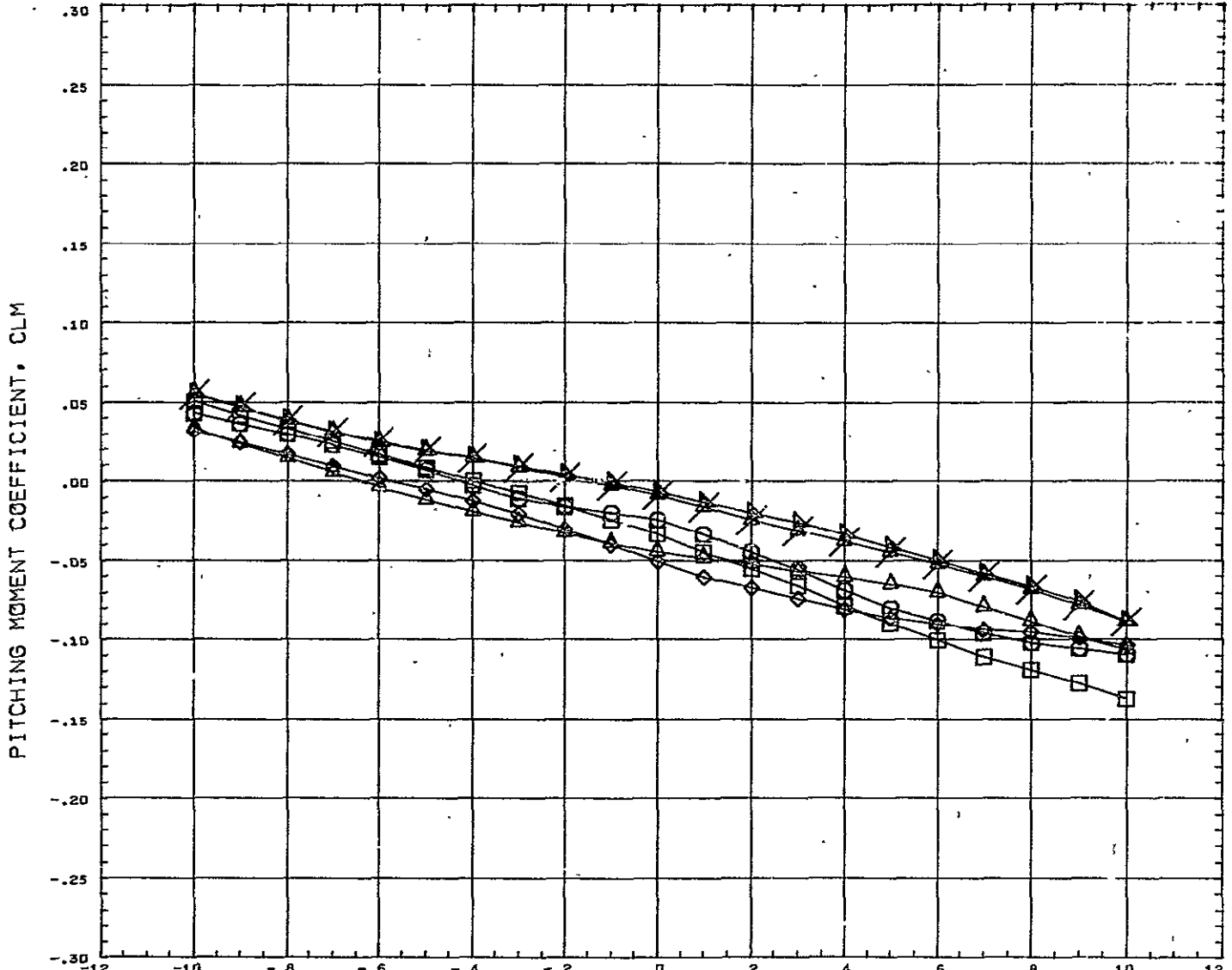

SYMBOL ○ ◇ □ △ ×	DELTAZ 0.120 0.151 0.182 0.228 0.352 10.000	<b>PARAMETRIC VALUES</b> BSTFOW 50.000 ORBPOW 100.000 DELTAX 0.166 ALPHAI 0.000 MACH 5.010 ELVBST 0.000 ELVORB 0.000 BETA 0.000	<b>REFERENCE INFORMATION</b> REFS 23.6890 SQ IN REFL 4.1930 IN REFB 6.5000 IN XMRP 4.9170 IN YMRP 0.0000 IN ZMRP 1.3900 IN SCALE 0.0055
---------------------------------	---	---	--

REFERENCE FILE

# AEDC VA 1163 MDAC BOOSTER AND ORBITER TEST DATA AT MACH NUMBER 5

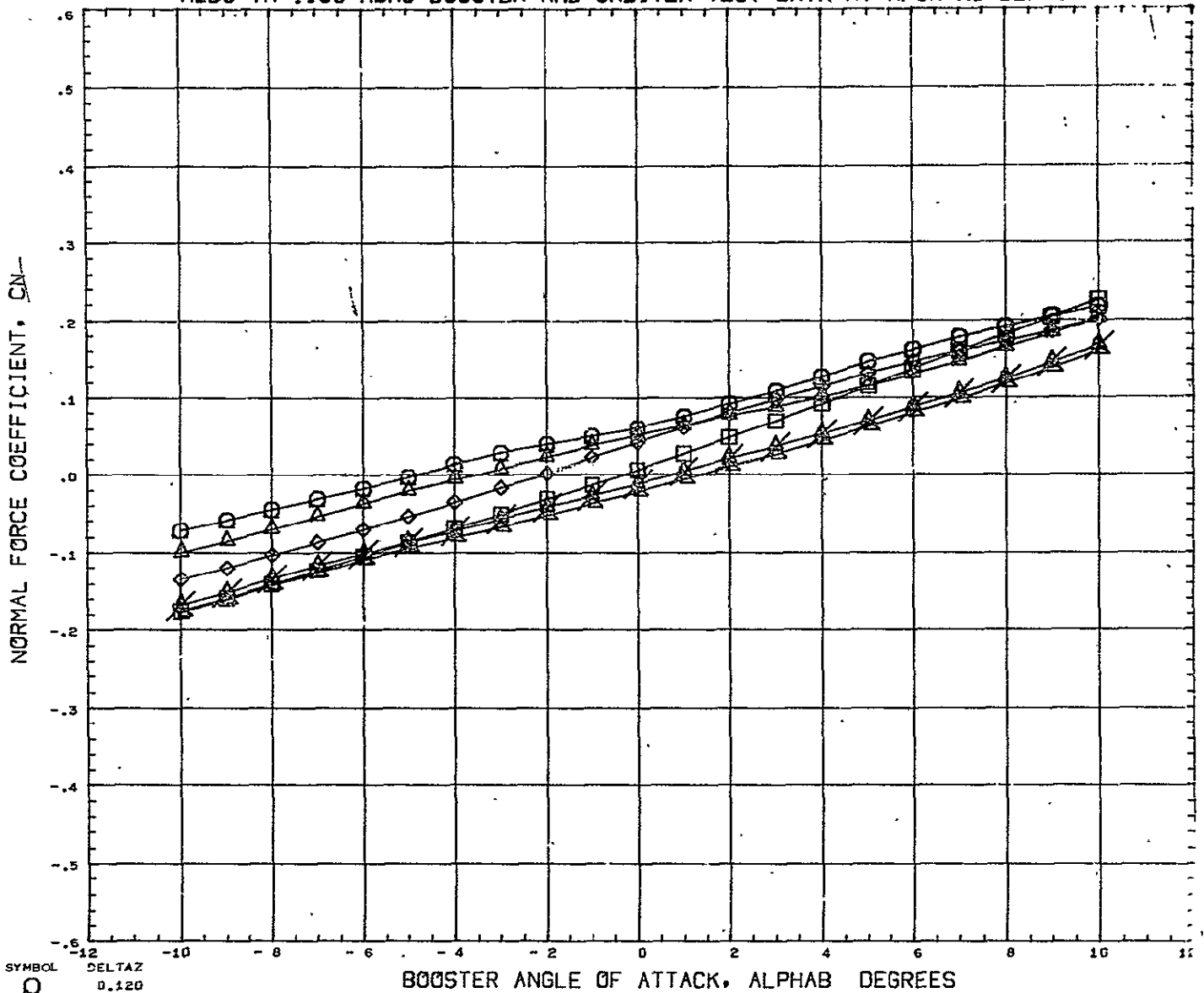

SYMBOL ○ ◇ □ △	DELTAX 0.120 0.151 0.162 0.228 0.352 10.000	<table border="0" style="width: 100%;"> <tr> <th colspan="4" style="text-align: center;">PARAMETRIC VALUES</th> </tr> <tr> <td>BSTPOW</td> <td>50.000</td> <td>ORBPOW</td> <td>100.000</td> </tr> <tr> <td>DELTAZ</td> <td>0.166</td> <td>ALPHA1</td> <td>0.000</td> </tr> <tr> <td>MACH</td> <td>5.010</td> <td>ELVBST</td> <td>0.000</td> </tr> <tr> <td>ELVORB</td> <td>0.000</td> <td>BETA</td> <td>0.000</td> </tr> </table>	PARAMETRIC VALUES				BSTPOW	50.000	ORBPOW	100.000	DELTAZ	0.166	ALPHA1	0.000	MACH	5.010	ELVBST	0.000	ELVORB	0.000	BETA	0.000	<table border="0" style="width: 100%;"> <tr> <th colspan="3" style="text-align: center;">REFERENCE INFORMATION</th> </tr> <tr> <td>REFS</td> <td>23.6890</td> <td>SQ IN</td> </tr> <tr> <td>REFL</td> <td>4.1930</td> <td>IN</td> </tr> <tr> <td>REFB</td> <td>6.5000</td> <td>IN</td> </tr> <tr> <td>XMRP</td> <td>4.9170</td> <td>IN</td> </tr> <tr> <td>YMRP</td> <td>0.0000</td> <td>IN</td> </tr> <tr> <td>ZMRP</td> <td>1.3900</td> <td>IN</td> </tr> <tr> <td>SCALE</td> <td>0.0055</td> <td></td> </tr> </table>	REFERENCE INFORMATION			REFS	23.6890	SQ IN	REFL	4.1930	IN	REFB	6.5000	IN	XMRP	4.9170	IN	YMRP	0.0000	IN	ZMRP	1.3900	IN	SCALE	0.0055	
PARAMETRIC VALUES																																															
BSTPOW	50.000	ORBPOW	100.000																																												
DELTAZ	0.166	ALPHA1	0.000																																												
MACH	5.010	ELVBST	0.000																																												
ELVORB	0.000	BETA	0.000																																												
REFERENCE INFORMATION																																															
REFS	23.6890	SQ IN																																													
REFL	4.1930	IN																																													
REFB	6.5000	IN																																													
XMRP	4.9170	IN																																													
YMRP	0.0000	IN																																													
ZMRP	1.3900	IN																																													
SCALE	0.0055																																														

REFERENCE FILE

# AEDC VA 1163 MDAC BOOSTER AND ORBITER TEST DATA AT MACH NUMBER 5

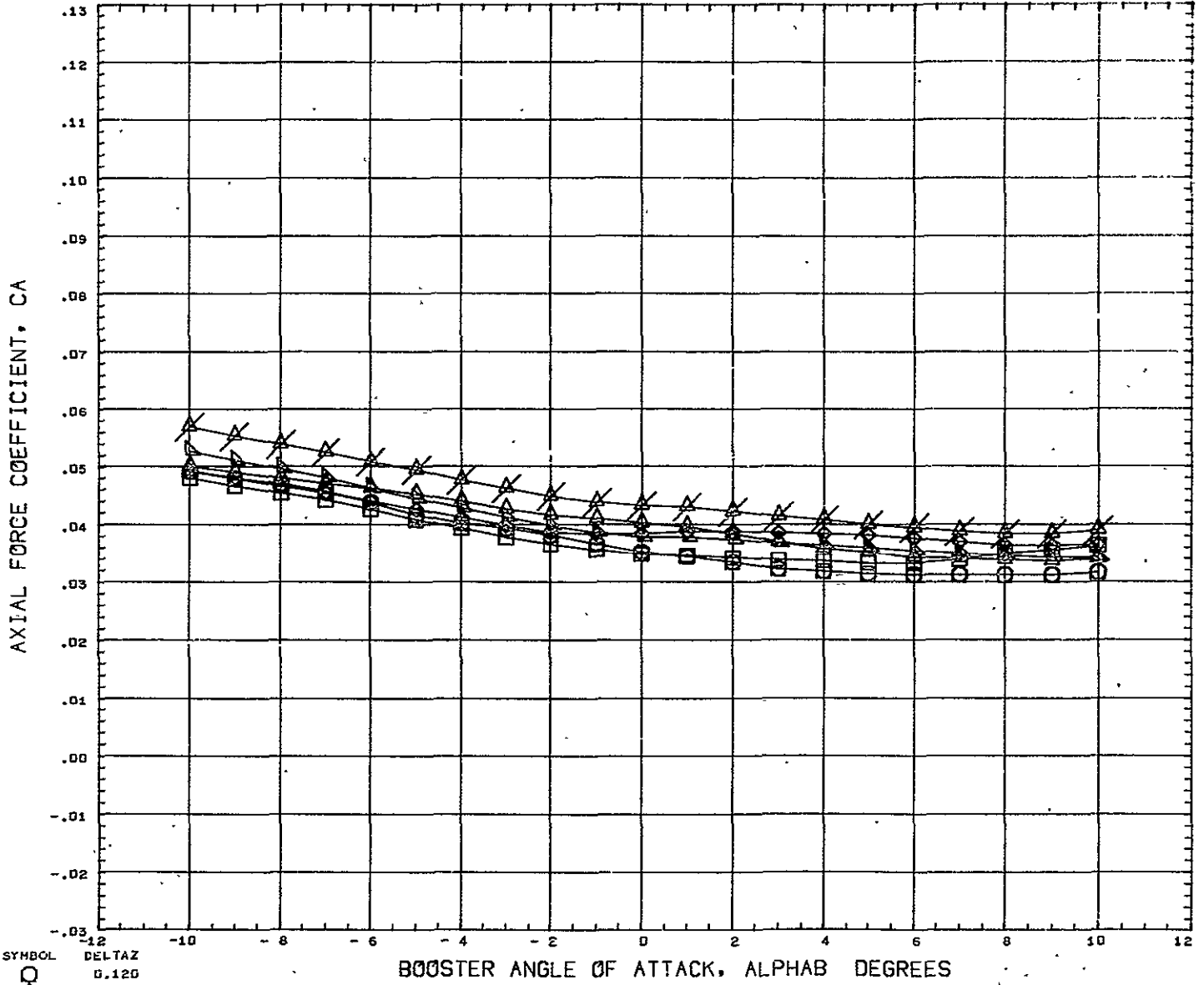

SYMBOL ○ □ ◇ △ △/	DELTAZ 0.120 0.151 0.182 0.228 0.352 10.000	<table border="0" style="width: 100%;"> <tr> <th colspan="4" style="text-align: left; border-bottom: 1px solid black;">PARAMETRIC VALUES</th> </tr> <tr> <td style="width: 25%;">BSTPOW</td> <td style="width: 25%;">50.000</td> <td style="width: 25%;">ORBPOW</td> <td style="width: 25%;">100.000</td> </tr> <tr> <td>DELTAZ</td> <td>0.166</td> <td>ALPHA1</td> <td>0.000</td> </tr> <tr> <td>MACH</td> <td>5.010</td> <td>ELVBST</td> <td>0.000</td> </tr> <tr> <td>ELVORB</td> <td>0.000</td> <td>BETA</td> <td>0.000</td> </tr> </table>	PARAMETRIC VALUES				BSTPOW	50.000	ORBPOW	100.000	DELTAZ	0.166	ALPHA1	0.000	MACH	5.010	ELVBST	0.000	ELVORB	0.000	BETA	0.000	<table border="0" style="width: 100%;"> <tr> <th colspan="3" style="text-align: left; border-bottom: 1px solid black;">REFERENCE INFORMATION</th> </tr> <tr> <td style="width: 33%;">REFS</td> <td style="width: 33%;">23.6990</td> <td style="width: 33%;">SQ IN</td> </tr> <tr> <td>REFL</td> <td>4.1930</td> <td>IN</td> </tr> <tr> <td>REFB</td> <td>6.5000</td> <td>IN</td> </tr> <tr> <td>XMRP</td> <td>4.9170</td> <td>IN</td> </tr> <tr> <td>YMRP</td> <td>0.0000</td> <td>IN</td> </tr> <tr> <td>ZMRP</td> <td>1.3900</td> <td>IN</td> </tr> <tr> <td>SCALE</td> <td>0.0055</td> <td></td> </tr> </table>	REFERENCE INFORMATION			REFS	23.6990	SQ IN	REFL	4.1930	IN	REFB	6.5000	IN	XMRP	4.9170	IN	YMRP	0.0000	IN	ZMRP	1.3900	IN	SCALE	0.0055	
PARAMETRIC VALUES																																															
BSTPOW	50.000	ORBPOW	100.000																																												
DELTAZ	0.166	ALPHA1	0.000																																												
MACH	5.010	ELVBST	0.000																																												
ELVORB	0.000	BETA	0.000																																												
REFERENCE INFORMATION																																															
REFS	23.6990	SQ IN																																													
REFL	4.1930	IN																																													
REFB	6.5000	IN																																													
XMRP	4.9170	IN																																													
YMRP	0.0000	IN																																													
ZMRP	1.3900	IN																																													
SCALE	0.0055																																														

REFERENCE FILE

# AEDC VA 1163 MDAC BOOSTER AND ORBITER TEST DATA AT MACH NUMBER 5

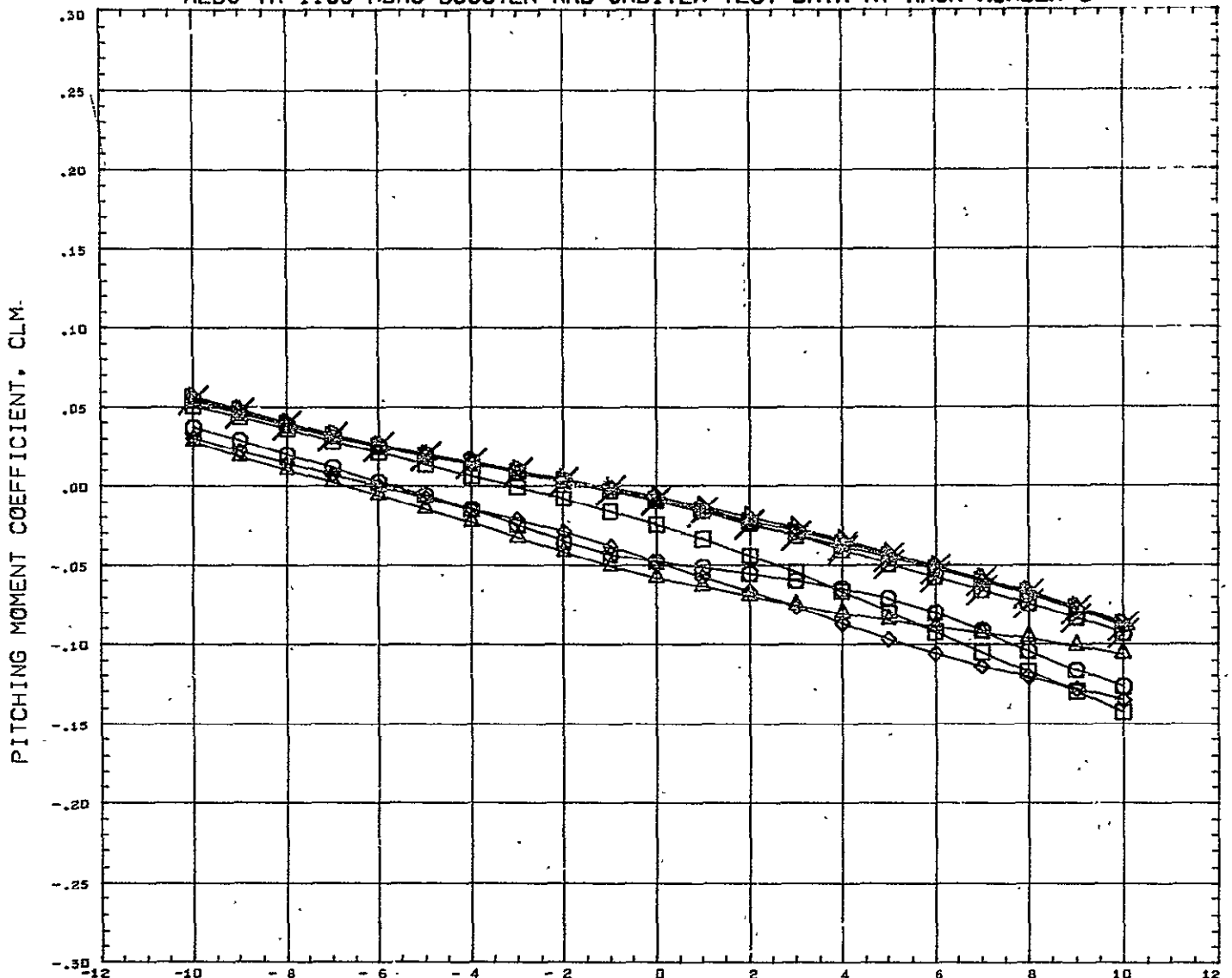

SYMBOL	DELTA Z	PARAMETRIC VALUES				REFERENCE INFORMATION	
○	0.120						
◇	0.151						
□	0.182	BSTPOW	50.000	ORBPOW	100.000	REFL	23.6890 SQ IN
△	0.228	DELTA X	0.228	ALPHA I	0.000	REFB	4.1930 IN
▽	0.352	MACH	5.010	ELVBST	0.000	XMRP	6.5000 IN
◇	0.599	ELVORB	0.000	BETA	0.000	YMRP	4.9170 IN
○	0.908					ZMRP	0.0000 IN
◇	10.000	REFERENCE FILE				SCALE	1.3900 IN
							0.0055

# AEDC VA 1163 MDAC BOOSTER AND ORBITER TEST DATA AT MACH NUMBER 5

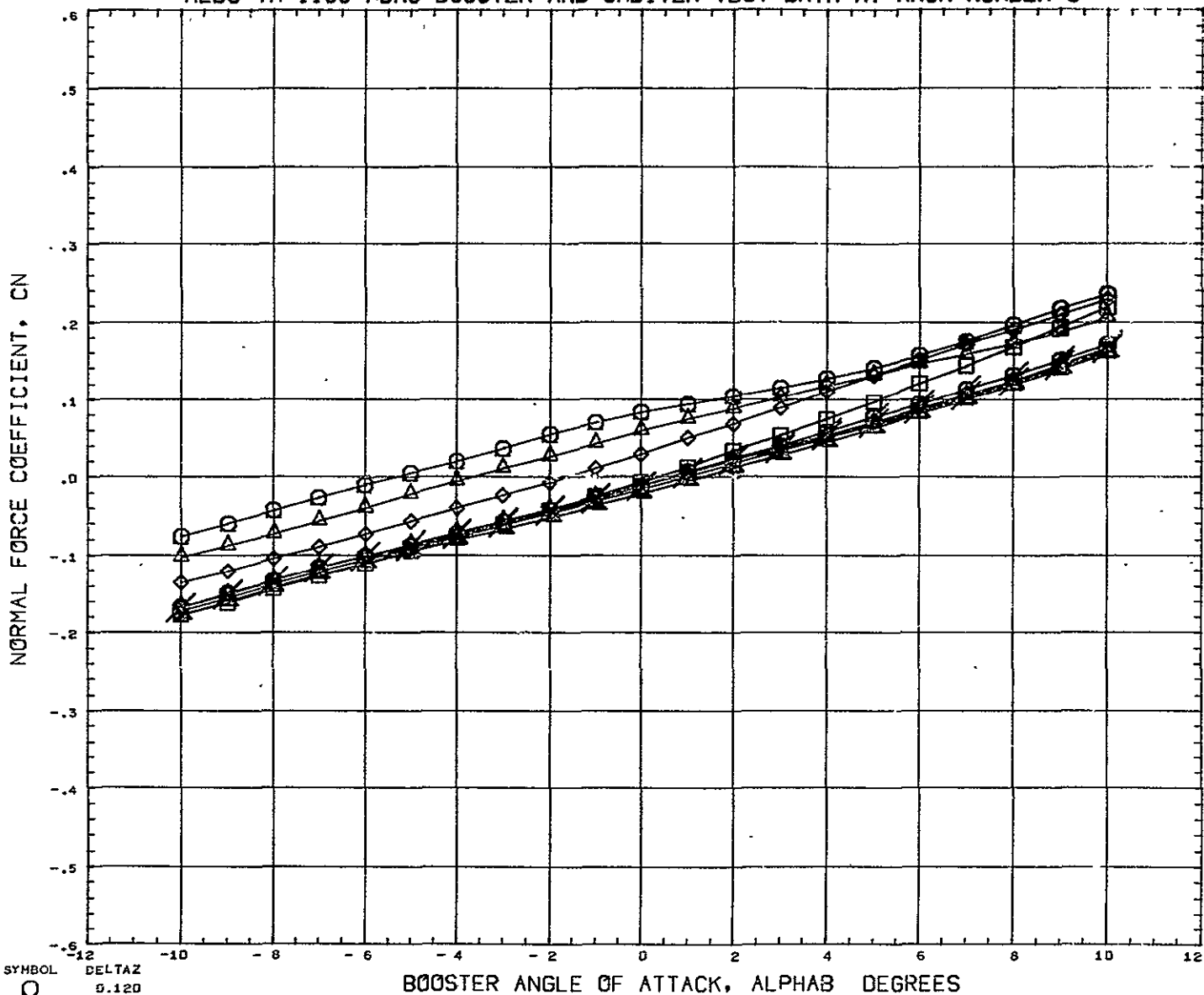

SYMBOL ○ △ ◇ □ ▽ ⊠ ⊞ ⊚ ⊛ ⊜ ⊝ ⊞ ⊚ ⊛ ⊜ ⊝	DELTAX 0.120 0.151 0.182 0.228 0.352 0.599 0.908 10.000	PARAMETRIC VALUES BSTFOW 50.000 ORBFOW 100.000 DELTAX 0.228 ALPHAI 0.000 MACH 5.010 ELVBST 0.000 ELVORB 0.000 BETA 0.000	REFERENCE INFORMATION REFS 23.6890 SQ IN REFL 4.1330 IN REFB 6.5000 IN XMRP 4.9170 IN YMRP 0.0000 IN ZMRP 1.3900 IN SCALE 0.0055
BOOSTER ANGLE OF ATTACK, ALPHAB DEGREES			

# AEDC VA 1163 MDAC BOOSTER AND ORBITER TEST DATA AT MACH NUMBER 5

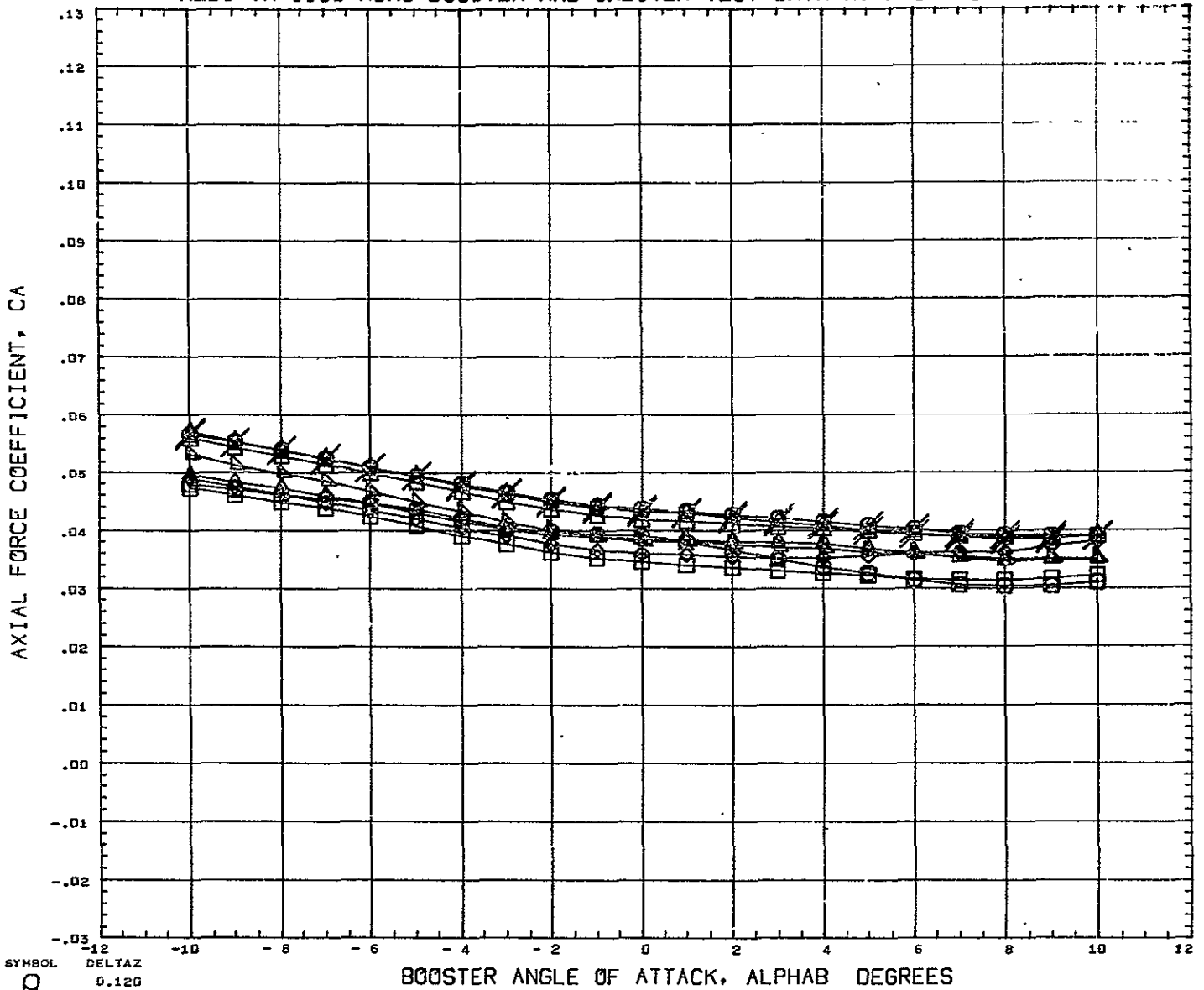

SYMBOL	DELTAZ	PARAMETRIC VALUES				REFERENCE INFORMATION		
○	0.120							
○	0.151							
○	0.182	BSTPOW	50.000	ORBPOW	100.000	REFS	23.6890	50 IN
○	0.228	DELTAZ	0.228	ALPHA1	0.000	REFL	4.1930	IN
○	0.352	MACH	5.010	ELVBST	0.000	REFB	6.5000	IN
○	0.599	ELVORB	0.000	BETA	0.000	XMRP	4.9170	IN
○	0.908					YMRP	0.0000	IN
○	10.000	REFERENCE FILE				ZMRP	1.3900	IN
						SCALE	0.0055	

# AEDC VA 1163 MDAC BOOSTER AND ORBITER TEST DATA AT MACH NUMBER 5

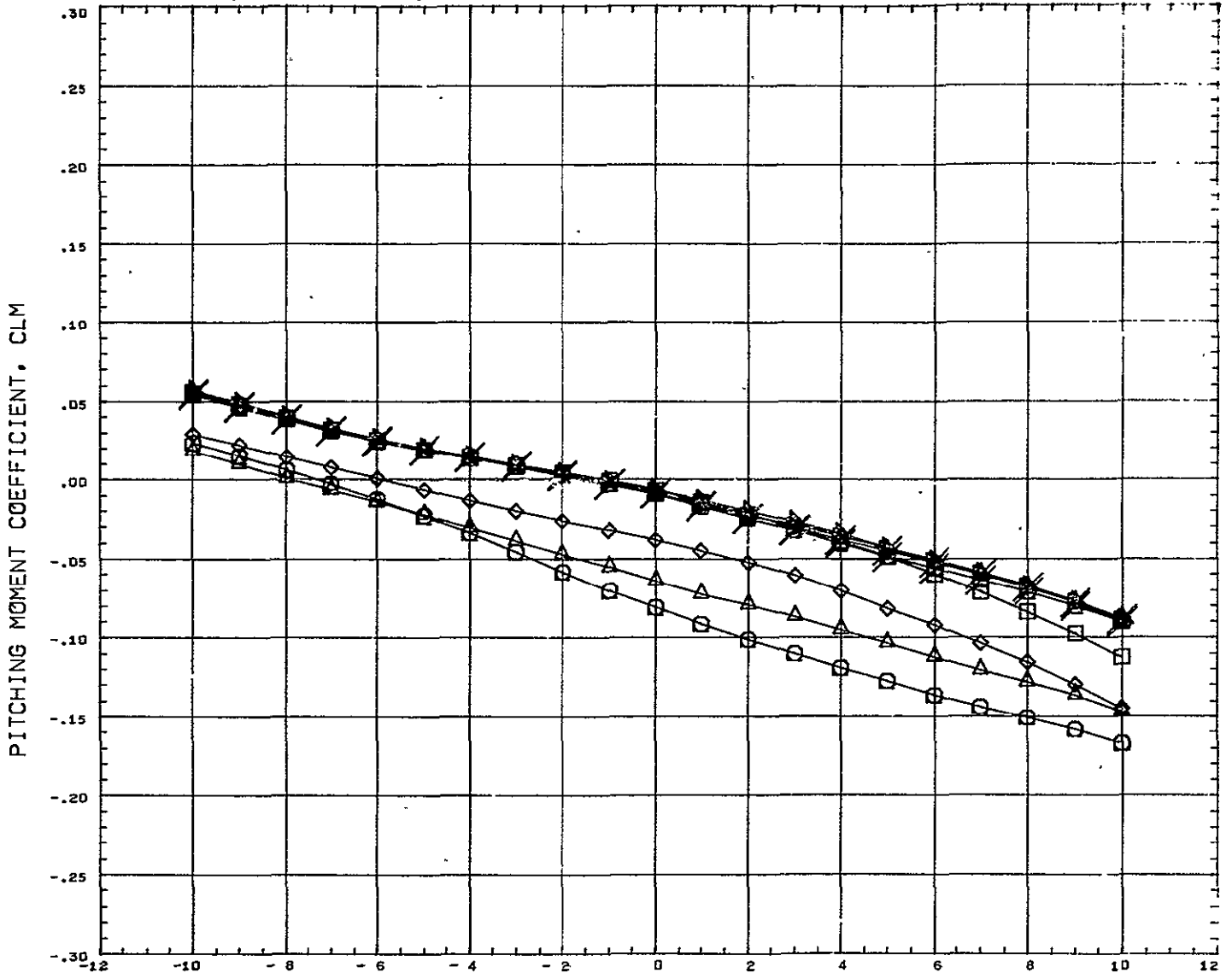

SYMBOL	DELTA Z	PARAMETRIC VALUES				REFERENCE INFORMATION		
○	0.120							
□	0.151							
◇	0.182	BSTFOW	50.000	ORBFOW	100.000	REFS	23.6890	SG IN
△	0.228	DELTA X	0.351	ALPHA I	0.000	REFL	4.1930	IN
×	0.352	MACH	5.010	ELVBST	0.000	REFB	6.5000	IN
○	0.599	ELVORB	0.000	BETA	0.000	XMRP	4.9170	IN
○	0.908					YMRP	0.0060	IN
○	10.000	REFERENCE FILE				ZMRP	1.3900	IN
						SCALE	0.0055	



# AEDC VA 1163 MDAC BOOSTER AND ORBITER TEST DATA AT MACH NUMBER 5

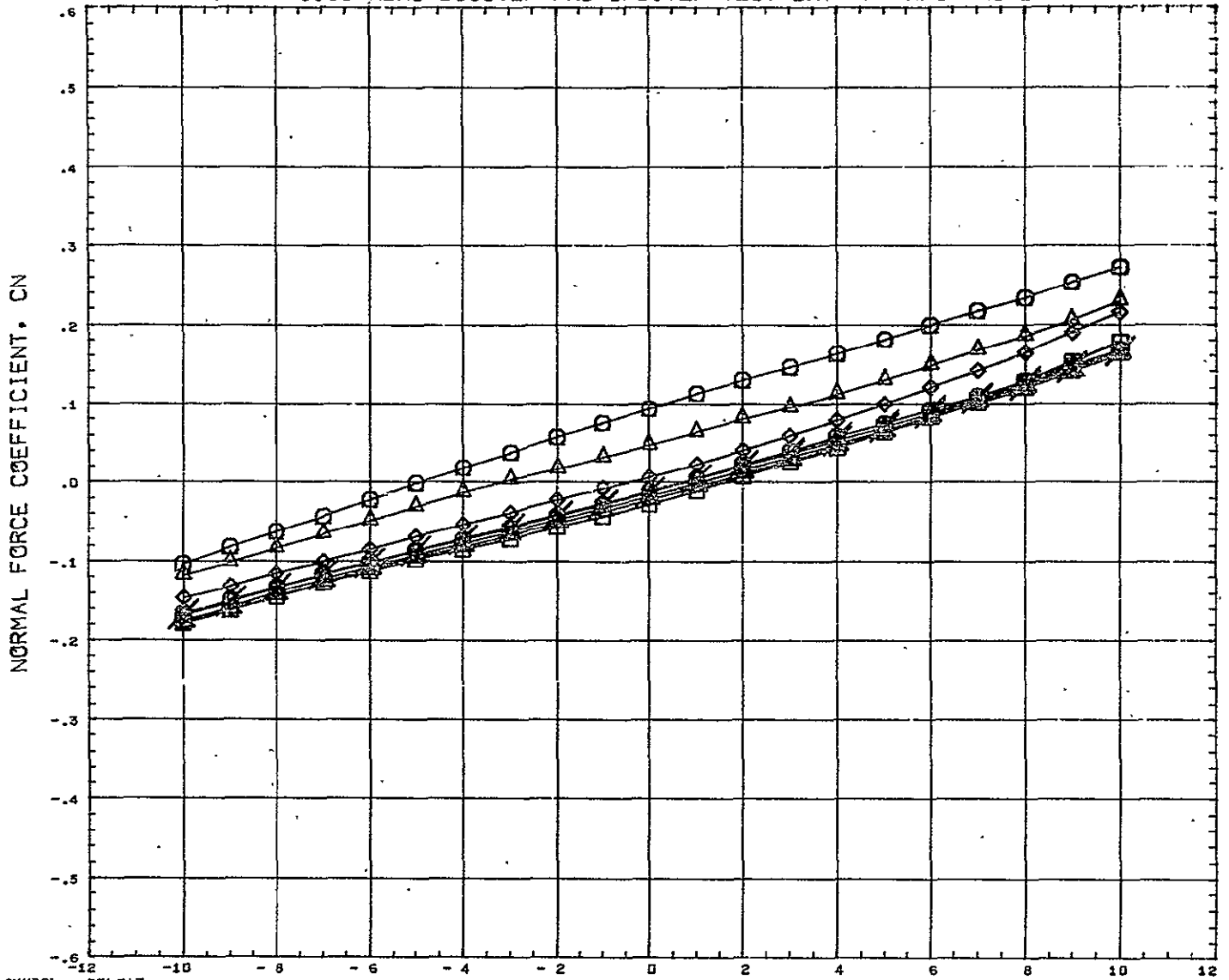

SYMBOL $\square$ $\diamond$ $\triangle$ $\circ$ $\square$ $\diamond$ $\triangle$ $\circ$ $\square$ $\diamond$ $\triangle$ $\circ$	DELTAZ 0.120 0.151 0.182 0.228 0.352 0.599 0.998 10.000	<b>PARAMETRIC VALUES</b> BSTPOW 50.000 ORBPOW 100.000 DELTAX 0.351 ALPHAI 0.000 MACH 5.010 ELVBST 0.000 ELVORB 0.000 BETA 0.000	<b>REFERENCE INFORMATION</b> REFS 23.6890 SQ IN REFL 4.1930 IN REFB 6.5000 IN XMRP 4.9170 IN YMRP 0.0000 IN ZMRP 1.3900 IN SCALE 0.0055
REFERENCE FILE			

# AEDC VA 1163 MDAC BOOSTER AND ORBITER TEST DATA AT MACH NUMBER 5

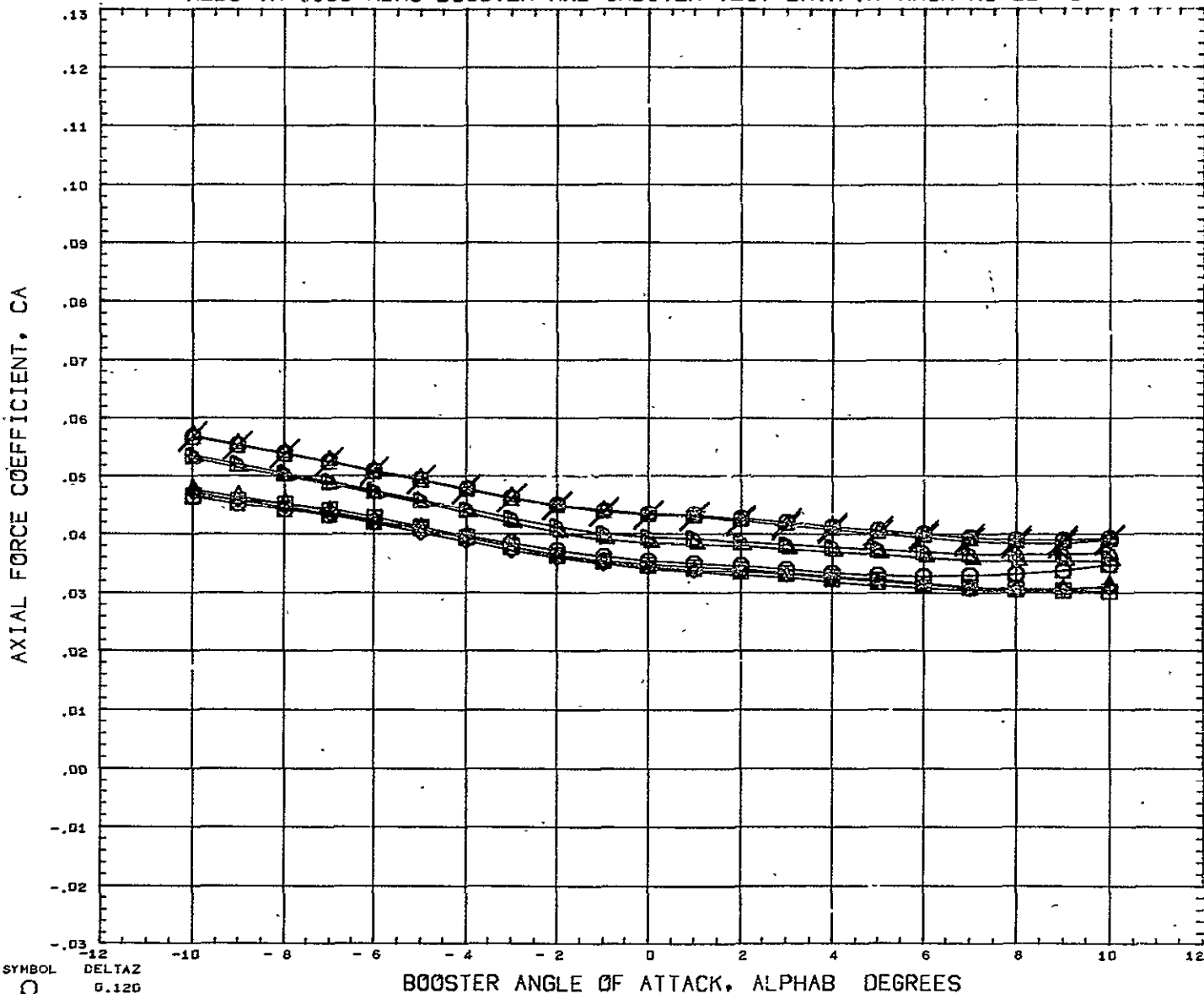

SYMBOL ○ ◇ □ △ × ○	DELTAZ 0.120 0.151 0.182 0.228 0.352 0.599 0.998 10.000	PARAMETRIC VALUES BSTPOW 50,000 ORBPOW 100,000 DELTAX 0.351 ALPHAI 0.000 MACH 5.010 ELVBST 0.000 ELVORB 0.000 BETA 0.000	REFERENCE INFORMATION REFS 23.6890 SQ IN REFL 4.1930 IN REFB 6.5000 IN XMRF 4.9170 IN YMRF 0.0000 IN ZMRF 1.3900 IN SCALE 0.0055
	BOOSTER ANGLE OF ATTACK, ALPHAB DEGREES		

# AEDC VA 1163 MDAC BOOSTER AND ORBITER TEST DATA AT MACH NUMBER 5

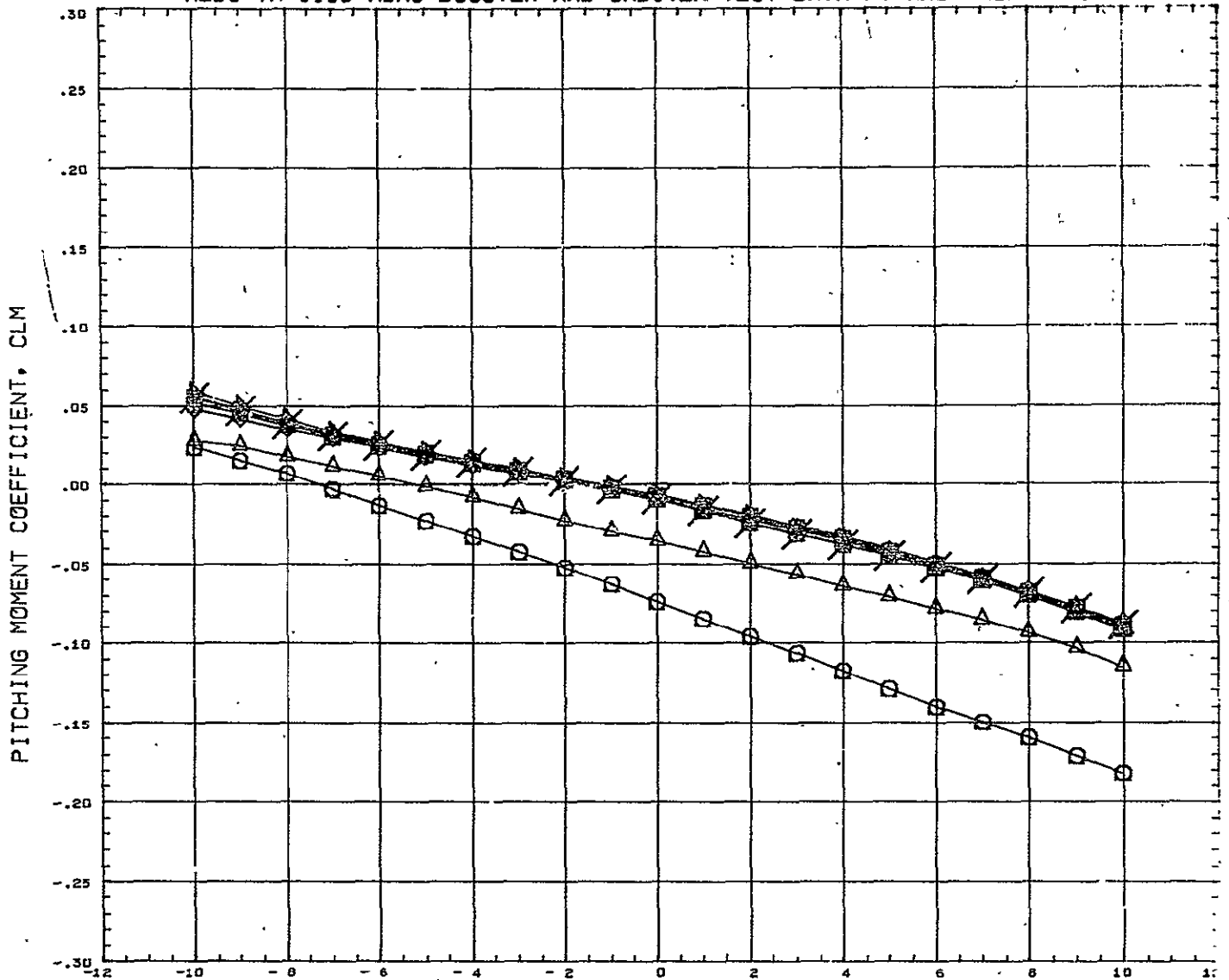

SYMBOL ○ □ △ ☆ ◇	DELTAZ 0.120 0.151 0.182 0.228 0.352 0.599 0.908 10.000	<b>BOOSTER ANGLE OF ATTACK, ALPHAB DEGREES</b>  PARAMETRIC VALUES BSTFOW 50.000 ORBPOW 100.000 DELTAX 0.522 ALPHAI 0.000 MACH 5.010 ELVBST 0.000 ELVORB 0.000 BETA 0.000	REFERENCE INFORMATION REFS 23.6890 SQ IN REFL 4.1930 IN REFB 6.5000 IN XMRP 4.9170 IN YMRP 0.6880 IN ZMRP 1.3900 IN SCALE 0.0055
	REFERENCE FILE		

# AEDC VA 1163 MDAC BOOSTER AND ORBITER TEST DATA AT MACH NUMBER 5

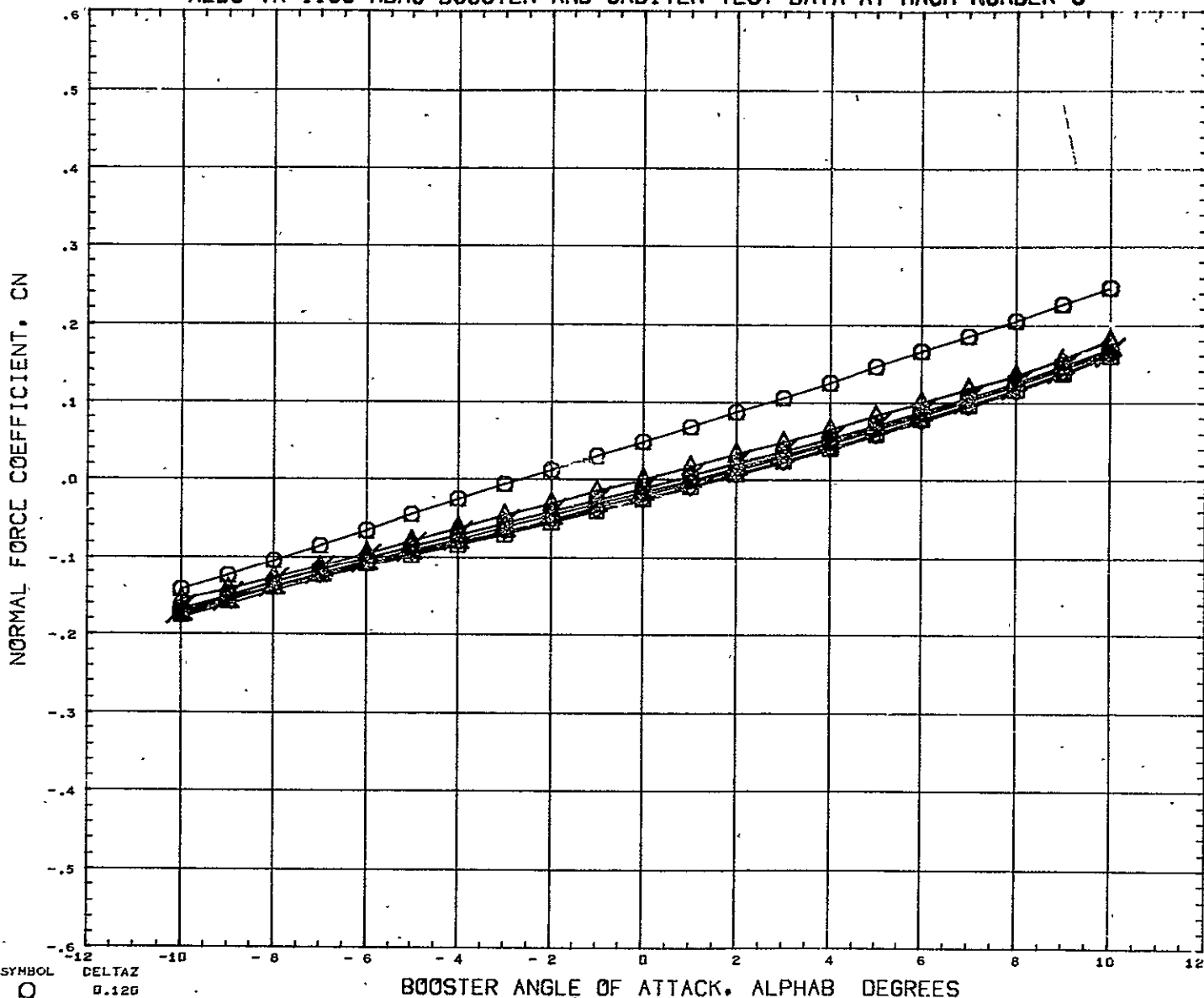

SYMBOL ○ □ △ ◇ ×	DELTAX 0.120 0.151 0.182 0.228 0.352 0.599 0.908 10.000	PARAMETRIC VALUES BSTFOW 50.000 ORBFW 100.000 DELTAX 0.522 ALPHA1 0.000 MACH 5.010 ELVBST 0.000 ELVORB 0.000 BETA 0.000	REFERENCE INFORMATION REFS 23.6890 SQ IN REFL 4.1935 IN REFB 6.5000 IN XMRP 4.9170 IN YMRP 0.0000 IN ZMRP 1.3900 IN SCALE 0.0055
	BOOSTER ANGLE OF ATTACK, ALPHA B DEGREES		

# AEDC VA 1163 MDAC BOOSTER AND ORBITER TEST DATA AT MACH NUMBER 5

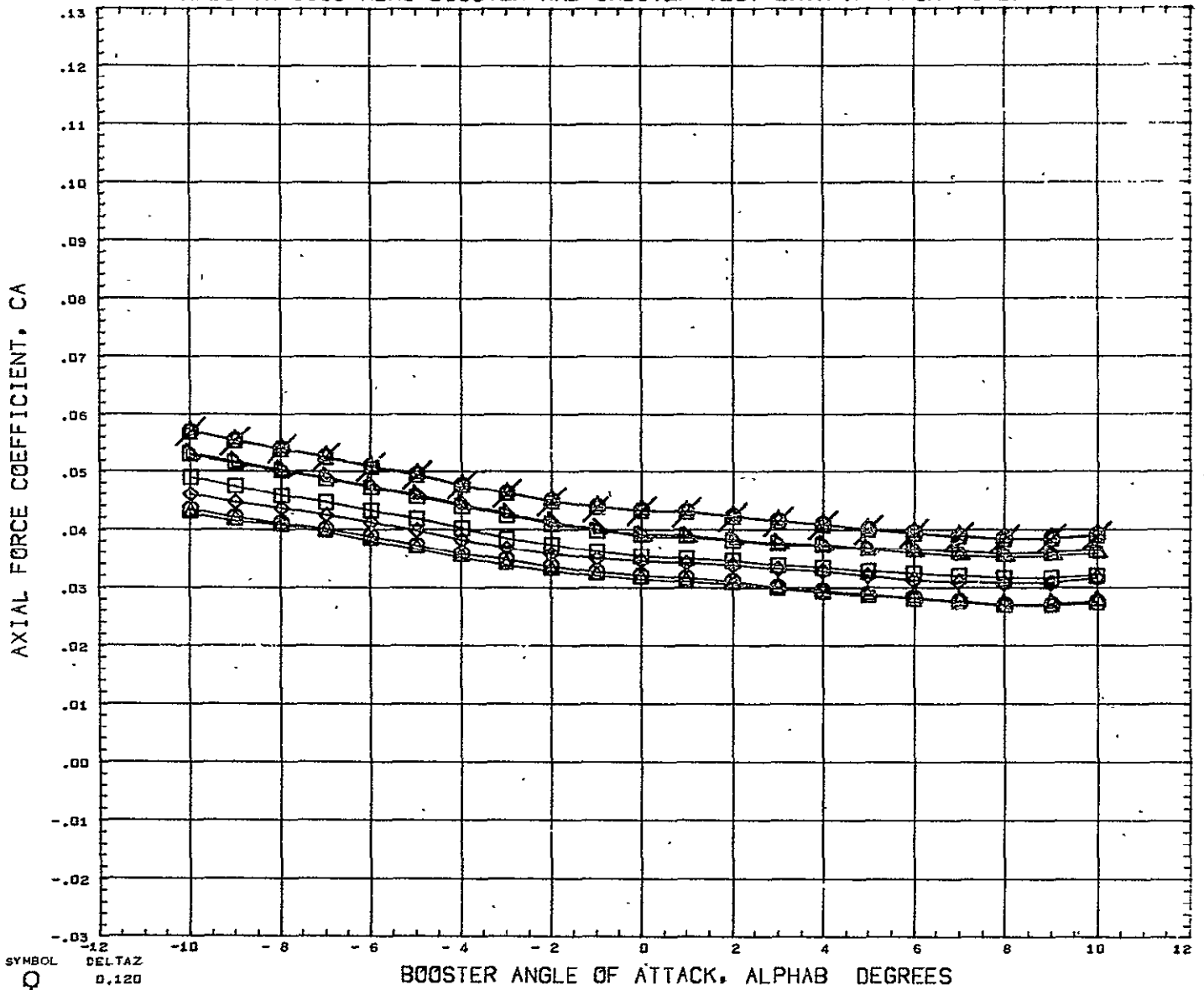

SYMBOL <del>0.120</del> <del>0.151</del> <del>0.182</del> <del>0.228</del> <del>0.352</del> <del>0.599</del> <del>0.908</del> <del>10.000</del>	DELTA Z 0.120 0.151 0.182 0.228 0.352 0.599 0.908 10.000	PARAMETRIC VALUES BSTPOW 50.000 ORBPOW 100.000 DELTAX 0.522 ALPHAI 0.000 MACH 5.010 ELVBST 0.000 ELVORB 0.000 BETA 0.000	REFERENCE INFORMATION REFS 23.6890 sq IN REFL 4.1930 IN REFB 6.5000 IN XMRP 4.9170 IN YMRP 0.0000 IN ZMRP 1.3900 IN SCALE 0.0055
---	--	--	---

# AEDC VA 1163 MDAC BOOSTER AND ORBITER TEST DATA AT MACH NUMBER 5

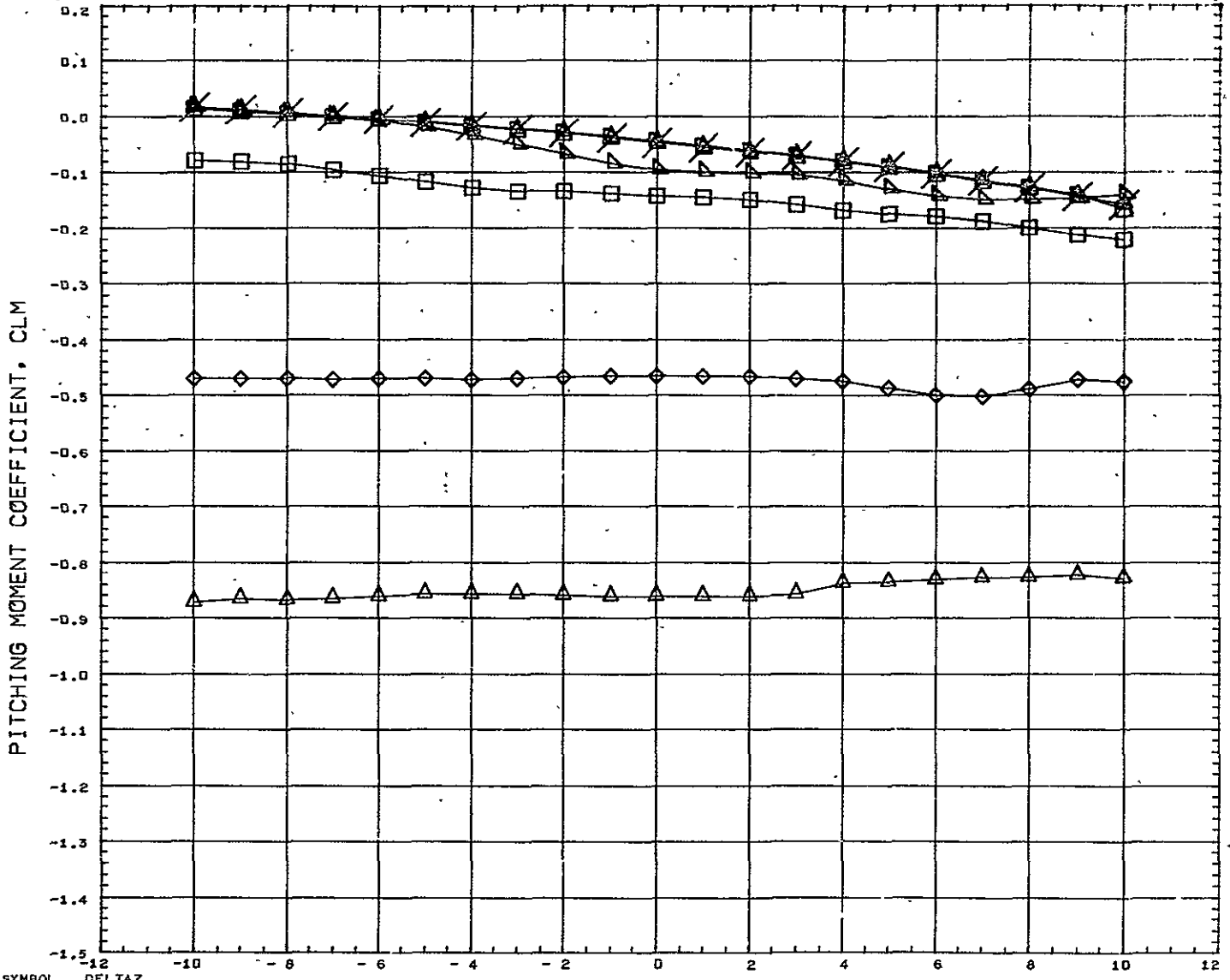

SYMBOL △ ◇ □ ▽ ▲	DELTAZ 0.151 0.182 0.228 0.352 0.599 10.000	PARAMETRIC VALUES BSTPOW 50.000 ORBPOW 100.000 DELTAX - 0.390 ALPHAI 5.100 MACH 5.010 ELVBST 0.000 ELVORB 0.000 BETA 0.000	REFERENCE INFORMATION REFS 23.6890 SQ IN REFL 4.1930 IN REFB 6.5000 IN XMRP 4.9170 IN YMRP 0.0000 IN ZMRP 1.3900 IN SCALE 0.0055
---------------------------------	---	--	---

REFERENCE FILE

# AEDC VA 1163 MDAC BOOSTER AND ORBITER TEST DATA AT MACH NUMBER 5

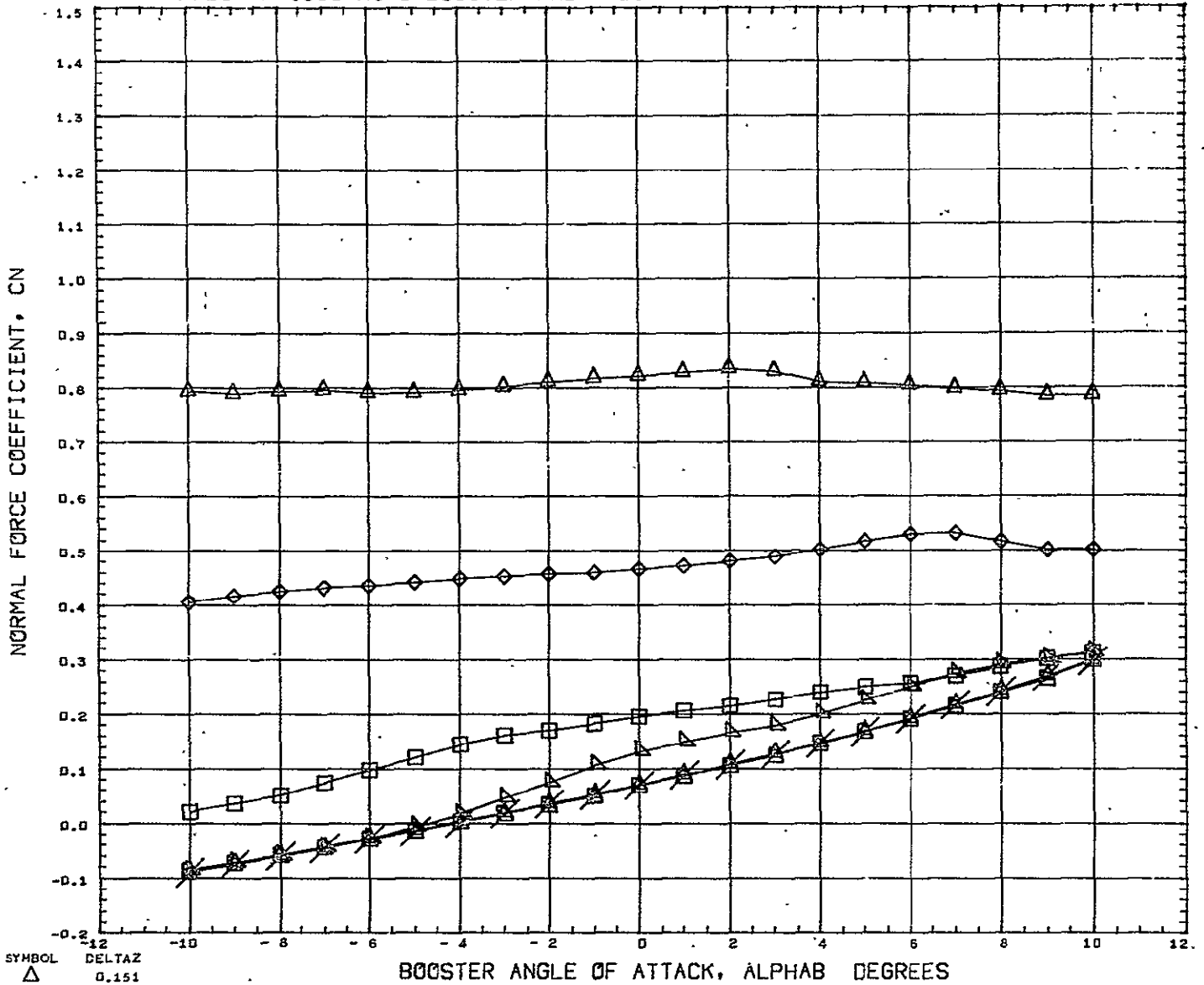

SYMBOL ◻ ◊ △ ×	DELTAZ 0.151 0.182 0.228 0.352 0.599 10.000	PARAMETRIC VALUES BSTPOW 50.000 ORBPOW 100.000 DELTAX - 0.390 ALPHAI 5.100 MACH 5.010 ELVBST 0.000 ELVORB 0.000 BETA 0.000	REFERENCE INFORMATION REFS 23.6890 S3 IN REFL 4.1930 IN REFB 6.5000 IN XMRP 4.9170 IN YMRP 0.0000 IN ZMRP 1.3900 IN SCALE 0.0055
----------------------------	---	--	---

REFERENCE FILE

# AEDC VA 1163 MDAC BOOSTER AND ORBITER TEST DATA AT MACH NUMBER 5

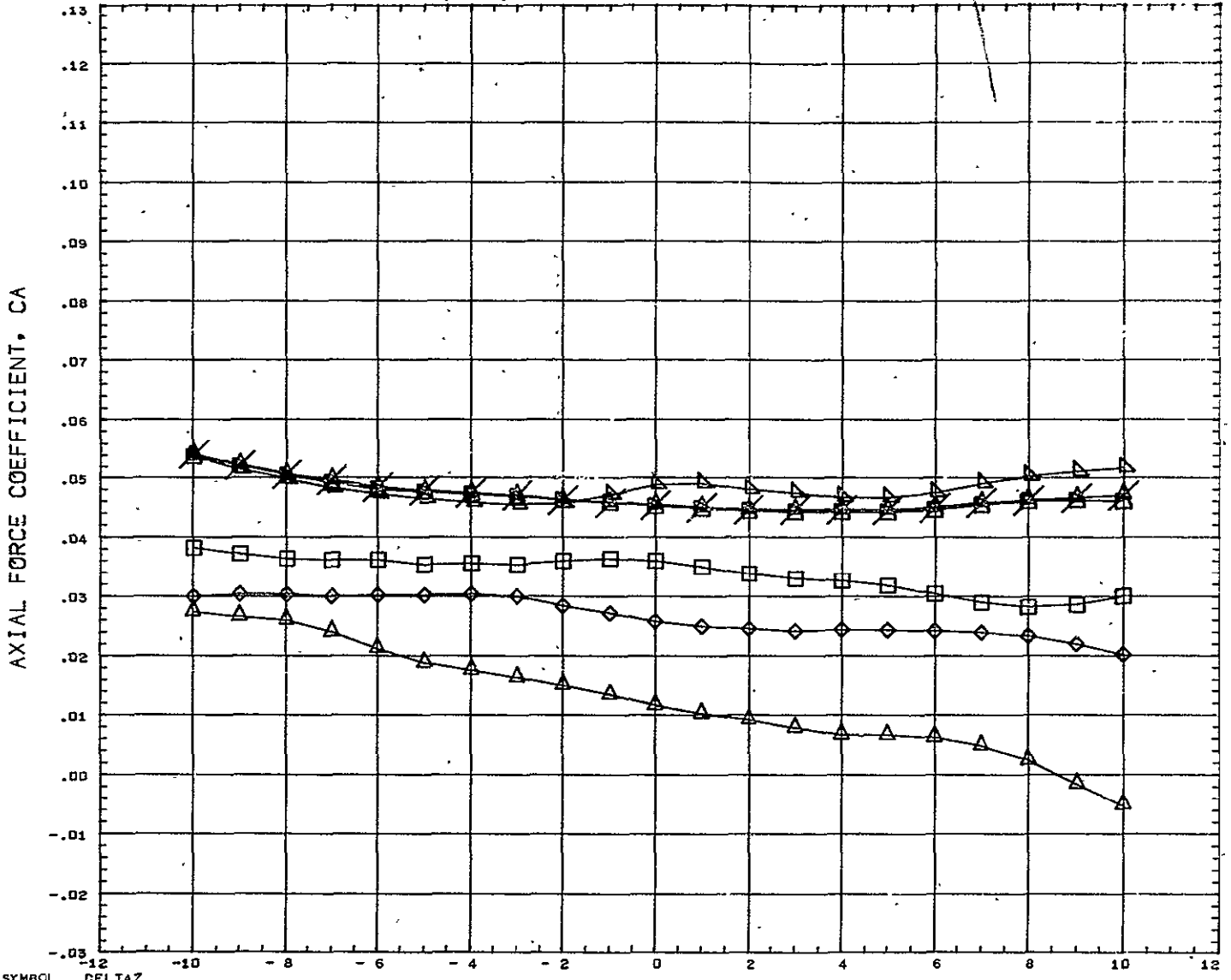

SYMBOL △ ◊ □ ▽ ×	DELTAZ 0.151 0.182 0.220 0.352 0.599 10.000	PARAMETRIC VALUES BSTPOW 50.000 ORBPOW 100.000 DELTAX - 0.390 ALPHAI 5.100 MACH 5.010 ELVBST .0.000 ELVORB 0.000 BETA 0.000	REFERENCE INFORMATION REFS 23.6890 SQ IN REFL 4.1930 IN REFB 6.5000 IN XMRP 4.9170 IN YMRP 0.0000 IN ZMRP 1.3900 IN SCALE 0.0055
---------------------------------	---	---	---

REFERENCE FILE



# AEDC VA 1163 MDAC BOOSTER AND ORBITER TEST DATA AT MACH NUMBER 5

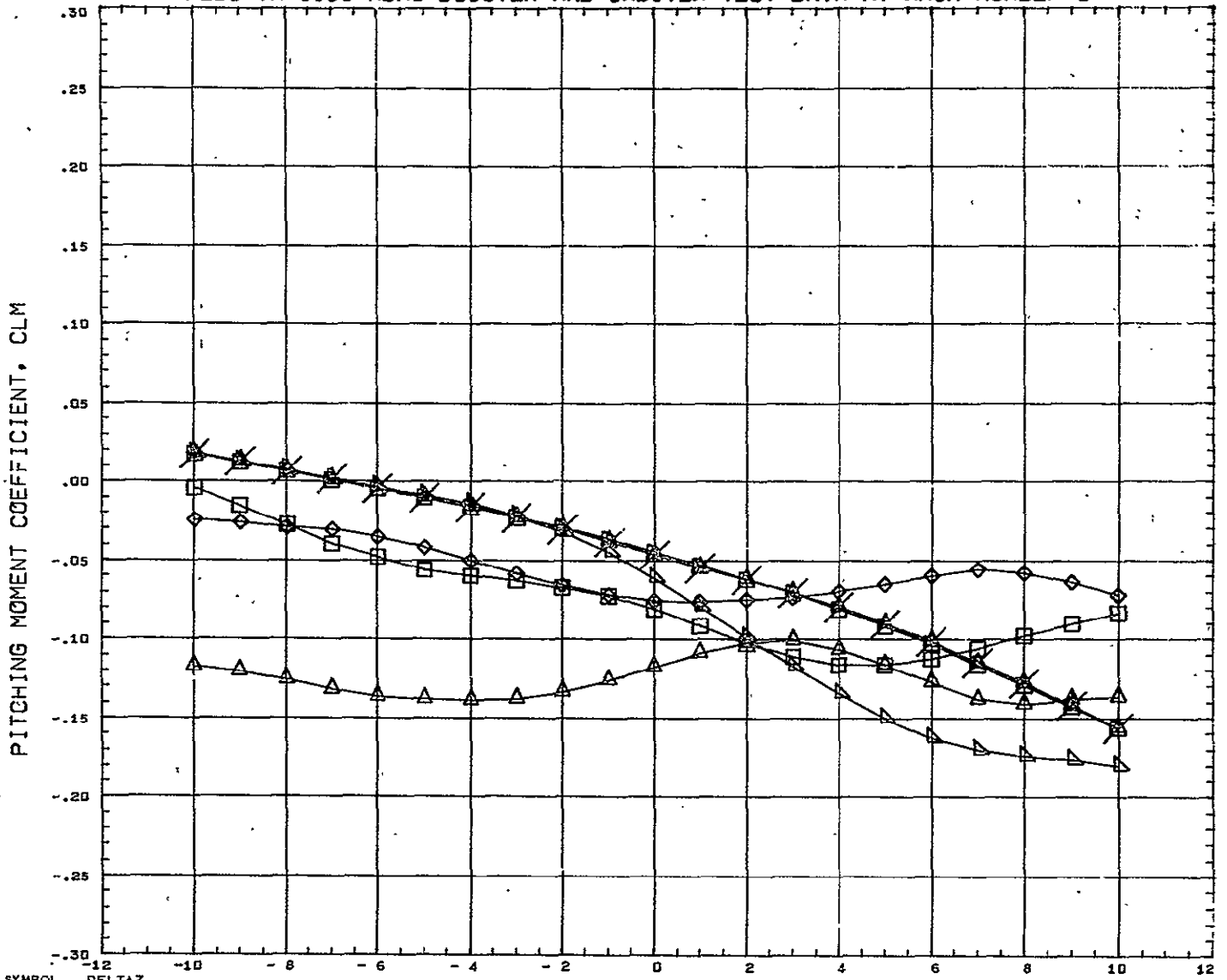

SYMBOL ◇ ◻ △ × ▽	DELTAX 0.151 0.182 0.228 0.352 0.599 10.000	PARAMETRIC VALUES BSTFOW 50.000 ORBFOV 100.000 DELTAX - 0.143 ALPHAI 5.100 MACH 5.010 ELVBST 0.000 ELVORB 0.000 BETA 0.000	REFERENCE INFORMATION REFS 23.6690 SQ IN REFL 4.1930 IN REFB 6.5000 IN XMRP 4.9170 IN YMRP 0.0000 IN ZMRP 1.3900 IN SCALE 0.0055
REFERENCE FILE			

# AEDC VA 1163 MDAC BOOSTER AND ORBITER TEST DATA AT MACH NUMBER 5

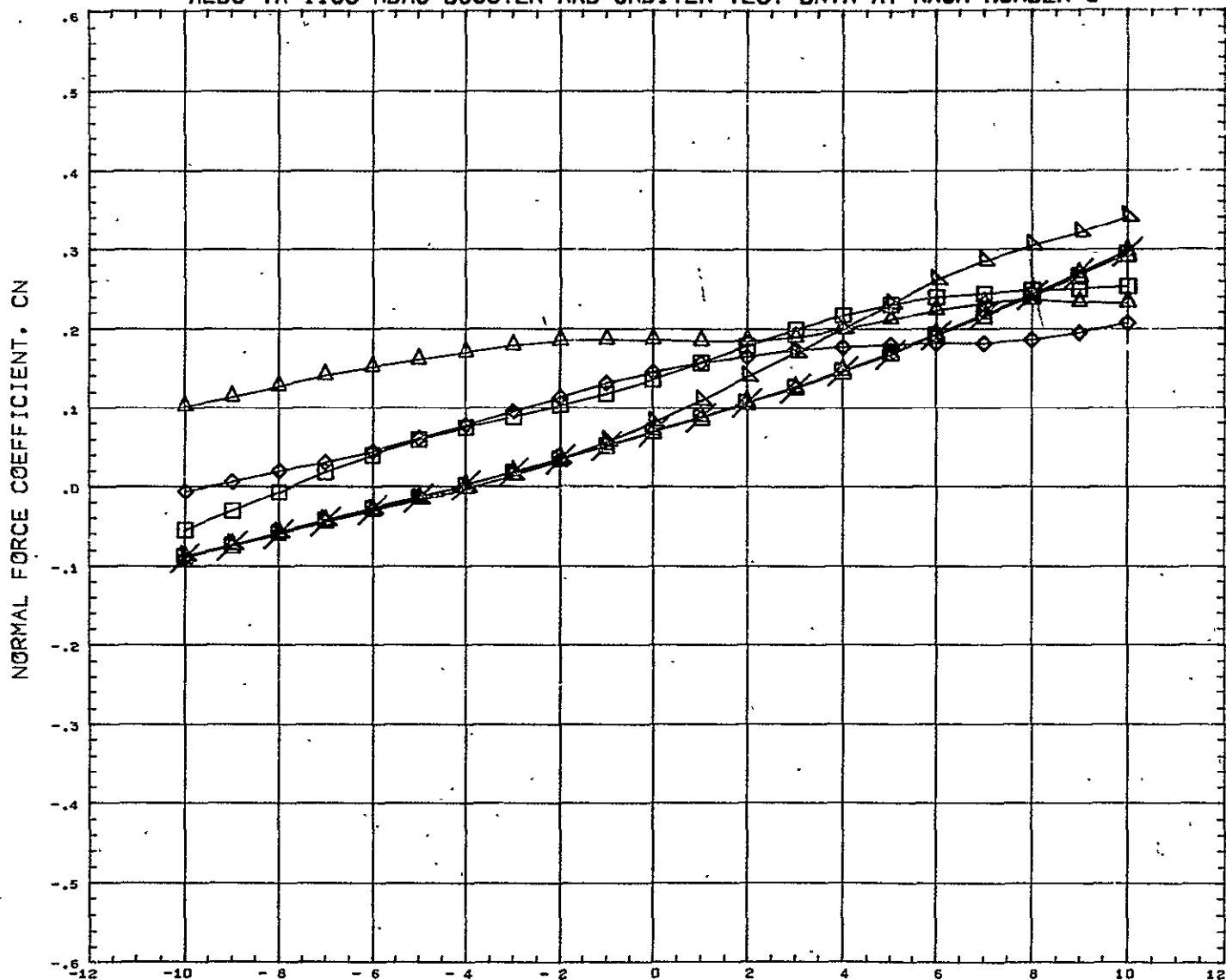

SYMBOL	DELTA Z	PARAMETRIC VALUES				REFERENCE INFORMATION		
△	0.151	BSTPOW	50.000	ORBPOW	100.000	REFS	23.6890	SQ IN
◇	0.182	DELTA X	0.143	ALPHA I	5.100	REFL	4.1930	IN
□	0.228	MACH	5.010	ELVBST	0.000	REFB	6.5000	IN
○	0.352	ELVORB	0.000	BETA	0.000	XMRF	4.9170	IN
×	0.599					YMRP	0.0000	IN
◇	10.000					ZMRP	1.3900	IN
						SCALE	0.0055	

REFERENCE FILE

# AEDC VA 1163 MDAC BOOSTER AND ORBITER TEST DATA AT MACH NUMBER 5

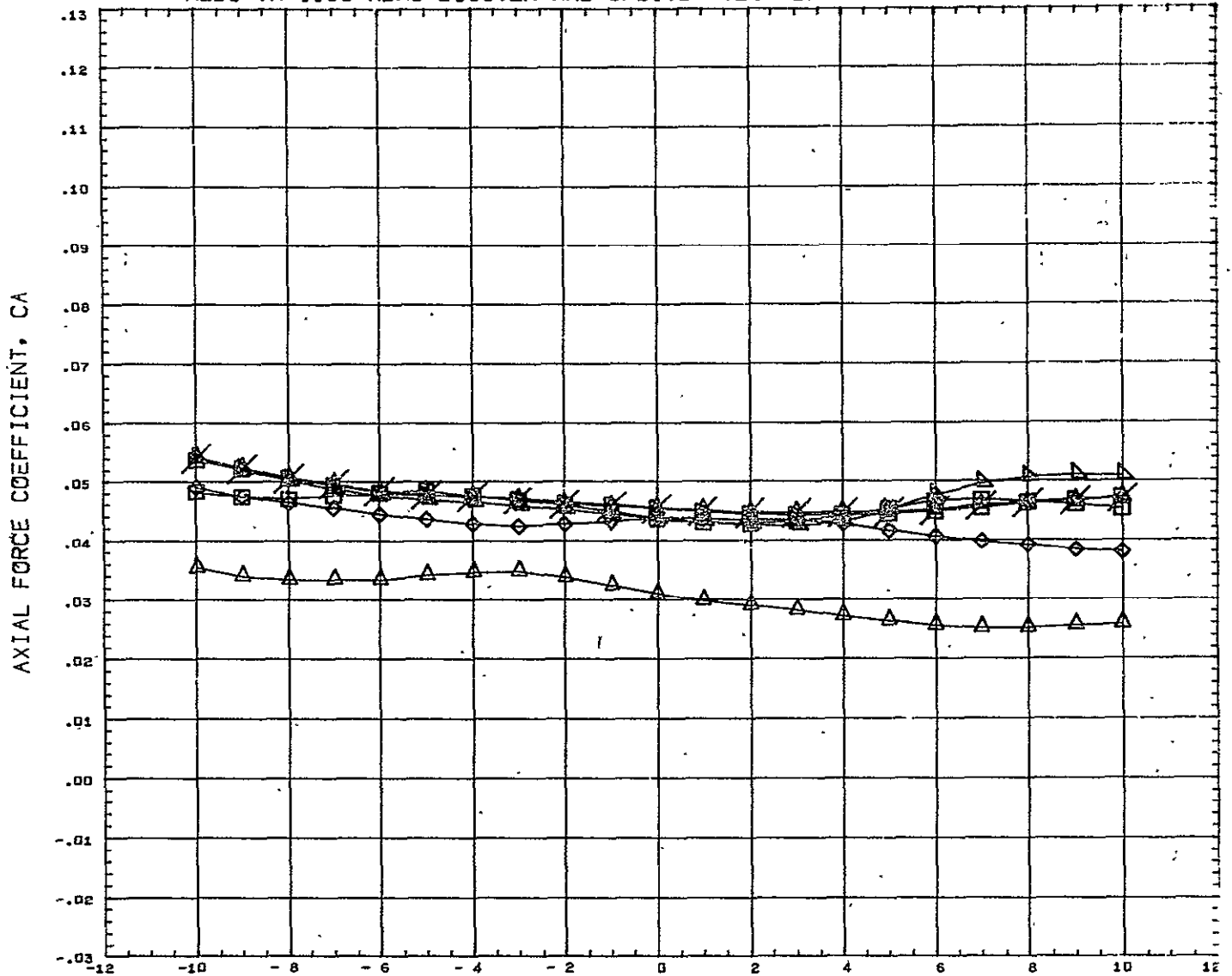

SYMBOL △ ◇ □ ×	DELTAZ 0.151 0.182 0.228 0.352 0.599 10.000	<table border="0" style="width: 100%;"> <tr> <th colspan="4" style="text-align: center;">PARAMETRIC VALUES</th> </tr> <tr> <td>BSTPOW</td><td>50.000</td><td>ORBPOW</td><td>100.000</td> </tr> <tr> <td>DELTAZ</td><td>0.143</td><td>ALPHA1</td><td>5.100</td> </tr> <tr> <td>MACH</td><td>5.010</td><td>ELVBST</td><td>0.000</td> </tr> <tr> <td>ELVORB</td><td>0.000</td><td>BETA</td><td>0.000</td> </tr> </table>	PARAMETRIC VALUES				BSTPOW	50.000	ORBPOW	100.000	DELTAZ	0.143	ALPHA1	5.100	MACH	5.010	ELVBST	0.000	ELVORB	0.000	BETA	0.000	<table border="0" style="width: 100%;"> <tr> <th colspan="3" style="text-align: center;">REFERENCE INFORMATION</th> </tr> <tr> <td>REFS</td><td>23.6890</td><td>SQ IN</td> </tr> <tr> <td>REFL</td><td>4.1930</td><td>IN</td> </tr> <tr> <td>REFB</td><td>6.5000</td><td>IN</td> </tr> <tr> <td>XMRP</td><td>4.9170</td><td>IN</td> </tr> <tr> <td>YMRP</td><td>0.0000</td><td>IN</td> </tr> <tr> <td>ZMRP</td><td>1.3970</td><td>IN</td> </tr> <tr> <td>SCALE</td><td>0.0055</td><td></td> </tr> </table>	REFERENCE INFORMATION			REFS	23.6890	SQ IN	REFL	4.1930	IN	REFB	6.5000	IN	XMRP	4.9170	IN	YMRP	0.0000	IN	ZMRP	1.3970	IN	SCALE	0.0055	
PARAMETRIC VALUES																																															
BSTPOW	50.000	ORBPOW	100.000																																												
DELTAZ	0.143	ALPHA1	5.100																																												
MACH	5.010	ELVBST	0.000																																												
ELVORB	0.000	BETA	0.000																																												
REFERENCE INFORMATION																																															
REFS	23.6890	SQ IN																																													
REFL	4.1930	IN																																													
REFB	6.5000	IN																																													
XMRP	4.9170	IN																																													
YMRP	0.0000	IN																																													
ZMRP	1.3970	IN																																													
SCALE	0.0055																																														

REFERENCE FILE

# AEDC VA 1163 MDAC BOOSTER AND ORBITER TEST DATA AT MACH NUMBER 5

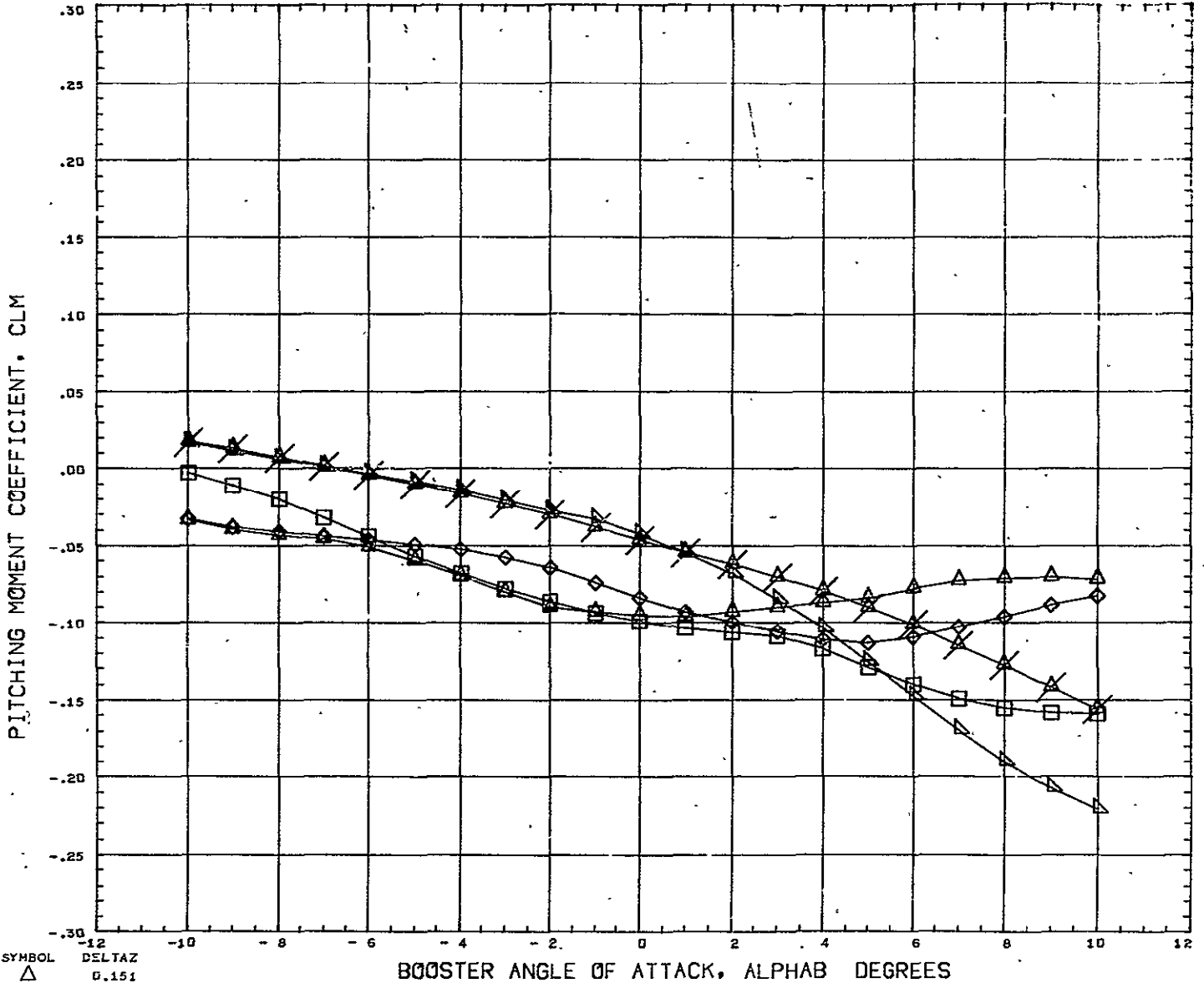

SYMBOL △ ◇ □ ×	DELTA Z 0.151 0.182 0.228 0.352 10.000	PARAMETRIC VALUES BSTPOW 50.000 ORBPOW 100.000 DELTAX - 0.019 ALPHAI 5.100 MACH 5.010 ELVBST 0.000 ELVORB 0.000 BETA 0.900	REFERENCE INFORMATION REFS 23.6890 SQ IN REFL 4.1930 IN REFB 6.5000 IN XMRF 4.5170 IN YMRF 0.0000 IN ZMRF 1.3900 IN SCALE 0.0055
----------------------------	---	--	---

REFERENCE FILE

# AEDC VA 1163 MDAC BOOSTER AND ORBITER TEST DATA AT MACH NUMBER 5

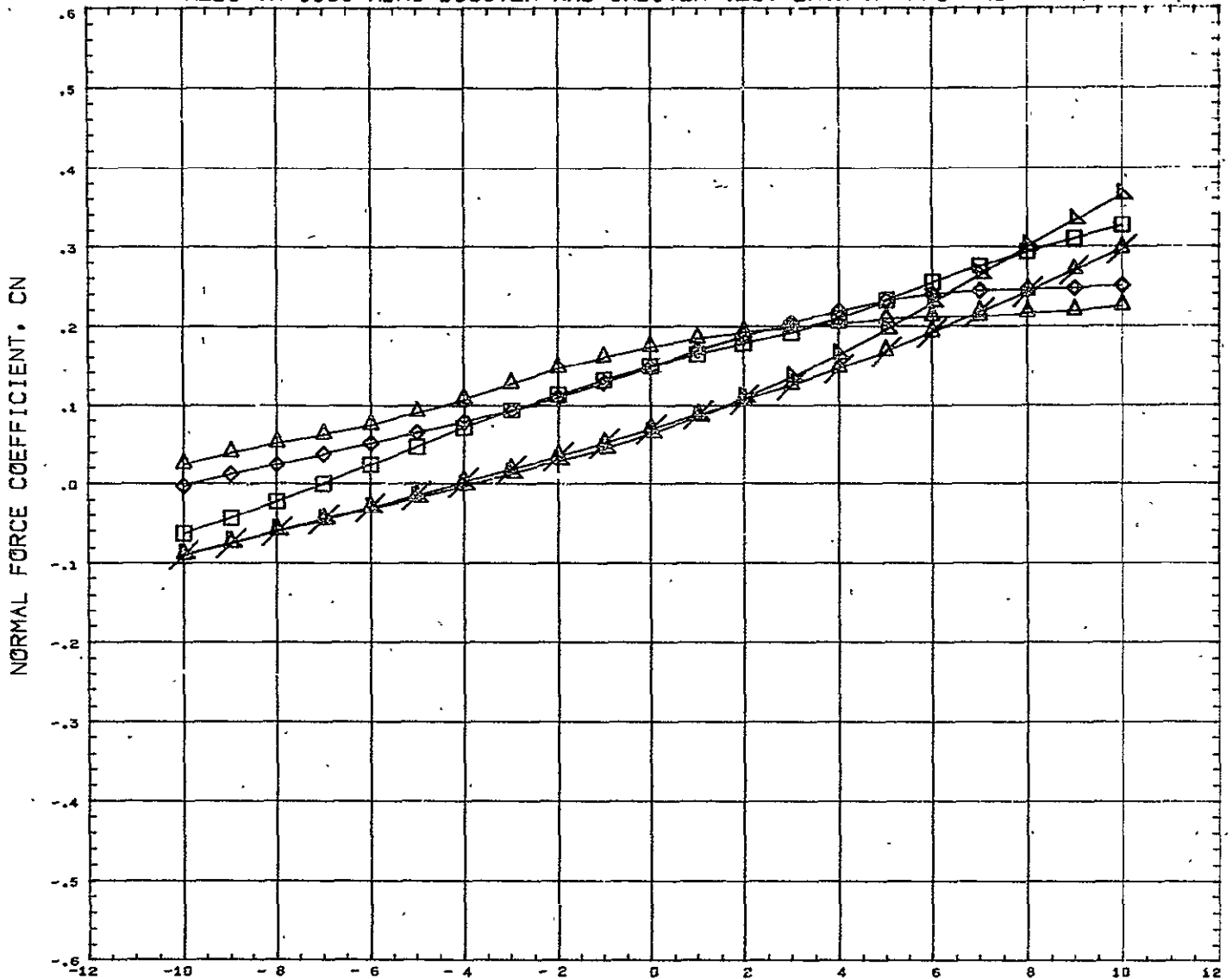

SYMBOL △ ◇ □ ○ ×	DELTAZ 0.151 0.182 0.228 0.352 10.000	PARAMETRIC VALUES BSTPCW 50.000 ORBPCW 100.000 DELTAX - 0.019 ALPHAI 5.100 MACH 5.010 ELVBST 0.000 ELVORB 0.000 BETA 0.000	REFERENCE INFORMATION REFS 23.6890 SQ IN REFL 4.1930 IN REFB 6.5000 IN XMRP 4.2170 IN YMRP 0.0000 IN ZMRP 1.3900 IN SCALE 0.0055
---------------------------------	--	--	---

REFERENCE FILE

# AEDC VA 1163 MDAC BOOSTER AND ORBITER TEST DATA AT MACH NUMBER 5

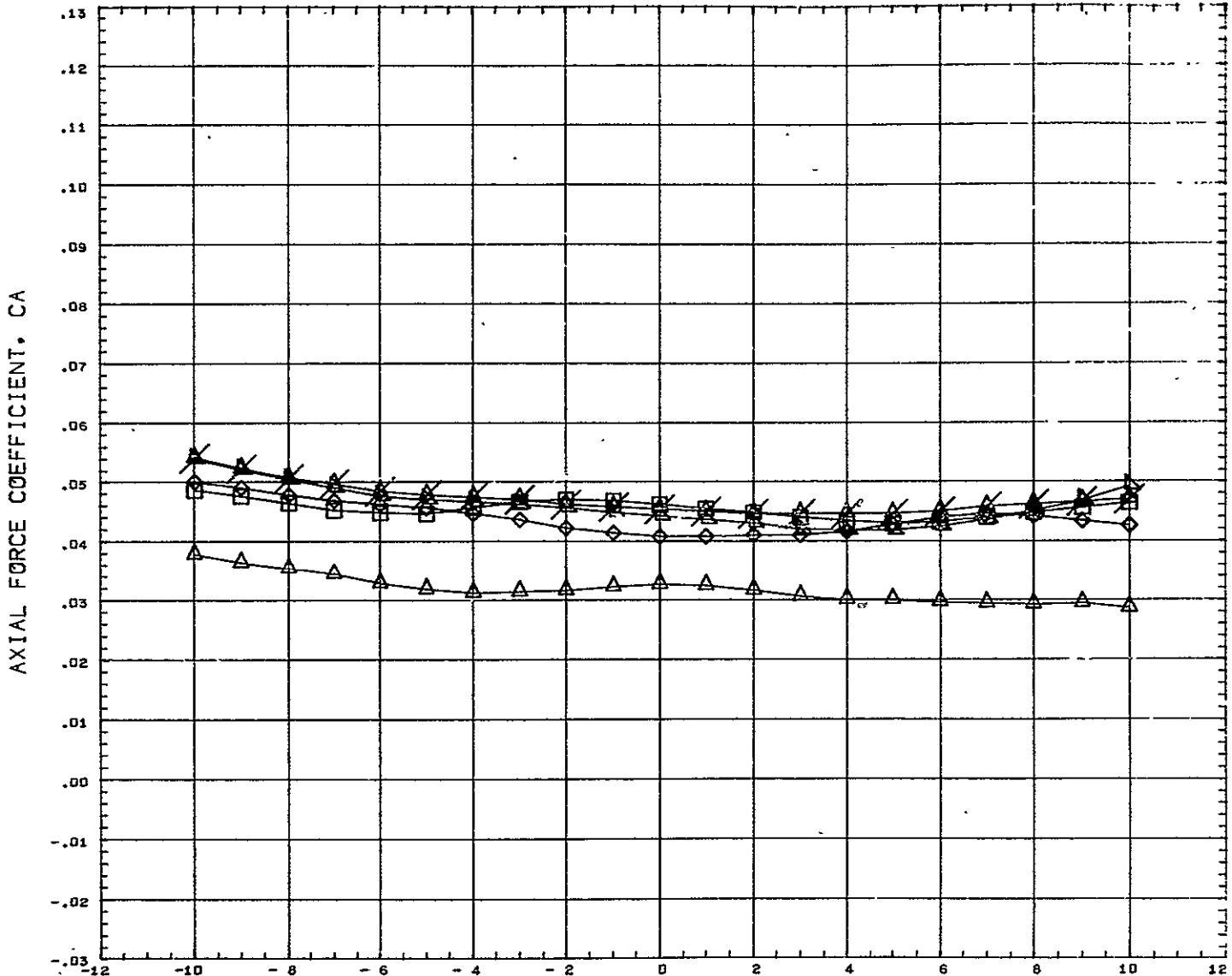

SYMBOL △ ◇ □ ×	DELTAZ 0.151 0.182 0.228 0.352 10.000	PARAMETRIC VALUES BSTFOW 50.000 ORBFOV 100.000 DELTAX - 0.019 ALPHAI 5.100 MACH 5.010 ELVST 0.000 ELVORB 0.000 BETA 0.000	REFERENCE INFORMATION REFS 23.6890 SQ IN REFL 4.1930 IN REFB 6.5000 IN XMRP 4.9176 IN YMRP 0.0000 IN ZMRP 1.3900 IN SCALE 0.0055
----------------------------	--	---	---

REFERENCE FILE

AEDC VA 1163 MDAC BOOSTER AND ORBITER TEST DATA AT MACH NUMBER 5

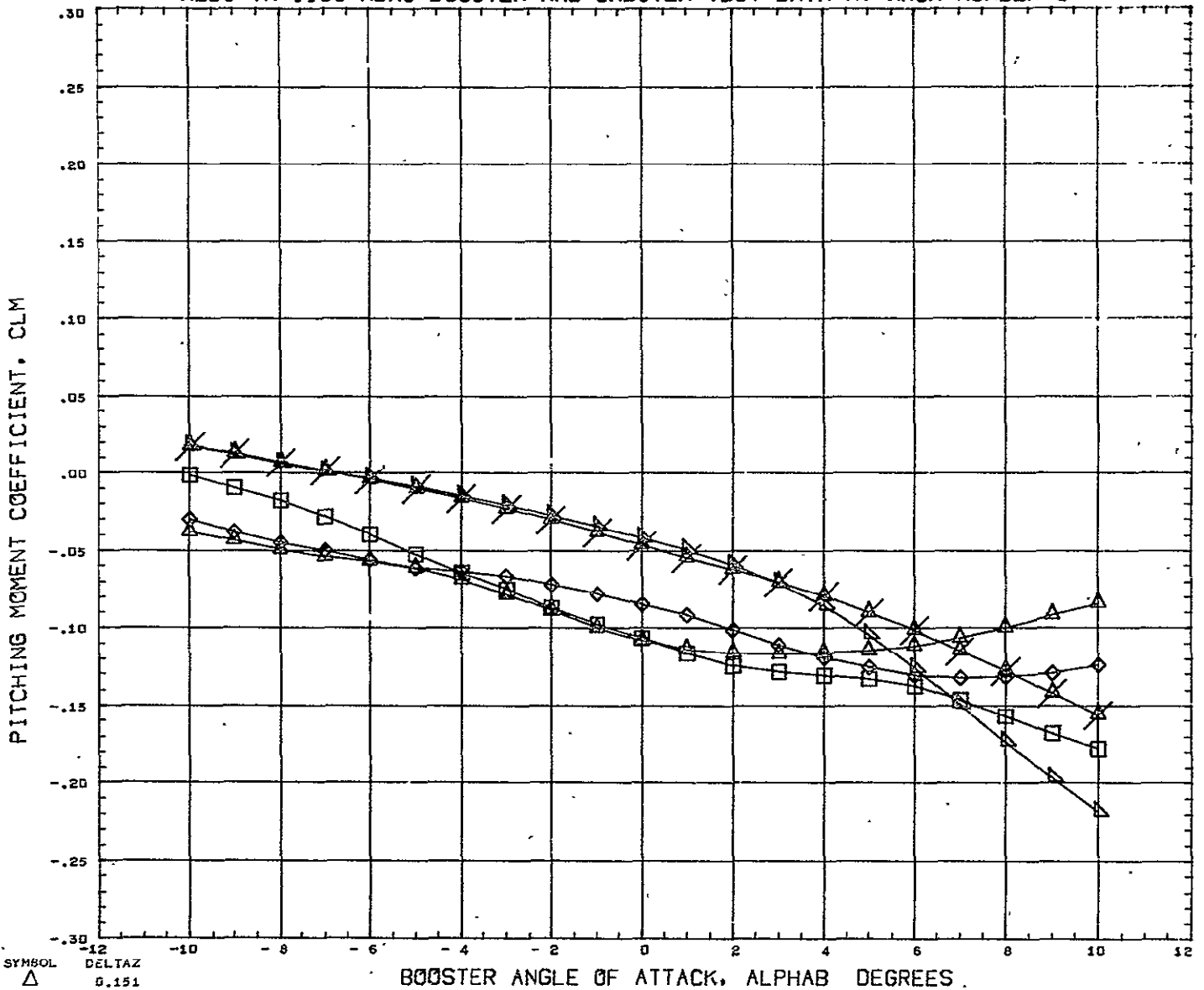

SYMBOL	DELTA Z	PARAMETRIC VALUES		REFERENCE INFORMATION					
△	0.151	BSTPOW	50.000	ORBPOW	100.000	REFS	23.6890	SG	IN
□	0.192	DELTA X	0.043	ALPHA I	5.100	REFL	4.1930	IN	
◇	0.220	MACH	5.010	ELVBST	0.000	REFB	6.5000	IN	
×	10.000	ELVORB	0.000	BETA	0.100	XMRP	4.9170	IN	
▽						YMRP	0.0000	IN	
						ZMRP	1.3900	IN	
						SCALE	0.0055		

REFERENCE FILE

# AEDC VA 1163 MDAC BOOSTER AND ORBITER TEST DATA AT MACH NUMBER 5

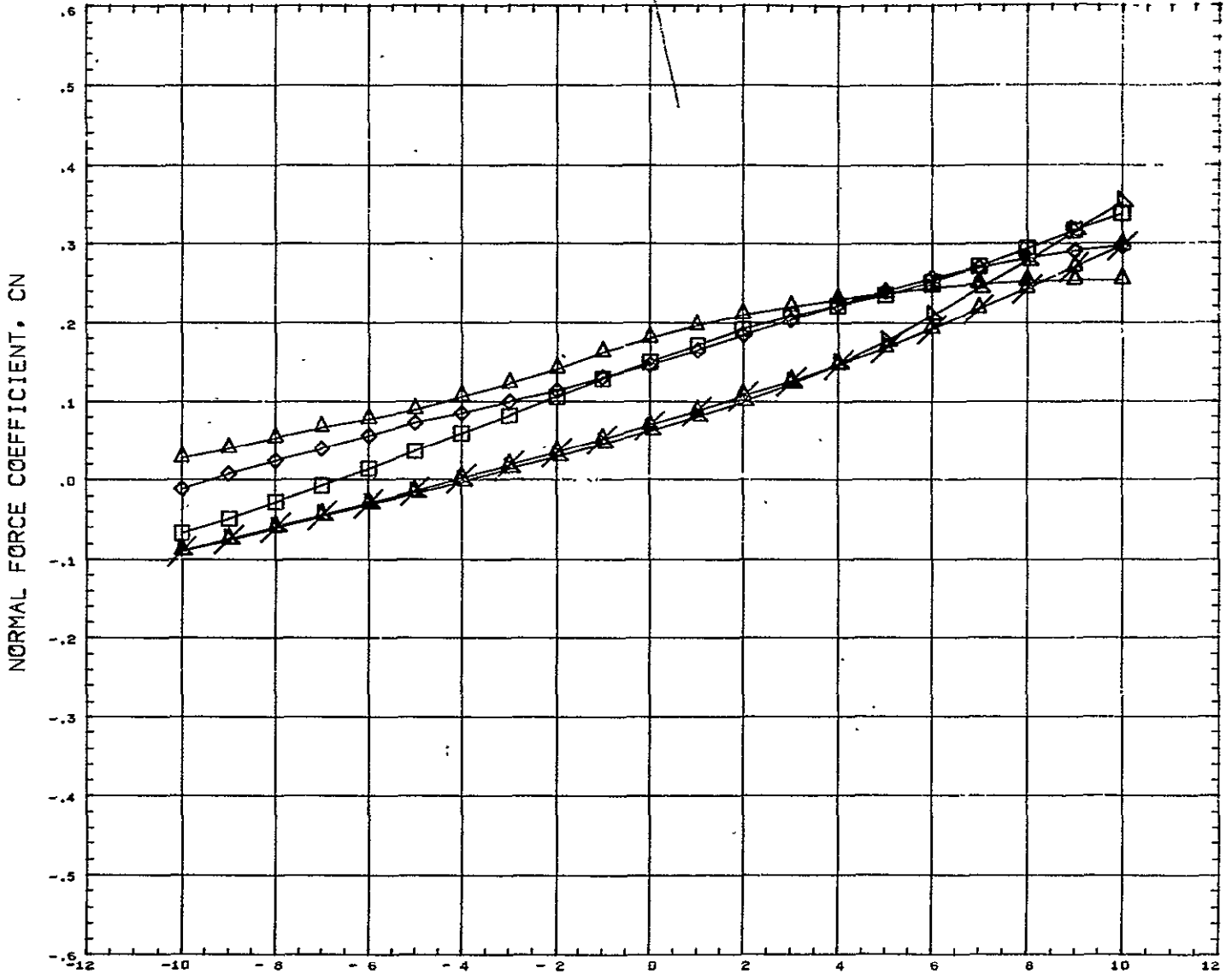

SYMBOL △ ◇ □ ○ ×	DELTAZ 0.151 0.182 0.228 0.352 10.000	PARAMETRIC VALUES BSTPOW 50.000 ORBPOW 100.000 DELTAX 0.043 ALPHAI 5.100 MACH 5.010 ELVBST 0.000 ELVORB 0.000 BETA 0.000	REFERENCE INFORMATION REFS 23.6890 SQ IN REFL 4.1930 IN REFB 6.5000 IN XMRP 4.9170 IN YMRP 0.0000 IN ZMRP 1.3990 IN SCALE 0.0055
---------------------------------	--	--	---

REFERENCE FILE



# AEDC VA. 1163 MDAC BOOSTER AND ORBITER TEST DATA AT MACH NUMBER 5

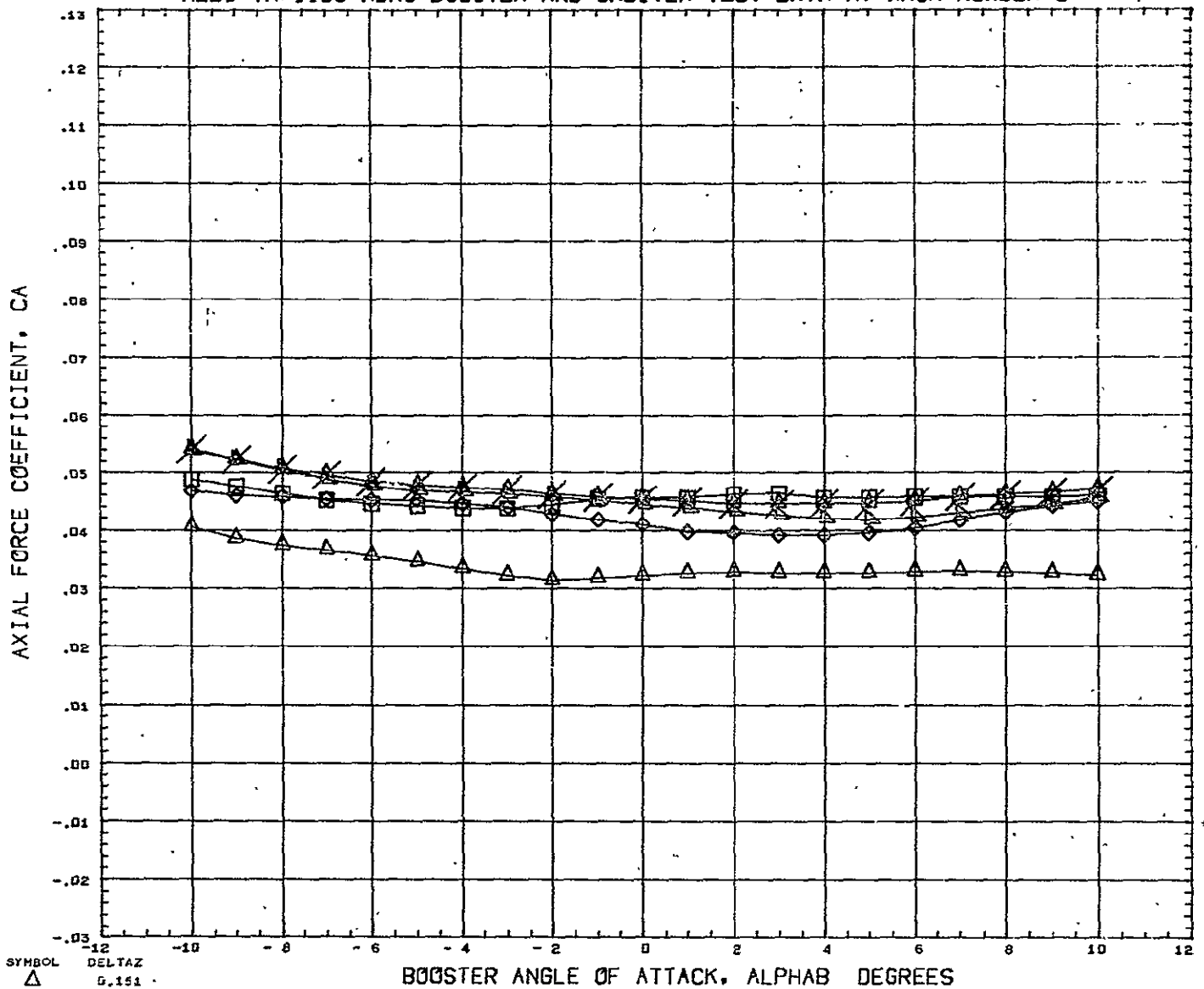

SYMBOL △ ◇ □ ×	DELTAZ 0.151 0.182 0.228 0.352 10.000	PARAMETRIC VALUES BSTFOW 50.000 ORBFW 100.000 DELTAX 0.043 ALPHAI 5.100 MACH 5.010 ELVBST 0.000 ELVORB 0.000 BETA 0.000	REFERENCE INFORMATION REFS 23.6850 SQ IN REFL 4.1930 IN REFB 6.5000 IN XMRF 4.9170 IN YMRP 0.0000 IN ZMRP 1.3900 IN SCALE 0.0055
----------------------------	--	---	---

REFERENCE FILE

# AEDC VA 1163 MDAC BOOSTER AND ORBITER TEST DATA AT MACH NUMBER 5

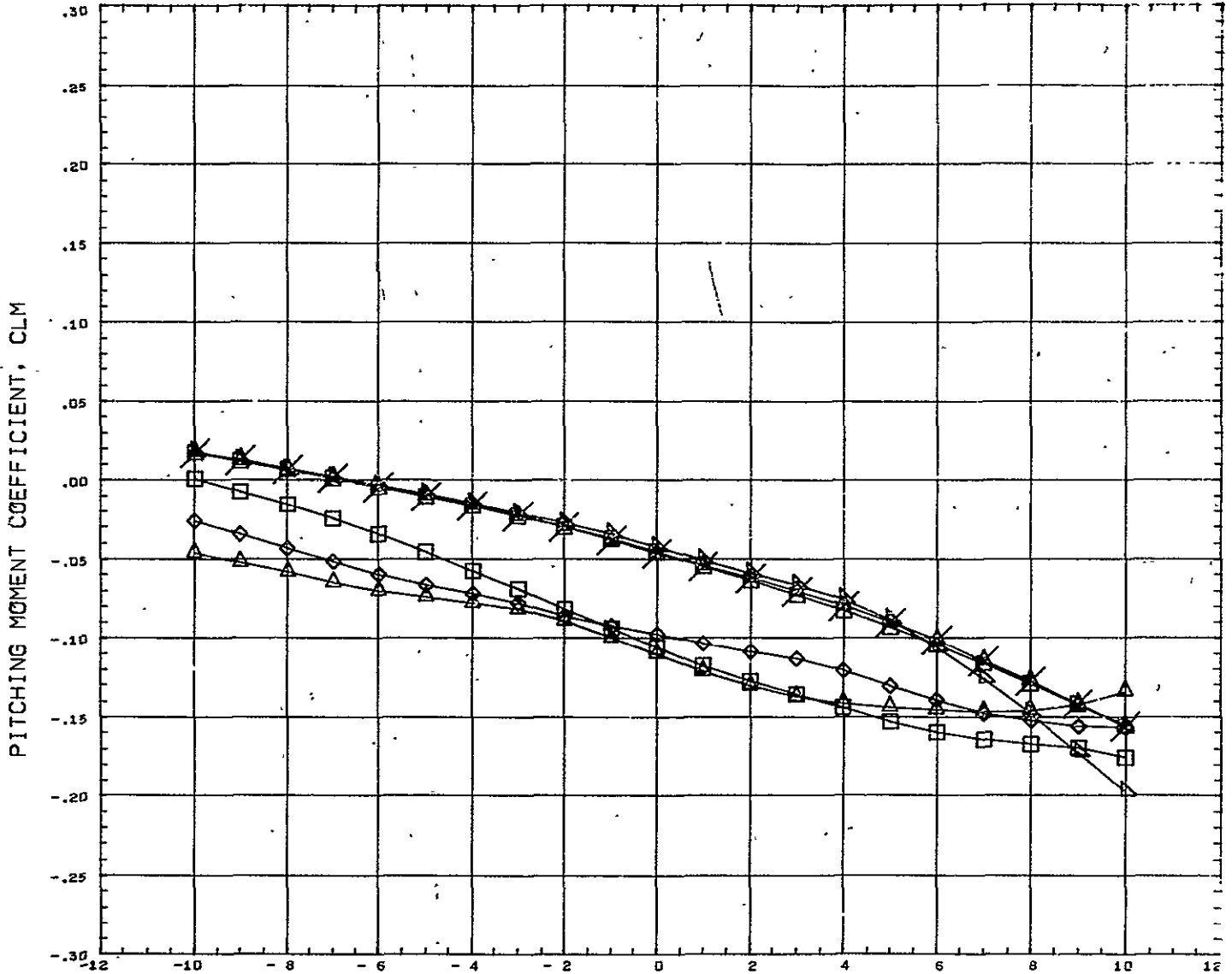

SYMBOL ◻ ◊ △ ▽ ×	DELTAZ 0.151 0.102 0.226 0.352 0.599 10.000	PARAMETRIC VALUES BSTPOW 50.000 ORBPOW 100.000 DELTAX 0.105 ALPHAI 5.100 MACH 5.010 ELVBST 0.000 ELVORB 0.000 BETA 0.000	REFERENCE INFORMATION REFS 23.6890 SQ IN REFL 4.1930 IN REFB 6.5000 IN XMRP 4.9170 IN YMRP 0.0000 IN ZMRP 1.3900 IN SCALE 0.0055
---------------------------------	---	--	---

REFERENCE FILE

# AEDC VA 1163 MDAC BOOSTER AND ORBITER TEST DATA AT MACH NUMBER 5

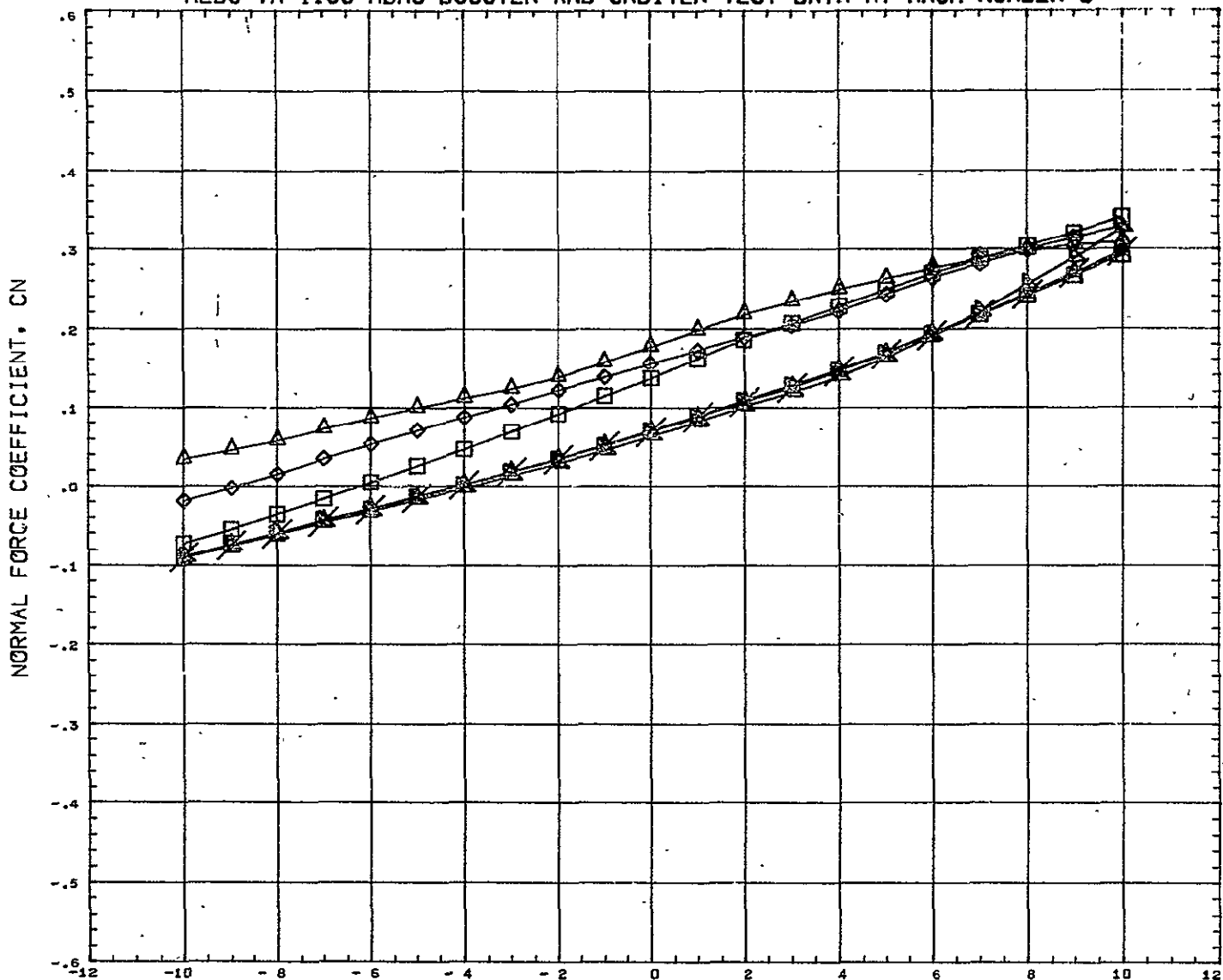

SYMBOL △ ◇ □ ○ ×	DELTA Z 0.151 0.182 0.228 0.352 0.599 10.000	PARAMETRIC VALUES BSTFOW 50.000 ORBPOW 100.000 DELTAX 0.105 ALPHAI 5.100 MACH 5.010 ELVBST 0.000 ELVORB 0.000 BETA 0.000	REFERENCE INFORMATION REFS 23.6890 SQ IN REFL 4.1930 IN REFB 6.5000 IN XMRP 4.9170 IN YMRP 0.0000 IN ZMRP 1.3900 IN SCALE 0.0055
---------------------------------	--	--	---

REFERENCE FILE .

# AEDC VA 1163 MDAC BOOSTER AND ORBITER TEST DATA AT MACH NUMBER 5

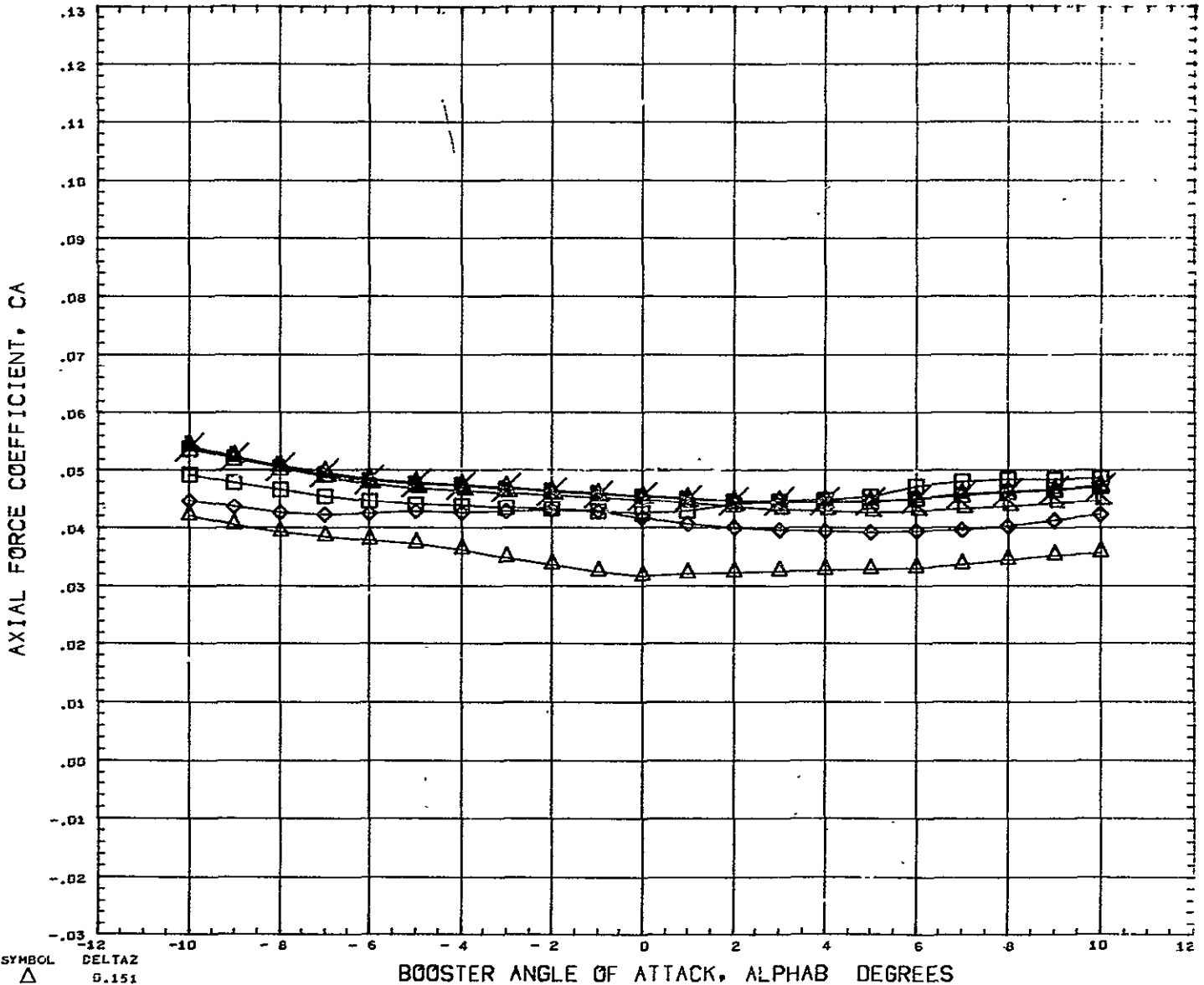

SYMBOL ◊ ◊ ◊ ◊ ◊	DELTAZ 0.151 0.182 0.228 0.352 0.599 10.000	PARAMETRIC VALUES BSTPOW 50.000 ORBPOW 100.000 DELTAX 0.105 ALPHAI 5.100 MACH 5.010 ELVBST 0.000 ELVORB 0.000 BETA 0.000	REFERENCE INFORMATION REFS 23.6890 SQ IN REFL 4.1930 IN REFD 6.5000 IN XMRP 4.9170 IN YMRP 0.0000 IN ZMRP 1.3900 IN SCALE 0.0055
---------------------------------	---	--	---

REFERENCE FILE

# AEDC VA 1163 MDAC BOOSTER AND ORBITER TEST DATA AT MACH NUMBER 5

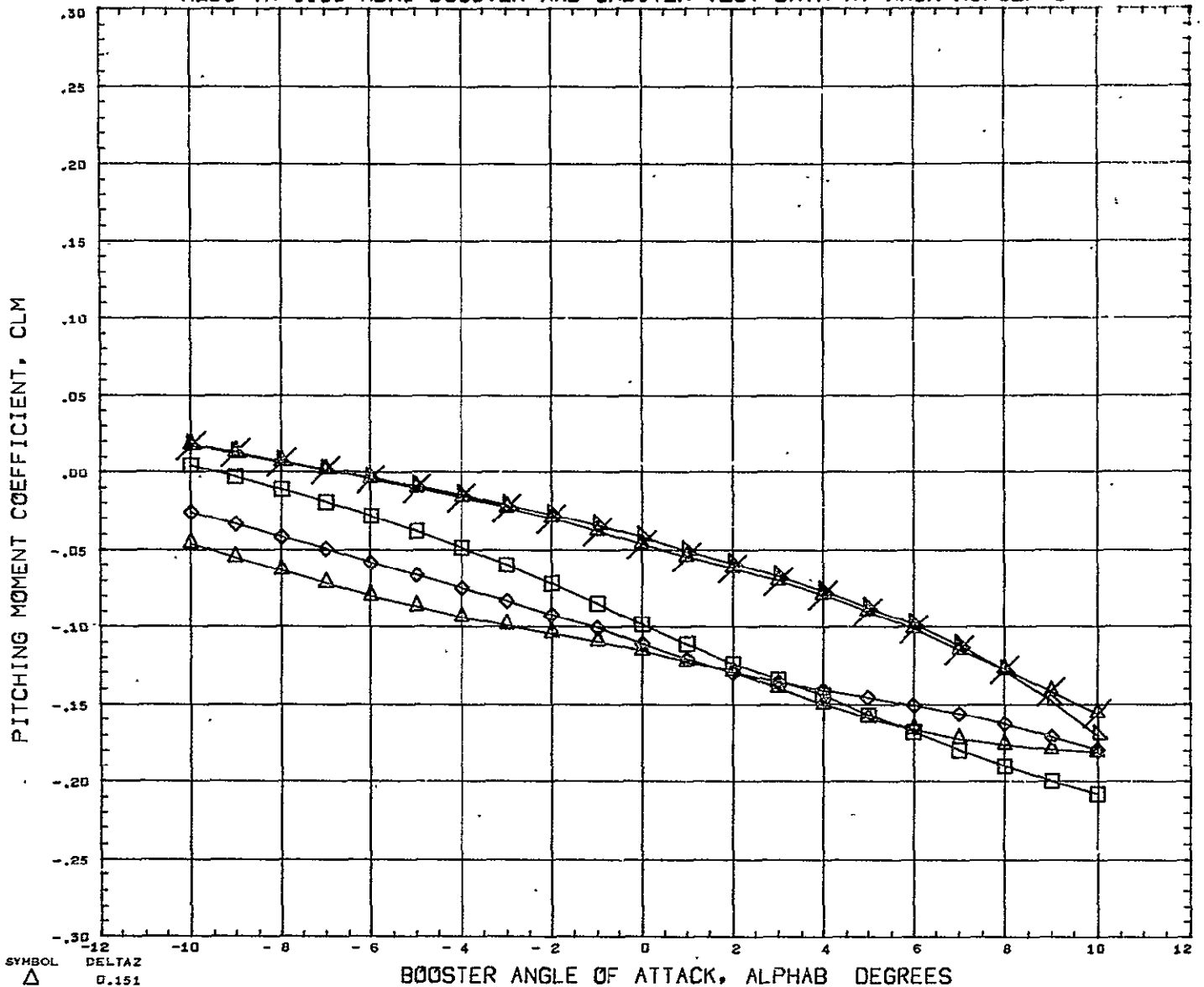

SYMBOL	DELTAZ	PARAMETRIC VALUES				REFERENCE INFORMATION		
△	0.151	BSTPOW	50.000	ORBPOW	100.000	REFS	23.6890	SQ IN
◇	0.182	DELTAZ	0.167	ALPHA1	5.100	REFL	4.1930	IN
□	0.228	MACH	5.010	ELVBST	0.000	REFB	6.5000	IN
○	0.352	ELVORB	0.000	BETA	0.070	XMRP	4.9170	IN
×	10.000					YMRP	0.0000	IN
						ZMRP	1.3900	IN
						SCALE	0.0055	IN

REFERENCE FILE

# AEDC VA 1163 MDAC BOOSTER AND ORBITER TEST DATA AT MACH NUMBER 5

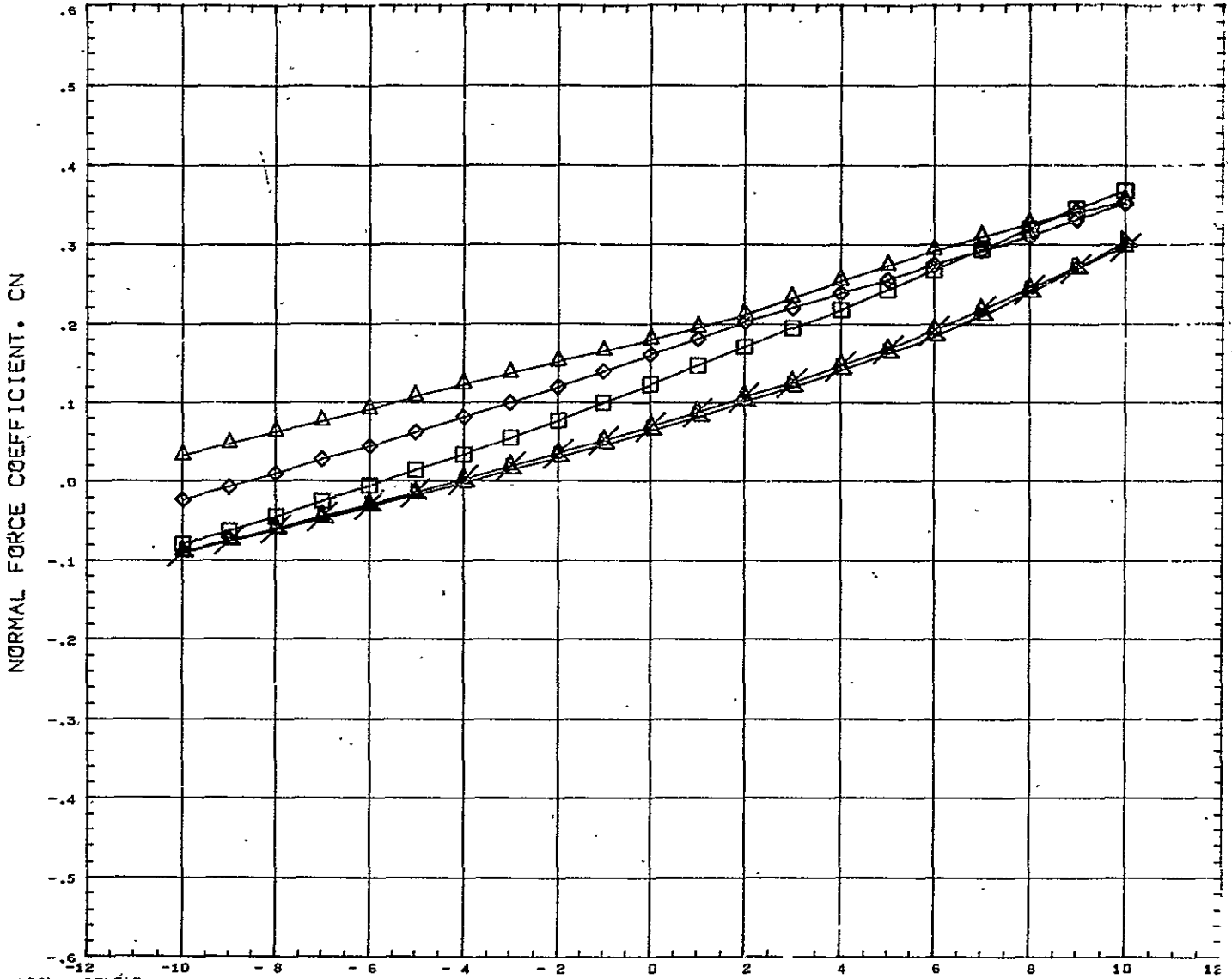

SYMBOL △ ◇ □ ×	DELTAZ 0.151 0.162 0.228 0.352 10.000	<b>PARAMETRIC VALUES</b> BSTPOW 50.000 ORBPOW 100.000 DELTAX 0.167 ALPHAI 5.100 MACH 5.010 ELVBST 0.000 ELVORB 0.000 BETA 0.000	<b>REFERENCE INFORMATION</b> REFS 23.6890 SQ IN REFL 4.1930 IN REFB 6.5000 IN XNRF 4.9170 IN YNRF 0.0500 IN ZNRF 1.3900 IN SCALE 0.0055
REFERENCE FILE			

# AEDC VA 1163 MDAC BOOSTER AND ORBITER TEST DATA AT MACH NUMBER 5

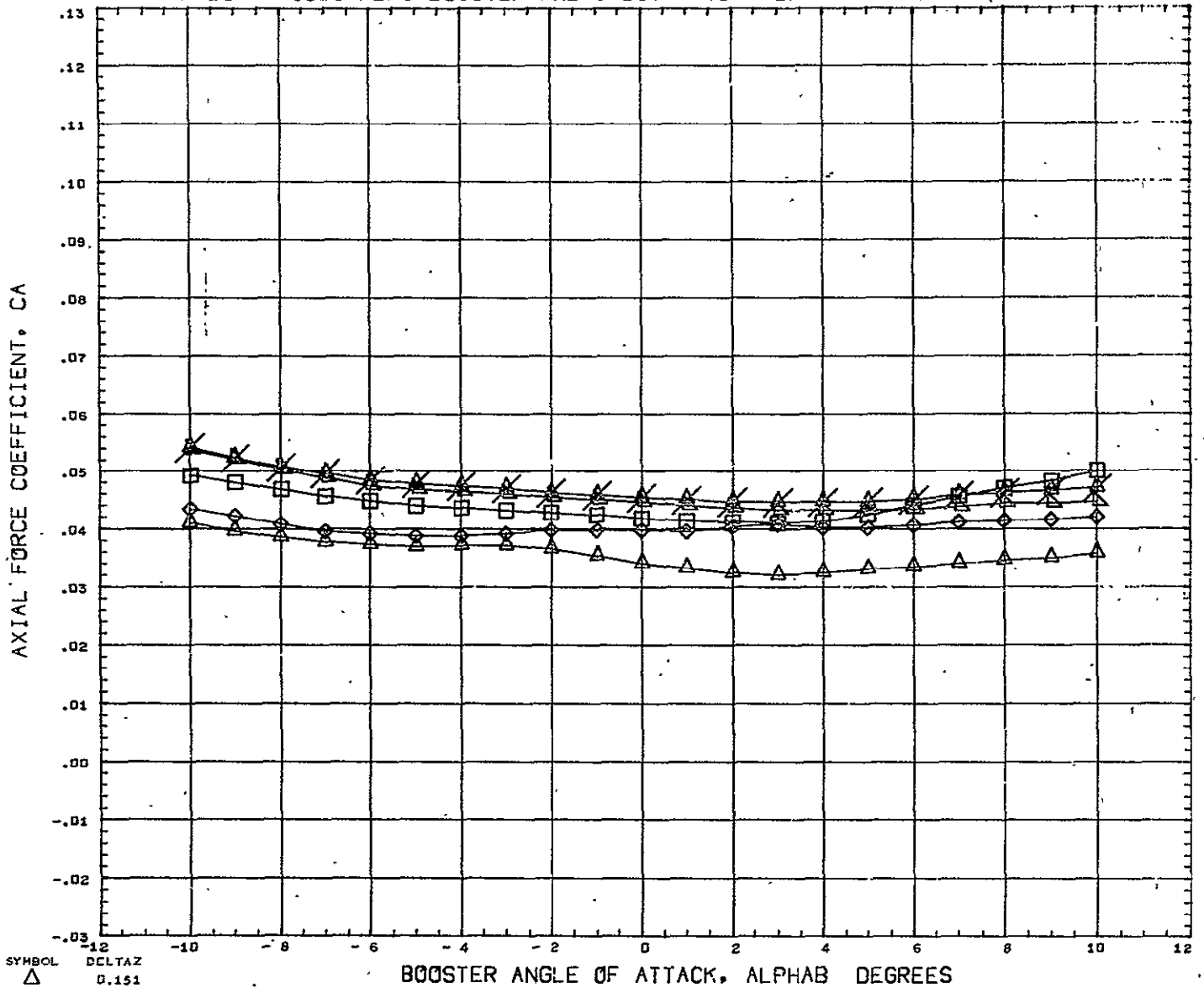

SYMBOL ◻ ◊ △ ▽	DELTAZ 0.151 0.182 0.228 0.352 10.000	PARAMETRIC VALUES BSTFOW 50.000 ORBFOV 100.000 DELTAX 0.167 ALPHAI 5.100 MACH 5.010 ELVBST 0.000 ELVORB 0.000 BETA 0.000	REFERENCE INFORMATION REFS 23.6890 SQ, IN REFL 4.1930 IN REFB 6.5000 IN XMRP 4.9170 IN YMRP 0.0000 IN ZMRP 1.3900 IN SCALE 0.0055
----------------------------	--	--	--

REFERENCE FILE

# AEDC VA 1163 MDAC BOOSTER AND ORBITER TEST DATA AT MACH NUMBER 5

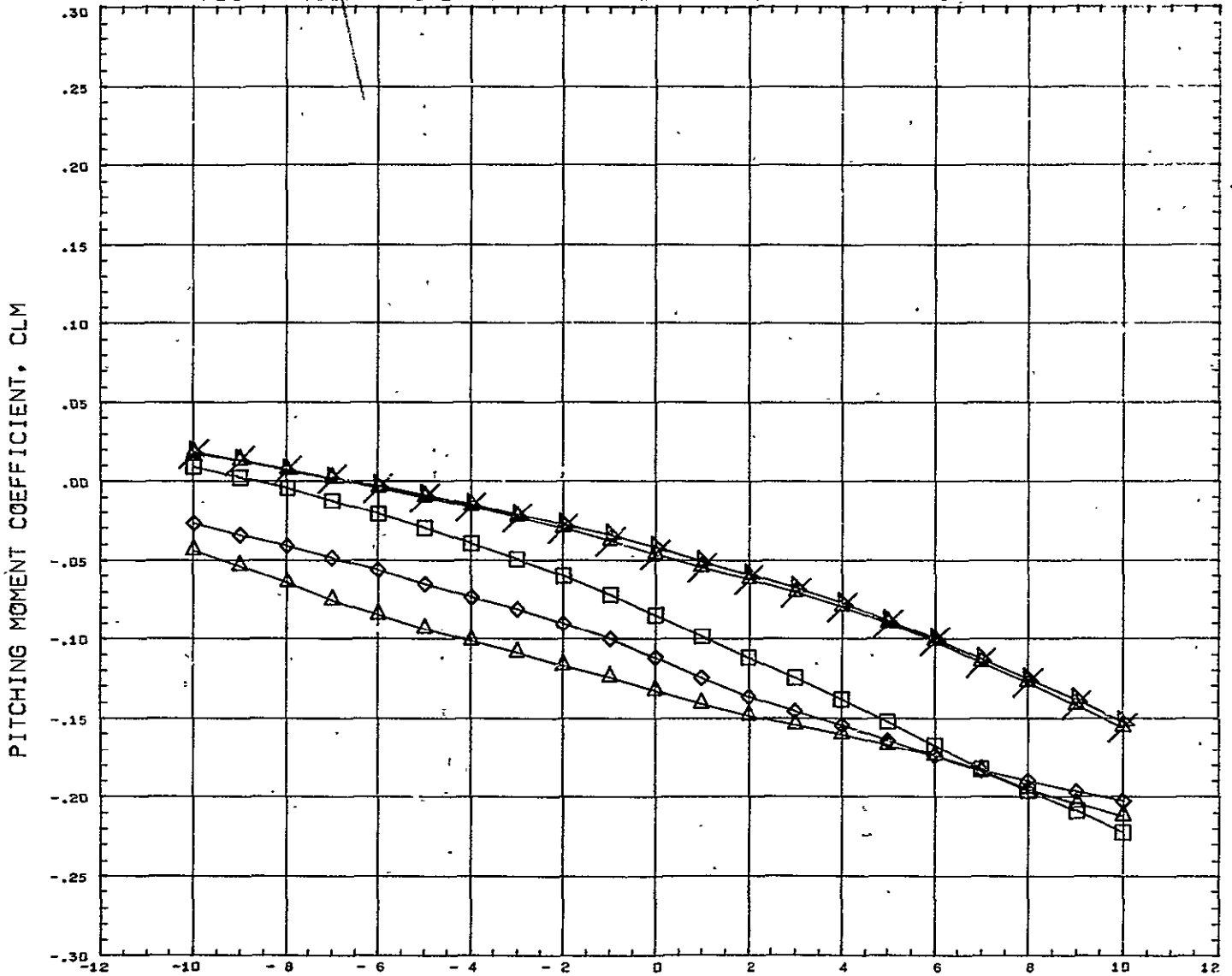

SYMBOL △ ◇ □ ×	DELTAZ 0.151 0.182 0.228 0.352 10.000	<table border="0" style="width: 100%;"> <tr> <th colspan="4" style="text-align: left; padding-left: 20px;">PARAMETRIC VALUES</th> </tr> <tr> <td style="padding-right: 20px;">BSTFOW</td> <td>50.000</td> <td style="padding-right: 20px;">ORBPOW</td> <td>100.000</td> </tr> <tr> <td style="padding-right: 20px;">DELTA X</td> <td>0.228</td> <td style="padding-right: 20px;">ALPHA I</td> <td>5.100</td> </tr> <tr> <td style="padding-right: 20px;">MACH</td> <td>5.010</td> <td style="padding-right: 20px;">ELVBST</td> <td>0.000</td> </tr> <tr> <td style="padding-right: 20px;">ELVORB</td> <td>0.000</td> <td style="padding-right: 20px;">BETA</td> <td>0.000</td> </tr> </table>	PARAMETRIC VALUES				BSTFOW	50.000	ORBPOW	100.000	DELTA X	0.228	ALPHA I	5.100	MACH	5.010	ELVBST	0.000	ELVORB	0.000	BETA	0.000	<table border="0" style="width: 100%;"> <tr> <th colspan="3" style="text-align: left;">REFERENCE INFORMATION</th> </tr> <tr> <td style="padding-right: 20px;">REFS</td> <td>23.6890</td> <td>SQ IN</td> </tr> <tr> <td style="padding-right: 20px;">REFL</td> <td>4.1930</td> <td>IN</td> </tr> <tr> <td style="padding-right: 20px;">REFB</td> <td>6.5000</td> <td>IN</td> </tr> <tr> <td style="padding-right: 20px;">XMR<sup>o</sup></td> <td>4.9170</td> <td>IN</td> </tr> <tr> <td style="padding-right: 20px;">YMRP</td> <td>0.0000</td> <td>IN</td> </tr> <tr> <td style="padding-right: 20px;">ZMRP</td> <td>1.3900</td> <td>IN</td> </tr> <tr> <td style="padding-right: 20px;">SCALE</td> <td>0.0055</td> <td></td> </tr> </table>	REFERENCE INFORMATION			REFS	23.6890	SQ IN	REFL	4.1930	IN	REFB	6.5000	IN	XMR <sup>o</sup>	4.9170	IN	YMRP	0.0000	IN	ZMRP	1.3900	IN	SCALE	0.0055	
PARAMETRIC VALUES																																															
BSTFOW	50.000	ORBPOW	100.000																																												
DELTA X	0.228	ALPHA I	5.100																																												
MACH	5.010	ELVBST	0.000																																												
ELVORB	0.000	BETA	0.000																																												
REFERENCE INFORMATION																																															
REFS	23.6890	SQ IN																																													
REFL	4.1930	IN																																													
REFB	6.5000	IN																																													
XMR <sup>o</sup>	4.9170	IN																																													
YMRP	0.0000	IN																																													
ZMRP	1.3900	IN																																													
SCALE	0.0055																																														

REFERENCE FILE



# AEDC VA 1163 MDAC BOOSTER AND ORBITER TEST DATA AT MACH NUMBER 5

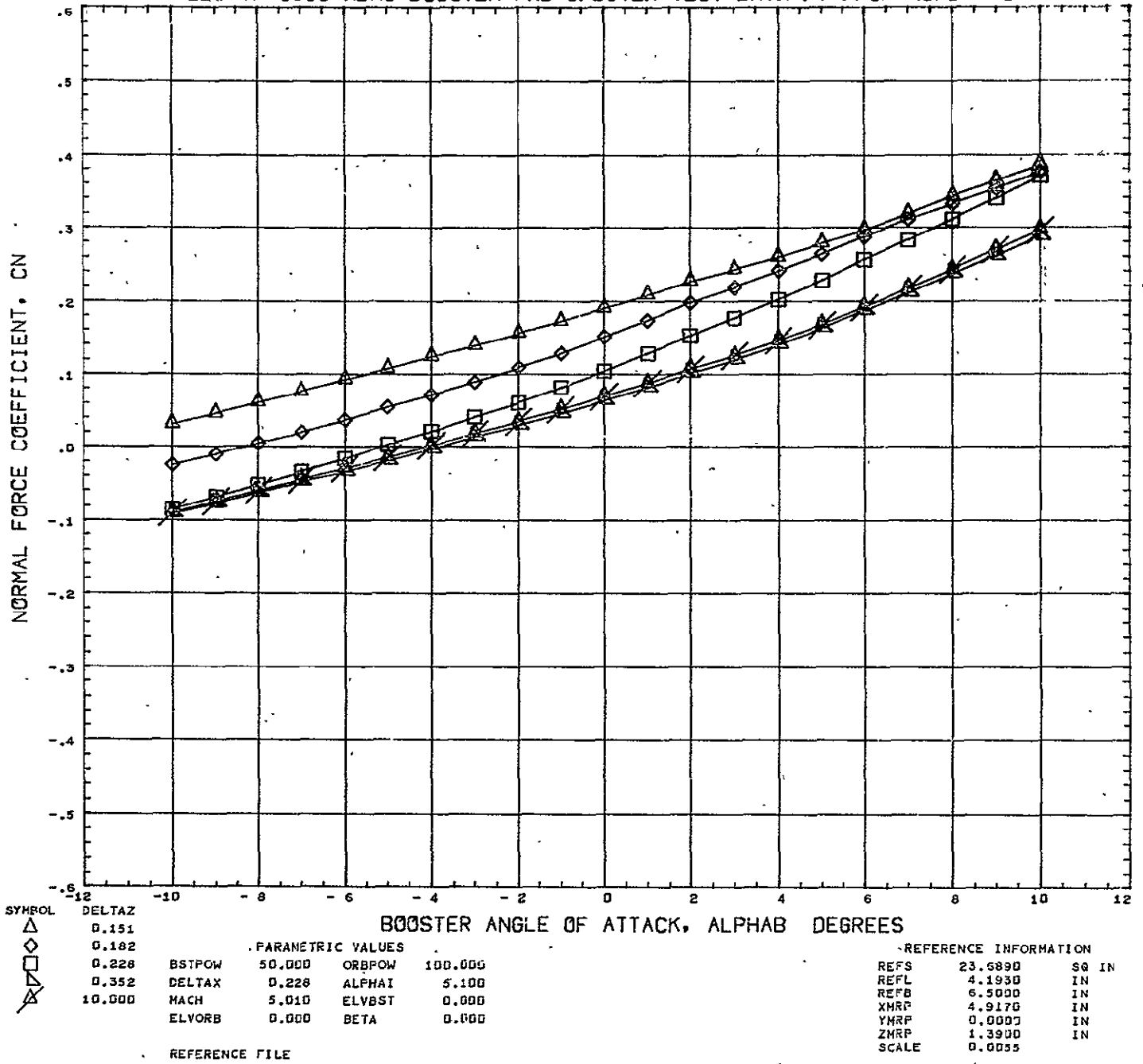

SYMBOL △ ◇ □ ▽	DELTAZ 0.151 0.182 0.228 0.352 10.000	PARAMETRIC VALUES BSTPOW 50.000 ORBPOW 100.000 DELTAX 0.228 ALPHAI 5.100 MACH 5.010 ELVBST 0.000 ELVORB 0.000 BETA 0.000	REFERENCE INFORMATION REFS 23.6890 SQ IN REFL 4.1930 IN REFB 6.5000 IN XMRP 4.9170 IN YMRP 0.0000 IN ZMRP 1.3900 IN SCALE 0.0055
----------------------------	--	--	---

# AEDC VA 1163 MDAC BOOSTER AND ORBITER TEST DATA AT MACH NUMBER 5

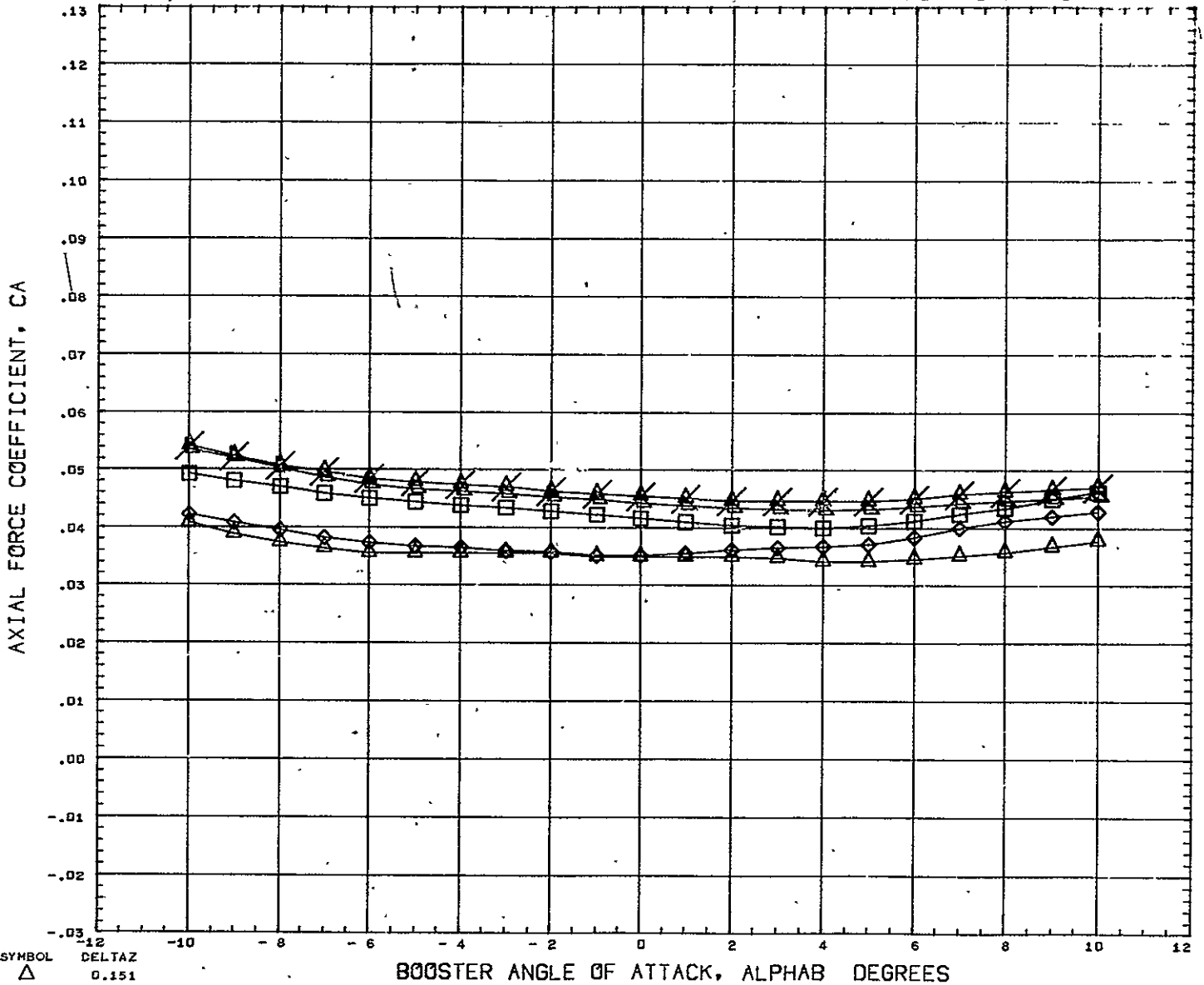

SYMBOL ◻ ◻ ◻ ◻ ◻	DELTAX 0.151 0.182 0.228 0.352 10.000	<table border="0" style="width: 100%;"> <tr> <th colspan="4" style="text-align: center;">PARAMETRIC VALUES</th> </tr> <tr> <td>BSTPOW</td><td>50.000</td><td>ORBPOW</td><td>100.000</td> </tr> <tr> <td>DELTAX</td><td>0.228</td><td>ALPHAI</td><td>5.100</td> </tr> <tr> <td>MACH</td><td>5.010</td><td>ELVBST</td><td>0.000</td> </tr> <tr> <td>ELVORB</td><td>0.000</td><td>BETA</td><td>0.000</td> </tr> </table>	PARAMETRIC VALUES				BSTPOW	50.000	ORBPOW	100.000	DELTAX	0.228	ALPHAI	5.100	MACH	5.010	ELVBST	0.000	ELVORB	0.000	BETA	0.000	<table border="0" style="width: 100%;"> <tr> <th colspan="3" style="text-align: center;">REFERENCE INFORMATION</th> </tr> <tr> <td>REFS</td><td>23.6890</td><td>SQ IN</td> </tr> <tr> <td>REFL</td><td>4.1930</td><td>IN</td> </tr> <tr> <td>REFB</td><td>6.5000</td><td>IN</td> </tr> <tr> <td>XMRP</td><td>4.9170</td><td>IN</td> </tr> <tr> <td>YMRP</td><td>0.0000</td><td>IN</td> </tr> <tr> <td>ZMRP</td><td>1.3900</td><td>IN</td> </tr> <tr> <td>SCALE</td><td>0.0055</td><td></td> </tr> </table>	REFERENCE INFORMATION			REFS	23.6890	SQ IN	REFL	4.1930	IN	REFB	6.5000	IN	XMRP	4.9170	IN	YMRP	0.0000	IN	ZMRP	1.3900	IN	SCALE	0.0055	
PARAMETRIC VALUES																																															
BSTPOW	50.000	ORBPOW	100.000																																												
DELTAX	0.228	ALPHAI	5.100																																												
MACH	5.010	ELVBST	0.000																																												
ELVORB	0.000	BETA	0.000																																												
REFERENCE INFORMATION																																															
REFS	23.6890	SQ IN																																													
REFL	4.1930	IN																																													
REFB	6.5000	IN																																													
XMRP	4.9170	IN																																													
YMRP	0.0000	IN																																													
ZMRP	1.3900	IN																																													
SCALE	0.0055																																														

REFERENCE FILE

# AEDC VA 1163 MDAC BOOSTER AND ORBITER TEST DATA AT MACH NUMBER 5

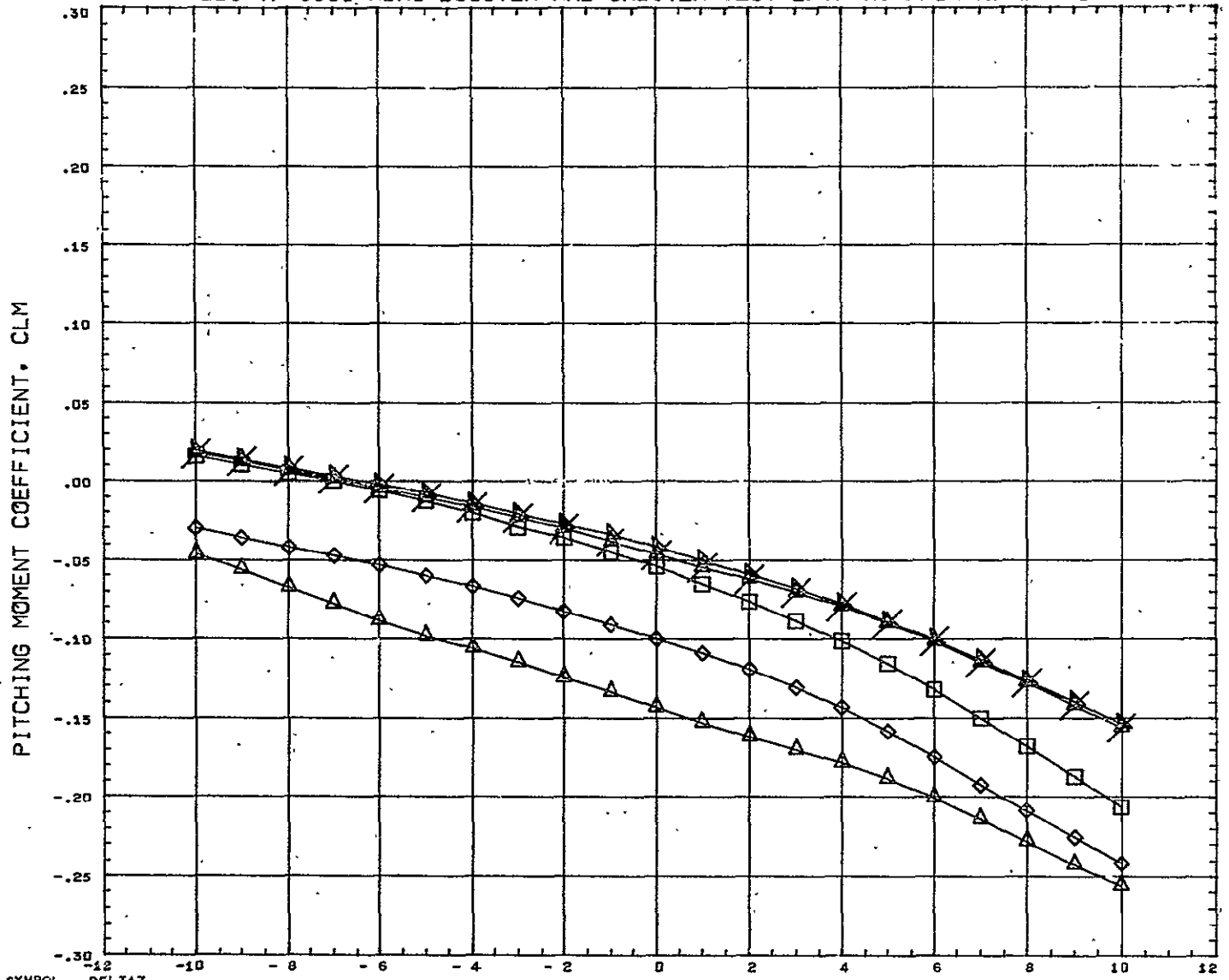

SYMBOL △ ◇ □ × ▽	DELTAZ 0.151 0.182 0.226 0.352 10.000	<b>PARAMETRIC VALUES</b> BSTPOW 50.000 ORBPOW 100.000 DELTAX 0.352 ALPHAI 5.100 MACH 5.010 ELVBST 0.000 ELVORB 0.000 BETA 0.000	<b>REFERENCE INFORMATION</b> REFS 23.6890 SQ IN REFL 4.1930 IN REFB 6.5000 IN XMRP 4.9170 IN YMRP 0.0000 IN ZMRP 1.3900 IN SCALE 0.0055
REFERENCE FILE			

# AEDC VA 1163 MDAC BOOSTER AND ORBITER TEST DATA AT MACH NUMBER 5

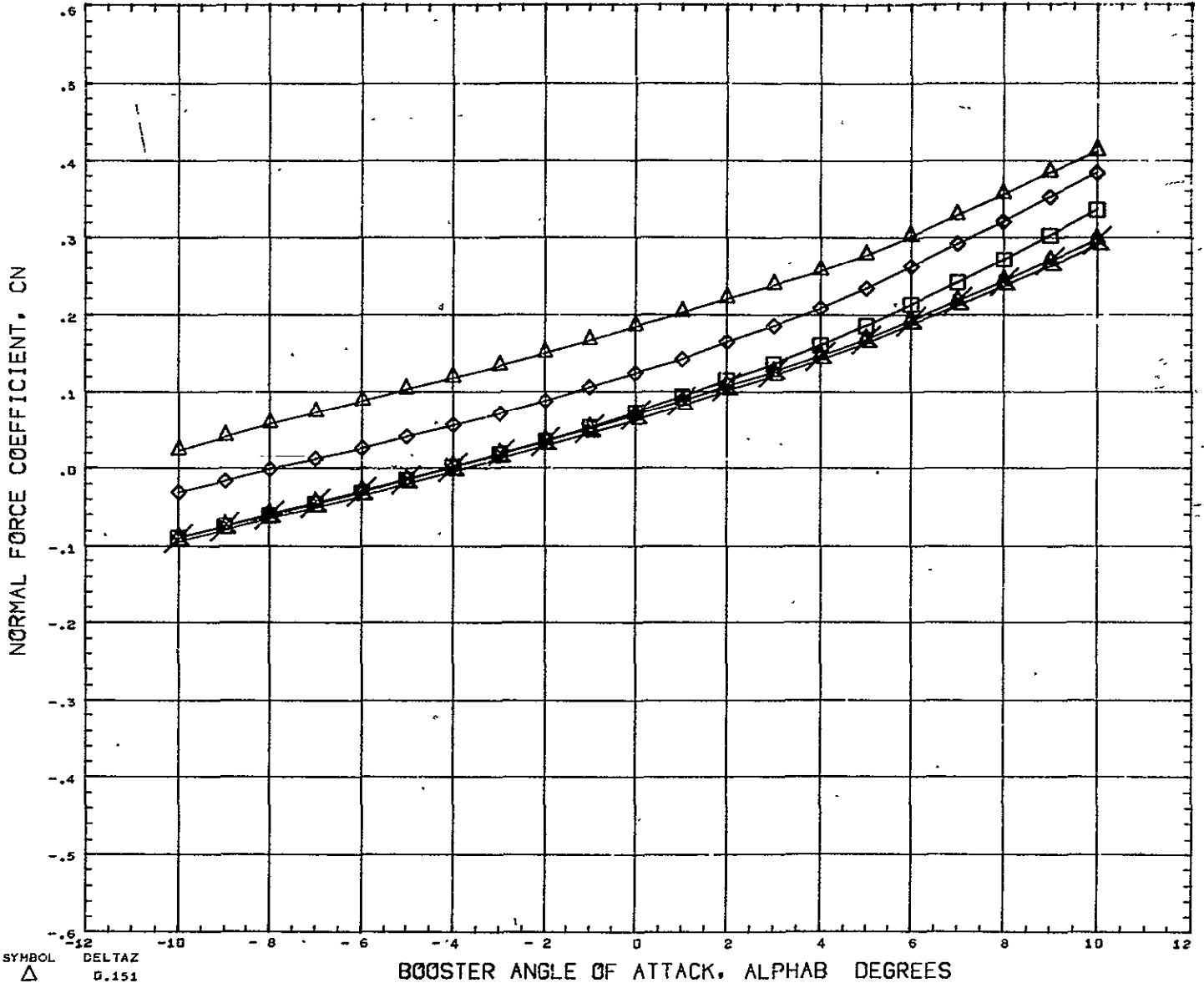

SYMBOL △ ◇ □ × *	DELTAX 0.151 0.182 0.228 0.352 10.000	<table border="0" style="width: 100%;"> <tr> <th colspan="4" style="text-align: left; padding-left: 20px;">PARAMETRIC VALUES</th> </tr> <tr> <td style="padding-right: 10px;">BSTPOW</td> <td style="padding-right: 10px;">50.000</td> <td style="padding-right: 10px;">ORBPOW</td> <td>100.000</td> </tr> <tr> <td>DELTA</td> <td>0.352</td> <td>ALPHA1</td> <td>5.100</td> </tr> <tr> <td>MACH</td> <td>5.010</td> <td>ELVBST</td> <td>0.000</td> </tr> <tr> <td>ELVORB</td> <td>0.000</td> <td>BETA</td> <td>0.000</td> </tr> </table>	PARAMETRIC VALUES				BSTPOW	50.000	ORBPOW	100.000	DELTA	0.352	ALPHA1	5.100	MACH	5.010	ELVBST	0.000	ELVORB	0.000	BETA	0.000	<table border="0" style="width: 100%;"> <tr> <th colspan="3" style="text-align: left;">REFERENCE INFORMATION</th> </tr> <tr> <td>REFS</td> <td>23.6890</td> <td>SQ IN</td> </tr> <tr> <td>REFL</td> <td>4.1930</td> <td>IN</td> </tr> <tr> <td>REFB</td> <td>6.5000</td> <td>IN</td> </tr> <tr> <td>XMRP</td> <td>4.9170</td> <td>IN</td> </tr> <tr> <td>YMRP</td> <td>0.0000</td> <td>IN</td> </tr> <tr> <td>ZMRP</td> <td>1.3900</td> <td>IN</td> </tr> <tr> <td>SCALE</td> <td>0.0056</td> <td></td> </tr> </table>	REFERENCE INFORMATION			REFS	23.6890	SQ IN	REFL	4.1930	IN	REFB	6.5000	IN	XMRP	4.9170	IN	YMRP	0.0000	IN	ZMRP	1.3900	IN	SCALE	0.0056	
PARAMETRIC VALUES																																															
BSTPOW	50.000	ORBPOW	100.000																																												
DELTA	0.352	ALPHA1	5.100																																												
MACH	5.010	ELVBST	0.000																																												
ELVORB	0.000	BETA	0.000																																												
REFERENCE INFORMATION																																															
REFS	23.6890	SQ IN																																													
REFL	4.1930	IN																																													
REFB	6.5000	IN																																													
XMRP	4.9170	IN																																													
YMRP	0.0000	IN																																													
ZMRP	1.3900	IN																																													
SCALE	0.0056																																														

REFERENCE FILE

# AEDC VA 1163 MDAC BOOSTER AND ORBITER TEST DATA AT MACH NUMBER 5

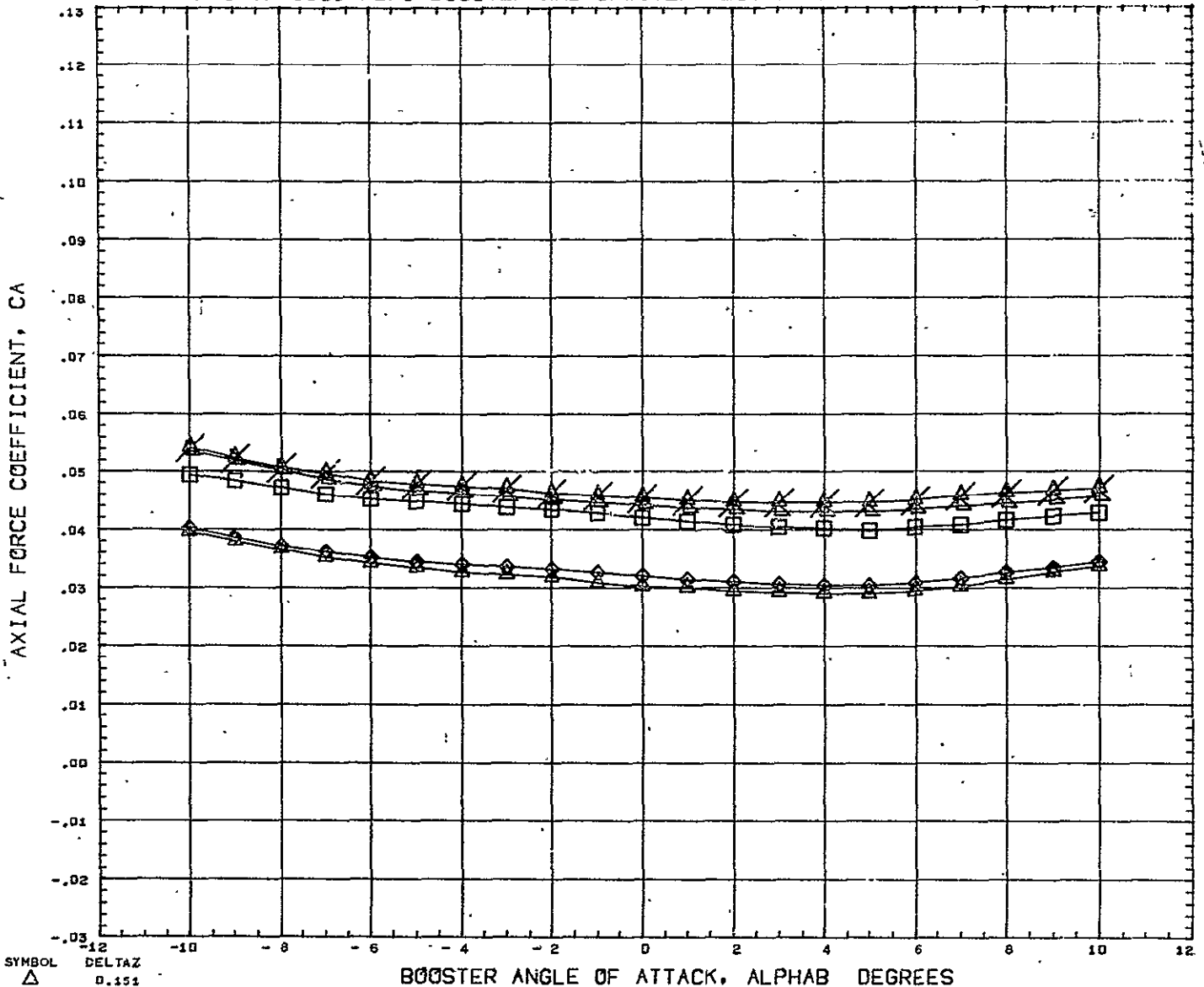

SYMBOL △ ◇ □ ×	DELTA Z 0.151 0.182 0.228 0.352 10.000	PARAMETRIC VALUES BSTPOW 50.000 ORBPOW 100.000 DELTAX 0.352 ALPHA1 5.100 MACH 5.010 ELVBST 0.000 ELVORB 0.000 BETA 0.000	REFERENCE INFORMATION REFS 23.6890 SQ IN REFL 4.1936 IN REFB 6.5000 IN XMRP 4.9170 IN YMRP 0.0000 IN ZMRP 1.3900 IN SCALE 0.0055
----------------------------	---	--	---

REFERENCE FILE

# AEDC VA 1163 MDAC BOOSTER AND ORBITER TEST DATA AT MACH NUMBER 5

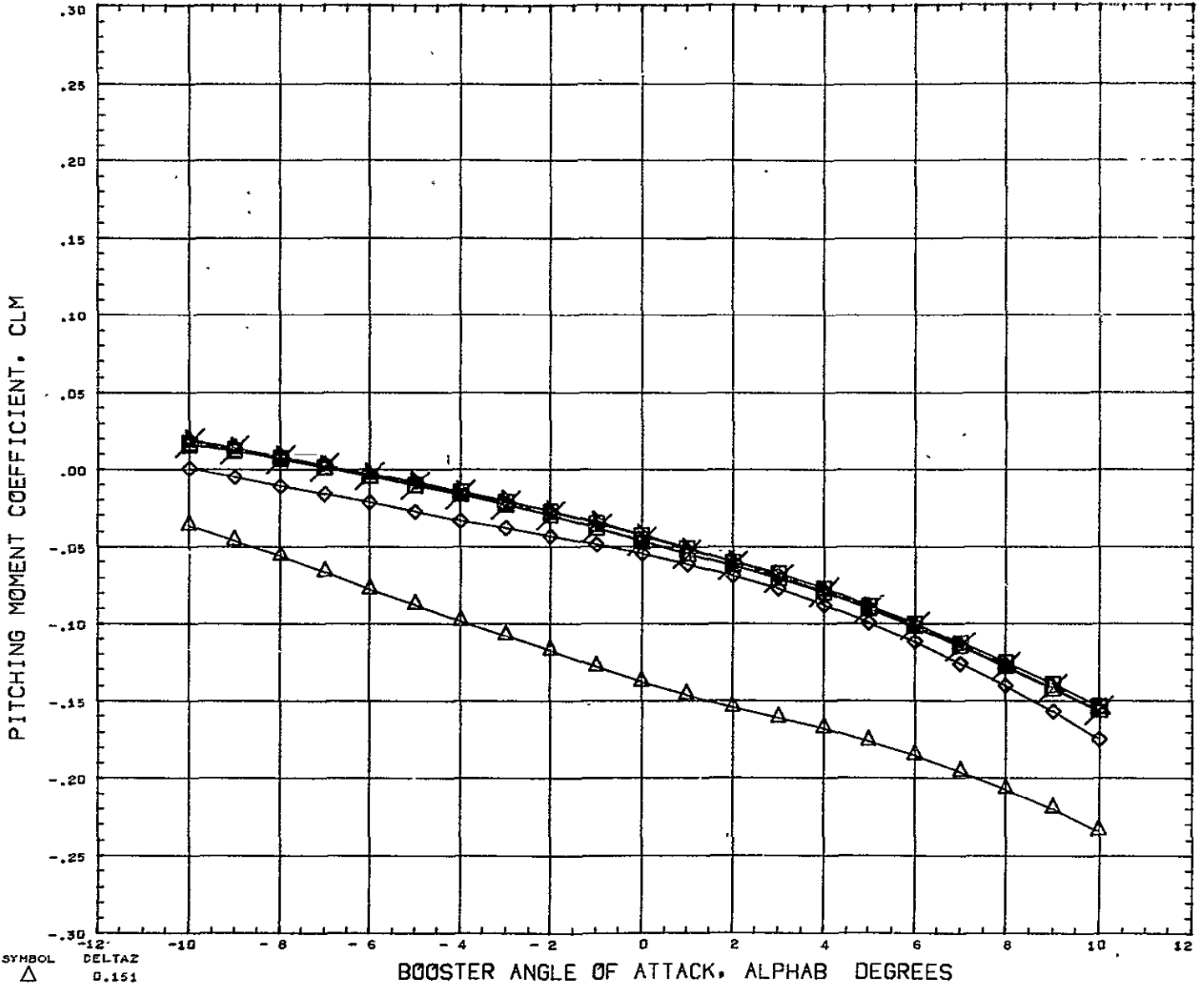

SYMBOL △ ◇ □ ○ ×	DELTAZ 0.151 0.182 0.228 0.352 0.599 10.000	<table border="0" style="width: 100%;"> <tr> <th colspan="4" style="text-align: center;">PARAMETRIC VALUES</th> </tr> <tr> <td>BSTPOW</td><td>50.000</td><td>ORBPOW</td><td>100.000</td> </tr> <tr> <td>DELTA X</td><td>0.522</td><td>ALPHA I</td><td>5.100</td> </tr> <tr> <td>MACH</td><td>5.010</td><td>ELVBST</td><td>0.000</td> </tr> <tr> <td>ELVORB</td><td>0.000</td><td>BETA</td><td>0.000</td> </tr> </table>	PARAMETRIC VALUES				BSTPOW	50.000	ORBPOW	100.000	DELTA X	0.522	ALPHA I	5.100	MACH	5.010	ELVBST	0.000	ELVORB	0.000	BETA	0.000	<table border="0" style="width: 100%;"> <tr> <th colspan="3" style="text-align: center;">REFERENCE INFORMATION</th> </tr> <tr> <td>REFS</td><td>23.6890</td><td>SQ IN</td> </tr> <tr> <td>REFL</td><td>4.1930</td><td>IN</td> </tr> <tr> <td>REFB</td><td>6.5000</td><td>IN</td> </tr> <tr> <td>XNRF</td><td>4.9170</td><td>IN</td> </tr> <tr> <td>YNRF</td><td>0.0000</td><td>IN</td> </tr> <tr> <td>ZNRF</td><td>1.3900</td><td>IN</td> </tr> <tr> <td>SCALE</td><td>0.0055</td><td></td> </tr> </table>	REFERENCE INFORMATION			REFS	23.6890	SQ IN	REFL	4.1930	IN	REFB	6.5000	IN	XNRF	4.9170	IN	YNRF	0.0000	IN	ZNRF	1.3900	IN	SCALE	0.0055	
PARAMETRIC VALUES																																															
BSTPOW	50.000	ORBPOW	100.000																																												
DELTA X	0.522	ALPHA I	5.100																																												
MACH	5.010	ELVBST	0.000																																												
ELVORB	0.000	BETA	0.000																																												
REFERENCE INFORMATION																																															
REFS	23.6890	SQ IN																																													
REFL	4.1930	IN																																													
REFB	6.5000	IN																																													
XNRF	4.9170	IN																																													
YNRF	0.0000	IN																																													
ZNRF	1.3900	IN																																													
SCALE	0.0055																																														

REFERENCE FILE

# AEDC VA 1163 MDAC BOOSTER AND ORBITER TEST DATA AT MACH NUMBER 5

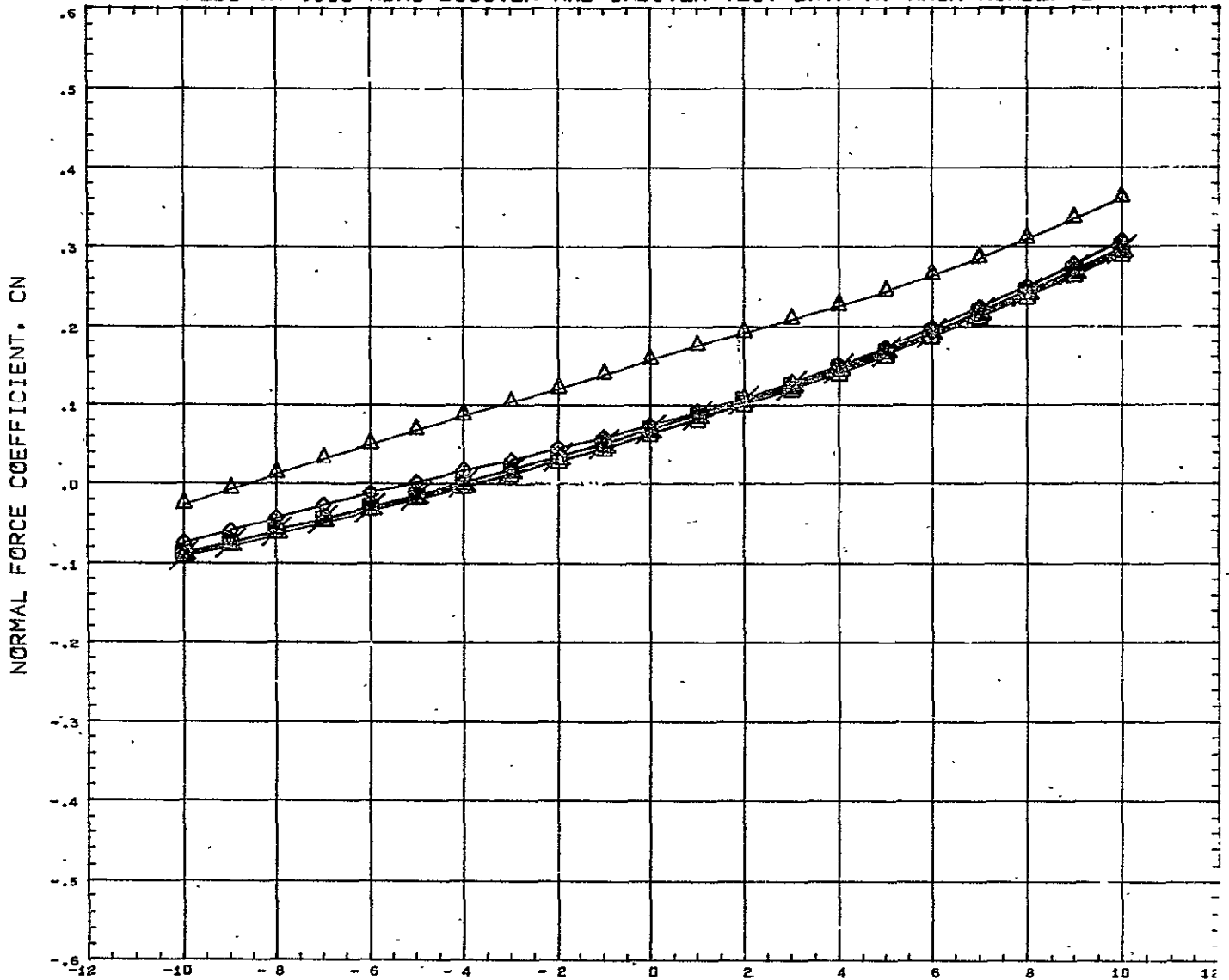

SYMBOL	DELTAZ 0.151 0.182 0.228 0.352 0.599 10.000	PARAMETRIC VALUES BSTPOW 50.000 DELTAZ 0.522 MACH 5.010 ELVORB 0.000	ORBPOW 100.000 ALPHA1 5.100 ELVBST 0.000 BETA 0.000	REFERENCE INFORMATION REFS 23.6890 SQ IN. REFL 4.1930 IN REFB 6.5000 IN XMRF 4.9170 IN YMRF 0.0000 IN ZMRF 1.3930 IN SCALE 0.0055
REFERENCE FILE				

# AEDC VA 1163 MDAC BOOSTER AND ORBITER TEST DATA AT MACH NUMBER 5

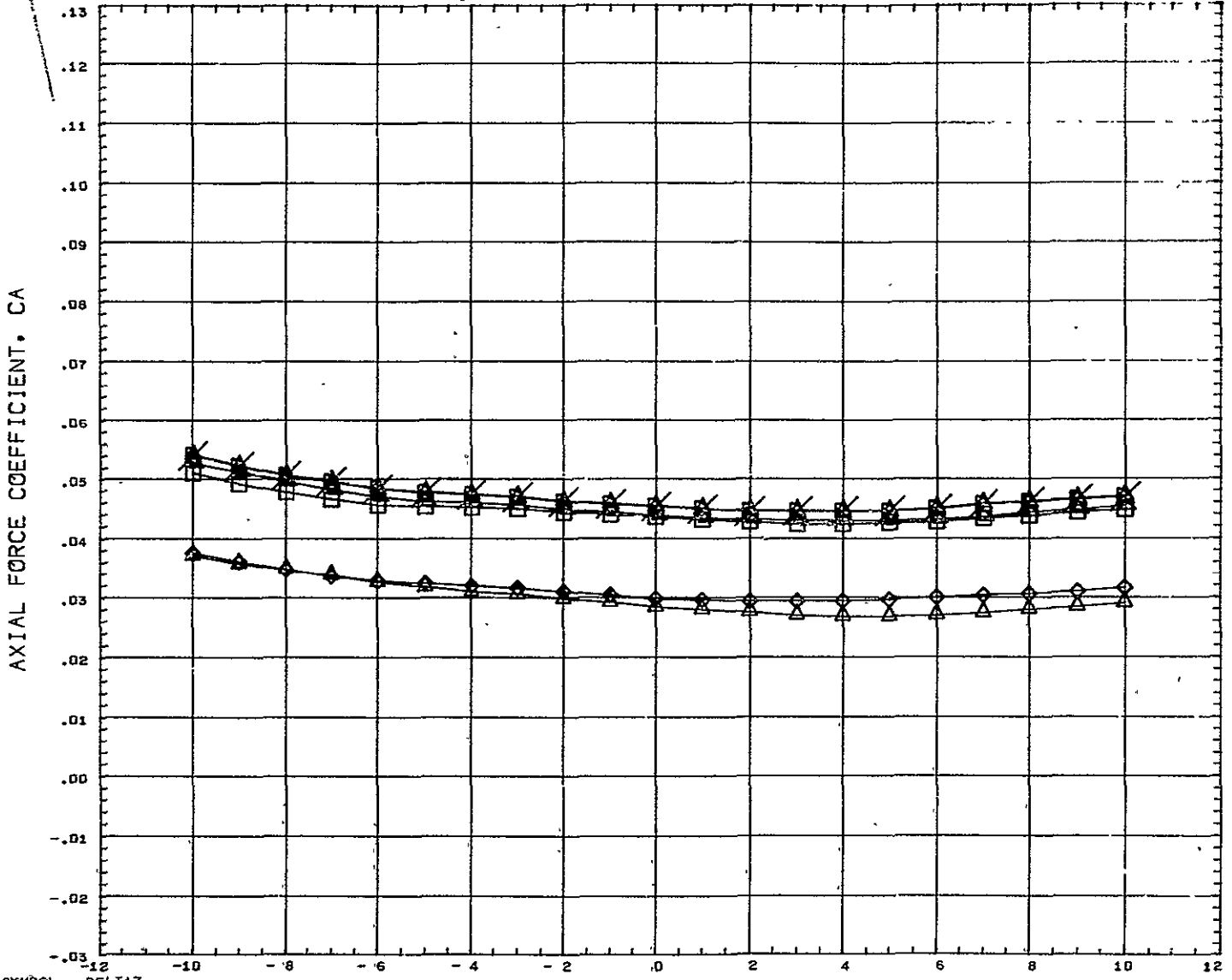

SYMBOL ◻ ◻ ◻ ◻ ◻	DELTAZ 0.151 0.182 0.228 0.352 0.599 10.000	PARAMETRIC VALUES BSTPCW 50.000 DELTAX 0.522 MACH 5.010 ELVORB 0.000 ORBPCW 100.000 ALPHAI 5.100 ELVBST 0.000 BETA 0.070	REFERENCE INFORMATION REFS 23.6890 REFL 4.1930 REFB 6.5000 XMRP 4.9170 YMRP 0.0000 ZMRP 1.3905 SCALE 0.0055	SQ IN IN IN IN IN IN
REFERENCE FILE				



# AEDC VA 1163 MDAC BOOSTER AND ORBITER TEST DATA AT MACH NUMBER 5

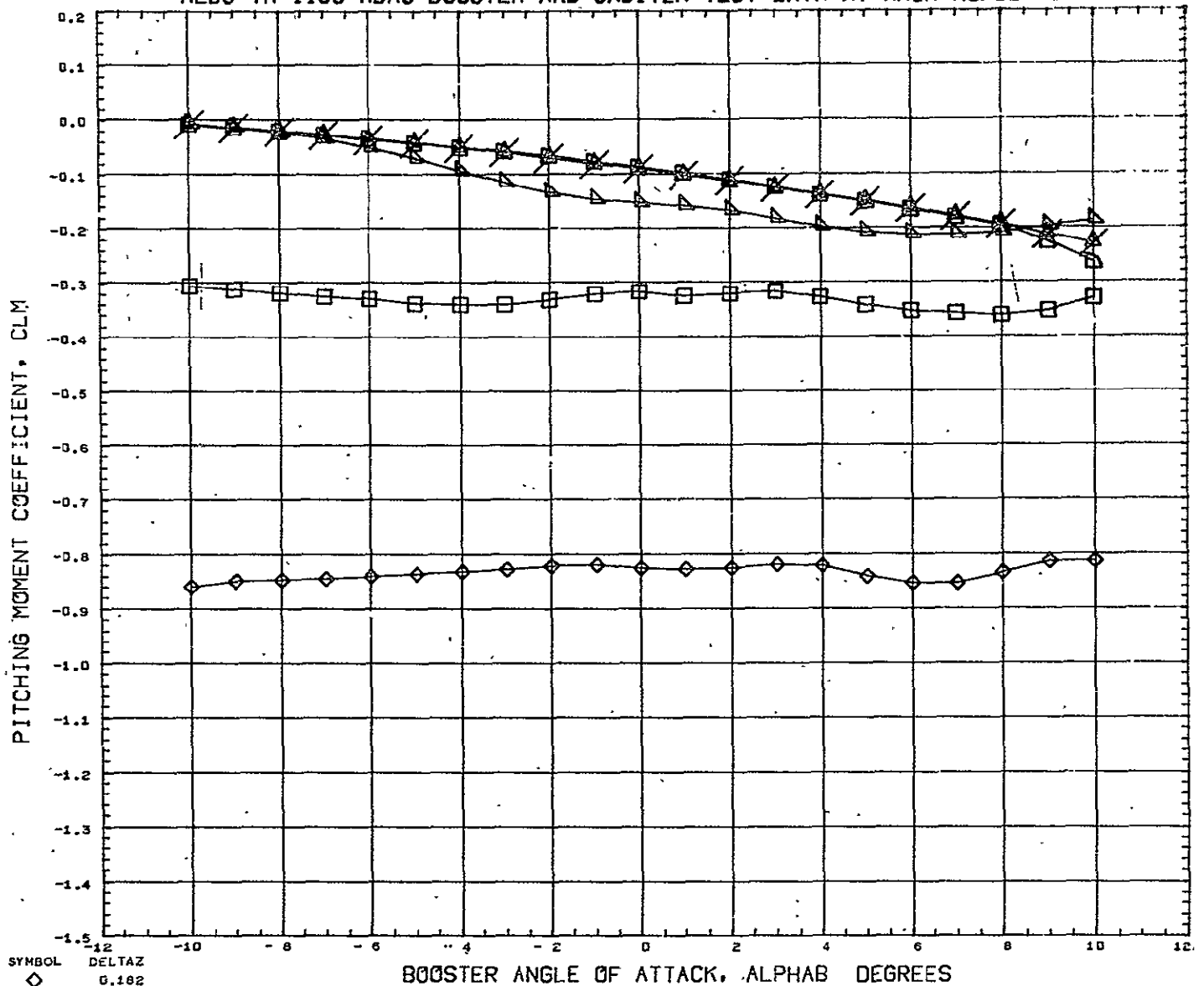

SYMBOL □ △ ◇ ×	DELTAZ 0.182 0.228 0.352 0.599 10.000	PARAMETRIC VALUES BSTPOW - 50.000    ORBPOW    100.000 DELTAX - 0.391    ALPHAI    10.100 MACH    5.010    ELVBST    0.000 ELVORB    0.000    BETA    0.000	REFERENCE INFORMATION REFS    23.6890    50 IN REFL    4.1930    IN REFB    6.5000    IN XMRP    4.9170    IN YMRP    0.0000    IN ZMRP    1.3900    IN SCALE    0.0055
REFERENCE FILE			

# AEDC VA 1163 MDAC BOOSTER AND ORBITER TEST DATA AT MACH NUMBER 5

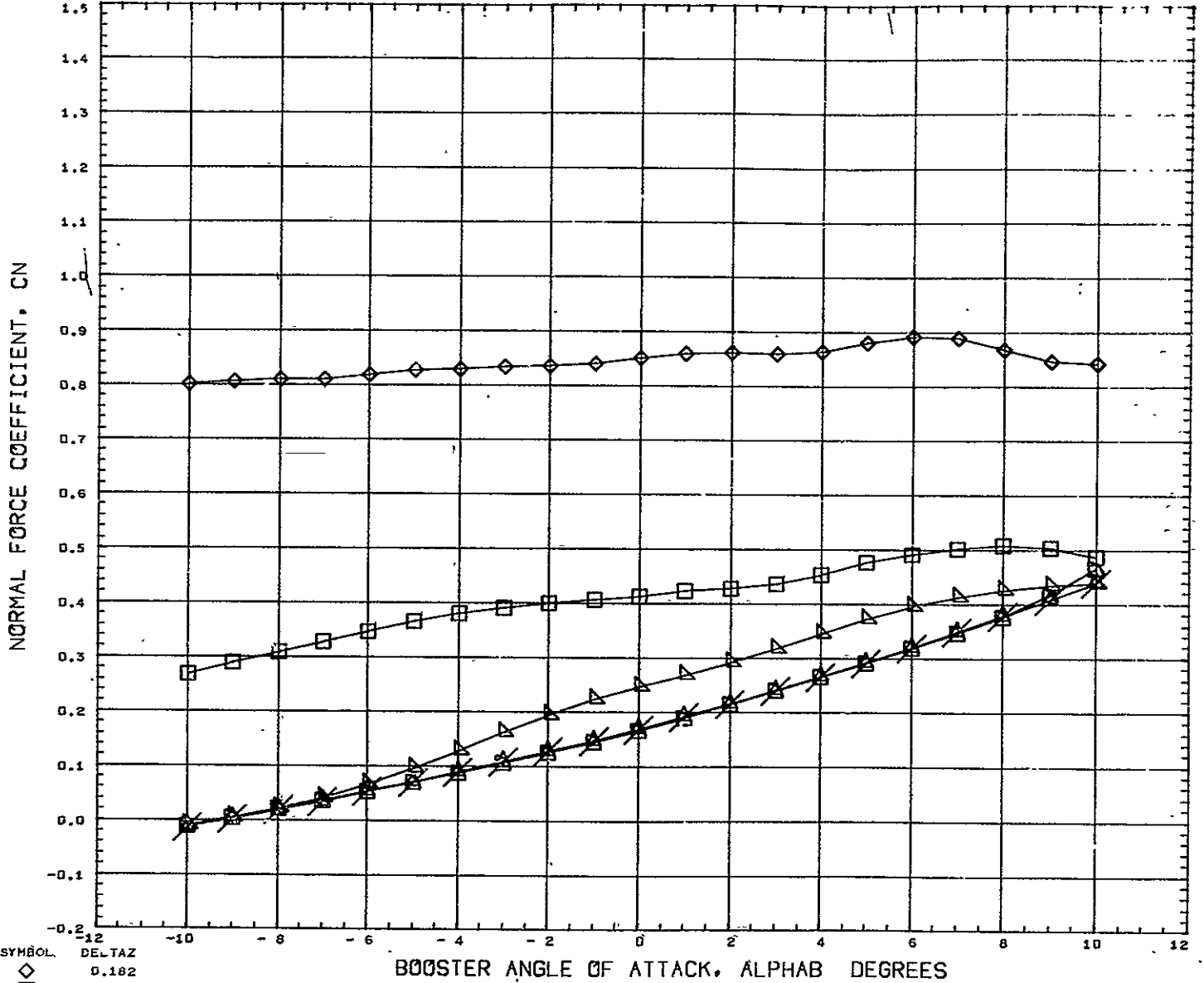

SYMBOL ◇ □ △	DELTA Z 0.182 0.228 0.352 0.599 10.000	PARAMETRIC VALUES BSTPOW 50.000 ORBPOW 100.000 DELTAX - 0.391 ALPHA1 10.100 MACH 5.010 ELVBST 0.000 ELVORB 0.000 BETA 0.000	REFERENCE INFORMATION REFS 23.6890 SQ IN REFL 4.1930 IN REFB 6.5000 IN XMRP 4.9179 IN YMRP 0.0000 IN ZMRP 1.3900 IN SCALE 0.0055
-----------------------	---	---	---

REFERENCE FILE

# AEDC VA 1163 MDAC BOOSTER AND ORBITER TEST DATA AT MACH NUMBER 5

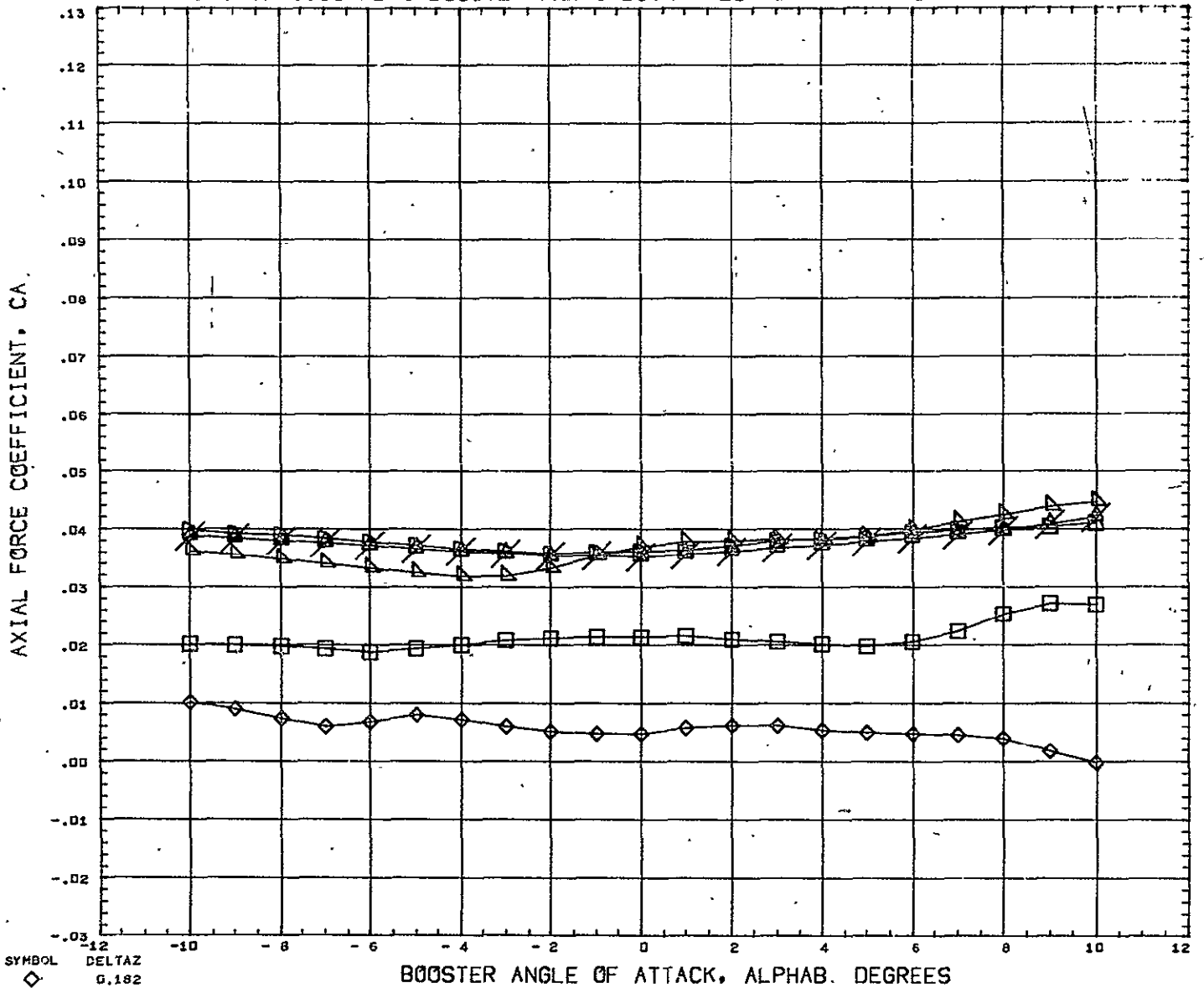

SYMBOL ◇ □ △	DELTAZ 0.182 0.228 0.352 0.599 10.000	PARAMETRIC VALUES BSTPOW 50.000 ORBPOW 100.000 DELTAX - 0.391 ALPHAI 10.100 MACH 5.010 ELVBST 0.000 ELVORB 0.000 BETA 0.030	REFERENCE INFORMATION REFS 23.6890 SQ IN REFL 4.1930 IN REFB 6.5000 IN XMRP 4.9170 IN YMRP 0.0000 IN ZMRP 1.3900 IN SCALE 0.0055
-----------------------	--	---	---

REFERENCE FILE

# AEDC VA 1163 MDAC BOOSTER AND ORBITER TEST DATA AT MACH NUMBER 5

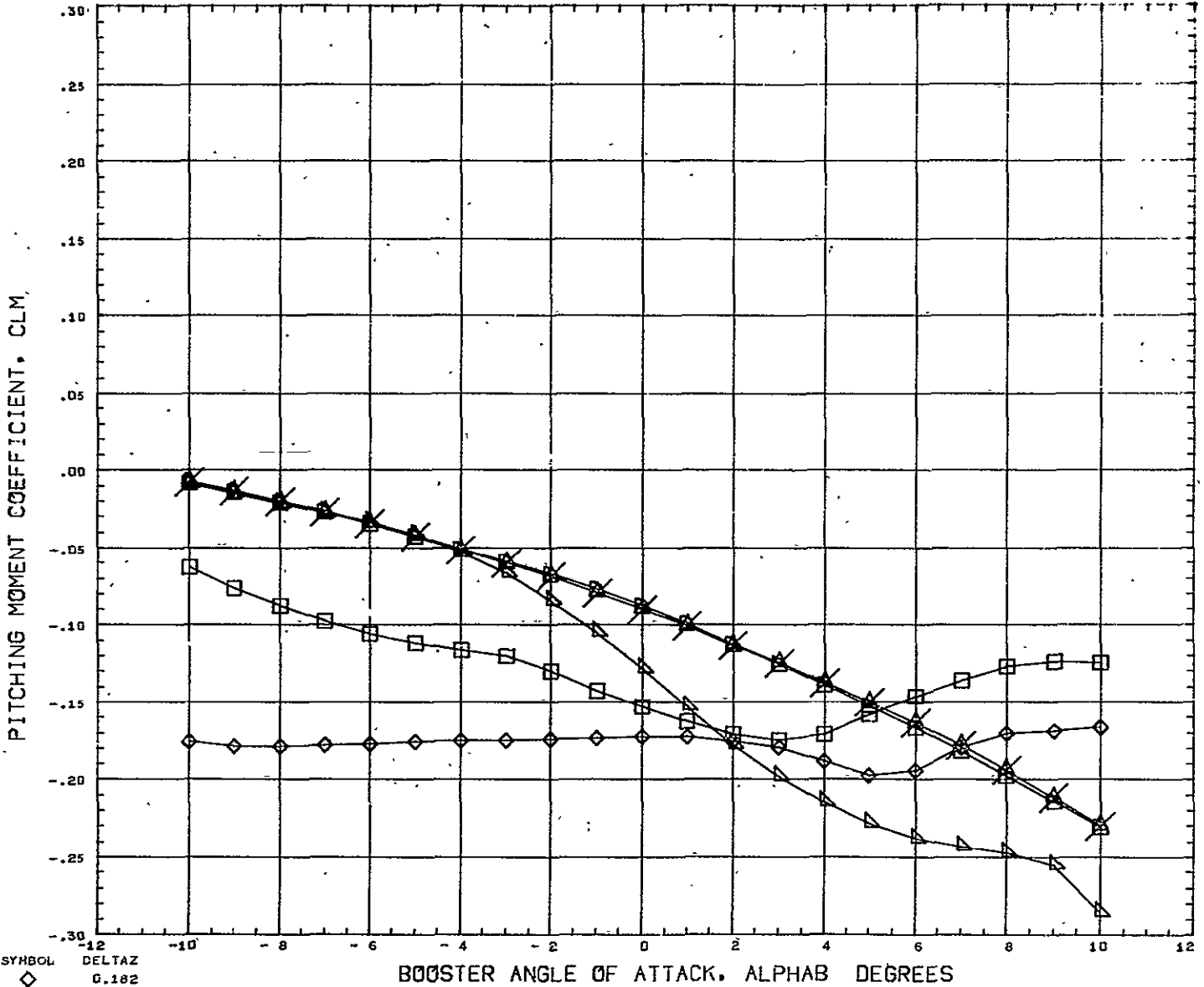

SYMBOL ◻ ◊ △ ×	DELTAX 0.182 0.228 0.352 0.599 10.000	PARAMETRIC VALUES BSTFOW 50.000 ORBFOW 100.000 DELTAX - 0.143 ALPHAI 10.100 MACH 5.010 ELVBST 0.000 ELVORB 0.000 BETA 0.000	REFERENCE INFORMATION REFS 23.6890 SQ IN REFL 4.1930 IN REFB 6.5000 IN XMRP 4.9170 IN YMRP 0.0000 IN ZMRP 1.3900 IN SCALE 0.0055
----------------------------	--	---	---

REFERENCE FILE

# AEDC VA 1163 MDAC BOOSTER AND ORBITER TEST DATA AT MACH NUMBER 5

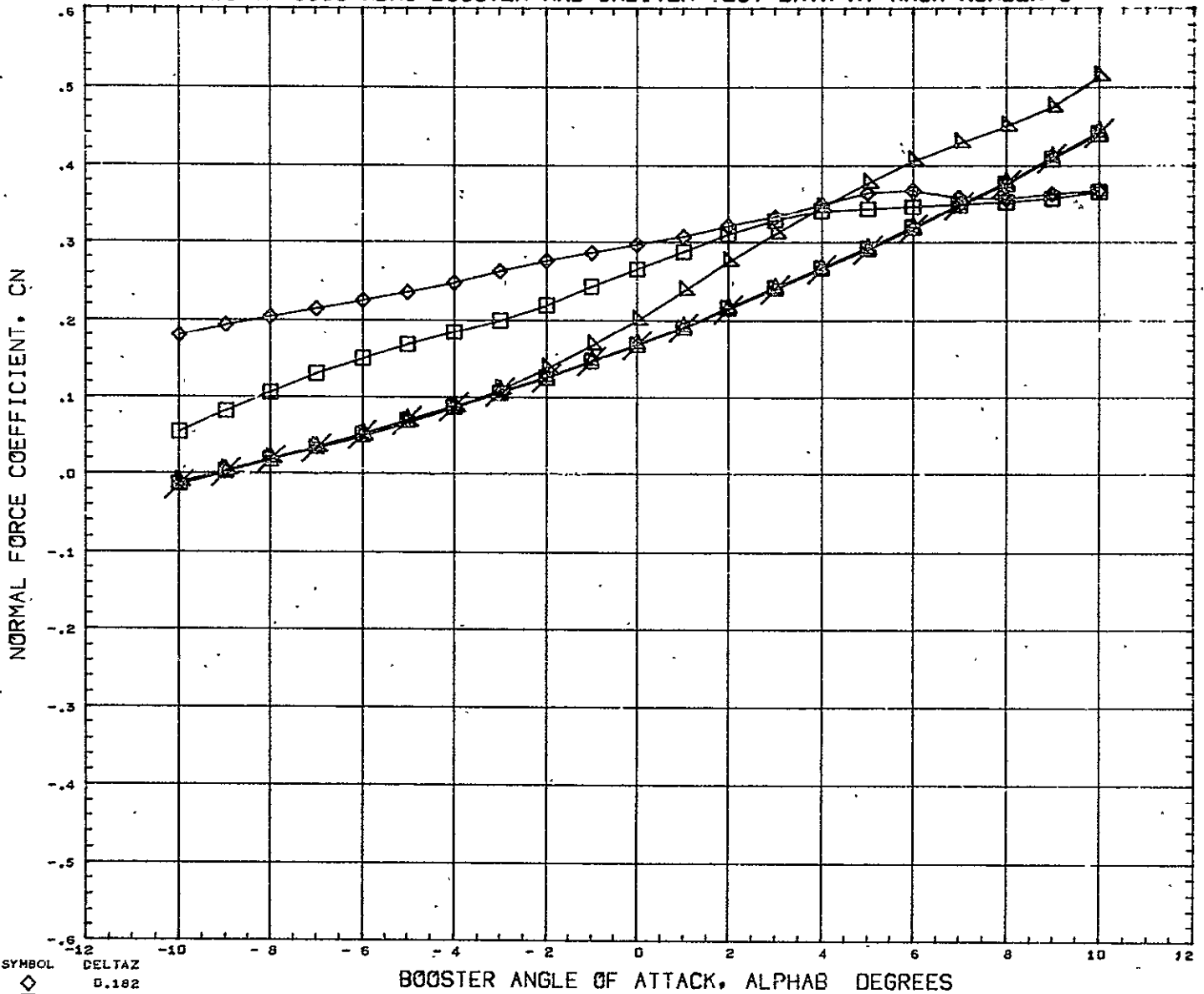

SYMBOL ◇ □ △ ×	DELTAX 0.182 0.228 0.352 0.599 10.000	PARAMETRIC VALUES BSTPOW 50.000 ORBPOW 100.000 DELTAX - 0.143 ALPHAI 10.100 MACH 5.010 ELVBST 0.000 ELVORB 0.000 BETA 0.000	REFERENCE INFORMATION REFS 23.6890 SQ IN REFL 4.1930 IN REFB 6.5000 IN XNRF 4.9170 IN YNRF 0.0000 IN ZNRF 1.3900 IN SCALE 0.0055
----------------------------	--	---	---

REFERENCE FILE

# AEDC VA 1163 MDAC BOOSTER AND ORBITER TEST DATA AT MACH NUMBER 5

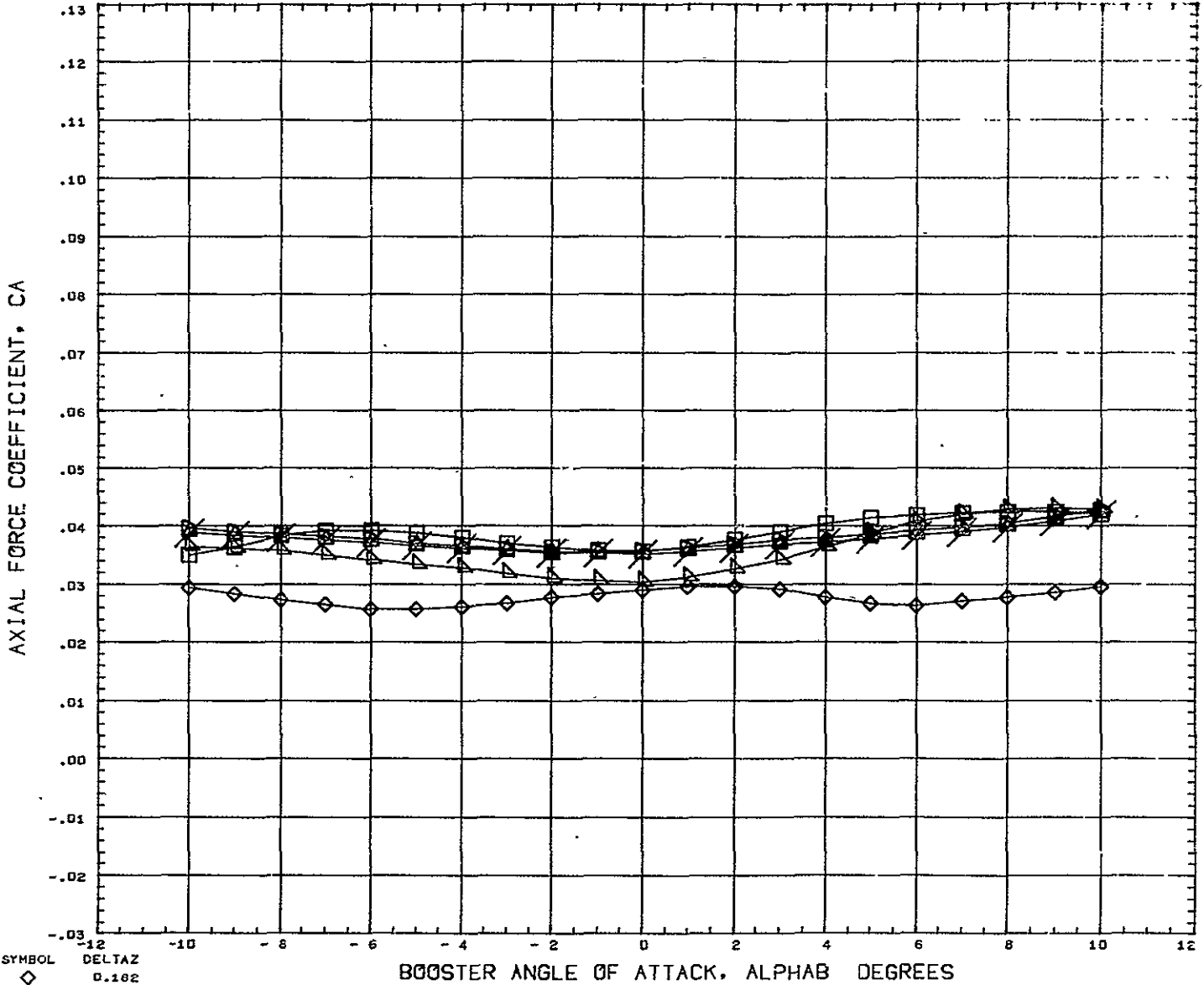

SYMBOL $\diamond$ $\square$ $\triangle$	DELTA Z 0.102 0.228 0.352 0.599 10.000	PARAMETRIC VALUES BSTPOW 50.000 ORBPOW 100.000 JELTAX - 0.143 ALPHAI 10.100 MACH 5.010 ELVBST 0.000 ELVORB 0.000 BETA 0.000	REFERENCE INFORMATION REFS 23.6890 SQ IN REFL 4.1930 IN REFB 6.5000 IN XMRP 4.9170 IN YMRP 0.0000 IN ZMRP 1.3900 IN SCALE 0.0055
--	---	---	---

REFERENCE FILE

# AEDC VA 1163 MDAC BOOSTER AND ORBITER TEST DATA AT MACH NUMBER 5

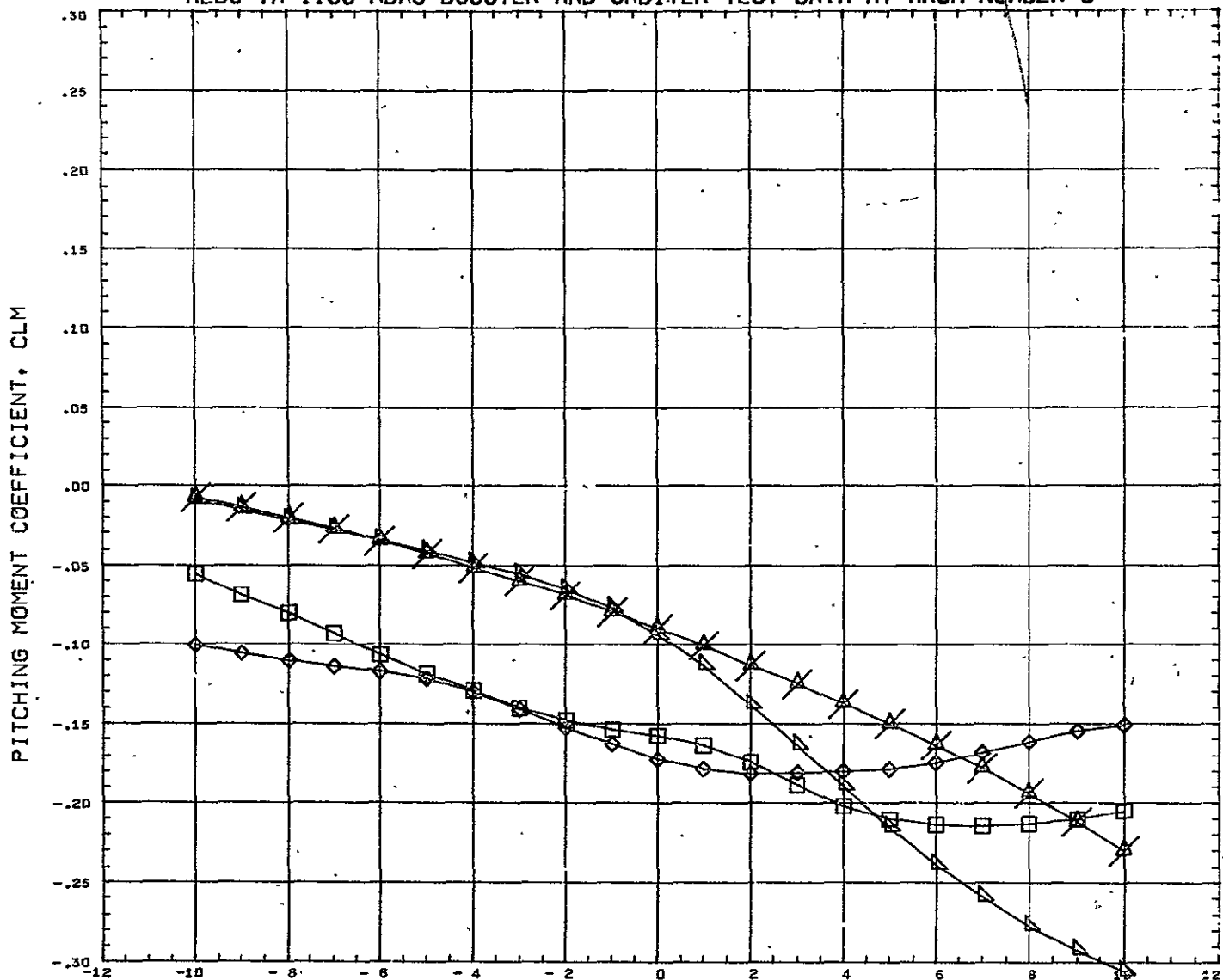

SYMBOL ◊ □ △	DELTAZ 0.182 0.228 0.352 10.000	PARAMETRIC VALUES BSTPOW 50.000 ORBPOW 100.000 DELTAX - 0.019 ALPHA1 10.100 MACH 5.010 ELVBST 0.000 ELVORB 0.000 BETA 0.000	REFERENCE INFORMATION REFS 23.6890 SQ IN REFL 4.1930 IN REFB 6.5000 IN XMRP 4.9170 IN YMRP 0.0000 IN ZMRP 1.3900 IN SCALE 0.0055
-----------------------	---	---	---

REFERENCE FILE

# AEDC VA 1163 MDAC BOOSTER AND ORBITER TEST DATA AT MACH NUMBER 5

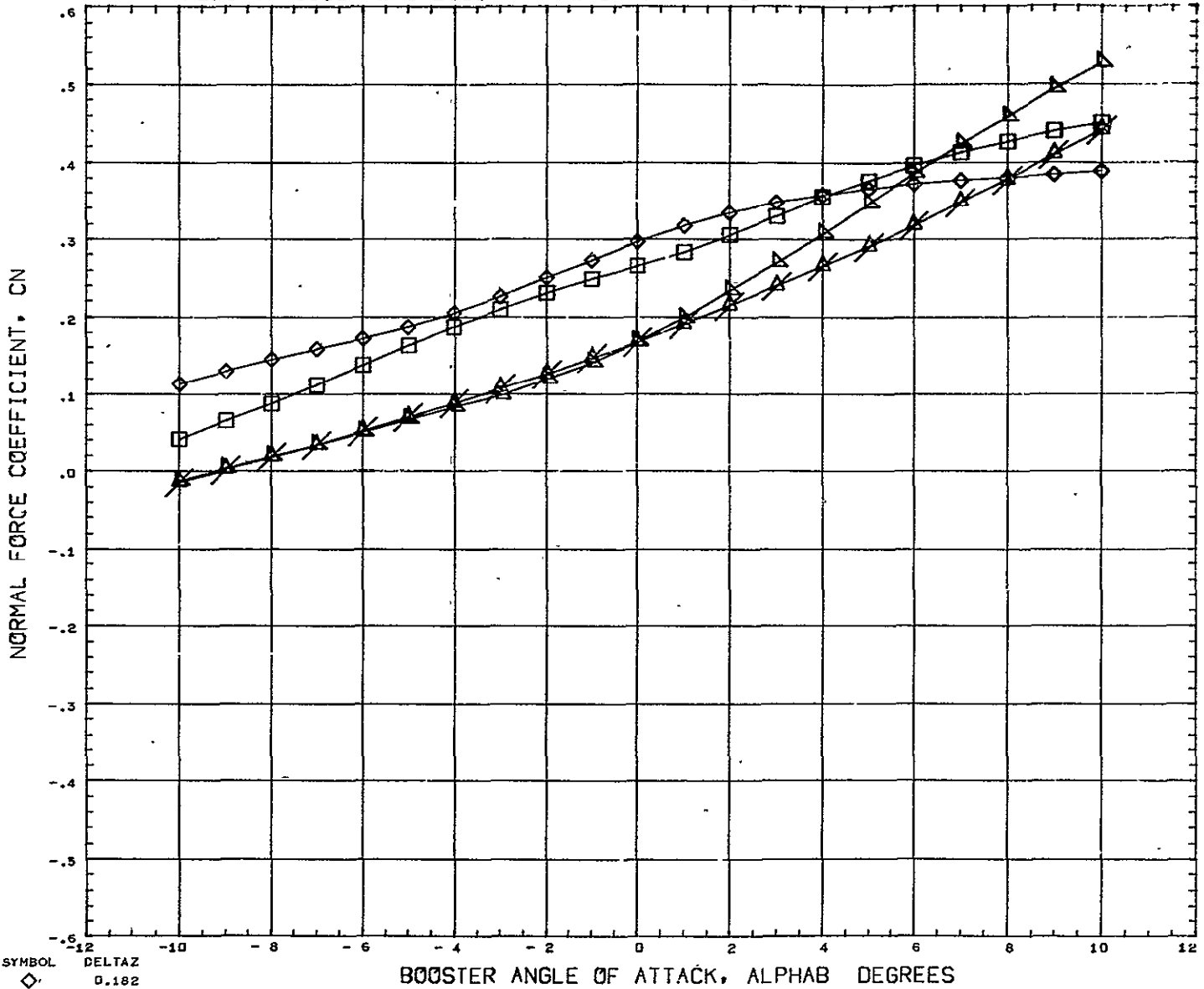

<p>SYMBOL</p> <p>◇</p> <p>□</p> <p>△</p>	<p>DELTAZ</p> <p>0.182</p> <p>0.228</p> <p>0.352</p> <p>10.000</p>	<p>PARAMETRIC VALUES</p> <p>BSTPOW 50.000 ORBPOW 100.000</p> <p>DELTAZ - 0.019 ALPHAI 10.100</p> <p>MACH 5.010 ELVBST 0.000</p> <p>ELVORB 0.000 BETA 0.000</p>	<p>REFERENCE INFORMATION</p> <p>REFS 23.6890 SQ IN</p> <p>REFL 4.1930 IN</p> <p>REFB 6.5000 IN</p> <p>XMRP 4.9170 IN</p> <p>YMRP 0.0000 IN</p> <p>ZMRP 1.3900 IN</p> <p>SCALE 0.0055</p>
<p>REFERENCE FILE</p>			



# AEDC VA 1163 MDAC BOOSTER AND ORBITER TEST DATA AT MACH NUMBER 5

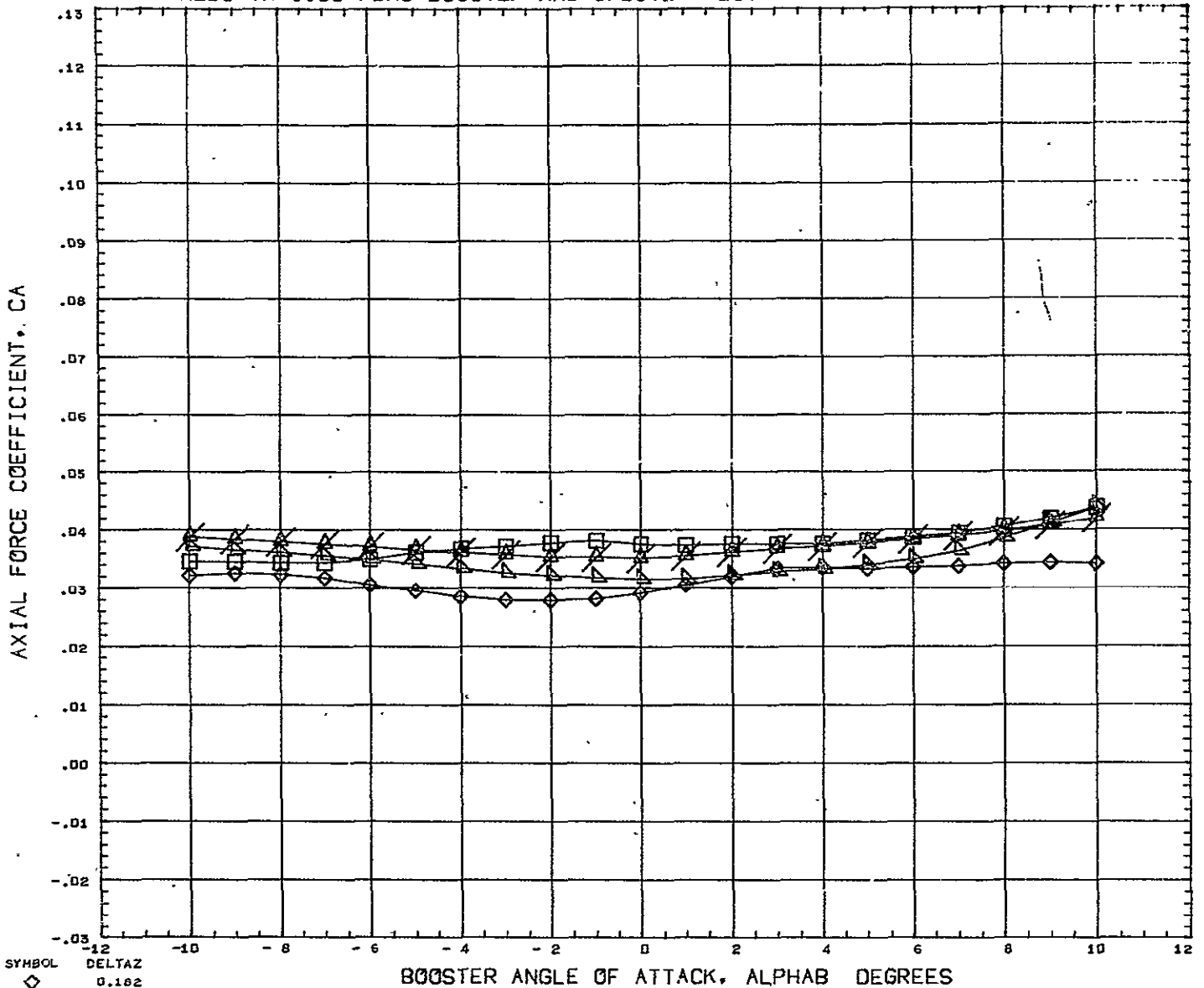

SYMBOL ◇ □ △	DELTAZ 0.162 0.228 0.352 10.000	PARAMETRIC VALUES BSTFOW 50.000 ORBPOW 100.000 DELTAX - 0.019 ALPHAI 10.100 MACH 5.010 ELVBST 0.000 ELVORB 0.000 BETA 0.000	REFERENCE INFORMATION REFS 23.6890 SQ IN REFL 4.1930 IN REFB 6.5000 IN XMRF 4.9170 IN YMRF 0.0000 IN ZMRF 1.3900 IN SCALE 0.0050
-----------------------	---	---	---

REFERENCE FILE

# AEDC VA 1163 MDAC BOOSTER AND ORBITER TEST DATA AT MACH NUMBER 5

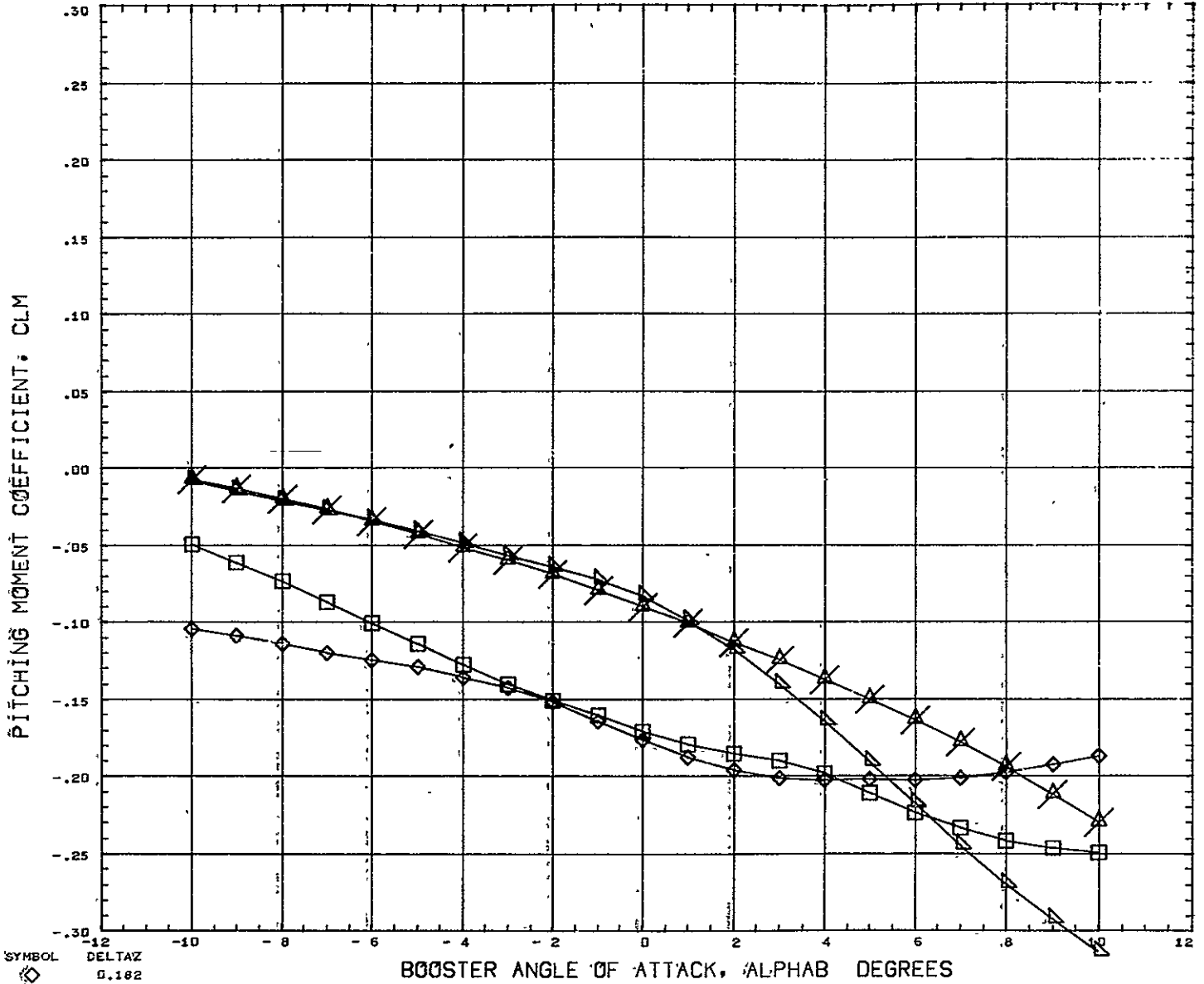

SYMBOL 	DELTAZ 0.182 0.228 0.352 10.000	<b>PARAMETRIC VALUES</b> BSTFOW 50.000 CRBPOW 100.000 DELTAX 0.043 ALPHAI 10.100 MACH 5.010 ELVBST 0.000 ELVORB 0.000 BETA 0.000	<b>REFERENCE INFORMATION</b> REFS 23.6890 SQ IN REFL 4.1930 IN REFB 6.5000 IN XMRF 4.9175 IN YMRP 0.0000 IN ZMRP 1.3900 IN SCALE 0.0055
------------	---	--	--

REFERENCE FILE

# AEDC VA 1163 MDAC BOOSTER AND ORBITER TEST DATA AT MACH NUMBER 5

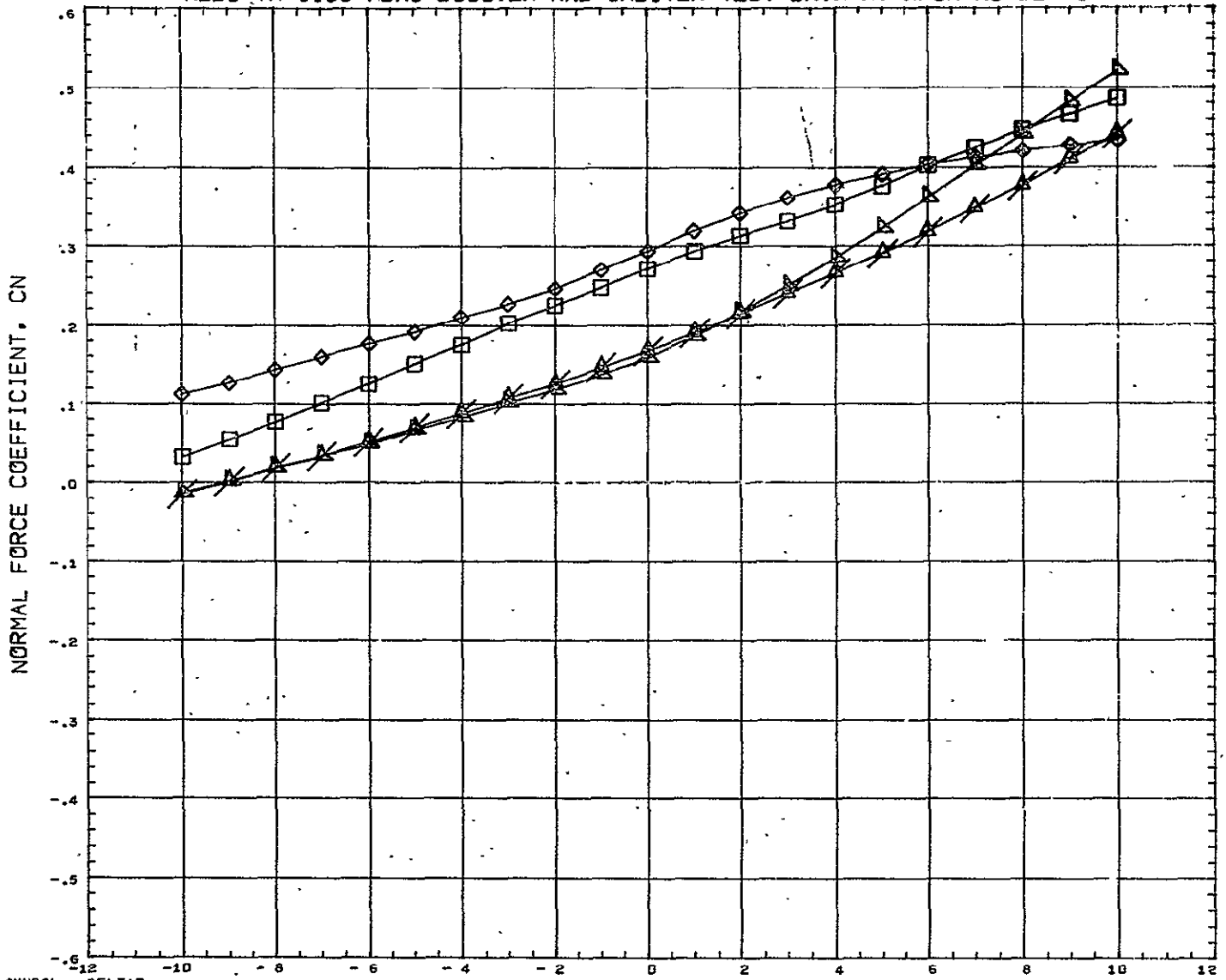

SYMBOL ◇ □ △	DELTAZ 0.182 0.228 0.352 10.000	PARAMETRIC VALUES BSTFOW 50.000 ORBPOW 100.000 DELTAX 0.043 ALPHAI 10.100 MACH 5.010 ELVBST 0.000 ELVORB 0.000 BETA 0.000	REFERENCE INFORMATION REFJ 23.6890 SQ IN REFL 4.1930 IN REFB 6.5000 IN XMRP 4.9170 IN YMRP 0.0000 IN ZMRP 1.3900 IN SCALE 0.0055
REFERENCE FILE			

# AEDC VA 1163 MDAC BOOSTER AND ORBITER TEST DATA AT MACH NUMBER 5

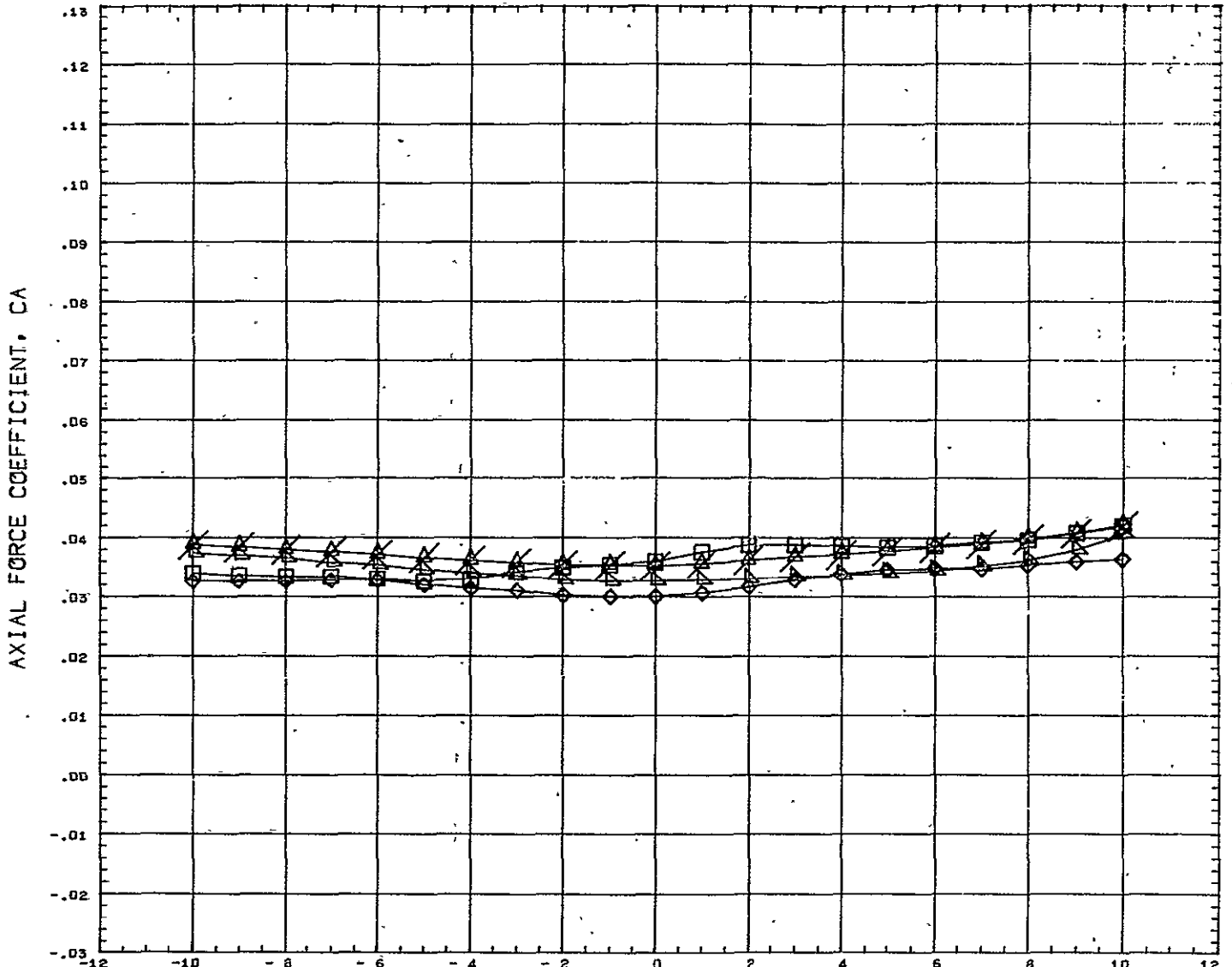

SYMBOL	DELTA Z	PARAMETRIC VALUES				REFERENCE INFORMATION		
◇	0.182	BSTPOW	50.000	ORBPOW	100.000	REFS	23.6890	SQ IN
□	0.228	DELTA X	0.043	ALPHA I	10.100	REFL	4.1930	IN
△	10.000	MACH	5.010	ELVBST	0.000	REFB	6.5000	IN
×		ELVORB	0.000	BETA	0.000	XMRP	4.9170	IN
						YNRT	0.0000	IN
						ZMRP	1.3900	IN
						SCALE	0.0055	

REFERENCE FILE

# AEDC VA 1163 MDAC BOOSTER AND ORBITER TEST DATA AT MACH NUMBER 5

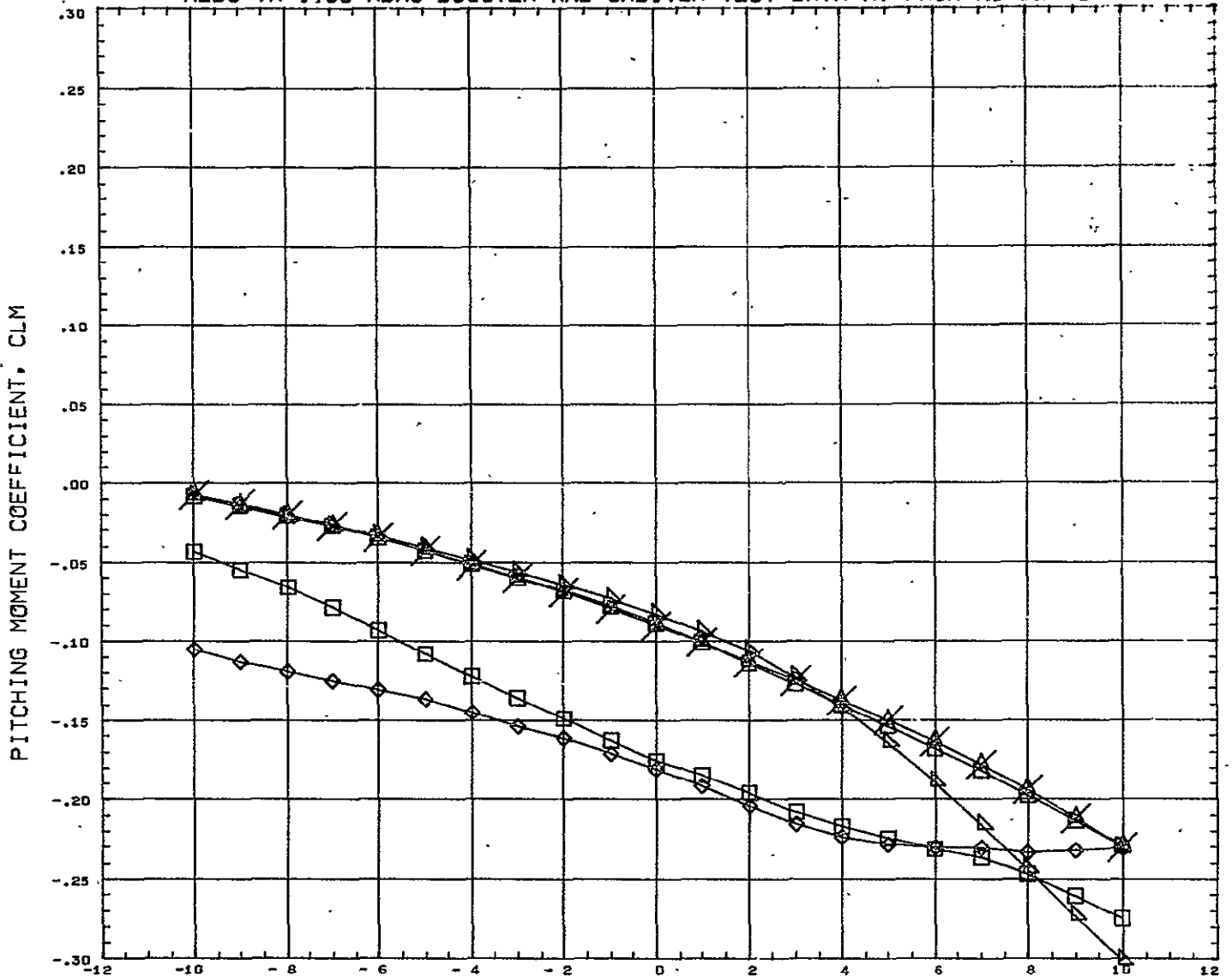

<p>SYMBOL</p> <p>◇</p> <p>□</p> <p>△</p> <p>×</p>	<p>DELTA Z</p> <p>0.182</p> <p>0.228</p> <p>0.352</p> <p>0.599</p> <p>10.000</p>	<p>PARAMETRIC VALUES</p> <p>BSTPCW 50.000 ORBPCW 100.000</p> <p>DELTA X 0.105 ALPHA I 10.100</p> <p>MACH 5.010 ELVBST 0.000</p> <p>ELVORB 0.000 BETA 0.000</p>	<p>REFERENCE INFORMATION</p> <p>REFS 23.6890 SQ IN</p> <p>REFL 4.1930 IN</p> <p>REFB 6.5000 IN</p> <p>XMRP 4.9170 IN</p> <p>YMRP 0.0000 IN</p> <p>ZMRP 1.3900 IN</p> <p>SCALE 0.0055</p>
---	--	--	--

REFERENCE FILE

# AEDC VA 1163 MDAC BOOSTER AND ORBITER TEST DATA AT MACH NUMBER 5

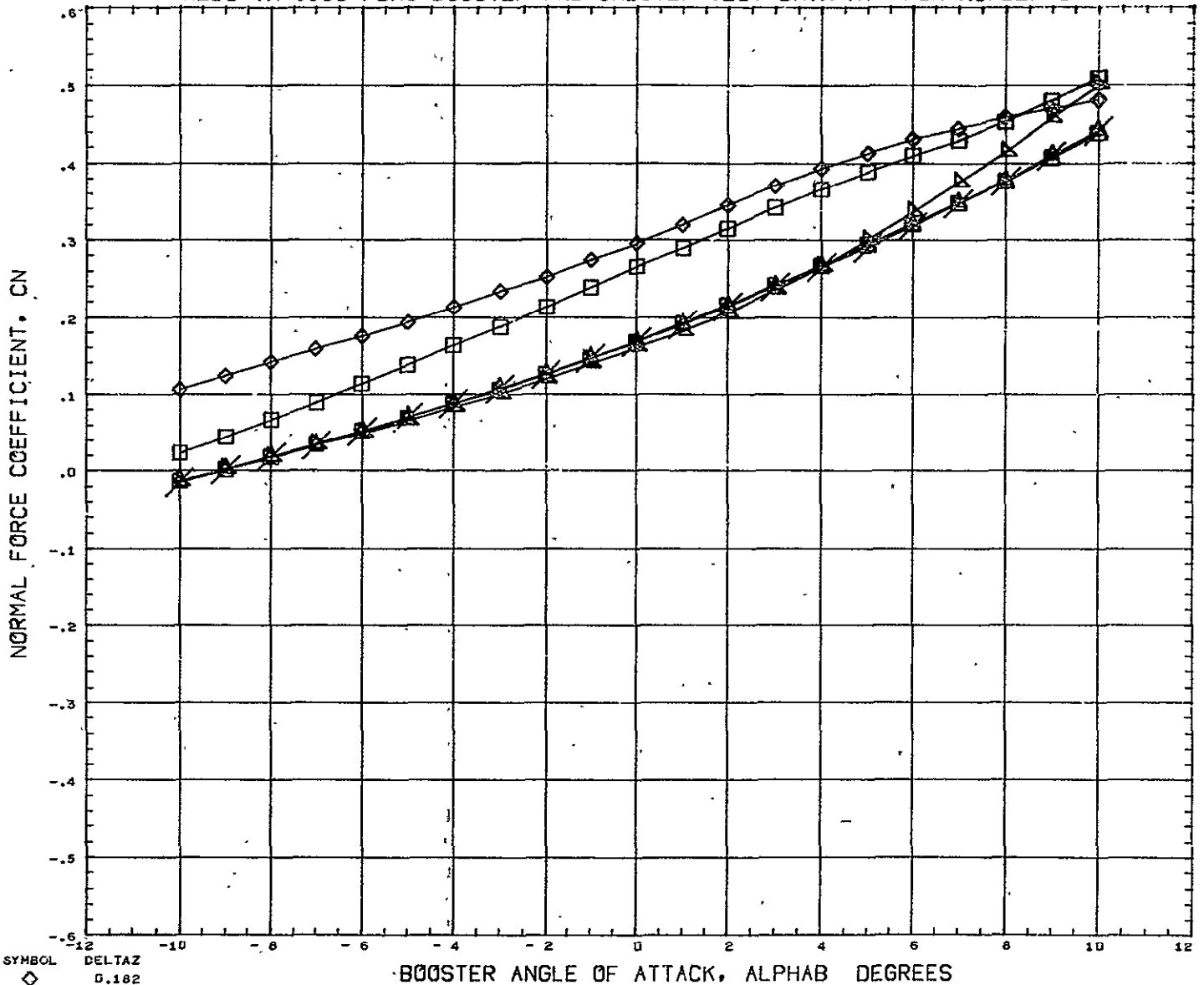

SYMBOL ◇ □ △ ×	DELTAX 0.182 0.228 0.352 0.599 10.000	PARAMETRIC VALUES BSTPOW 50.000 ORBPOW 100.000 DELTAX 0.105 ALPHAI 10.100 MACH 5.010 ELVBST 0.000 ELVORB 0.000 BETA 0.000	REFERENCE INFORMATION REFS 23.6890 SQ IN REFL 4.1930 IN REFB 6.5000 IN XNRF 4.2170 IN YNRF 0.0000 IN ZNRF 1.3900 IN SCALE 0.0055
----------------------------	--	---	---

REFERENCE FILE

# AEDC VA 1163 MDAC BOOSTER AND ORBITER TEST DATA AT MACH NUMBER 5

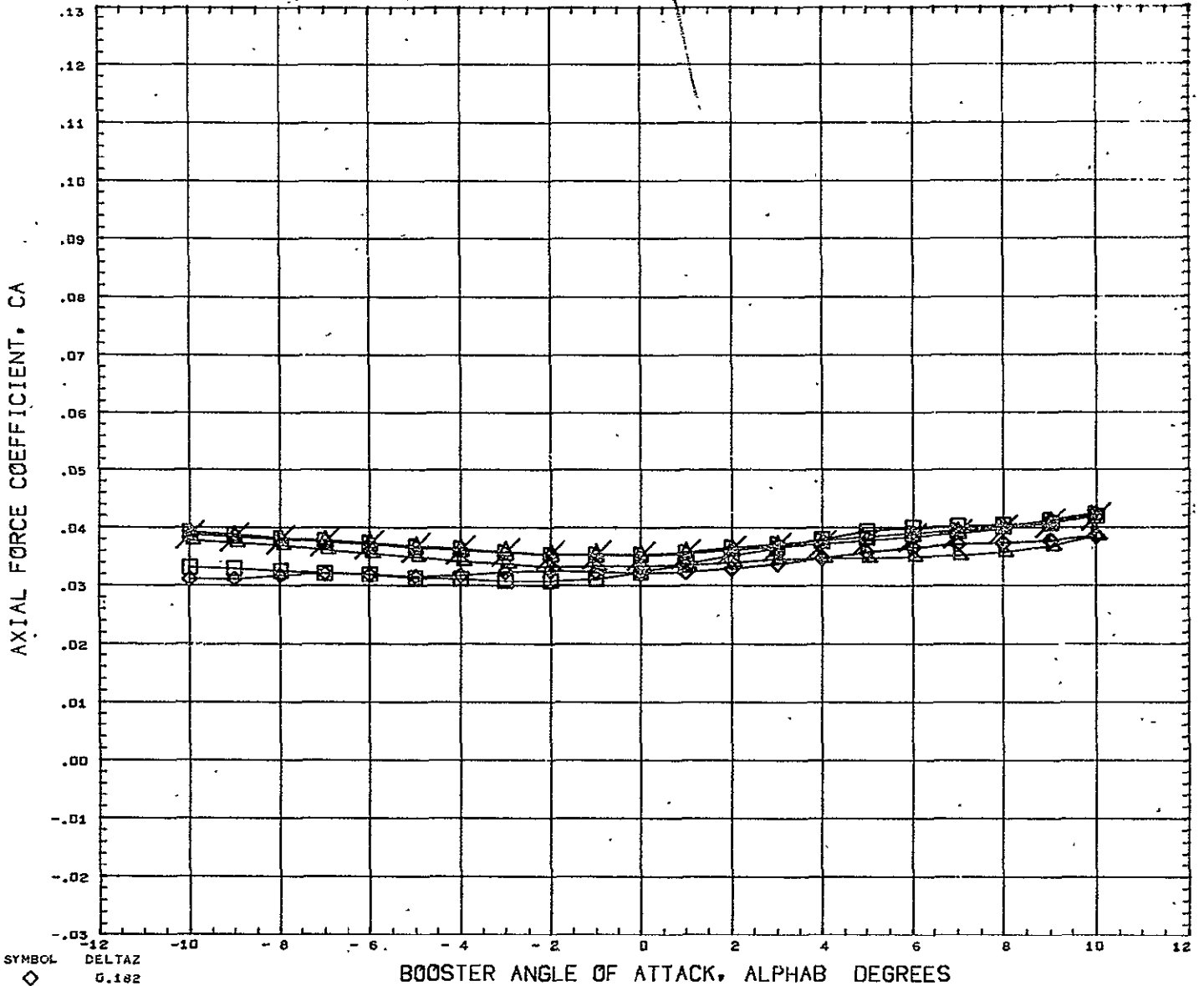

SYMBOL □ □ □ □ □	DELTAX 0.182 0.228 0.352 0.599 10.000	PARAMETRIC VALUES BSTPOW 50.000 ORBPOW 100.000 DELTAX 0.105 ALPHAI 10.100 MACH 5.010 ELVBST 0.000 ELVORB 0.000 BETA 0.600	REFERENCE INFORMATION REFS 23.6890 SQ IN REFL 4.1930 IN REFB 6.5000 IN XHRF 4.9170 IN YHRF 0.0000 IN ZHRF 1.3900 IN SCALE 0.0055
---------------------------------	--	---	---

REFERENCE FILE

# AEDC VA 1163 MDAC BOOSTER AND ORBITER TEST DATA AT MACH NUMBER 5

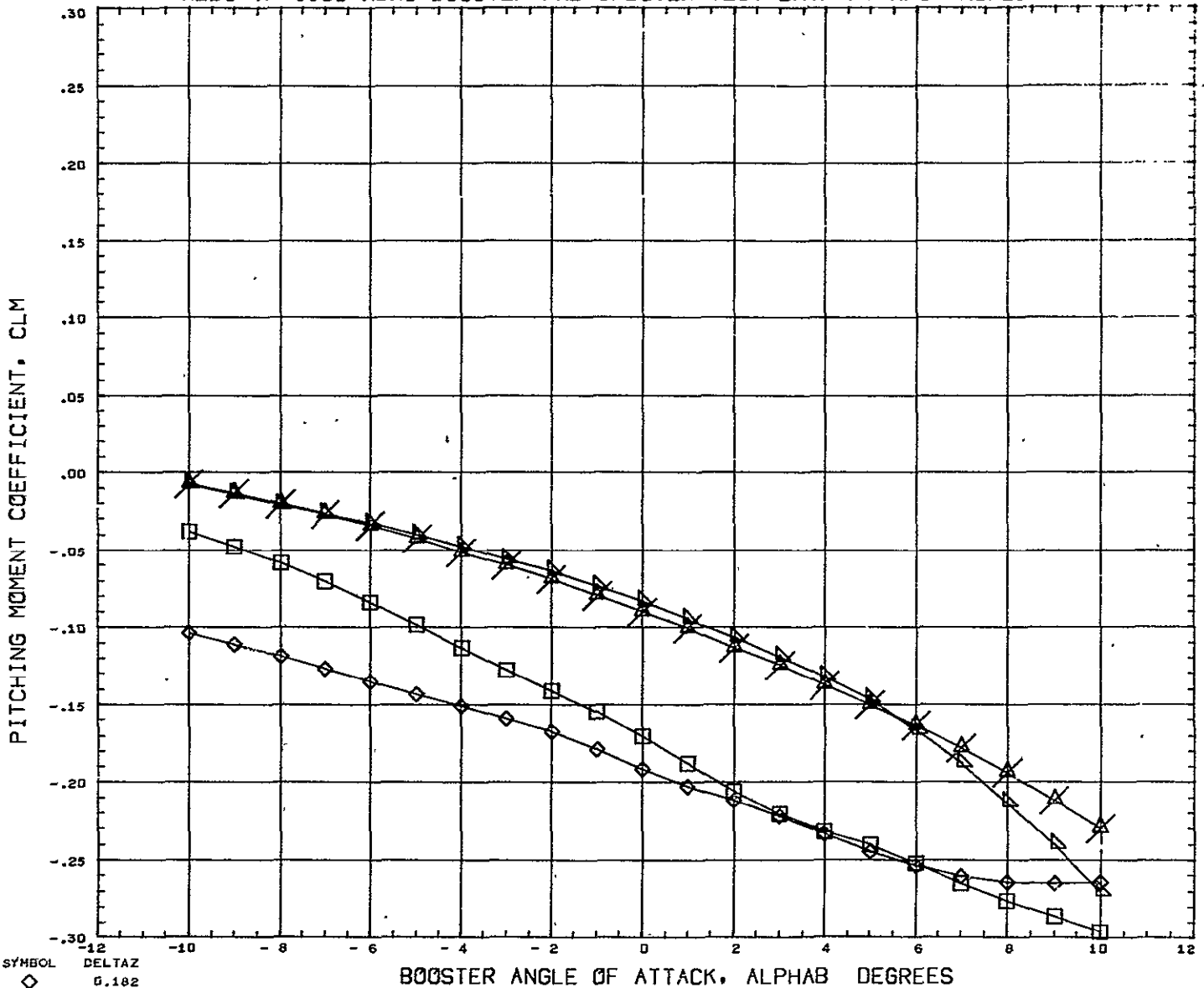

SYMBOL ◇ □ △	DELTAZ 0.182 0.228 0.352 10.000	PARAMETRIC VALUES RSTPOW 50.000 ORBPOW 100.000 DELTAX 0.166 ALPHAI 10.100 MACH 5.010 ELVBST 0.000 ELVORB 0.000 BETA 0.000	REFERENCE INFORMATION REFS 23.6890 SQ IN REFL 4.1930 IN REFB 6.5000 IN XMRP 4.9170 IN YMRP 0.0000 IN ZMRP 1.3900 IN SCALE 0.0055
-----------------------	---	---	---

REFERENCE FILE



# AEDC VA 1163 MDAC BOOSTER AND ORBITER TEST DATA AT MACH NUMBER 5

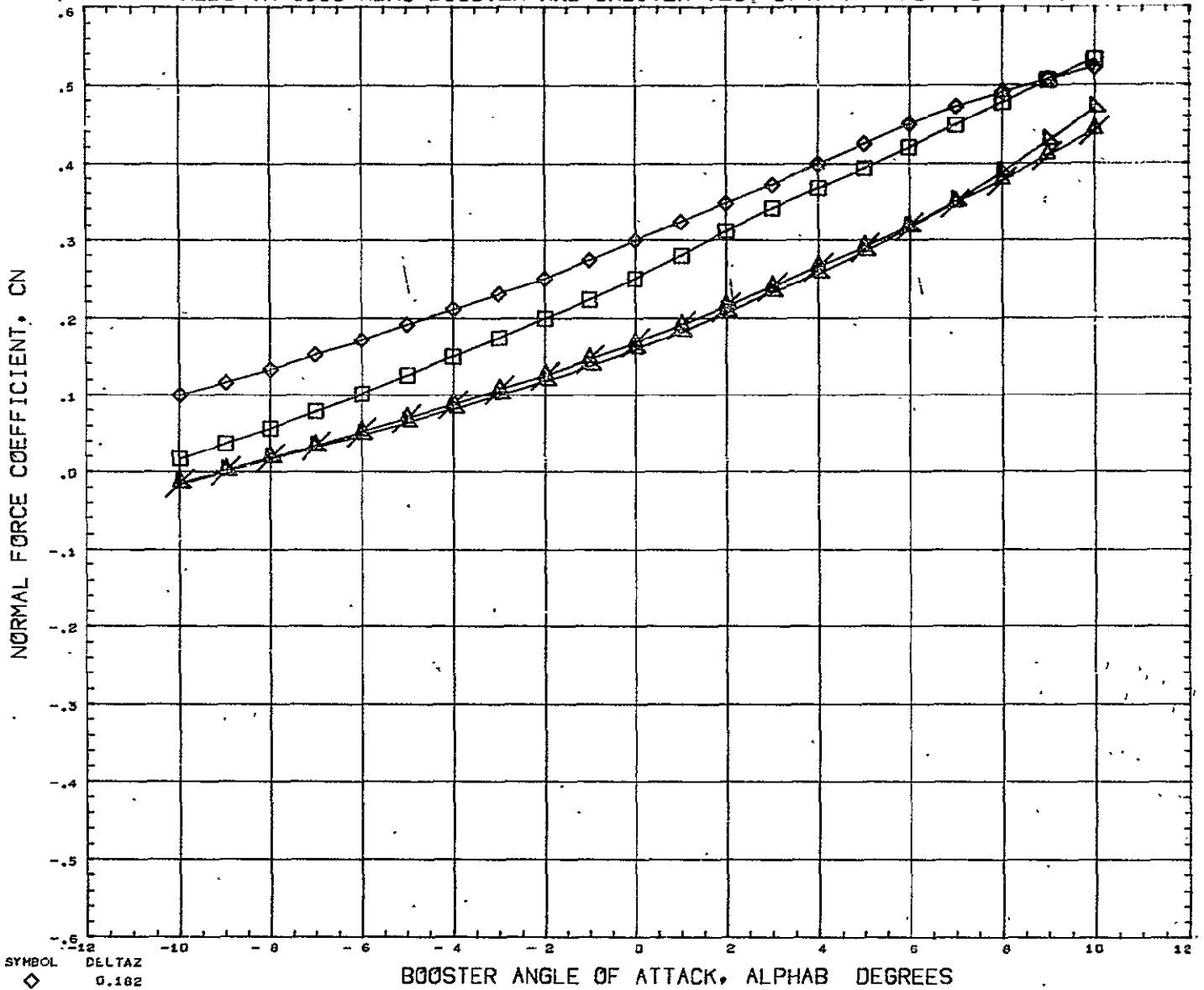

SYMBOL ◇ □ △	DELTAZ 0.182 0.228 0.352 10.000	PARAMETRIC VALUES BSTPOW 50.000 ORBPOW 100.000 DELTAX 0.166 ALPHAI 10.100 MACH 5.010 ELVBST 0.000 ELVORB 0.000 BETA 0.000	REFERENCE INFORMATION REFS 23.6890 SQ IN REFL 4.1930 IN RCFB 6.5000 IN XMRP 4.9170 IN YMRP 0.0000 IN ZMRP 1.3900 IN SCALE 0.0055
REFERENCE FILE			

# AEDC VA 1163 MDAC BOOSTER AND ORBITER TEST DATA AT MACH NUMBER 5

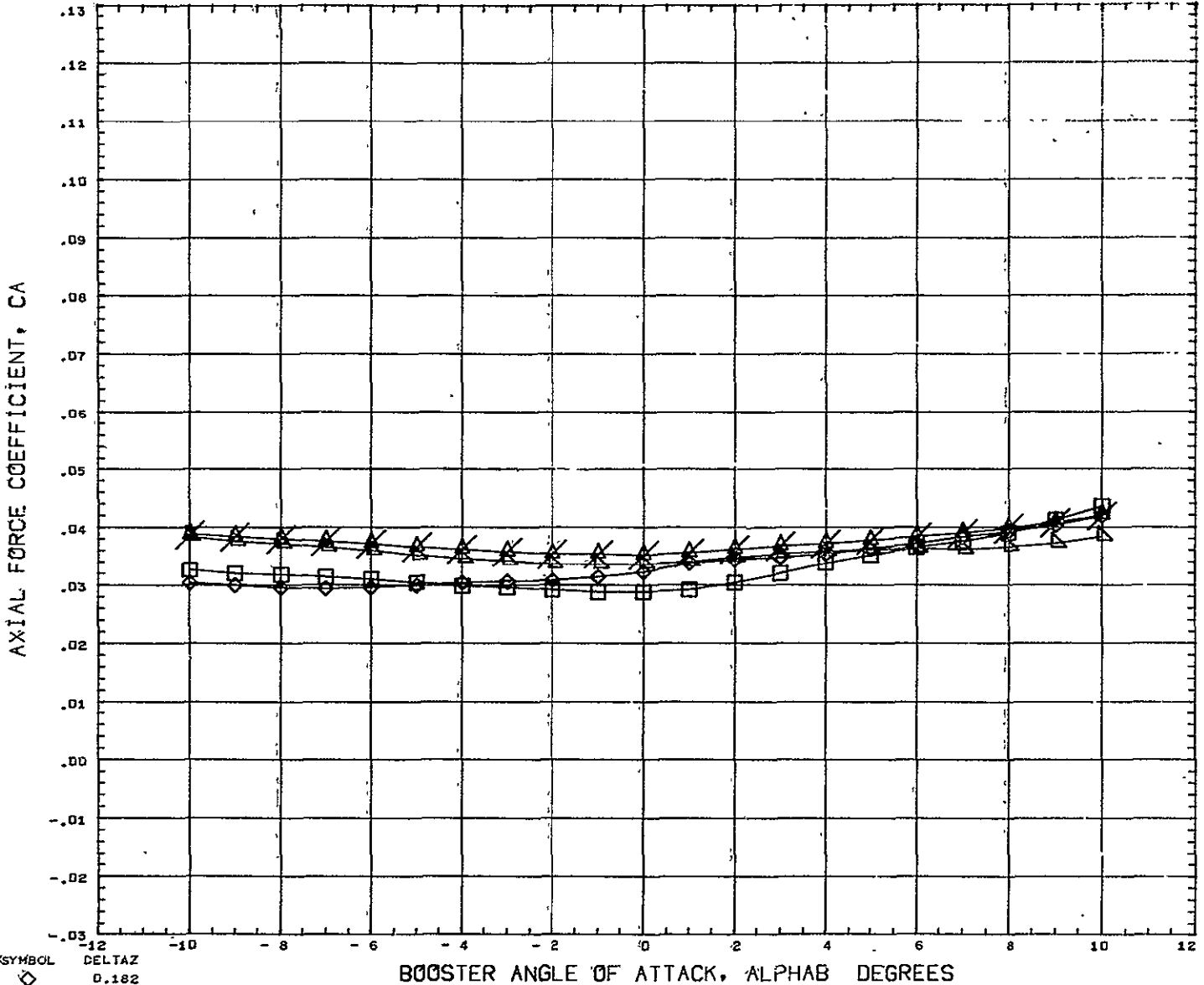

SYMBOL 	DELTA Z 0.182 0.228 0.352 10.000	PARAMETRIC VALUES BSTPOW 50.000 ORBROW 100.000 JELTAX 0.166 ALPHAI 10.100 MACH 5.010 ELVBST 0.000 ELVORB 0.000 BETA 0.000	REFERENCE INFORMATION REFS 23.6890 SQ IN REFL 4.1936 IN REFB 6.5000 IN XMRP 4.9170 IN YMRP 0.0000 IN ZMRP 1.3900 IN SCALE 0.0055
REFERENCE FILE			

# AEDC VA 1163 MDAC BOOSTER AND ORBITER TEST DATA AT MACH NUMBER 5

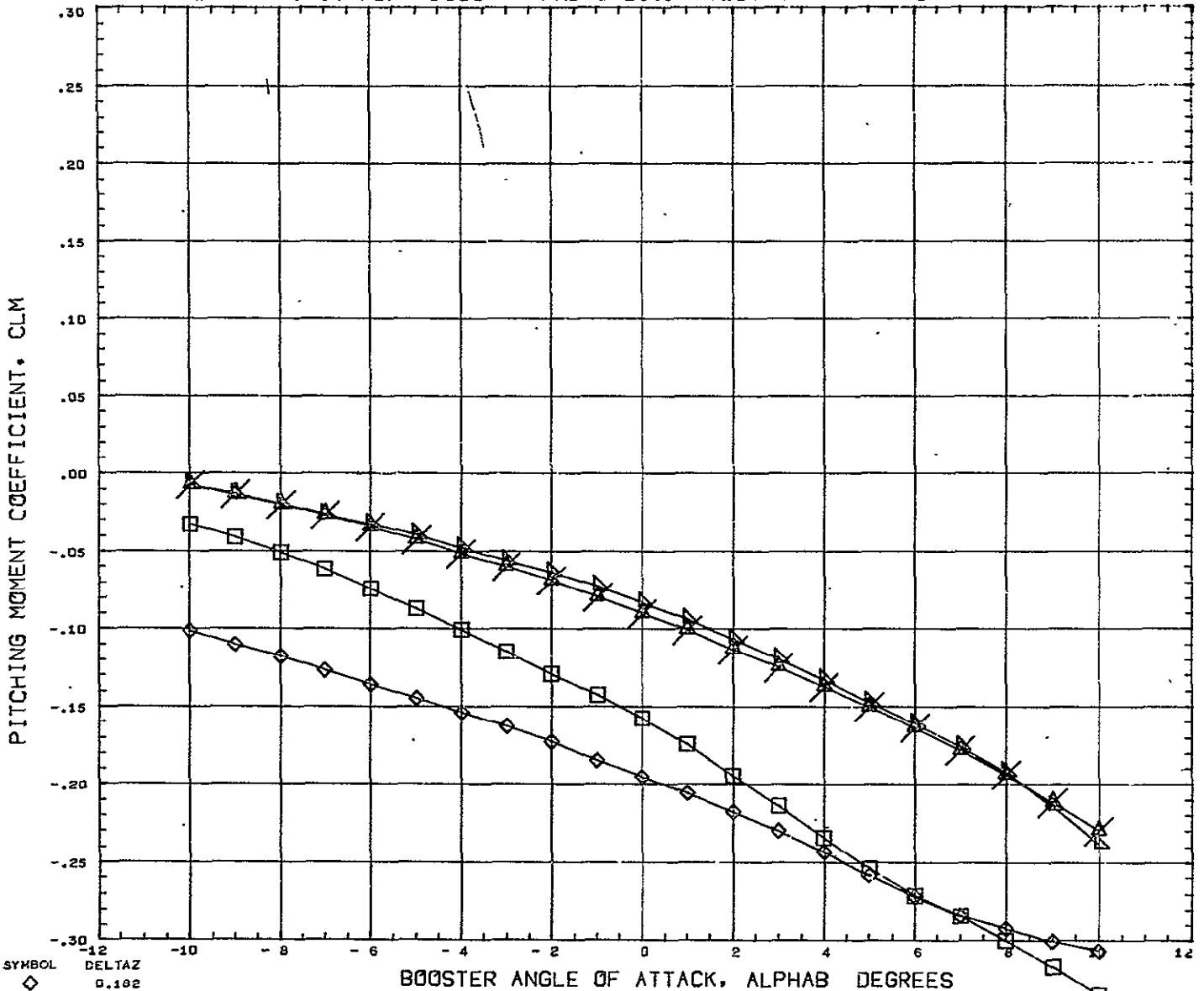

<p>SYMBOL</p> <p>◇</p> <p>□</p> <p>△</p>	<p>DELTA Z</p> <p>0.102</p> <p>0.228</p> <p>0.352</p> <p>10.000</p>	<p>PARAMETRIC VALUES</p> <p>BSTFOW 50.000 ORBPOW 100.000</p> <p>DELTA X 0.228 ALPHA I 10.160</p> <p>MACH 5.010 ELVBST 0.000</p> <p>ELVORB 0.000 BETA 0.000</p>	<p>REFERENCE INFORMATION</p> <p>REFS 23.6890 SQ IN</p> <p>REFL 4.1930 IN</p> <p>REFB 6.5000 IN</p> <p>XMRP 4.9170 IN</p> <p>YMRP 0.0000 IN</p> <p>ZMRP 1.3900 IN</p> <p>SCALE 0.0055</p>
--	---	--	--

REFERENCE FILE

# AEDC VA 1163 MDAC BOOSTER AND ORBITER TEST DATA AT MACH NUMBER 5

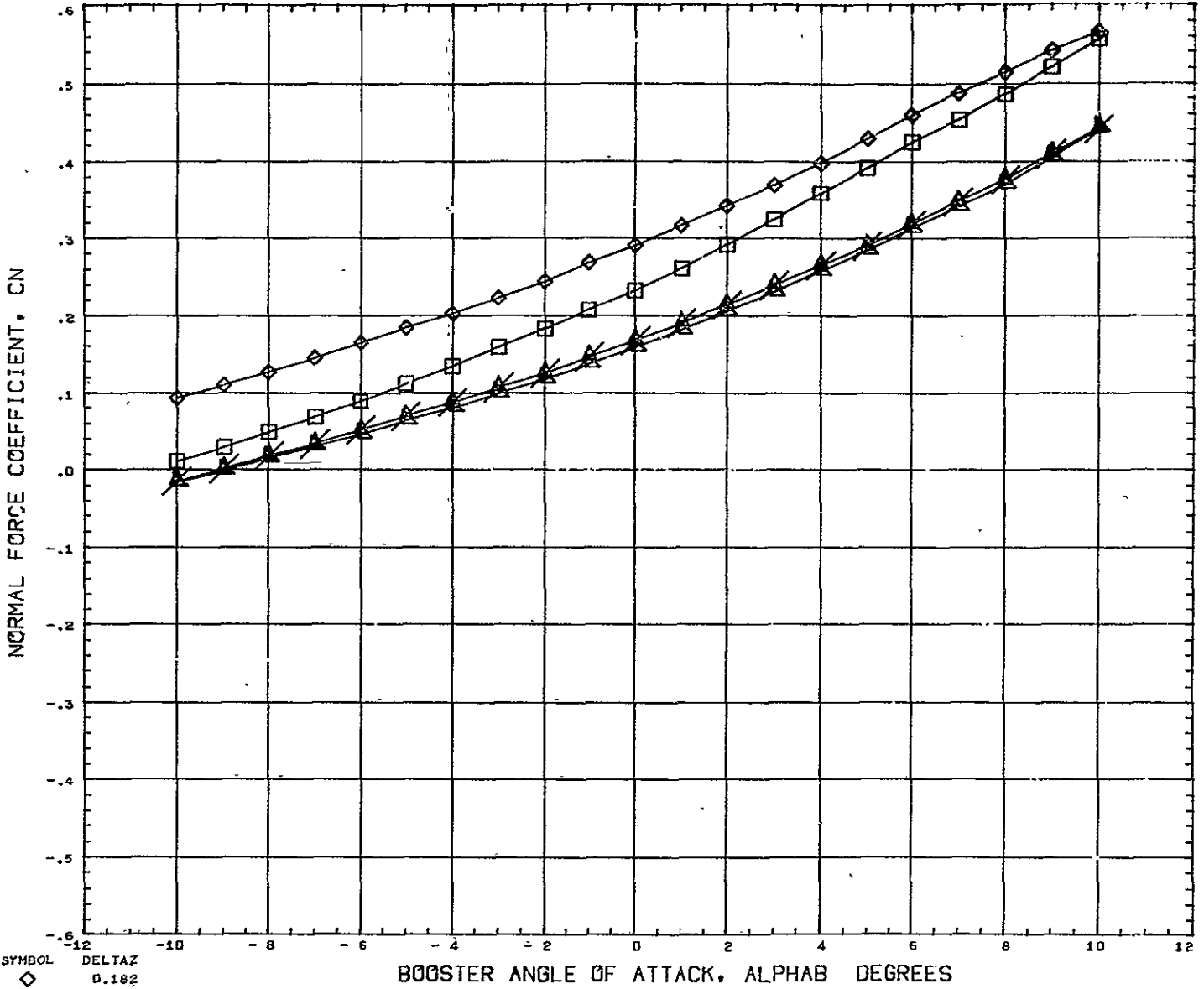

SYMBOL ◇ □ ▲	DELTAX 0.182 0.228 0.352 10.000	PARAMETRIC VALUES BSTPOW 50.000 ORBPOW 100.000 DELTAX 0.228 ALPHAI 10.100 MACH 5.010 ELVBST 0.000 ELVORB 0.000 BETA 0.000	REFERENCE INFORMATION REFS 23.6890 SQ IN REFL 4.1930 IN REFB 6.5000 IN XMRP 4.9170 IN YMRP 0.0000 IN ZMRP 1.3900 IN SCALE 0.0055
-----------------------	---	---	---

REFERENCE FILE

# AEDC VA 1163 MDAC BOOSTER AND ORBITER TEST DATA AT MACH NUMBER 5

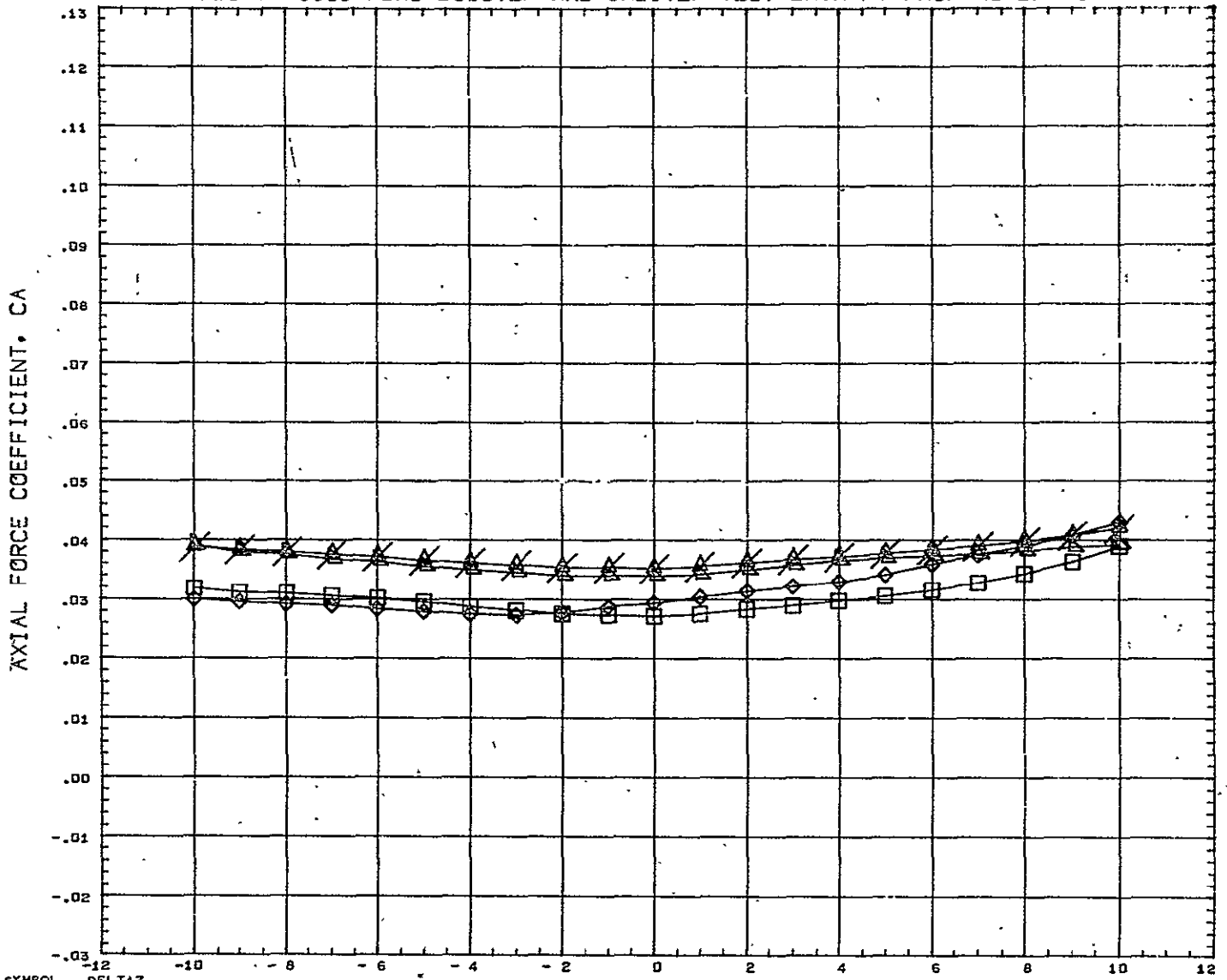

SYMBOL ◇ ◻ ▲	DELTAX 0.182 0.228 0.352 10.000	PARAMETRIC VALUES BSTFOW 50.000 ORBFOW 100.000 DELTAX 0.228 ALPHAI 10.100 MACH 5.010 ELVBST 0.000 ELVORB 0.000 BETA 0.000	REFERENCE INFORMATION REFS 23.6899 SQ IN REFL 4.1930 IN REFB 6.5000 IN XMRP 4.9170 IN YMRP 0.0000 IN ZMRP 1.3900 IN SCALE 0.0059
-----------------------	---	---	---

REFERENCE FILE

# AEDC VA 1163 MDAC BOOSTER AND ORBITER TEST DATA AT MACH NUMBER 5

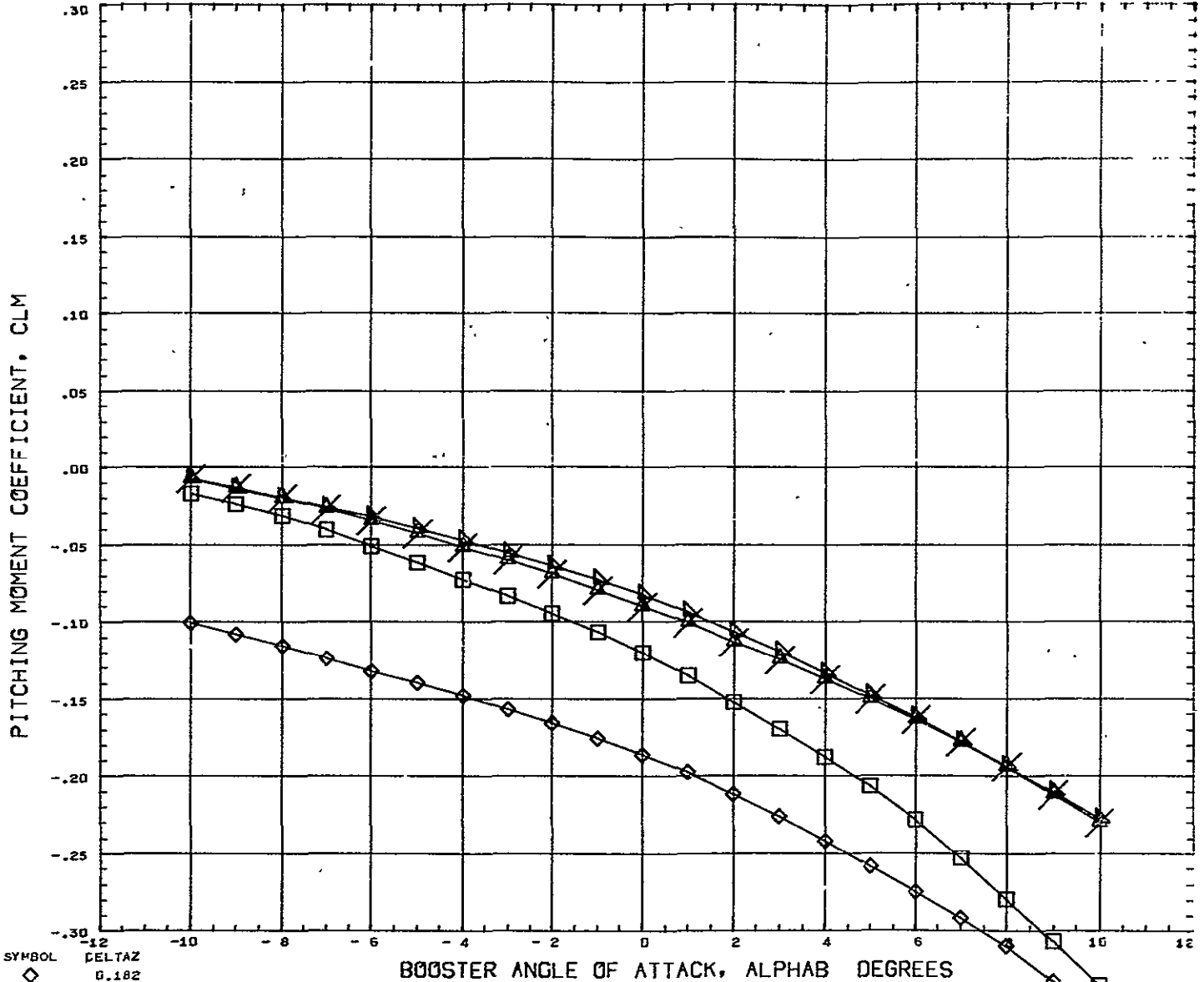

SYMBOL  
 ◇  
 □  
 △

DELTAZ  
 0.182  
 0.228  
 0.352  
 10.000

### PARAMETRIC VALUES

BSTPOW	50.000	ORBPW	100.000
DELTAZ	0.352	ALPHA1	10.100
MACH	5.010	ELVBST	0.000
ELVORB	0.000	BETA	0.000

REFERENCE FILE

### REFERENCE INFORMATION

REFS	23.6890	SQ IN.
REFL	4.1930	IN
REFB	6.5000	IN
XHRP	4.3170	IN
YHRP	0.0000	IN
ZHRP	1.3900	IN
SCALE	0.0055	

# AEDC VA 1163 MDAC BOOSTER AND ORBITER TEST DATA AT MACH NUMBER 5

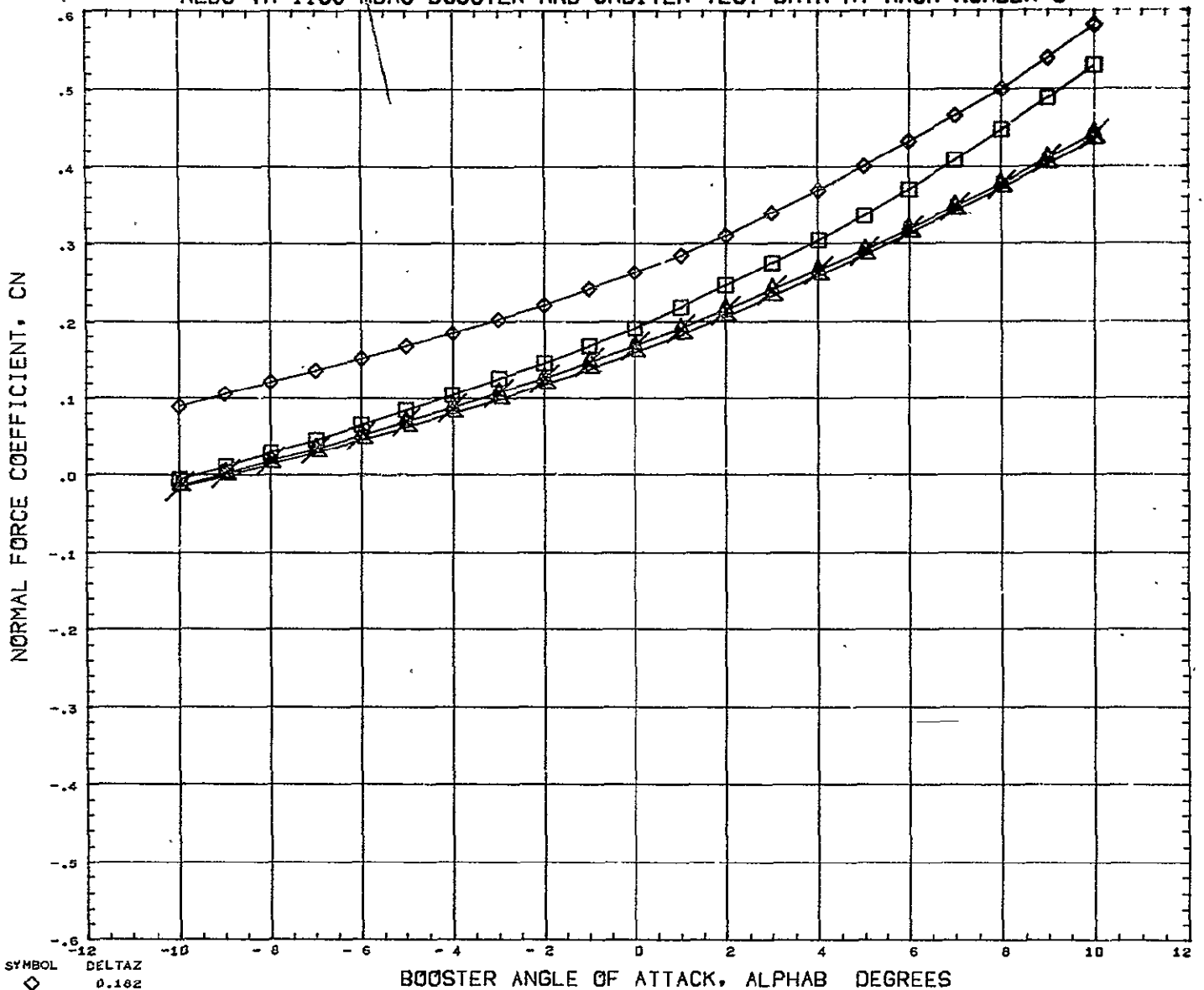

SYMBOL ◇ □ △ ×	DELTAX 0.182 0.228 0.352 10.000	PARAMETRIC VALUES BSTPOW 50.000 ORBPOW 100.000 DELTAX 0.352 ALPHA1 10.100 MACH 5.010 ELVBST 0.000 ELVORB 0.000 BETA 0.000	REFERENCE INFORMATION REFS 23.6890 SQ IN REFL 4.1930 IN REFB 6.5000 IN XMRP 4.9170 IN YMRP 0.0000 IN ZMRP 1.3900 IN SCALE 0.0055
----------------------------	---	---	---

REFERENCE FILE

# AEDC VA 1163 MDAC BOOSTER AND ORBITER TEST DATA AT MACH NUMBER 5

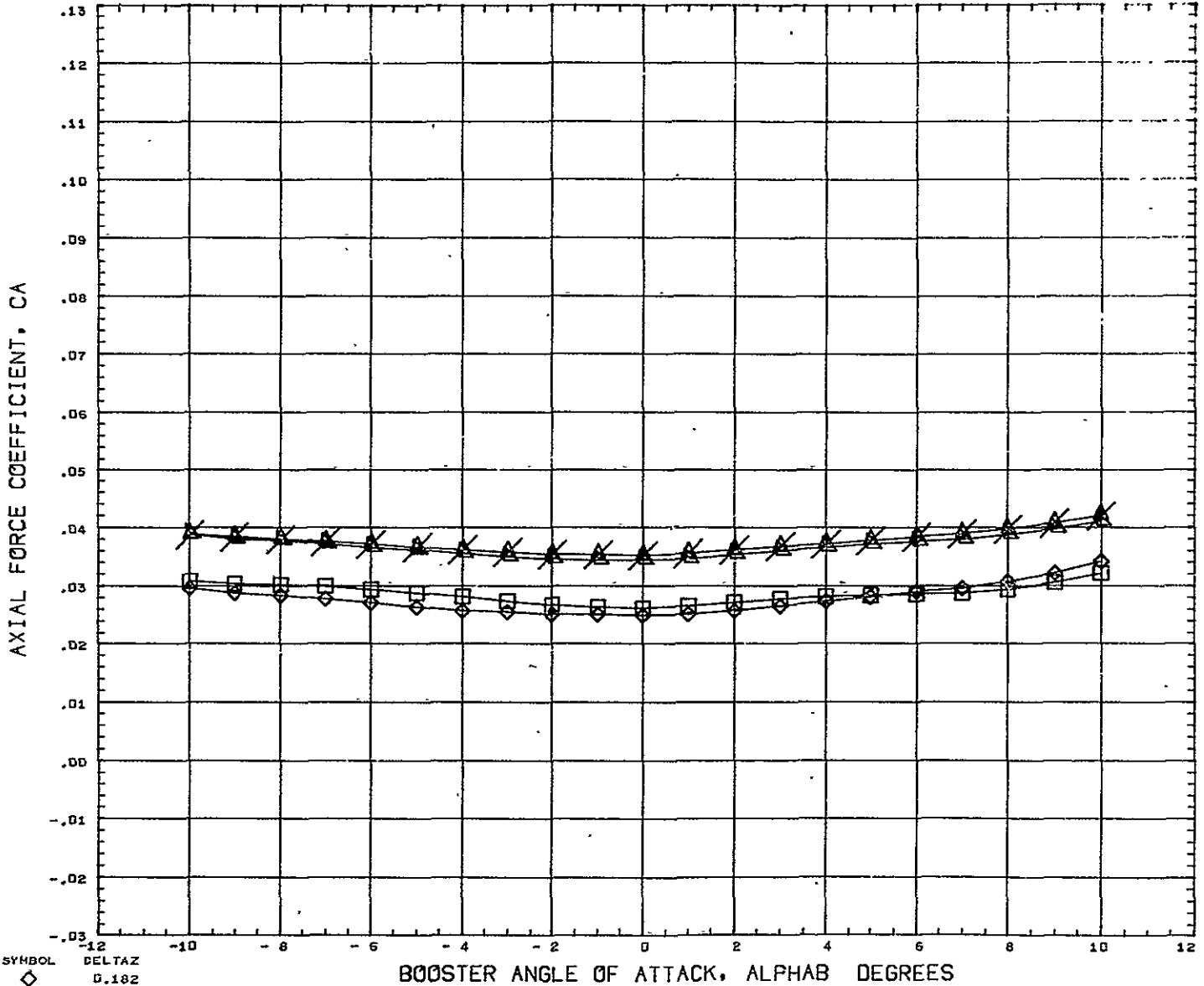

SYMBOL ◇ □ △	DELTAX 0.182 0.228 0.352 10.000	PARAMETRIC VALUES BSTFOW 50.000 ORBFOV 100.000 DELTAX 0.352 ALPHAI 10.100 MACH 5.010 ELVBST 0.000 ELVORB 0.000 BETA 0.000	REFERENCE INFORMATION REFS 23.6890 SQ IN REFL 4.1930 IN REFB 6.5000 IN XMRF 4.9470 IN YMRP 0.0000 IN ZMRP 1.3900 IN SCALE 0.0055
-----------------------	---	---	---

REFERENCE FILE



# AEDC VA 1163 MDAC BOOSTER AND ORBITER TEST DATA AT MACH NUMBER 5

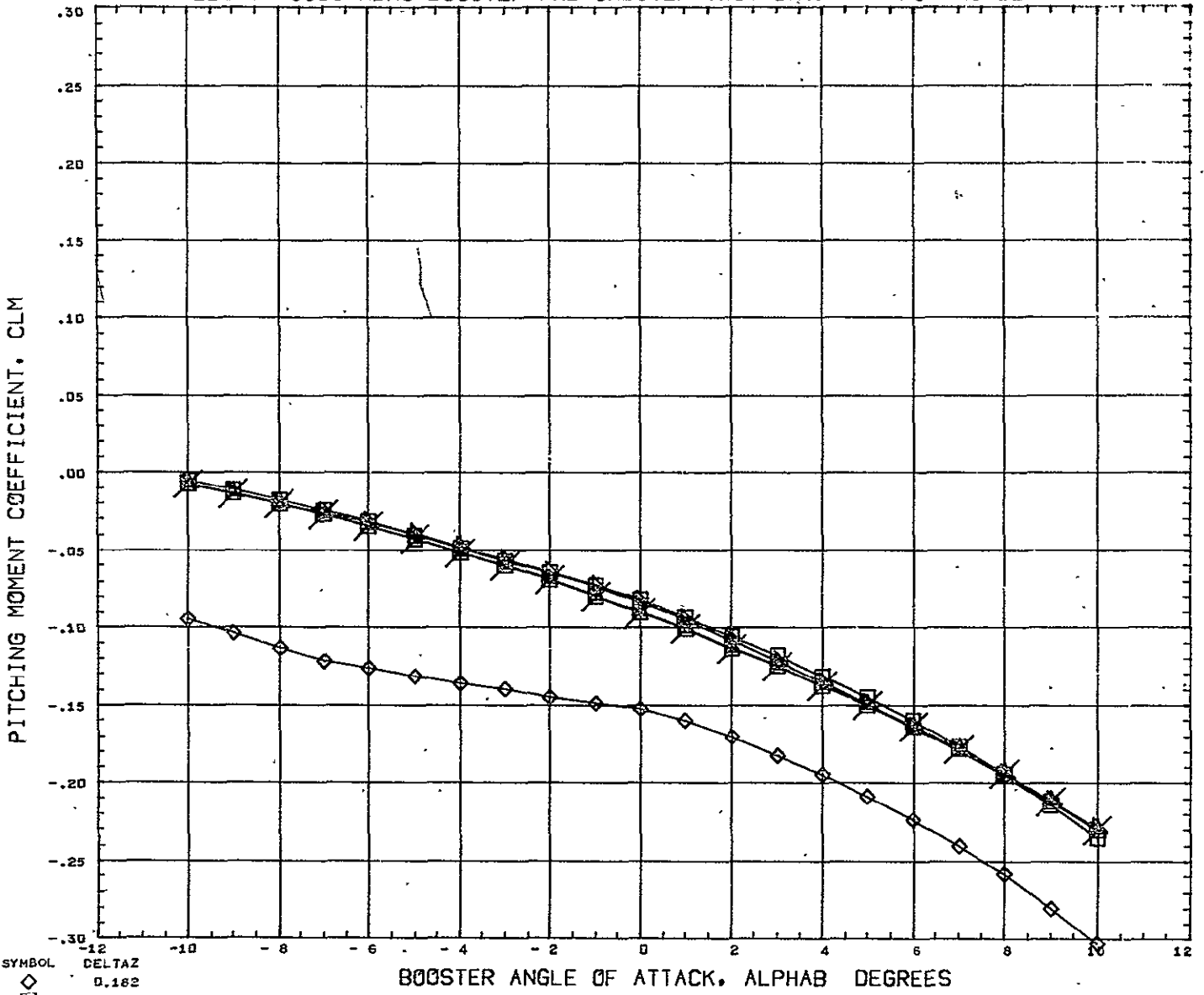

SYMBOL ◇ □ ▲	DELTA Z 0.182 0.228 0.352 0.599 10.000	<table border="0" style="width: 100%;"> <tr> <th colspan="4" style="text-align: center;">PARAMETRIC VALUES</th> </tr> <tr> <td>BSTPOW</td><td>50.000</td><td>ORBPOW</td><td>100.000</td> </tr> <tr> <td>DELTA X</td><td>0.501</td><td>ALPHA I</td><td>10.100</td> </tr> <tr> <td>MACH</td><td>5.010</td><td>ELVBST</td><td>0.000</td> </tr> <tr> <td>ELVORB</td><td>0.000</td><td>BETA</td><td>0.000</td> </tr> </table>	PARAMETRIC VALUES				BSTPOW	50.000	ORBPOW	100.000	DELTA X	0.501	ALPHA I	10.100	MACH	5.010	ELVBST	0.000	ELVORB	0.000	BETA	0.000	<table border="0" style="width: 100%;"> <tr> <th colspan="3" style="text-align: center;">REFERENCE INFORMATION</th> </tr> <tr> <td>REFS</td><td>23.6890</td><td>SQ IN</td> </tr> <tr> <td>REFL</td><td>4.1930</td><td>IN</td> </tr> <tr> <td>REFB</td><td>6.5000</td><td>IN</td> </tr> <tr> <td>XMRP</td><td>4.9170</td><td>IN</td> </tr> <tr> <td>YMRF</td><td>0.0000</td><td>IN</td> </tr> <tr> <td>ZMRF</td><td>1.3900</td><td>IN</td> </tr> <tr> <td>SCALE</td><td>0.0055</td><td></td> </tr> </table>	REFERENCE INFORMATION			REFS	23.6890	SQ IN	REFL	4.1930	IN	REFB	6.5000	IN	XMRP	4.9170	IN	YMRF	0.0000	IN	ZMRF	1.3900	IN	SCALE	0.0055	
PARAMETRIC VALUES																																															
BSTPOW	50.000	ORBPOW	100.000																																												
DELTA X	0.501	ALPHA I	10.100																																												
MACH	5.010	ELVBST	0.000																																												
ELVORB	0.000	BETA	0.000																																												
REFERENCE INFORMATION																																															
REFS	23.6890	SQ IN																																													
REFL	4.1930	IN																																													
REFB	6.5000	IN																																													
XMRP	4.9170	IN																																													
YMRF	0.0000	IN																																													
ZMRF	1.3900	IN																																													
SCALE	0.0055																																														

REFERENCE FILE

# AEDC VA 1163 MDAC BOOSTER AND ORBITER TEST DATA AT MACH NUMBER 5

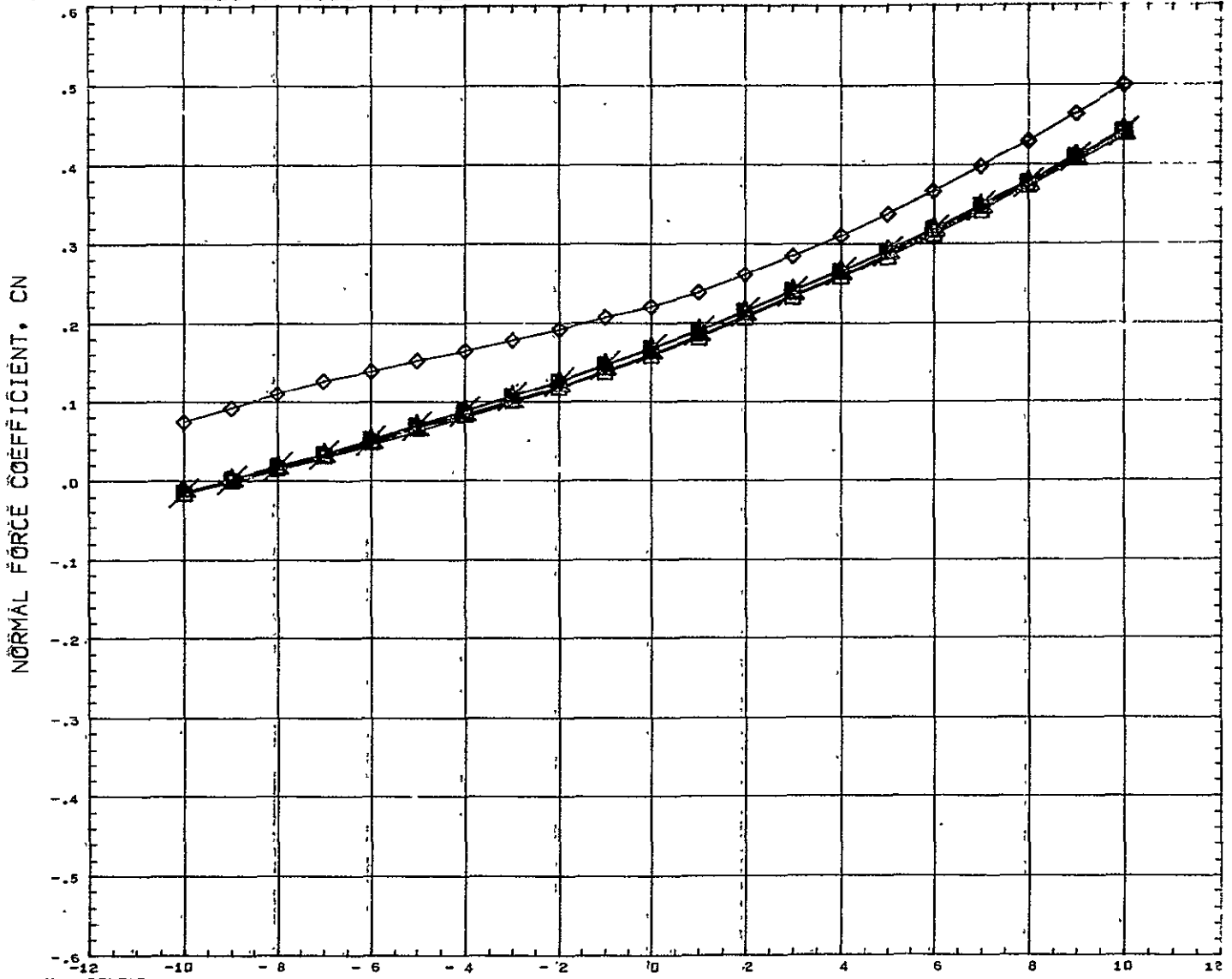

SYMBOL ◇ ◻ ▲	DELTAZ 0.182 0.228 0.352 0.599 10.000	PARAMETRIC VALUES BSTPOW 50.000 ORBPOW 100.000 DELTAX 0.501 ALPHAI 10.100 MACH 5.010 ELVBST 0.000 ELVORB 0.000 BETA 0.000	REFERENCE INFORMATION REFS 23.6890 SQ IN REFL 4.1930 IN REFB 6.5000 IN XMRP 4.9370 IN YMRP 0.0000 IN ZMRP 1.3900 IN SCALE 0.0055
REFERENCE FILE			

# AEDC VA 1163 MDAC BOOSTER AND ORBITER TEST DATA AT MACH NUMBER 5

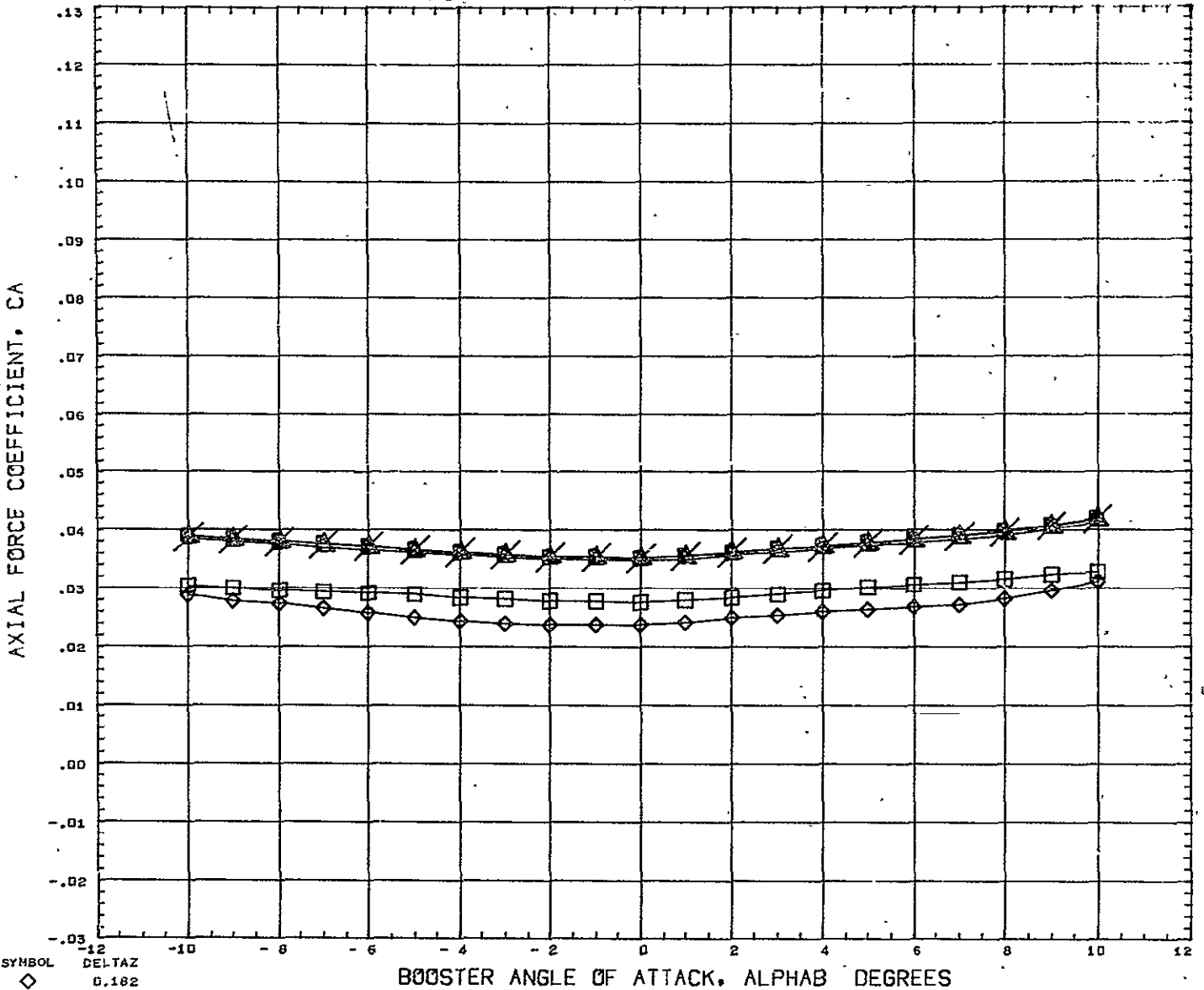

SYMBOL

DELTA Z  
 0.182  
 0.228  
 0.352  
 0.599  
 10.000

PARAMETRIC VALUES  
 BSTPOW 50.000 ORBPOW 100.000  
 DELTAX 0.501 ALPHAI 10.100  
 MACH 5.010 ELVBST 0.000  
 ELVORB 0.000 BETA 0.000

REFERENCE INFORMATION  
 REFS 23.6890 SQ IN  
 REFL 4.1930 IN  
 REFB 6.5000 IN  
 XMRP 4.9176 IN  
 YMRP 0.0000 IN  
 ZMRP 1.3900 IN  
 SCALE 0.0055

REFERENCE FILE

# AEDC VA 1163 MDAC BOOSTER AND ORBITER TEST DATA AT MACH NUMBER 5

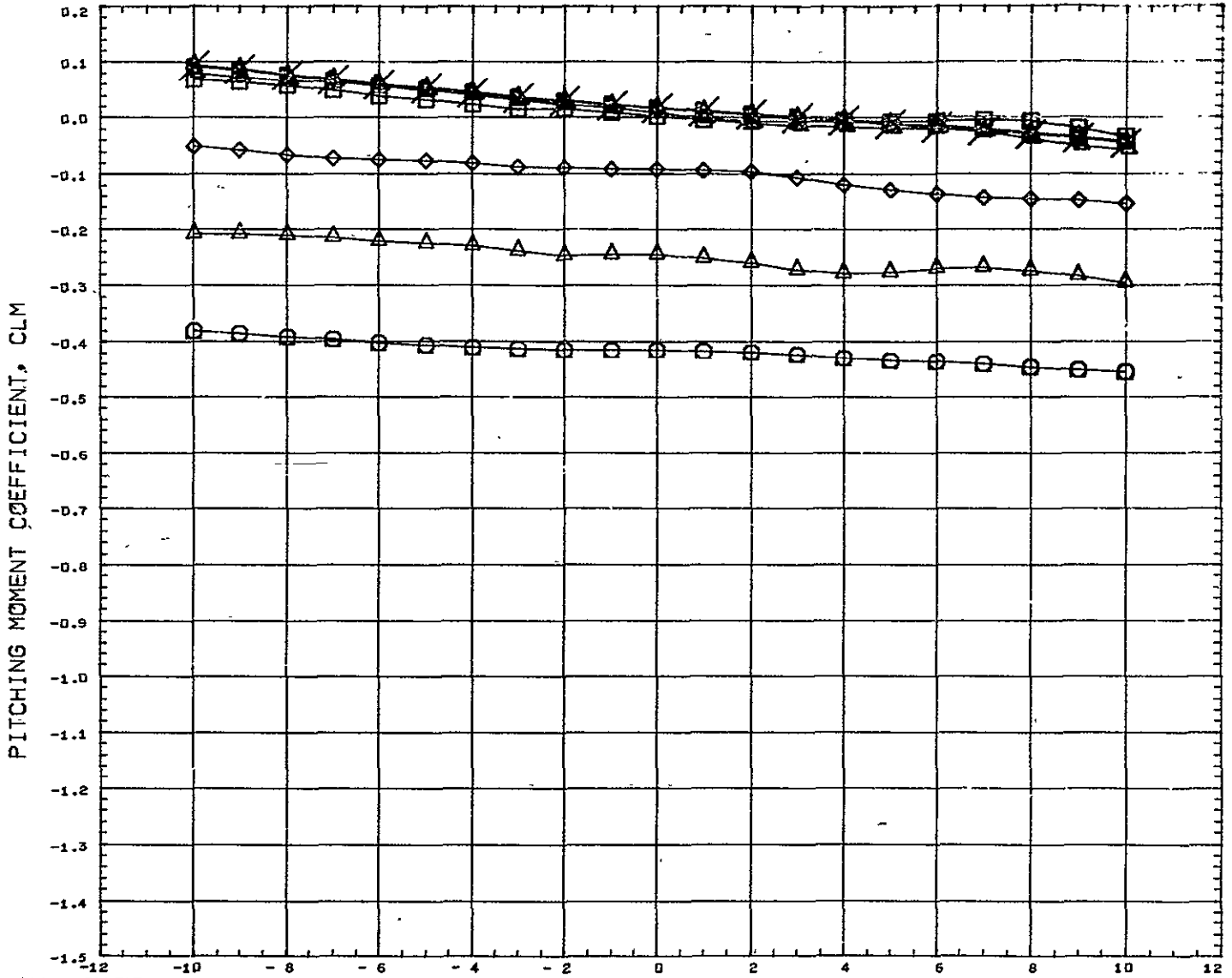

SYMBOL □ ◇ △ ○ ×	DELTAZ 0.120 0.151 0.182 0.228 0.352 0.599 10.000	<b>PARAMETRIC VALUES</b> BSTPOW 50.000 ORBPOW 100.000 DELTAX - 0.391 ALPHAI - 4.900 MACH 5.010 ELVBST 0.000 ELVORB 0.000 BETA 0.100	<b>REFERENCE INFORMATION</b> REFS 23.6890 SQ IN REFL 4.1930 IN REFB 6.5000 IN XMRP 4.9170 IN YMRP 0.0005 IN ZMRP 1.3900 IN SCALE 0.0055
---------------------------------	--	---	--

REFERENCE FILE

# AEDC VA 1163 MDAC BOOSTER AND ORBITER TEST DATA AT MACH NUMBER 5

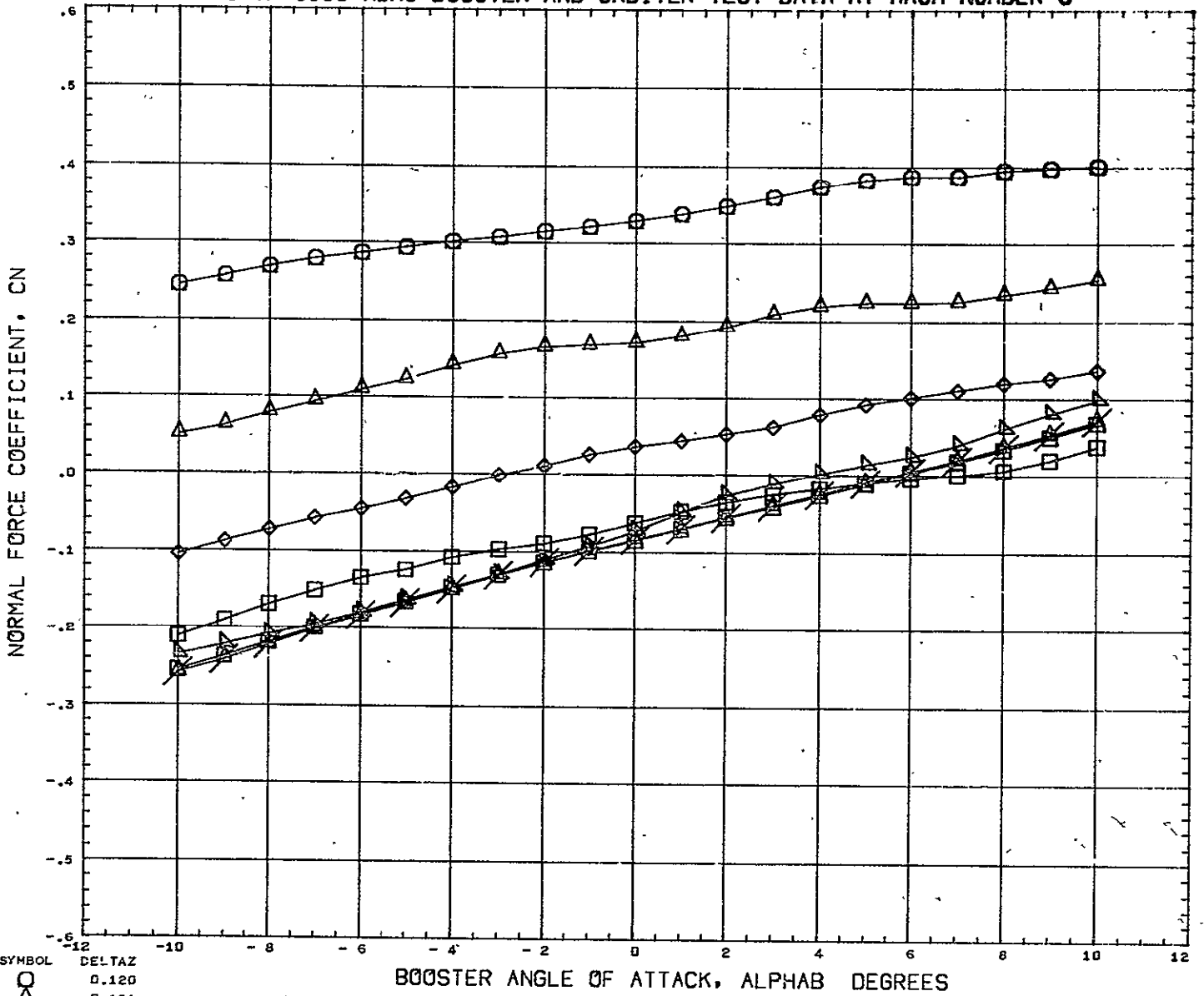

SYMBOL ○ △ ◇ □ ▽ ×	DELTAX 0.120 0.151 0.182 0.228 0.352 0.599 10.000	PARAMETRIC VALUES BSTFOW 50.000 ORBPOW 100.000 DELTAX - 0.391 ALPHAI - 4.900 MACH 5.010 ELVBST 0.000 ELVORB 0.000 BETA 0.000	REFERENCE INFORMATION REFS 23.6890 SQ IN REFL 4.1950 IN REFB 6.5000 IN XMRF 4.9170 IN YMRF 0.0000 IN ZMRF 1.3900 IN SCALE 0.0055
--------------------------------------	--	--	---

REFERENCE FILE

AEDC VA 1163 MDAC BOOSTER AND ORBITER TEST DATA AT MACH NUMBER 5

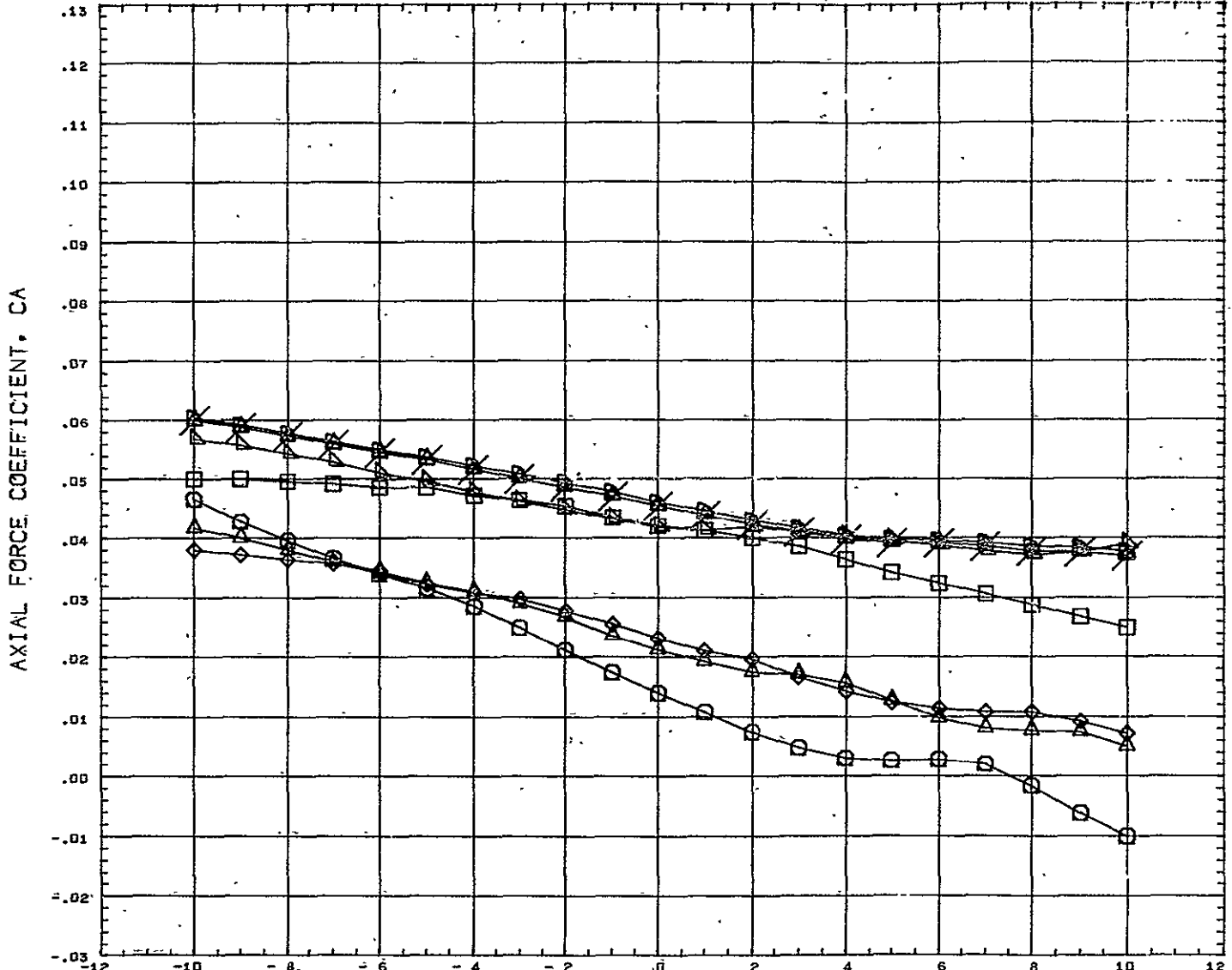

SYMBOL	DELTA Z	PARAMETRIC VALUES				REFERENCE INFORMATION		
○	0.120							
○	0.151							
○	0.182	BSTPOW	50.000	ORBPOW	100.000	REFS	23.6890	SQ IN
○	0.220	DELTA X	- 0.391	ALPHA I	- 4.900	REFL	4.1930	IN
○	0.352	MACH	5.010	FLVBST	0.000	REFB	6.5000	IN
○	0.599	ELVORB	0.000	BETA	0.000	XMRP	4.9170	IN
○	10.000					YMRP	0.0000	IN
						ZMRP	1.3900	IN
						SCALE	0.0055	
		REFERENCE FILE						

# AEDC VA 1163 MDAC BOOSTER AND ORBITER TEST DATA AT MACH NUMBER 5

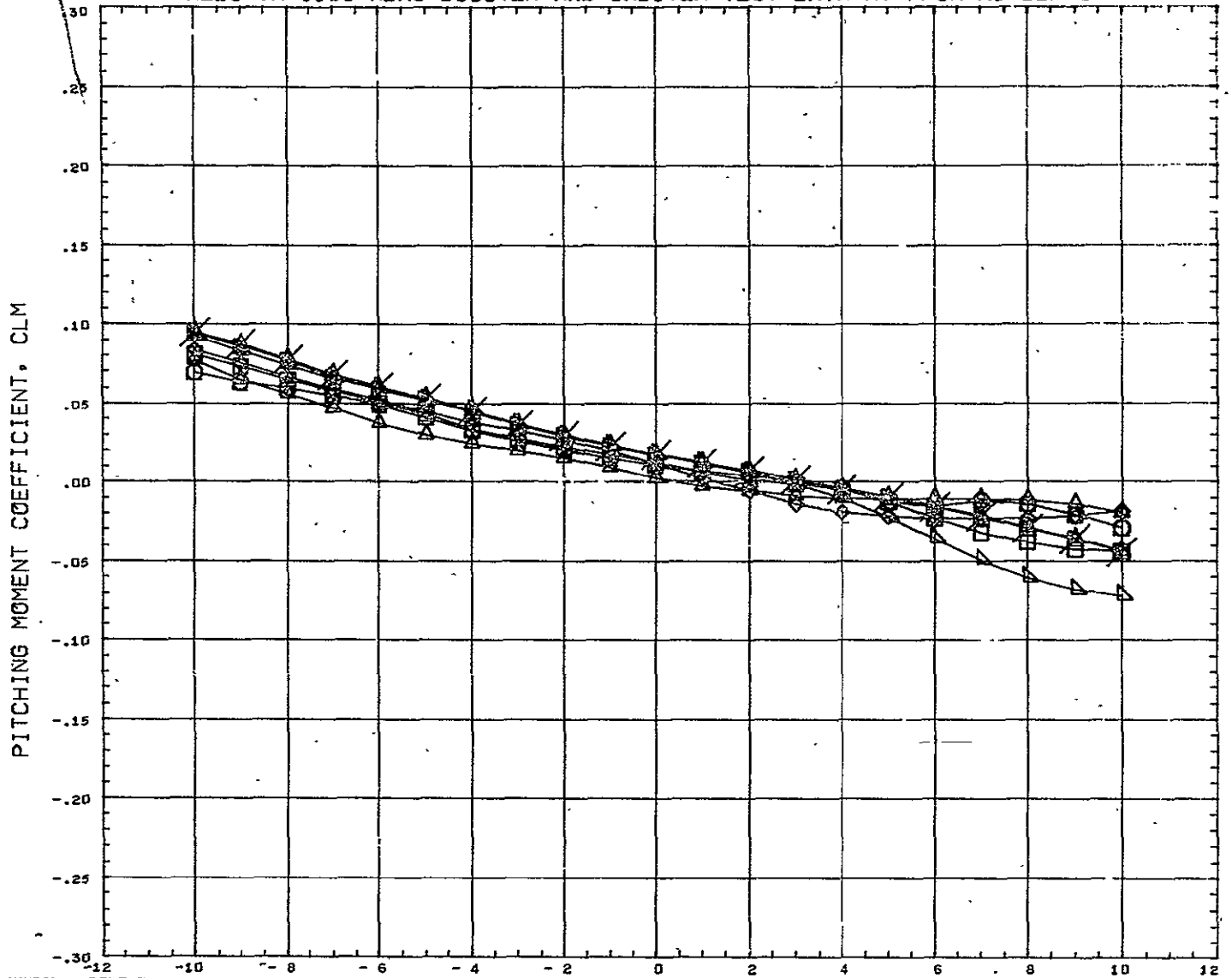

SYMBOL	DELTA Z	PARAMETRIC VALUES				REFERENCE INFORMATION		
○	0.120							
□	0.151							
◇	0.182	BSTPOW	50.000	ORBPOW	100.000	REFS	23.6890	SQ IN
△	0.228	DELTA X	- 0.143	ALPHA I	- 4.900	REFL	4.1930	IN
▽	0.352	MACH	5.010	ELVBST	0.000	REFB	6.5000	IN
◇	0.599	ELVORB	0.000	BETA	0.000	XMRP	4.9170	IN
△	10.000					YMRP	0.0000	IN
						ZMRP	1.3900	IN
						SCALE	0.0055	

REFERENCE FILE

# AEDC VA 1163 MDAC BOOSTER AND ORBITER TEST DATA AT MACH NUMBER 5

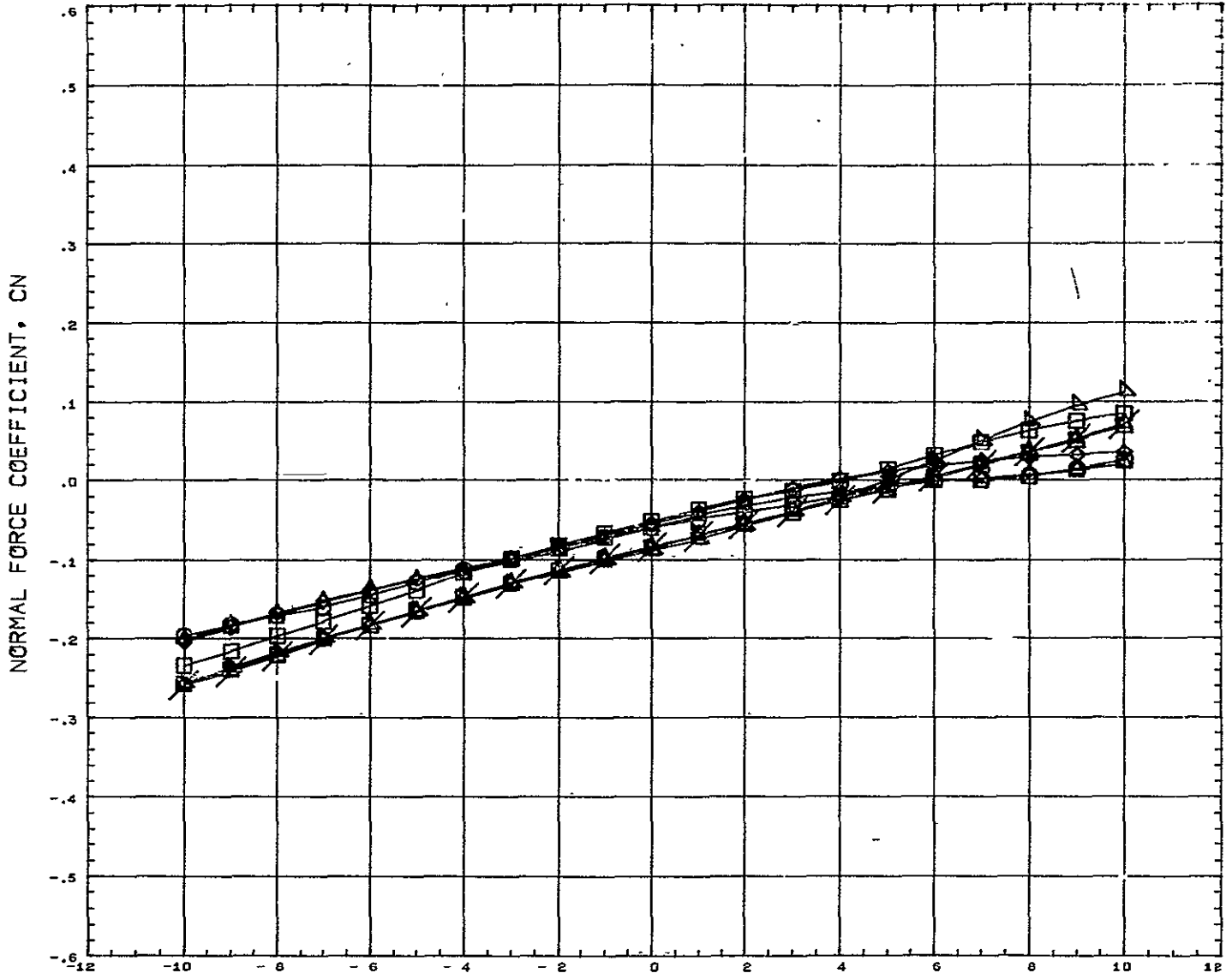

SYMBOL	DELTAZ	PARAMETRIC VALUES		REFERENCE INFORMATION	
○	0.120			REFS	23.6890 SQ IN
◇	0.151	BSTPOW	50.000	ORBPOW	100.000
◊	0.182	DELTAZ	- 0.143	ALPHAI	- 4.900
□	0.228	MACH	5.010	FLVBST	0.000
△	0.352	ELVORB	0.000	BETA	0.000
▽	0.599			REFL	4.1930 IN
X	10.000			REFB	6.5000 IN
				XMRP	4.9170 IN
				YMRP	0.0000 IN
				ZMRP	1.3900 IN
				SCALE	0.0055

REFERENCE FILE



# AEDC VA 1163 MDAC BOOSTER AND ORBITER TEST DATA AT MACH NUMBER 5

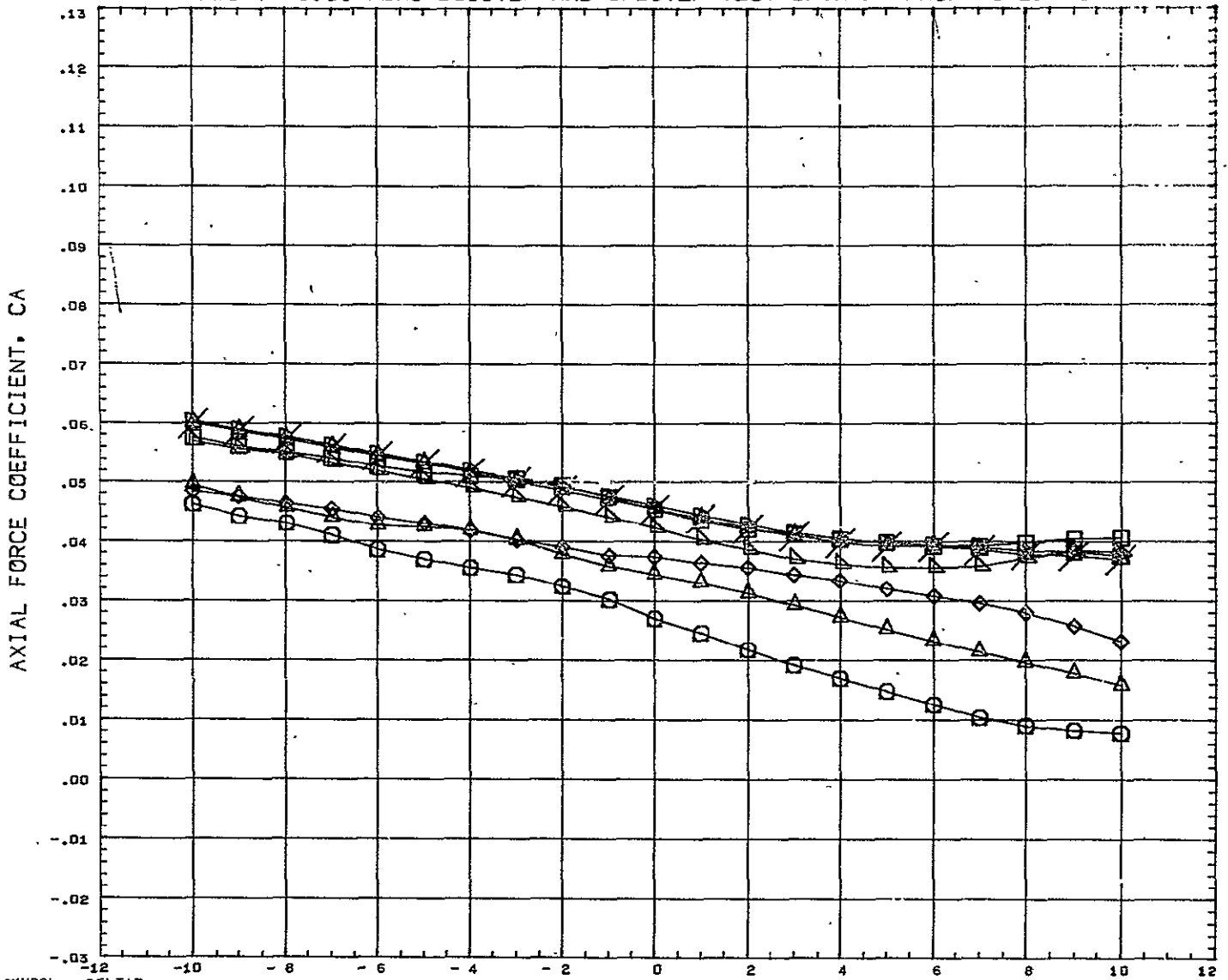

SYMBOL ○ △ ◇ □ ◻ ×	DELTAZ 0.120 0.151 0.182 0.228 0.352 0.599 10.000	<table border="0" style="width: 100%;"> <tr> <th colspan="4" style="text-align: center;">PARAMETRIC VALUES</th> </tr> <tr> <td style="width: 25%;">BSTPOW</td> <td style="width: 25%;">50.000</td> <td style="width: 25%;">ORBPOW</td> <td style="width: 25%;">100.000</td> </tr> <tr> <td>DELTA X</td> <td>0.143</td> <td>ALPHA I</td> <td>4.900</td> </tr> <tr> <td>MACH</td> <td>5.010</td> <td>FLVBST</td> <td>0.000</td> </tr> <tr> <td>ELVORB</td> <td>0.000</td> <td>BETA</td> <td>0.000</td> </tr> </table>	PARAMETRIC VALUES				BSTPOW	50.000	ORBPOW	100.000	DELTA X	0.143	ALPHA I	4.900	MACH	5.010	FLVBST	0.000	ELVORB	0.000	BETA	0.000	<table border="0" style="width: 100%;"> <tr> <th colspan="3" style="text-align: center;">REFERENCE INFORMATION</th> </tr> <tr> <td style="width: 33%;">REFS</td> <td style="width: 33%;">23.6890</td> <td style="width: 33%;">SQ IN</td> </tr> <tr> <td>REFL</td> <td>4.1950</td> <td>IN</td> </tr> <tr> <td>REFB</td> <td>6.5000</td> <td>IN</td> </tr> <tr> <td>XMRP</td> <td>4.9170</td> <td>IN</td> </tr> <tr> <td>YMRP</td> <td>0.0000</td> <td>IN</td> </tr> <tr> <td>ZMRP</td> <td>1.3900</td> <td>IN</td> </tr> <tr> <td>SCALE</td> <td>0.0055</td> <td></td> </tr> </table>	REFERENCE INFORMATION			REFS	23.6890	SQ IN	REFL	4.1950	IN	REFB	6.5000	IN	XMRP	4.9170	IN	YMRP	0.0000	IN	ZMRP	1.3900	IN	SCALE	0.0055	
PARAMETRIC VALUES																																															
BSTPOW	50.000	ORBPOW	100.000																																												
DELTA X	0.143	ALPHA I	4.900																																												
MACH	5.010	FLVBST	0.000																																												
ELVORB	0.000	BETA	0.000																																												
REFERENCE INFORMATION																																															
REFS	23.6890	SQ IN																																													
REFL	4.1950	IN																																													
REFB	6.5000	IN																																													
XMRP	4.9170	IN																																													
YMRP	0.0000	IN																																													
ZMRP	1.3900	IN																																													
SCALE	0.0055																																														

REFERENCE FILE

# AEDC VA 1163 MDAC BOOSTER AND ORBITER TEST DATA AT MACH NUMBER 5

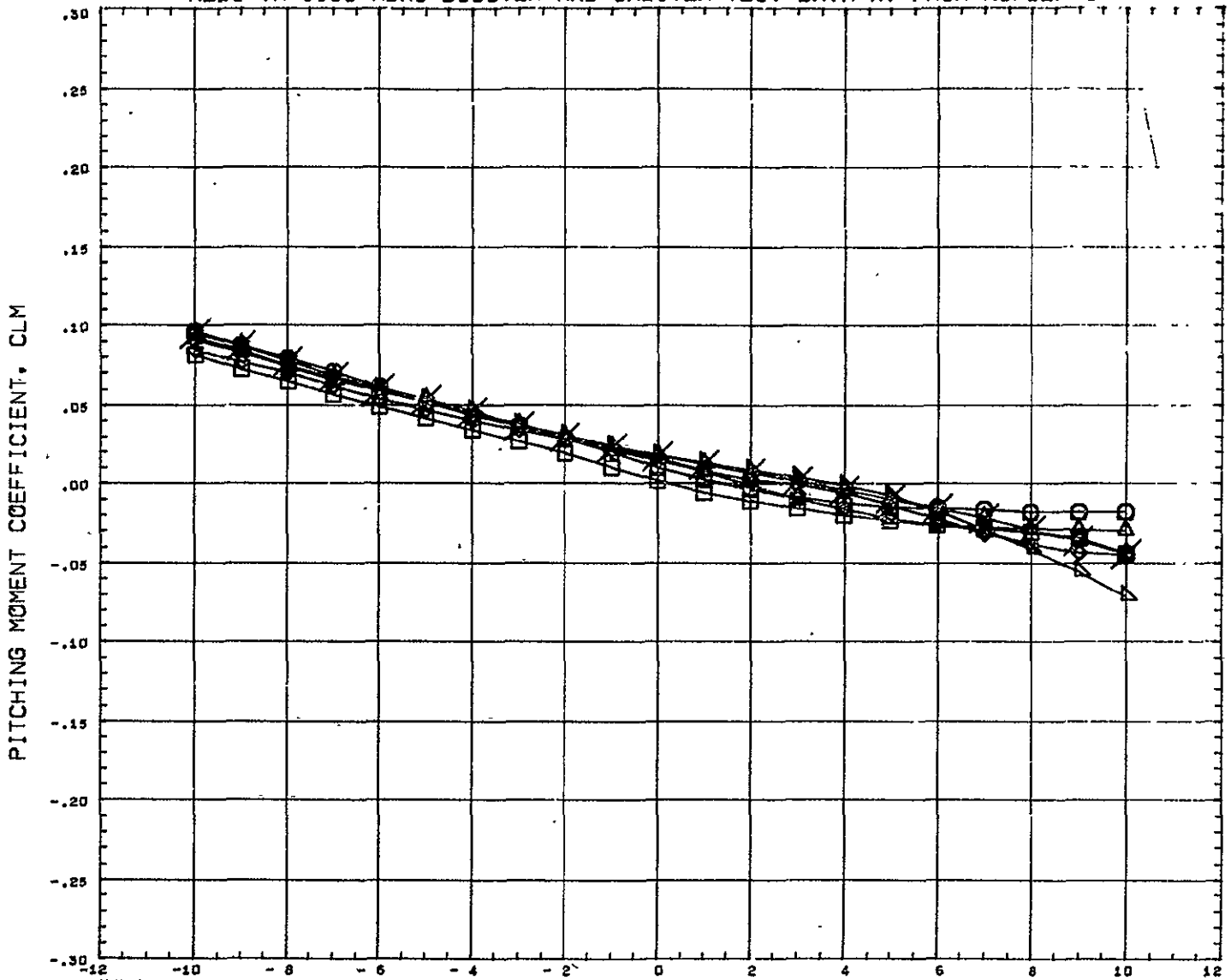

SYMBOL	DELTAZ	BOOSTER ANGLE OF ATTACK, ALPHAB DEGREES				REFERENCE INFORMATION		
	0.120				REFS	23.6890	50 IN	
	0.151	PARAMETRIC VALUES				REFL	4.1930	1N
	0.182	BSTPOW	50.000	ORBPOW	100.000	REFB	6.5000	1N
	0.228	DELTAZ	- 0.019	ALPHA1	- 4.900	XMRP	4.9170	1N
	0.352	MACH	5.010	ELVBST	0.000	YMRP	0.6000	1N
	10.000	ELVORB	0.000	BETA	0.000	ZMRP	1.3900	1N
						SCALE	0.0055	

REFERENCE FILE

# AEDC VA 1163 MDAC BOOSTER AND ORBITER TEST DATA AT MACH NUMBER 5

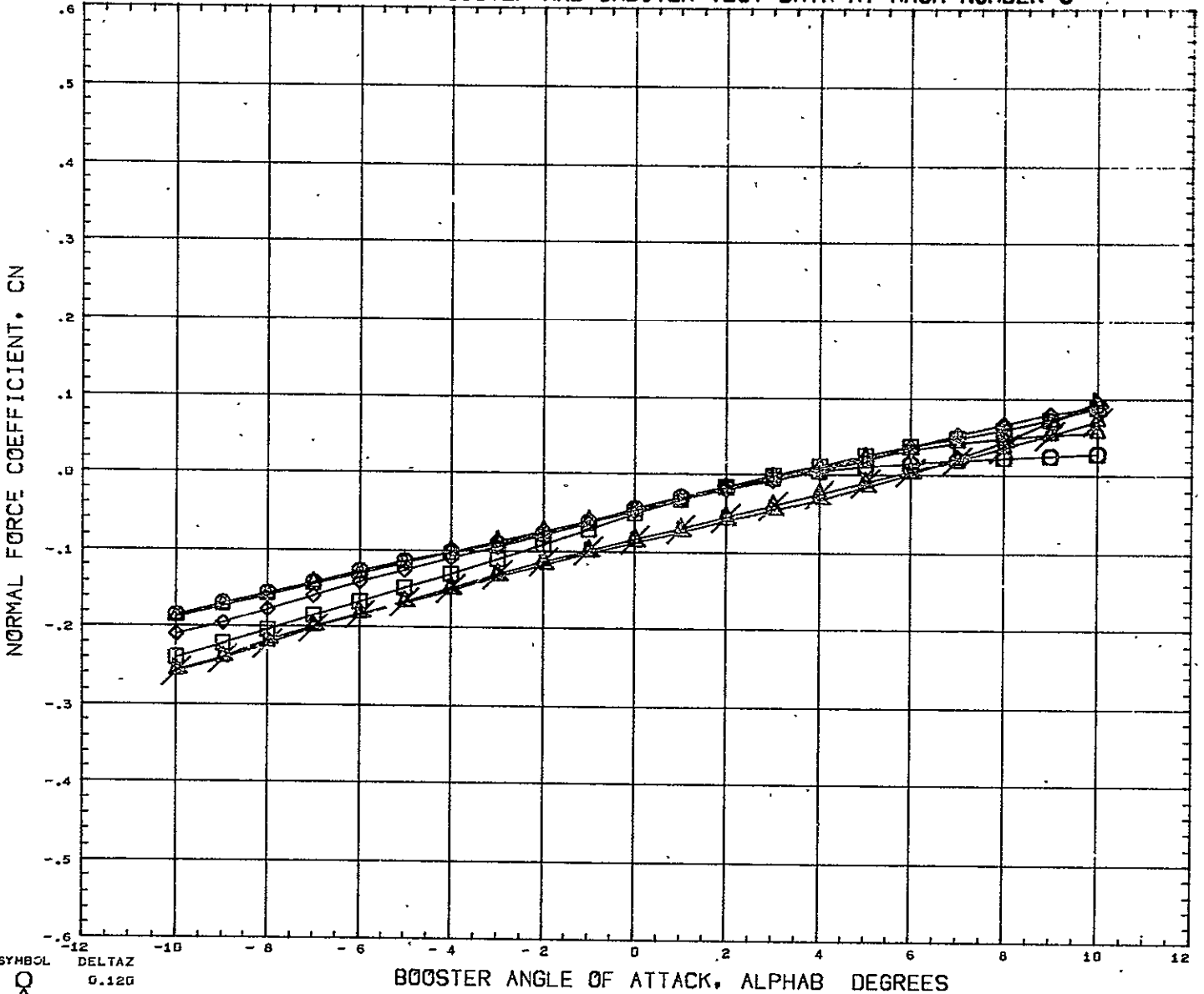

SYMBOL ○ □ △ ◇ ○ □ △ ◇	DELTAZ 0.120 0.151 0.182 0.228 0.352 10.050	PARAMETRIC VALUES BSTPOW    50.000    ORBPOW    100.000 DELTAX    - 0.019    ALPHAI    - 4.900 MACH       5.010    ELVBST    0.000 ELVORB     0.000    BETA       0.000	REFERENCE INFORMATION REFS       23.6890    SQ IN REFL       4.1930    IN REFB       6.5000    IN XMRP       4.9170    IN YMRP       0.0000    IN ZMRP       1.3900    IN SCALE      0.0055
REFERENCE FILE			

# AEDC VA 1163 MDAC BOOSTER AND ORBITER TEST DATA AT MACH NUMBER 5

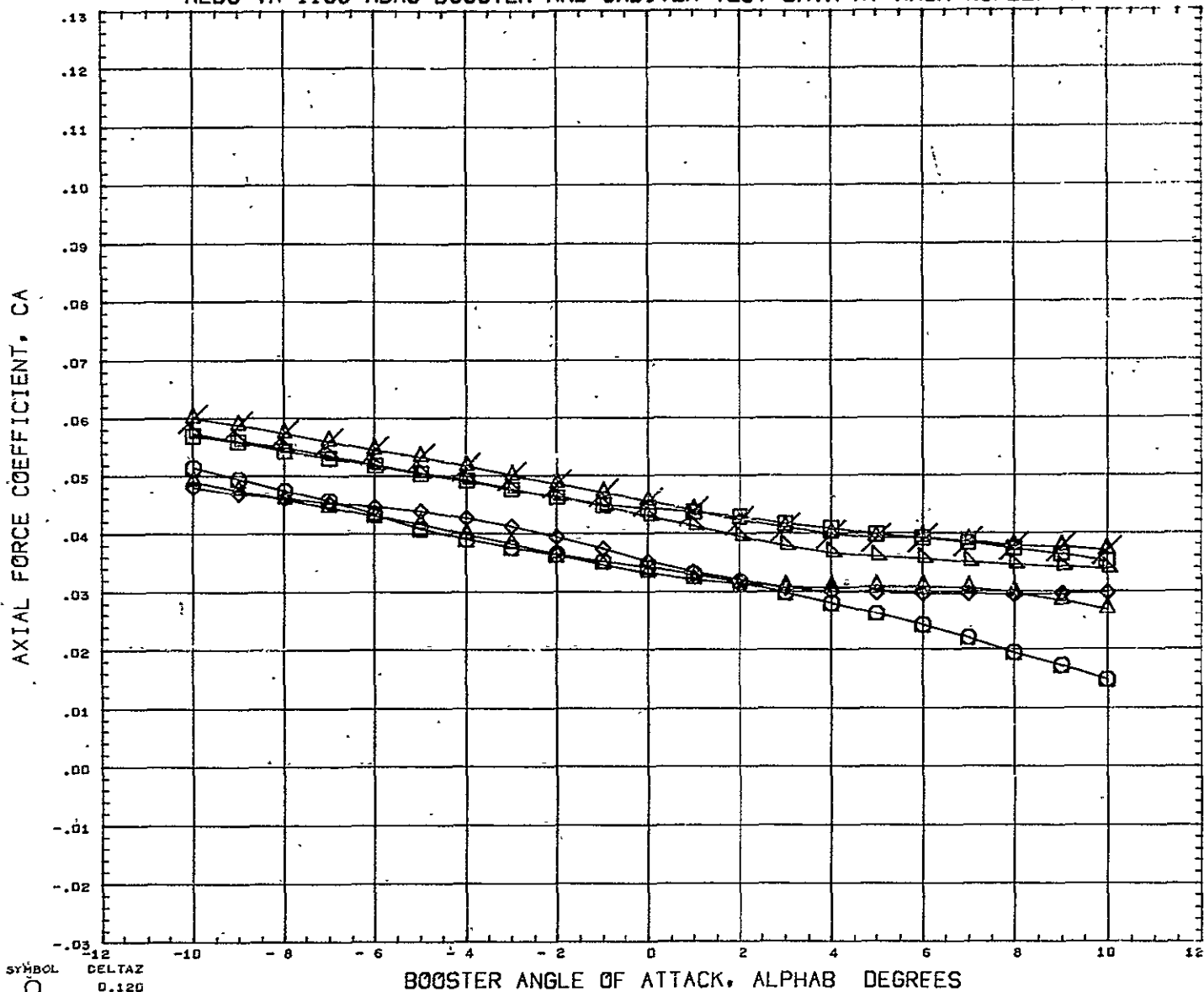

SYMBOL ○ ◇ □ △ ☆	DELTA Z	PARAMETRIC VALUES				REFERENCE INFORMATION		
	0.120	BSTPOW	50.000	ORBPOW	100.000	REFS	23.6890	SQ IN
	0.151	DELTA X	- 0.019	ALPHA I	- 4.900	REFL	4.1930	IN
	0.228	MACH	5.010	ELVBST	0.000	REFB	6.5000	IN
	0.352	ELVORB	0.000	BETA	0.000	XMRP	4.9170	IN
	10.000					YMRP	0.0000	IN
						ZMRP	1.3900	IN
						SCALE	0.0055	

REFERENCE FILE

# AEDC VA 1163 MDAC BOOSTER AND ORBITER TEST DATA AT MACH NUMBER 5

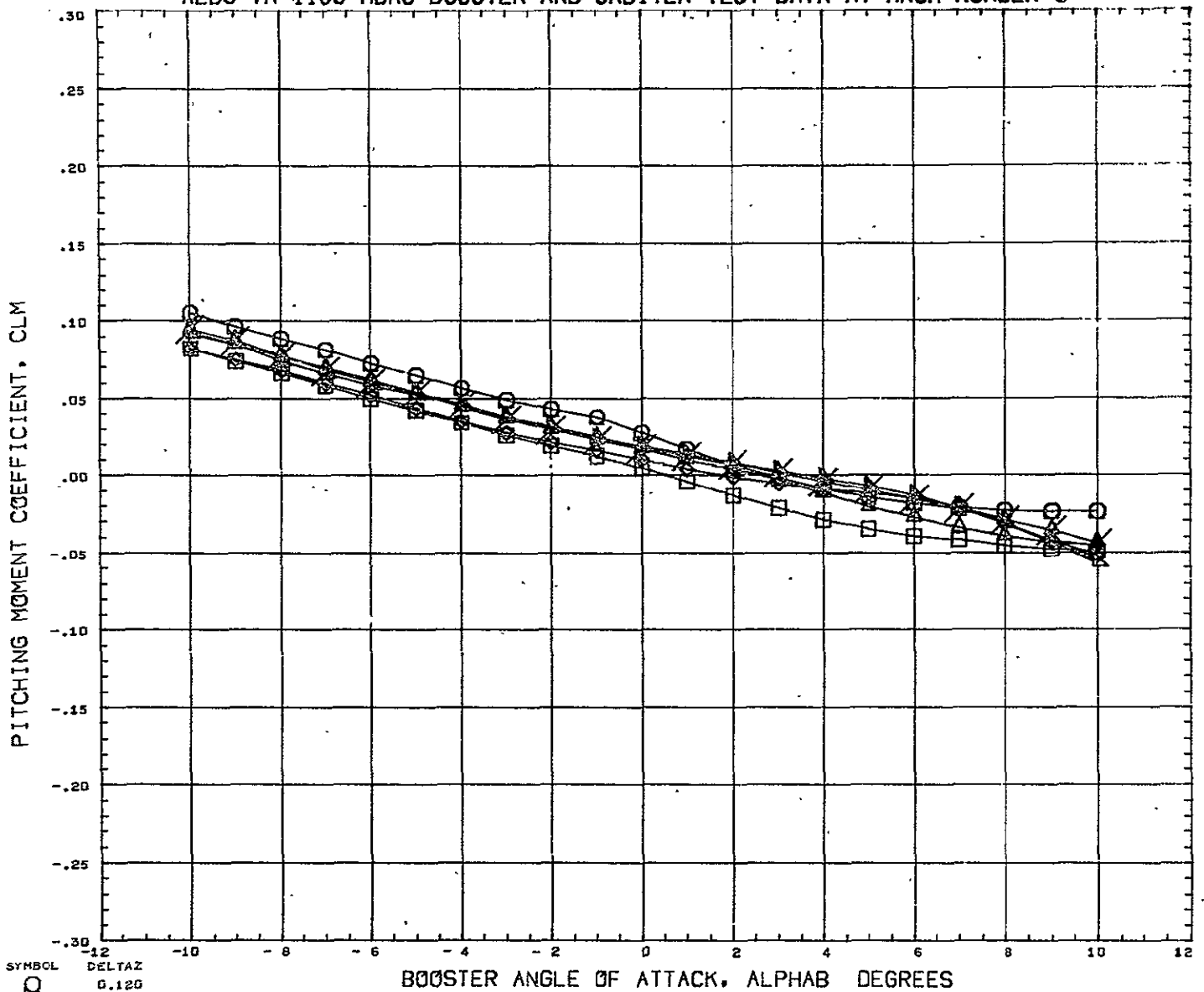

SYMBOL ○ ◇ □ △ ×	DELTA Z 0.120 0.151 0.182 0.220 0.352 10.000	PARAMETRIC VALUES BSTPOW 50.000 ORBPOW 100.000 DELTAX 0.043 ALPHA1 - 4.900 MACH 5.010 ELVBST 0.000 ELVOPB 0.000 BETA 0.100	REFERENCE INFORMATION REFS 23.6890 S8 IN REFL 4.1930 IN REFB 6.5000 IN XMRP 4.9170 IN YMRP 0.0000 IN ZMRP 1.3900 IN SCALE 0.0055
---------------------------------	--	--	---

REFERENCE FILE

# AEDC VA 1163 MDAC BOOSTER AND ORBITER TEST DATA AT MACH NUMBER 5

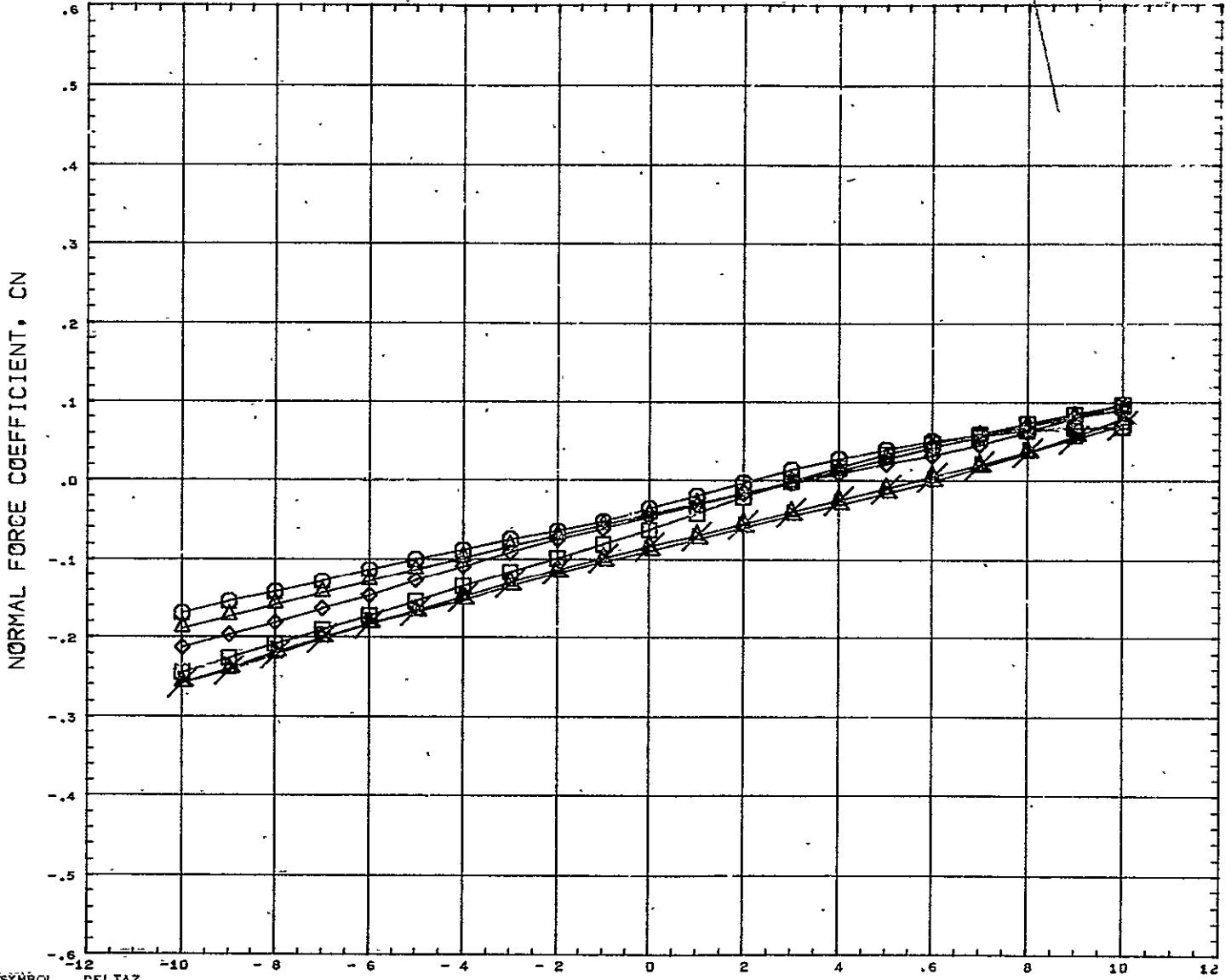

SYMBOL ○ ◇ □ △ ▽ ×	DELTAX 0.120 0.151 0.182 0.228 0.352 10.000	DELTAY 0.043 5.010 0.000	PARAMETRIC VALUES	ORBPOW 100.000 ALPHAI - 4.900 ELVBST 0.000 BETA 0.000	REFERENCE INFORMATION REFS 23.6890 SQ IN REFL 4.1930 IN REFB 6.5000 IN XMRP 4.9170 IN YMRP 0.0000 IN ZMRP 1.3900 IN SCALE 0.0055
--------------------------------------	---	-----------------------------------	-------------------	--	---

REFERENCE FILE

# AEDC VA 1163 MDAC BOOSTER AND ORBITER TEST DATA AT MACH NUMBER 5

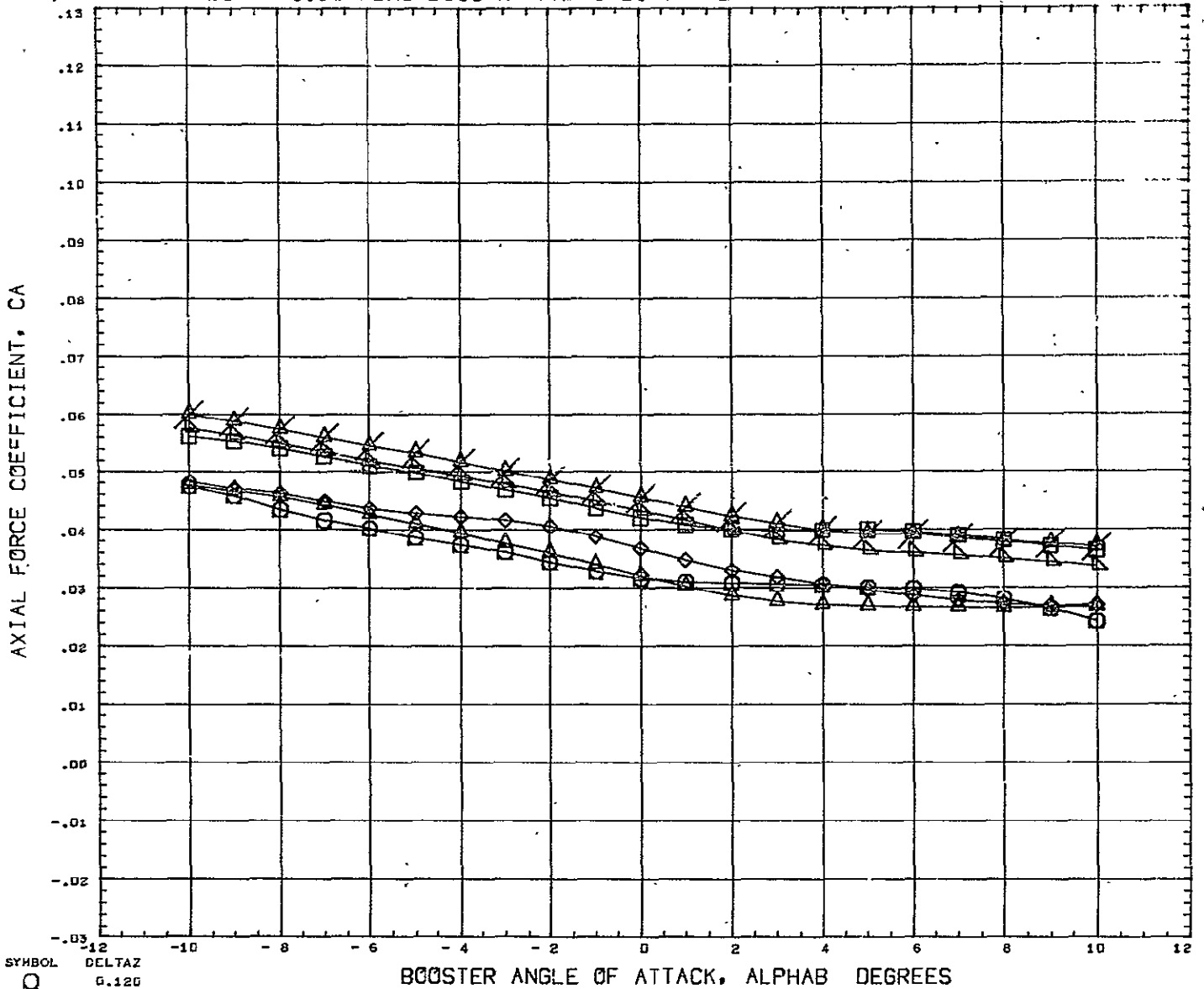

SYMBOL ○ ◇ □ △ X	DELTAZ 0.120 0.151 0.182 0.228 0.392 10.000	PARAMETRIC VALUES BSTPOW 50.000 CRBPOW 100.000 DELTAX 0.043 ALPHAI - 4.900 MACH 5.010 ELVBST 0.000 ELVORB 0.000 BETA 0.000	REFERENCE INFORMATION REFS 23.6890 SQ IN REFL 4.1930 IN REFB 6.5000 IN XNRP 4.9170 IN YNRP 0.0004 IN ZNRP 1.3900 IN SCALE 0.0059
---------------------------------	---	--	---

REFERENCE FILE

AEDC VA 1163 MDAC BOOSTER AND ORBITER TEST DATA AT MACH NUMBER 5

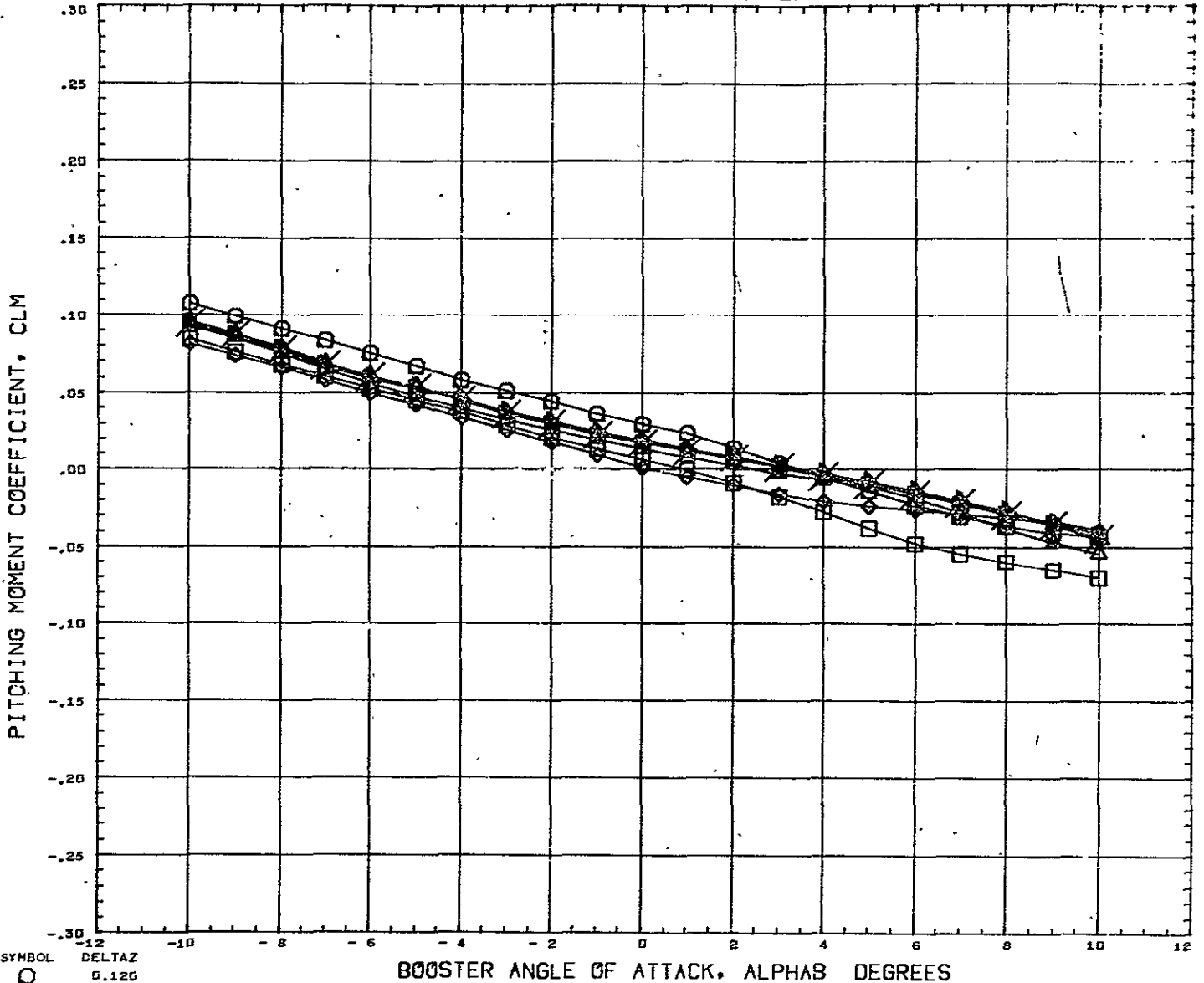

SYMBOL	DELTA Z	PARAMETRIC VALUES				REFERENCE INFORMATION		
○	0.120	BSTFOW	50.000	ORBPOW	100.000	REFS	23.6890	SQ IN
◇	0.151	DELTA X	0.105	ALPHA I	4.900	REFL	4.1930	IN
□	0.182	MACH	5.010	ELVBST	0.000	REFB	6.5000	IN
△	0.228	ELVORB	0.000	BETA	0.000	XMRP	4.9170	IN
◇	0.352					YMRP	6.0000	IN
△	0.599					ZMRP	1.3900	IN
◇	10.000					SCALE	0.0055	
		REFERENCE FILE						



# AEDC VA 1163 MDAC BOOSTER AND ORBITER TEST DATA AT MACH NUMBER 5

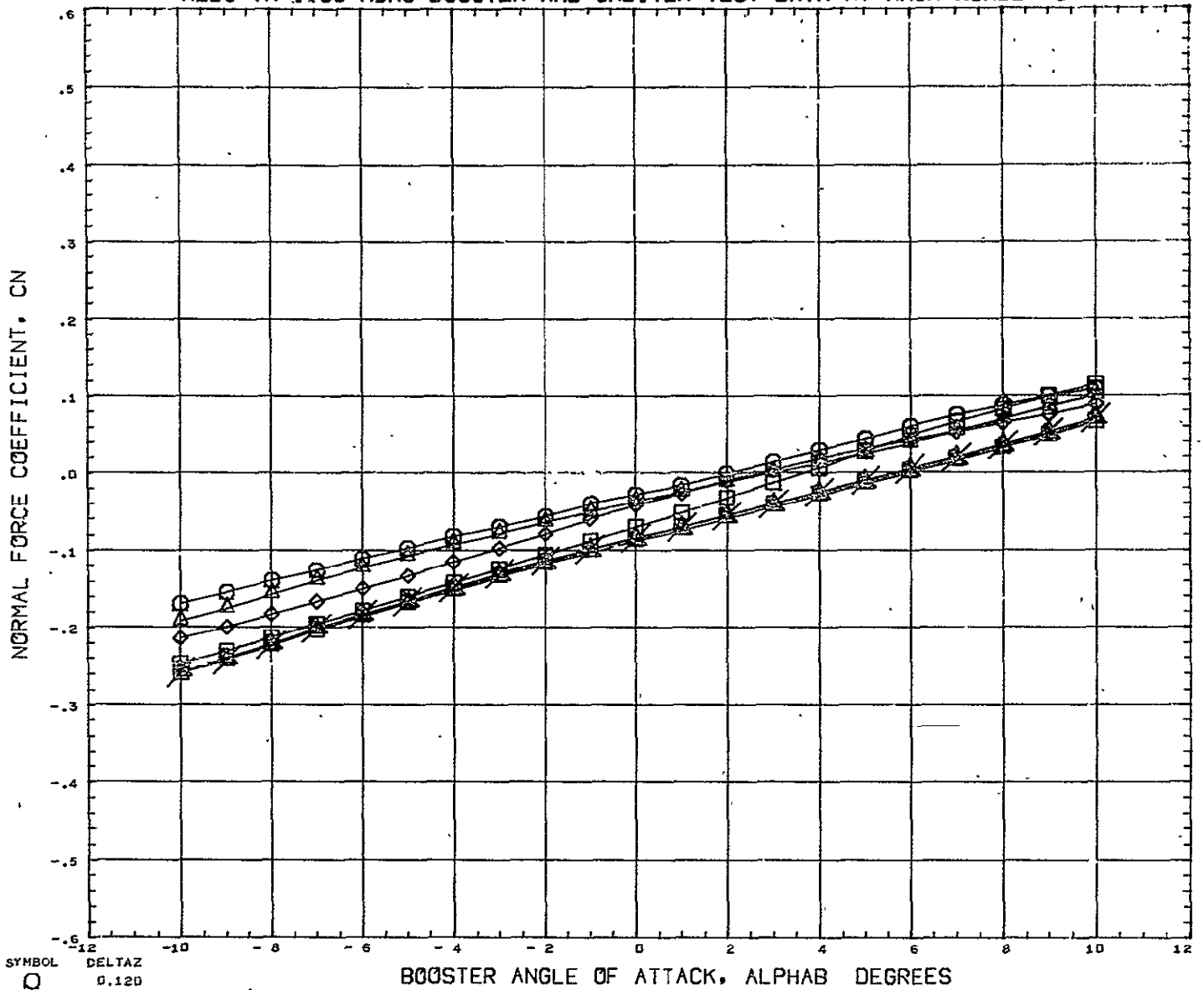

SYMBOL	DELTA Z	PARAMETRIC VALUES				REFERENCE INFORMATION		
○	0.120	BSTPOW	50.000	ORBPOW	100.000	REFS	23.6890	SQ IN
△	0.151	DELTA X	0.105	ALPHA I	-4.900	REFL	4.1930	IN
◇	0.182	MACH	5.010	ELVBST	0.000	REFB	6.5000	IN
□	0.228	ELVORB	0.000	BETA	0.000	XMRP	4.9170	IN
×	0.352					YMRP	0.0000	IN
◇	0.599					ZMRP	1.3900	IN
○	10.000					SCALE	0.0055	

REFERENCE FILE

# AEDC VA 1163 MDAC BOOSTER AND ORBITER TEST DATA AT MACH NUMBER 5

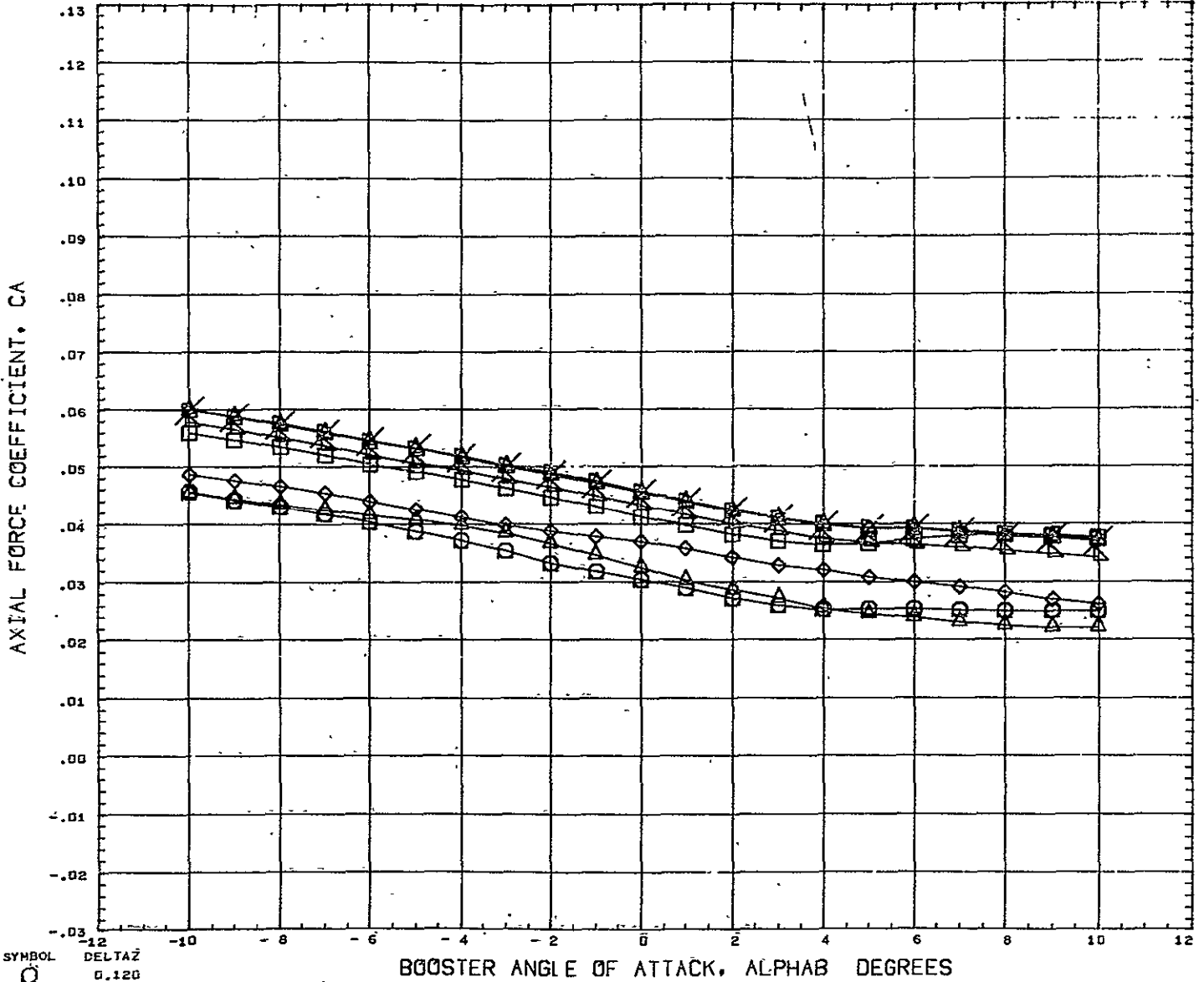

SYMBOL ○ ◇ □ △ × ●	DELTA Z 0.120 0.151 0.182 0.228 0.352 0.599 10.000	PARAMETRIC VALUES BSTPOW 50.000 ORBPOW 100.000 DELTAX 0.105 ALPHAI - 4.900 MACH 5.010 LLVBST 0.000 ELVORB 0.000 BETA 0.000	REFERENCE INFORMATION REFS 23.6890 SQ IN REFL 4.1930 IN REFB 6.5000 IN XMRP 4.9170 IN YMRP 0.0000 IN ZMRP 1.3905 IN SCALE 0.0055
--------------------------------------	---	--	---

REFERENCE FILE

# AEDC VA 1163 MDAC BOOSTER AND ORBITER TEST DATA AT MACH NUMBER 5

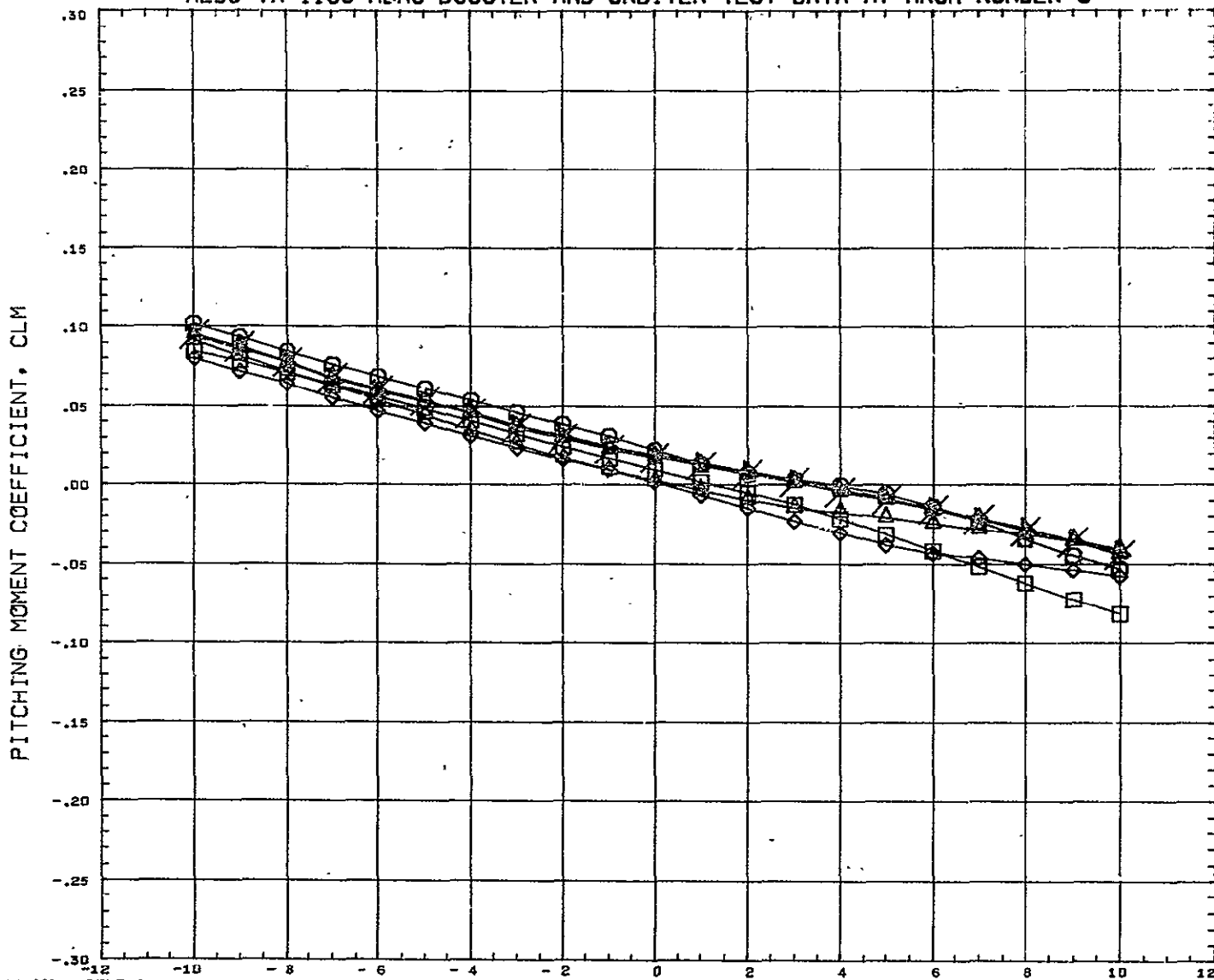

SYMBOL ○ ◇ □ △ × ▽	DELTAZ 0.120 0.151 0.182 0.228 0.352 10.000	PARAMETRIC VALUES BSTPOW 50.000 ORBPOW 100.000 JELTAX 0.167 ALPHAI - 4.900 MACH 5.010 ELVBST 0.000 ELVORB 0.000 BETA 0.000	REFERENCE INFORMATION REFS 23.6890 SQ IN REFL 4.1930 IN REFB 6.5000 IN XMRP 4.9170 IN YMRP 0.0000 IN ZMRP 1.3900 IN SCALE 0.0055
--------------------------------------	---	--	---

REFERENCE FILE

# AEDC VA 1163 MDAC BOOSTER AND ORBITER TEST DATA AT MACH NUMBER 5

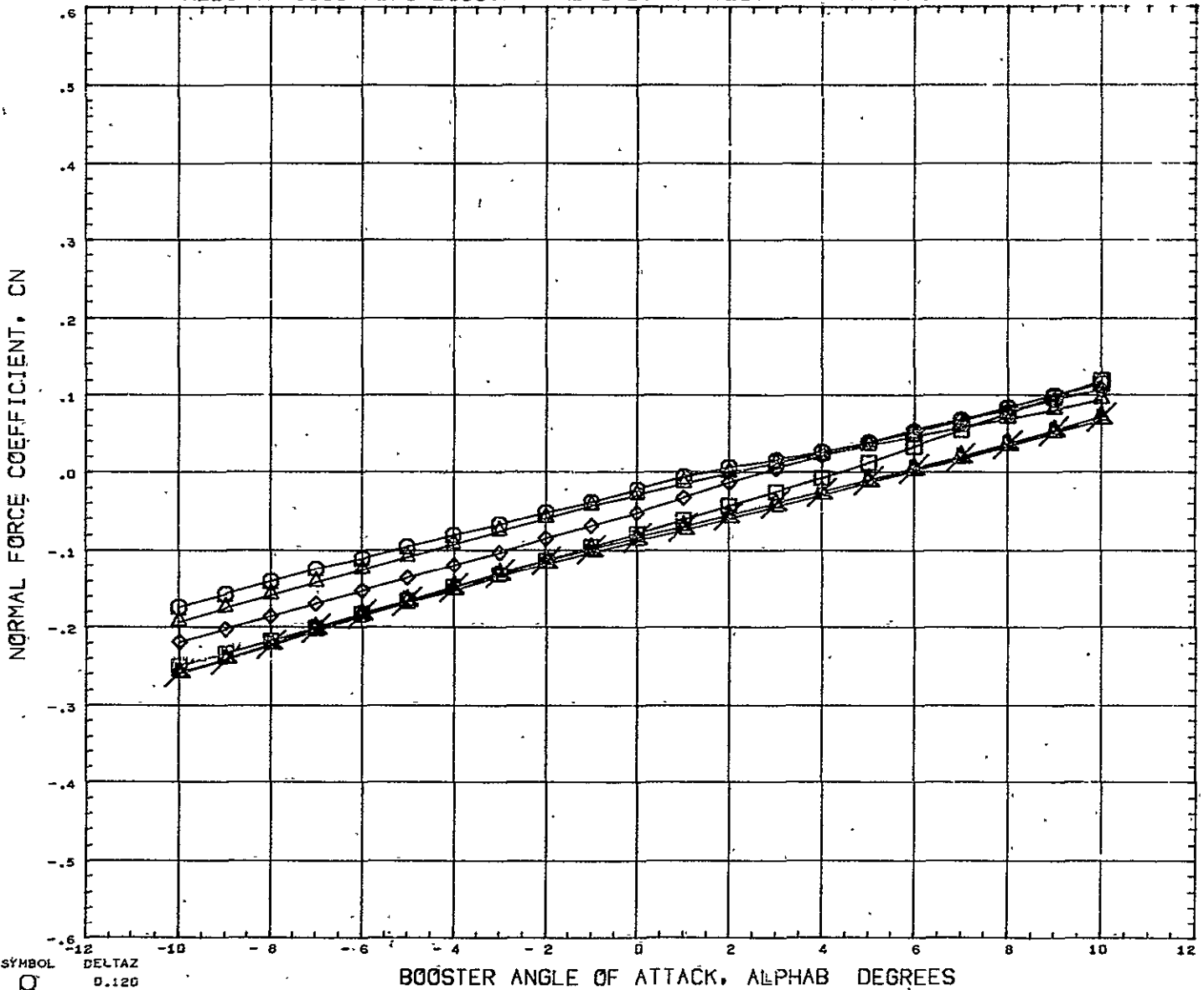

SYMBOL ○ ◇ □ △	DELTAZ 0.120 0.151 0.182 0.228 0.352 10.000	PARAMETRIC VALUES BSTFOW 50.000 ORBFOW 100.000 JELTAX 0.167 ALPHAI - 4.900 MACH 5.010 ELVBST 0.000 ELVORB 0.000 BETA 0.000	REFERENCE INFORMATION REFS 23.6890 SQ IN REFL 4.1930 IN REFB 6.5050 IN XMRP 4.9170 IN YMRP 0.0000 IN ZMRP 1.3900 IN SCALE 0.0055
----------------------------	---	--	---

REFERENCE FILE

# AEDC VA 1163 MDAC BOOSTER AND ORBITER TEST DATA AT MACH NUMBER 5

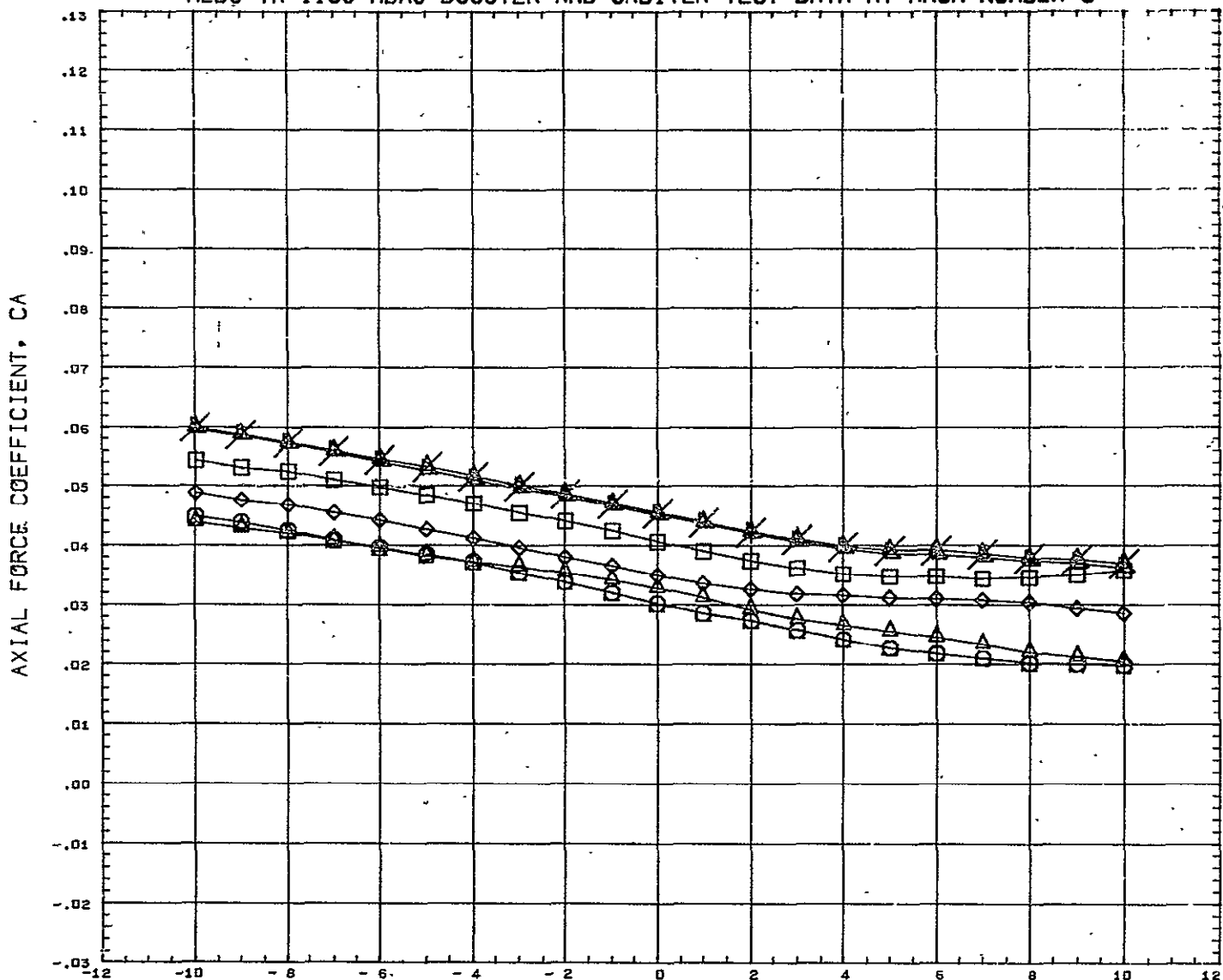

SYMBOL □ ◇ △ ▽ ○ ×	DELTAZ 0.120 0.151 0.182 0.228 0.352 10.000	PARAMETRIC VALUES BSTPOW 50.000 ORBPOW 100.000 DELTAX 0.167 ALPHAI - 4.900 MACH 5.010 ELVBST 0.000 ELVORB 0.000 BETA 0.000	REFERENCE INFORMATION REFS 23.6890 SQ IN REFL 4.1930 IN REFB 6.5000 IN XMRF 4.9170 IN YMRF 0.0000 IN ZMRF 1.3900 IN SCALE 0.0055
--------------------------------------	---	--	---

REFERENCE FILE

# AEDC VA 1163 MDAC BOOSTER AND ORBITER TEST DATA AT MACH NUMBER 5

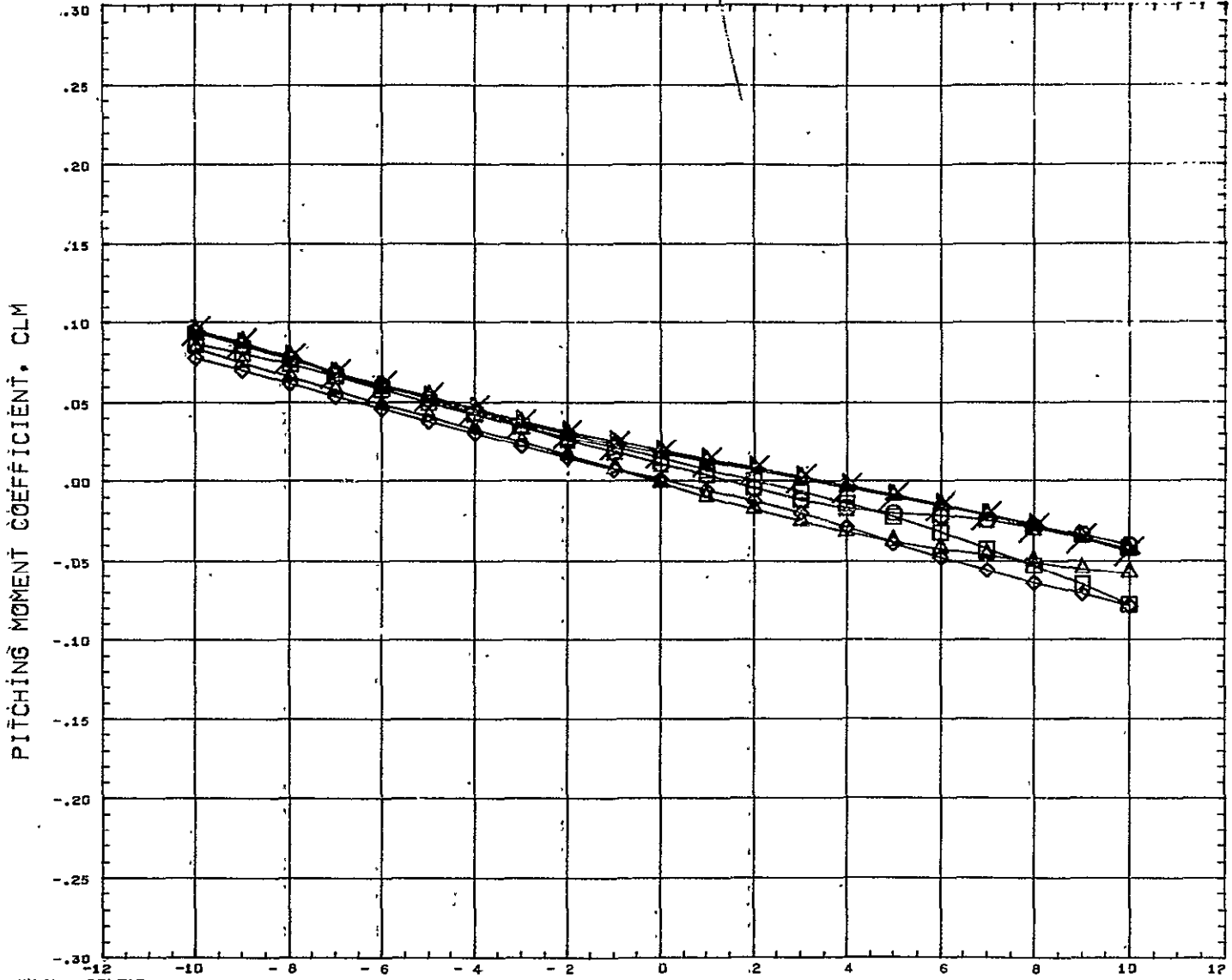

SYMBOL ○ □ △ ◇ ×	DELTAZ 0.120 0.151 0.182 0.228 0.352 10.000	PARAMETRIC VALUES BSTPOW 50.000 ORBPOW 100.000 DELTAX 0.228 ALPHAI - 4.900 MACH 5.010 ELVBST 0.000 ELVORB 0.000 BETA 0.000	REFERENCE INFORMATION REFS 23.6890 SQ IN REFL 4.1930 IN REFB 6.5000 IN XMRF 4.6170 IN YMRF 0.0000 IN ZMRF 1.3900 IN SCALE 0.0055
---------------------------------	---	--	---

REFERENCE FILE

# AEDC VA 1163 MDAC BOOSTER AND ORBITER TEST DATA AT MACH NUMBER 5

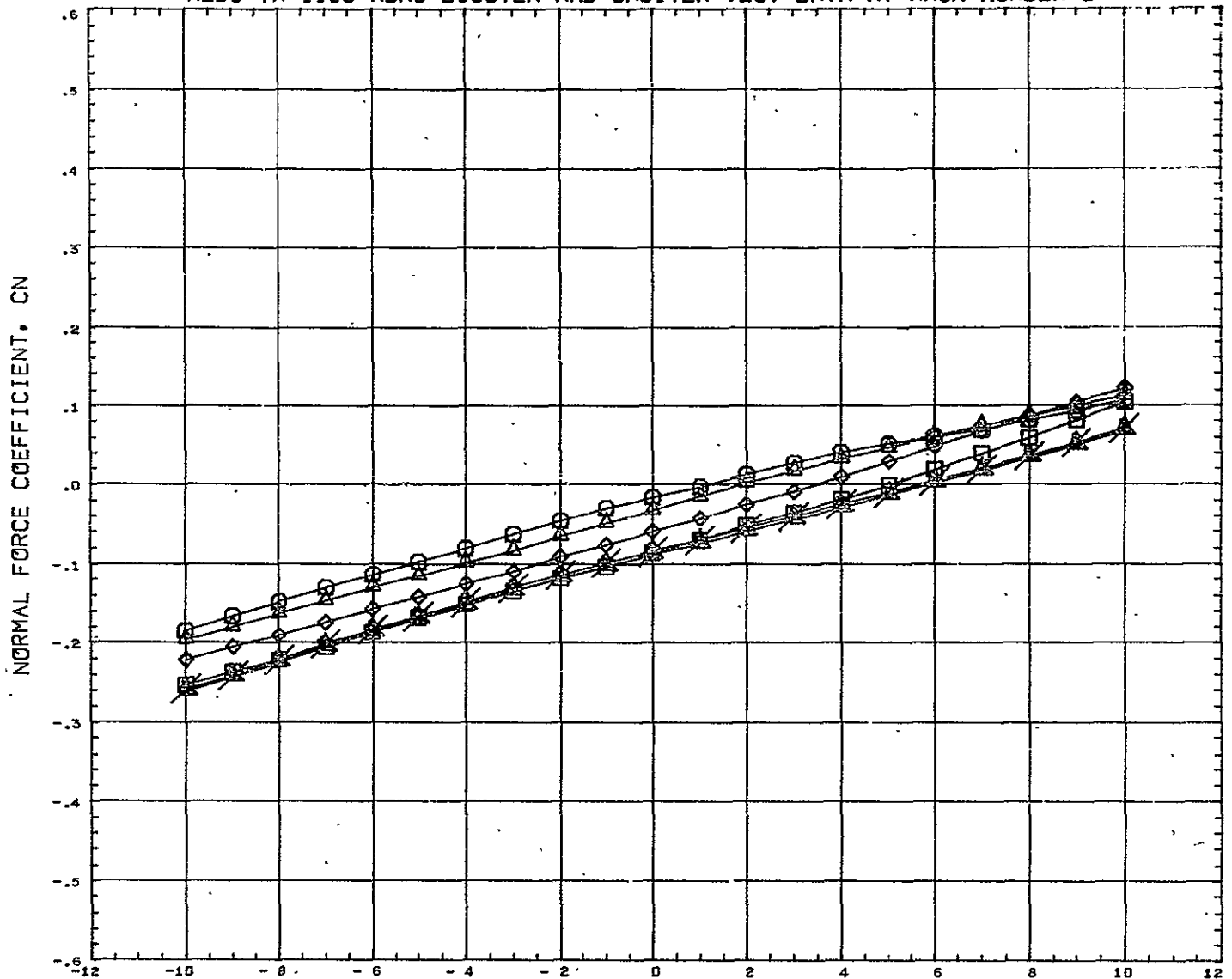

SYMBOL ○ ◇ □ △	DELTAZ 0.120 0.151 0.182 0.228 0.352 10.000	PARAMETRIC VALUES BSTPOW 50.000 ORBPOW 100.000 DELTAX 0.228 ALPHAI - 4.900 MACH 5.010 ELVBST 0.000 ELVORB 0.000 BETA 0.000	REFERENCE INFORMATION REFS 23.6890 SQ IN REFL 4.1930 IN REFB 6.5000 IN XMRP 4.5170 IN YMRP 0.0000 IN ZMRP 1.3900 IN SCALE 0.0055
----------------------------	---	--	---

REFERENCE FILE

# AEDC VA 1163 MDAC BOOSTER AND ORBITER TEST DATA AT MACH NUMBER 5

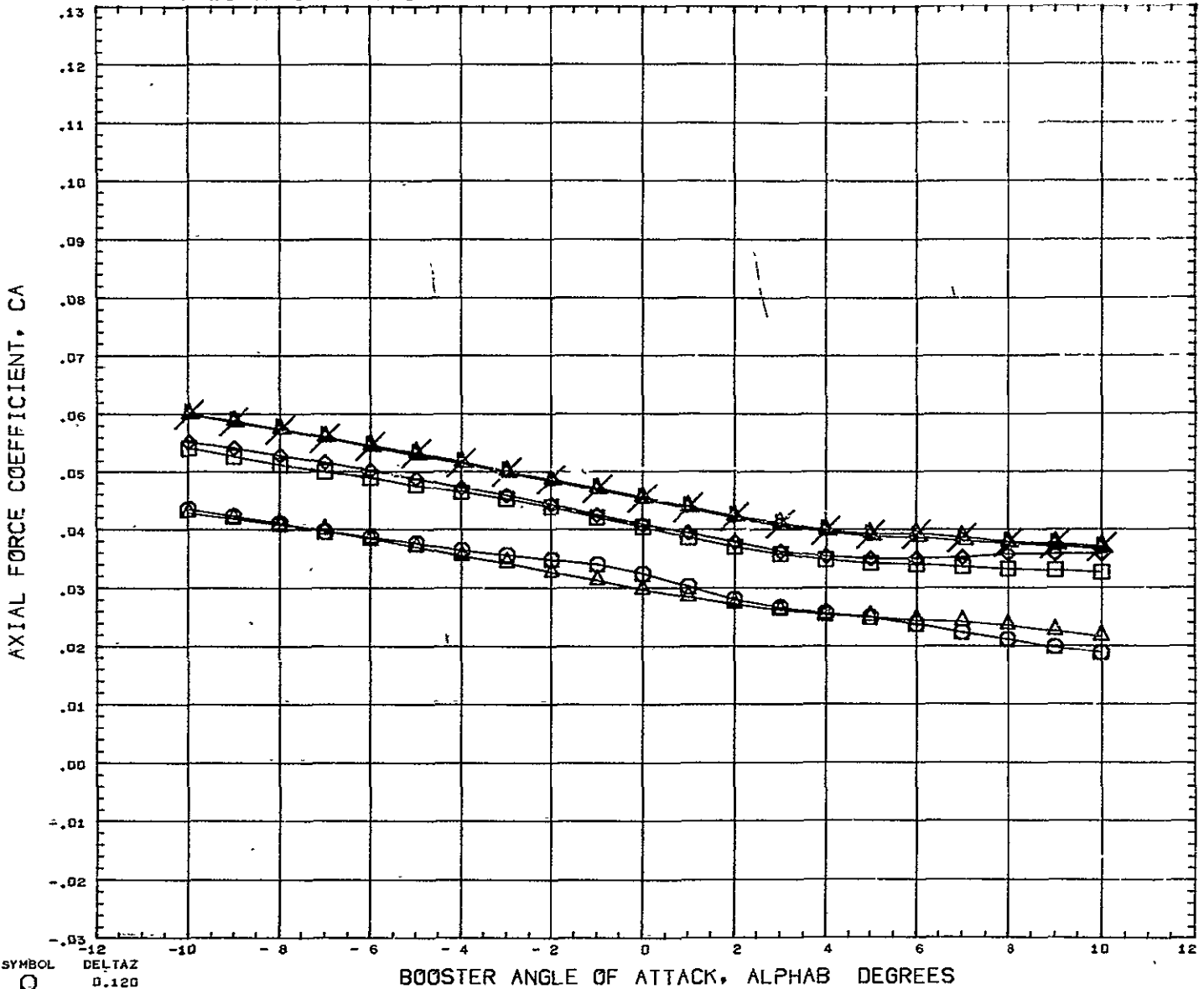

SYMBOL ○ ◇ □ △ ×	DELTA Z 0.120 0.151 0.182 0.228 0.352 10.506	PARAMETRIC VALUES BSTFOW 50.000 ORBPOW 100.000 JELTAX 0.228 ALPHAI - 4.900 MACH 5.010 CLVBST 0.000 ELVORB 0.000 BETA 0.000	REFERENCE INFORMATION REFS 23.6890 SQ IN REFL 4.1930 IN REFB 6.5000 IN XMRP 4.9176 IN YMRP 0.0000 IN ZMRP 1.3900 IN SCALE 0.0055
---------------------------------	--	--	---

REFERENCE FILE



# AEDC VA 1163 MDAC BOOSTER AND ORBITER TEST DATA AT MACH NUMBER 5

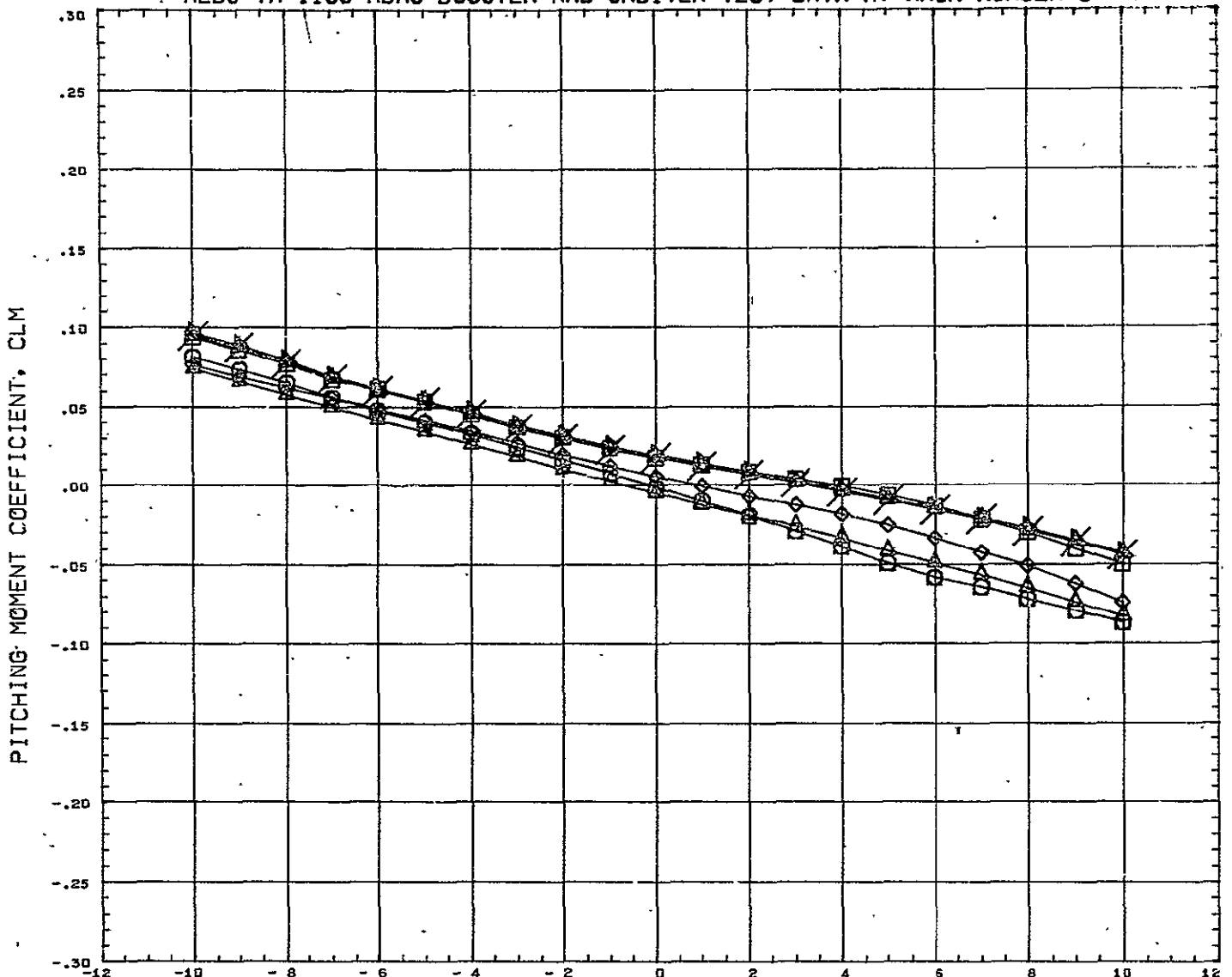

SYMBOL ○ □ △ ◇ ×	DELTA Z 0.120 0.151 0.182 0.228 0.352 10.000	PARAMETRIC VALUES BSTPOW 50.000 ORBPOW 100.000 DELTAX 0.352 ALPHAI - 4.900 MACH 5.010 ELVBST 0.000 ELVORB 0.000 BETA 0.000	REFERENCE INFORMATION REFS 23.6890 SQ IN REFL 4.1930 IN REFB 6.5000 IN XMRP 4.9170 IN YMRP 0.0000 IN ZMRP 1.3900 IN SCALE 0.0055
---------------------------------	--	--	---

REFERENCE FILE

# AEDC VA 1163 MDAC BOOSTER AND ORBITER TEST DATA AT MACH NUMBER 5

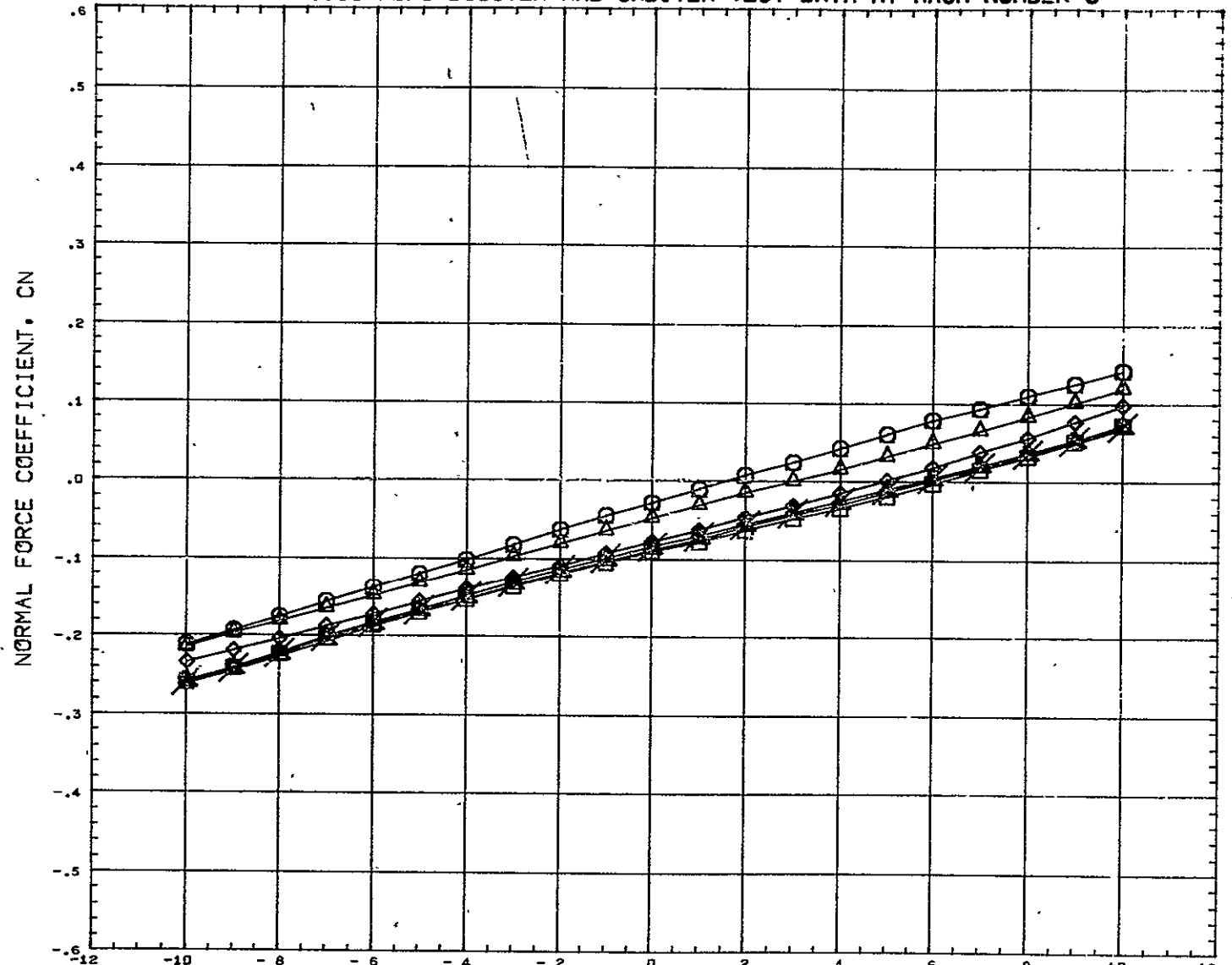

SYMBOL ○ △ □ ◇ ×	DELTA Z 0.120 0.151 0.182 0.228 0.352 10.000	PARAMETRIC VALUES BSTFOW 50.000 ORBPOW 100.000 DELTAX 0.352 ALPHAI 4.900 MACH 5.010 ELVBST 0.000 ELVORB 0.000 BETA 0.000	REFERENCE INFORMATION REFS 23.6890 SQ IN REFL 4.1930 IN REFB 6.5000 IN XMRP 4.9170 IN YMRP 0.0000 IN ZMRP 1.3900 IN SCALE 0.0055
---------------------------------	--	--	---

151 REFERENCE FILE

# AEDC VA 1163 MDAC BOOSTER AND ORBITER TEST DATA AT MACH NUMBER 5

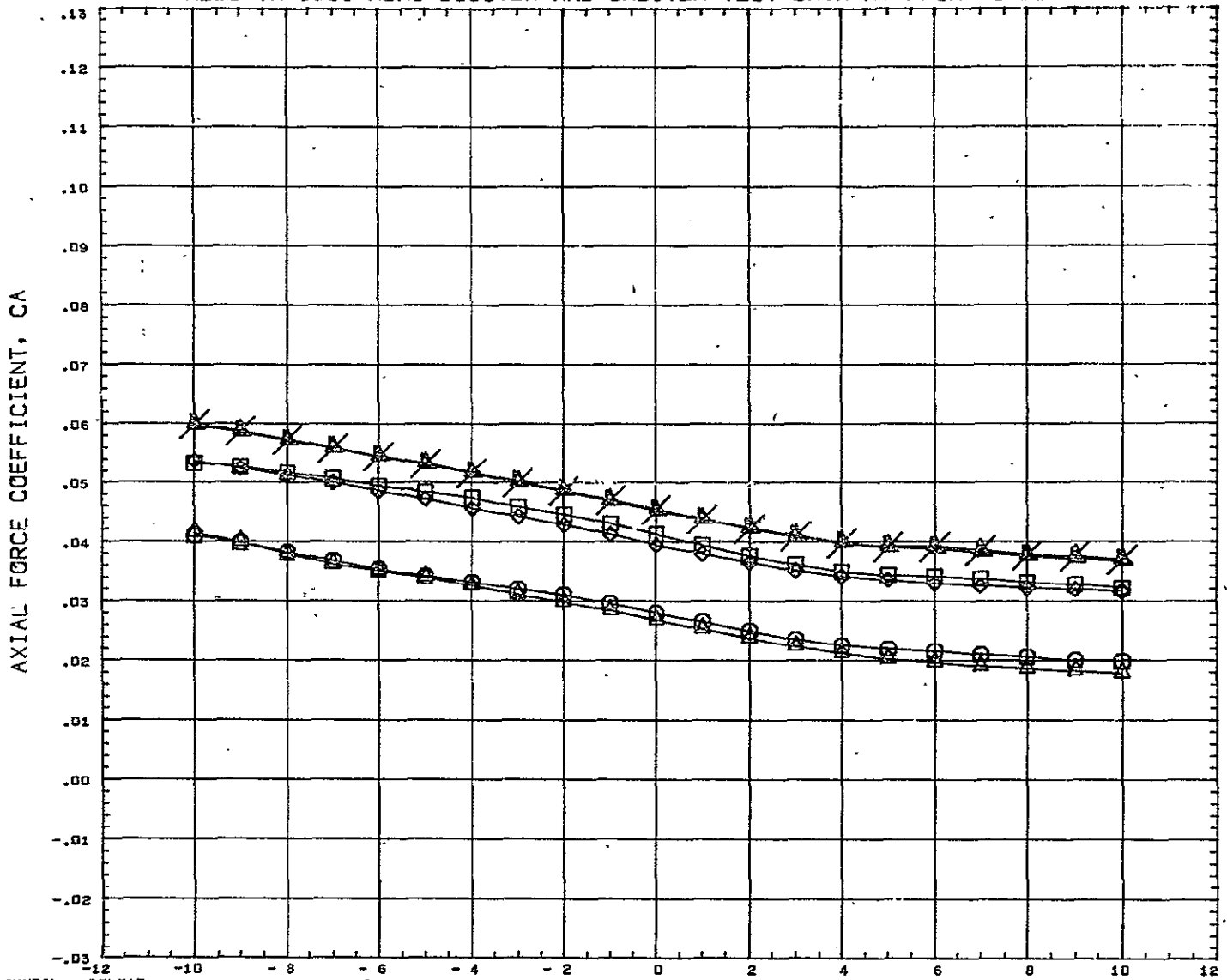

SYMBOL ○ △ ◇ □ ×	DELTAZ 0.120 0.151 0.182 0.228 0.352 10.000	PARAMETRIC VALUES BSTPOW 50.000 ORBPOW 100.000 DELTAX 0.352 ALPHAI - 4.900 MACH 5.010 ELVBST 0.000 ELVORB 0.000 BETA 0.000	REFERENCE INFORMATION REFS 23.6890 SQ IN REFL 4.1930 IN REFB 6.5000 IN XMRP 4.9170 IN YMRP 0.0000 IN ZMRP 1.3900 IN SCALE 0.0055
---------------------------------	---	--	---

REFERENCE FILE



# AEDC VA 1163 MDAC BOOSTER AND ORBITER TEST DATA AT MACH NUMBER 5

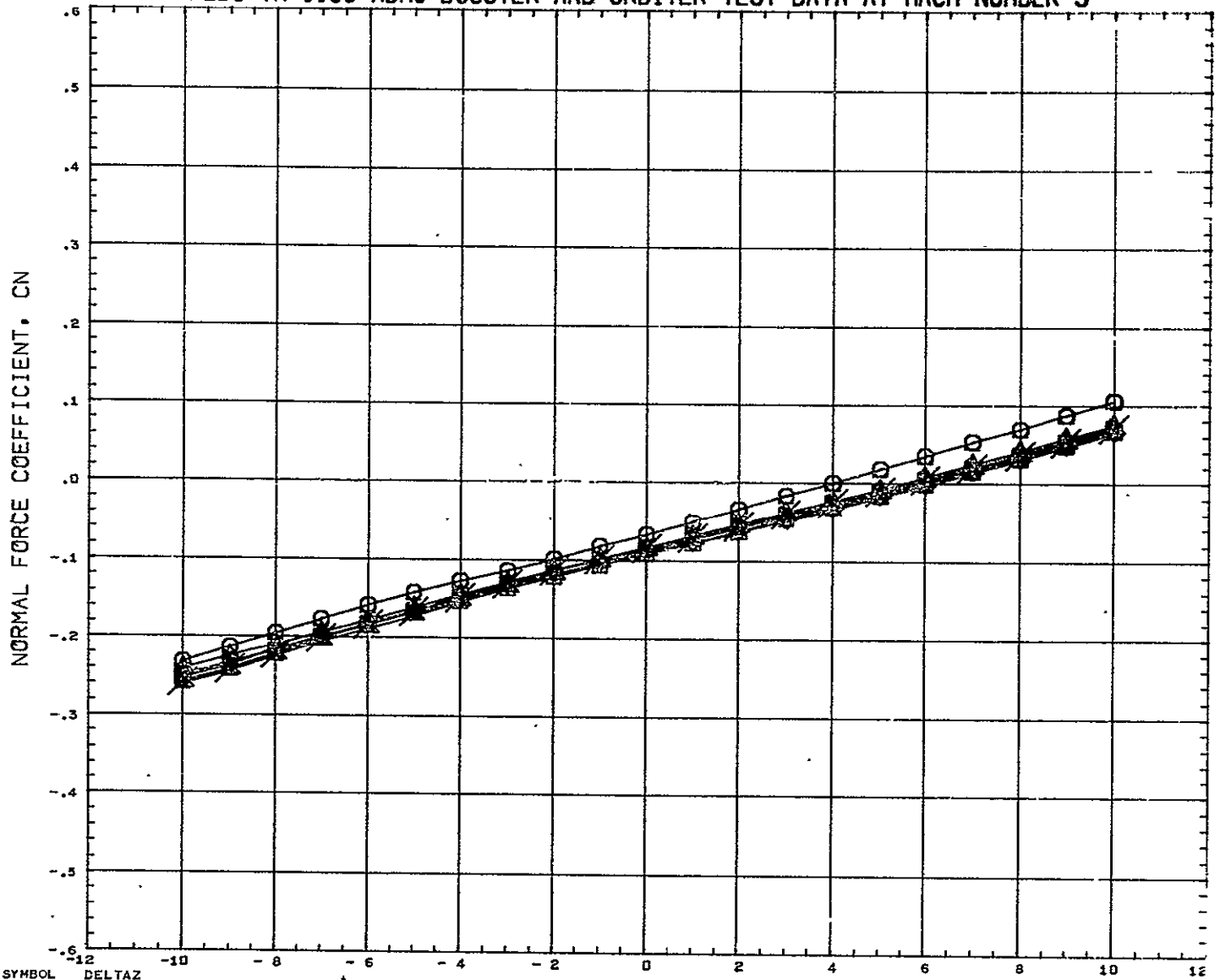

SYMBOL ○ ◇ △ □ × * + .	DELTAX 0.120 0.151 0.182 0.228 0.352 0.599 10.000	PARAMETRIC VALUES BSTPOW 50.000 ORBPOW 100.000 DELTAX 0.522 ALPHAI - 4.900 MACH 5.010 ELVBST 0.000 ELVORB 0.000 BETA 0.000	REFERENCE INFORMATION REFS 23.6890 SQ IN REFL 4.1930 IN REFB 6.5000 IN XMRF 4.9170 IN YMRF 0.0000 IN ZMRF 1.3900 IN SCALE 0.0055	BOOSTER ANGLE OF ATTACK, ALPHAB DEGREES
REFERENCE FILE				

# AEDC VA 1163 MDAC BOOSTER AND ORBITER TEST DATA AT MACH NUMBER 5

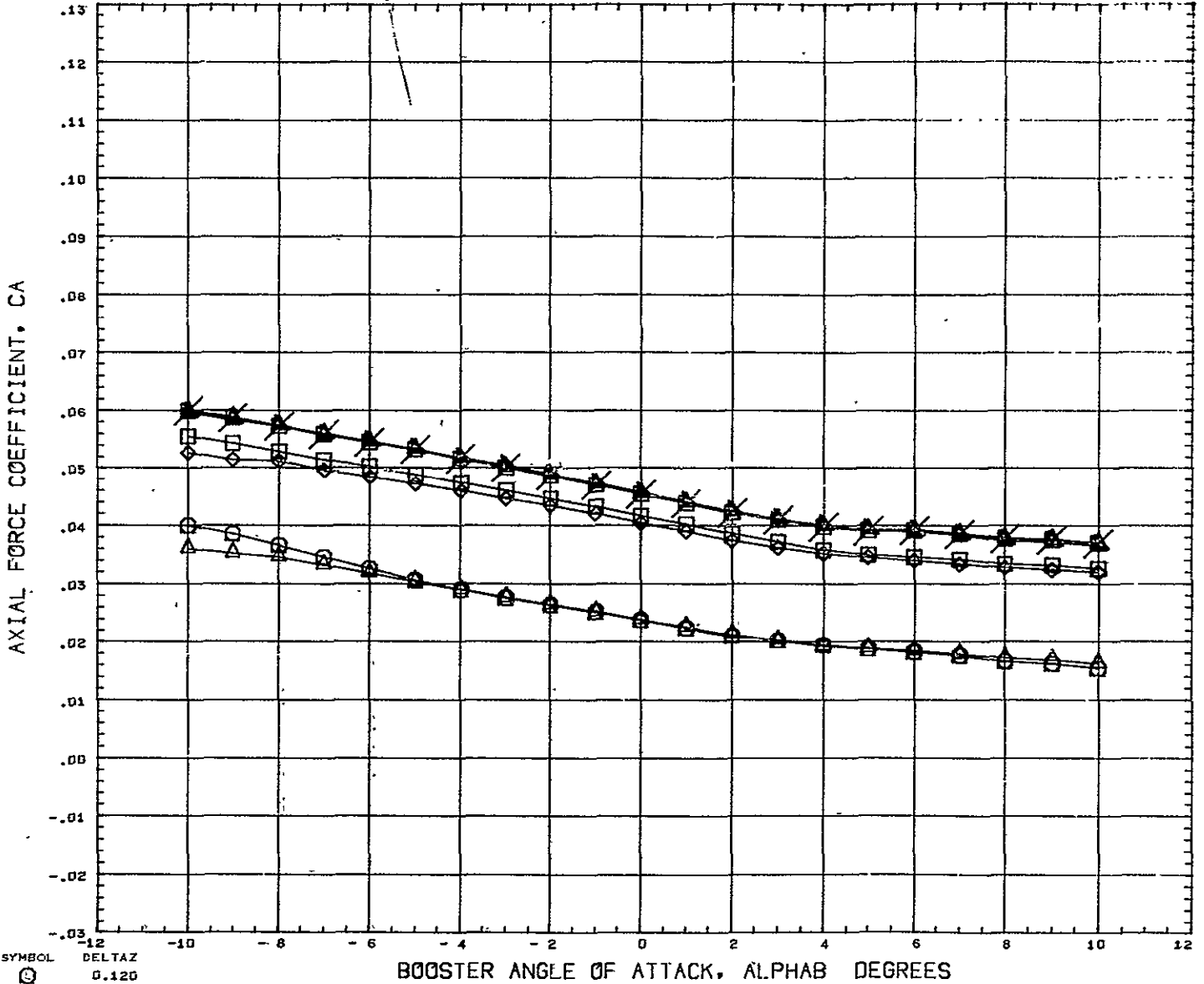

SYMBOL ○ ◇ □ △ ▲ ×	DELTAX 0.120 0.151 0.182 0.228 0.352 0.599 10.000	PARAMETRIC VALUES BSTPOW 50.000 ORBPOW 100.000 DELTAX 0.522 ALPHAI - 4.900 MACH 5.010 ELVBST 0.000 ELVORB 0.000 BETA 0.000	REFERENCE INFORMATION REFS 23.6890 SQ IN REFL 4.1930 IN REFB 6.5000 IN XMRF 4.9170 IN YMRF 0.0000 IN ZMRF 1.3900 IN SCALE 0.0055
--------------------------------------	--	--	---

REFERENCE FILE

# AEDC VA 1163 MDAC BOOSTER AND ORBITER TEST DATA AT MACH NUMBER 5

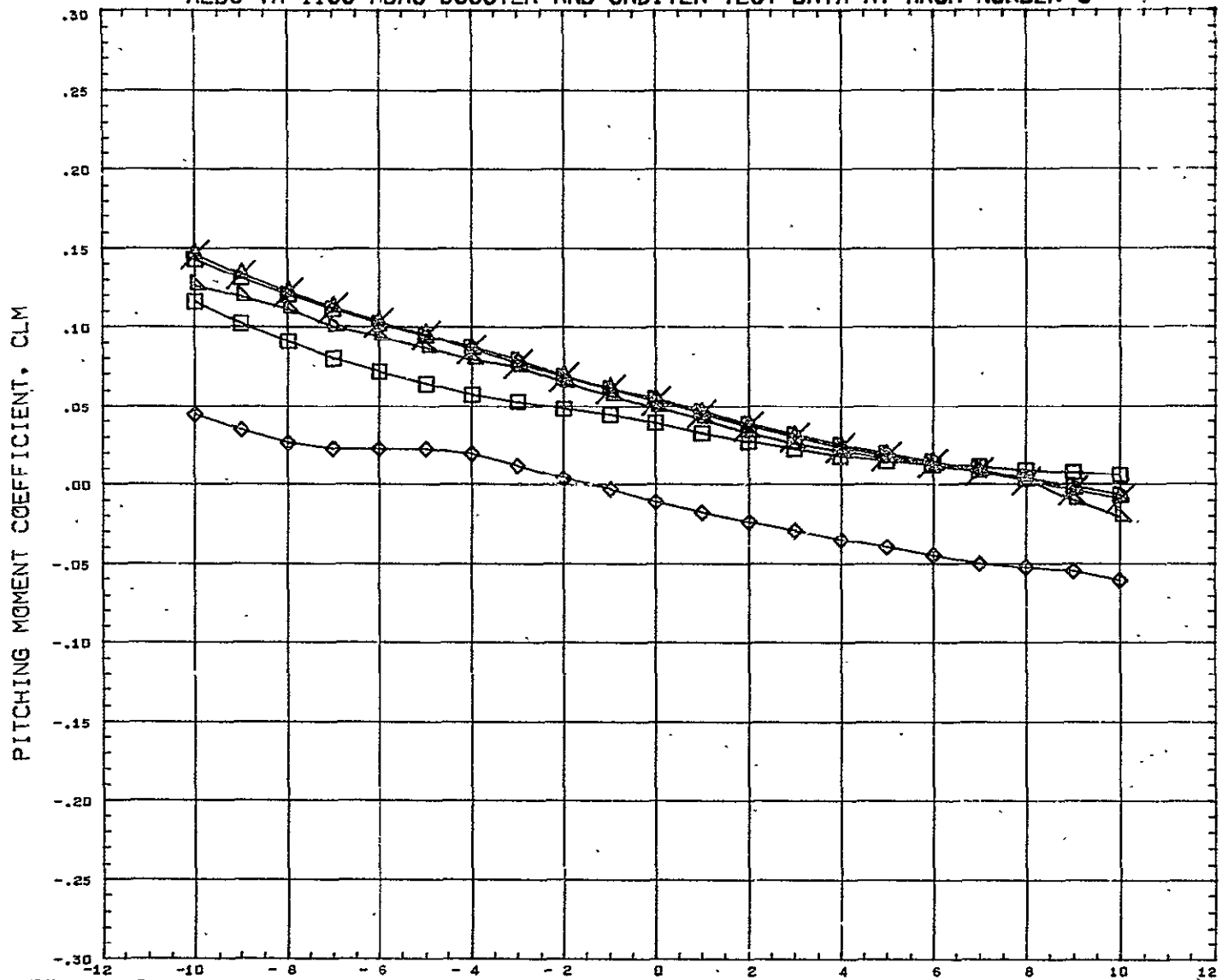

SYMBOL ◇ □ △ ×	DELTAX 0.182 0.228 0.352 0.599 10.000 ELVORB 0.000	<b>PARAMETRIC VALUES</b> BSTPOW 50.000 ORBPOW 100.000 DELTAX - 0.391 ALPHAI - 10.000 MACH 5.010 ELVBST 0.000 BETA 0.000	<b>REFERENCE INFORMATION</b> REFS 23.6890 SQ IN REFL 4.1930 IN REFB 6.5000 IN XNRF 4.9170 IN YNRF 0.0000 IN ZNRF 1.3900 IN SCALE 0.0055
REFERENCE FILE			

# AEDC VA 1163 MDAC BOOSTER AND ORBITER TEST DATA AT MACH NUMBER 5

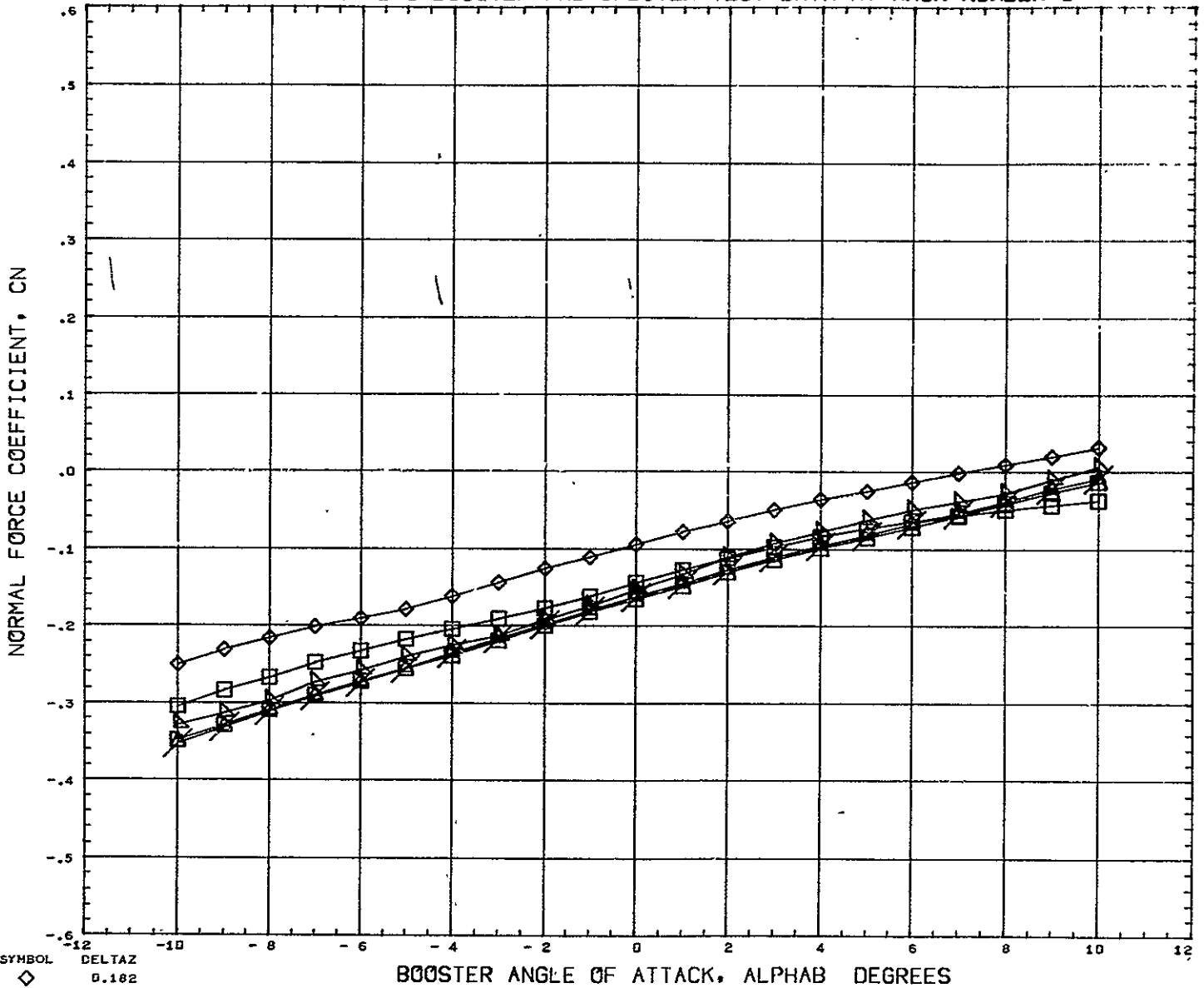

SYMBOL ◇ □ △ ×	DELTAZ 0.182 0.228 0.352 0.599 10.000	<table border="0" style="width: 100%;"> <tr> <th colspan="4" style="text-align: center;">PARAMETRIC VALUES</th> </tr> <tr> <td>BSTPOW</td><td>50.000</td><td>ORBPOW</td><td>100.000</td> </tr> <tr> <td>DELTAZ</td><td>- 0.391</td><td>ALPHA1</td><td>- 10.000</td> </tr> <tr> <td>MACH</td><td>5.010</td><td>ELVBST</td><td>0.000</td> </tr> <tr> <td>ELVORB</td><td>0.000</td><td>BETA</td><td>0.000</td> </tr> </table>	PARAMETRIC VALUES				BSTPOW	50.000	ORBPOW	100.000	DELTAZ	- 0.391	ALPHA1	- 10.000	MACH	5.010	ELVBST	0.000	ELVORB	0.000	BETA	0.000	<table border="0" style="width: 100%;"> <tr> <th colspan="3" style="text-align: center;">REFERENCE INFORMATION</th> </tr> <tr> <td>REFS</td><td>23.6890</td><td>SQ IN</td> </tr> <tr> <td>REFL</td><td>4.1930</td><td>IN</td> </tr> <tr> <td>REFB</td><td>6.5000</td><td>IN</td> </tr> <tr> <td>XMRP</td><td>4.9170</td><td>IN</td> </tr> <tr> <td>YMRP</td><td>0.0000</td><td>IN</td> </tr> <tr> <td>ZMRP</td><td>1.3900</td><td>IN</td> </tr> <tr> <td>SCALE</td><td>0.0055</td><td></td> </tr> </table>	REFERENCE INFORMATION			REFS	23.6890	SQ IN	REFL	4.1930	IN	REFB	6.5000	IN	XMRP	4.9170	IN	YMRP	0.0000	IN	ZMRP	1.3900	IN	SCALE	0.0055	
PARAMETRIC VALUES																																															
BSTPOW	50.000	ORBPOW	100.000																																												
DELTAZ	- 0.391	ALPHA1	- 10.000																																												
MACH	5.010	ELVBST	0.000																																												
ELVORB	0.000	BETA	0.000																																												
REFERENCE INFORMATION																																															
REFS	23.6890	SQ IN																																													
REFL	4.1930	IN																																													
REFB	6.5000	IN																																													
XMRP	4.9170	IN																																													
YMRP	0.0000	IN																																													
ZMRP	1.3900	IN																																													
SCALE	0.0055																																														
REFERENCE FILE																																															



# AEDC VA 1163 MDAC BOOSTER AND ORBITER TEST DATA AT MACH NUMBER 5

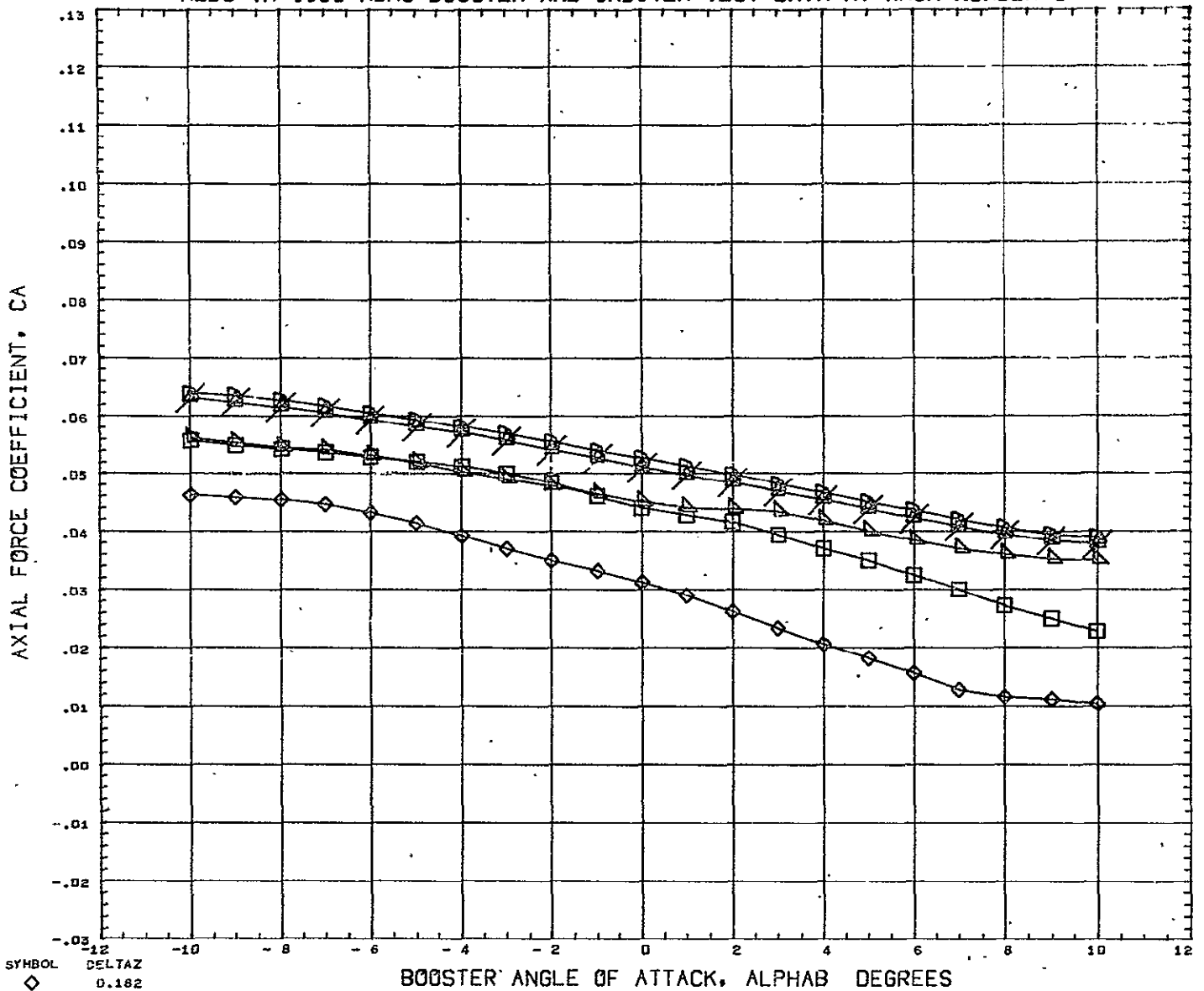

SYMBOL ◇ □ △ ×	DELTAX 0.182 0.228 0.352 0.599 10.000	<b>PARAMETRIC VALUES</b> BSTFOW 50.000 ORBFOW 100.000 DELTAX - 0.391 ALPHAI - 10.000 MACH 5.010 ELVBST 0.000 ELVORB 0.000 BETA 0.000	<b>REFERENCE INFORMATION</b> REFS 23.6890 SQ IN REFL 4.1930 IN REFB 6.5000 IN XMRP 4.9170 IN YMRP 0.0000 IN ZMRP 1.3900 IN SCALE 0.0055
REFERENCE FILE			

# AEDC VA 1163 MDAC BOOSTER AND ORBITER TEST DATA AT MACH NUMBER 5

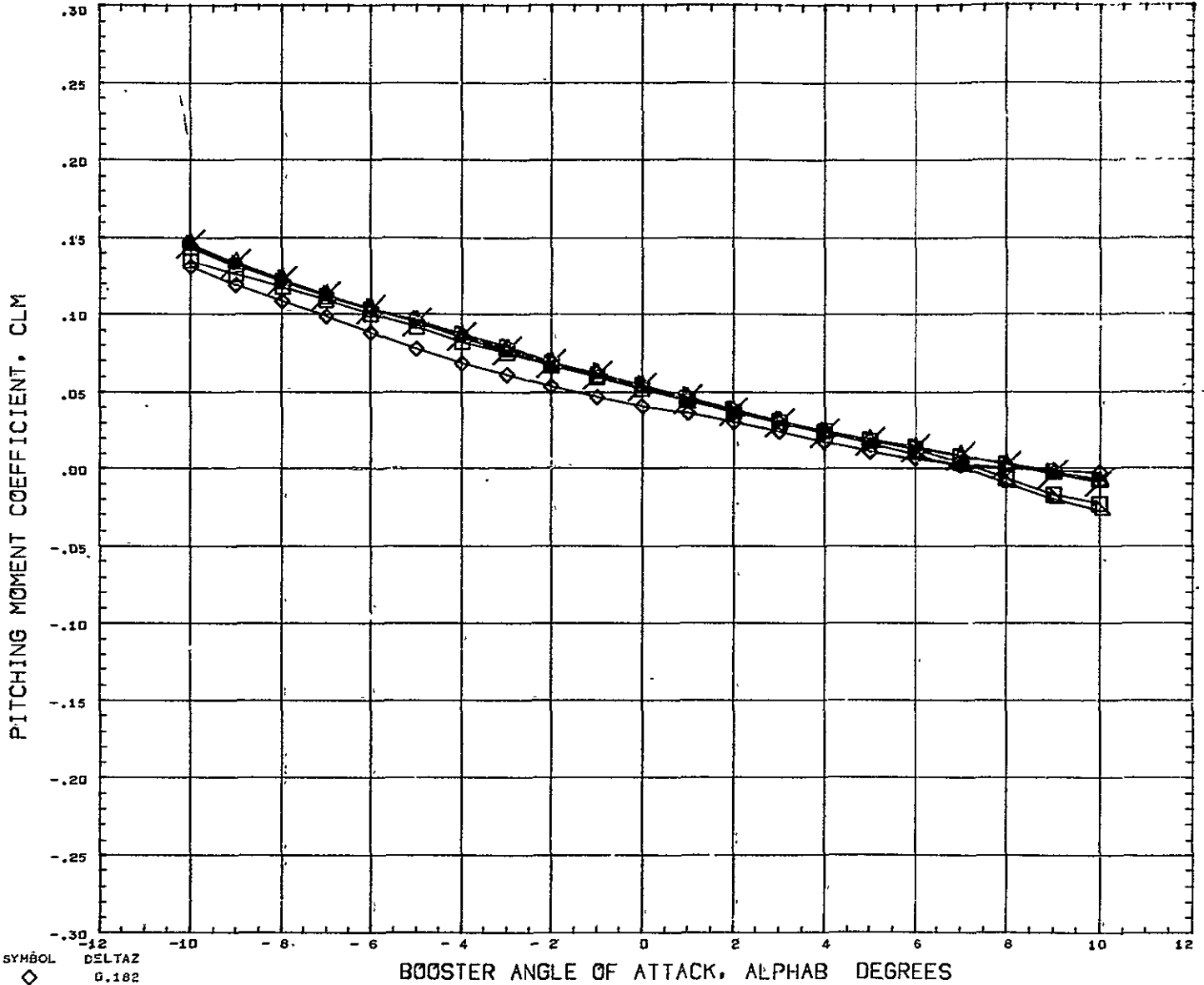

SYMBOL ◇ □ X	DELTAZ 0.182 0.229 0.352 0.599 10.000	<table border="0" style="width: 100%;"> <tr> <th colspan="4" style="text-align: center;">PARAMETRIC VALUES</th> </tr> <tr> <td>BSTFOW</td> <td>50.000</td> <td>ORBFOW</td> <td>100.000</td> </tr> <tr> <td>DELTA X</td> <td>- 0.143</td> <td>ALPHA I</td> <td>- 10.000</td> </tr> <tr> <td>MACH</td> <td>5.010</td> <td>ELVBST</td> <td>0.000</td> </tr> <tr> <td>ELVORB</td> <td>0.000</td> <td>BETA</td> <td>0.500</td> </tr> </table>	PARAMETRIC VALUES				BSTFOW	50.000	ORBFOW	100.000	DELTA X	- 0.143	ALPHA I	- 10.000	MACH	5.010	ELVBST	0.000	ELVORB	0.000	BETA	0.500	<table border="0" style="width: 100%;"> <tr> <th colspan="3" style="text-align: center;">REFERENCE INFORMATION</th> </tr> <tr> <td>REFS</td> <td>23.6890</td> <td>30 IN</td> </tr> <tr> <td>REFL</td> <td>4.1930</td> <td>IN</td> </tr> <tr> <td>REFB</td> <td>6.5000</td> <td>IN</td> </tr> <tr> <td>XMRP</td> <td>4.9170</td> <td>IN</td> </tr> <tr> <td>YMRP</td> <td>0.0000</td> <td>IN</td> </tr> <tr> <td>ZMRP</td> <td>1.3900</td> <td>IN</td> </tr> <tr> <td>SCALE</td> <td>0.0055</td> <td></td> </tr> </table>	REFERENCE INFORMATION			REFS	23.6890	30 IN	REFL	4.1930	IN	REFB	6.5000	IN	XMRP	4.9170	IN	YMRP	0.0000	IN	ZMRP	1.3900	IN	SCALE	0.0055	
PARAMETRIC VALUES																																															
BSTFOW	50.000	ORBFOW	100.000																																												
DELTA X	- 0.143	ALPHA I	- 10.000																																												
MACH	5.010	ELVBST	0.000																																												
ELVORB	0.000	BETA	0.500																																												
REFERENCE INFORMATION																																															
REFS	23.6890	30 IN																																													
REFL	4.1930	IN																																													
REFB	6.5000	IN																																													
XMRP	4.9170	IN																																													
YMRP	0.0000	IN																																													
ZMRP	1.3900	IN																																													
SCALE	0.0055																																														

REFERENCE FILE

# AEDC VA 1163 MDAC BOOSTER AND ORBITER TEST DATA AT MACH NUMBER 5

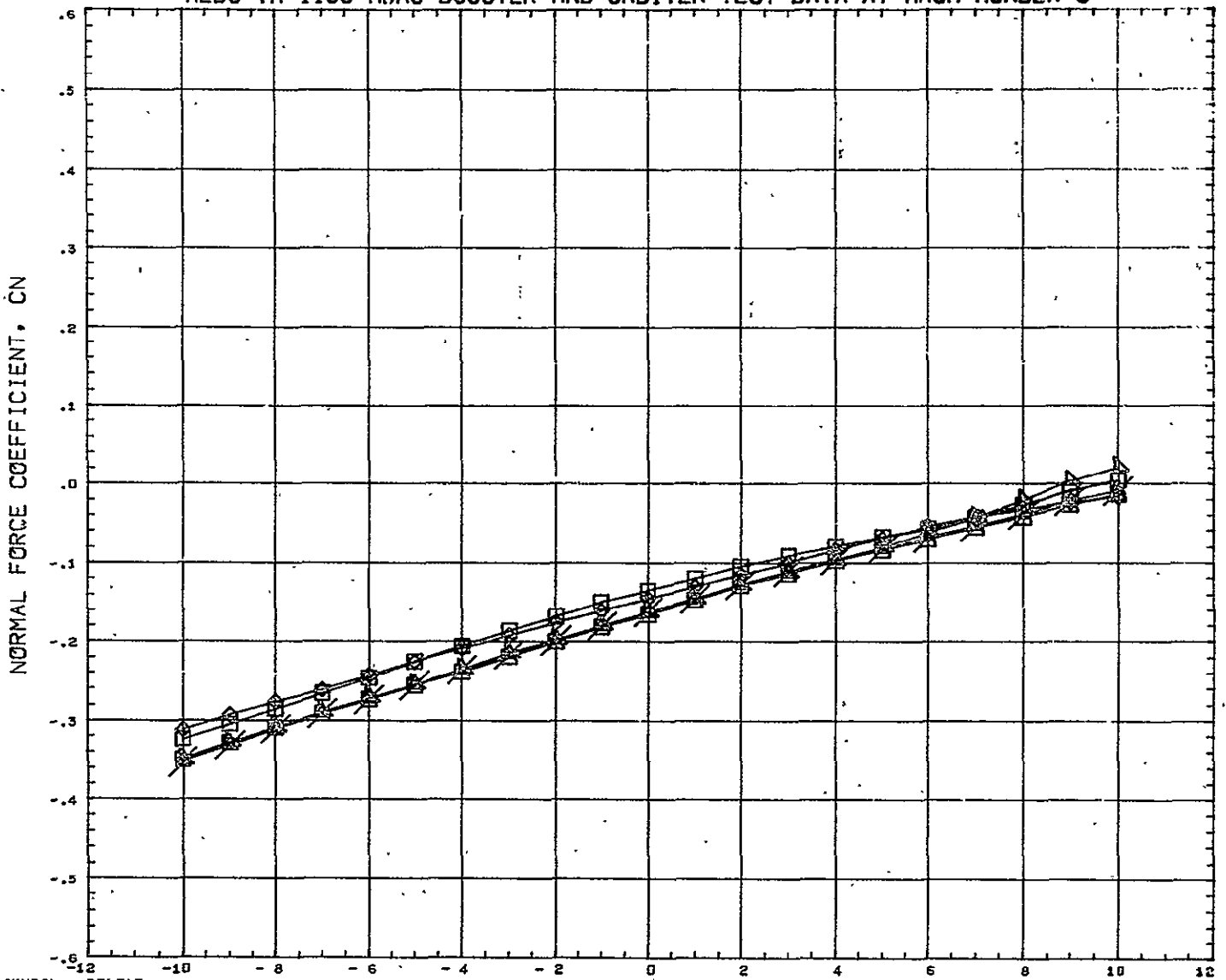

SYMBOL 	DELTAZ 0.182 0.228 0.352 0.599 10.000	<b>PARAMETRIC VALUES</b> BSTPOW    50.000    ORBPOW    100.000 DELTAX    - 0.143    ALPHAI    - 10.000 MACH       5.010    ELVBST    0.000 ELVORB    0.000    BETA       0.000	<b>REFERENCE INFORMATION</b> REFS       23.6890    SQ IN REFL       4.1930    IN REFB       6.5000    IN XMRP       4.9170    IN YMRP       0.0000    IN ZMRP       1.3900    IN SCALE      0.0055
------------	--	--	---

REFERENCE FILE

# AEDC VA 1163 MDAC BOOSTER AND ORBITER TEST DATA AT MACH NUMBER 5

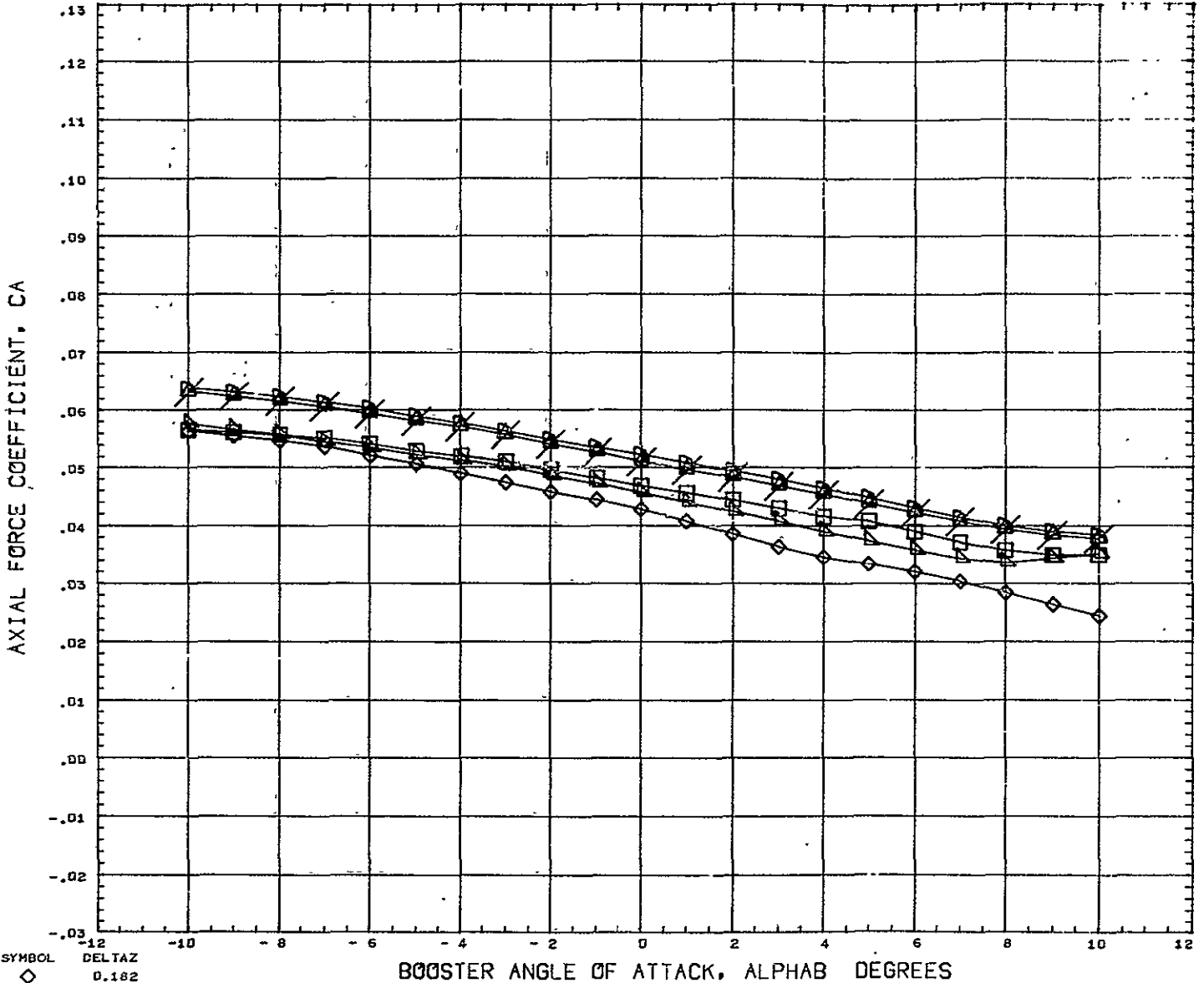

SYMBOL 	DELTAX 0.182 0.228 0.352 0.599 10.000	PARAMETRIC VALUES BSTFOW 50.000 ORBPOW 100.000 DELTAX - 0.143 ALPHAI - 10.000 MACH 5.010 ELVBST 0.000 ELVORB 0.000 BETA 0.000	REFERENCE INFORMATION REFS 23.6890 SQ IN REFL 4.1930 IN REFB 6.5000 IN XMRP 4.9170 IN YMRP 0.0000 IN ZMRP 1.3900 IN SCALE 0.0055
------------	--	---	---

REFERENCE FILE

# AEDC VA 1163 MDAC BOOSTER AND ORBITER TEST DATA AT MACH NUMBER 5

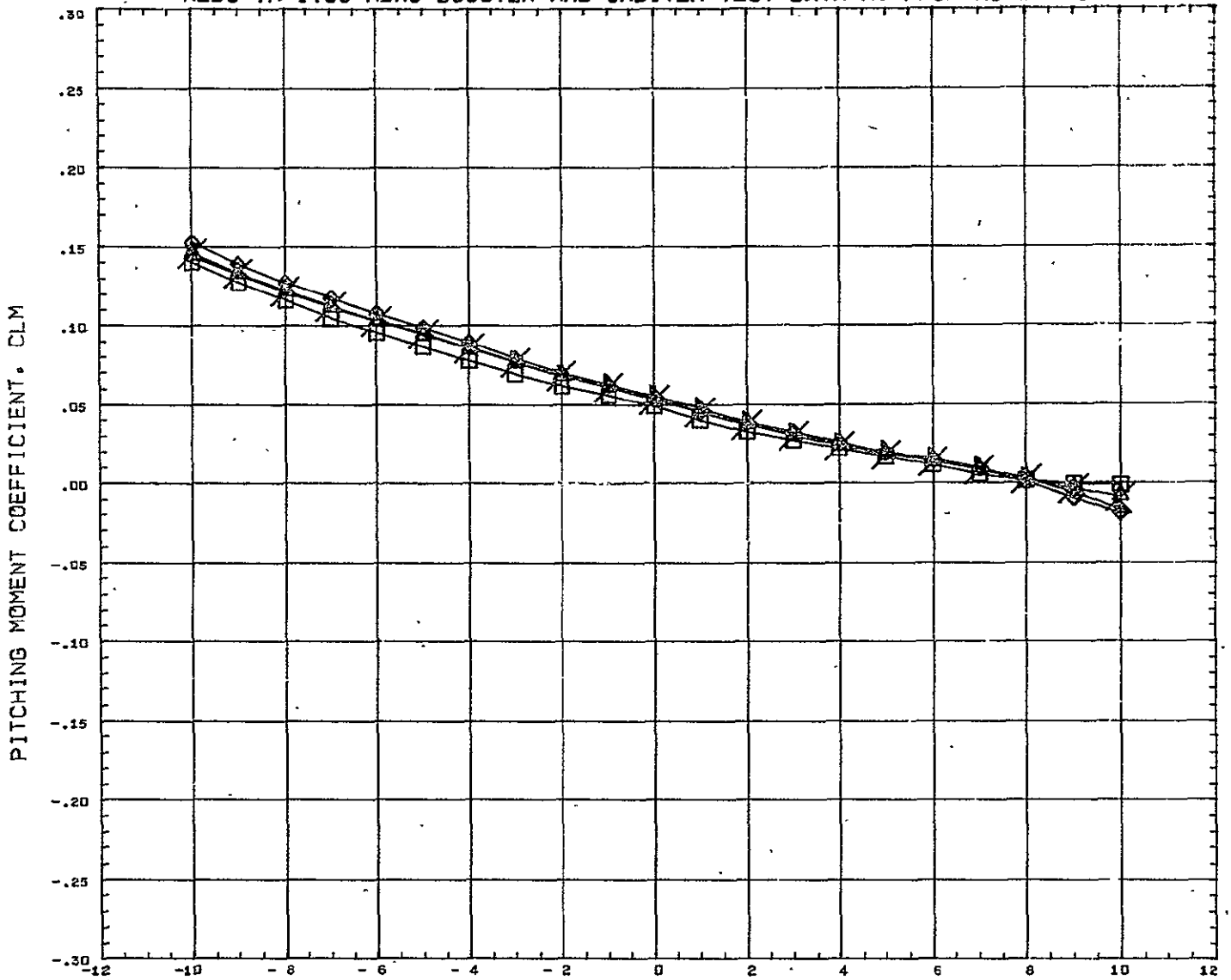

SYMBOL 	DELTA Z 0.162 0.228 0.352 10.000	PARAMETRIC VALUES BSTPOW 50.000 ORBPOW 100.000 DELTAX - 0.019 ALPHAI - 10.000 MACH 5.010 ELVBST 0.000 ELVORB 0.000 BETA 0.000	REFERENCE INFORMATION REFS 23.6890 SQ IN REFL 4.1930 IN REFB 6.5000 IN XMRF 4.9170 IN YMRF 0.0000 IN ZMRF 1.3900 IN SCALE 0.0055
REFERENCE FILE			

# AEDC VA 1163 MDAC BOOSTER AND ORBITER TEST DATA AT MACH NUMBER 5

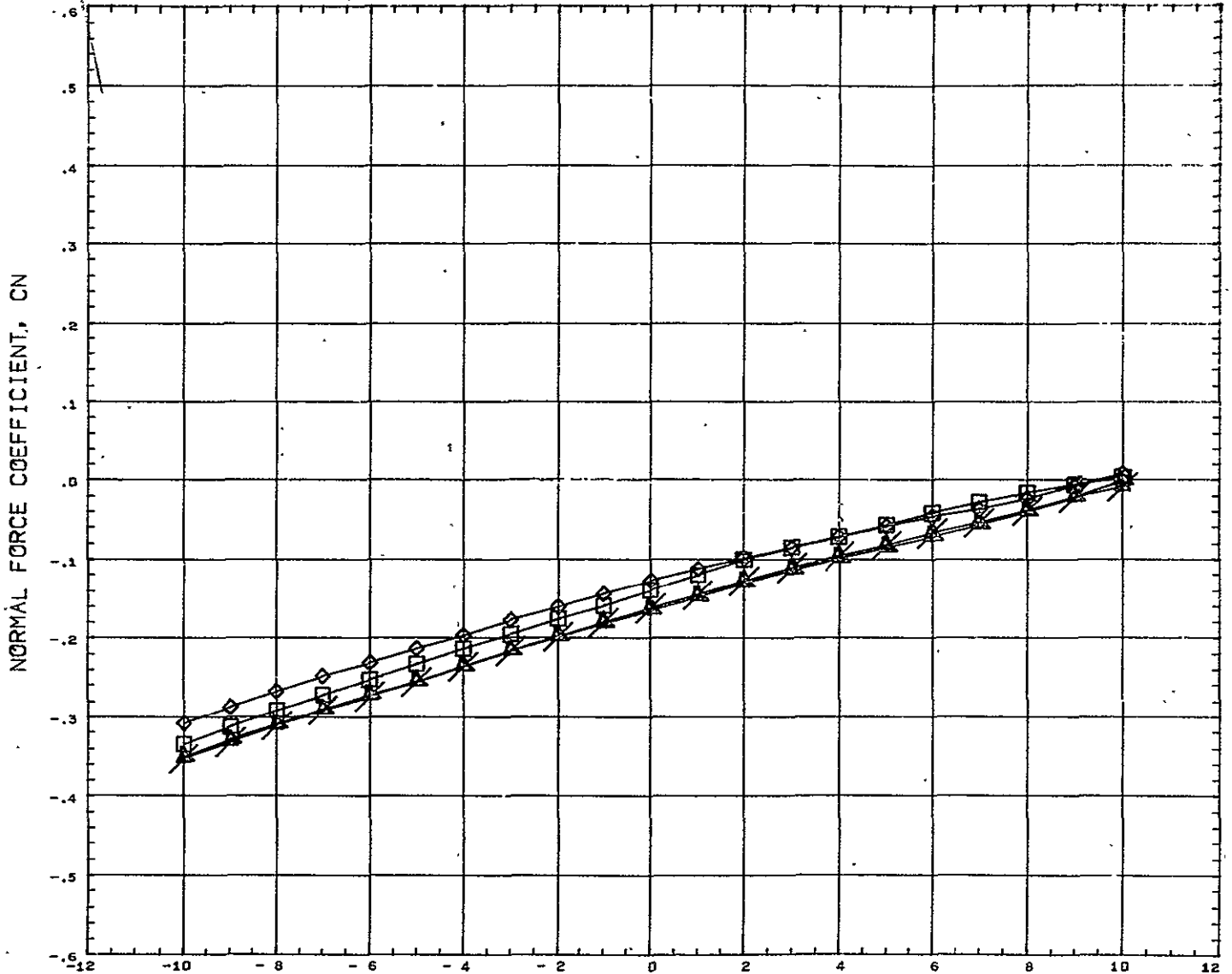

SYMBOL ◇ □ △ ×	DELTAZ 0.182 0.228 0.352 10.000	PARAMETRIC VALUES BSTPOW 50.000 ORBPOW 100.000 DELTAX - 0.019 ALPHAI - 10.000 MACH 5.016 ELVBST 0.000 ELVORB 0.000 BETA 0.000	REFERENCE INFORMATION REFS 23.6890 SQ IN REFL 4.1930 IN REFB 6.5000 IN XMRP 4.9170 IN YMRP 0.0030 IN ZMRP 1.3900 IN SCALE 0.0055
REFERENCE FILE			

# AEDC VA 1163 MDAC BOOSTER AND ORBITER TEST DATA AT MACH NUMBER 5

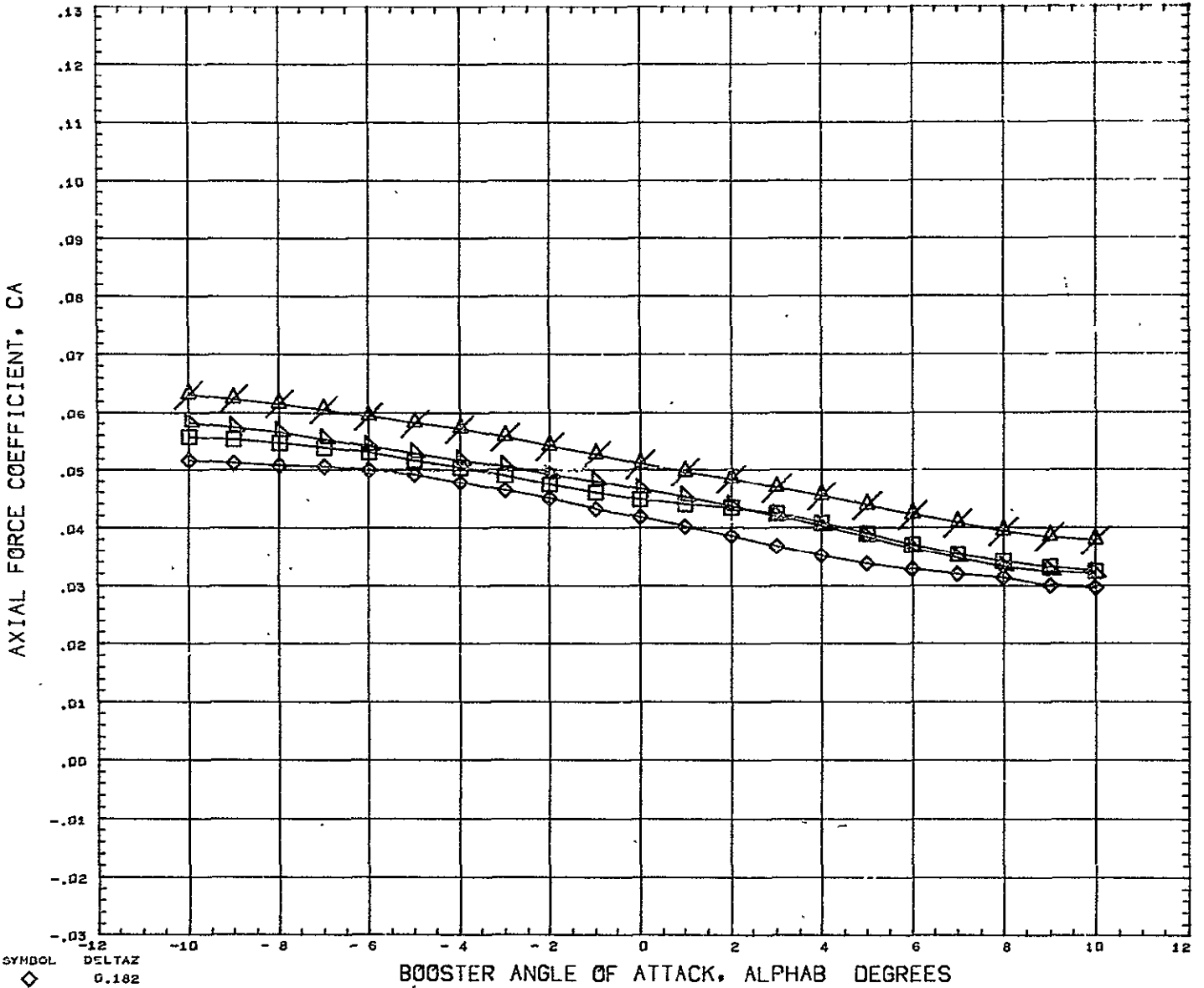

SYMBOL ◇ □ △ ×	DELTAX 0.182 0.228 0.352 10.000	PARAMETRIC VALUES BSTFOW 50.000 ORBPOW 100.000 DELTAX - 0.019 ALPHAI - 10.000 MACH 5.010 ELVBST 0.000 ELVORB 0.000 BETA 0.000	REFERENCE INFORMATION REFS 23.6890 SQ IN REFL 4.1930 IN REFB 6.5000 IN XMRF 4.9170 IN YMRF 0.0000 IN ZMRF 1.3900 IN SCALE 0.0055
REFERENCE FILE			

# AEDC VA 1163 MDAC BOOSTER AND ORBITER TEST DATA AT MACH NUMBER 5

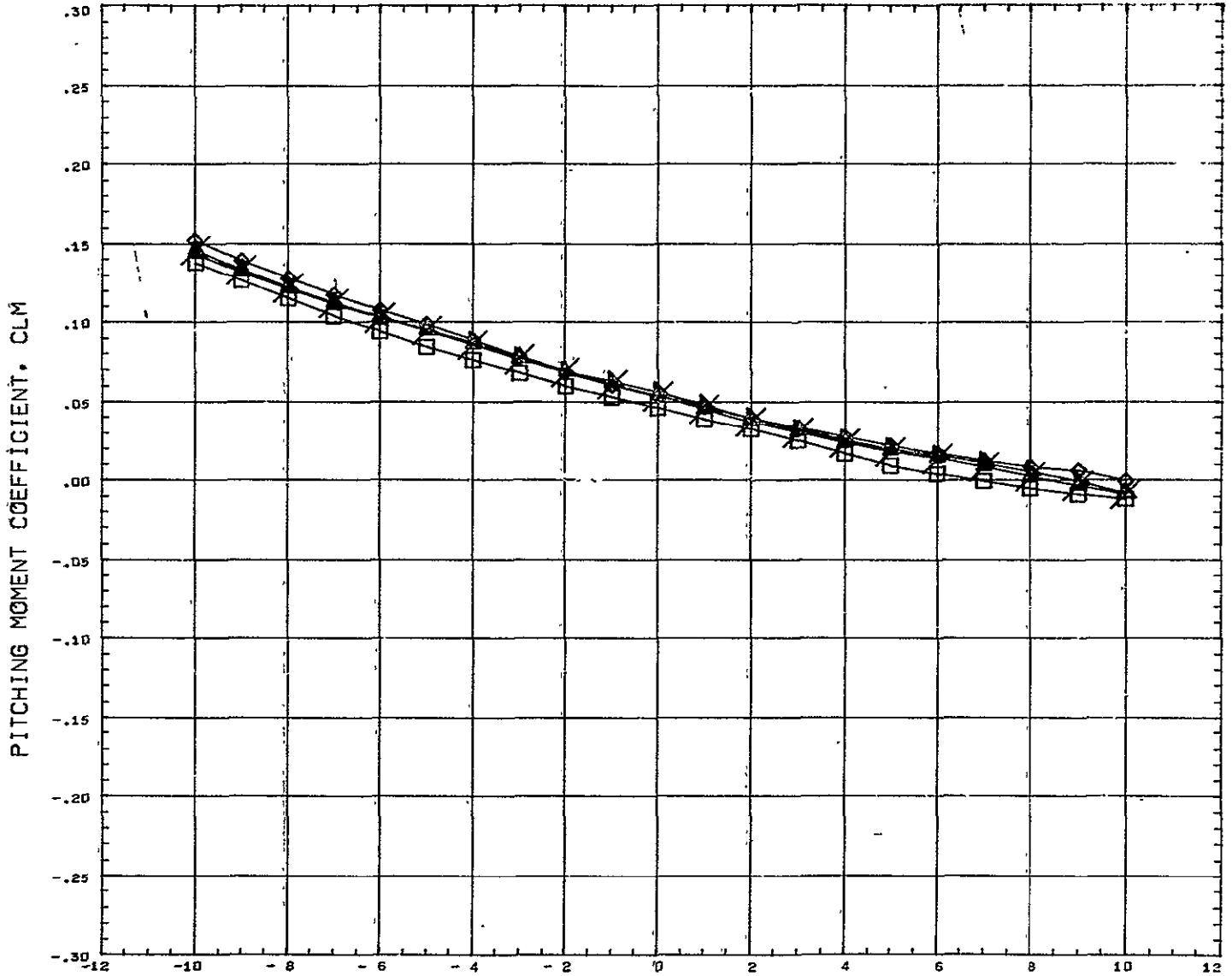

SYMBOL 	DELTAZ 0.182 0.228 0.352 10.000	<table border="0" style="width: 100%;"> <tr> <th colspan="4" style="text-align: left; padding-left: 20px;">PARAMETRIC VALUES</th> </tr> <tr> <td style="padding-right: 20px;">BSTFOW</td> <td style="padding-right: 20px;">50.000</td> <td style="padding-right: 20px;">ORBPOW</td> <td>100.000</td> </tr> <tr> <td style="padding-right: 20px;">DELTAZ</td> <td style="padding-right: 20px;">0.043</td> <td style="padding-right: 20px;">ALPHA1</td> <td>-10.000</td> </tr> <tr> <td style="padding-right: 20px;">MACH</td> <td style="padding-right: 20px;">5.010</td> <td style="padding-right: 20px;">ELVST</td> <td>0.000</td> </tr> <tr> <td style="padding-right: 20px;">ELVORB</td> <td style="padding-right: 20px;">0.000</td> <td style="padding-right: 20px;">BETA</td> <td>0.000</td> </tr> </table>	PARAMETRIC VALUES				BSTFOW	50.000	ORBPOW	100.000	DELTAZ	0.043	ALPHA1	-10.000	MACH	5.010	ELVST	0.000	ELVORB	0.000	BETA	0.000	<table border="0" style="width: 100%;"> <tr> <th colspan="3" style="text-align: left; padding-left: 20px;">REFERENCE INFORMATION</th> </tr> <tr> <td style="padding-right: 20px;">REFS</td> <td style="padding-right: 20px;">23.6890</td> <td>SQ IN</td> </tr> <tr> <td style="padding-right: 20px;">REFL</td> <td style="padding-right: 20px;">4.1930</td> <td>IN</td> </tr> <tr> <td style="padding-right: 20px;">REFB</td> <td style="padding-right: 20px;">6.5000</td> <td>IN</td> </tr> <tr> <td style="padding-right: 20px;">XNRF</td> <td style="padding-right: 20px;">4.9170</td> <td>IN</td> </tr> <tr> <td style="padding-right: 20px;">YNRF</td> <td style="padding-right: 20px;">0.0000</td> <td>IN</td> </tr> <tr> <td style="padding-right: 20px;">ZHRP</td> <td style="padding-right: 20px;">1.3900</td> <td>IN</td> </tr> <tr> <td style="padding-right: 20px;">SCALE</td> <td style="padding-right: 20px;">0.0055</td> <td></td> </tr> </table>	REFERENCE INFORMATION			REFS	23.6890	SQ IN	REFL	4.1930	IN	REFB	6.5000	IN	XNRF	4.9170	IN	YNRF	0.0000	IN	ZHRP	1.3900	IN	SCALE	0.0055	
PARAMETRIC VALUES																																															
BSTFOW	50.000	ORBPOW	100.000																																												
DELTAZ	0.043	ALPHA1	-10.000																																												
MACH	5.010	ELVST	0.000																																												
ELVORB	0.000	BETA	0.000																																												
REFERENCE INFORMATION																																															
REFS	23.6890	SQ IN																																													
REFL	4.1930	IN																																													
REFB	6.5000	IN																																													
XNRF	4.9170	IN																																													
YNRF	0.0000	IN																																													
ZHRP	1.3900	IN																																													
SCALE	0.0055																																														
REFERENCE FILE																																															



# AEDC VA 1163 MDAC BOOSTER AND ORBITER TEST DATA AT MACH NUMBER 5

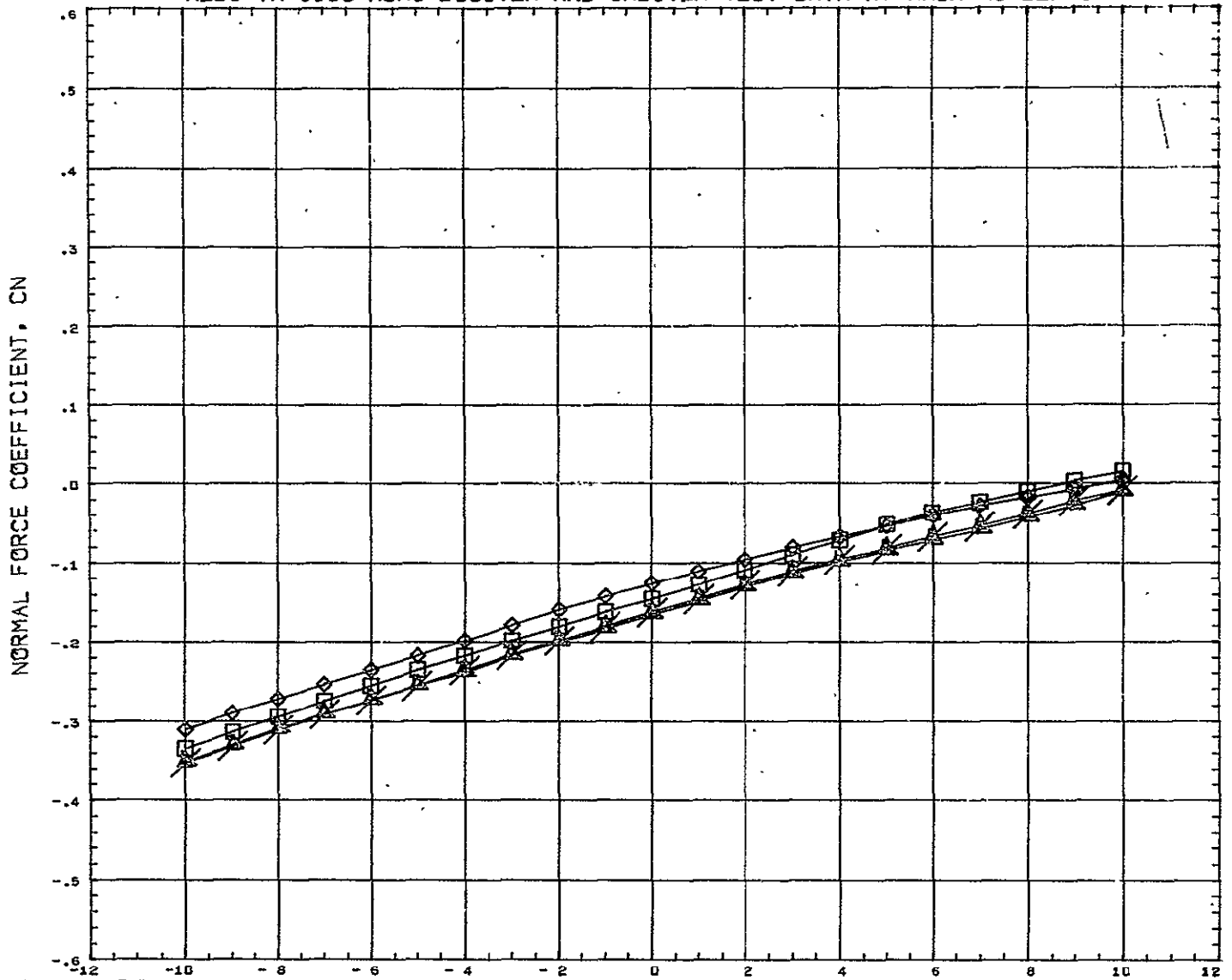

SYMBOL ◇ □ △ ×	DELTAX 0.182 0.228 0.352 10.000	PARAMETRIC VALUES BSTFOW 50.000 ORBPOW 100.000 DELTAX 0.043 ALPHAI - 10.000 MACH 5.010 ELVBST 0.000 ELVORB 0.000 BETA 0.000	REFERENCE INFORMATION REFS 23.6890 SQ IN REFL 4.1930 IN REFB 6.5000 IN XMRP 4.9170 IN YMRP 0.0000 IN ZMRP 1.3900 IN SCALE 0.0055
REFERENCE FILE			

# AEDC VA 1163 MDAC BOOSTER AND ORBITER TEST DATA AT MACH NUMBER 5

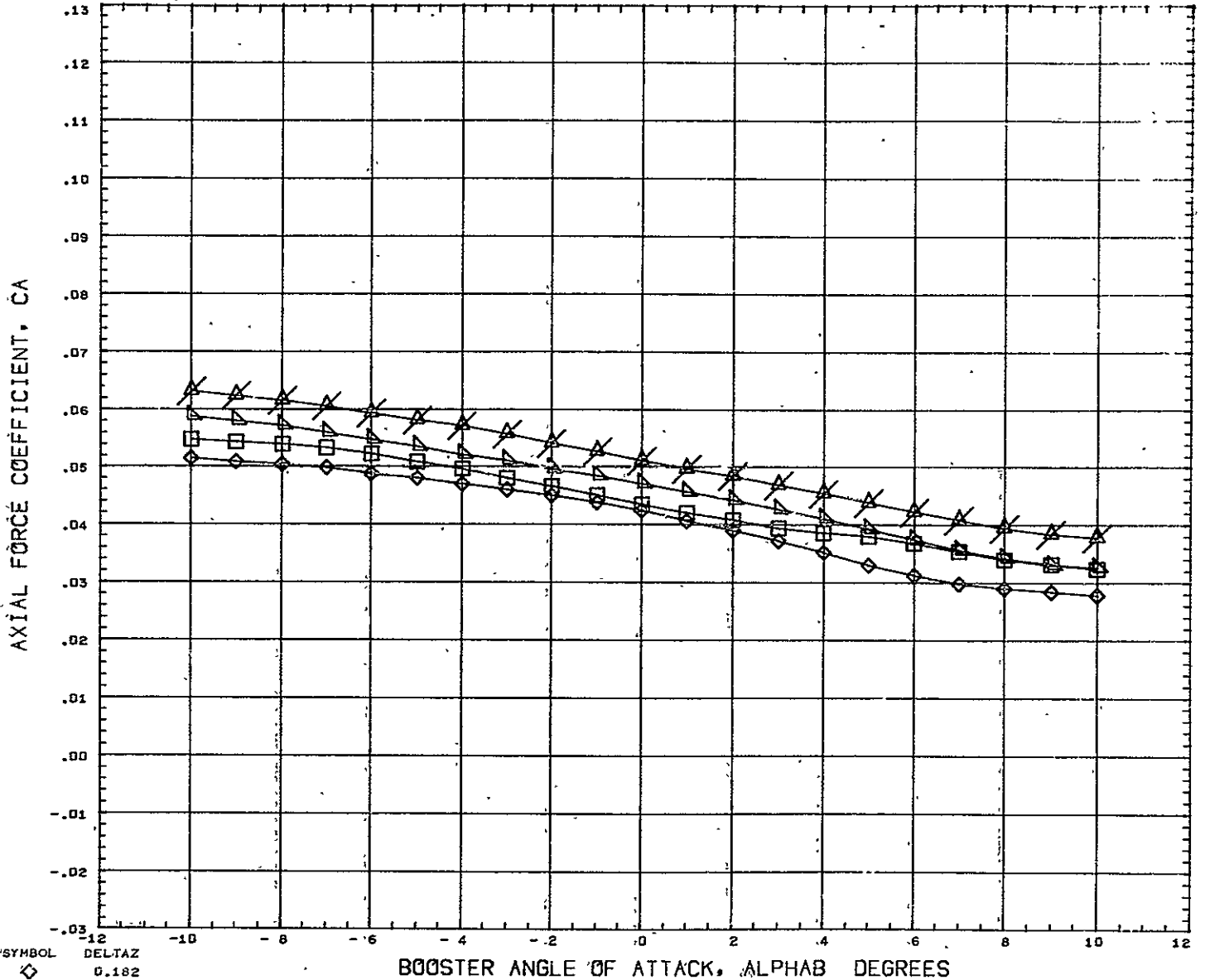

SYMBOL 	DELTA Z	PARAMETRIC VALUES		REFERENCE INFORMATION				
	0.182	BSTPOW	50.000	ORBFOW	100.000	REFS	23.6890	SQ IN
	0.228	DELTA X	0.043	ALPHA I	-10.000	REFL	4.1930	IN
	0.352	MACH	5.010	ELVBST	0.000	REFB	6.5000	IN
10.000	ELVORB	0.000	BETA	0.000	XMRP	4.9170	IN	
					YMRP	0.0000	IN	
					ZMRP	1.3900	IN	
					SCALE	0.0055		

REFERENCE FILE

# AEDC VA 1163 MDAC BOOSTER AND ORBITER TEST DATA AT MACH NUMBER 5

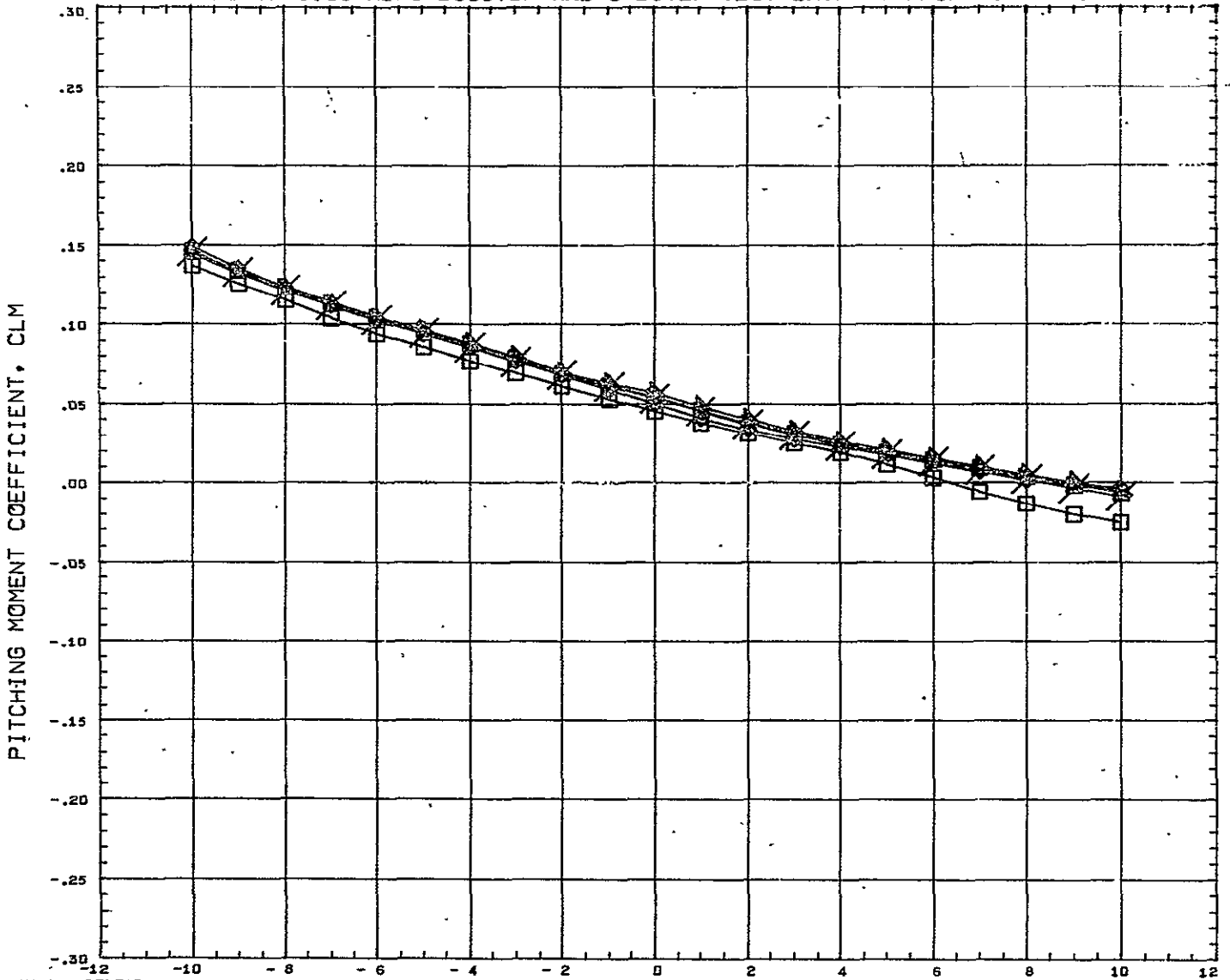

SYMBOL ◊ ◻ △	DELTA Z 0.182 0.228 0.352 0.599 10.000	PARAMETRIC VALUES BSTFOW 50.000 ORBFOW 100.000 DELTAX 0.105 ALPHAI - 10.000 MACH 5.010 ELVBST 0.000 ELVORB 0.000 BETA 0.000	REFERENCE INFORMATION REFS 23.6890 SQ IN REFL 4.1930 IN REFB 6.5000 IN XMRP 4.9170 IN YMRP 0.0000 IN ZMRP 1.3900 IN SCALE 0.0055
-----------------------	---	---	---

REFERENCE FILE

# AEDC VA 1163 MDAC BOOSTER AND ORBITER TEST DATA AT MACH NUMBER 5

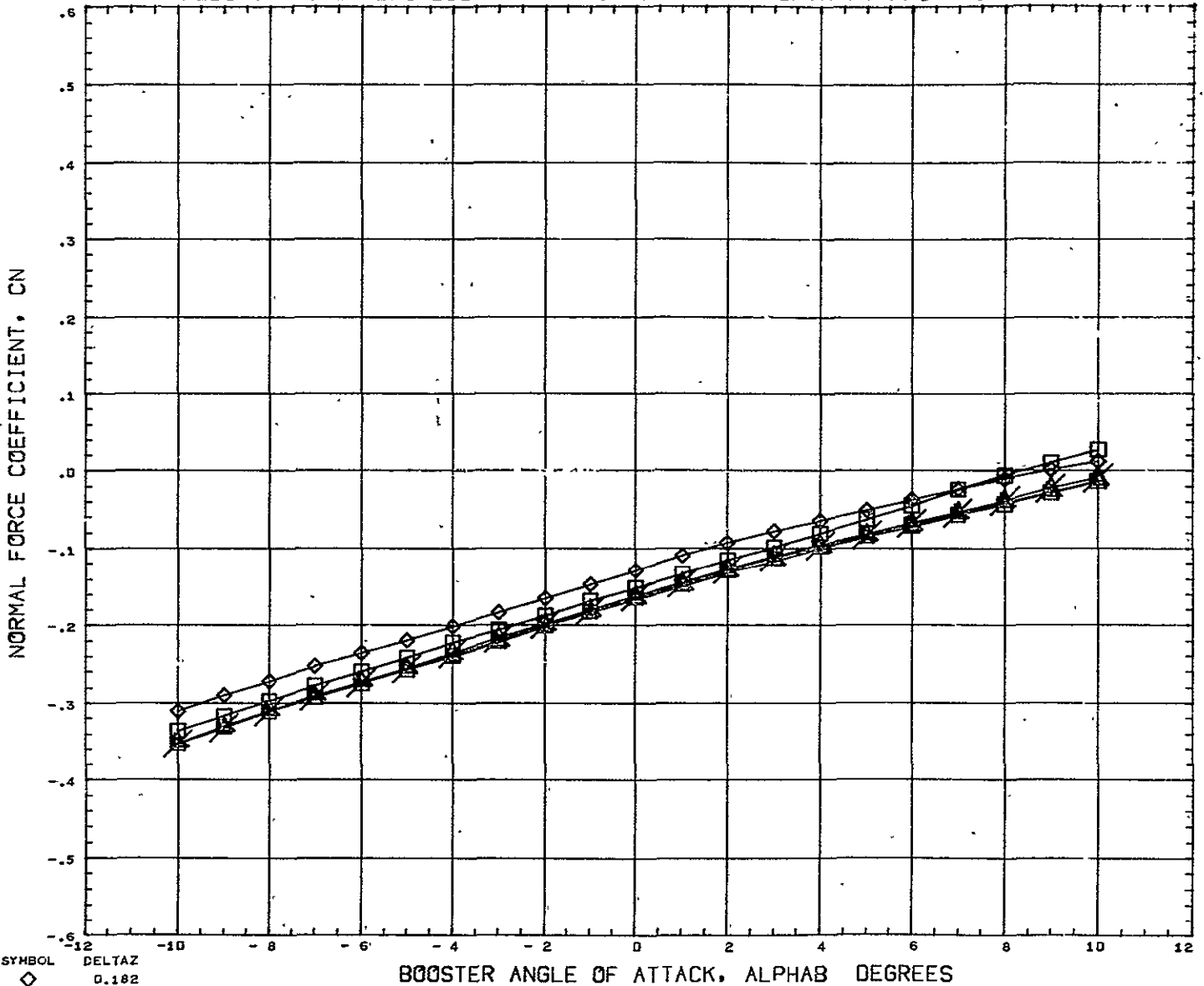

SYMBOL

DELTA Z

0.182

0.228

0.352

0.599

10.000

BSTFOW

PARAMETRIC VALUES

50.000

ORBPOW

100.000

DELTA X

0.105

ALPHA I

-10.000

MACH

5.010

ELVBST

0.000

ELVORB

0.000

BETA

0.000

REFERENCE INFORMATION

REFS

23.6890

50 IN

REFL

4.1930

IN

REFB

6.5000

IN

XMRP

4.9170

IN

YMRP

0.0000

IN

ZMRP

1.3900

IN

SCALE

0.0055

REFERENCE FILE

# AEDC VA 1163 MDAC BOOSTER AND ORBITER TEST DATA AT MACH NUMBER 5

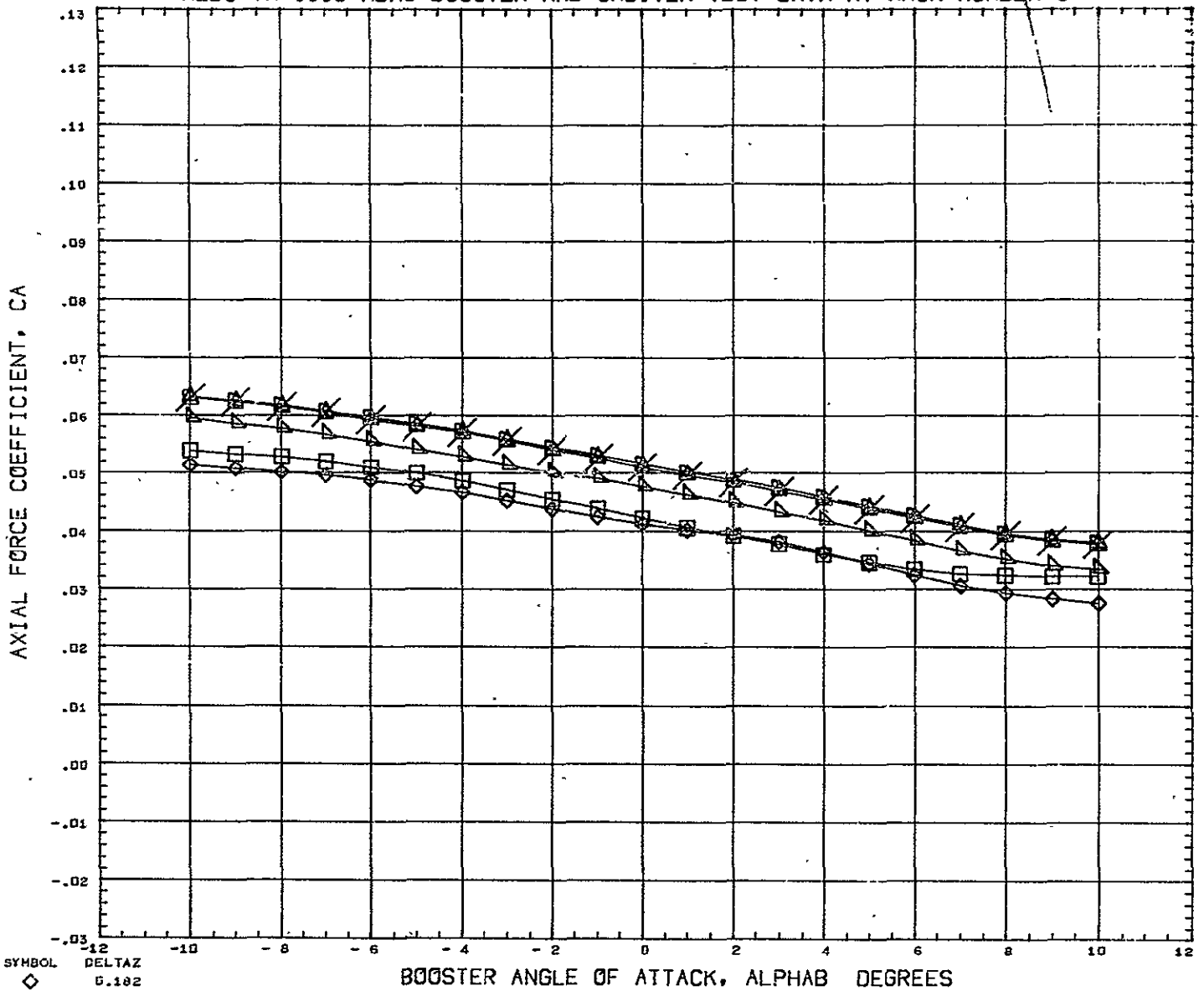

SYMBOL ◇ □ △ ▽ ×	DELTAZ 0.182 0.228 0.352 0.599 10.000	<table border="0" style="width: 100%;"> <tr> <th colspan="4" style="text-align: left;">PARAMETRIC VALUES</th> </tr> <tr> <td>BSTPOW</td><td>50.000</td><td>ORBPOW</td><td>100.000</td> </tr> <tr> <td>DELTA X</td><td>0.105</td><td>ALPHA I</td><td>-10.000</td> </tr> <tr> <td>MACH</td><td>5.010</td><td>ELVBST</td><td>0.000</td> </tr> <tr> <td>ELVORB</td><td>0.000</td><td>BETA</td><td>0.000</td> </tr> </table>	PARAMETRIC VALUES				BSTPOW	50.000	ORBPOW	100.000	DELTA X	0.105	ALPHA I	-10.000	MACH	5.010	ELVBST	0.000	ELVORB	0.000	BETA	0.000	<table border="0" style="width: 100%;"> <tr> <th colspan="3" style="text-align: left;">REFERENCE INFORMATION</th> </tr> <tr> <td>REFS</td><td>23.6890</td><td>SQ IN</td> </tr> <tr> <td>REFL</td><td>4.1950</td><td>IN</td> </tr> <tr> <td>REFB</td><td>6.5000</td><td>IN</td> </tr> <tr> <td>XMRP</td><td>4.9170</td><td>IN</td> </tr> <tr> <td>YMRP</td><td>0.0000</td><td>IN</td> </tr> <tr> <td>ZMRP</td><td>1.3900</td><td>IN</td> </tr> <tr> <td>SCALE</td><td>0.0055</td><td></td> </tr> </table>	REFERENCE INFORMATION			REFS	23.6890	SQ IN	REFL	4.1950	IN	REFB	6.5000	IN	XMRP	4.9170	IN	YMRP	0.0000	IN	ZMRP	1.3900	IN	SCALE	0.0055	
PARAMETRIC VALUES																																															
BSTPOW	50.000	ORBPOW	100.000																																												
DELTA X	0.105	ALPHA I	-10.000																																												
MACH	5.010	ELVBST	0.000																																												
ELVORB	0.000	BETA	0.000																																												
REFERENCE INFORMATION																																															
REFS	23.6890	SQ IN																																													
REFL	4.1950	IN																																													
REFB	6.5000	IN																																													
XMRP	4.9170	IN																																													
YMRP	0.0000	IN																																													
ZMRP	1.3900	IN																																													
SCALE	0.0055																																														
REFERENCE FILE																																															

# AEDC VA 1163 MDAC BOOSTER AND ORBITER TEST DATA AT MACH NUMBER 5

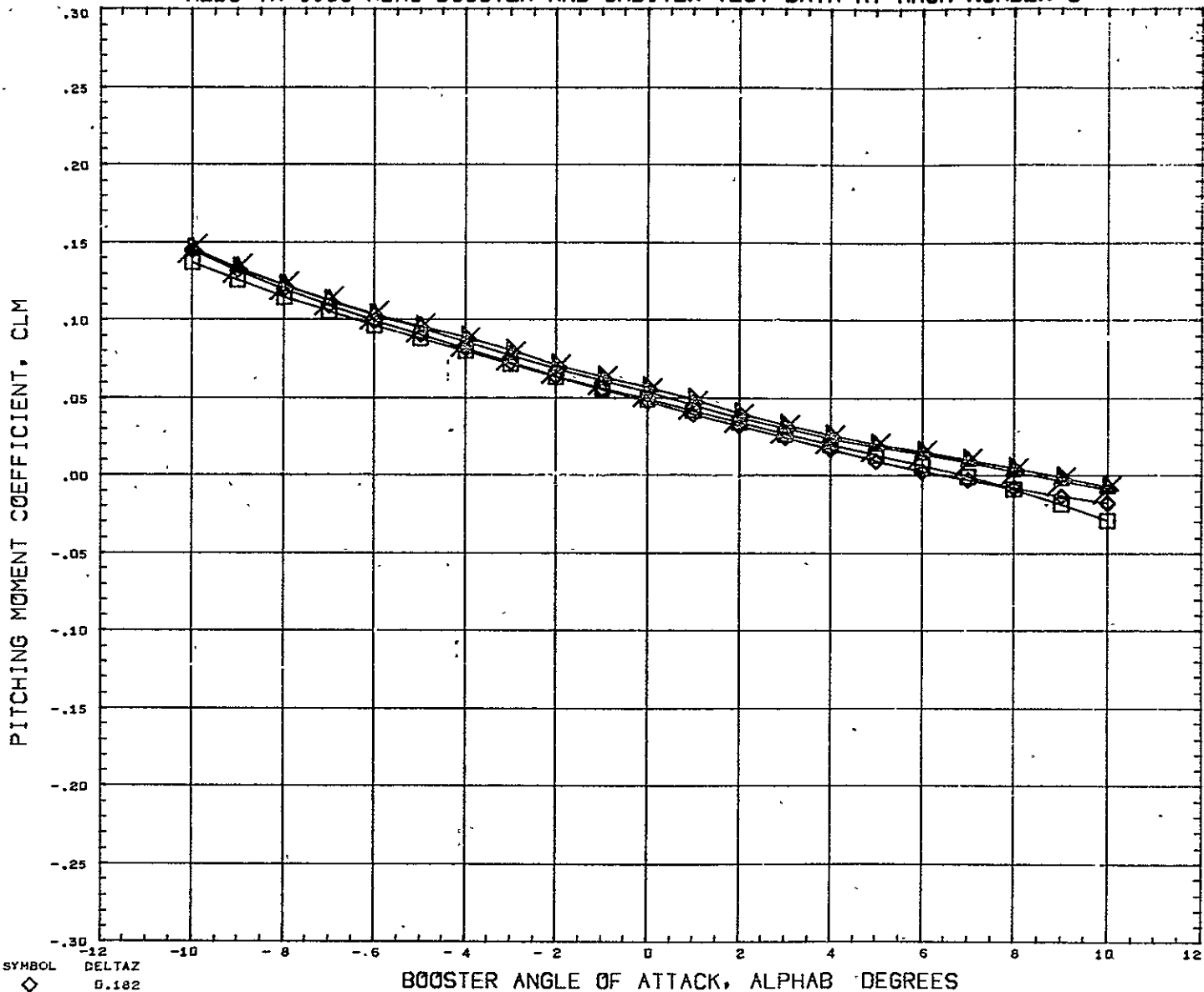

SYMBOL ◇ □ △	DELTAX 0.182 0.228 0.352 10.000	PARAMETRIC VALUES BSTFOW 50.000 ORBFOV 100.000 DELTAX 0.167 ALPHAI - 10.000 MACH 5.010 ELVBST 0.000 ELVORB 0.000 BETA 0.000	REFERENCE INFORMATION REFS 23.6890 SQ IN REFL 4.1930 IN REFB 6.5000 IN XMRP 4.9170 IN YMRP 0.0000 IN ZMRP 1.3900 IN SCALE 0.0055
-----------------------	---	---	---

REFERENCE FILE

# AEDC VA 1163 MDAC BOOSTER AND ORBITER TEST DATA AT MACH NUMBER 5

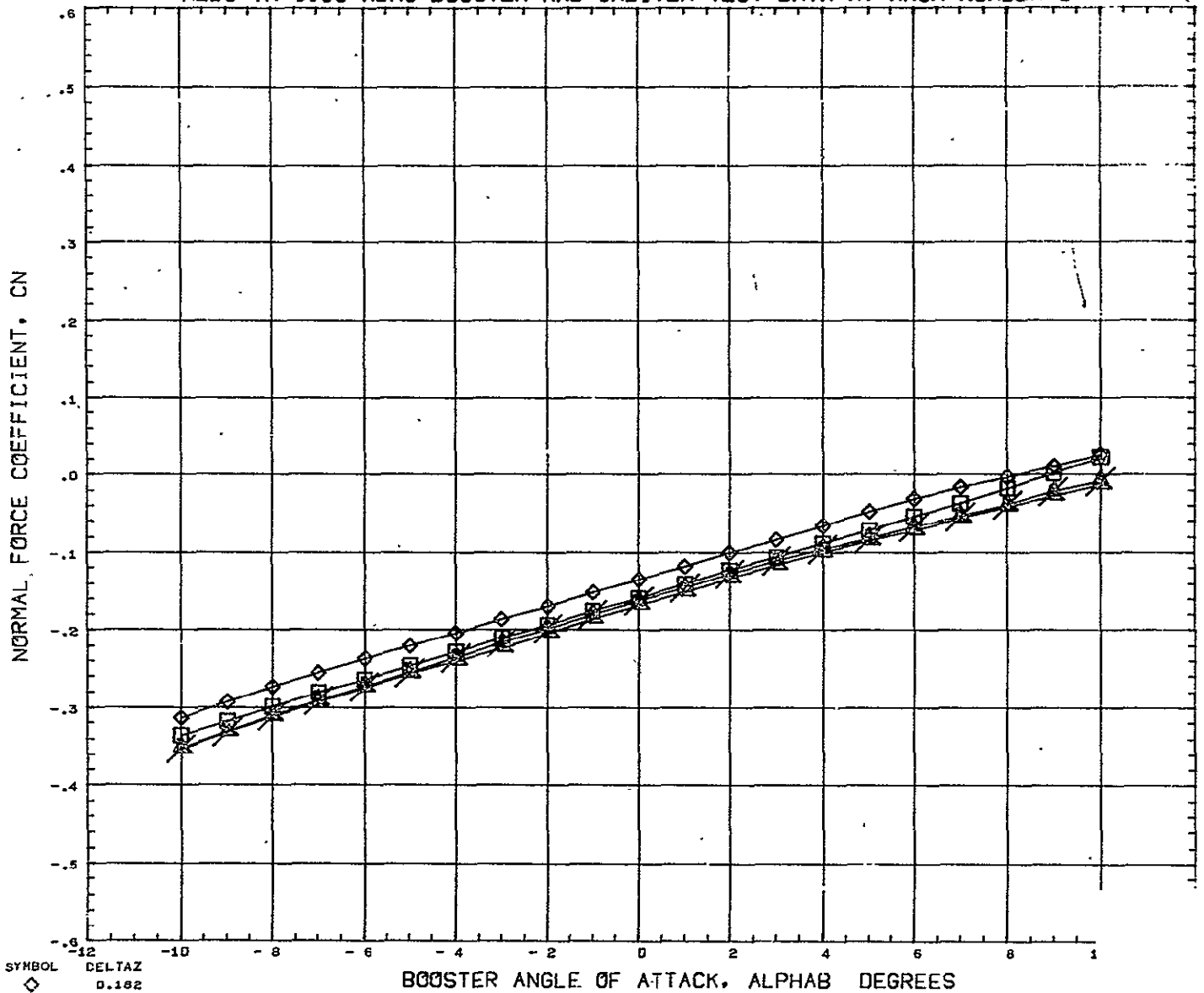

SYMBOL ◇ □ △ ×	DELTAZ 0.162 0.228 0.352 10.000	<b>PARAMETRIC VALUES</b> BSTPOW 50.000 ORBPOW 100.000 DELTAX 0.167 ALPHAI - 10.000 MACH 5.010 ELVBST 0.000 ELVORB 0.000 BETA 0.000	<b>REFERENCE INFOR</b> REFS 23.6890 REFL 4.1930 REFB 6.5000 XMRP 4.9170 YMRP 0.0000 ZMRP 1.3900 SCALE 0.0055
REFERENCE FILE			

# AEDC VA 1163 MDAC BOOSTER AND ORBITER TEST DATA AT MACH NUMBER 5

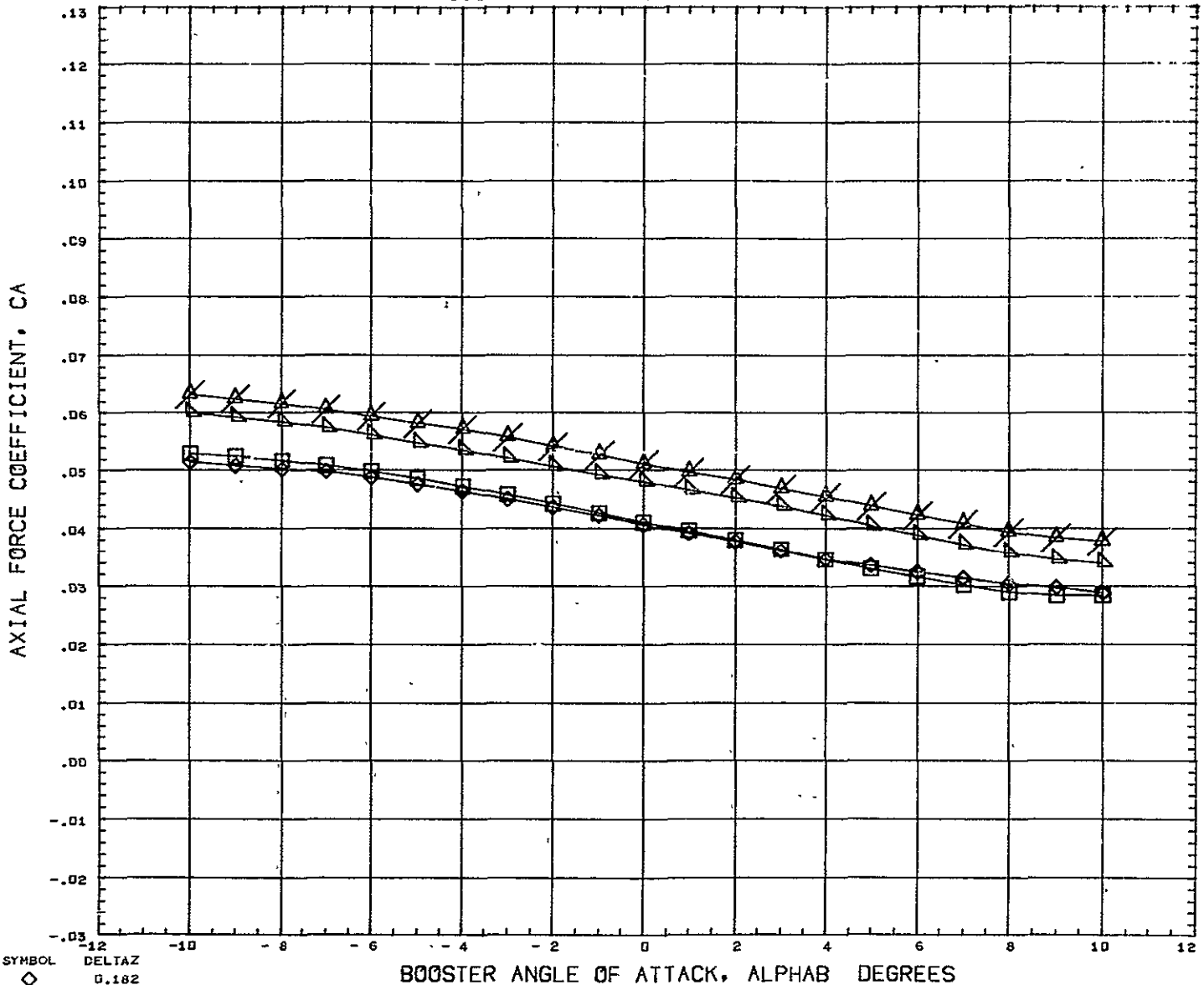

SYMBOL ◻ ◻ ◻	DELTAX 0.182 0.228 0.352 10.000	PARAMETRIC VALUES 3STFOW 50.000 ORBPOW 100.000 DELTAX 0.167 ALPHAI - 10.000 MACH 5.010 ELVBST 0.000 ELVORB 0.000 BETA 0.000	REFERENCE INFORMATION REFS 23.6890 SQ IN REFL 4.1930 IN REFB 6.5000 IN XMRP 4.9170 IN YMRP 0.0000 IN ZMRP 1.3900 IN SCALE 0.0055
-----------------------	---	---	---

REFERENCE FILE



# AEDC VA 1163 MDAC BOOSTER AND ORBITER TEST DATA AT MACH NUMBER 5

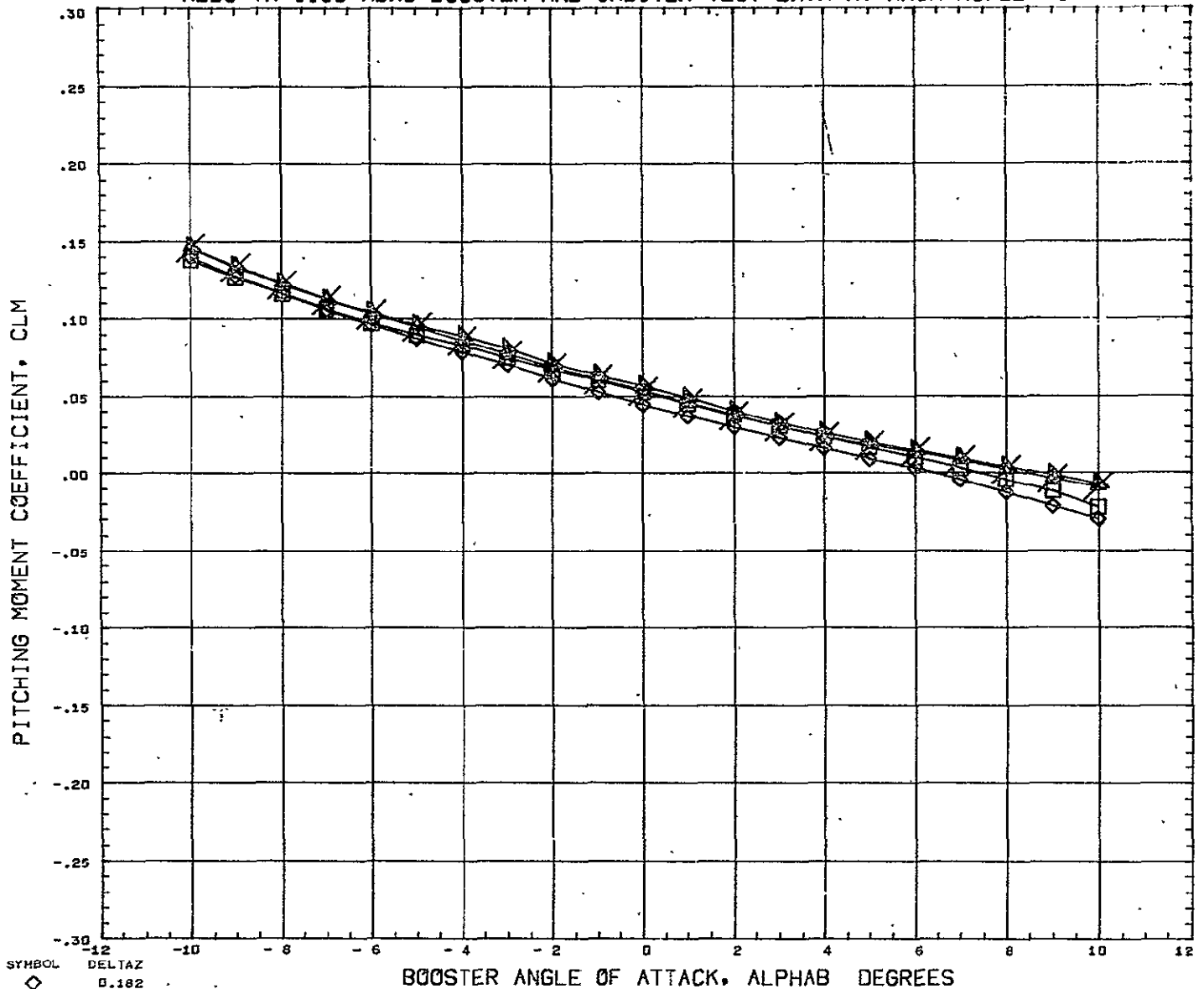

SYMBOL ◊ ◻ △	DELTAX 0.182 0.228 0.352 10.000	PARAMETRIC VALUES BSTPOW 50.000 ORBPOW 100.000 DELTAX 0.228 ALPHAI - 10.000 MACH 5.010 ELVBST 0.000 ELVORB 0.000 BETA 0.000	REFERENCE INFORMATION REFS 23.6890 SQ IN REFL 4.1930 IN REFB 6.5000 IN XHRF 4.9170 IN YHRF 0.0000 IN ZHRF 1.3900 IN SCALE 0.0055
REFERENCE FILE			

# AEDC VA 1163 MDAC BOOSTER AND ORBITER TEST DATA AT MACH NUMBER 5

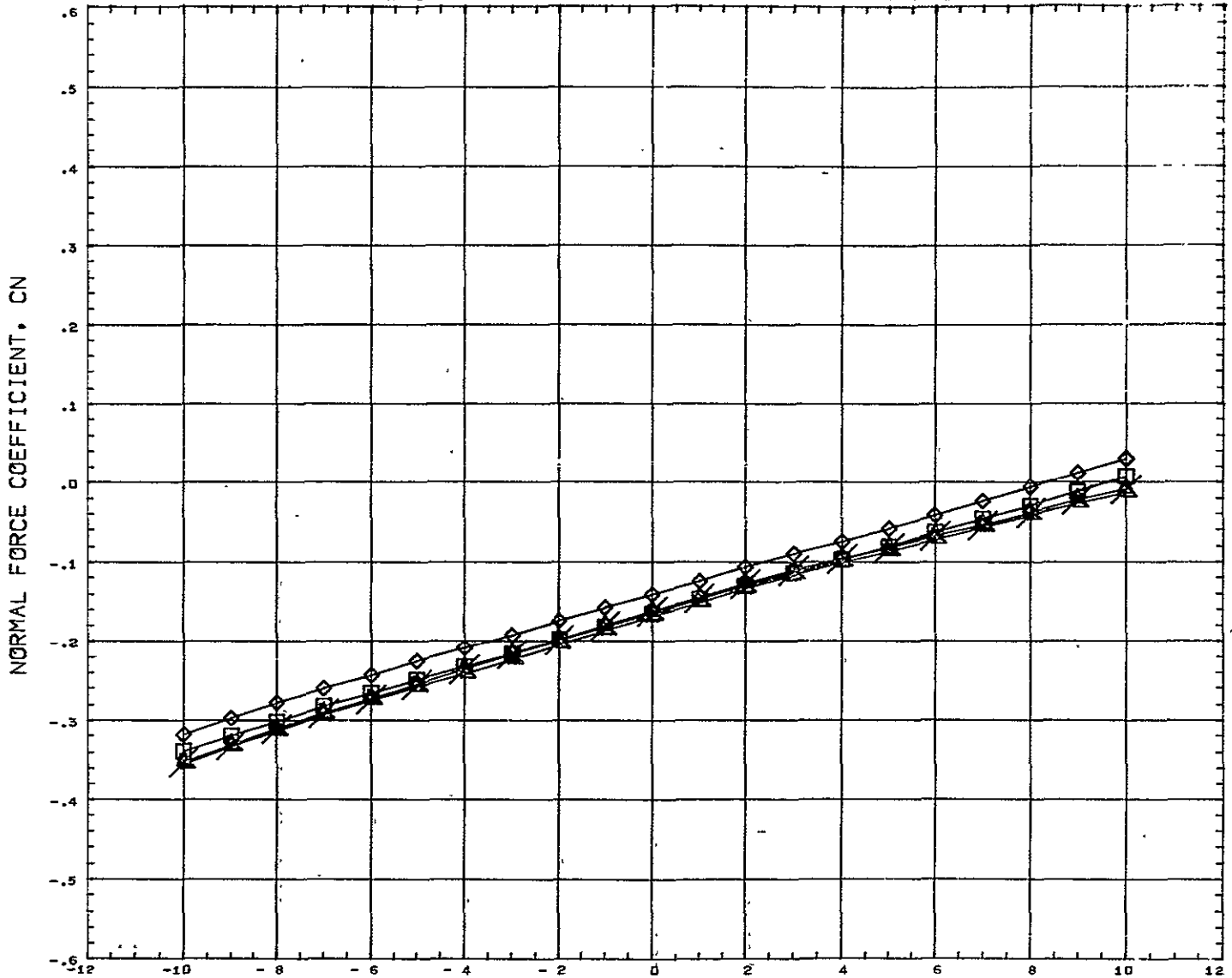

SYMBOL 	DELTAZ 0.182 0.228 0.352 10.000	PARAMETRIC VALUES BSTPOW 50.000 ORBPOW 100.000 DELTAX 0.228 ALPHAI - 10.000 MACH 5.016 ELVBST 0.000 ELVORB 0.000 BETA 0.000	REFERENCE INFORMATION REFS 23.6890 SQ IN REFL 4.1930 IN REFB 6.5000 IN XMRP 4.9170 IN YMRP 0.0000 IN ZMRP 1.3900 IN SCALE 0.0055
REFERENCE FILE			

# AEDC VA 1163 MDAC BOOSTER AND ORBITER TEST DATA AT MACH NUMBER 5

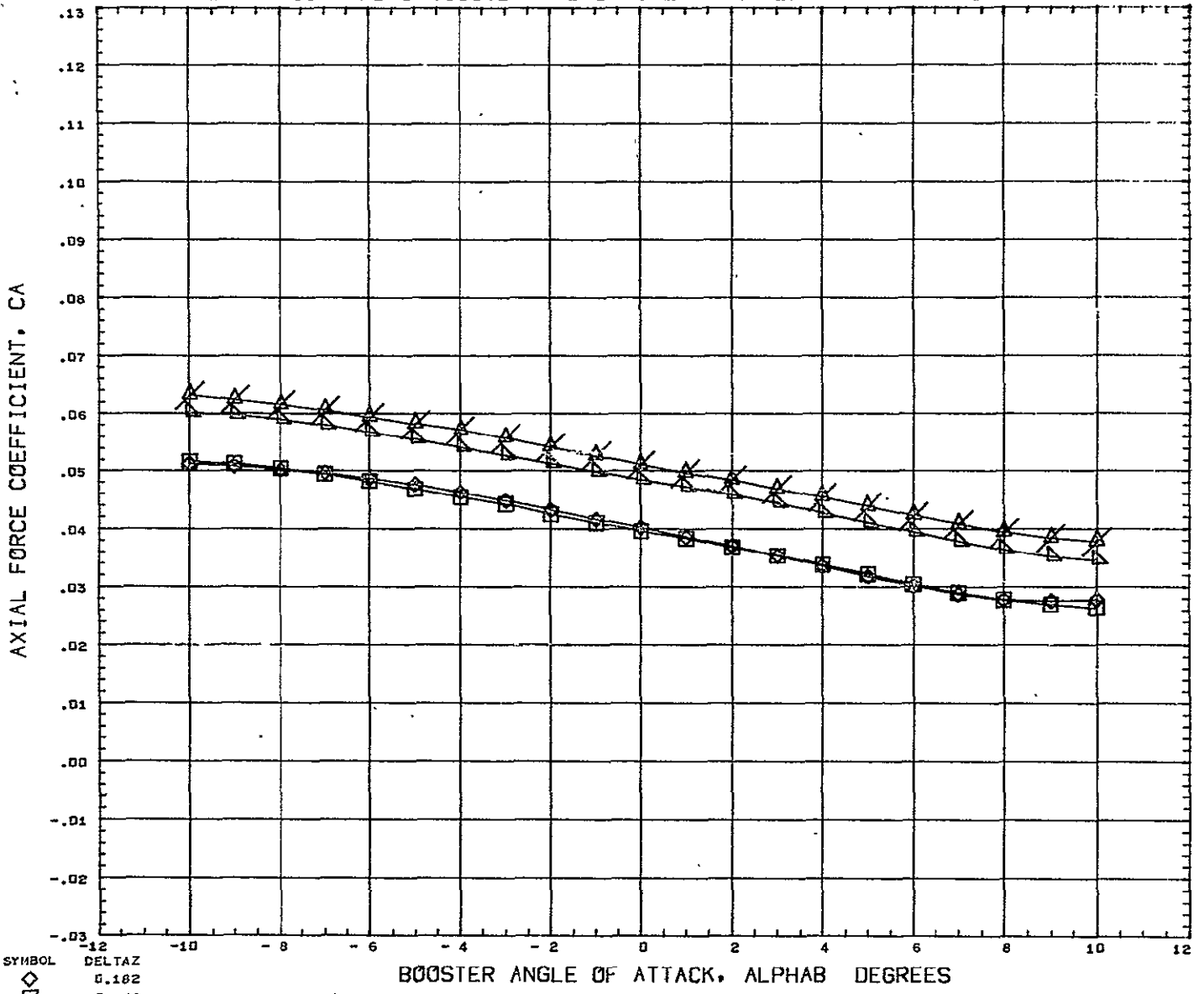

SYMBOL    DELTA Z  
 ◻        0.182  
 ◻        0.228  
 ◻        0.352  
 ◻        10.000

PARAMETRIC VALUES  
 BSTPOW    50.000    ORBPOW    100.000  
 DELTAX    0.228    ALPHAI    - 10.000  
 MACH       5.010    ELVBST    0.000  
 ELVORB    0.000    BETA       0.000

REFERENCE INFORMATION  
 REFS       23.6890    SQ IN  
 REFL       4.1930    IN  
 REFB       6.5000    IN  
 XMRP       4.9170    IN  
 YMRP       0.0000    IN  
 ZMRP       1.3900    IN  
 SCALE       0.0055

REFERENCE FILE

# AEDC VA 1163 MDAC BOOSTER AND ORBITER TEST DATA AT MACH NUMBER 5

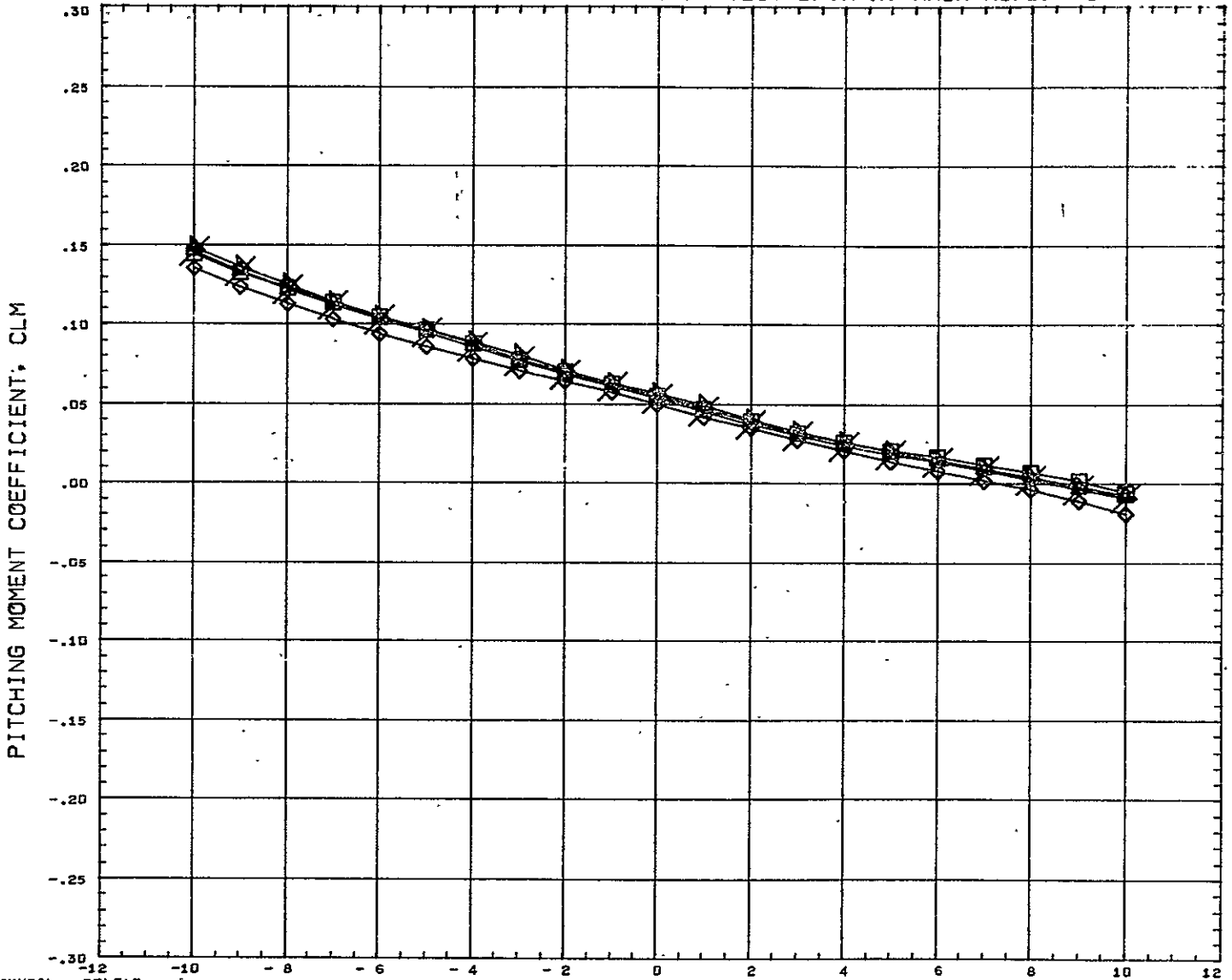

SYMBOL 	DELTAZ 0.182 0.228 0.352 10.000	<table border="0" style="width: 100%;"> <tr> <th colspan="4" style="text-align: left;">PARAMETRIC VALUES</th> </tr> <tr> <td>BSTPOW</td><td>50.000</td><td>ORBPOW</td><td>100.000</td> </tr> <tr> <td>DELTA X</td><td>0.352</td><td>ALPHA I</td><td>-10.000</td> </tr> <tr> <td>MACH</td><td>5.010</td><td>ELVBST</td><td>0.000</td> </tr> <tr> <td>ELVORB</td><td>0.000</td><td>BETA</td><td>0.000</td> </tr> </table>	PARAMETRIC VALUES				BSTPOW	50.000	ORBPOW	100.000	DELTA X	0.352	ALPHA I	-10.000	MACH	5.010	ELVBST	0.000	ELVORB	0.000	BETA	0.000	<table border="0" style="width: 100%;"> <tr> <th colspan="3" style="text-align: left;">REFERENCE INFORMATION</th> </tr> <tr> <td>REFS</td><td>23.6890</td><td>SQ IN</td> </tr> <tr> <td>REFL</td><td>4.1930</td><td>IN</td> </tr> <tr> <td>REFB</td><td>6.5000</td><td>IN</td> </tr> <tr> <td>XMRP</td><td>4.9170</td><td>IN</td> </tr> <tr> <td>YMRP</td><td>0.0000</td><td>IN</td> </tr> <tr> <td>ZMRP</td><td>1.3900</td><td>IN</td> </tr> <tr> <td>SCALE</td><td>0.0055</td><td></td> </tr> </table>	REFERENCE INFORMATION			REFS	23.6890	SQ IN	REFL	4.1930	IN	REFB	6.5000	IN	XMRP	4.9170	IN	YMRP	0.0000	IN	ZMRP	1.3900	IN	SCALE	0.0055	
PARAMETRIC VALUES																																															
BSTPOW	50.000	ORBPOW	100.000																																												
DELTA X	0.352	ALPHA I	-10.000																																												
MACH	5.010	ELVBST	0.000																																												
ELVORB	0.000	BETA	0.000																																												
REFERENCE INFORMATION																																															
REFS	23.6890	SQ IN																																													
REFL	4.1930	IN																																													
REFB	6.5000	IN																																													
XMRP	4.9170	IN																																													
YMRP	0.0000	IN																																													
ZMRP	1.3900	IN																																													
SCALE	0.0055																																														
REFERENCE FILE																																															

AEDC VA 1163 MDAC BOOSTER AND ORBITER TEST DATA AT MACH NUMBER 5

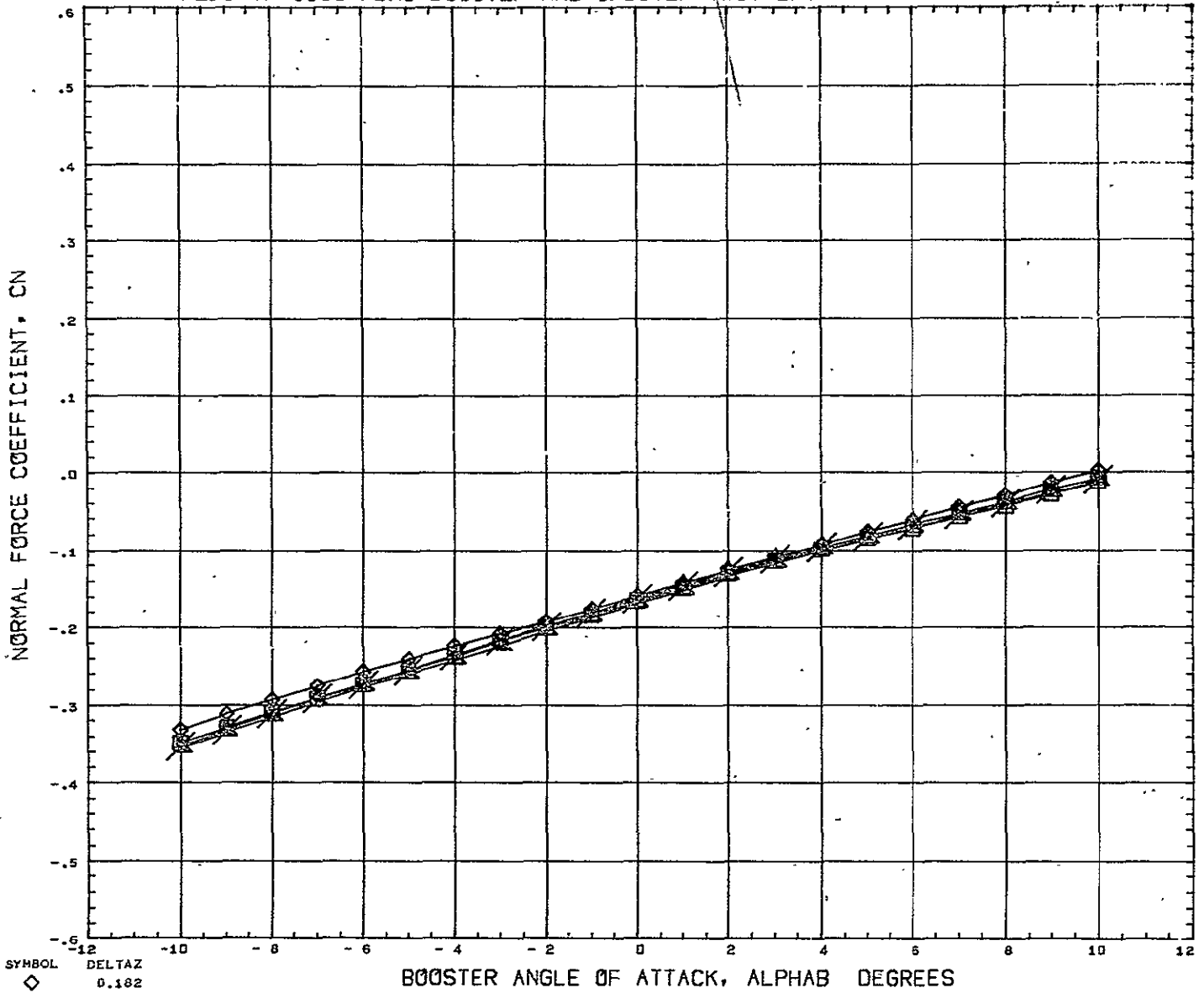

SYMBOL  
 ◇ 0.182  
 □ 0.228  
 ▲ 0.352  
 ▽ 10.000

PARAMETRIC VALUES  
 BSTPOW 50.000 ORBPOW 100.000  
 DELTAX 0.352 ALPHAI - 10.000  
 MACH 5.010 ELVBST 0.000  
 ELVORB 0.000 BETA 0.000

REFERENCE INFORMATION  
 REFS 23.6890 SQ IN  
 REFL 4.1930 IN  
 REFB 6.5000 IN  
 XMRP 4.9170 IN  
 YMRP 0.0000 IN  
 ZMRP 1.3900 IN  
 SCALE 0.0055

REFERENCE FILE

# AEDC VA 1163 MDAC BOOSTER AND ORBITER TEST DATA AT MACH NUMBER 5

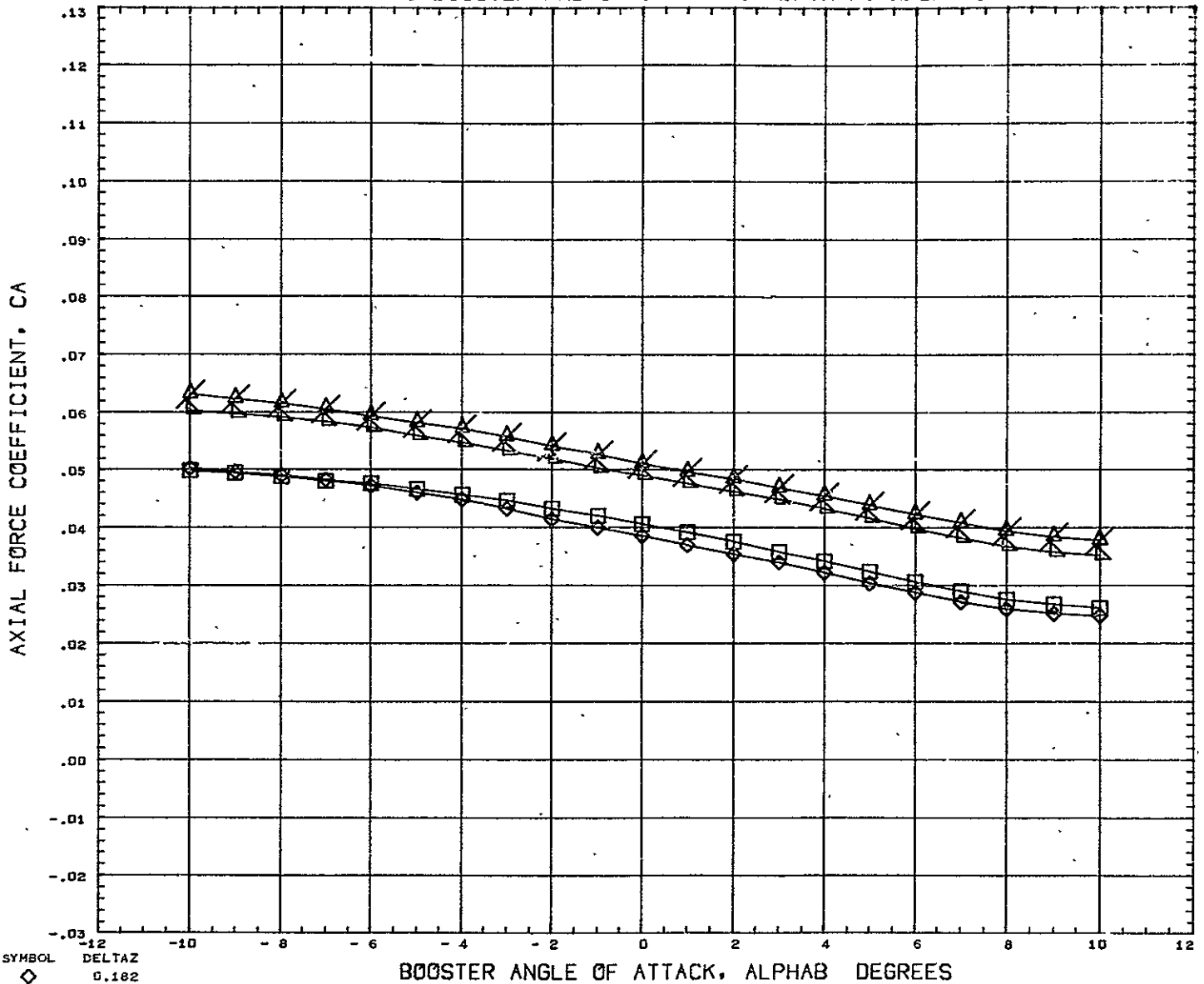

SYMBOL ◊ ◻ △	DELTAZ 0.182 0.228 0.352 10.000	PARAMETRIC VALUES BSTFOW 56.000 ORBPOW 100.000 DELTAX 0.352 ALPHAI - 10.000 MACH 5.010 ELVBST 0.000 ELVORB 0.000 BETA 0.000	REFERENCE INFORMATION REFS 23.6890 SQ IN REFL 4.1930 IN REFB 6.5000 IN XMRF 4.9170 IN YMRP 0.0000 IN ZMRP 1.3900 IN SCALE 0.0055
REFERENCE FILE			

# AEDC VA 1163 MDAC BOOSTER AND ORBITER TEST DATA AT MACH NUMBER 5

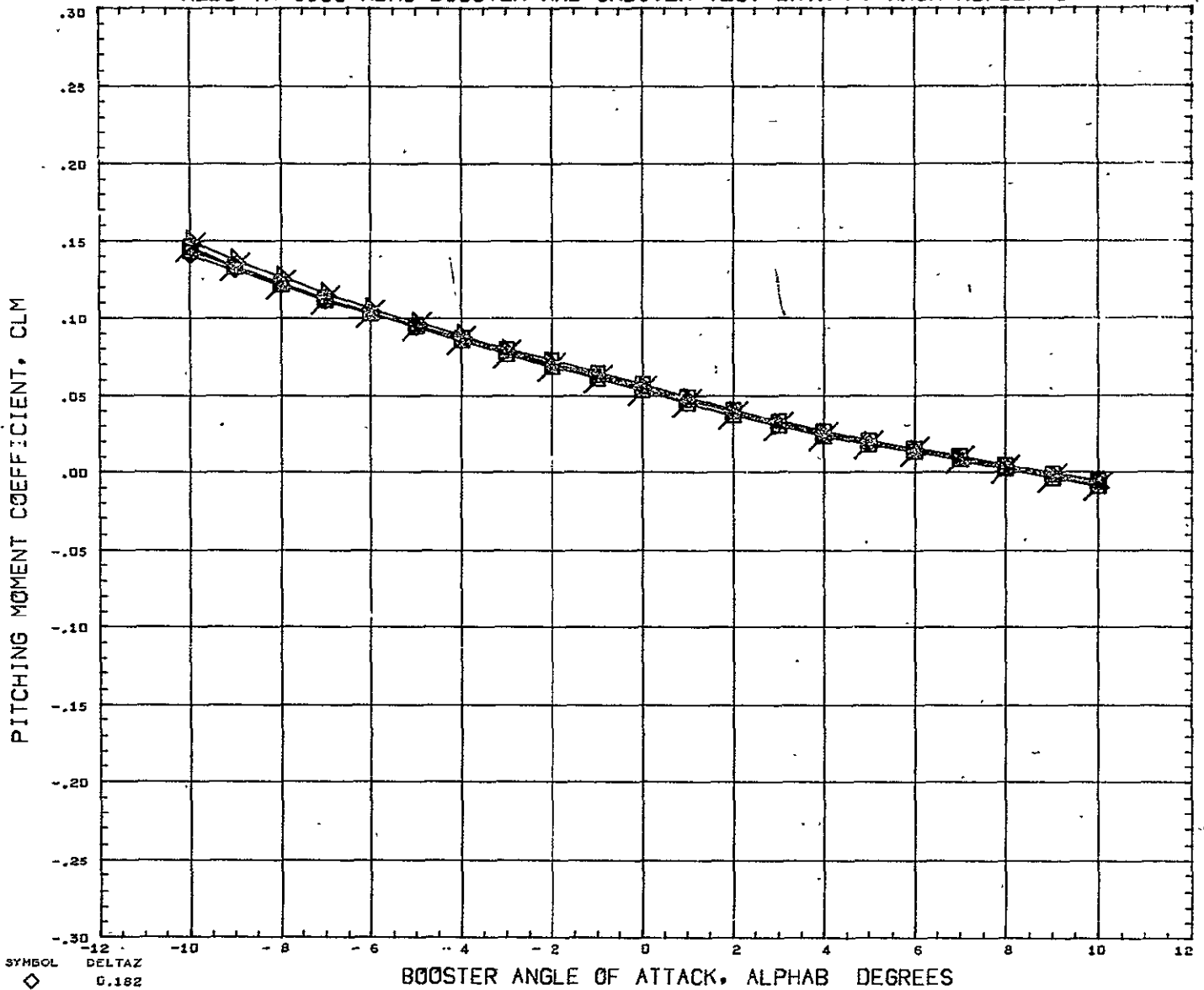

SYMBOL 	DELTAZ 0.182 0.228 0.352 0.599 10.000	PARAMETRIC VALUES BSTFOW 50.000 ORBPOW 100.000 DELTAX 0.521 ALPHAI - 10.000 MACH 5.016 ELVBST 0.000 ELVORB 0.000 BETA 0.000	REFERENCE INFORMATION REFS 23.6890 SQ IN REFL 4.1930 IN REFB 6.5000 IN XMRF 4.9170 IN YMRP 0.0000 IN ZMRP 1.3900 IN SCALE 0.0055
------------	--	---	---

REFERENCE FILE

# AEDC VA 1163 MDAC BOOSTER AND ORBITER TEST DATA AT MACH NUMBER 5

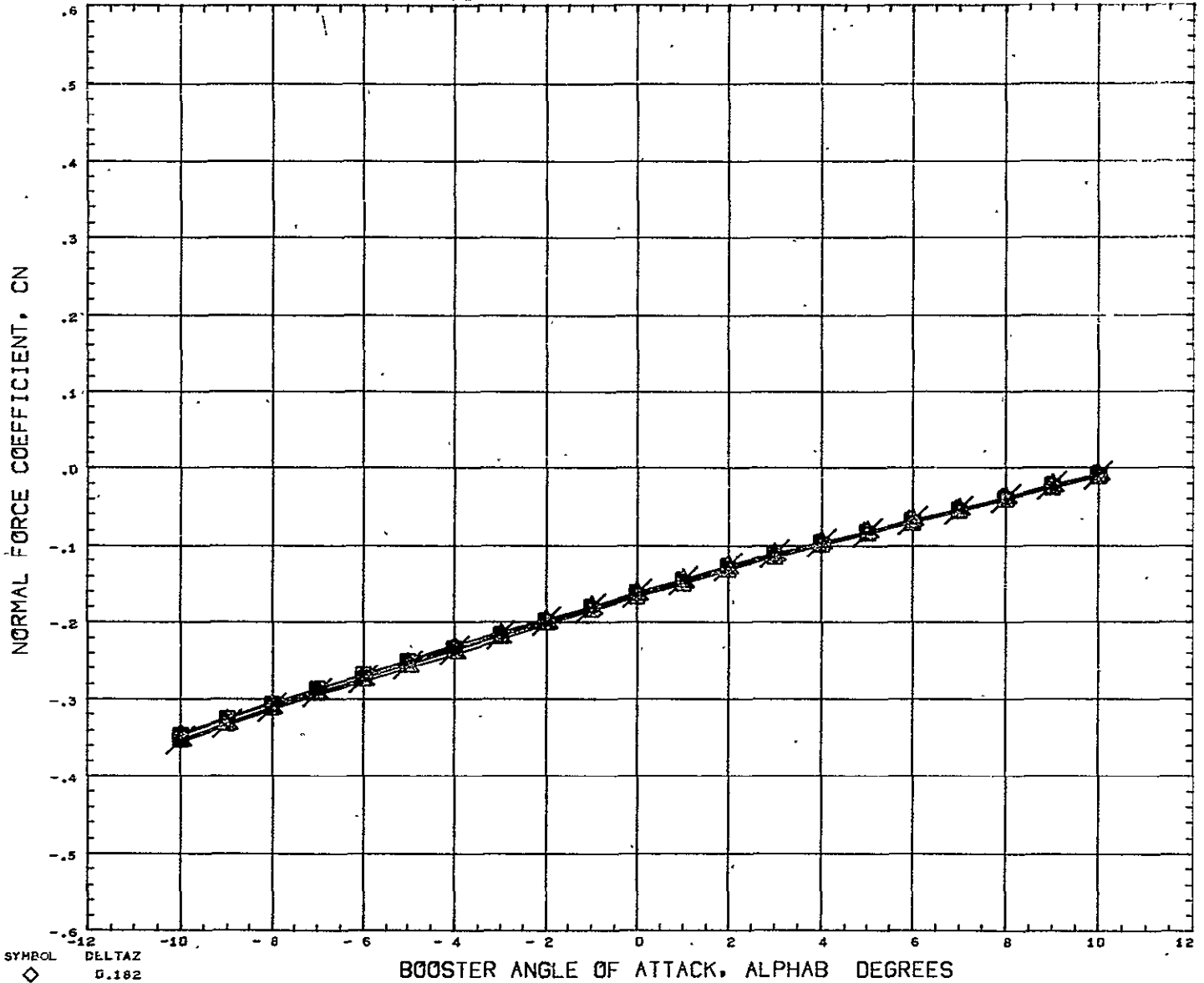

SYMBOL ◇ □ ▽	DELTAZ 0.182 0.228 0.352 0.599 10.000	PARAMETRIC VALUES BSTPOW 50.000 ORBPOW 100.000 DELTAX 0.521 ALPHAI - 10.000 MACH 5.010 ELVBST 0.000 ELVORB 0.000 BETA 0.100	REFERENCE INFORMATION REFS 23.6890 SQ IN REFL 4.1930 IN REFB 6.5000 IN XHRF 4.9170 IN YHRF 0.0000 IN ZHRF 1.3900 IN SCALE 0.0055
REFERENCE FILE			



# AEDC VA 1163 MDAC BOOSTER AND ORBITER TEST DATA AT MACH NUMBER 5

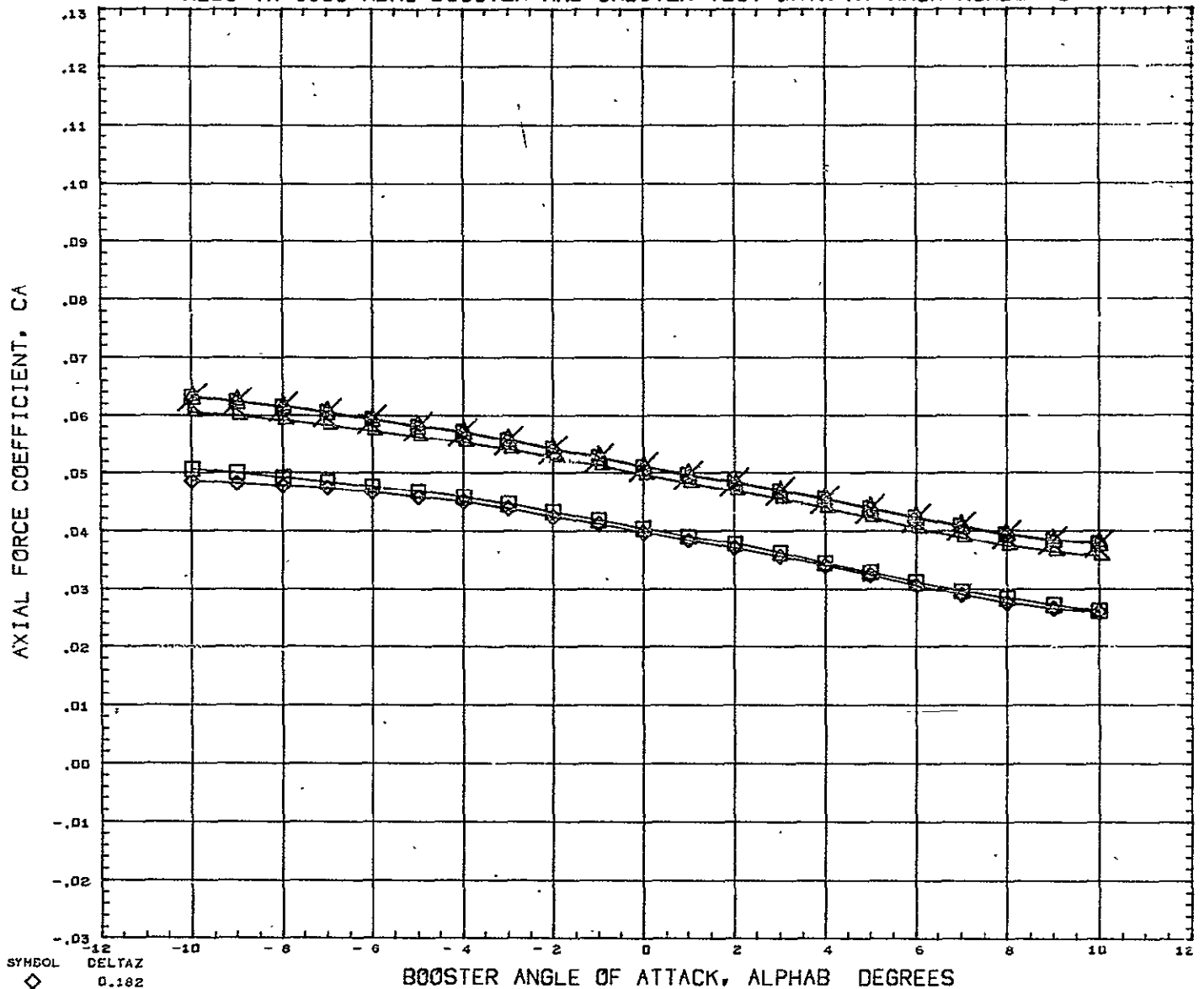

SYMBOL ◊ □ x	DELTAZ 0.182 0.228 0.352 0.599 10.000	PARAMETRIC VALUES BSTFOW 50.000 ORBPOW 100.000 DELTAX 0.521 ALPHAI - 10.000 MACH 5.010 ELVBST 0.000 ELVORB 0.000 BETA 0.000	REFERENCE INFORMATION REFS 23.6890 SQ IN REFL 4.1938 IN REFB 6.5000 IN XMRP 4.9170 IN YHRF 0.000J IN ZMRP 1.3900 IN SCALE 0.0055
REFERENCE FILE			

# AEDC VA 1163 MDAC BOOSTER AND ORBITER TEST DATA AT MACH NUMBER 5

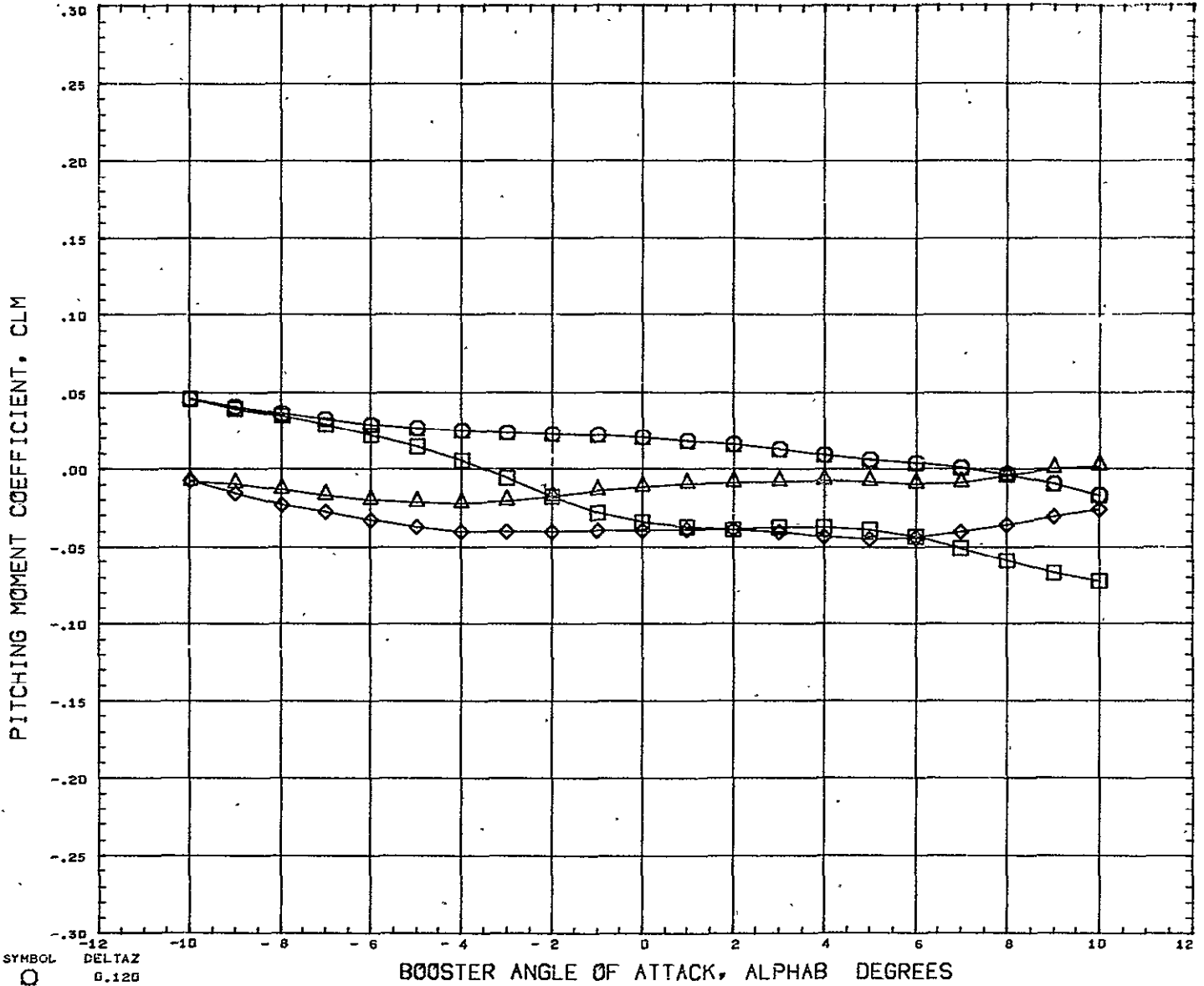

SYMBOL DELTA Z  
 ○ 0.120  
 △ 0.151  
 ◇ 0.182  
 □ 0.228

**PARAMETRIC VALUES**  
 BSTPOW 0.000 ORBPOW 0.000  
 DELTAX - 0.391 ALPHAI 0.000  
 MACH 5.020 ELVBST 0.000  
 ELVORB 0.000 BETA 0.050

**REFERENCE INFORMATION**  
 REFS 23.5890 SQ IN  
 REFL 4.1930 IN  
 REFB 6.5000 IN  
 XMRP 4.9170 IN  
 YMRP 0.0000 IN  
 ZMRP 1.3900 IN  
 SCALE 0.0055

REFERENCE FILE

# AEDC VA 1163 MDAC BOOSTER AND ORBITER TEST DATA AT MACH NUMBER 5

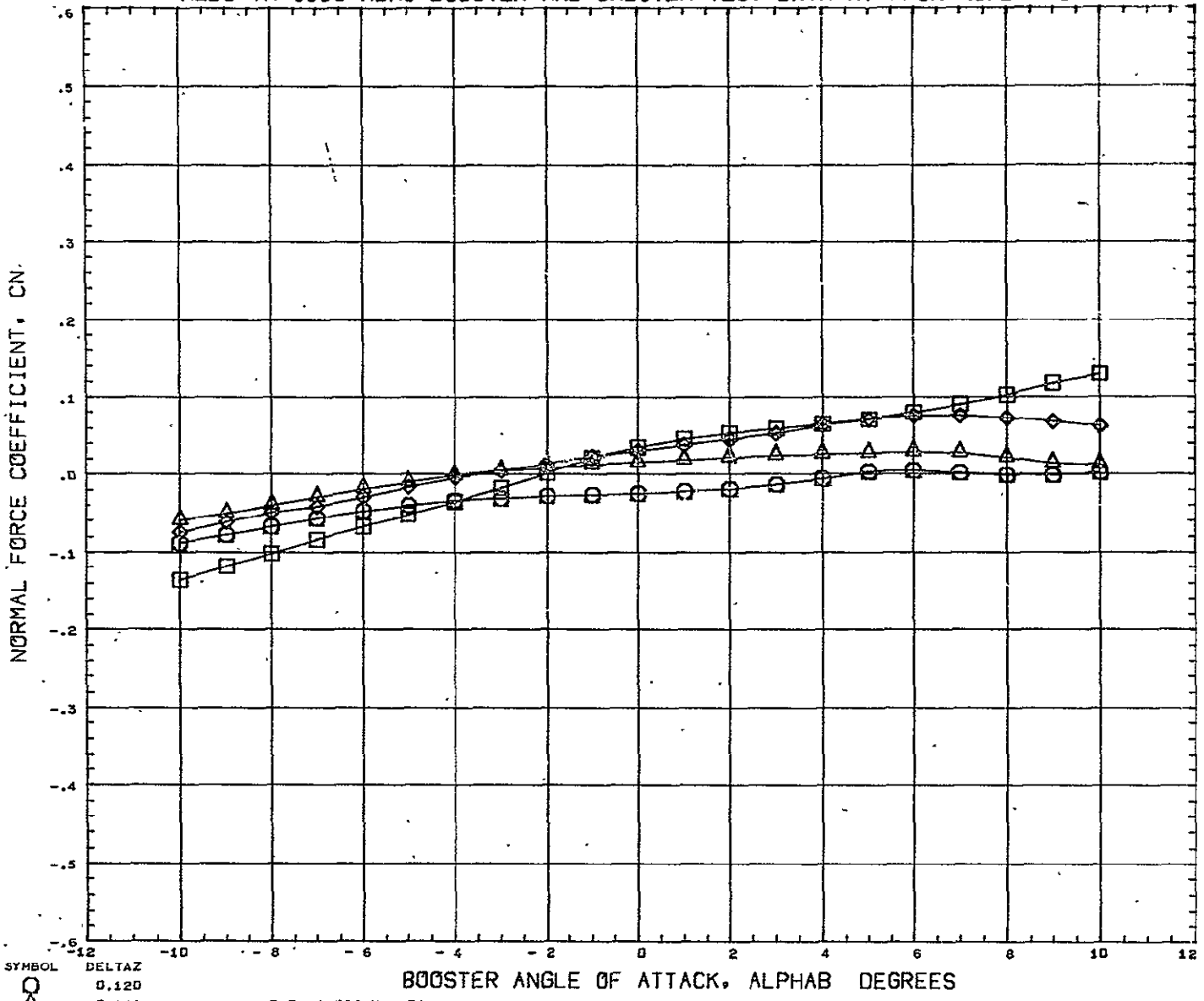

SYMBOL ○ △ ◇ □	DELTA Z 0.120 0.151 0.182 0.228	<table border="0" style="width: 100%;"> <tr> <th colspan="4" style="text-align: left; padding-left: 20px;">PARAMETRIC VALUES</th> </tr> <tr> <td style="padding-right: 20px;">BSTPCW</td> <td>0.000</td> <td style="padding-right: 20px;">ORBPCW</td> <td>0.000</td> </tr> <tr> <td>DELTA X</td> <td>0.391</td> <td>ALPHA I</td> <td>0.000</td> </tr> <tr> <td>MACH</td> <td>5.020</td> <td>ELVBST</td> <td>0.000</td> </tr> <tr> <td>ELVORB</td> <td>0.000</td> <td>BETA</td> <td>0.000</td> </tr> </table>	PARAMETRIC VALUES				BSTPCW	0.000	ORBPCW	0.000	DELTA X	0.391	ALPHA I	0.000	MACH	5.020	ELVBST	0.000	ELVORB	0.000	BETA	0.000	<table border="0" style="width: 100%;"> <tr> <th colspan="3" style="text-align: left;">REFERENCE INFORMATION</th> </tr> <tr> <td>REFS</td> <td>23.6890</td> <td>SQ IN</td> </tr> <tr> <td>REFL</td> <td>4.1930</td> <td>IN</td> </tr> <tr> <td>REFB</td> <td>6.5000</td> <td>IN</td> </tr> <tr> <td>XMRP</td> <td>4.9170</td> <td>IN</td> </tr> <tr> <td>YMRP</td> <td>0.0000</td> <td>IN</td> </tr> <tr> <td>ZMRP</td> <td>1.3900</td> <td>IN</td> </tr> <tr> <td>SCALE</td> <td>0.0055</td> <td></td> </tr> </table>	REFERENCE INFORMATION			REFS	23.6890	SQ IN	REFL	4.1930	IN	REFB	6.5000	IN	XMRP	4.9170	IN	YMRP	0.0000	IN	ZMRP	1.3900	IN	SCALE	0.0055	
PARAMETRIC VALUES																																															
BSTPCW	0.000	ORBPCW	0.000																																												
DELTA X	0.391	ALPHA I	0.000																																												
MACH	5.020	ELVBST	0.000																																												
ELVORB	0.000	BETA	0.000																																												
REFERENCE INFORMATION																																															
REFS	23.6890	SQ IN																																													
REFL	4.1930	IN																																													
REFB	6.5000	IN																																													
XMRP	4.9170	IN																																													
YMRP	0.0000	IN																																													
ZMRP	1.3900	IN																																													
SCALE	0.0055																																														

# AEDC VA 1163 MDAC BOOSTER AND ORBITER TEST DATA AT MACH NUMBER 5

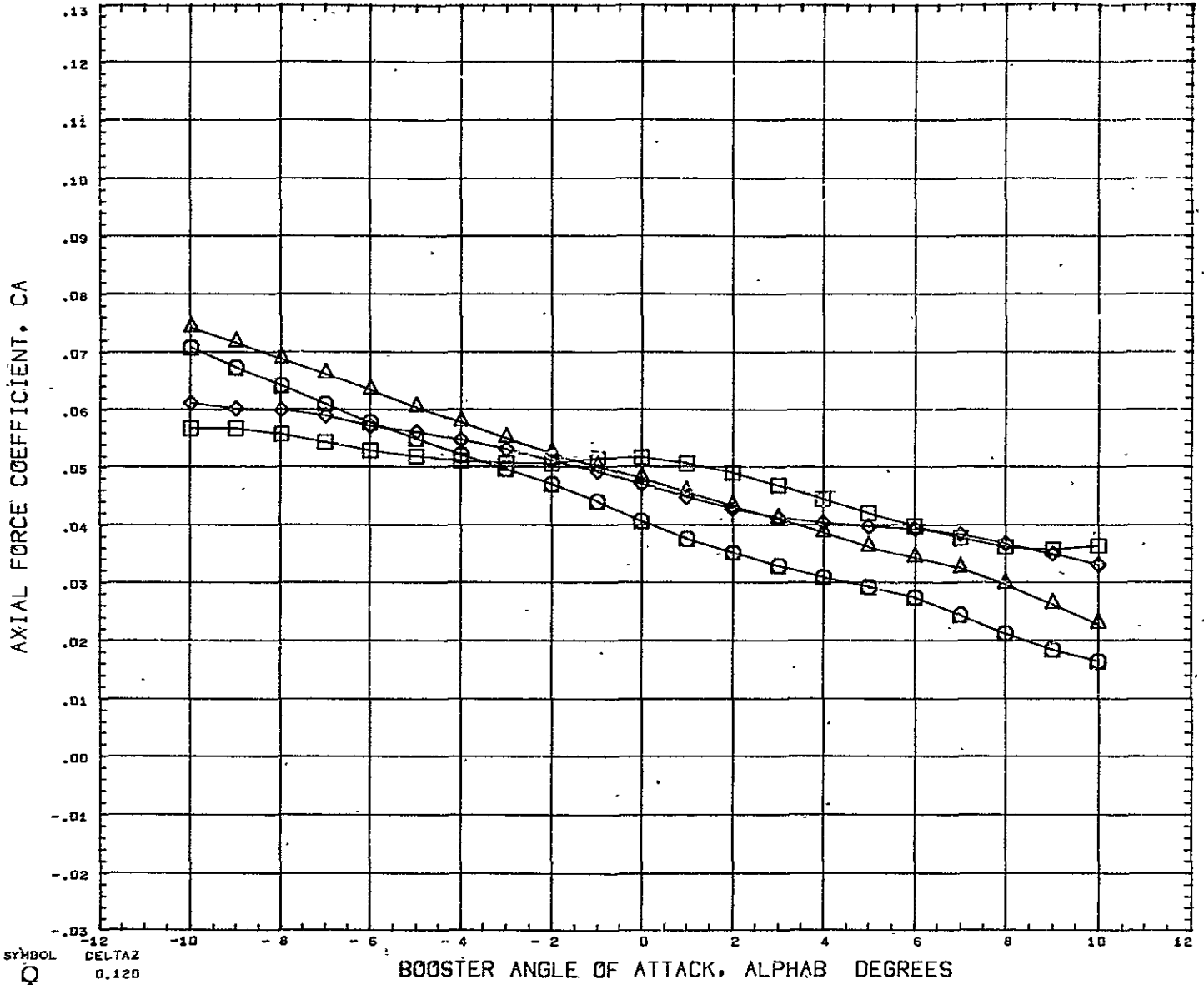

SYMBOL  
 ○  
 ◇  
 □  
 △

DELTA Z  
 0.120  
 0.151  
 0.182  
 0.228

PARAMETRIC VALUES  
 BSTFOW 0.000 ORBFOV 0.000  
 DELTAX - 0.391 ALPHAI 0.000  
 MACH 5.020 ELVBST 0.000  
 ELVORB 0.000 BETA 0.000

REFERENCE INFORMATION  
 REFS 23.6390 SQ IN  
 REFL 4.1930 IN  
 REFB 6.5000 IN  
 XMRP 4.9170 IN  
 YMRP 0.0000 IN  
 ZMRP 1.3900 IN  
 SCALE 0.0055

REFERENCE FILE

# AEDC VA 1163 MDAC BOOSTER AND ORBITER TEST DATA AT MACH NUMBER 5

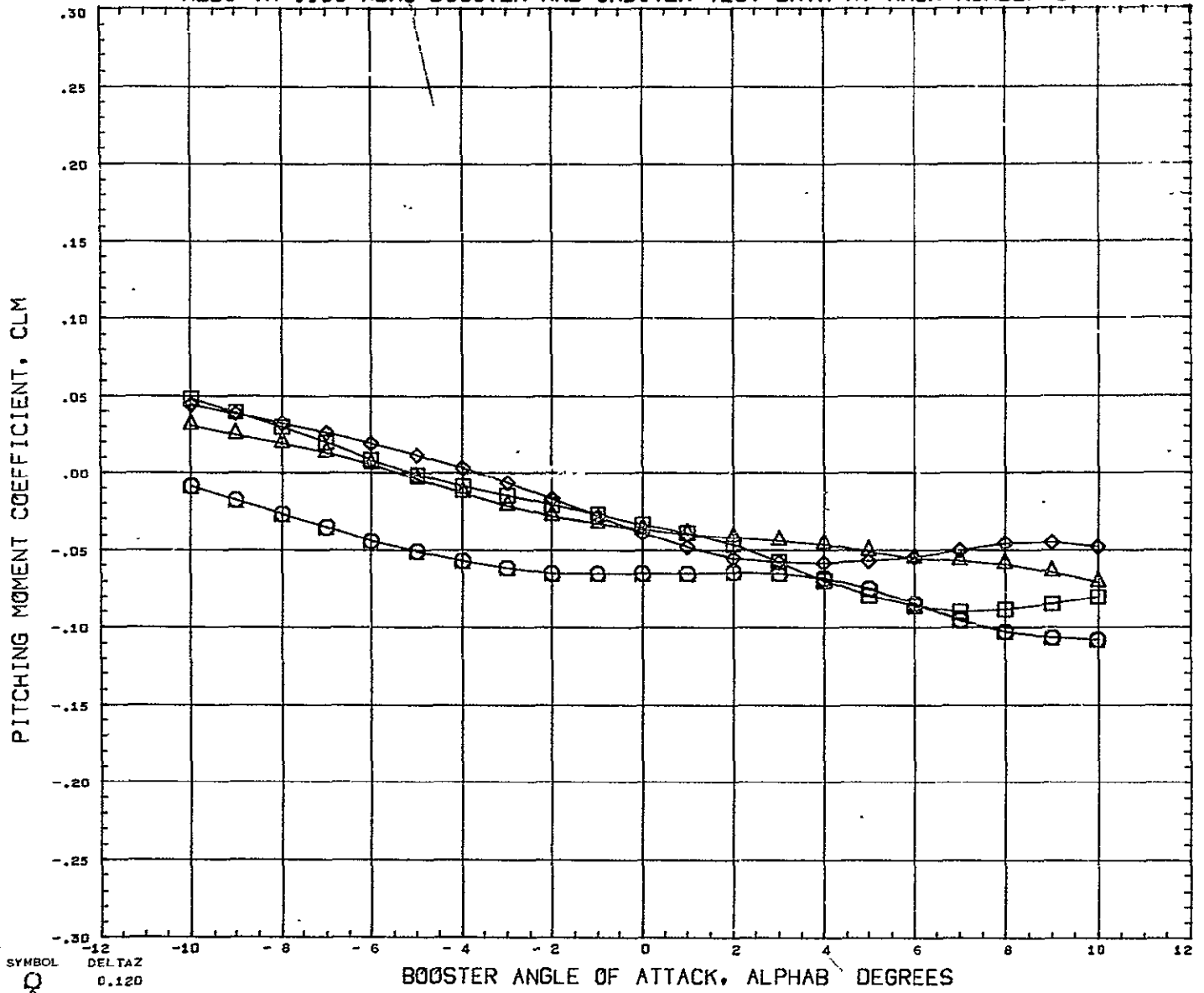

SYMBOL ◻ ◻ ◻ ◻	DELTAX 0.120 0.151 0.182 0.228	PARAMETRIC VALUES BSTPOW    0.000    ORBPOW    0.000 DELTAX    - 0.143    ALPHAI    0.000 MACH       5.020    ELVBST    0.000 ELVORB    0.000    BETA       0.000	REFERENCE INFORMATION REFS       23.6890    SQ IN REFL       4.1930    IN REFB       6.5000    IN XHRF       4.9170    IN YHRF       0.0000    IN ZHRF       1.3900    IN SCALE      0.0055
REFERENCE FILE			

# AEDC VA 1163 MDAC BOOSTER AND ORBITER TEST DATA AT MACH NUMBER 5

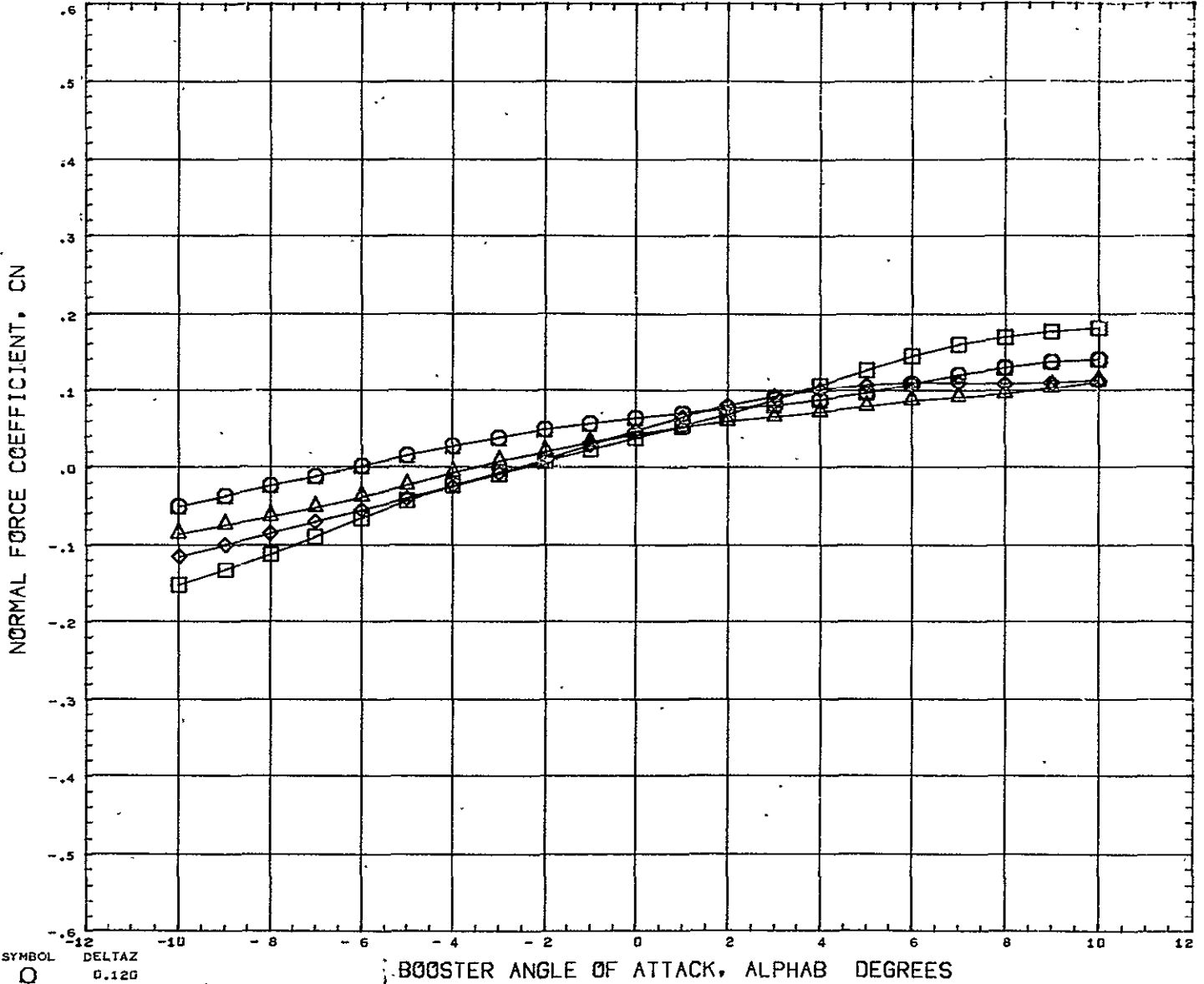

SYMBOL ○ △ ◇ □	DELTAZ 0.120 0.151 0.182 0.228	PARAMETRIC VALUES BSTPOW 0.000 ORBPOW 0.000 DELTAX - 0.143 ALPHAI 0.000 MACH 5.020 ELVBST 0.000 ELVORB 0.000 BETA 0.000	REFERENCE INFORMATION REFS 23.6890 SQ IN REFL 4.1930 IN REFB 6.5000 IN XMRP 4.9170 IN YMRP 0.0000 IN ZMRP 1.3900 IN SCALE 0.0055
----------------------------	--	---	---

!! REFERENCE FILE

# AEDC VA 1163 MDAC BOOSTER AND ORBITER TEST DATA AT MACH NUMBER 5

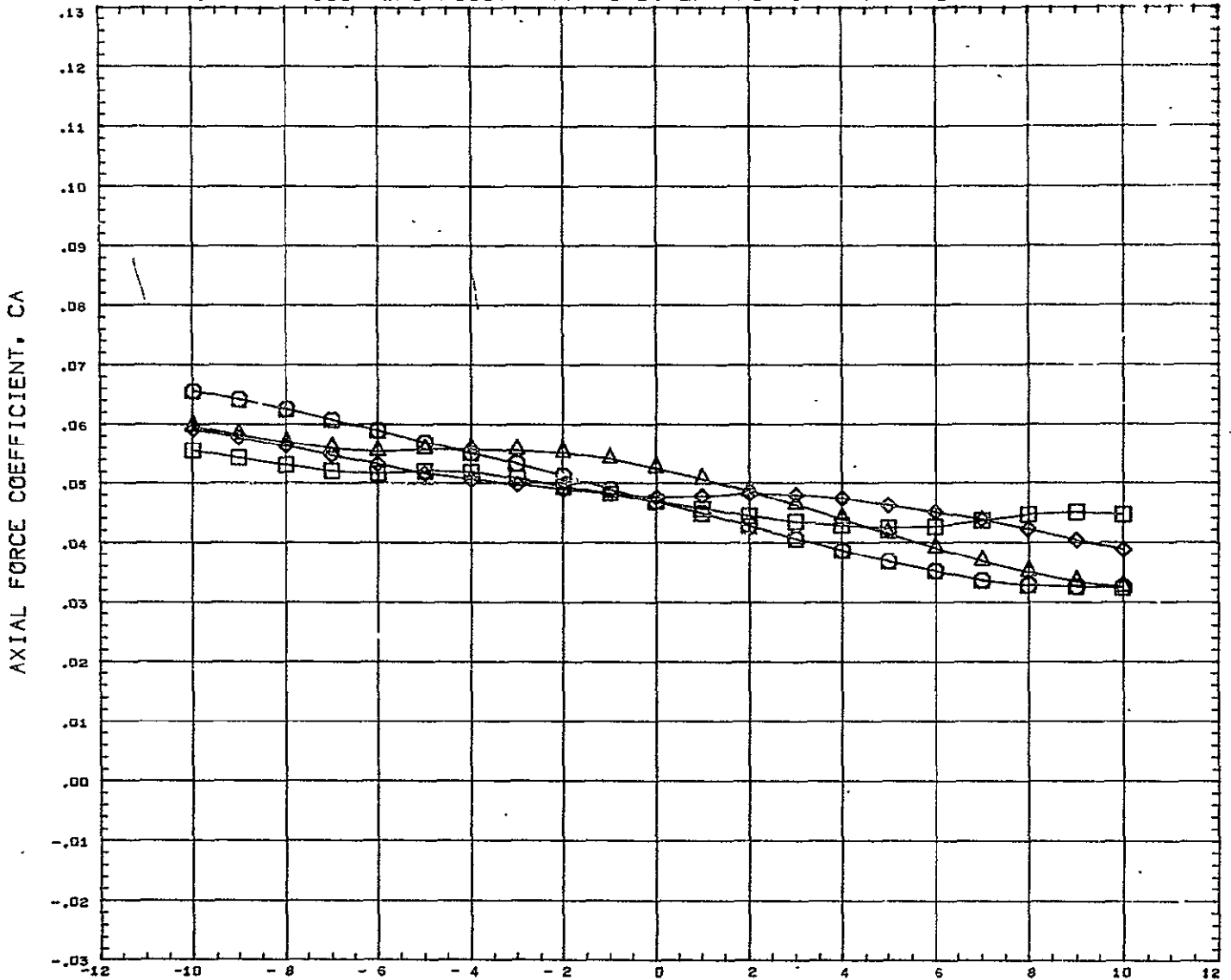

SYMBOL ○ △ ◇ □	DELTA Z 0.120 0.151 0.182 0.228	PARAMETRIC VALUES .BSTPOW 0.000 ORBPOW 0.000 DELTAX - 0.143 ALPHAI 0.000 MACH 5.020 ELVBST 0.000 ELVORB 0.000 BETA 0.000	REFERENCE INFORMATION REFS 23.6890 SQ IN REFL 4.1930 IN REFB 6.5000 IN XMRF 4.8170 IN YMRF 0.0000 IN ZMRF 1.3900 IN SCALE 0.0055
REFERENCE FILE			

# AEDC VA 1163 MDAC BOOSTER AND ORBITER TEST DATA AT MACH NUMBER 5

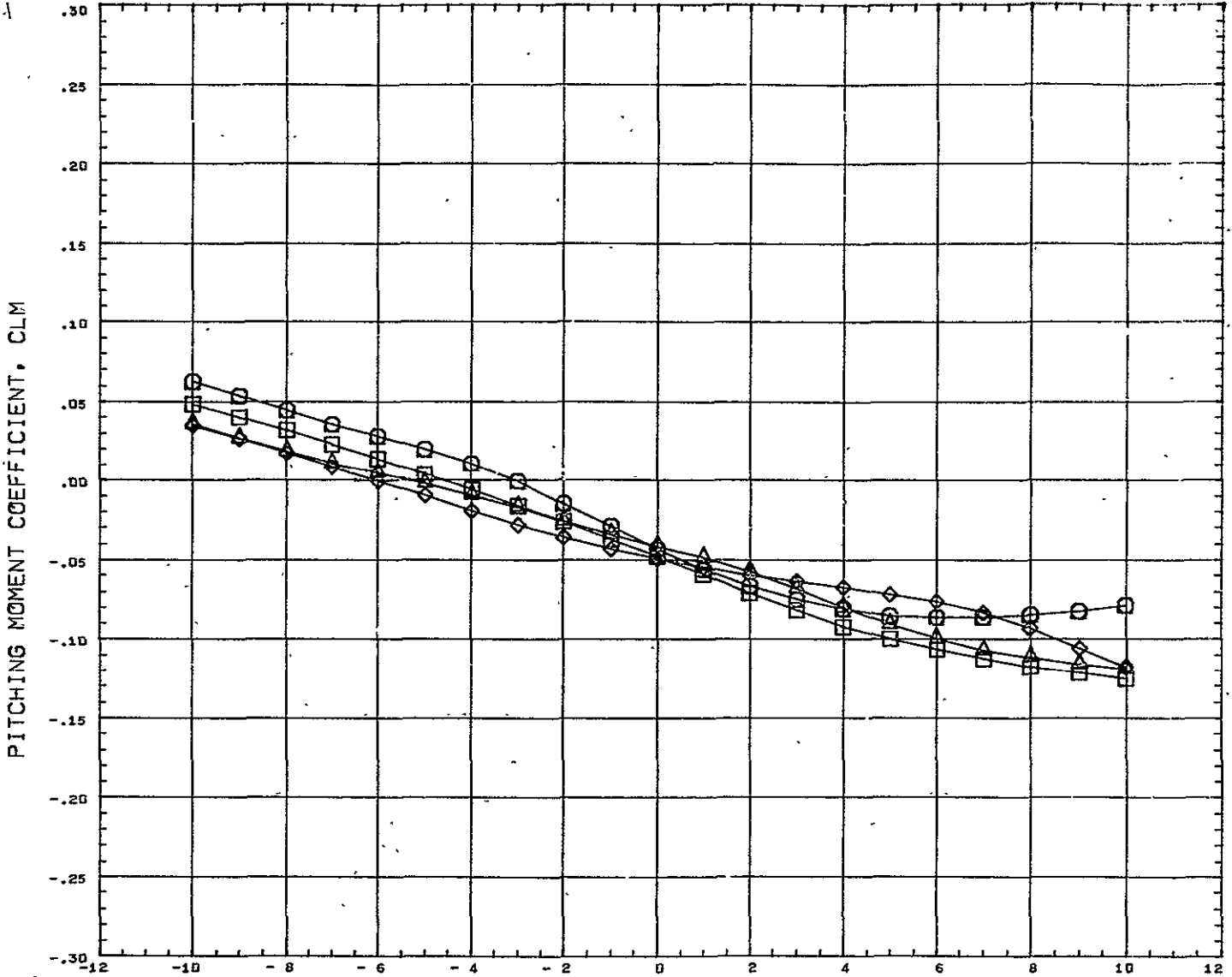

SYMBOL  
 ◊  
 △  
 ◻  
 ○

DELTA Z  
 0.120  
 0.151  
 0.182  
 0.228

PARAMETRIC VALUES  
 BSTFOW 0.000 ORBFOV 0.000  
 DELTAX 0.105 ALPHAI 0.000  
 MACH 5.020 ELVBST 0.000  
 ELVORB 0.000 BETA 0.000

REFERENCE INFORMATION  
 REFS 23.6890 SQ IN  
 REFL 4.1930 IN  
 REFB 6.5000 IN  
 XMRP 4.9170 IN  
 YMRP 0.0000 IN  
 ZMRP 1.3900 IN  
 SCALE 0.0055

REFERENCE FILE



# AEDC VA 1163 MDAC BOOSTER AND ORBITER TEST DATA AT MACH NUMBER 5

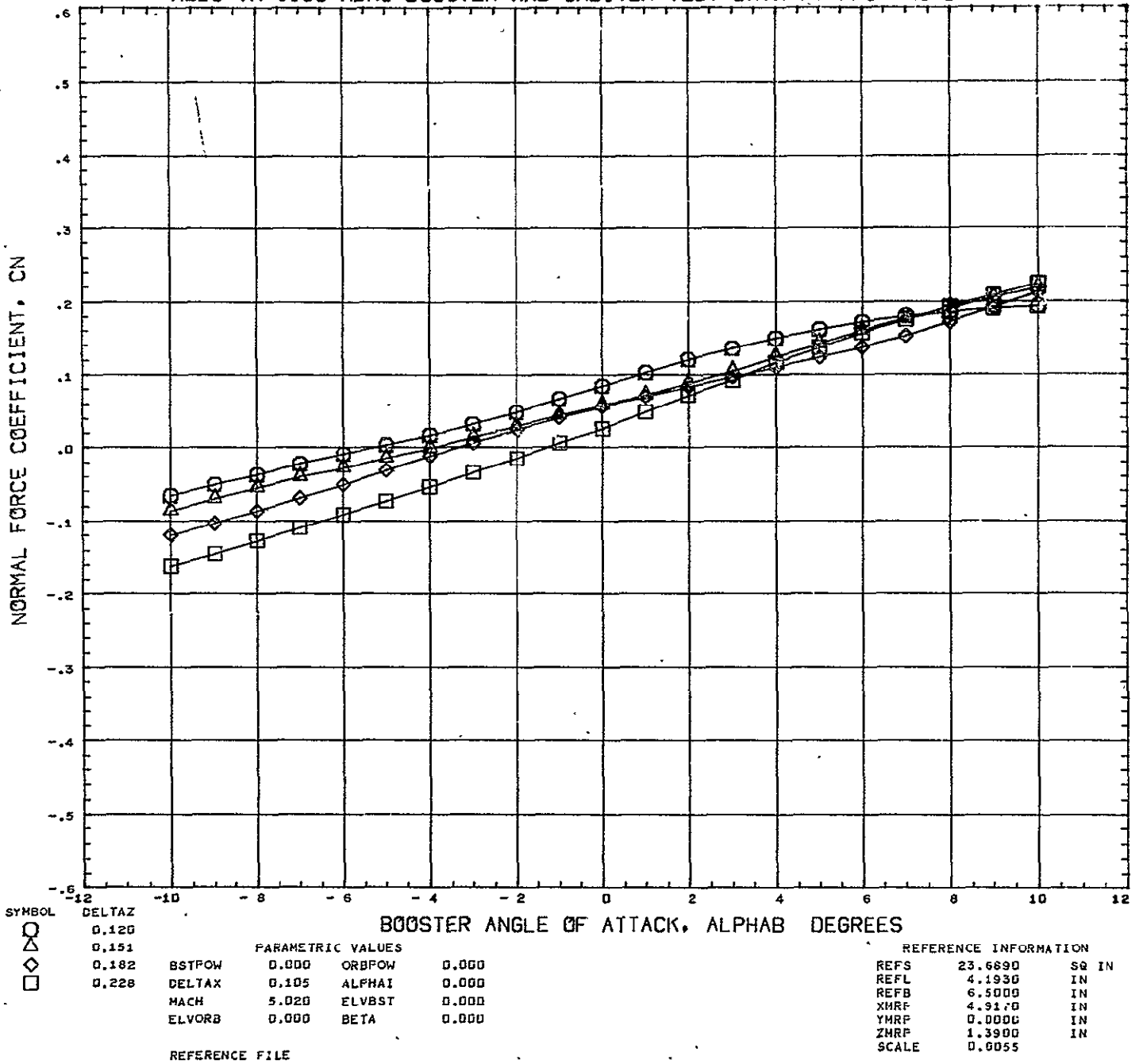

# AEDC VA 1163 MDAC BOOSTER AND ORBITER TEST DATA AT MACH NUMBER 5

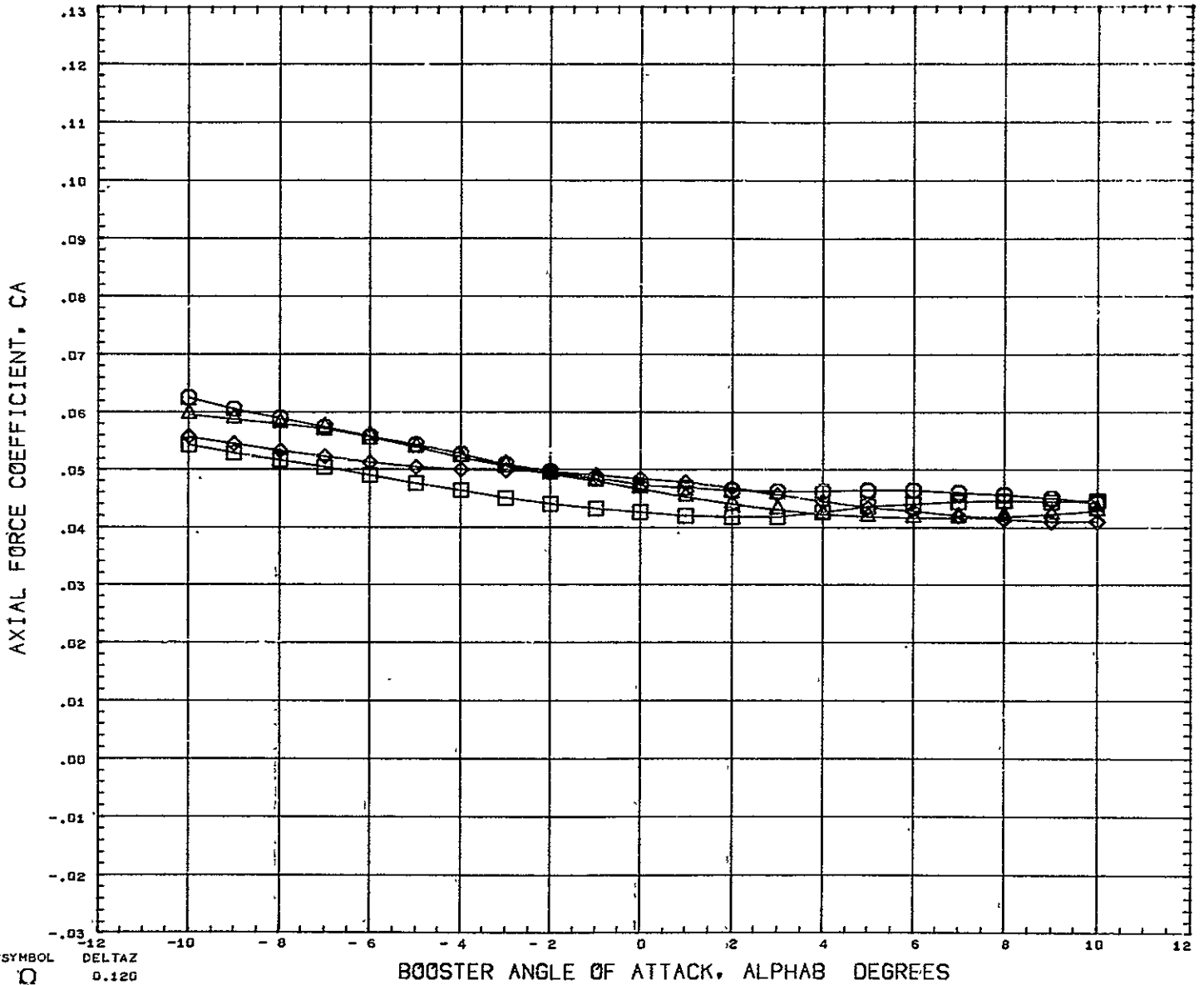

SYMBOL ○ △ ◇ □	DELTAZ 0.120 0.151 0.182 0.228	PARAMETRIC VALUES BSTFOW 0.000 ORBFOW 0.000 DELTAX 0.105 ALPHA1 0.000 MACH 5.020 ELVBST 0.000 ELVORB 0.000 BETA 0.000	REFERENCE INFORMATION REFS 23.6890 SQ IN REFL 4.1930 IN REFB 6.5000 IN XMRP 4.9170 IN YMRP 0.0000 IN ZMRP 1.3900 IN SCALE 0.0055
REFERENCE FILE			

# AEDC VA 1163 MDAC BOOSTER AND ORBITER TEST DATA AT MACH NUMBER 5

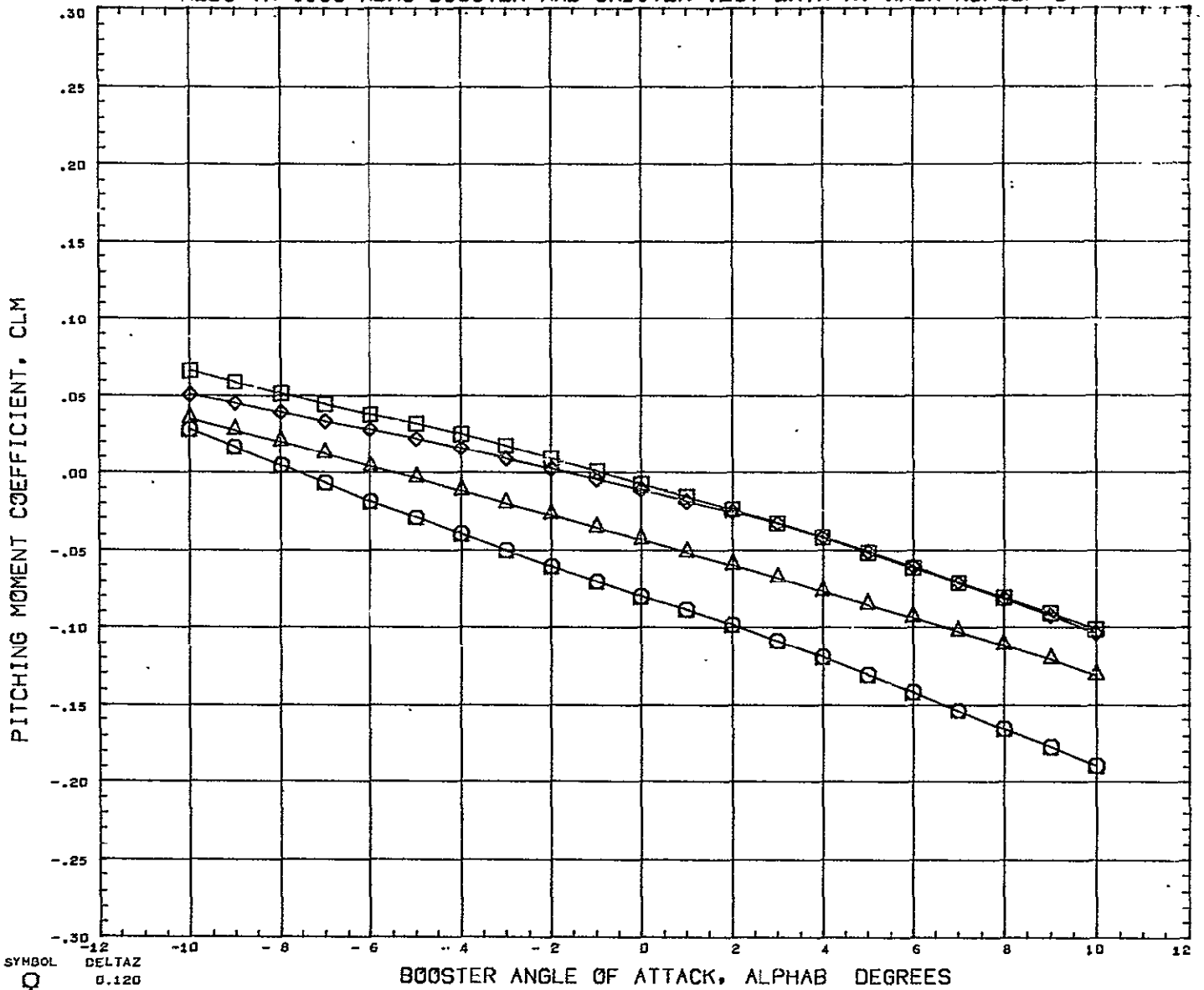

SYMBOL  
 ○ 0.120  
 △ 0.151  
 ◇ 0.182  
 □ 0.228

**PARAMETRIC VALUES**  
 BSTPOW 0.000 ORBPOW 0.000  
 DELTAX 0.521 ALPHAI 0.000  
 MACH 5.026 ELVBST 0.000  
 ELVORB 0.000 BETA 0.000

**REFERENCE INFORMATION**  
 REFS 23.6896 SQ IN  
 REFL 4.1930 IN  
 REFB 6.5000 IN  
 XMRF 4.9170 IN  
 YMRF 0.0000 IN  
 ZMRF 1.3900 IN  
 SCALE 0.0055

REFERENCE FILE

# AEDC VA 1163 MDAC BOOSTER AND ORBITER TEST DATA AT MACH NUMBER 5

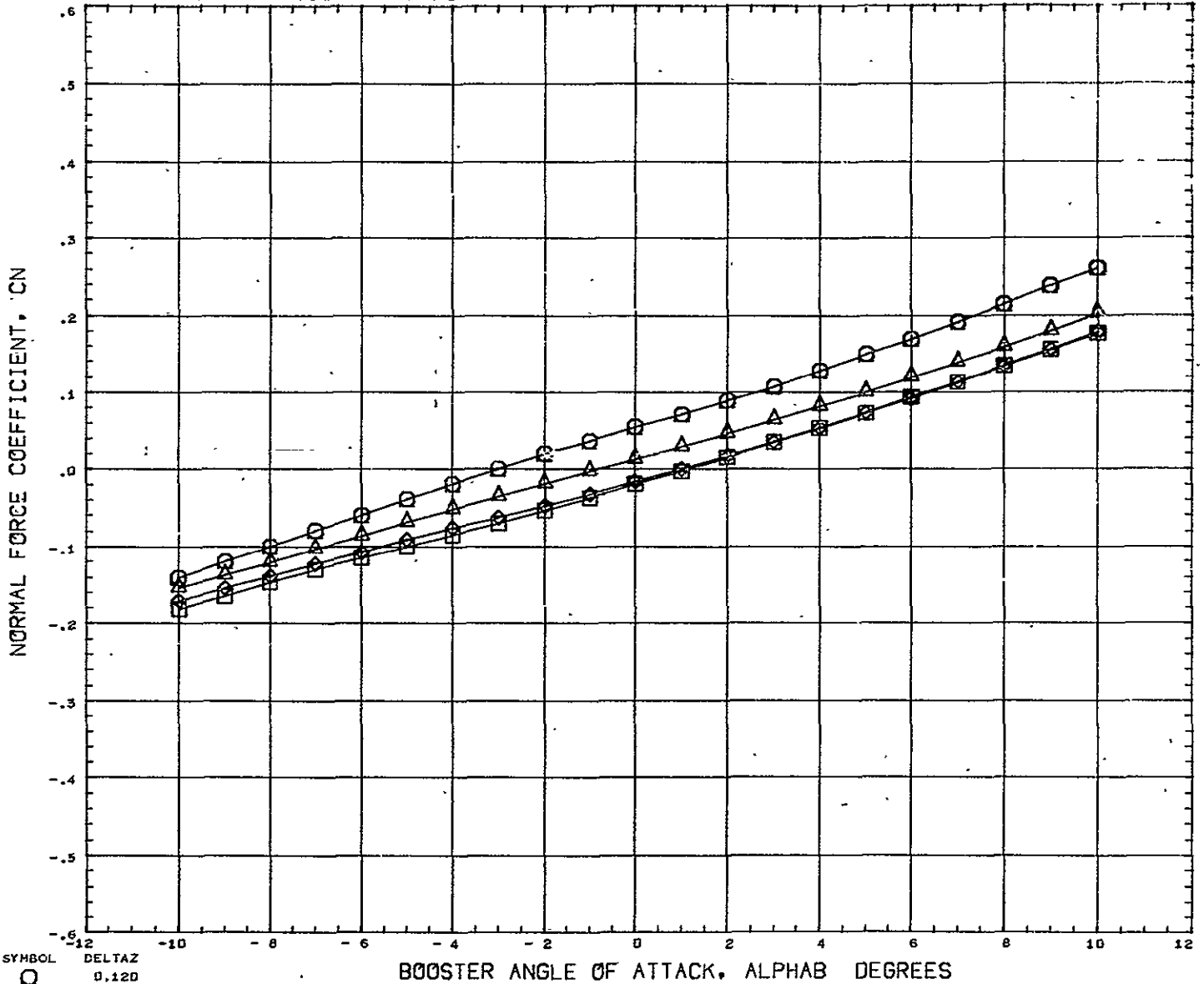

SYMBOL ○ △ ◇ □	DELTAX 0.120 0.151 0.182 0.228	<b>PARAMETRIC VALUES</b> BSTFOW    0.000    ORBPOW    0.000 DELTAX    0.521    ALPHAI    0.000 MACH      5.020    ELVBST    0.000 ELVORB    0.000    BETA      0.000	<b>REFERENCE INFORMATION</b> REFS      23.6690    SQ IN REFL      4.1930    IN REFB      6.5000    IN XMRP      4.9170    IN YMRP      0.0000    IN ZMRP      1.3900    IN SCALE     0.0055
REFERENCE FILE			

AEDC VA 1163 MDAC BOOSTER AND ORBITER TEST DATA AT MACH NUMBER 5

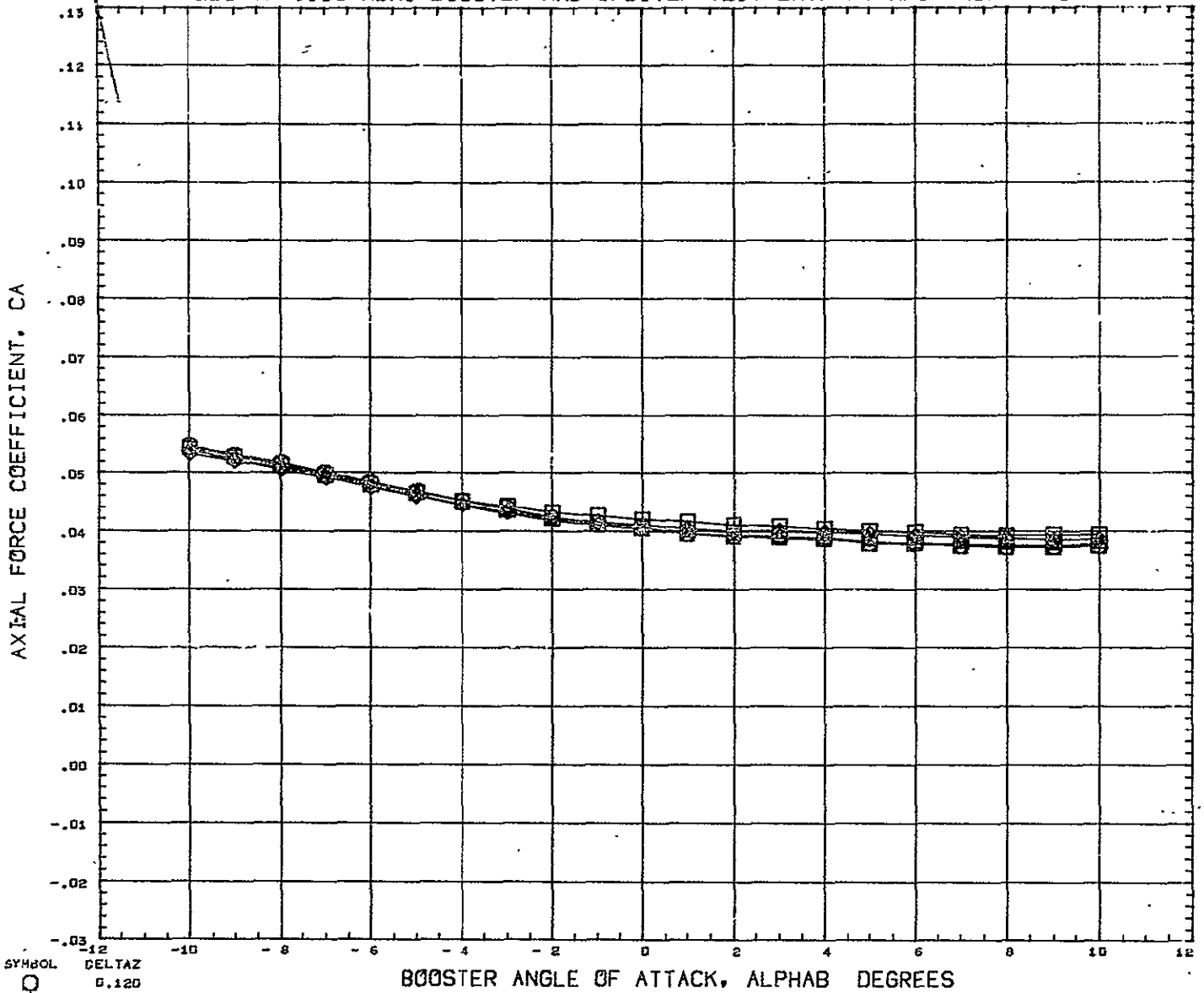

SYMBOL  
 ○  
 ◇  
 □

DELTA Z  
 0.120  
 0.151  
 0.182  
 0.228

PARAMETRIC VALUES  
 BSTPOW 0.000 ORBPOW 0.000  
 DELTAX 0.521 ALPHAI 0.000  
 MACH 5.020 ELVBST 0.000  
 ELVORB 0.000 BETA 0.000

REFERENCE INFORMATION  
 REFS 23.6890 SQ IN  
 REFL 4.1930 IN  
 REFB 6.5000 IN  
 XMRP 4.9170 IN  
 YMRP 0.0000 IN  
 ZMRP 1.3900 IN  
 SCALE 0.0055

REFERENCE FILE

# AEDC VA 1163 MDAC BOOSTER AND ORBITER TEST DATA AT MACH NUMBER 5

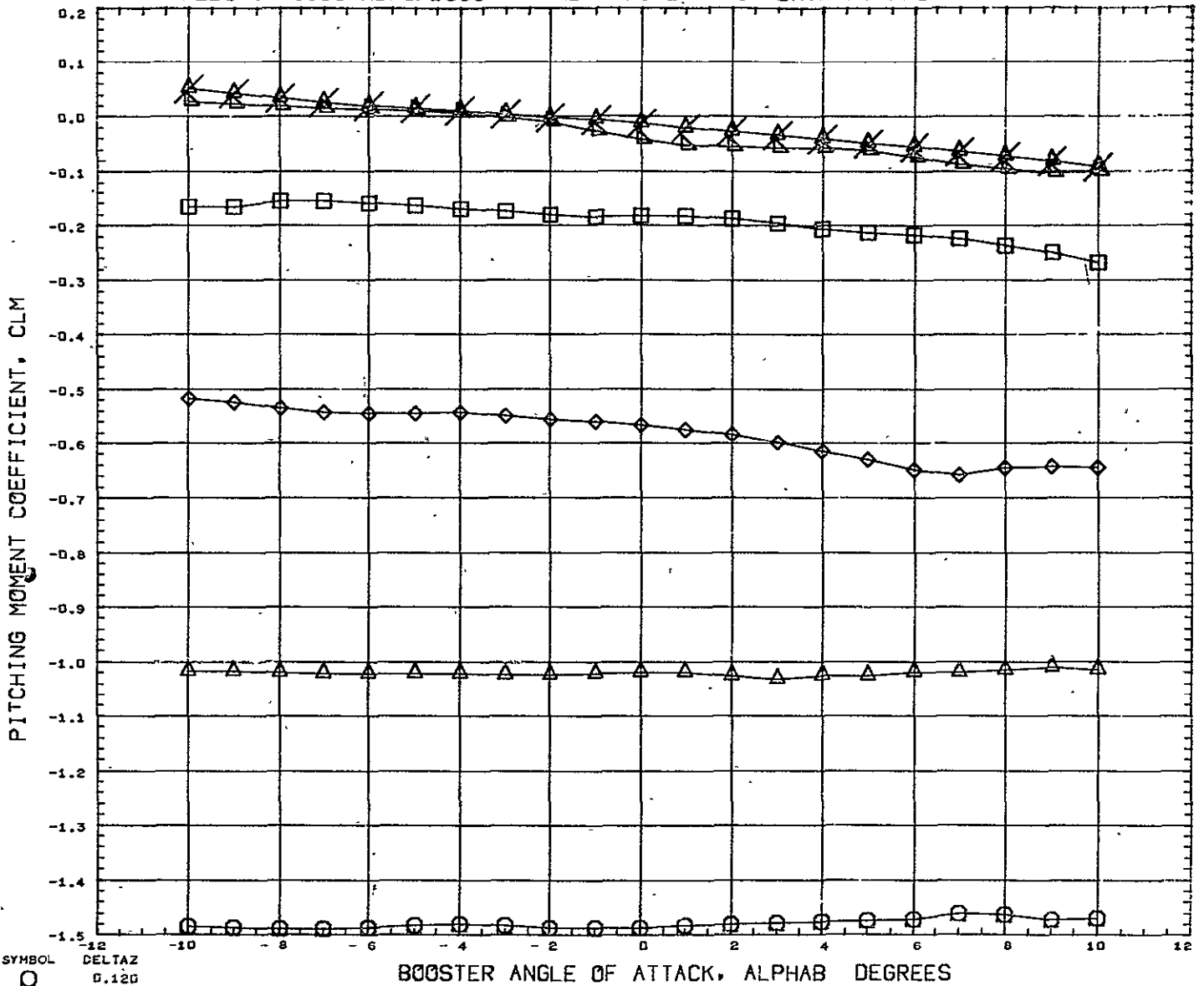

SYMBOL ○ ◇ □ ▲ ▼	DELTAZ 0.120 0.151 0.182 0.228 0.352 10.000	PARAMETRIC VALUES BSTPOW 100.000 ORBPOW 100.000 DELTAX - 0.391 ALPHAI 0.000 MACH 5.010 ELVBST 0.000 ELVORB 0.000 BETA 0.000	REFERENCE INFORMATION REFS 23.6890 SQ IN REFL 4.1930 IN REFB 6.5000 IN XMRP 4.9170 IN YMRP 0.0000 IN ZMRP 1.3900 IN SCALE 0.0055
---------------------------------	---	---	---

REFERENCE FILE

# AEDC VA 1163 MDAC BOOSTER AND ORBITER TEST DATA AT MACH NUMBER 5

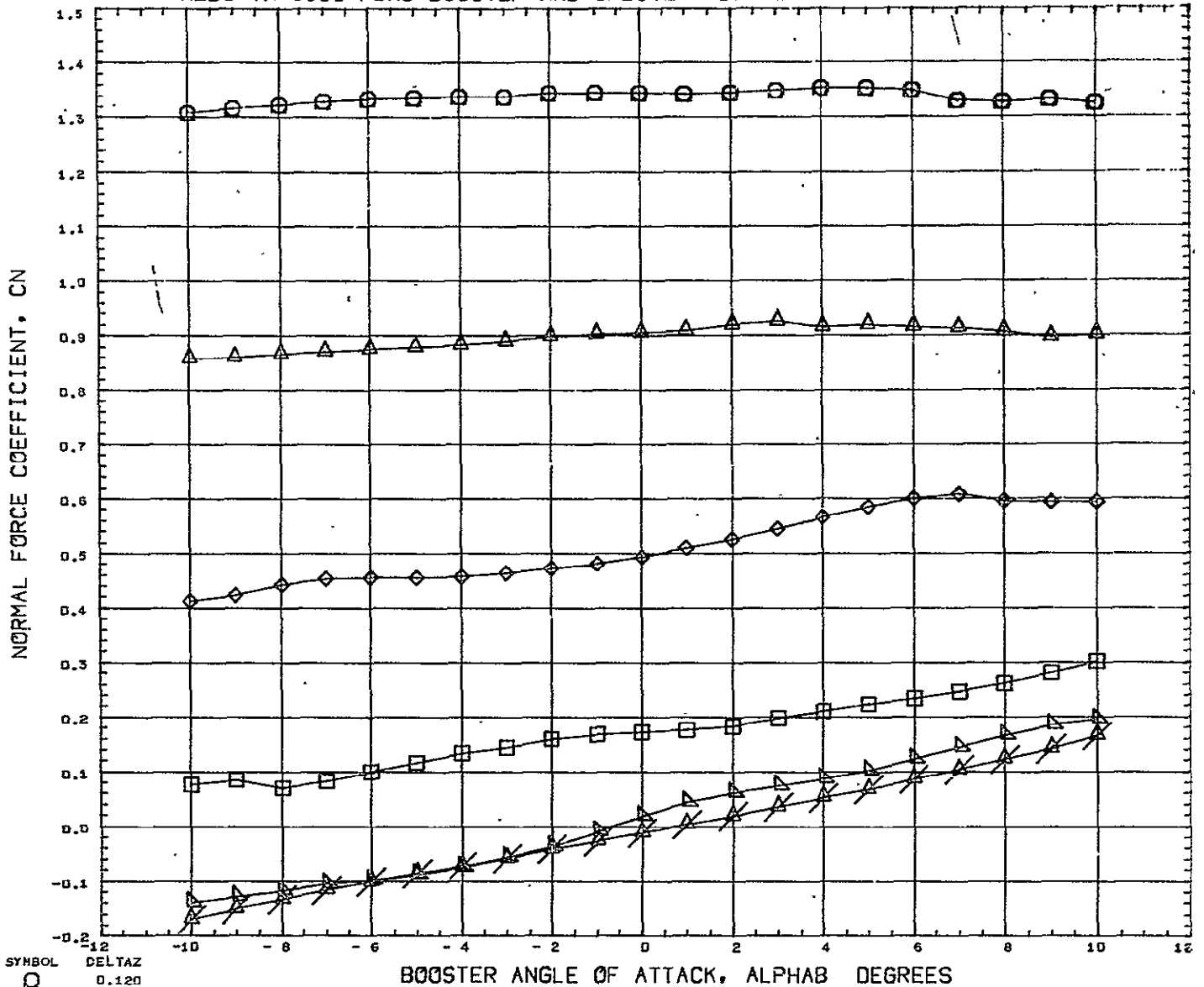

SYMBOL ○ ◇ □ △ △ △	DELTAZ 0.120 0.151 0.182 0.228 0.352 10.000	PARAMETRIC VALUES BSTPOW 100.000 ORBPOW 100.000 DELTAX - 0.391 ALPHAI 0.000 MACH 5.010 ELVBST 0.000 ELVORB 0.000 BETA 0.090	REFERENCE INFORMATION REFS 23.6890 SQ IN REFL 4.1930 IN REFB 6.5000 IN XMRP 4.9170 IN YMRP 0.0000 IN ZMRP 1.3900 IN SCALE 0.0055
--------------------------------------	---	---	---

REFERENCE FILE

# AEDC VA 1163 MDAC BOOSTER AND ORBITER TEST DATA AT MACH NUMBER 5

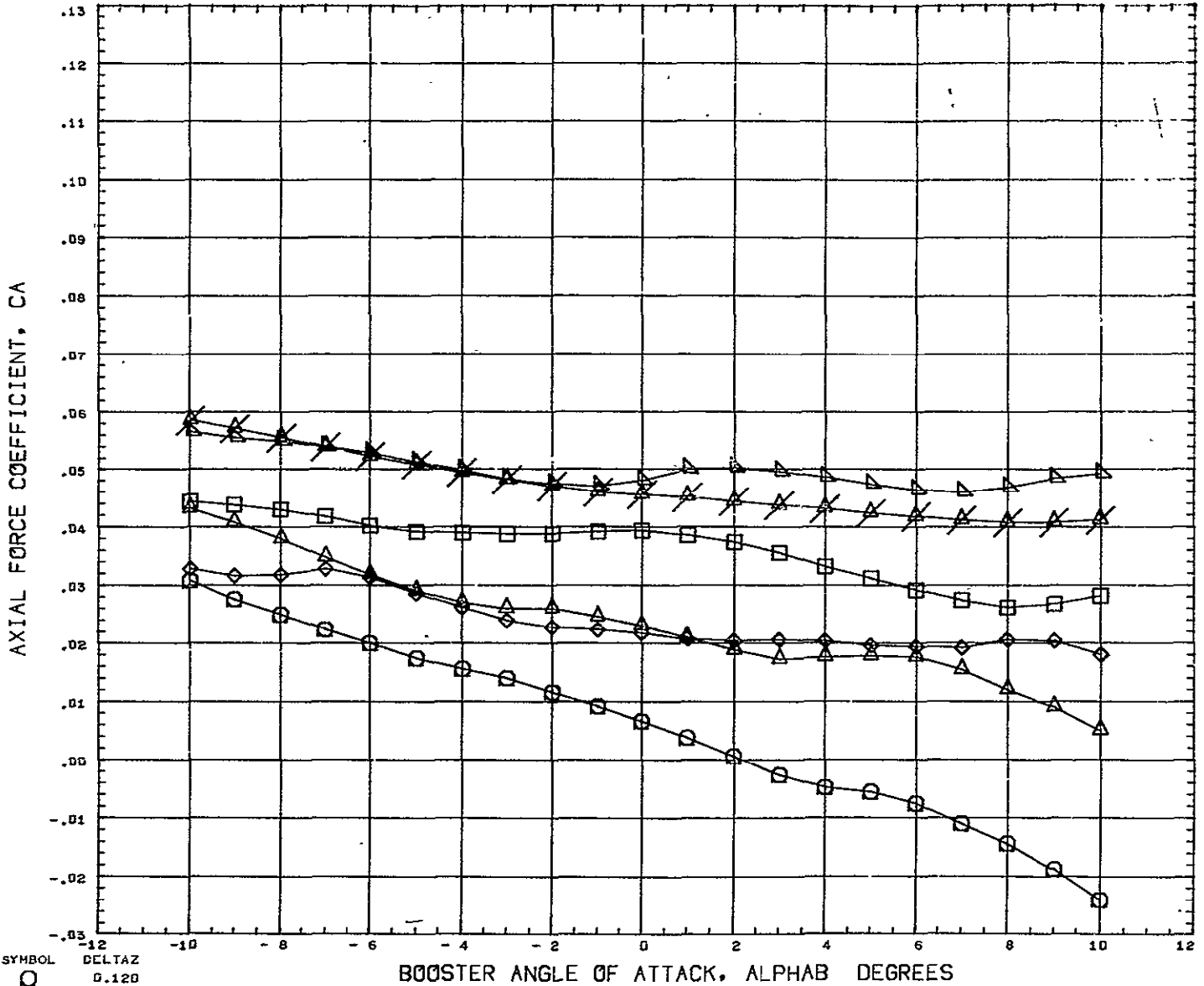

SYMBOL ○ ◇ □ △ ×	DELTAX 0.120 0.151 0.182 0.228 0.352 10.000	PARAMETRIC VALUES BSTFOW 100.000 ORBPOW 100.000 DELTAX - 0.391 ALPHAI 0.000 MACH 5.010 ELVBST 0.000 ELVORB 0.000 BETA 0.000	REFERENCE INFORMATION REFS 23.6890 SQ IN REFL 4.1930 IN REFB 6.5000 IN XMRF 4.9170 IN YMRF 0.0000 IN ZMRF 1.3900 IN SCALE 0.0055
---------------------------------	---	---	---

REFERENCE FILE



AEDC VA 1163 MDAC BOOSTER AND ORBITER TEST DATA AT MACH NUMBER 5

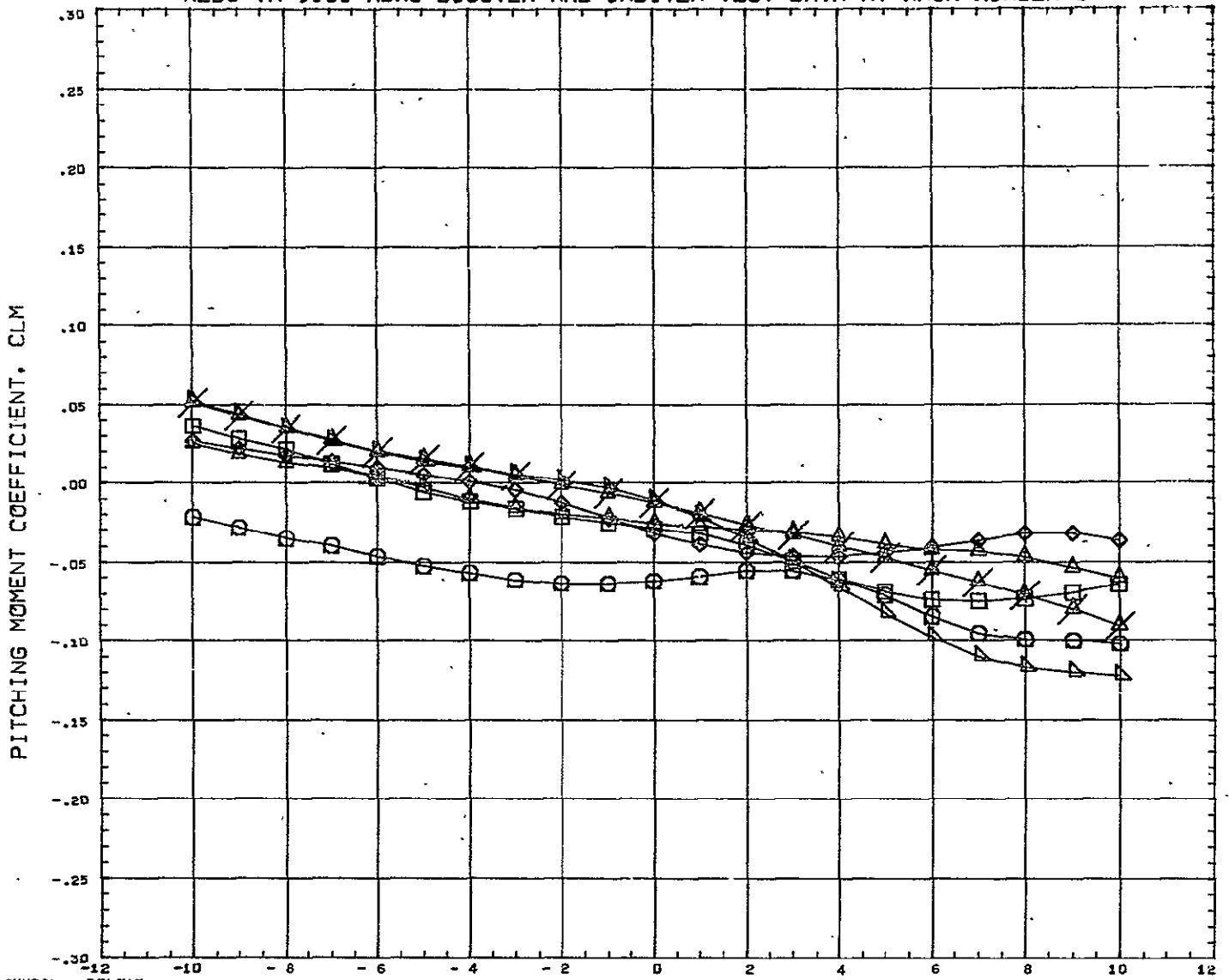

SYMBOL	DELTA Z	PARAMETRIC VALUES				REFERENCE INFORMATION		
○	0.120							
□	0.151							
◇	0.182	BSTPOW	100.000	ORBPOW	100.000	REFS	23.6890	SQ IN
△	0.228	DELTA X	- 0.143	ALPHA I	0.000	REFL	4.1930	IN
×	0.352	MACH	5.010	ELVBST	0.000	REFB	6.5000	IN
	10.000	ELVORB	0.000	BETA	0.000	XMRF	4.9170	IN
						YMRF	0.0000	IN
						ZMRF	1.3900	IN
						SCALE	0.0055	

REFERENCE FILE

# AEDC VA 1163 MDAC BOOSTER AND ORBITER TEST DATA AT MACH NUMBER 5

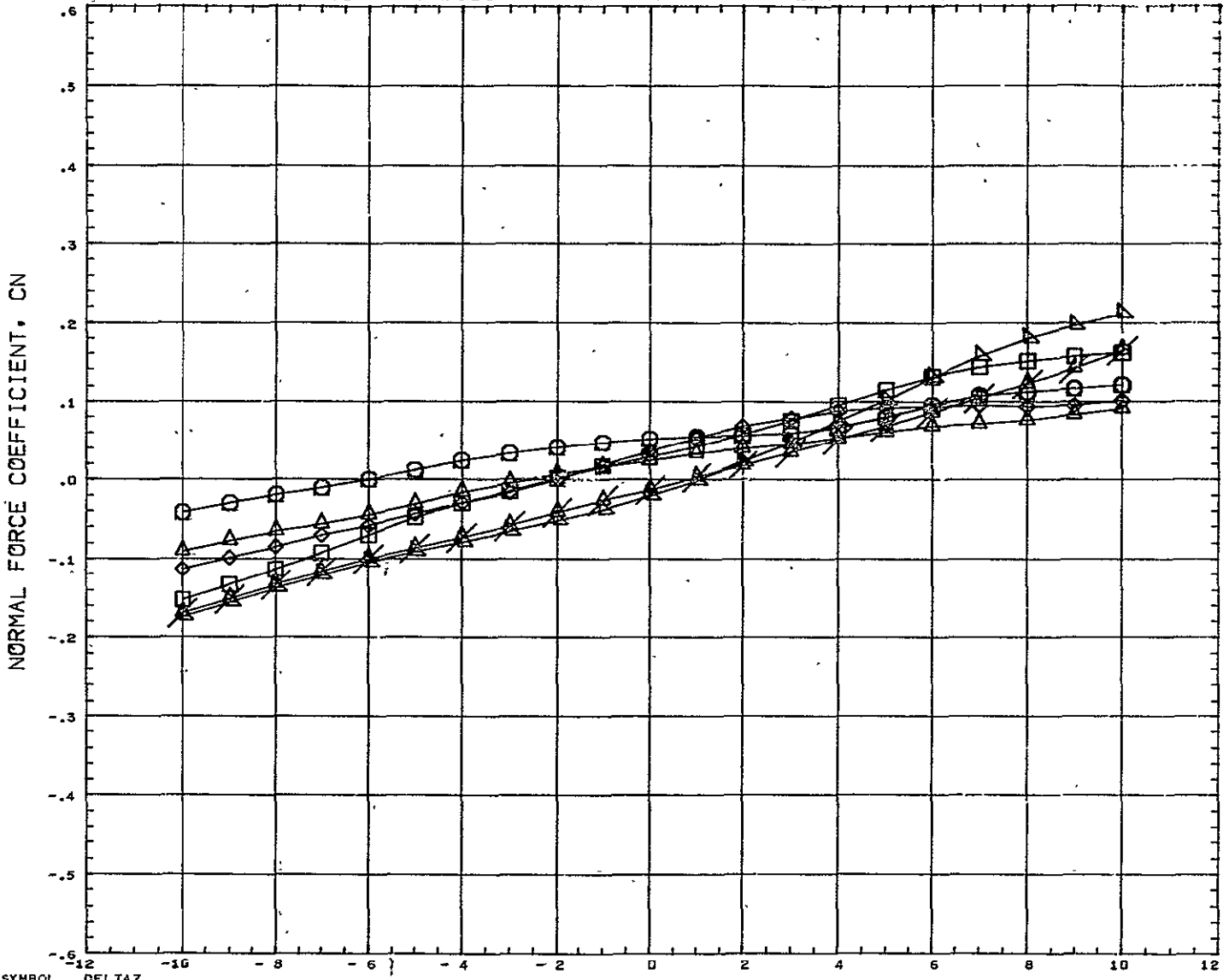

SYMBOL ○ ◇ □ △	DELTAX 0.120 0.151 0.182 0.228 0.352 10.000	PARAMETRIC VALUES BSTPOW 100.000 ORBPOW 100.000 DELTAX - 0.143 ALPHAI 0.000 MACH 5.010 ELVBST 0.000 ELVORB 0.000 BETA 0.000	REFERENCE INFORMATION REFS 23.6890 SQ IN REFL 4.1930 IN REFB 6.5000 IN XMRP 4.9170 IN YMRP 0.0000 IN ZMRP 1.3900 IN SCALE 0.0055
----------------------------	---	---	---

REFERENCE FILE

# AEDC VA 1163 MDAC BOOSTER AND ORBITER TEST DATA AT MACH NUMBER 5

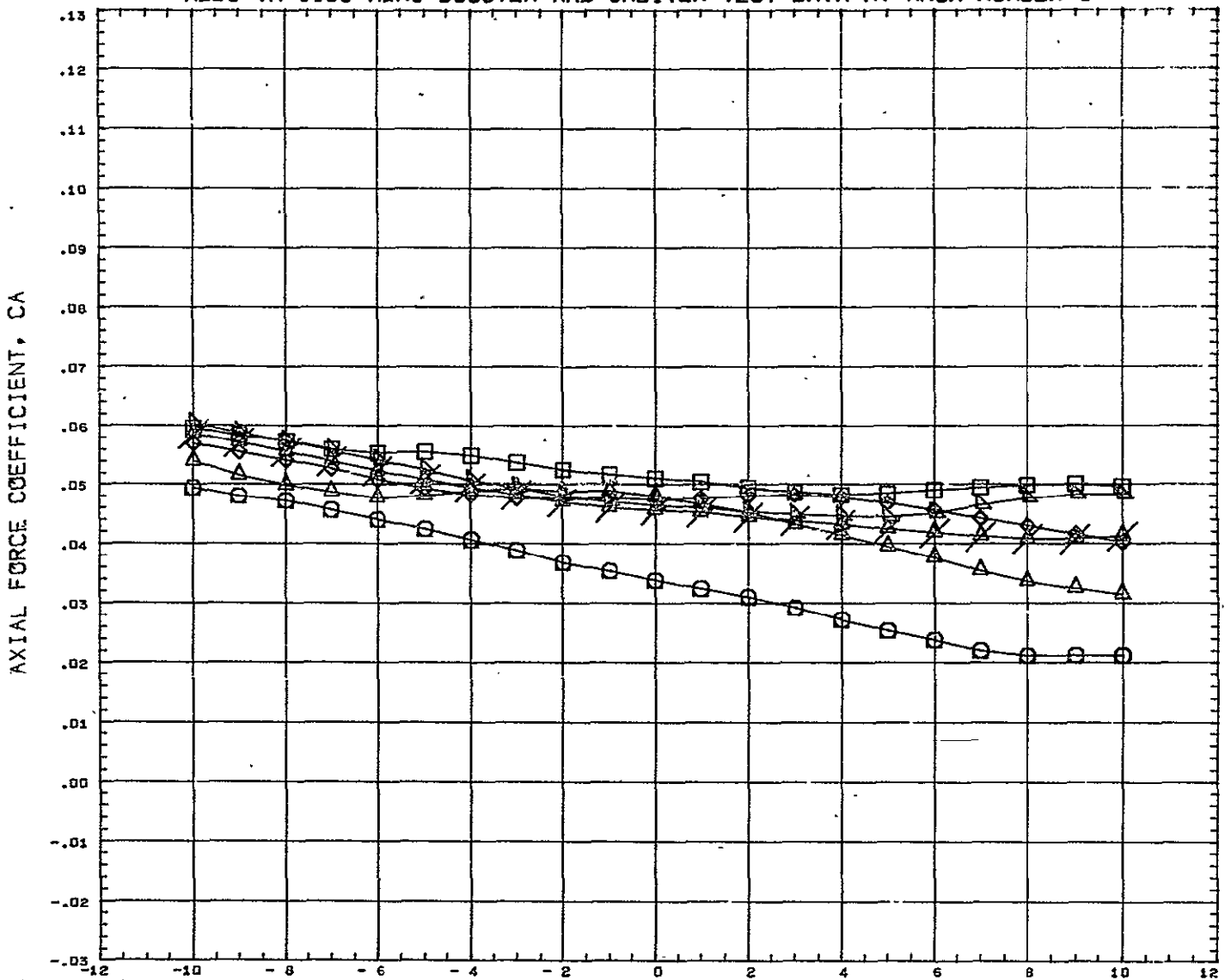

SYMBOL	DELTA Z	PARAMETRIC VALUES				REFERENCE INFORMATION		
○	0.120							
◇	0.151							
□	0.182	BSTPOW	100.000	ORBPOW	100.000	REFS	23.6890	SQ IN
△	0.228	DELTA X	- 0.143	ALPHA I	0.000	REFL	4.1930	IN
×	0.352	MACH	5.010	ELVOST	0.000	REFB	6.5000	IN
○	10.000	ELVORB	0.000	BETA	0.000	XMRP	4.9170	IN
						YMRP	0.0000	IN
						ZMRP	1.3900	IN
						SCALE	0.0055	

REFERENCE FILE

# AEDC VA 1163 MDAC BOOSTER AND ORBITER TEST DATA AT MACH NUMBER 5

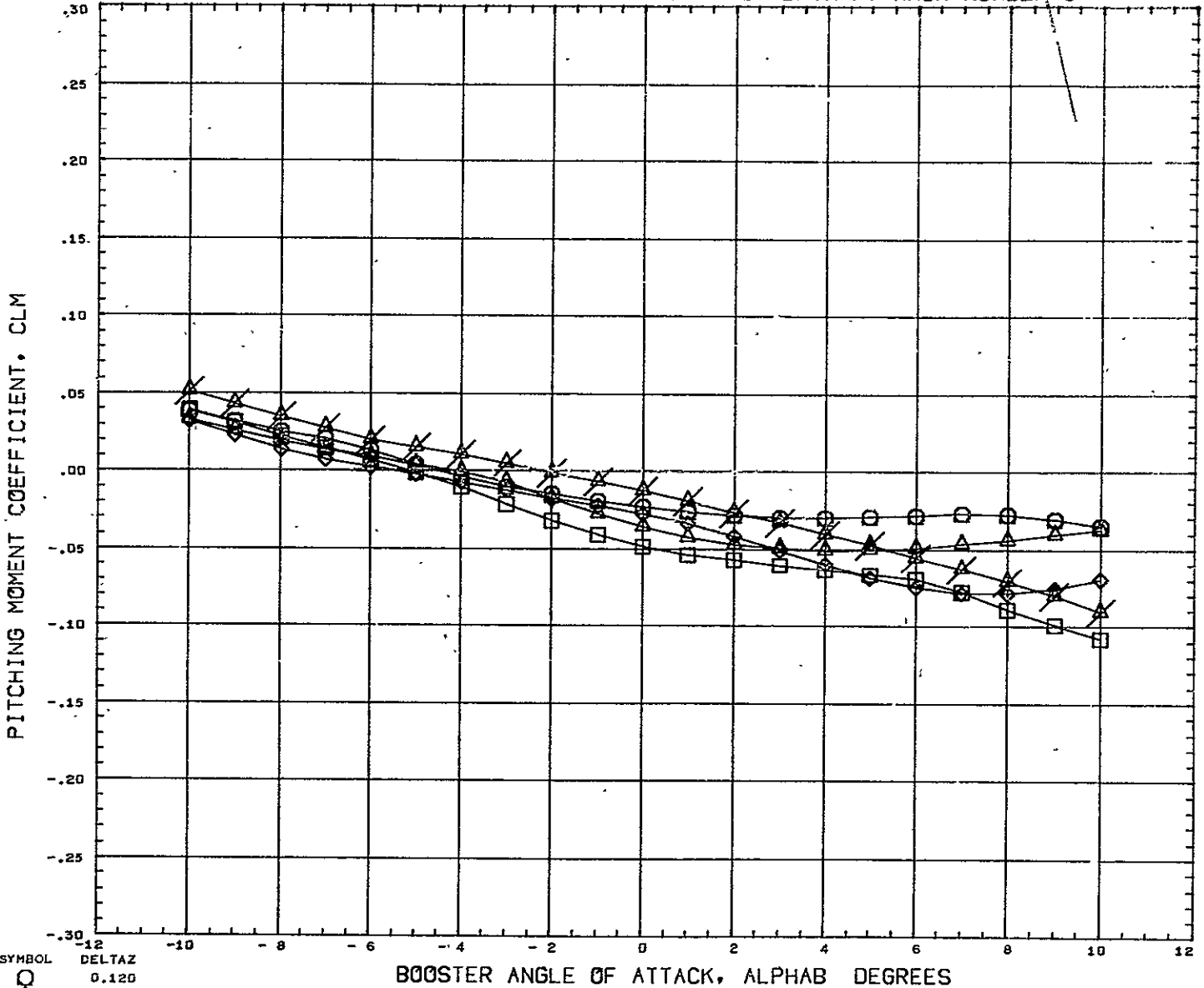

SYMBOL	DELTAZ	PARAMETRIC VALUES			
○	0.120				
◇	0.151	BSTPOW	100.000	ORBPOW	100.000
□	0.182	DELTAZ	- 0.019	ALPHA1	0.000
△	0.220	MACH	5.010	ELVBST	0.000
○	10.000	ELVORB	0.000	BETA	0.000

REFERENCE INFORMATION		
REFS	23.6890	SG IN
REFL	4.1930	IN
REFB	6.5000	IN
XMRP	4.9170	IN
YMRP	0.0000	IN
ZMRP	1.3900	IN
SCALE	0.0055	

REFERENCE FILE

# AEDC VA 1163 MDAC BOOSTER AND ORBITER TEST DATA AT MACH NUMBER 5

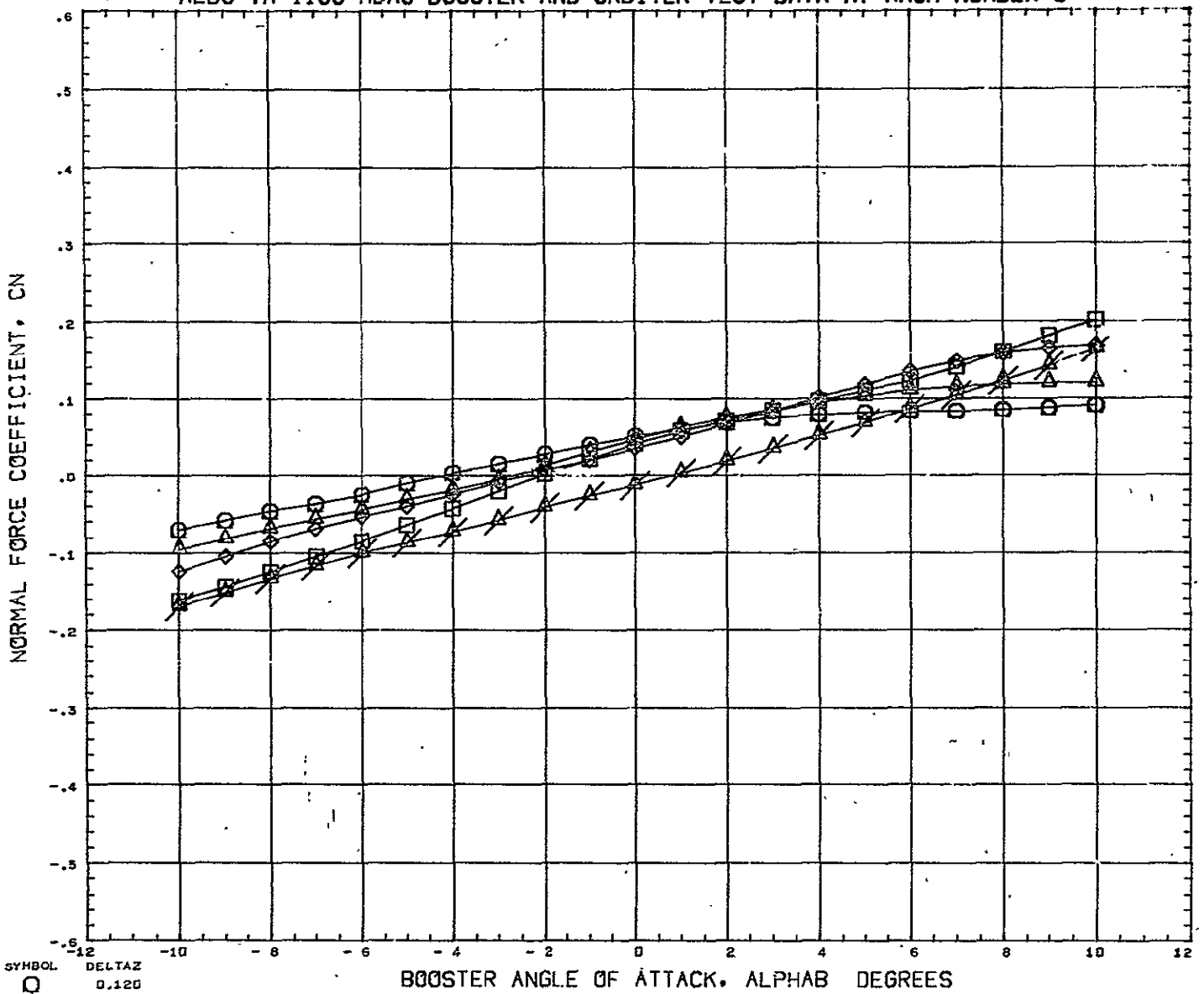

SYMBOL ○ △ ◇ □ ×	DELTAZ 0.120 0.151 0.182 0.229 10.000	PARAMETRIC VALUES BSTPOW 100.000 ORBPOW 100.000 DELTAX: - 0.019 ALPHAI 0.000 MACH 5.010 ELVBST 0.000 ELVORB 0.000 BETA 0.000	REFERENCE INFORMATION REFS 23.6890 SQ IN REFL 4.1930 IN REFB 6.5000 IN XMRP 4.9170 IN YMRP 0.0000 IN ZMRP 1.3900 IN SCALE 0.0055
---------------------------------	--	--	---

REFERENCE FILE

# AEDC VA 1163 MDAC BOOSTER AND ORBITER TEST DATA AT MACH NUMBER 5

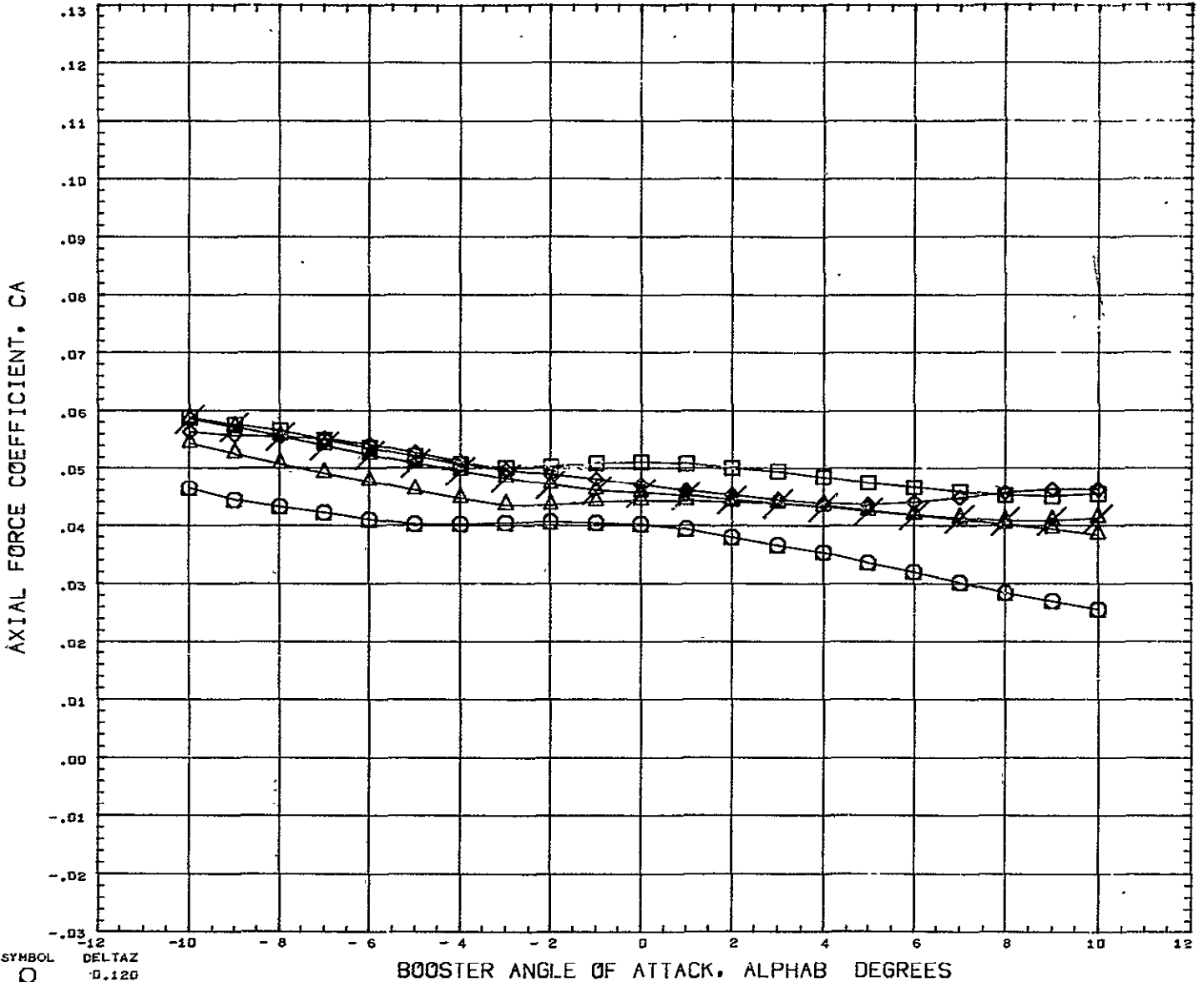

SYMBOL ○ ◇ □ △ ×	DELTAZ 0.120 0.151 0.182 0.228 10.000	<b>PARAMETRIC VALUES</b> BSTPOW 100.000 ORBPOW 100.000 DELTAX - 0.019 ALPHA1 0.000 MACH 5.010 ELVBST 0.000 ELVORB 0.000 BETA 0.000	<b>REFERENCE INFORMATION</b> REFS 23.6890 SQ IN REFL 4.1930 IN REFB 6.5000 IN XMRP 4.9170 IN YMRP 0.0000 IN ZMRP 1.3900 IN SCALE 0.0055
REFERENCE FILE			

# AEDC VA 1163 MDAC BOOSTER AND ORBITER TEST DATA AT MACH NUMBER 5

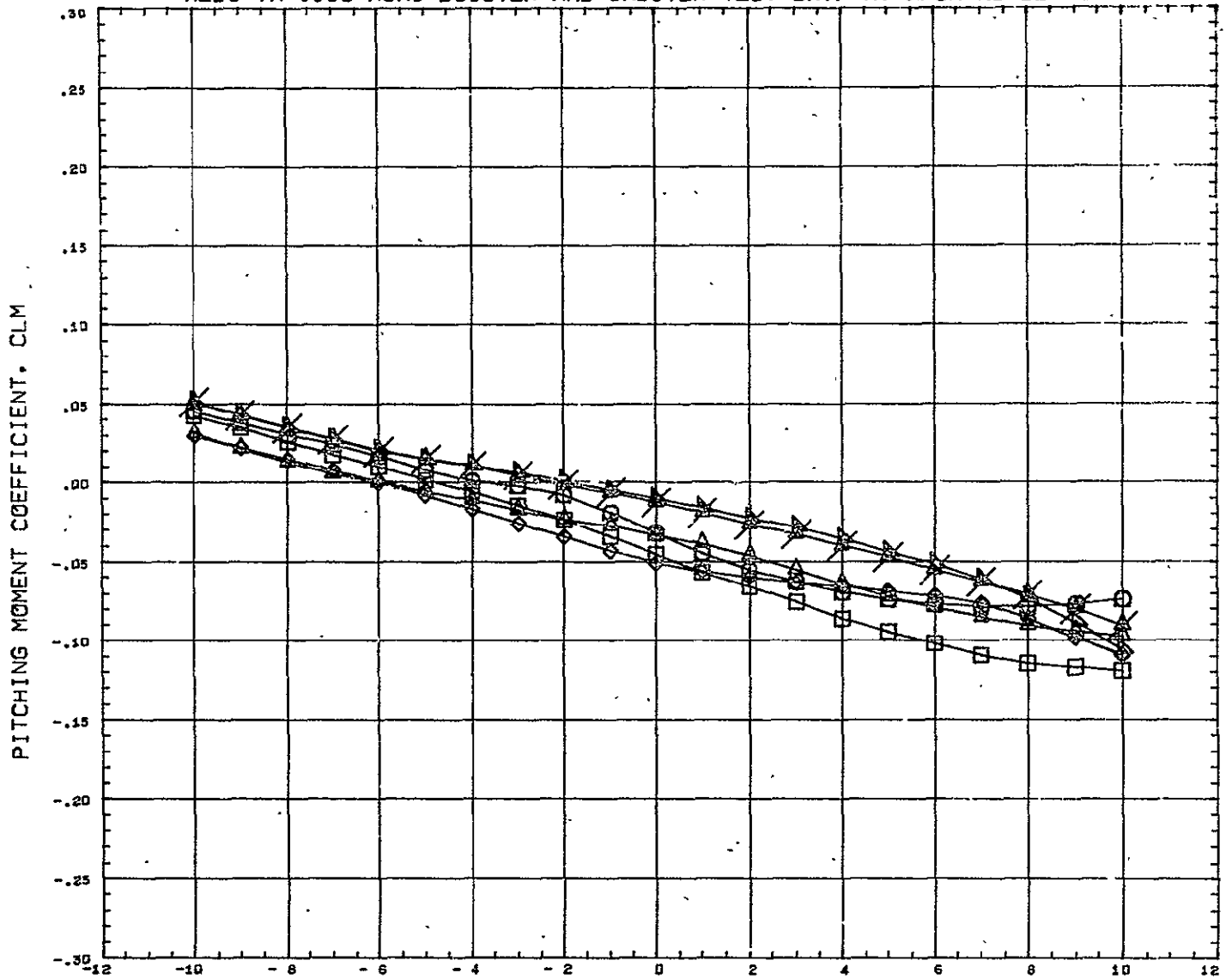

SYMBOL	DELTA Z	PARAMETRIC VALUES				REFERENCE INFORMATION		
○	0.120							
◇	0.151							
□	0.182	BSTPOW	100.000	ORBPOW	100.000	REFS	23.6890	SQ IN
△	0.228	DELTA X	0.104	ALPHA I	0.000	REFL	4.1930	IN
×	0.352	MACH	5.010	ELVST	0.000	REFB	6.5000	IN
	10.000	ELVORB	0.000	BETA	0.000	XMRP	4.9170	IN
						YMRP	0.0600	IN
						ZMRP	1.3900	IN
						SCALE	0.0055	

REFERENCE FILE

# AEDC VA 1163 MDAC BOOSTER AND ORBITER TEST DATA AT MACH NUMBER 5

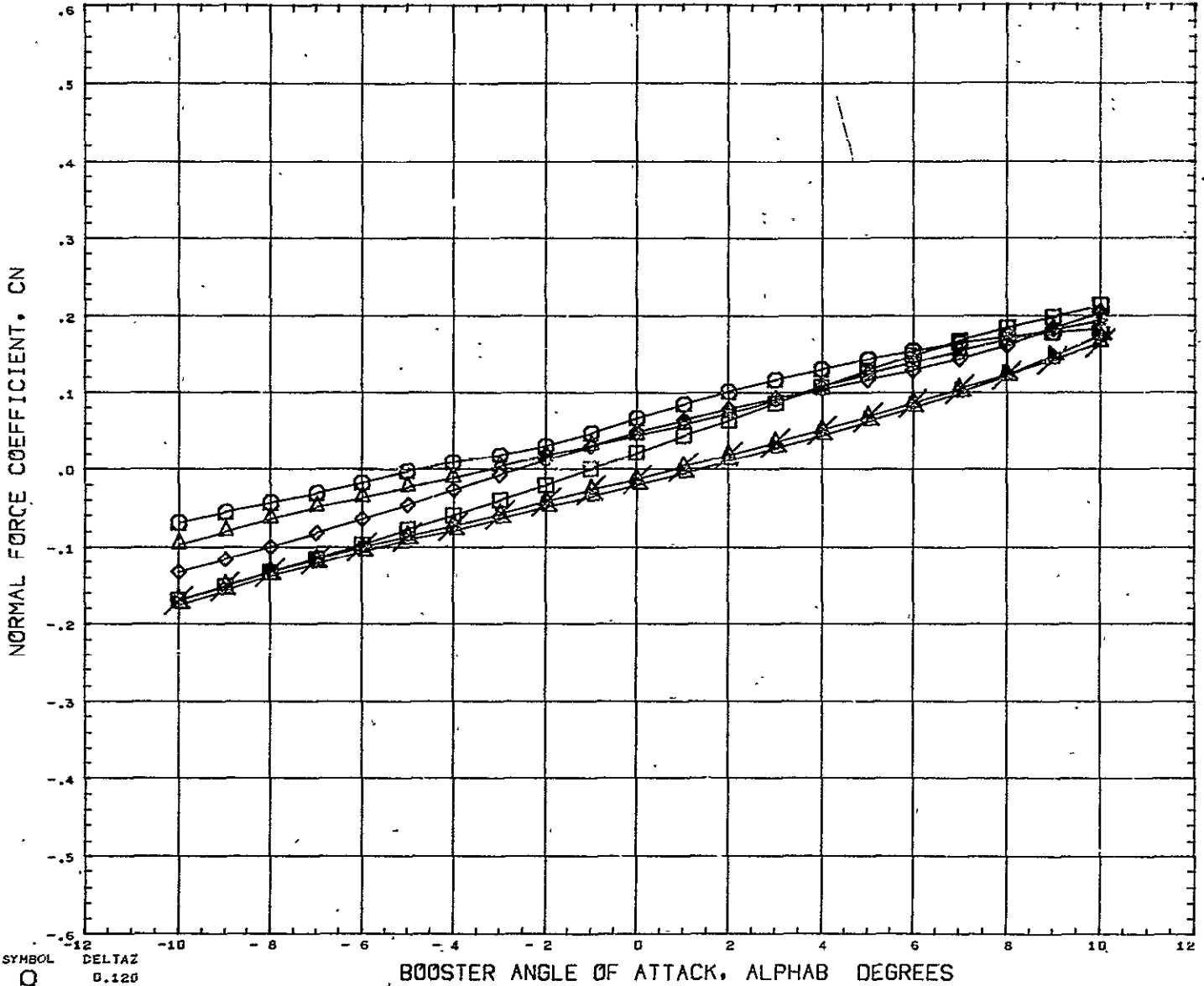

SYMBOL ○ □ △ ◇ ▲	DELTA Z 0.120 0.151 0.182 0.226 0.352 10.000	PARAMETRIC VALUES BSTPOW 100.000 ORBPOW 190.000 DELTAX 0.104 ALPHAI 0.000 MACH 5.010 ELVBST 0.000 ELVORB 0.000 BETA 0.000	REFERENCE INFORMATION REFS 23.6890 SQ IN REFL 4.1930 IN REFB 6.5000 IN XMRP 4.9170 IN YMRP 0.0000 IN ZMRP 1.3900 IN SCALE 0.0055
---------------------------------	--	---	---

REFERENCE FILE



# AEDC VA 1163 MDAC BOOSTER AND ORBITER TEST DATA AT MACH NUMBER 5

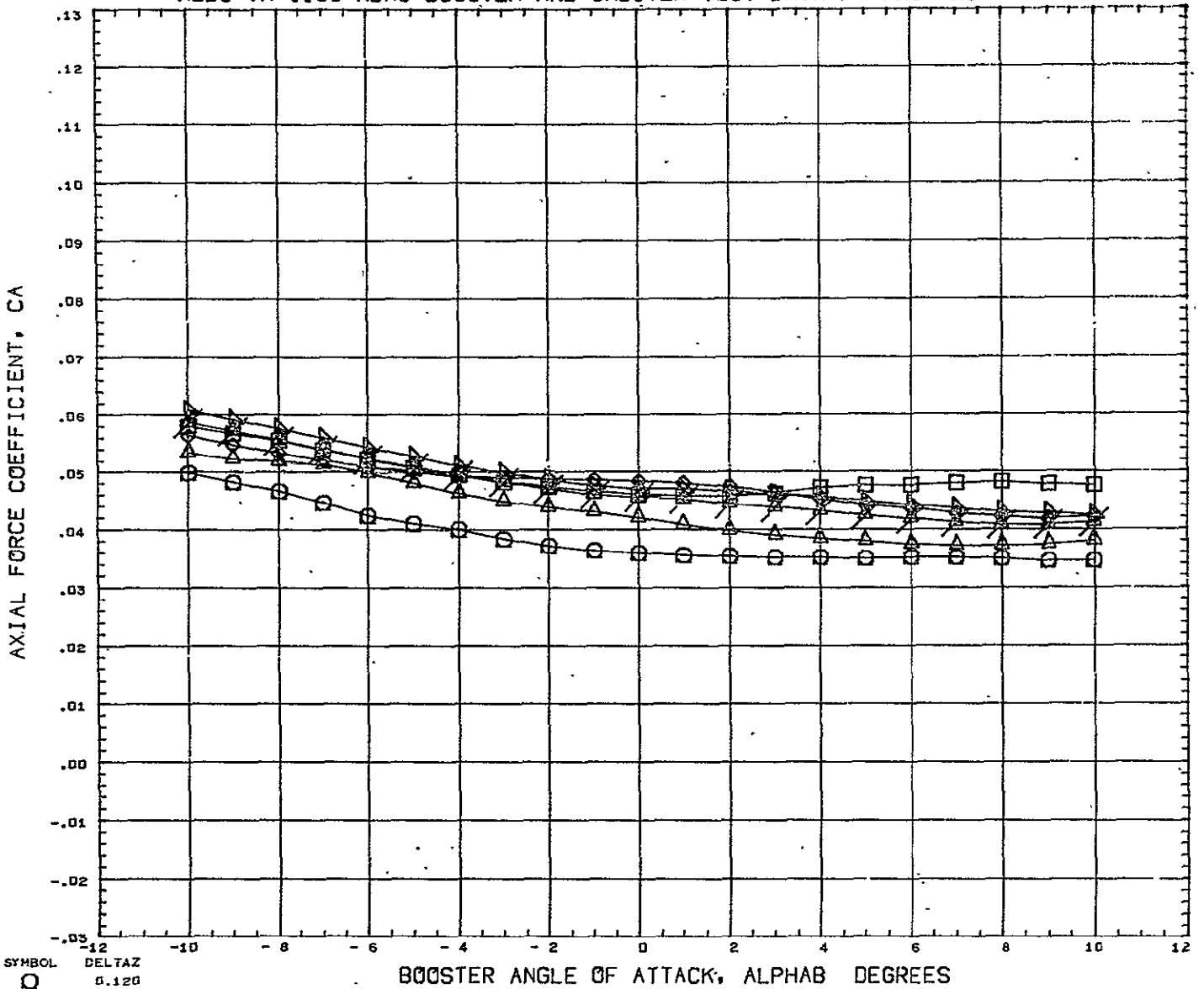

SYMBOL	DELTAZ	PARAMETRIC VALUES				REFERENCE INFORMATION		
○	0.120							
○	0.151							
○	0.182	BSTPOW	100.000	ORBPOW	100.000	REFS	23.6890	SQ IN
○	0.220	DELTAZ	0.104	ALPHA1	0.000	REFL	4.1930	IN
○	0.352	MACH	5.010	ELVBST	0.000	REFB	6.5000	IN
○	10.000	ELVORB	0.000	BETA	0.000	XMRP	4.9170	IN
						YMRP	0.0000	IN
						ZMRP	1.3900	IN
						SCALE	0.0055	

REFERENCE FILE

# AEDC VA 1163 MDAC BOOSTER AND ORBITER TEST DATA AT MACH NUMBER 5

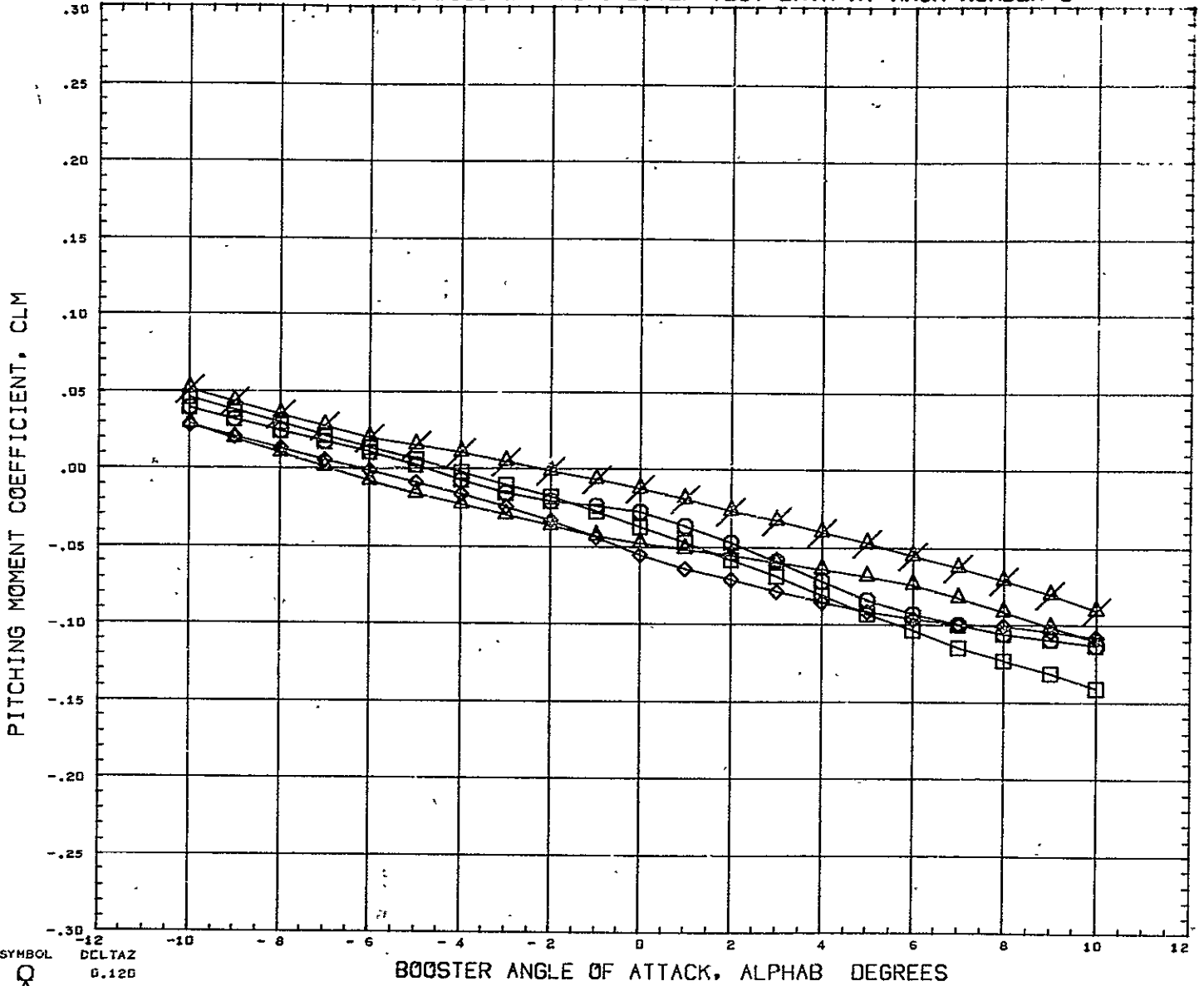

SYMBOL	DELTAZ
○	0.126
◇	0.151
◇	0.182
□	0.228
×	10.000

PARAMETRIC VALUES			
BSTPOW	100.000	ORBPOW	100.000
DELTAZ	0.166	ALPHA1	0.000
MACH	5.010	ELVBST	0.000
ELVORB	0.000	BETA	0.009

REFERENCE INFORMATION		
REFS	23.6890	SQ IN
REFL	4.1930	IN
REFB	6.5000	IN
XMRP	4.9170	IN
YMRP	0.0000	IN
ZMRP	1.3800	IN
SCALE	0.0055	

REFERENCE FILE

# AEDC VA 1163 MDAC BOOSTER AND ORBITER TEST DATA AT MACH NUMBER 5

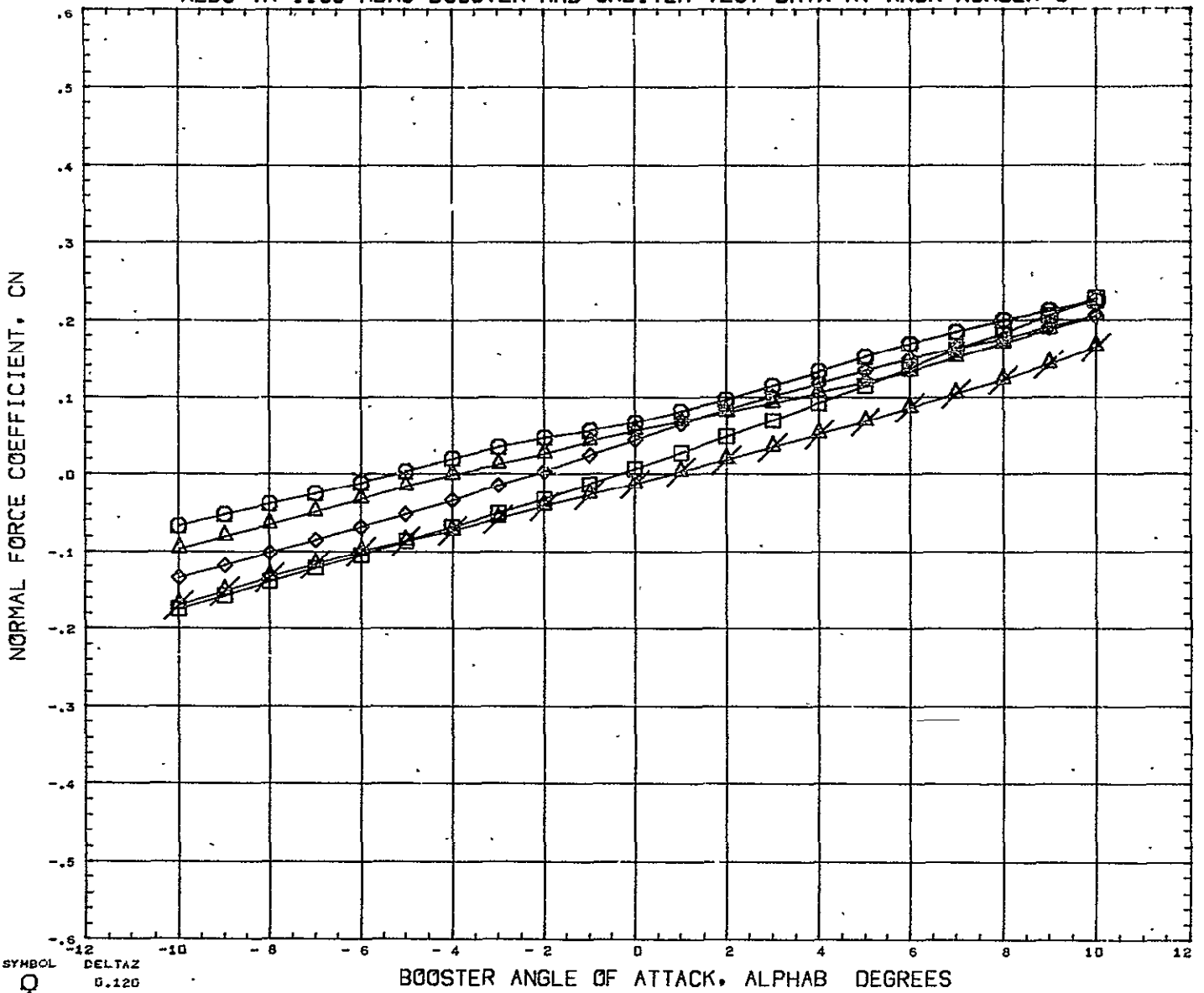

SYMBOL ○ △ ◇ □ ×	DELTA Z 0.120 0.151 0.182 0.228 10.000	PARAMETRIC VALUES BSTPOW 100.000 ORBPOW 100.000 DELTAX 0.166 ALPHA1 0.000 MACH 5.010 ELVBST 0.000 ELVORB 0.000 BETA 0.000	REFERENCE INFORMATION REFS 23.6890 SQ IN REFL 4.1930 IN REFB 6.5000 IN XMRP 4.9176 IN YMRP 0.0000 IN ZMRP 1.3960 IN SCALE 0.0055
REFERENCE FILE			

# AEDC VA 1163 MDAC BOOSTER AND ORBITER TEST DATA AT MACH NUMBER 5

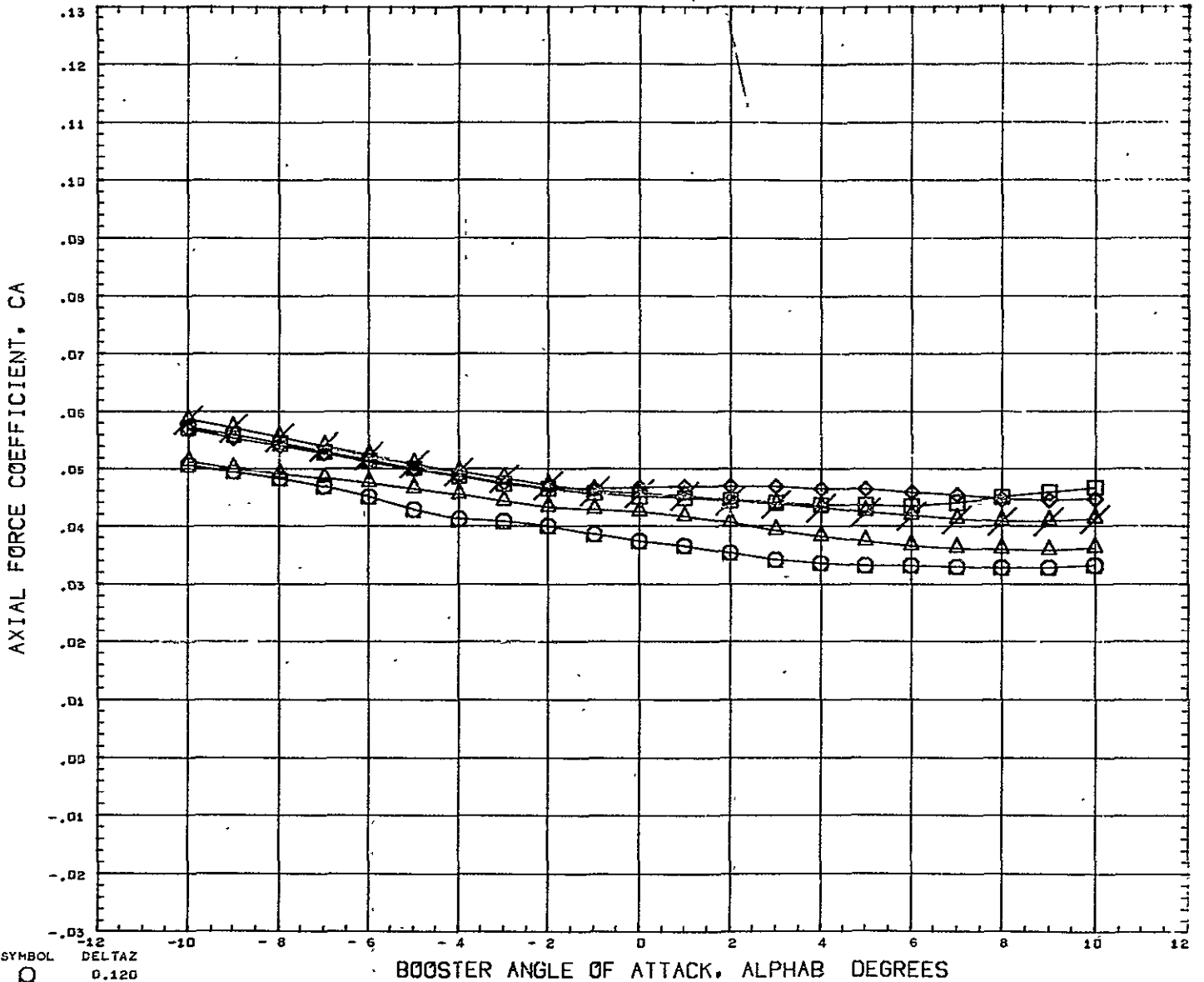

SYMBOL ○ △ □ ◇ ×	DELTAZ 0.120 0.151 0.182 0.228 10.000	<table border="0" style="width: 100%;"> <tr> <th colspan="4" style="text-align: center;">PARAMETRIC VALUES</th> </tr> <tr> <td>BSTPOW</td> <td>100.000</td> <td>ORBPOW</td> <td>100.000</td> </tr> <tr> <td>DELTAZ</td> <td>0.166</td> <td>ALPHA1</td> <td>0.000</td> </tr> <tr> <td>MACH</td> <td>5.010</td> <td>ELVBST</td> <td>0.000</td> </tr> <tr> <td>ELVORB</td> <td>0.000</td> <td>BETA</td> <td>0.000</td> </tr> </table>	PARAMETRIC VALUES				BSTPOW	100.000	ORBPOW	100.000	DELTAZ	0.166	ALPHA1	0.000	MACH	5.010	ELVBST	0.000	ELVORB	0.000	BETA	0.000	<table border="0" style="width: 100%;"> <tr> <th colspan="3" style="text-align: center;">REFERENCE INFORMATION</th> </tr> <tr> <td>REFS</td> <td>23.6890</td> <td>99 IN</td> </tr> <tr> <td>REFL</td> <td>4.1930</td> <td>IN</td> </tr> <tr> <td>REFB</td> <td>6.5000</td> <td>IN</td> </tr> <tr> <td>XMRP</td> <td>4.9170</td> <td>IN</td> </tr> <tr> <td>YMRP</td> <td>0.0000</td> <td>IN</td> </tr> <tr> <td>ZMRP</td> <td>1.3900</td> <td>IN</td> </tr> <tr> <td>SCALE</td> <td>0.0055</td> <td></td> </tr> </table>	REFERENCE INFORMATION			REFS	23.6890	99 IN	REFL	4.1930	IN	REFB	6.5000	IN	XMRP	4.9170	IN	YMRP	0.0000	IN	ZMRP	1.3900	IN	SCALE	0.0055	
PARAMETRIC VALUES																																															
BSTPOW	100.000	ORBPOW	100.000																																												
DELTAZ	0.166	ALPHA1	0.000																																												
MACH	5.010	ELVBST	0.000																																												
ELVORB	0.000	BETA	0.000																																												
REFERENCE INFORMATION																																															
REFS	23.6890	99 IN																																													
REFL	4.1930	IN																																													
REFB	6.5000	IN																																													
XMRP	4.9170	IN																																													
YMRP	0.0000	IN																																													
ZMRP	1.3900	IN																																													
SCALE	0.0055																																														

REFERENCE FILE

# AEDC VA 1163 MDAC BOOSTER AND ORBITER TEST DATA AT MACH NUMBER 5

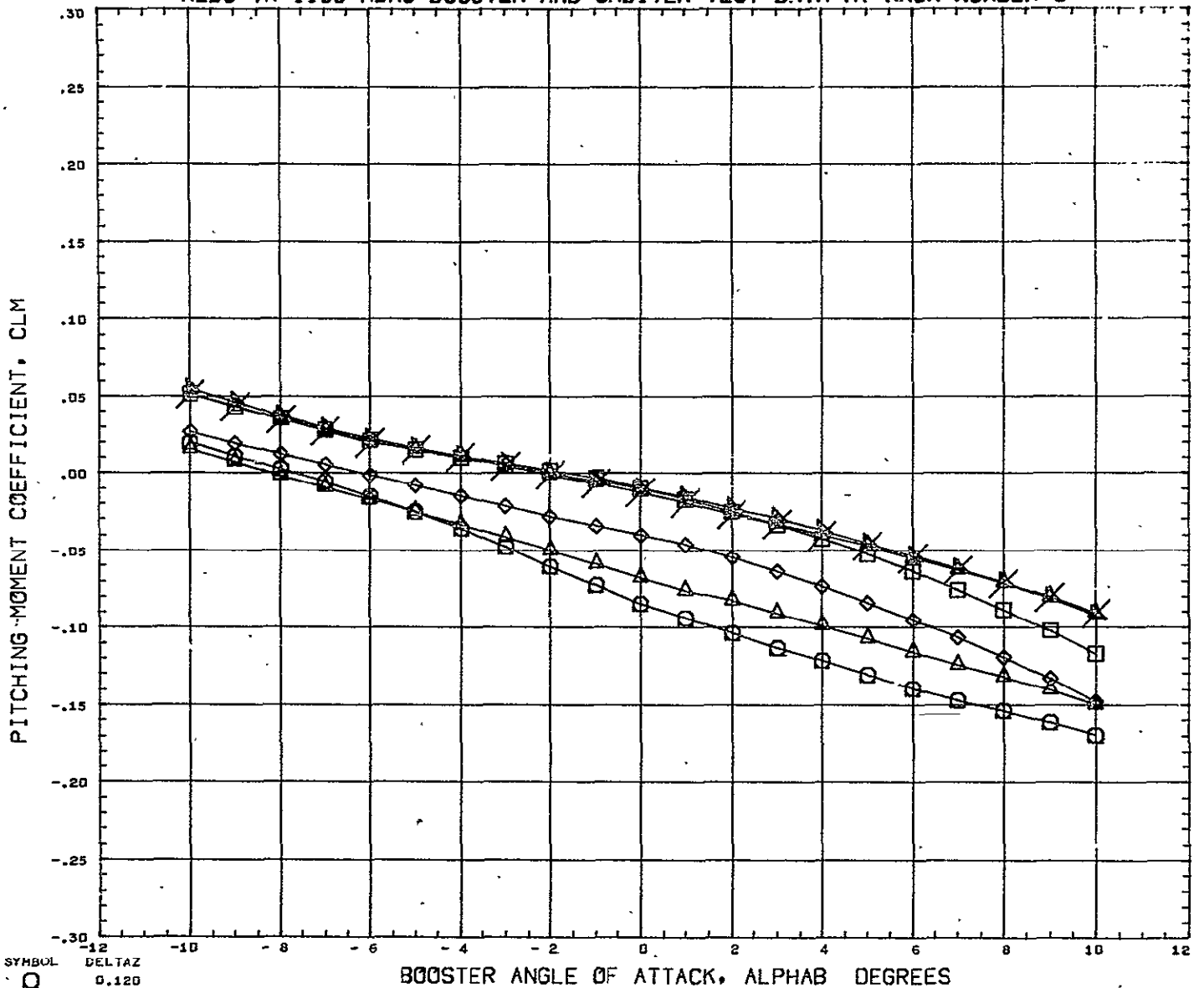

SYMBOL ○ ◇ □ △ ×	DELTAZ 0.120 0.151 0.162 0.228 0.352 10.000	PARAMETRIC VALUES 3STPOW 100.000 ORBPOW 100.000 DELTAX 0.351 ALPHAI 0.000 MACH 5.010 ELVBST 0.000 ELVORB 0.000 BETA 0.000	REFERENCE INFORMATION REFS 23.6890 SQ IN REFL 4.1930 IN REFB 6.5000 IN XMRP 4.9170 IN YMRP 0.0000 IN ZMRP 1.3900 IN SCALE 0.0055
REFERENCE FILE			

# AEDC VA 1163 MDAC BOOSTER AND ORBITER TEST DATA AT MACH NUMBER 5

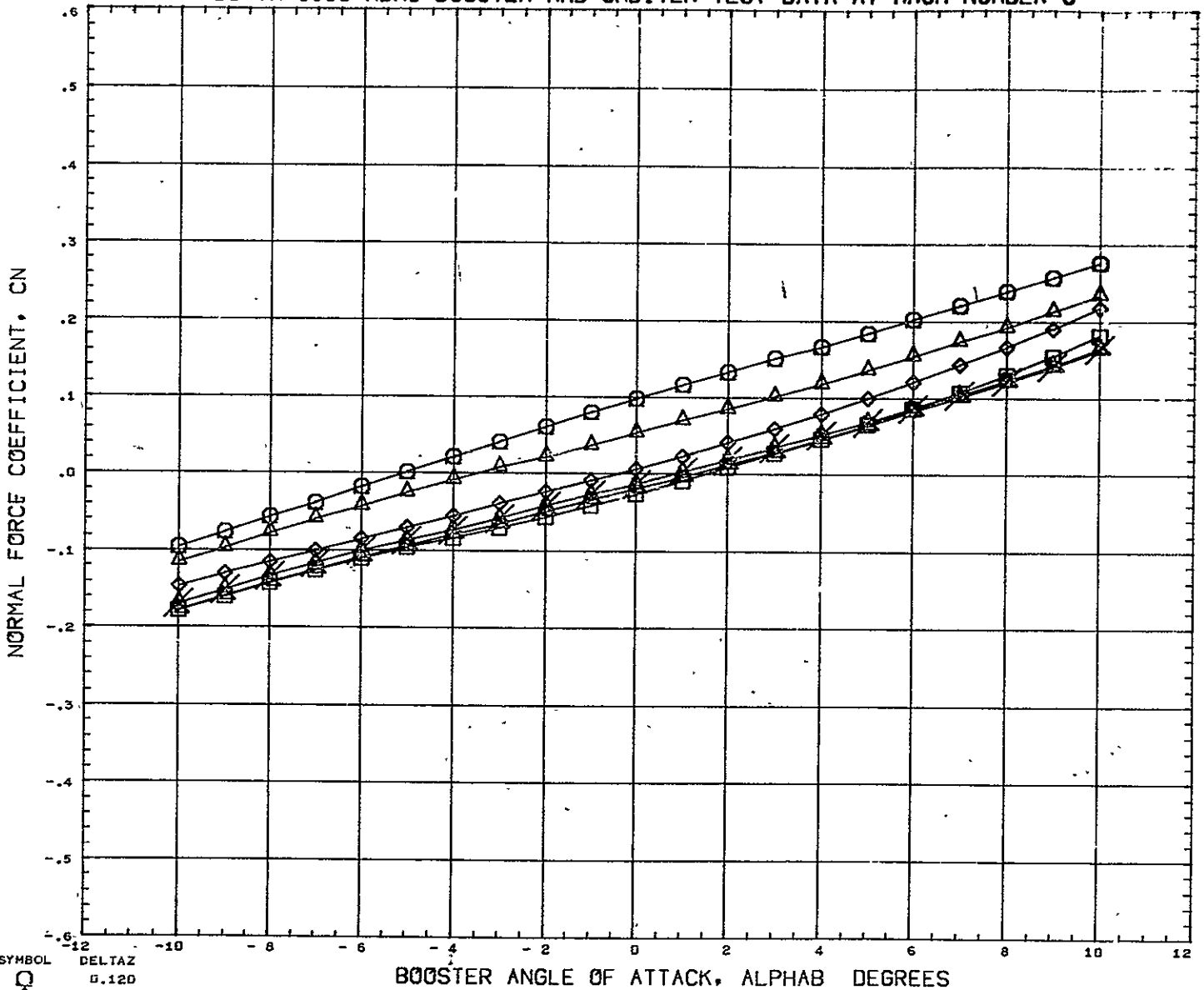

SYMBOL ○ △ ◇ □ ☆	DELTAZ 0.120 0.151 0.182 0.228 0.352 10.000	<table border="0" style="width: 100%;"> <tr> <th colspan="4" style="text-align: left;">PARAMETRIC VALUES</th> </tr> <tr> <td>BSTPOW</td> <td>100.000</td> <td>ORBPOW</td> <td>100.000</td> </tr> <tr> <td>DELTAZ</td> <td>0.351</td> <td>ALPHA1</td> <td>0.000</td> </tr> <tr> <td>MACH</td> <td>5.010</td> <td>ELVBST</td> <td>0.000</td> </tr> <tr> <td>ELVORB</td> <td>0.000</td> <td>BETA</td> <td>0.000</td> </tr> </table>	PARAMETRIC VALUES				BSTPOW	100.000	ORBPOW	100.000	DELTAZ	0.351	ALPHA1	0.000	MACH	5.010	ELVBST	0.000	ELVORB	0.000	BETA	0.000	<table border="0" style="width: 100%;"> <tr> <th colspan="3" style="text-align: left;">REFERENCE INFORMATION</th> </tr> <tr> <td>REFS</td> <td>23.6890</td> <td>SQ IN</td> </tr> <tr> <td>REFL</td> <td>4.1930</td> <td>IN</td> </tr> <tr> <td>REFB</td> <td>6.5000</td> <td>IN</td> </tr> <tr> <td>XMRP</td> <td>4.9170</td> <td>IN</td> </tr> <tr> <td>YMRP</td> <td>0.0000</td> <td>IN</td> </tr> <tr> <td>ZMRP</td> <td>1.3900</td> <td>IN</td> </tr> <tr> <td>SCALE</td> <td>0.0055</td> <td></td> </tr> </table>	REFERENCE INFORMATION			REFS	23.6890	SQ IN	REFL	4.1930	IN	REFB	6.5000	IN	XMRP	4.9170	IN	YMRP	0.0000	IN	ZMRP	1.3900	IN	SCALE	0.0055	
PARAMETRIC VALUES																																															
BSTPOW	100.000	ORBPOW	100.000																																												
DELTAZ	0.351	ALPHA1	0.000																																												
MACH	5.010	ELVBST	0.000																																												
ELVORB	0.000	BETA	0.000																																												
REFERENCE INFORMATION																																															
REFS	23.6890	SQ IN																																													
REFL	4.1930	IN																																													
REFB	6.5000	IN																																													
XMRP	4.9170	IN																																													
YMRP	0.0000	IN																																													
ZMRP	1.3900	IN																																													
SCALE	0.0055																																														

# AEDC VA 1163 MDAC BOOSTER AND ORBITER TEST DATA AT MACH NUMBER 5

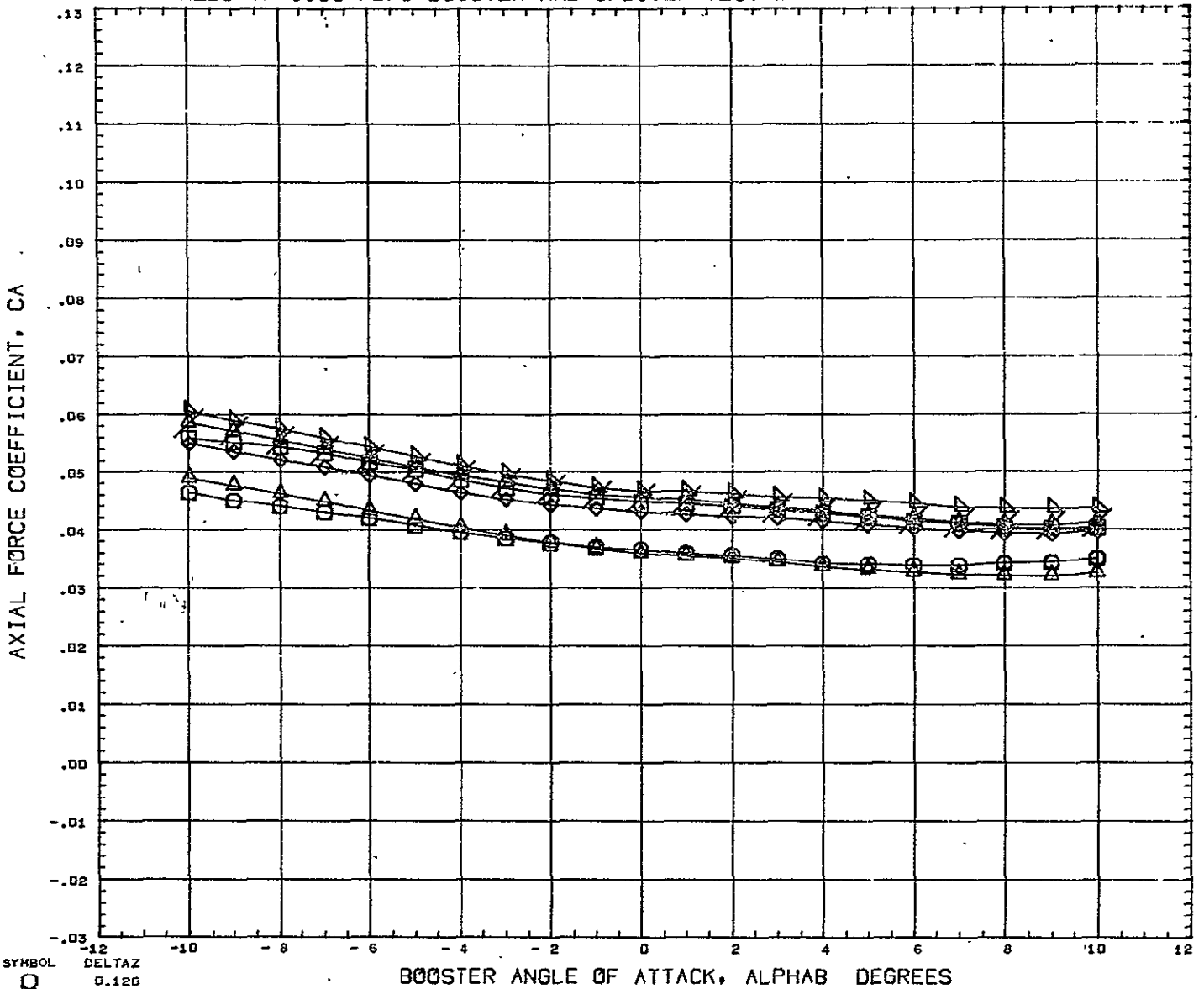

SYMBOL ○ ◇ □ △ ▽	DELTAZ 0.120 0.151 0.182 0.228 0.352 10.000	PARAMETRIC VALUES BSTPOW 100.000 ORBPOW 100.000 DELTAX 0.351 ALPHA1 0.000 MACH 5.010 ELVBS1 0.000 ELVORB 0.000 BETA 0.000	REFERENCE INFORMATION REFS 23.6890 SQ IN REFL 4.1930 IN REFB 6.5000 IN XNRF 4.9170 IN YHRF 0.0000 IN ZHRF 1.3900 IN SCALE 0.0055
---------------------------------	---	---	---

REFERENCE FILE

# AEDC VA 1163 MDAC BOOSTER AND ORBITER TEST DATA AT MACH NUMBER 5

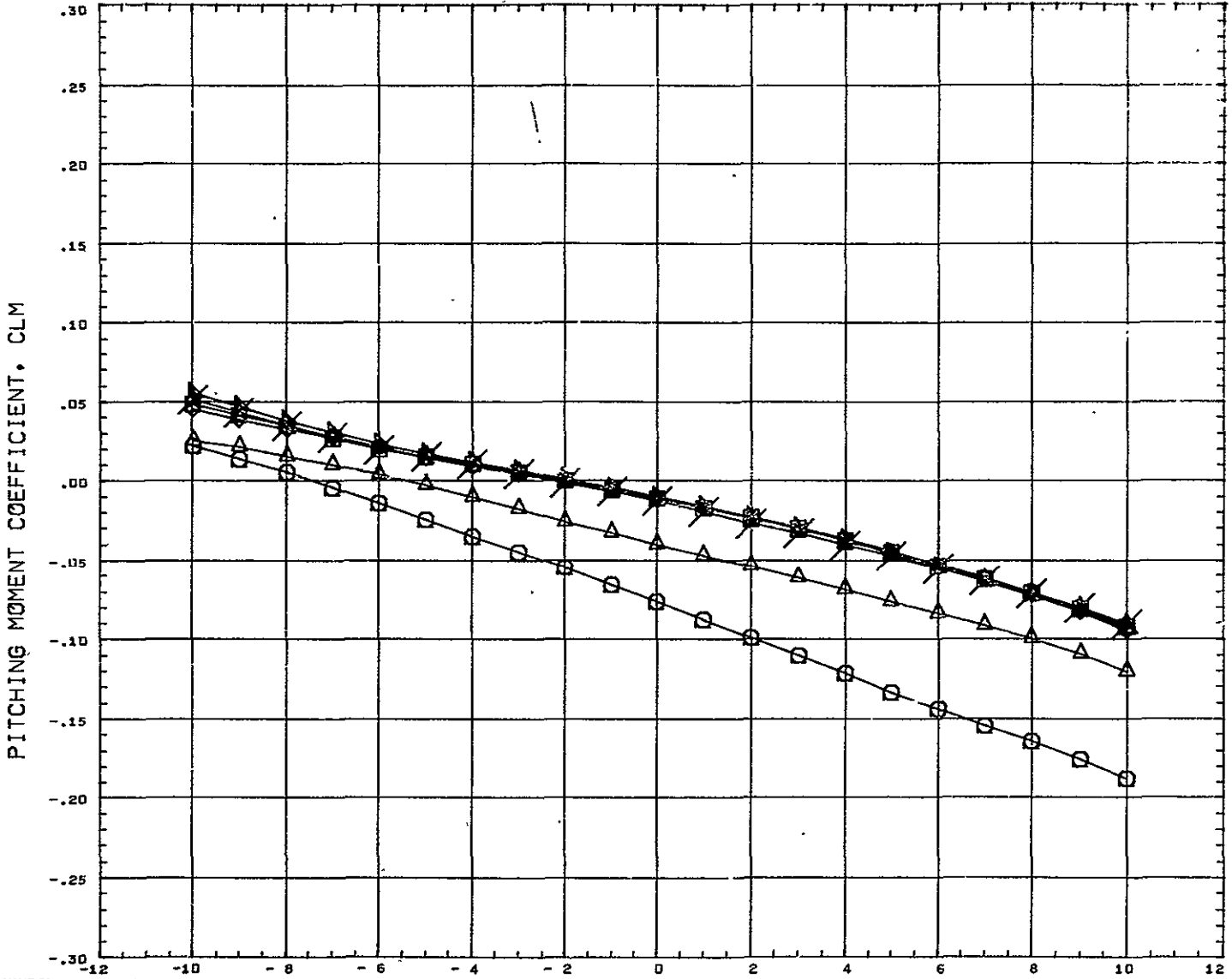

BOOSTER ANGLE OF ATTACK, ALPHA DEGREES

SYMBOL ○ ◇ □ Δ *	DELTAX 0.120 0.151 0.182 0.228 0.352 10.000	PARAMETRIC VALUES BSTPOW 100.000 ORBPOW 100.000 DELTAX 0.522 ALPHAI 0.000 MACH 5.010 ELVBST 0.000 ELVORB 0.000 BETA 0.000	REFERENCE INFORMATION REFS 23.6890 SQ IN REFL 4.1930 IN REFB 6.5000 IN XMRP 4.8170 IN YMRP 0.0000 IN ZMRP 1.3900 IN SCALE 0.0055
---------------------------------	---	---	---

REFERENCE FILE



# AEDC VA 1163 MDAC BOOSTER AND ORBITER TEST DATA AT MACH NUMBER 5

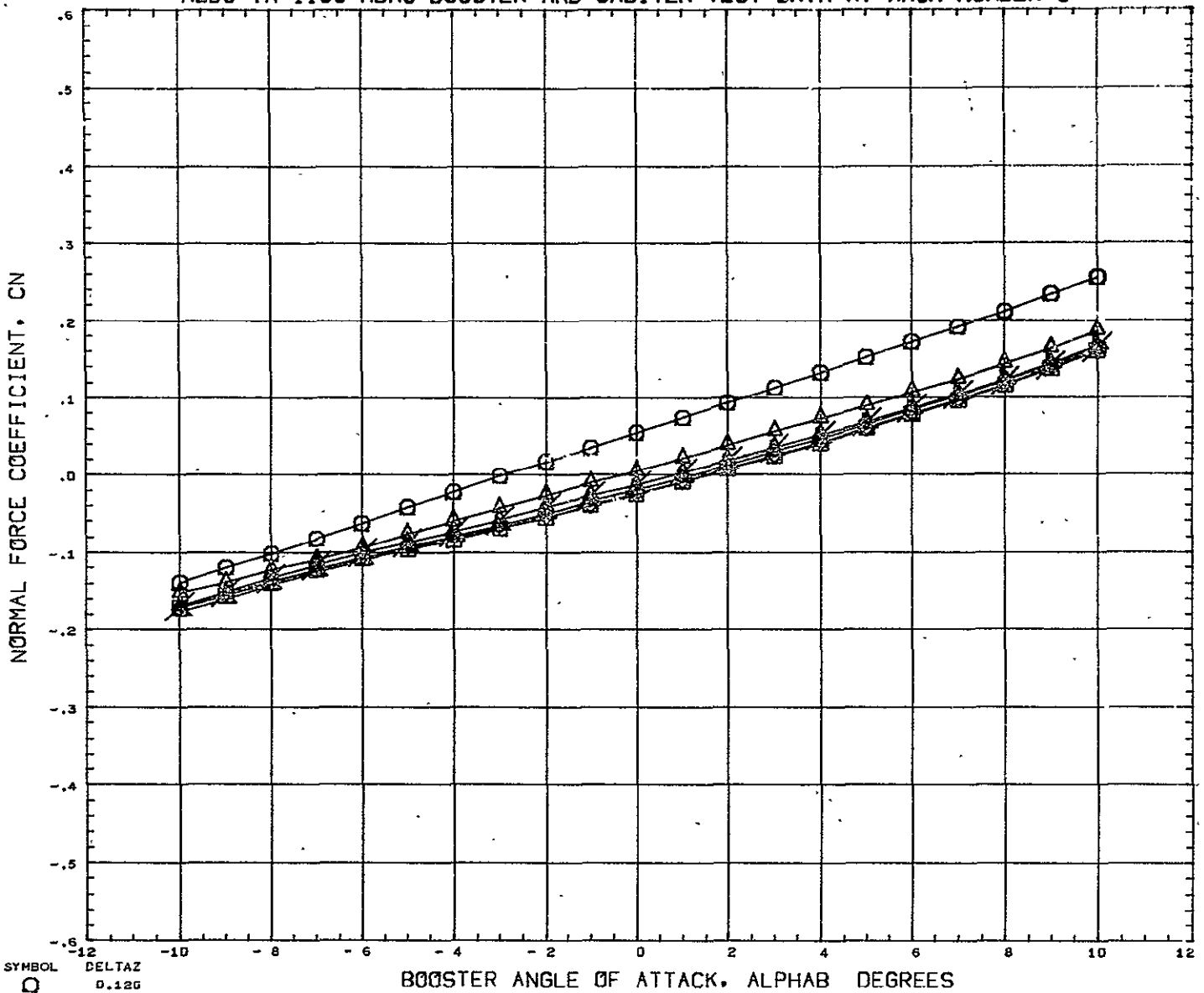

SYMBOL ○ □ △ ◇ ×	DELTAZ 0.120 0.151 0.182 0.228 0.352 10.000	<table border="0" style="width: 100%;"> <tr> <th colspan="4" style="text-align: center;">PARAMETRIC VALUES</th> </tr> <tr> <td>BSTPOW</td> <td>100.000</td> <td>ORBPOW</td> <td>100.000</td> </tr> <tr> <td>DELTAZ</td> <td>0.522</td> <td>ALPHA1</td> <td>0.000</td> </tr> <tr> <td>MACH</td> <td>5.010</td> <td>ELVBST</td> <td>0.000</td> </tr> <tr> <td>ELVORB</td> <td>0.000</td> <td>BETA</td> <td>0.000</td> </tr> </table>	PARAMETRIC VALUES				BSTPOW	100.000	ORBPOW	100.000	DELTAZ	0.522	ALPHA1	0.000	MACH	5.010	ELVBST	0.000	ELVORB	0.000	BETA	0.000	<table border="0" style="width: 100%;"> <tr> <th colspan="3" style="text-align: center;">REFERENCE INFORMATION</th> </tr> <tr> <td>REFS</td> <td>23.6890</td> <td>SQ IN</td> </tr> <tr> <td>REFL</td> <td>4.1930</td> <td>IN</td> </tr> <tr> <td>REFB</td> <td>6.5000</td> <td>IN</td> </tr> <tr> <td>XMRP</td> <td>4.9170</td> <td>IN</td> </tr> <tr> <td>YMRP</td> <td>0.0000</td> <td>IN</td> </tr> <tr> <td>ZMRP</td> <td>1.3900</td> <td>IN</td> </tr> <tr> <td>SCALE</td> <td>0.0055</td> <td></td> </tr> </table>	REFERENCE INFORMATION			REFS	23.6890	SQ IN	REFL	4.1930	IN	REFB	6.5000	IN	XMRP	4.9170	IN	YMRP	0.0000	IN	ZMRP	1.3900	IN	SCALE	0.0055	
PARAMETRIC VALUES																																															
BSTPOW	100.000	ORBPOW	100.000																																												
DELTAZ	0.522	ALPHA1	0.000																																												
MACH	5.010	ELVBST	0.000																																												
ELVORB	0.000	BETA	0.000																																												
REFERENCE INFORMATION																																															
REFS	23.6890	SQ IN																																													
REFL	4.1930	IN																																													
REFB	6.5000	IN																																													
XMRP	4.9170	IN																																													
YMRP	0.0000	IN																																													
ZMRP	1.3900	IN																																													
SCALE	0.0055																																														
REFERENCE FILE																																															

# AEDC VA 1163 MDAC BOOSTER AND ORBITER TEST DATA AT MACH NUMBER 5

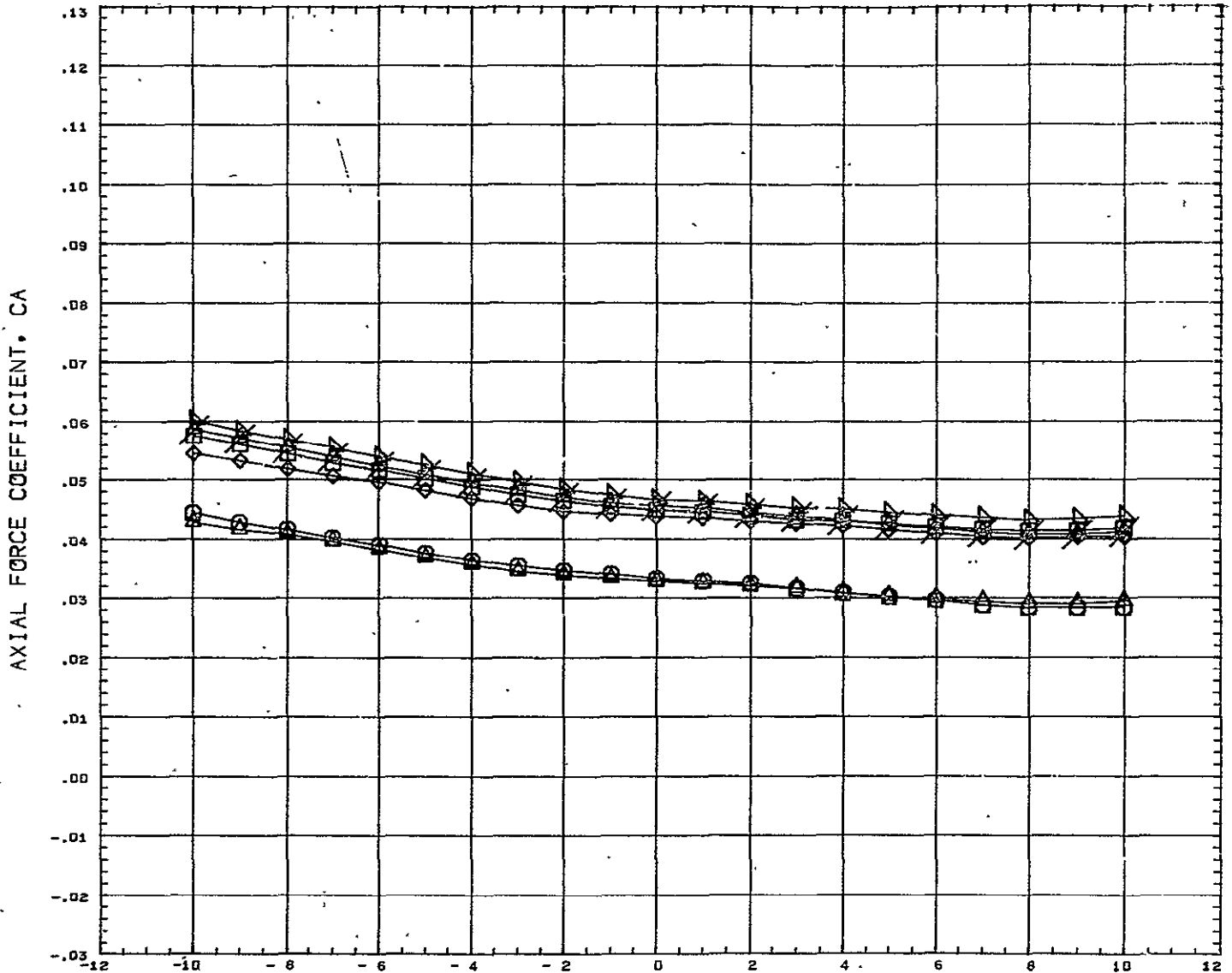

SYMBOL ○ □ △	DELTAZ 0.120 0.151 0.182 0.228 0.352 10.000	PARAMETRIC VALUES 3STPOW 100.000 ORBPCW 100.000 DELTAX 0.522 ALPHAI 0.000 MACH 5.010 ELVBST 0.000 ELVORB 0.000 BETA 0.000	REFERENCE INFORMATION REFS 23.6890 SQ IN REFL 4.1930 IN REFB 6.5000 IN XMRP 4.9170 IN YMRP 0.0000 IN ZMRP 1.3900 IN SCALE 0.0055
REFERENCE FILE			

# AEDC VA 1163 MDAC BOOSTER AND ORBITER TEST DATA AT MACH NUMBER 5

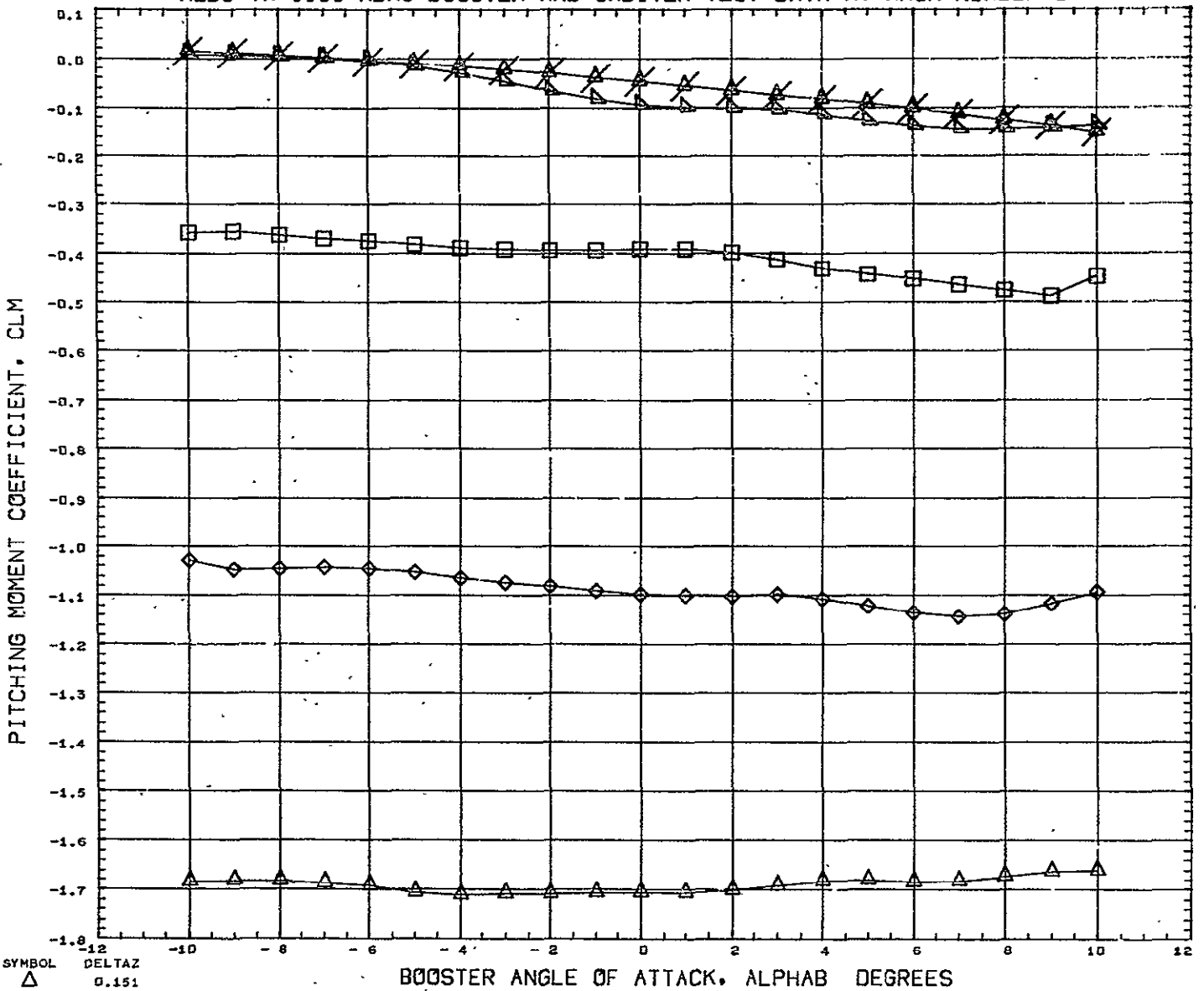

SYMBOL △ ◇ □ x	DELTAX 0.151 0.182 0.228 0.352 10.000	PARAMETRIC VALUES ASTPOW 100.000    ORBPOW 100.000 DELTAX - 0.391    ALPHA1 5.000 MACH 5.010    ELVBST 0.000 ELVORB 0.000    BETA 0.000	REFERENCE INFORMATION REFS 23.6890    SQ IN REFL 4.1930    IN REFB 6.5000    IN XMRP 4.9110    IN YHRF 0.0000    IN ZHRF 1.3900    IN SCALE 0.0055
REFERENCE FILE			

AEDC VA 1163 MDAC BOOSTER AND ORBITER TEST DATA AT MACH NUMBER 4.5

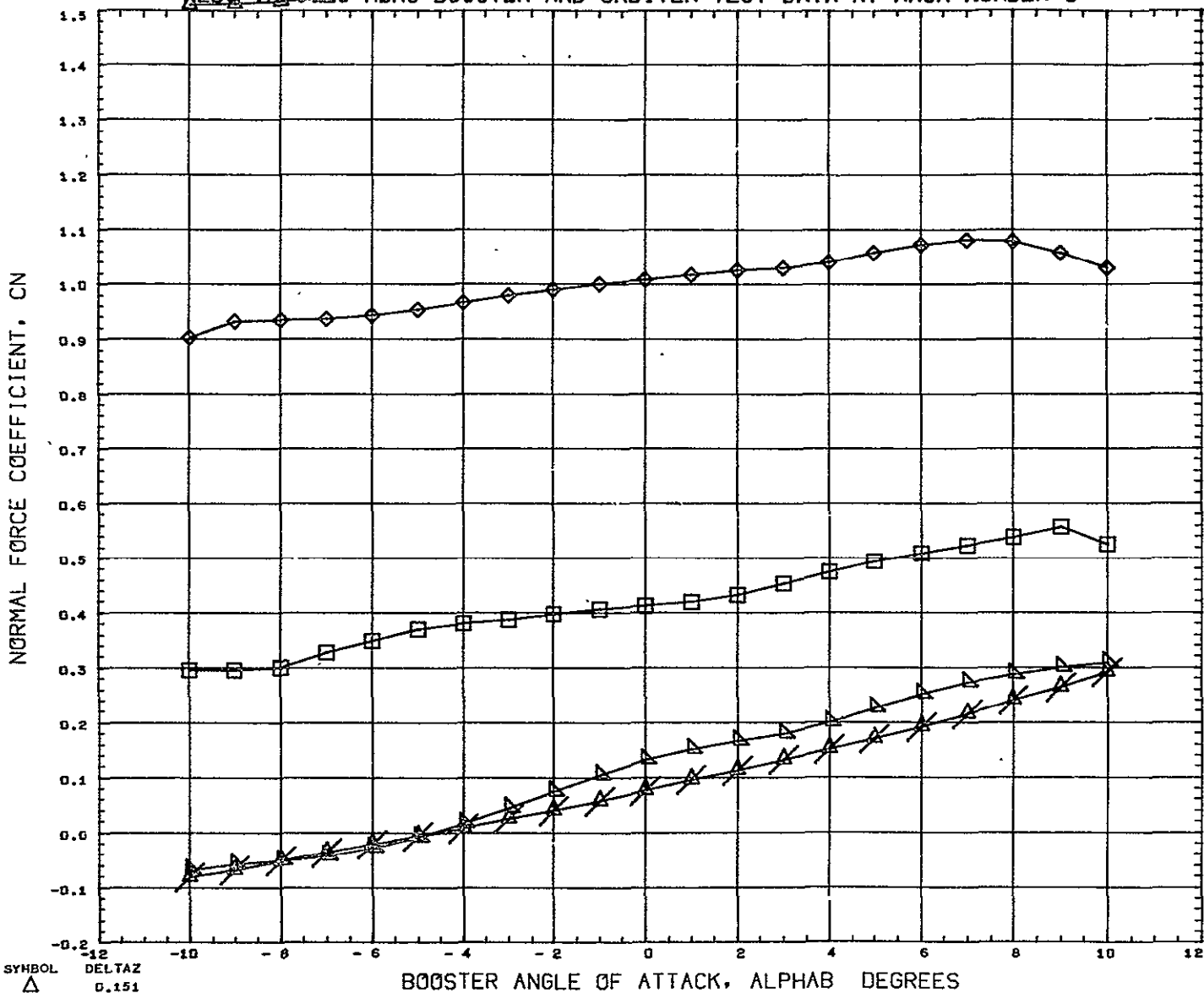

SYMBOL	DELTA Z	PARAMETRIC VALUES				REFERENCE INFORMATION		
△	0.151	BSTPOW	100.000	ORBPOW	100.000	REFS	23.6890	SQ IN
◇	0.182	DELTA X	- 0.391	ALPHA I	5.000	REFL	4.1930	IN
□	0.228	MACH	5.010	ELV BST	0.000	REFB	6.5000	IN
△	0.352	ELVORB	0.000	BETA	0.000	XMP	4.9170	IN
△	10.000					YMRP	0.0000	IN
						ZMRP	1.3900	IN
						SCALE	0.0055	

REFERENCE FILE

# AEDC VA 1163 MDAC BOOSTER AND ORBITER TEST DATA AT MACH NUMBER 5

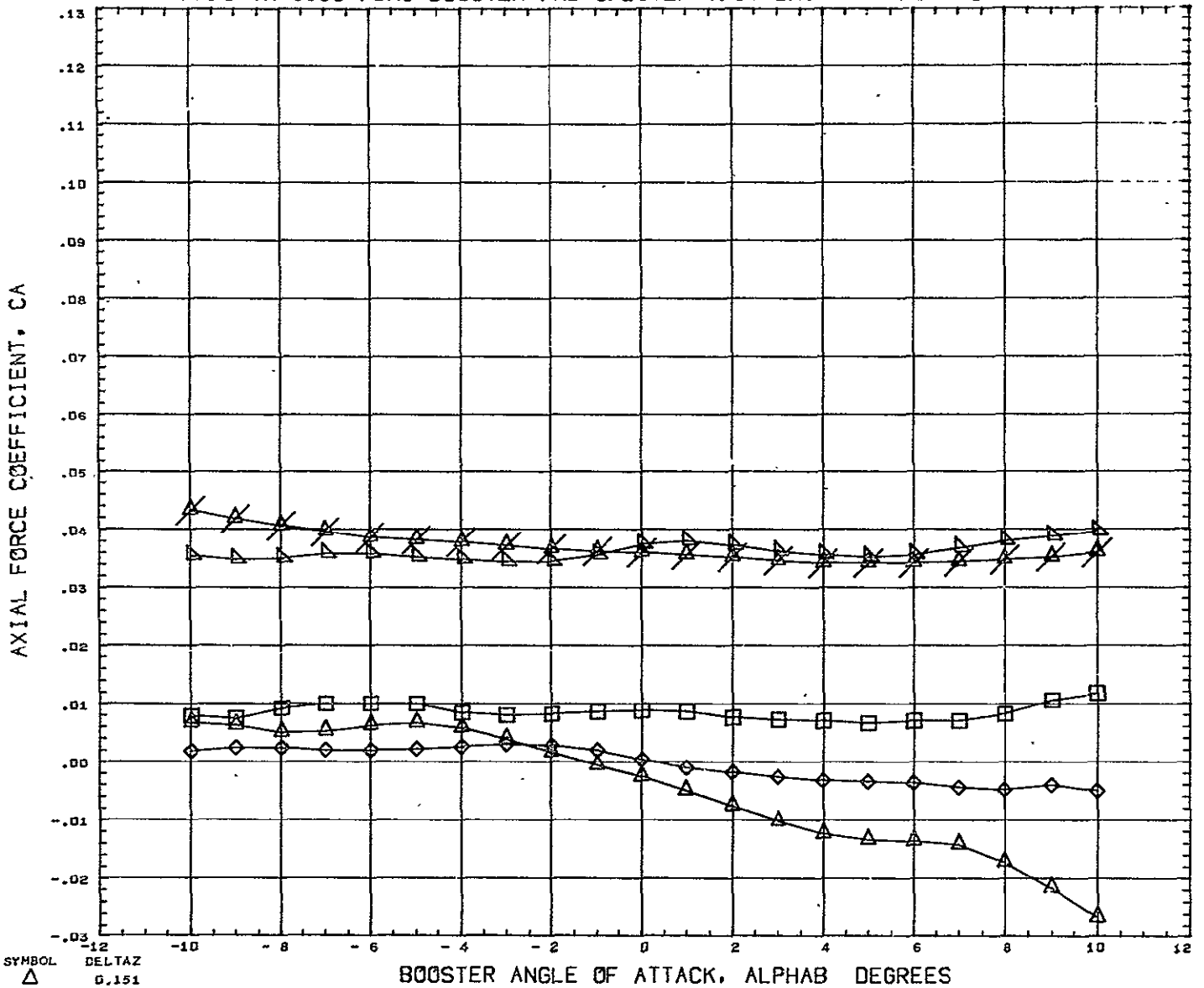

SYMBOL △ ◊ ◻ ▽ ×	DELTAZ 0.151 0.182 0.228 0.352 10.000	PARAMETRIC VALUES BSTPOW 100.000 ORBPOW 100.000 DELTAX - 0.391 ALPHAI 5.000 MACH 5.010 ELVBST 0.000 ELVORB 0.000 BETA 0.000	REFERENCE INFORMATION REFS 23.6890 SQ IN REFL 4.1930 IN REFB 6.5000 IN XMRP 4.9170 IN YMRP 0.0000 IN ZHRP 1.3900 IN SCALE 0.0055
REFERENCE FILE			

# AEDC VA 1163 MDAC BOOSTER AND ORBITER TEST DATA AT MACH NUMBER 5

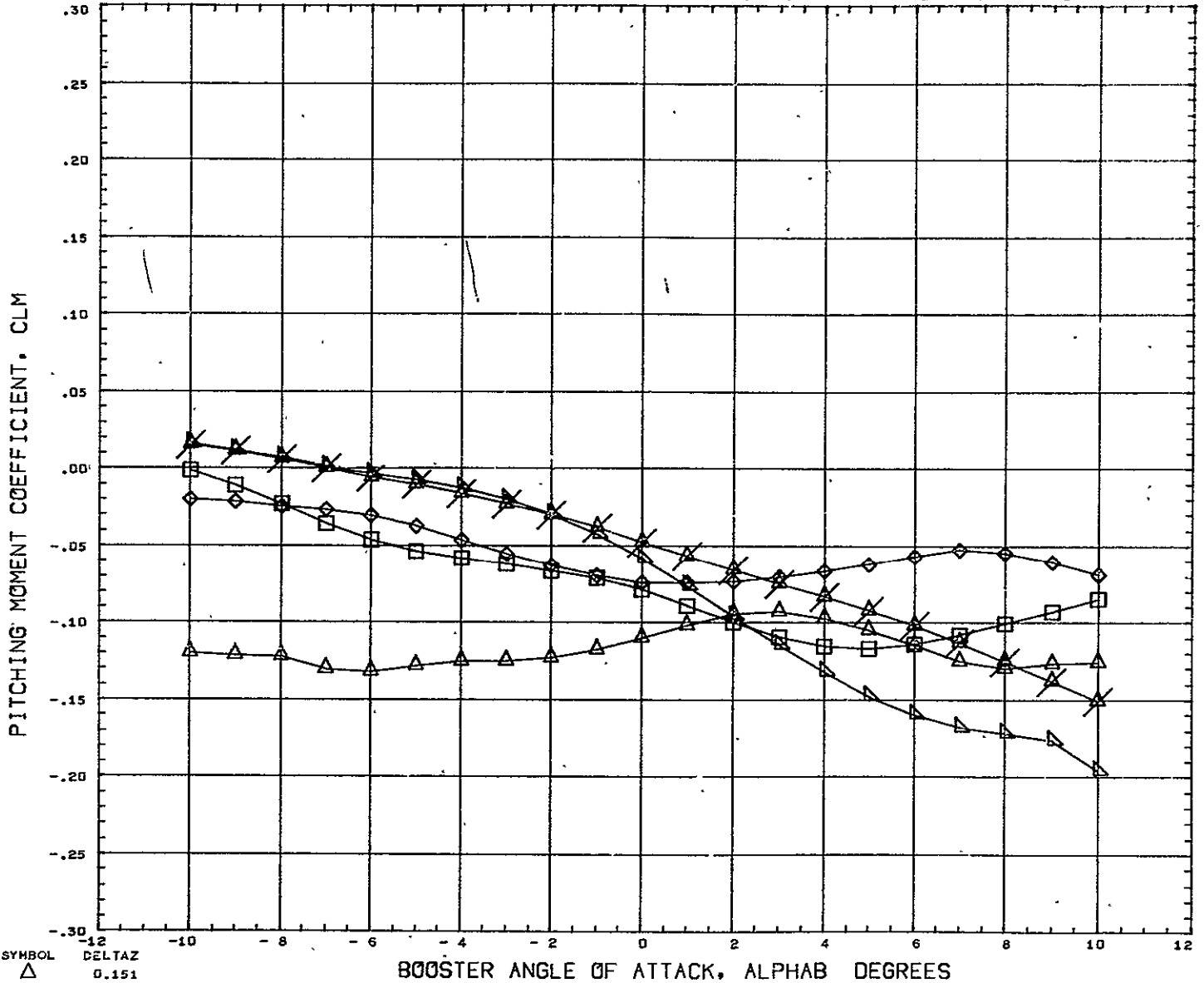

SYMBOL △ ◊ □ × ▽	DELTAZ 0.151 0.182 0.228 0.352 10.000	<b>PARAMETRIC VALUES</b> BSTFOW - 100.000    ORBFOW    100.000 DELTAX - 0.143    ALPHAI - 5.000 MACH    5.010    ELVBST    0.000 ELVORB    0.000    BETA      0.300	<b>REFERENCE INFORMATION</b> REFS    23.6890    SQ IN REFL    4.1930    IN REFB    6.5000    IN XMRP    4.8170    IN YMRP    0.0000    IN ZMRP    1.3900    IN SCALE    0.0055
---------------------------------	--	---	---

REFERENCE FILE

# AEDC VA 1163 MDAC BOOSTER AND ORBITER TEST DATA AT MACH NUMBER 5

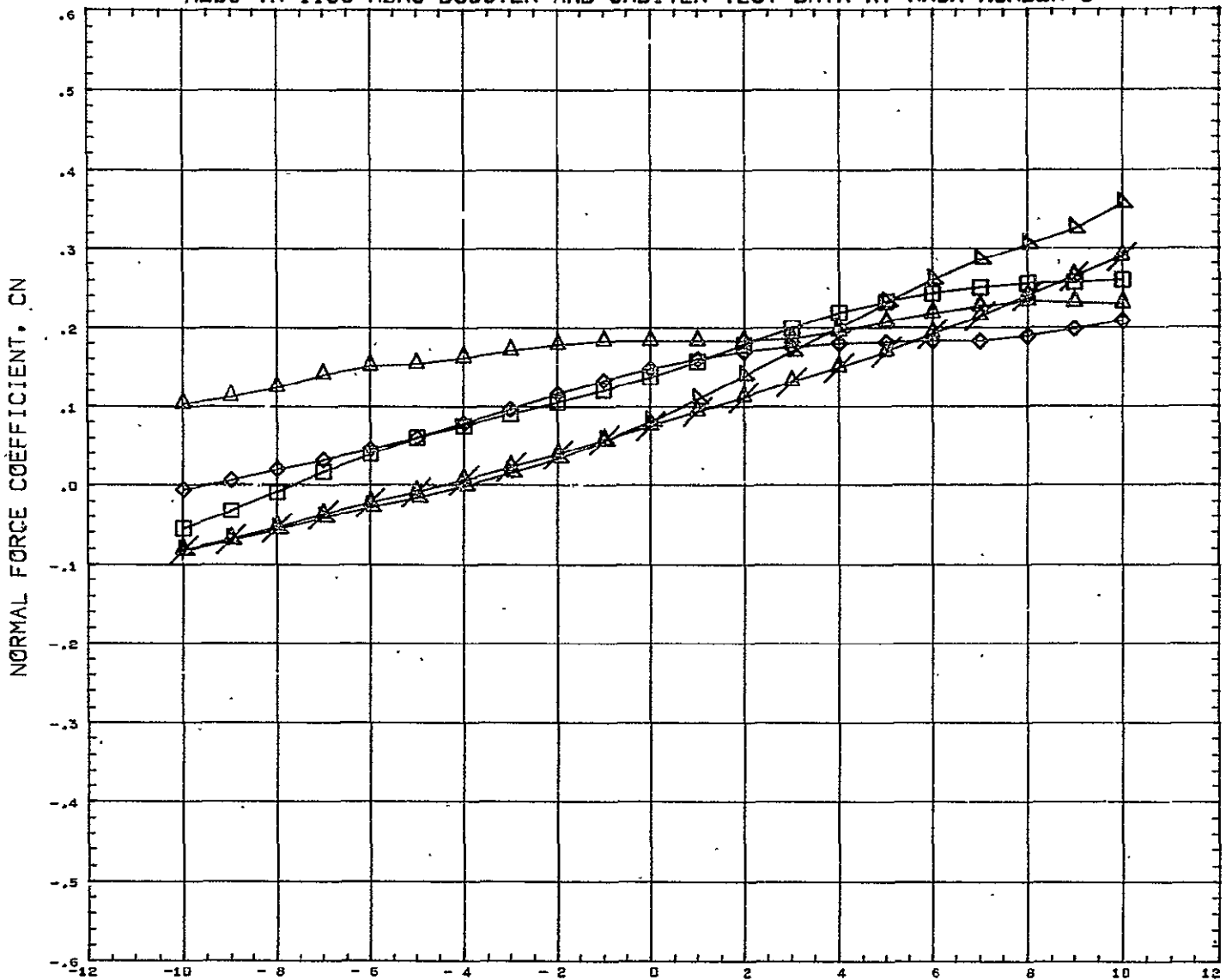

SYMBOL △ ◇ □ ○ ×	DELTAZ 0.151 0.182 0.228 0.352 10.000	PARAMETRIC VALUES BSTPOW 100.000 ORBPOW 100.000 DELTAX - 0.143 ALPHAI 5.000 MACH 5.010 ELVBST 0.000 ELVORB 0.000 BETA 0.000	REFERENCE INFORMATION REFS 23.689D SQ IN REFL 4.1930 IN REFB 6.5000 IN XMRF 4.9175 IN YMRF 0.0000 IN ZMRF 1.3900 IN SCALE -0.0055
---------------------------------	--	---	--

REFERENCE FILE

# AEDC VA 1163 MDAC BOOSTER AND ORBITER TEST DATA AT MACH NUMBER 5

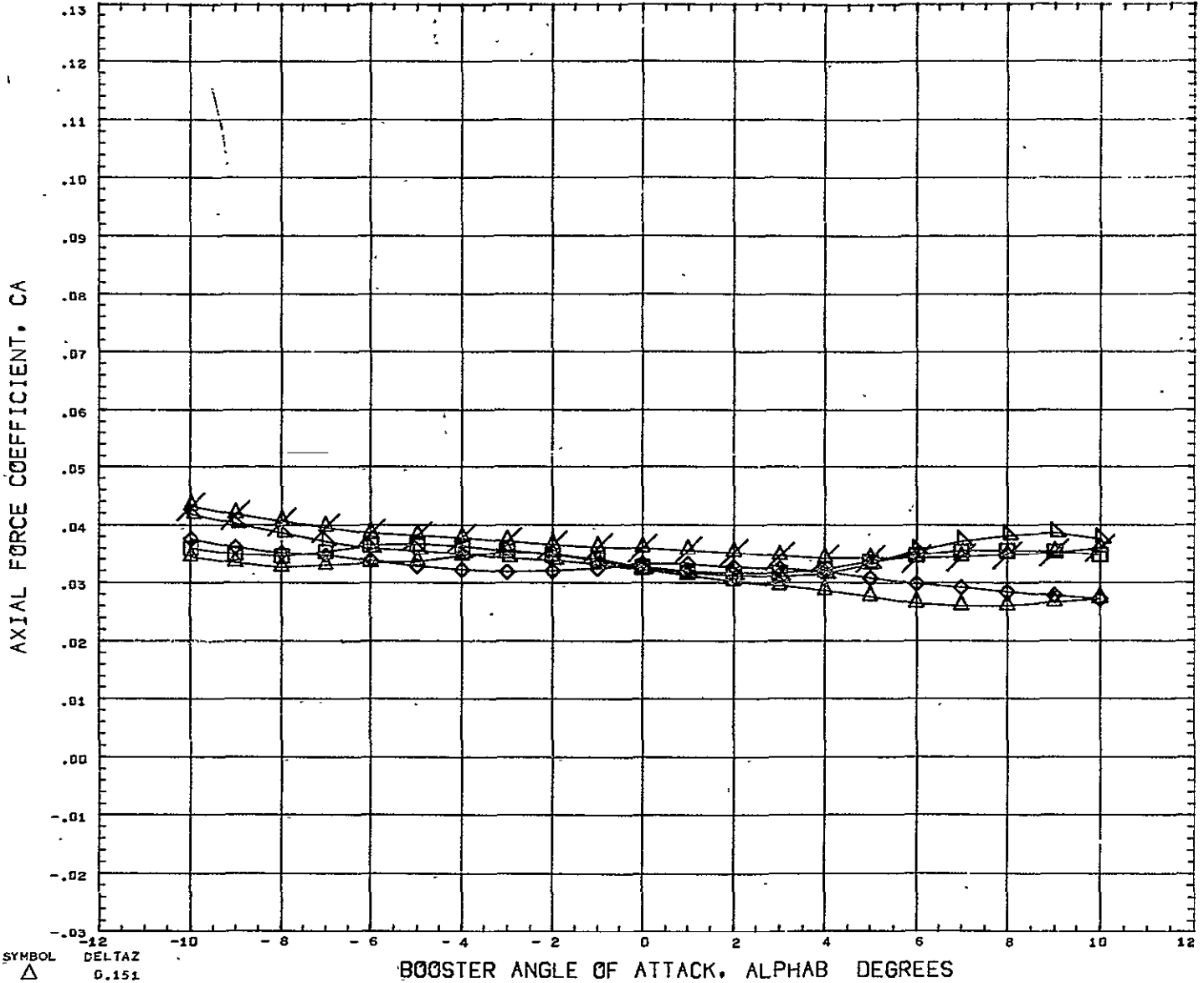

SYMBOL	DELTA Z	PARAMETRIC VALUES			
△	0.151				
◇	0.182				
□	0.228	RSTPOW	100.000	ORBPOW	100.000
×	0.352	DELTA X	0.143	ALPHA I	5.000
	10.000	MACH	5.010	ELVBST	0.000
		ELVORB	0.000	BETA	0.000

REFERENCE INFORMATION		
REFS	23.6890	SQ IN
REFL	4.1930	IN
REFB	6.5000	IN
XMRF	4.9170	IN
YMRF	0.0000	IN
ZMRF	1.3900	IN
SCALE	0.0055	

REFERENCE FILE



# AEDC VA 1163 MDAC BOOSTER AND ORBITER TEST DATA AT MACH NUMBER 5

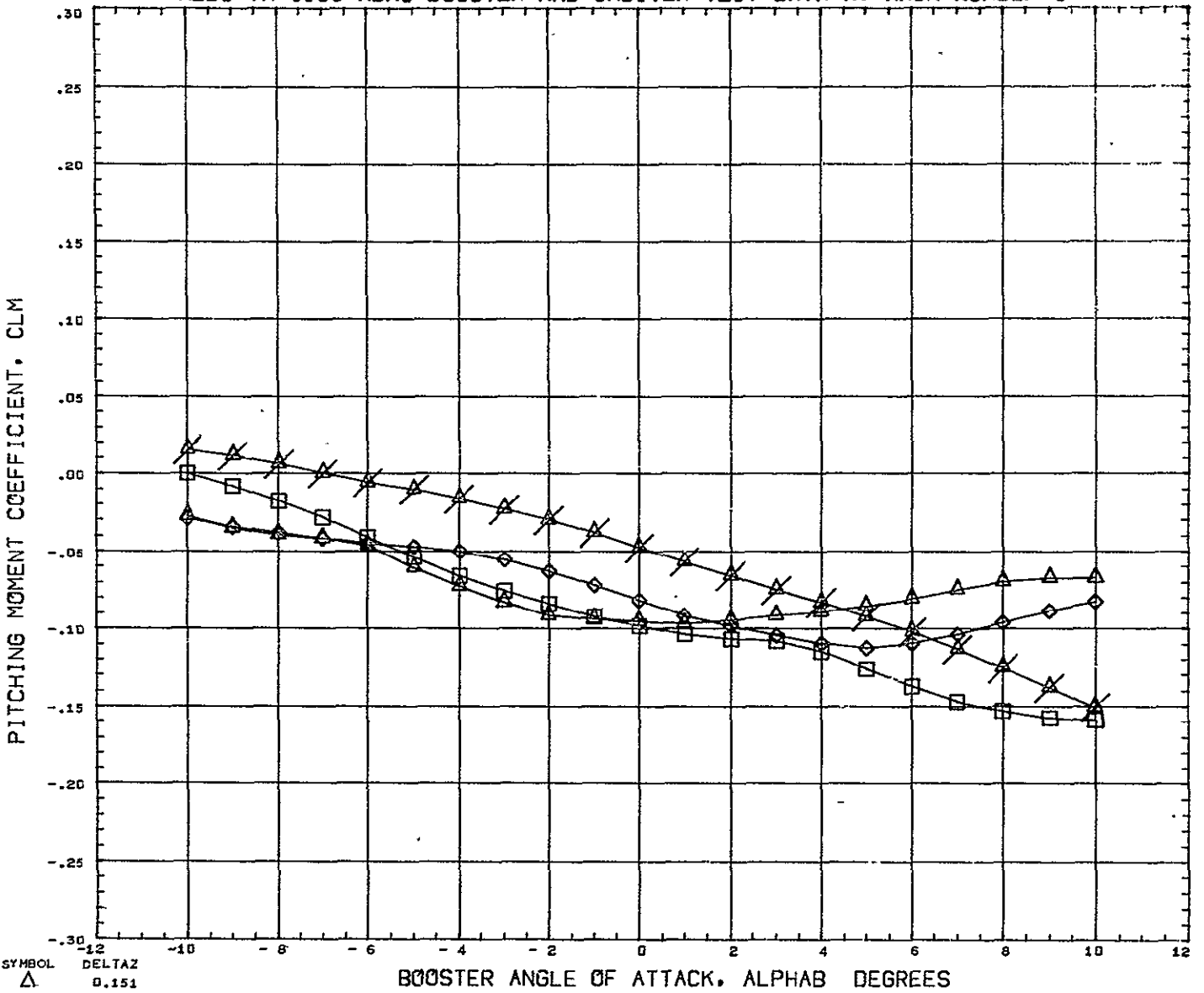

SYMBOL    DELTAZ  
 △        0.151  
 ◇        0.182  
 □        0.228  
 ✕        10.000

PARAMETRIC VALUES

BSTPOW	100.000	ORBPOW	100.000
DELTAZ	0.019	ALPHA1	5.000
MACH	5.010	ELVBST	0.000
ELVORB	0.000	BETA	0.000

REFERENCE INFORMATION

REFS	23.6890	SQ IN
REFL	4.1930	IN
REFR	6.5000	IN
XMRP	4.9170	IN
YMRP	0.0000	IN
ZMRF	1.3900	IN
SCALE	0.0055	

REFERENCE FILE

# AEDC VA 1163 MDAC BOOSTER AND ORBITER TEST DATA AT MACH NUMBER 5

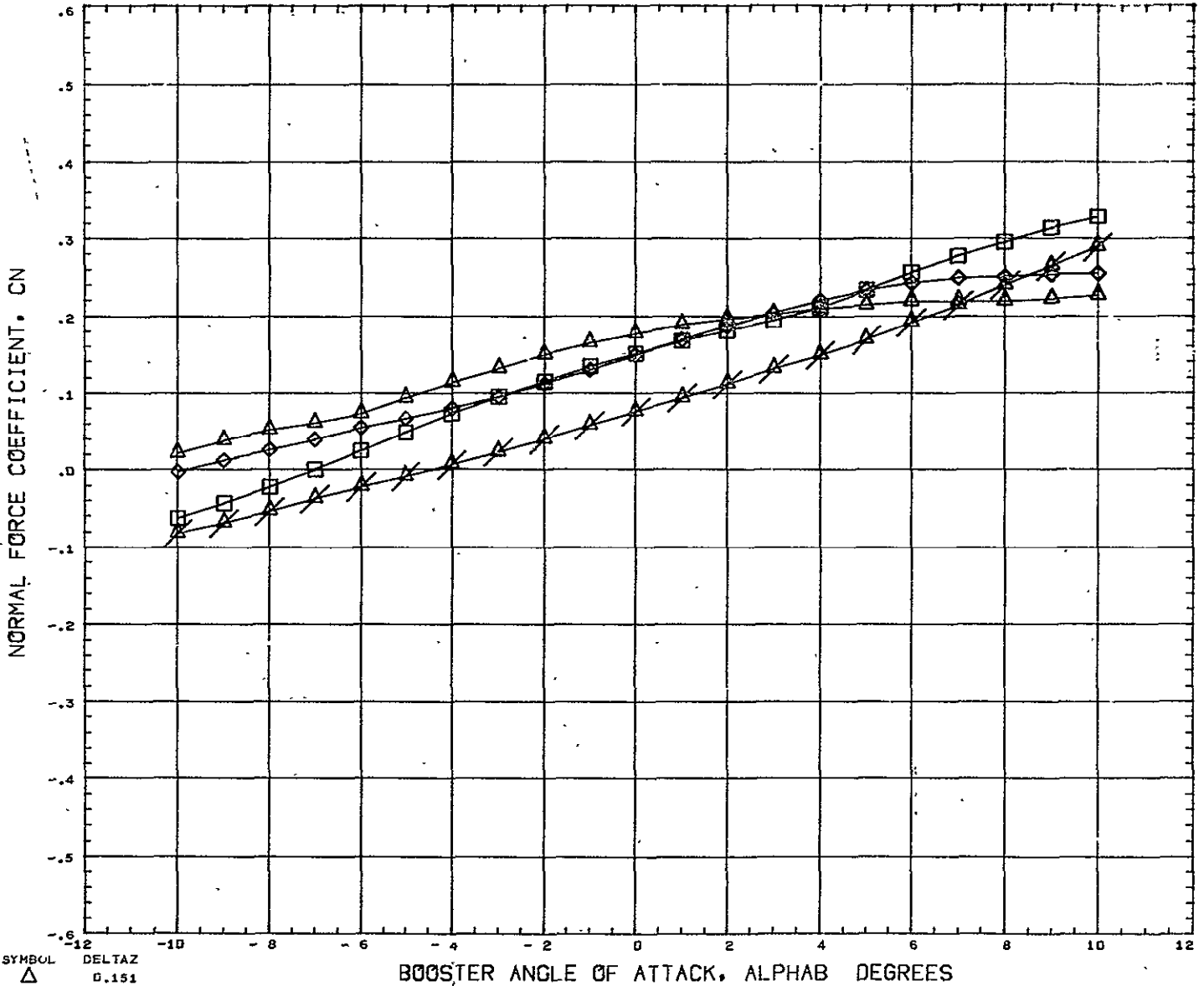

SYMBOL	△ 0.151 ◇ 0.182 □ 0.228 × 10.000	PARAMETRIC VALUES CSTPOW 100.000 ORBPOW 100.000 DELTAX 0.019 ALPHAI 5.000 MACH 5.010 ELVBST 0.000 ELVORB 0.000 BETA 0.000	REFERENCE INFORMATION REFS 23.6000 SQ IN REFL 4.1930 IN REFB 6.5000 IN XMRP 4.9170 IN YMRP 0.0000 IN ZMRP 1.3900 IN SCALE 0.0055
	REFERENCE FILE		

# AEDC VA 1163 MDAC BOOSTER AND ORBITER TEST DATA AT MACH NUMBER 5

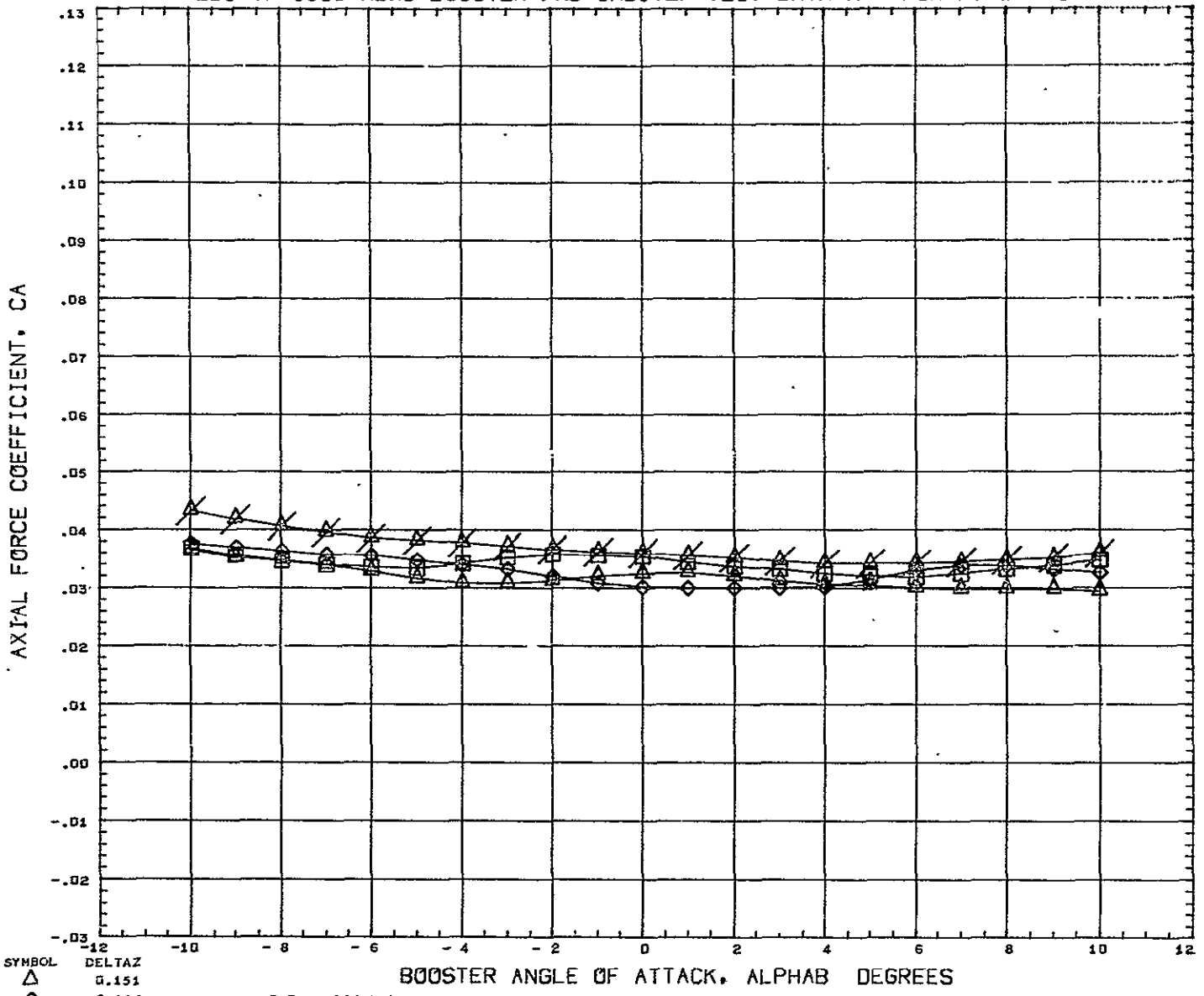

SYMBOL  
 △  
 ◇  
 □  
 ×

DELTA Z  
 0.151  
 0.182  
 0.228  
 10.000

PARAMETRIC VALUES  
 BSTFOW 100.000 ORBPOW 100.000  
 DELTAX - 0.019 ALPHAI 5.000  
 MACH 5.010 ELVBST 0.000  
 ELVORB 0.000 BETA 0.000

REFERENCE INFORMATION  
 REFS 23.6890 SQ IN  
 REFL 4.1930 IN  
 REFB 6.5000 IN  
 XMRP 4.9170 IN  
 YMRP 0.0000 IN  
 ZMRP 1.3900 IN  
 SCALE 0.0055

REFERENCE FILE

# AEDC VA 1163 MDAC BOOSTER AND ORBITER TEST DATA AT MACH NUMBER 5

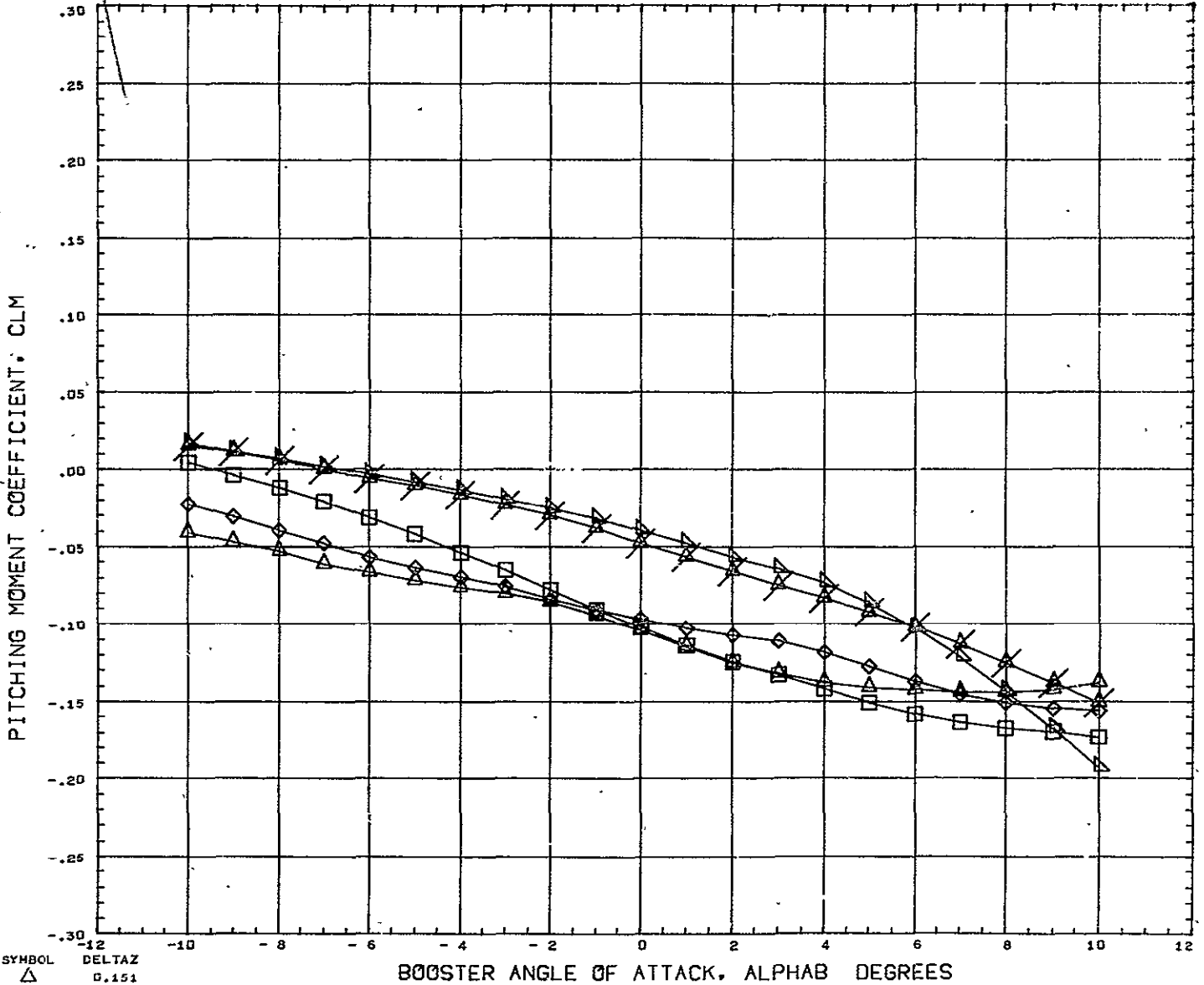

SYMBOL	DELTA Z	PARAMETRIC VALUES				REFERENCE INFORMATION		
△	0.151	BSTPOW	100.000	ORBPOW	100.000	REFS	23.6890	SQ IN
◇	0.182	DELTA X	0.104	ALPHA I	5.000	REFL	4.1930	IN
□	0.228	MACH	5.010	ELVBST	0.000	REFB	6.5000	IN
×	10.000	ELVORB	0.000	BETA	0.000	XMRP	4.9170	IN
▽						YMRP	0.0000	IN
						ZMRP	1.3900	IN
						SCALE	0.0055	

REFERENCE FILE

# AEDC VA 1163 MDAC BOOSTER AND ORBITER TEST DATA AT MACH NUMBER 5

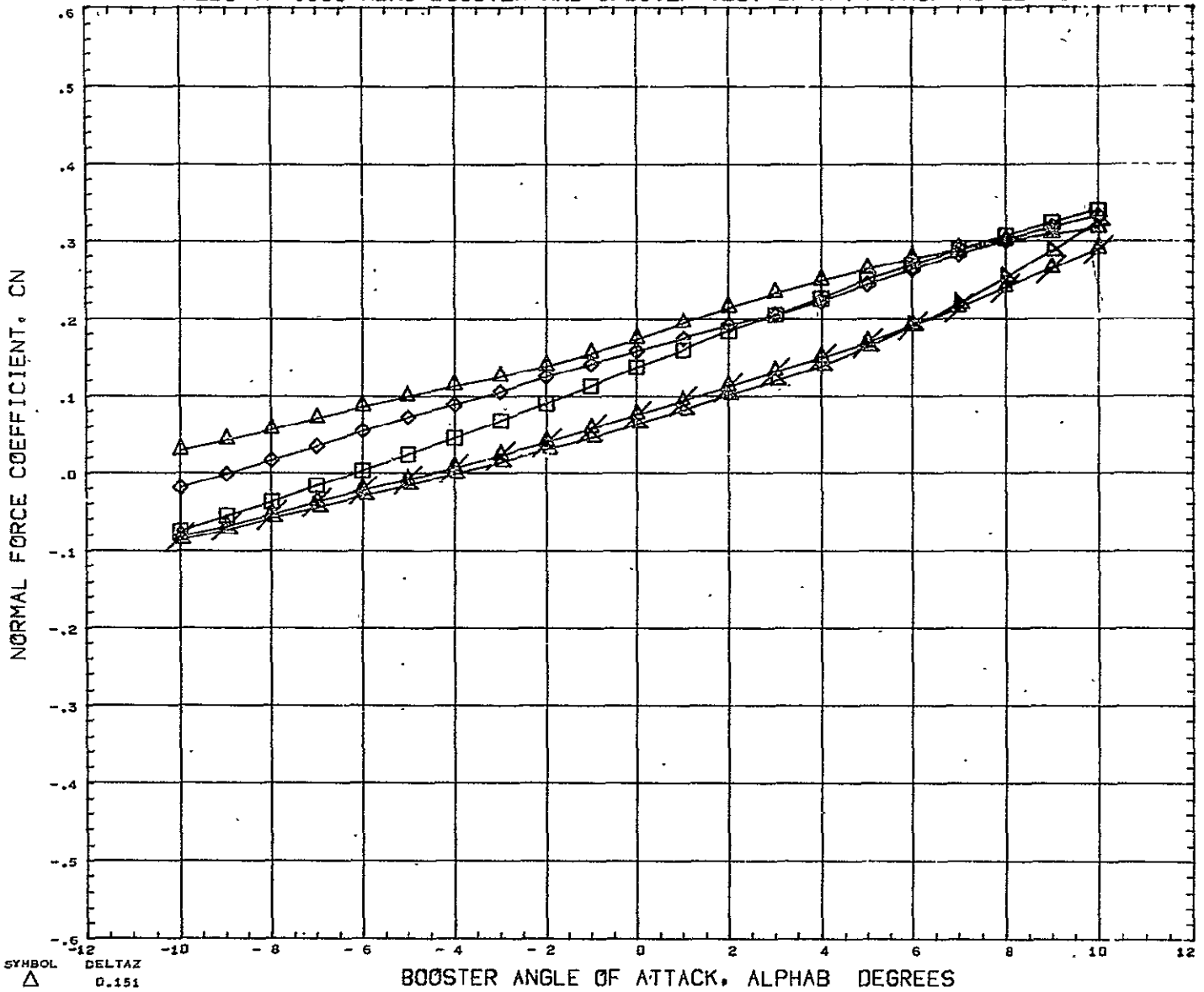

SYMBOL  
 △  
 ◇  
 □  
 ○  
 ×

DELTAZ  
 0.151  
 0.182  
 0.228  
 0.352  
 10.000

PARAMETRIC VALUES  
 BSTPOW 100.000 ORBPOW 100.000  
 DELTAX 0.104 ALPHAI 5.000  
 MACH 5.010 ELVBST 0.000  
 ELVORB 0.000 BETA 0.000

REFERENCE FILE

REFERENCE INFORMATION  
 REFS 23.6890 SQ IN  
 REFL 4.1930 IN  
 REFB 6.5000 IN  
 XMRF 4.9170 IN  
 YMRF 0.0000 IN  
 ZMRF 1.3900 IN  
 SCALE 0.0055

# AEDC VA 1163 MDAC BOOSTER AND ORBITER TEST DATA AT MACH NUMBER 5

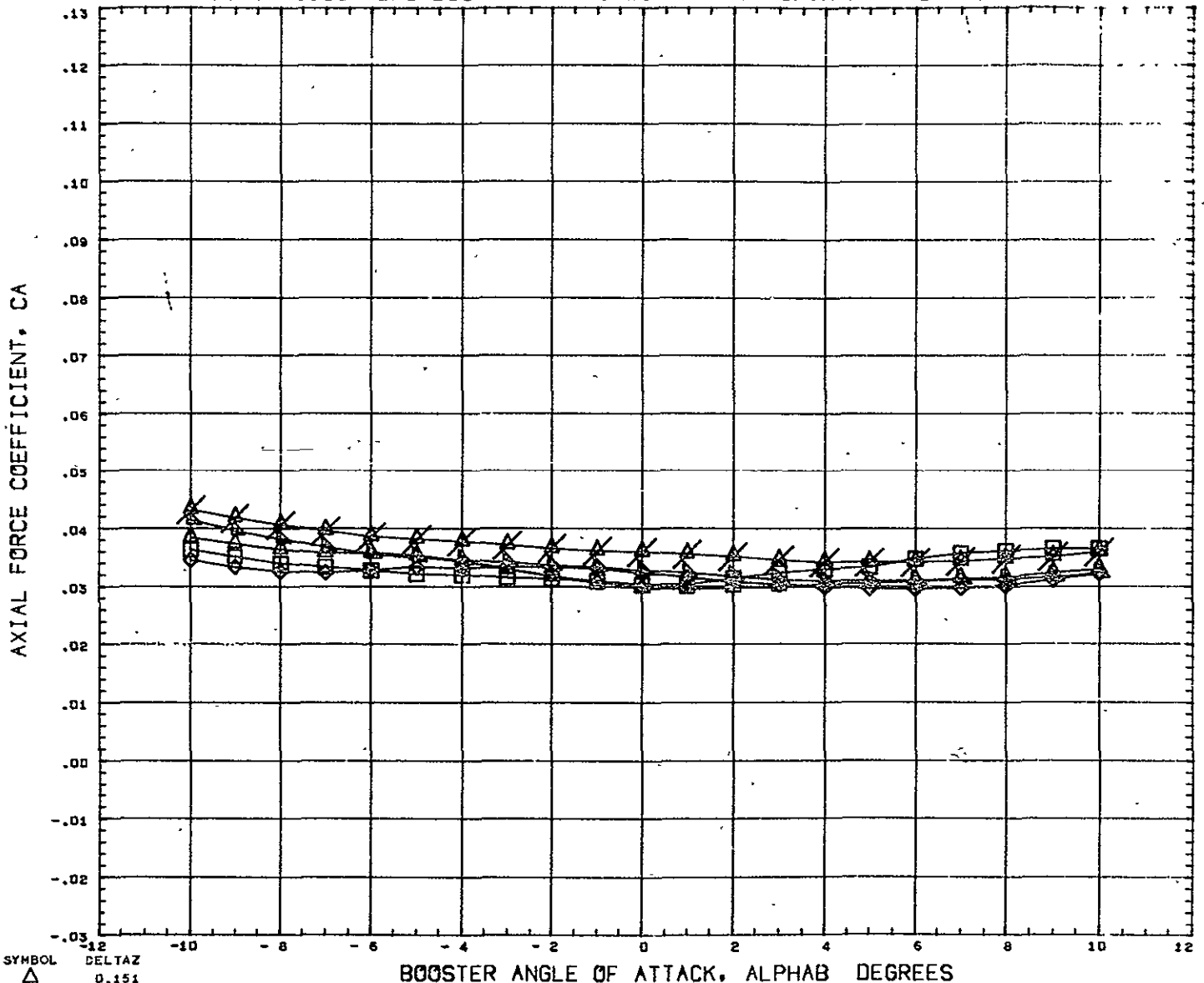

SYMBOL △ ◇ □ ○ ×	DELTAZ 0.151 0.182 0.226 0.392 10.000	<table border="0" style="width: 100%;"> <tr> <th colspan="4" style="text-align: left; padding-left: 20px;">PARAMETRIC VALUES</th> </tr> <tr> <td style="padding-right: 10px;">BSTPOW</td> <td>100.000</td> <td style="padding-right: 10px;">ORBPOW</td> <td>100.000</td> </tr> <tr> <td style="padding-right: 10px;">DELTAI</td> <td>0.104</td> <td style="padding-right: 10px;">ALPHAI</td> <td>5.000</td> </tr> <tr> <td style="padding-right: 10px;">MACH</td> <td>5.010</td> <td style="padding-right: 10px;">ELVBST</td> <td>0.000</td> </tr> <tr> <td style="padding-right: 10px;">ELVORB</td> <td>0.000</td> <td style="padding-right: 10px;">BETA</td> <td>0.000</td> </tr> </table>	PARAMETRIC VALUES				BSTPOW	100.000	ORBPOW	100.000	DELTAI	0.104	ALPHAI	5.000	MACH	5.010	ELVBST	0.000	ELVORB	0.000	BETA	0.000	<table border="0" style="width: 100%;"> <tr> <th colspan="3" style="text-align: left;">REFERENCE INFORMATION</th> </tr> <tr> <td style="padding-right: 10px;">REFS</td> <td>23.6890</td> <td>SQ IN</td> </tr> <tr> <td style="padding-right: 10px;">REFL</td> <td>4.1930</td> <td>IN</td> </tr> <tr> <td style="padding-right: 10px;">REFB</td> <td>6.5000</td> <td>IN</td> </tr> <tr> <td style="padding-right: 10px;">XMRP</td> <td>4.317L</td> <td>IN</td> </tr> <tr> <td style="padding-right: 10px;">YMRP</td> <td>0.0000</td> <td>IN</td> </tr> <tr> <td style="padding-right: 10px;">ZMRP</td> <td>1.3900</td> <td>IN</td> </tr> <tr> <td style="padding-right: 10px;">SCALE</td> <td>0.0055</td> <td></td> </tr> </table>	REFERENCE INFORMATION			REFS	23.6890	SQ IN	REFL	4.1930	IN	REFB	6.5000	IN	XMRP	4.317L	IN	YMRP	0.0000	IN	ZMRP	1.3900	IN	SCALE	0.0055	
PARAMETRIC VALUES																																															
BSTPOW	100.000	ORBPOW	100.000																																												
DELTAI	0.104	ALPHAI	5.000																																												
MACH	5.010	ELVBST	0.000																																												
ELVORB	0.000	BETA	0.000																																												
REFERENCE INFORMATION																																															
REFS	23.6890	SQ IN																																													
REFL	4.1930	IN																																													
REFB	6.5000	IN																																													
XMRP	4.317L	IN																																													
YMRP	0.0000	IN																																													
ZMRP	1.3900	IN																																													
SCALE	0.0055																																														
REFERENCE FILE																																															

# AEDC VA 1163 MDAC BOOSTER AND ORBITER TEST DATA AT MACH NUMBER 5

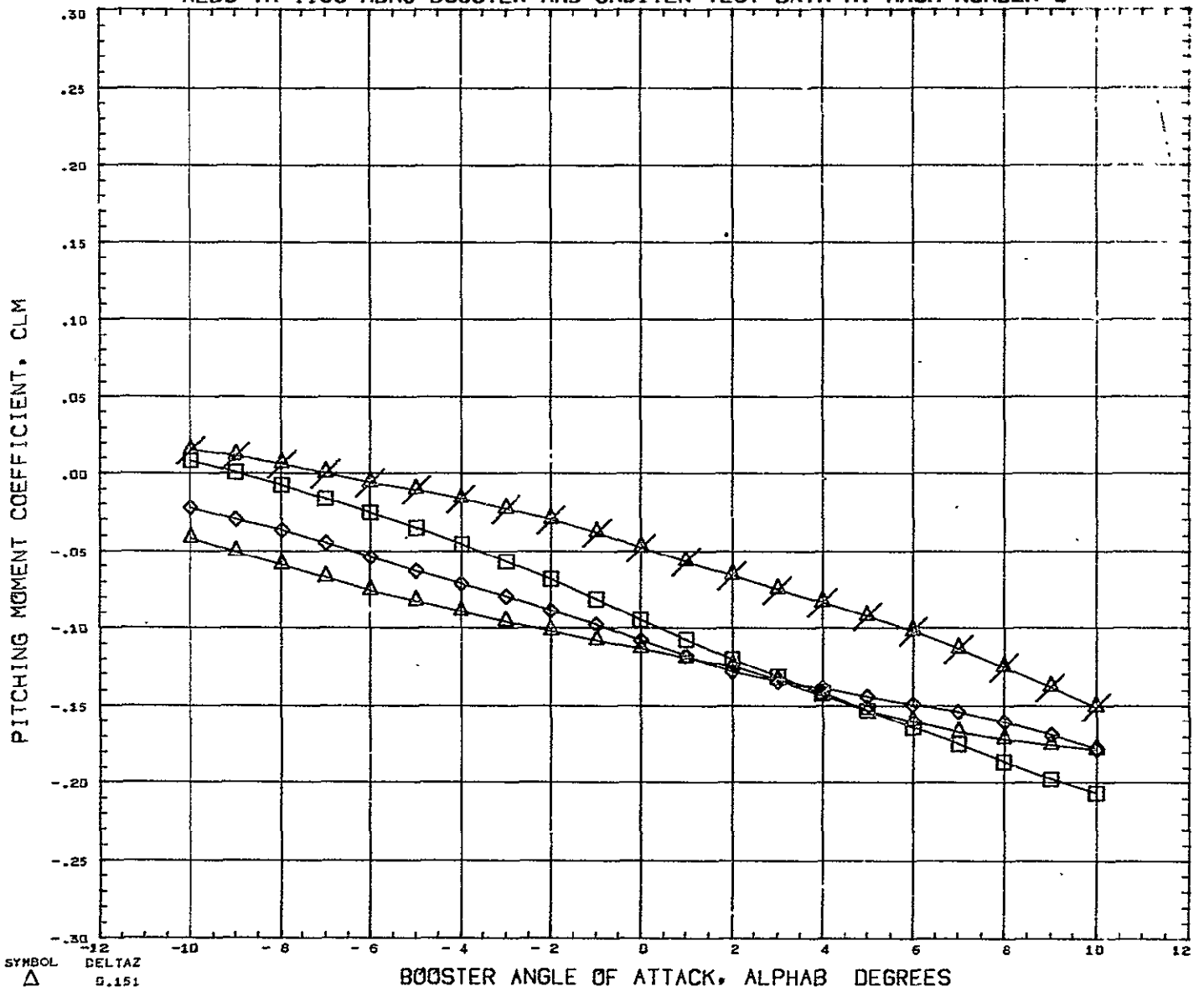

SYMBOL  
 △  
 ◇  
 □  
 ×

DELTA Z  
 0.151  
 0.182  
 0.228  
 10.000

PARAMETRIC VALUES  
 BSTPOW 100.000 ORBPOW 100.000  
 DELTAX 0.166 ALPHAI 5.000  
 MACH 5.010 ELVBST 0.000  
 ELVORB 0.000 BETA 0.000

REFERENCE INFORMATION  
 REFS 23.6890 SQ IN  
 REFL 4.1930 IN  
 REFB 6.5000 IN  
 XMRP 4.9170 IN  
 YMRP 0.0000 IN  
 ZMRP 1.3900 IN  
 SCALE 0.0055

REFERENCE FILE

# AEDC VA 1163 MDAC BOOSTER AND ORBITER TEST DATA AT MACH NUMBER 5

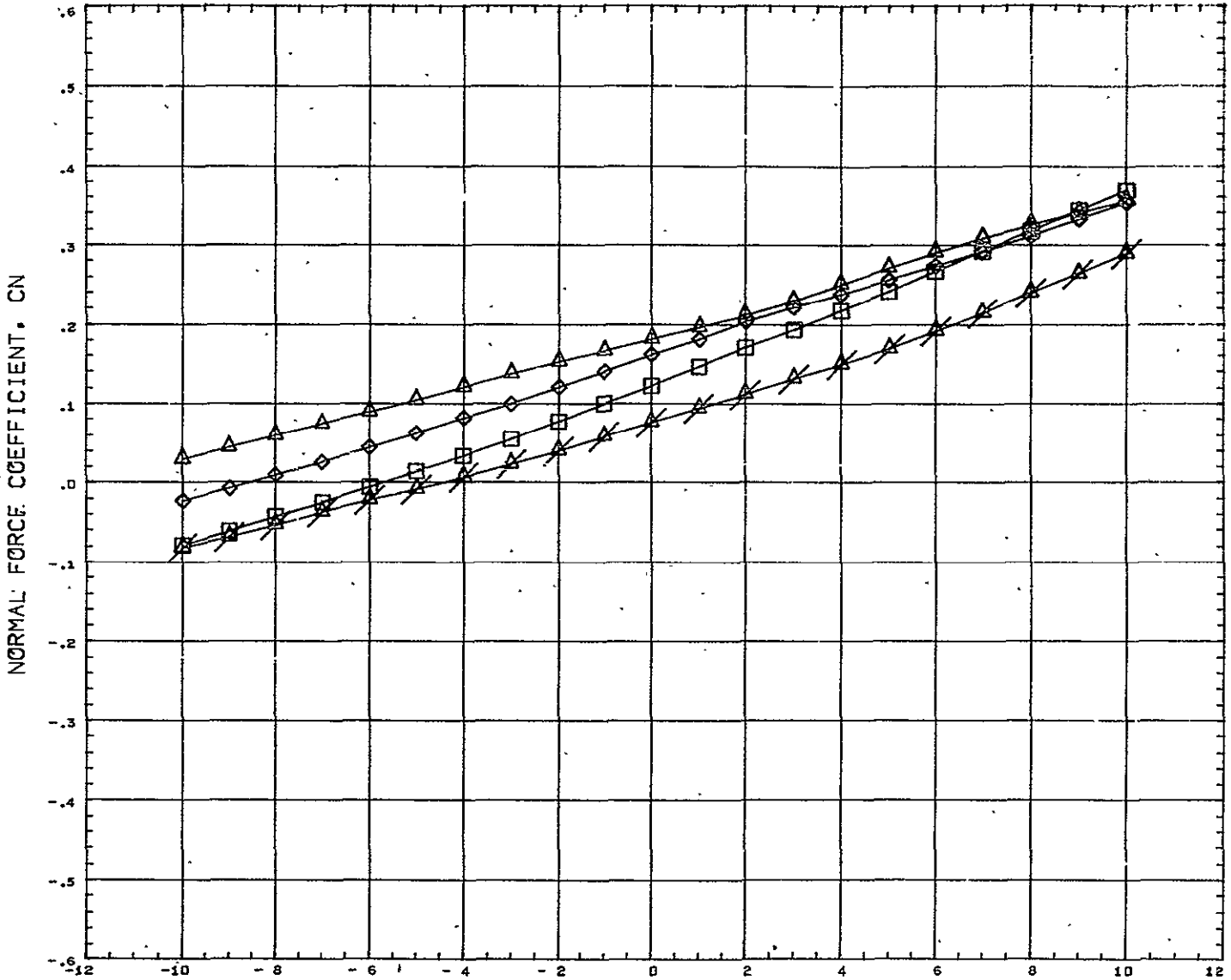

SYMBOL △ ◇ □ ×	DELTAX 0.151 0.182 0.228 10.000	PARAMETRIC VALUES 3STPOW 100.000 ORBPOW 100.000 DELTAX 0.166 ALPHAI 5.000 MACH 5.010 ELVBST 0.000 ELVORB 0.000 BETA 0.000	REFERENCE INFORMATION REFS 23.6890 SQ IN REFL 4.1930 IN REFB 6.5100 IN XMRP 4.9170 IN YMRP 0.0000 IN ZMRP 1.3900 IN SCALE 0.0055
----------------------------	---	---	---

REFERENCE FILE



# AEDC VA 1163 MDAC BOOSTER AND ORBITER TEST DATA AT MACH NUMBER 5

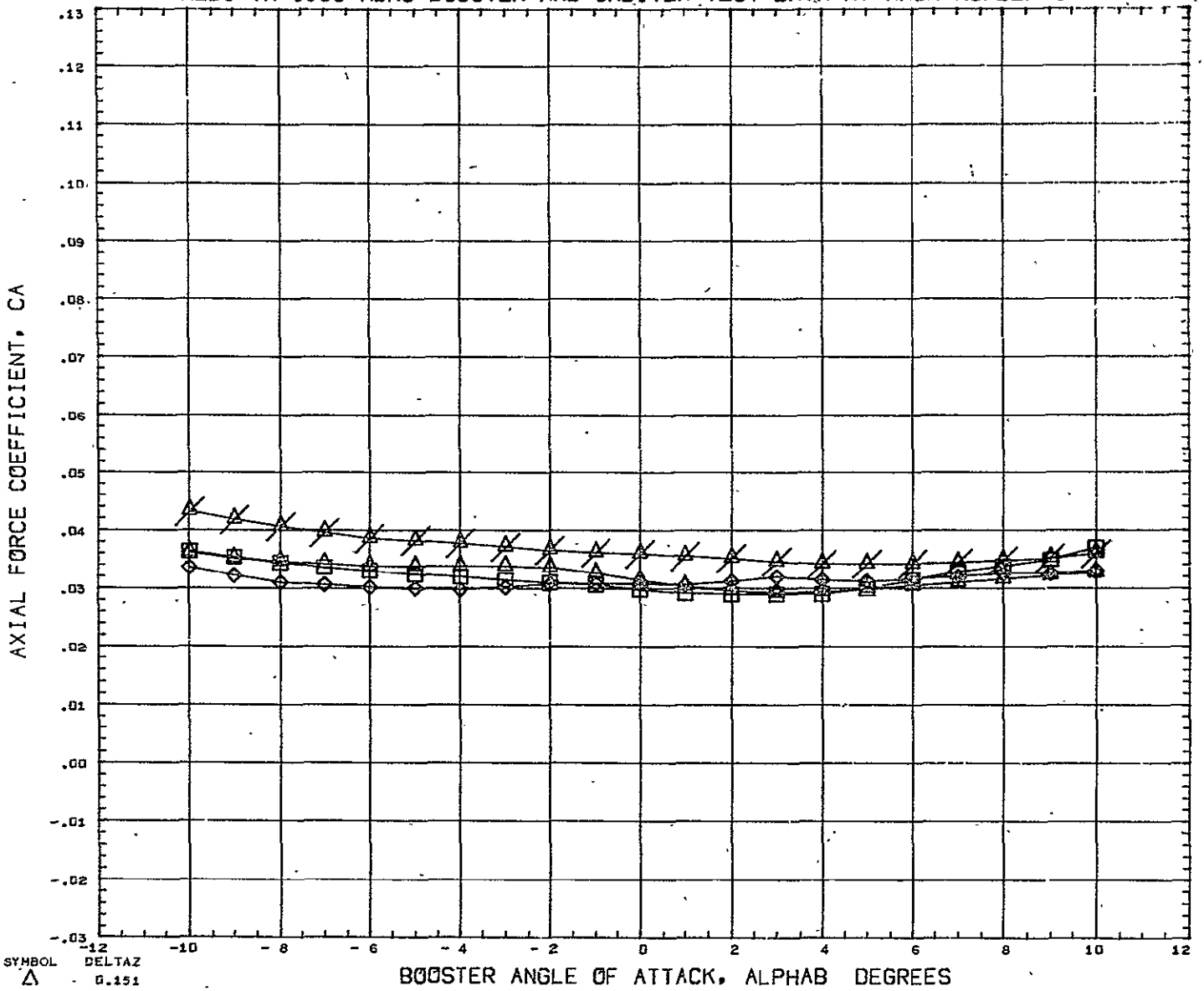

SYMBOL    DELTAZ  
 △        0.151  
 ◇        0.182  
 □        0.228  
 ×        10.000

PARAMETRIC VALUES

θSTPOW	100.000	ORBPOW	100.000
DELTAZ	0.166	ALPHA1	5.000
MACH	5.010	ELVBST	0.000
ELVORB	0.000	BETA	0.000

REFERENCE INFORMATION

REFS	23.6890	SQ IN
REFL	4.1930	IN
REFB	6.5000	IN
XMRP	4.9170	IN
YMRP	0.0000	IN
ZMRP	1.3900	IN
SCALE	0.0055	

REFERENCE FILE

# AEDC VA 1163 MDAC BOOSTER AND ORBITER TEST DATA AT MACH NUMBER 5

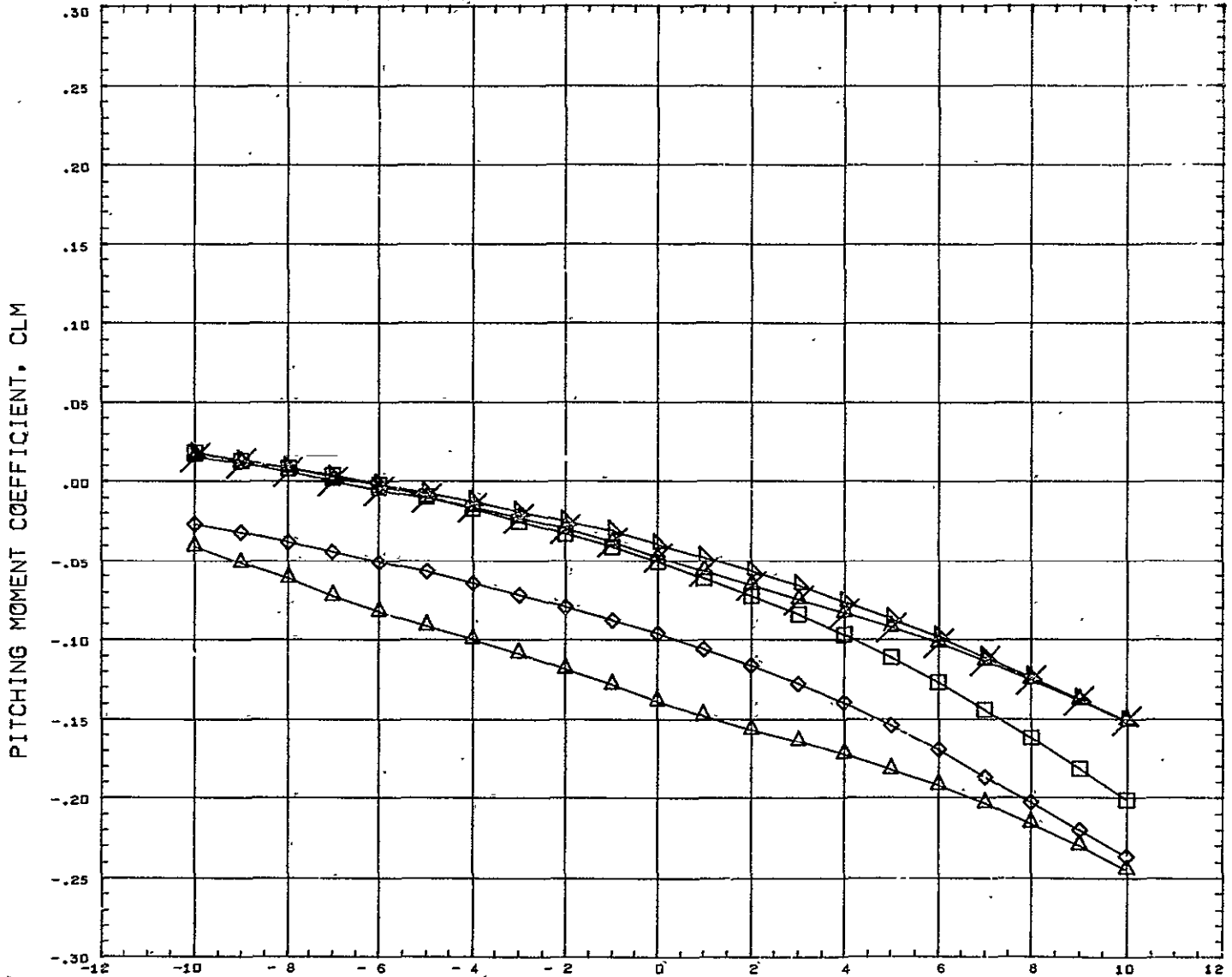

SYMBOL △ ◇ □ × ▽	DELTAX 0.151 0.182 0.228 0.352 10.000	PARAMETRIC VALUES BSTPOW 100.000 ORBPOW 100.000 DELTAX 0.351 ALPHAI 5.000 MACH 5.010 ELVBST 0.000 ELVORB 0.000 BETA 0.000	REFERENCE INFORMATION REFS 23.6890 SQ IN REFL 4.1930 IN REFB 6.5000 IN XMRP 4.9176 IN YMRP 0.0000 IN ZMRP 1.3900 IN SCALE 0.0055
---------------------------------	--	---	---

REFERENCE FILE

# AEDC VA 1163 MDAC BOOSTER AND ORBITER TEST DATA AT MACH NUMBER 5

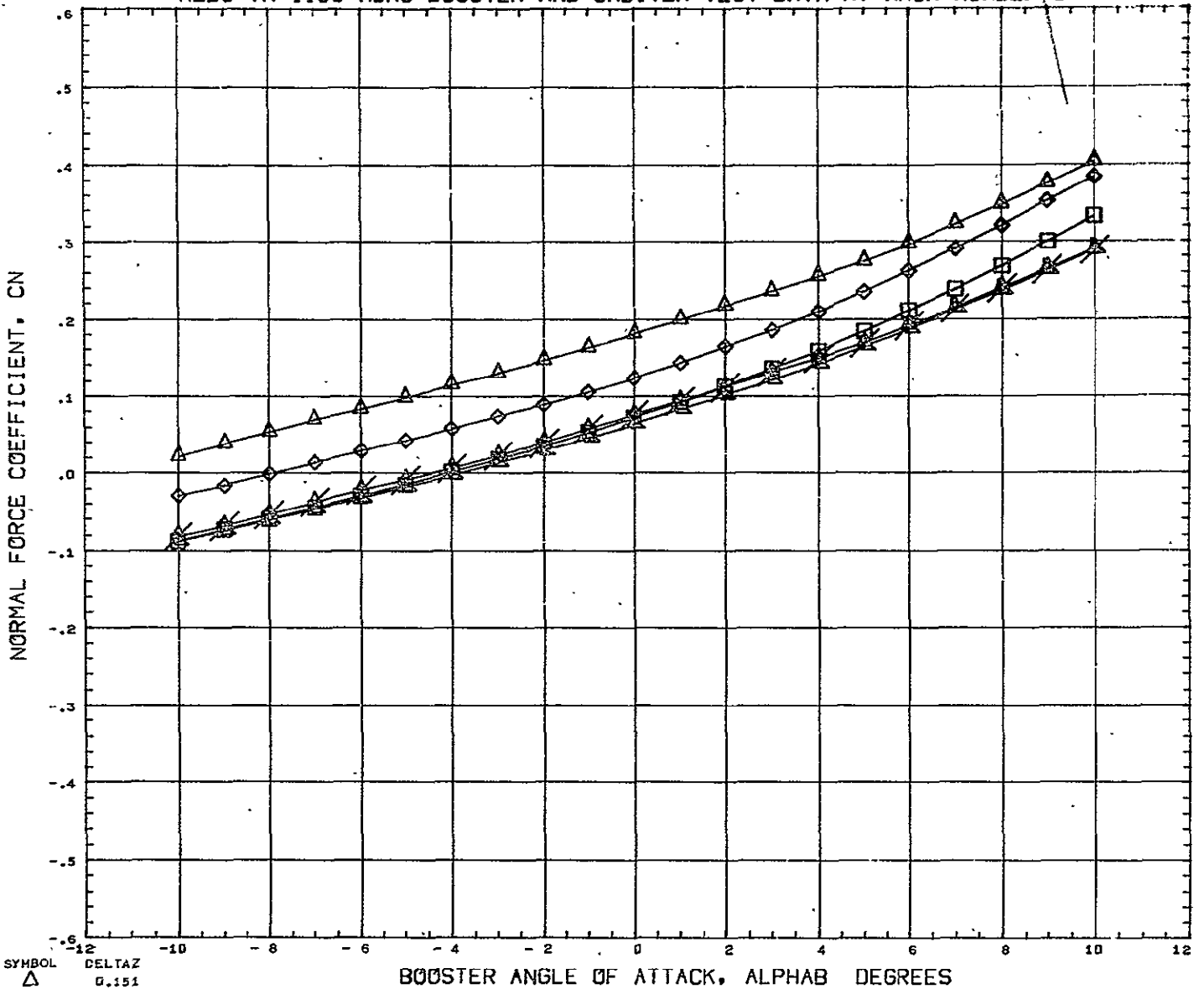

SYMBOL △ ◇ □ ×	DELTAZ 0.151 0.182 0.228 0.352 10.000	<b>PARAMETRIC VALUES</b> BSTPOW 100.000 ORBPOW 100.000 DELTAX 0.351 ALPHAI 5.000 MACH 5.010 ELVBST 0.000 ELVORB 0.000 BETA 0.000	<b>REFERENCE INFORMATION</b> REFS 23.6890 SQ IN REFL 4.1930 IN REFB 6.6900 IN XMRP 4.9170 IN YMRP 0.0000 IN ZHRP 1.3900 IN SCALE 0.0055
----------------------------	--	--	--

REFERENCE FILE



# AEDC VA 1163 MDAC BOOSTER AND ORBITER TEST DATA AT MACH NUMBER 5

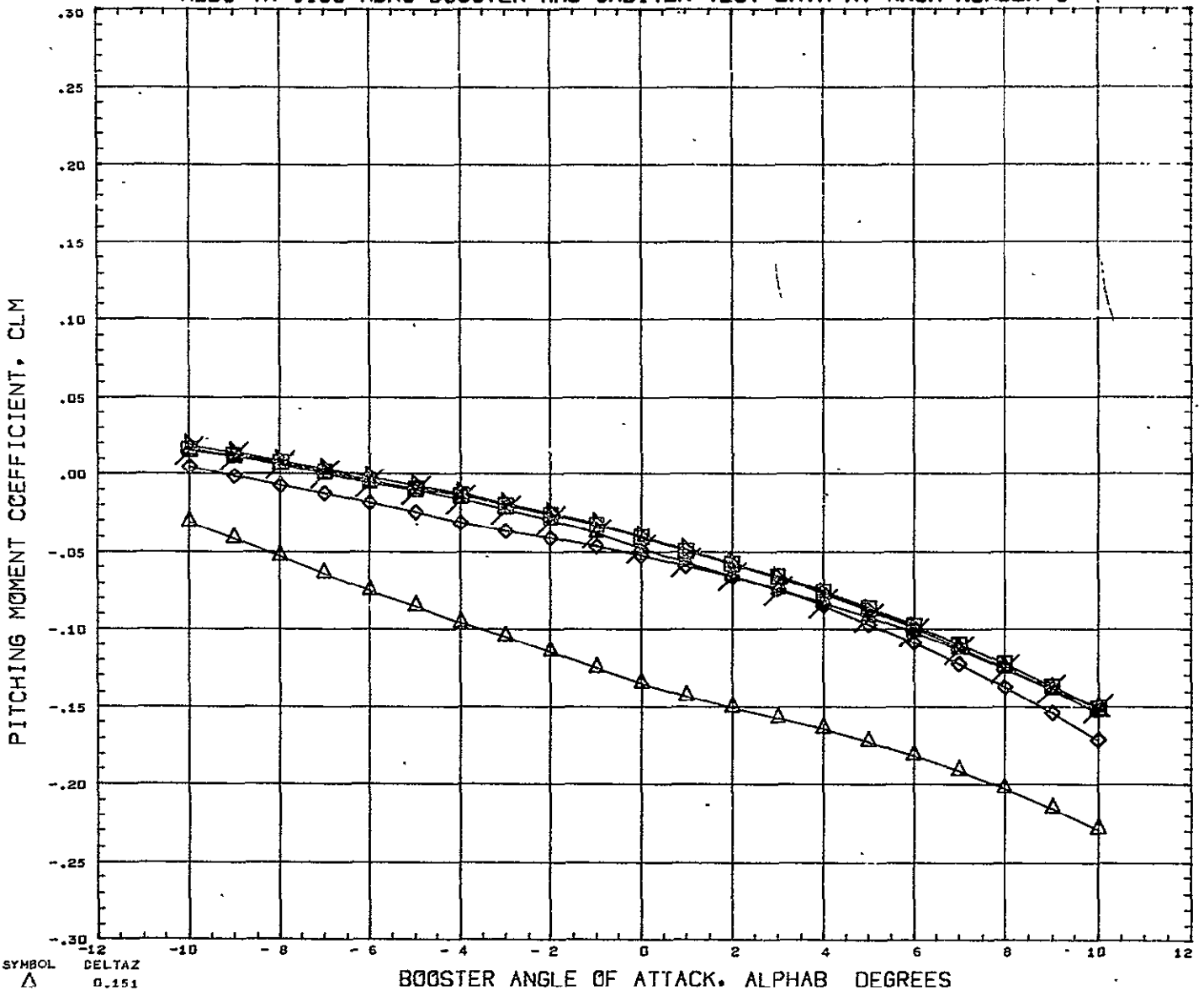

SYMBOL △ ◇ □ ×	DELTAZ 0.151 0.182 0.228 0.352 10.000	<table border="0" style="width: 100%;"> <tr> <th colspan="4" style="text-align: center;">PARAMETRIC VALUES</th> </tr> <tr> <td>BSTPOW</td><td>100.000</td><td>ORBPOW</td><td>100.000</td> </tr> <tr> <td>DELTA X</td><td>0.521</td><td>ALPHA I</td><td>5.000</td> </tr> <tr> <td>MACH</td><td>5.010</td><td>ELVBST</td><td>0.000</td> </tr> <tr> <td>ELVORB</td><td>0.000</td><td>BETA</td><td>0.000</td> </tr> </table>	PARAMETRIC VALUES				BSTPOW	100.000	ORBPOW	100.000	DELTA X	0.521	ALPHA I	5.000	MACH	5.010	ELVBST	0.000	ELVORB	0.000	BETA	0.000	<table border="0" style="width: 100%;"> <tr> <th colspan="3" style="text-align: center;">REFERENCE INFORMATION</th> </tr> <tr> <td>REFS</td><td>23.6890</td><td>SQ IN</td> </tr> <tr> <td>REFL</td><td>4.1930</td><td>IN</td> </tr> <tr> <td>REFB</td><td>6.5000</td><td>IN</td> </tr> <tr> <td>XMRP</td><td>4.9170</td><td>IN</td> </tr> <tr> <td>YMRP</td><td>0.0000</td><td>IN</td> </tr> <tr> <td>ZMRP</td><td>1.3900</td><td>IN</td> </tr> <tr> <td>SCALE</td><td>0.0055</td><td></td> </tr> </table>	REFERENCE INFORMATION			REFS	23.6890	SQ IN	REFL	4.1930	IN	REFB	6.5000	IN	XMRP	4.9170	IN	YMRP	0.0000	IN	ZMRP	1.3900	IN	SCALE	0.0055	
PARAMETRIC VALUES																																															
BSTPOW	100.000	ORBPOW	100.000																																												
DELTA X	0.521	ALPHA I	5.000																																												
MACH	5.010	ELVBST	0.000																																												
ELVORB	0.000	BETA	0.000																																												
REFERENCE INFORMATION																																															
REFS	23.6890	SQ IN																																													
REFL	4.1930	IN																																													
REFB	6.5000	IN																																													
XMRP	4.9170	IN																																													
YMRP	0.0000	IN																																													
ZMRP	1.3900	IN																																													
SCALE	0.0055																																														

REFERENCE FILE

# AEDC VA 1163 MDAC BOOSTER AND ORBITER TEST DATA AT MACH NUMBER 5

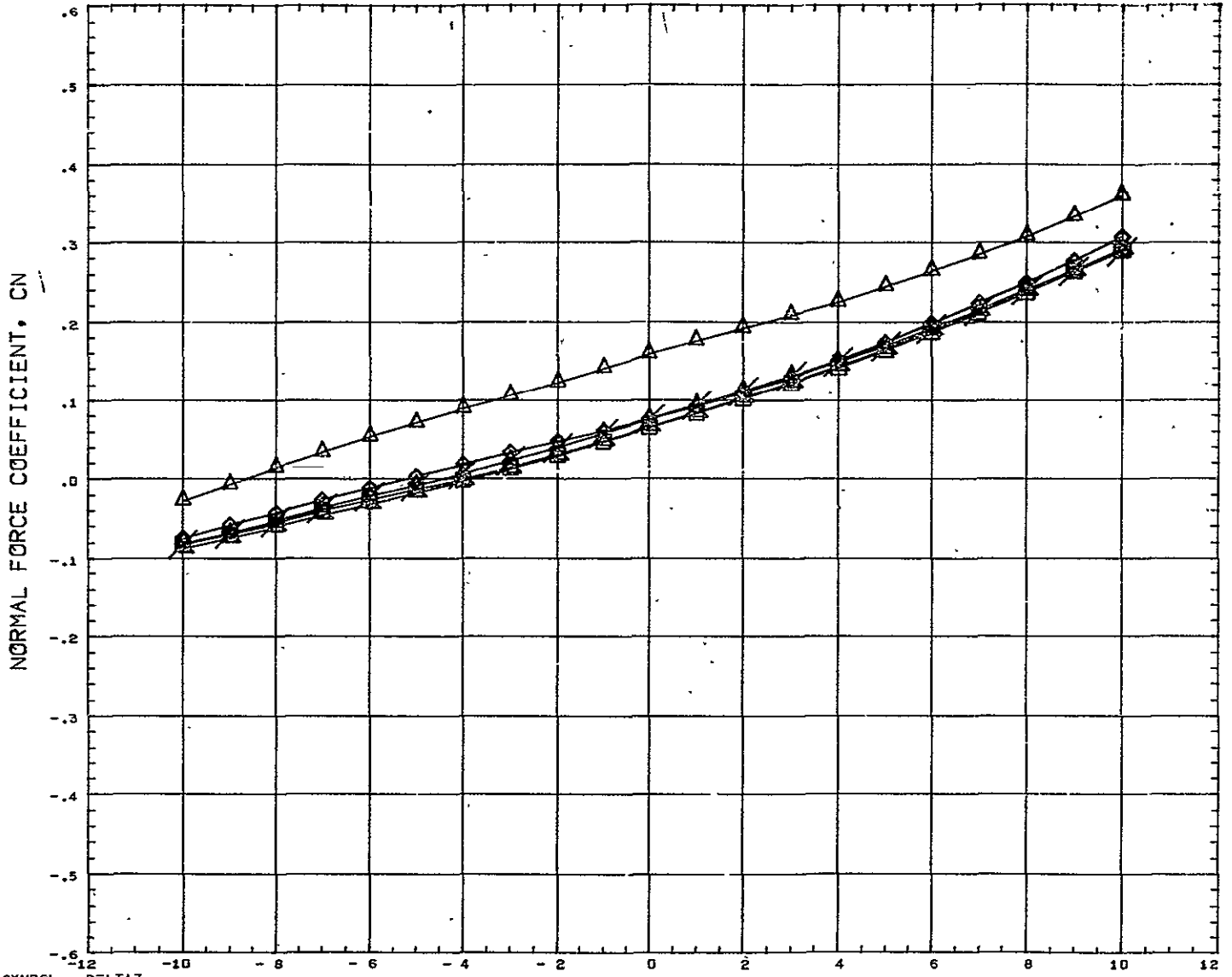

SYMBOL △ □ ◇ ○ ⊙	DELTA Z 0.151 0.182 0.228 0.352 10.000	PARAMETRIC VALUES BSTPOW 100.000 ORBPOW 100.000 DELTAX 0.521 ALPHAI 5.000 MACH 5.010 ELVBST 0.000 ELVORB 0.000 BETA 0.700	REFERENCE INFORMATION REFS 23.6890 SQ IN REFL 4.1930 IN REFB 6.5000 IN XMRP 4.5170 IN YMRP 0.0000 IN ZMRP 1.3900 IN SCALE 0.0055
---------------------------------	---	---	---

REFERENCE FILE

AEDC VA 1163 MDAC BOOSTER AND ORBITER TEST DATA AT MACH NUMBER 5

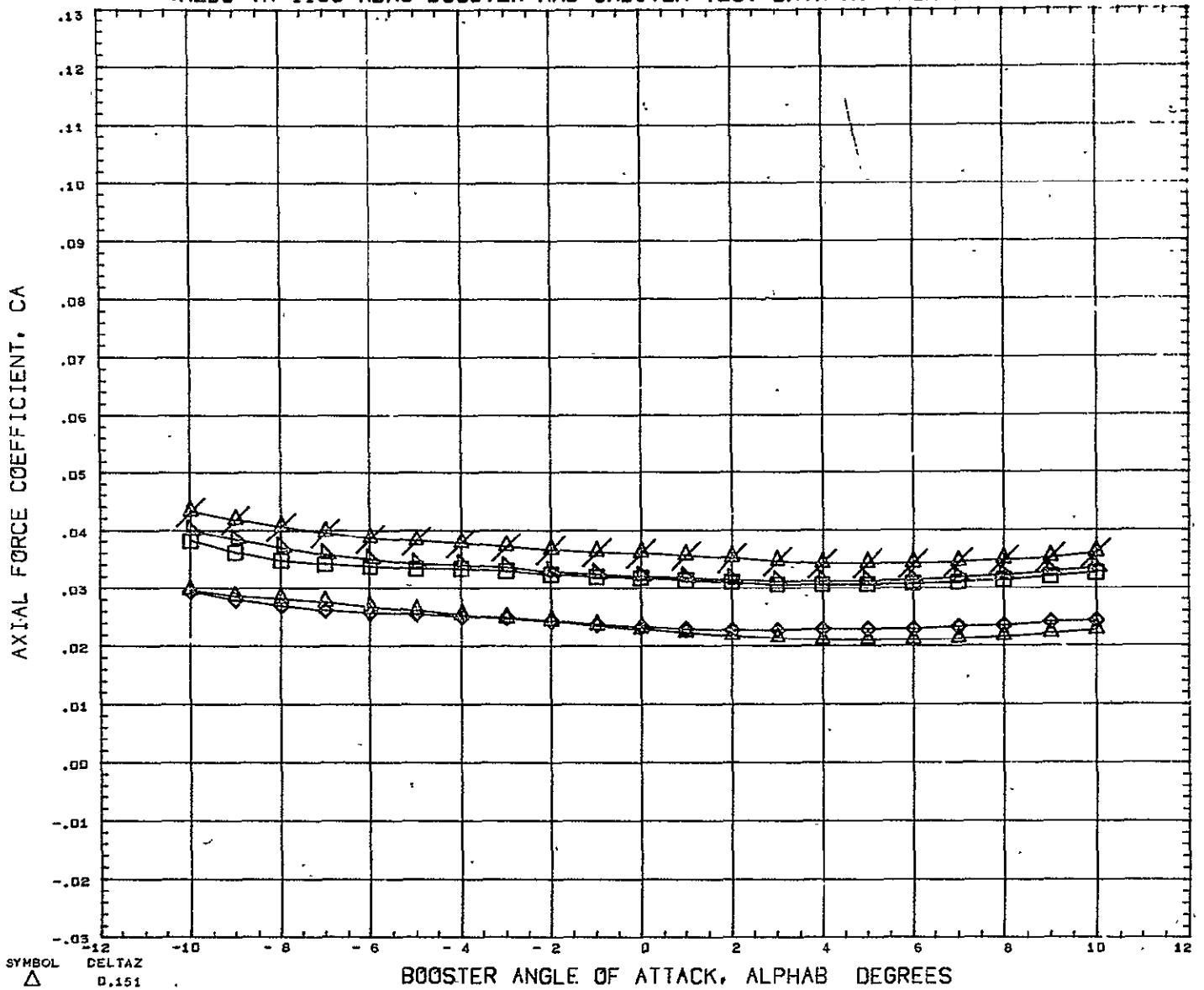

SYMBOL	DELTA Z	PARAMETRIC VALUES				REFERENCE INFORMATION		
△	0.151	BSTPOW	100.000	ORBPOW	100.000	REFS	23.6890	SQ IN
◇	0.182	DELTA X	0.521	ALPHA I	5.000	REFL	4.1930	IN
□	0.228	MACH	5.010	ELVBST	0.000	REFB	6.5000	IN
×	0.352	ELVORB	0.000	BETA	0.000	XMRP	4.9170	IN
	10.000					YMRP	0.0000	IN
						ZMRP	1.3900	IN
						SCALE	0.0055	

REFERENCE FILE

# AEDC VA 1163 MDAC BOOSTER AND ORBITER TEST DATA AT MACH NUMBER 5

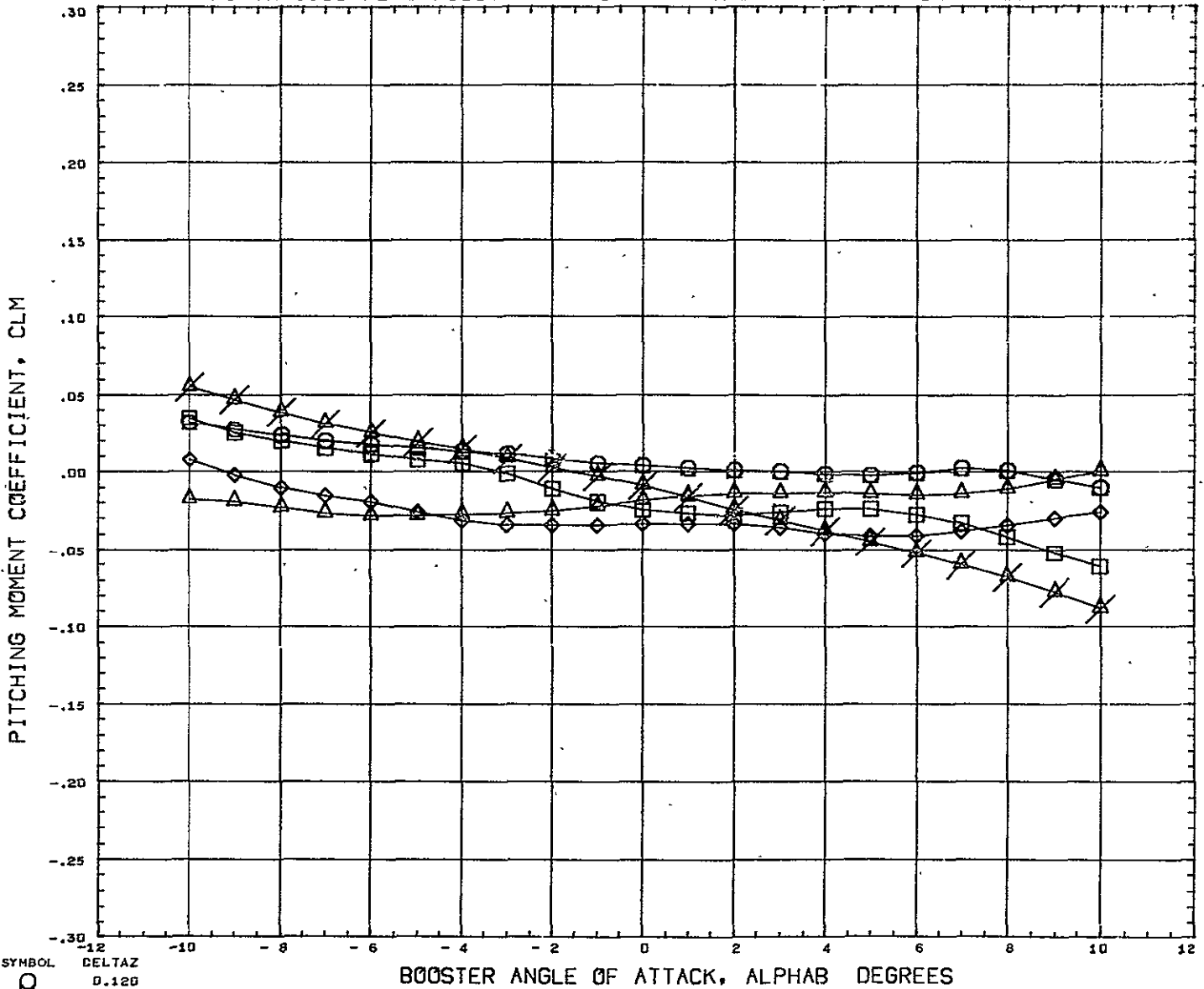

SYMBOL ○ △ ◇ □ ×	DELTAZ 0.120 0.151 0.182 0.228 10.000	PARAMETRIC VALUES BSTPOW 0.000 ORBPOW 100.000 DELTAX - 0.391 ALPHAI 0.000 MACH 5.010 ELVBST 0.000 ELVORB 0.000 BETA 0.000	REFERENCE INFORMATION REFS 23.6890 SQ IN REFL 4.1930 IN REFB 6.5000 IN XHRP 4.9170 IN YHRP 0.0000 IN ZHRP 1.3900 IN SCALE 0.0055
---------------------------------	--	---	---

REFERENCE FILE



# AEDC VA 1163 MDAC BOOSTER AND ORBITER TEST DATA AT MACH NUMBER 5

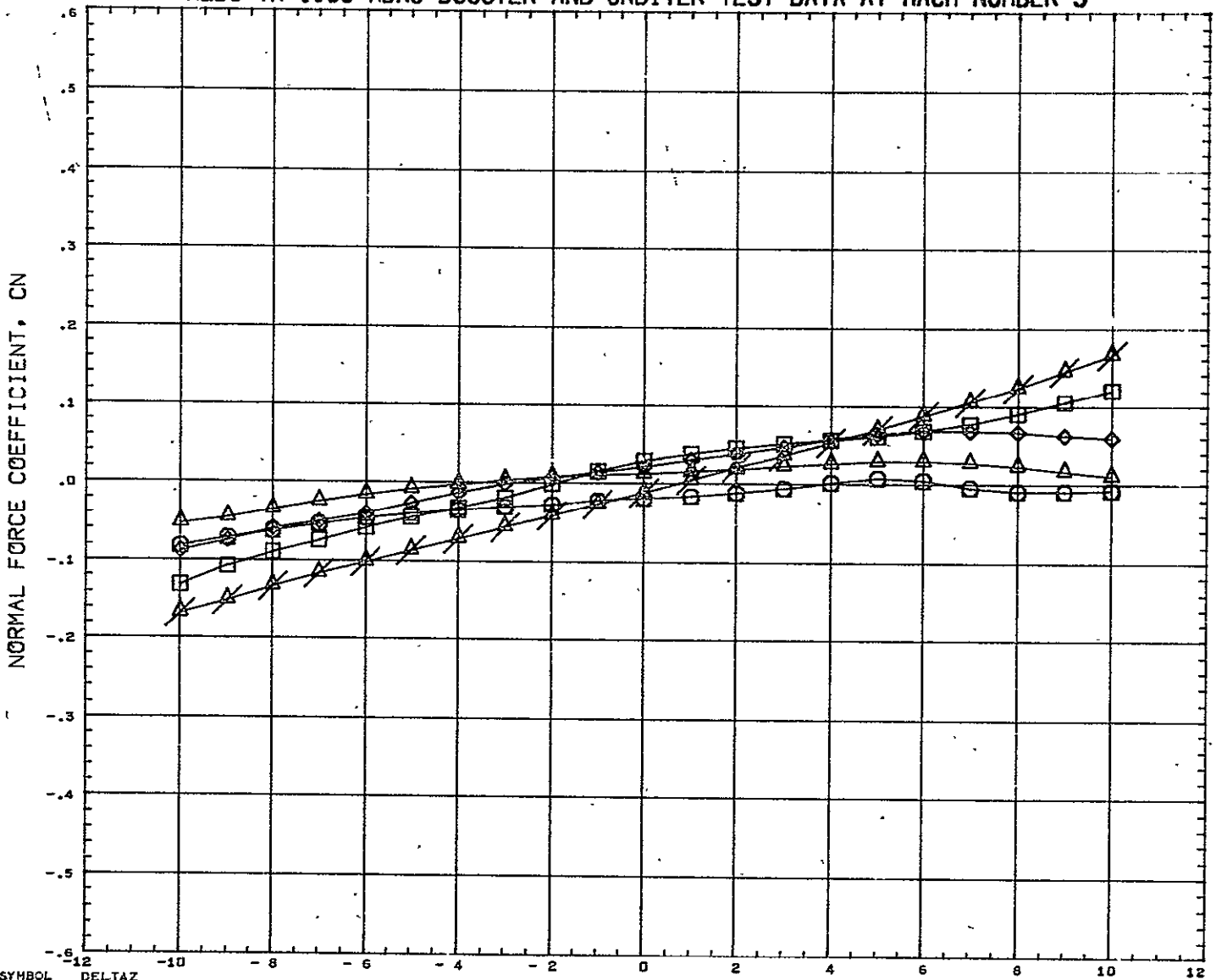

SYMBOL ○ □ ◇ △ ×	DELTAZ 0.120 0.151 0.182 0.228 10.000	PARAMETRIC VALUES BSTPOW 0.000 ORBPOW 100.000 DELTAX - 0.391 ALPHAI 0.000 MACH 5.010 ELVBST 0.000 ELVORB 0.000 BETA 9.000	REFERENCE INFORMATION REFS 23.6690 SQ IN REFL 4.1930 IN REFB 6.5000 IN XMRF 4.9170 IN YMRF 0.0000 IN ZMRF 1.3900 IN SCALE 0.0055
---------------------------------	--	---	---

REFERENCE FILE

# AEDC VA 1163 MDAC BOOSTER AND ORBITER TEST DATA AT MACH NUMBER 5

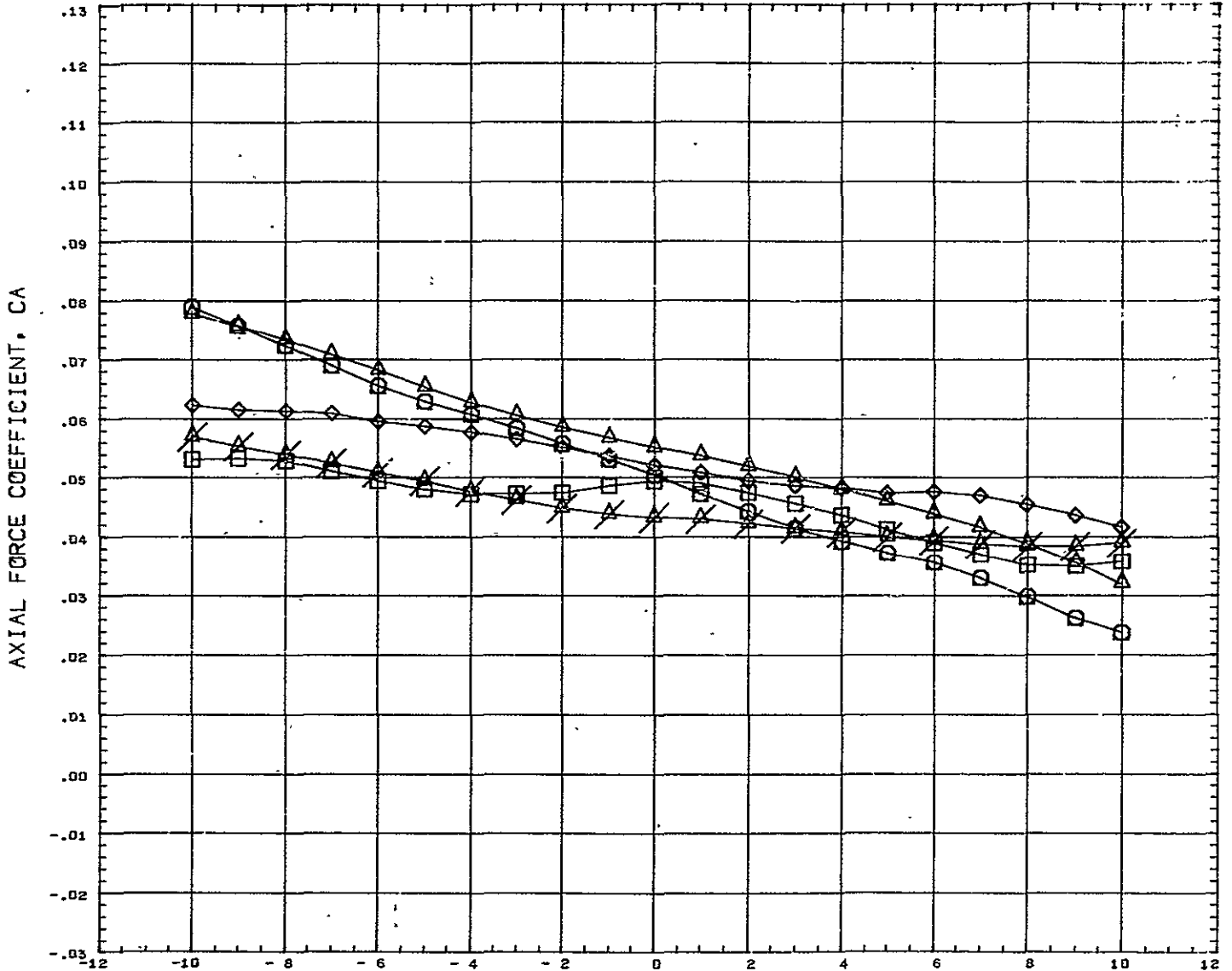

SYMBOL ○ △ □ ◇ ×	DELTA Z 0.120 0.151 0.182 0.228 10.000	PARAMETRIC VALUES BSTFOW 0.000 ORBPOW 100.000 DELTAX - 0.391 ALPHAI 0.000 MACH 5.010 ELVBST 0.000 ELVORB 0.000 BETA 0.000	REFERENCE INFORMATION REFS 23.6890 SQ IN REFL 4.1930 IN REFB 6.5000 IN XMRP 4.9170 IN YMRP 0.0000 IN ZMRP 1.3900 IN SCALE 0.0055
---------------------------------	---	---	---

REFERENCE FILE

# AEDC VA 1163 MDAC BOOSTER AND ORBITER TEST DATA AT MACH NUMBER 5

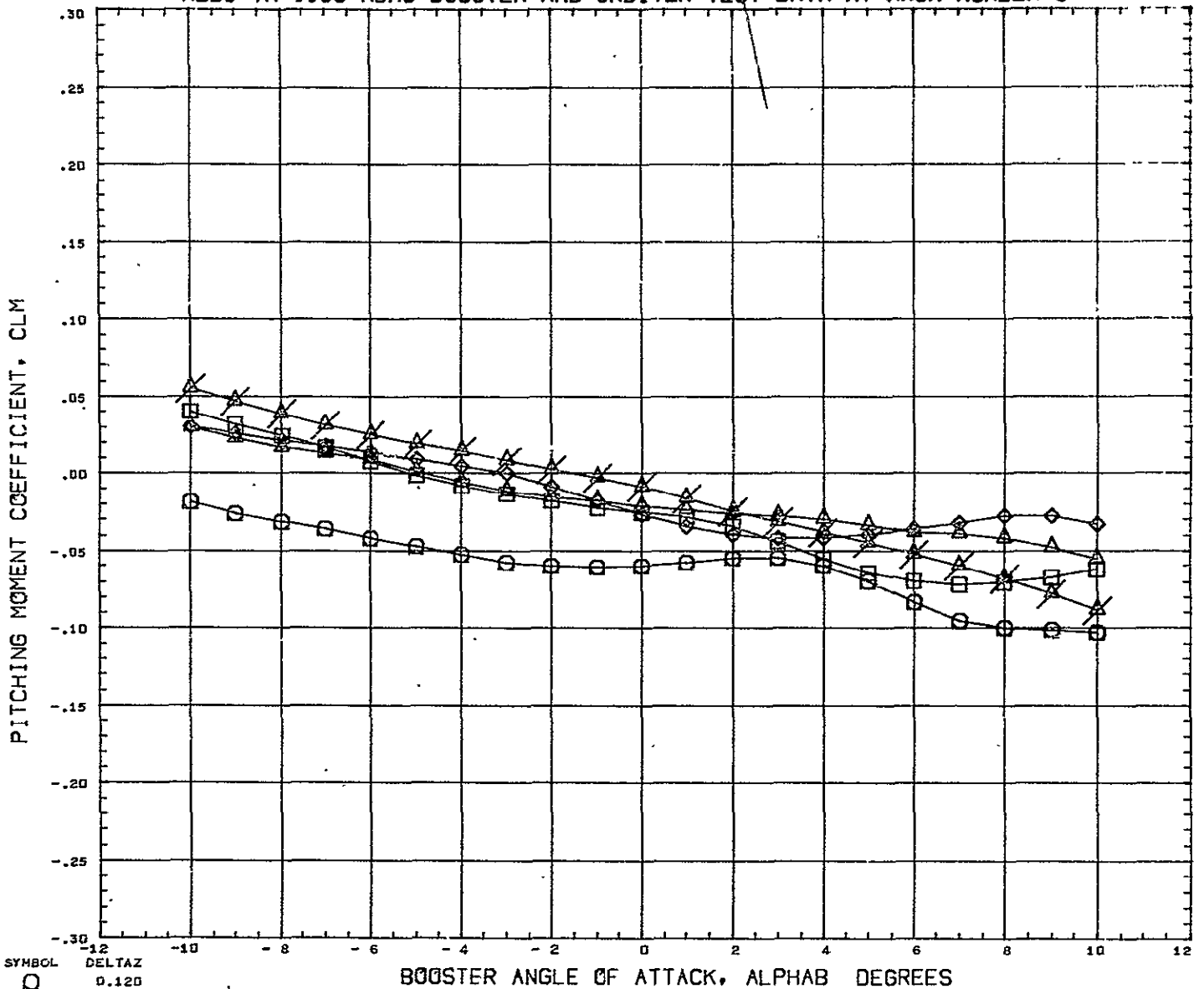

SYMBOL ○ △ ◇ □ ×	DELTAZ 0.120 0.151 0.182 0.228 10.000	<table border="0" style="width: 100%;"> <tr> <th colspan="4" style="text-align: center;">PARAMETRIC VALUES</th> </tr> <tr> <td>BSTPOW</td> <td>0.000</td> <td>ORBPOW</td> <td>100.000</td> </tr> <tr> <td>DELTAZ</td> <td>- 0.143</td> <td>ALPHA1</td> <td>0.000</td> </tr> <tr> <td>MACH</td> <td>5.010</td> <td>ELVBST</td> <td>0.000</td> </tr> <tr> <td>ELVORB</td> <td>0.000</td> <td>BETA</td> <td>0.000</td> </tr> </table>	PARAMETRIC VALUES				BSTPOW	0.000	ORBPOW	100.000	DELTAZ	- 0.143	ALPHA1	0.000	MACH	5.010	ELVBST	0.000	ELVORB	0.000	BETA	0.000	<table border="0" style="width: 100%;"> <tr> <th colspan="3" style="text-align: center;">REFERENCE INFORMATION</th> </tr> <tr> <td>REFS</td> <td>23.6890</td> <td>SQ IN</td> </tr> <tr> <td>REFL</td> <td>4.1930</td> <td>IN</td> </tr> <tr> <td>REFS</td> <td>6.5000</td> <td>IN</td> </tr> <tr> <td>XNRP</td> <td>4.9170</td> <td>IN</td> </tr> <tr> <td>YHRP</td> <td>0.0000</td> <td>IN</td> </tr> <tr> <td>ZHRP</td> <td>1.3900</td> <td>IN</td> </tr> <tr> <td>SCALE</td> <td>0.0055</td> <td></td> </tr> </table>	REFERENCE INFORMATION			REFS	23.6890	SQ IN	REFL	4.1930	IN	REFS	6.5000	IN	XNRP	4.9170	IN	YHRP	0.0000	IN	ZHRP	1.3900	IN	SCALE	0.0055	
PARAMETRIC VALUES																																															
BSTPOW	0.000	ORBPOW	100.000																																												
DELTAZ	- 0.143	ALPHA1	0.000																																												
MACH	5.010	ELVBST	0.000																																												
ELVORB	0.000	BETA	0.000																																												
REFERENCE INFORMATION																																															
REFS	23.6890	SQ IN																																													
REFL	4.1930	IN																																													
REFS	6.5000	IN																																													
XNRP	4.9170	IN																																													
YHRP	0.0000	IN																																													
ZHRP	1.3900	IN																																													
SCALE	0.0055																																														

REFERENCE FILE

# AEDC VA 1163 MDAC BOOSTER AND ORBITER TEST DATA AT MACH NUMBER 5

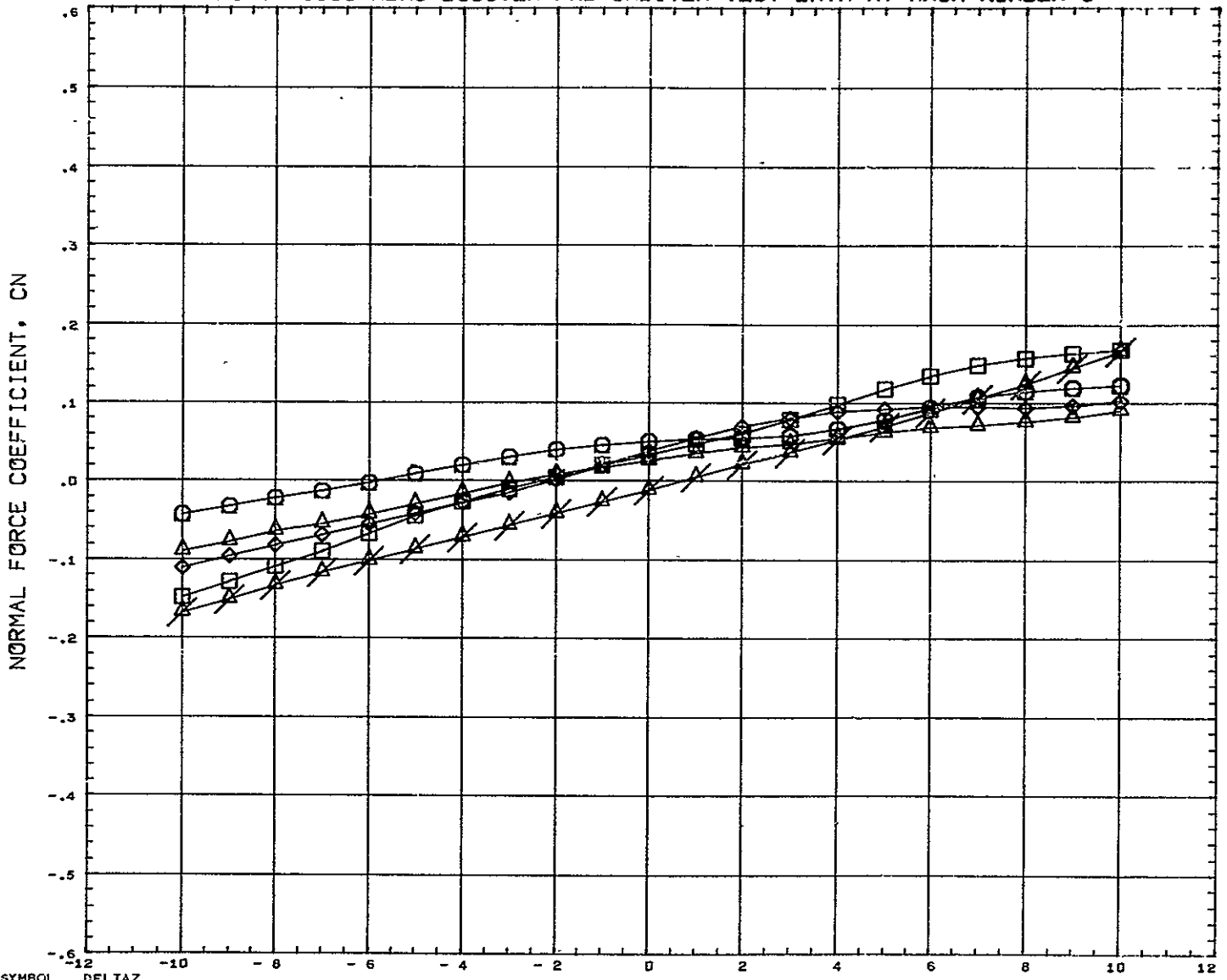

SYMBOL 	DELTAX 0.120 0.151 0.182 0.228 10.000	PARAMETRIC VALUES BSTFOW    0.000    ORBFW    100.000 DELTAX    - 0.143    ALPHAI    0.000 MACH       5.010    ELVBST    0.000 ELVORB    0.000    BETA      0.000	REFERENCE INFORMATION REFS       23.6890    SQ IN REFL       4.1930    IN REFB       6.5500    IN XMRP       4.9170    IN YMRP       0.0000    IN ZMRP       1.3900    IN SCALE      0.0055
------------	--	---	--

REFERENCE FILE

# AEDC VA 1163 MDAC BOOSTER AND ORBITER TEST DATA AT MACH NUMBER 5

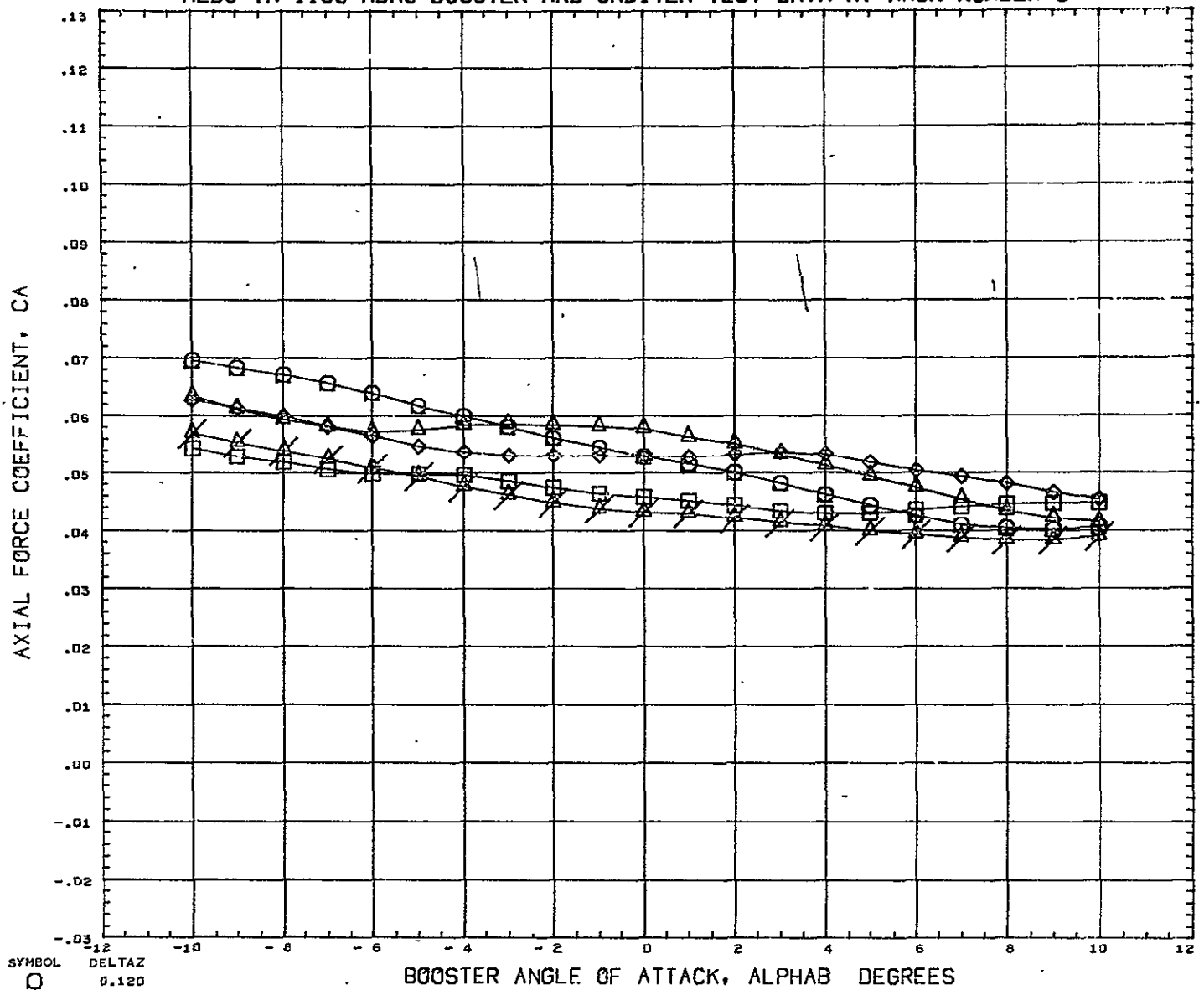

SYMBOL ○ ◇ □ △	DELTAX 0.120 0.151 0.182 0.228 10.000	PARAMETRIC VALUES BSTPOW 0.000 ORBFOW 100.000 DELTAX - 0.143 ALPHAI 0.000 MACH 5.010 ELVBST 0.000 ELVORB 0.000 BETA 0.000	REFERENCE INFORMATION REFS 23.6890 SQ IN REFL 4.1930 IN REFB 5.5800 IN XMRP 4.9170 IN YMRP 0.0000 IN ZMRP 1.3900 IN SCALE 0.0055
----------------------------	--	---	---

REFERENCE FILE

# AEDC VA 1163 MDAC BOOSTER AND ORBITER TEST DATA AT MACH NUMBER 5

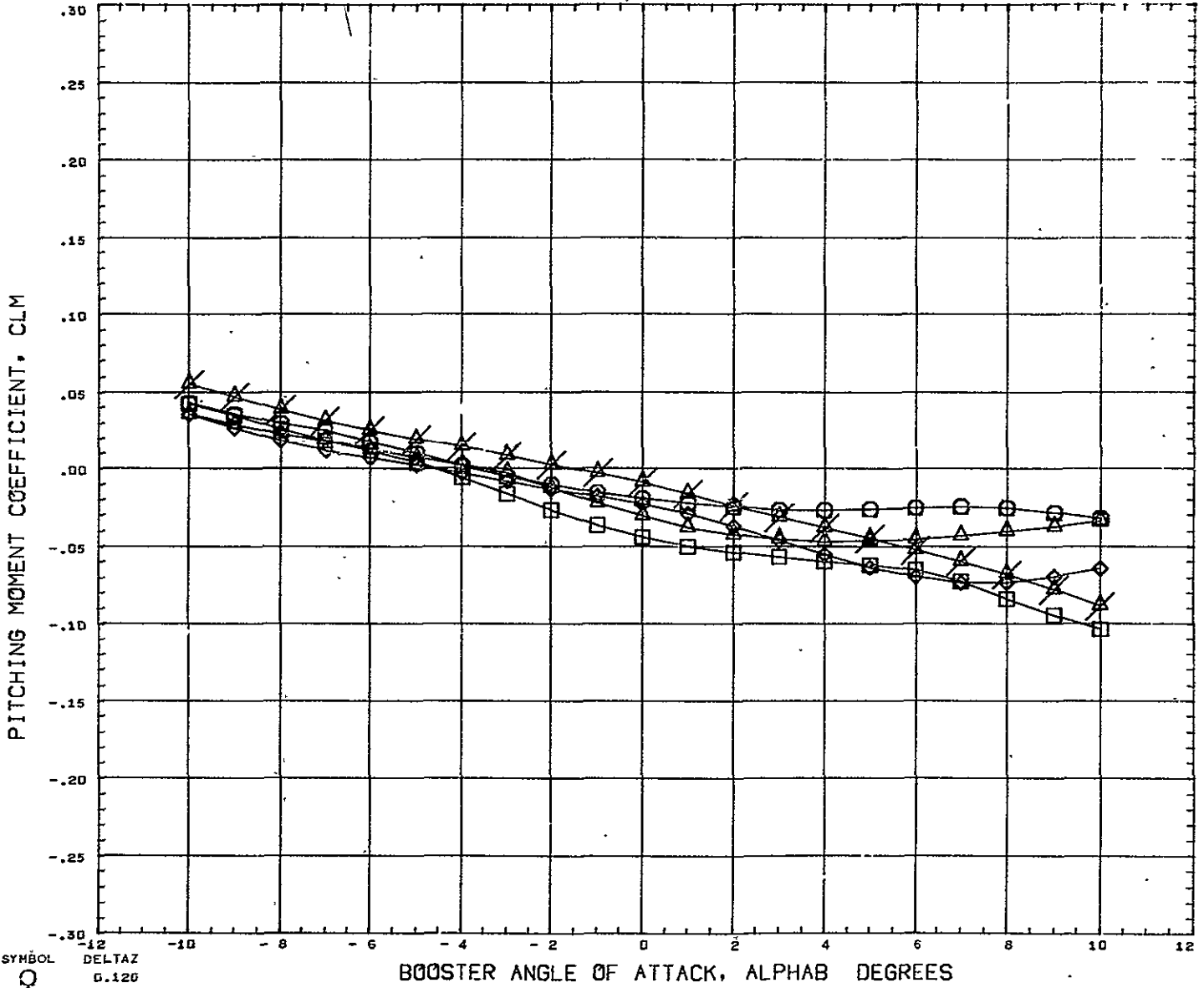

SYMBOL ○ ◇ □ △ ×	DELTAZ 0.120 0.151 0.182 0.228 10.000	PARAMETRIC VALUES BSTPOW 0.000 ORBPOW 100.000 DELTAX - 0.019 ALPHA1 0.000 MACH 5.010 ELVBST 0.000 ELVORB 0.000 BETA 0.000	REFERENCE INFORMATION REFS 23.6890 SQ IN REFL 4.1930 IN REFB 6.5000 IN XMRF 4.9170 IN YMRP 0.0000 IN ZMRP 1.3900 IN SCALE 0.0055
REFERENCE FILE			

# AEDC VA 1163 MDAC BOOSTER AND ORBITER TEST DATA AT MACH NUMBER 5

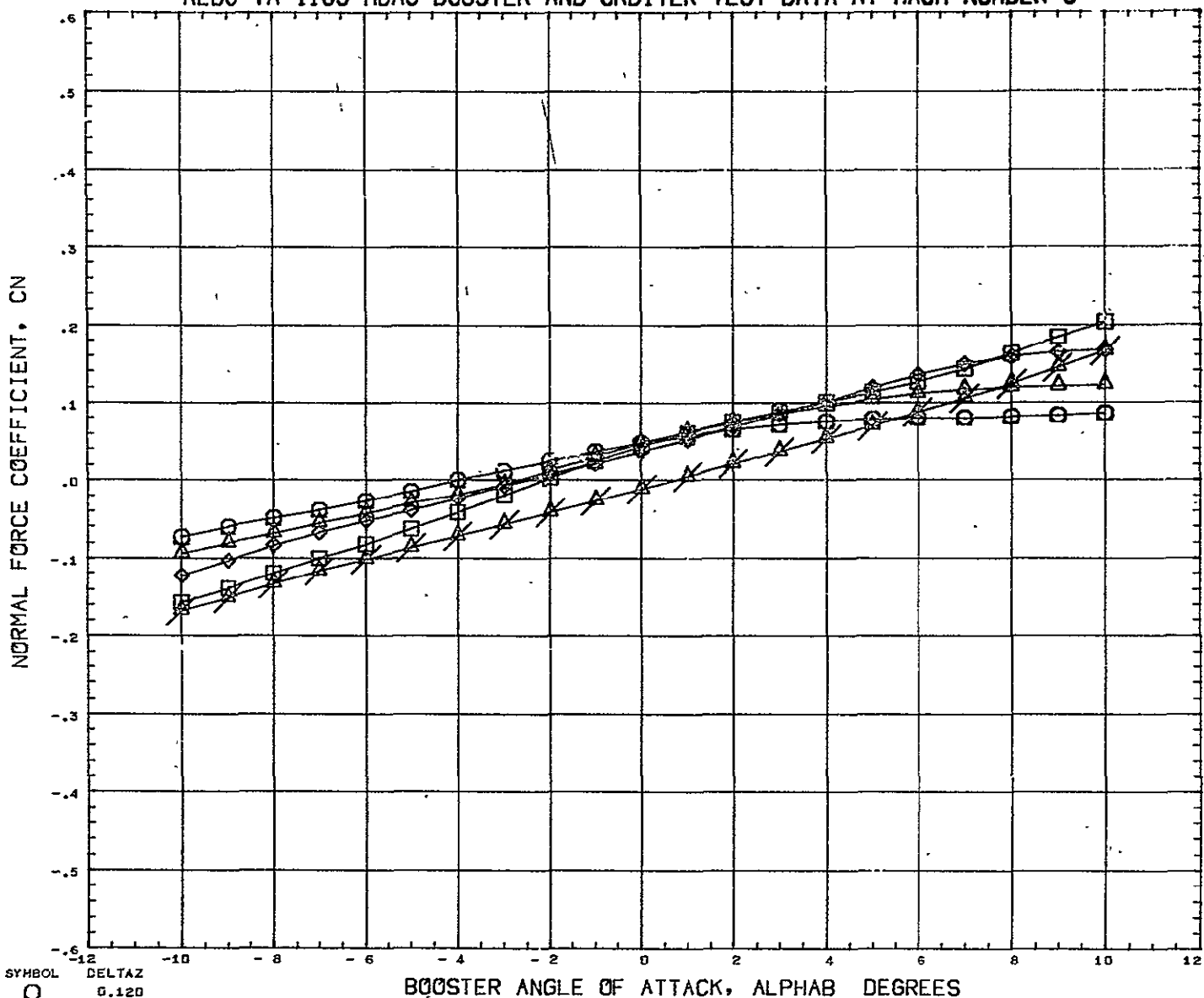

SYMBOL    DELTAZ  
 ○         0.120  
 △         0.151  
 ◇         0.182  
 □         0.228  
 ×         10.000

PARAMETRIC VALUES  
 BSTPOW    0.000    ORBPOW    100.000  
 DELTAX    - 0.019    ALPHAI    0.000  
 MACH       5.010    ELVBST    0.000  
 ELVORB    0.000    BETA       0.000

REFERENCE INFORMATION  
 REFS       23.6890    SQ IN  
 REFL       4.1930    IN  
 REFB       6.5000    IN  
 XMRP       4.9170    IN  
 YMRP       0.0000    IN  
 ZMRP       1.3900    IN  
 SCALE       0.0055

REFERENCE FILE

# AEDC VA 1163 MDAC BOOSTER AND ORBITER TEST DATA AT MACH NUMBER 5

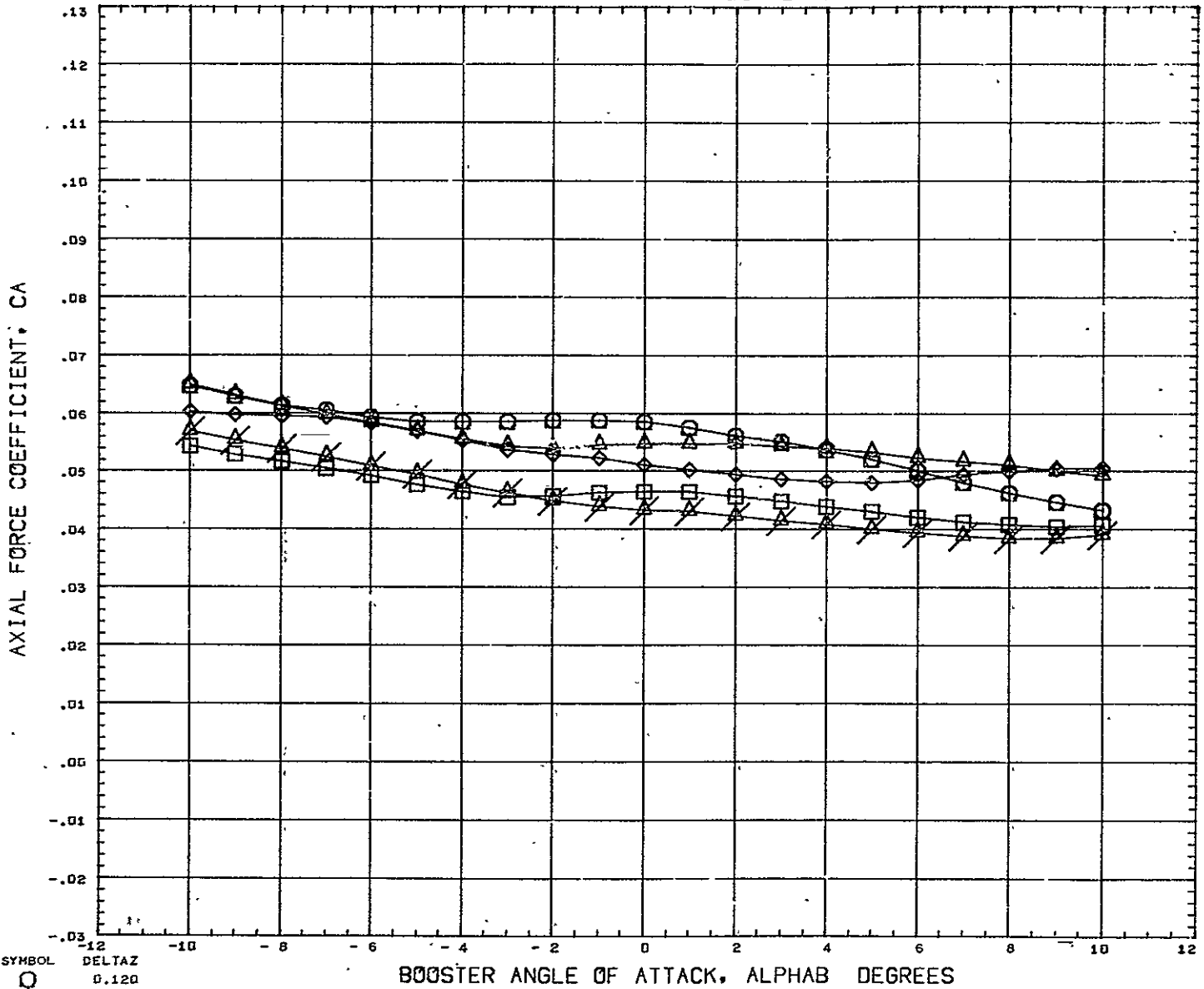

SYMBOL	DELTAZ	PARAMETRIC VALUES			
○	0.120	BSTPOW	0.000	ORBPOW	100.000
◇	0.151	DELTAZ	0.010	ALPHA1	0.000
□	0.182	MACH	5.010	ELVBST	0.000
△	0.228	ELVORB	0.000	BETA	0.000
×	10.000				

REFERENCE INFORMATION		
REFS	23.6890	SQ IN
REFL	4.1930	IN
REFB	6.5000	IN
XMRP	4.9170	IN
YMRF	0.0000	IN
ZMRP	1.3900	IN
SCALE	0.0055	

REFERENCE FILE



# AEDC VA 1163 MDAC BOOSTER AND ORBITER TEST DATA AT MACH NUMBER 5

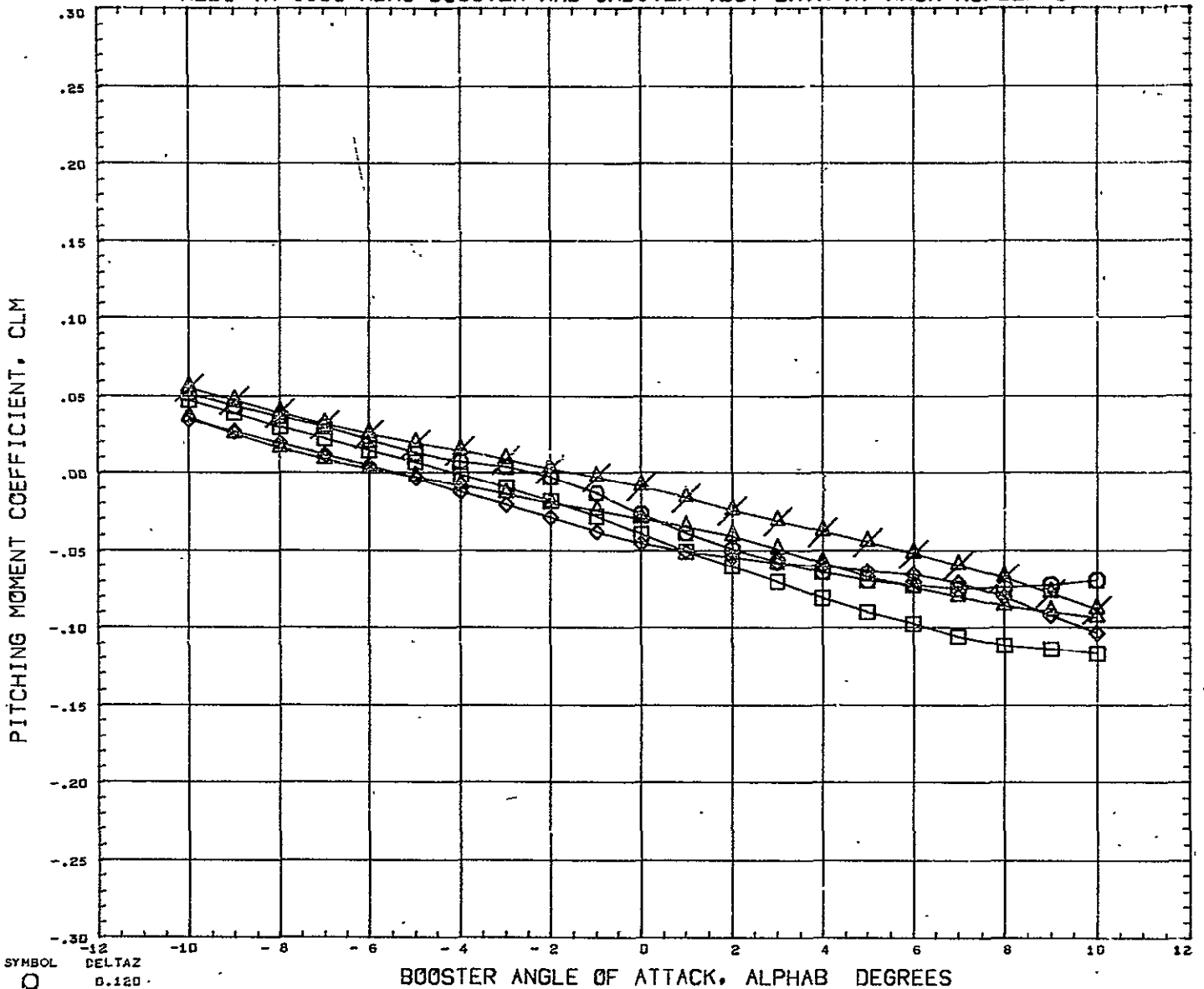

SYMBOL ○ △ ◇ □ ×	DELTAX 0.120 0.151 0.182 0.228 10.000	PARAMETRIC VALUES BSTPOW 0.000 ORBPOW 100.000 DELTAX 0.104 ALPHAI 0.000 MACH 5.010 ELVBST 0.000 ELVORB 0.000 BETA 0.000	REFERENCE INFORMATION REFS 23.6890 SQ IN REFL 4.1930 IN REFB 6.5000 IN XMRP 4.9170 IN YMRP 0.0000 IN ZMRP 1.3900 IN SCALE 0.0055
REFERENCE FILE			



# AEDC VA 1163 MDAC BOOSTER AND ORBITER TEST DATA AT MACH NUMBER 5

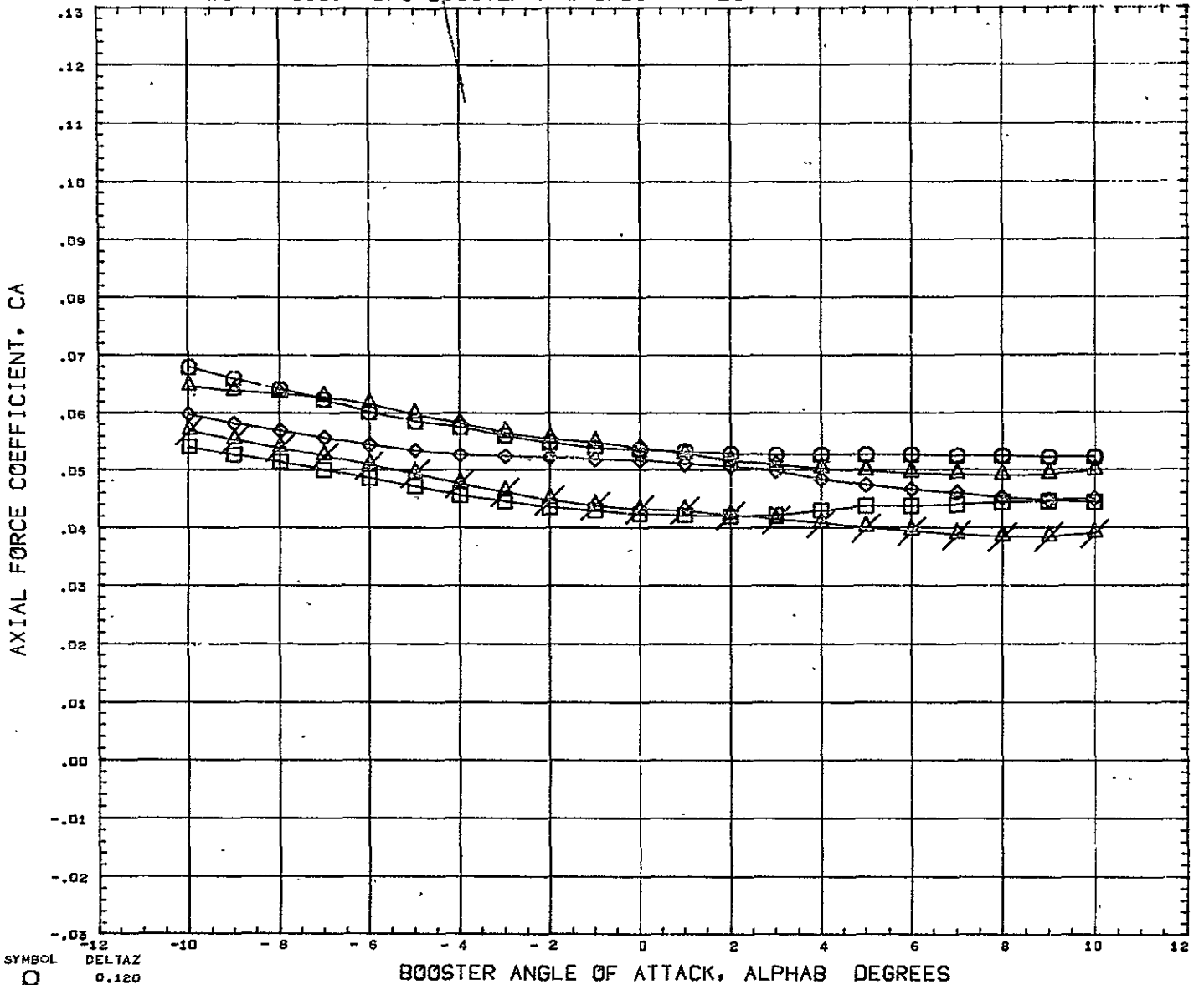

SYMBOL ○ ◇ □ △ ×	DELTA Z 0.120 0.151 0.102 0.228 10.000	PARAMETRIC VALUES BSTPOW 0.000 ORBPOW 100.000 DELTAX 0.104 ALPHA1 0.000 MACH 5.010 ELVBST 0.000 ELVORD 0.000 BETA 0.000	REFERENCE INFORMATION REFS 23.6890 SQ IN REFL 4.1930 IN REFB 6.5000 IN XMRP 4.9170 IN YMRP 0.0000 IN ZMRP 1.3900 IN SCALE 0.0055
---------------------------------	---	---	---

REFERENCE FILE

# AEDC VA 1163 MDAC BOOSTER AND ORBITER TEST DATA AT MACH NUMBER 5

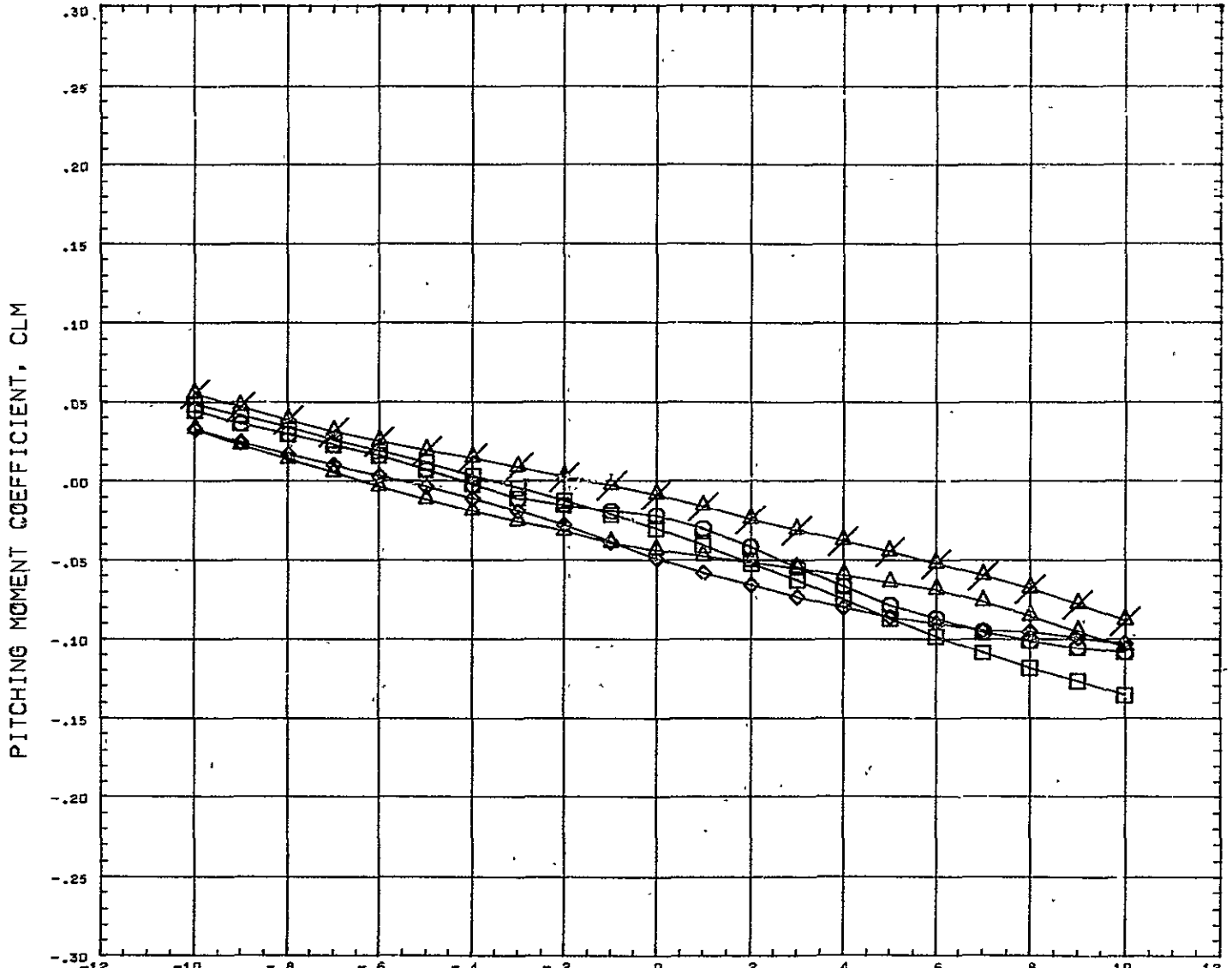

SYMBOL ○ ◇ □ △	DELTA Z 0.120 0.151 0.182 0.228 10.000	<table border="0" style="width: 100%;"> <tr> <th colspan="4" style="text-align: left;">PARAMETRIC VALUES</th> </tr> <tr> <td>BSTFOW</td> <td>0.000</td> <td>ORBPOW</td> <td>100.000</td> </tr> <tr> <td>DELTA X</td> <td>0.166</td> <td>ALPHA I</td> <td>0.000</td> </tr> <tr> <td>MACH</td> <td>5.010</td> <td>ELVBST</td> <td>0.000</td> </tr> <tr> <td>ELVORB</td> <td>0.000</td> <td>BETA</td> <td>0.000</td> </tr> </table>	PARAMETRIC VALUES				BSTFOW	0.000	ORBPOW	100.000	DELTA X	0.166	ALPHA I	0.000	MACH	5.010	ELVBST	0.000	ELVORB	0.000	BETA	0.000	<table border="0" style="width: 100%;"> <tr> <th colspan="3" style="text-align: left;">REFERENCE INFORMATION</th> </tr> <tr> <td>REFS</td> <td>23.6890</td> <td>SQ. IN</td> </tr> <tr> <td>REFL</td> <td>4.1930</td> <td>IN</td> </tr> <tr> <td>REFB</td> <td>6.5000</td> <td>IN</td> </tr> <tr> <td>XMRP</td> <td>4.9170</td> <td>IN</td> </tr> <tr> <td>YMRP</td> <td>0.0000</td> <td>IN</td> </tr> <tr> <td>ZMRP</td> <td>1.3900</td> <td>IN</td> </tr> <tr> <td>SCALE</td> <td>0.0055</td> <td></td> </tr> </table>	REFERENCE INFORMATION			REFS	23.6890	SQ. IN	REFL	4.1930	IN	REFB	6.5000	IN	XMRP	4.9170	IN	YMRP	0.0000	IN	ZMRP	1.3900	IN	SCALE	0.0055	
PARAMETRIC VALUES																																															
BSTFOW	0.000	ORBPOW	100.000																																												
DELTA X	0.166	ALPHA I	0.000																																												
MACH	5.010	ELVBST	0.000																																												
ELVORB	0.000	BETA	0.000																																												
REFERENCE INFORMATION																																															
REFS	23.6890	SQ. IN																																													
REFL	4.1930	IN																																													
REFB	6.5000	IN																																													
XMRP	4.9170	IN																																													
YMRP	0.0000	IN																																													
ZMRP	1.3900	IN																																													
SCALE	0.0055																																														

REFERENCE FILE

# AEDC VA 1163 MDAC BOOSTER AND ORBITER TEST DATA AT MACH NUMBER 5

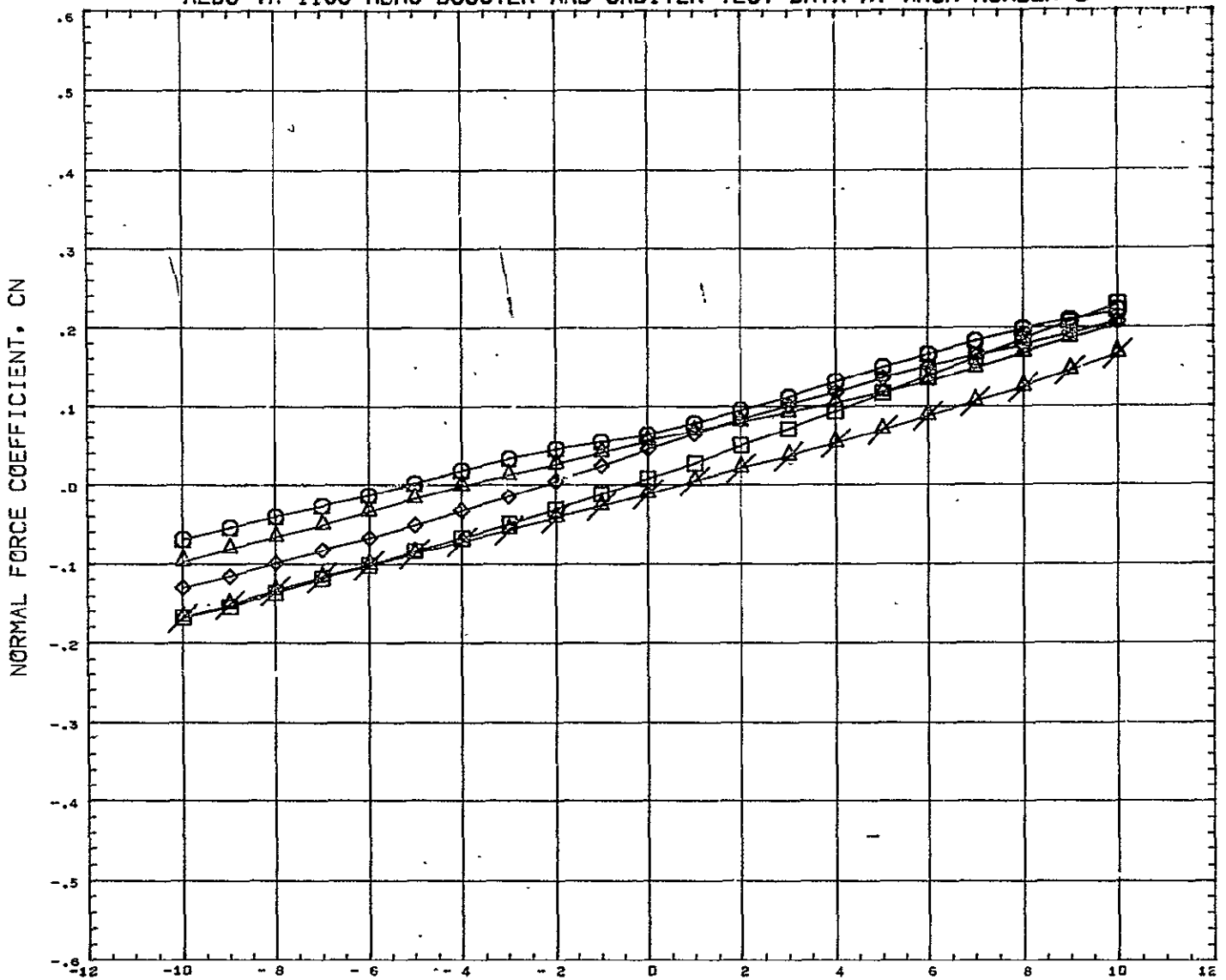

SYMBOL ○ ◇ □ △ ×	DELTAZ 0.120 0.151 0.182 0.228 10.000	PARAMETRIC VALUES BSTFOW 0.000 CRBPOW 100.000 DELTAX 0.166 ALPHAI 0.000 MACH 5.010 ELVBST 0.000 ELVORB 0.000 BETA 0.000	REFERENCE INFORMATION REFS 23.6890 SQ IN REFL 4.1930 IN REFB 6.5000 IN XMRP 4.9170 IN YMRP 0.0000 IN ZMRP 1.3900 IN SCALE 0.0055
---------------------------------	--	---	---

REFERENCE FILE

# AEDC VA 1163 MDAC BOOSTER AND ORBITER TEST DATA AT MACH NUMBER 5

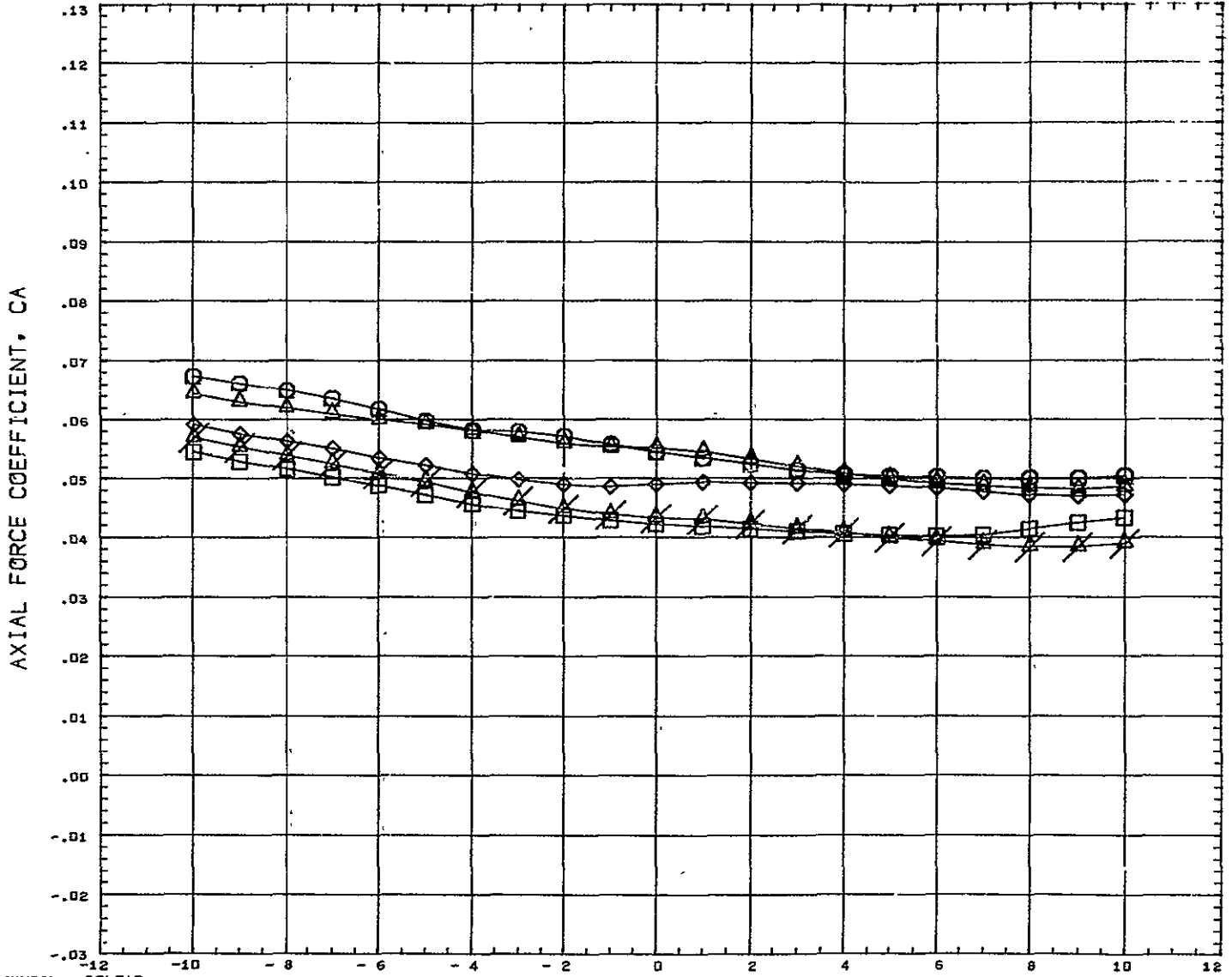

SYMBOL ○ △ ◇ □ ☆	DELTAZ 0.120 0.151 0.182 0.228 10.000	<table border="0" style="width: 100%;"> <tr> <th colspan="4" style="text-align: center;">PARAMETRIC VALUES</th> </tr> <tr> <td>BSTPOW</td><td>0.000</td><td>ORBPOW</td><td>100.000</td> </tr> <tr> <td>DELTAZ</td><td>0.166</td><td>ALPHA1</td><td>0.000</td> </tr> <tr> <td>MACH</td><td>5.010</td><td>ELVBS1</td><td>0.000</td> </tr> <tr> <td>ELVORB</td><td>0.000</td><td>BETA</td><td>0.050</td> </tr> </table>	PARAMETRIC VALUES				BSTPOW	0.000	ORBPOW	100.000	DELTAZ	0.166	ALPHA1	0.000	MACH	5.010	ELVBS1	0.000	ELVORB	0.000	BETA	0.050	<table border="0" style="width: 100%;"> <tr> <th colspan="3" style="text-align: center;">REFERENCE INFORMATION</th> </tr> <tr> <td>REFS</td><td>23.6890</td><td>SQ IN</td> </tr> <tr> <td>REFL</td><td>4.1950</td><td>IN</td> </tr> <tr> <td>REFB</td><td>6.5000</td><td>IN</td> </tr> <tr> <td>XMRP</td><td>4.9170</td><td>IN</td> </tr> <tr> <td>YMRP</td><td>0.0000</td><td>IN</td> </tr> <tr> <td>ZMRP</td><td>1.3900</td><td>IN</td> </tr> <tr> <td>SCALE</td><td>0.0055</td><td></td> </tr> </table>	REFERENCE INFORMATION			REFS	23.6890	SQ IN	REFL	4.1950	IN	REFB	6.5000	IN	XMRP	4.9170	IN	YMRP	0.0000	IN	ZMRP	1.3900	IN	SCALE	0.0055	
PARAMETRIC VALUES																																															
BSTPOW	0.000	ORBPOW	100.000																																												
DELTAZ	0.166	ALPHA1	0.000																																												
MACH	5.010	ELVBS1	0.000																																												
ELVORB	0.000	BETA	0.050																																												
REFERENCE INFORMATION																																															
REFS	23.6890	SQ IN																																													
REFL	4.1950	IN																																													
REFB	6.5000	IN																																													
XMRP	4.9170	IN																																													
YMRP	0.0000	IN																																													
ZMRP	1.3900	IN																																													
SCALE	0.0055																																														

REFERENCE FILE

# AEDC VA 1163 MDAC BOOSTER AND ORBITER TEST DATA AT MACH NUMBER 5

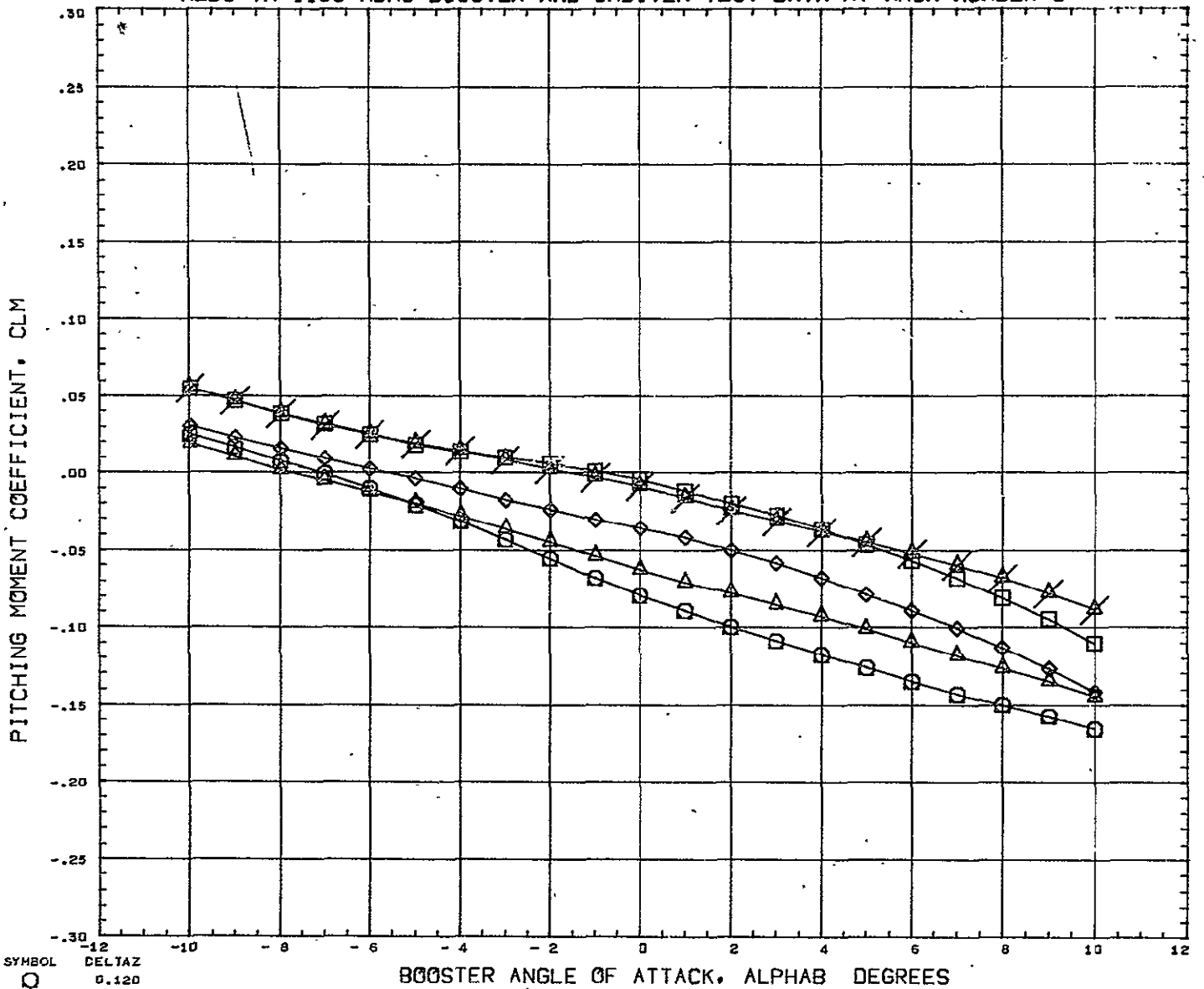

SYMBOL ○ ◇ □ △ ×	DELTA Z 0.120 0.151 0.182 0.228 10.000	PARAMETRIC VALUES BSTPOW 0.000 ORBPOW 100.000 DELTAX 0.351 ALPHAI 0.000 MACH 5.010 ELVBST 0.000 ELVORB 0.000 BETA 0.000	REFERENCE INFORMATION REFS 23.6890 SQ IN REFL 4.1930 IN REFB 6.5000 IN XMRP 4.9170 IN YMRP 0.0000 IN ZMRP 1.3900 IN SCALE 0.0055
---------------------------------	---	---	---

REFERENCE FILE

# AEDC VA 1163 MDAC BOOSTER AND ORBITER TEST DATA AT MACH NUMBER 5

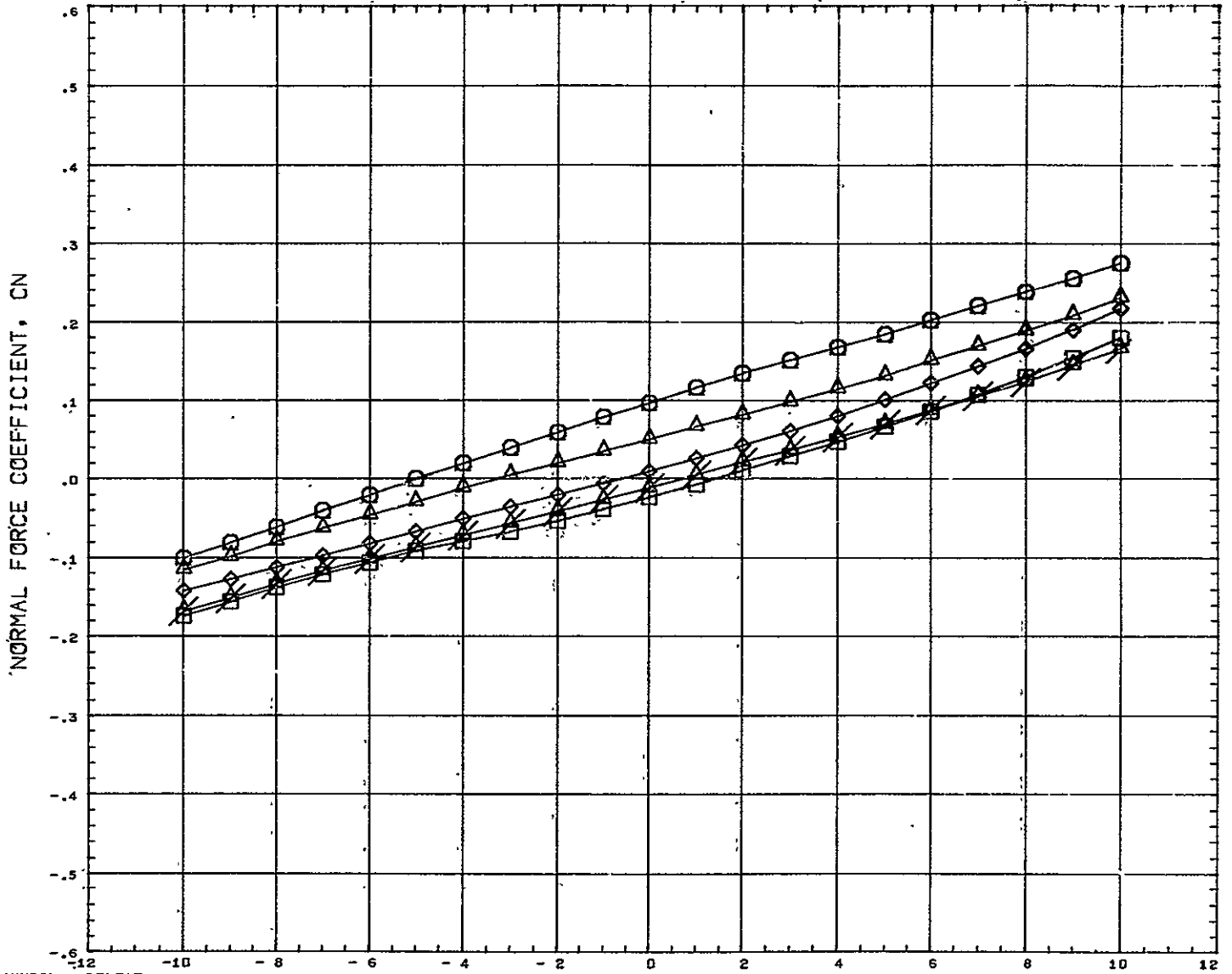

SYMBOL 	DELTAX 0.120 0.151 0.182 0.228 10.000	<b>PARAMETRIC VALUES</b> BSTPOW    0.000    ORBPOW    100.000 DELTAX    0.351    ALPHA1    0.000 MACH      5.010    ELVBST    0.000 ELVORB    0.000    BETA      0.000	<b>REFERENCE INFORMATION</b> REFS      23.6890    SQ IN REFL      4.1930    IN REFB      6.5000    IN XMRF      4.9170    IN YMRF      0.0000    IN ZMRF      1.3900    IN SCALE     0.0055
REFERENCE FILE			



# AEDC VA 1163 MDAC BOOSTER AND ORBITER TEST DATA AT MACH NUMBER 5

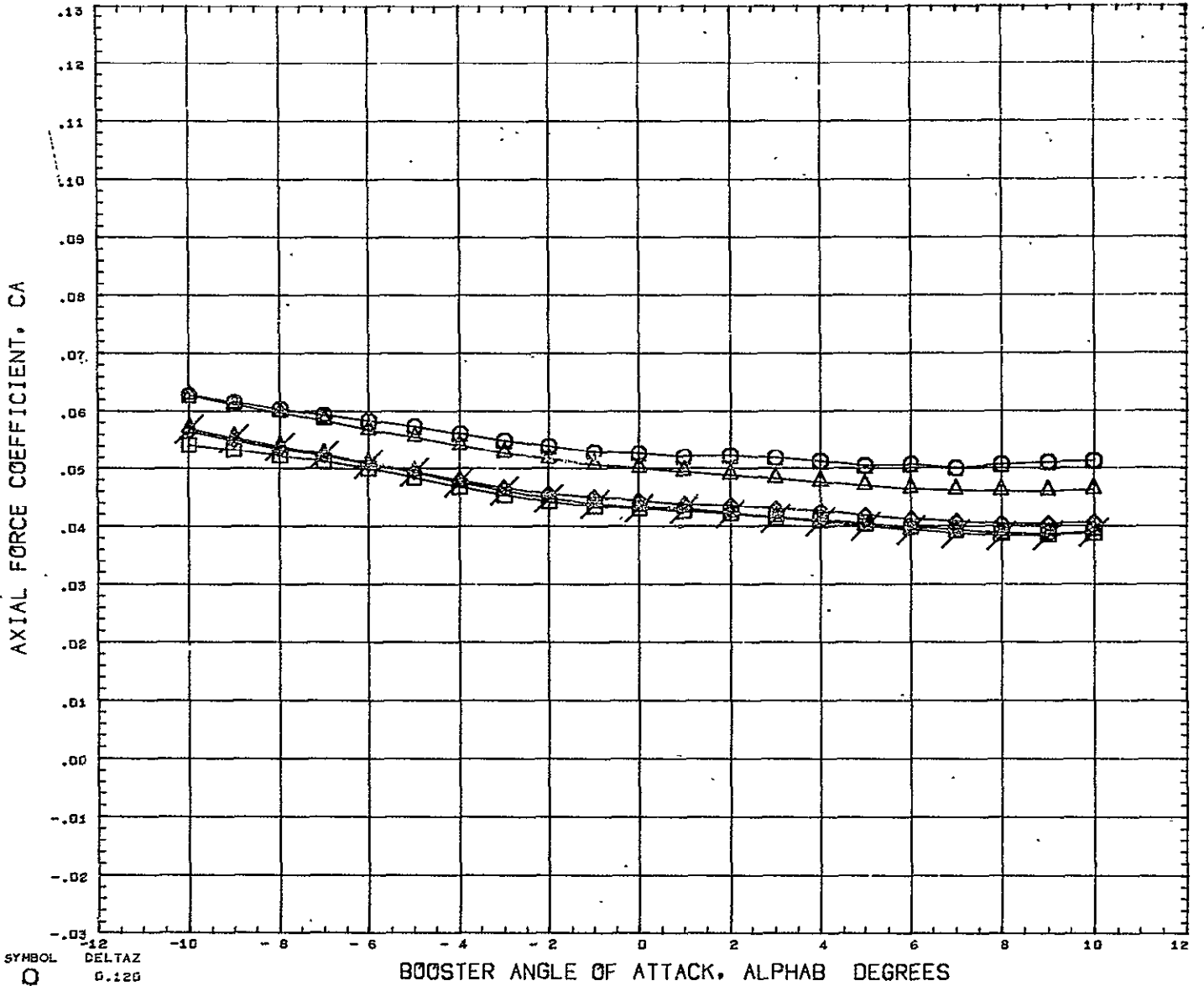

SYMBOL ○ □ △ ◇ ×	DELTAZ 0.120 0.151 0.182 0.228 10.000	PARAMETRIC VALUES BSTPOW 0.000 ORBPOW 100.000 DELTAX 0.351 ALPHAI 0.000 MACH 5.010 ELVBST 0.000 ELVORB 0.000 BETA 0.000	REFERENCE INFORMATION REFS 23.6090 SQ IN REFL 4.1930 IN REFB 6.5000 IN XMRP 4.9170 IN YMRP 0.0000 IN ZMRP 1.3900 IN SCALE 0.0055
---------------------------------	--	---	---

REFERENCE FILE

# AEDC VA 1163 MDAC BOOSTER AND ORBITER TEST DATA AT MACH NUMBER 5

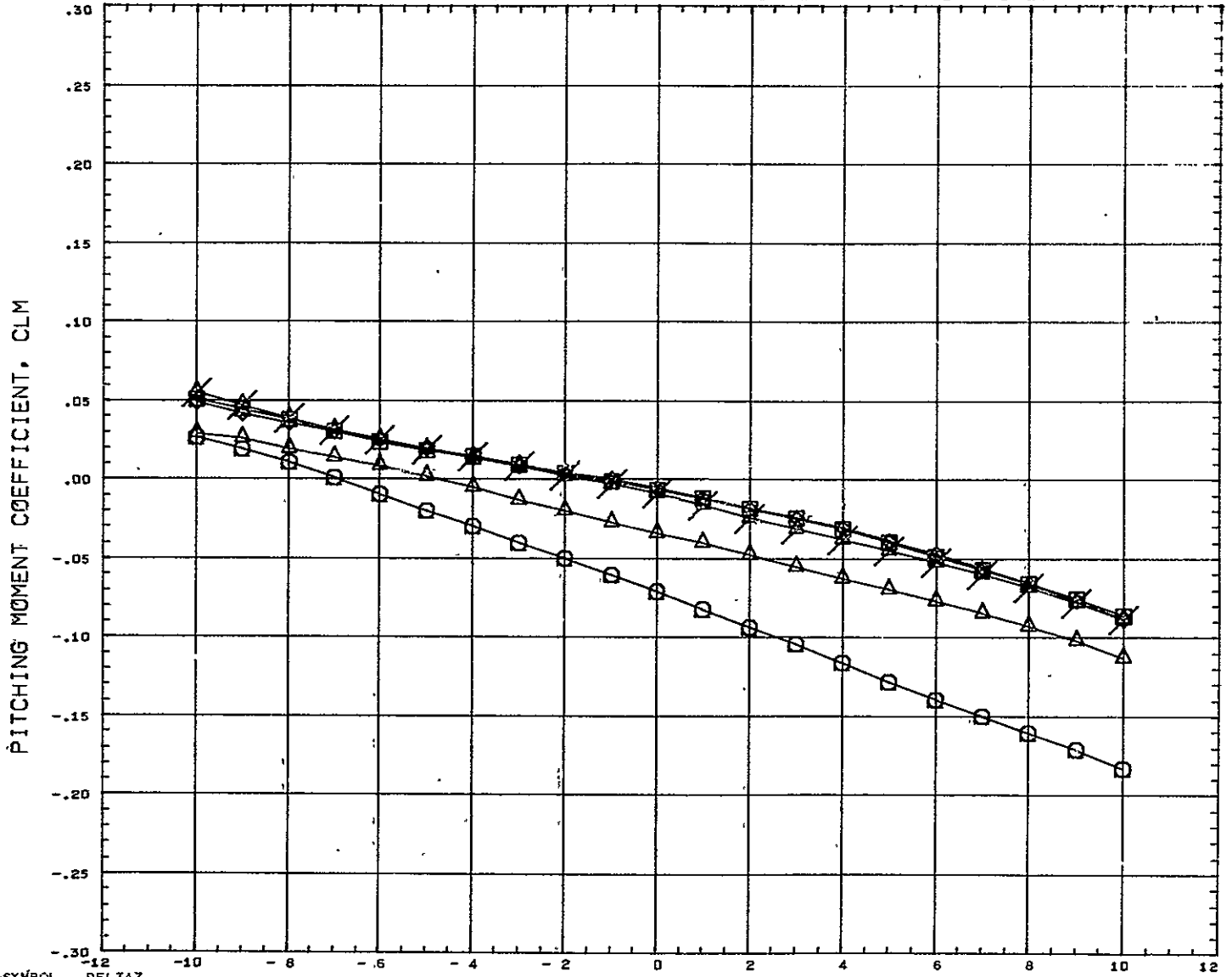

SYMBOL DELTA Z  
 ○ 0.120  
 △ 0.151  
 □ 0.182  
 ◇ 0.228  
 ✕ 10.000

**PARAMETRIC VALUES**

9STPOW	0.000	ORBPOW	100.000
DELTA X	0.522	ALPHA I	0.000
MACH	5.010	ELVBST	0.000
ELVORB	0.000	BETA	0.000

**REFERENCE INFORMATION**

REFS	23.6890	SQ IN
REFL	4.1930	IN
REFB	6.5000	IN
XMRP	4.9170	IN
YMRP	0.0000	IN
ZMRP	1.3900	IN
SCALE	0.0055	

REFERENCE FILE

# AEDC VA 1163 MDAC BOOSTER AND ORBITER TEST DATA AT MACH NUMBER 5

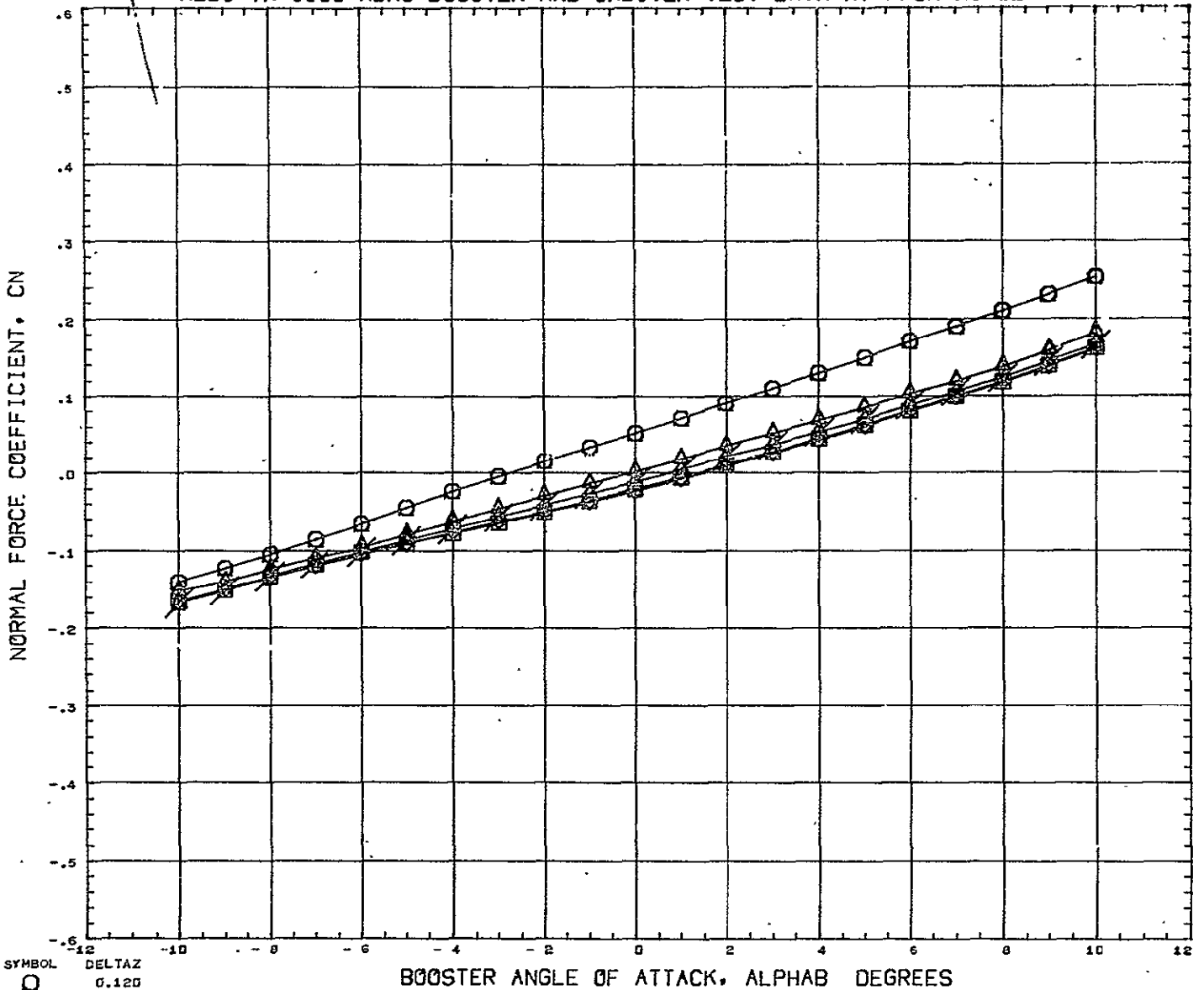

SYMBOL

- 
- 
- △
- ◇

DELTA Z

- 0.120
- 0.151
- 0.182
- 0.228
- 10.000

- BSTFOW
- DELTA X
- MACH
- ELVORB

PARAMETRIC VALUES

- 0.000
- 0.522
- 5.010
- 0.000
- 0.000
- 100.000
- 0.000
- 0.000

BOOSTER ANGLE OF ATTACK, ALPHAB DEGREES

REFERENCE INFORMATION

- |       |         |       |
|-------|---------|-------|
| REFS  | 23.6890 | SQ IN |
| REFL  | 4.1930  | IN    |
| REFB  | 6.5000  | IN    |
| XMRP  | 4.9170  | IN    |
| YMRP  | 0.0000  | IN    |
| ZMRP  | 1.3900  | IN    |
| SCALE | 0.0055  |       |

REFERENCE FILE

# AEDC VA 1163 MDAC BOOSTER AND ORBITER TEST DATA AT MACH NUMBER 5

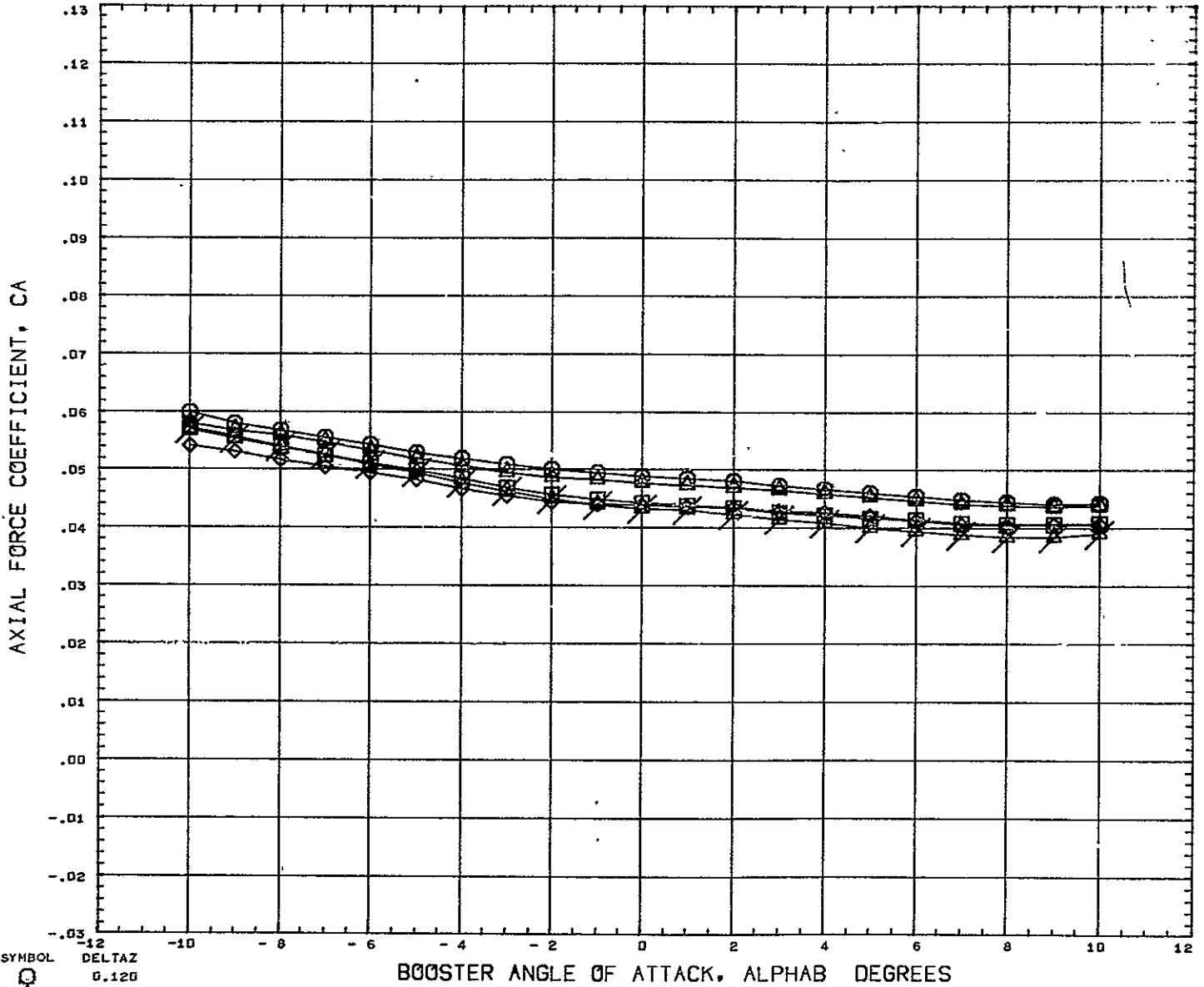

SYMBOL ○ △ □ ◇ ×	DELTA Z 0.120 0.151 0.182 0.228 10.000	<table border="0" style="width: 100%;"> <tr> <th colspan="4" style="text-align: left;">PARAMETRIC VALUES</th> </tr> <tr> <td>9STFOW</td> <td>0.000</td> <td>ORBPOW</td> <td>100.000</td> </tr> <tr> <td>DELTA X</td> <td>0.522</td> <td>ALPHA I</td> <td>0.000</td> </tr> <tr> <td>MACH</td> <td>5.010</td> <td>ELVBST</td> <td>0.000</td> </tr> <tr> <td>ELVORS</td> <td>0.000</td> <td>BETA</td> <td>0.000</td> </tr> </table>	PARAMETRIC VALUES				9STFOW	0.000	ORBPOW	100.000	DELTA X	0.522	ALPHA I	0.000	MACH	5.010	ELVBST	0.000	ELVORS	0.000	BETA	0.000	<table border="0" style="width: 100%;"> <tr> <th colspan="3" style="text-align: left;">REFERENCE INFORMATION</th> </tr> <tr> <td>REFS</td> <td>23.6890</td> <td>SQ IN</td> </tr> <tr> <td>REFL</td> <td>4.1930</td> <td>IN</td> </tr> <tr> <td>REFB</td> <td>6.5000</td> <td>IN</td> </tr> <tr> <td>XMRP</td> <td>4.9170</td> <td>IN</td> </tr> <tr> <td>YMRP</td> <td>0.0000</td> <td>IN</td> </tr> <tr> <td>ZMRP</td> <td>1.3900</td> <td>IN</td> </tr> <tr> <td>SCALE</td> <td>0.0055</td> <td></td> </tr> </table>	REFERENCE INFORMATION			REFS	23.6890	SQ IN	REFL	4.1930	IN	REFB	6.5000	IN	XMRP	4.9170	IN	YMRP	0.0000	IN	ZMRP	1.3900	IN	SCALE	0.0055	
PARAMETRIC VALUES																																															
9STFOW	0.000	ORBPOW	100.000																																												
DELTA X	0.522	ALPHA I	0.000																																												
MACH	5.010	ELVBST	0.000																																												
ELVORS	0.000	BETA	0.000																																												
REFERENCE INFORMATION																																															
REFS	23.6890	SQ IN																																													
REFL	4.1930	IN																																													
REFB	6.5000	IN																																													
XMRP	4.9170	IN																																													
YMRP	0.0000	IN																																													
ZMRP	1.3900	IN																																													
SCALE	0.0055																																														

REFERENCE FILE

# AEDC VA 1163 MDAC BOOSTER AND ORBITER TEST DATA AT MACH NUMBER 5

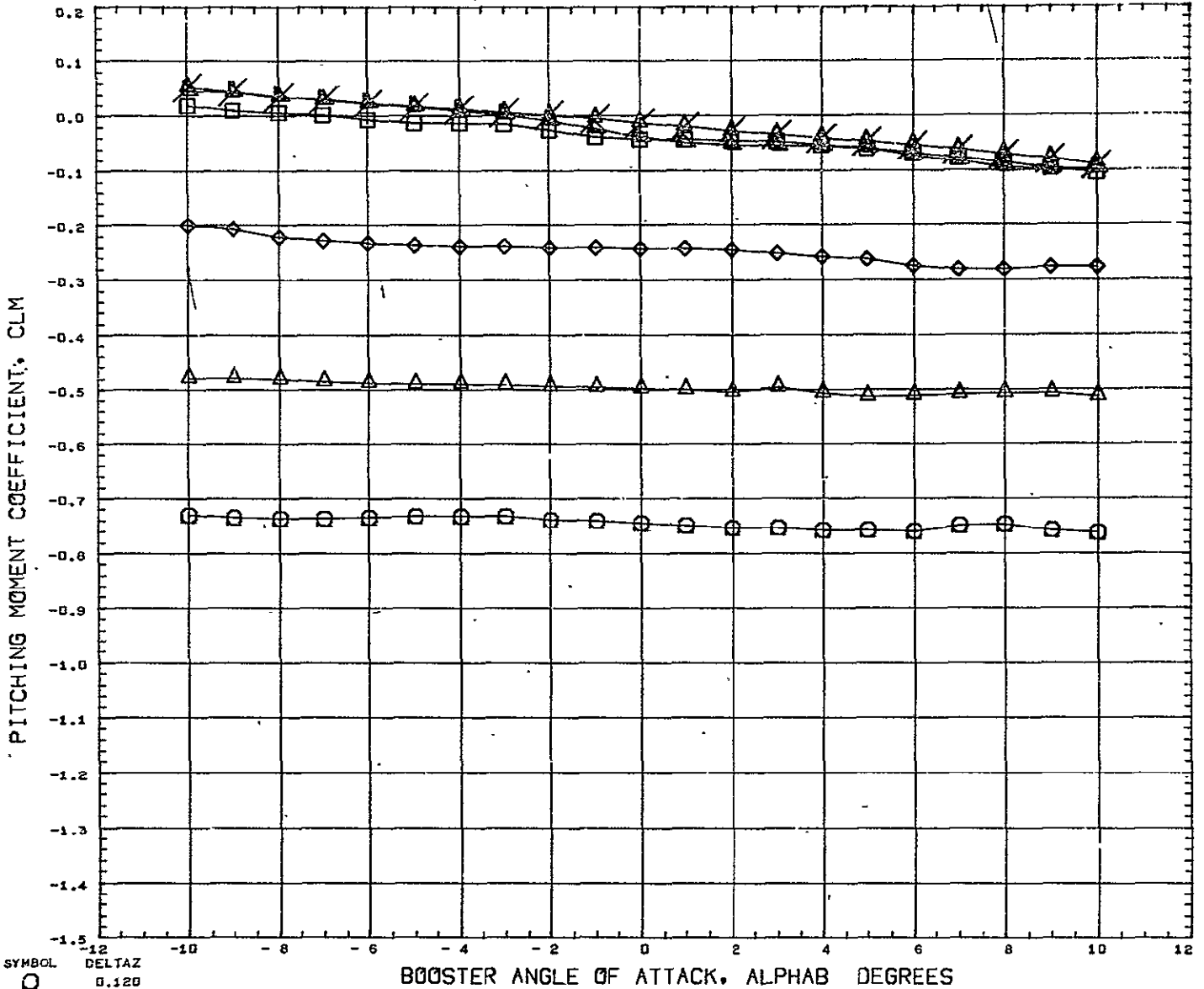

SYMBOL ○ ◇ △ □ ▽	DELTAZ 0.120 0.151 0.182 0.228 0.352 10.000	PARAMETRIC VALUES 75IPOW 50.000 ORBPOW 50.000 DELTAX - 0.391 ALPHAI 0.000 MACH 5.010 ELVBST 0.000 ELVORB 0.000 BETA 0.000	REFERENCE INFORMATION REFS 23.6890 SQ IN REFL 4.1930 IN REFB 6.5000 IN XMRP 4.9170 IN YMRP 0.0000 IN ZMRP 1.3900 IN SCALE 0.0055
REFERENCE FILE			

# AEDC VA 1163 MDAC BOOSTER AND ORBITER TEST DATA AT MACH NUMBER 5

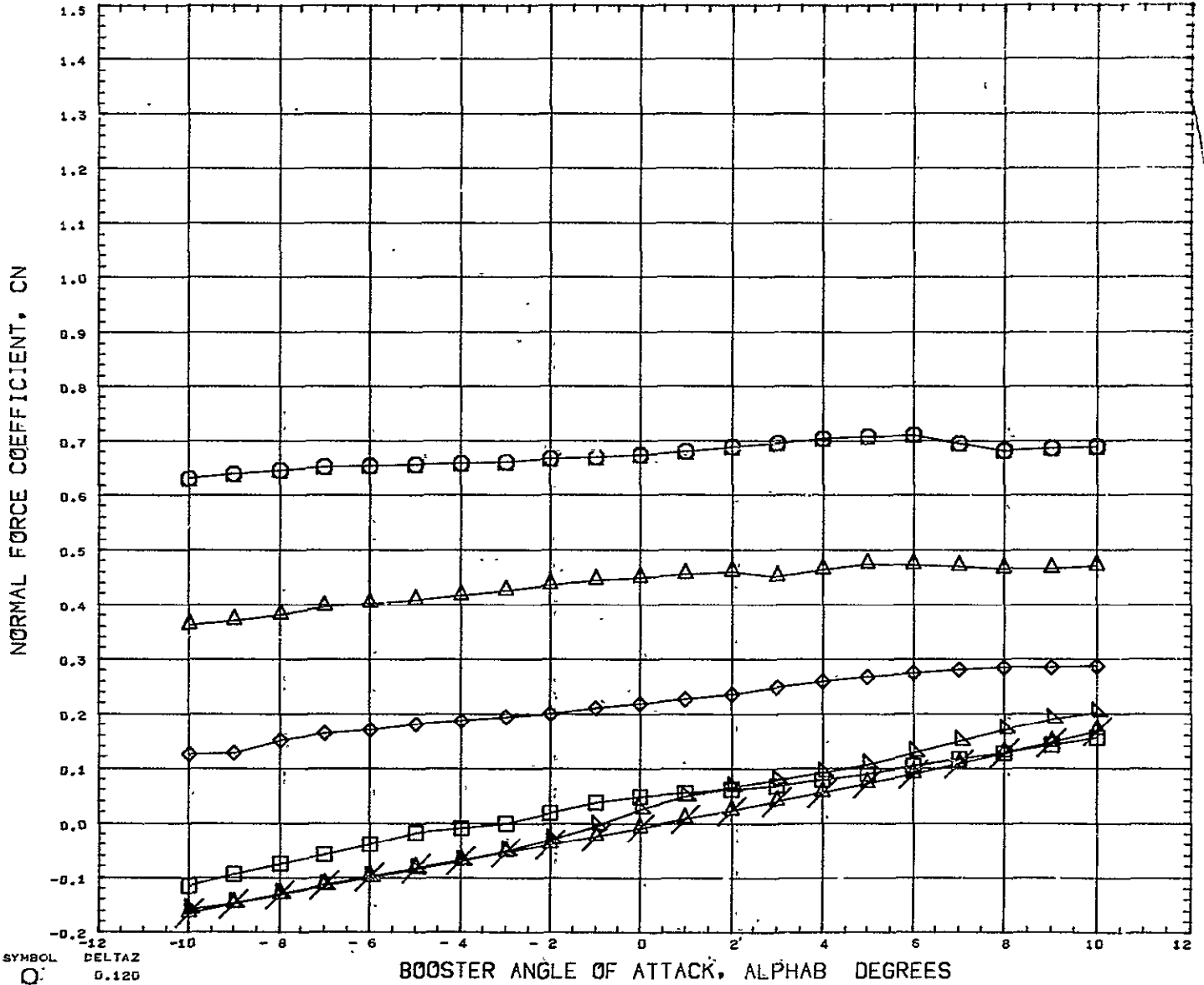

SYMBOL	DELTA Z	PARAMETRIC VALUES				REFERENCE INFORMATION		
○	0.120	.STPOW	50.000	ORBFOW	50.000	REFS	23.6890	SQ IN
△	0.151	DELTA X	0.391	ALPHA I	0.000	REFL	4.1930	IN
◇	0.182	MACH	5.010	ELVBST	0.000	REFB	6.5050	IN
□	0.352	ELVORB	0.000	BETA	0.000	XMRP	4.9170	IN
×	10.000					YMRP	0.0000	IN
						ZMRP	1.3900	IN
						SCALE	0.0055	

REFERENCE FILE

# AEDC VA 1163 MDAC BOOSTER AND ORBITER TEST DATA AT MACH NUMBER 5

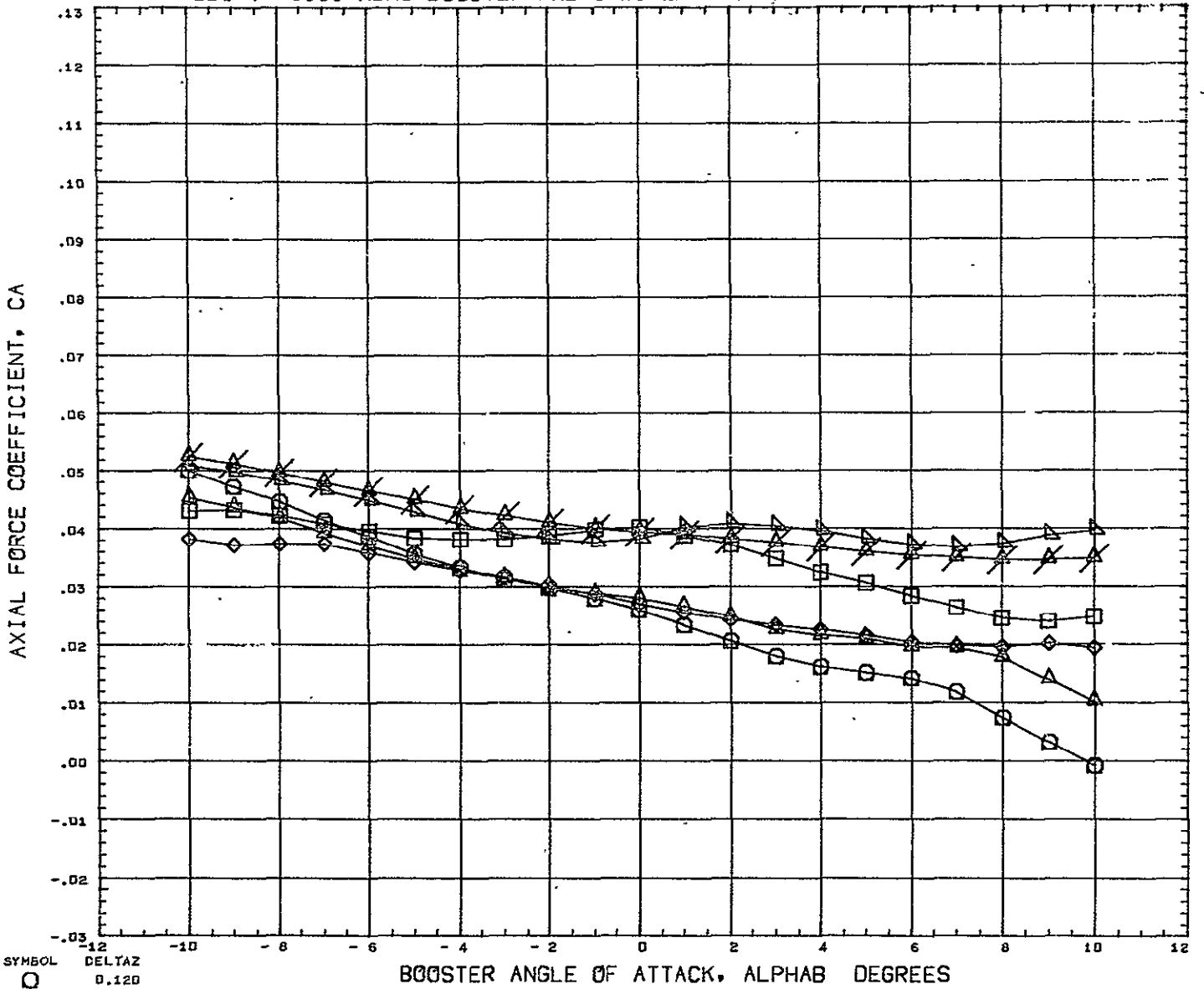

<p>SYMBOL</p> <p>○</p> <p>△</p> <p>◇</p> <p>□</p> <p>▽</p>	<p>DELTA Z</p> <p>0.120</p> <p>0.151</p> <p>0.182</p> <p>0.228</p> <p>0.352</p> <p>10.000</p>	<p style="text-align: center;">PARAMETRIC VALUES</p> <table border="0" style="width: 100%;"> <tr> <td>BSTPOW</td> <td>50.000</td> <td>ORBPOW</td> <td>50.000</td> </tr> <tr> <td>DELTA X</td> <td>0.391</td> <td>ALPHA 1</td> <td>0.000</td> </tr> <tr> <td>MACH</td> <td>5.010</td> <td>ELVBST</td> <td>0.000</td> </tr> <tr> <td>ELVORB</td> <td>0.000</td> <td>BETA</td> <td>0.000</td> </tr> </table>	BSTPOW	50.000	ORBPOW	50.000	DELTA X	0.391	ALPHA 1	0.000	MACH	5.010	ELVBST	0.000	ELVORB	0.000	BETA	0.000	<p style="text-align: center;">REFERENCE INFORMATION</p> <table border="0" style="width: 100%;"> <tr> <td>REFS</td> <td>23.6890</td> <td>SQ IN</td> </tr> <tr> <td>REFL</td> <td>4.1930</td> <td>IN</td> </tr> <tr> <td>REFB</td> <td>6.5000</td> <td>IN</td> </tr> <tr> <td>XMRP</td> <td>4.9170</td> <td>IN</td> </tr> <tr> <td>YMRP</td> <td>0.0000</td> <td>IN</td> </tr> <tr> <td>ZMRP</td> <td>1.3900</td> <td>IN</td> </tr> <tr> <td>SCALE</td> <td>0.0055</td> <td></td> </tr> </table>	REFS	23.6890	SQ IN	REFL	4.1930	IN	REFB	6.5000	IN	XMRP	4.9170	IN	YMRP	0.0000	IN	ZMRP	1.3900	IN	SCALE	0.0055	
BSTPOW	50.000	ORBPOW	50.000																																					
DELTA X	0.391	ALPHA 1	0.000																																					
MACH	5.010	ELVBST	0.000																																					
ELVORB	0.000	BETA	0.000																																					
REFS	23.6890	SQ IN																																						
REFL	4.1930	IN																																						
REFB	6.5000	IN																																						
XMRP	4.9170	IN																																						
YMRP	0.0000	IN																																						
ZMRP	1.3900	IN																																						
SCALE	0.0055																																							

REFERENCE FILE

# AEDC VA 1163 MDAC BOOSTER AND ORBITER TEST DATA AT MACH NUMBER 5

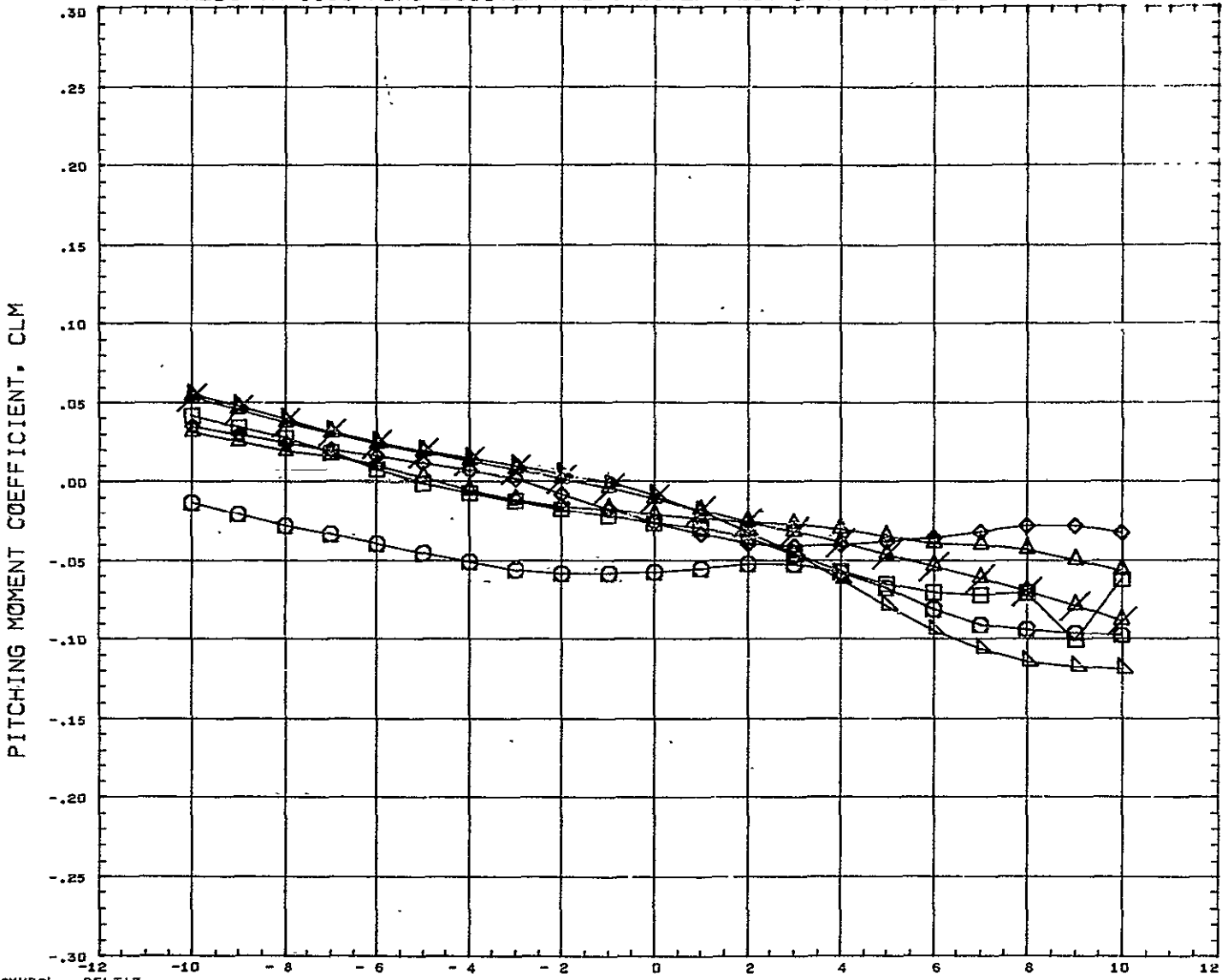

SYMBOL ○ □ △ ×	DELTA Z 0.120 0.151 0.182 0.228 0.352 10.000	PARAMETRIC VALUES BSTPOW 50.000 ORBPOW 50.000 DELTAX - 9.143 ALPHAI 0.000 MACH 5.010 ELVBST 0.000 ELVORB 0.000 BETA 0.000	REFERENCE INFORMATION REFS 23.6890 SQ IN REFL 4.1930 IN REFB 6.5000 IN XMRP 4.9176 IN YMRP 0.0000 IN ZMRP 1.3900 IN SCALE 0.0055
----------------------------	--	---	---

REFERENCE FILE



# AEDC VA 1163 MDAC BOOSTER AND ORBITER TEST DATA AT MACH NUMBER 5

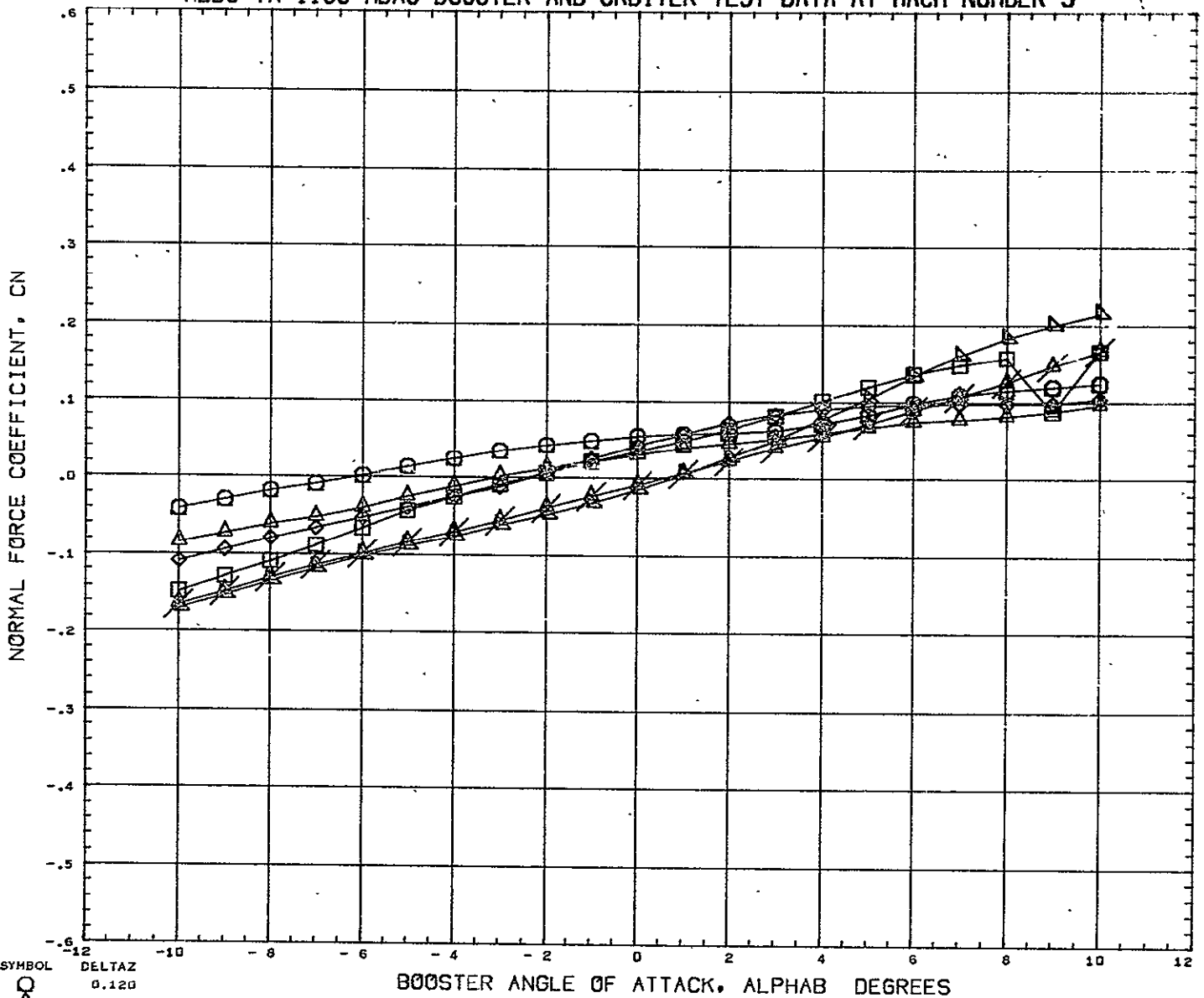

SYMBOL ○ ◇ □ △	DELTAX 0.120 0.151 0.162 0.228 0.352 10.000	PARAMETRIC VALUES BSTFOW 50.000 ORBPOW 50.000 DELTAX - 0.143 ALPHAI 0.000 MACH 5.010 ELYBST 0.000 ELVORB 0.000 BETA 0.000	REFERENCE INFORMATION REFS 23.6890 SQ IN REFL 4.1930 IN REFB 6.5000 IN XMRT 4.9170 IN YMRP 0.0000 IN ZMRP 1.3900 IN SCALE 0.0055
REFERENCE FILE			

AEDC VA 1163 MDAC BOOSTER AND ORBITER TEST DATA AT MACH NUMBER 5

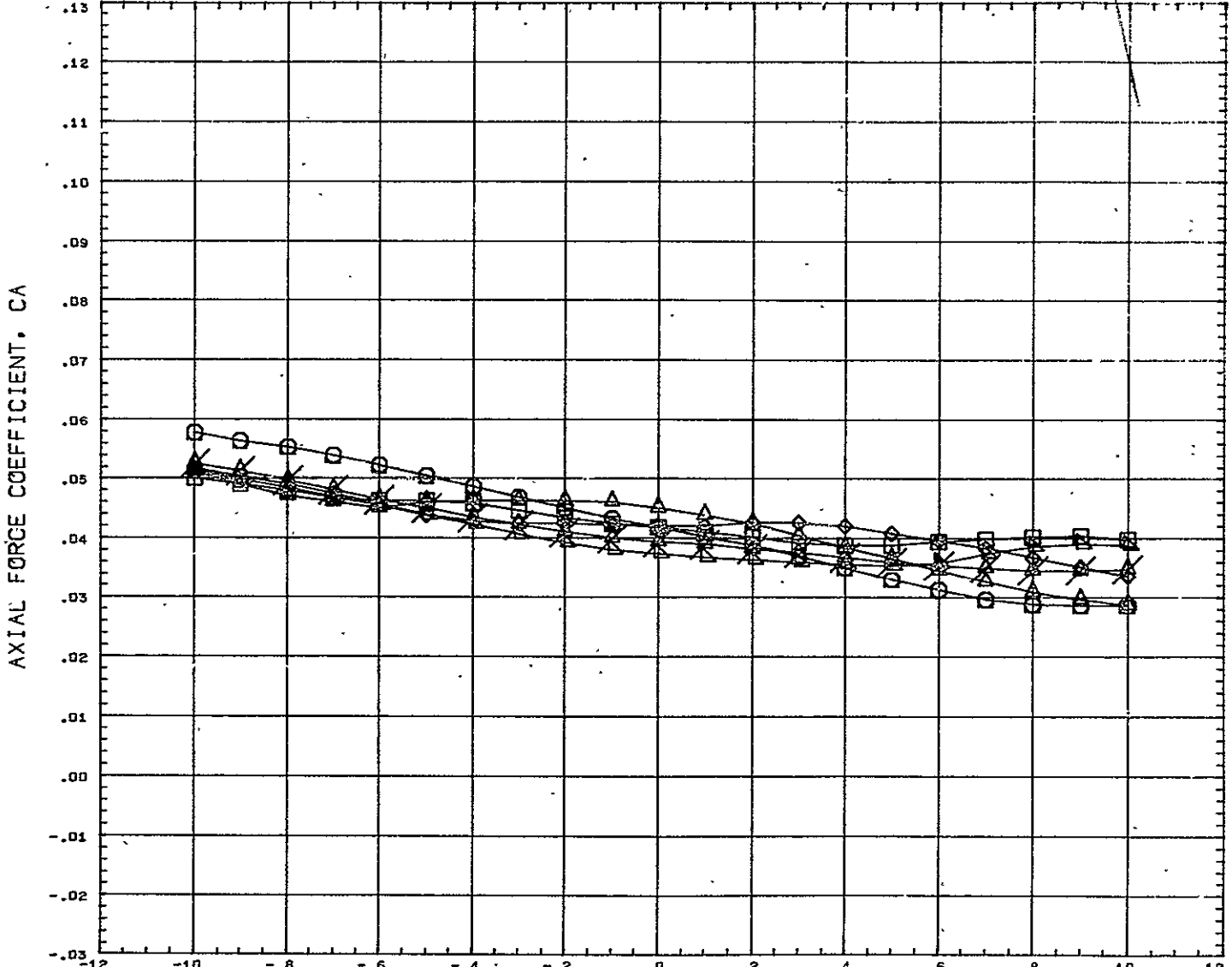

SYMBOL	DELTA Z	PARAMETRIC VALUES				REFERENCE INFORMATION		
○	0.120							
◇	0.151							
□	0.182	BSTPOW	50.000	ORBPOW	50.000	REFS	23.6890	SQ IN
△	0.228	DELTA Z	0.143	ALPHA I	0.000	REFL	4.1930	IN
	0.352	MACH	5.010	ELVBST	0.000	REFB	6.5000	IN
	10.000	ELVORB	0.000	BETA	0.000	XMRP	4.9170	IN
						YMRP	0.0000	IN
						ZMRP	1.3900	IN
						SCALE	0.0055	

REFERENCE FILE

# AEDC VA 1163 MDAC BOOSTER AND ORBITER TEST DATA AT MACH NUMBER 5

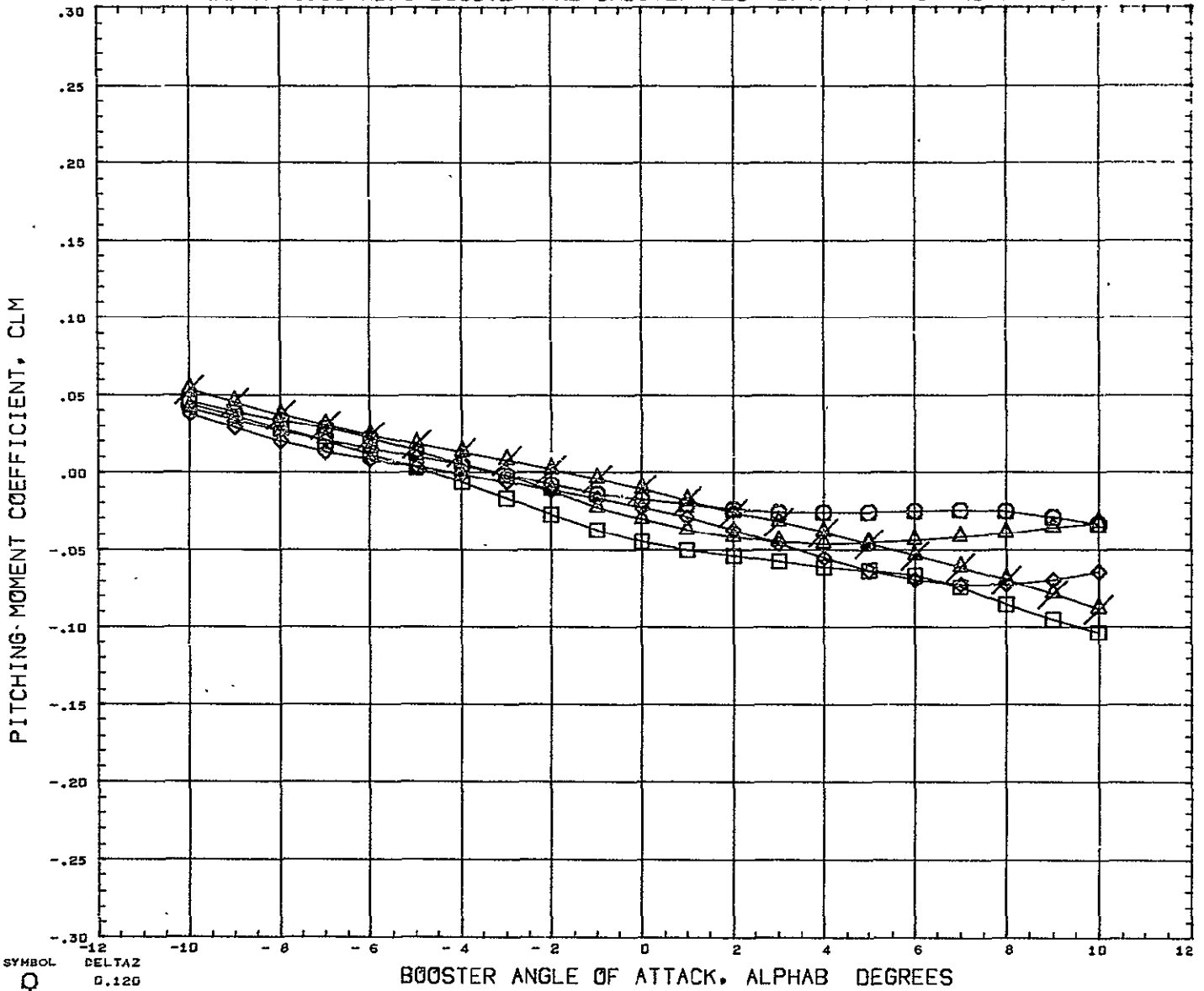

SYMBOL	DELTA Z
○	0.120
△	0.151
◇	0.182
□	0.228
⊗	10.000

PARAMETRIC VALUES			
3STFOW	50.000	ORBPOW	50.000
DELTA X	0.019	ALPHA I	0.000
MACH	5.010	ELVBST	0.000
ELVORB	0.000	BETA	0.000

REFERENCE INFORMATION		
REFS	23.6890	SQ IN
REFL	4.1930	IN
REFB	6.5000	IN
XMRP	4.9170	IN
YMRP	0.0000	IN
ZMRP	1.3900	IN
SCALE	0.0055	

REFERENCE FILE

# AEDC VA 1163 MDAC BOOSTER AND ORBITER TEST DATA AT MACH NUMBER 5

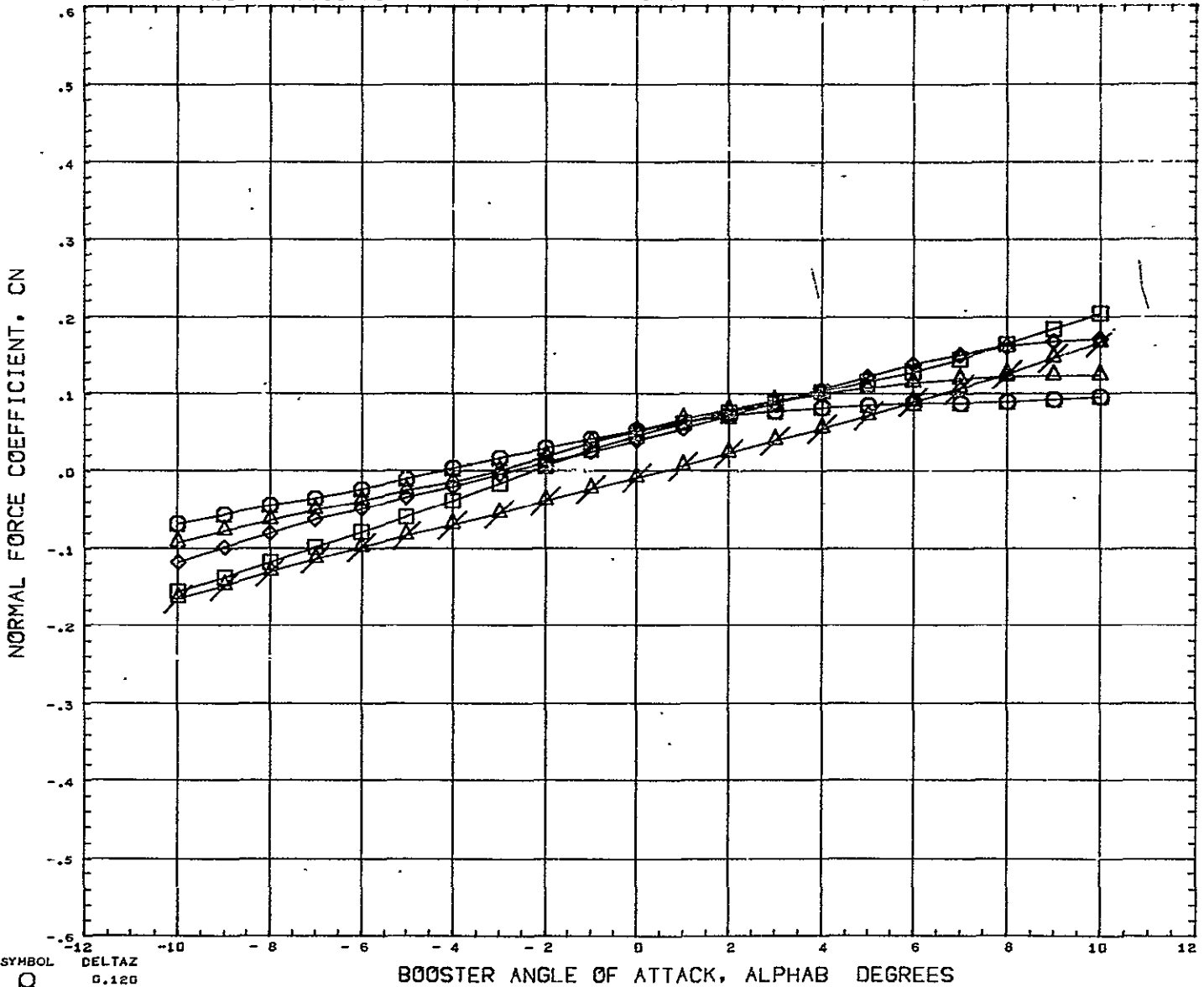

SYMBOL ○ ◇ □ △ ×	DELTAZ 0.120 0.151 0.182 0.228 10.000	PARAMETRIC VALUES BSTPOW 50.000 ORBPOW 50.000 DELTAX - 0.019 ALPHAI 0.000 MACH 5.015 ZLVBST 0.000 ELVORB 0.000 BETA 0.000	REFERENCE INFORMATION REFS 23.6890 SQ IN REFL 4.1936 IN REFB 6.5000 IN XMRP 4.9170 IN YMRP 0.0000 IN ZMRP 1.3900 IN SCALE 0.0055
REFERENCE FILE			

# AEDC VA 1163 MDAC BOOSTER AND ORBITER TEST DATA AT MACH NUMBER 5

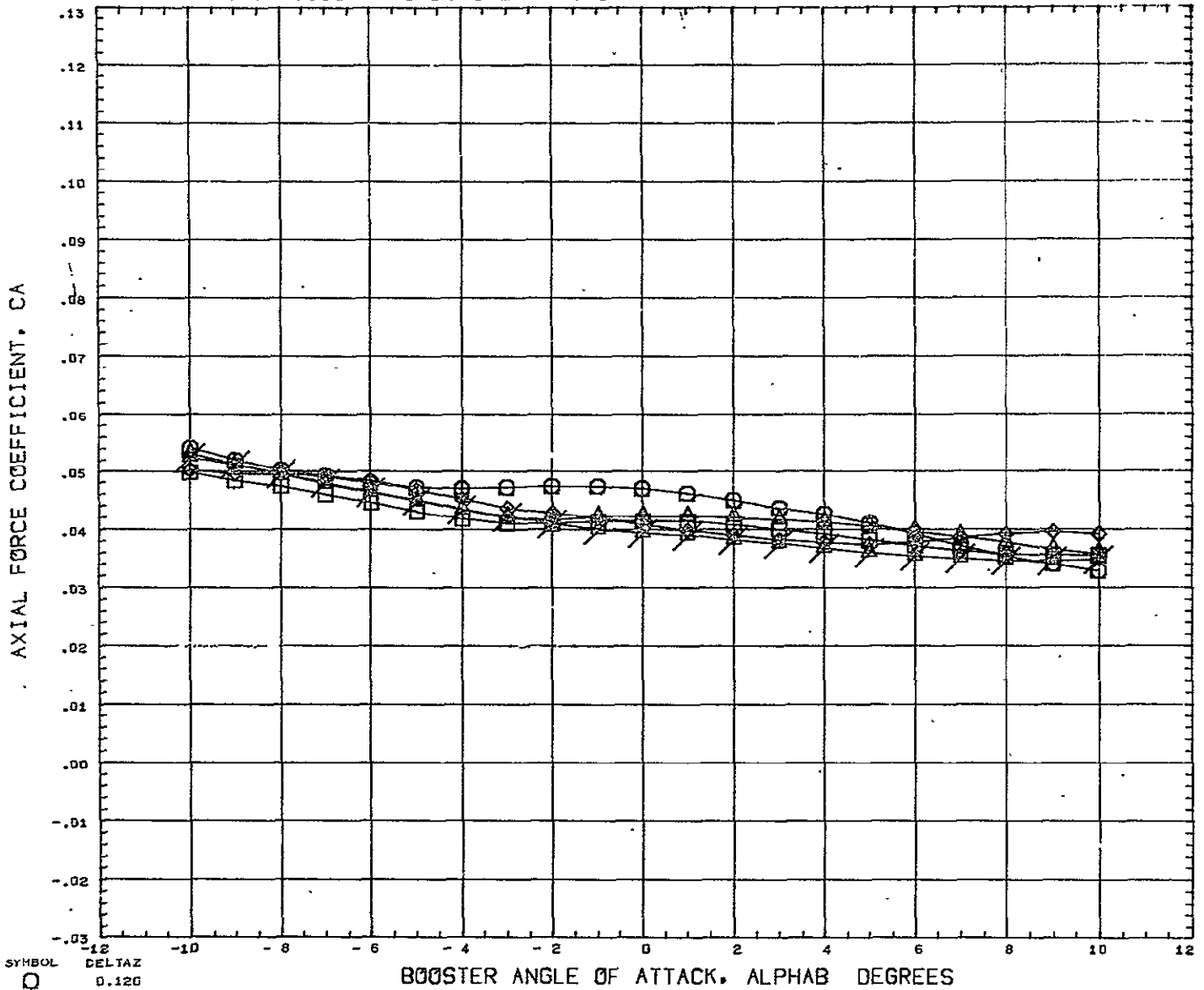

SYMBOL ○ ◇ □ △ X	DELTA Z 0.120 0.151 0.102 0.228 10.000	PARAMETRIC VALUES 3STPOW 50.000 ORBPOW 50.000 DELTAX - 0.019 ALPHA1 0.000 MACH 5.010 ELVBST 0.000 ELVORB 0.000 BETA 0.000	REFERENCE INFORMATION REFS 23.6890 SQ IN REFL 4.1930 IN REFB 6.9000 IN XMRP 4.9170 IN YMRP 0.0000 IN ZMRP 1.3900 IN SCALE 0.0055
---------------------------------	---	---	---

REFERENCE FILE

# AEDC VA 1163 MDAC BOOSTER AND ORBITER TEST DATA AT MACH NUMBER 5

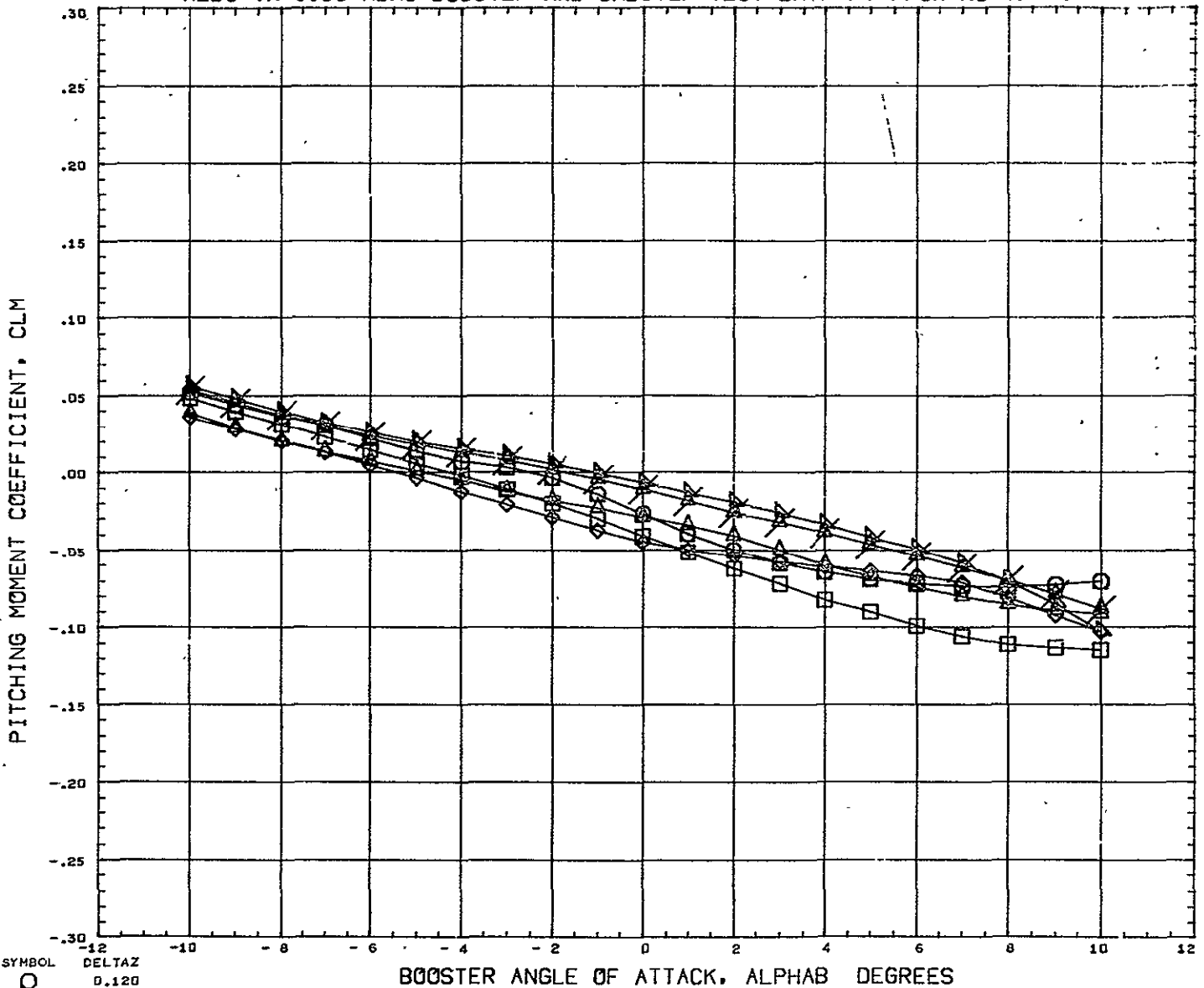

SYMBOL ○ □ △ ◇ ×	DELTAZ 0.120 0.151 0.182 0.228 0.352 10.000	PARAMETRIC VALUES 3STPOW 50.000 ORBPOW 50.000 DELTAX 0.104 ALPHAI 0.000 MACH 5.010 ELVBST 0.000 ELVORB 0.000 BETA 0.000	REFERENCE INFORMATION REFS 23.6890 SQ IN REFL 4.1930 IN REFB 6.5000 IN XNRP 4.9170 IN YNRP 0.0000 IN ZNRP 1.3900 IN SCALE 0.0055
---------------------------------	---	---	---

REFERENCE FILE

# AEDC VA 1163 MDAC BOOSTER AND ORBITER TEST DATA AT MACH NUMBER 5

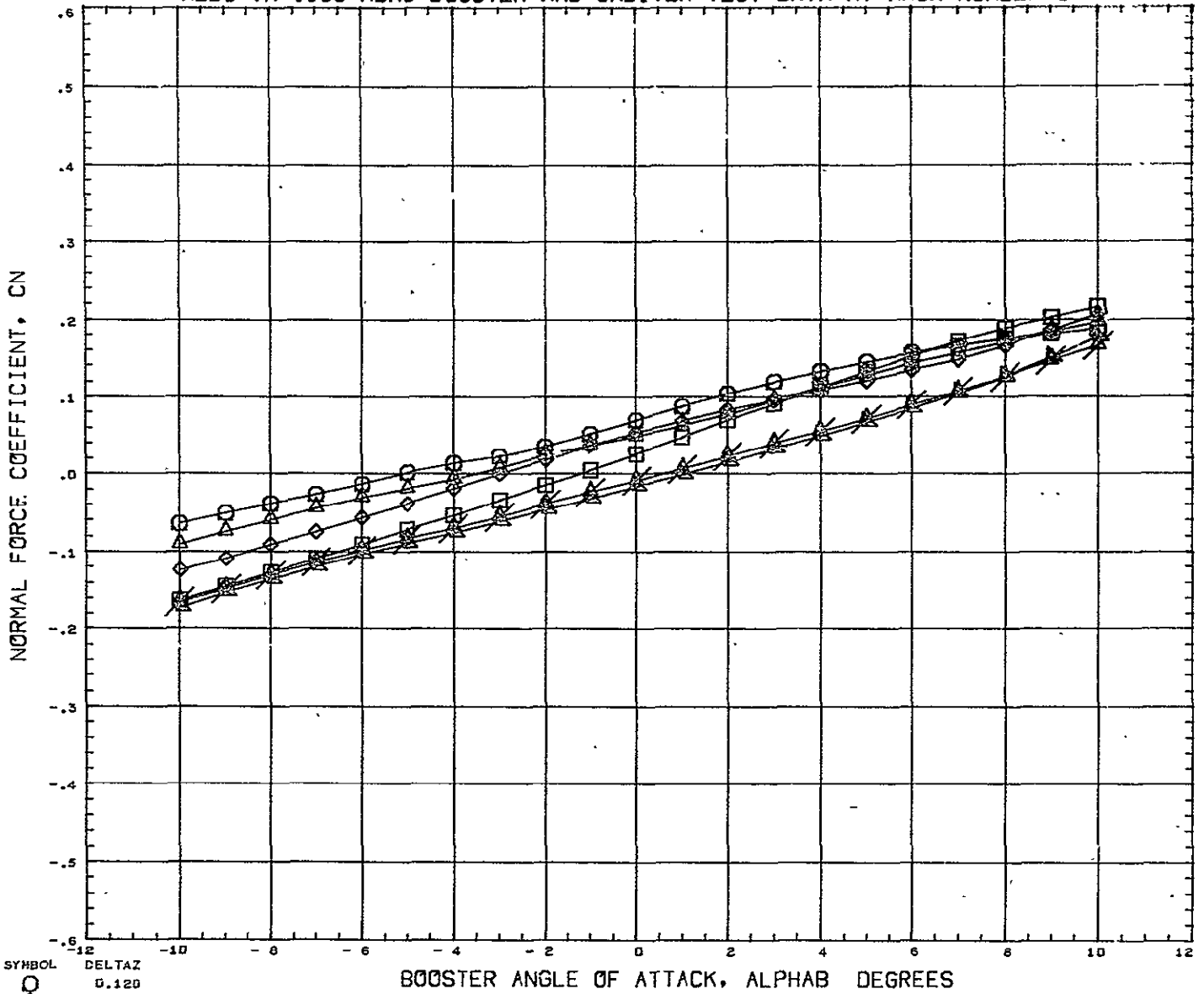

SYMBOL ○ ◇ □ △ ×	DELTAX 0.120 0.151 0.182 0.228 0.352 10.000	PARAMETRIC VALUES BSTPOW 50.000 ORBPOW 50.000 DELTAX 0.104 ALPHAI 0.000 MACH 5.010 ELVBST 0.000 ELVORB 0.000 BETA 0.000	REFERENCE INFORMATION REFS 23.6890 SQ IN REFL 4.1930 IN REFB 6.5000 IN XMRP 4.9170 IN YMRP 0.0000 IN ZMRP 1.3900 IN SCALE 0.0055
---------------------------------	---	---	---

REFERENCE FILE

# AEDC VA 1163 MDAC BOOSTER AND ORBITER TEST DATA AT MACH NUMBER 5

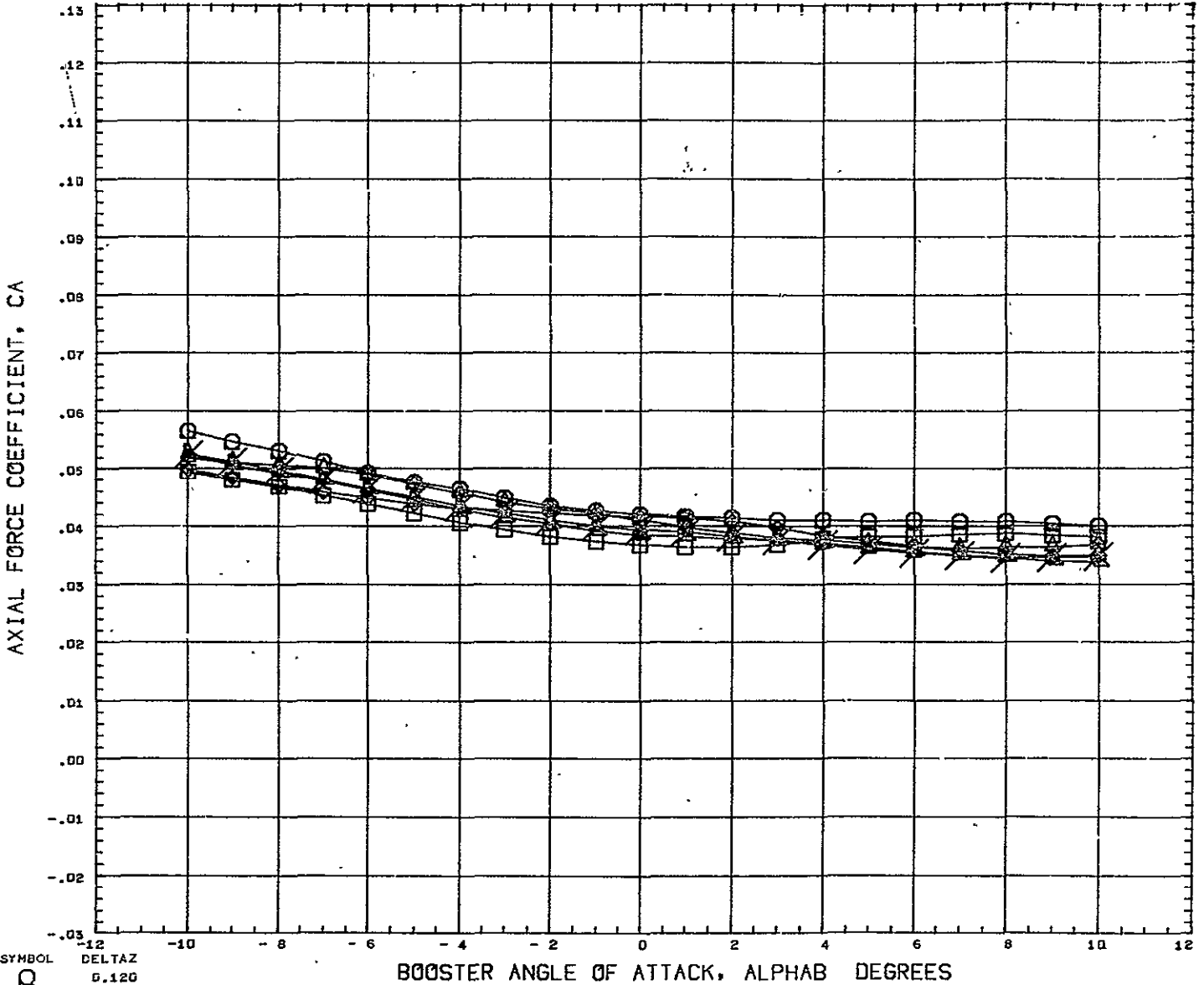

SYMBOL ○ ◊ □ △	DELTAZ 0.120 0.151 0.182 0.228 0.352 10.000	PARAMETRIC VALUES BSTPOW 50.000 ORBPOW 50.000 DELTAX 0.104 ALPHAI 0.000 MACH 5.010 ELVBST 0.000 ELVORB 0.000 BETA 0.000	REFERENCE INFORMATION REFS 23.6890 SQ IN REFL 4.1930 IN REFB 6.5000 IN XMRP 4.9170 IN YMRP 0.0000 IN ZMRP 1.3900 IN SCALE 0.0055
----------------------------	---	---	---

REFERENCE FILE .



# AEDC VA 1163 MDAC BOOSTER AND ORBITER TEST DATA AT MACH NUMBER 5

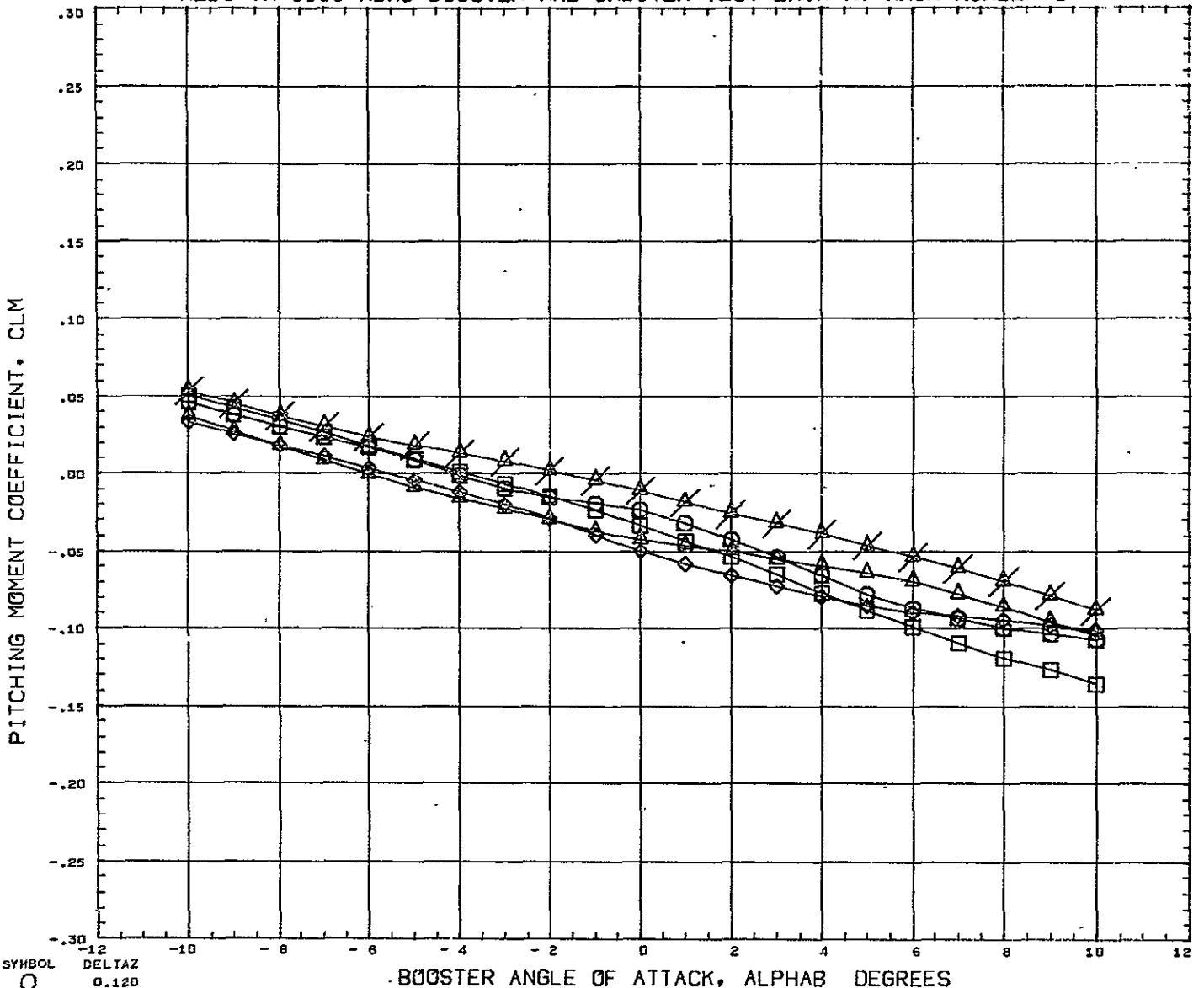

SYMBOL ○ △ □ ◇ ×	DELTAZ 0.120 0.151 0.182 0.228 10.000	PARAMETRIC VALUES BSTPOW 50.000 ORBPOW 50.000 DELTAX 0.166 ALPHA: 0.000 MACH 5.010 ELVEST 0.000 ELVORB 0.000 BETA 0.000	REFERENCE INFORMATION REFS 23.6890 60 IN REFL 4.1930 IN REFB 6.5000 IN XMRP 4.9170 IN YMRP 0.0000 IN ZMRP 1.3900 IN SCALE 0.0055
---------------------------------	--	---	---

REFERENCE FILE

# AEDC VA 1163 MDAC BOOSTER AND ORBITER TEST DATA AT MACH NUMBER 5

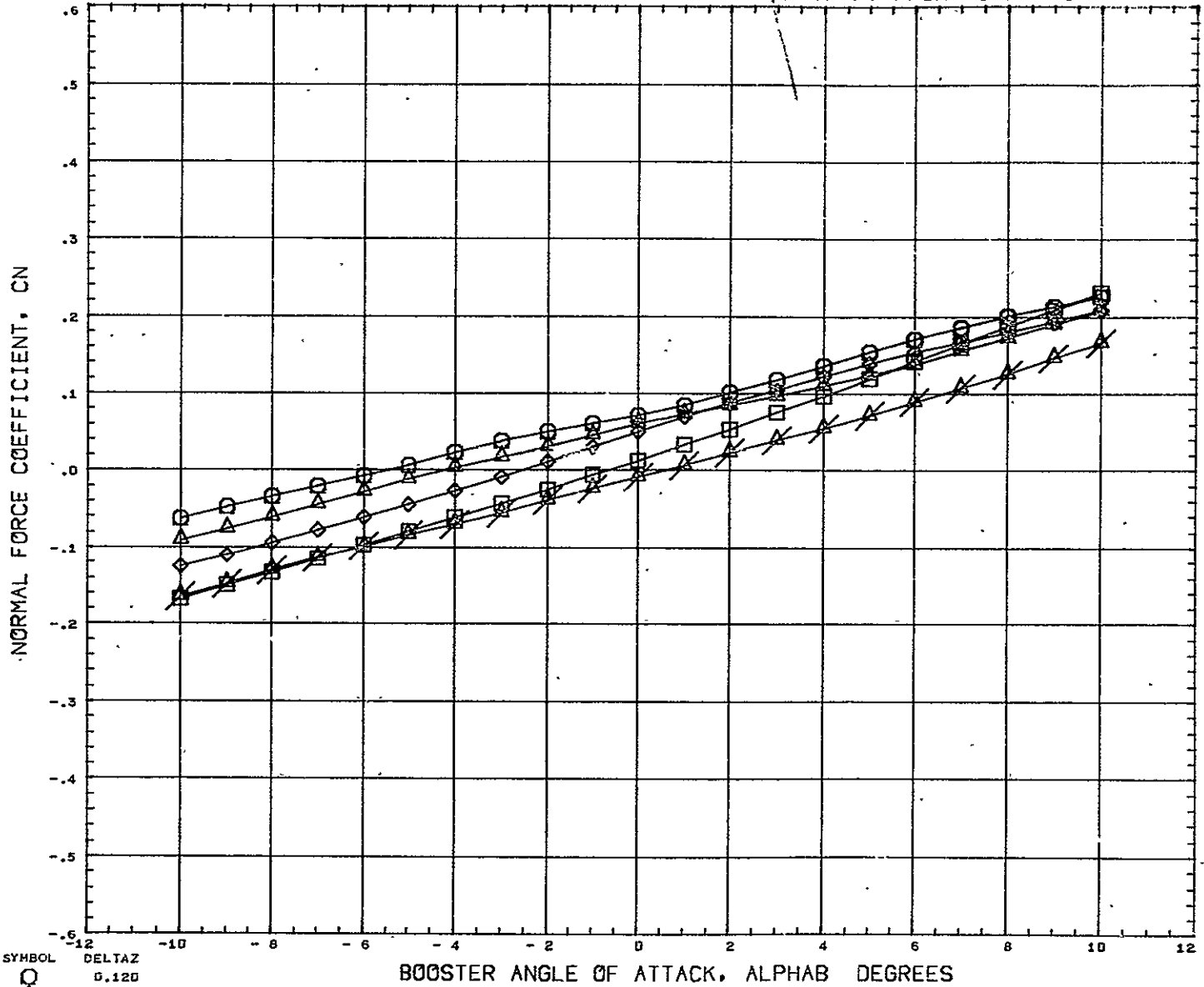

SYMBOL ○ △ ◇ □ ×	DELTA Z 0.120 0.151 0.182 0.228 10.000	PARAMETRIC VALUES βSTPCW 50.000 ORBPCW 50.000 DELTAX 0.166 ALPHAI 0.000 MACH 5.010 ELVBST 0.000 ELVORB 0.000 BETA 0.000	REFERENCE INFORMATION REFS 23.6890 SQ IN REFL 4.1930 IN REFB 6.5000 IN XMRP 4.9170 IN YMRP 0.0000 IN ZMRP 1.3900 IN SCALE 0.0055
---------------------------------	---	---	---

REFERENCE FILE

# AEDC VA 1163 MDAC BOOSTER AND ORBITER TEST DATA AT MACH NUMBER 5

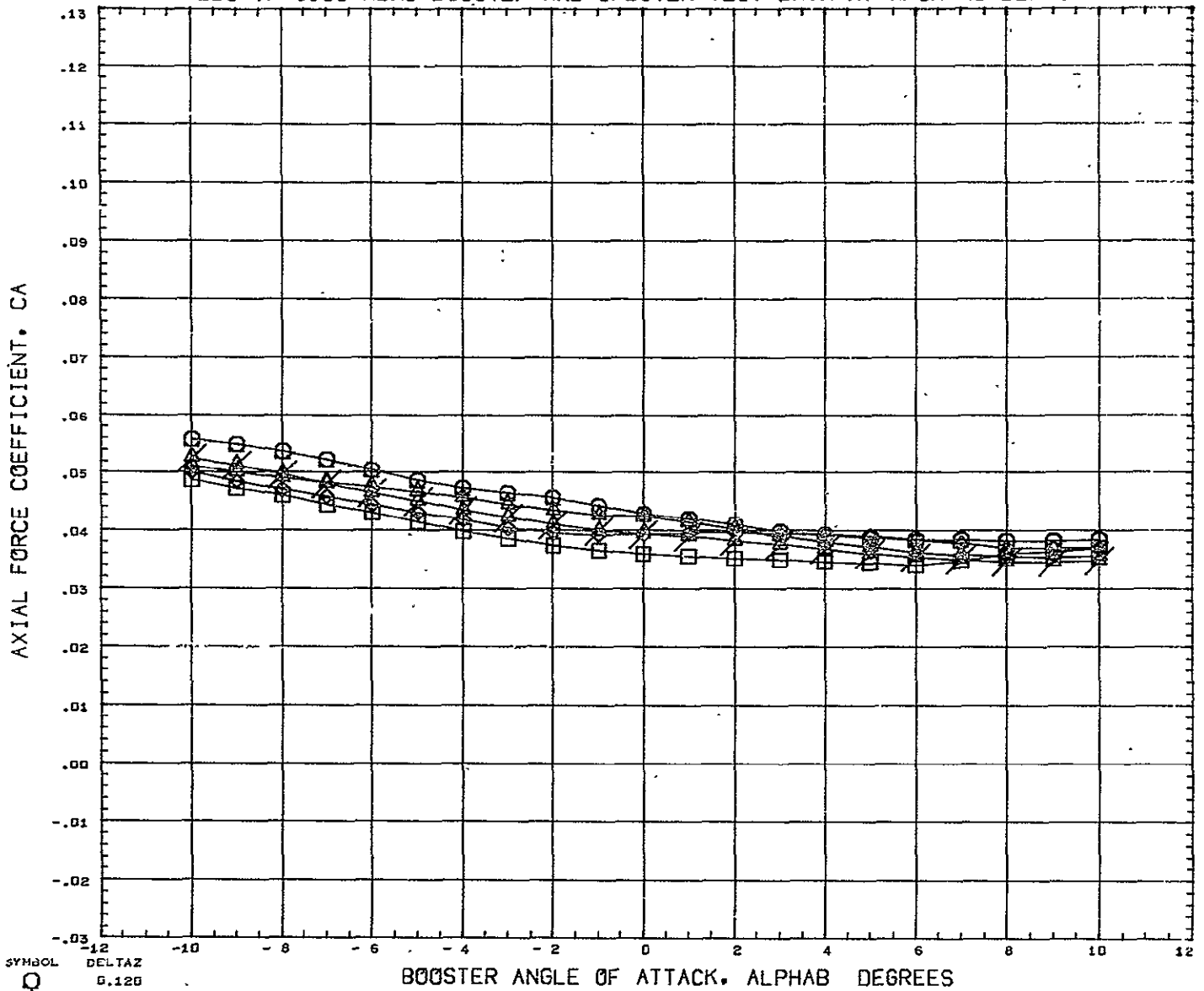

SYMBOL ○ ◇ △ □ X	DELTA Z 0.120 0.151 0.182 0.228 10.000	PARAMETRIC VALUES BSTFOW 50.000 ORB FOW 50.000 DELTAX 0.166 ALPHAI 0.000 MACH 5.010 ELVBST 0.000 ELVORB 0.000 BETA 0.000	REFERENCE INFORMATION REFS 23.6890 SQ IN REFL 4.1930 IN REFB 6.5000 IN XMRP 4.9170 IN YMRP 0.0000 IN ZMRP 1.3900 IN SCALE 0.0055
---------------------------------	---	--	---

REFERENCE FILE

# AEDC VA 1163 MDAC BOOSTER AND ORBITER TEST DATA AT MACH NUMBER 5

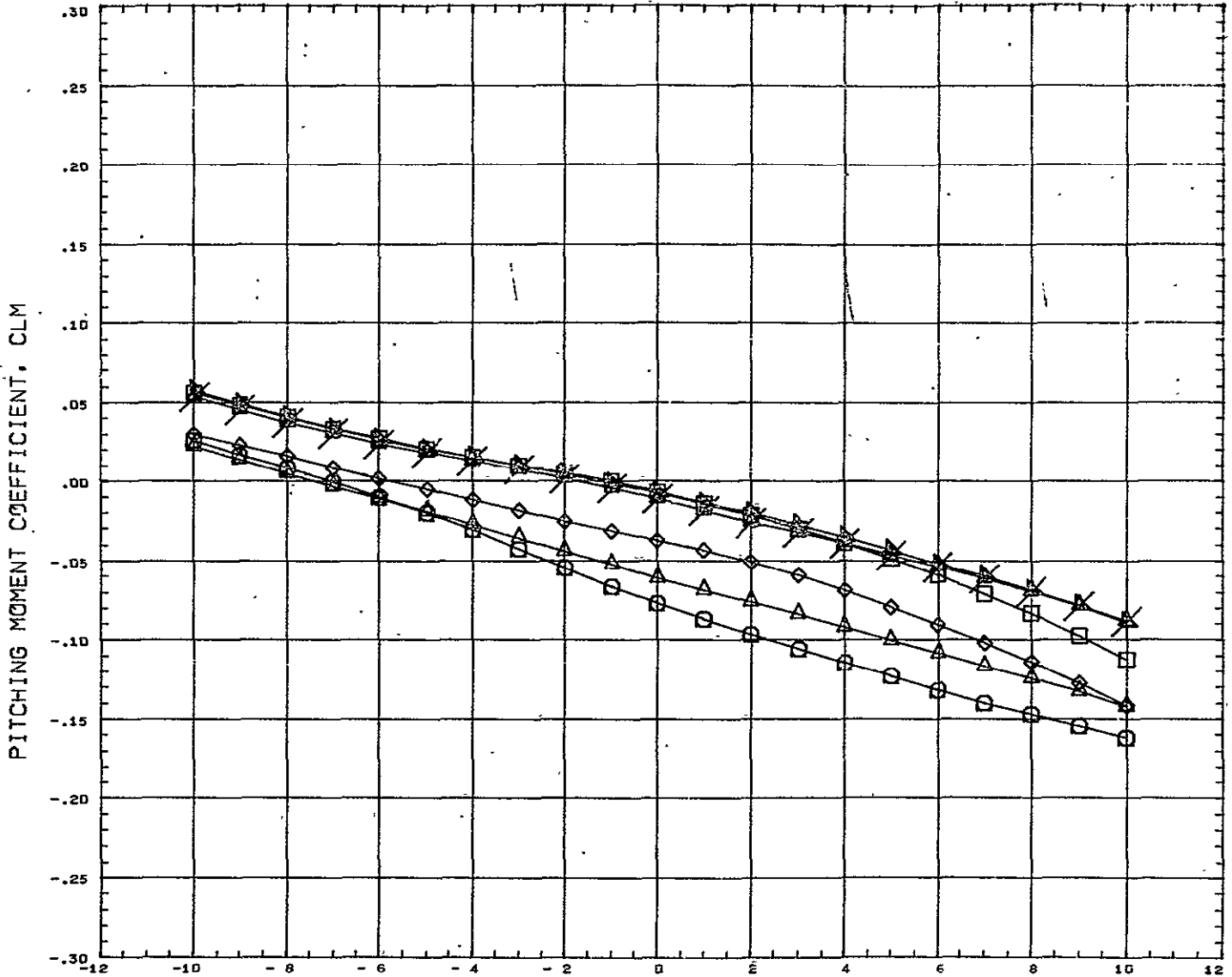

SYMBOL ○ □ △ ◇ ×	DELTAZ 0.120 0.151 0.182 0.228 0.352 10.000	PARAMETRIC VALUES BSTFOW 50.000 DELTAX 0.351 MACH 5.010 ELVORB 0.000 ORBPOW 50.000 ALPHAI 0.000 ELVBST 0.000 BETA 0.000	REFERENCE INFORMATION REFS 23.6890 SQ IN REFL 4.1930 IN REFB 6.5000 IN XMRF 4.9170 IN YMRP 0.0000 IN ZMRP 1.3900 IN SCALE 0.0055
---------------------------------	---	---	---

REFERENCE FILE

# AEDC VA 1163 MDAC BOOSTER AND ORBITER TEST DATA AT MACH NUMBER 5

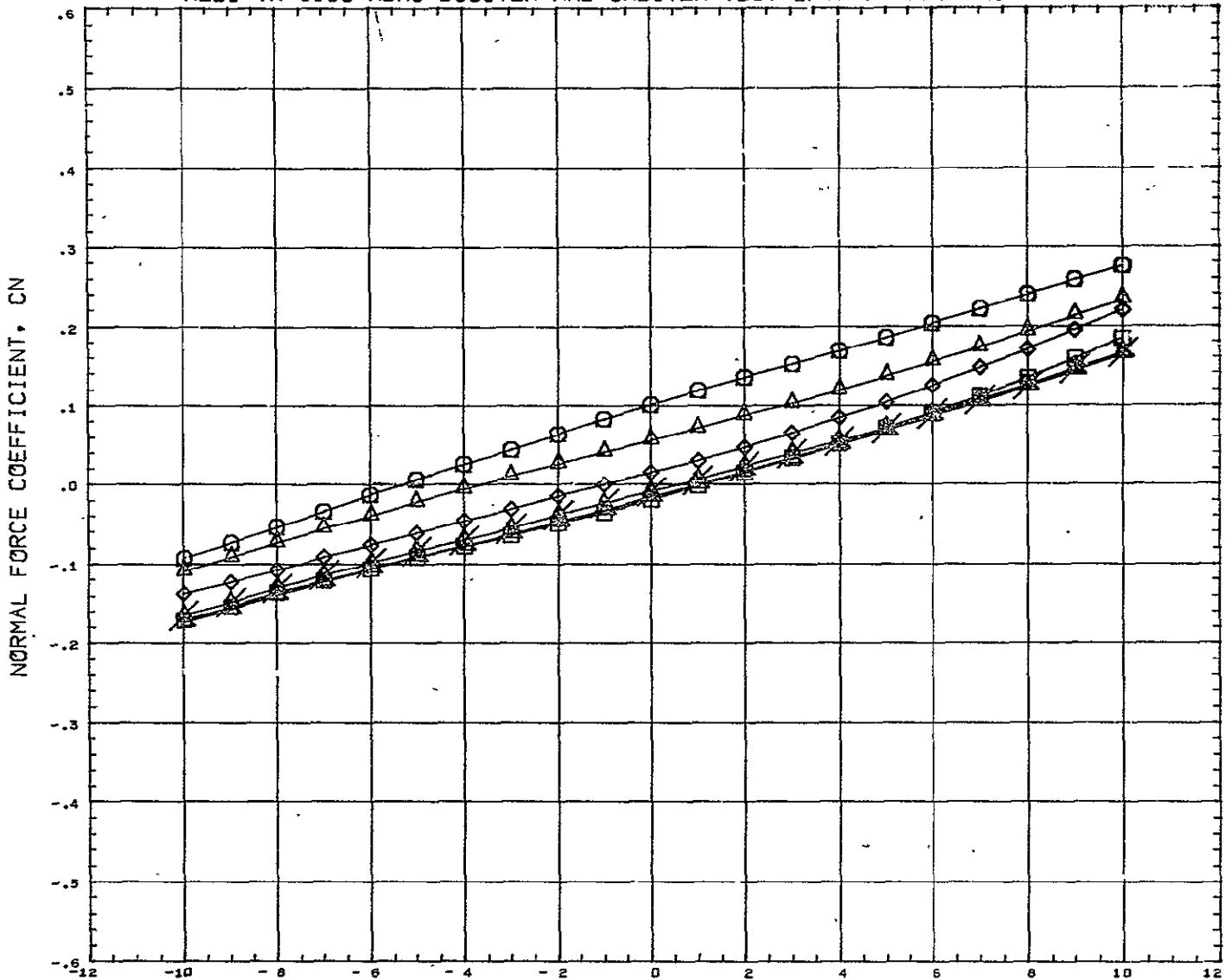

SYMBOL ○ △ ◇ □ ☆	DELTAX 0.120 0.151 0.182 0.228 0.352 10.000	PARAMETRIC VALUES BSTFOW 50.000 ORBPOW 50.000 DELTAX 0.351 ALPHAI 0.000 MACH 5.010 ELVBST 0.000 ELVORB 0.000 BETA 0.000	REFERENCE INFORMATION REFS 23.6890 SQ IN REFL 4.1930 IN REFB 6.5000 IN XMRP 4.9170 IN YMRP 0.0000 IN ZMRP 1.3900 IN SCALE 0.0055
REFERENCE FILE			

# AEDC VA 1163 MDAC BOOSTER AND ORBITER TEST DATA AT MACH NUMBER 5

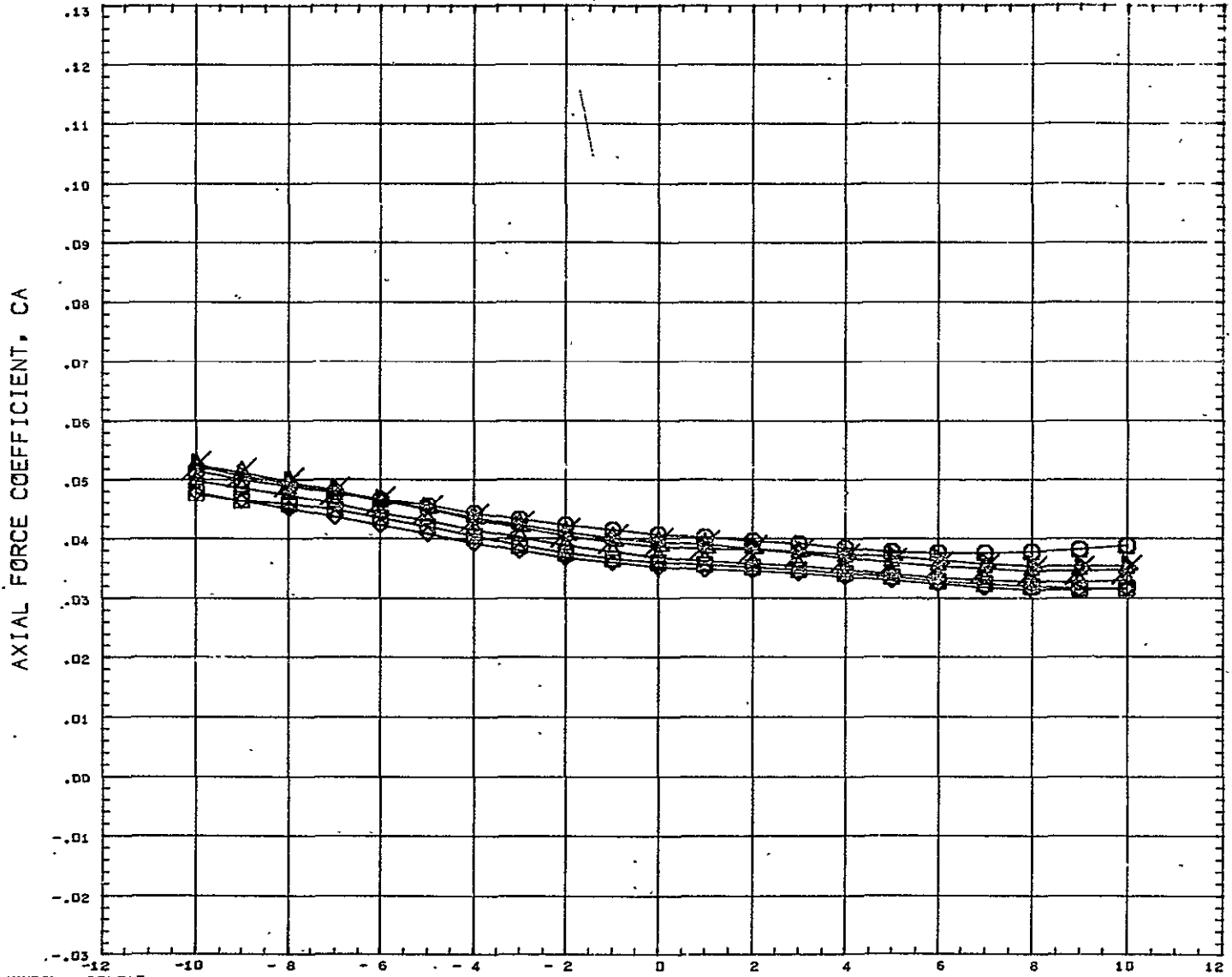

SYMBOL 	DELTAZ 0.120 0.151 0.182 0.220 0.352 10.000	DELTAX 0.351 MACH 5.010 ELVORB 0.000	PARAMETRIC VALUES	ORBPOW 50.000 ALPHAI 0.000 ELVBST 0.000 BETA 0.006	REFERENCE INFORMATION REFS 23.6890 SQ IN REFL 4.1930 IN REFB 6.5000 IN XMRP 4.9170 IN YMRP 0.0000 IN ZMRP 1.3900 IN SCALE 0.0055
------------	---	---	-------------------	---	---

REFERENCE FILE

# AEDC VA 1163 MDAC BOOSTER AND ORBITER TEST DATA AT MACH NUMBER 5

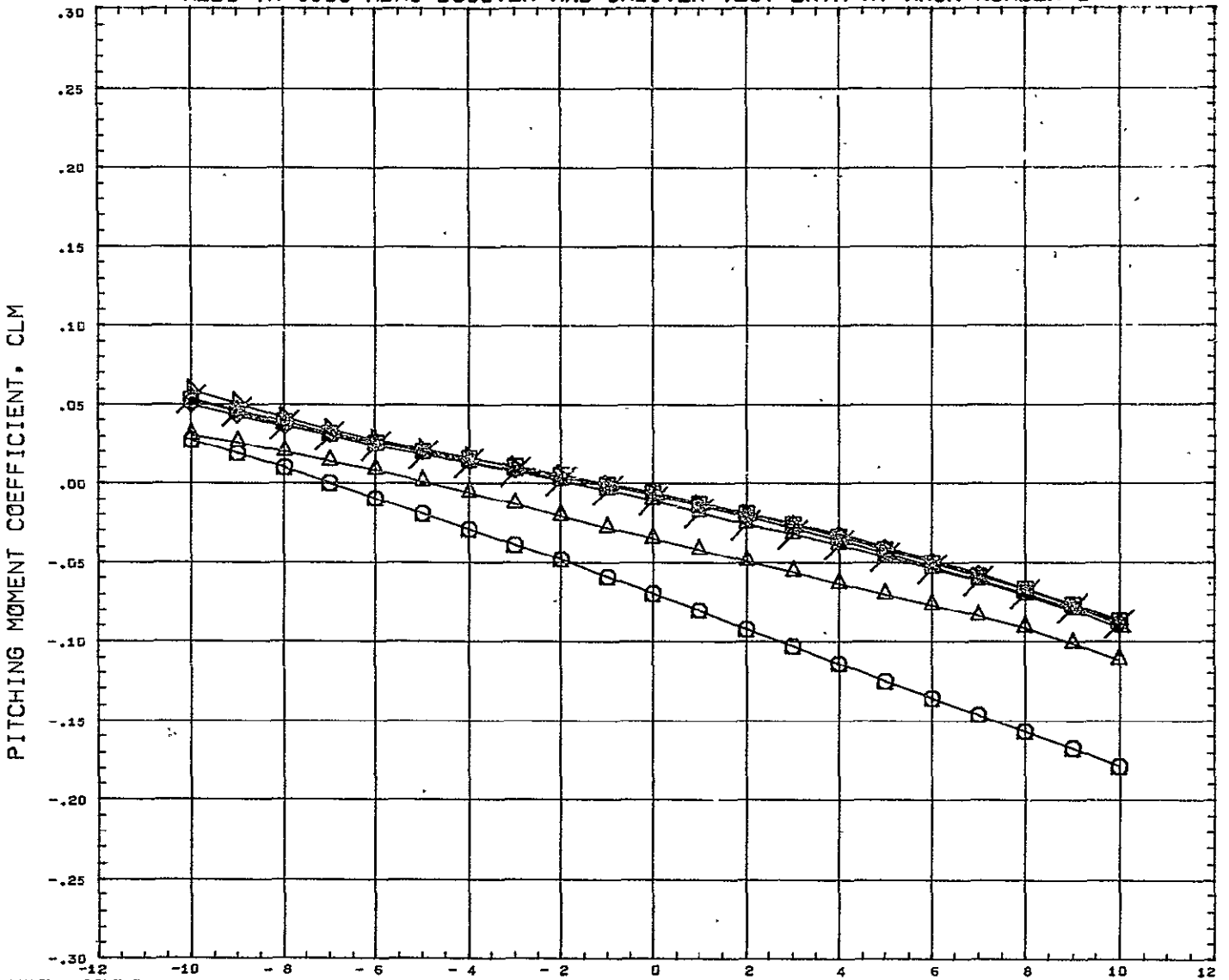

SYMBOL 	DELTAZ 0.120 0.151 0.182 0.228 0.352 10.000	PARAMETRIC VALUES BSTFOW 50.000 ORBPOW 50.000 DELTAX 0.522 ALPHAI 0.000 MACH 5.010 ELVBST 0.000 ELVORB 0.000 BETA 0.000	REFERENCE INFORMATION REFS 23.6890 SQ IN REFL 4.1930 IN REFB 6.5000 IN XMRF 4.9170 IN YMRF 0.0000 IN ZMRF 1.3900 IN SCALE 0.0055
------------	---	---	---

REFERENCE FILE

# AEDC VA 1163 MDAC BOOSTER AND ORBITER TEST DATA AT MACH NUMBER 5

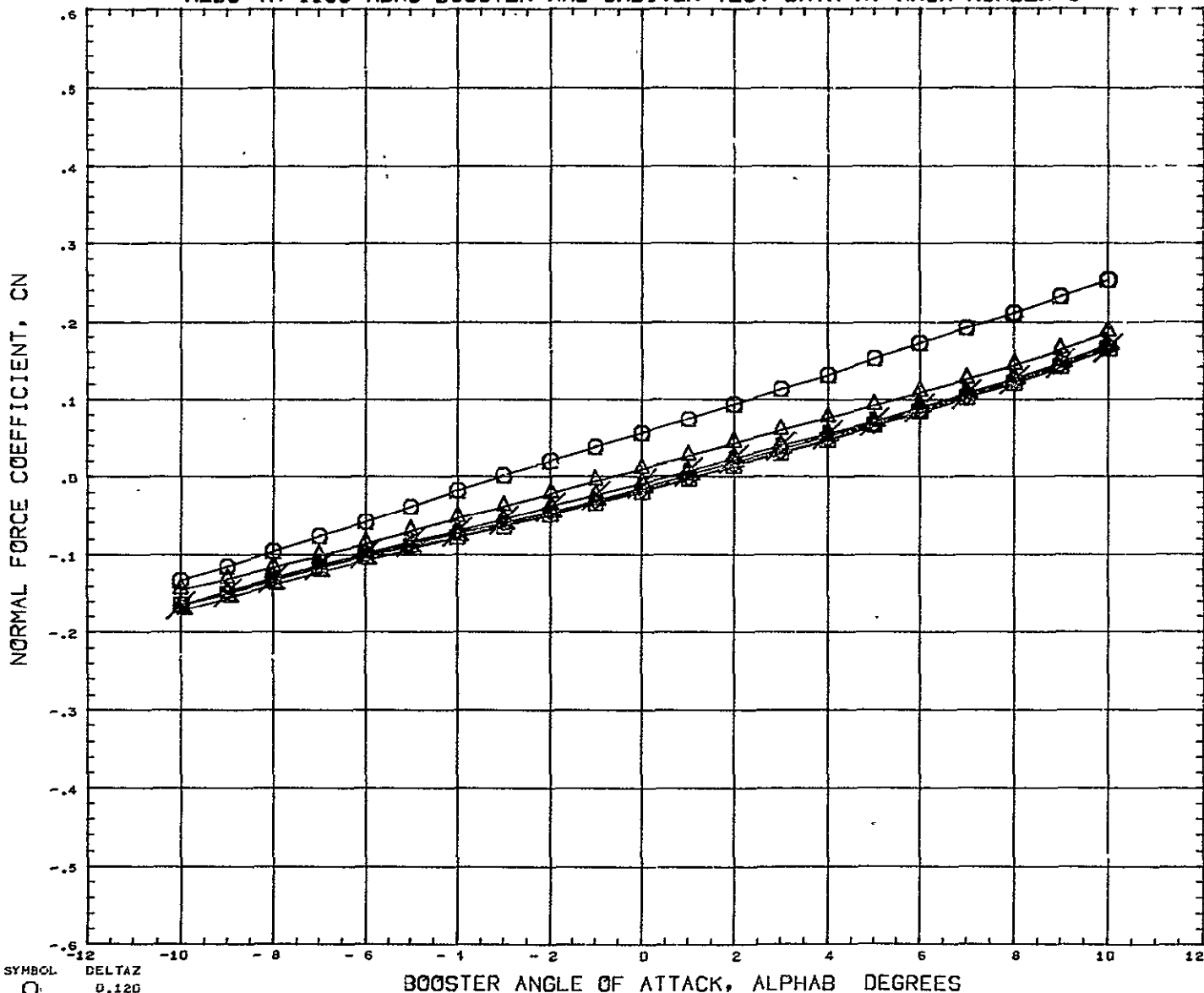

SYMBOL ○ □ △ ◇ ▽	DELTAX 0.120 0.151 0.182 0.228 0.352 10.000	PARAMETRIC VALUES BSTPOW 50.000 ORBPOW 50.000 DELTAX 0.522 ALPHAI 0.000 MACH 5.010 ELVBST 0.000 ELVORB 0.000 BETA 0.000	REFERENCE INFORMATION REFS 23.6890 SQ IN REFL 4.1930 IN REFB 6.5000 IN XMRP 4.9170 IN YMRP 0.0000 IN ZMRP 1.3900 IN SCALE 0.0055
---------------------------------	---	---	---

REFERENCE FILE



# AEDC VA 1163 MDAC BOOSTER AND ORBITER TEST DATA AT MACH NUMBER 5

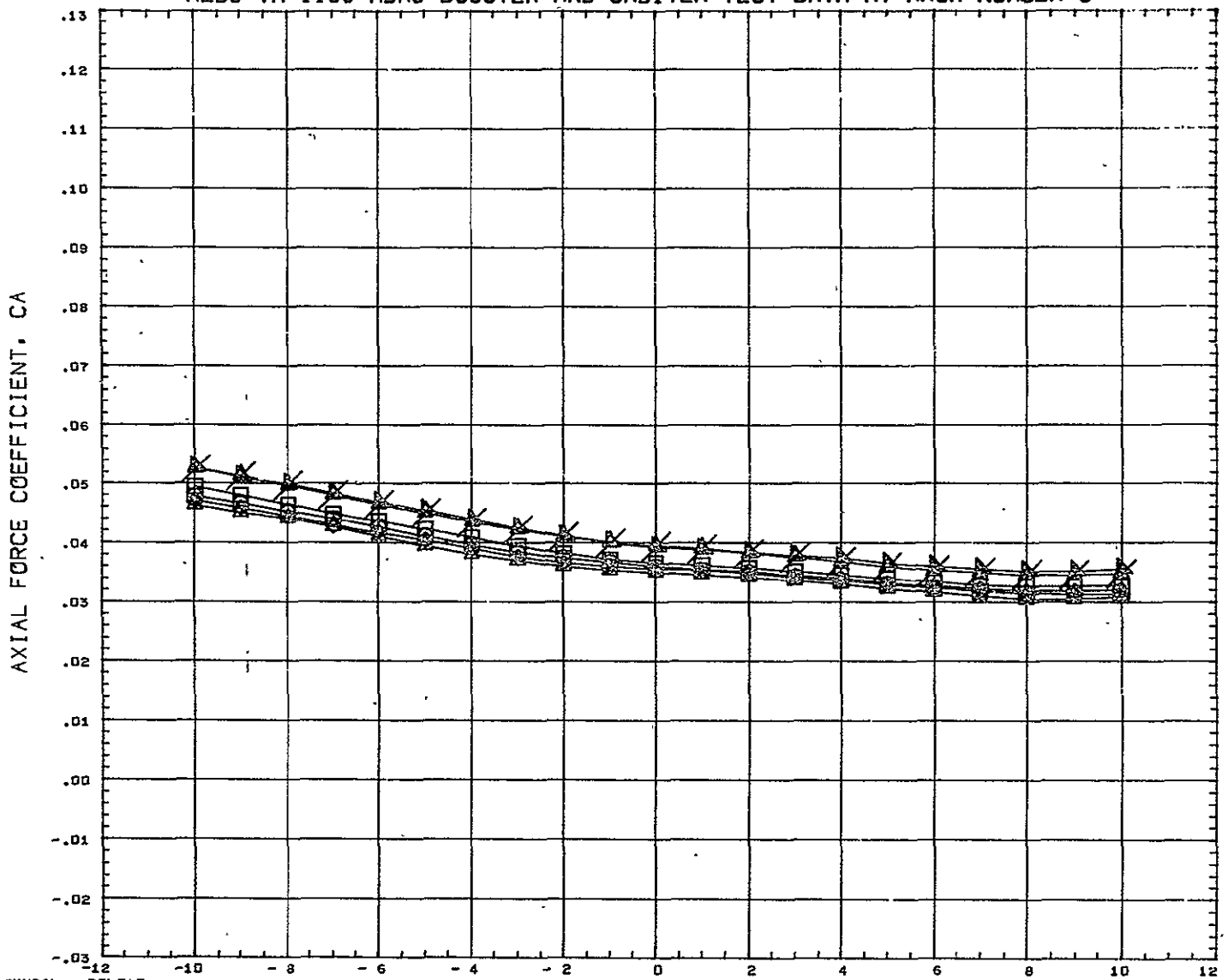

SYMBOL ○ ◇ □ △ ×	DELTA Z 0.120 0.151 0.182 0.228 0.352 10.000	PARAMETRIC VALUES BSTPOW 50.000 ORBPOW 50.000 DELTAX 0.522 ALPHAI 0.000 MACH 5.010 ELVBST 0.000 ELVORB 0.000 BETA 0.000	REFERENCE INFORMATION REFS 23.6890 SQ IN REFL 4.1930 IN REFB 6.5000 IN XMRF 4.9170 IN YMRP 0.0000 IN ZMRP 1.3960 IN SCALE 0.0055
---------------------------------	--	---	---

REFERENCE FILE 1

# AEDC VA 1163 MDAC BOOSTER AND ORBITER TEST DATA AT MACH NUMBER 5

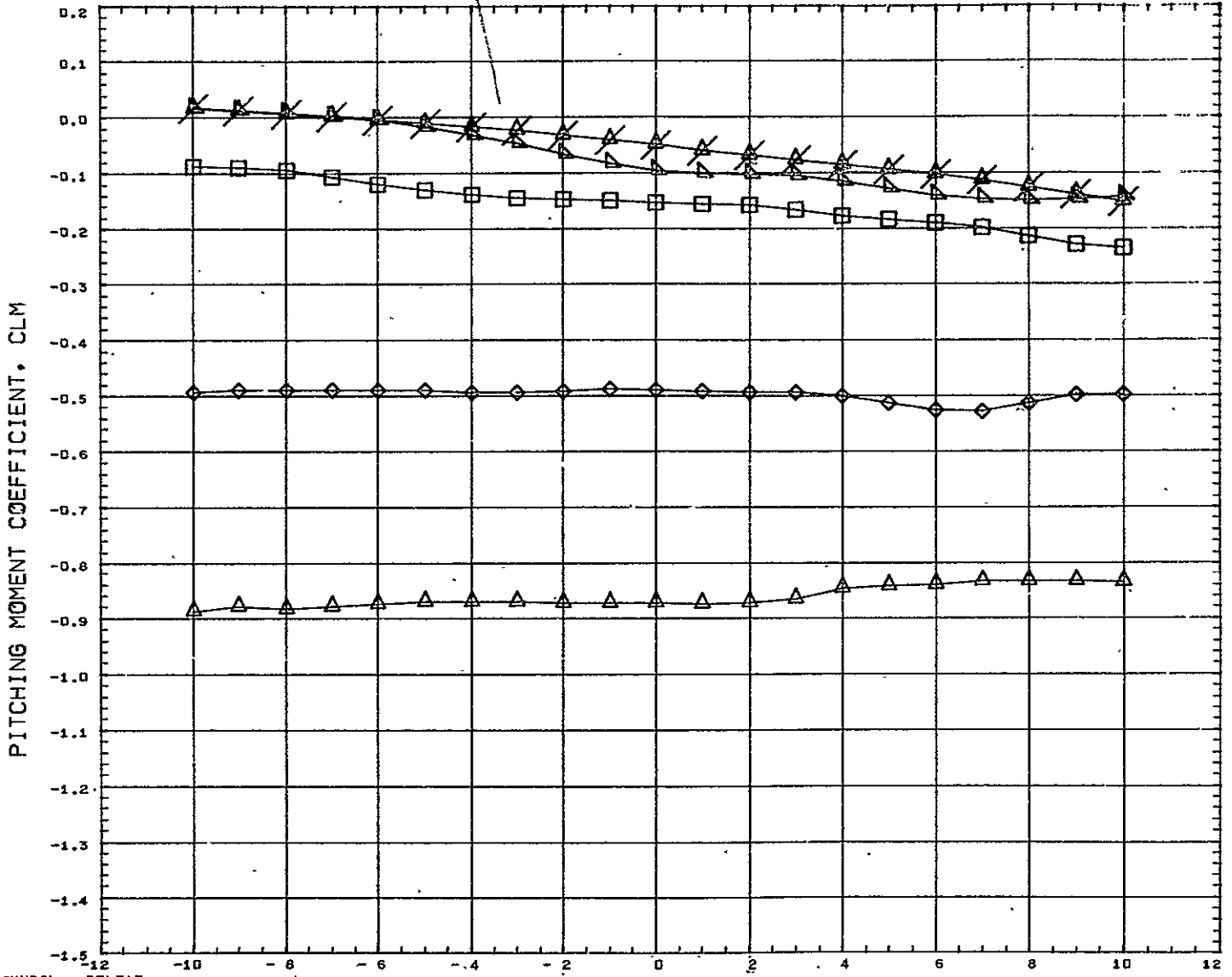

SYMBOL ◻ ◊ ◻ ▽	DELTA Z 0.151 0.182 0.228 0.352 10.000	<table border="0" style="width: 100%;"> <tr> <th colspan="4" style="text-align: left;">PARAMETRIC VALUES</th> </tr> <tr> <td>BSTPOW</td><td>50.000</td><td>ORBPOW</td><td>50.000</td> </tr> <tr> <td>DELTA X</td><td>-0.391</td><td>ALPHA I</td><td>5.000</td> </tr> <tr> <td>MACH</td><td>5.010</td><td>ELVBST</td><td>0.000</td> </tr> <tr> <td>ELVORB</td><td>0.000</td><td>BETA</td><td>0.000</td> </tr> </table>	PARAMETRIC VALUES				BSTPOW	50.000	ORBPOW	50.000	DELTA X	-0.391	ALPHA I	5.000	MACH	5.010	ELVBST	0.000	ELVORB	0.000	BETA	0.000	<table border="0" style="width: 100%;"> <tr> <th colspan="3" style="text-align: left;">REFERENCE INFORMATION</th> </tr> <tr> <td>REFS</td><td>23.6890</td><td>SQ IN</td> </tr> <tr> <td>REFL</td><td>4.1930</td><td>IN</td> </tr> <tr> <td>REFB</td><td>6.5000</td><td>IN</td> </tr> <tr> <td>XMRP</td><td>4.9170</td><td>IN</td> </tr> <tr> <td>YMRP</td><td>0.0000</td><td>IN</td> </tr> <tr> <td>ZMRP</td><td>1.3900</td><td>IN</td> </tr> <tr> <td>SCALE</td><td>0.0055</td><td></td> </tr> </table>	REFERENCE INFORMATION			REFS	23.6890	SQ IN	REFL	4.1930	IN	REFB	6.5000	IN	XMRP	4.9170	IN	YMRP	0.0000	IN	ZMRP	1.3900	IN	SCALE	0.0055	
PARAMETRIC VALUES																																															
BSTPOW	50.000	ORBPOW	50.000																																												
DELTA X	-0.391	ALPHA I	5.000																																												
MACH	5.010	ELVBST	0.000																																												
ELVORB	0.000	BETA	0.000																																												
REFERENCE INFORMATION																																															
REFS	23.6890	SQ IN																																													
REFL	4.1930	IN																																													
REFB	6.5000	IN																																													
XMRP	4.9170	IN																																													
YMRP	0.0000	IN																																													
ZMRP	1.3900	IN																																													
SCALE	0.0055																																														

REFERENCE FILE

# AEDC VA 1163 MDAC BOOSTER AND ORBITER TEST DATA AT MACH NUMBER 5

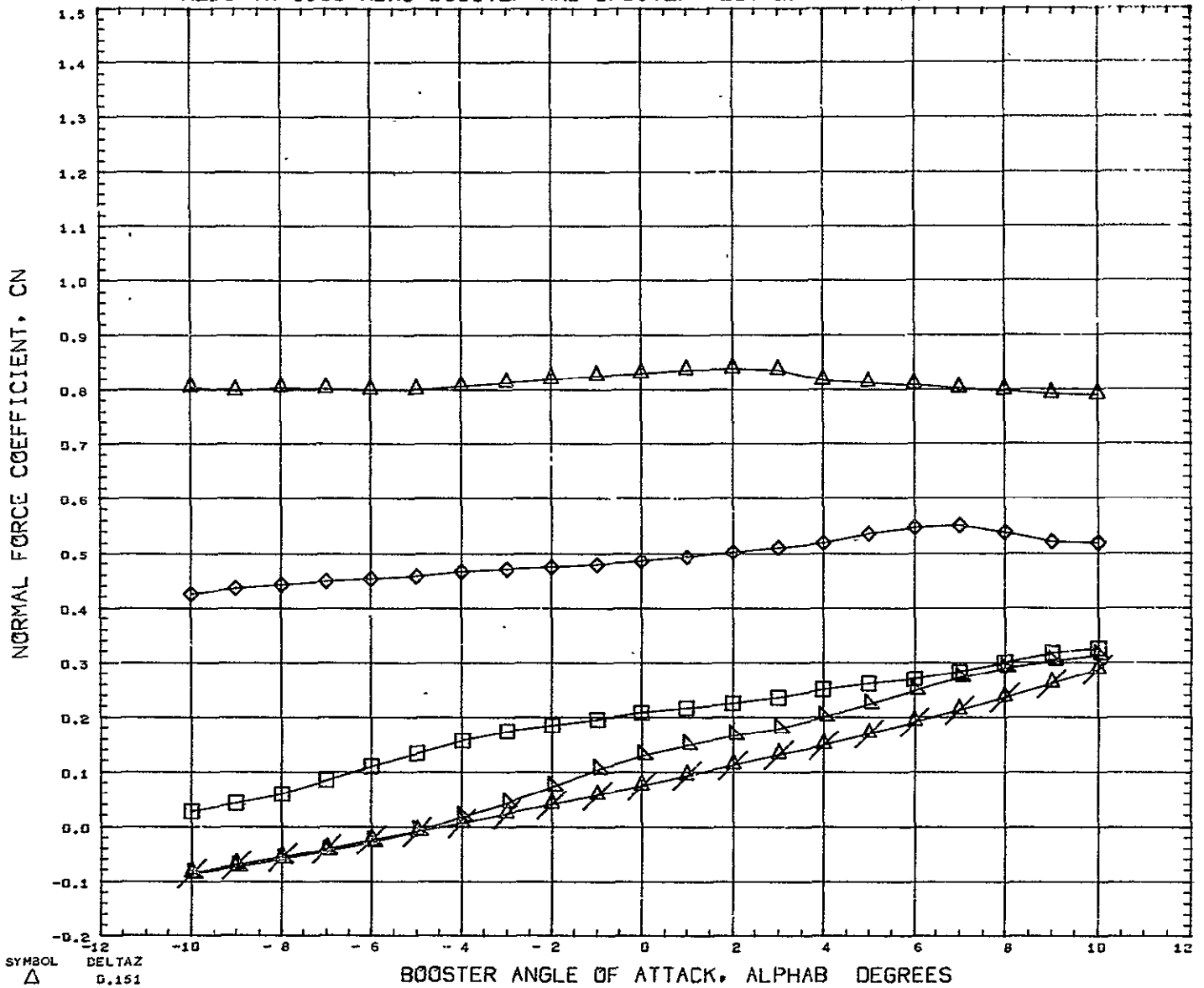

SYMBOL △ ◇ □ ×	DELTAZ 0.151 0.182 0.228 0.352 10.000	PARAMETRIC VALUES BSTFOW 50.000 ORBPOW 50.000 DELTAX - 0.391 ALPHAI 5.000 MACH 5.010 ELVBST 0.000 ELVORB 0.000 BETA 0.300	REFERENCE INFORMATION REFS 23.6890 SQ IN REFL 4.1930 IN REFB 6.5000 IN XMRP 4.9170 IN YMRP 0.0000 IN ZMRP 1.3900 IN SCALE 0.0055
----------------------------	--	---	---

REFERENCE FILE

# AEDC VA 1163 MDAC BOOSTER AND ORBITER TEST DATA AT MACH NUMBER 5

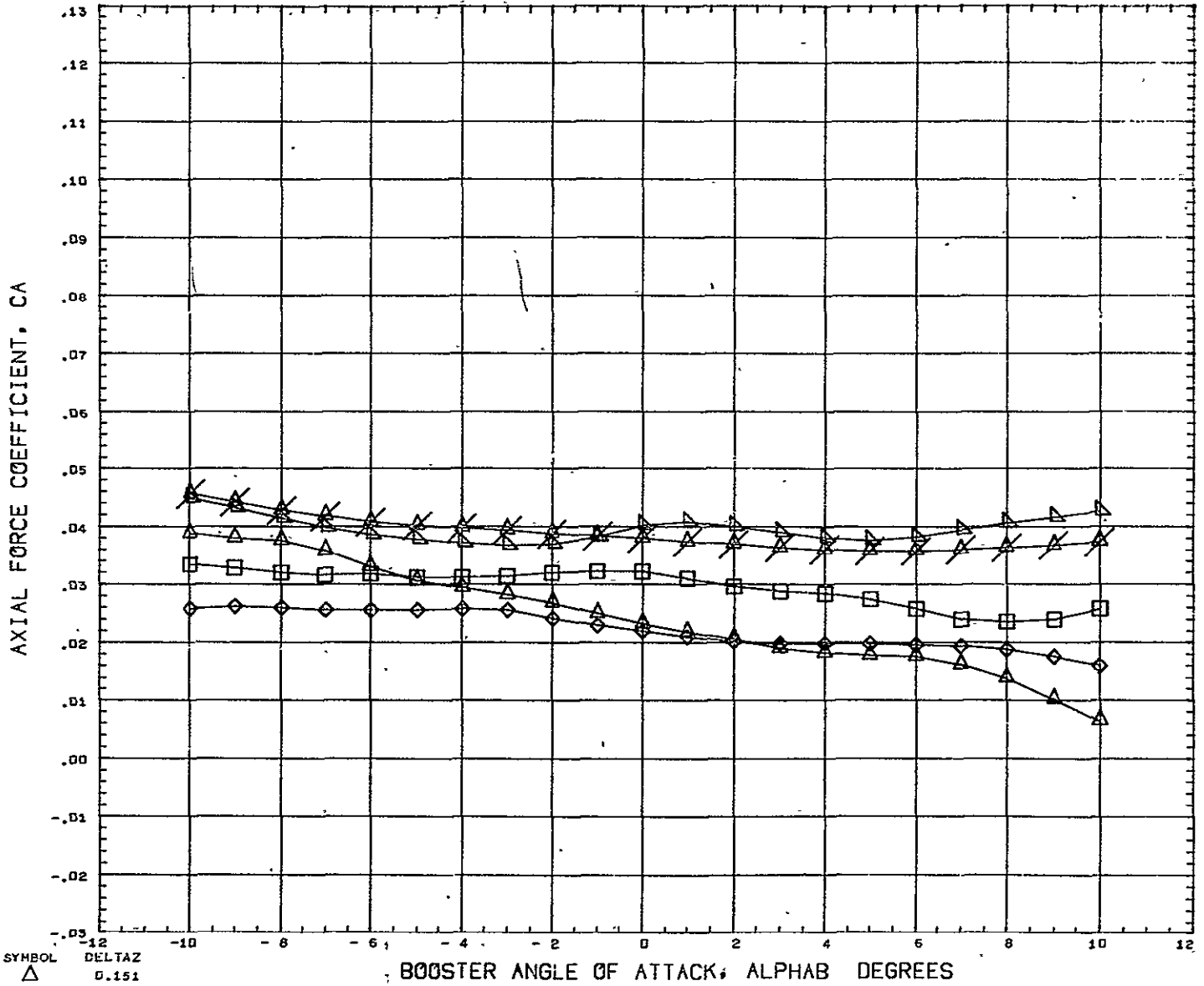

SYMBOL △ ◇ □ ▽	DELTAX 0.151 0.182 0.228 0.352 10.000	PARAMETRIC VALUES BSTPOW 50.000 ORBPOW 50.000 DELTAX - 0.391 ALPHAI 5.000 MACH 5.010 ELVBST 0.000 ELVORB 0.000 BETA 0.000	REFERENCE INFORMATION REFS 23.6890 SQ IN REFL 4.1930 IN REFB 6.5000 IN XMRP 4.9170 IN YMRP 0.0000 IN ZMRP 1.3900 IN SCALE 0.0055
----------------------------	--	---	---

REFERENCE FILE

# AEDC VA 1163 MDAC BOOSTER AND ORBITER TEST DATA AT MACH NUMBER 5

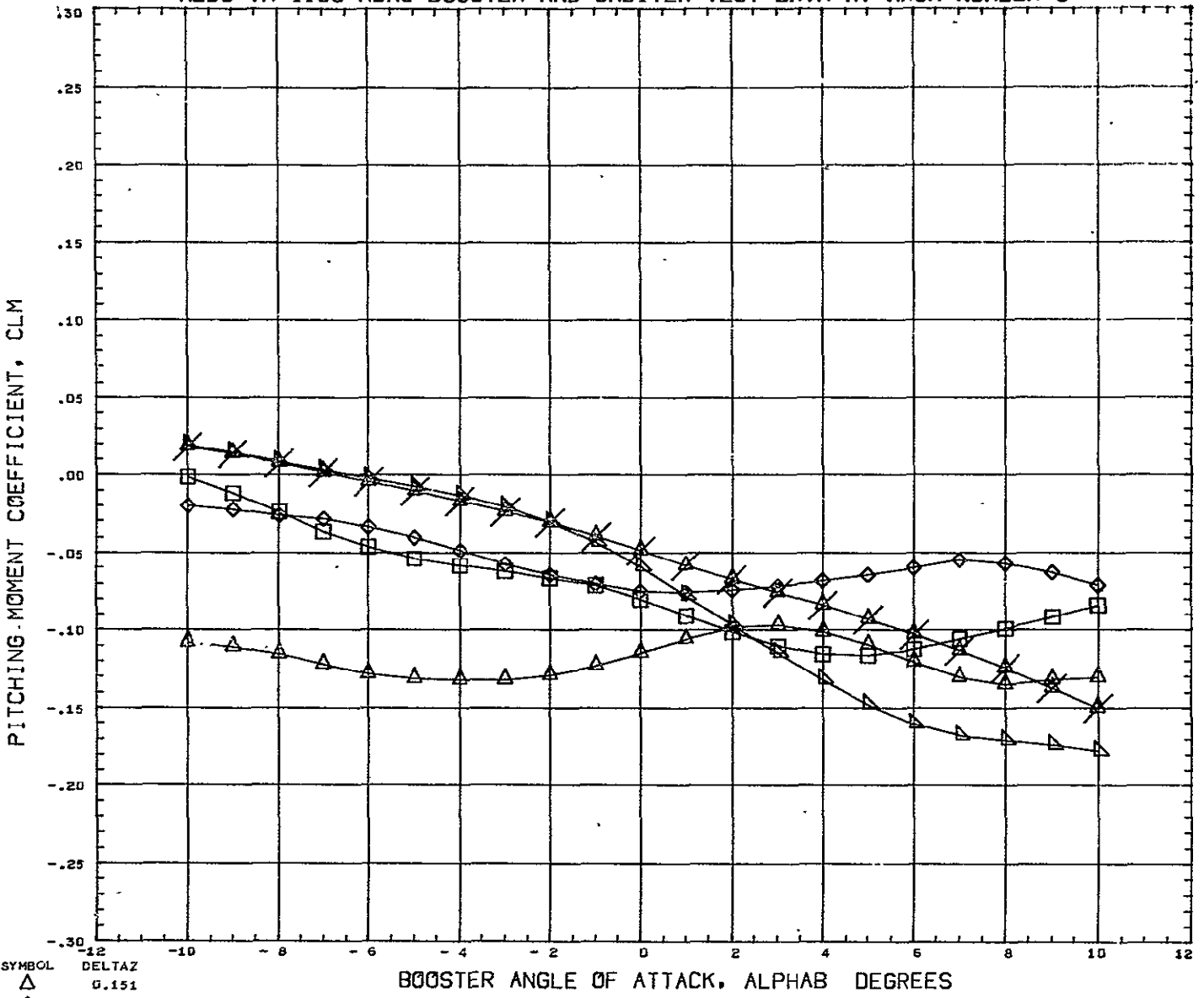

SYMBOL △ ◇ □ ○ ×	DELTAZ 0.151 0.182 0.228 0.352 10.000	<table border="0" style="width: 100%;"> <tr> <th colspan="4" style="text-align: center;">PARAMETRIC VALUES</th> </tr> <tr> <td>BSTPOW</td> <td>50.000</td> <td>ORBPOW</td> <td>50.000</td> </tr> <tr> <td>DELTA X</td> <td>0.143</td> <td>ALPHA I</td> <td>5.000</td> </tr> <tr> <td>MACH</td> <td>5.010</td> <td>ELVBST</td> <td>0.000</td> </tr> <tr> <td>ELVORB</td> <td>0.000</td> <td>BETA</td> <td>0.000</td> </tr> </table>	PARAMETRIC VALUES				BSTPOW	50.000	ORBPOW	50.000	DELTA X	0.143	ALPHA I	5.000	MACH	5.010	ELVBST	0.000	ELVORB	0.000	BETA	0.000	<table border="0" style="width: 100%;"> <tr> <th colspan="3" style="text-align: center;">REFERENCE INFORMATION</th> </tr> <tr> <td>REFS</td> <td>23.6890</td> <td>SQ IN</td> </tr> <tr> <td>REFL</td> <td>4.1930</td> <td>IN</td> </tr> <tr> <td>REFB</td> <td>6.5000</td> <td>IN</td> </tr> <tr> <td>XMRP</td> <td>4.9170</td> <td>IN</td> </tr> <tr> <td>YMRP</td> <td>0.0000</td> <td>IN</td> </tr> <tr> <td>ZMRP</td> <td>1.3900</td> <td>IN</td> </tr> <tr> <td>SCALE</td> <td>0.0055</td> <td></td> </tr> </table>	REFERENCE INFORMATION			REFS	23.6890	SQ IN	REFL	4.1930	IN	REFB	6.5000	IN	XMRP	4.9170	IN	YMRP	0.0000	IN	ZMRP	1.3900	IN	SCALE	0.0055	
PARAMETRIC VALUES																																															
BSTPOW	50.000	ORBPOW	50.000																																												
DELTA X	0.143	ALPHA I	5.000																																												
MACH	5.010	ELVBST	0.000																																												
ELVORB	0.000	BETA	0.000																																												
REFERENCE INFORMATION																																															
REFS	23.6890	SQ IN																																													
REFL	4.1930	IN																																													
REFB	6.5000	IN																																													
XMRP	4.9170	IN																																													
YMRP	0.0000	IN																																													
ZMRP	1.3900	IN																																													
SCALE	0.0055																																														

REFERENCE FILE

# AEDC VA 1163 MDAC BOOSTER AND ORBITER TEST DATA AT MACH NUMBER 5

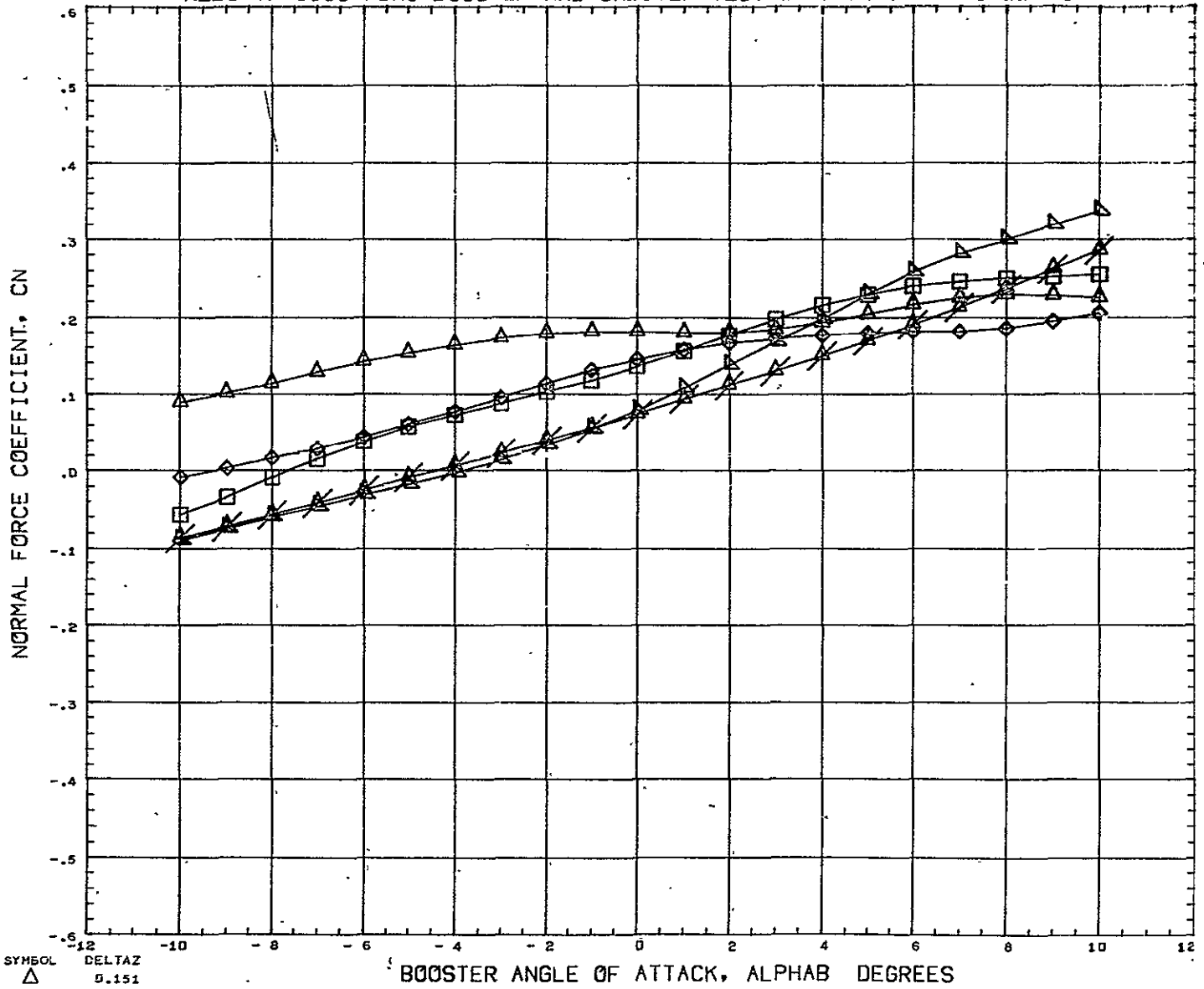

SYMBOL △ ◇ □ ○ ×	DELTAZ 0.151 0.102 0.228 0.352 10.000	PARAMETRIC VALUES BSTFOW 50.000 ORBPOW 50.000 DELTAX - 0.143 ALPHAI 5.000 MACH 5.010 ELVBST 0.000 ELVORB 0.000 BETA 0.000	REFERENCE INFORMATION REFS 23.6890 SQ IN REFL 4.1930 IN REFB 6.5000 IN XMRF 4.9170 IN YMRP 0.0000 IN ZMRP 1.3900 IN SCALE 0.0055
---------------------------------	--	---	---

REFERENCE FILE

# AEDC VA 1163 MDAC BOOSTER AND ORBITER TEST DATA AT MACH NUMBER 5

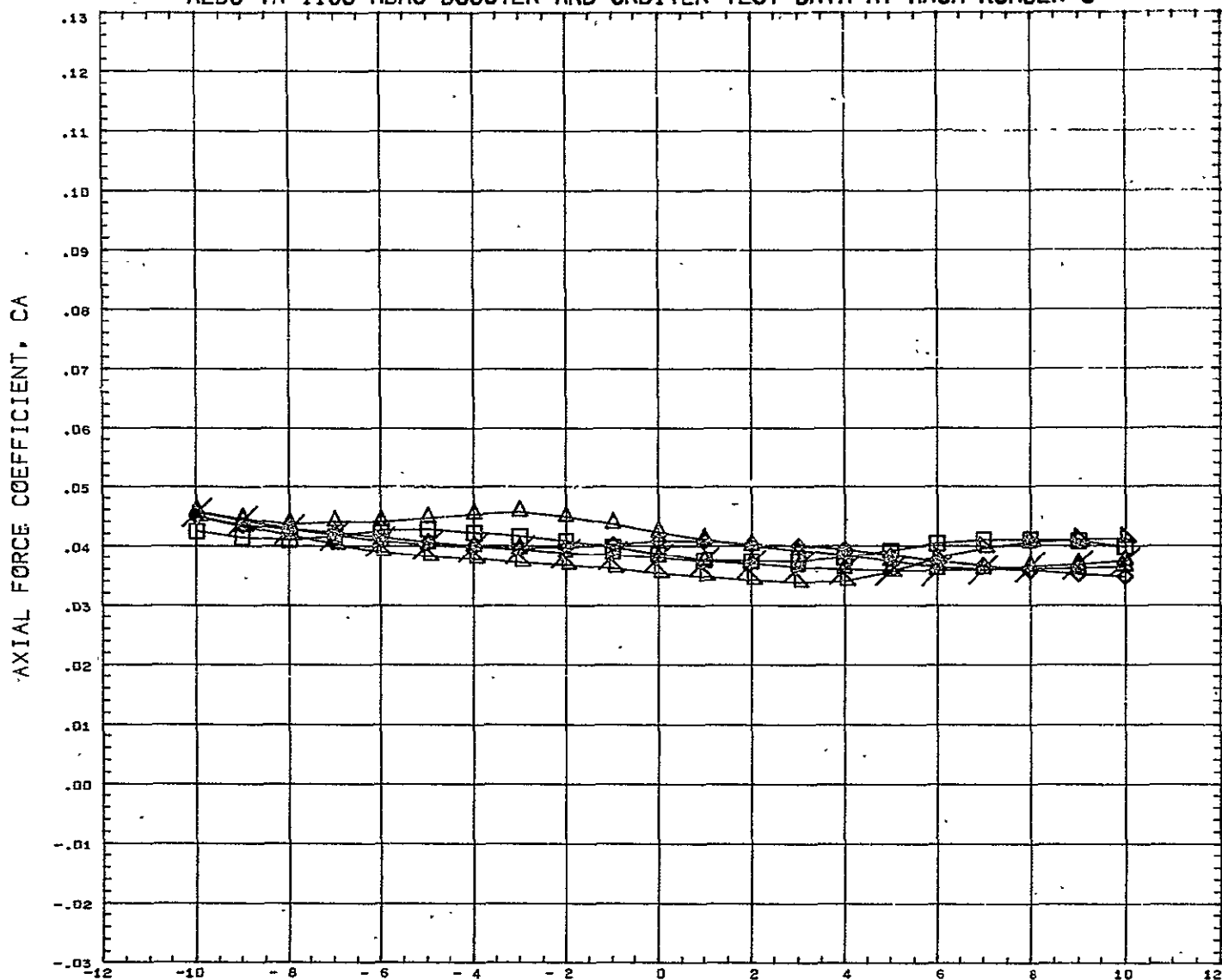

SYMBOL △ ◇ □ ⊗	DELTAZ 0.151 0.102 0.228 0.352 10.000	PARAMETRIC VALUES BSTPOW 50.000 ORBPOW 50.000 DELTAX 0.143 ALPHAI 5.000 MACH 5.010 ELVBST 0.000 ELVORB 0.000 BETA 0.000	REFERENCE INFORMATION REFS 23.6890 SQ IN REFL 4.1930 IN REFB 6.5000 IN XMRF 4.9175 IN YMRF 0.0000 IN ZMRF 1.3900 IN SCALE 0.0055
----------------------------	--	---	---

REFERENCE FILE

# AEDC VA 1163 MDAC BOOSTER AND ORBITER TEST DATA AT MACH NUMBER 5

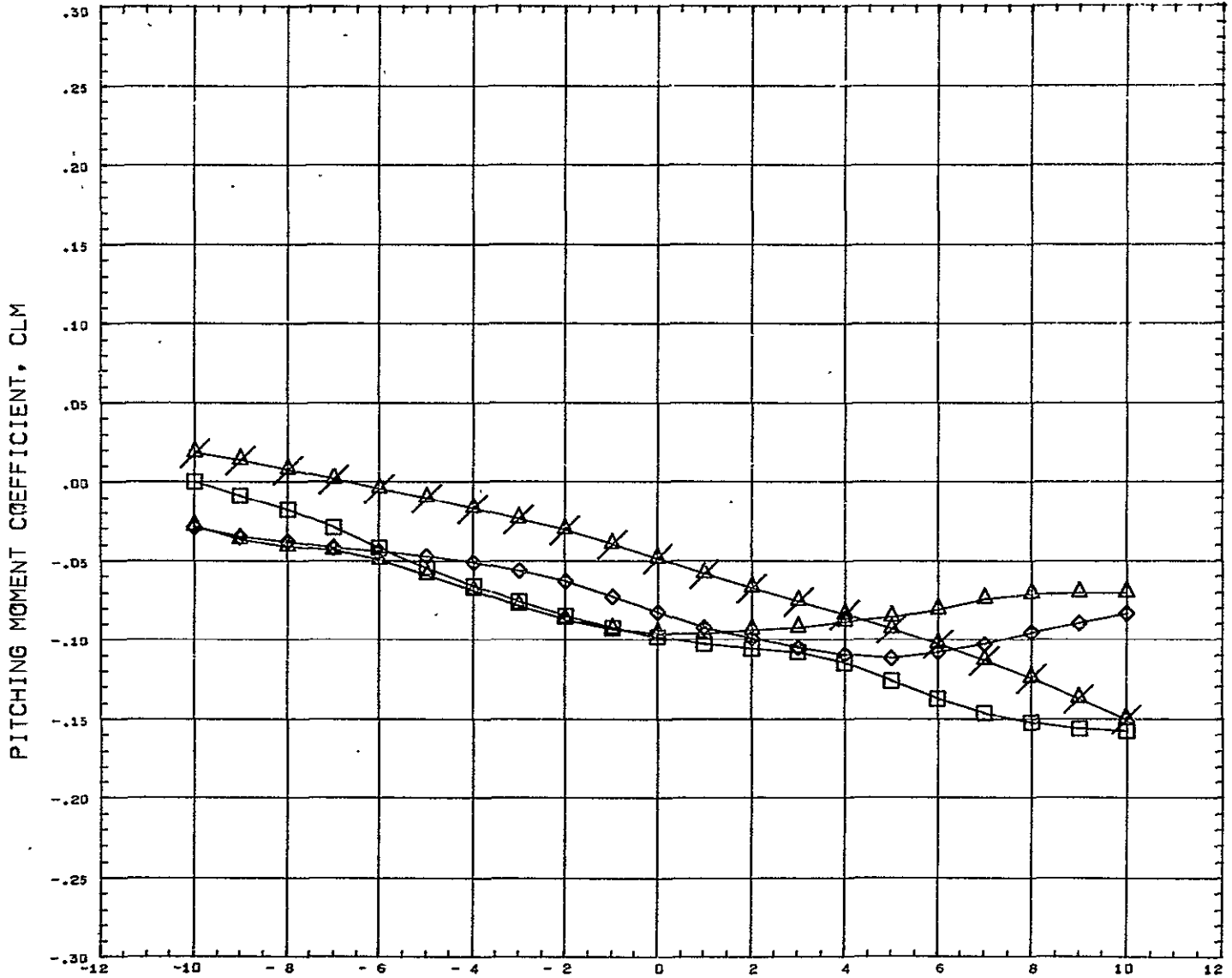

SYMBOL △ ◇ □ ×	DELTAX 0.151 0.182 0.228 10.000	PARAMETRIC VALUES BSTFOW 50.000    ORBPOW 50.000 DELTAX - 0.019    ALPHAI 5.000 MACH 5.010    ELVBST 0.000 ELVORB 0.000    BETA 0.000	REFERENCE INFORMATION REFS 23.6890    SQ IN REFL 4.1930    IN REFB 6.5000    IN XHRF 4.9170    IN YHRF 0.0000    IN ZHRF 1.3900    IN SCALE 0.0055
----------------------------	---	---	---

REFERENCE FILE



# AEDC VA 1163 MDAC BOOSTER AND ORBITER TEST DATA AT MACH NUMBER 5

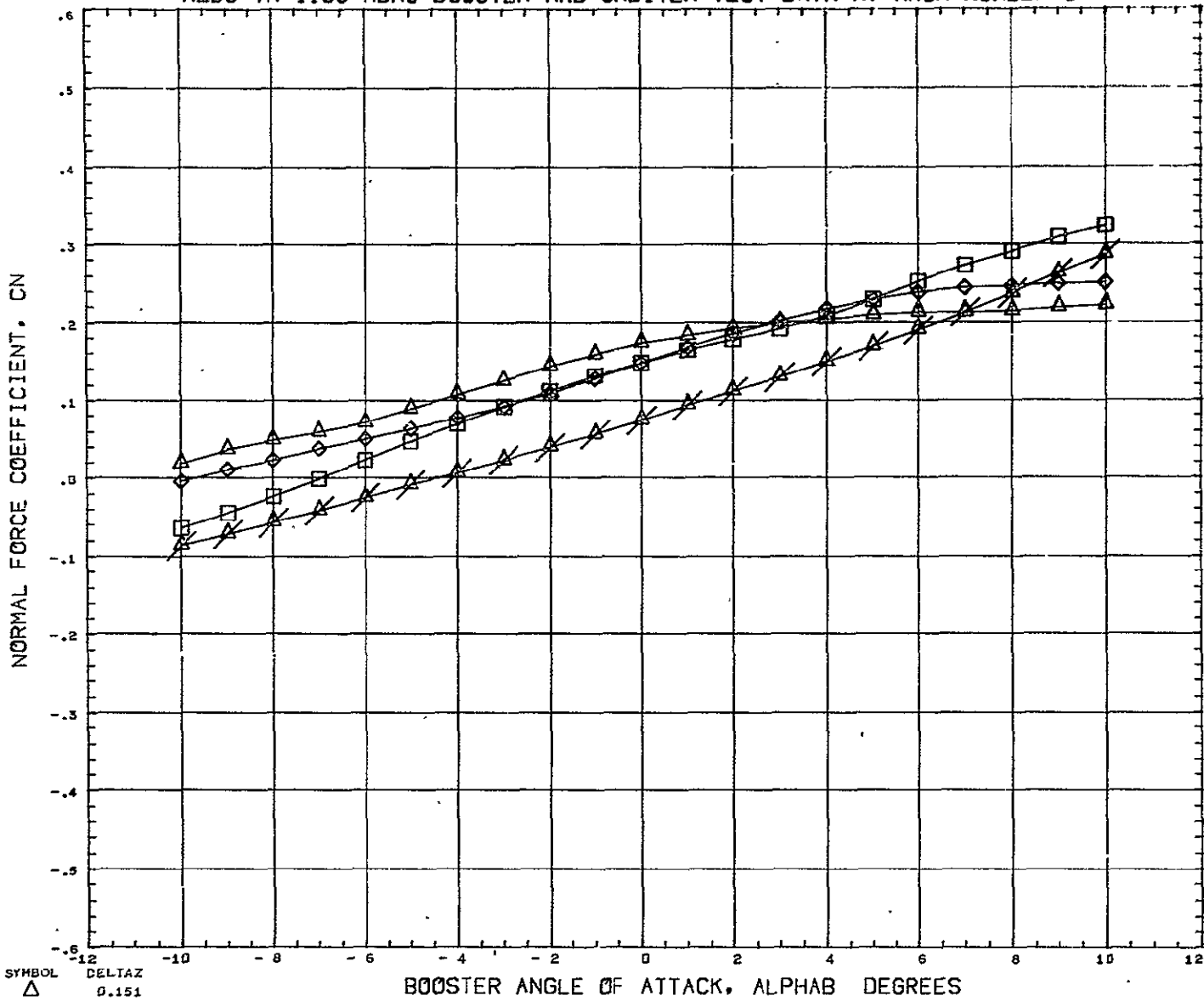

SYMBOL    DELTA Z  
 △        0.151  
 ◇        0.182  
 □        0.228  
 ×        10.000

PARAMETRIC VALUES  
 BSTPOW    50.000    ORBPOW    50.000  
 DELTAX   - 0.019    ALPHA1    5.000  
 MACH       5.010    ELVBST    0.000  
 ELVORB    0.000    BETA       0.000

REFERENCE INFORMATION  
 REFS       23.6890    SQ IN  
 REFL       4.1930    IN  
 REFB       6.5000    IN  
 XMRF       4.9100    IN  
 YMRF       0.0000    IN  
 ZMRF       1.3900    IN  
 SCALE      0.0055

REFERENCE FILE

# AEDC VA 1163 MDAC BOOSTER AND ORBITER TEST DATA AT MACH NUMBER 5

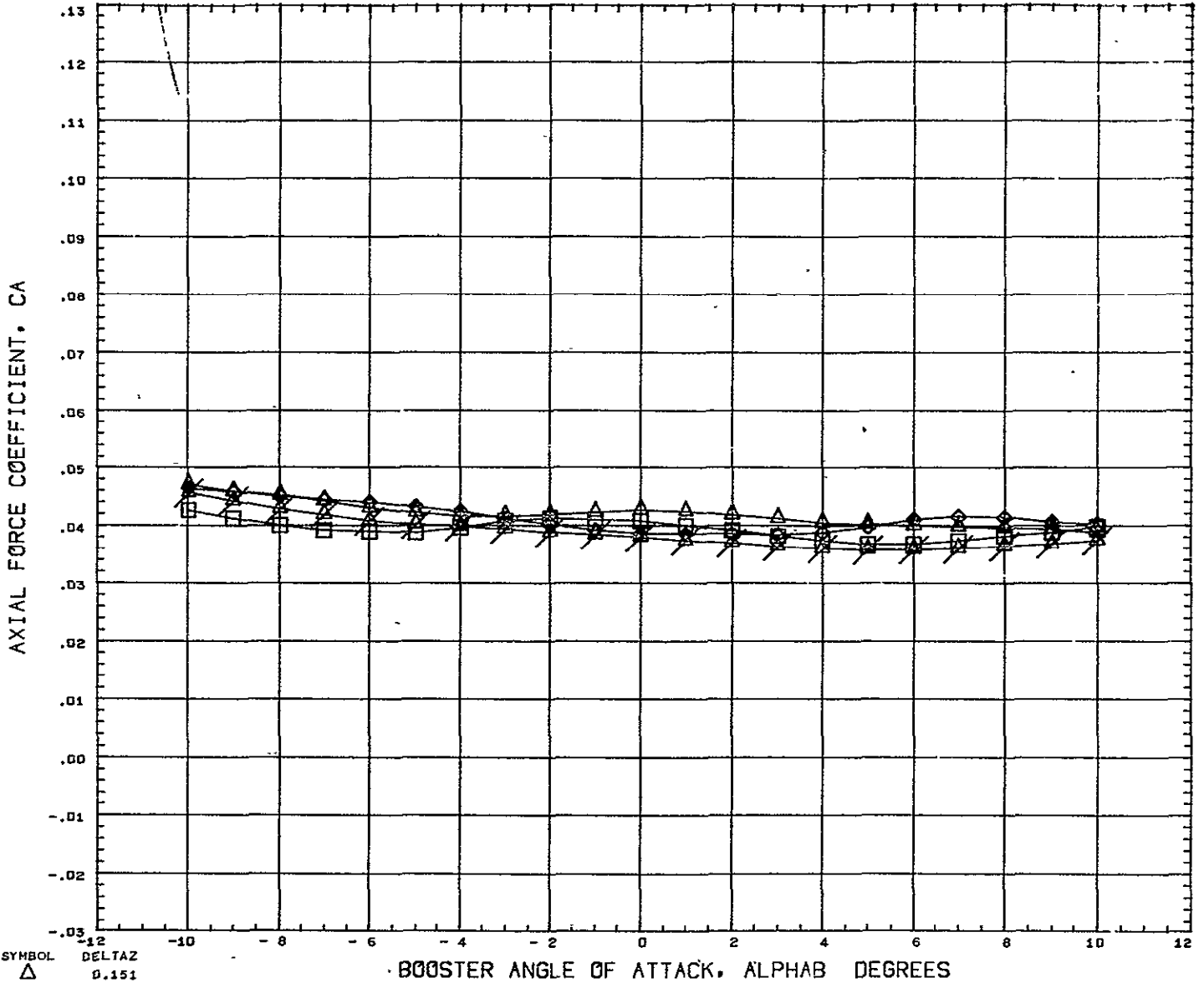

SYMBOL △ ◇ □ ×	DELTA Z 0.151 0.182 0.228 10.000	<table border="0" style="width: 100%;"> <tr> <th colspan="4" style="text-align: center;">PARAMETRIC VALUES</th> </tr> <tr> <td>BSTPOW</td><td>50.000</td><td>ORBPOW</td><td>50.000</td></tr> <tr> <td>DELTA X</td><td>0.019</td><td>ALPHA I</td><td>5.000</td></tr> <tr> <td>MACH</td><td>5.010</td><td>ELVST</td><td>0.000</td></tr> <tr> <td>ELVORB</td><td>0.000</td><td>BETA</td><td>0.000</td></tr> </table>	PARAMETRIC VALUES				BSTPOW	50.000	ORBPOW	50.000	DELTA X	0.019	ALPHA I	5.000	MACH	5.010	ELVST	0.000	ELVORB	0.000	BETA	0.000	<table border="0" style="width: 100%;"> <tr> <th colspan="3" style="text-align: center;">REFERENCE INFORMATION</th> </tr> <tr> <td>REFS</td><td>23.6890</td><td>SQ IN</td></tr> <tr> <td>REFL</td><td>4.1930</td><td>IN</td></tr> <tr> <td>REFB</td><td>6.5000</td><td>IN</td></tr> <tr> <td>XMRP</td><td>4.9170</td><td>IN</td></tr> <tr> <td>YMRP</td><td>0.0000</td><td>IN</td></tr> <tr> <td>ZMRP</td><td>1.3900</td><td>IN</td></tr> <tr> <td>SCALE</td><td>0.0055</td><td></td></tr> </table>	REFERENCE INFORMATION			REFS	23.6890	SQ IN	REFL	4.1930	IN	REFB	6.5000	IN	XMRP	4.9170	IN	YMRP	0.0000	IN	ZMRP	1.3900	IN	SCALE	0.0055	
PARAMETRIC VALUES																																															
BSTPOW	50.000	ORBPOW	50.000																																												
DELTA X	0.019	ALPHA I	5.000																																												
MACH	5.010	ELVST	0.000																																												
ELVORB	0.000	BETA	0.000																																												
REFERENCE INFORMATION																																															
REFS	23.6890	SQ IN																																													
REFL	4.1930	IN																																													
REFB	6.5000	IN																																													
XMRP	4.9170	IN																																													
YMRP	0.0000	IN																																													
ZMRP	1.3900	IN																																													
SCALE	0.0055																																														
REFERENCE FILE																																															

# AEDC VA 1163 MDAC BOOSTER AND ORBITER TEST DATA AT MACH NUMBER 5

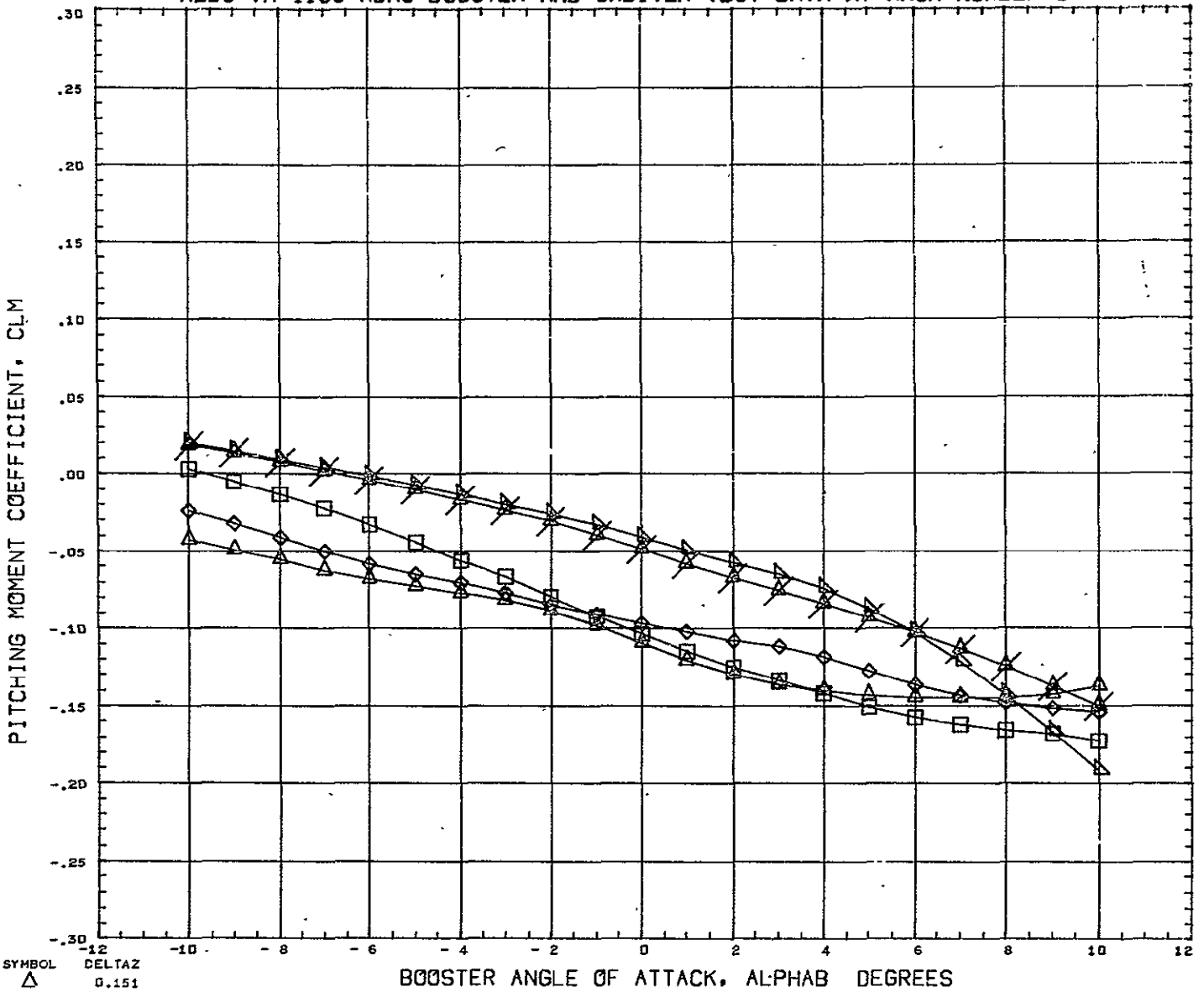

SYMBOL △ ◇ □ × ▽	DELTAZ 0.151 0.182 0.228 0.352 10.000	<table border="0" style="width: 100%;"> <tr> <th colspan="4" style="text-align: left; padding-left: 20px;">PARAMETRIC VALUES</th> </tr> <tr> <td style="padding-right: 10px;">BSTFOW</td> <td style="padding-right: 10px;">50.000</td> <td style="padding-right: 10px;">ORBPOW</td> <td>50.000</td> </tr> <tr> <td style="padding-right: 10px;">DELTA X</td> <td style="padding-right: 10px;">0.104</td> <td style="padding-right: 10px;">ALPHA I</td> <td>5.000</td> </tr> <tr> <td style="padding-right: 10px;">MACH</td> <td style="padding-right: 10px;">5.010</td> <td style="padding-right: 10px;">ELVBST</td> <td>0.000</td> </tr> <tr> <td style="padding-right: 10px;">ELVORB</td> <td style="padding-right: 10px;">0.000</td> <td style="padding-right: 10px;">BETA</td> <td>0.000</td> </tr> </table>	PARAMETRIC VALUES				BSTFOW	50.000	ORBPOW	50.000	DELTA X	0.104	ALPHA I	5.000	MACH	5.010	ELVBST	0.000	ELVORB	0.000	BETA	0.000	<table border="0" style="width: 100%;"> <tr> <th colspan="3" style="text-align: left; padding-left: 20px;">REFERENCE INFORMATION</th> </tr> <tr> <td style="padding-right: 10px;">REFS</td> <td style="padding-right: 10px;">23.6890</td> <td>SQ IN</td> </tr> <tr> <td style="padding-right: 10px;">REFL</td> <td style="padding-right: 10px;">4.1930</td> <td>IN</td> </tr> <tr> <td style="padding-right: 10px;">REFB</td> <td style="padding-right: 10px;">6.5000</td> <td>IN</td> </tr> <tr> <td style="padding-right: 10px;">XMRP</td> <td style="padding-right: 10px;">4.9170</td> <td>IN</td> </tr> <tr> <td style="padding-right: 10px;">YMRP</td> <td style="padding-right: 10px;">0.0000</td> <td>IN</td> </tr> <tr> <td style="padding-right: 10px;">ZMRP</td> <td style="padding-right: 10px;">1.3900</td> <td>IN</td> </tr> <tr> <td style="padding-right: 10px;">SCALE</td> <td style="padding-right: 10px;">0.0055</td> <td></td> </tr> </table>	REFERENCE INFORMATION			REFS	23.6890	SQ IN	REFL	4.1930	IN	REFB	6.5000	IN	XMRP	4.9170	IN	YMRP	0.0000	IN	ZMRP	1.3900	IN	SCALE	0.0055	
PARAMETRIC VALUES																																															
BSTFOW	50.000	ORBPOW	50.000																																												
DELTA X	0.104	ALPHA I	5.000																																												
MACH	5.010	ELVBST	0.000																																												
ELVORB	0.000	BETA	0.000																																												
REFERENCE INFORMATION																																															
REFS	23.6890	SQ IN																																													
REFL	4.1930	IN																																													
REFB	6.5000	IN																																													
XMRP	4.9170	IN																																													
YMRP	0.0000	IN																																													
ZMRP	1.3900	IN																																													
SCALE	0.0055																																														

REFERENCE FILE

# AEDC VA 1163 MDAC BOOSTER AND ORBITER TEST DATA AT MACH NUMBER 5

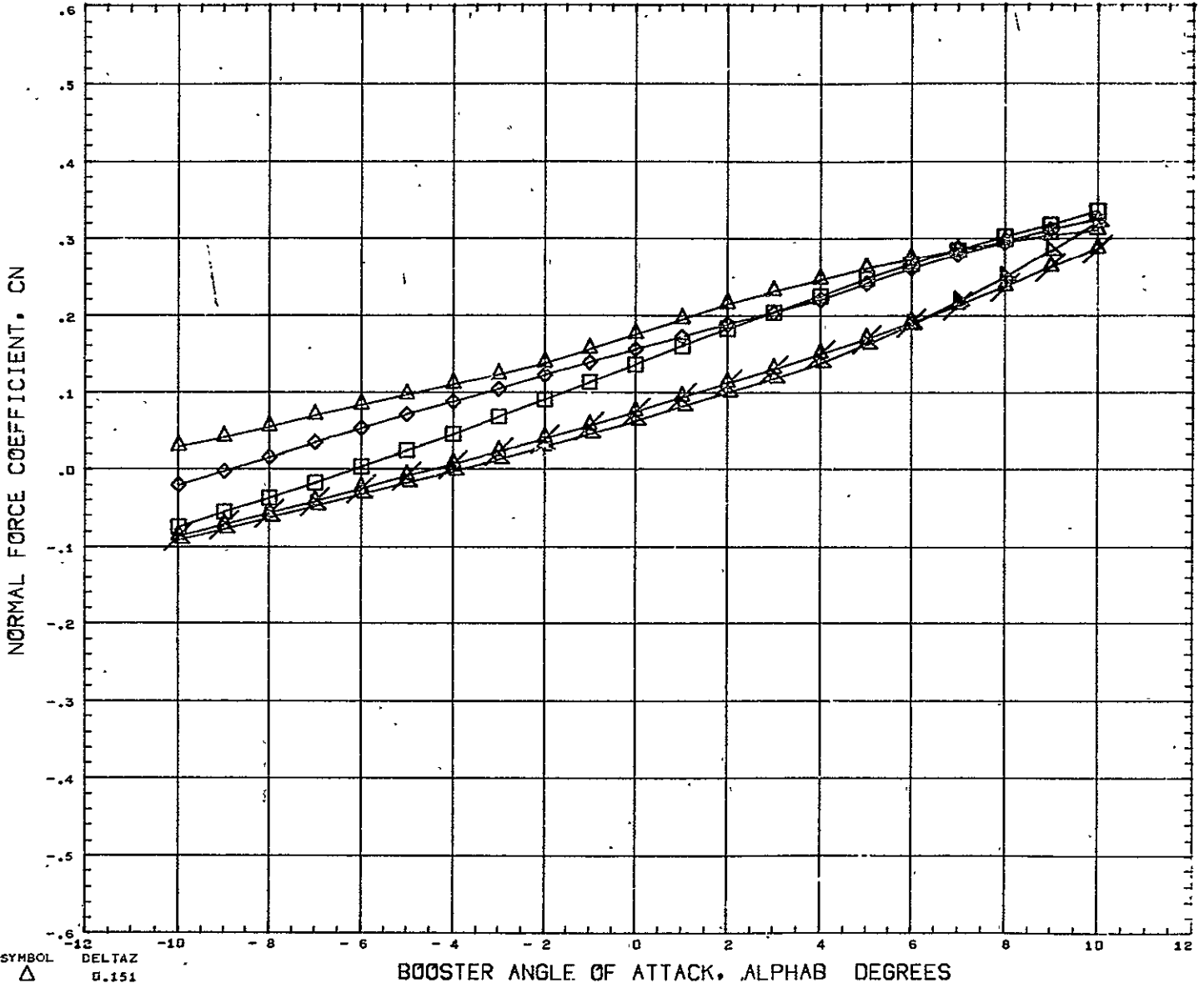

SYMBOL △ ◇ □ ○ ×	DELTAX 0.151 0.182 0.228 0.352 10.000	PARAMETRIC VALUES BSTPOW 50.000 ORBPOW 50.000 DELTAX 0.104 ALPHAI 5.000 MACH 5.010 ELVBST 0.000 ELVORB 0.000 BETA 0.000	REFERENCE INFORMATION REFS 23.6890 SQ IN REFL 4.1930 IN REFB 6.5000 IN XNRF 4.9170 IN YMRP 0.0000 IN ZHRP 1.3900 IN SCALE 0.6055
---------------------------------	--	---	---

REFERENCE FILE

# AEDC VA 1163 MDAC BOOSTER AND ORBITER TEST DATA AT MACH NUMBER 5

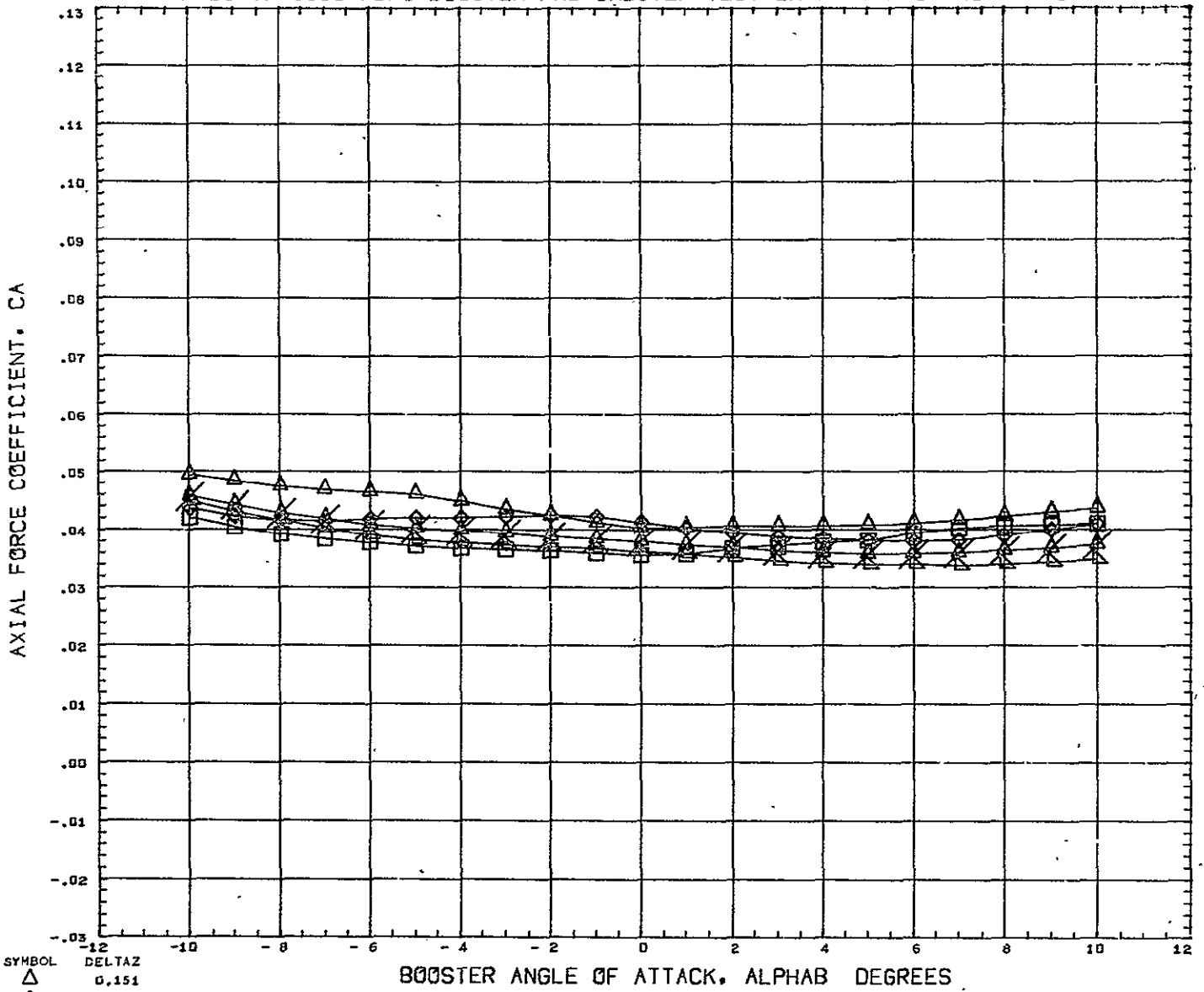

SYMBOL	DELTA Z	PARAMETRIC VALUES				REFERENCE INFORMATION	
△	0.151						
◇	0.182						
□	0.228	∂STPOW	50.000	ORBPOW	50.000	REFS	23.6890 SQ IN
◇	0.352	DELTA X	0.104	ALPHA1	5.000	REFL	4.1930 IN
△	10.000	MACH	5.010	ELVBST	0.000	REFB	6.5000 IN
		ELVORB	0.000	BETA	0.000	XMRP	4.9170 IN
						YMRP	0.0000 IN
						ZMRP	1.3900 IN
						SCALE	0.0055

REFERENCE FILE

AEDC VA 1163 MDAC BOOSTER AND ORBITER TEST DATA AT MACH NUMBER 5

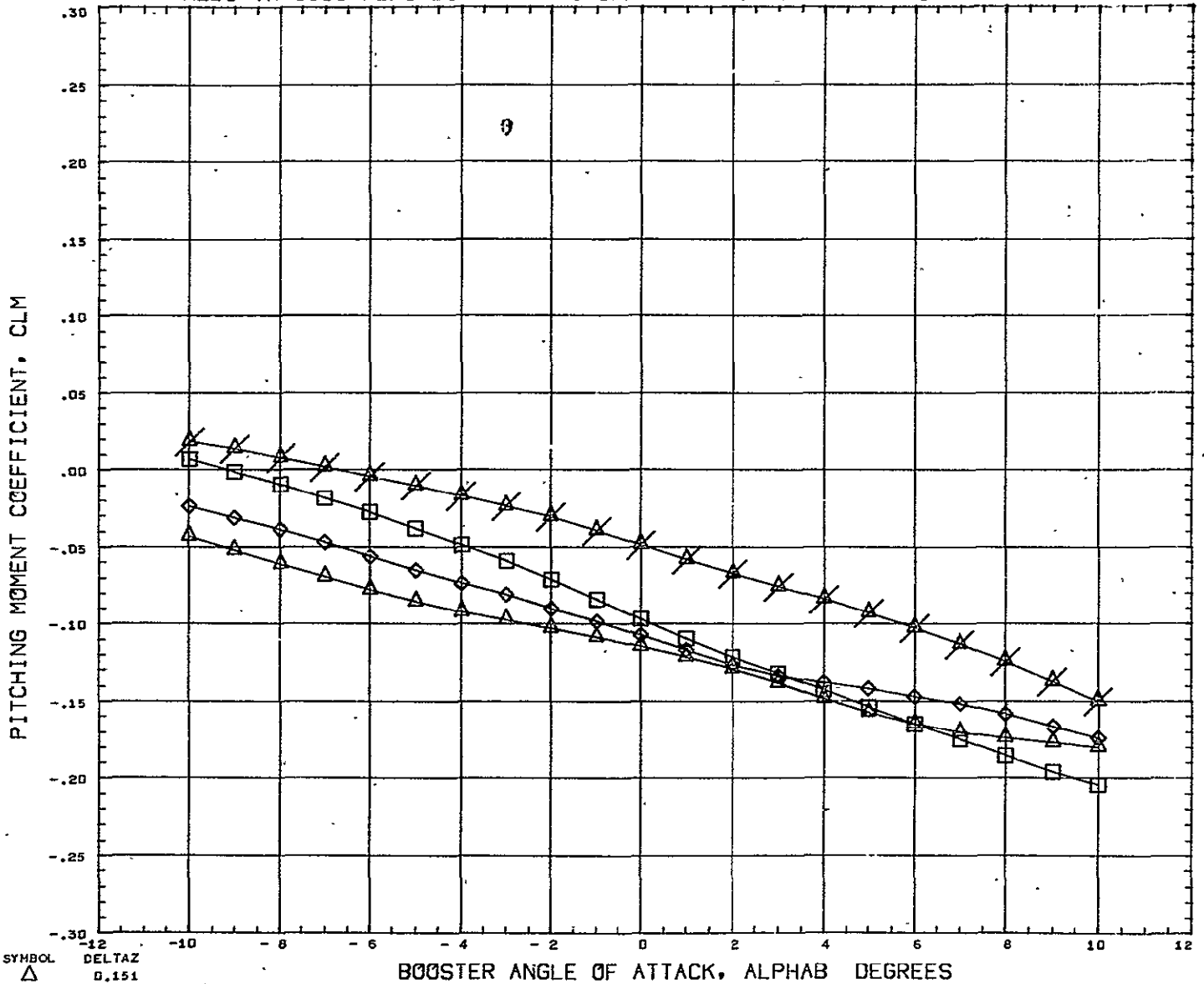

SYMBOL	DELTA Z	PARAMETRIC VALUES				REFERENCE INFORMATION		
△	0.151	BSTFOW	50.000	ORBPOW	50.000	REFS	23.6890	SQ IN
◇	0.182	DELTA X	0.166	ALPHA I	5.000	REFL	4.1930	IN
□	0.228	MACH	5.010	ELVBST	0.000	REFB	6.5000	IN
×	10.000	ELVORB	0.000	BETA	0.000	XMRP	4.9170	IN
						YMRP	0.6000	IN
						ZMRP	1.3900	IN
						SCALE	0.0055	

REFERENCE FILE

# AEDC VA 1163 MDAC BOOSTER AND ORBITER TEST DATA AT MACH NUMBER 5

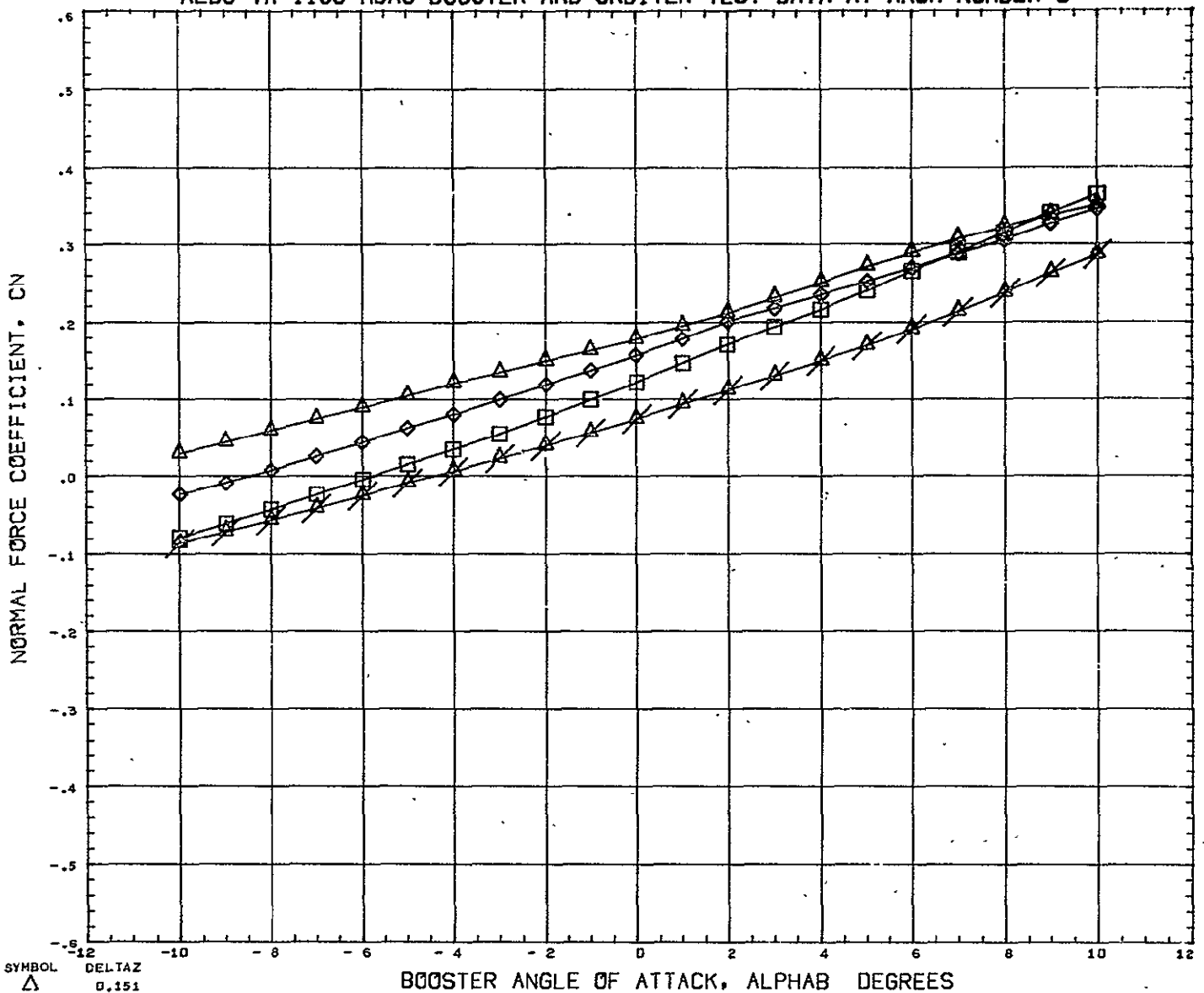

SYMBOL

- △
- ◇
- 
- ⊗

DELTA Z  
0.151  
0.182  
0.228  
10.000

PARAMETRIC VALUES

BSTFCW	50.000	ORBFOW	50.000
DELTA X	0.166	ALPHA I	5.000
MACH	5.010	ELVBST	0.000
ELVORB	0.000	BETA	0.000

REFERENCE FILE

REFERENCE INFORMATION

REFS	23.6890	SQ	IN
REFL	4.1930	IN	
REFB	6.5500	IN	
XMRP	4.9170	IN	
YMRP	0.0000	IN	
ZMRP	1.3900	IN	
SCALE	0.0055		

# AEDC VA 1163 MDAC BOOSTER AND ORBITER TEST DATA AT MACH NUMBER 5

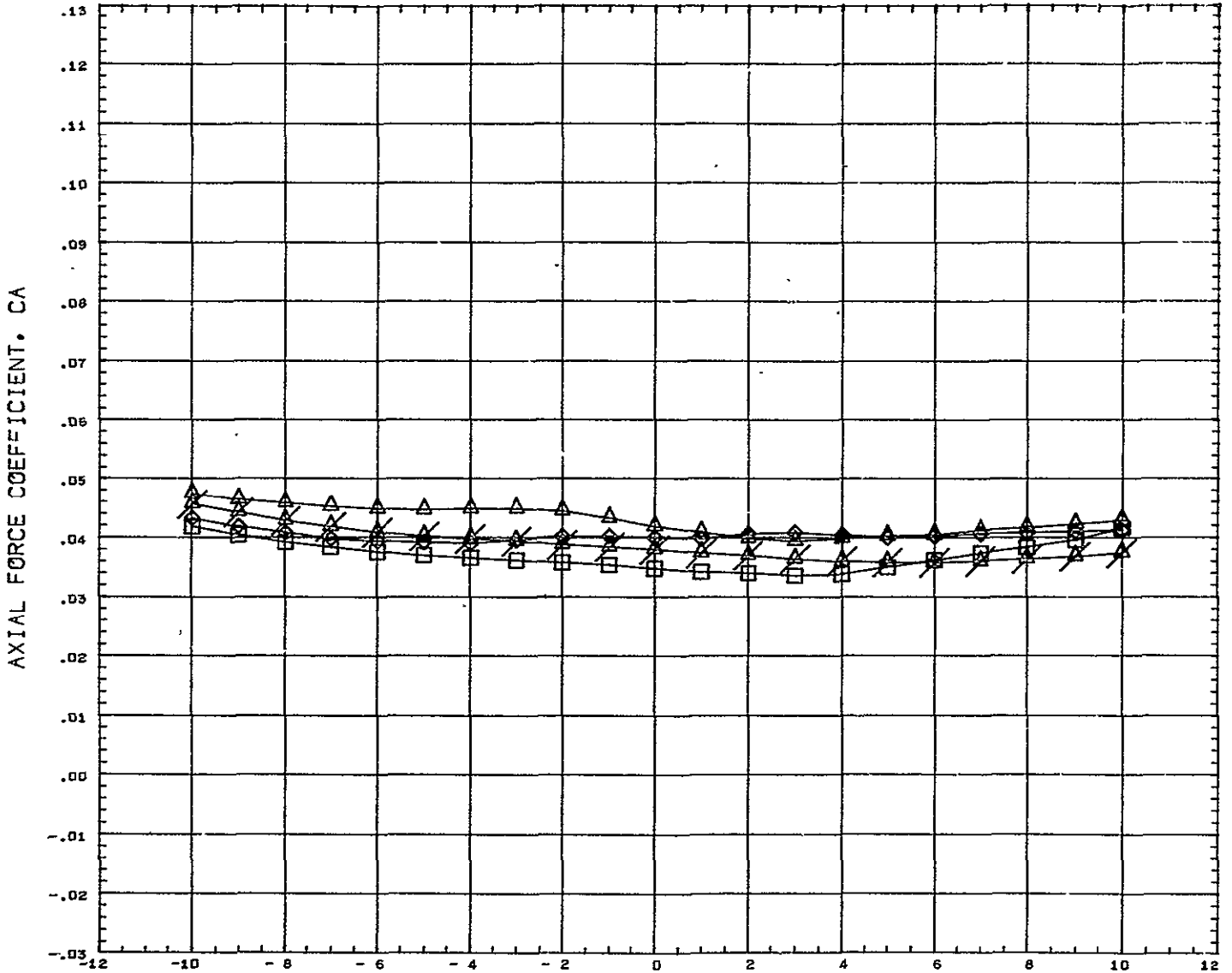

SYMBOL △ ◇ □ ×	DELTAZ 0.151 0.182 0.228 10.000	<table border="0" style="width: 100%;"> <tr> <th colspan="4" style="text-align: left; padding-left: 20px;">PARAMETRIC VALUES</th> </tr> <tr> <td style="padding-left: 20px;">BSTPOW</td> <td>50.000</td> <td style="padding-left: 20px;">ORBPOW</td> <td>50.000</td> </tr> <tr> <td style="padding-left: 20px;">DELTA X</td> <td>0.166</td> <td style="padding-left: 20px;">ALPHA I</td> <td>5.000</td> </tr> <tr> <td style="padding-left: 20px;">MACH</td> <td>5.010</td> <td style="padding-left: 20px;">ELVBST</td> <td>0.000</td> </tr> <tr> <td style="padding-left: 20px;">ELVORB</td> <td>0.000</td> <td style="padding-left: 20px;">BETA</td> <td>0.000</td> </tr> </table>	PARAMETRIC VALUES				BSTPOW	50.000	ORBPOW	50.000	DELTA X	0.166	ALPHA I	5.000	MACH	5.010	ELVBST	0.000	ELVORB	0.000	BETA	0.000	<table border="0" style="width: 100%;"> <tr> <th colspan="3" style="text-align: left; padding-left: 20px;">REFERENCE INFORMATION</th> </tr> <tr> <td style="padding-left: 20px;">REFS</td> <td>23.6890</td> <td style="padding-left: 20px;">SQ IN</td> </tr> <tr> <td style="padding-left: 20px;">REFL</td> <td>4.1930</td> <td style="padding-left: 20px;">IN</td> </tr> <tr> <td style="padding-left: 20px;">REFS</td> <td>6.5900</td> <td style="padding-left: 20px;">IN</td> </tr> <tr> <td style="padding-left: 20px;">XMRP</td> <td>4.9170</td> <td style="padding-left: 20px;">IN</td> </tr> <tr> <td style="padding-left: 20px;">YMRP</td> <td>0.0000</td> <td style="padding-left: 20px;">IN</td> </tr> <tr> <td style="padding-left: 20px;">ZMRP</td> <td>1.3900</td> <td style="padding-left: 20px;">IN</td> </tr> <tr> <td style="padding-left: 20px;">SCALE</td> <td>0.0055</td> <td></td> </tr> </table>	REFERENCE INFORMATION			REFS	23.6890	SQ IN	REFL	4.1930	IN	REFS	6.5900	IN	XMRP	4.9170	IN	YMRP	0.0000	IN	ZMRP	1.3900	IN	SCALE	0.0055	
PARAMETRIC VALUES																																															
BSTPOW	50.000	ORBPOW	50.000																																												
DELTA X	0.166	ALPHA I	5.000																																												
MACH	5.010	ELVBST	0.000																																												
ELVORB	0.000	BETA	0.000																																												
REFERENCE INFORMATION																																															
REFS	23.6890	SQ IN																																													
REFL	4.1930	IN																																													
REFS	6.5900	IN																																													
XMRP	4.9170	IN																																													
YMRP	0.0000	IN																																													
ZMRP	1.3900	IN																																													
SCALE	0.0055																																														

REFERENCE FILE



# AEDC VA 1163 MDAC BOOSTER AND ORBITER TEST DATA AT MACH NUMBER 5

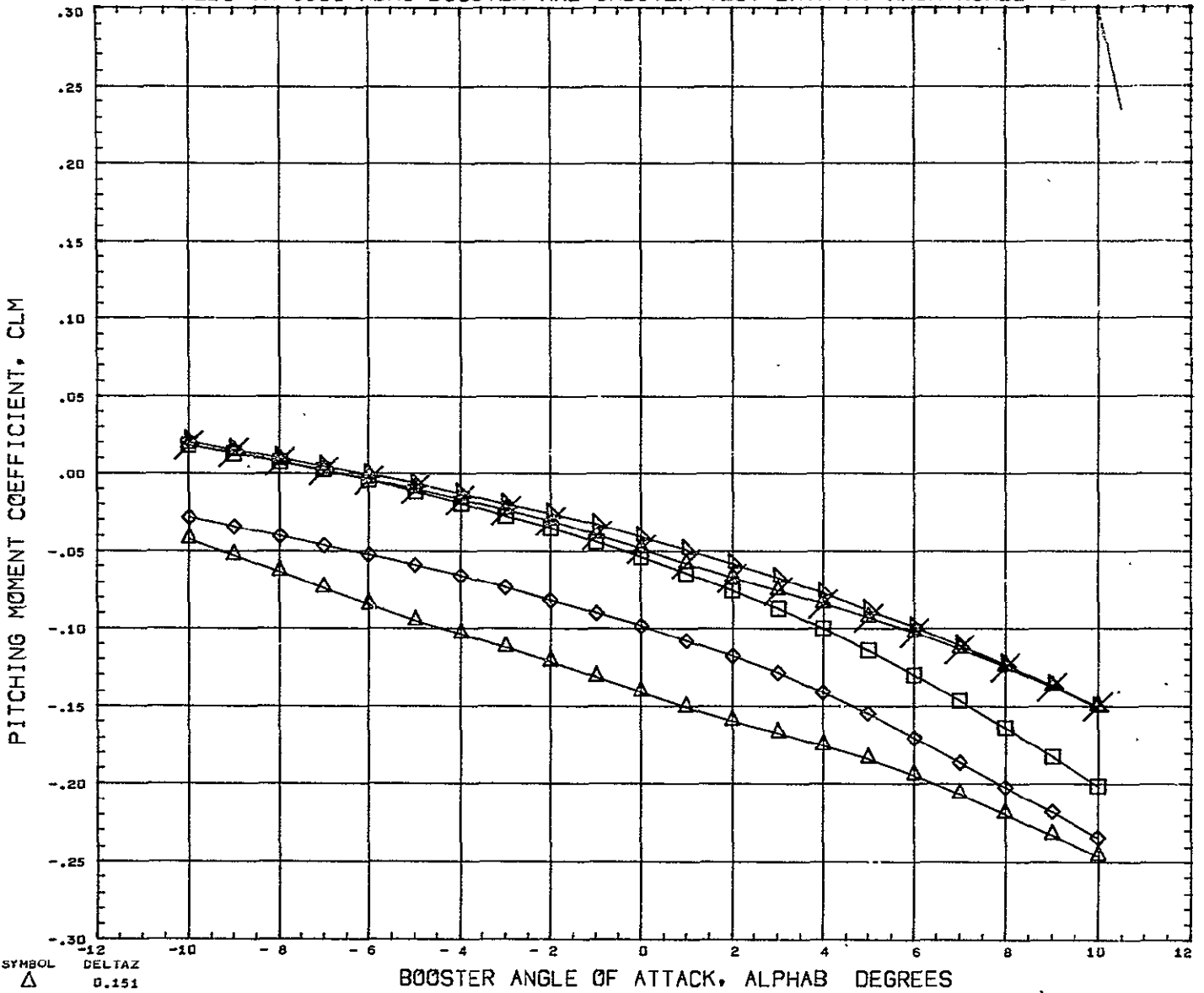

SYMBOL △ ◇ □ ×	DELTAZ 0.151 0.182 0.228 0.352 10.000	<table border="0" style="width: 100%;"> <tr> <th colspan="4" style="text-align: left;">PARAMETRIC VALUES</th> </tr> <tr> <td>BSTFOW</td><td>50.000</td><td>ORBFOW</td><td>50.000</td></tr> <tr> <td>DELTAZ</td><td>0.351</td><td>ALPHA1</td><td>5.000</td></tr> <tr> <td>MACH</td><td>5.010</td><td>ELVBST</td><td>0.000</td></tr> <tr> <td>ELVORB</td><td>0.000</td><td>BETA</td><td>0.000</td></tr> </table>	PARAMETRIC VALUES				BSTFOW	50.000	ORBFOW	50.000	DELTAZ	0.351	ALPHA1	5.000	MACH	5.010	ELVBST	0.000	ELVORB	0.000	BETA	0.000	<table border="0" style="width: 100%;"> <tr> <th colspan="3" style="text-align: left;">REFERENCE INFORMATION</th> </tr> <tr> <td>REFS</td><td>23.6890</td><td>SQ IN</td></tr> <tr> <td>REPL</td><td>4.1930</td><td>IN</td></tr> <tr> <td>REFB</td><td>6.5000</td><td>IN</td></tr> <tr> <td>XMRP</td><td>4.9170</td><td>IN</td></tr> <tr> <td>YMRP</td><td>0.0000</td><td>IN</td></tr> <tr> <td>ZMRP</td><td>1.3900</td><td>IN</td></tr> <tr> <td>SCALE</td><td>0.0055</td><td></td></tr> </table>	REFERENCE INFORMATION			REFS	23.6890	SQ IN	REPL	4.1930	IN	REFB	6.5000	IN	XMRP	4.9170	IN	YMRP	0.0000	IN	ZMRP	1.3900	IN	SCALE	0.0055	
PARAMETRIC VALUES																																															
BSTFOW	50.000	ORBFOW	50.000																																												
DELTAZ	0.351	ALPHA1	5.000																																												
MACH	5.010	ELVBST	0.000																																												
ELVORB	0.000	BETA	0.000																																												
REFERENCE INFORMATION																																															
REFS	23.6890	SQ IN																																													
REPL	4.1930	IN																																													
REFB	6.5000	IN																																													
XMRP	4.9170	IN																																													
YMRP	0.0000	IN																																													
ZMRP	1.3900	IN																																													
SCALE	0.0055																																														
REFERENCE FILE																																															

# AEDC VA 1163 MDAC BOOSTER AND ORBITER TEST DATA AT MACH NUMBER 5

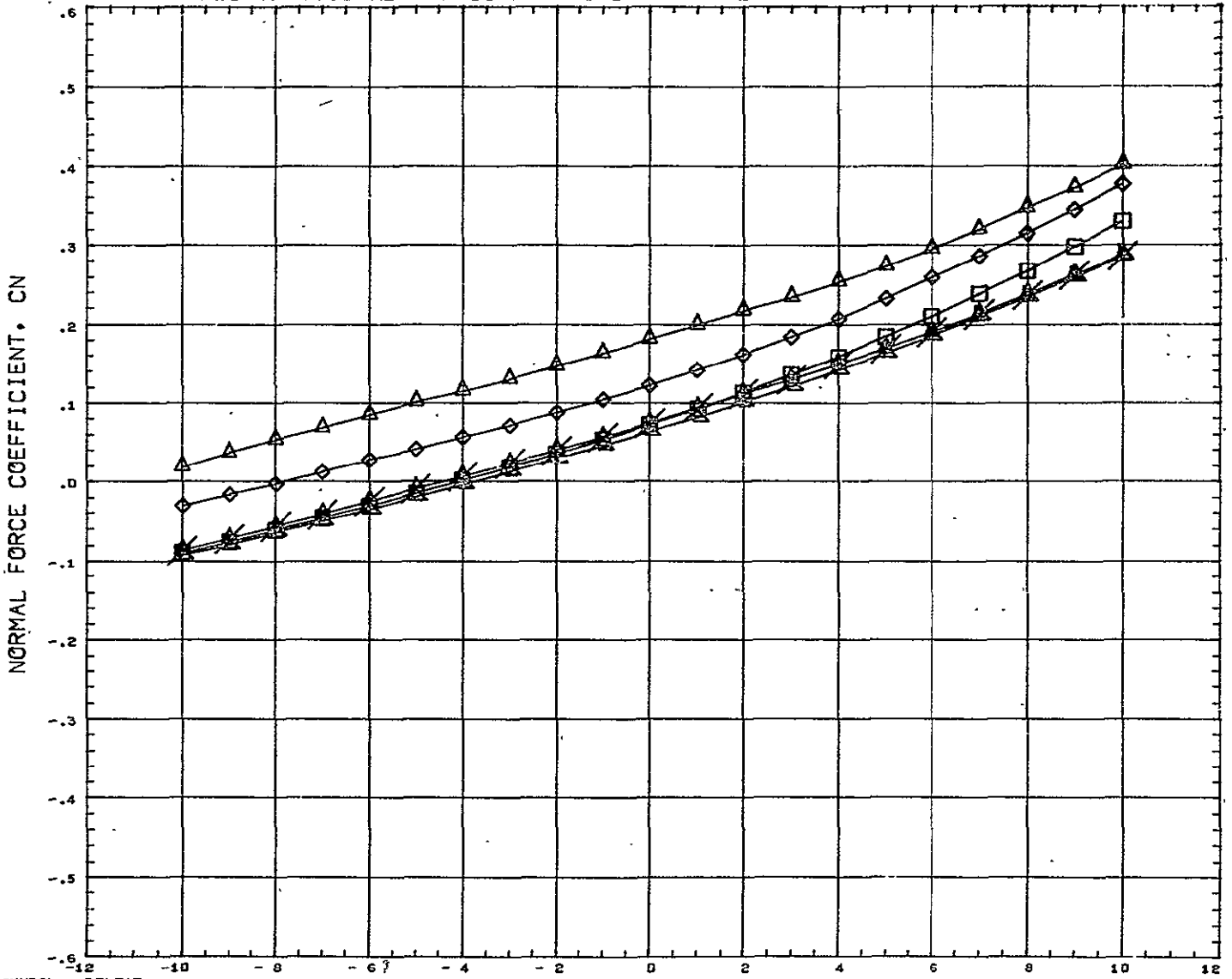

SYMBOL △ ◇ □ × *	DELTAZ 0.151 0.182 0.228 0.352 10.000	<b>PARAMETRIC VALUES</b> BSTFOW 50.000 ORBPOW 50.000 DELTAX 0.351 ALPHAI 5.000 MACH 5.010 ELVBST 0.000 ELVORB 0.000 BETA 0.000	<b>REFERENCE INFORMATION</b> REFS 23.6890 SQ IN REFL 4.1930 IN REFD 6.5000 IN XMRP 4.9170 IN YMRP 0.0000 IN ZMRP 1.3900 IN SCALE 0.0055
---------------------------------	--	--	--

REFERENCE FILE

# AEDC VA 1163 MDAC BOOSTER AND ORBITER TEST DATA AT MACH NUMBER 5

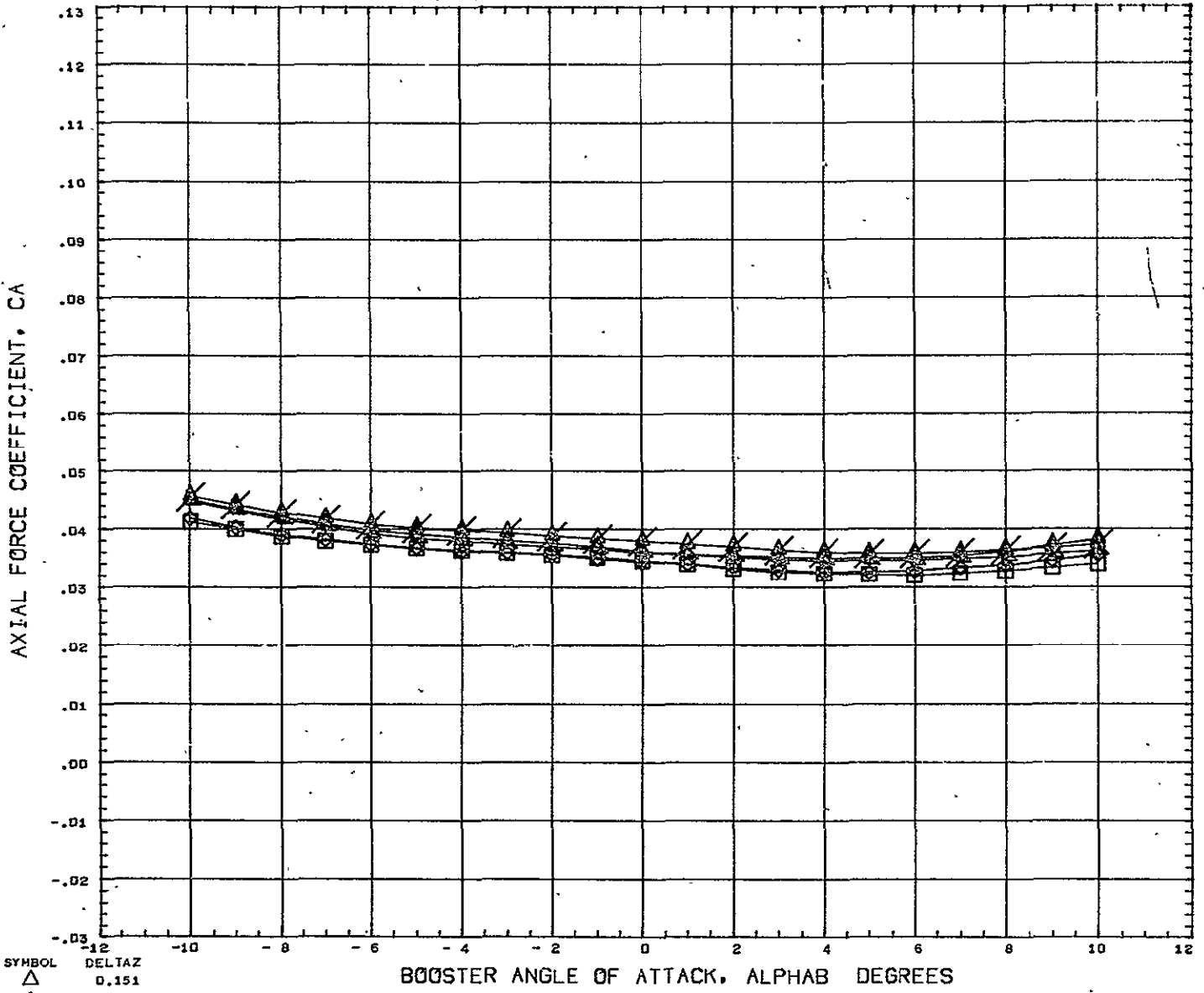

SYMBOL △ ◇ ◻ ◻ △	DELTAZ 0.151 0.182 0.228 0.352 10.000	<table border="0" style="width: 100%;"> <tr> <th colspan="4" style="text-align: left; padding-left: 20px;">PARAMETRIC VALUES</th> </tr> <tr> <td style="padding-right: 10px;">BSTPOW</td> <td style="padding-right: 10px;">50.000</td> <td style="padding-right: 10px;">ORBPOW</td> <td>50.000</td> </tr> <tr> <td>DELTA X</td> <td>0.351</td> <td>ALPHA I</td> <td>5.000</td> </tr> <tr> <td>MACH</td> <td>5.010</td> <td>ELVBST</td> <td>0.000</td> </tr> <tr> <td>ELVORB</td> <td>0.000</td> <td>BETA</td> <td>0.000</td> </tr> </table>	PARAMETRIC VALUES				BSTPOW	50.000	ORBPOW	50.000	DELTA X	0.351	ALPHA I	5.000	MACH	5.010	ELVBST	0.000	ELVORB	0.000	BETA	0.000	<table border="0" style="width: 100%;"> <tr> <th colspan="3" style="text-align: left;">REFERENCE INFORMATION</th> </tr> <tr> <td>REFS</td> <td>23.6890</td> <td>SQ IN</td> </tr> <tr> <td>REFL</td> <td>4.1930</td> <td>IN</td> </tr> <tr> <td>REFB</td> <td>6.5000</td> <td>IN</td> </tr> <tr> <td>XMRP</td> <td>4.9170</td> <td>IN</td> </tr> <tr> <td>YMRP</td> <td>0.0005</td> <td>IN</td> </tr> <tr> <td>ZMRP</td> <td>1.3900</td> <td>IN</td> </tr> <tr> <td>SCALE</td> <td>0.0055</td> <td></td> </tr> </table>	REFERENCE INFORMATION			REFS	23.6890	SQ IN	REFL	4.1930	IN	REFB	6.5000	IN	XMRP	4.9170	IN	YMRP	0.0005	IN	ZMRP	1.3900	IN	SCALE	0.0055	
PARAMETRIC VALUES																																															
BSTPOW	50.000	ORBPOW	50.000																																												
DELTA X	0.351	ALPHA I	5.000																																												
MACH	5.010	ELVBST	0.000																																												
ELVORB	0.000	BETA	0.000																																												
REFERENCE INFORMATION																																															
REFS	23.6890	SQ IN																																													
REFL	4.1930	IN																																													
REFB	6.5000	IN																																													
XMRP	4.9170	IN																																													
YMRP	0.0005	IN																																													
ZMRP	1.3900	IN																																													
SCALE	0.0055																																														

REFERENCE FILE

# AEDC VA 1163 MDAC BOOSTER AND ORBITER TEST DATA AT MACH NUMBER 5

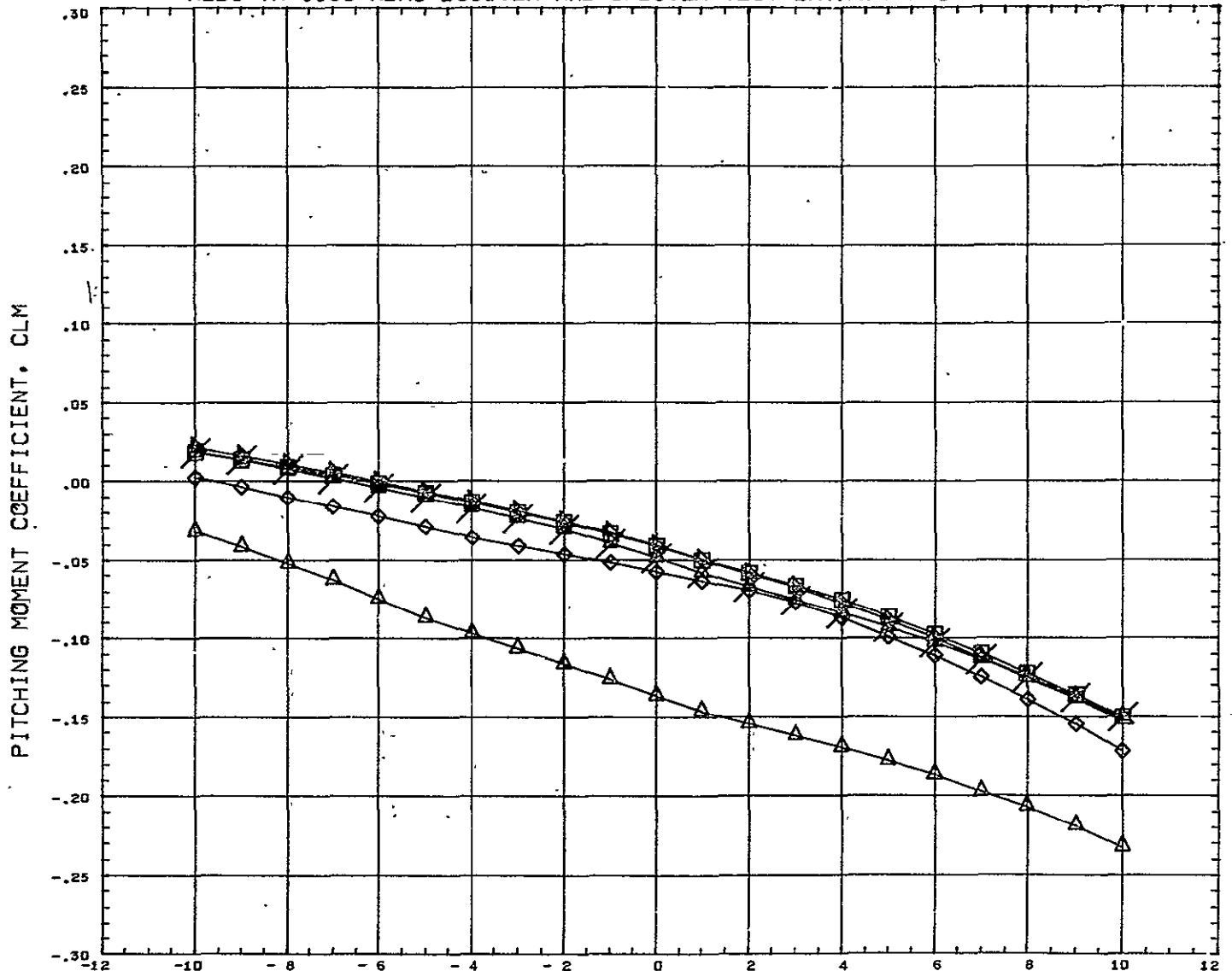

SYMBOL △ ◇ □ × ☆	DELTA Z 0.151 0.182 0.228 0.352 10.000	PARAMETRIC VALUES BSTPOW 50.000 ORBPOW 50.000 DELTAX 0.521 ALPHAI 5.000 MACH 5.010 ELVBST 0.000 ELVORB 0.000 BETA 0.000	REFERENCE INFORMATION REFS 23.6890 SQ IN REFL 4.1930 IN REFB 6.5000 IN XMRP 4.9170 IN YMRP 0.0000 IN ZMRP 1.3900 IN SCALE 0.0055
REFERENCE FILE			

# AEDC VA 1163 MDAC BOOSTER AND ORBITER TEST DATA AT MACH NUMBER 5

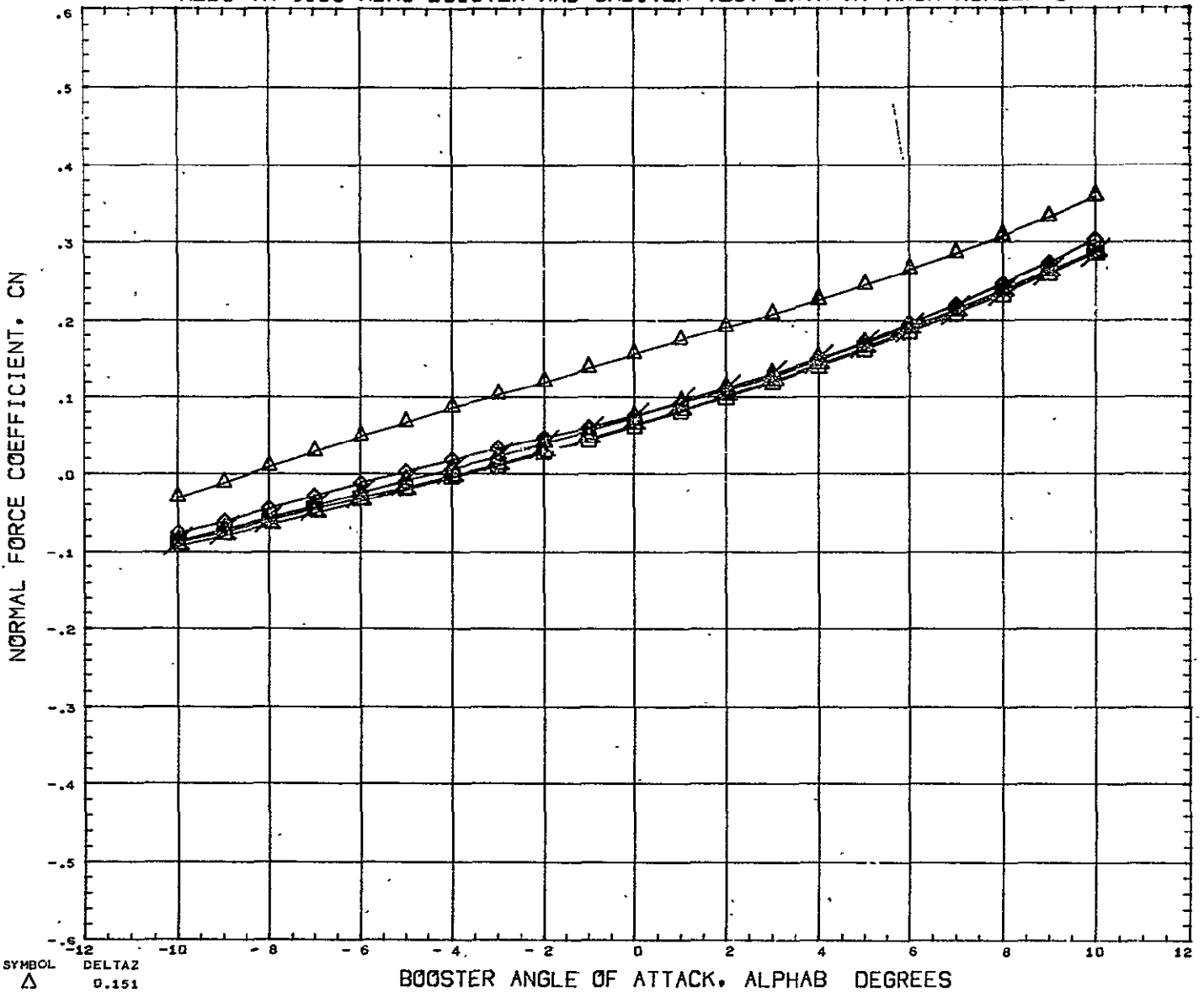

SYMBOL △ ◊ ◻ ○	DELTAZ 0.151 0.182 0.228 0.352 10.000	PARAMETRIC VALUES BSTPOW 50.000 ORBPOW 50.000 DELTAX 0.521 ALPHAI 5.000 MACH 5.010 ELVBST 0.000 ELVORB 0.000 BETA 0.000	REFERENCE INFORMATION REFS 23.6890 SQ IN REFL 4.1930 IN REFB 6.5900 IN XMRF 4.9170 IN YMRP 0.0000 IN ZMRP 1.3900 IN SCALE 0.0055
REFERENCE FILE			

# AEDC VA 1163 MDAC BOOSTER AND ORBITER TEST DATA AT MACH NUMBER 5

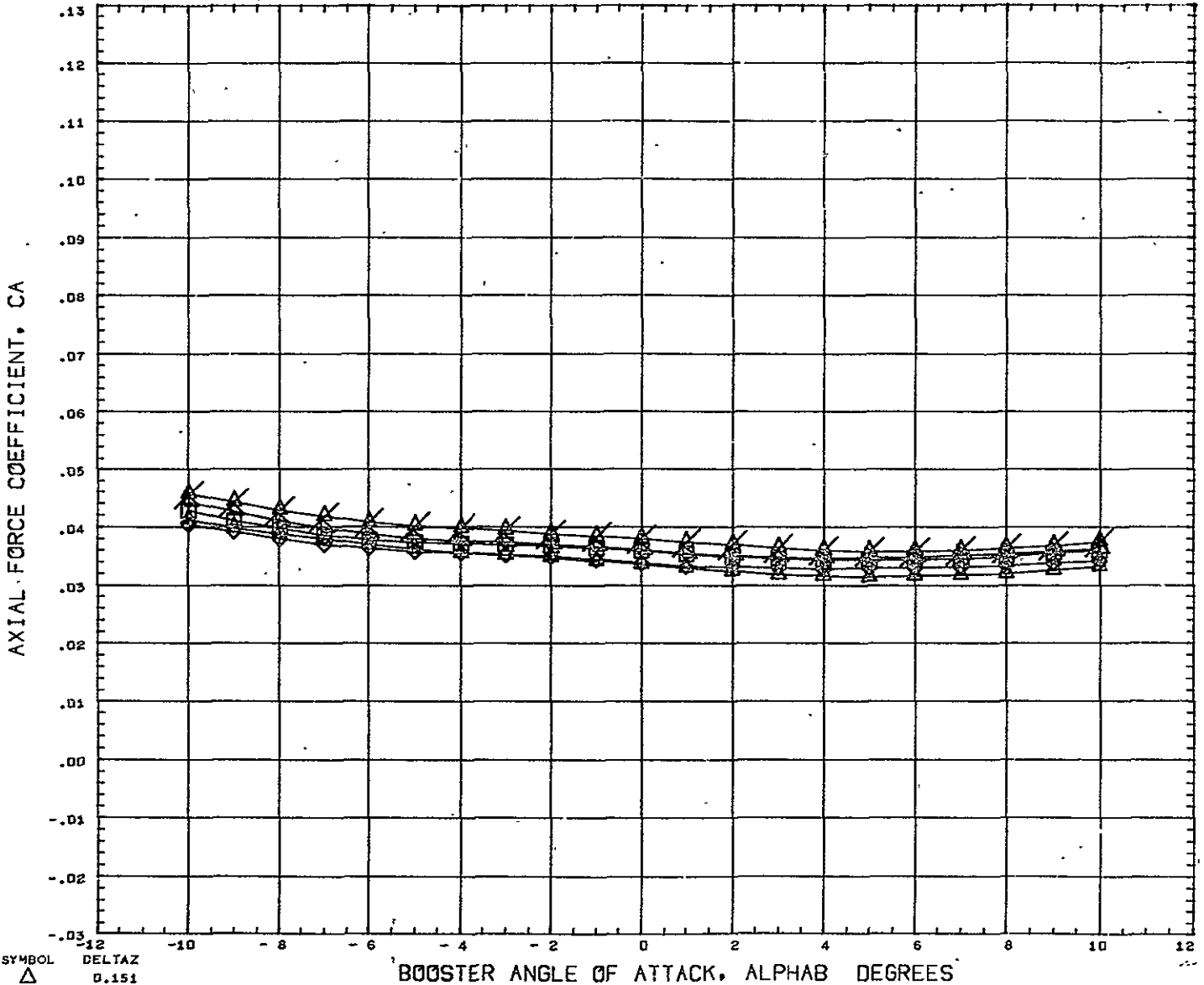

SYMBOL 	DELTAX 0.151 0.182 0.228 0.352 10.000	PARAMETRIC VALUES BSTPOW 50.000 ORBPOW 50.000 DELTAX 0.521 ALPHAI 5.000 MACH 5.010 ELVBST 0.000 ELVORB 0.000 BETA 0.000	REFERENCE INFORMATION REFS 23.6890 SQ IN REFL 4.1930 IN REFB 6.5000 IN XMRP 4.9170 IN YMRP 0.0000 IN ZMRP 1.3900 IN SCALE 0.0055
------------	--	---	---

REFERENCE FILE

AEDC VA 1163 MDAC BOOSTER AND ORBITER TEST DATA AT MACH NUMBER 5

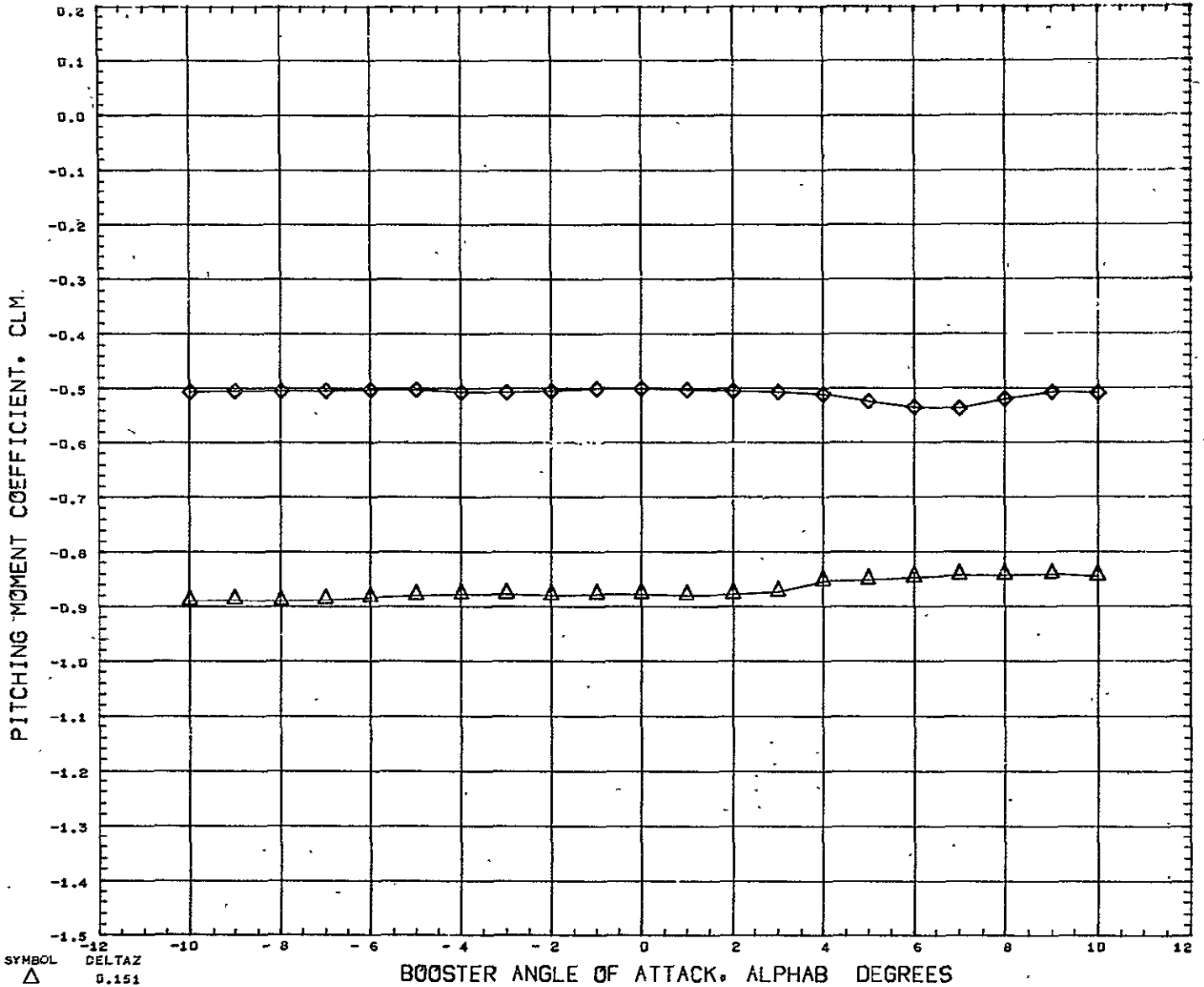

SYMBOL  
 △ DELTAX 0.151  
 ◇ DELTAY 0.182

PARAMETRIC VALUES  
 BSTPOW 50.000 ORBPOW 25.000  
 DELTAX - 0.391 ALPHA1 5.000  
 MACH 5.010 ELVBST 0.000  
 ELVORB 0.000 BETA 0.000

REFERENCE INFORMATION  
 REFS 23.6890 SQ IN  
 REFL 4.1930 IN  
 REFS 6.5000 IN  
 XMRP 4.9177 IN  
 YMRP 0.0000 IN  
 ZMRP 1.3900 IN  
 SCALE 0.0055

REFERENCE FILE

# AEDC VA 1163 MDAC BOOSTER AND ORBITER TEST DATA AT MACH NUMBER 5

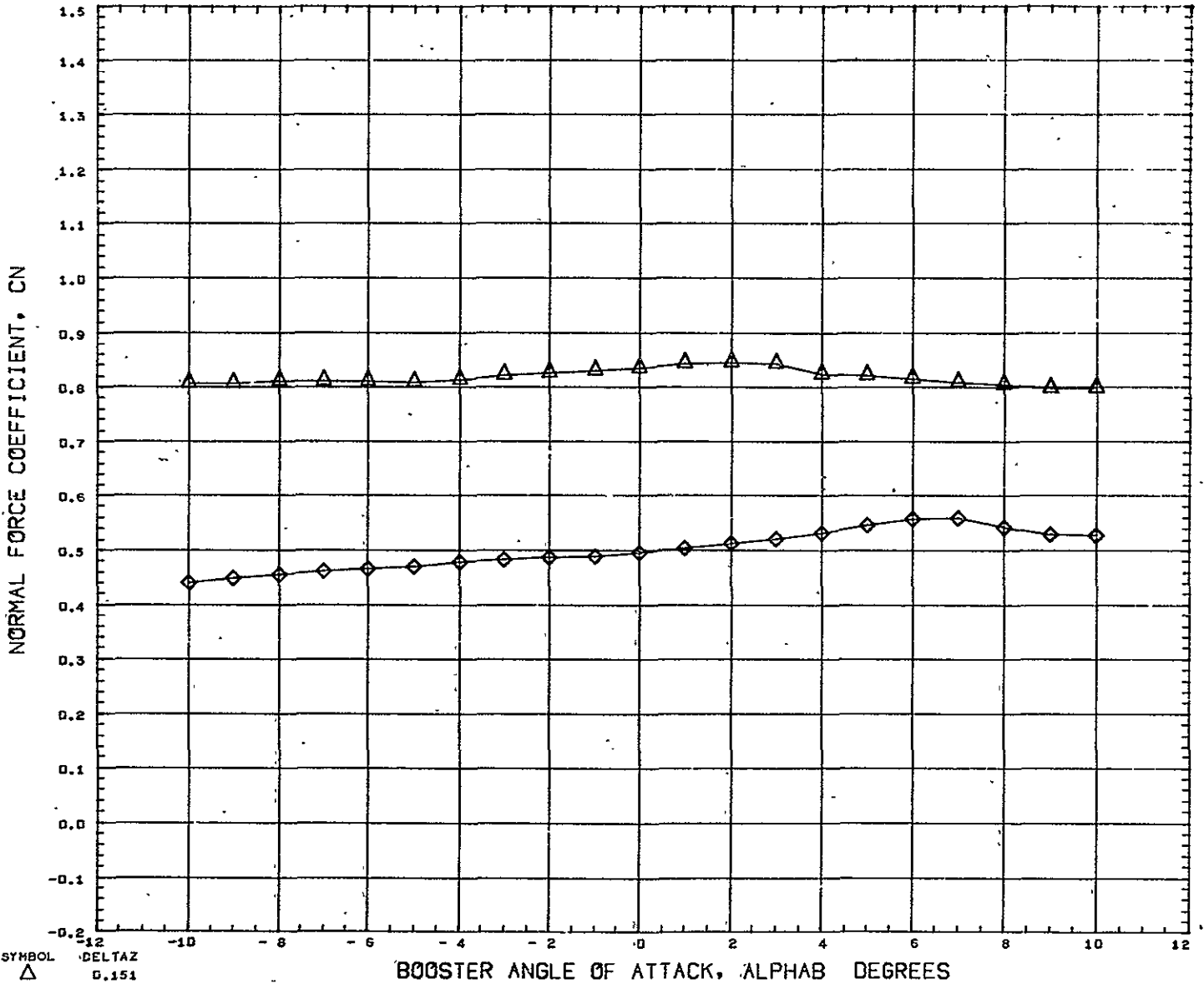

SYMBOL	DELTAZ	PARAMETRIC VALUES		REFERENCE INFORMATION					
△	0.151	BSTPOW	50.000	ORBPOW	25.000	REFS	23.6890	SQ	IN
◇	0.182	DELTAZ	-0.391	ALPHA1	5.000	REFL	4.1930	IN	
		MACH	5.010	ELVBST	0.000	REFB	6.5000	IN	
		ELVORB	0.000	BETA	0.000	XHRF	4.9170	IN	
						YHRF	0.0000	IN	
						ZHRF	1.3900	IN	
						SCALE	0.0055		

REFERENCE FILE



# AEDC VA 1163 MDAC BOOSTER AND ORBITER TEST DATA AT MACH NUMBER 5

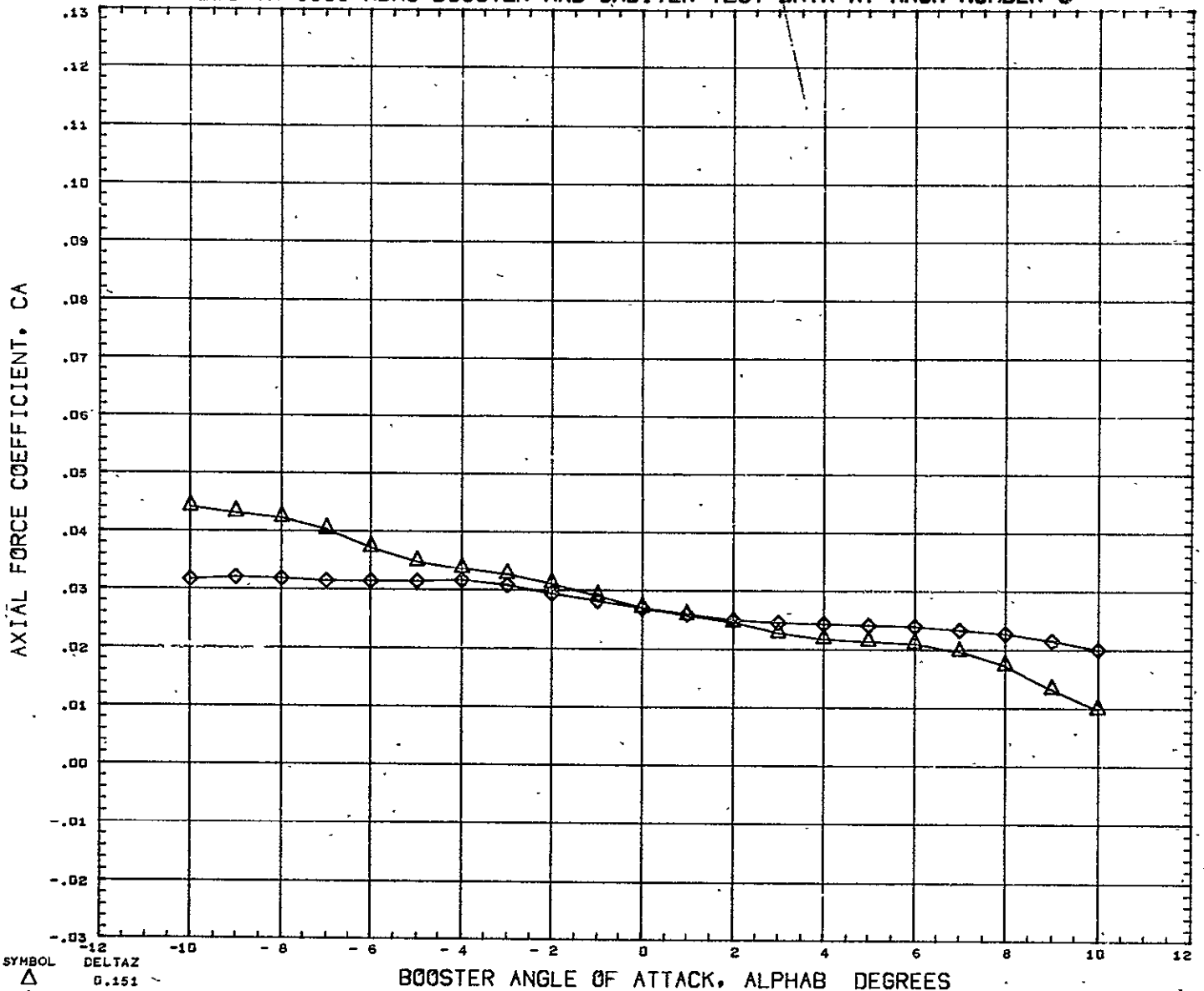

SYMBOL  $\triangle$  DELTA Z 0.151  
 $\diamond$  0.182

PARAMETRIC VALUES

BSTPOW	50.000	ORBPOW	25.000
DELTA X	-0.391	ALPHA I	5.000
MACH	5.010	ELVBST	0.000
ELVORB	0.000	BETA	0.000

REFERENCE INFORMATION

REFS	23.6890	SQ IN
REFL	4.1930	IN
REFB	6.5000	IN
XMRP	4.9170	IN
YMRP	0.0000	IN
ZMRP	1.3900	IN
SCALE	0.0055	

REFERENCE FILE

# AEDC VA 1163 MDAC BOOSTER AND ORBITER TEST DATA AT MACH NUMBER 5

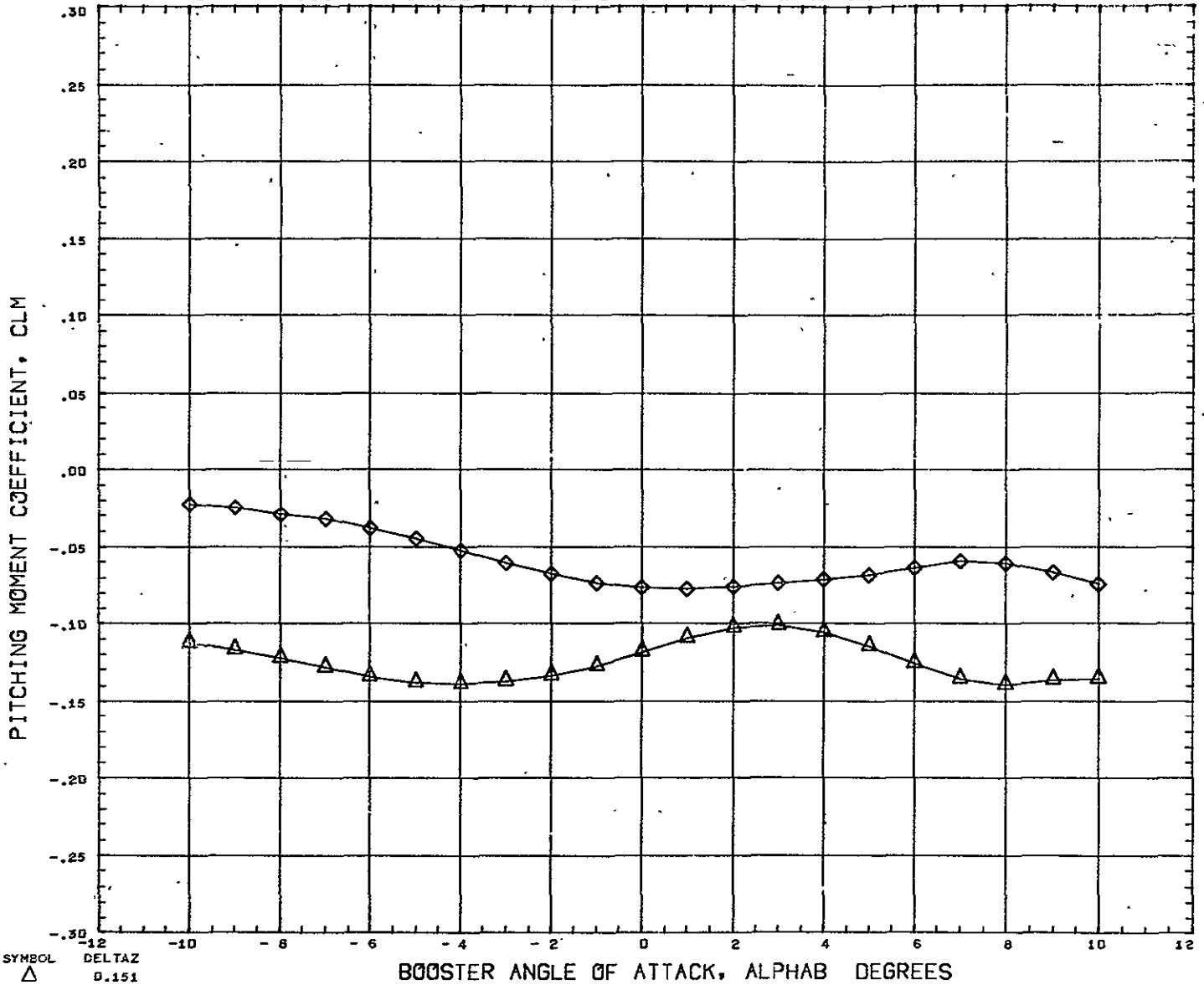

SYMBOL	DELTAZ			
△	0.151			
◇	0.182			
	PARAMETRIC VALUES			REFERENCE INFORMATION
	BSTPOW	50.000	ORBPOW	25.000
	DELTAZ	0.143	ALPHA1	5.000
	MACH	5.010	ELVBST	0.000
	ELVORB	0.000	BETA	0.000
	REFERENCE FILE			
			REFS	23.6890 SQ IN
			REFL	4.1930 IN
			REFB	6.5000 IN
			XMRP	4.9170 IN
			YMRP	0.0000 IN
			ZMRP	1.3900 IN
			SCALE	0.0055

# AEDC VA 1163 MDAC BOOSTER AND ORBITER TEST DATA AT MACH NUMBER 5

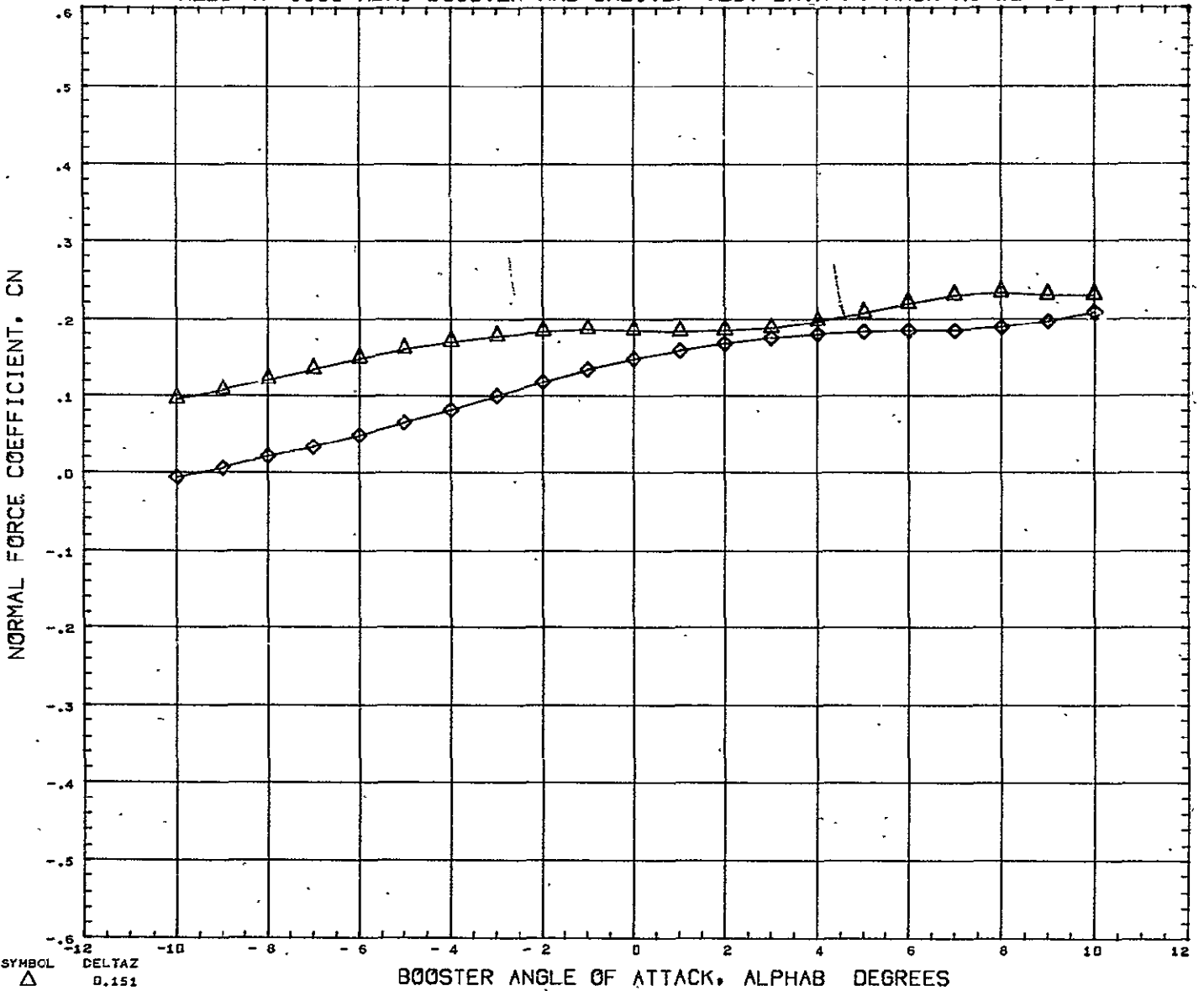

SYMBOL    DELTA Z  
 △        0.151  
 ◇        0.182

PARAMETRIC VALUES  
 BSTPOW    50.000    ORBPOW    25.000  
 DELTAX    - 0.143    ALPHAI    5.000  
 MACH       5.010    ELVBST    0.000  
 ELVORB    0.000    BETA       0.000

REFERENCE INFORMATION  
 REFS       23.6890    SQ IN  
 REFL       4.1930    IN  
 REFB       6.5000    IN  
 XHRP       4.9170    IN  
 YHRP       0.0000    IN  
 ZHRP       1.3900    IN  
 SCALE      0.0055

REFERENCE FILE

# AEDC VA 1163 MDAC BOOSTER AND ORBITER TEST DATA AT MACH NUMBER 5

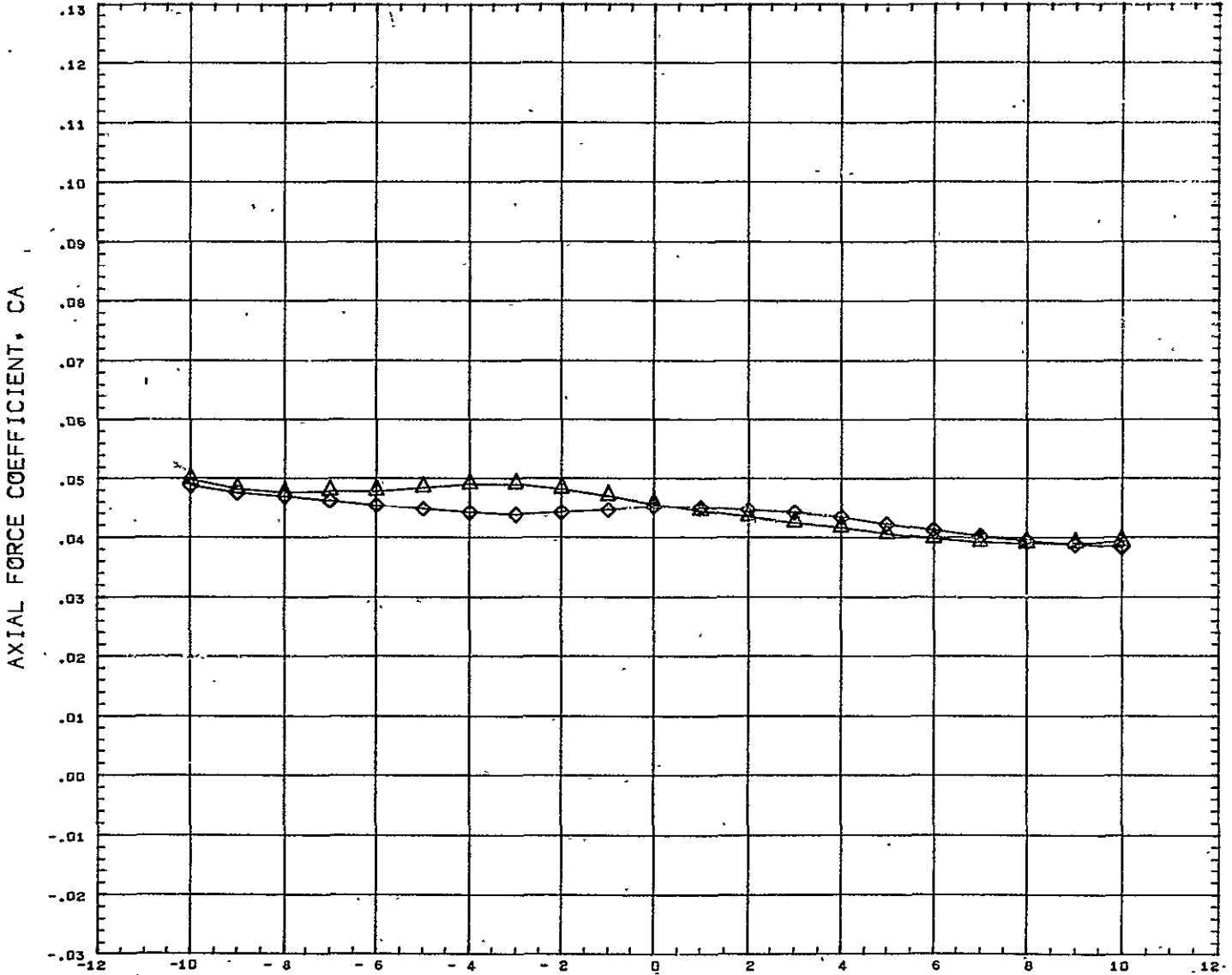

SYMBOL    DELTA Z  
 △        0.151  
 ◇        0.182

BOOSTER ANGLE OF ATTACK, ALPHAB DEGREES

PARAMETRIC VALUES

BSTPOW	50.000	ORBPOW	25.000
DELTA X	0.143	ALPHA I	5.000
MACH.	5.010	ELVBST	0.000
ELVORB	0.000	BETA	0.000

REFERENCE INFORMATION

REFS	23.6890	SQ IN
REFL	4.1930	IN
REFB	6.5000	IN
XMRP	4.9170	IN
YMRP	0.0000	IN
ZMRP	1.3900	IN
SCALE	0.0055	

REFERENCE FILE

# AEDC VA 1163 MDAC BOOSTER AND ORBITER TEST DATA AT MACH NUMBER 5

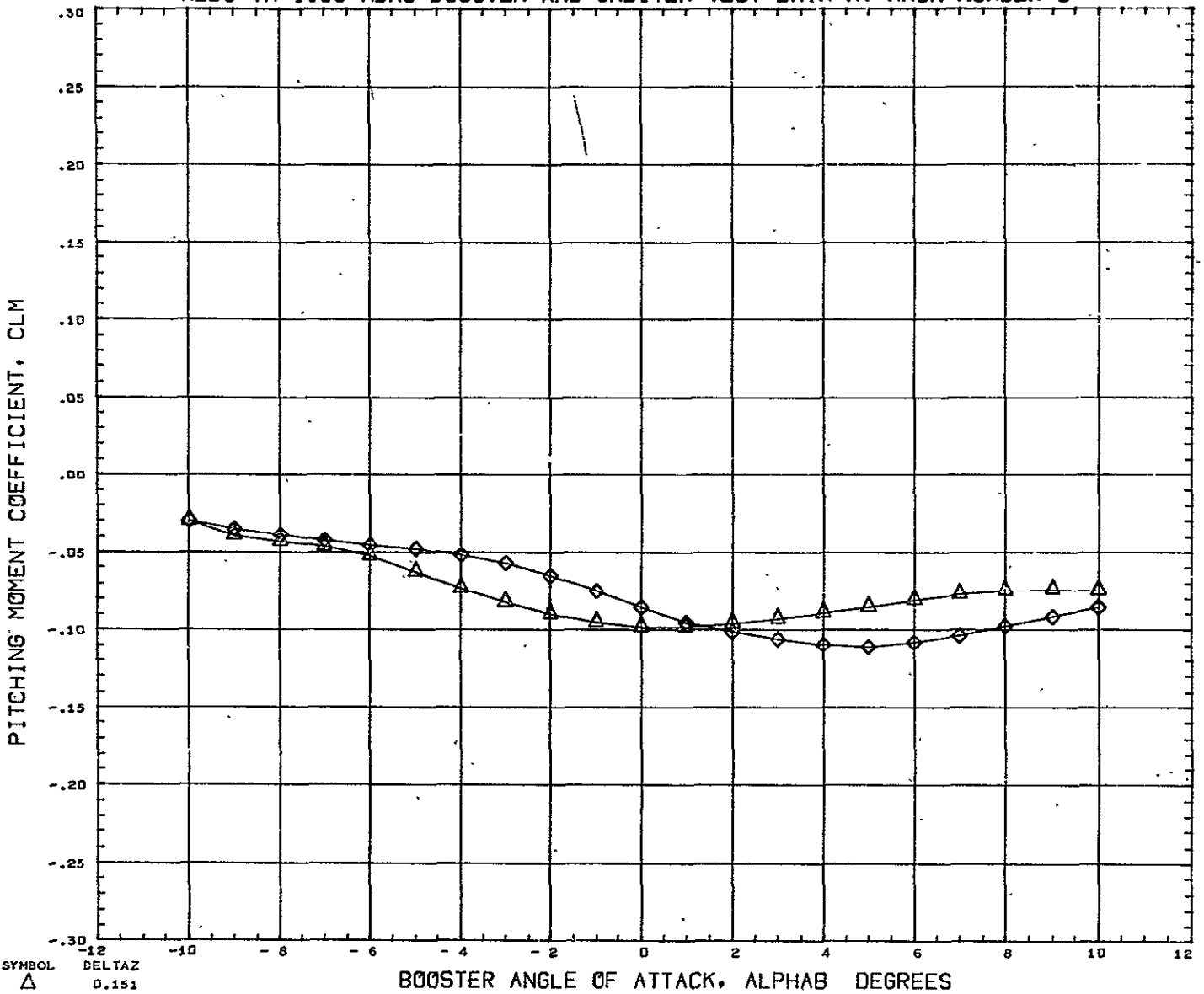

SYMBOL    DELTA Z  
 △        0.151  
 ◇        0.182

PARAMETRIC VALUES

BSTPOW	50.000	ORBPOW	25.000
DELTA X	0.019	ALPHA I	5.000
MACH	5.010	ELVBST	0.000
ELVORB	0.000	BETA	0.000

REFERENCE INFORMATION

REFS	23.6890	SQ IN
REFL	4.1930	IN
REFB	6.5000	IN
XMRP	4.9170	IN
YMRP	0.0000	IN
ZMRP	1.3900	IN
SCALE	0.0055	

REFERENCE FILE

# AEDC VA 1163 MDAC BOOSTER AND ORBITER TEST DATA AT MACH NUMBER 5

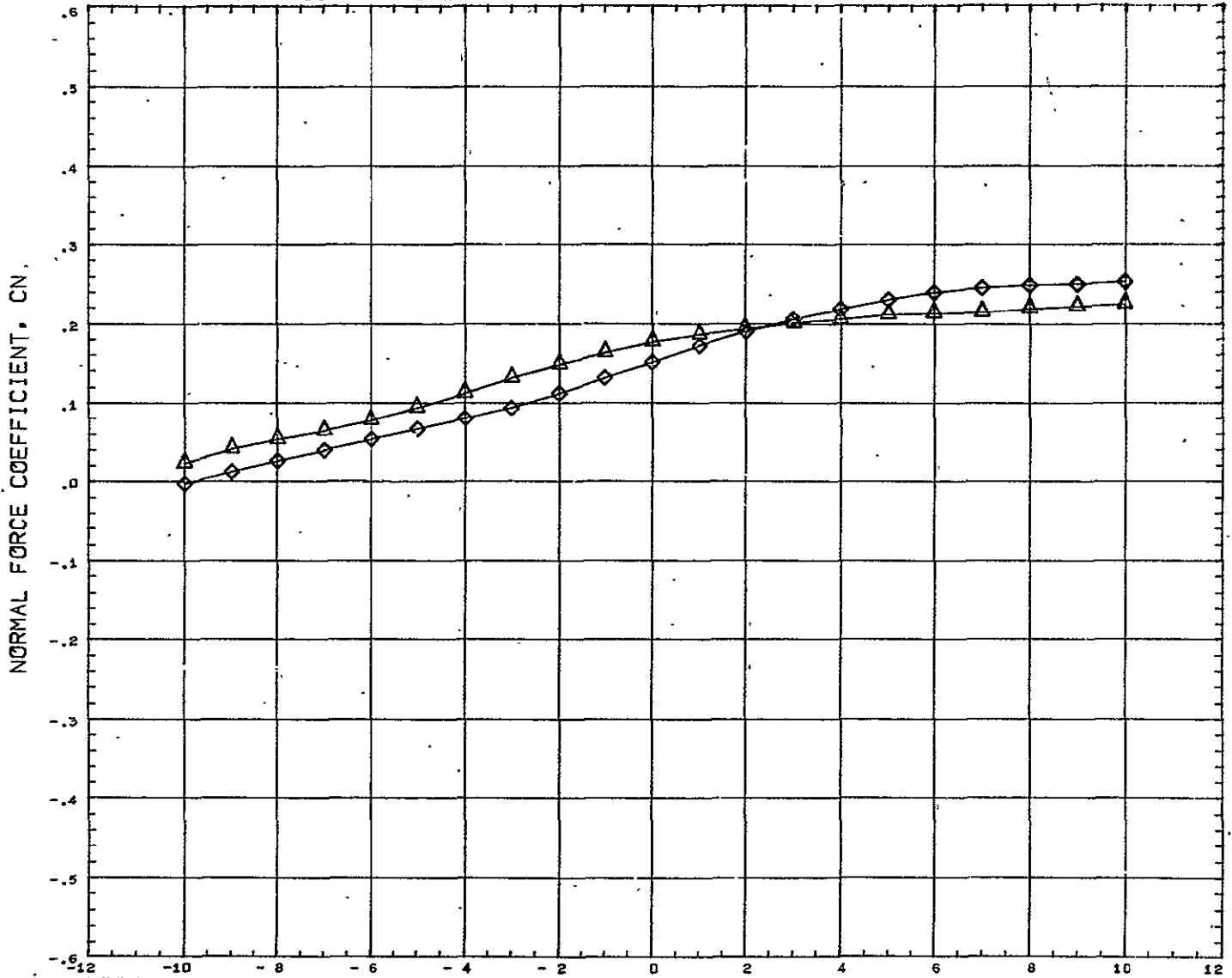

SYMBOL  
 △  
 ◇

DELTA Z  
 0.151  
 0.182

BOOSTER ANGLE OF ATTACK, ALPHA DEGREES

PARAMETRIC VALUES

BSTPOW	50.000	ORBPOW	25.000
DELTA Z	0.019	ALPHA I	5.000
MACH	5.010	ELVBSI	0.000
ELVORB	0.000	BETA	0.000

REFERENCE INFORMATION

REFS	23.6890	SQ IN
REFL	4.1930	IN
REFB	6.5000	IN
XMRP	4.9170	IN
YMRP	0.0000	IN
ZMRP	1.3900	IN
SCALE	0.0055	

REFERENCE FILE

# AEDC VA 1163 MDAC BOOSTER AND ORBITER TEST DATA AT MACH NUMBER 5

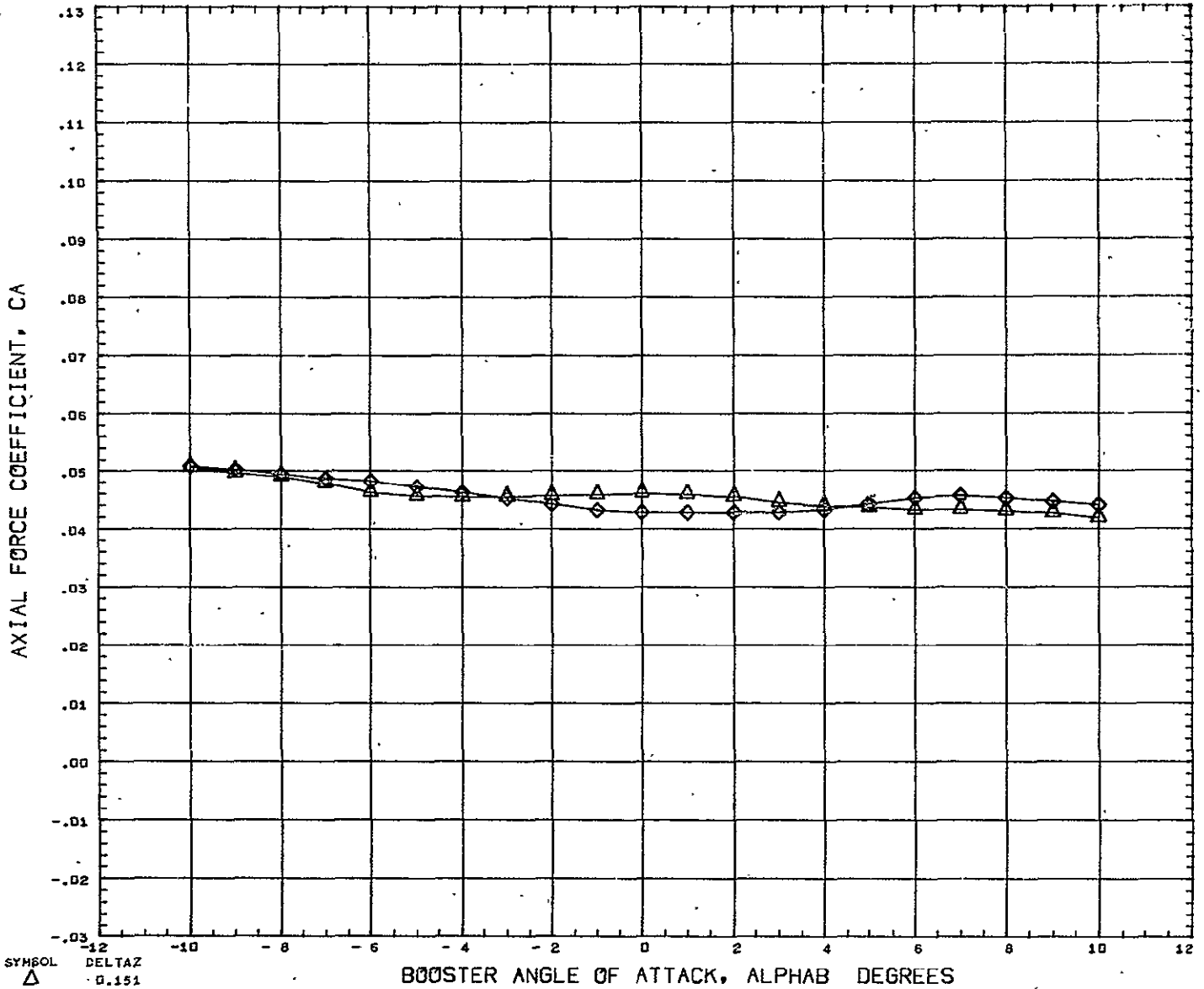

SYMBOL    DELTA Z  
 △        0.151  
 ◇        0.182

BOOSTER ANGLE OF ATTACK, ALPHAB DEGREES

PARAMETRIC VALUES

BSTPOW	50.000	ORBPOW	25.000
DELTAZ	- 0.019	ALPHA1	5.000
MACH	5.010	ELVBST	0.000
ELVORB	0.000	BETA	0.100

REFERENCE INFORMATION

REFS	23.6890	SQ IN
REFL	4.1930	IN
REFB	6.5000	IN
XMRP	4.9170	IN
YMRP	0.0000	IN
ZMRP	1.3900	IN
SCALE	0.0055	

REFERENCE FILE

# AEDC VA 1163 MDAC BOOSTER AND ORBITER TEST DATA AT MACH NUMBER 5

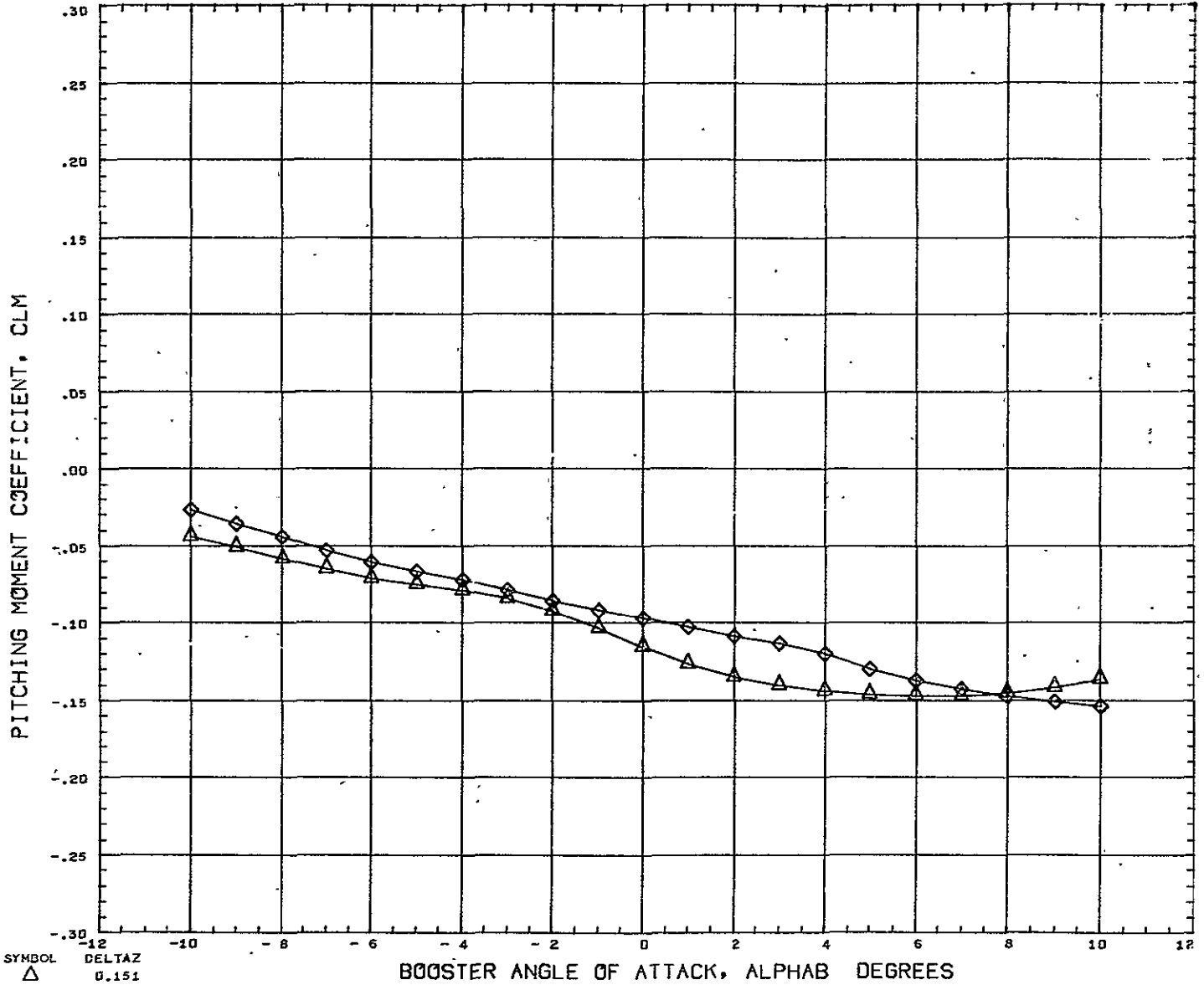

SYMBOL    DELTA Z  
 △        0.151  
 ◇        0.182

PARAMETRIC VALUES  
 BSTPOW    50.000    ORBPOW    25.000  
 DELTAX    0.104    ALPHAI    5.000  
 MACH       5.010    ELVBST    0.000  
 ELVORB    0.000    BETA      0.000

REFERENCE INFORMATION  
 REFS       23.6890    SQ IN  
 REFL       4.1930    IN  
 REFB       6.5000    IN  
 XMRP       4.9170    IN  
 YMRP       0.0000    IN  
 ZMRP       1.3900    IN  
 SCALE      0.0055

REFERENCE FILE



# AEDC VA 1163 MDAC BOOSTER AND ORBITER TEST DATA AT MACH NUMBER 5

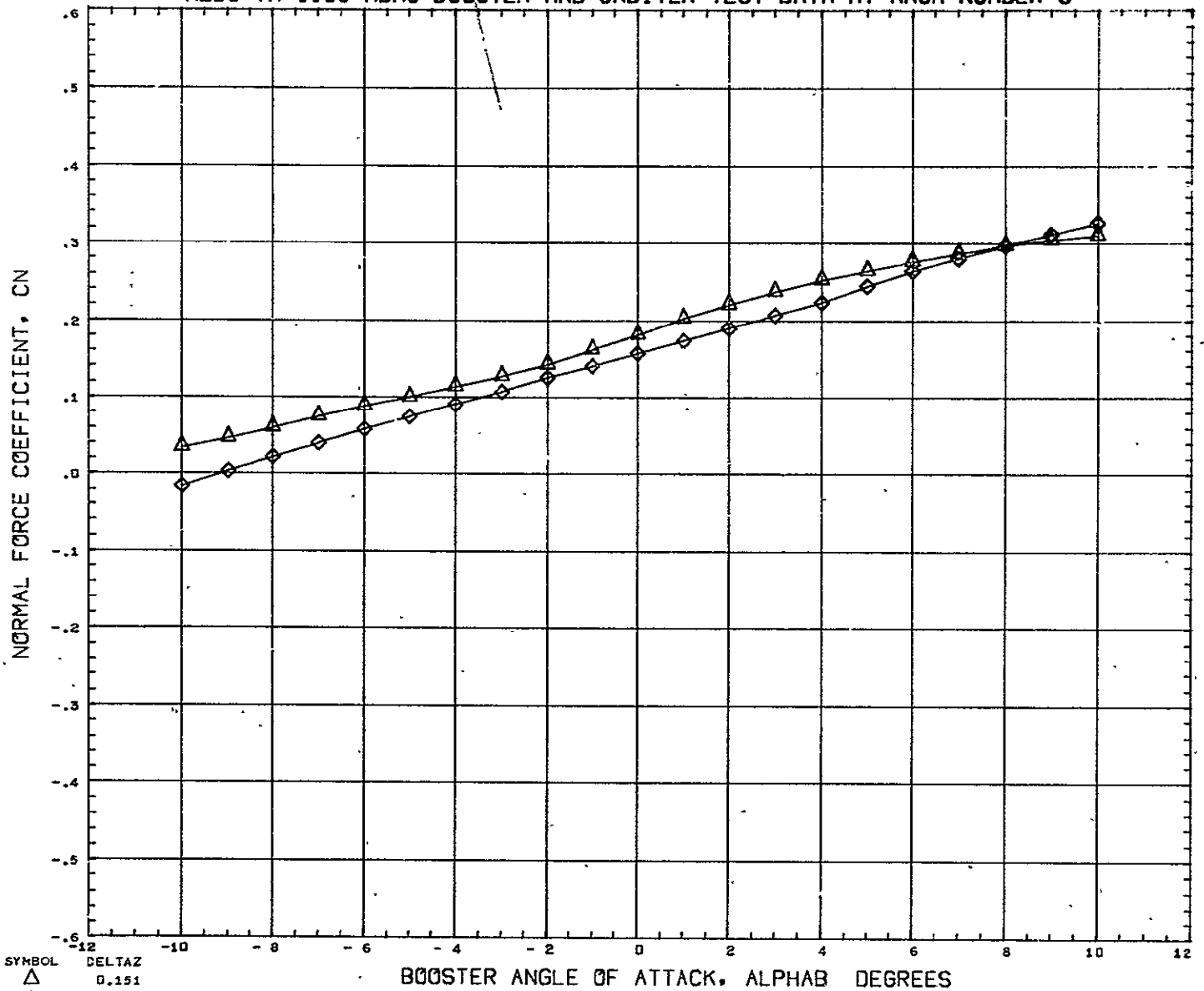

SYMBOL    DELTA Z  
 △        0.151  
 ◇        0.182

PARAMETRIC VALUES  
 BSTPOW    50.000    ORBPOW    25.000  
 DELTAX    0.104    ALPHAI    5.000  
 MACH      5.010    ELVBST    0.000  
 ELVORB    0.000    BETA      0.000

REFERENCE FILE

REFERENCE INFORMATION  
 REFS      23.6890    SQ IN  
 REFL      4.1930    IN  
 REFB      6.5000    IN  
 XMRP      4.9170    IN  
 YMRP      0.0000    IN  
 ZMRP      1.3900    IN  
 SCALE     0.0055

AEDC VA 1163 MDAC BOOSTER AND ORBITER TEST DATA AT MACH NUMBER 5

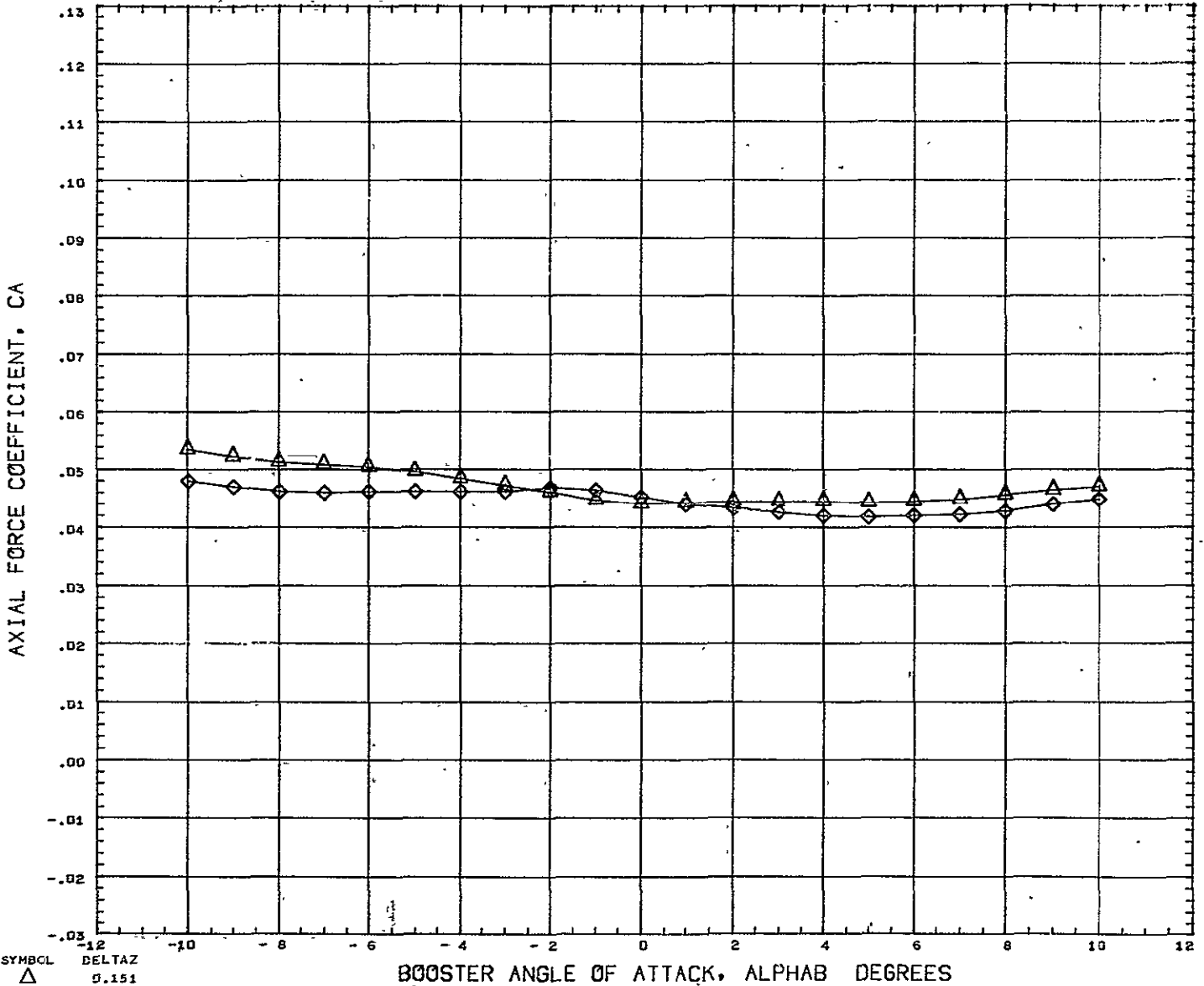

SYMBOL  
 △ DELTAX 0.151  
 ◇ DELTAX 0.182

PARAMETRIC VALUES  
 BSTFOW 50.000 ORBPOW 25.000  
 DELTAX 0.104 ALPHAI 5.000  
 MACH 5.010 ELVBST 0.000  
 ELVORB 0.000 BETA 0.000

REFERENCE INFORMATION  
 REFS 23.6890 SQ IN  
 REFL 4.1930 IN  
 REFB 6.5000 IN  
 XMRP 4.9170 IN  
 YMRP 0.0000 IN  
 ZMRP 1.3900 IN  
 SCALE 0.0055

REFERENCE FILE

# AEDC VA-1163 MDAC BOOSTER AND ORBITER TEST DATA AT MACH NUMBER 5

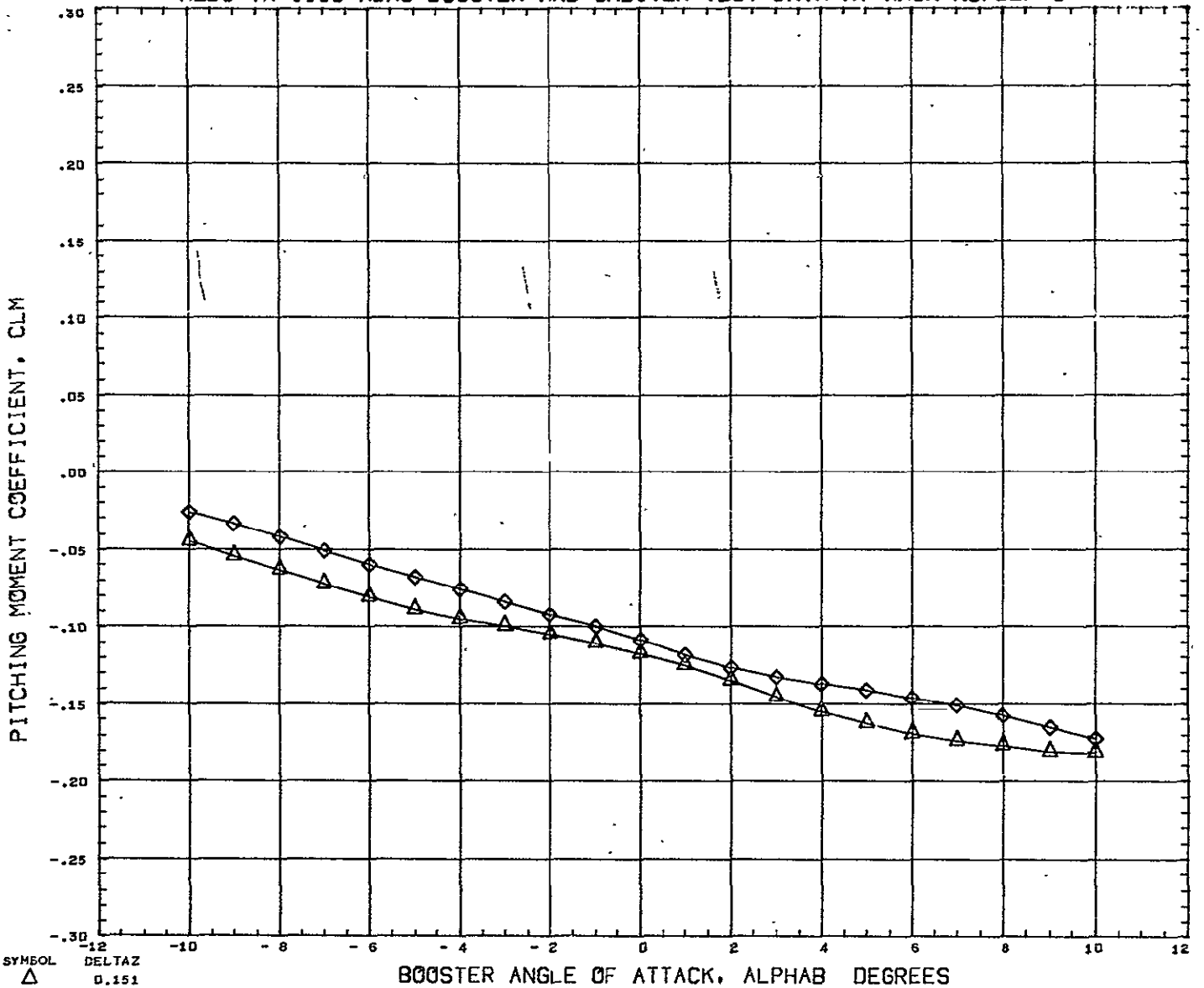

SYMBOL  
 △ DELTAZ 0.151  
 ◇ DELTAZ 0.182

PARAMETRIC VALUES  
 BSTPOW 50.000 ORBPOW 25.000  
 DELTAX 0.166 ALPHAI 5.000  
 MACH 5.010 ELVBST 0.000  
 ELVORB 0.000 BETA 0.000

REFERENCE INFORMATION  
 REFS 23.6890 SQ IN  
 REFL 4.1930 IN  
 REFB 6.5000 IN  
 XMRP 4.9170 IN  
 YMRP 0.0000 IN  
 ZMRP 1.3900 IN  
 SCALE 0.0055

REFERENCE FILE

AEDC VA 1163 MDAC BOOSTER AND ORBITER TEST DATA AT MACH NUMBER 5

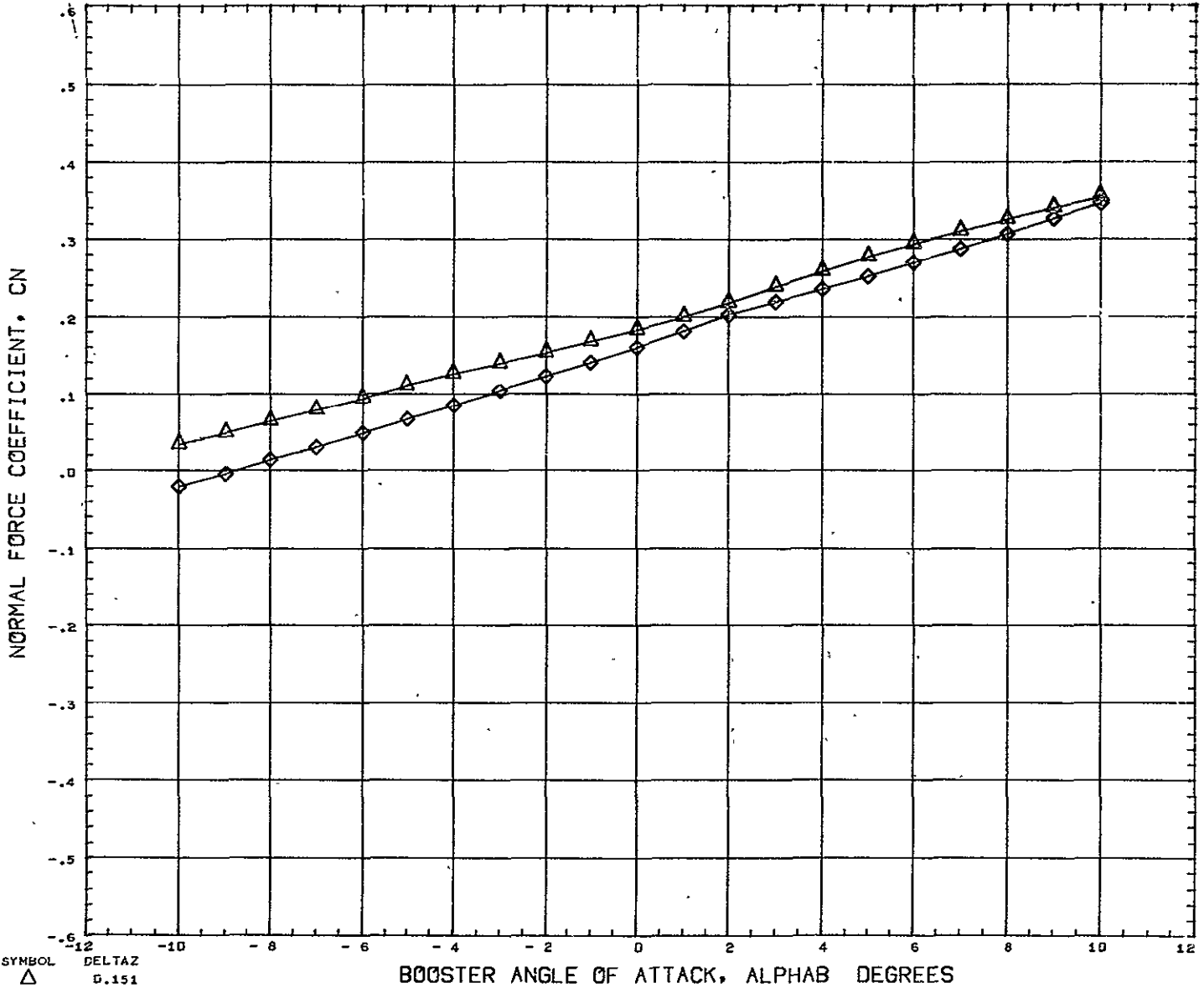

SYMBOL  $\Delta$  DELTA Z  
 $\diamond$  0.151  
 0.102

BOOSTER ANGLE OF ATTACK, ALPHAB DEGREES

PARAMETRIC VALUES  
 BSTPOW 50.000 ORBPOW 25.000  
 DELTAX 0.166 ALPHAI 5.000  
 MACH 5.010 ELVBST 0.000  
 ELVORB 0.000 BETA 0.000

REFERENCE INFORMATION  
 REFS 23.6890 SQ IN  
 REFL 4.1930 IN  
 REFB 6.5000 IN  
 XMRP 4.9170 IN  
 YMRP 0.0000 IN  
 ZMRP 1.3900 IN  
 SCALE 0.0055

REFERENCE FILE

# AEDC VA 1163 MDAC BOOSTER AND ORBITER TEST DATA AT MACH NUMBER 5

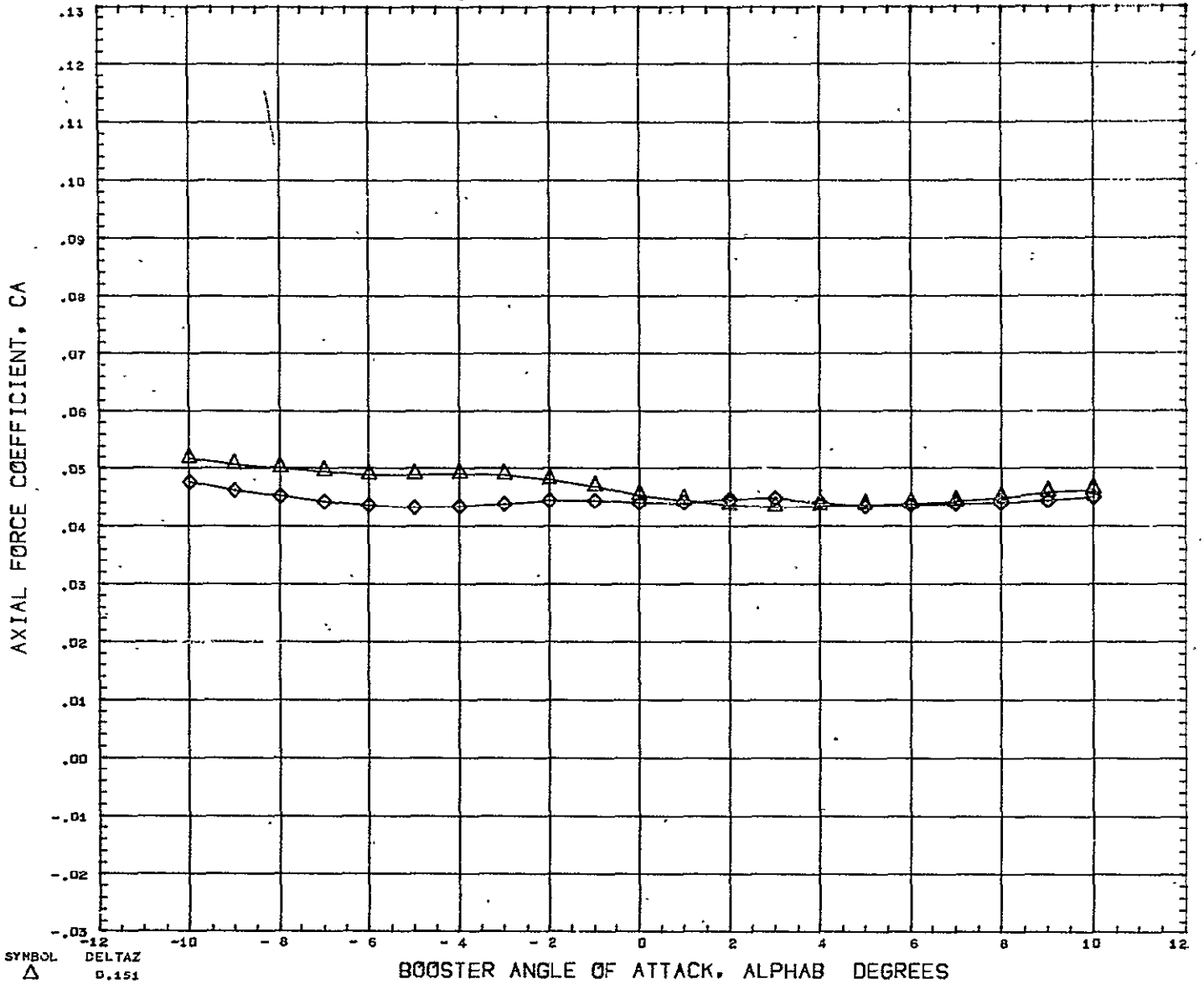

SYMBOL    DELTA Z  
 △        0.151  
 ◇        0.182

PARAMETRIC VALUES  
 9STPOW    50.000    ORBPOW    25.000  
 DELTAX    0.166    ALPHAI    5.000  
 MACH       5.010    ELVBST    0.000  
 ELVORB    0.000    BETA       0.000

REFERENCE INFORMATION  
 REFS       23.6890    SQ IN  
 REFL       4.1930    IN  
 REFB       6.5000    IN  
 XMRP       4.9170    IN  
 YMRP       0.0000    IN  
 ZMRP       1.3900    IN  
 SCALE       0.0055

REFERENCE FILE

# AEDC VA 1163 MDAC BOOSTER AND ORBITER TEST DATA AT MACH NUMBER 5

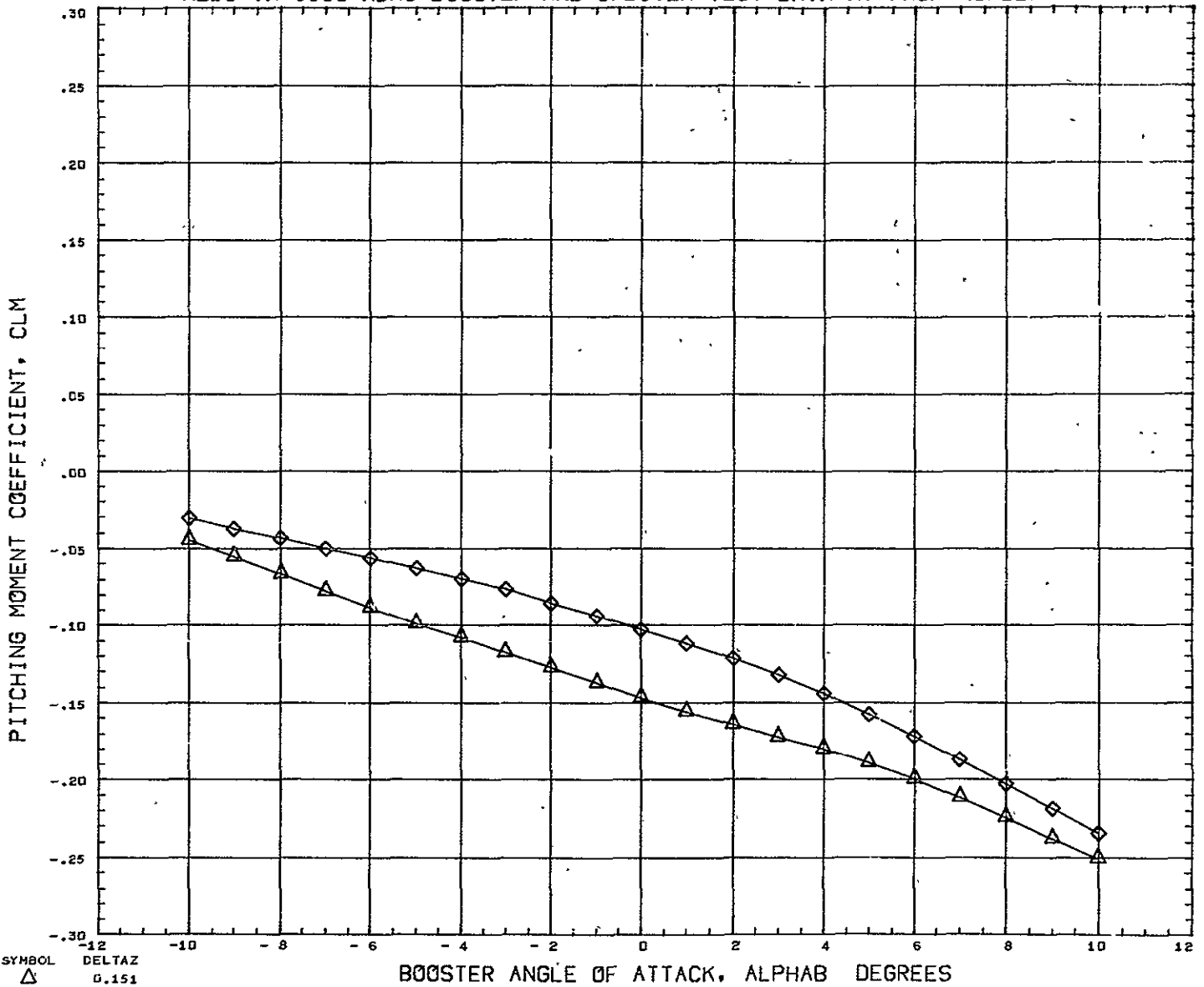

SYMBOL  $\triangle$  DELTA Z  
            $\diamond$  0.151  
            $\diamond$  0.182

### PARAMETRIC VALUES

BSTFOW	50.000	ORBPOW	25.000
DELTA X	0.351	ALPHA I	5.000
MACH	5.010	ELVBST	0.000
ELVORB	0.000	BETA	0.000

### REFERENCE INFORMATION

REFS	23.6890	SQ IN
REFL	4.1930	IN
REFB	6.5000	IN
XMRF	4.9170	IN
YMRF	0.0000	IN
ZMRF	1.3900	IN
SCALE	0.0055	

REFERENCE FILE

# AEDC VA 1163 MDAC BOOSTER AND ORBITER TEST DATA AT MACH NUMBER 5

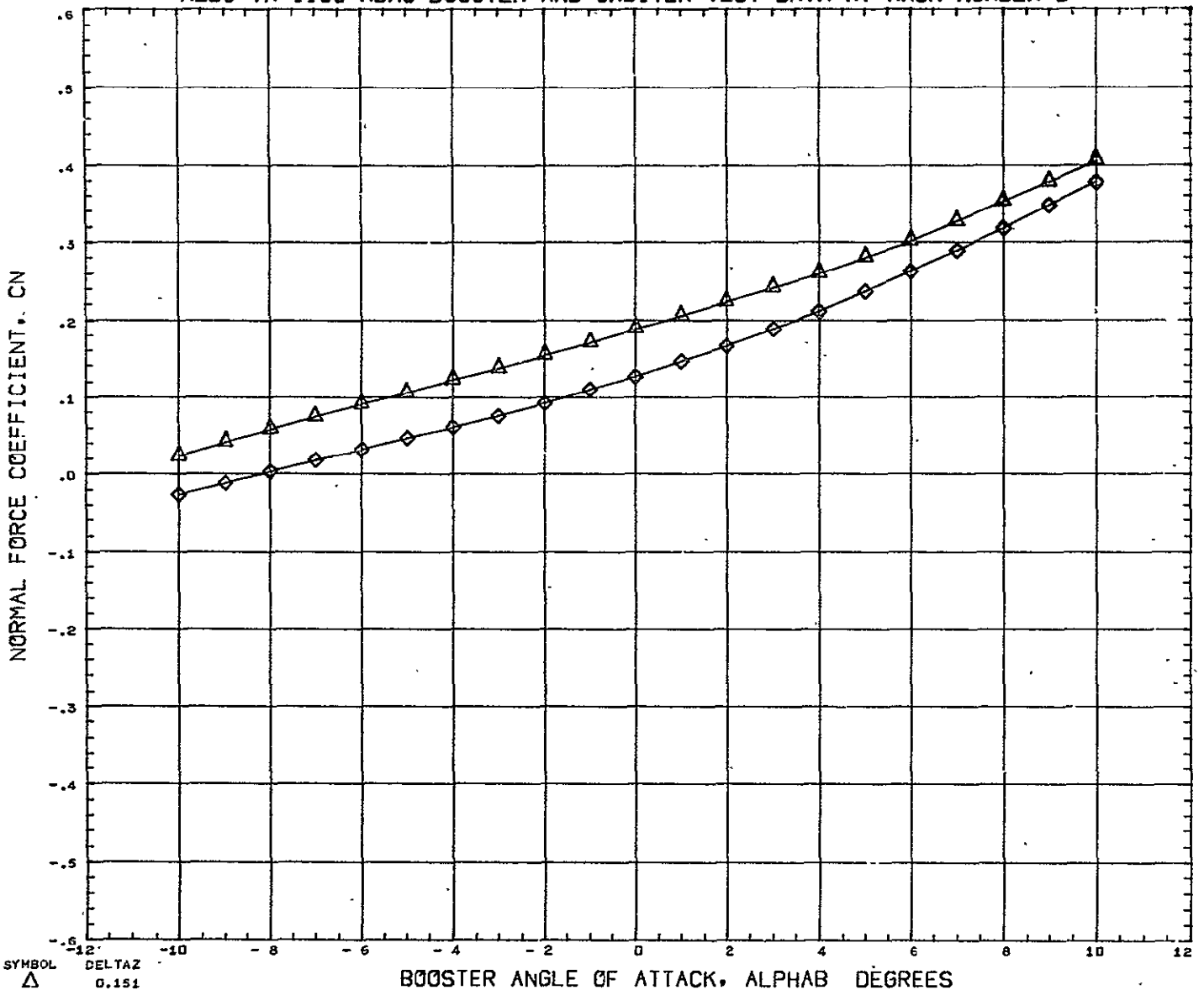

SYMBOL  $\Delta$  DELTA Z  
 $\diamond$  0.151  
 0.182

BOOSTER ANGLE OF ATTACK, ALPHA DEGREES

PARAMETRIC VALUES			
BSTPOW	50.000	ORBPOW	25.000
DELTA X	0.351	ALPHA I	5.000
MACH	5.010	ELVBST	0.000
ELVORB	0.000	BETA	0.000

REFERENCE INFORMATION		
REFS	23.6890	SQ IN
REFL	4.1930	IN
REFB	6.5960	IN
XHRF	4.9170	IN
YHRF	0.0000	IN
ZHRF	1.3900	IN
SCALE	0.0055	

REFERENCE FILE

# AEDC VA 1163 MDAC BOOSTER AND ORBITER TEST DATA AT MACH NUMBER 5

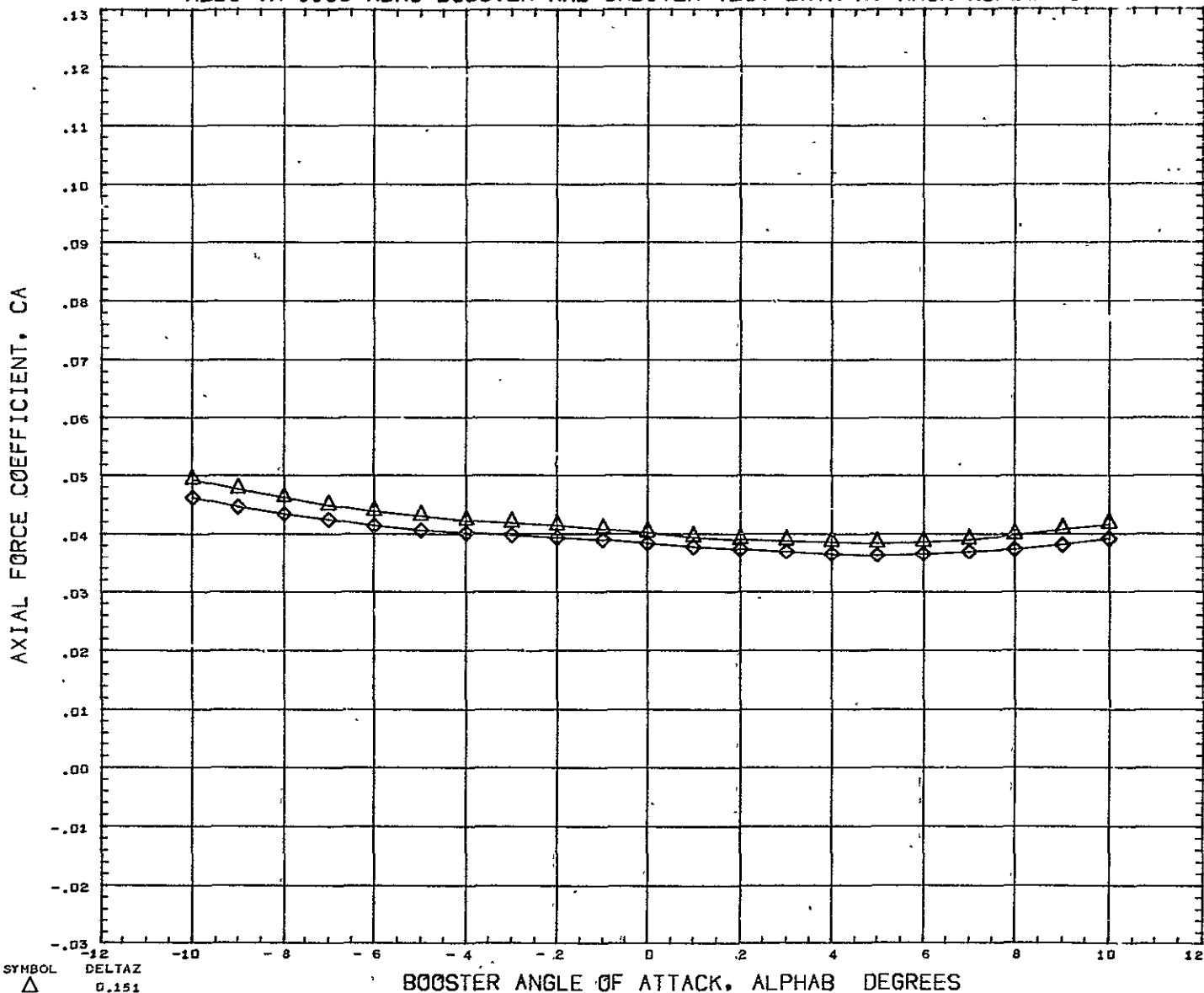

SYMBOL △ ◇	DELTA Z 0.151 0.182	<b>PARAMETRIC VALUES</b> BSTPOW    50.000    ORBPOW    25.000 DELTAX    0.351    ALPHAI    5.000 MACH      5.010    ELVBST    0.000 ELVORB    0.000    BETA      0.000	<b>REFERENCE INFORMATION</b> REFS      23.6890    SQ IN REFL      4.1930    IN REFB      6.5000    IN XMRP      4.9170    IN YMRP      0.0000    IN ZMRP      1.3900    IN SCALE     0.0055
REFERENCE FILE			



# AEDC VA 1163 MDAC BOOSTER AND ORBITER TEST DATA AT MACH NUMBER 5

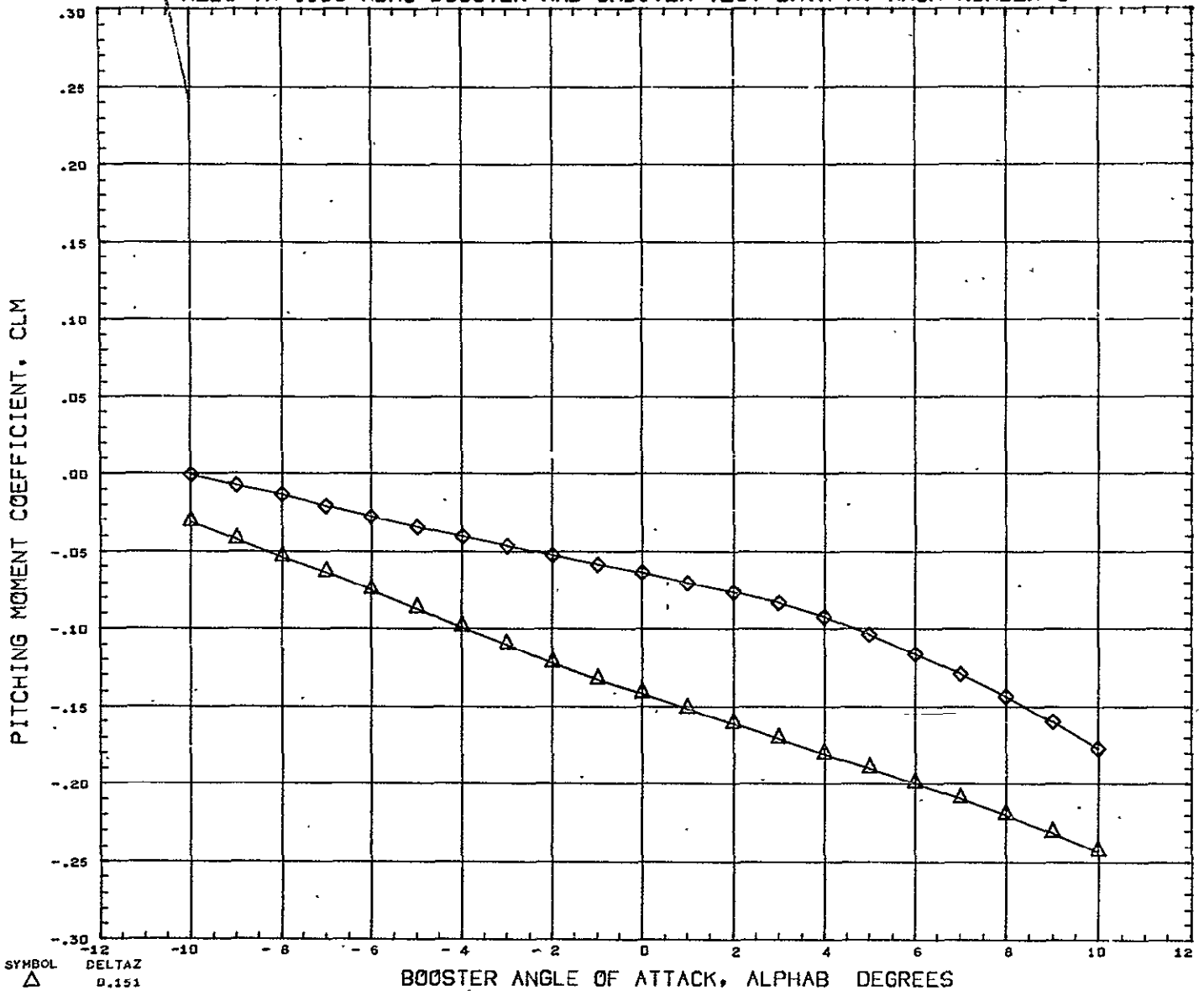

SYMBOL  
 △ DELTA Z  
 0.151  
 ◇ 0.182

BOOSTER ANGLE OF ATTACK, ALPHAB DEGREES

PARAMETRIC VALUES

BSTPOW	50.000	ORBPOW	25.000
DELTA Z	0.521	ALPHA I	5.000
MACH	5.010	ELVBST	0.000
ELVORB	0.000	BETA	0.000

REFERENCE INFORMATION

REFS	23.6890	SQ IN
REFL	4.1930	IN
REFB	6.5000	IN
XMRP	4.9170	IN
YMRP	0.0000	IN
ZMRP	1.3900	IN
SCALE	0.0055	

REFERENCE FILE

# AEDC VA 1163 MDAC BOOSTER AND ORBITER TEST DATA AT MACH NUMBER 5

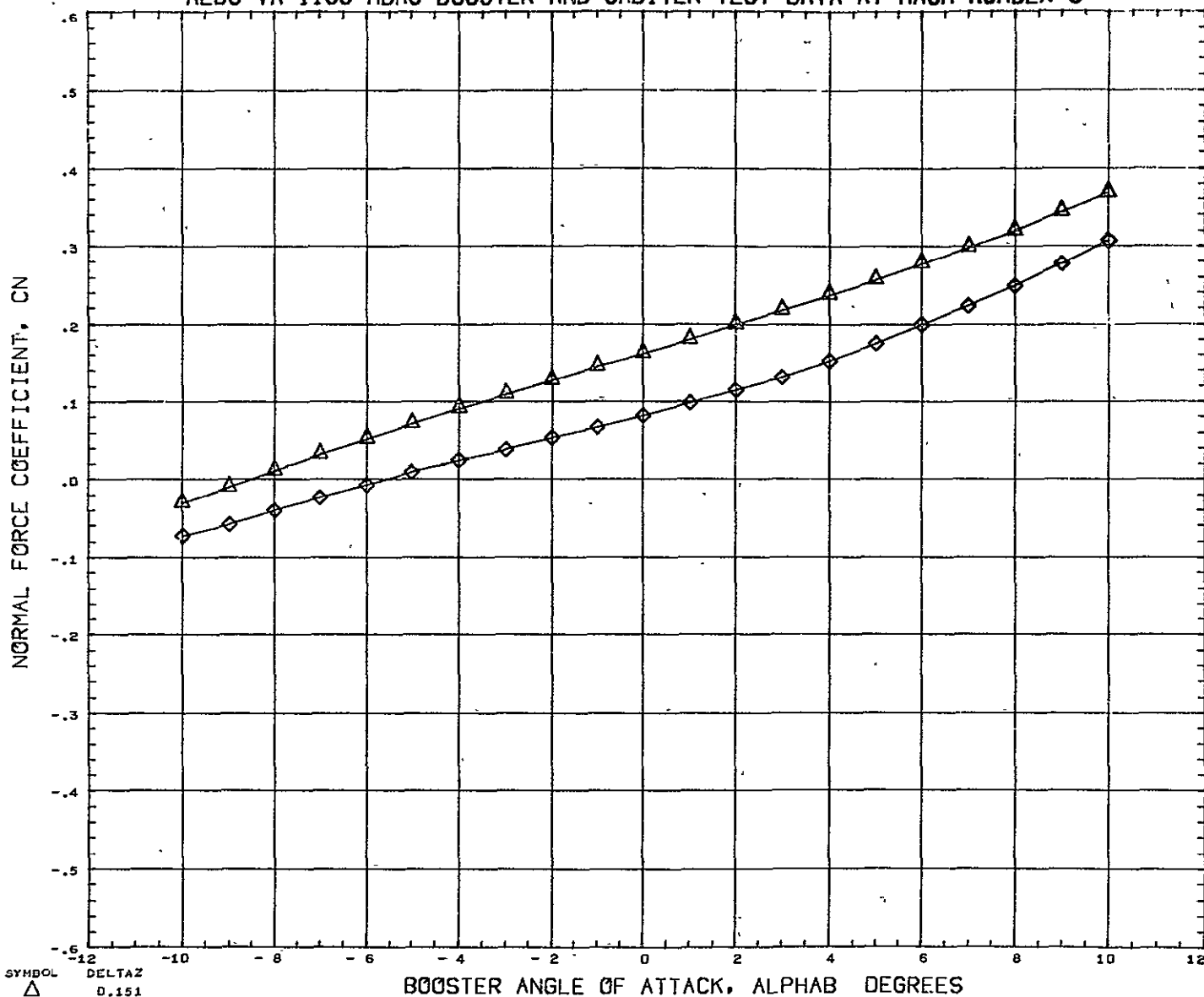

SYMBOL	△ DELTA Z 0.151 ◇ DELTA Z 0.182	<b>PARAMETRIC VALUES</b> BSTPOW    50.000    ORBPOW    25.000 DELTAX    0.521    ALPHAI    5.000 MACH      5.010    ELVBST    0.000 ELVORB    0.000    BETA      0.000	<b>REFERENCE INFORMATION</b> REFS      23.6890    SQ IN REFL      4.1930    IN REFB      6.5000    IN XMRP      4.9170    IN YMRP      0.0000    IN ZMRP      1.3900    IN SCALE     0.0055
REFERENCE FILE			

# AEDC VA 1163 MDAC BOOSTER AND ORBITER TEST DATA AT MACH NUMBER 5

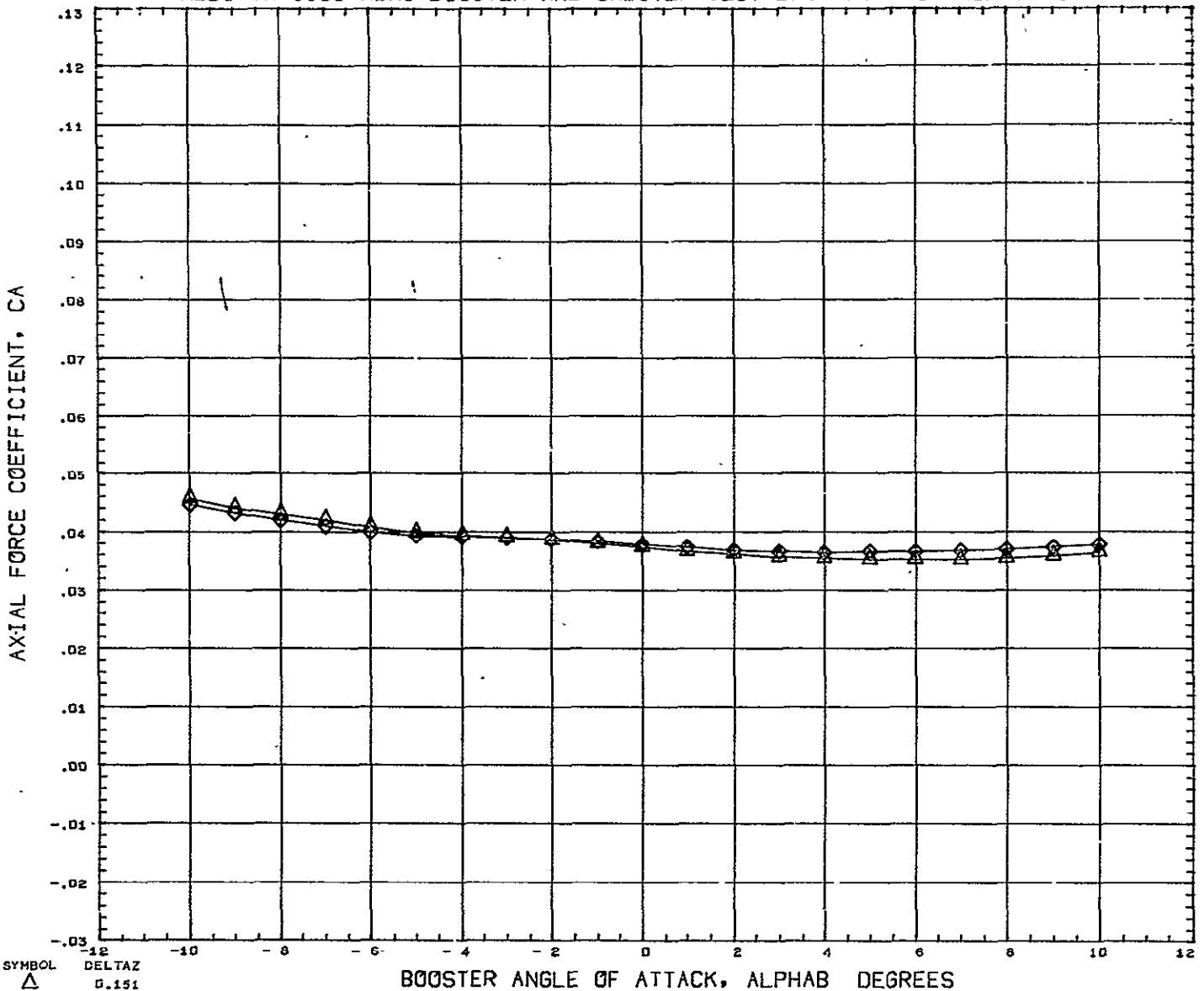

SYMBOL	DELTA Z	PARAMETRIC VALUES		REFERENCE INFORMATION	
△	0.151	BSTPOW	50.000	ORBPOW	25.000
◇	0.182	DELTA X	0.521	ALPHA I	5.000
		MACH	5.010	ELVBST	0.000
		ELVORB	0.000	BETA	0.000
				REFS	23.6890 SQ IN
				REFL	4.1930 IN
				REFB	6.5000 IN
				XMRP	4.9170 IN
				YMRP	0.0000 IN
				ZMRP	1.3900 IN
				SCALE	0.0055
		REFERENCE FILE			



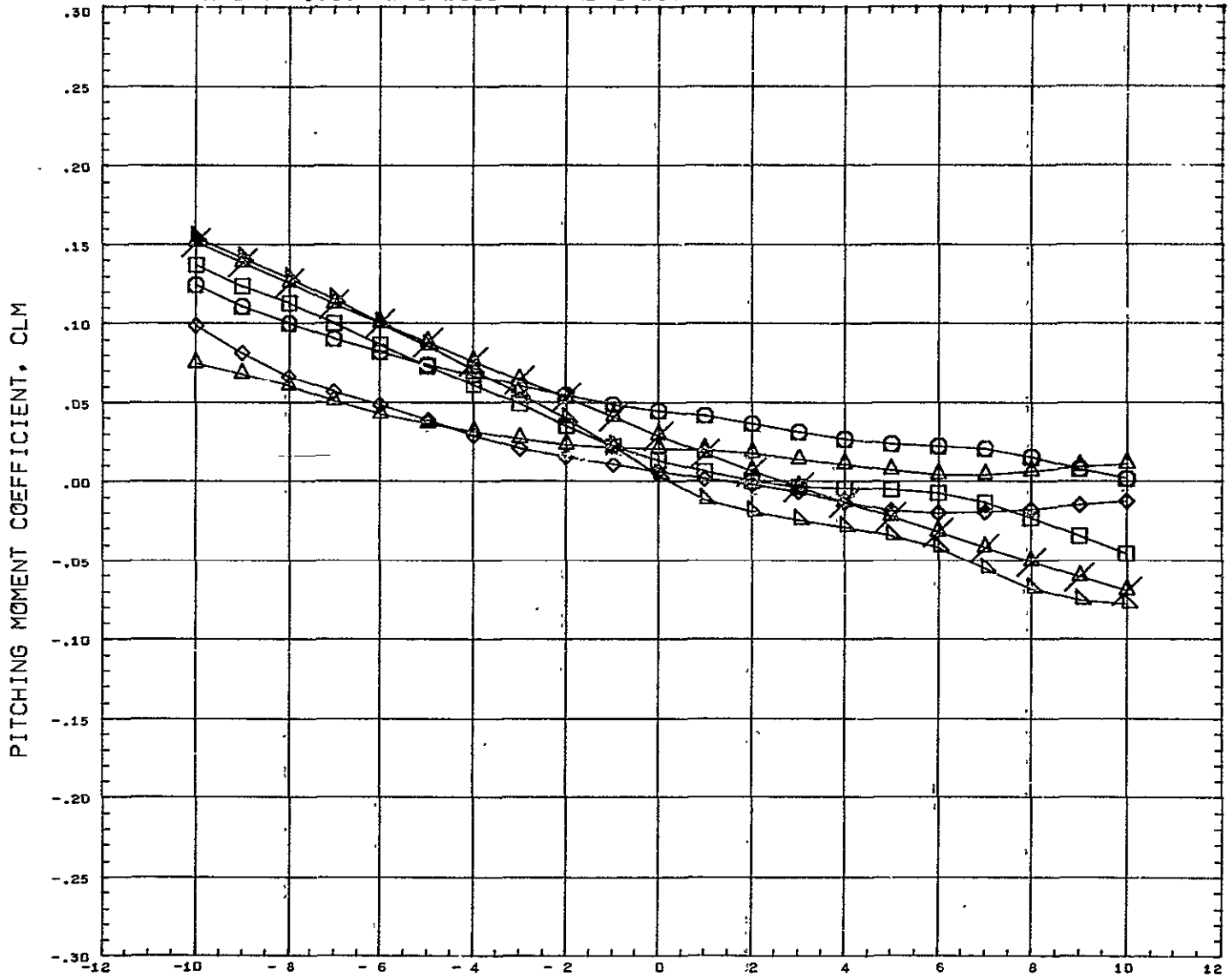

# AEDC VA 1163 MDAC BOOSTER AND ORBITER TEST DATA AT MACH NUMBER 5

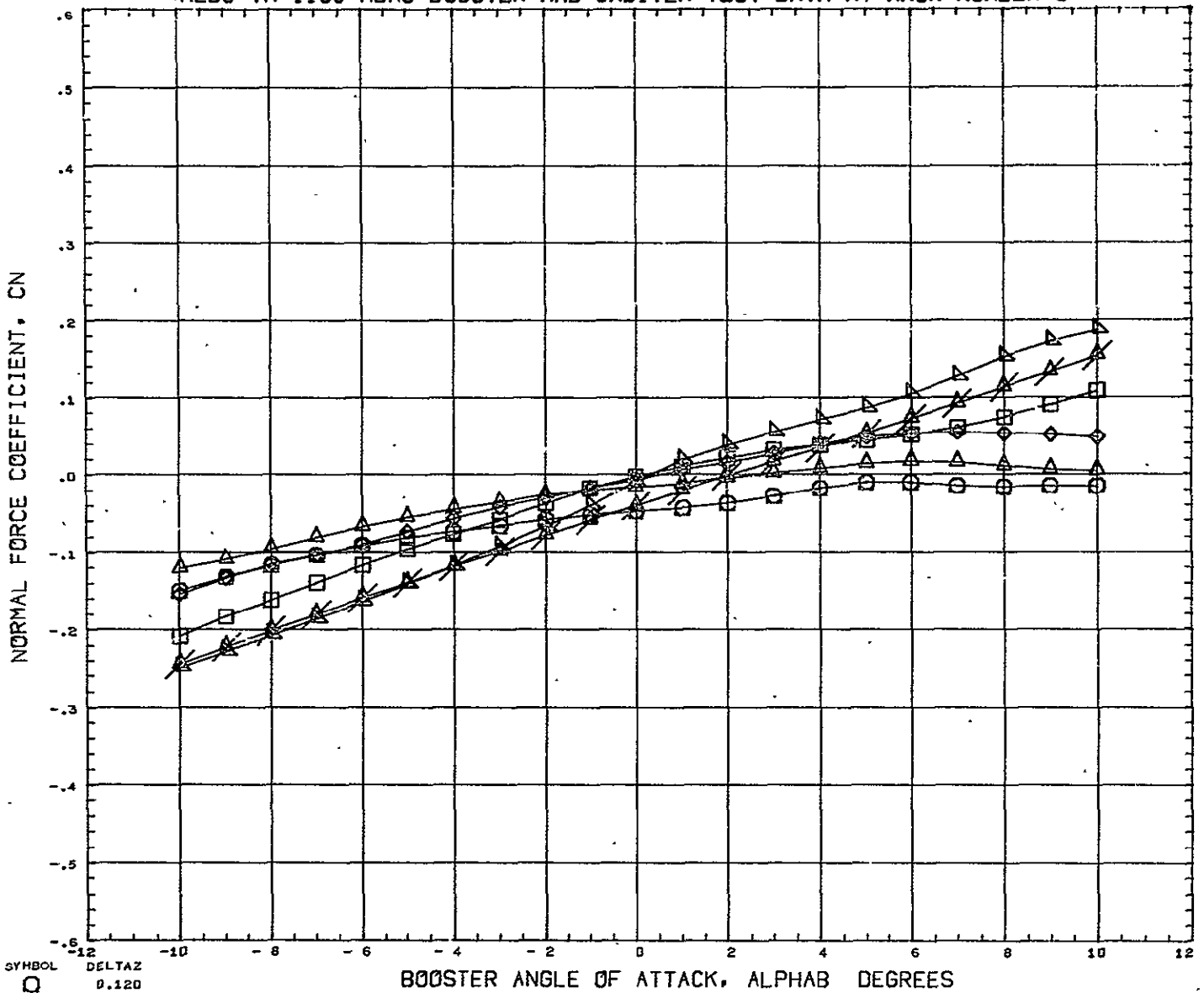

SYMBOL ○ □ △ ◇ ×	DELTAZ 0.120 0.151 0.182 0.228 0.352 10.000	PARAMETRIC VALUES BSTFOW    0.000    ORBPOW    0.000 DELTAX    - 0.391    ALPHAI    0.000 MACH       5.010    ELVBST    20.000 ELVORB    - 20.000    BETA       0.000	REFERENCE INFORMATION REFS       23.6890    SQ IN REFL       4.1930    IN REFB       6.5000    IN XMRP       4.9170    IN YHRF       0.0000    IN ZMRP       1.3900    IN SCALE       0.0055
REFERENCE FILE			

# AEDC VA 1163 MDAC BOOSTER AND ORBITER TEST DATA AT MACH NUMBER 5



SYMBOL  
  
  
  

DELTA Z  
 0.120  
 0.151  
 0.182  
 0.228  
 0.352  
 10.000

PARAMETRIC VALUES

BSTPOW	0.000	ORBPOW	0.000
DELTA X	-0.391	ALPHA I	0.000
MACH	5.010	ELVBST	20.000
ELVORB	-20.000	BETA	0.000

REFERENCE INFORMATION

REFS	23.6090	SQ	IN
REFL	4.1930	IN	
REFB	6.5000	IN	
XMRP	4.9170	IN	
YMRP	0.0000	IN	
ZMRP	1.3900	IN	
SCALE	0.0055		

REFERENCE FILE

# AEDC VA 1163 MDAC BOOSTER AND ORBITER TEST DATA AT MACH NUMBER 5

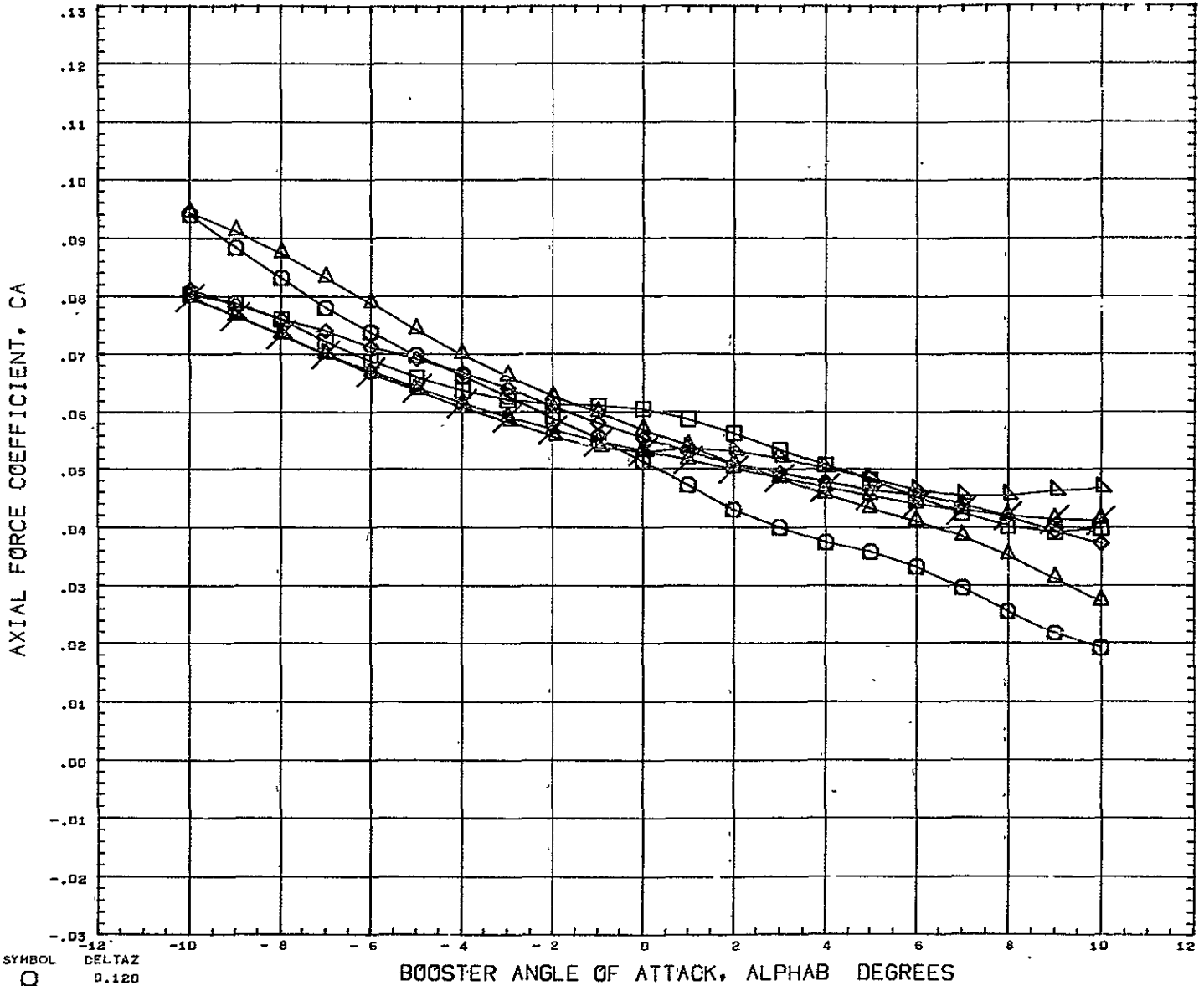

SYMBOL 	DELTAZ 0.120 0.151 0.182 0.228 0.352 10.000	<b>PARAMETRIC VALUES</b> BSTPOW    0.000    ORBPOW    0.000 DELTAX    - 0.391    ALPHAI    0.000 MACH       5.010    ELVBST    20.000 ELVORB    - 20.000    BETA       0.000	<b>REFERENCE INFORMATION</b> REFS       23.6890    SQ IN REFL       4.1930    IN REFB       6.5000    IN XMRP       4.9170    IN YMRP       0.0000    IN ZMRP       1.3900    IN SCALE      0.0055
REFERENCE FILE			

# AEDC VA 1163 MDAC BOOSTER AND ORBITER TEST DATA AT MACH NUMBER 5

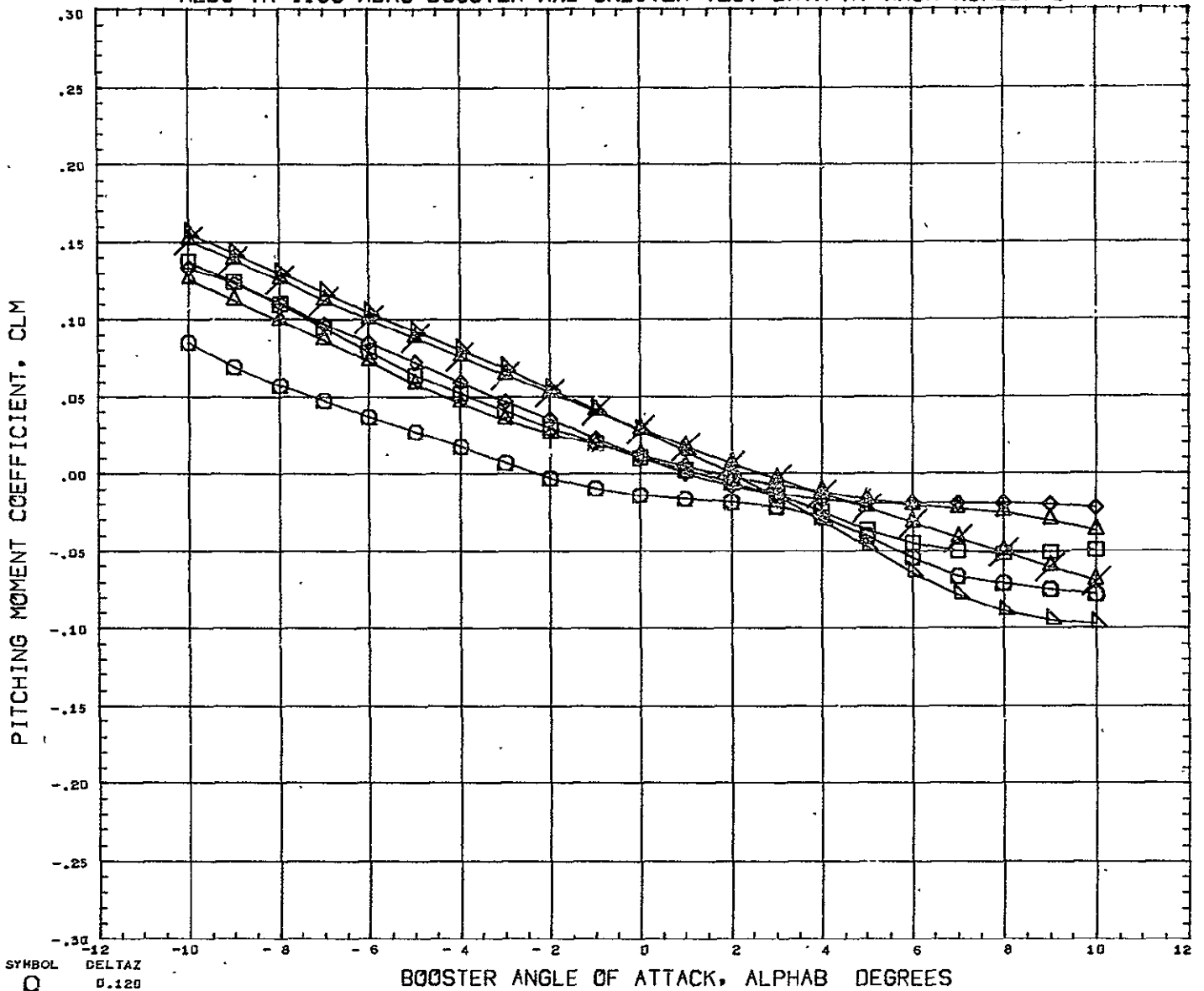

SYMBOL ○ □ △ ◇ ×	DELTAX 0.120 0.151 0.182 0.228 0.352 10.000	<table border="0" style="width: 100%;"> <tr> <th colspan="4" style="text-align: center;">PARAMETRIC VALUES</th> </tr> <tr> <td>BSTPOW</td> <td>0.000</td> <td>ORBPOW</td> <td>0.000</td> </tr> <tr> <td>DELTAI</td> <td>- 0.143</td> <td>ALPHAI</td> <td>0.000</td> </tr> <tr> <td>MACH</td> <td>5.010</td> <td>ELVBST</td> <td>20.000</td> </tr> <tr> <td>ELVORB</td> <td>- 20.000</td> <td>BETA</td> <td>0.000</td> </tr> </table>	PARAMETRIC VALUES				BSTPOW	0.000	ORBPOW	0.000	DELTAI	- 0.143	ALPHAI	0.000	MACH	5.010	ELVBST	20.000	ELVORB	- 20.000	BETA	0.000	<table border="0" style="width: 100%;"> <tr> <th colspan="3" style="text-align: center;">REFERENCE INFORMATION</th> </tr> <tr> <td>REFS</td> <td>23.6890</td> <td>SQ IN</td> </tr> <tr> <td>REFL</td> <td>4.1930</td> <td>IN</td> </tr> <tr> <td>REFB</td> <td>6.5500</td> <td>IN</td> </tr> <tr> <td>XMRP</td> <td>4.9170</td> <td>IN</td> </tr> <tr> <td>YMRP</td> <td>0.0000</td> <td>IN</td> </tr> <tr> <td>ZMRP</td> <td>1.3900</td> <td>IN</td> </tr> <tr> <td>SCALE</td> <td>0.0055</td> <td></td> </tr> </table>	REFERENCE INFORMATION			REFS	23.6890	SQ IN	REFL	4.1930	IN	REFB	6.5500	IN	XMRP	4.9170	IN	YMRP	0.0000	IN	ZMRP	1.3900	IN	SCALE	0.0055	
PARAMETRIC VALUES																																															
BSTPOW	0.000	ORBPOW	0.000																																												
DELTAI	- 0.143	ALPHAI	0.000																																												
MACH	5.010	ELVBST	20.000																																												
ELVORB	- 20.000	BETA	0.000																																												
REFERENCE INFORMATION																																															
REFS	23.6890	SQ IN																																													
REFL	4.1930	IN																																													
REFB	6.5500	IN																																													
XMRP	4.9170	IN																																													
YMRP	0.0000	IN																																													
ZMRP	1.3900	IN																																													
SCALE	0.0055																																														

REFERENCE FILE

# AEDC VA 1163 MDAC BOOSTER AND ORBITER TEST DATA AT MACH NUMBER 5

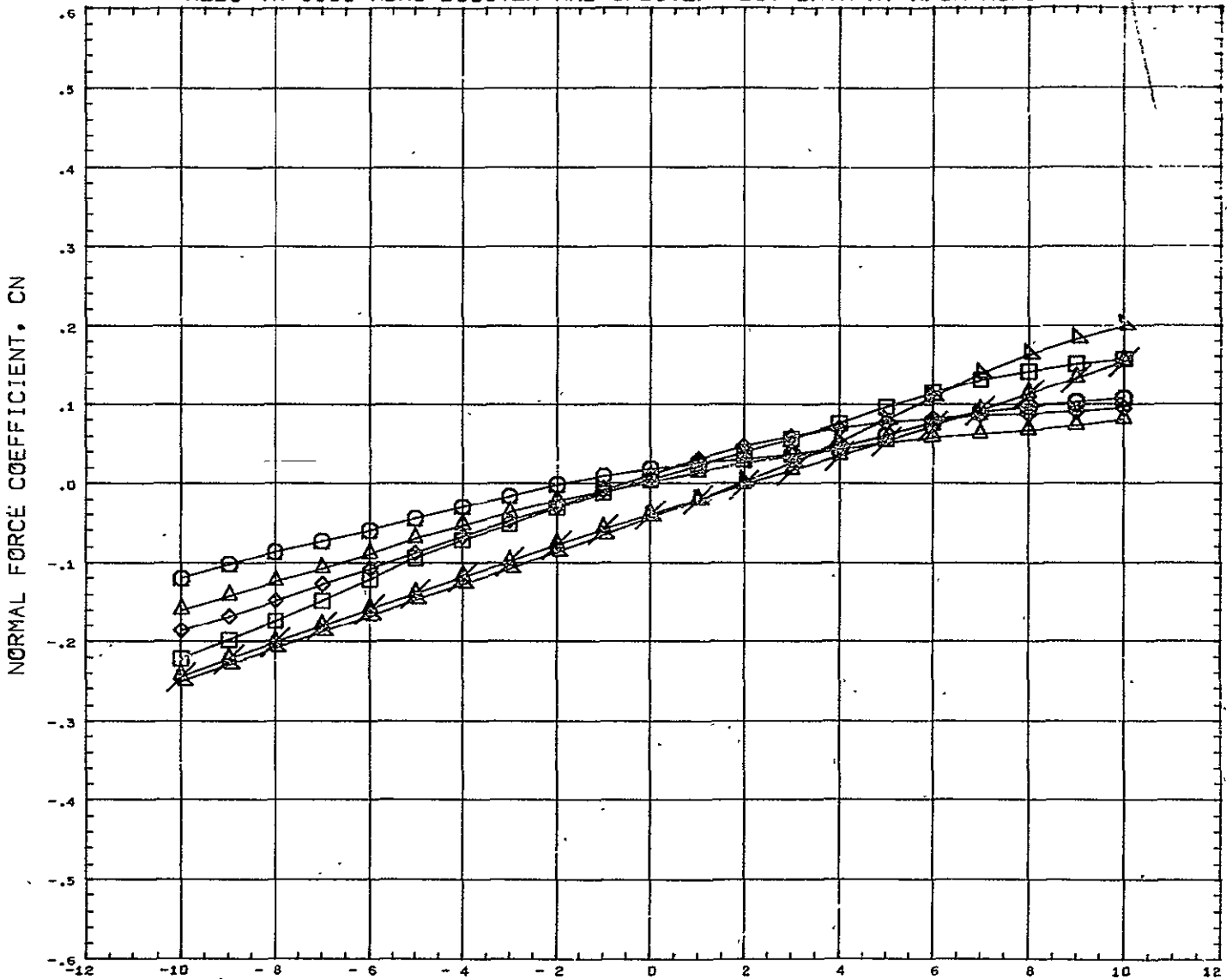

SYMBOL ○ ◊ □ △	DELTA Z 0.126 0.151 0.182 0.228 0.352 10.000	PARAMETRIC VALUES BSTPOW    0.000    ORBPOW    0.000 DELTAX    - 0.143    ALPHAI    0.000 MACH       5.010    ELVBST    20,000 ELVORB    - 20.000    BETA       0.000	REFERENCE INFORMATION REFS       23.6890    SQ IN REFL       4.1930    IN REFB       6.5000    IN XMRP       4.9170    IN YMRP       0.0000    IN ZMRP       1.3900    IN SCALE       0.0055
REFERENCE FILE			



# AEDC VA 1163 MDAC BOOSTER AND ORBITER TEST DATA AT MACH NUMBER 5

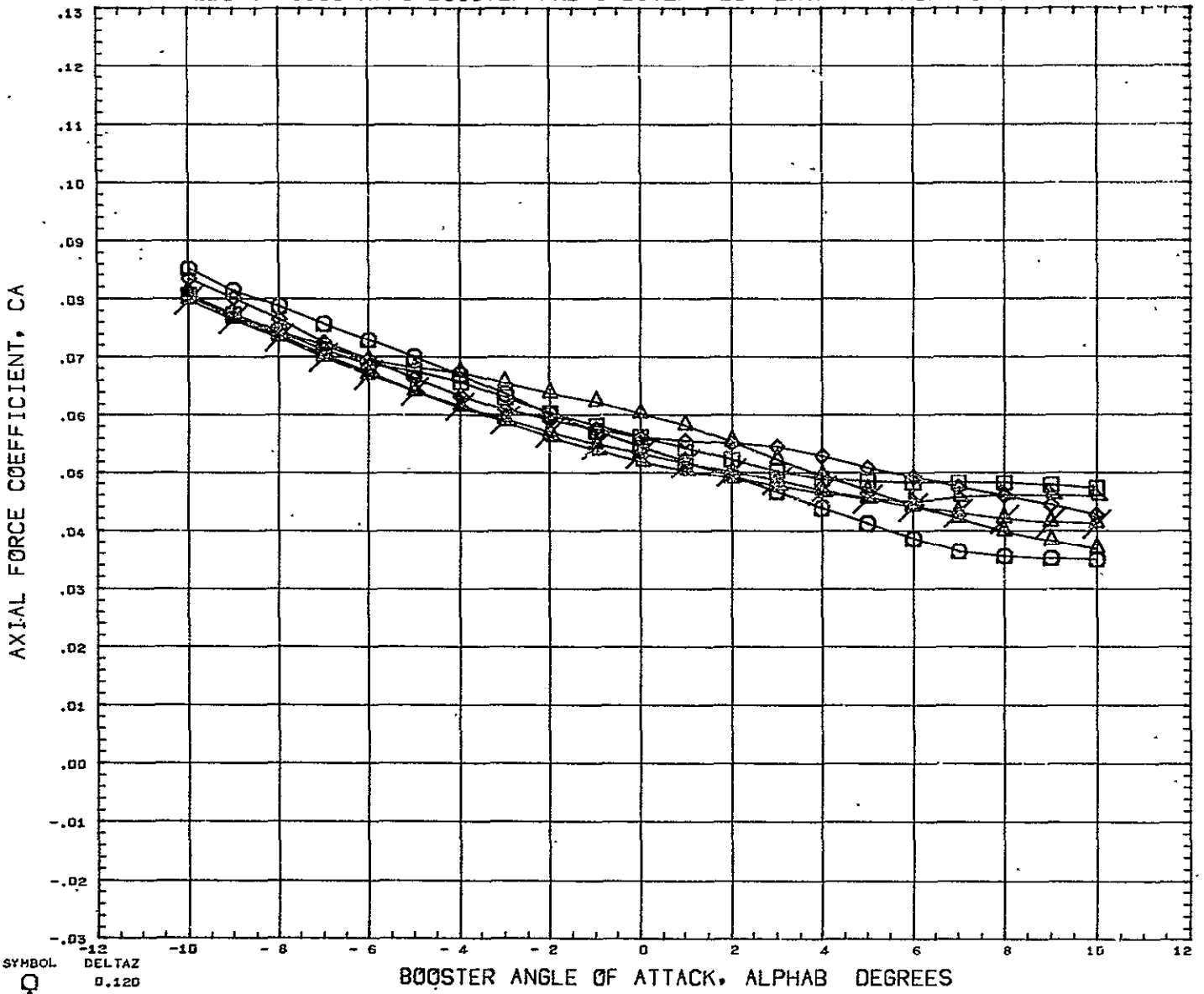

SYMBOL ○ △ ◇ □ × ▲	DELTAZ 0.120 0.151 0.182 0.228 0.352 10.000	PARAMETRIC VALUES BSTPOW    0.000    ORBPOW    0.000 DELTAX    - 0.143    ALPHA1    0.000 MACH       5.010    ELVBST    20.000 ELVORB    - 20.000    BETA       0.000	REFERENCE INFORMATION REFS       23.6890    3Q IN REFL       4.1930    IN REFB       6.5000    IN XMRP       4.9170    IN YMRP       0.0000    IN ZMRP       1.3900    IN SCALE       0.0055
--------------------------------------	---	---	---

REFERENCE FILE

# AEDC VA 1163 MDAC BOOSTER AND ORBITER TEST DATA AT MACH NUMBER 5

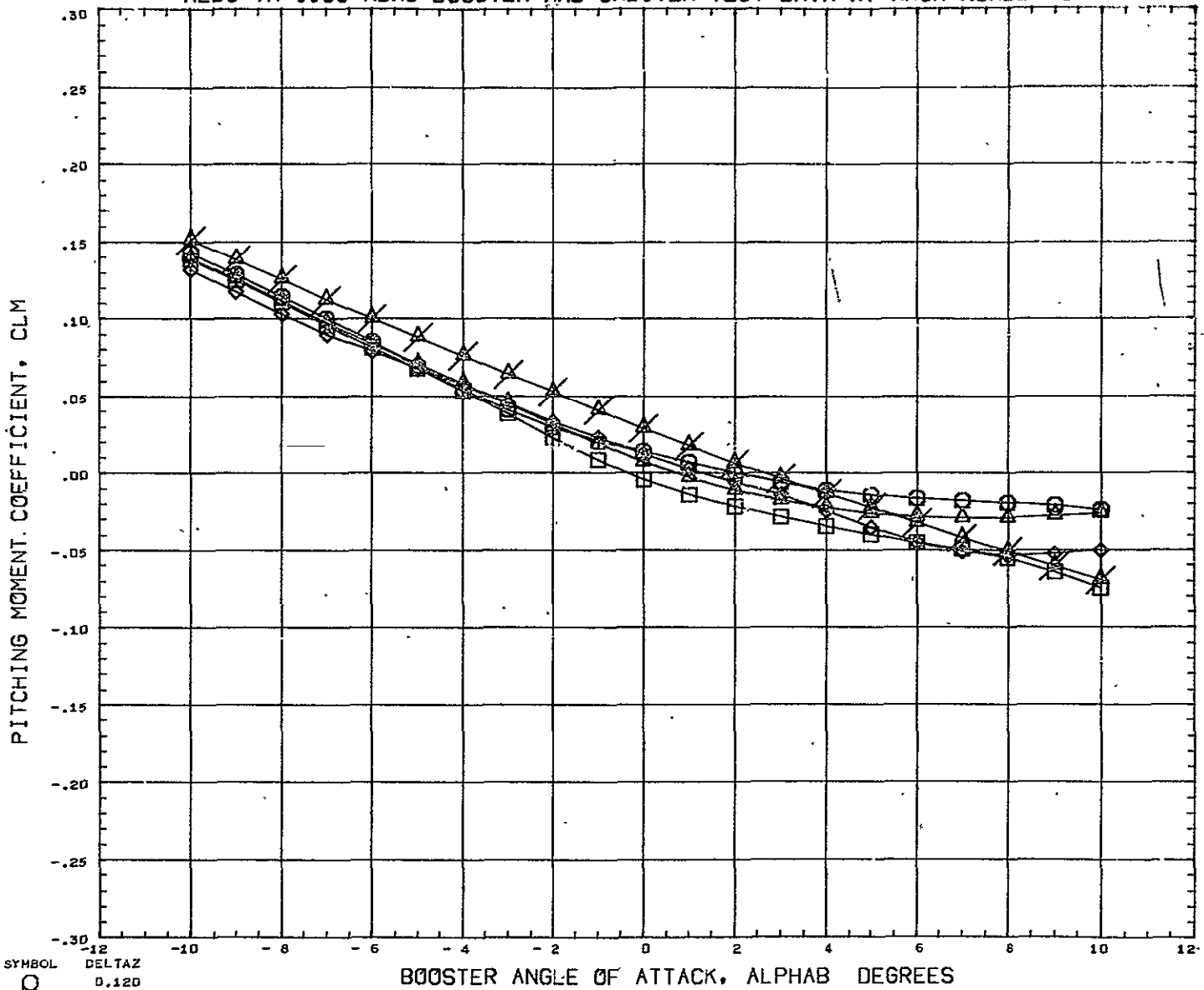

SYMBOL	DELTA Z	PARAMETRIC VALUES				REFERENCE INFORMATION		
○	0.120	BSTPOW	0.000	ORBPOW	0.000	REFS	23.6890	SQ IN
◇	0.151	DELTA X	- 0.019	ALPHA I	0.000	REFL	4.1930	IN
□	0.228	MACH	5.010	ELVBST	20.000	REFD	6.5000	IN
△	10.000	ELVORB	- 20.000	BETA	0.000	XMRP	4.9170	IN
×						YMRP	0.0000	IN
						ZMRP	1.3900	IN
						SCALE	0.0055	

REFERENCE FILE

# AEDC VA 1163 MDAC BOOSTER AND ORBITER TEST DATA AT MACH NUMBER 5

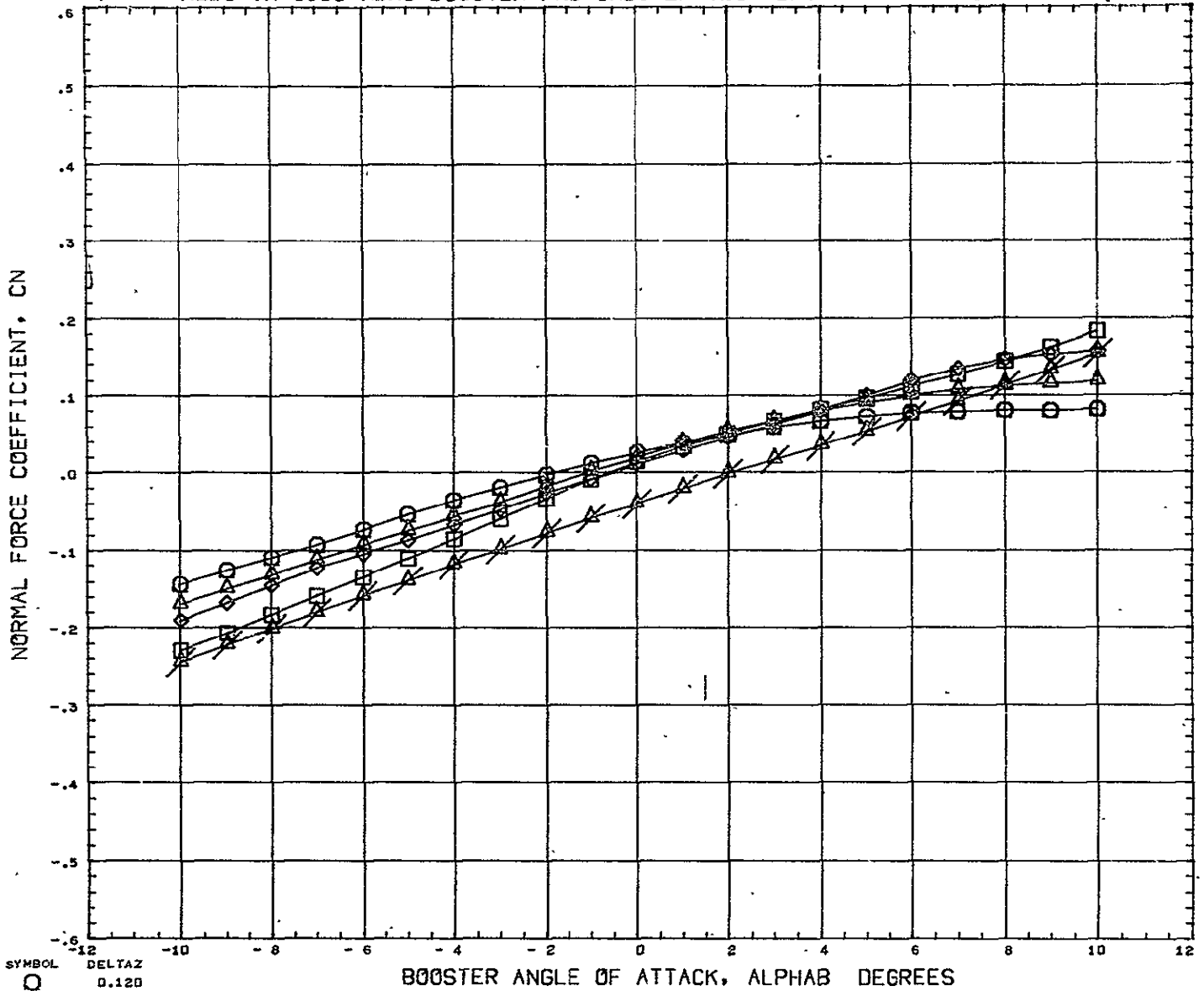

SYMBOL  
 ○  
 ◇  
 □  
 △  
 ×

DELTAZ  
 0.120  
 0.151  
 0.182  
 0.228  
 10.000

PARAMETRIC VALUES

BSTPOW	-0.000	ORBPOW	0.000
DELTAZ	0.019	ALPHA1	0.000
MACH	5.010	ELVBST	20.300
ELVORB	-20.000	BETA	0.000

REFERENCE INFORMATION

REFS	23.6890	SQ IN
REFL	4.1930	IN
REFB	6.5000	IN
XMRP	4.9175	IN
YHRP	0.0000	IN
ZHRP	1.3900	IN
SCALE	0.0055	

REFERENCE FILE

# AEDC VA 1163 MDAC BOOSTER AND ORBITER TEST DATA AT MACH NUMBER 5

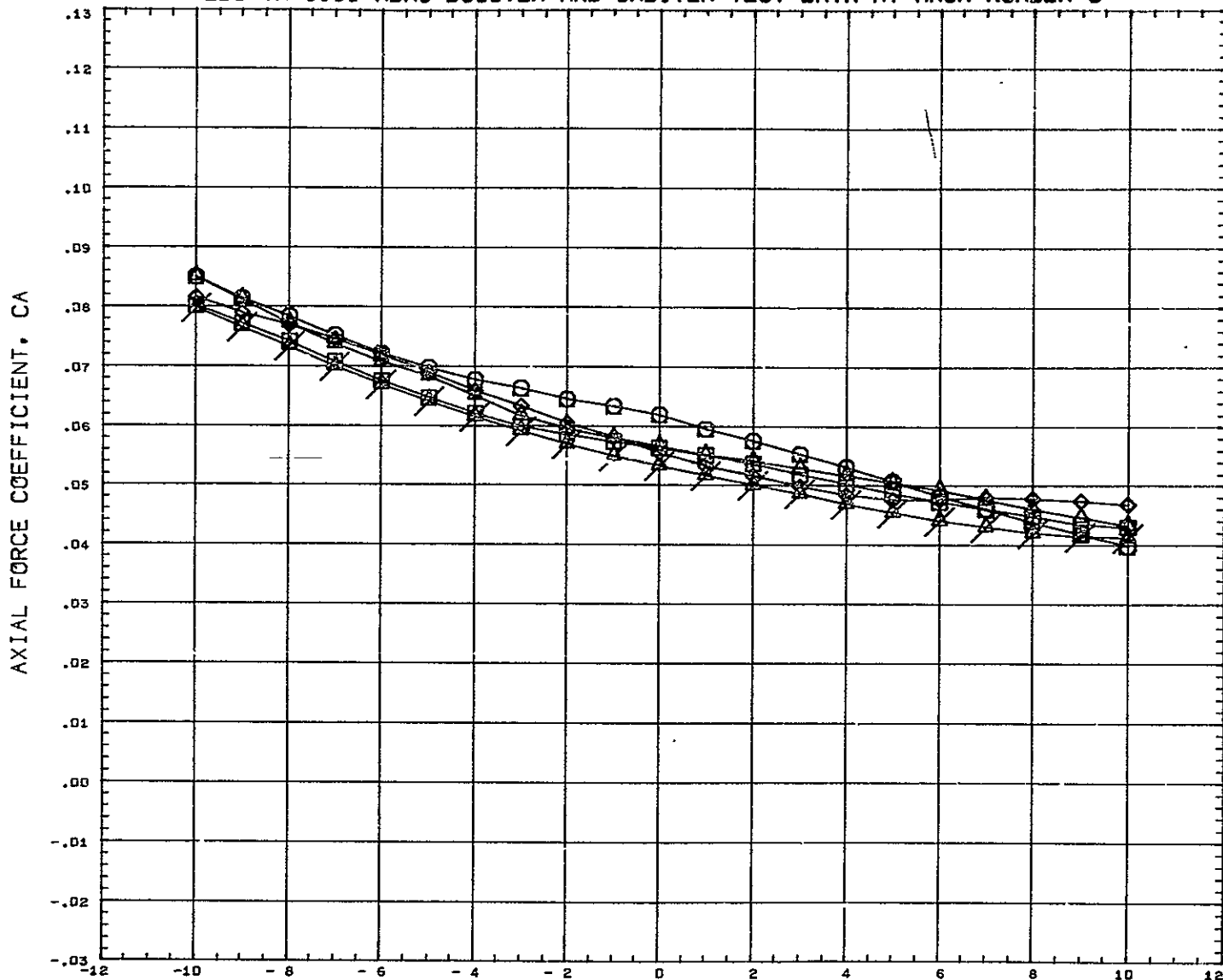

SYMBOL ○ △ ◇ □ ×	DELTAZ 0.120 0.151 0.182 0.228 10.000	PARAMETRIC VALUES BSTPOW    0.000    ORBPOW    0.000 DELTAX   - 0.019    ALPHAI    0.000 MACH      5.010    ELVBST    20.000 ELVORB   - 20.000    BETA      0.000	REFERENCE INFORMATION REFS      23.6890    SQ IN REFL      4.1930    IN REFB      6.5000    IN XMRF      4.9170    IN YMRP      0.0000    IN ZMRP      1.3900    IN SCALE     0.0055
REFERENCE FILE			

# AEDC VA 1163 MDAC BOOSTER AND ORBITER TEST DATA AT MACH NUMBER 5

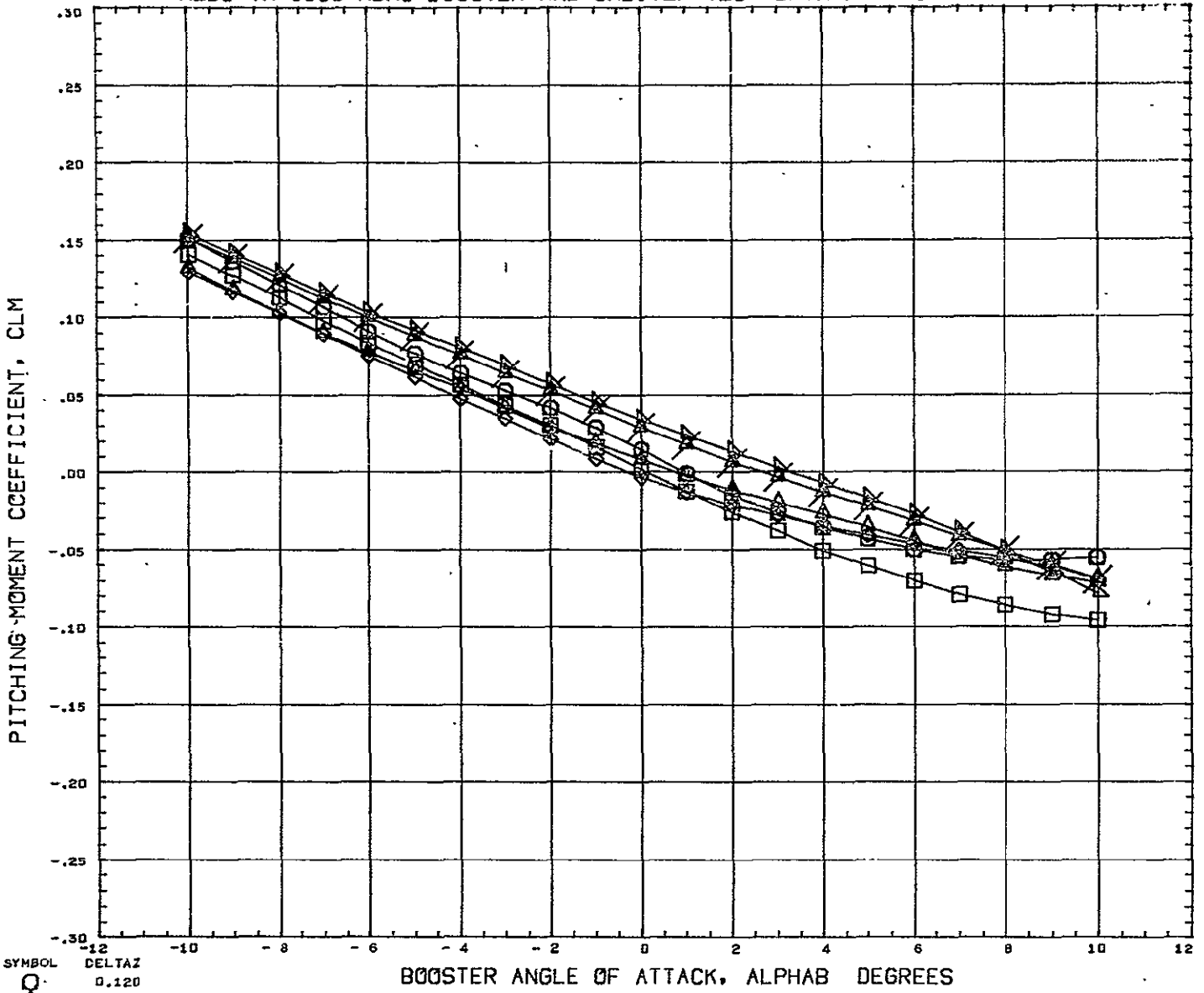

SYMBOL ○ □ △ × ◇	DELTA Z 0.120 0.154 0.182 0.228 0.352 10.000	<b>PARAMETRIC VALUES</b> BSTPOW    0.000    ORBPOW    0.000 DELTAX    0.104    ALPHA1    0.000 MACH       5.010    ELVBST    20.000 ELVORB    -20.000    BETA       0.000	<b>REFERENCE INFORMATION</b> REFS       23.6890    SQ IN REFL       4.1930    IN REFB       6.5000    IN XMRP       4.9170    IN YMRP       0.0000    IN ZMRP       1.3900    IN SCALE       0.0055
---------------------------------	--	---	--

REFERENCE FILE

# AEDC VA 1163 MDAC BOOSTER AND ORBITER TEST DATA AT MACH NUMBER 5

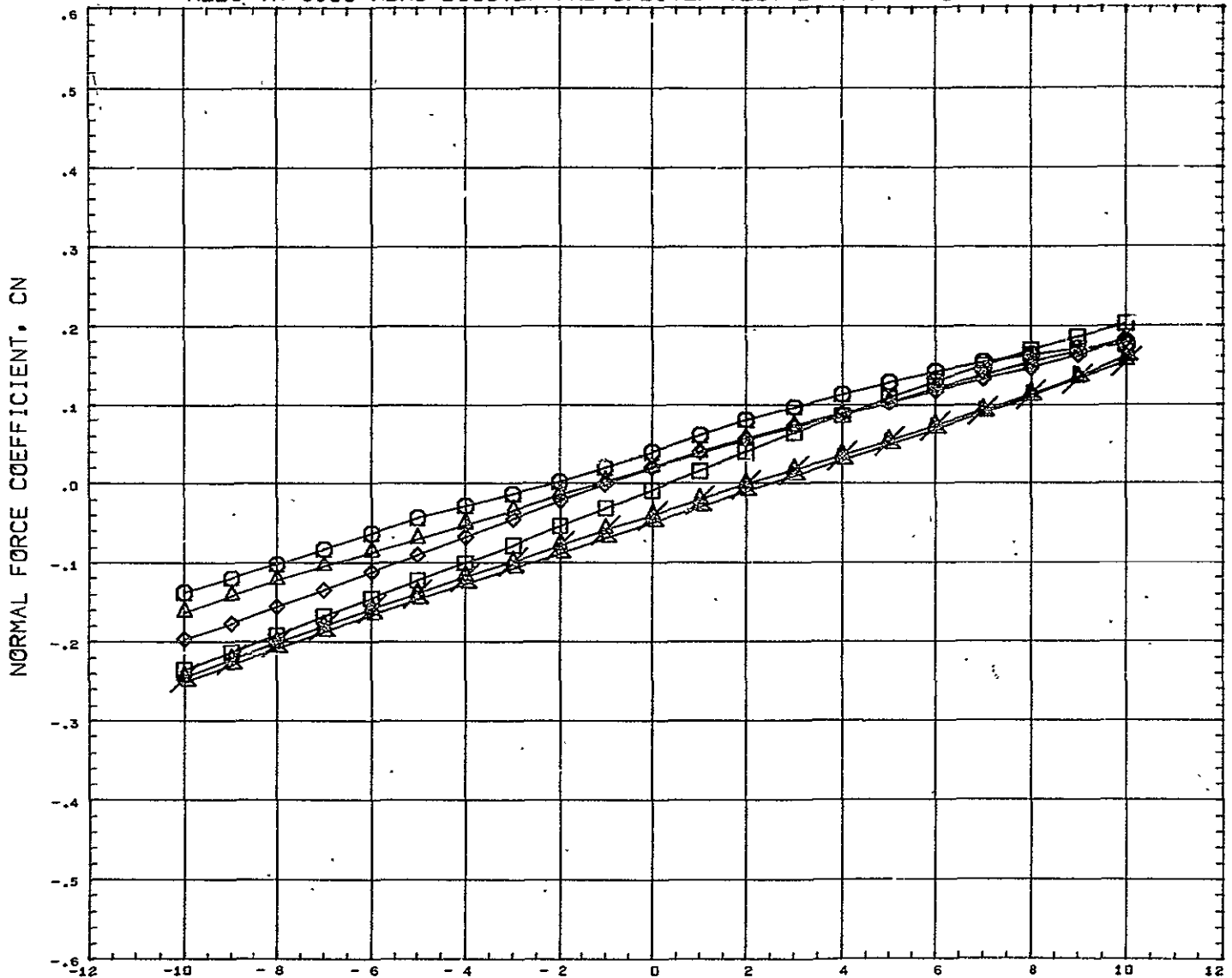

SYMBOL	DELTA Z	PARAMETRIC VALUES				REFERENCE INFORMATION		
○	0.120							
□	0.151							
◇	0.182	BSTFCW	0.000	ORBPOW	0.000	REFS	23.6890	SQ IN
△	0.228	DELTA X	0.104	ALPHA I	0.000	REFL	4.1930	IN
▽	0.352	MACH	5.010	ELVBST	20.000	REFB	6.5000	IN
×	10.000	ELVORB	-20.000	BETA	0.000	XMRP	4.9170	IN
						YMRP	0.0000	IN
						ZMRP	1.3900	IN
						SCALE	0.0055	

REFERENCE FILE

# AEDC VA 1163 MDAC BOOSTER AND ORBITER TEST DATA AT MACH NUMBER 5

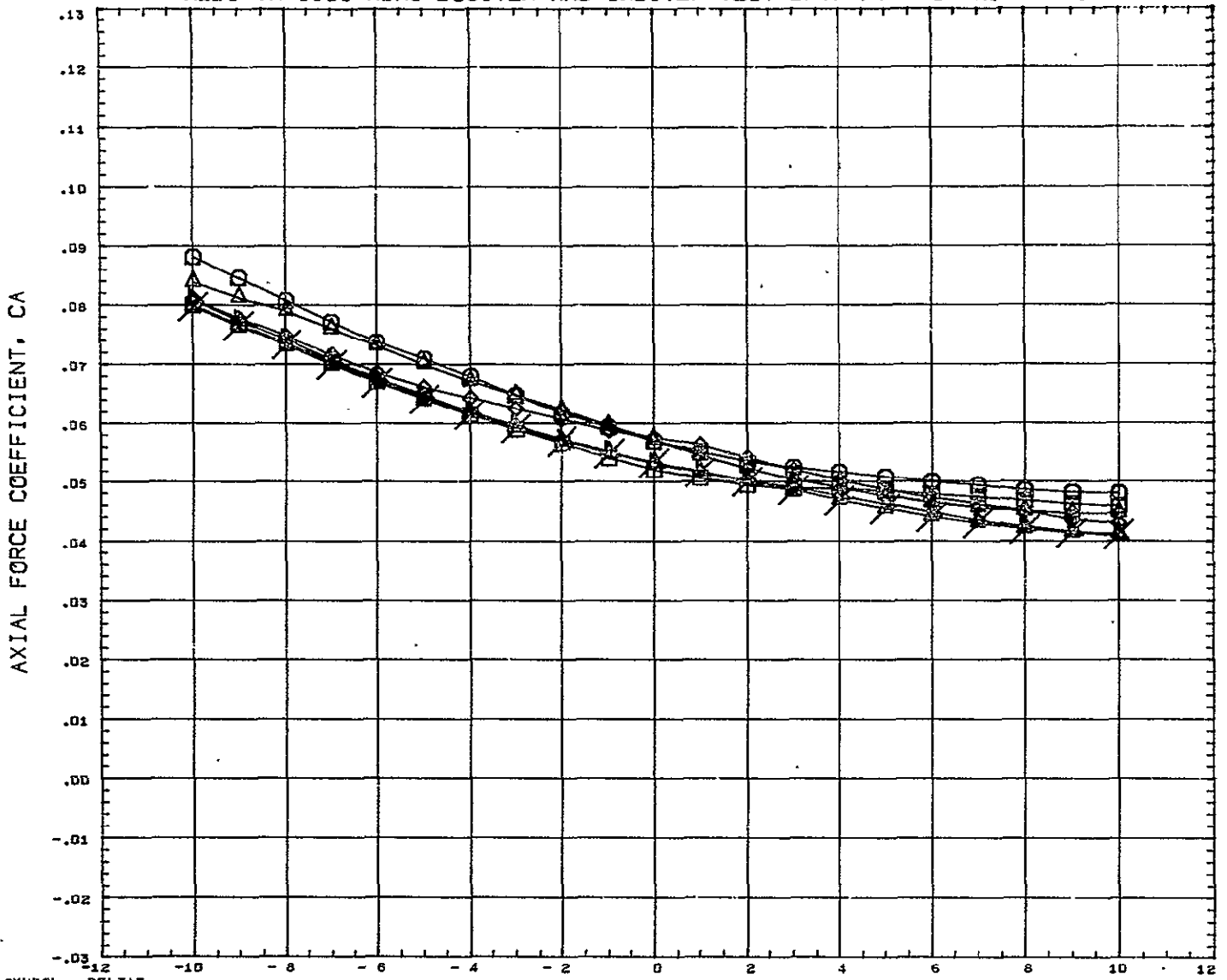

SYMBOL	DELTA Z	PARAMETRIC VALUES				REFERENCE INFORMATION		
○	0.120							
◇	0.151							
□	0.182	BSIFOW	0.000	ORBPOW	0.000	REFS	23.6890	50 IN
△	0.228	DELTA X	0.104	ALPHA I	0.000	REFL	4.1930	IN
◇	0.352	MACH	5.010	ELVBST	20.000	REFE	6.5000	IN
△	10.000	ELVORB	-20.000	BETA	0.000	XMRP	4.9170	IN
						YMRP	0.0000	IN
						ZMRP	1.3900	IN
						SCALE	0.0055	

REFERENCE FILE

# AEDC VA 1163 MDAC BOOSTER AND ORBITER TEST DATA AT MACH NUMBER 5

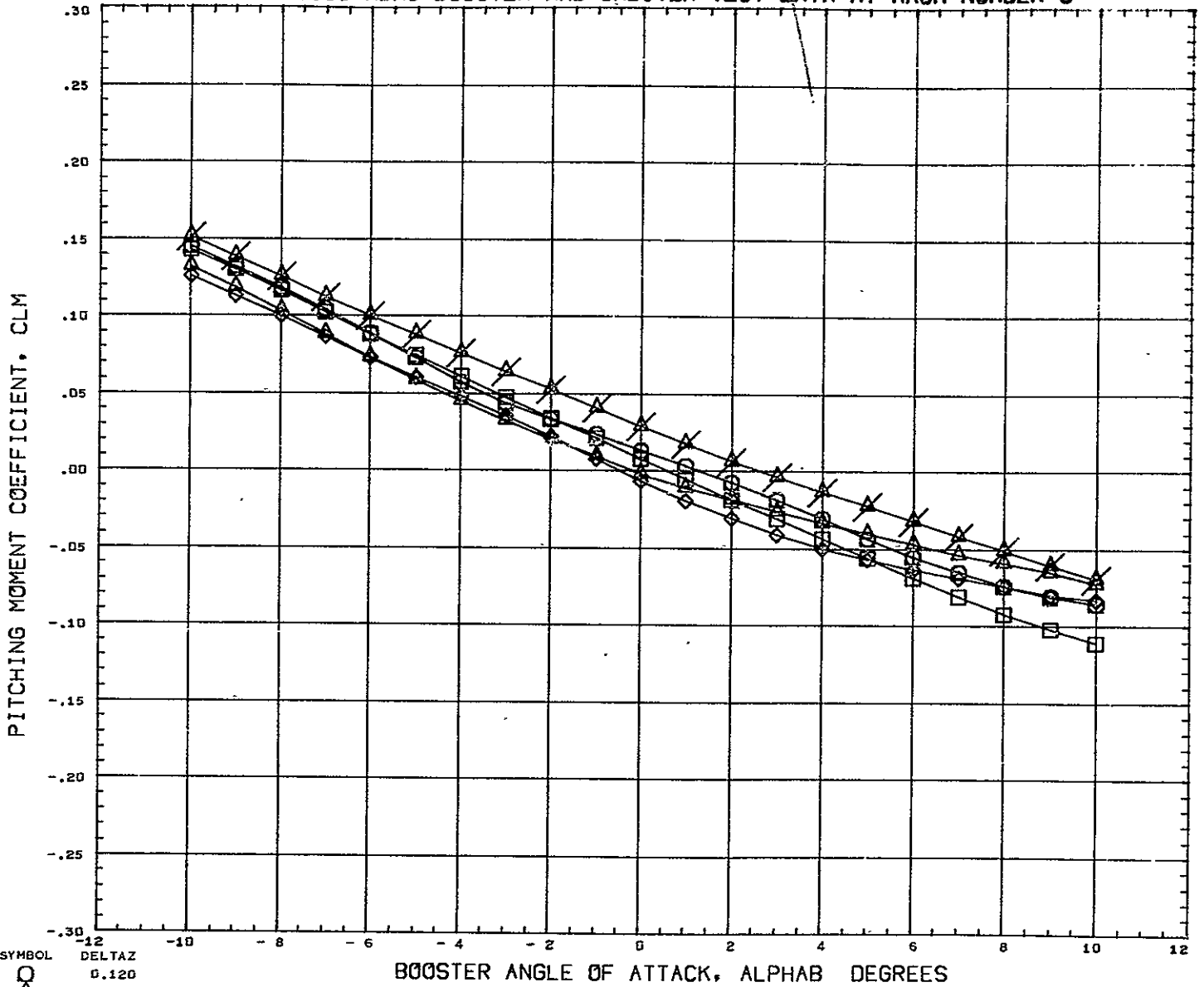

SYMBOL  
 ◇  
 ◻  
 ○  
 △  
 ×

DELTAZ  
 0.120  
 0.151  
 0.182  
 0.228  
 10.000

PARAMETRIC VALUES  
 BSTPOW 0.000 ORBPOW 0.000  
 DELTAX 0.166 ALPHAI 0.000  
 MACH 5.010 ELVBST 20.000  
 ELVORB - 20.000 BETA 0.000

REFERENCE INFORMATION  
 REFS 23.6890 SQ IN  
 REFL 4.1930 IN  
 REFD 6.5000 IN  
 XMRP 4.9175 IN  
 YMRP 0.0000 IN  
 ZMRP 1.3900 IN  
 SCALE 0.0055

REFERENCE FILE



# AEDC VA 1163 MDAC BOOSTER AND ORBITER TEST DATA AT MACH NUMBER 5

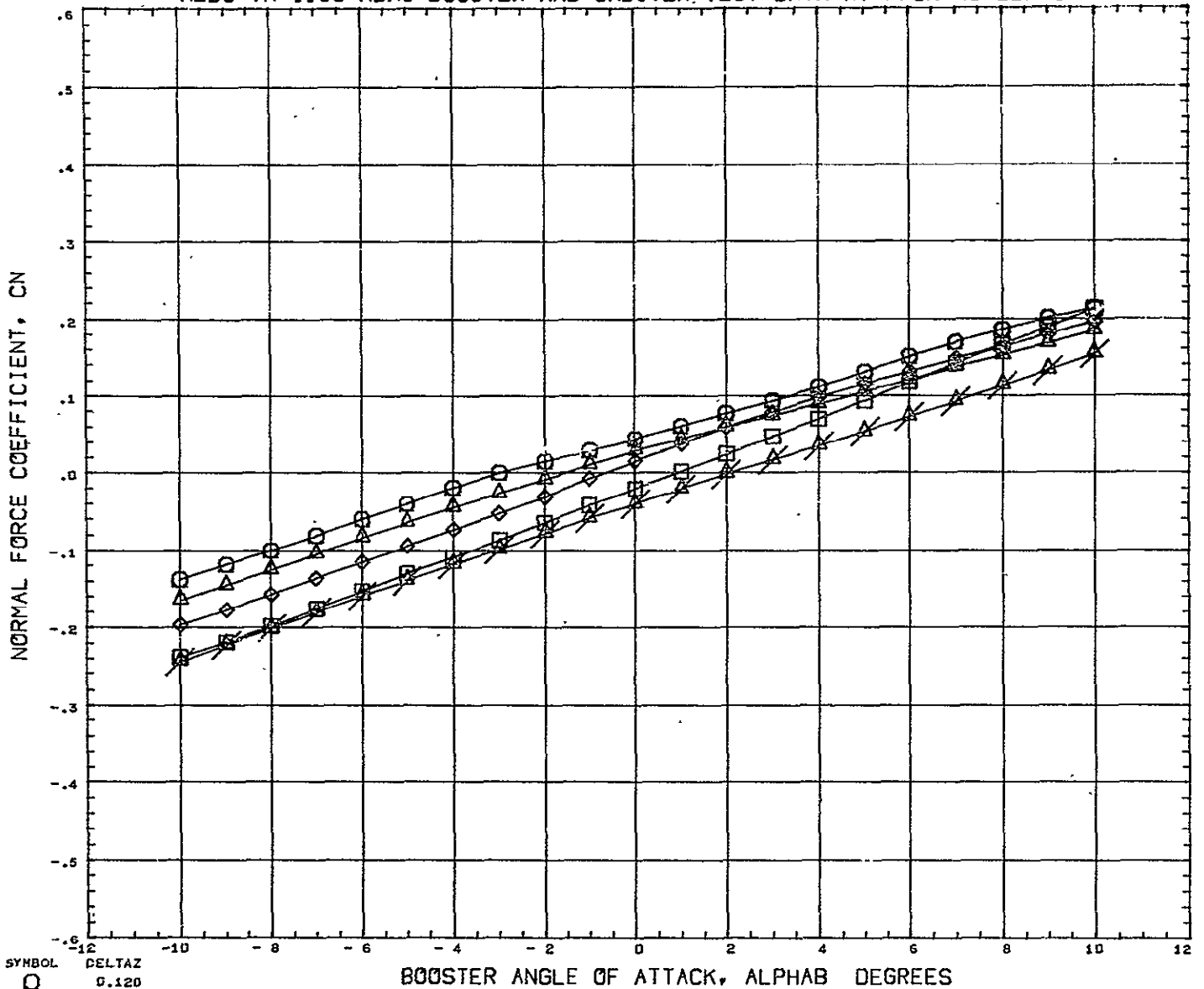

SYMBOL ○ □ ◇ △	DELTAX 0.120 0.151 0.182 0.228 10.000	<b>PARAMETRIC VALUES</b> BSTFOW    0.000    ORBPOW    0.000 DELTAX    0.166    ALPHA1    0.000 MACH      5.010    ELVBST    20.000 ELVORB    -20.000    BETA      0.000	<b>REFERENCE INFORMATION</b> REFS      23.6890    SQ IN REFL      -4.1930    IN REFB      6.5000    IN XMRF      4.9170    IN YMRF      0.0000    IN ZMRF      1.3900    IN SCALE     0.0055
REFERENCE FILE			

# AEDC VA 1163 MDAC BOOSTER AND ORBITER TEST DATA AT MACH NUMBER 5

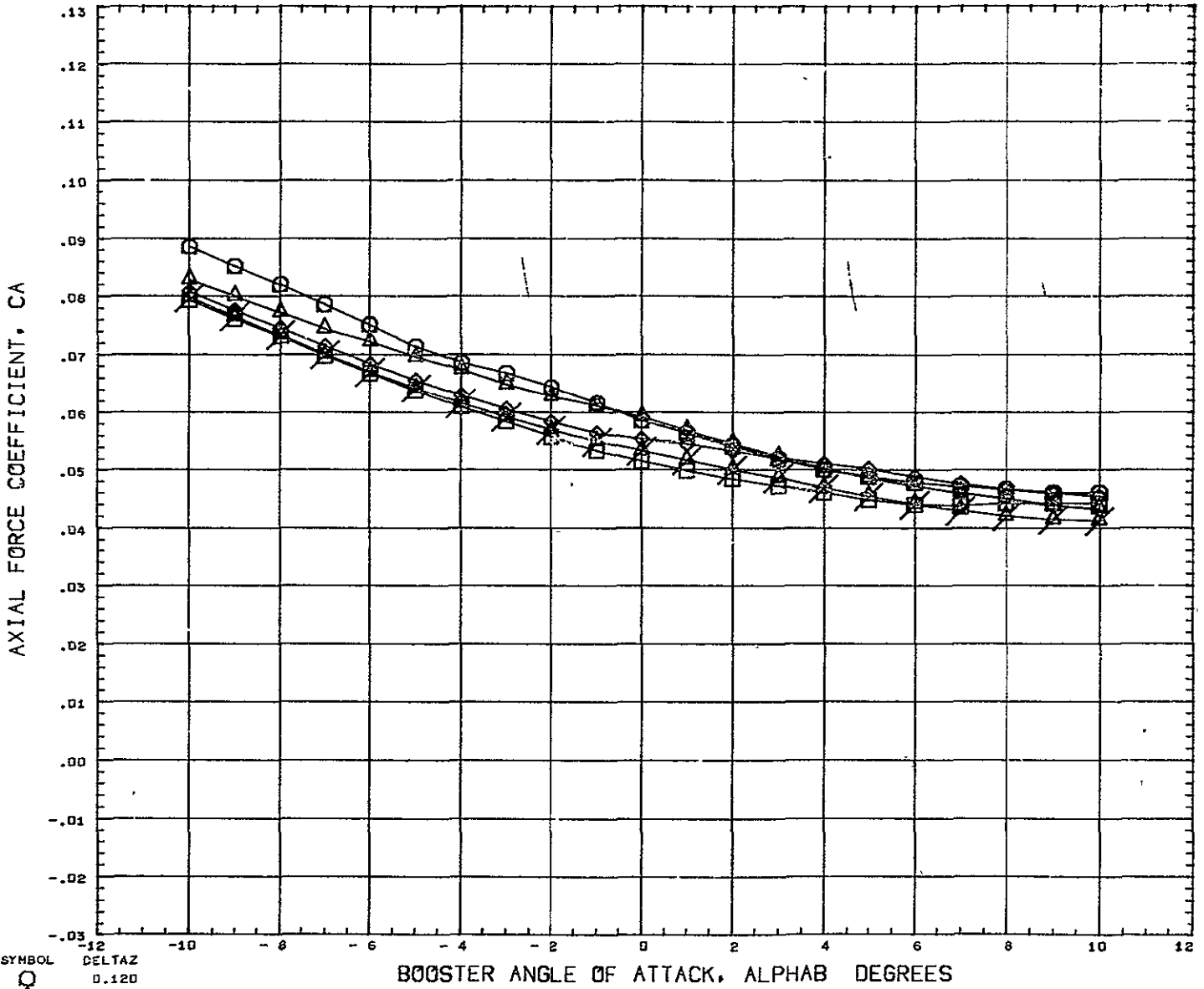

SYMBOL 	DELTAX 0.120 0.151 0.182 0.228 10.000	PARAMETRIC VALUES BSTFOW 0.000 ORBFOV 0.000 DELTAX 0.166 ALPHAI 0.000 MACH 5.010 ELVBST 20.000 ELVORB -20.000 BETA 5.000	REFERENCE INFORMATION REFS 23.6890 SQ IN REFL 4.1930 IN REFB 6.5030 IN XMRP 4.9170 IN YMRP 0.0000 IN ZMRP 1.3900 IN SCALE 0.0055
------------	--	--	---

REFERENCE FILE

# AEDC VA 1163 MDAC BOOSTER AND ORBITER TEST DATA AT MACH NUMBER 5

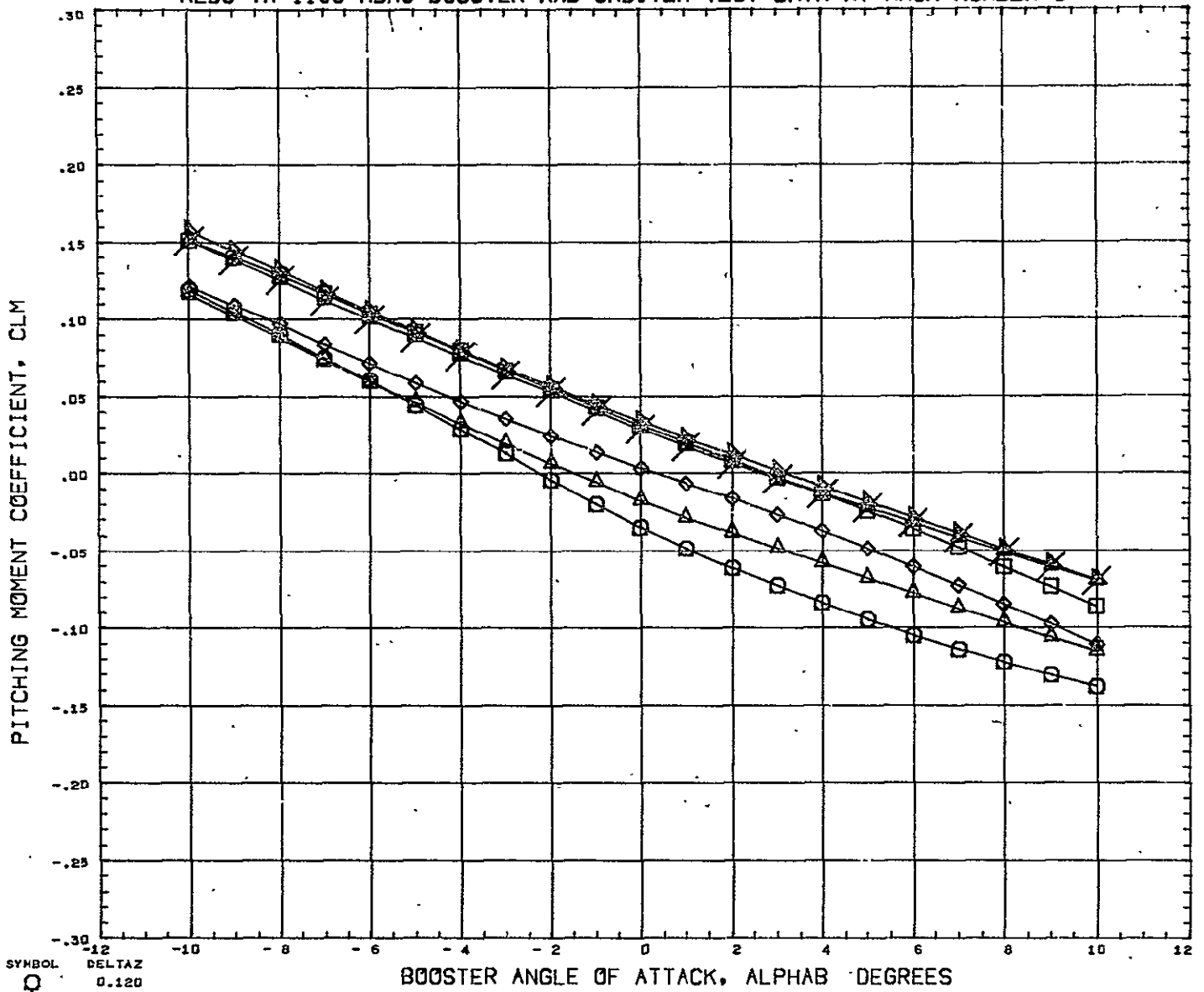

SYMBOL 	DELTAX 0.120 0.151 0.182 0.226 0.352 10.000	PARAMETRIC VALUES BSTPOW    0.000    ORBPOW    0.000 DELTAX    0.352    ALPHAI    0.000 MACH       5.010    ELVBST    20 000 ELVORB    -20.000    BETA       0.000	REFERENCE INFORMATION REFS       23.6890    SQ IN REFL       4.1930    IN REFB       6.5000    IN XMRF       4.9170    IN YMRF       0.0000    IN ZMRF       1.3900    IN SCALE      0.0055
REFERENCE FILE			

# AEDC VA 1163 MDAC BOOSTER AND ORBITER TEST DATA AT MACH NUMBER 5

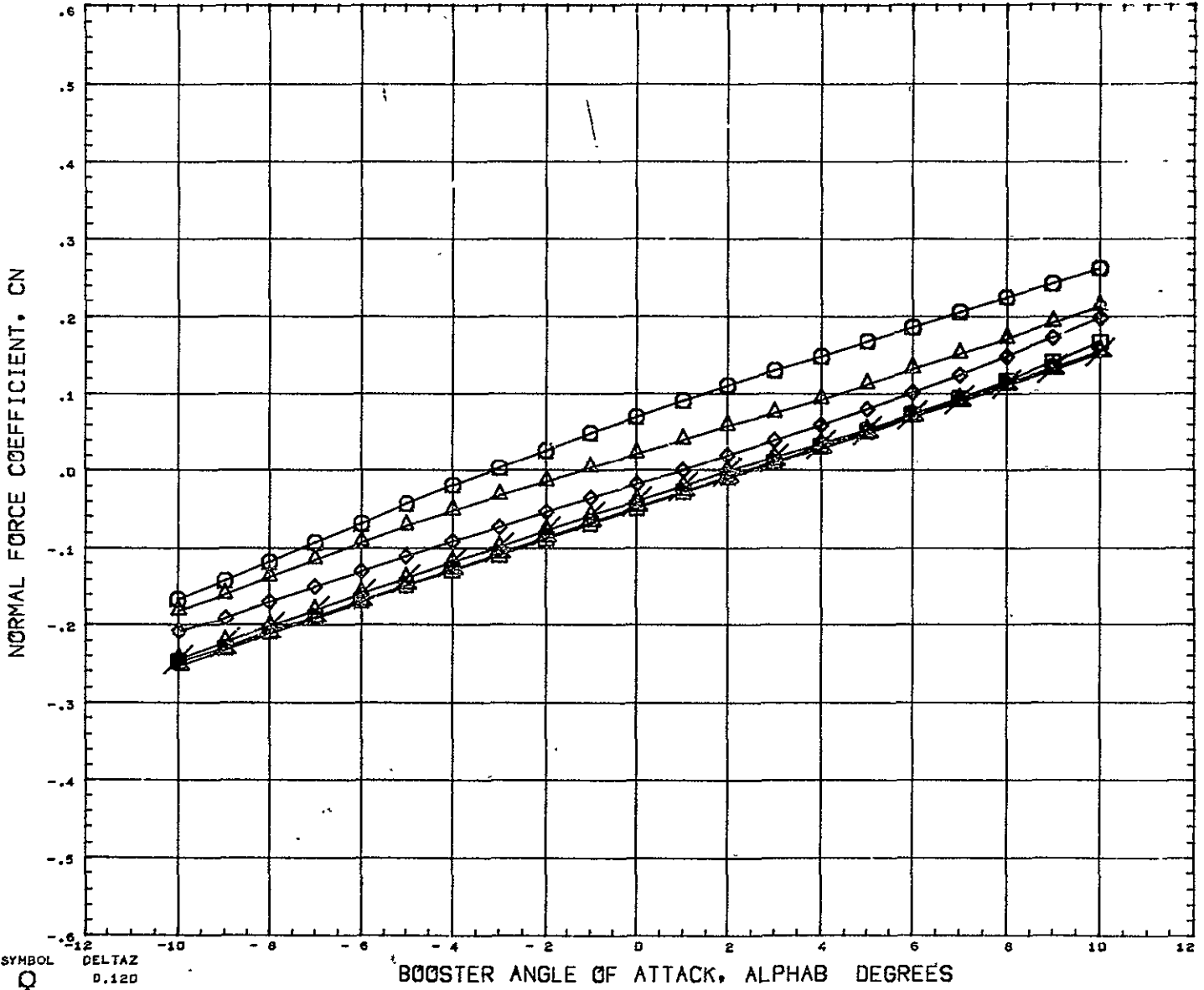

SYMBOL ○ ◇ △ □ ×	DELTAZ 0.120 0.151 0.182 0.228 0.352 10.000	PARAMETRIC VALUES BSIFOW 0.000 ORBFGW 0.000 DELTAX 0.352 ALPHA1 0.000 MACH 5.010 ELVBST 20.000 ELVORB -20.000 BETA 0.000	REFERENCE INFORMATION REFS 23.6890 SQ IN REFL 4.1930 IN REFE 6.5080 IN XMRP 4.9170 IN YMRP 0.0000 IN ZMRP 1.3900 IN SCALE 0.0055
REFERENCE FILE			

# AEDC VA 1163 MDAC BOOSTER AND ORBITER TEST DATA AT MACH NUMBER 5

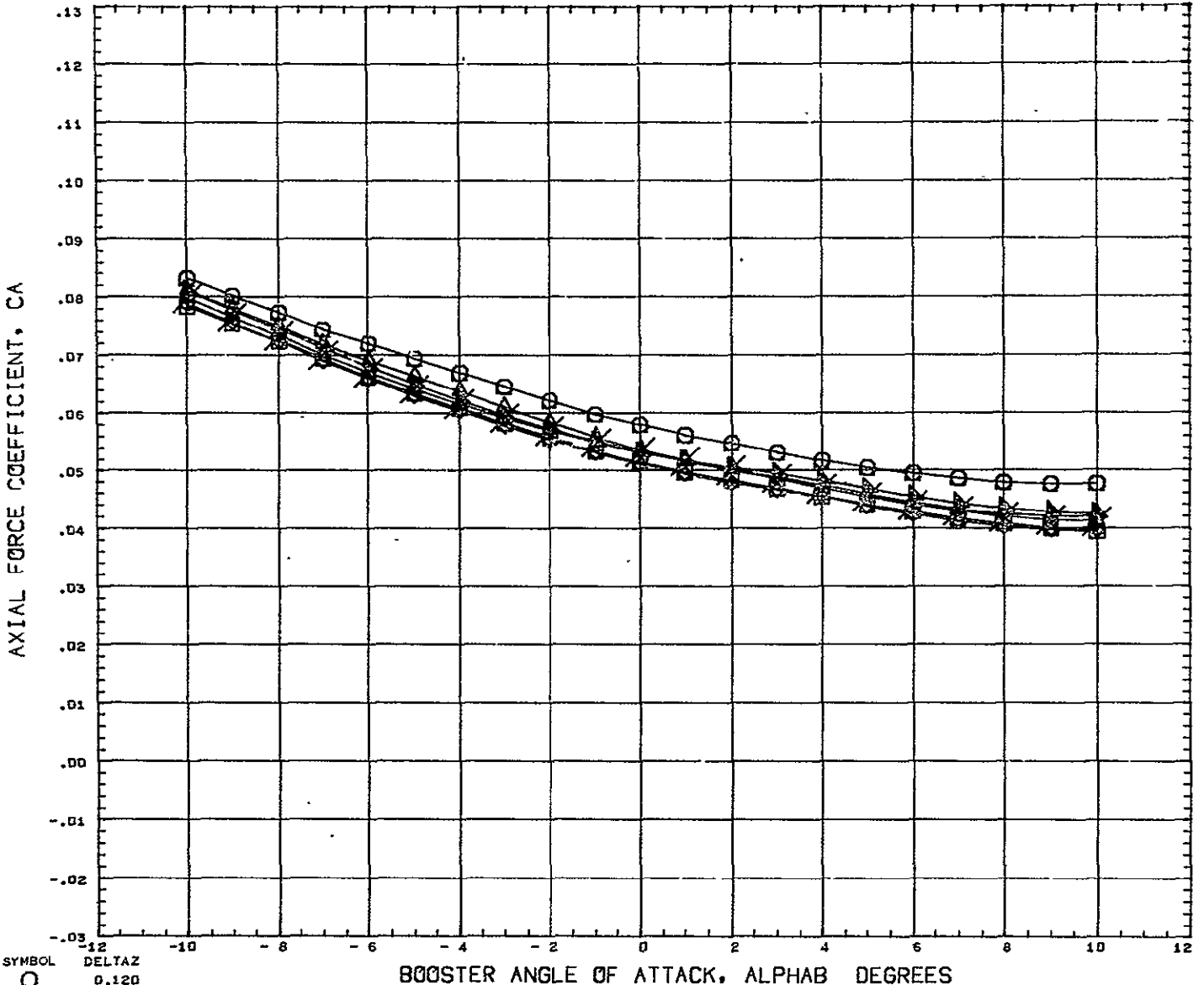

SYMBOL ○ ◇ □ △ ▽	DELTAZ 0.120 0.151 0.182 0.228 0.352 10.000	PARAMETRIC VALUES BSIFOW 0.000 ORBPOW 0.000 DELTAX 0.352 ALPHAI 0.000 MACH 5.010 ELVBST 20.000 ELVORB -20.000 BETA 0.000	REFERENCE INFORMATION REFS 23.6890 SQ IN REFL 4.1930 IN REFB 6.5000 IN XHRP 4.917C IN YHRP 0.0000 IN ZHRP 1.3900 IN SCALE 0.0055
---------------------------------	---	--	---

REFERENCE FILE

# AEDC VA 1163 MDAC BOOSTER AND ORBITER TEST DATA AT MACH NUMBER 5

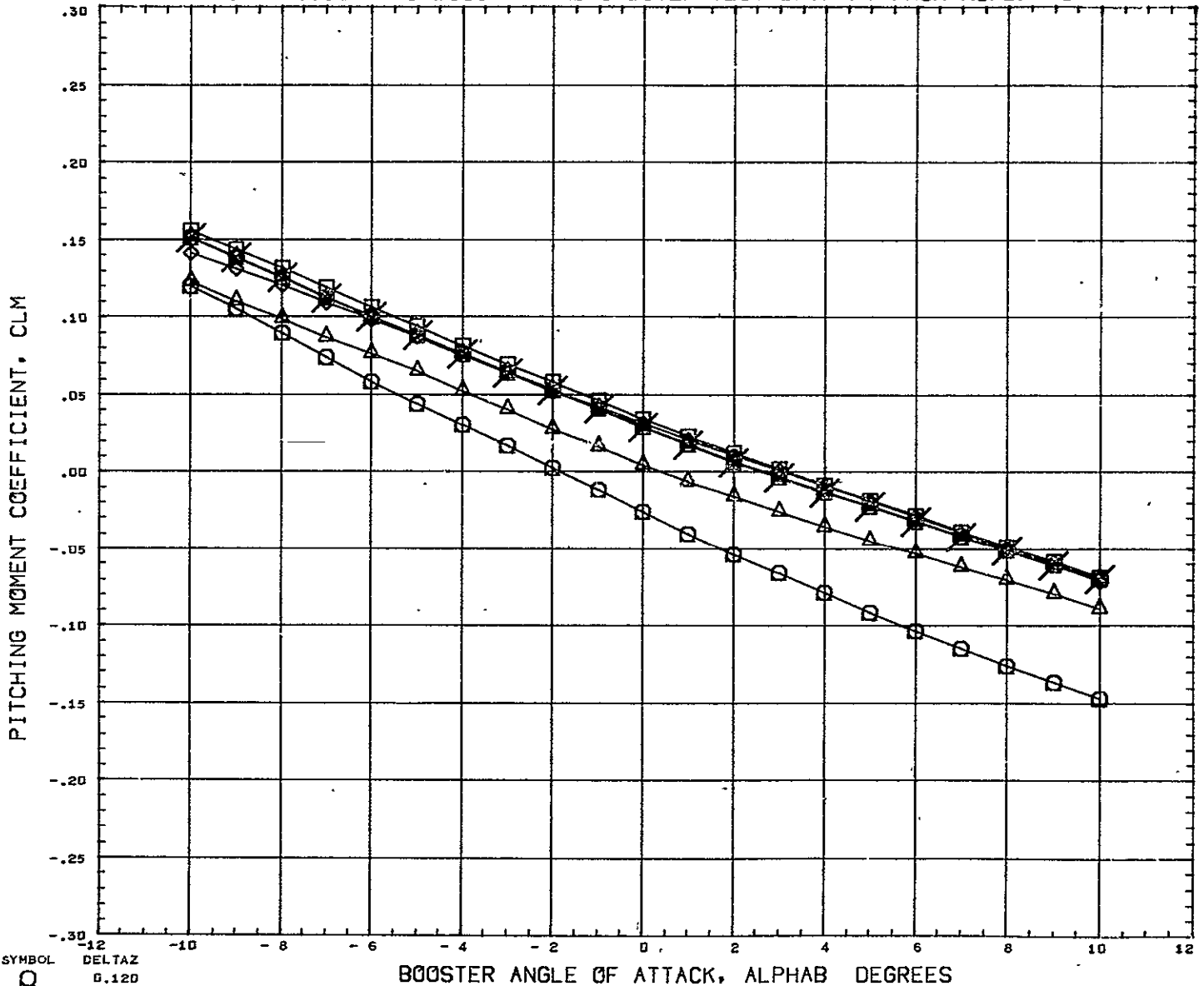

SYMBOL     	DELTAZ 0.120 0.151 0.182 0.228 0.908 10.000	PARAMETRIC VALUES BSTPOW 0.000 ORBPOW 0.000 DELTAX 0.522 ALPHAI 0.000 MACH 5.010 ELVBST 20.000 ELVORB - 20.000 BETA 0.000	REFERENCE INFORMATION REFS 23.6890 SQ IN REFL 4.1930 IN REF3 6.5000 IN XMRP 4.9170 IN YMRP 0.0000 IN ZMRP 1.3900 IN SCALE 0.0055
----------------------------	---	---	---

REFERENCE FILE

# AEDC VA 1163 MDAC BOOSTER AND ORBITER TEST DATA AT MACH NUMBER 5

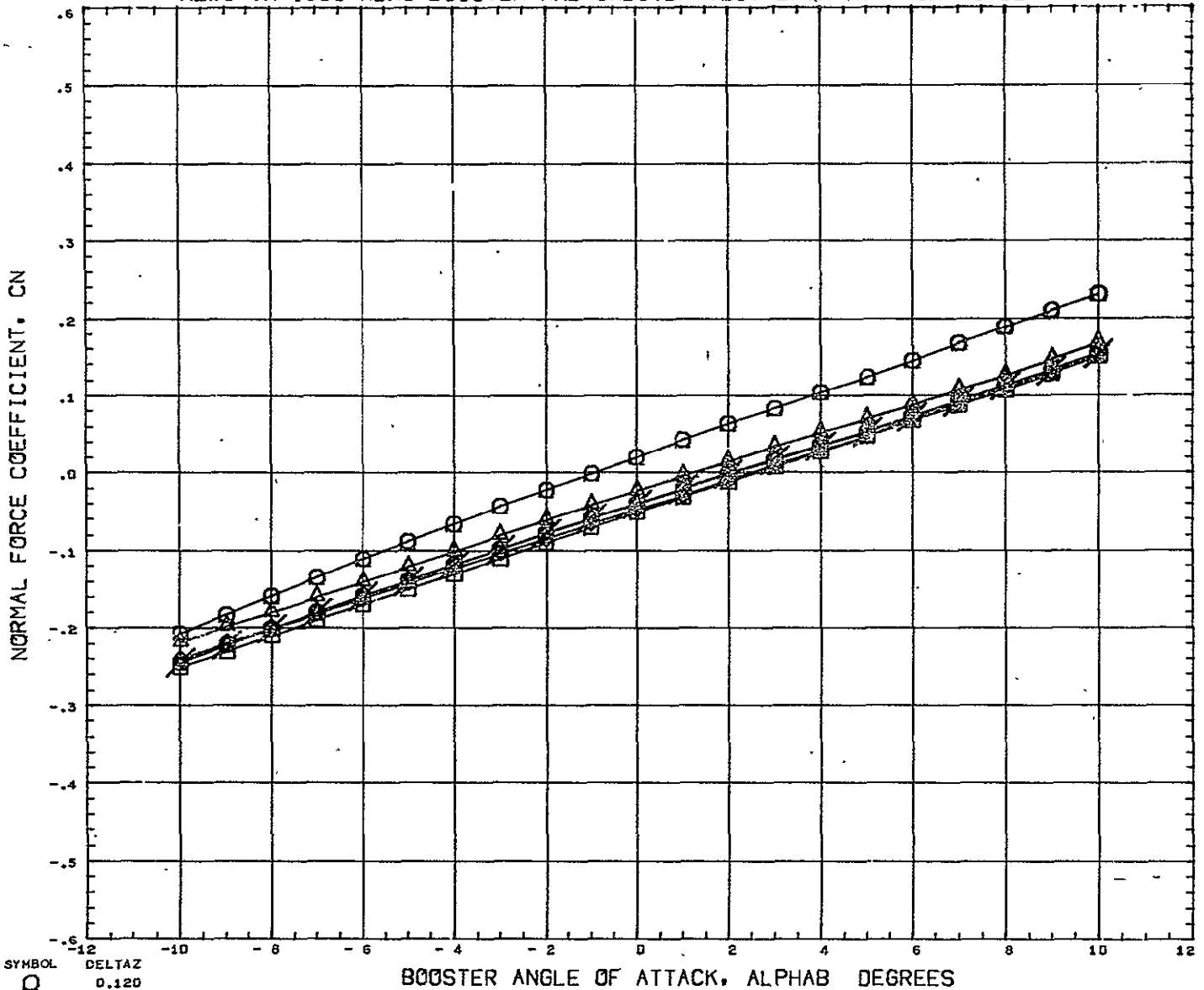

SYMBOL ○ △ □ ◇ <del>○</del> <del>△</del> <del>□</del> <del>◇</del>	DELTA Z 0.120 0.151 0.182 0.228 0.908 10.000	PARAMETRIC VALUES BSTPOW 0.000 ORBPOW 0.000 DELTAX 0.522 ALPHAI 0.000 MACH 5.010 ELVBST 20.000 ELVORB -20.000 BETA 0.000	REFERENCE INFORMATION REFS 23.6890 SQ IN REFL 4.1930 IN REFB 6.5000 IN XMRP 4.9170 IN YMRP 0.0000 IN ZMRP 1.3900 IN SCALE 0.0055
REFERENCE FILE			

# AEDC VA 1163 MDAC BOOSTER AND ORBITER TEST DATA AT MACH NUMBER 5

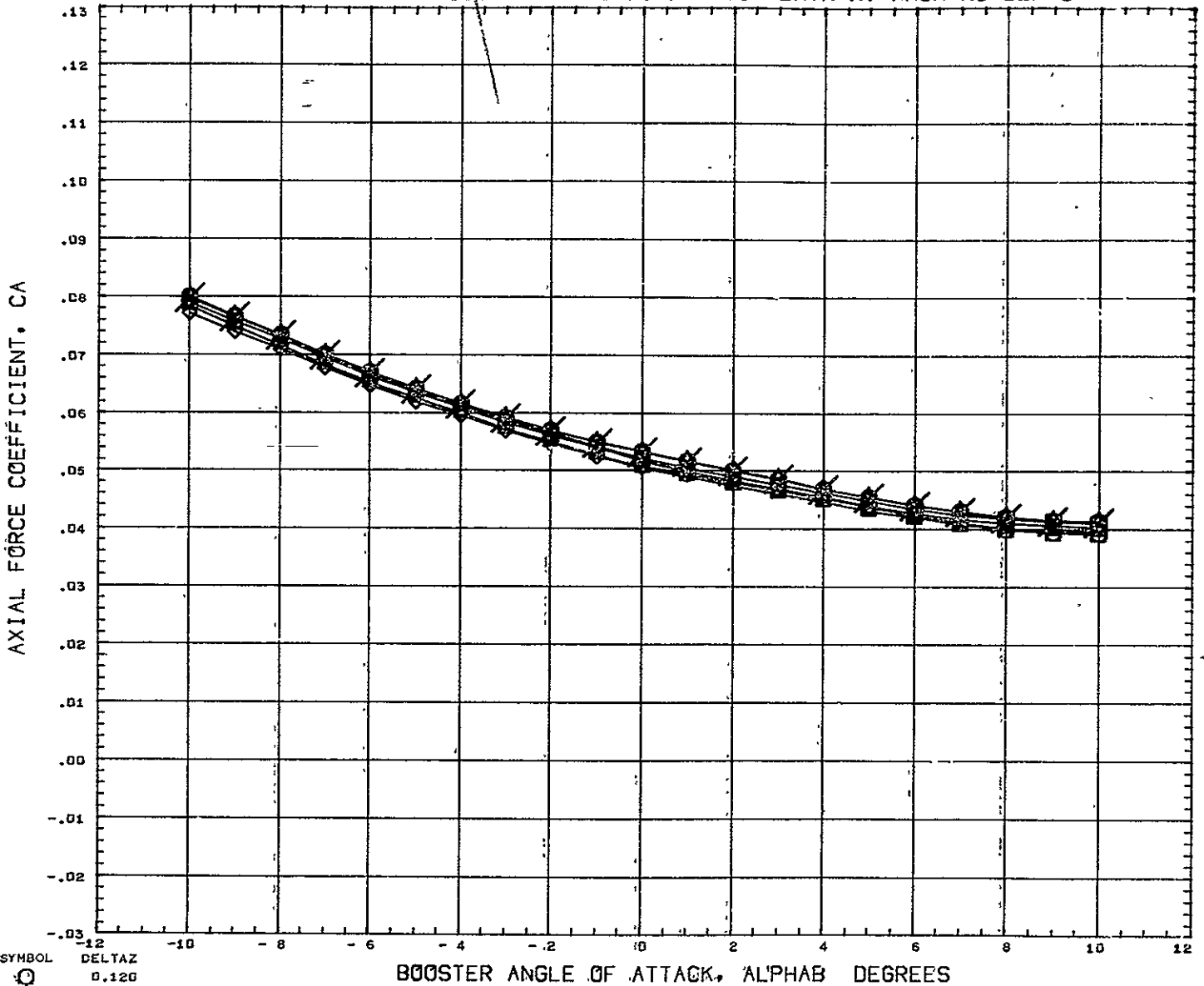

SYMBOL $\Delta$ $\square$ $\diamond$ $\circ$ $\times$	DELTAX 0.120 0.151 0.182 0.228 0.908 10.000	<b>PARAMETRIC VALUES</b> BSTPOW    0.000    ORBPOW    0.000 DELTAX    0.522    ALPHAI    0.000 MACH      5.010    ELVBST    20.000 ELVORB    -20.000    BETA      0.000	<b>REFERENCE INFORMATION</b> REFS      23.6890    SQ IN REFL      4.1930    IN REFB      6.5000    IN XMRP      4.9170    IN YMRP      0.0000    IN ZMRP      1.3900    IN SCALE     0.0055
REFERENCE FILE			



# AEDC VA 1163 MDAC BOOSTER AND ORBITER TEST DATA AT MACH NUMBER 5

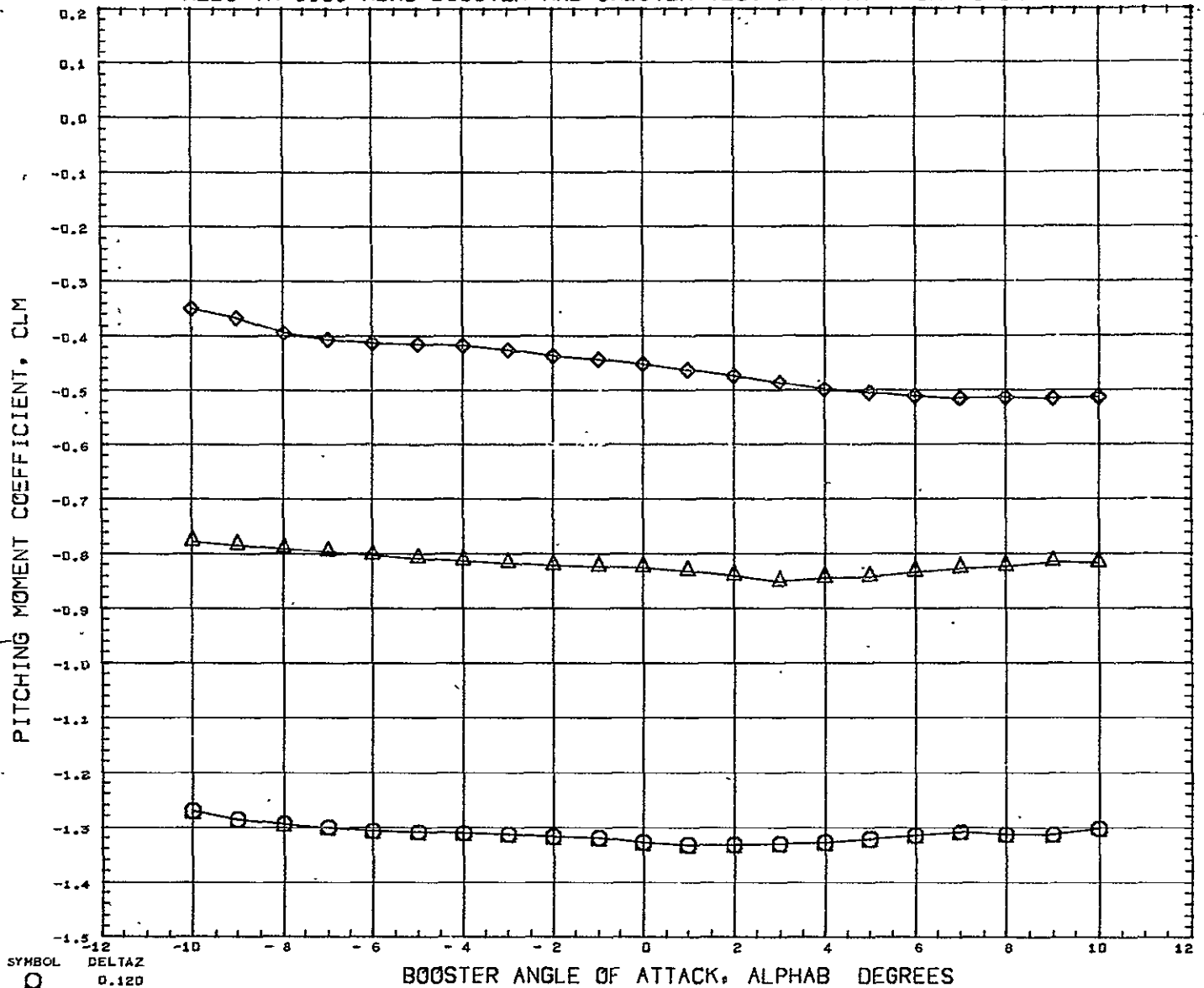

SYMBOL ○ △ ◇	DELTAZ 0.120 0.151 0.182	<b>PARAMETRIC VALUES</b> BSTFOW 100.000    ORBFOW 100.000 DELTAX - 0.390    ALPHAI 0.000 MACH 5.010        ELVBST 20.000 ELVORB - 20.000    BETA 0.000	<b>REFERENCE INFORMATION</b> REFS 23.6890    SQ IN REFL 4.1930    IN REFB 6.5000    IN XHRF 4.9170    IN YHRF 0.0000    IN ZHRF 1.3900    IN SCALE 0.0055
REFERENCE FILE			

# AEDC VA 1163 MDAC BOOSTER AND ORBITER TEST DATA AT MACH NUMBER 5

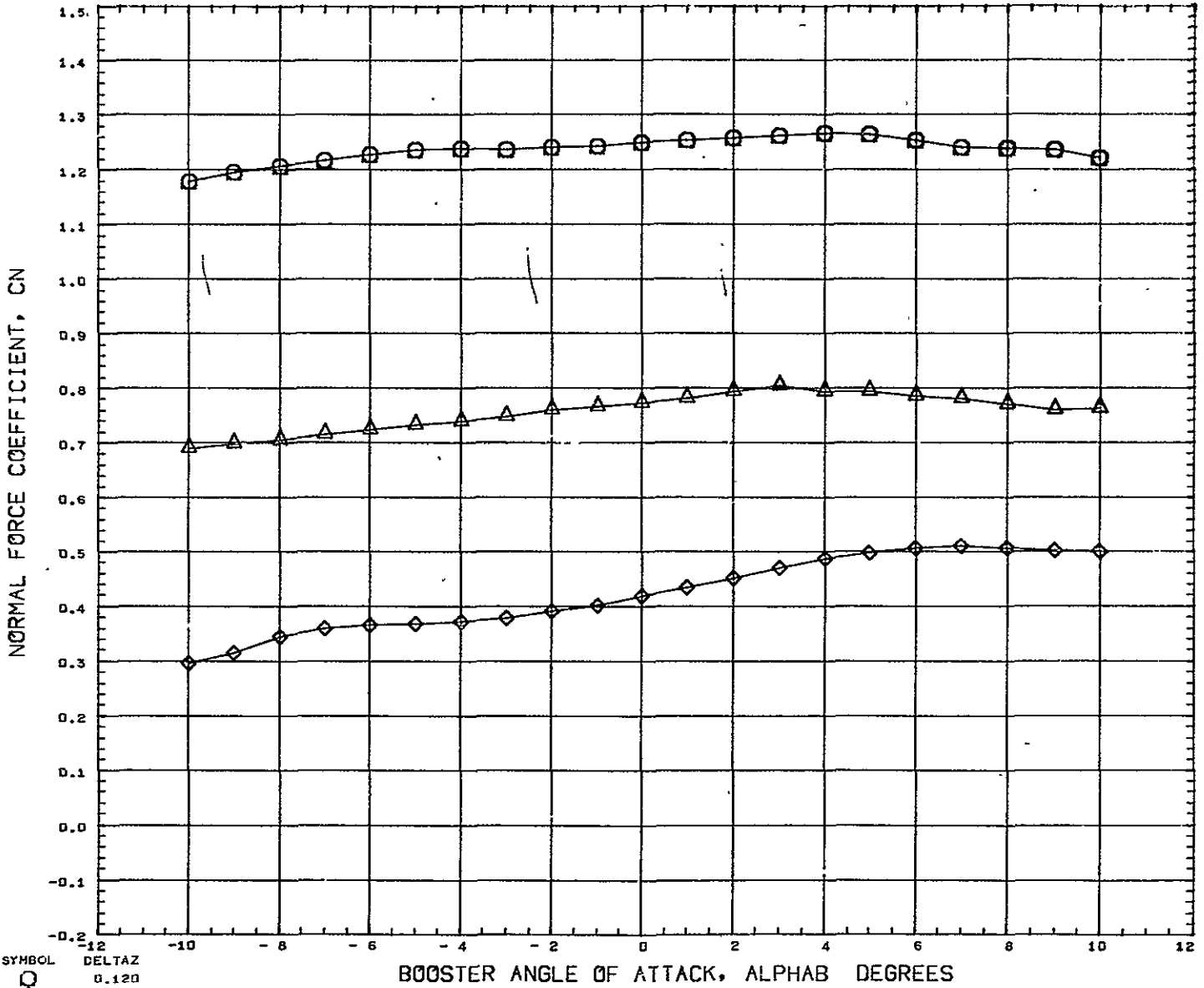

SYMBOL ○ △ ◇	DELTAX 0.120 0.151 0.182	PARAMETRIC VALUES BSTFOW 100.000    ORBFOW 100.000 DELTAX - 0.390    ALPHAI 0.000 MACH 5.010        ELVBST 20.000 ELVORB - 20.000    BETA 0.000	REFERENCE INFORMATION REFS 23.6890        SQ IN REFL 4.1930        IN REFB 6.5000        IN XMRP 4.91.0        IN YMRP 0.0000        IN ZMRP 1.3900        IN SCALE 0.0055
-----------------------	-----------------------------------	---	---

REFERENCE FILE

# AEDC VA 1163 MDAC BOOSTER AND ORBITER TEST DATA AT MACH NUMBER 5

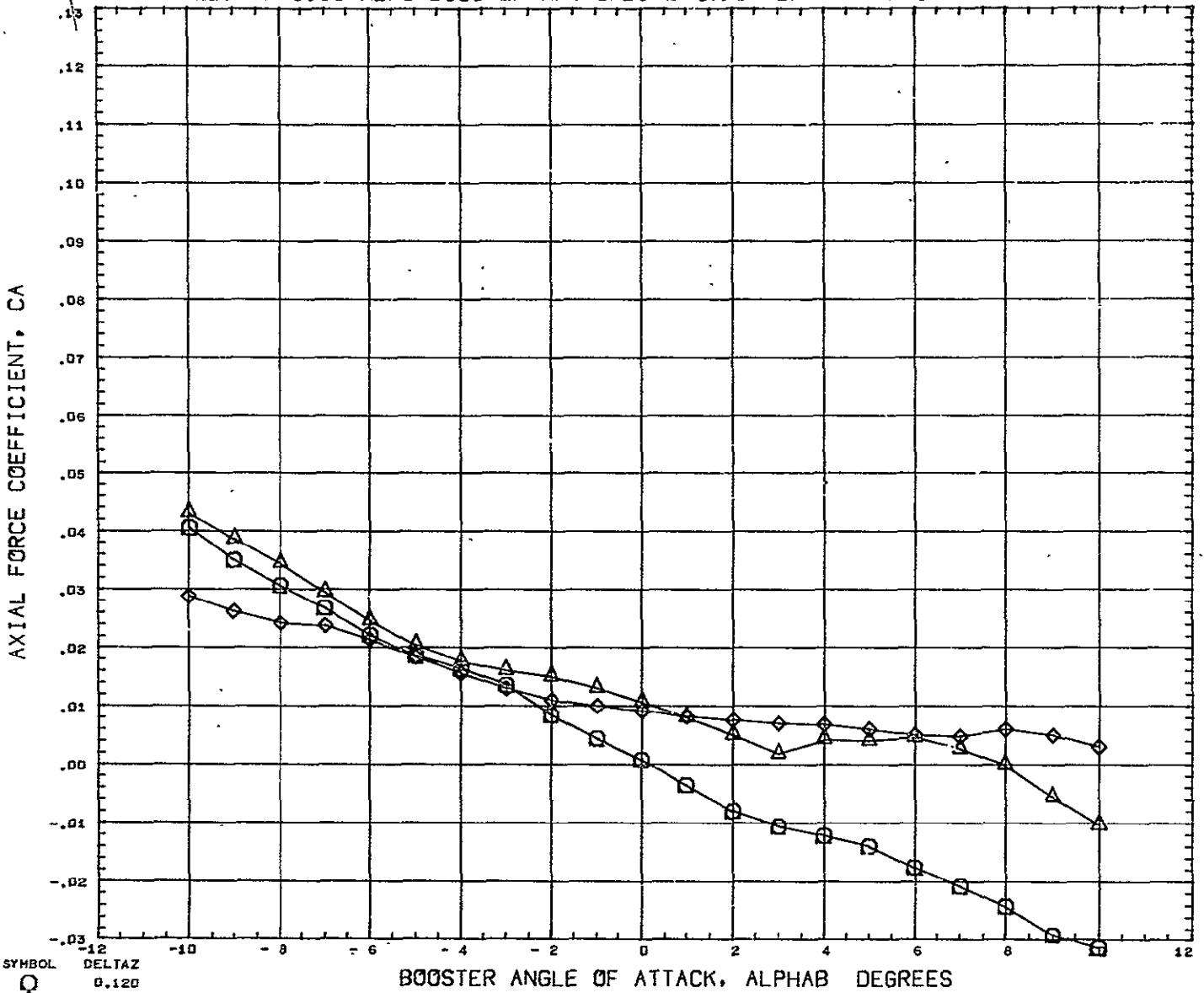

SYMBOL    DELTA Z  
 ◻        0.120  
 ◻        0.151  
 ◻        0.182

PARAMETRIC VALUES

BSTPOW	100.000	ORBPOW	100.000
DELTA X	- 0.390	ALPHA I	0.000
MACH	5.010	ELVBST	20.300
ELVORB	- 20.000	BETA	3.000

REFERENCE INFORMATION

REFS	23.6890	SQ IN
REFL	4.1930	IN
REFB	6.5000	IN
XMRP	4.9170	IN
YMRP	0.0000	IN
ZMRP	1.3900	IN
SCALE	0.0055	

REFERENCE FILE

# AEDC VA 1163 MDAC BOOSTER AND ORBITER TEST DATA AT MACH NUMBER 5

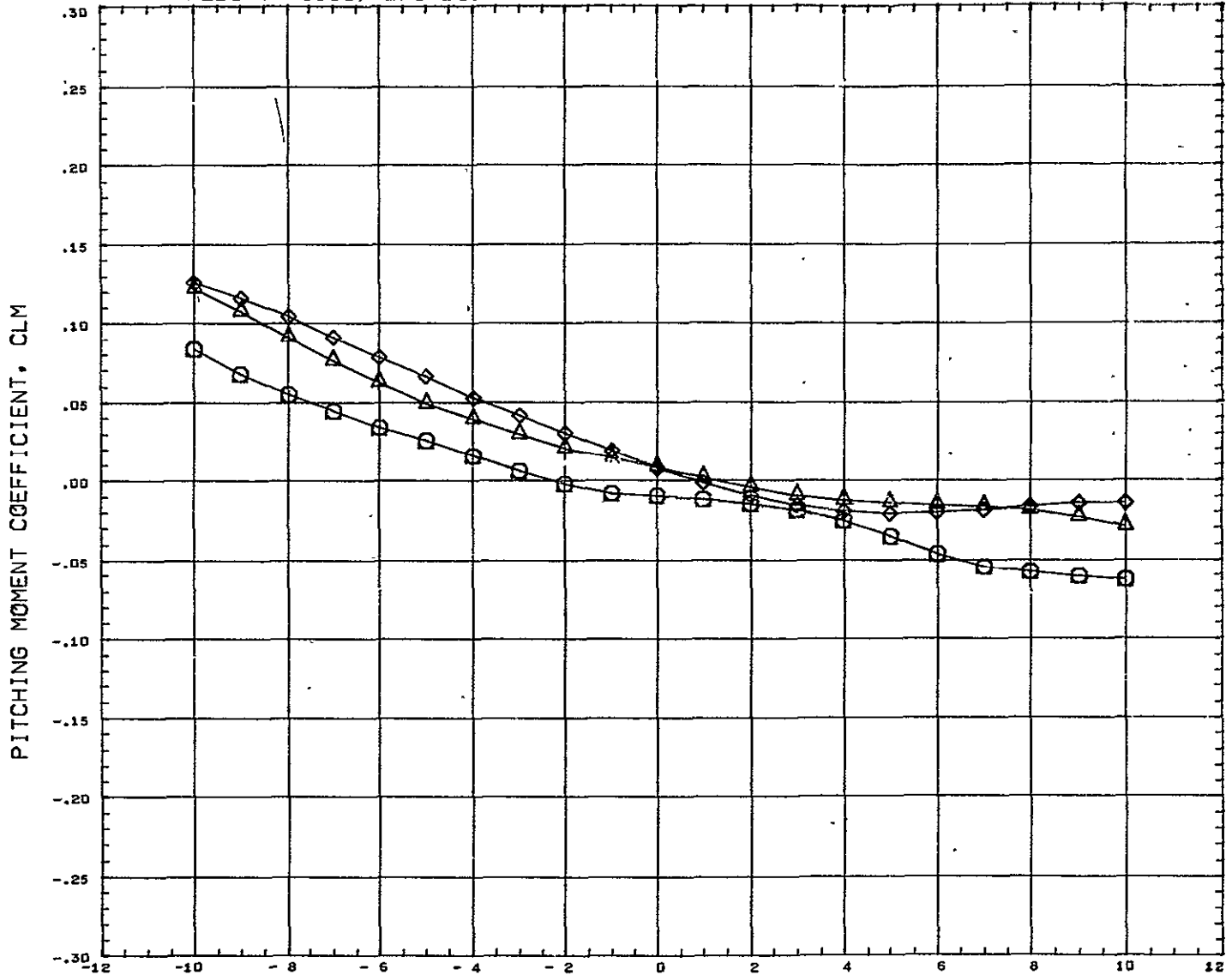

SYMBOL ◊ ◻ ◻	DELTA Z 0.120 0.151 0.182	<b>PARAMETRIC VALUES</b> BSTFOW 100.000 ORBPOW 100.000 DELTAX - 0.143 ALFHAI 0.000 MACH 5.010 ELVBST 20.000 ELVORB - 20.000 BETA 0.000	<b>REFERENCE INFORMATION</b> REFS 23.6890 SQ IN REFL 4.1930 IN REFB 6.5000 IN XMRP 4.9170 IN YMRP 0.0000 IN ZMRP 1.3900 IN SCALE 0.0055
DATA HIST. CODE *G			

# AEDC VA 1163 MDAC BOOSTER AND ORBITER TEST DATA AT MACH NUMBER 5

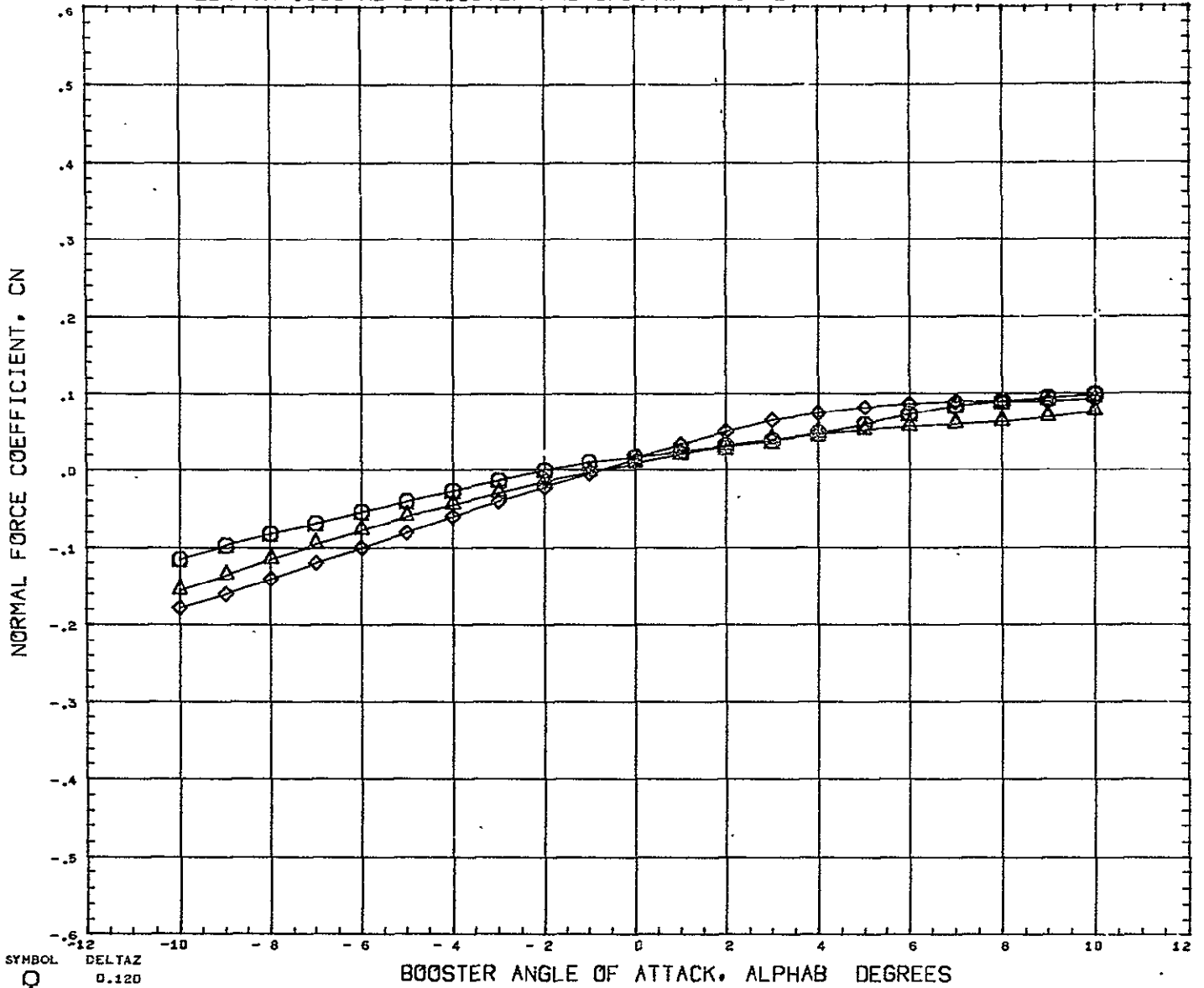

SYMBOL  
 ○  
 △  
 ◇

DELTA Z  
 0.120  
 0.151  
 0.192

PARAMETRIC VALUES  
 BSTPOW 100.000 ORBPOW 100.000  
 DELTAX - 0.143 ALPHA1 0.000  
 MACH 5.010 ELVBST 20.000  
 ELVORB - 20.000 BETA 0.000

REFERENCE INFORMATION  
 REFS 23.6890 SQ IN  
 REFL 4.1930 IN  
 REFB 6.5000 IN  
 XMRP 4.9170 IN  
 YMRP 0.0060 IN  
 ZMRP 1.3900 IN  
 SCALE 0.0055

DATA HIST. CODE \*G

# AEDC VA 1163 MDAC BOOSTER AND ORBITER TEST DATA AT MACH NUMBER 5

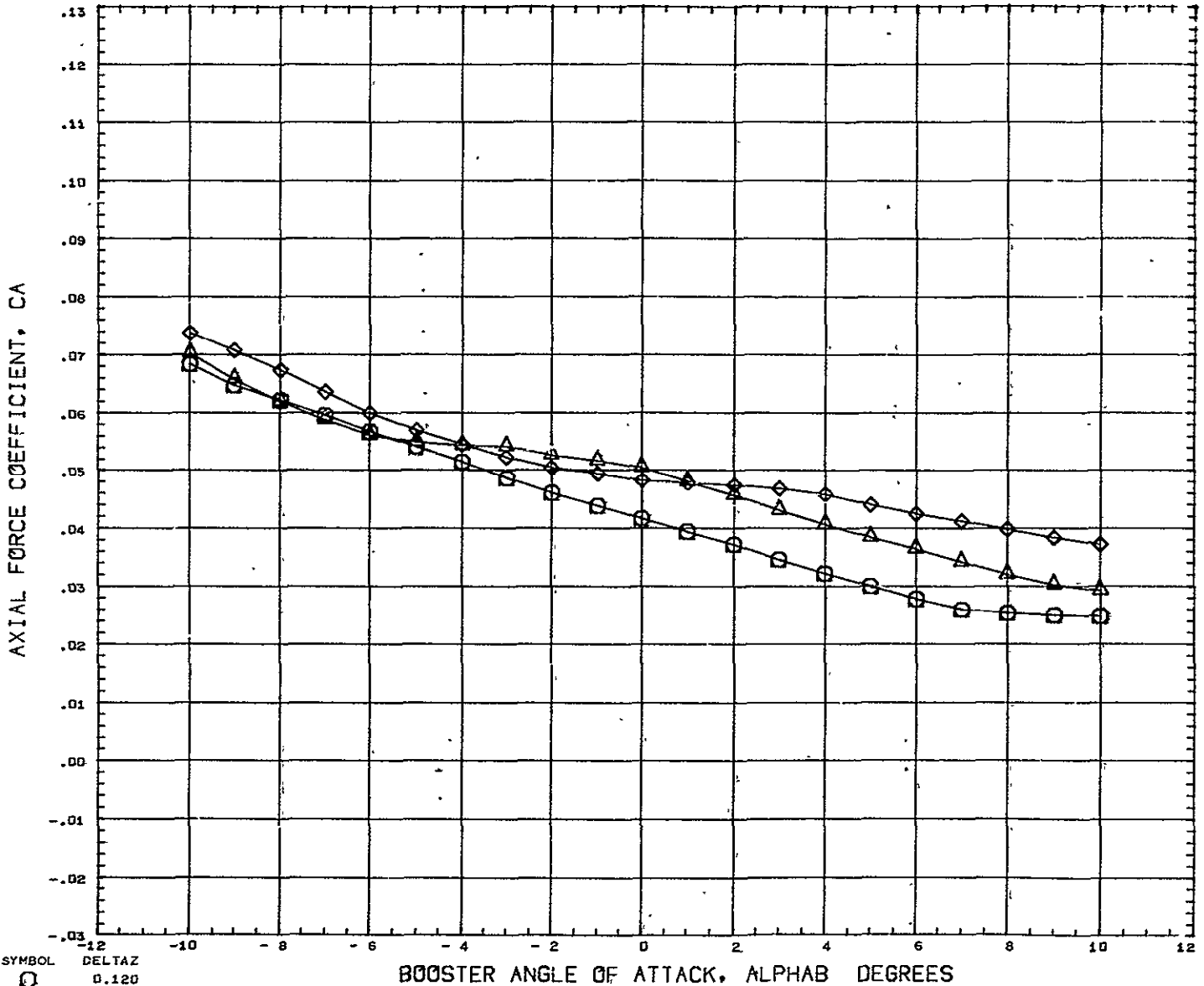

SYMBOL □ △ ◇	DELTA Z 0.120 0.151 0.182	PARAMETRIC VALUES BSTPOW 100.000 ORBPOW 100.000 DELTAX - 0.143 ALPHAI 0.000 MACH 5.010 ELVBST 20.000 ELVORB - 20.000 BETA 0.000	REFERENCE INFORMATION REFS 23.6890 SQ IN REFL 4.1930 IN REFB 6.5000 IN XMRP 4.9170 IN YMRP 0.0000 IN ZMRP 1.3900 IN SCALE 0.0055
-----------------------	------------------------------------	---	---

# AEDC VA 1163 MDAC BOOSTER AND ORBITER TEST DATA AT MACH NUMBER 5

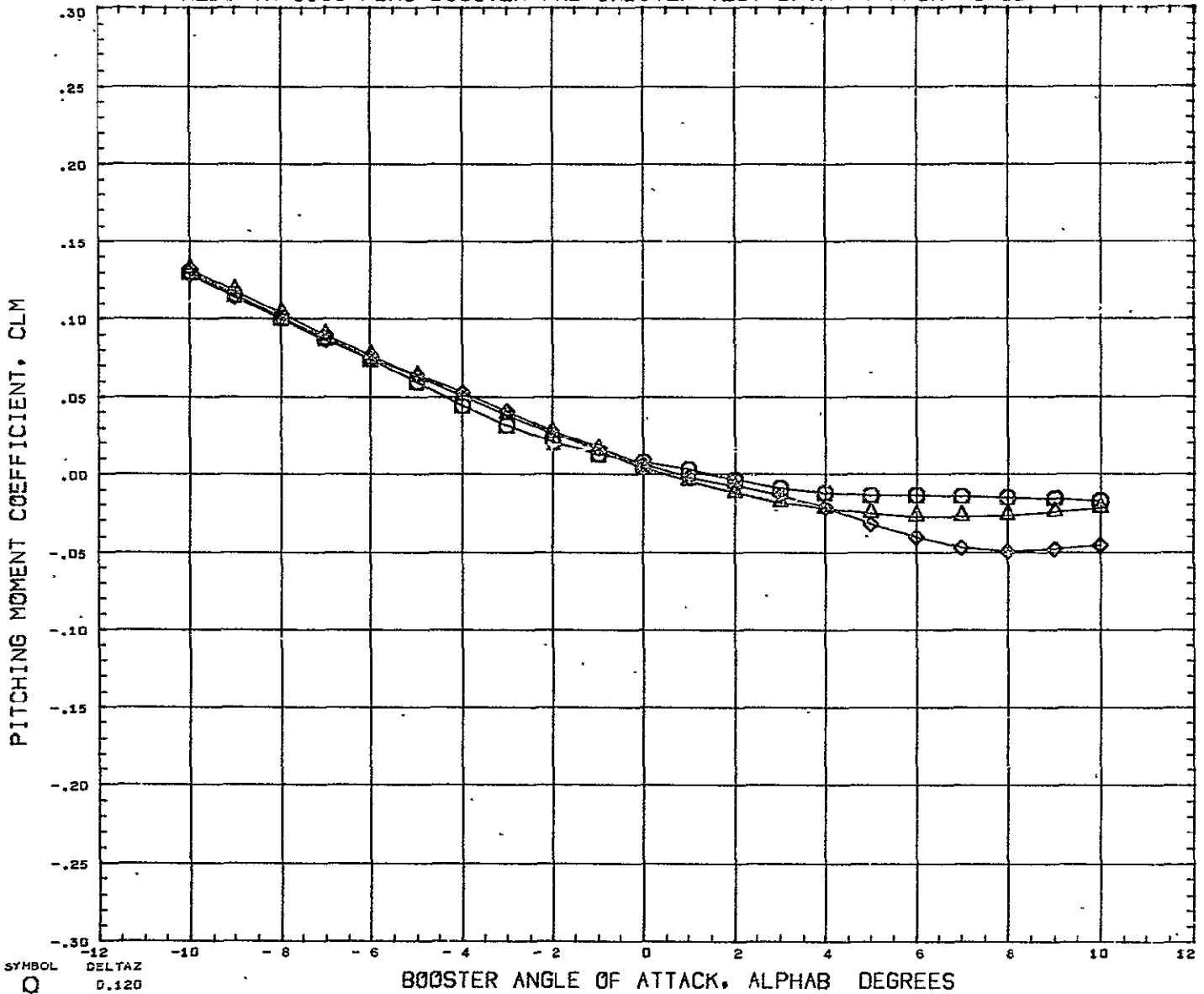

SYMBOL ○ △ ◇	DELTA Z 0.120 0.151 0.182	<b>PARAMETRIC VALUES</b> BSTPOW 100.000    ORBPOW 100.000 DELTAX - 0.019    ALPHAI 0.000 MACH 5.010    ELVBST 20.000 ELVORB - 20.000    BETA 0.000	<b>REFERENCE INFORMATION</b> REFS 23.6890    SQ IN REFL 4.1930    IN REFB 6.5000    IN XMRP 4.9179    IN YMRP 0.0000    IN ZMRP 1.3900    IN SCALE 0.0055
REFERENCE FILE			

# AEDC VA 1163 MDAC BOOSTER AND ORBITER TEST DATA AT MACH NUMBER 5

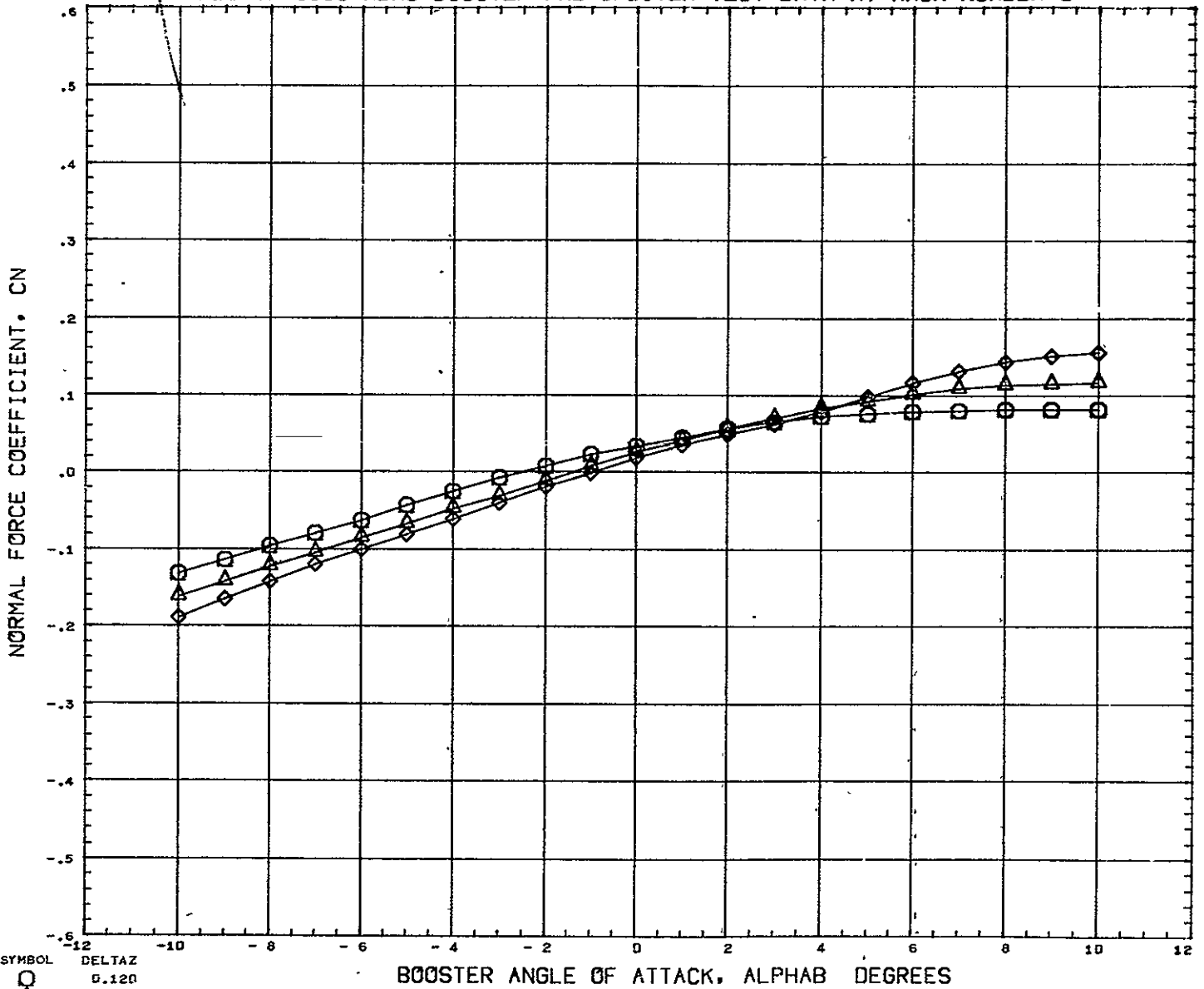

BOOSTER ANGLE OF ATTACK, ALPHAB DEGREES

SYMBOL  
 ○ 0.120  
 △ 0.151  
 ◇ 0.182

PARAMETRIC VALUES  
 BSTPOW 100.000 ORBPOW 100.000  
 DELTAX - 0.010 ALPHAI 0.000  
 MACH 5.010 ELVBST 20.000  
 ELVORB - 20.000 BETA 0.000

REFERENCE INFORMATION  
 .REFS 23.6890 SQ IN  
 REFL 4.1930 IN  
 REFB 6.5000 IN  
 XMRF 4.9170 IN  
 YMRP 0.0000 IN  
 ZMRP 1.3900 IN  
 SCALE 0.0055

01 REFERENCE FILE



# AEDC VA 1163 MDAC BOOSTER AND ORBITER TEST DATA AT MACH NUMBER 5

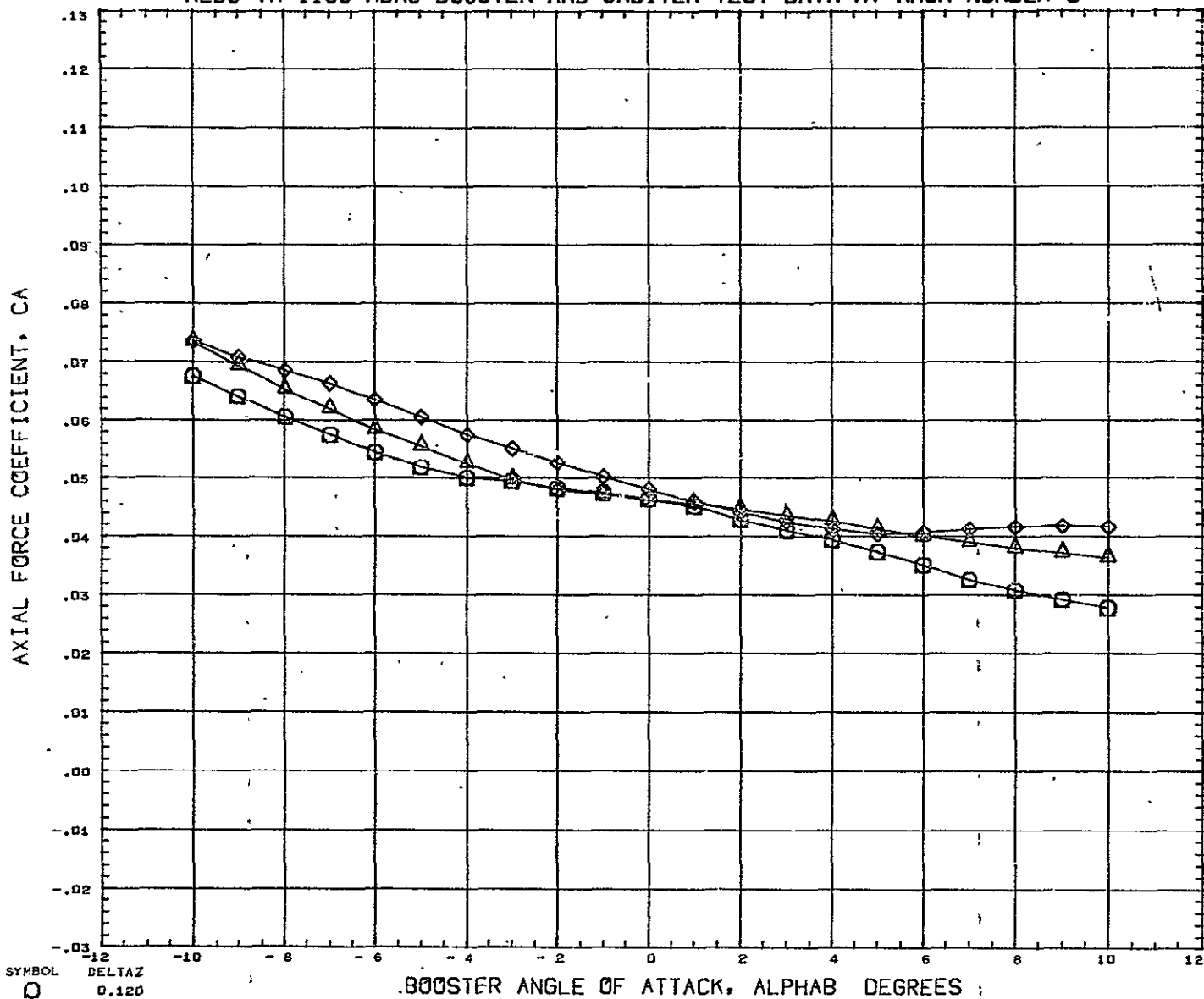

SYMBOL

◇  
△  
□

DELTA Z  
0.120  
0.151  
0.182

BOOSTER ANGLE OF ATTACK, ALPHAB DEGREES :

PARAMETRIC VALUES  
 BSTPOW 100.000 ORBPOW 100.000  
 DELTAX - 0.019 ALPHAI 0.000  
 MACH 5.010 ELVBST 20.000  
 ELVORB - 20.000 BETA 0.000

REFERENCE INFORMATION  
 REFS 23.6690 SQ IN  
 REFL 4.1930 IN  
 REFB 6.5000 IN  
 XMRP 4.9170 IN  
 YMRP 0.0000 IN  
 ZMRP 1.3900 IN  
 SCALE 0.0055

REFERENCE FILE

AEDC VA 1163 MDAC BOOSTER AND ORBITER TEST DATA AT MACH NUMBER 5

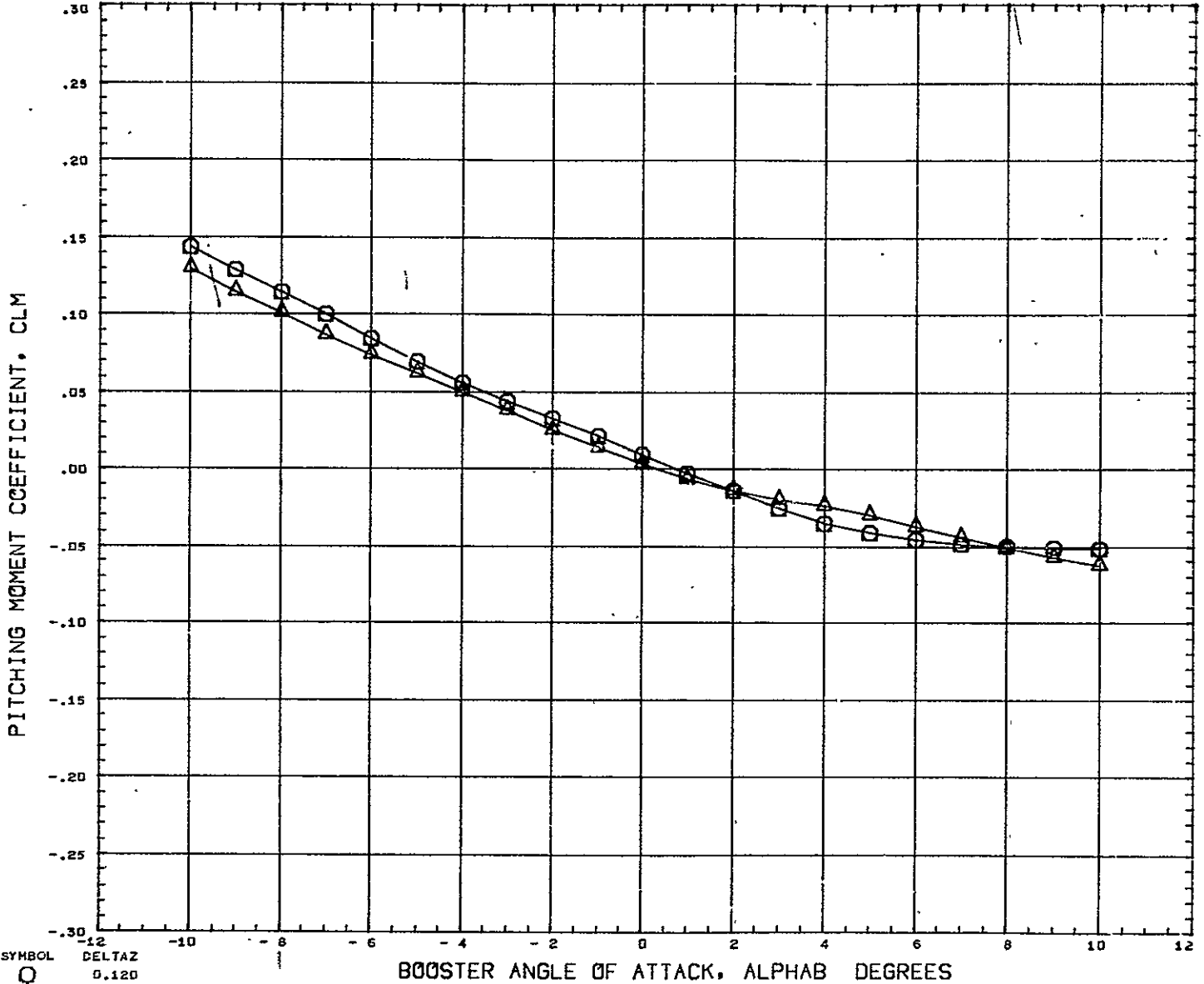

SYMBOL  
 ○  
 △

PARAMETRIC VALUES  
 BSTPOW 100.000 ORBPOW 100.000  
 DELTAX 0.104 ALPHAI 0.000  
 MACH 5.010 ELVBST 20.000  
 ELVORB -20.000 BETA 0.000

REFERENCE INFORMATION  
 REFS 23.6890 SQ IN  
 REFL 4.1930 IN  
 REFB 6.5000 IN  
 XMRP 4.9170 IN  
 YMRP 0.0000 IN  
 ZMRP 1.3900 IN  
 SCALE 0.0055

REFERENCE FILE

# AEDC VA 1163 MDAC BOOSTER AND ORBITER TEST DATA AT MACH NUMBER 5

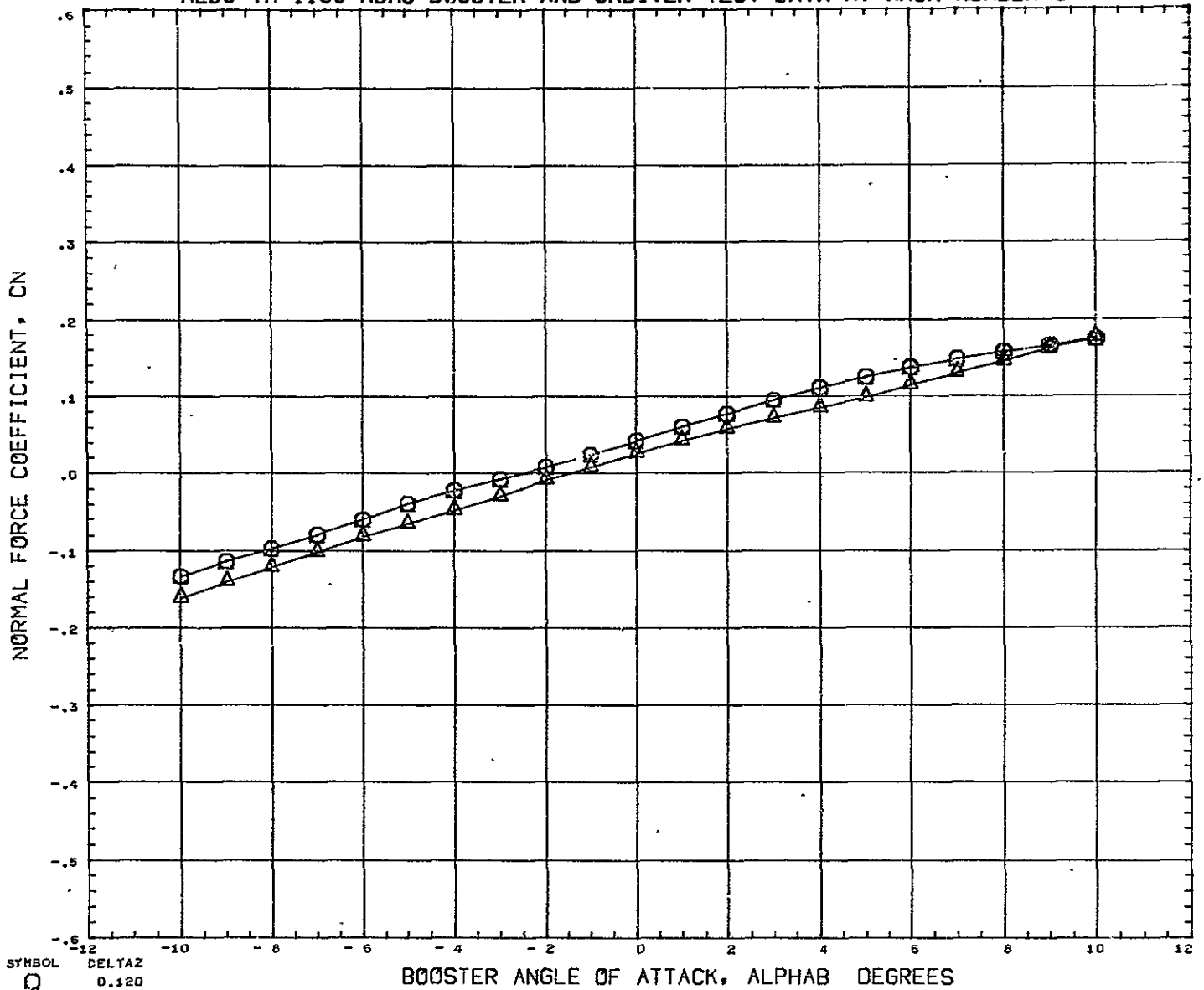

SYMBOL  $\circ$  DELTA Z  
 $\Delta$  0.120  
 0.151

BOOSTER ANGLE OF ATTACK, ALPHA B DEGREES

PARAMETRIC VALUES			
BSTFOW	100.000	ORBPOW	100.000
DELTA X	0.104	ALPHA I	0.000
MACH	5.010	ELVBST	20.000
ELVORB	-20.000	BETA	0.000

REFERENCE INFORMATION		
REFS	23.6890	SQ IN
REFL	4.1930	IN
REFD	6.5000	IN
XMRP	4.9170	IN
YMRP	0.0000	IN
ZMRP	1.3900	IN
SCALE	0.0055	

REFERENCE FILE



# AEDC VA 1163 MDAC BOOSTER AND ORBITER TEST DATA AT MACH NUMBER 5

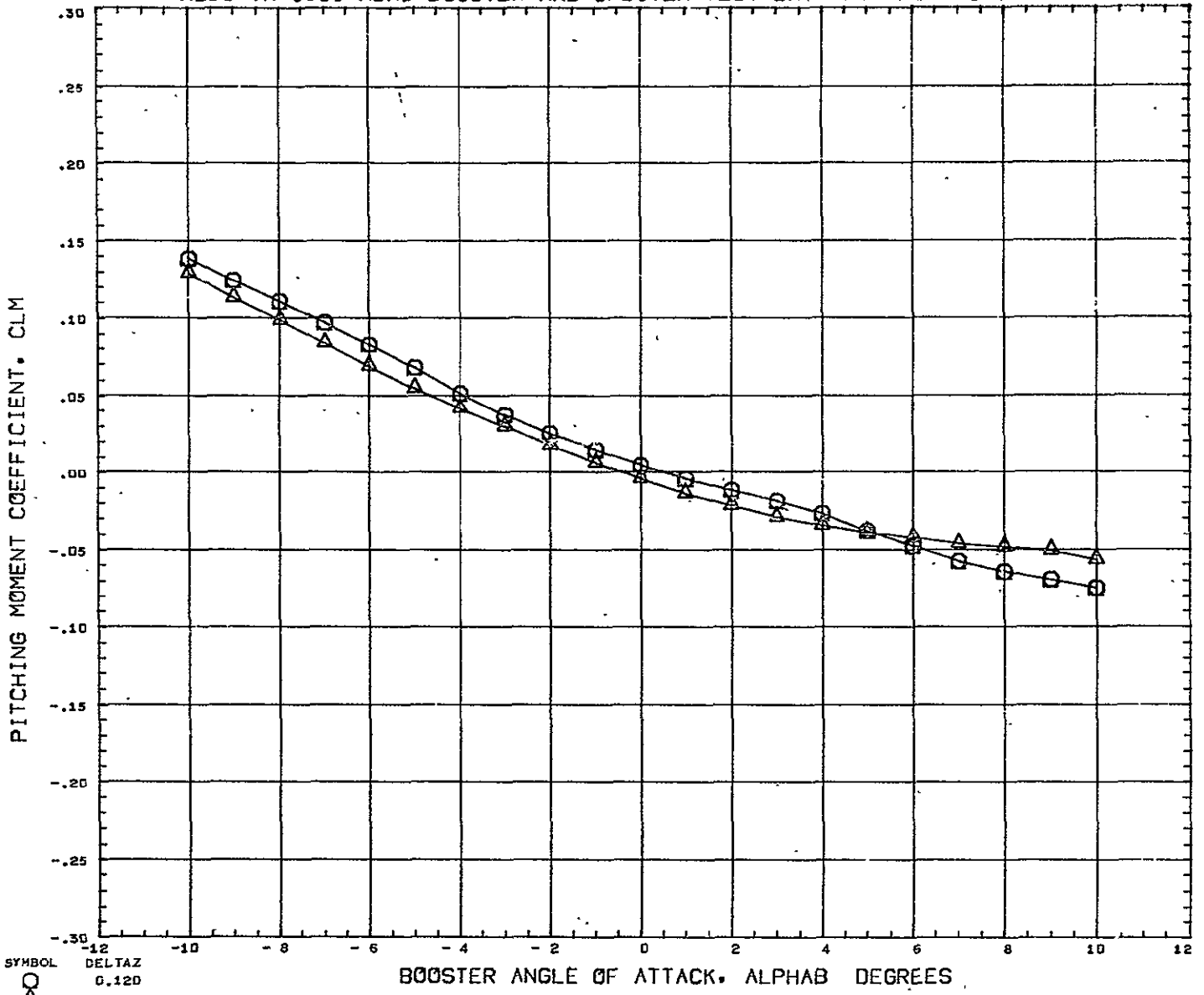

SYMBOL  
 ○ 0.120  
 △ 0.151

BOOSTER ANGLE OF ATTACK, ALPHAB DEGREES

PARAMETRIC VALUES

BSTPOW	100.000	ORBPOW	100.000
DELTAZ	0.167	ALPHA1	0.000
MACH	5.010	ELVBST	20.000
ELVORB	-20.000	BETA	0.500

REFERENCE INFORMATION

REFS	23.6890	SQ IN
REF1	4.1930	IN
REF2	6.5000	IN
XMRP	4.9175	IN
YMRP	0.0000	IN
ZMRP	1.3900	IN
SCALE	0.0055	

REFERENCE FILE

# AEDC VA 1163 MDAC BOOSTER AND ORBITER TEST DATA AT MACH NUMBER 5

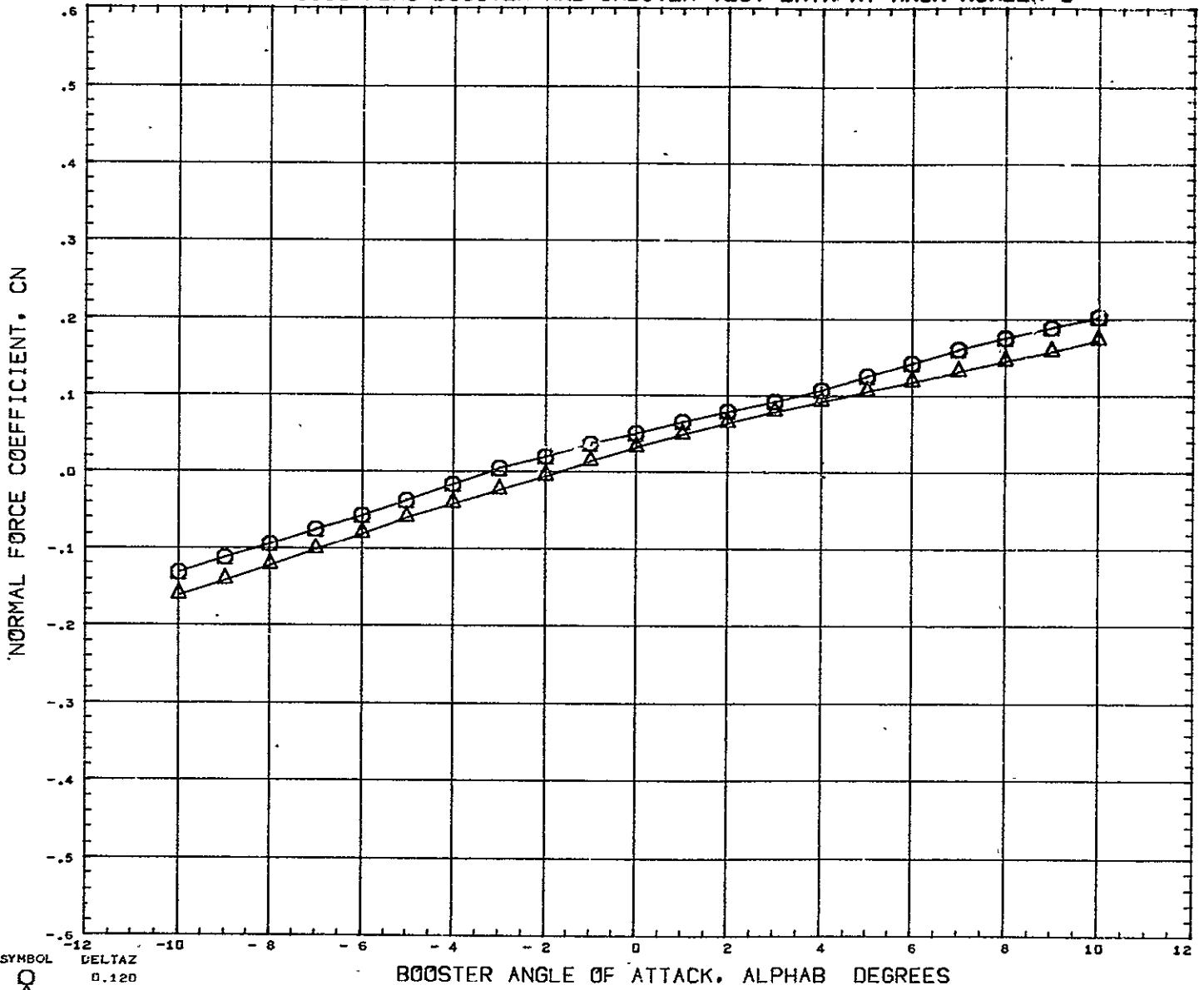

SYMBOL  $\circ$  DELTA Z  
 $\triangle$  0.151

PARAMETRIC VALUES  
 BSTPOW 100.000 ORBPOW 100.000  
 DELTAX 0.167 ALPHAI 0.000  
 MACH 5.010 ELVBST 20.000  
 ELVORB -20.000 BETA 5.000

REFERENCE INFORMATION  
 REFS 23.6890 SQ IN  
 REFL 4.1930 IN  
 REFB 6.5000 IN  
 YMRP 4.9170 IN  
 YMRP 0.0000 IN  
 ZMRP 1.3900 IN  
 SCALE 0.0055

REFERENCE FILE

# AEDC VA 1163 MDAC BOOSTER AND ORBITER TEST DATA AT MACH NUMBER 5

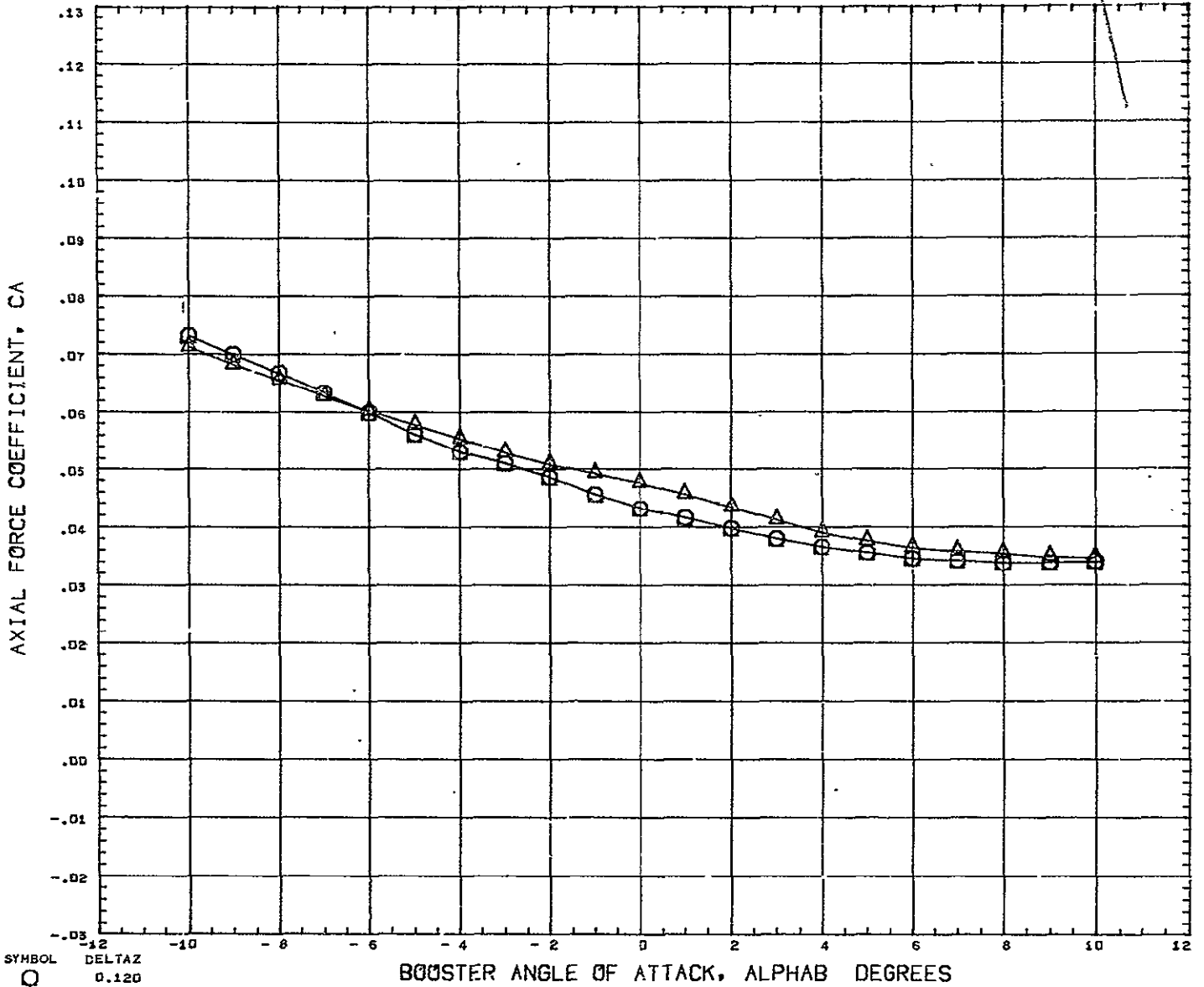

SYMBOL    DELTA Z  
 ○         0.120  
 △         0.151

PARAMETRIC VALUES

BSTPOW	100.000	ORBPOW	100.000
DELTA X	0.167	ALPHA I	0.000
MACH	5.010	ELVBST	20.000
ELVORB	-20.000	BETA	0.000

REFERENCE INFORMATION

REFS	23.6890	SQ	IN
REFL	4.1930	IN	
REFB	6.2000	IN	
XMRP	4.9170	IN	
YMRP	0.0000	IN	
ZMRP	1.3900	IN	
SCALE	0.0055		

REFERENCE FILE

# AEDC VA 1163 MDAC BOOSTER AND ORBITER TEST DATA AT MACH NUMBER 5

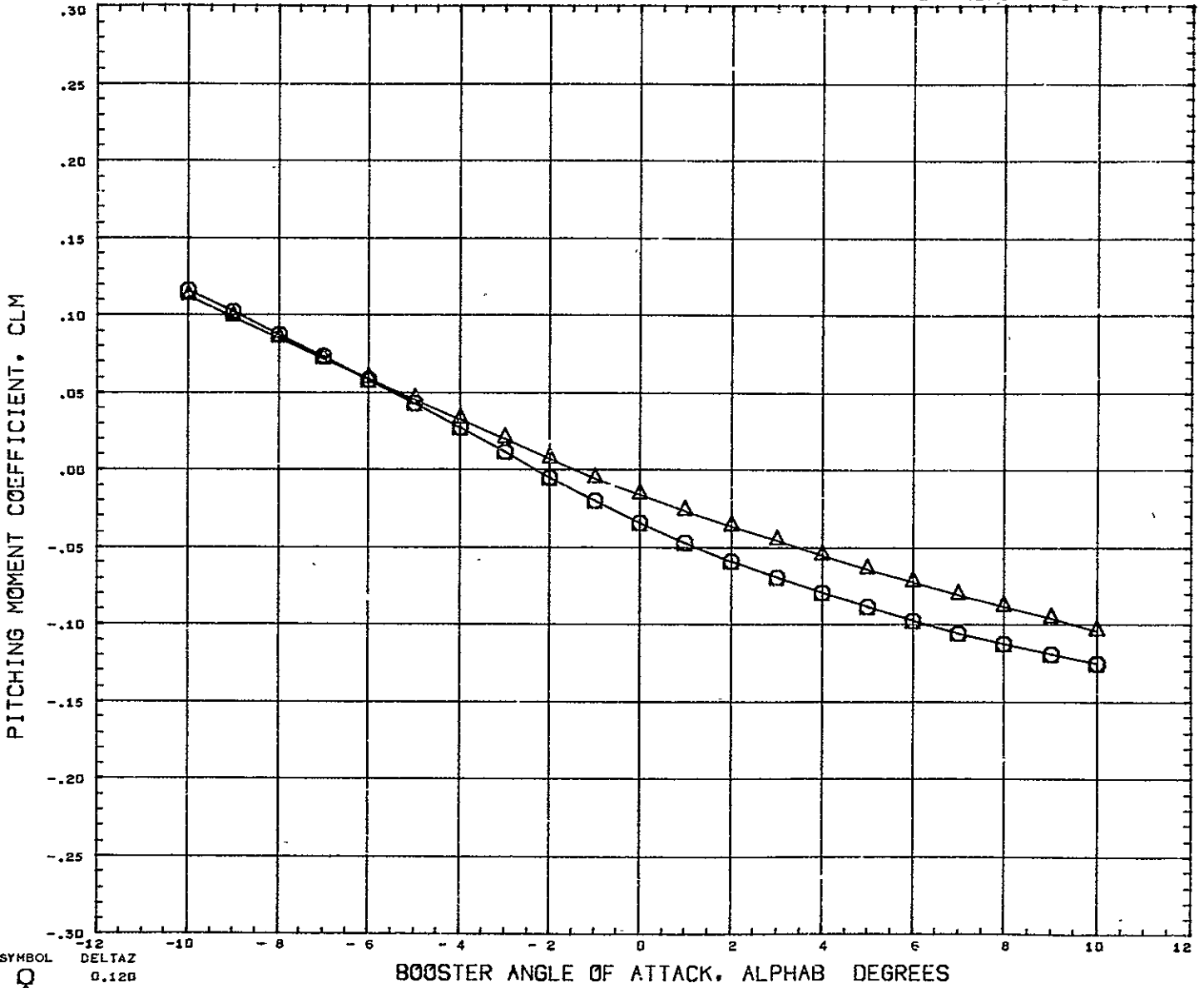

SYMBOL	DELTA Z	BOOSTER ANGLE OF ATTACK, ALPHAB DEGREES		REFERENCE INFORMATION	
□	0.120			REFS	23.6090 SQ IN
△	0.151			REFL	4.1930 IN
		PARAMETRIC VALUES		REFB	6.3000 IN
		BSTPOW	100.000	ORBPOW	100.000
		DELTA X	0.352	ALPHA I	0.000
		MACH	5.010	ELVBST	20.000
		ELVORB	-20.000	BETA	3.000
				XMRP	4.9170 IN
				YMRP	0.0000 IN
				ZMRP	1.3900 IN
				SCALE	0.0055

REFERENCE FILE



# AEDC VA 1163 MDAC BOOSTER AND ORBITER TEST DATA AT MACH NUMBER 5

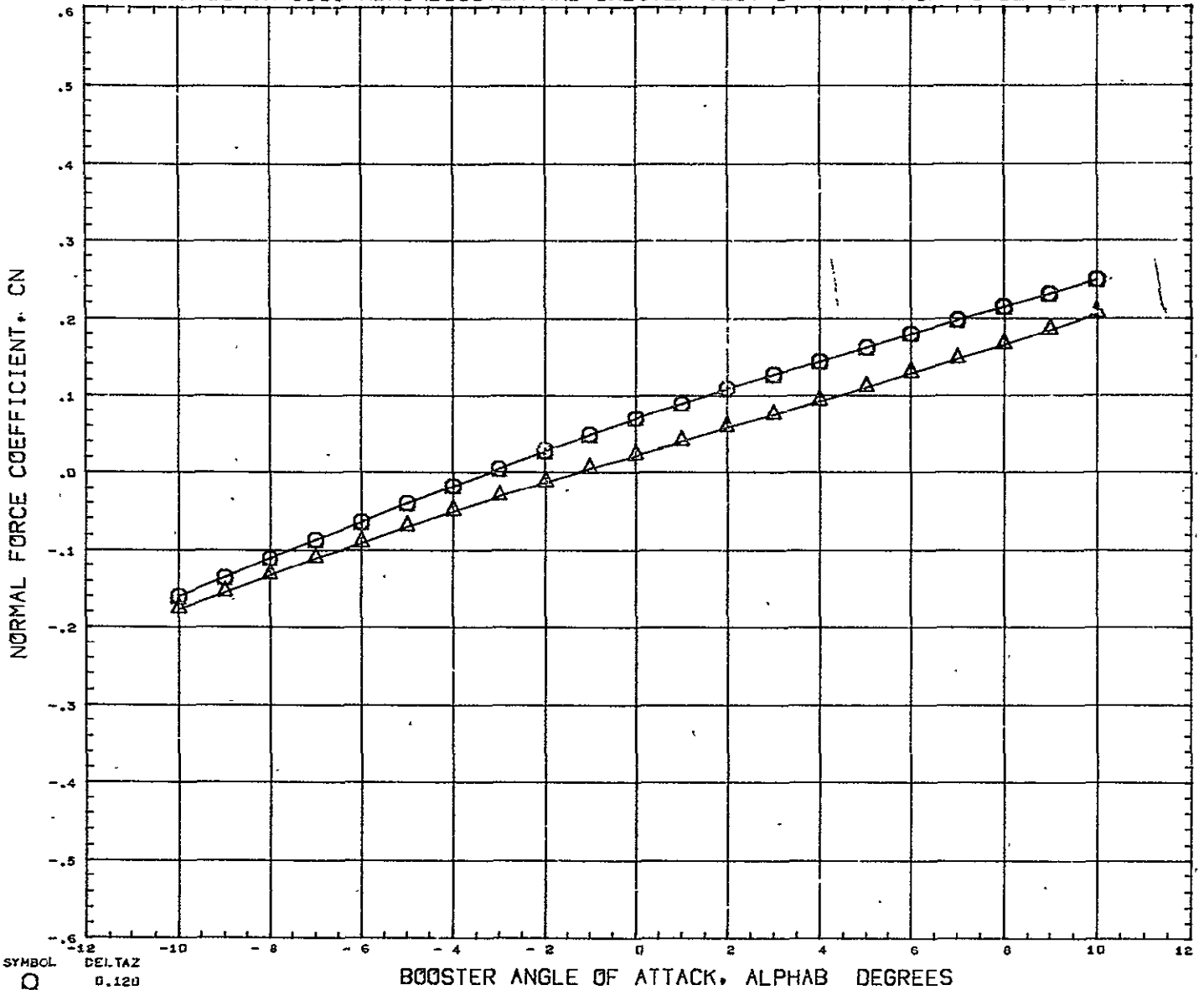

SYMBOL    DELTA Z  
 ○        0.120  
 △        0.151

BOOSTER ANGLE OF ATTACK, ALPHA DEGREES

PARAMETRIC VALUES

BSTPOW	100.000	ORBPOW	100.000
DELTA X	0.352	ALPHA I	0.000
MACH	5.010	ELVBST	20.000
ELVORB	-20.000	BETA	0.000

REFERENCE INFORMATION

REFS	23.6890	SQ IN
REFL	4.1930	IN
REFB	6.5000	IN
XMRP	4.9170	IN
YMRP	0.0000	IN
ZMRP	1.3900	IN
SCALE	0.0055	

REFERENCE FILE

# AEDC VA 1163 MDAC BOOSTER AND ORBITER TEST DATA AT MACH NUMBER 5

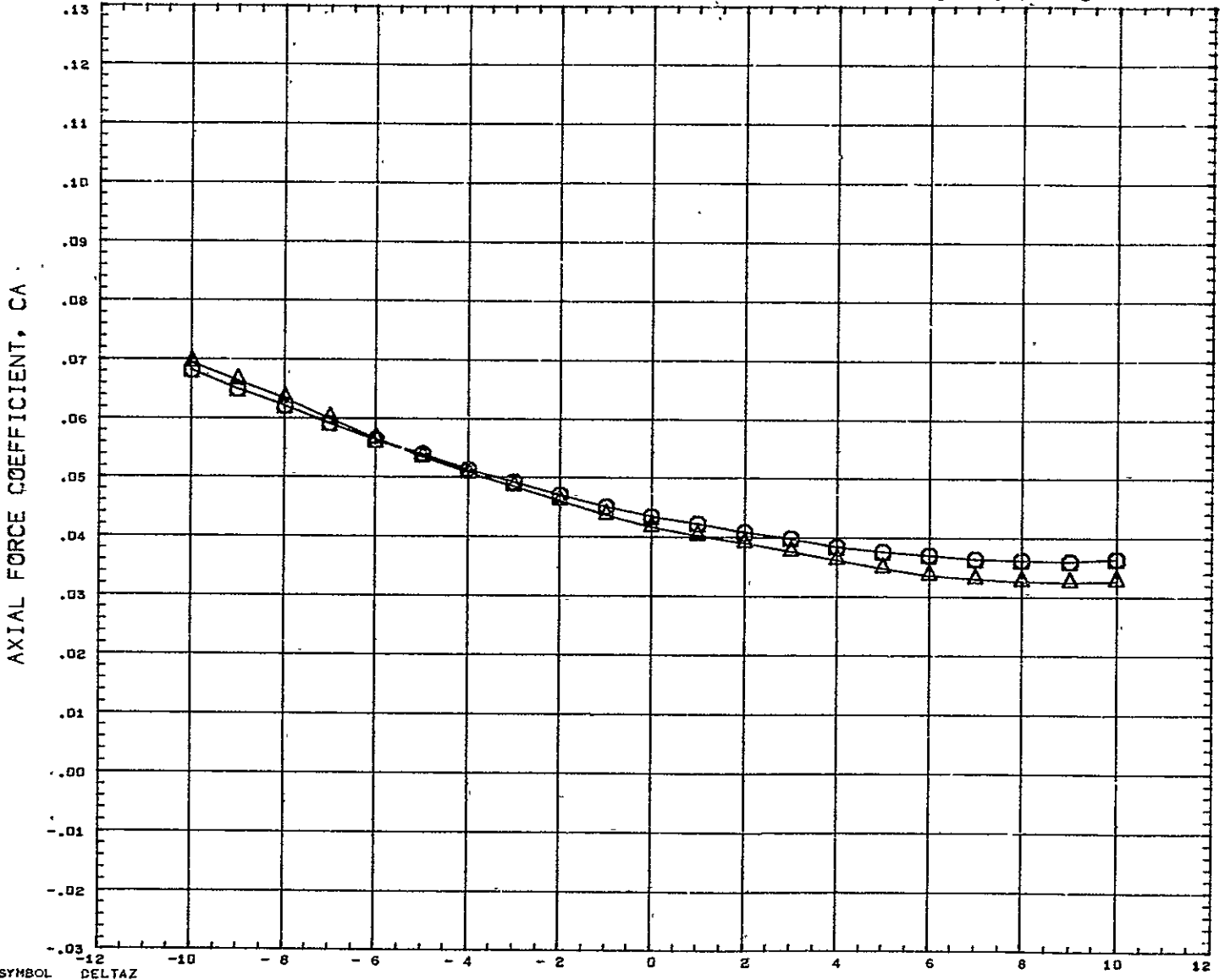

SYMBOL	DELTA Z	PARAMETRIC VALUES	REFERENCE INFORMATION
○	0.120	BSTFOW 100.000 ORBFOW 100.000	REFS 23.6890 SQ IN
△	0.151	DELTA X 0.352 ALPHAI 0.000	REFL 4.1930 IN
		MACH 5.010 ELVBST 20.000	REF6 6.5000 IN
		ELVORB -20.000 BETA 0.000	XMRP 4.9170 IN
			YMRP 0.0000 IN
			ZMRP 1.3900 IN
			SCALE 0.0055
1	REFERENCE FILE		

# AEDC VA 1163 MDAC BOOSTER AND ORBITER TEST DATA AT MACH NUMBER 5

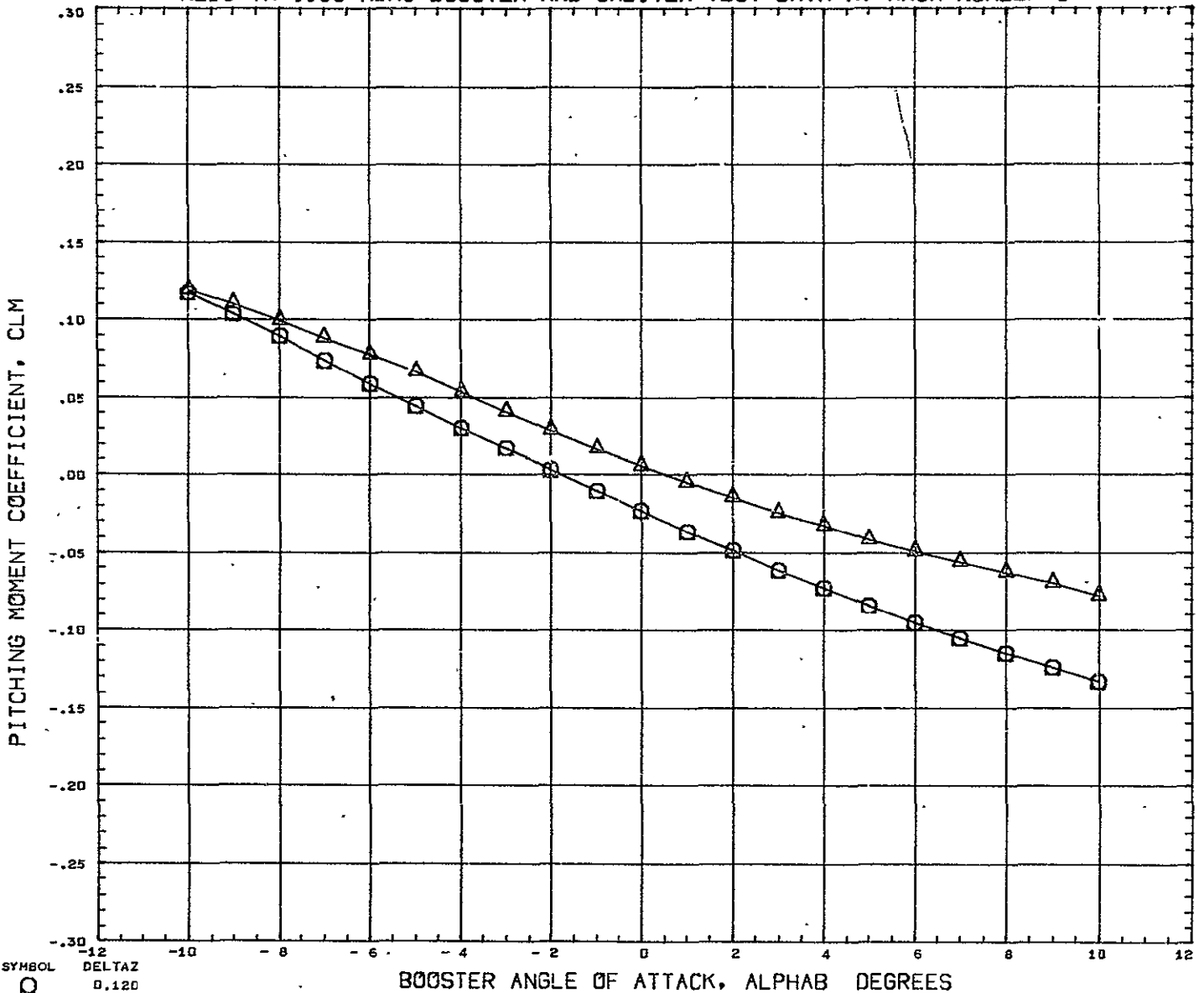

SYMBOL    DELTAZ  
 ○        0.120  
 △        0.151

PARAMETRIC VALUES

BSTPOW	100.000	ORBPOW	100.000
DELTAZ	0.522	ALPHA1	0.000
MACH	5.010	ELVBST	20.000
ELVORB	-20.000	BETA	0.000

REFERENCE INFORMATION

REFS	23.6890	SQ	IN
REFL	4.1930	IN	
REFB	6.5000	IN	
XMRP	4.9170	IN	
YMRP	0.0000	IN	
ZMRP	1.3900	IN	
SCALE	0.0055		

REFERENCE FILE

# AEDC VA 1163 MDAC BOOSTER AND ORBITER TEST DATA AT MACH NUMBER 5

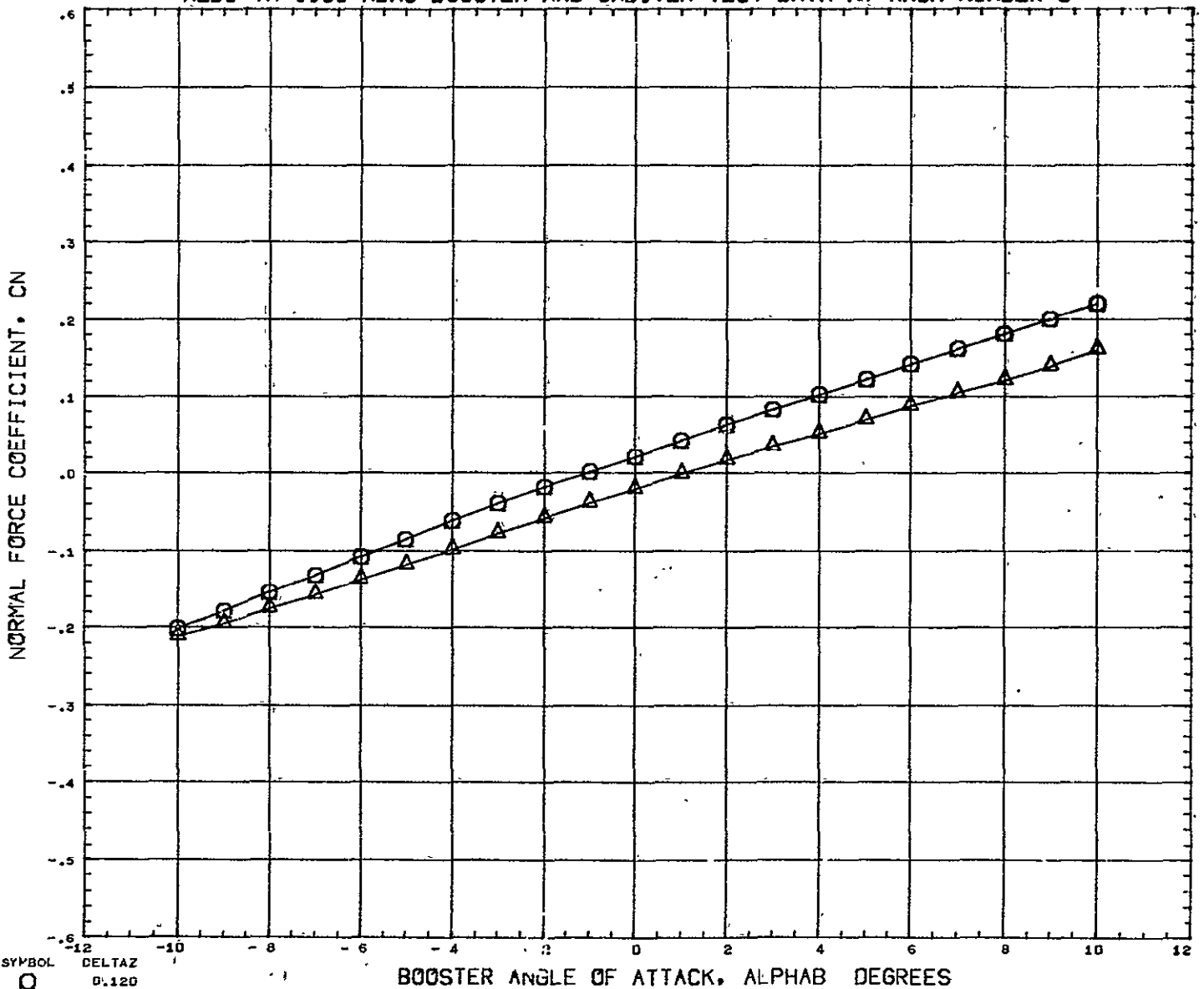

SYMBOL ○ △	DELTAX 0.120 0.151	<b>PARAMETRIC VALUES</b> BSTPOW 100.000 ORBPOW 100.000 DELTAX 0.522 ALPHAI 0.900 MACH 5.010 ELVBST 20.000 ELVORB - 20.000 BETA 0.000	<b>REFERENCE INFORMATION</b> REFS 23.6890 SQ IN REFL 4.1930 IN REFB 6.5000 IN XMRF 4.9170 IN YMRF 0.0000 IN ZMRF 1.3900 IN SCALE 0.0055
------------------	--------------------------	--	--

# AEDC VA 1163 MDAC BOOSTER AND ORBITER TEST DATA AT MACH NUMBER 5

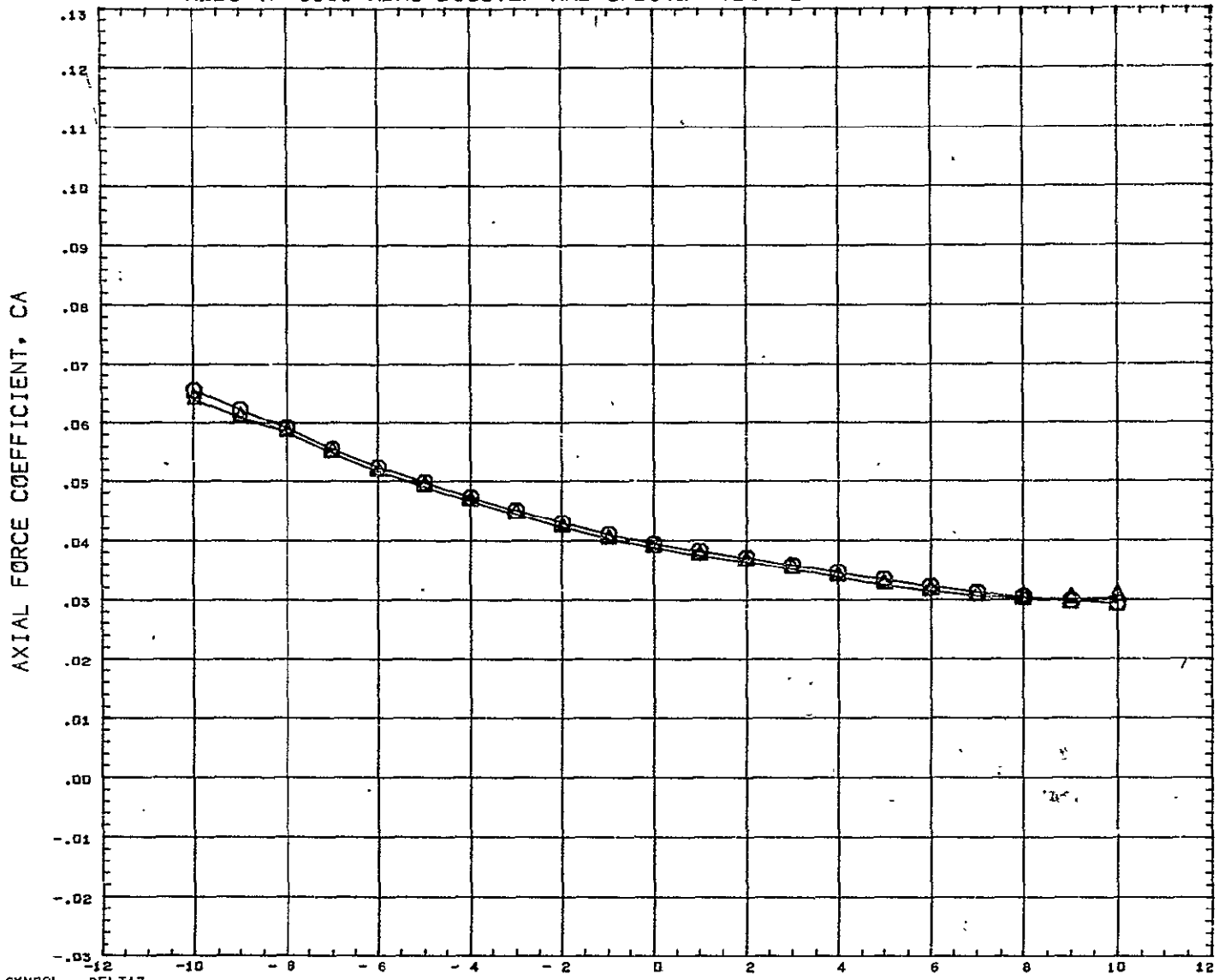

SYMBOL  $\Delta$   
 DELTAZ 0.120  
 D.151

BOOSTER ANGLE OF ATTACK, ALPHAB DEGREES

PARAMETRIC VALUES			
BSTPOW	100.000	ORBPOW	100.000
DELTAZ	0.522	ALPHA1	0.000
MACH	5.010	ELVBST	20.000
ELVORB	-20.000	BETA	0.000

REFERENCE INFORMATION		
REFS	23.6890	SQ IN
REFL	4.1930	IN
REFB	6.5000	IN
XMRP	4.9170	IN
YMRP	-0.0000	IN
ZMRP	1.3900	IN
SCALE	0.0055	

REFERENCE FILE .

## SUMMARY

This report presents aerodynamic data obtained from a joint Langley Research Center (LaRC)/Marshall Space Flight Center (MSFC) Space Shuttle abort stage separation wind tunnel test. The .00556 scale models of the McDonnell-Douglas orbiter and booster configurations were tested in close proximity using dual balances in Tunnel A of the Von Karman Facility (VKF), Arnold Engineering Development Center (AEDC) during the time period of April 21 to April 27, 1971. Data were obtained for both booster and orbiter over an angle of attack range from  $-10^{\circ}$  to  $10^{\circ}$  for zero degree sideslip angle. The models were tested at several relative incidence angles and separation distances and power conditions. Plug nozzles utilizing air were used to simulate booster and orbiter plumes at various altitudes along a nominal ascent trajectory. Powered conditions were 100, 50, 25 and 0 percent of full power for the orbiter and 100, 50 and 0 percent of full power for the booster. Pitch control effectiveness data were obtained for both booster and orbiter with power on and off. In addition, launch vehicle data with and without booster power were obtained utilizing a single balance in the booster model. Data were also obtained with the booster canard off in close proximity and for the launch configuration.

Plotted data for this test will be published under one data report number (DMS-DR-1108) with seven volumes as described below:

<u>Volume</u>	<u>Description</u>
I	Mach Number 5 Booster Proximity Data
II	Mach Number 5 Orbiter Proximity Data
III	Mach Number 3 Booster Proximity Data
IV	Mach Number 3 Orbiter Proximity Data
V	Mach Number 2 Booster Proximity Data
VI	Mach Number 2 Orbiter Proximity Data
VII	Interference Free Data for Orbiter and Booster, Launch Vehicle Data, and Proximity Data for Mach Numbers 4 and 6.

A report containing Schlieren photographs will be published by AEDC. Schlieren photographs were taken at  $-10^{\circ}$ ,  $0^{\circ}$ , and  $10^{\circ}$  degrees angles of attack for each pitch polar.