

2
MIX

DMS-DR-11
SEPTEMBER 19
CR-119976

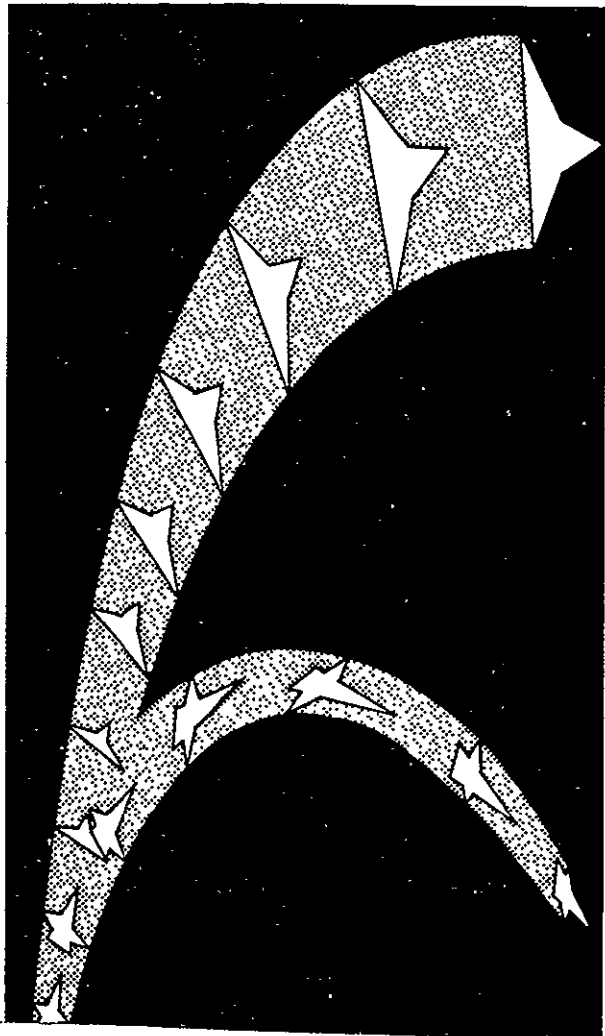

—SPACE SHUTTLE—

**AERODYNAMIC CHARACTERISTICS
OF THE NR DELTA WING ORBITER
M=0.6 - 1.3**

by

C. Donald Andrews, LMSC/HREC

**MSFC 14-INCH
TRISONIC WIND TUNNEL**

FACILITY FORM 602	171-38677	
	(ACCESSION NUMBER)	(THRU)
	59	C3
	(PAGES)	(CODE)
	CR-119976	31
	(NASA CR OR TMX OR AD NUMBER)	(CATEGORY)

**MARSHALL
SPACE FLIGHT CENTER**

SADSAC SPACE SHUTTLE
AEROTHERMODYNAMIC
DATA MANAGEMENT SYSTEM

N A S A

CONTRACT NAS8-4016
MARSHALL SPACE FLIGHT CENTER

Reproduced by
**NATIONAL TECHNICAL
INFORMATION SERVICE**
U S Department of Commerce
Springfield VA 22151



SADSAC/SPACE SHUTTLE
WIND TUNNEL TEST DATA REPORT

CONFIGURATION: North American Delta Wing Orbiter Space Shuttle

TEST PURPOSE: Force and Static Stability Investigation of 0.0035 Scale NR
Delta Wing Orbiter at Mach Numbers of 0.4 to 1.3

TEST FACILITY: MSFC 14 x 14 Inch Trisonic Wind Tunnel

TESTING AGENCY: Lockheed for MSFC

TEST NO. & DATE: MSFC TWT 477; January 1971

FACILITY COORDINATOR: J. Weaver - MSFC

PROJECT ENGINEER(S): C. Donald Andrews - Lockheed

DATA MANAGEMENT SERVICES

LIAISON: N/A DATA OPERATIONS: *John Hord*
John Hord
Aero Thermo Data Group

RELEASE APPROVAL: *J. J. Glynn*
FORN. D. Kemp, Supervisor
Aero Thermo Data Group

FACILITY COORDINATOR:

Mr. Jim Weaver
Marshall Spaceflight Center
Mail Stop S&E-AERO-AAE
Huntsville, Alabama 35801

Phone: (205) 453-2512

PROJECT ENGINEER:

Mr. C. Donald Andrews
Department 5420
Lockheed Huntsville
Research and Engineering Center
P. O. Box 1103, West Station
Huntsville, Alabama 35807

Phone: (205) 837-1800-X378

SADSAC OPERATIONS:

Mr. John Hord
Chrysler Corp. Space Division
Department 2780
P. O. Box 29200
New Orleans, Louisiana 70129

Phone: (504) 255-2304

ABSTRACT

A 0.0035 scale model of the North American Delta Wing Orbiter was tested in the MSFC 14 Inch Trisonic Wind Tunnel (Test No. MSFC TWT 477) during January 1971 to obtain force and static stability data at Mach Numbers of 0.4 to 1.3. The model was tested at angle of attack ranges of 0 to 20, 20 to 40, 40 to 60, and 50 to 70 degrees at zero degree sideslip; all control surface deflections were zero for this test.

THIS PAGE INTENTIONALLY LEFT BLANK

TABLE OF CONTENTS

	<u>PAGE NUMBER</u>
LIST OF FIGURES	2
LIST OF TABLES	3
SUMMARY	4
NOMENCLATURE SUMMARY	5
CONFIGURATIONS INVESTIGATED.	6
DATASET COLLATION SHEET	7
TEST FACILITY DESCRIPTION.	8
TEST CONDITIONS	9
DATA REDUCTION	10
SUMMARY DATA PLOT INDEX.	12
FIGURES.	13
MODEL COMPONENT DESCRIPTION SHEETS	19
NOMENCLATURE	23
TABULATED DATA LISTING	28
PLOTTED DATA	29

LIST OF FIGURES

<u>Number</u>	<u>Title</u>	<u>Page</u>
1	Axis Systems	13
2	North American Rockwell Delta Wing Orbiter	14
3	Body B5 9992-134B Configuration	15
4	Wing W17 9992-134D Configuration	16
5	Elevon, E10 - Elevon Used with Wing W17	17
6	Vertical Stabilizer V17	18

LIST OF TABLES

<u>TABLE NUMBER</u>	<u>TITLE</u>	<u>PAGE NUMBER</u>
I	Summary of SADSAC Nomenclature-Aerodynamic Force and Moment Coefficients	5
II	Test MSFC-TWT 477 Dataset Collation Sheet	7
III	Test Conditions	9
IV	Summary Data Plot Index	12
V	Model Component: Body - B ₅	19
VI	Model Component: Wing - W ₁₇	20
VII	Model Component: Elevon - E ₁₀	21
VIII	Model Component: Vertical Stabilizer - V ₁₇	22

SUMMARY

A 0.0035 scale model of the North American Delta Wing Orbiter was tested in the MSFC 14 Inch Transonic Wind Tunnel (Test No. MSFC TWT 477) during January 1971 to obtain force and static stability data at Mach Numbers of 0.4 to 1.3. The model was tested at angle of attack ranges of 0 to 20, 20 to 40, 40 to 60, and 50 to 70 degrees at zero degree sideslip; all control surface deflections were zero for this test.

TABLE I SUMMARY OF SADSAC NOMENCLATURE - AERODYNAMIC FORCE AND MOMENT COEFFICIENTS

COEFFICIENT	COEFFICIENT NAME	SADSAC NOMENCLATURE		
		BODY AXIS	STABILITY AXIS	WIND AXIS
C_A	Total Axial Force	CA	-	-
C_{AB}	Base Axial Force	CAB	--	-
C_{AF}	Forebody Axial Force	CAF	-	-
C_D	Total Drag Force	-	C_D	CDTOTL
C_{DB}	Base Drag Force	-	C_{DB}	CDBASE
C_{DF}	Forebody Drag Force	-	C_{DF}	CDFORE
C_L	Lift Force	-	C_L	CL
C_N	Normal Force	CN	-	-
C_Y	Side Force	CY	CY	CC
C_l	Rolling Moment	CBL	CSL	CWL
C_m	Pitching Moment	CLM	CLM	CPM
C_n	Yawing Moment	CYN	CLN	CLN
L/D	Lift-To-Drag Force Ratio	-	L/D	CL/CD
L/D	Lift-To-Forebody Drag Force Ratio	-	L/DF	CL/CDF
N/A	Normal-To-Axial Force Ratio	N/A	-	-
N/A	Normal-To-Forebody Axial Force Ratio	CN/CAF	-	-

CONFIGURATIONS INVESTIGATED

NOMENCLATURE

B ₅	=	NR Delta Wing Orbiter Body
W ₁₇	=	Delta Wing
E ₁₀	=	Elevon for Delta Wing W ₁₇
V ₁₇	=	Vertical Stabilizer
X	=	Balance Adapter Extension

COMBINATIONS TESTED

Only one combination was tested; this was configuration B5W17E10V17X. This configuration was tested at Mach Numbers of 0.4 to 1.3, angle of attack ranges of 0 to 20, 20 to 40, 40 to 60, and 50 to 70 at zero degree sideslip.

TABLE II. TEST MSFC-TWT477 DATA SET COLLATION SHEET

PRETEST
 POSTTEST

DATA S-T IDENTIFIER	CONFIGURATION	SCH. NO.		CONTROL DEFLECTION			NO. of RUNS	MACH NUMBERS						
		α	β	S_e					1.4	0.6	0.9	1.0	1.1	1.2
R2600A	B5W17E10V17X	A	0	0			7	00%	002%	003%	004%	005%	006%	007%
R2600B	↓	B	0	0			7	008%	009%	010%	011%	012%	013%	014%
R2600C	↓	C	0	0			7	015%	016%	017%	018%	019%	020%	021%
R2600D	B5W17E10V17X	D	0	0			7	022%	023%	024%	025%	026%	027%	028%

1 7 13 19 25 31 37 43 49 55 61 67 75 76

CLM CL CLN CY CSL CAB CDE XCP 8

COEFFICIENTS:

α or β

SCHEDULES

A $\alpha = 0$ to 20 D $\alpha = 50$ to 70
 B $\alpha = 20$ to 40
 C $\alpha = 40$ to 60

⇒ IDPVAR(1) | IDPVAR(2) | NDV

TEST FACILITY DESCRIPTION

The Marshall Space Flight Center 14" x 14" Trisonic Wind Tunnel is an intermittent blowdown tunnel which operates by high pressure air flowing from storage to either vacuum or atmospheric conditions. A Mach number range from .2 to 5.85 is covered by utilizing two interchangeable test sections. The transonic section permits testing at Mach 0.20 through 2.50, and the supersonic section permits testing at Mach 2.74 through 5.85. Mach numbers between .2 and .9 are obtained by using a controllable diffuser. The range from .95 to 1.3 is achieved through the use of plenum suction and perforated walls. Mach numbers of 1.44, 1.93 and 2.50 are produced by interchangeable sets of fixed contour nozzle blocks. Above Mach 2.50 a set of fixed contour nozzle blocks are tilted and translated automatically to produce any desired Mach number in .25 increments.

Air is supplied to a 6000 cubic foot storage tank at approximately -40°F dew point and 500 psi. The compressor is a three-stage reciprocating unit driven by a 1500 hp motor.

The tunnel flow is established and controlled with a servo actuated gate valve. The controlled air flows through the valve diffuser into the stilling chamber and heat exchanger where the air temperature can be controlled from ambient to approximately 180°F . The air then passes through the test section which contains the nozzle blocks and test region.

Downstream of the test section is a hydraulically controlled pitch sector that provides a total angle of attack range of 20° ($\pm 10^{\circ}$). Sting offsets are available for obtaining various maximum angles of attack up to 25° .

DATA REDUCTION

Force and moment data were measured by a six-component internal strain gauge balance and the measured data were reduced to coefficient form in both the body and stability axis systems. The angle of attack data were corrected for sting and balance deflections and the axial force was corrected for weight tares. Since the balance was inclined 1.5 degrees to the model centerline, the coefficients were initially computed and referenced to the balance axis system and then transferred to the body axis system. Dimensional data applicable to the reduction of the body and stability axis systems data to coefficient form are listed below:

<u>Symbol</u>	<u>Description</u>	<u>Full Scale</u>	<u>Model Scale</u>
S_{ref}	Wing area	6084.0 ft ²	0.074529 ft ²
l_{ref}	Wing MAC	821.2 in.	2.8742 in.
b_{ref}	Wing Span	1422.8 in.	4.9798 in.
XMRP	MRP X location	1422.5 in.	4.97875 in.
YMRP	MRP Y location	0.0 in.	0.0 in.
ZMRP	MRP Z location	130.0 in.	0.455 in.
A_b	Base Area	----	0.005488 ft ²
l_B	Body Length	2120 in.	7.42 in.

The moment reference point (MRP) information listed above is referenced to the nose of the fuselage for XMRP, the lateral centerline for YMRP, and waterline zero for ZMRP; waterline zero is at the bottom of the fuselage. The dimensional data listed above will not always agree with the data on the component

sheets; the dimensional data listed above are the same as the dimensional data utilized for test MSFC TWT 468 and AEDC-PWT-TC135.

Coefficient data input into the SADSAC data deck are CLM, CDF, CAB, CLN, CY, CSL, CL and XCP; coefficients not defined in the section on NOMENCLATURE (this report) are defined below.

$$CAB = -((0.5(P_{b1} + P_{b2}) - P) / q) (A_b / S_{ref})$$

CAB = base axial force coefficient

P_{b1} = right side base pressure

P_{b2} = left side base pressure

$$XCP = (XMRP - (CLM \times l_{ref}) / CN) / l_B$$

XCP = center of pressure, based on body length.

TABLE IV. SUMMARY DATA PLOT INDEX

TITLE	PLOTTED COEFFICIENTS SCHEDULE	CONDITIONS VARYING	PAGES
MSFC TWT 477 NR Delta Wing Orbiter Data	A & B	Mach Number	1-56

PLOTTED COEFFICIENTS SCHEDULE:

- (A) CL, CAB, XCP/L, L/DF, CDF, CIM vs. Alpha
- (B) CL vs. CIM, CL vs. CDF

Notes:

1. Positive directions of force coefficients, moment coefficients, and angles are indicated by arrows.
2. For clarity, origins of wind and stability axes have been displaced from the center of gravity.

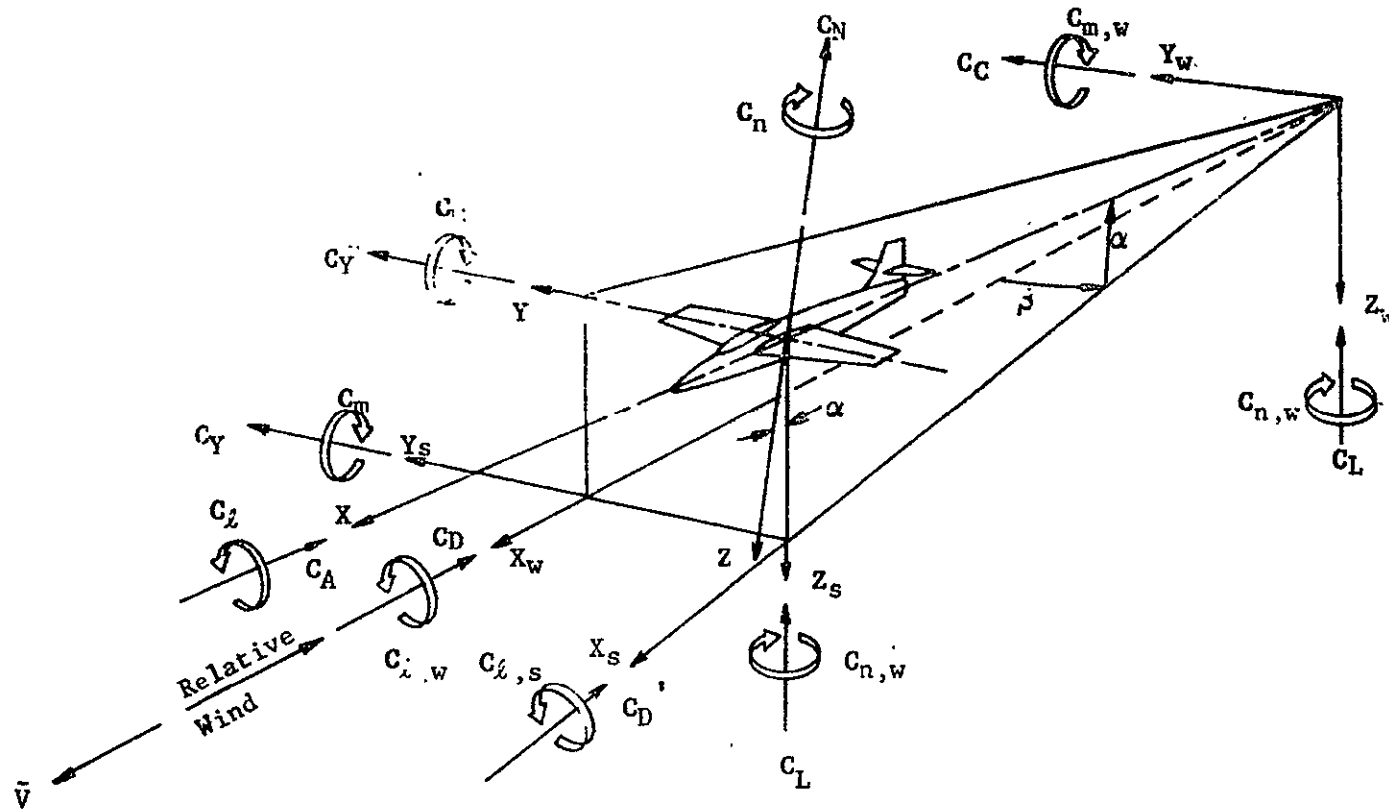

Figure 1. Axis systems, showing direction and sense of force and moment coefficients, angle of attack, and sideslip angle

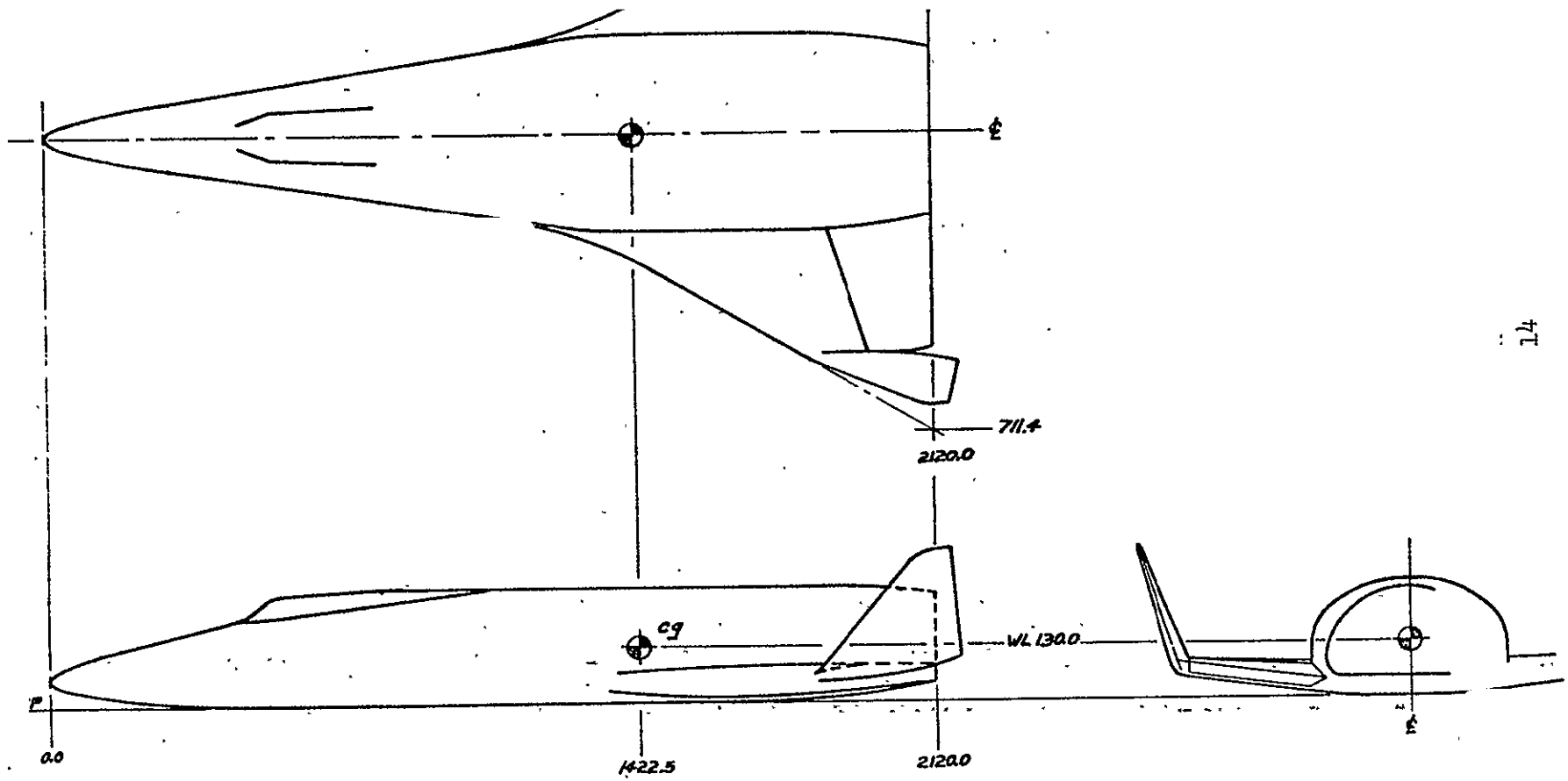

Figure 2. North American Rockwell Delta Wing Orbiter

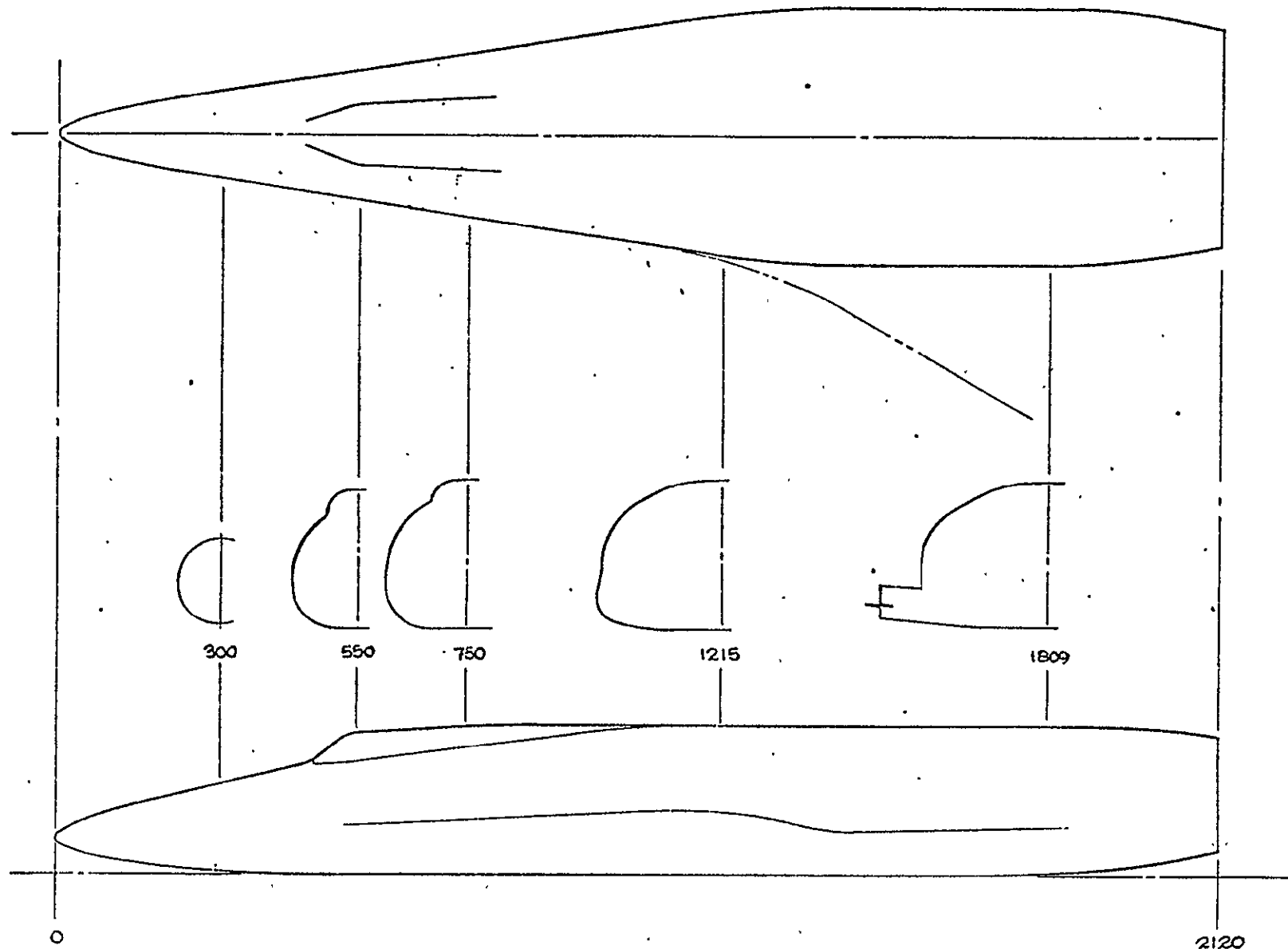

FIGURE 3. BODY B5 9992-134 B CONFIGURATION

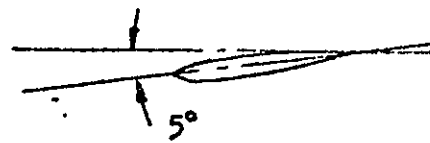
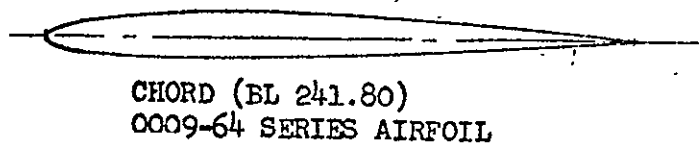
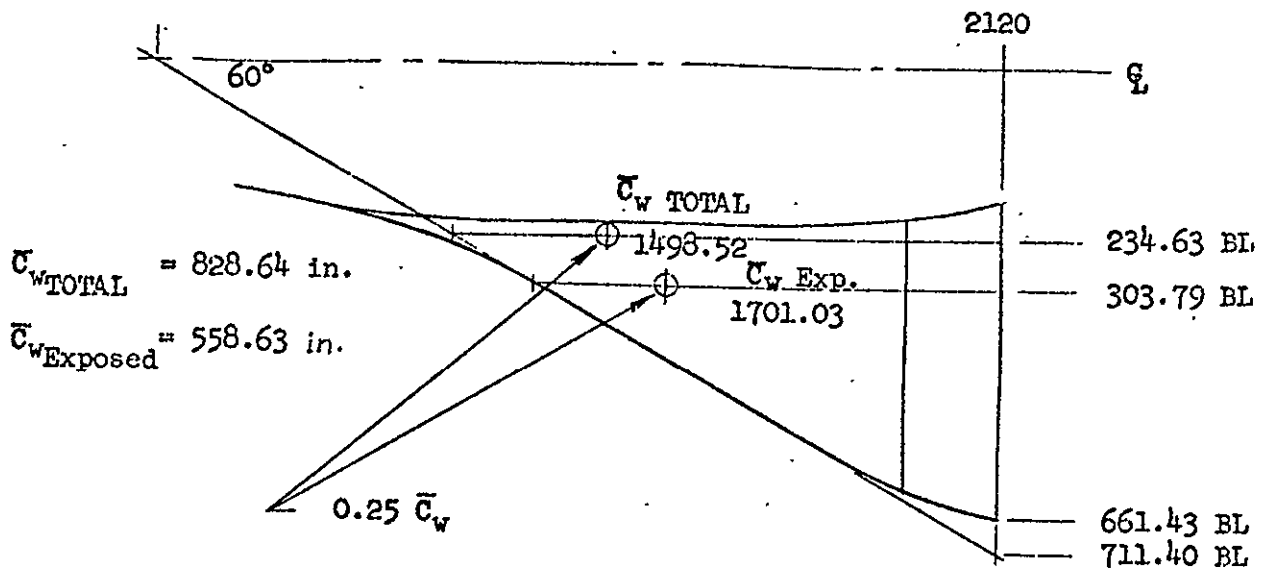

FIGURE 4. WING W_{17} 9992-134 D Configuration

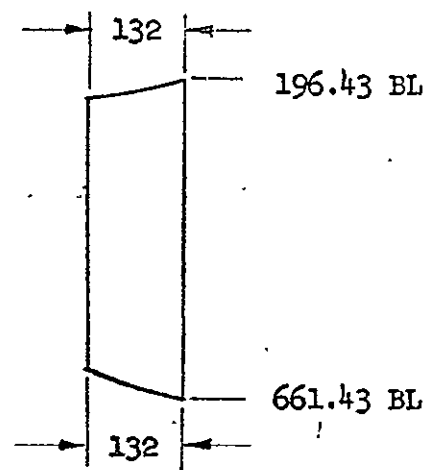

FIGURE 5. ELEVON, E 10-ELEVON USED WITH WING W17

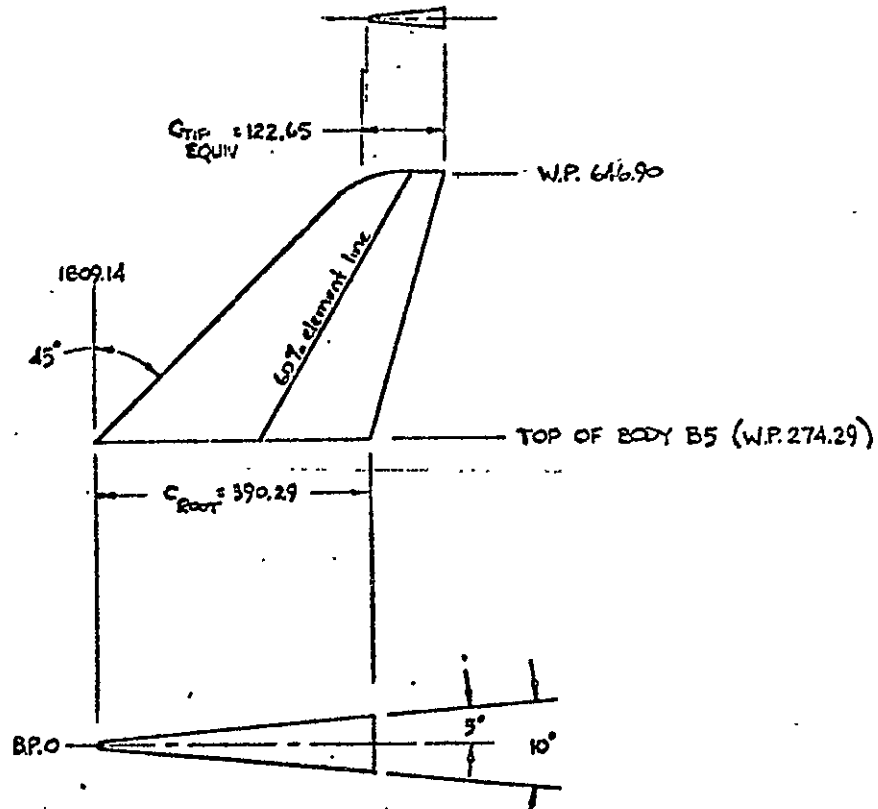

Figure 6. Vertical Stabilizer V₁₇

TABLE V

MODEL COMPONENT: BODY - B5

GENERAL DESCRIPTION: 9992-134B body. Delta wing orbiter body including a canopy on the upper surface aft of the nose. The model scale factor is 0.0035

DRAWING NUMBER: Lines Dwg. 9992-134B

<u>DIMENSIONS:</u>	<u>FULL-SCALE</u>	<u>MODEL SCALE</u>
Length	<u>2120.00</u>	<u>7.420</u>
Max. Width	<u>462.86</u>	<u>1.620</u>
Max. Depth	<u>274.29</u>	<u>0.960</u>
Fineness Ratio	<u>5.906</u>	<u>5.906</u>
Area		
Max. Cross-Sectional, ft ² (Fus. Sta. 1215.0 to 1809.0 in.)	<u>702.75</u>	<u>0.00860</u>
Planform	<u>-</u>	<u>-</u>
Wetted	<u>-</u>	<u>-</u>
Base	<u>-</u>	<u>-</u>

MODEL COMPONENT: Wing-W17

GENERAL DESCRIPTION: Delta wing with -5° twist and rounded wing tips. Wing blends into body. Follows NB lines drawing 9992-134D.

Model Scale = 0.0035

DRAWING NUMBER:

S-865-13, -14, -55 thru -60

DIMENSIONS:

	<u>FULL-SCALE</u>	<u>MODEL SCALE</u>
<u>TOTAL DATA</u>		
Area, ft ²		
Planform		
Wetted	<u>6026.60</u>	<u>0.07383</u>
Span (equivalent), in.		
Aspect Ratio	<u>1286.28</u>	<u>4.502</u>
Rate of Taper	<u>1.892</u>	<u>1.892</u>
Taper Ratio	<u>1.723</u>	<u>1.723</u>
Dihedral Angle, degrees	<u>0.094</u>	<u>0.094</u>
Incidence Angle, degrees	<u>7.0</u>	<u>7.0</u>
Aerodynamic Twist, degrees (about T.E)	<u>0.0</u>	<u>0.0</u>
Toe-In Angle	<u>-5.0</u>	<u>-5.0</u>
Cant Angle	<u>-</u>	<u>-</u>
Sweep Back Angles, degrees	<u>-</u>	<u>-</u>
Leading Edge	<u>60.056</u>	<u>60.056</u>
Trailing Edge	<u>0.000</u>	<u>0.000</u>
0.25 Element Line	<u>52.473</u>	<u>52.473</u>
Chords: in.		
Root (Wing Sta. 0.0)	<u>1232.91</u>	<u>4.315</u>
Tip, (equivalent) (W.S. 647.97)	<u>116.45</u>	<u>0.408</u>
MAC (W.S. 234.63)	<u>828.64</u>	<u>2.900</u>
Fus. Sta. of .25 MAC	<u>1498.52</u>	<u>5.245</u>
W.P. of .25 MAC	<u>46.27</u>	<u>0.162</u>
B.L. of .25 MAC	<u>232.88</u>	<u>0.815</u>
Airfoil Section		
Root (W.S. 241.80)	<u>NACA 0009-64</u>	
Tip (W.S. 546.07)	<u>NACA 0012-64</u>	
<u>EXPOSED DATA</u>		
Area, ft ²	<u>2658.68</u>	<u>0.03257</u>
Span, (equivalent) in.	<u>814.61</u>	<u>2.851</u>
Aspect Ratio	<u>1.720</u>	<u>1.720</u>
Taper Ratio	<u>0.141</u>	<u>0.141</u>
Chords: in.		
Root, (Equiv.) (W.S. 237.61)	<u>823.51</u>	<u>2.882</u>
Tip, (Equiv.) (W.S. 647.97)	<u>116.45</u>	<u>0.408</u>
MAC (W.S. 391.34)	<u>558.63</u>	<u>1.955</u>
Fus. Sta. of .25 MAC	<u>1701.03</u>	<u>5.954</u>
W.P. of .25 MAC	<u>65.37</u>	<u>0.229</u>
B.L. of .25 MAC	<u>388.43</u>	<u>1.359</u>
<u>LEADING EDGE CURF</u>		
Planform area, ft ²	<u>46.13</u>	<u>0.00057</u>
Leading edge intersects Fus. M _L @ Sta., in.	<u>1182.86</u>	<u>4.110</u>
Leading edge intersects wing L.E. @ Sta., in.	<u>1425.7</u>	<u>4.970</u>

TABLE VII

MODEL COMPONENT: Elevon-E10 (Data for one of two sides)

GENERAL DESCRIPTION: Full span, constant chord elevon located on delta wing
W17.

Model Scale = 0.0035

DRAWING NUMBER: S-865-57, - 58

<u>DIMENSIONS:</u>	<u>FULL-SCALE</u>	<u>MODEL SCALE</u>
Area, ft ²	<u>193.10</u>	<u>0.00482</u>
Span (equivalent), in.	<u>128.83</u>	<u>1.501</u>
Inb'd equivalent chord, in. (W.S. 223.41)	<u>132.00</u>	<u>0.462</u>
Outb'd equivalent chord, in. (W.S. 652.25)	<u>132.00</u>	<u>0.462</u>
Ratio movable surface chord/ total surface chord		
At Inb'd equiv. chord	<u>0.116</u>	<u>0.116</u>
At Outb'd equiv. chord	<u>1.210</u>	<u>1.210</u>
Sweep Back Angles, degrees		
Leading Edge	<u>0.000</u>	<u>0.000</u>
Trailing Edge	<u>0.000</u>	<u>0.000</u>
Hingeline	<u>0.000</u>	<u>0.000</u>
Area Moment (Normal to hinge line), ft ³ (Product of area and mean chord)	<u>4314.87</u>	<u>0.00019</u>

TABLE VIII

MODEL COMPONENT: Vertical Stabilizer - V 17

GENERAL DESCRIPTION: Centerline vertical stabilizer with the 5° (half angle) wedge trailing edge. Used with delta wing orbiter body B5 (configuration 9992-134B).

The model scale factor is 0.0035.

DRAWING NUMBER: S-867-47, -50

DIMENSIONS:

FULL-SCALE

MODEL SCALE

TOTAL DATA

Area		
Planform, ft ²	663.63	0.00813
Theoretical Span, in.	380.421	
Span (equivalent), in.	372.61	1.304
Aspect Ratio	1.453	1.453
Rate of Taper	0.718	0.718
Taper Ratio	0.314	0.314
Dihedral Angle, degrees	-	-
Incidence Angle, degrees	-	-
Aerodynamic Twist, degrees	-	-
Toe-In Angle, degrees	0.0	0.0
Cant Angle, degrees	0.0	0.0
Sweep Back Angles, degrees		
Leading Edge	45.0	45.0
Trailing Edge	15.734	15.734
0.25 Element Line	39.367	39.367
Chords: Theoretical Tip, in.	117.053	
Root (W.P. 274.29 in)	390.29	1.366
Tip, (equivalent), (W.P. 646.90 in), in	122.65	0.429
MAC (W.P. 428.19 in), in	279.74	0.979
Fus. Sta. of .25 MAC, in	2032.98	7.115
W.P. of .25 MAC, in	428.19	1.499
B.L. of .25 MAC, in	0.0	0.0
Airfoil Section, Wedge shape with L.E.R. and flat T.E.		
L.E. Radius, in. (1.6% chord)	6.29	0.022

EXPOSED DATA

Area		
Span, (equivalent)		
Aspect Ratio		
Taper Ratio		
Chords		
Root		
Tip		
MAC		
Fus. Sta. of .25 M		
W.P. of .25 MAC		
B.L. of .25 MAC		

NOMENCLATURE

(General)

<u>SYMBOL</u>	<u>SADSAC SYMBOL</u>	<u>DEFINITION</u>
α	ALPHA	angle of attack, angle between the projection of the wind X_w -axis on the body X, Z-plane and the body X-axis; degrees
β	BETA	sideslip angle, angle between the wind X_w -axis and the projection of this axis on the body X-Z-plane; degrees
ψ	PSI	yaw angle, angle of rotation about the body Z-axis, positive when the positive X-axis is rotated toward the positive Y-axis; degrees
ϕ	PHI	roll angle, angle of rotation about the body X-axis, positive when the positive Y-axis is rotated toward the positive Z-axis; degrees
ρ		air density; K_g/m^3 , slugs/ft ³
a		speed of sound; m/sec, ft/sec
V		speed of vehicle relative to surrounding atmosphere; m/sec, ft/sec
q	Q(PSI) Q(PSF)	dynamic pressure; $1/2\rho V^2$, psi, psf
M	MACH	Mach number; V/a
RN/L	RN/L	Reynolds number per unit length; million/ft
p		static pressure; psi
P		total pressure; psi
C_p	CP	pressure coefficient; $(p-p_\infty)/q$

NOMENCLATURE (Continued)

Reference & C. G. Definitions

<u>SYMBOL</u>	<u>SADSAC SYMBOL</u>	<u>DEFINITION</u>
S		wing area; m^2 , ft^2
S	SREF	reference area; m^2 , ft^2
\bar{c}		wing mean aerodynamic chord or reference chord; m, ft, in. (see l_{ref} or LREF)
l_{ref}	LREF	reference length; m, ft, in.; (see \bar{c})
b_{ref}	BREF	wing span or reference span; m, ft, in
A_b		base area; m^2 , ft^2 , in^2
c. g.		center of gravity
MRP	MRP	abbreviation for moment reference point
	XMRP	abbreviation for moment reference point on X-axis
	YMRP	abbreviation for moment reference point on Y-axis
	ZMRP	abbreviation for moment reference point on Z-axis

OMENCLATURE (Continued)

Axis System General

<u>SYMBOL</u>	<u>DEFINITION</u>
F	Force; F, lbs
M	Moment; M, in-lb
<u>Subscript</u>	<u>Definition</u>
N	normal force
A	axial force
L	Lift force
D	drag force
Y	Force or moment about the Y axis
Z	Moment about the Z axis
X	Moment about the X axis
s	stability axis system
w	wind axis system
ref	reference conditions
∞	free stream conditions
t	total conditions
b	base

NOMENCLATURE (Continued)

Stability Axis System

<u>SYMBOL</u>	<u>SALDASAC SYMBOL</u>	<u>DEFINITION</u>
C_L	CL	lift force coefficient; F_L/qS
C_D	CD	drag force coefficient; F_D/qS
C_{D_b}	CDB	base drag coefficient
C_{D_f}	CDF	forebody drag coefficient; $C_D - C_{D_b}$
C_m	CLM	pitching moment coefficient; $M_{y,s}/qS l_{ref}$
C_y	CY	side force coefficient; F_y/qS
C_n	CLN	yawing moment coefficient; $M_{z,s}/qS b_{ref}$
C_l	CSL	rolling moment coefficient; $M_{x,s}/qS b_{ref}$
L/D	L/D	lift-to-drag ratio; C_L/C_D
L/D	L/DF	lift to forebody drag ratio; C_L/C_{D_f}

NOMENCLATURE (Continued)

Surface Definitions

<u>SYMBOL</u>	<u>SADSAC SYMBOL</u>	<u>DEFINITION</u>
i_t	HORIZT	horizontal tail incidence; positive when trailing edge down; degrees
δ		symmetrical surface deflection angle; degrees; positive deflections are:
	AILRON	aileron - total aileron deflection; (left aileron - right aileron)/2
	CANARD	canard - trailing edge down
	ELEVON	elevon - trailing edge down
	ELVATR	elevator - trailing edge down
	FLAP	flap - trailing edge down
	RUDDER	rudder - trailing edge to the left
	SPOILER	spoiler - trailing edge down
	TAB	tab - trailing edge down with respect to control surface
δ		antisymmetrical surface deflection angle, degrees; positive trailing edge down:
	AIL-L	left aileron - trailing edge down
	AIL-R	right aileron - trailing edge down
	ELVN-L	left elevon - trailing edge down
	ELVN-R	right elevon - trailing edge down
	SPLR-L	left spoiler - trailing edge down
	SPLR-R	right spoiler - trailing edge down

<u>SURFACE SUBSCRIPTS</u>	<u>DEFINITION</u>
a	aileron
b	base
c	canard
e	elevator or elevon
f	flap
r	rudder or ruddervator
s	spoiler
t	tail

TABULATED DATA LISTING

A tabulated data listing, consisting of all aero data sets, both original and those created in arriving at the plotted material to be presented subsequently, is available as an addendum to this report. The tabular listing is made up in two sections:

- (a) a brief summary list of all data sets containing the identifier, the descriptor, and the resident dependent variables.
- (b) a full list of all data sets containing all resident or selected aerodynamic coefficients of the data sets as well as the above mentioned information.

The listing is currently sent on limited distribution to the following organizations:

NASA AMES	Mr. V. Stevens
NASA MSC	Mr. Ray Nelson
NASA MSFC	Mr. Jim Weaver

If copies of this listing are desired, please contact the above or the cognizant SADSAC personnel who, for this data, is:

Mr. John Hord
Department 2780
Chrysler Corporation Space Division
New Orleans, La. 70129

(504) 255-2304

PLOTTED DATA

MSFC TWT 477 NR DELTA WING ORBITER DATA

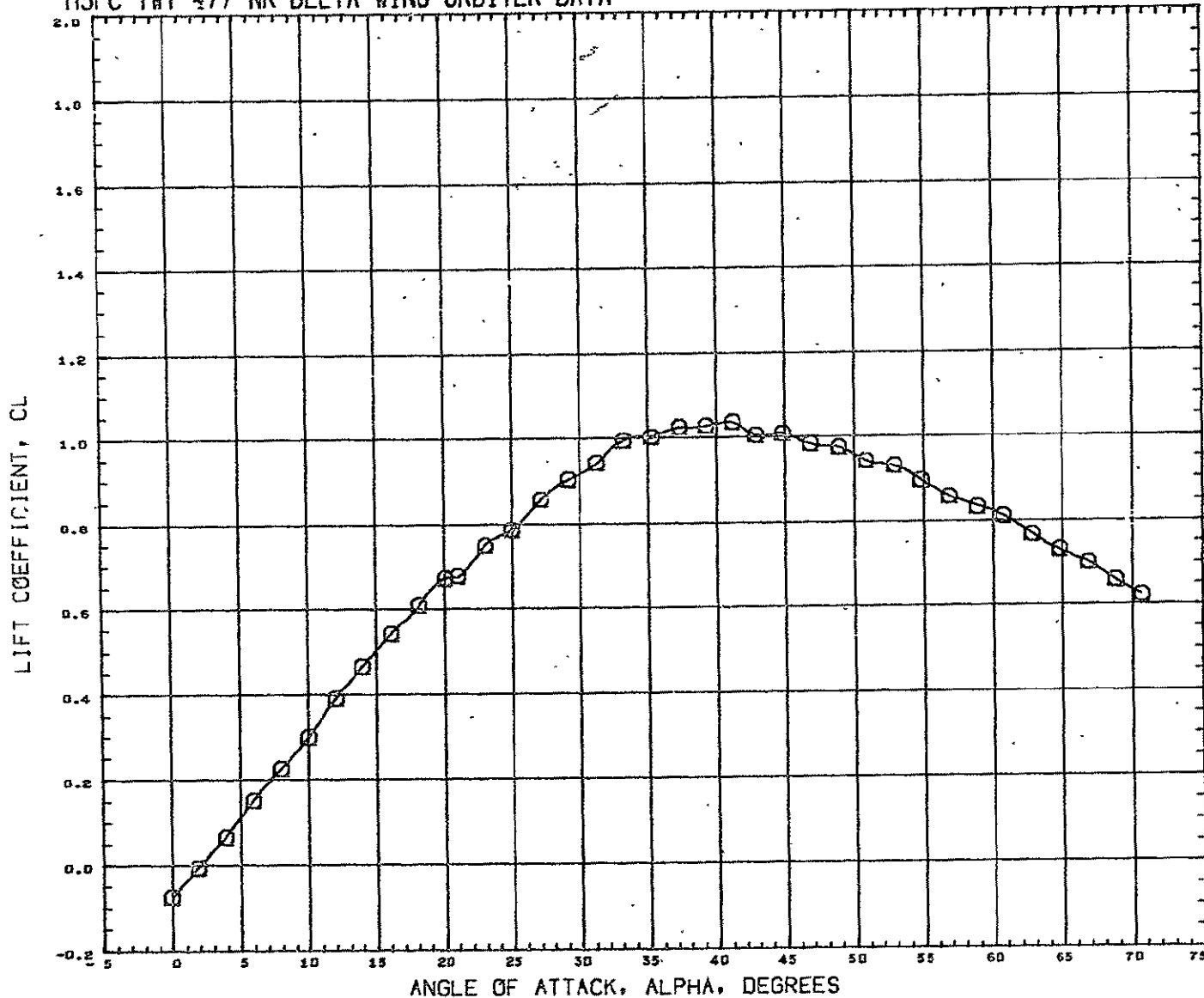

SYMBOL Q MACH 0.400 BETA 0.000 ELVAIR 0.000

REFERENCE INFORMATION
 SREF 0.0745 SQ FT
 LREF 2.8742 INCHES
 BREF 4.9798 INCHES
 XHRP 4.9787 INCHES
 YHRP 0.0000 INCHES
 ZHRP 0.4550 INCHES
 SCALE 0.0035 SCALE

DATA HIST. CODE #EV#G

MSFC TWT 477 NR DELTA WING ORBITER DATA

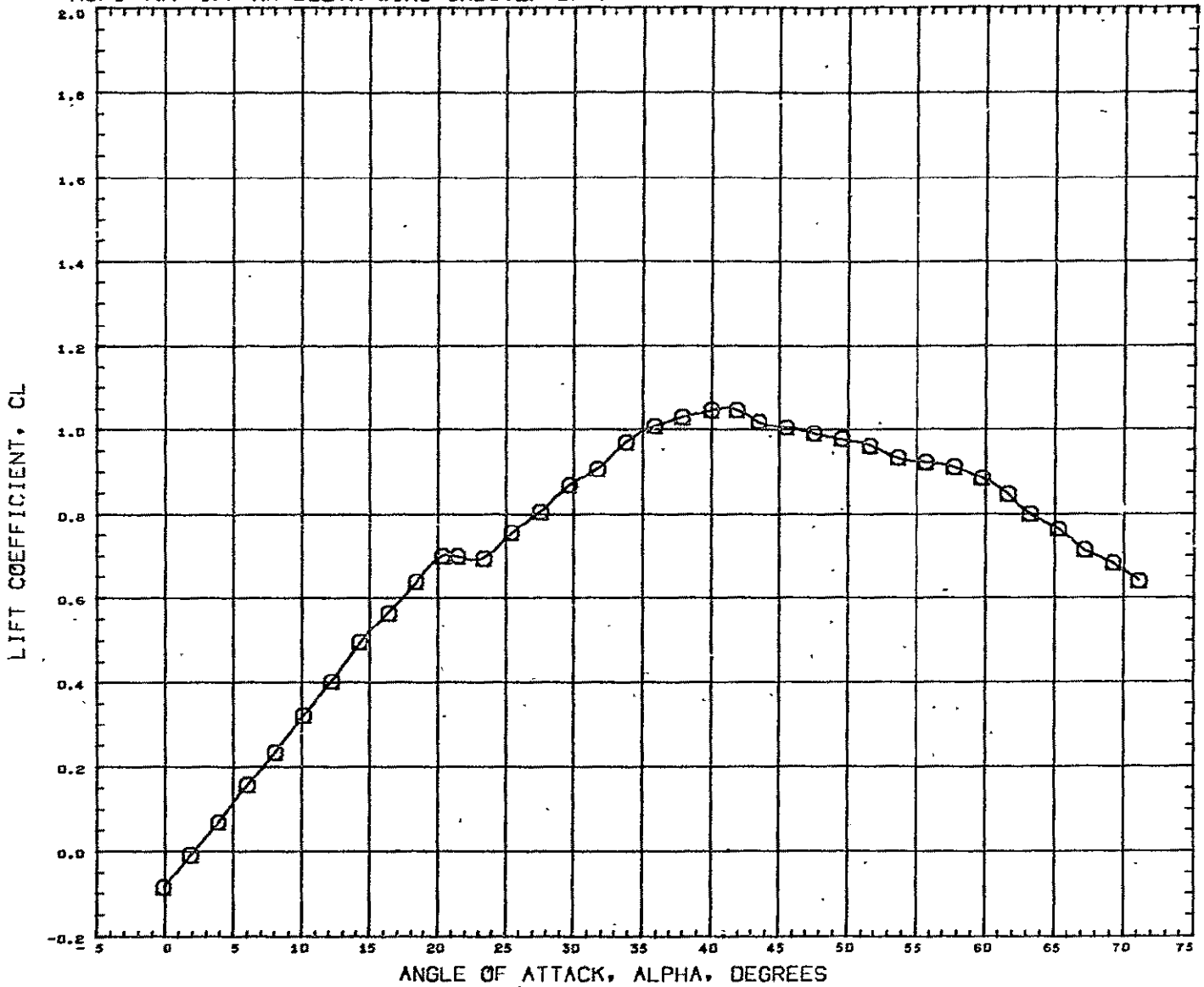

SYMBOL MACH PARAMETRIC VALUES
 ○ 0.598 BETA 0.000 ELVATR 0.000

REFERENCE INFORMATION
 SREF 0.0745 SQ FT
 LREF 2.8742 INCHES
 BREF 4.9798 INCHES
 XHRP 4.9787 INCHES
 YHRP 0.0000 INCHES
 ZHRP 0.4550 INCHES
 SCALE 0.0035 SCALE

DATA HIST. CODE #EV#G

MSFC TWT 477 NR DELTA WING ORBITER DATA

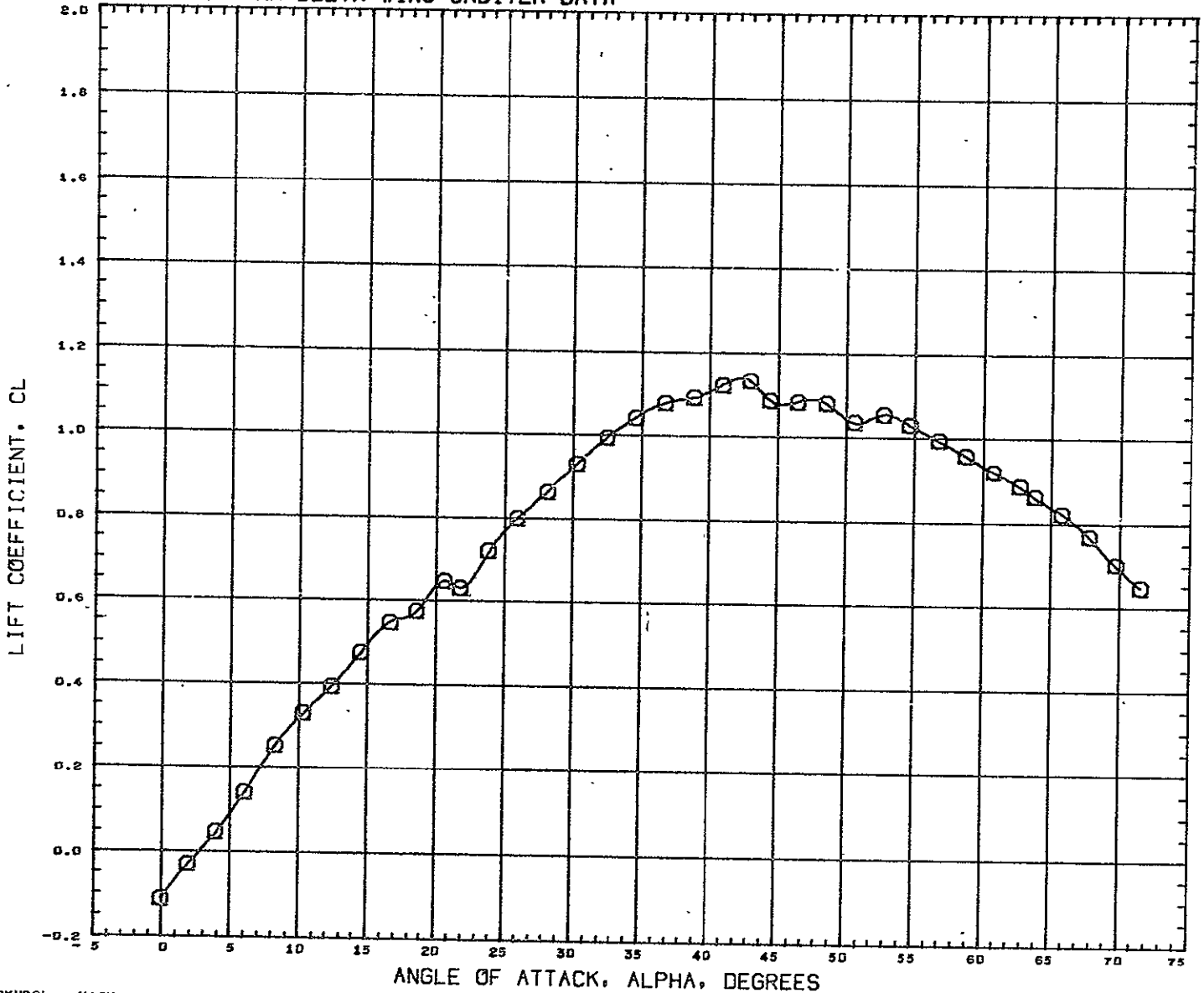

SYMBOL MACH PARAMETRIC VALUES
 O 0.898 BETA 0.000 ELVATR 0.000

REFERENCE INFORMATION
 SREF 0.0745 SQ FT
 LREF 2.8742 INCHES
 BREF 4.9798 INCHES
 XHRP 4.9787 INCHES
 YHRP 0.0000 INCHES
 ZHRP 0.4550 INCHES
 SCALE 0.0035 SCALE

DATA HIST. CODE #EV*G

MSFC TWT 477 NR DELTA WING ORBITER DATA

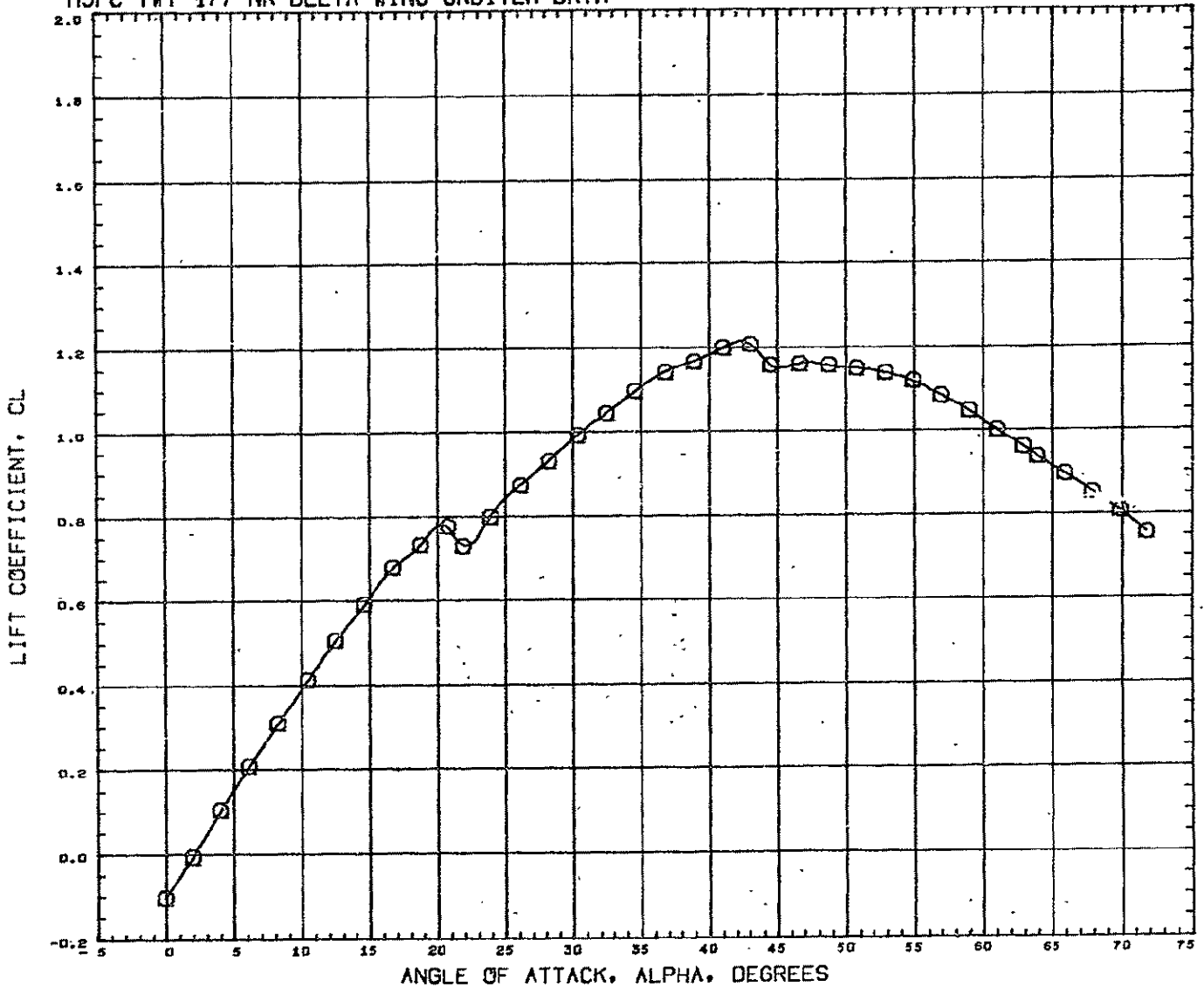

SYMBOL MACH PARAMETRIC VALUES
 O 0.999 BETA 0.000 ELVATR 0.000

REFERENCE INFORMATION
 SREF 0.0745 SQ FT
 LREF 2.8742 INCHES
 BREF 4.9799 INCHES
 XMRP 4.9787 INCHES
 YMRP 0.0000 INCHES
 ZMRP 0.4550 INCHES
 SCALE 0.0035 SCALE

DATA HIST. CODE #EV#6

MSFC TWT 477 NR DELTA WING ORBITER DATA

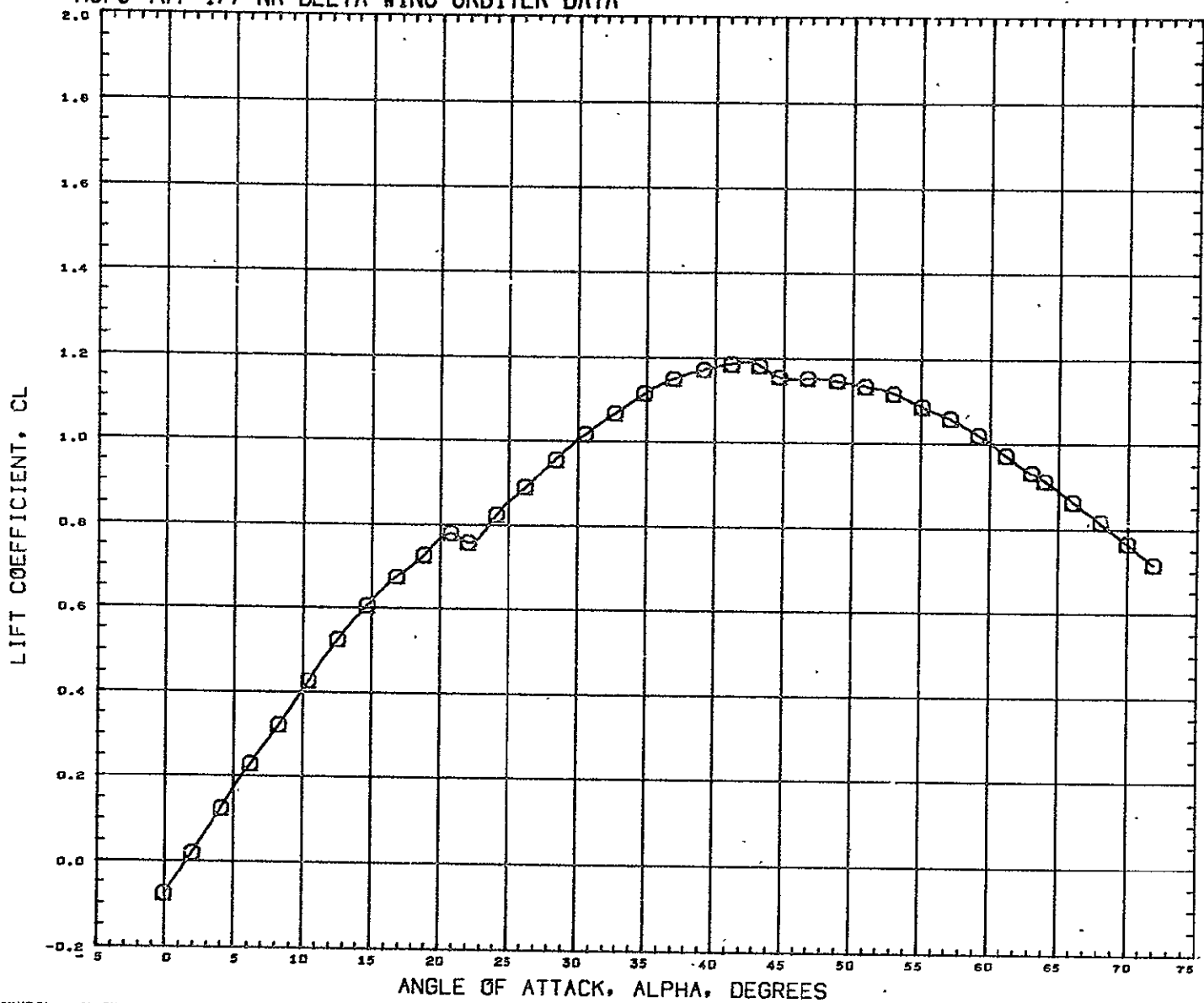

SYMBOL MACH PARAMETRIC VALUES
 □ 1.103 BETA 0.000 ELVATR 0.000

REFERENCE INFORMATION

SREF	0.0745	SQ FT
LREF	2.8742	INCHES
BREF	4.9798	INCHES
XMRP	4.9787	INCHES
YMRP	0.0000	INCHES
ZMRP	0.4550	INCHES
SCALE	0.0035	SCALE

DATA HIST. CODE #EV*G

MSFC TWT 477 NR DELTA WING ORBITER DATA

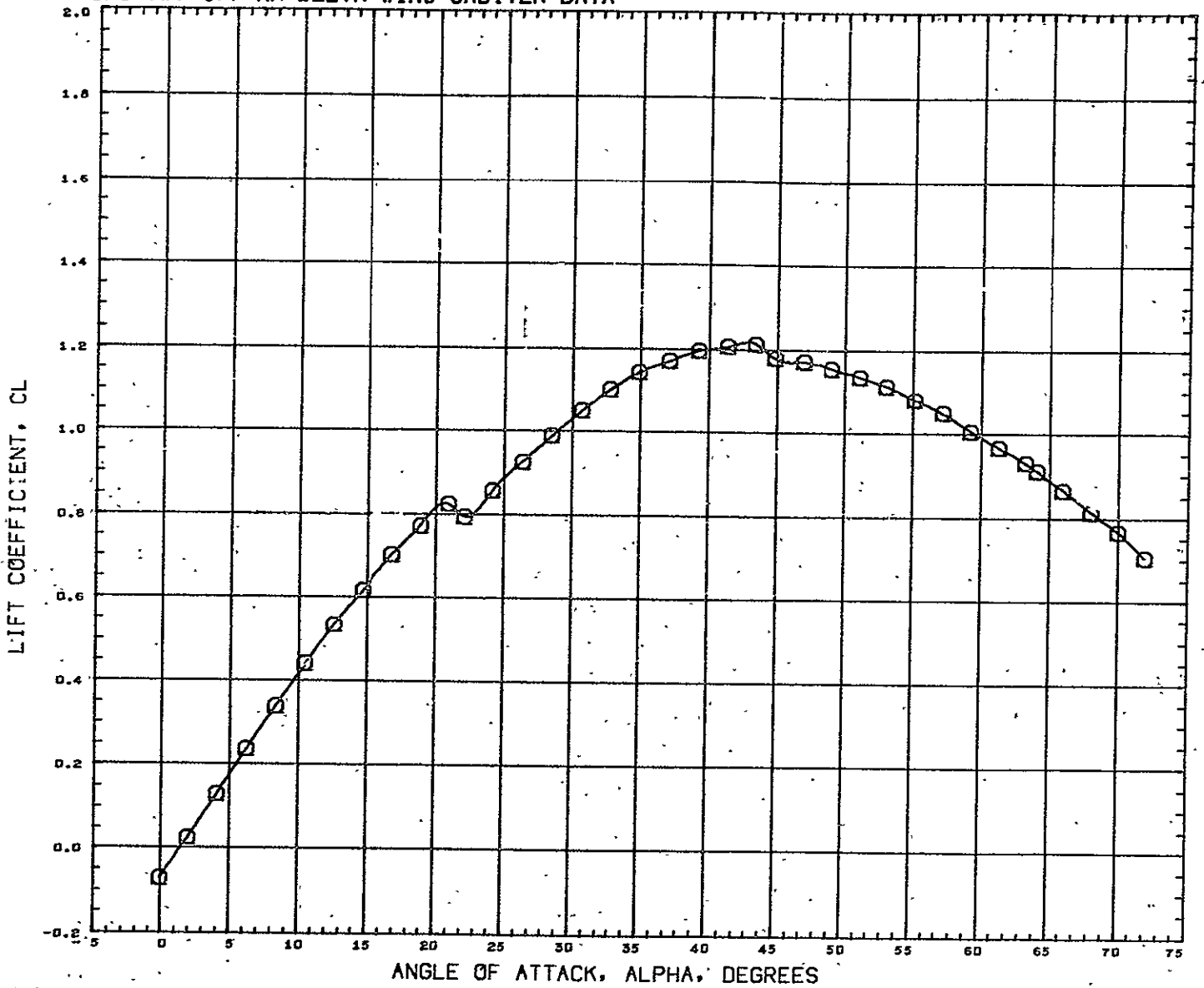

SYMBOL MACH PARAMETRIC VALUES
 O 1.201 BETA 0.000 ELVATR 0.000

REFERENCE INFORMATION
 SREF 0.0745 SQ FT-
 LREF 2.8742 INCHES
 BREF 4.9798 INCHES
 XHRP 4.9787 INCHES
 YHRP 0.0000 INCHES
 ZHRP 0.4550 INCHES
 SCALE 0.0035 SCALE

DATA HIST. CODE *EV+G

MSFC TWT 477 NR DELTA WING ORBITER DATA

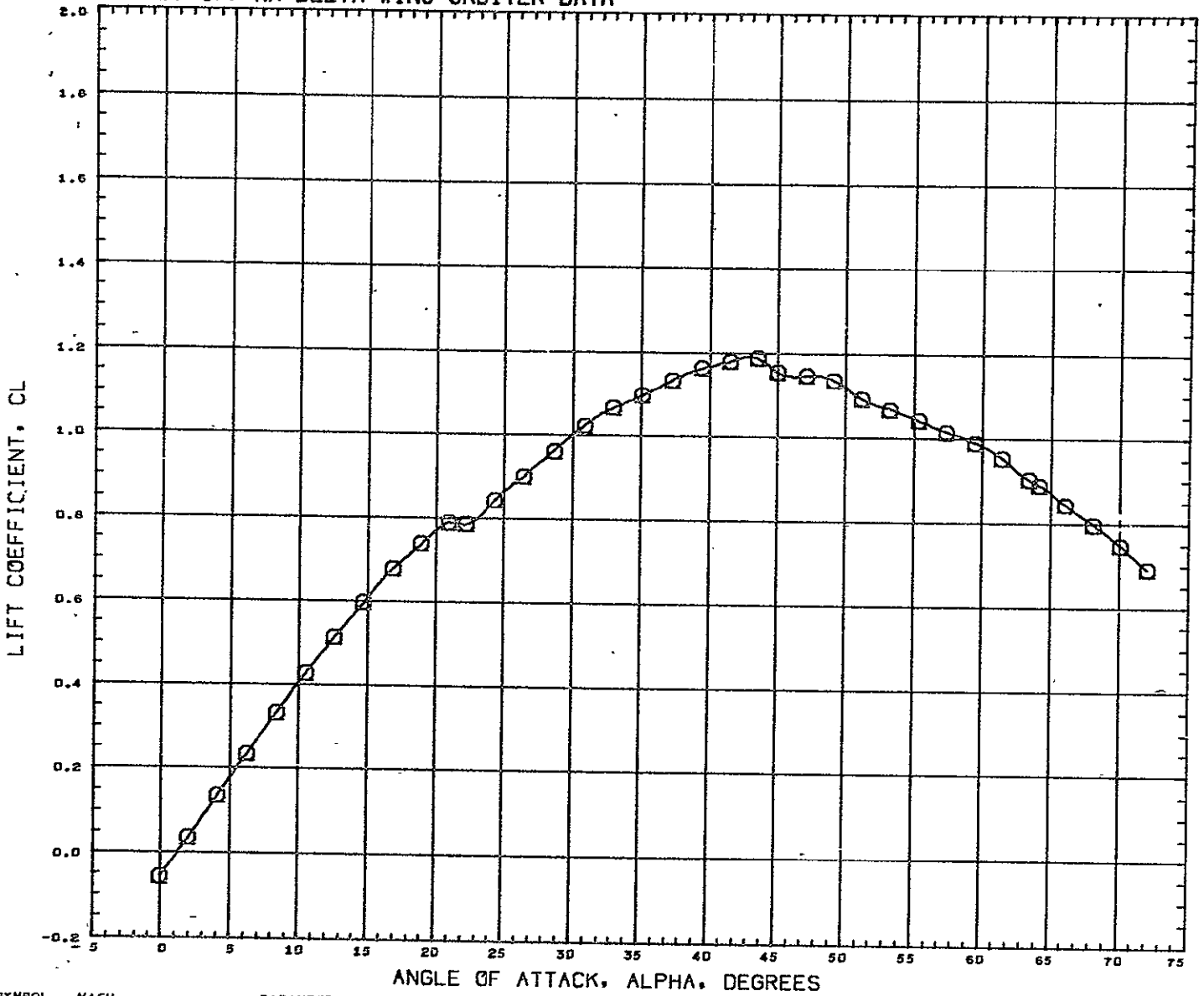

SYMBOL MACH PARAMETRIC VALUES
 O 1.300 BETA 0.000 ELVATR 0.000

REFERENCE INFORMATION
 SREF 0.0745 SQ FT
 LREF 2.8742 INCHES
 BREF 4.9798 INCHES
 XMRP 4.9767 INCHES
 YMRP 0.0000 INCHES
 ZMRP 0.4550 INCHES
 SCALE 0.0035 SCALE

DATA HIST. CODE *EV46

MSFC TWT 477 NR DELTA WING ORBITER DATA.

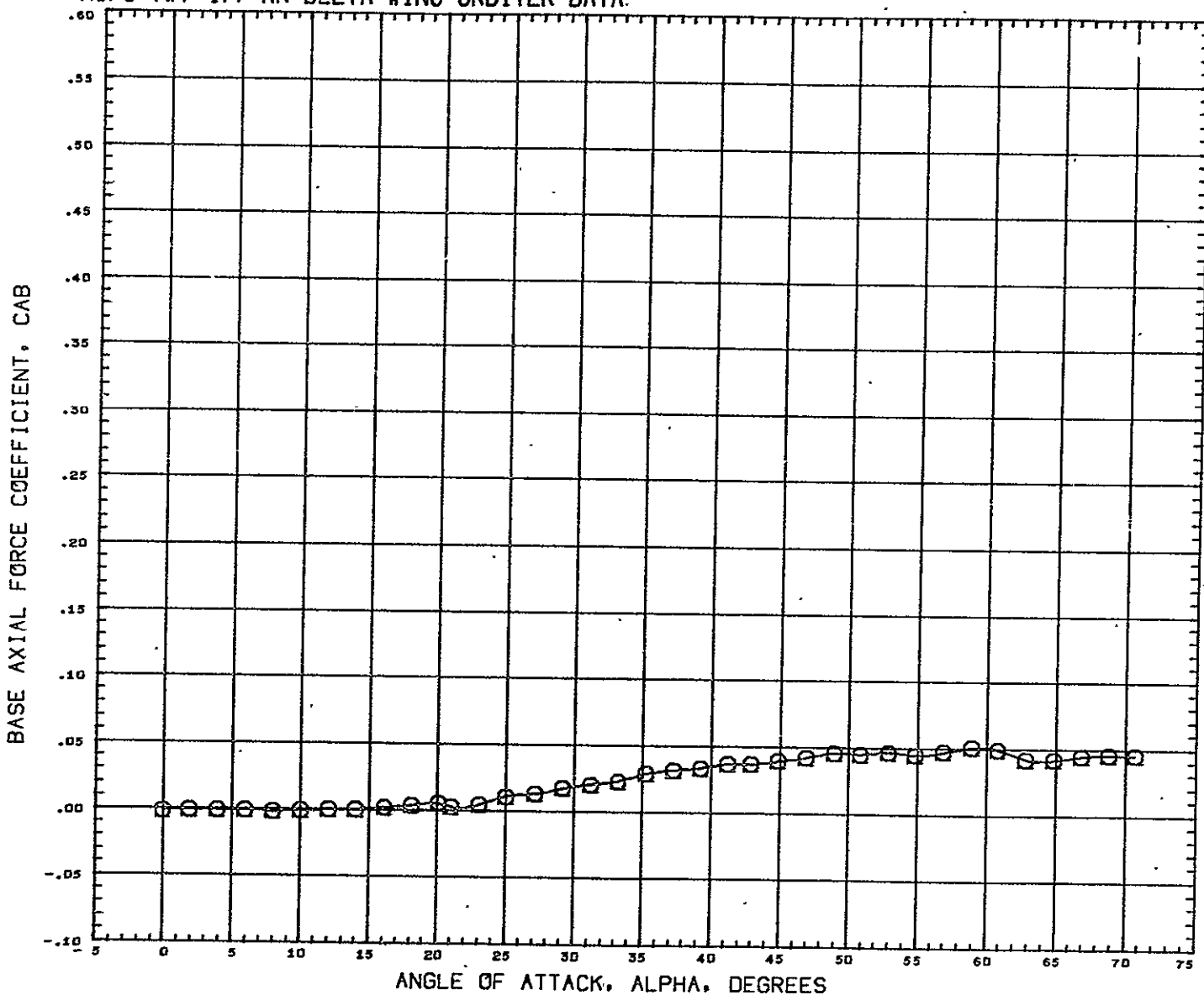

SYMBOL \bigcirc MACH 0.400 BETA 0.000 ELVATR 0.000

PARAMETRIC VALUES

REFERENCE INFORMATION

SREF	0.0745	SQ FT
LREF	2.8742	INCHES
BREF	4.9790	INCHES
XHRP	4.9767	INCHES
YHRP	0.0000	INCHES
ZHRP	0.4550	INCHES
SCALE	0.0035	SCALE

DATA HIST. CODE *EV#6

MSFC TWT 477 NR DELTA WING ORBITER DATA

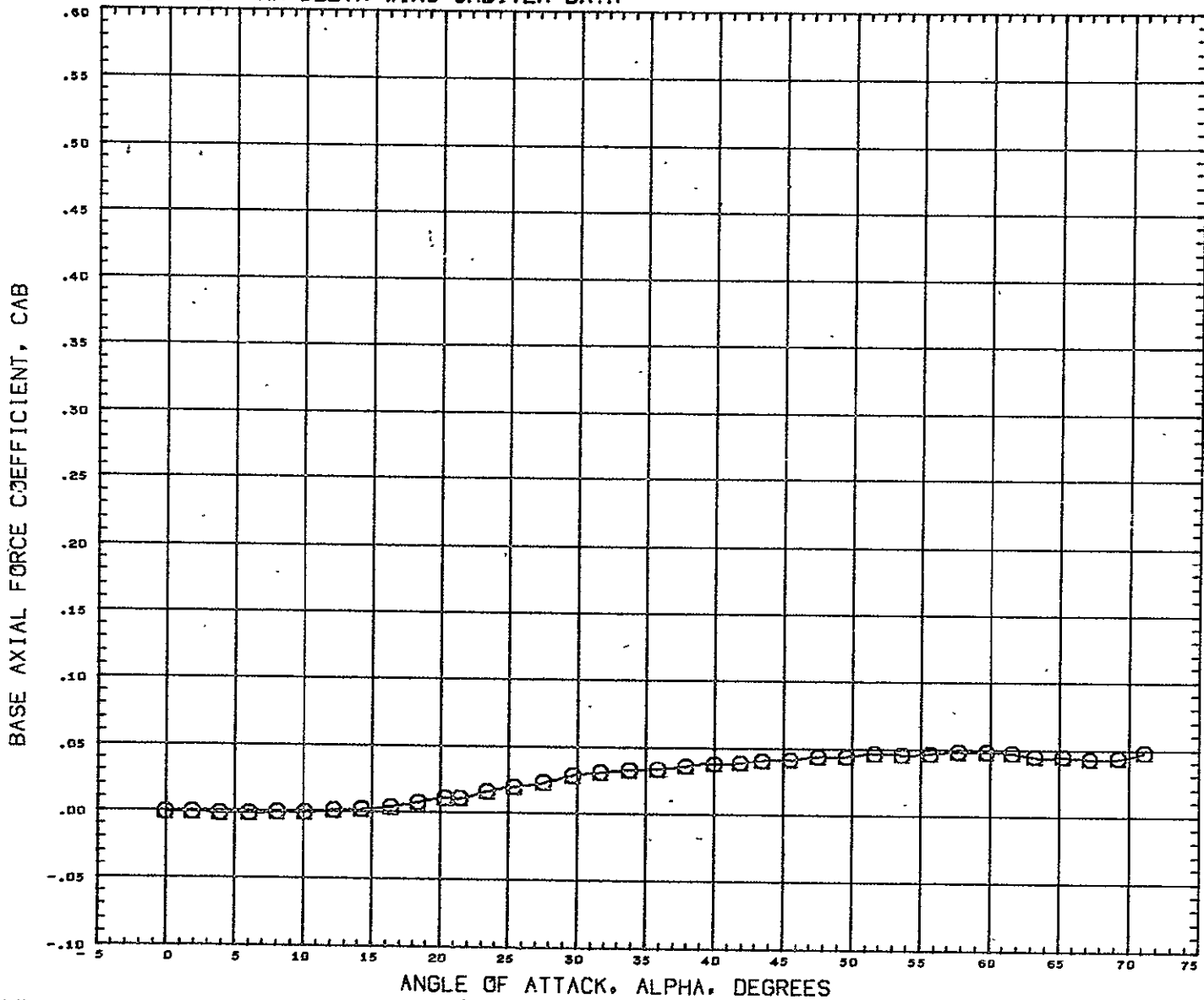

SYMBOL \circ MACH 0.598 BETA 0.000 ELVATR 0.000
 PARAMETRIC VALUES

REFERENCE INFORMATION

SREF	0.0745	SQ FT
LREF	2.8742	INCHES
BREF	4.9798	INCHES
XMRP	4.9787	INCHES
YMRP	0.0000	INCHES
ZMRP	0.4550	INCHES
SCALE	0.0035	SCALE

DATA HIST. CODE #EV*6

MSFC TWT 477 NR DELTA WING ORBITER DATA

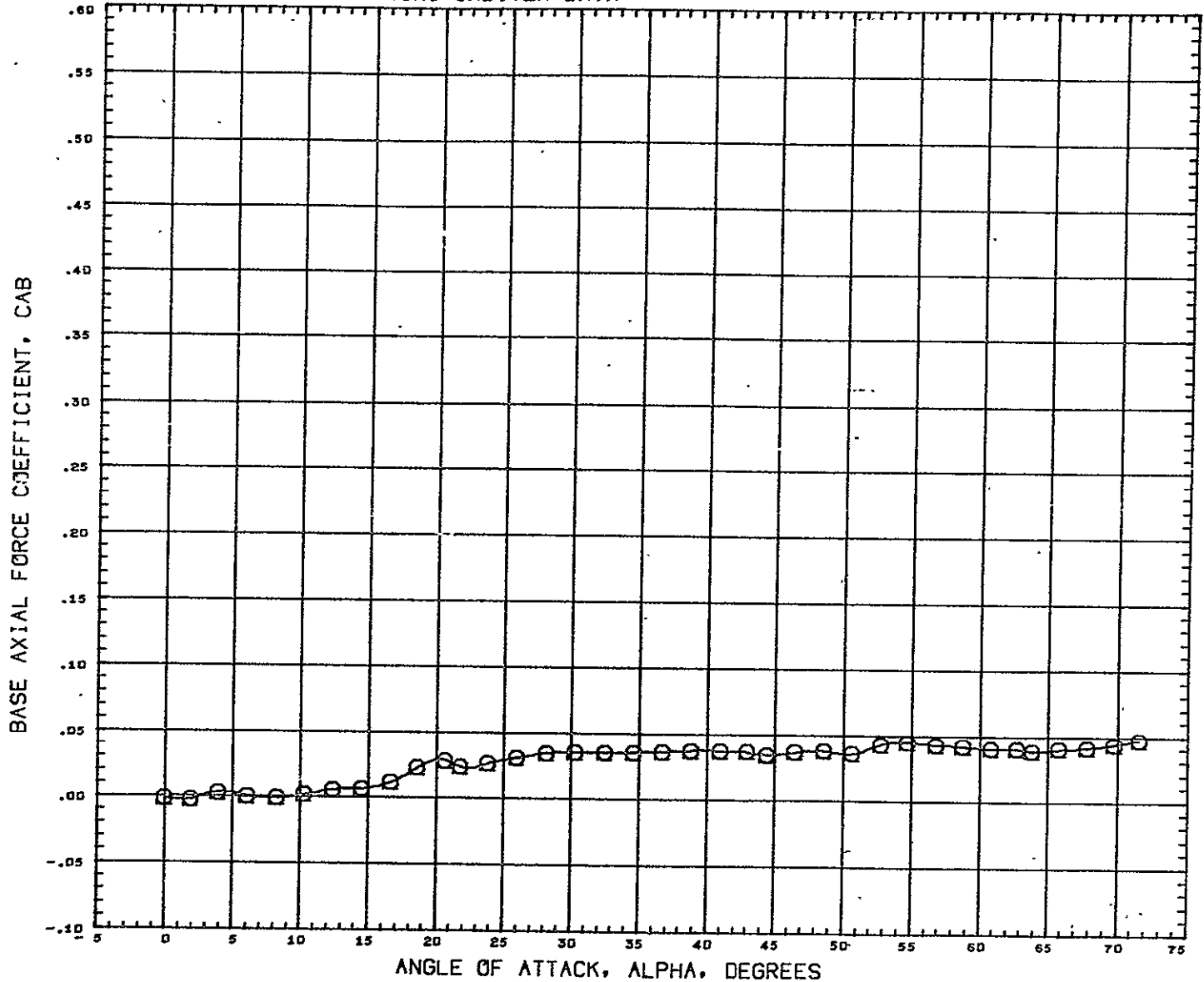

SYMBOL MACH PARAMETRIC VALUES
 O 0.898 BETA 0.000 ELVATR 0.000

REFERENCE INFORMATION
 SREF 0.0745 SQ FT
 LREF 2.8742 INCHES
 BREF 4.9798 INCHES
 XMRP 4.9787 INCHES
 YMRP 0.0000 INCHES
 ZMRP 0.4550 INCHES
 SCALE 0.0035 SCALE

DATA HIST. CODE #EV7G

MSFC TWT 477 NR DELTA WING ORBITER DATA

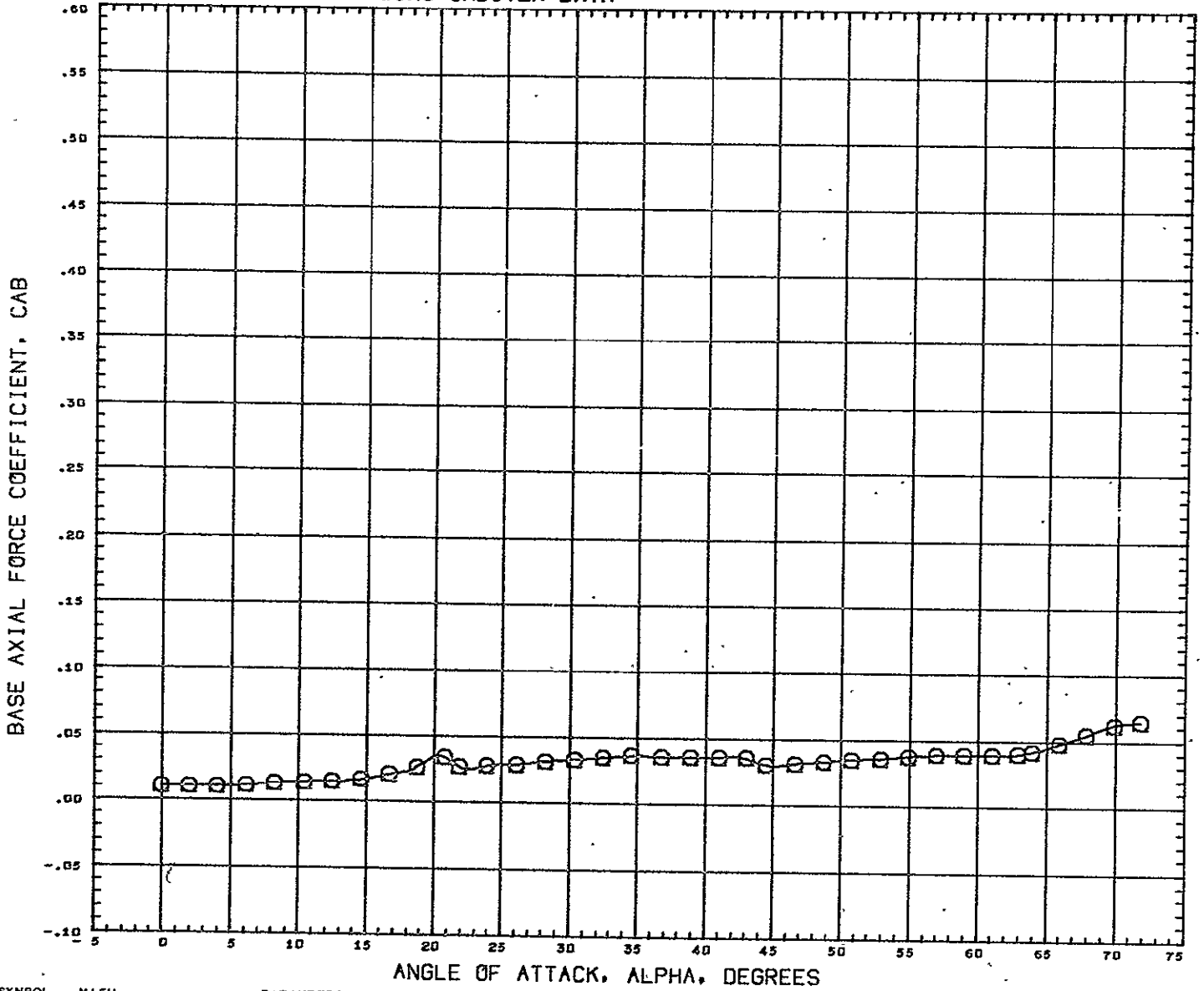

SYMBOL MACH PARANETRIC VALUES
 O 0.999 BETA 0.000 ELVATR 0.000

REFERENCE INFORMATION
 SREF 0.0745 SQ FT
 LREF 2.8742 INCHES
 BREF 4.9796 INCHES
 XMRP 4.9787 INCHES
 YMRP 0.0000 INCHES
 ZMRP 0.4550 INCHES
 SCALE 0.0035 SCALE

DATA HIST. CODE #EV#6

MSFC TWT 477 NR DELTA WING ORBITER DATA

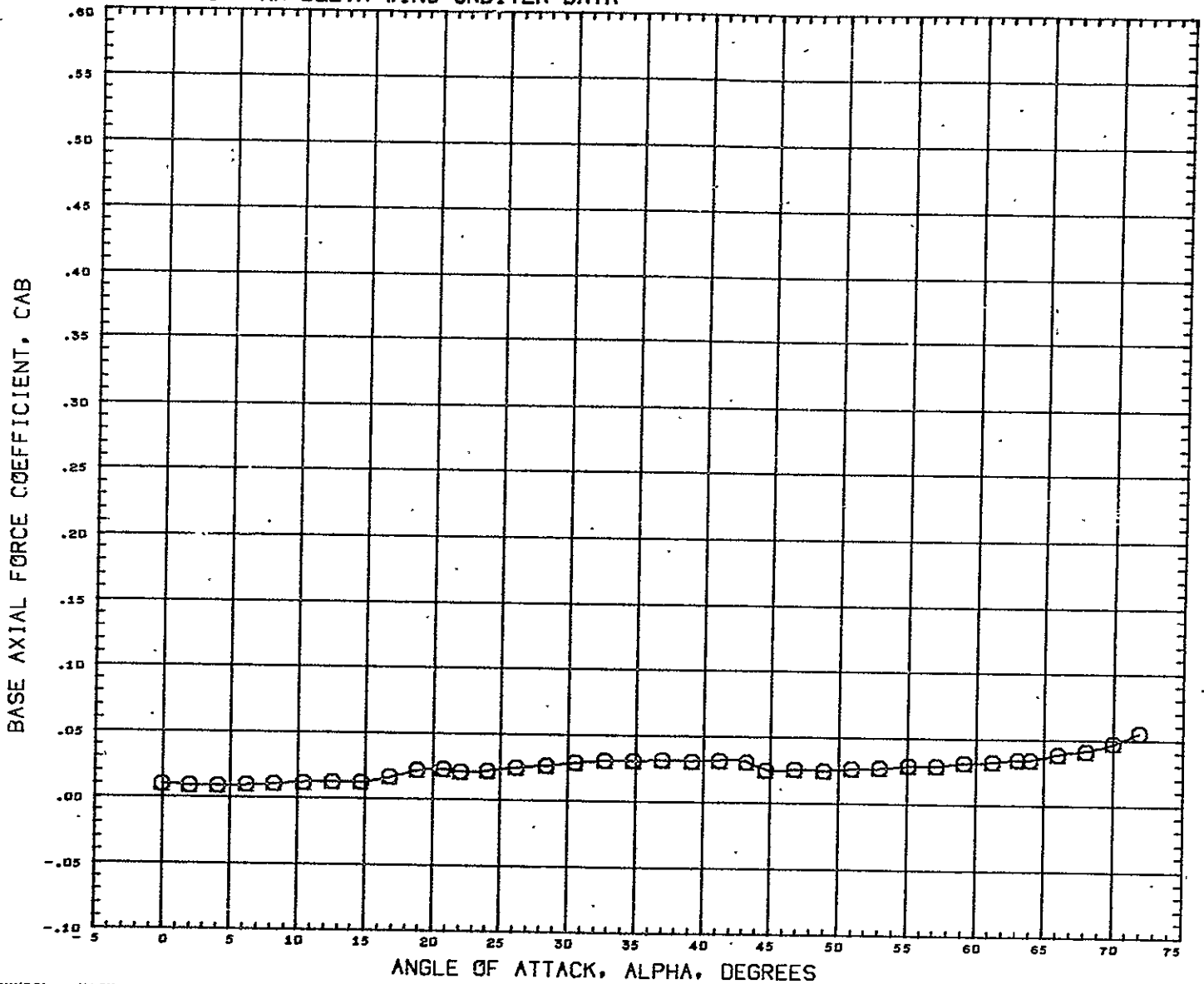

SYMBOL MACH PARAMETRIC VALUES
 O 1.103 BETA 0.000 ELVATR 0.000

REFERENCE INFORMATION
 SREF 0.0745 SQ FT
 LREF 2.8742 INCHES
 BREF 4.9798 INCHES
 XHRP 4.9787 INCHES
 YHRP 0.0000 INCHES
 ZHRP 0.4550 INCHES
 SCALE 0.0035 SCALE

DATA HIST. CODE *EV*G

MSFC TWT 477 NR DELTA WING ORBITER DATA

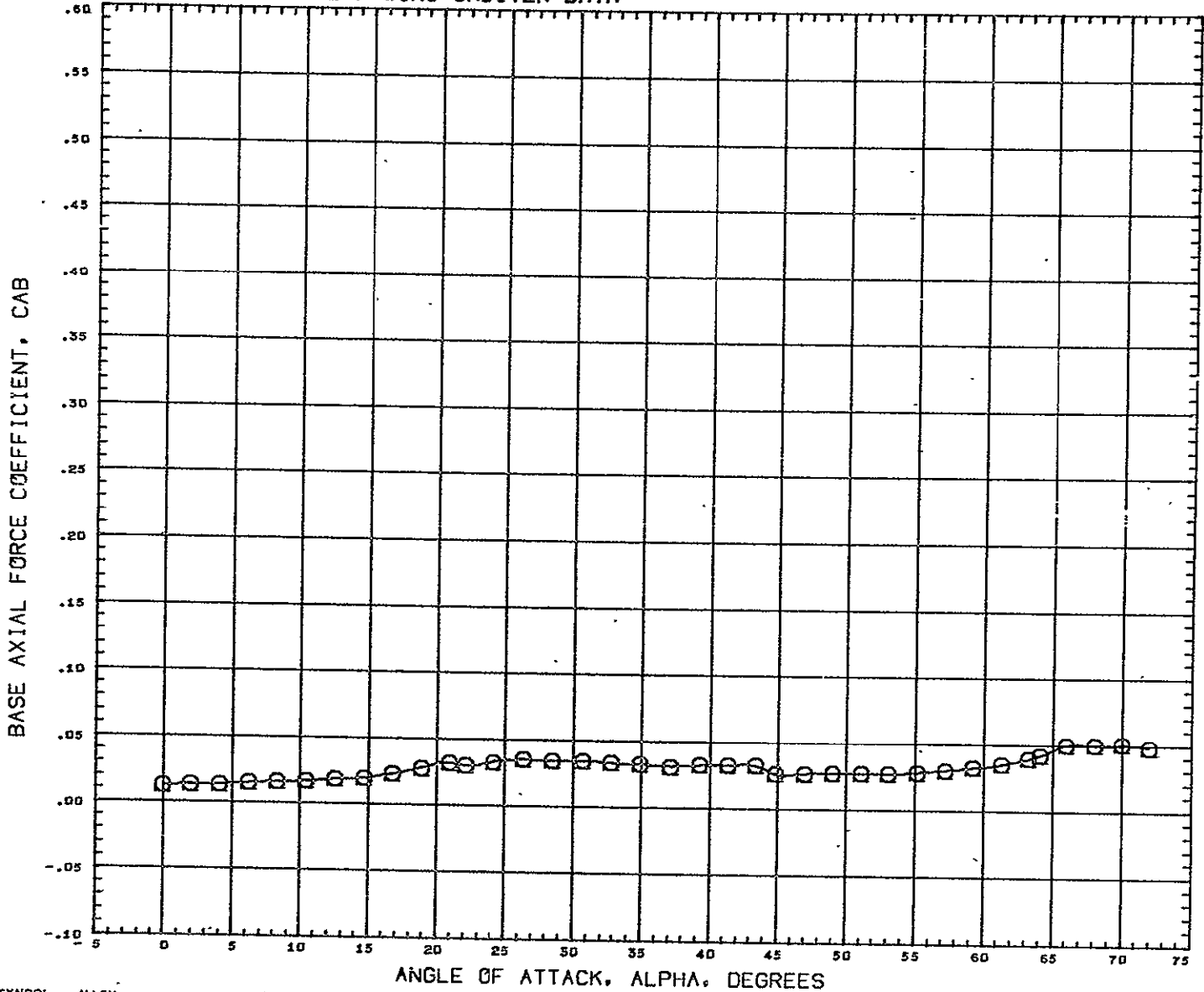

SYMBOL \square MACH 1.203 BETA 0.000 ELVATR 0.000

REFERENCE INFORMATION
 SREF 0.0745 SQ FT
 LREF 2.8742 INCHES
 BREF 4.9798 INCHES
 XMRP 4.9787 INCHES
 YMRP 0.0000 INCHES
 ZMRP 0.4550 INCHES
 SCALE 0.0035 SCALE

DATA HIST. CODE #EV*G

MSFC TWT 477 NR DELTA WING ORBITER DATA

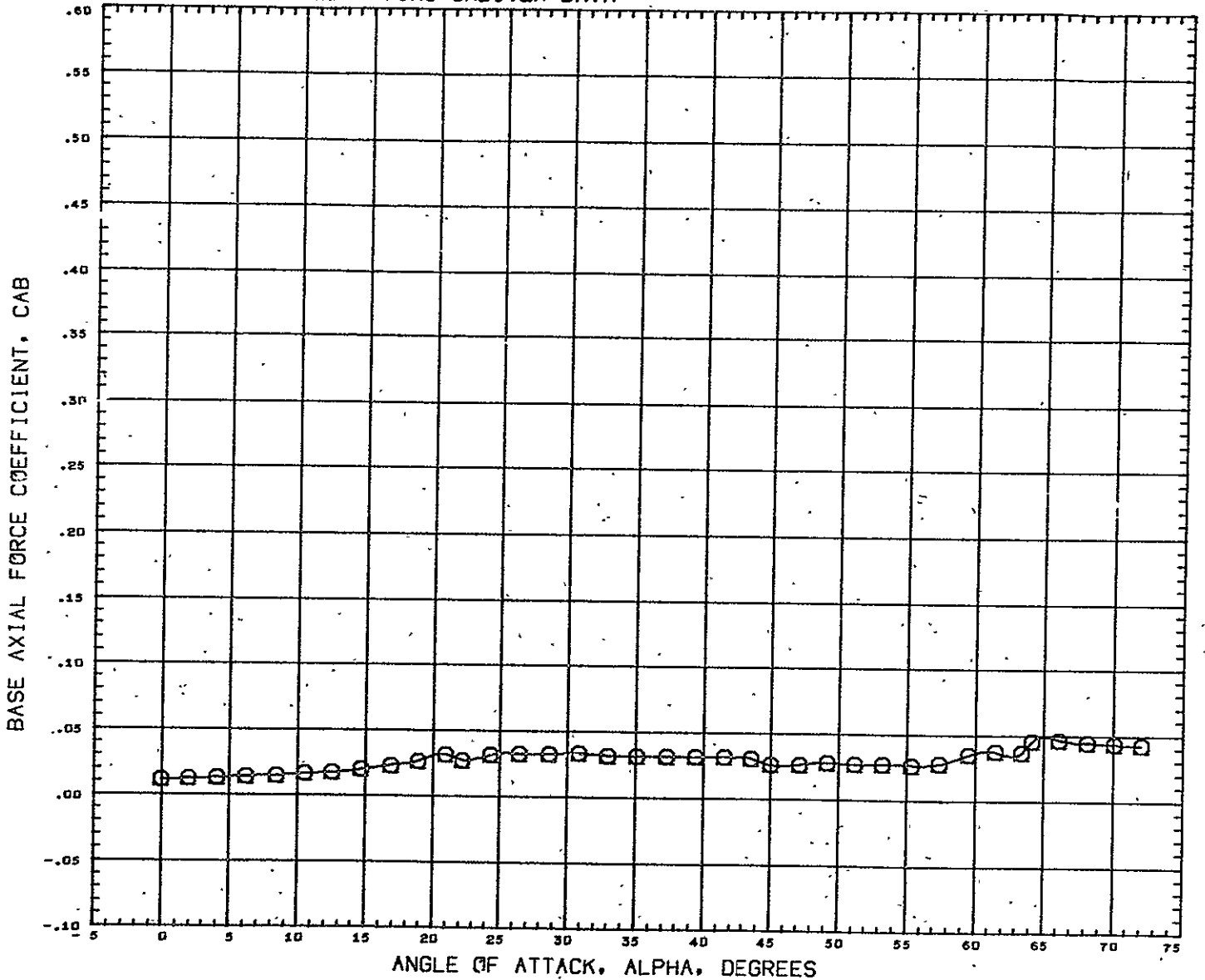

SYMBOL MACH BETA PARAMETRIC VALUES
 ○ 1.300 0.000 ELVATR 0.000

REFERENCE INFORMATION
 SREF 0.0745 SQ FT
 LREF 2.8742 INCHES
 BREF 4.9798 INCHES
 XHRP 4.9787 INCHES
 YHRP 0.0000 INCHES
 ZHRP 0.4550 INCHES
 SCALE 0.0035 .SCALE

DATA HIST. CODE *EV*G

MSFC TWT 477 NR DELTA WING ORBITER DATA

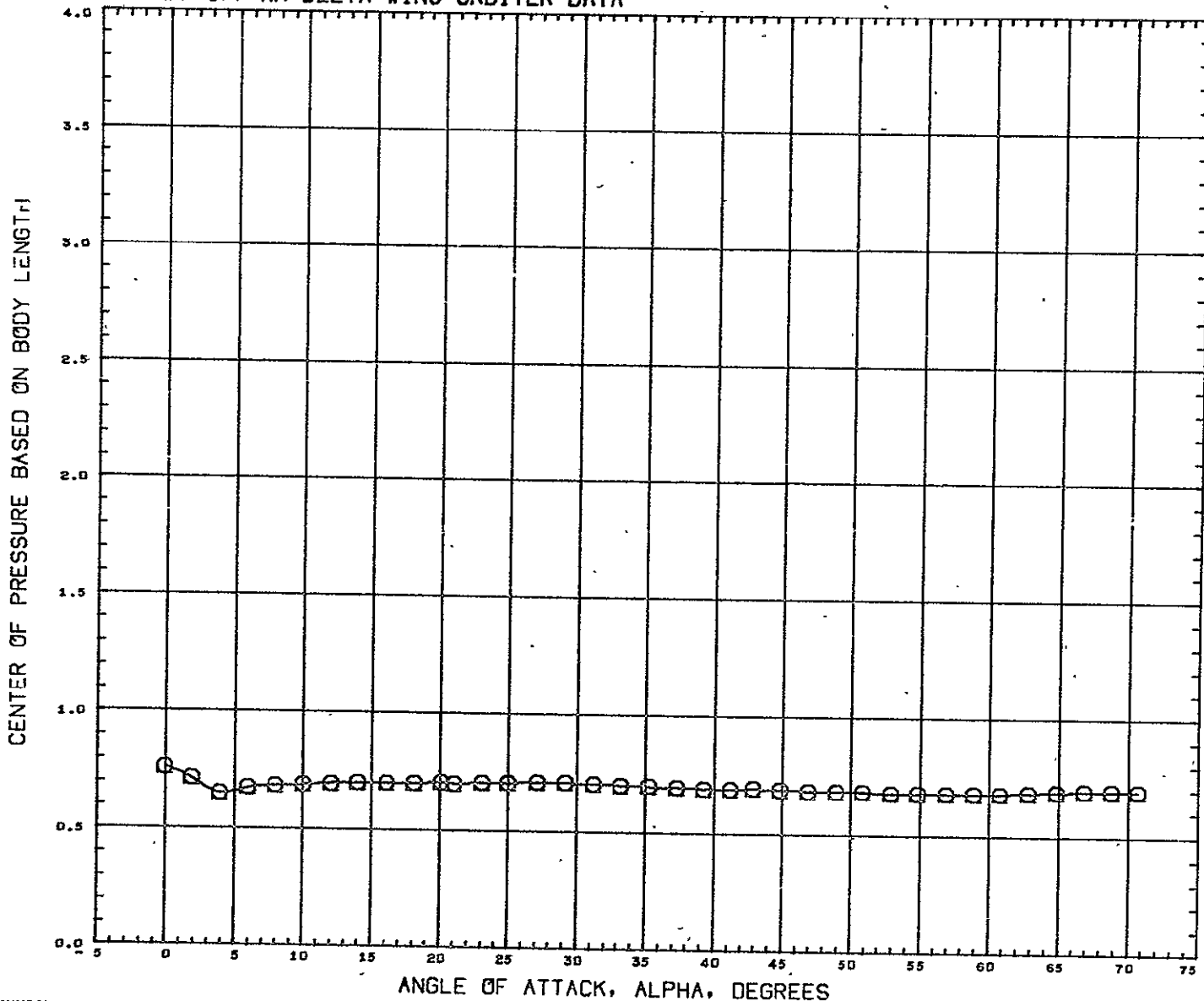

SYMBOL MACH PARAMETRIC VALUES
 O 0.400 BETA 0.000 ELVATR 0.000

REFERENCE INFORMATION
 SREF 0.0745 SQ FT
 LREF 2.8742 INCHES
 BREF 4.9798 INCHES
 XMRP 4.9787 INCHES
 YMRP 0.0000 INCHES
 ZMRP 0.4550 INCHES
 SCALE 0.0035 SCALE

DATA HIST. CODE #EV*6

MSFC TWT 477 NR DELTA WING ORBITER DATA

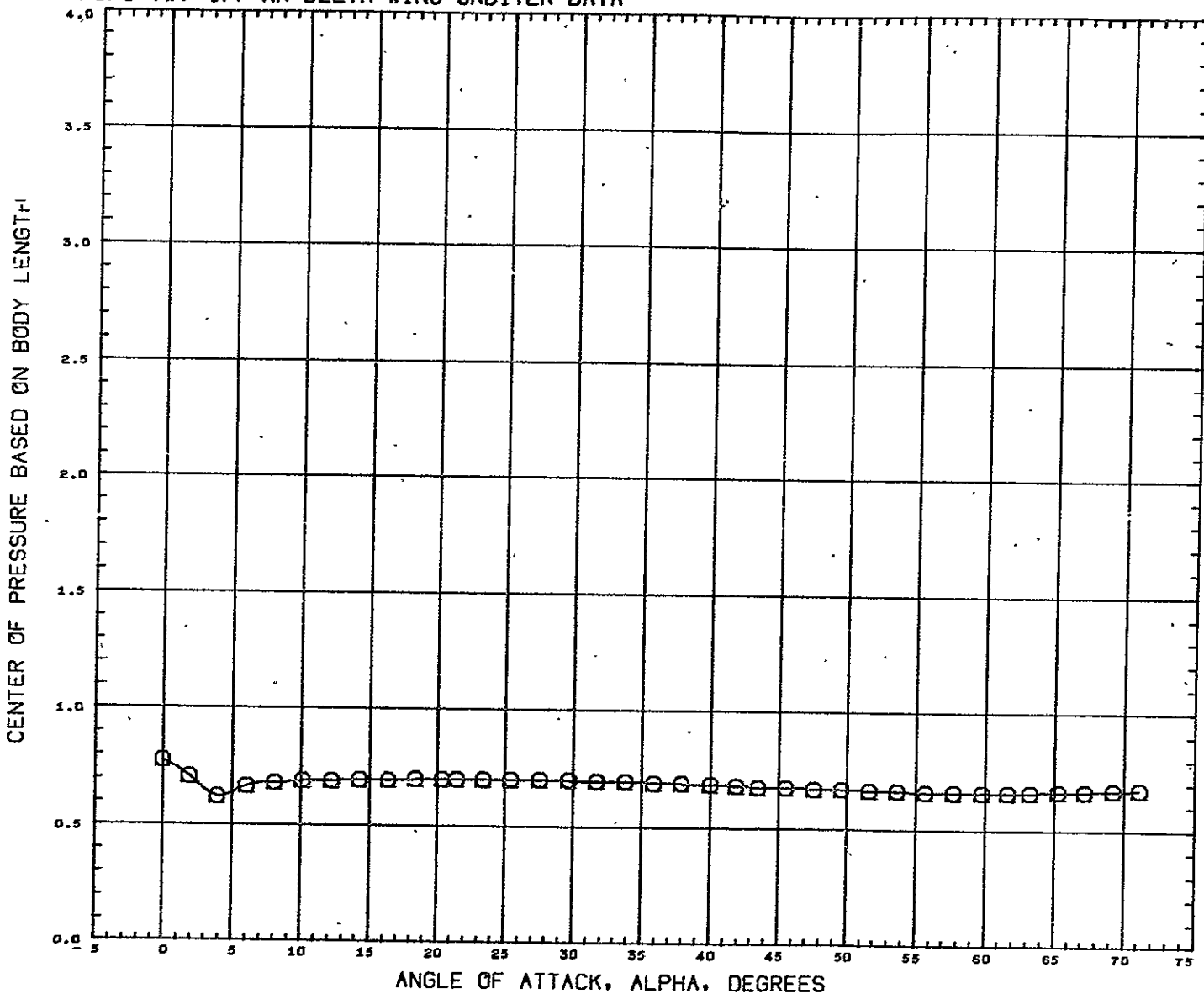

SYMBOL \bigcirc MAC. 0.598 BETA 0.000 ELVATR 0.000

REFERENCE INFORMATION
 SREF 0.0745 SQ FT
 LREF 2.8742 INCHES
 BREF 4.9796 INCHES
 XHRP 4.9787 INCHES
 YHRP 0.0000 INCHES
 ZHRP 0.4550 INCHES
 SCALE 0.0035 SCALE

DATA HIST. CODE *EV*6

MSFC TWT 477 NR DELTA WING ORBITER DATA

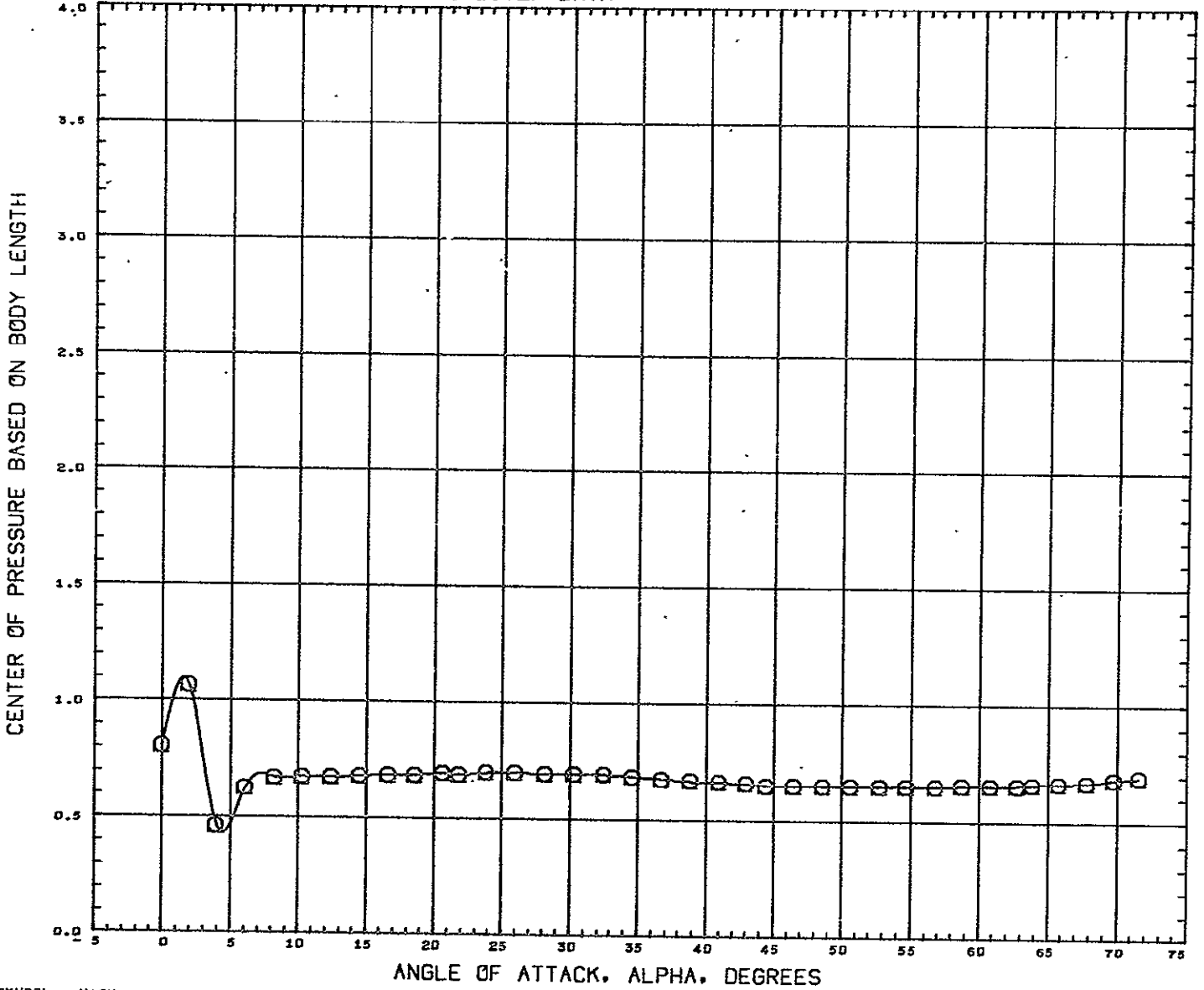

SYMBOL MACH PARAMETRIC VALUES
 O 0.898 BETA 0.000 ELVATR 0.000

REFERENCE INFORMATION
 SREF 0.0745 SQ FT
 LREF 2.8742 INCHES
 BREF 4.9798 INCHES
 XMRP 4.9787 INCHES
 YMRP 0.0000 INCHES
 ZMRP 0.4550 INCHES
 SCALE 0.0035 SCALE

DATA HIST. CODE #EV#6

MSFC TWT 477 NR DELTA WING ORBITER DATA

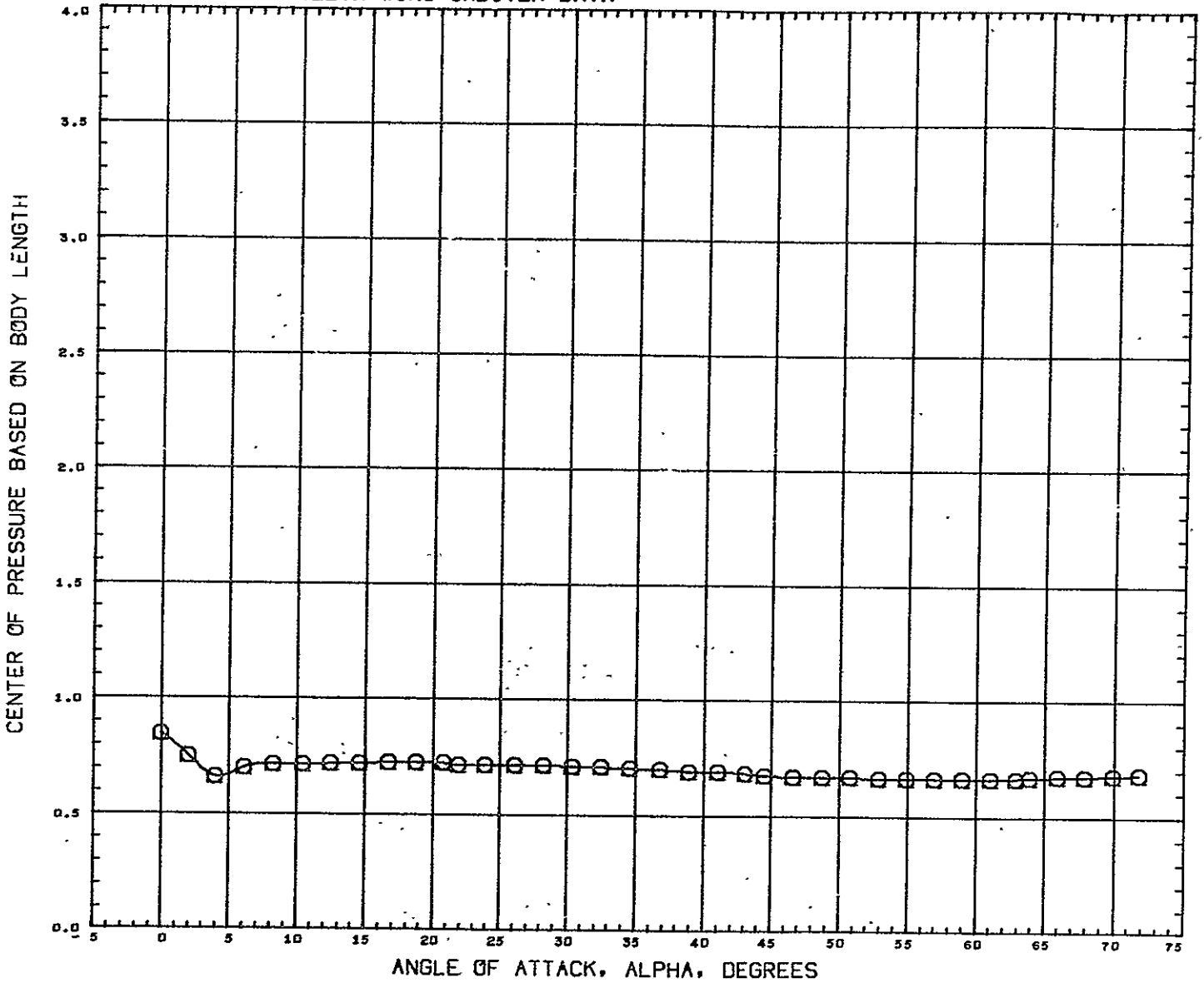

SYMBOL MACH PARAMETRIC VALUES
 O 0.999 BETA 0.000 ELVATR 0.000

REFERENCE INFORMATION
 SREF 0.0745 SQ FT
 LREF 2.8742 INCHES
 BREF 4.9798 INCHES
 XHRP 4.9787 INCHES
 YHRP 0.0000 INCHES
 ZHRP 0.4550 INCHES
 SCALE 0.0035 SCALE

DATA HIST. CODE *EV*G

MSFC TWT 477 NR DELTA WING ORBITER DATA

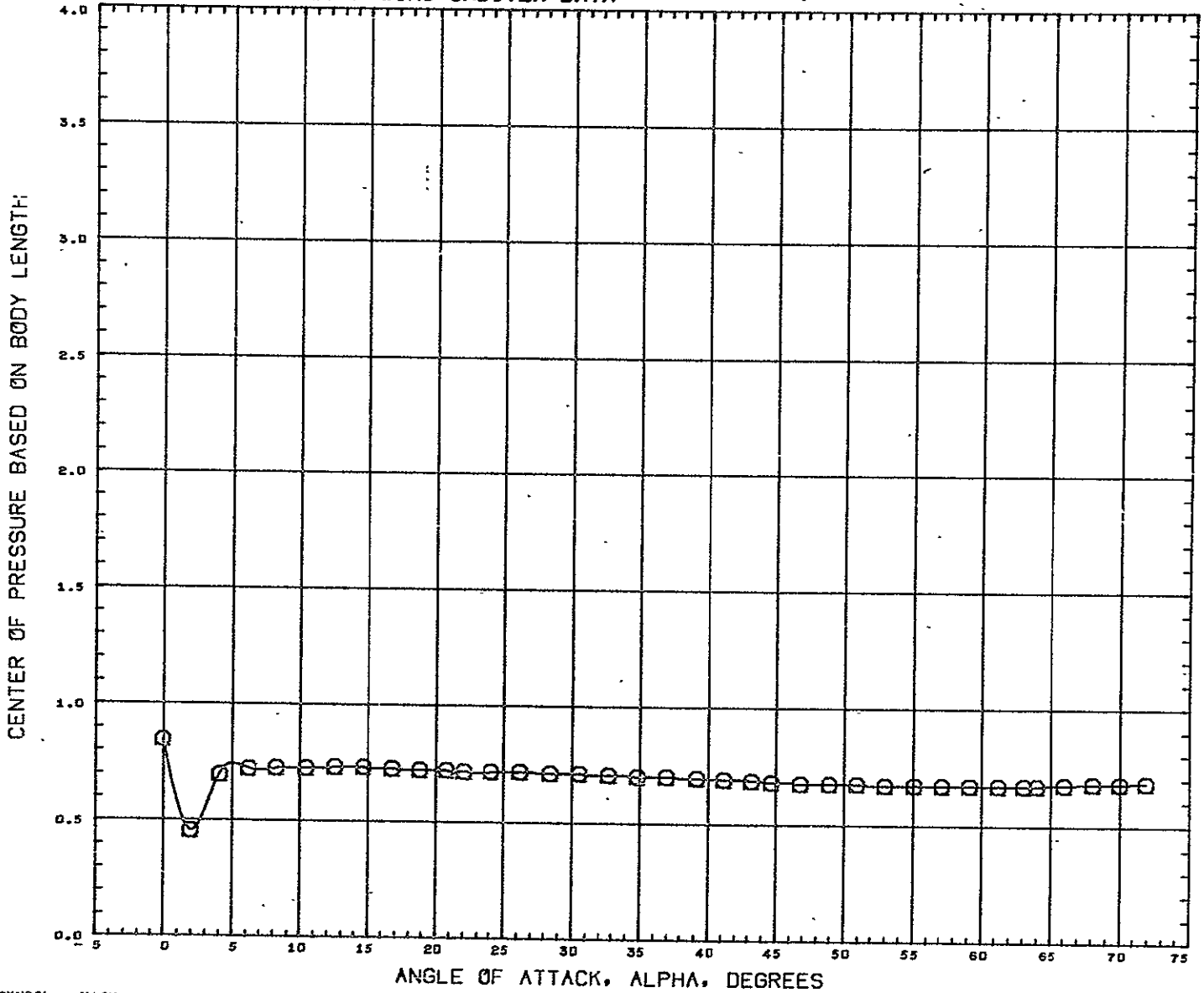

SYMBOL MACH PARAMETRIC VALUES
 O 1.103 BETA 0.000 ELVATR 0.000

REFERENCE INFORMATION
 SREF 0.0745 SQ FT
 LREF 2.8742 INCHES
 BREF 4.9798 INCHES
 XHRP 4.9787 INCHES
 YHRP 0.0000 INCHES
 ZHRP 0.4550 INCHES
 SCALE 0.0035 SCALE

DATA HIST. CODE #EV#6

MSFC TWT 477 NR DELTA WING ORBITER DATA

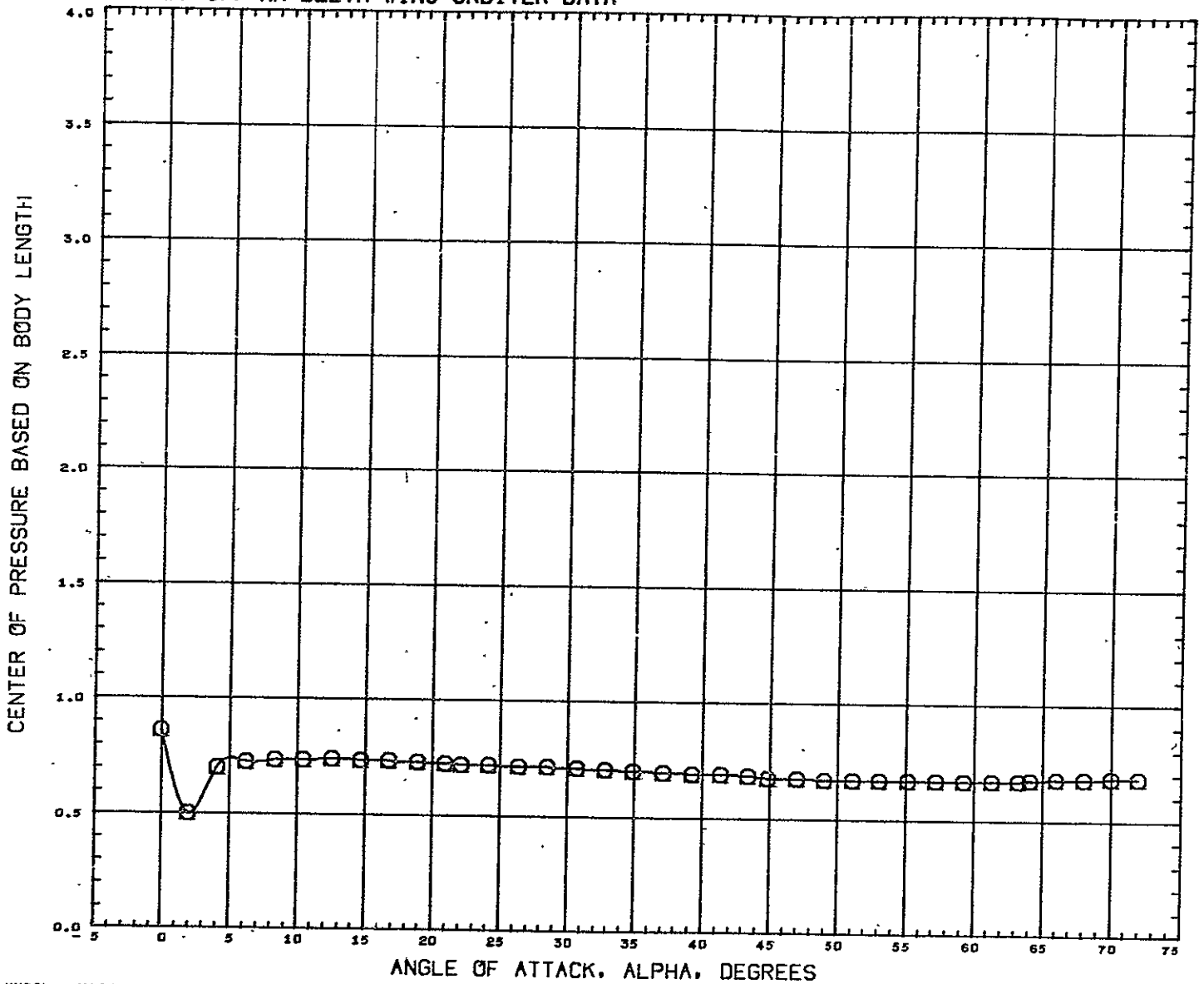

YHBOL MACH PARAMETRIC VALUES
 Q 1.201 BETA 0.000 ELVATR 0.000

REFERENCE INFORMATION
 SREF 0.0745 SQ FT
 LREF 2.8742 INCHES
 DREF 4.9798 INCHES
 XHRF 4.9787 INCHES
 YHRP 0.0000 INCHES
 ZHRP 0.4558 INCHES
 SCALE 0.0035 SCALE

DATA HIST. CODE *EV#0

MSFC TWT 477 NR DELTA WING ORBITER DATA

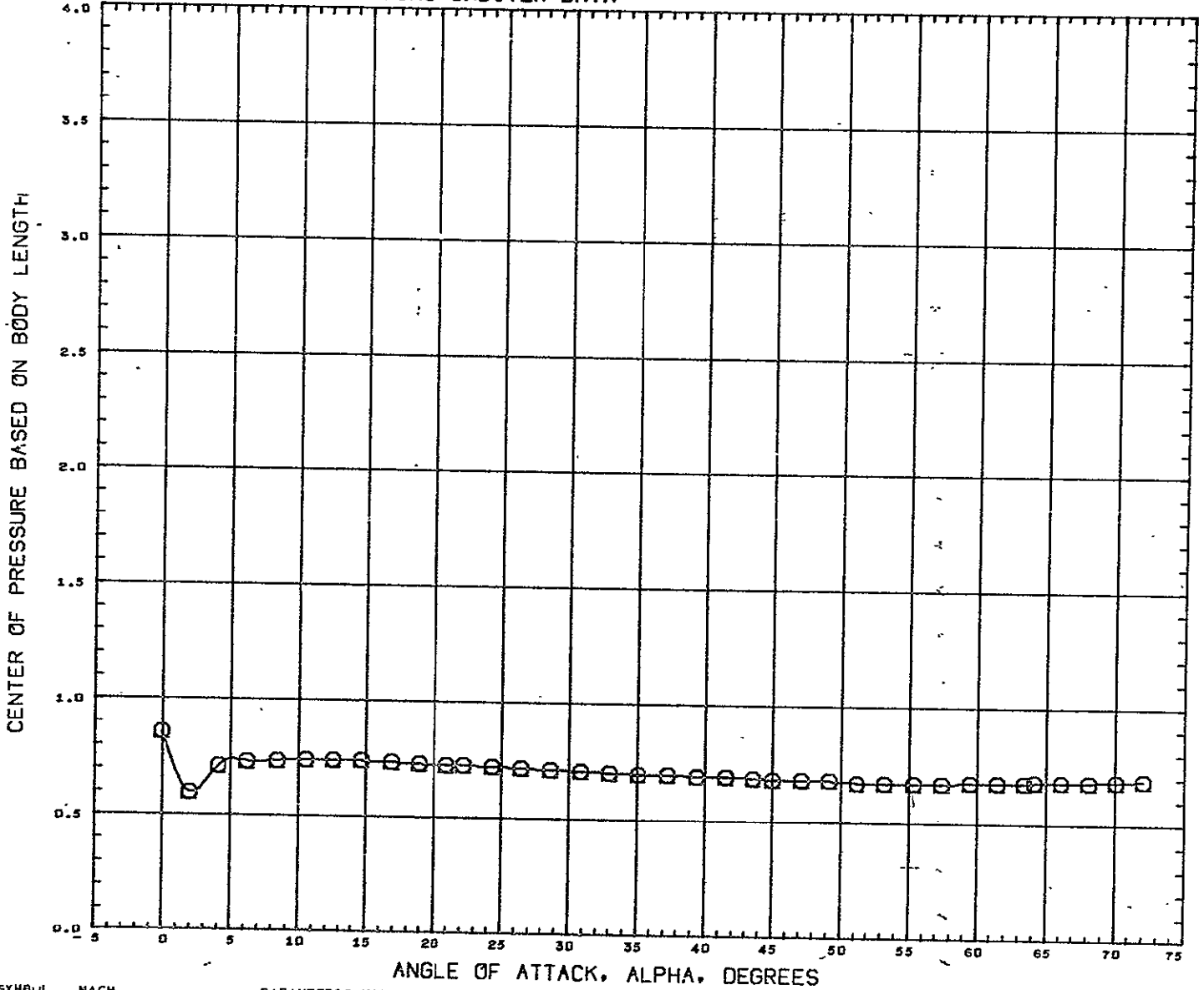

SYMBOL MACH PARAMETRIC VALUES
 O 1.300 BETA 0.000 ELVATR 0.000

REFERENCE INFORMATION

SREF	0.0745	SQ FT
LREF	2.8742	INCHES
BREF	4.9796	INCHES
XMRP	4.9787	INCHES
YMRP	0.0000	INCHES
ZMRP	0.4550	INCHES
SCALE	0.0035	SCALF

DATA HIST. CODE *EV*G

MSFC TWT 477 NR DELTA WING ORBITER DATA

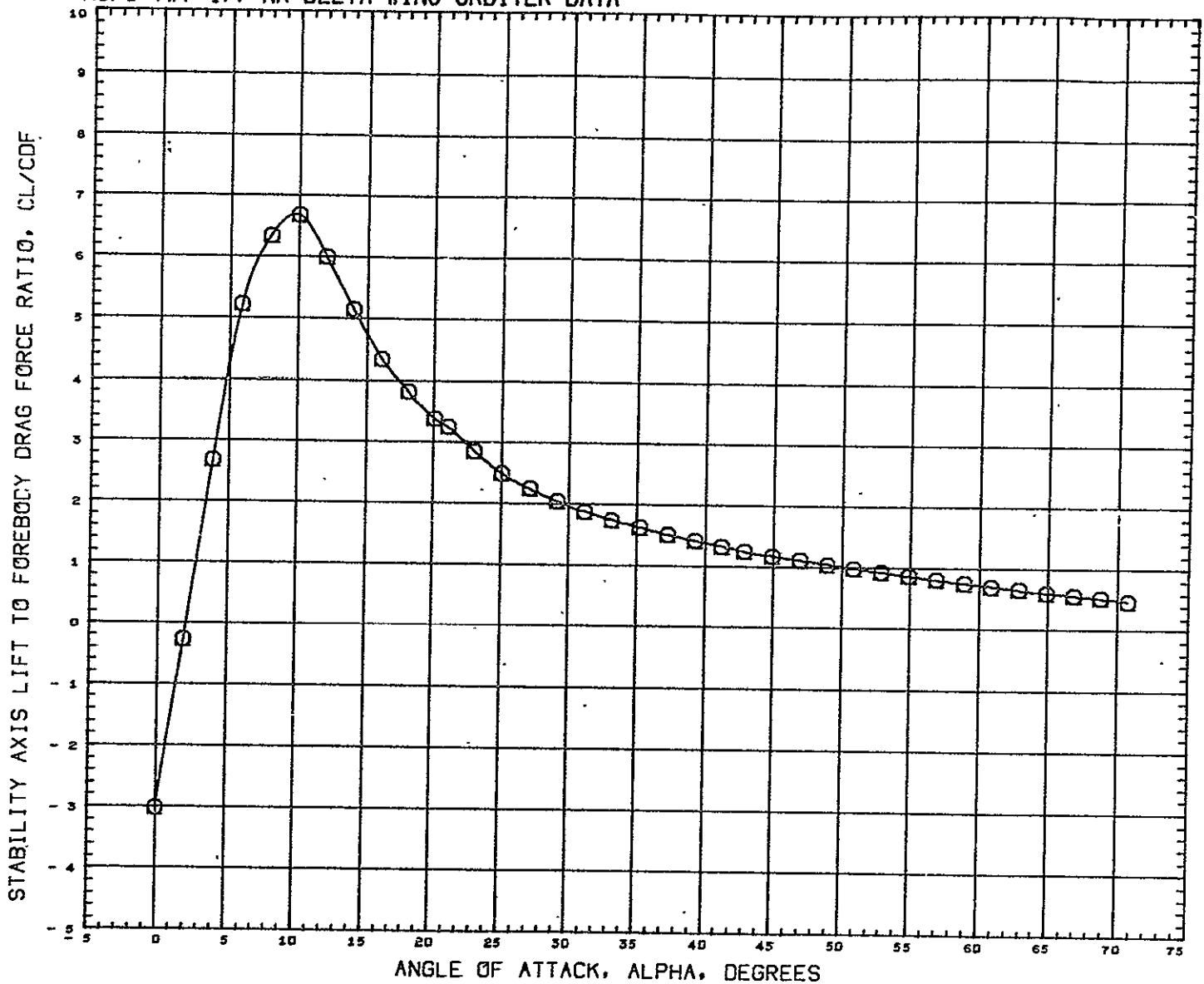

SYMBOL MACH PARAMETRIC VALUES
 O 0.400 BETA 0.000 ELVATR 0.000

REFERENCE INFORMATION
 SREF 0.0745 SQ FT
 LREF 2.8742 INCHES
 BREF 4.9798 INCHES
 XMRP 4.9787 INCHES
 YMRP 0.0000 INCHES
 ZMRP 0.4550 INCHES
 SCALE 0.0035 SCALE

DATA HIST. CODE #EV*G

MSFC TWT 477 NR DELTA WING ORBITER DATA

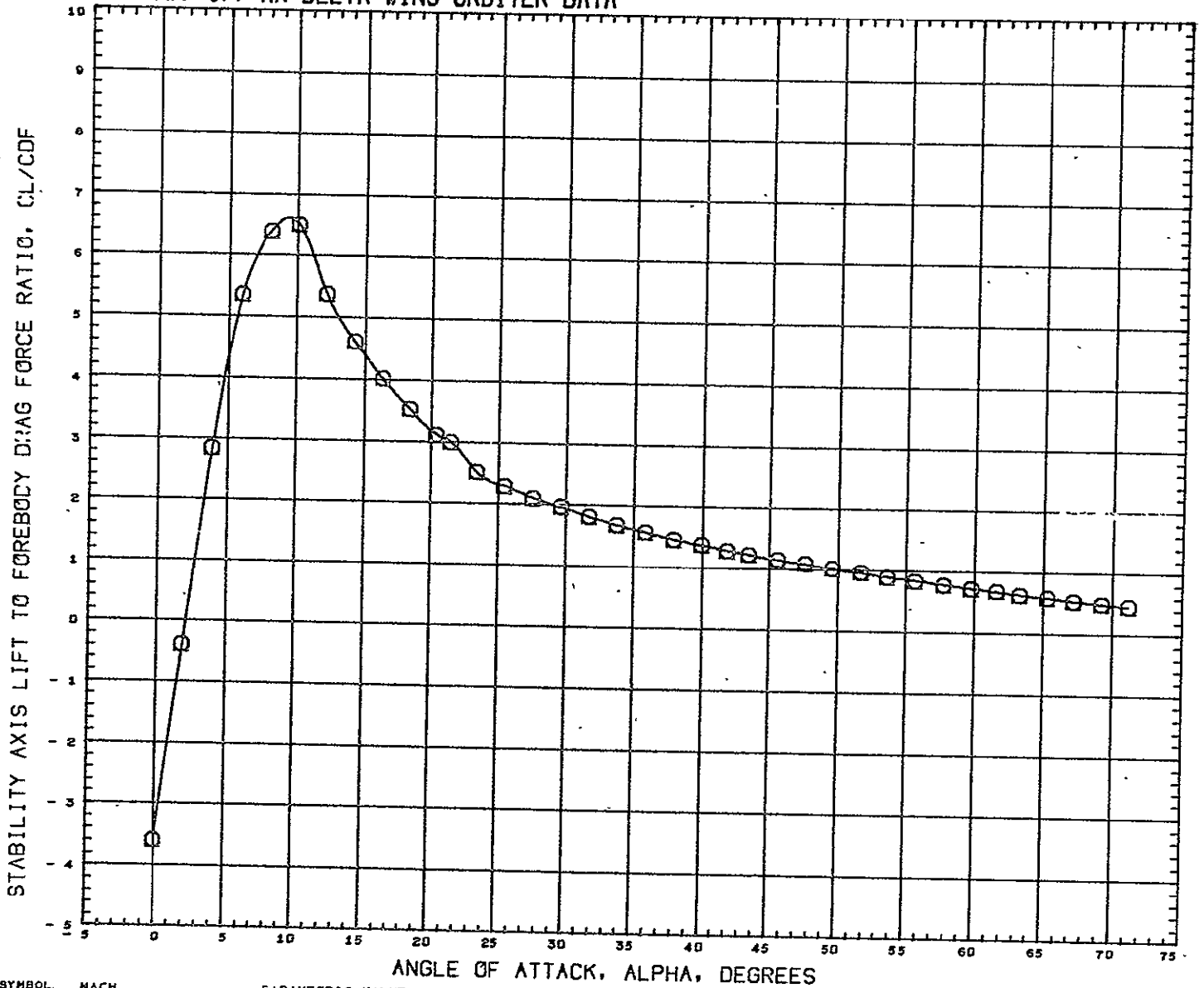

SYMBOL: \square MACH: 0.598 BETA: 0.000 ELVATR: 0.000

REFERENCE INFORMATION

SREF	0.0745	SQ FT
LREF	2.8742	INCHES
BREF	4.9798	INCHES
XMRP	4.9787	INCHES
YMRP	0.0000	INCHES
ZMRP	0.4550	INCHES
SCALE	0.0035	SCALE

DATA HIST. CODE #EV#6

MSFC TWT 477 NR DELTA WING ORBITER DATA

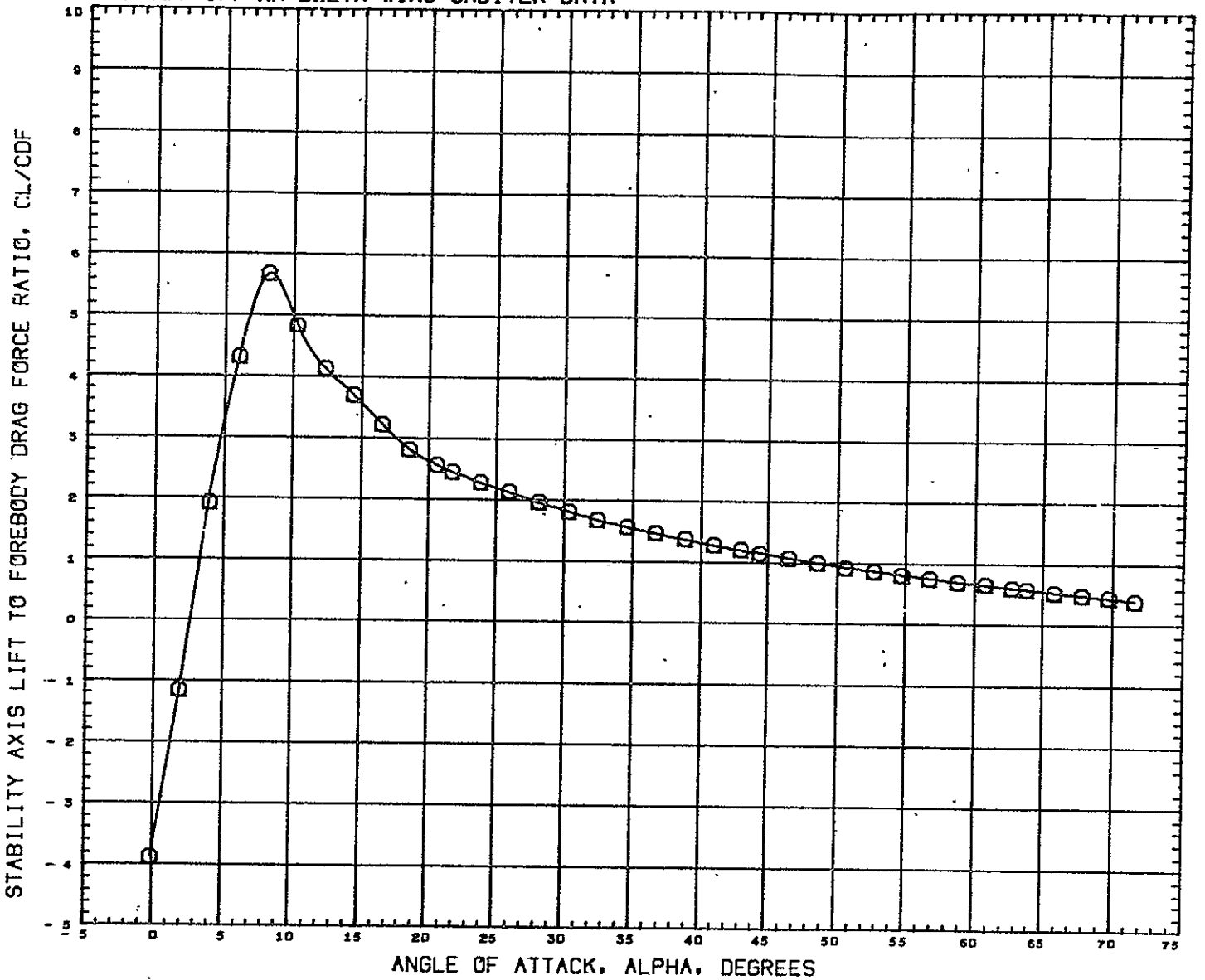

SYMBOL MACH PARAMETRIC VALUES
 O 0.898 BETA 0.000 ELVATR 0.000

REFERENCE INFORMATION
 SREF 0.0745 SQ FT
 LREF 2.8742 INCHES
 BREF 4.9798 INCHES
 XMRP 4.9787 INCHES
 YMRP 0.0000 INCHES
 ZMRP 0.4550 INCHES
 SCALE 0.0035 SCALE

DATA HIST. CODE #EV*G

MSFC TWT 477 NR DELTA WING ORBITER DATA

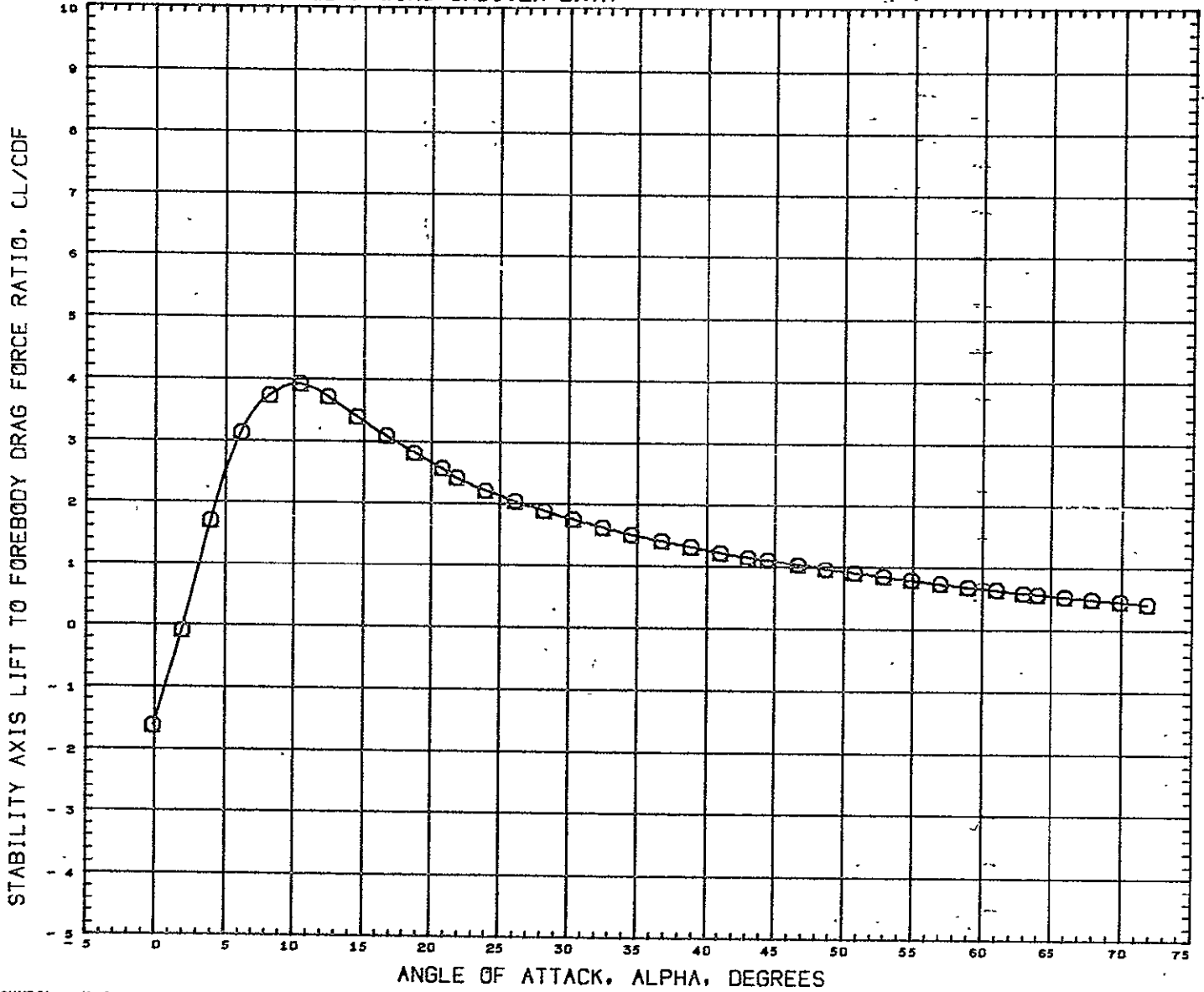

SYMBOL Q MACH 0.999 BETA 0.000 ELVATR 0.000

REFERENCE INFORMATION
 SREF 0.0745 SQ FT
 LREF 2.8742 INCHES
 BREF 4.9798 INCHES
 XMRP 4.9787 INCHES
 YMRP 0.0000 INCHES
 ZMRP 0.4550 INCHES
 SCALE 0.0035 SCALE

DATA HIST. CODE #EV#6

MSFC TWT 477 NR DELTA WING ORBITER DATA

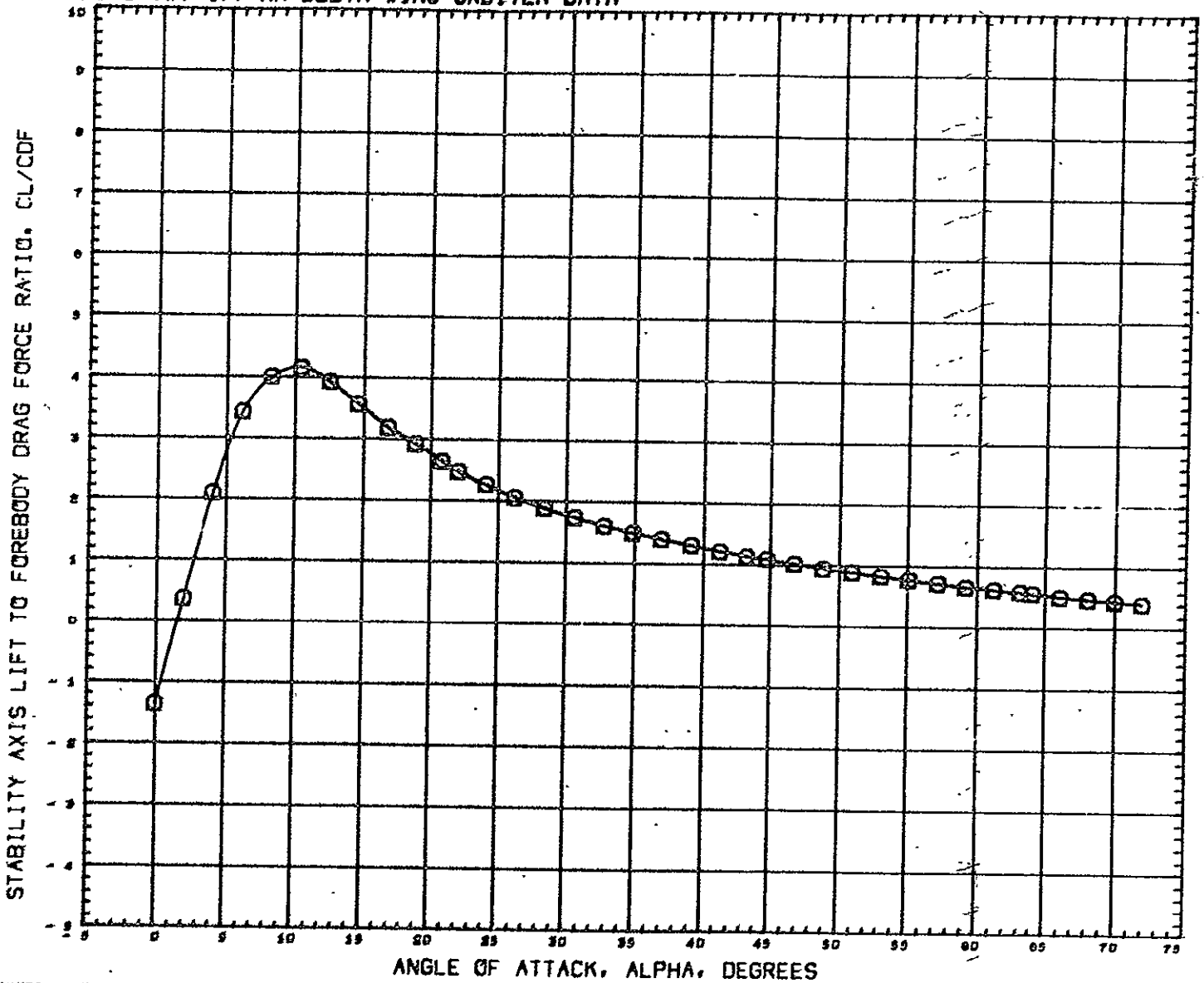

SYMBOL \square MACH 1.103 BETA 0.000 ELVATR 0.000
 PARAMETRIC VALUES

REFERENCE INFORMATION
 SREF 0.0745 SQ FT
 LREF 2.8742 INCHES
 BREF 4.9798 INCHES
 XMRP 4.9787 INCHES
 YMRP 0.0000 INCHES
 ZMRP 0.4550 INCHES
 SCALE 0.0039 SCALE

DATA HIST. CODE REV#6

MSFC TWT 477 NR DELTA WING ORBITER DATA

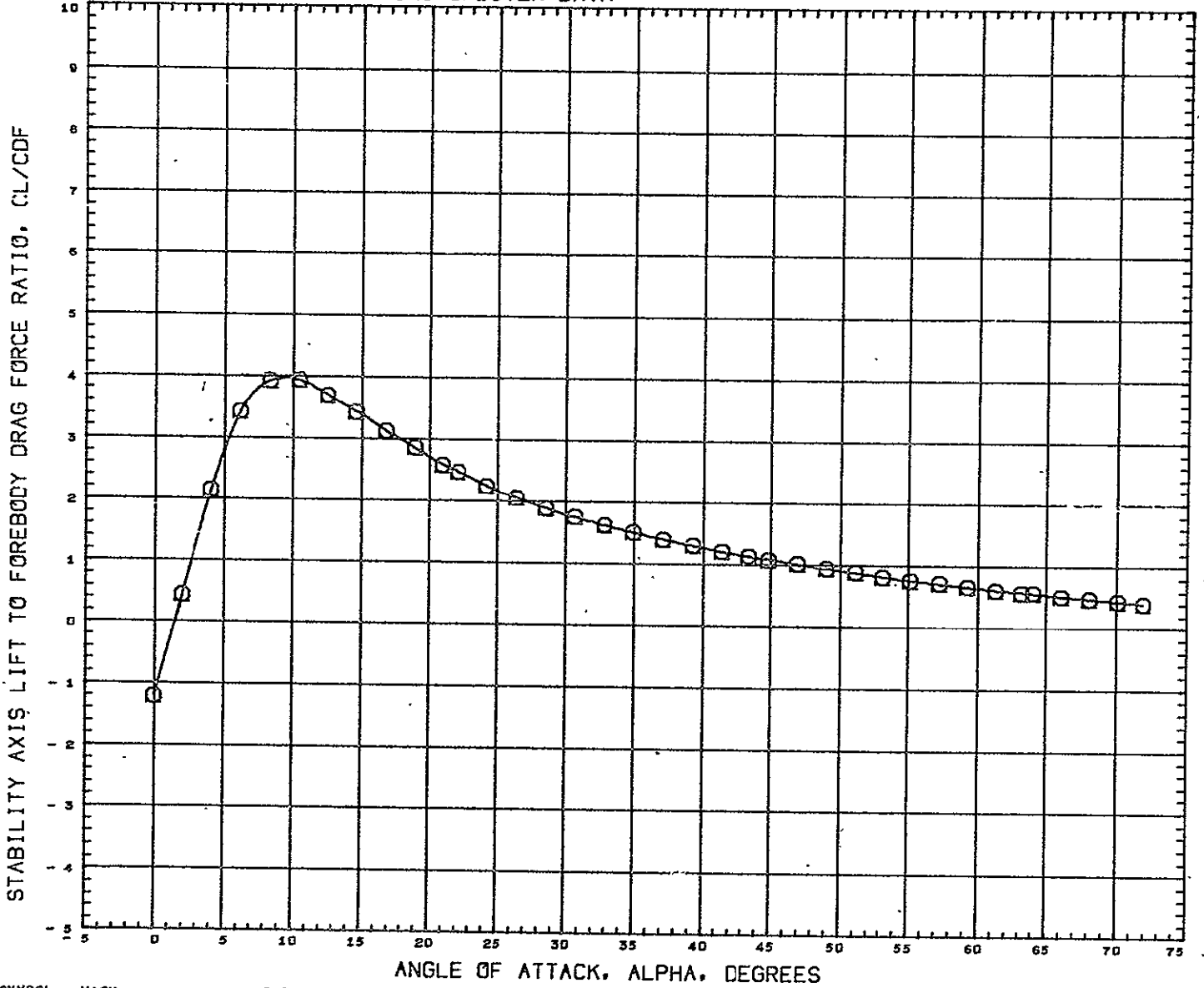

SYMBOL MACH PARAMETRIC VALUES
 O 1.201 BETA 0.000 ELVATR 0.000

REFERENCE INFORMATION
 SREF 0.0745 SQ FT
 LREF 2.8742 INCHES
 BREF 4.9798 INCHES
 XMRP 4.9787 INCHES
 YMRP 0.0000 INCHES
 ZMRP 0.4550 INCHES
 SCALE 0.0035 SCALE

DATA HIST. CODE #EV#6

MSFC TWT 477 NR DELTA WING ORBITER DATA

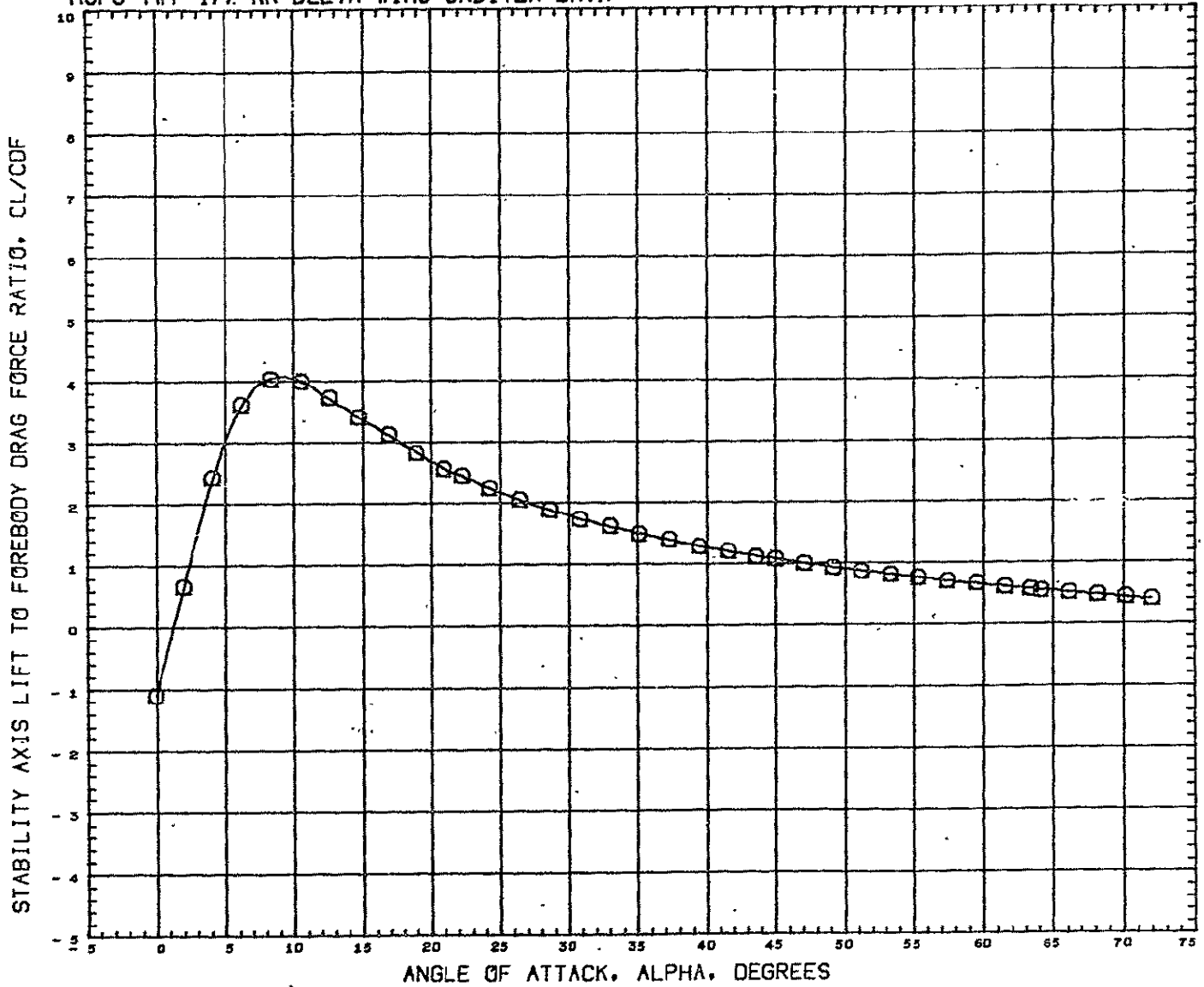

SYMBOL MACH PARAMETRIC VALUES
 O 1.300 BETA 0.000 ELVATR 0.000

REFERENCE INFORMATION
 SREF 0.0745 SQ FT
 LREF 2.8742 INCHES
 BREF 4.9798 INCHES
 XMRP 4.9787 INCHES
 YMRP 0.0000 INCHES
 ZMRP 0.4550 INCHES
 SCALE 0.0035 SCALE

DATA HIST. CODE #EV#G

MSFC TWT 477 NR DELTA WING ORBITER DATA

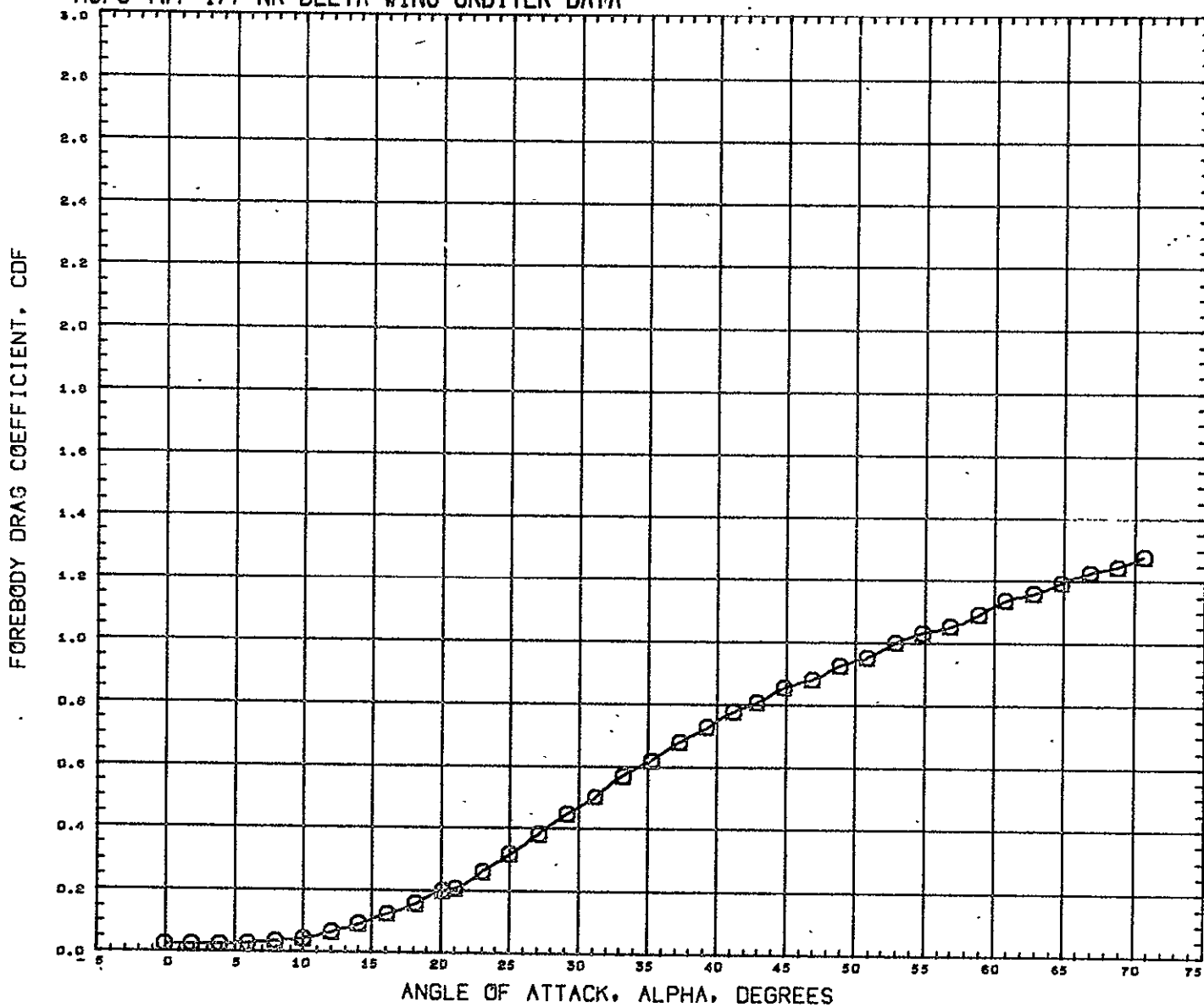

SYMBOL MACH BETA PARAMETRIC VALUES
 Q 0.400 0.000 ELVATR 0.000

REFERENCE INFORMATION

SREF	0.0745	SQ FT
LREF	2.8742	INCHES
BREF	4.9798	INCHES
XMRP	4.9787	INCHES
YMRP	0.0000	INCHES
ZMRP	0.4550	INCHES
SCALE	0.0035	SCALE

DATA HIST. CODE #EV46

MSFC TWT 477 NR DELTA WING ORBITER DATA

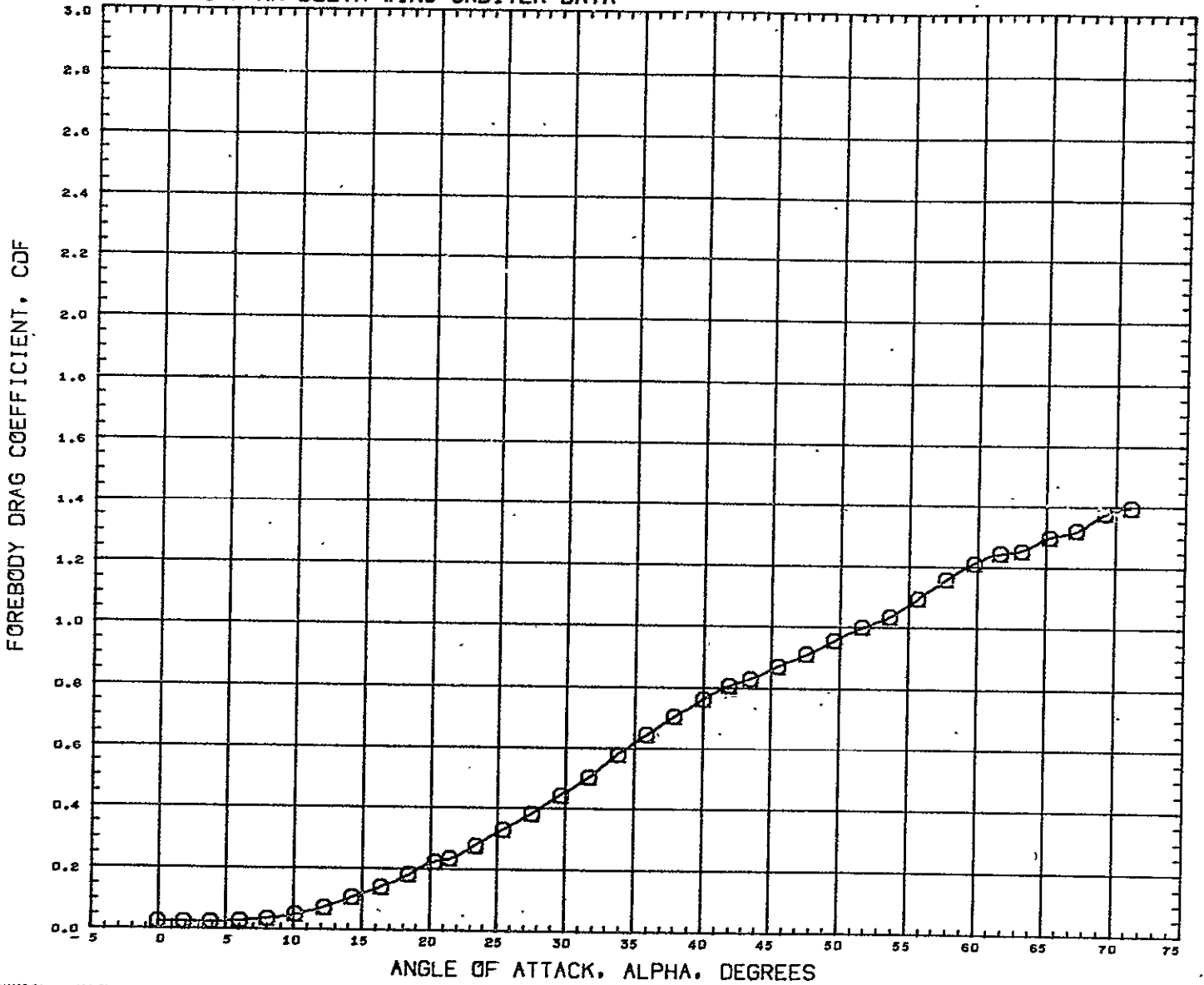

SYMBOL MACH PARAMETRIC VALUES
 O 0.598 BETA 0.000 ELVATR 0.000

REFERENCE INFORMATION
 SREF 0.0745 SQ FT
 LREF 2.8742 INCHES
 BREF 4.9798 INCHES
 XMRP 4.9787 INCHES
 YMRP 0.0000 INCHES
 ZMRP 0.4550 INCHES
 SCALE 0.0035 SCALE

DATA HIST. CODE *EV*G

MSFC TWT 477 NR DELTA WING ORBITER DATA

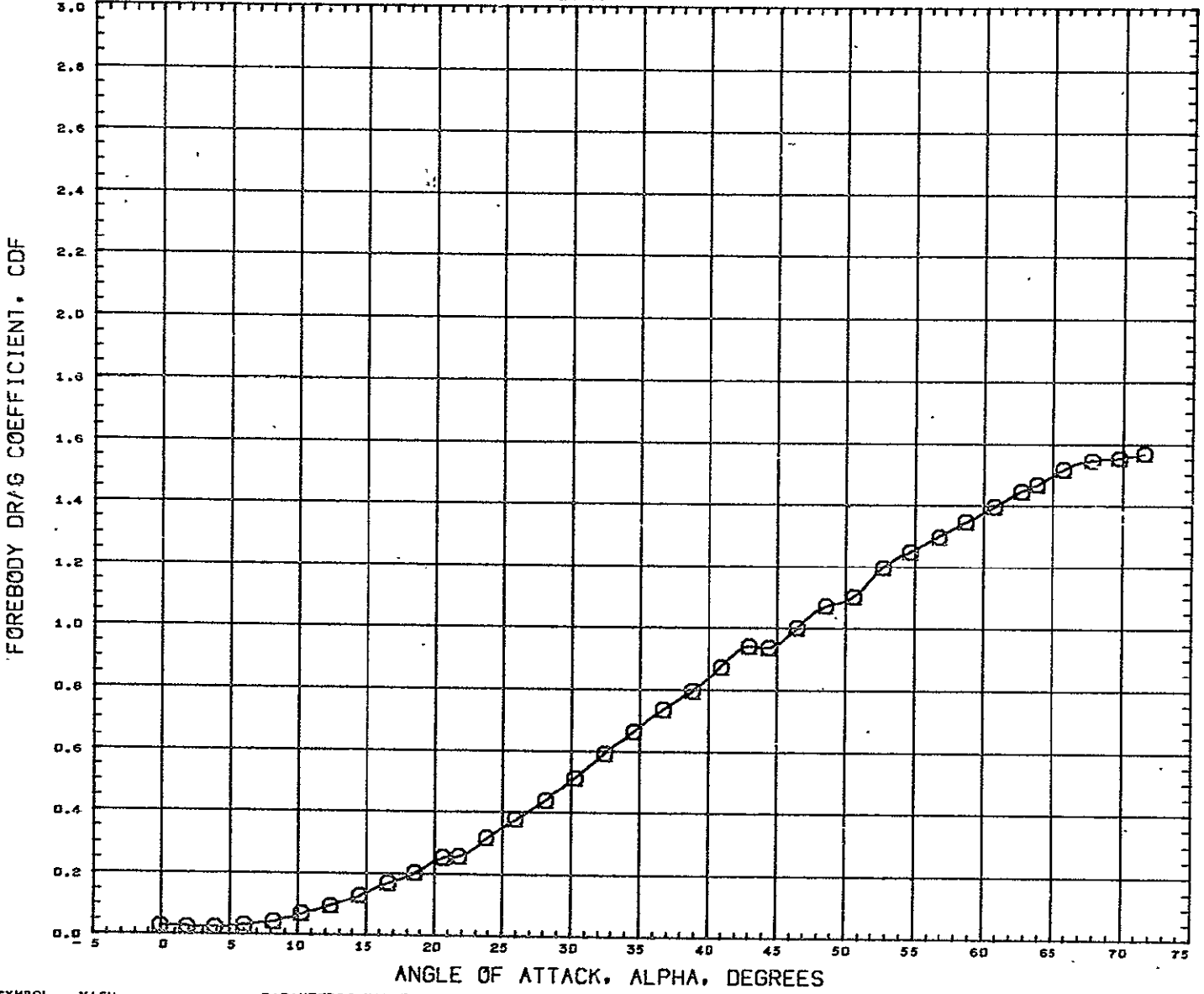

SYMBOL \square MACH 0.898 BETA 0.000 ELVATR 0.000

REFERENCE INFORMATION
 SREF 0.0745 SQ FT
 LREF 2.8742 INCHES
 BREF 4.9798 INCHES
 XMRP 4.9787 INCHES
 YMRP 0.0000 INCHES
 ZMRP 0.4550 INCHES
 SCALE 0.0035 SCALE

DATA HIST. CODE #EV*G

MSFC TWT 477 NR DELTA WING ORBITER DATA

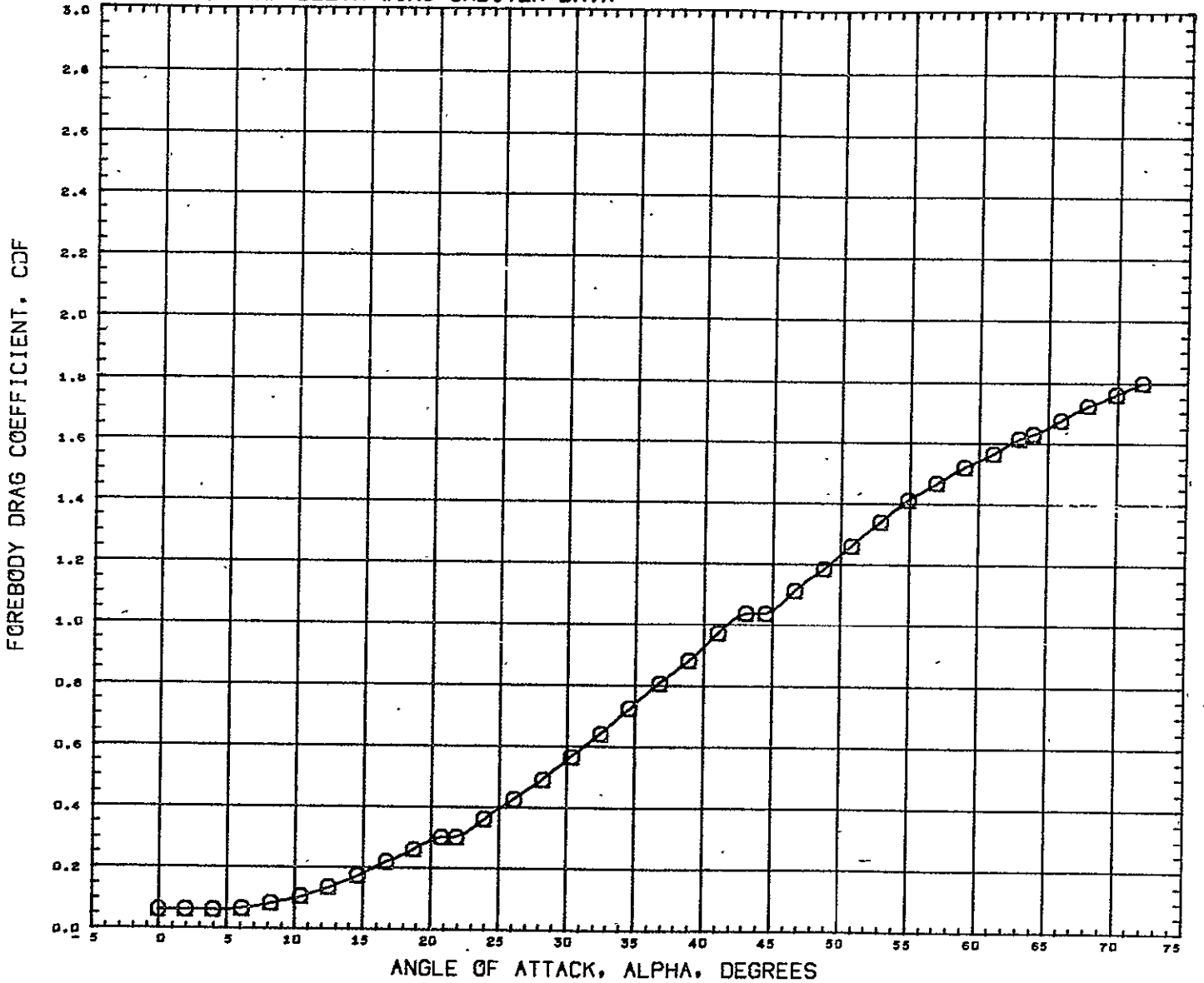

SYMBOL MACH PARAMETRIC VALUES
 ○ 0.999 BETA 0.000 ELVATR 0.000

REFERENCE INFORMATION
 SREF 0.0745 SQ FT
 LREF 2.8742 INCHES
 BREF 4.9798 INCHES
 XMRP 4.9787 INCHES
 YMRP 0.0000 INCHES
 ZMRP 0.4550 INCHES
 SCALE 0.0035 SCALE

DATA HIST. CODE *EV46

MSFC TWT 477 NR DELTA WING ORBITER DATA

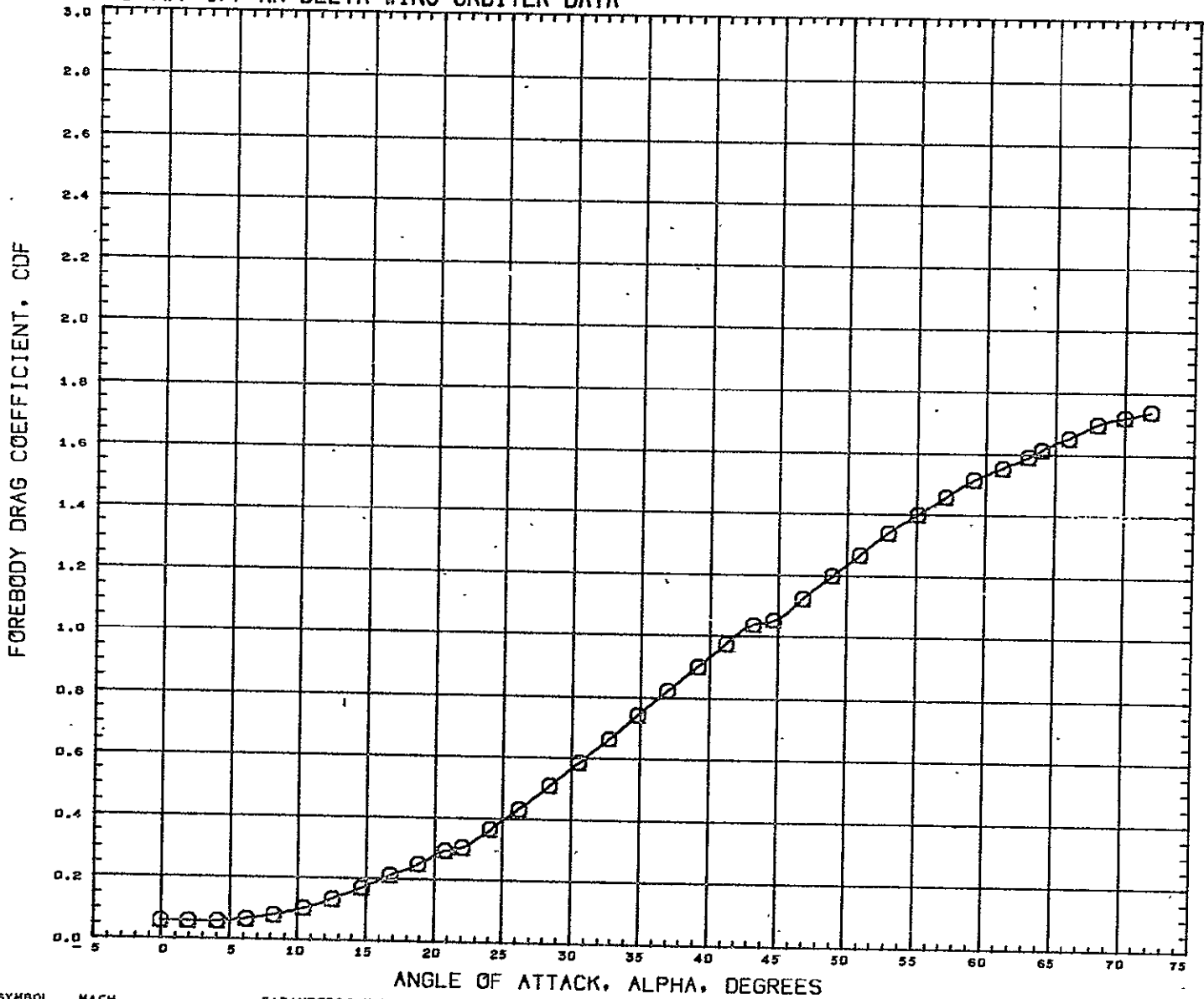

SYMBOL MACH PARAMETRIC VALUES
 O 1.103 BETA 0.000 ELVATR 0.000

REFERENCE INFORMATION
 SREF 0.0745 SQ FT
 LREF 2.8742 INCHES
 BREF 4.9798 INCHES
 XMRP 4.9787 INCHES
 YMRP 0.0000 INCHES
 ZMRP 0.4550 INCHES
 SCALE 0.0035 SCALE

DATA HIST. CODE *EV*6

MSFC TWT 477 NR DELTA WING ORBITER DATA

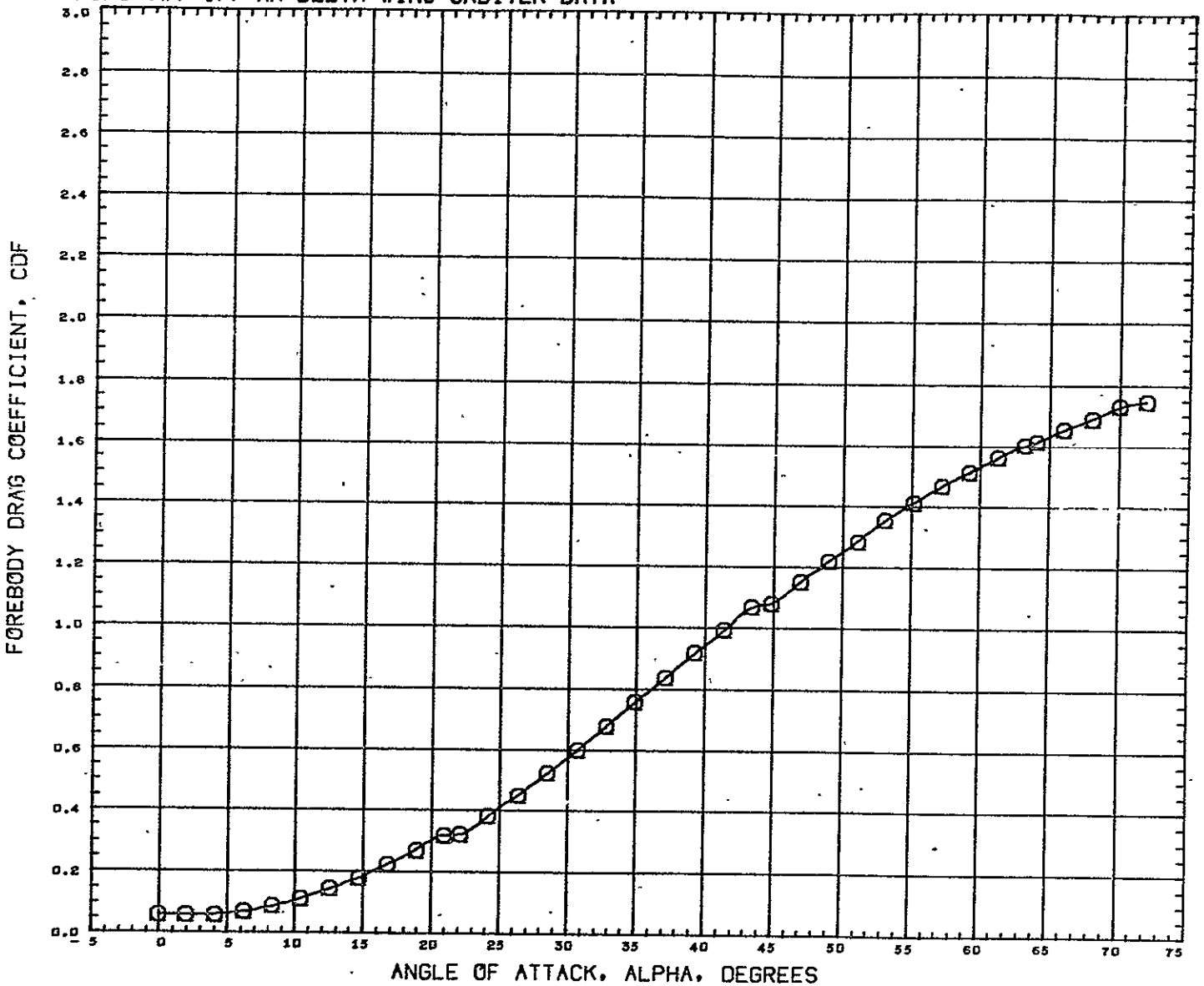

SYMBOL MACH PARAMETRIC VALUES
 O 1.201 BETA 0.000 ELVATR 0.000

REFERENCE INFORMATION
 SREF 0.0745 SQ FT
 LREF 2.8742 INCHES
 BREF 4.9798 INCHES
 XMRP 4.9787 INCHES
 YMRP 0.0000 INCHES
 ZMRP 0.4550 INCHES
 SCALE 0.0035 SCALE

DATA HIST. CODE *EV*6

MSFC TWT 477 NR DELTA WING ORBITER DATA

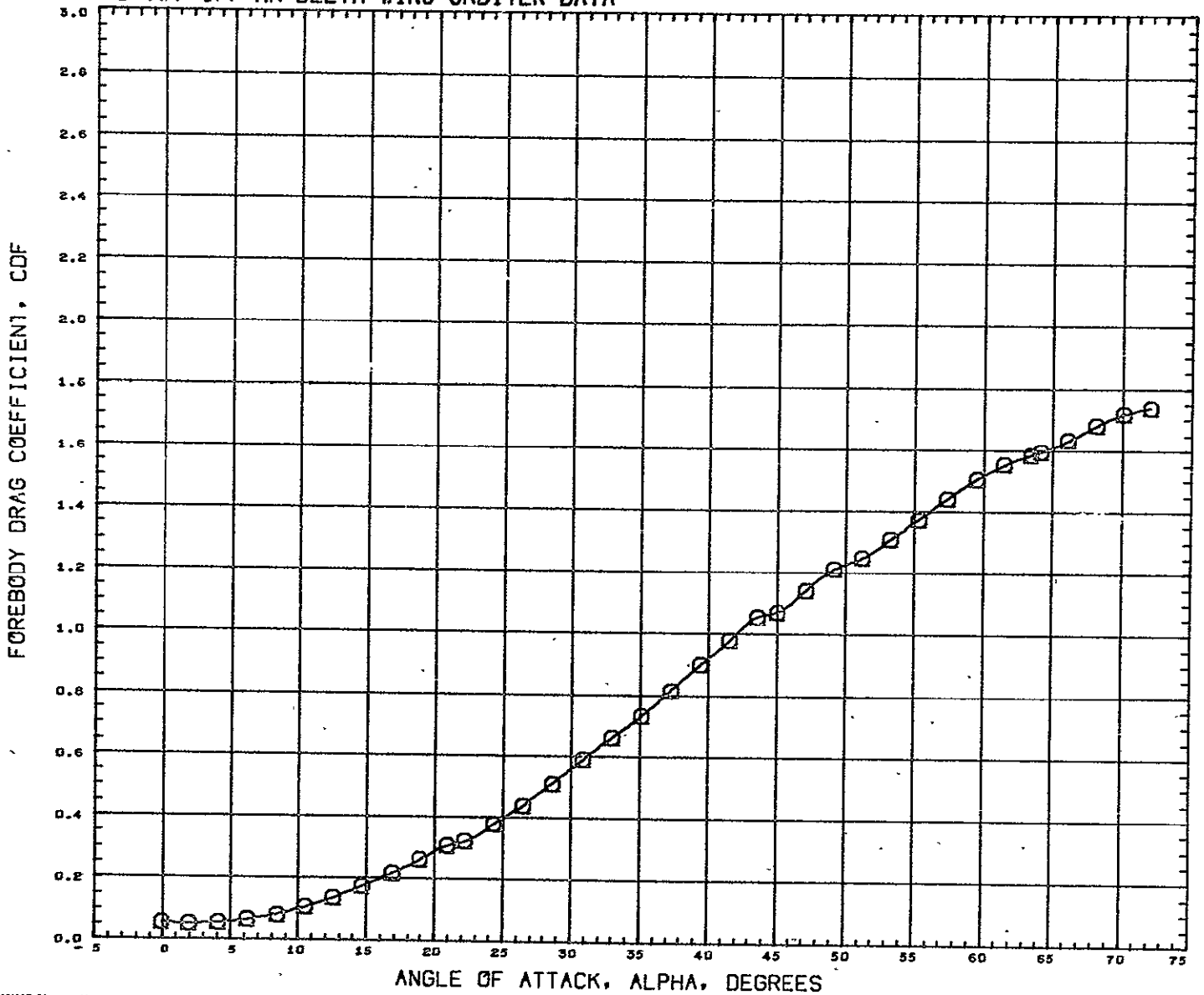

SYMBOL MACH PARANETRIC VALUES
 O 1.300 BETA 0.005 ELVATR 0.000

REFERENCE INFORMATION
 SREF 0.0745 SQ FT
 LREF 2.8742 INCHES
 BREF 4.9798 INCHES
 XHRP 4.9787 INCHES
 YHRP 0.0000 INCHES
 ZHRP 0.4550 INCHES
 SCALE 0.0035 SCALE

DATA HIST. CODE #EV#6

MSFC TWT 477 NR DELTA WING ORBITER DATA

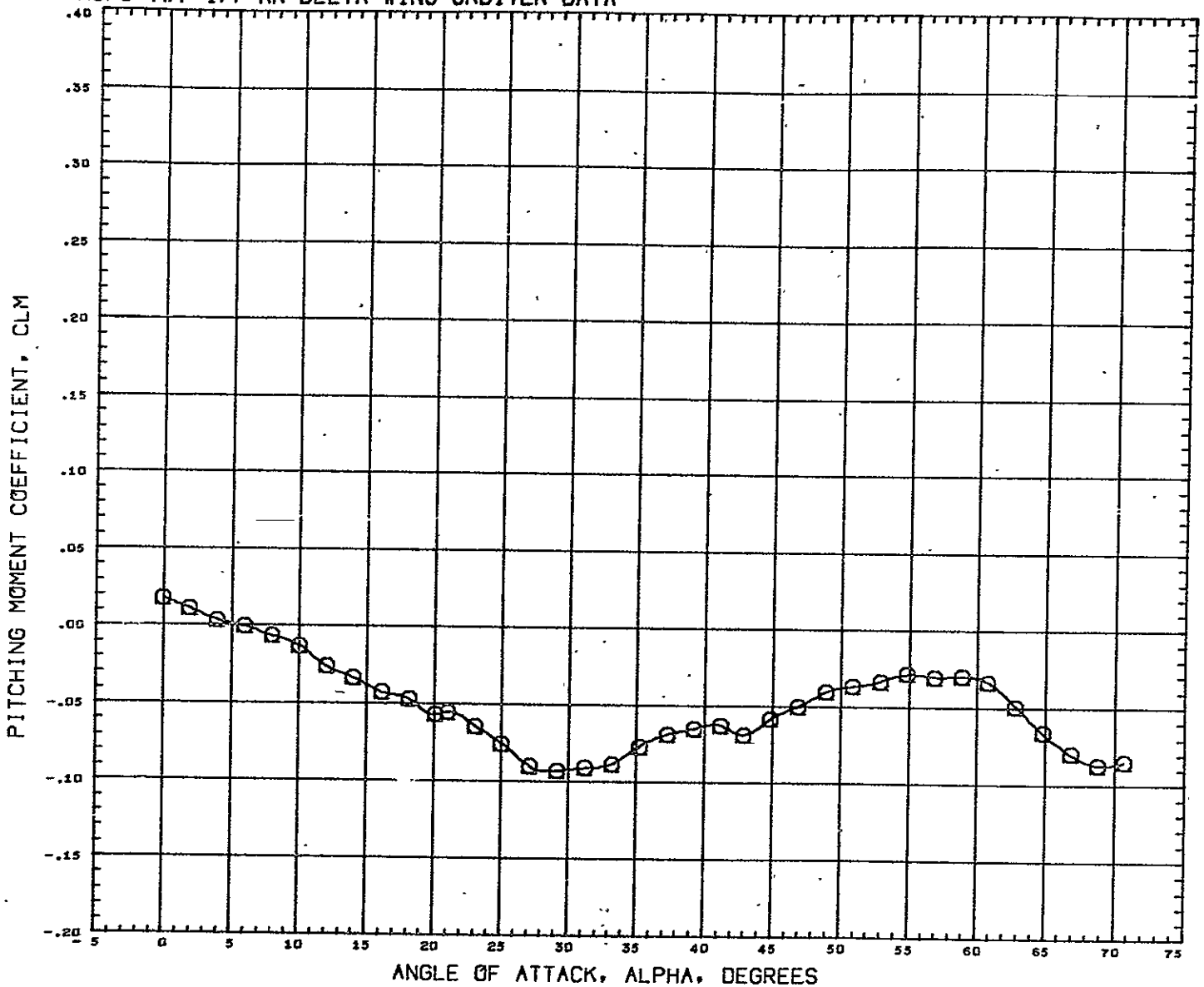

SYMBOL MACH PARAMETRIC VALUES
 O 0.400 BETA 0.000 ELVATR 0.000

REFERENCE INFORMATION
 SREF 0.0745 SQ FT
 LREF 2.8742 INCHES
 BREF 4.9798 INCHES
 XMRP 4.9787 INCHES
 YMRP 0.0000 INCHES
 ZMRP 0.4550 INCHES
 SCALE 0.0035 SCALE

DATA HIST. CODE #EV*6

MSFC TWT 477 NR DELTA WING ORBITER DATA

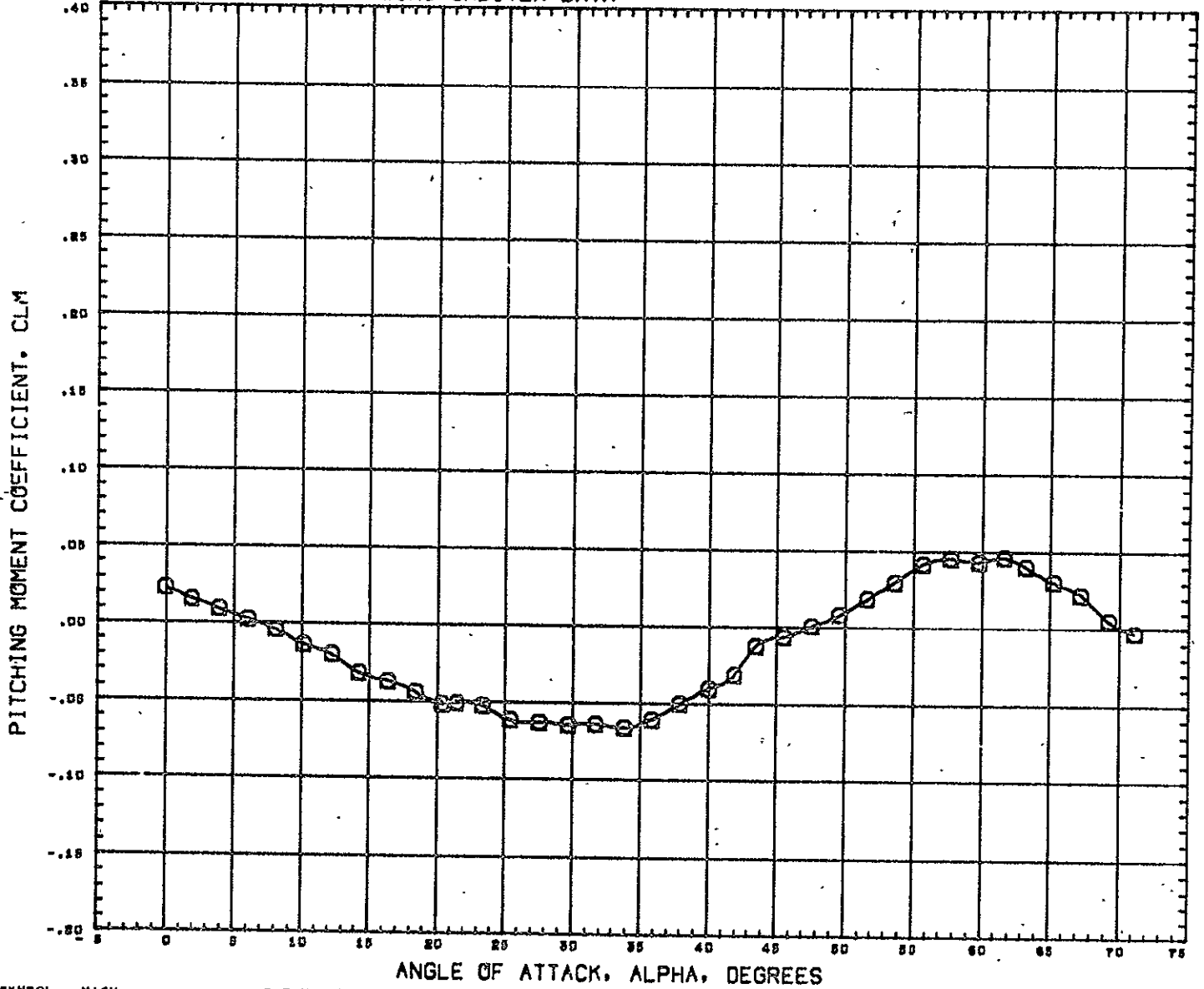

SYMBOL MACH PARAMETRIC VALUES
 ○ 0.800 BETA 0.000 ELVATR 0.000

REFERENCE INFORMATION
 SREF 0.0745 SQ FT
 LREF 2.8742 INCHES
 OREF 4.8790 INCHES
 XNRP 4.8767 INCHES
 YNRP 0.0000 INCHES
 ZNRP 0.4880 INCHES
 SCALE 0.0035 SCALE

DATA HIST. CODE *ZY*G

MSFC TWT 477 NR DELTA WING ORBITER DATA

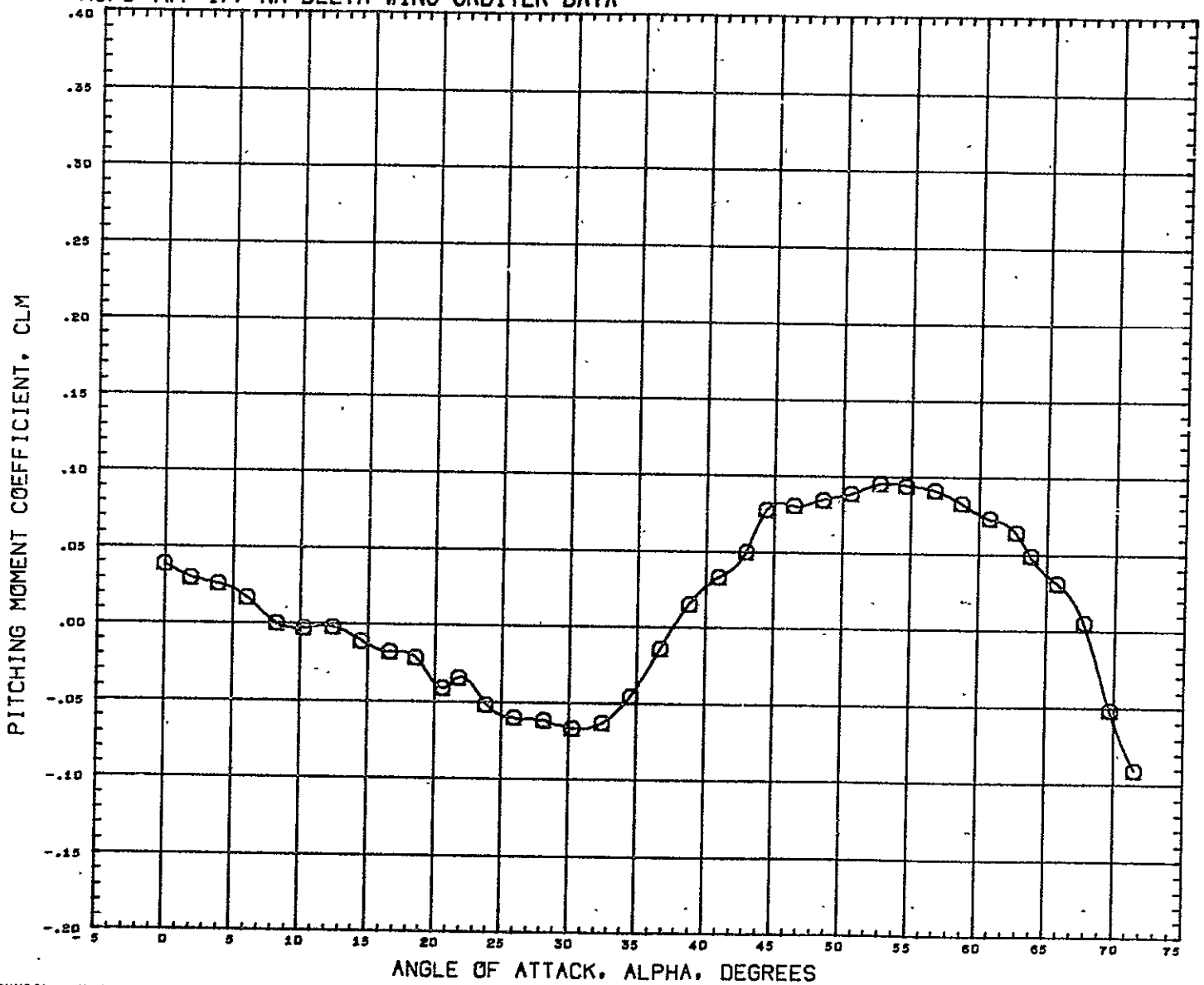

SYMBOL \square MACH 0.898 BETA 0.000 ELVATR 0.000

PARAMETRIC VALUES

REFERENCE INFORMATION

SREF	0.0745	SQ FT
LREF	2.6742	INCHES
BREF	4.9798	INCHES
XMRP	4.9787	INCHES
YMRP	0.0000	INCHES
ZMRP	0.4550	INCHES
SCALE	0.0035	SCALE

DATA HIST. CODE #EV*6

MSFC TWT 477 NR DELTA WING ORBITER DATA

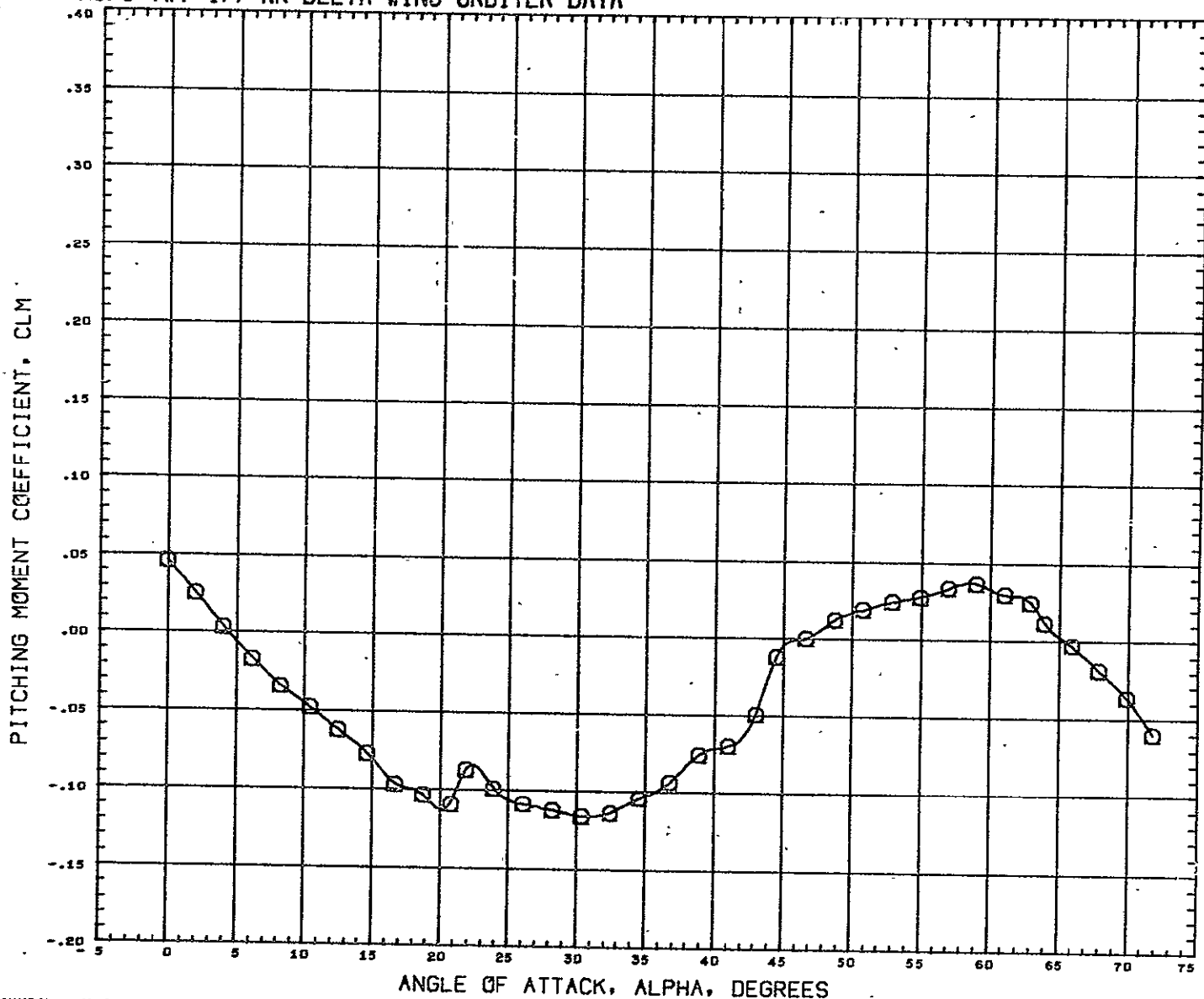

SYMSOL HACH PARAMETRIC VALUES
 O 0.999 BETA 0.000 ELVATR 0.000

REFERENCE INFORMATION
 SREF 0.0745 SQ FT
 LREF 2.8742 INCHES
 BREF 4.9798 INCHES
 XMRP 4.9787 INCHES
 YMRP 0.0000 INCHES
 ZMRP 0.4550 INCHES
 SCALE 0.0035 SCALE

DATA HIST. CODE #EV#G

MSFC TWT 477 NR DELTA WING ORBITER DATA

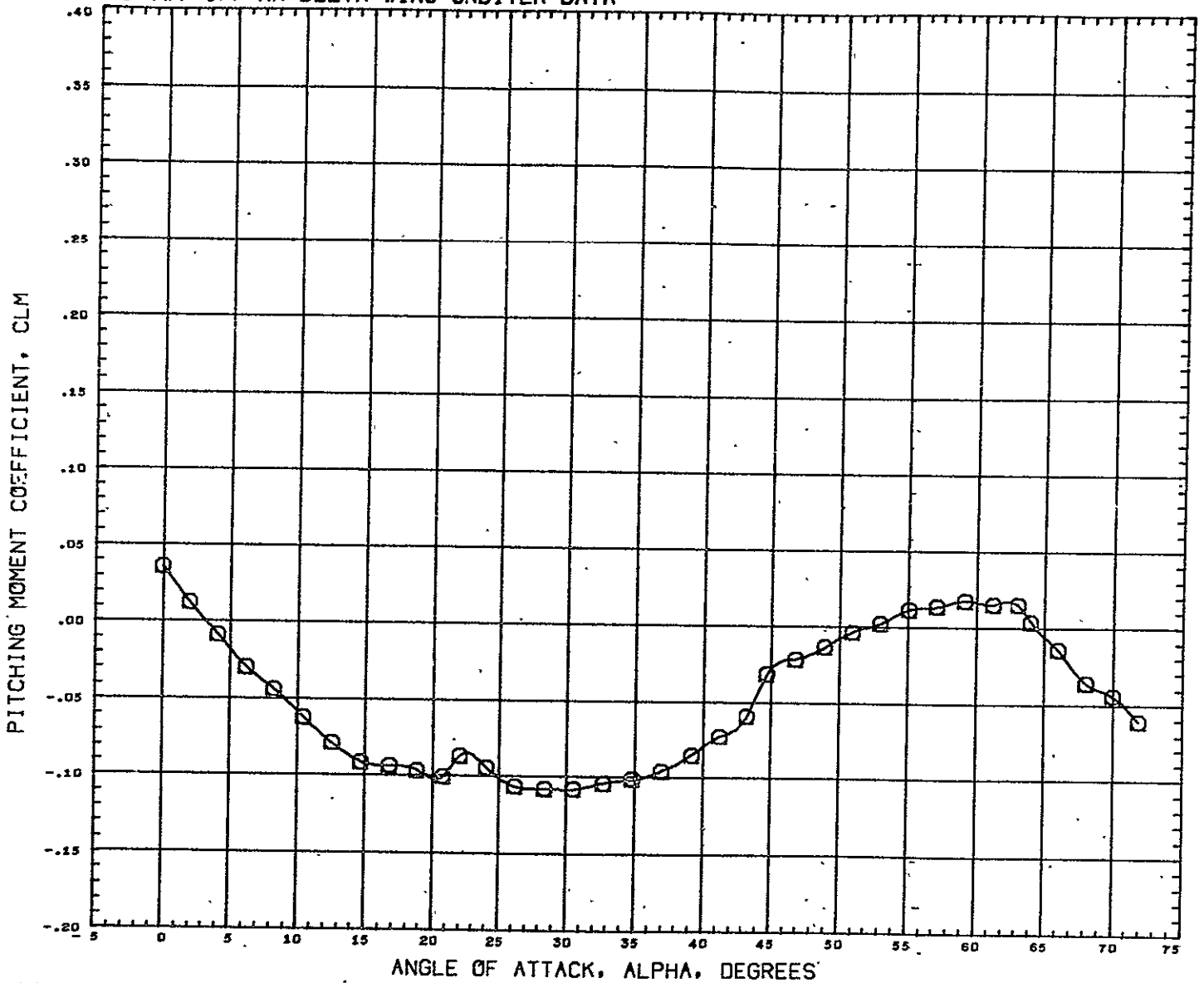

SYMBOL \square MACH 1.103 BETA 0.000 ELVATR 0.000

REFERENCE INFORMATION

SREF	0.0745	SQ FT
LREF	2.8742	INCHES
BREF	4.9798	INCHES
XHRP	4.9787	INCHES
YHRP	0.0000	INCHES
ZHRP	0.4550	INCHES
SCALE	0.0035	SCALE

DATA HIST. CODE *EV*G

MSFC TWT 477 NR DELTA WING ORBITER DATA

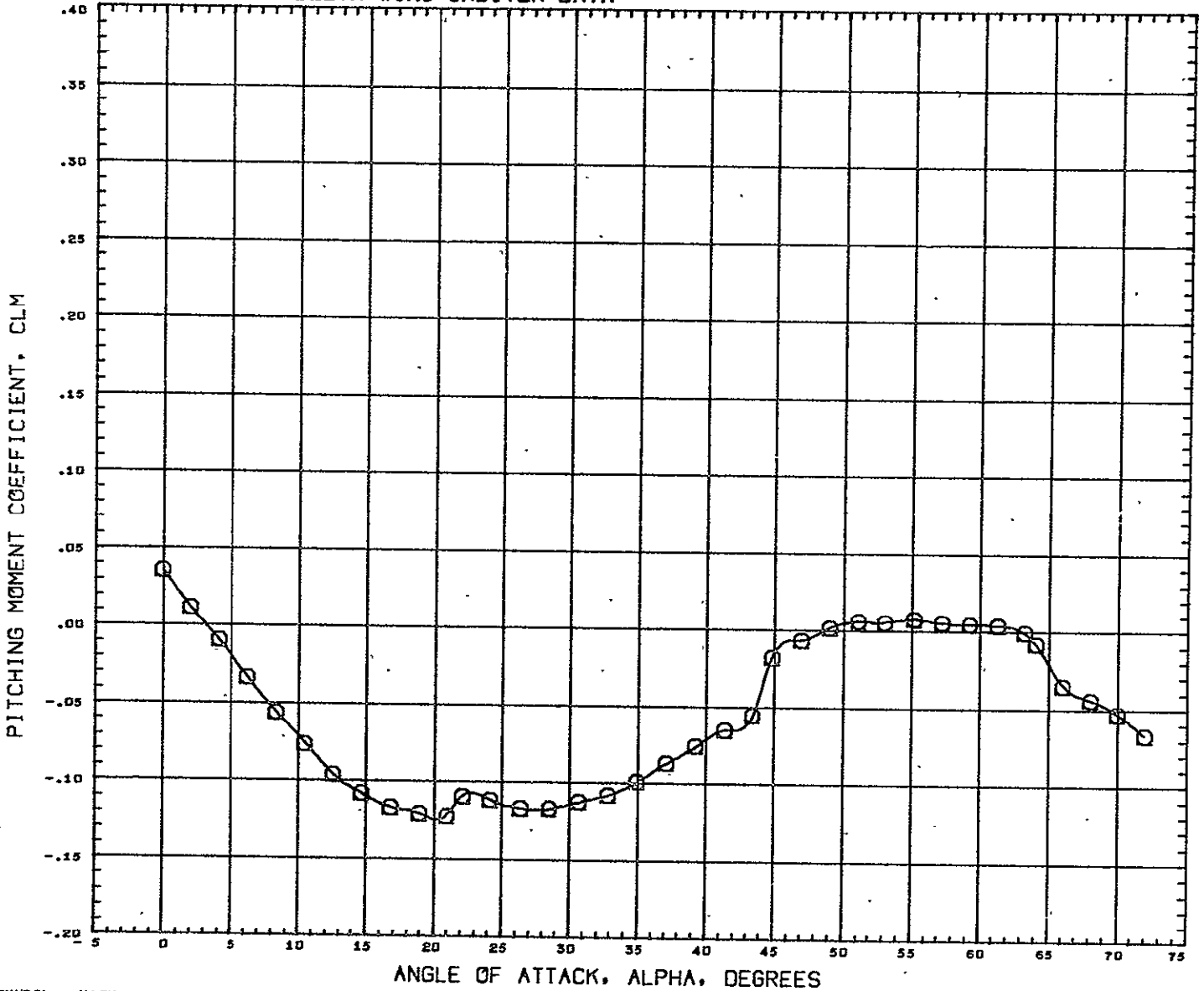

SYMBOL \square MACH 1.201 BETA 0.000 ELVATR 0.000

REFERENCE INFORMATION
 SREF 0.0745 SQ FT
 LREF 2.8742 INCHES
 BREF 4.9798 INCHES
 XMRP 4.9787 INCHES
 YMRP 0.0000 INCHES
 ZMRP 0.4550 INCHES
 SCALE 0.0035 SCALE

DATA HIST. CODE #EV#6

MSFC TWT 477 NR DELTA WING ORBITER DATA

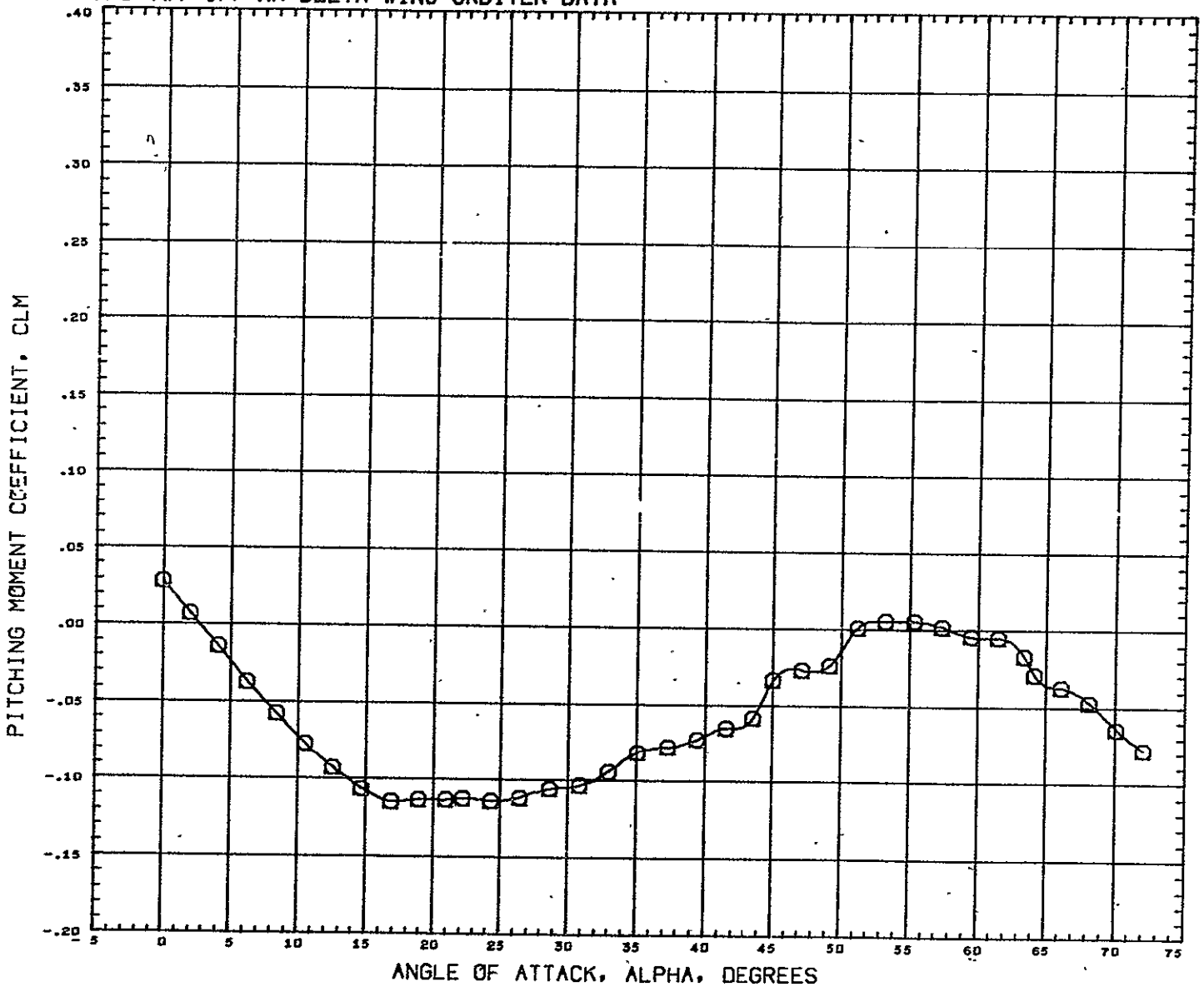

SYMBOL MACH PARAMETRIC VALUES
 O 1.300 BETA 0.000 ELVATR 0.000

REFERENCE INFORMATION
 SREF 0.0745 SQ FT
 LREF 2.8742 INCHES
 BREF 4.9798 INCHES
 XMRP 4.9787 INCHES
 YMRP 0.0000 INCHES
 ZMRP 0.4550 INCHES
 SCALE 0.0035 SCALE

DATA HIST. CODE *EV*6

MSFC TWT 477 NR DELTA WING ORBITER DATA

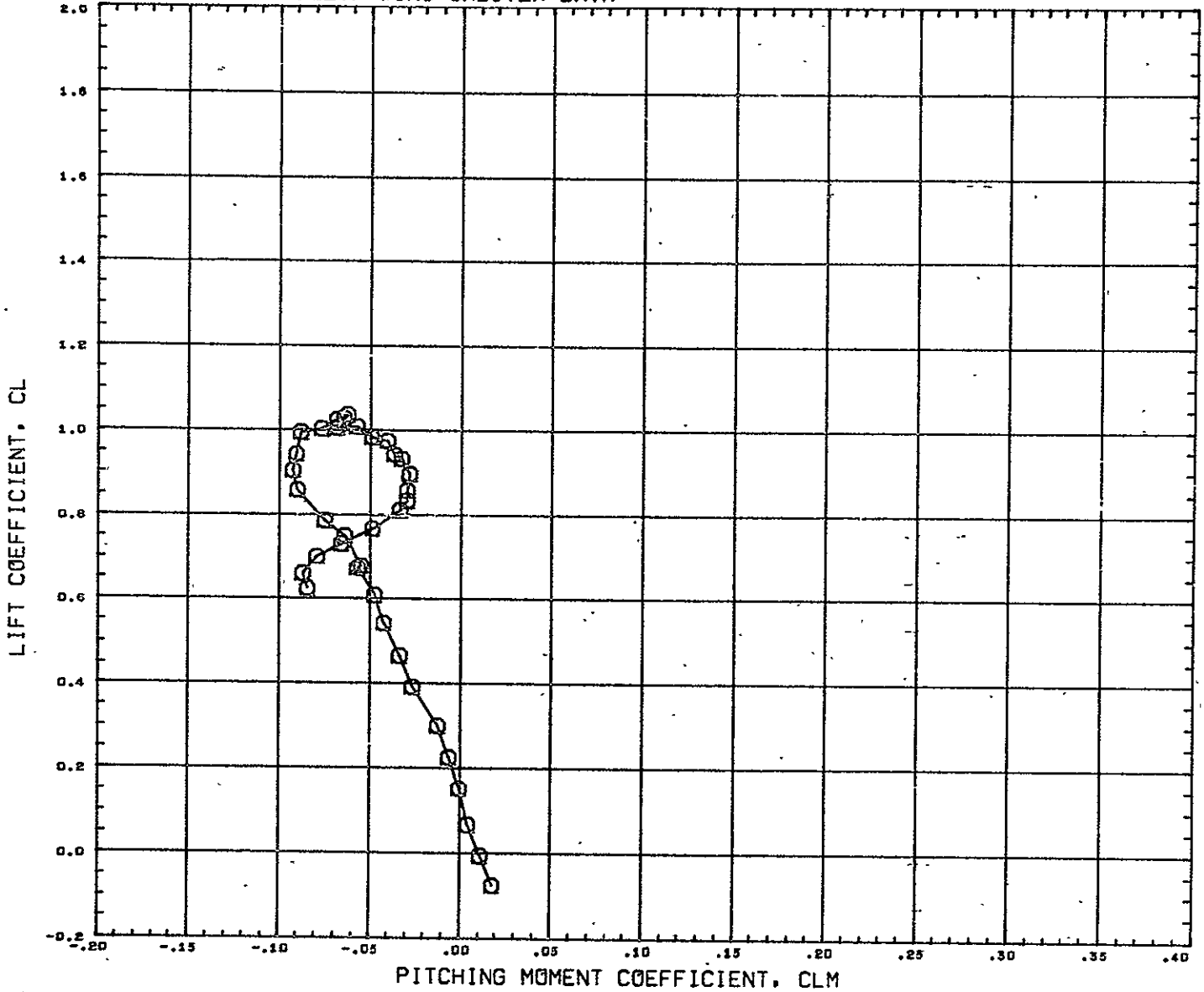

SYMBOL MACH BETA PARAMETRIC VALUES ELVATR 0.000

REFERENCE INFORMATION

SREF	0.0745	SQ FT
LREF	2.8742	INCHES
BREF	4.9798	INCHES
XMRP	4.9787	INCHES
YMRP	0.0000	INCHES
ZMRP	0.4550	INCHES
SCALE	0.0035	SCALE

DATA HIST. CODE #EV#G

MSFC TWT 477 NR DELTA WING ORBITER DATA

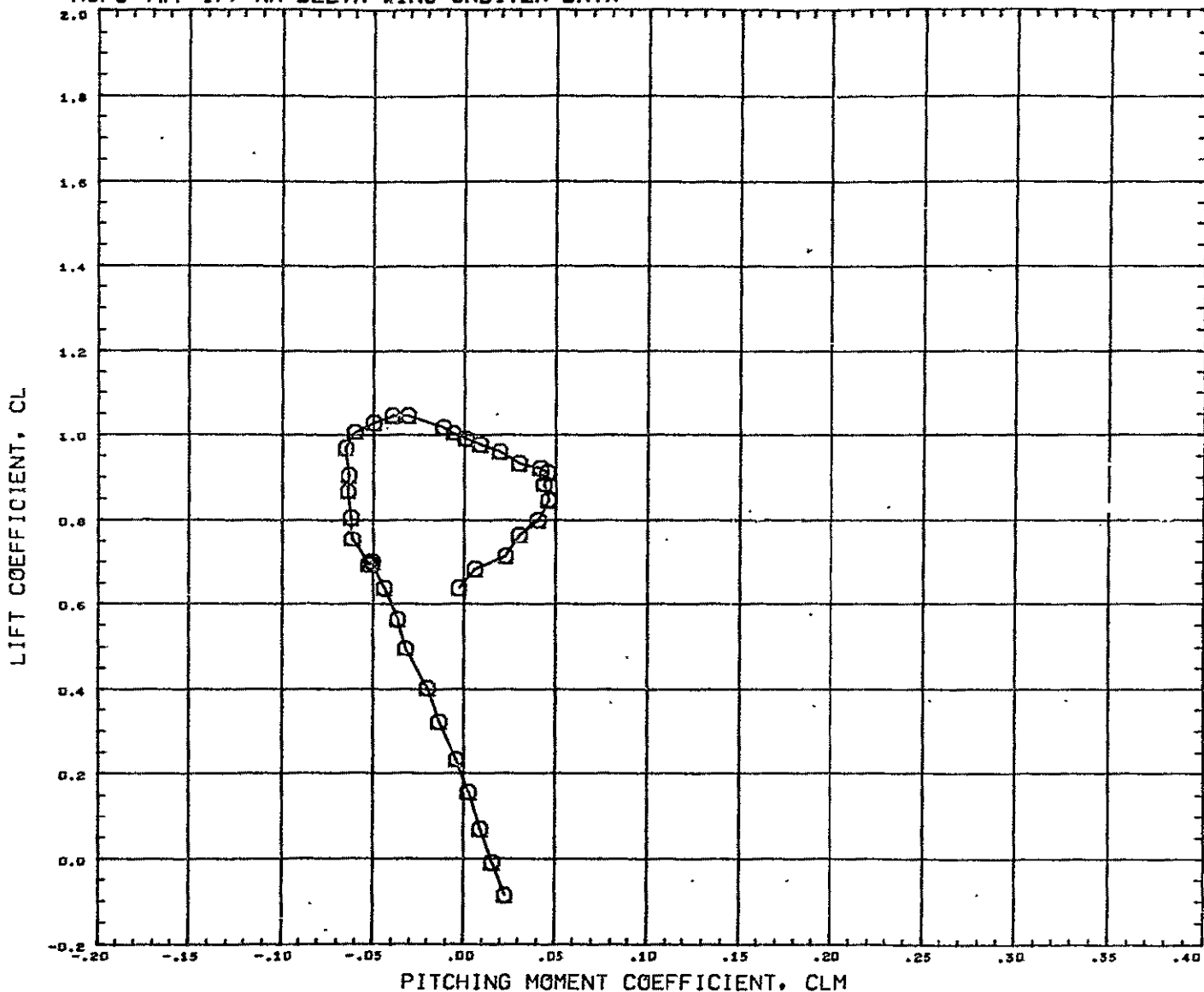

SYMBOL MACH PARAMETRIC VALUES
 Q 0.598 BETA 0.000 ELVATR 0.000

REFERENCE INFORMATION
 SREF 0.0745 SQ FT
 LREF 2.8742 INCHES
 BREF 4.9798 INCHES
 XMRP 4.9787 INCHES
 YMRP 0.0000 INCHES
 ZMRP 0.4550 INCHES
 SCALE 0.0035 SCALE

DATA HIST. CODE #EV*G

MSFC TWT 477 NR DELTA WING ORBITER DATA

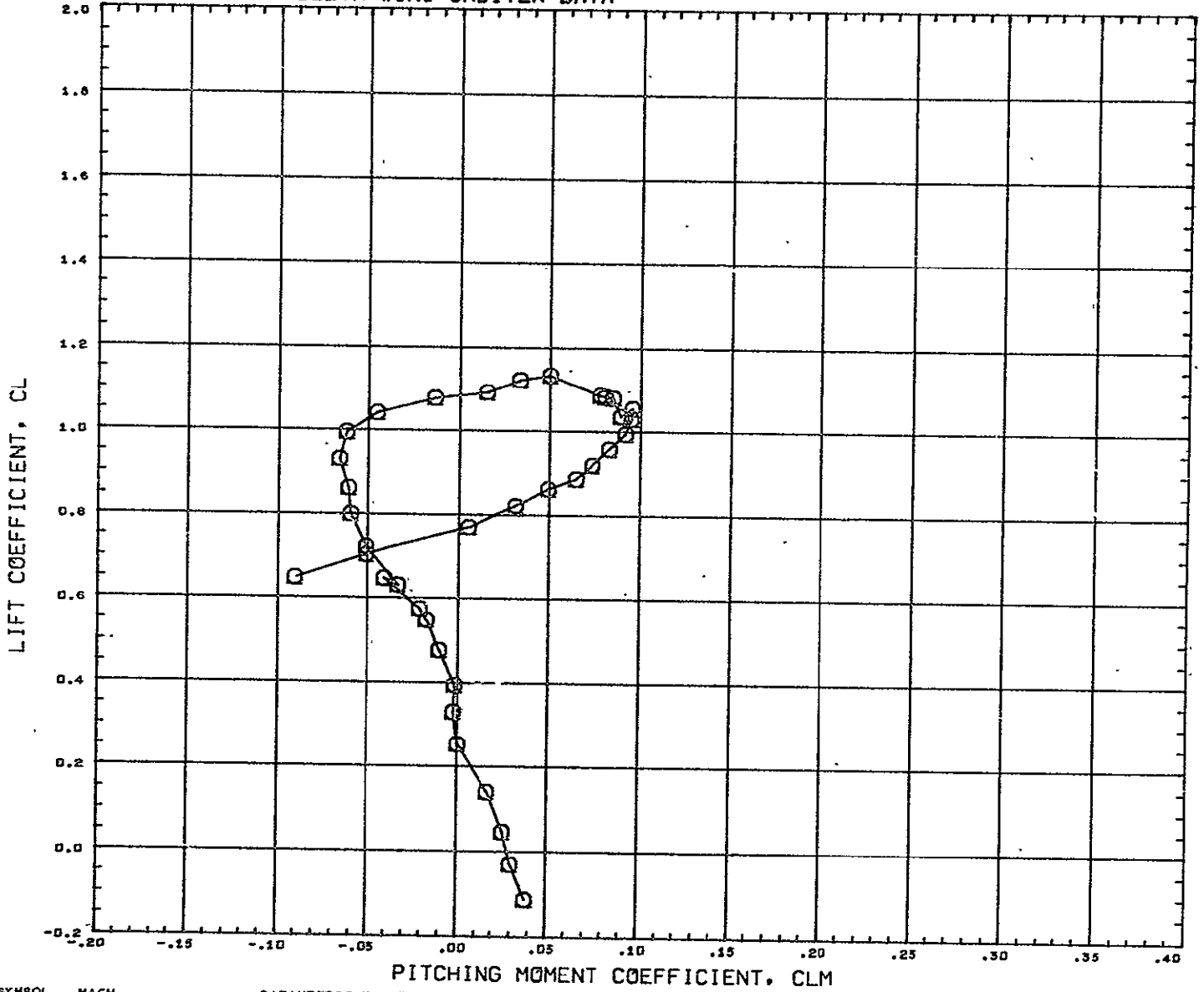

SYMBOL \square MACH 0.698 BETA 0.000 ELVATR 0.000

PARAMETRIC VALUES

REFERENCE INFORMATION

SREF	0.0745	50 FT
LREF	2.8742	INCHES
BREF	4.9798	INCHES
XMRP	4.9787	INCHES
YMRP	0.0000	INCHES
ZMRP	0.4550	INCHES
SCALE	0.0035	SCALE

DATA HIST. CODE #EV*G

MSFC TWT 477 NR DELTA WING ORBITER DATA

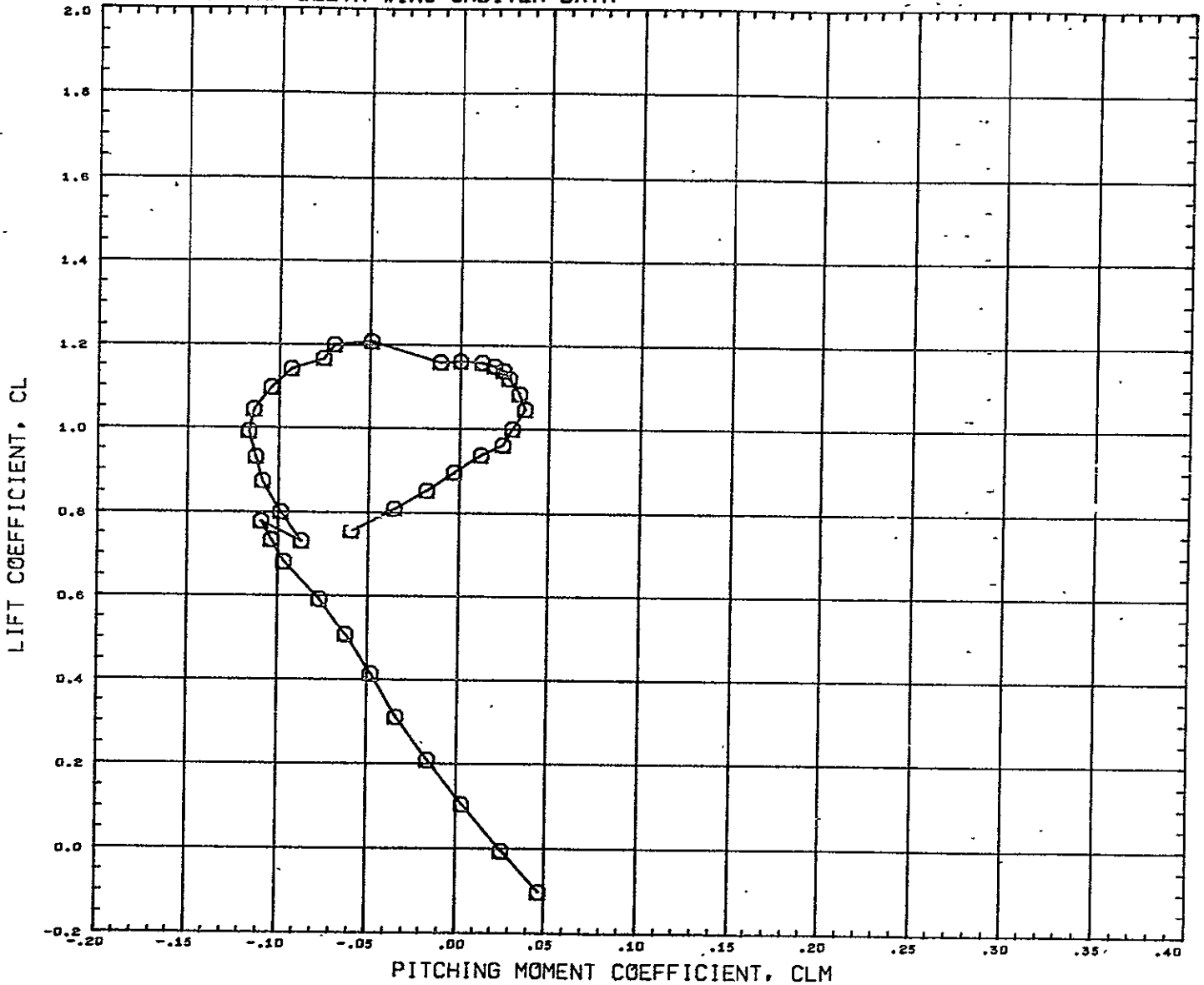

SYMBOL MACH PARAMETRIC VALUES
 □ 0.999 BETA 0.000 ELVATR 0.000

REFERENCE INFORMATION
 SREF -- 0.0745 SQ FT
 LREF 2.8742 INCHES
 BREF 4.9798 INCHES
 XMRP 4.9787 INCHES
 YMRP 0.0000 INCHES
 ZMRP 0.4550 INCHES
 SCALE 0.0035 SCALE

DATA HIST. CODE #EV*G

MSFC TWT 477 NR DELTA WING ORBITER DATA

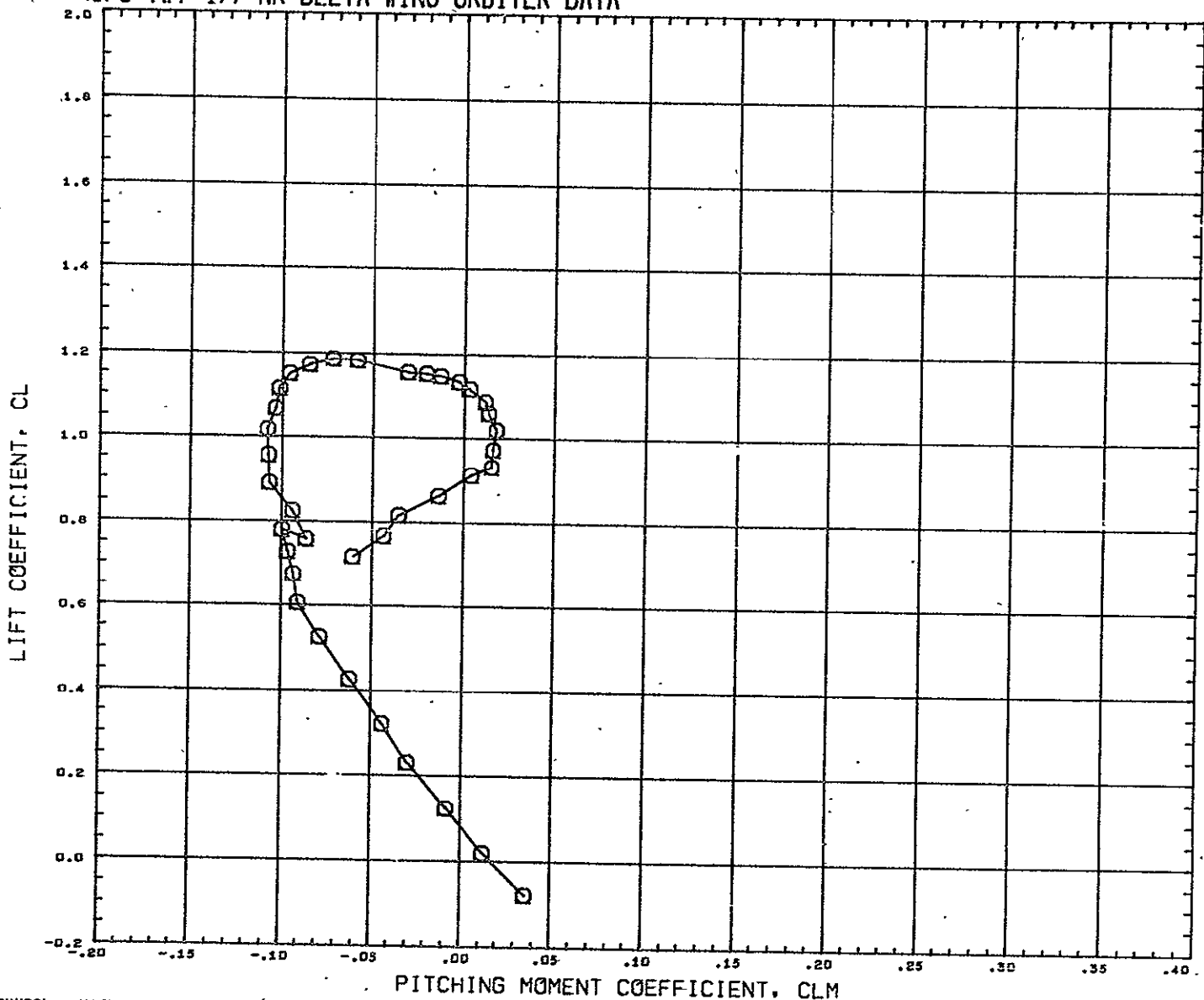

SYMBOL MACH PARAMETRIC VALUES
 □ 1.103 BETA 0.000 ELYATR 0.000

REFERENCE INFORMATION
 SREF 0.0745 SQ FT
 LREF 2.8742 INCHES
 BREF 4.9756 INCHES
 XMRP 4.9767 INCHES
 YMRP 0.0000 INCHES
 ZMRP 0.4550 INCHES
 SCALE 0.0035 SCALE

DATA HIST. CODE #EV#G

MSFC TWT 477 NR DELTA WING ORBITER DATA

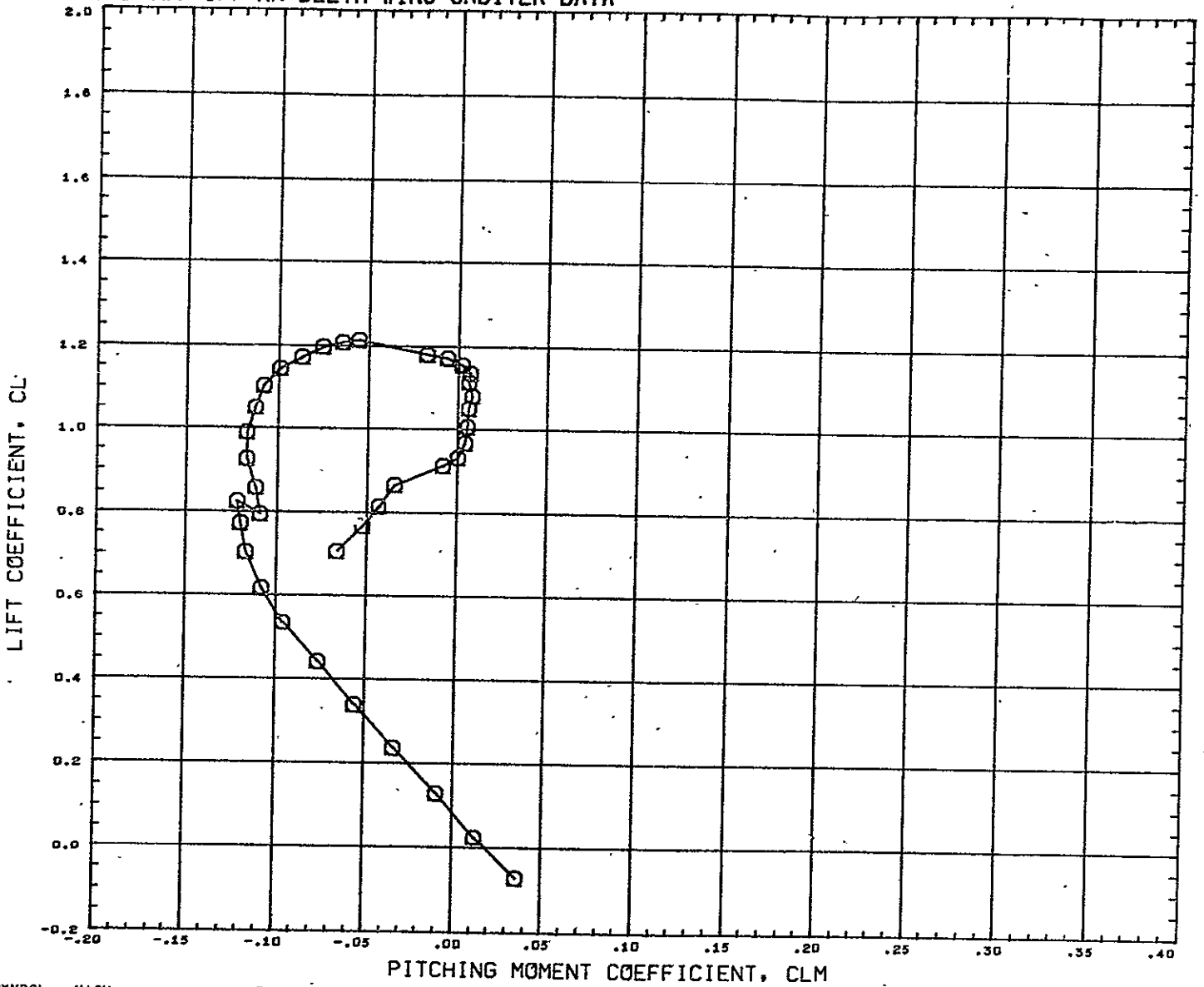

SYMBOL MACH PARAMETRIC VALUES
 ○ 1.201 BETA 0.000 ELVATR 0.000

REFERENCE INFORMATION
 SREF 0.0745 SQ FT
 LREF 2.8742 INCHES
 BREF 4.9798 INCHES
 XMRP 4.9707 INCHES
 YMRP 0.0000 INCHES
 ZMRP 0.4550 INCHES
 SCALE 0.0035 SCALE

DATA HIST. CODE *EV*G

MSFC TWT 477 NR DELTA WING ORBITER DATA

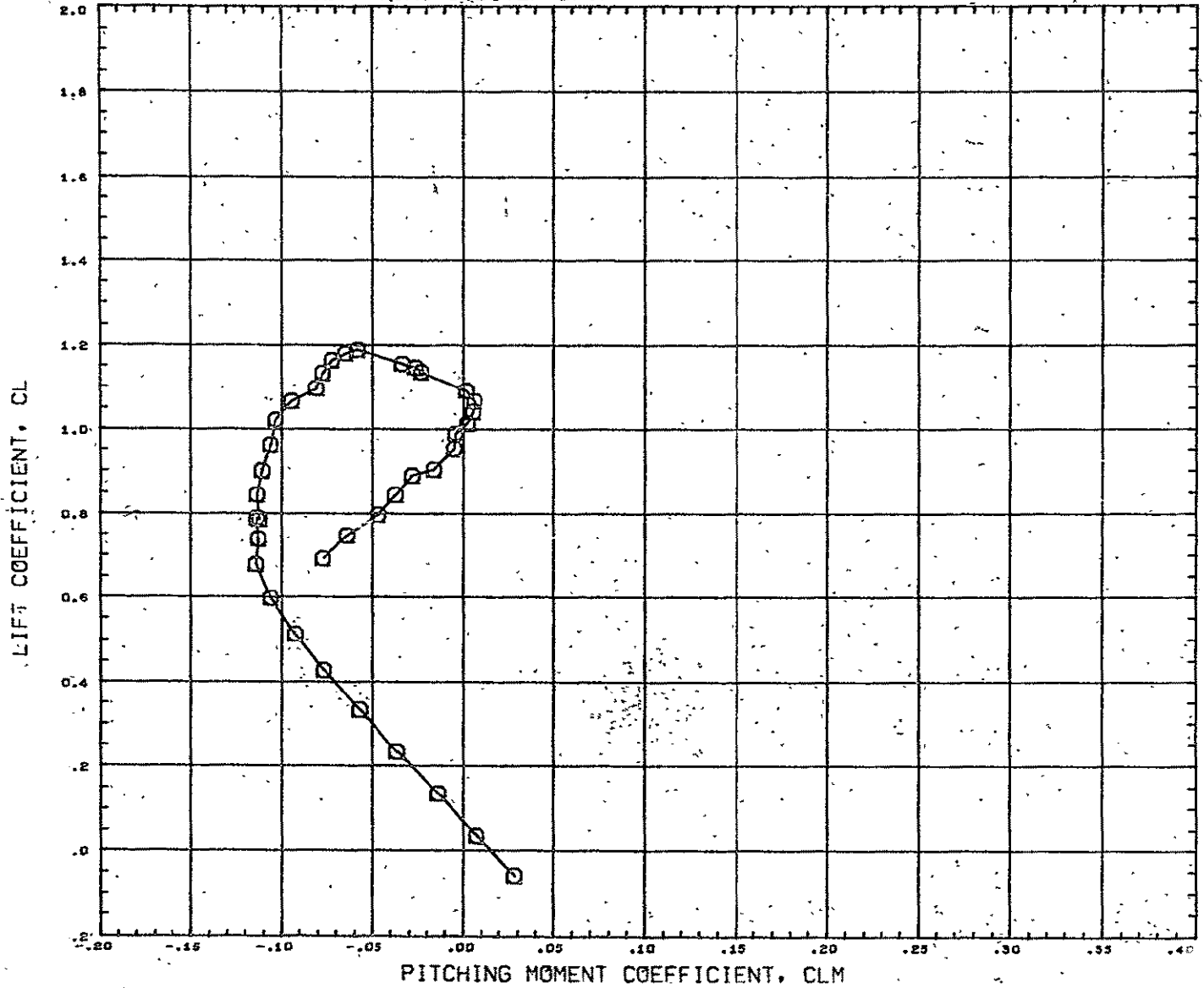

SYMBOL MACH PARAMETRIC VALUES
 ○ 1.300 BETA 0.000 ELVATR 0.000

REFERENCE INFORMATION
 SREF 0.0745 SQ FT
 LREF 2.8742 INCHES
 BREF 4.9798 INCHES
 XMRP 4.9787 INCHES
 YMRP 0.0000 INCHES
 ZMRP 0.4550 INCHES
 SCALE 0.0035 SCALE

DATA HIST. CODE #EV#G.

MSFC TWT 477 NR DELTA WING ORBITER DATA

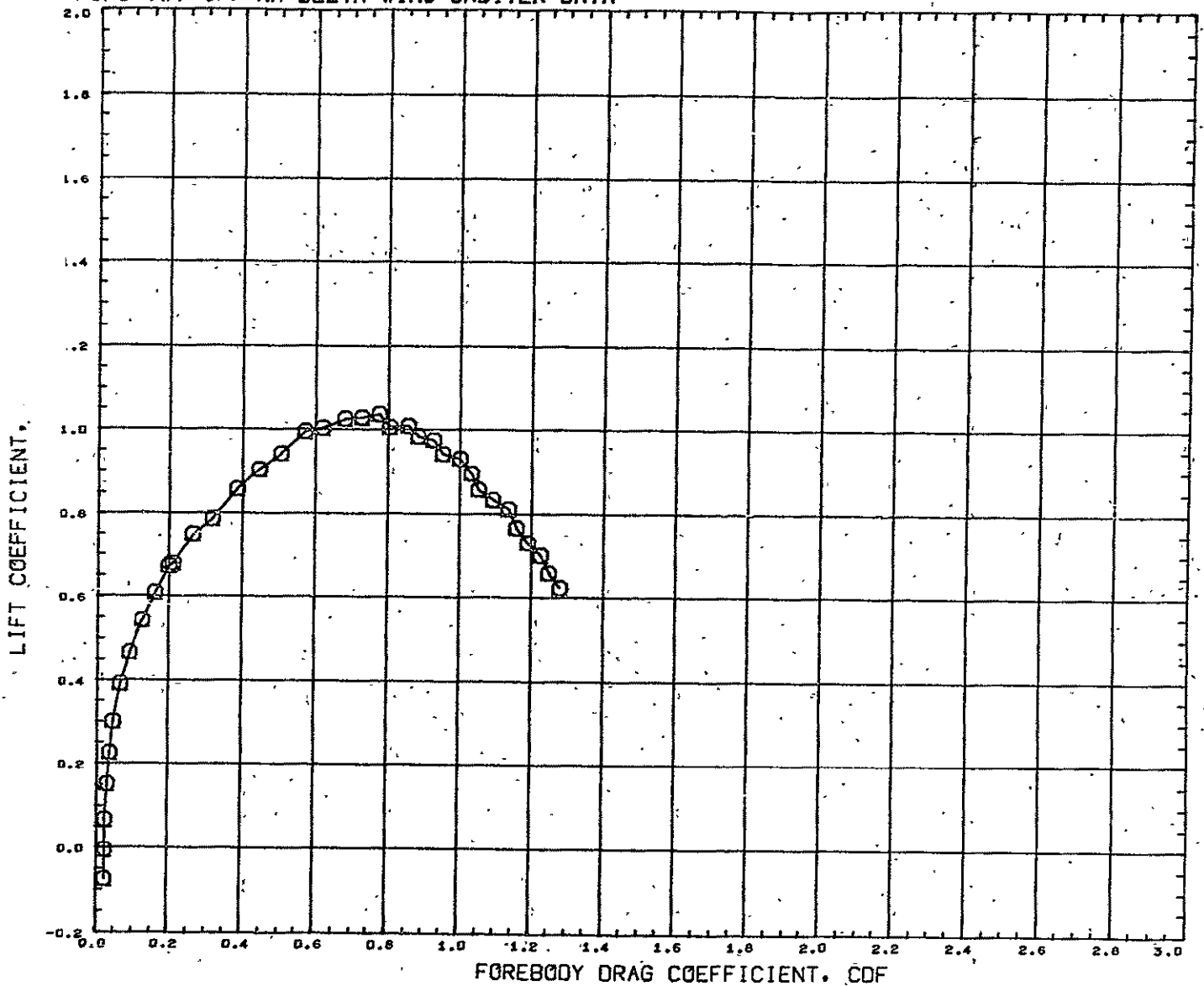

SYMBOL MACH PARAMETRIC VALUES
 ○ 0.400 BETA 0.000 ELVATR 0.000

REFERENCE INFORMATION
 SREF 0.0745 SQ FT
 LREF 2.8742 INCHES
 BREF 4.9798 INCHES
 XMRP 4.9787 INCHES
 YMRP 0.0000 INCHES
 ZMRP 0.4550 INCHES
 SCALE 0.0035 SCALE

DATA HIST. CODE *EV#6

MSFC TWT 477 NR DELTA WING ORBITER DATA

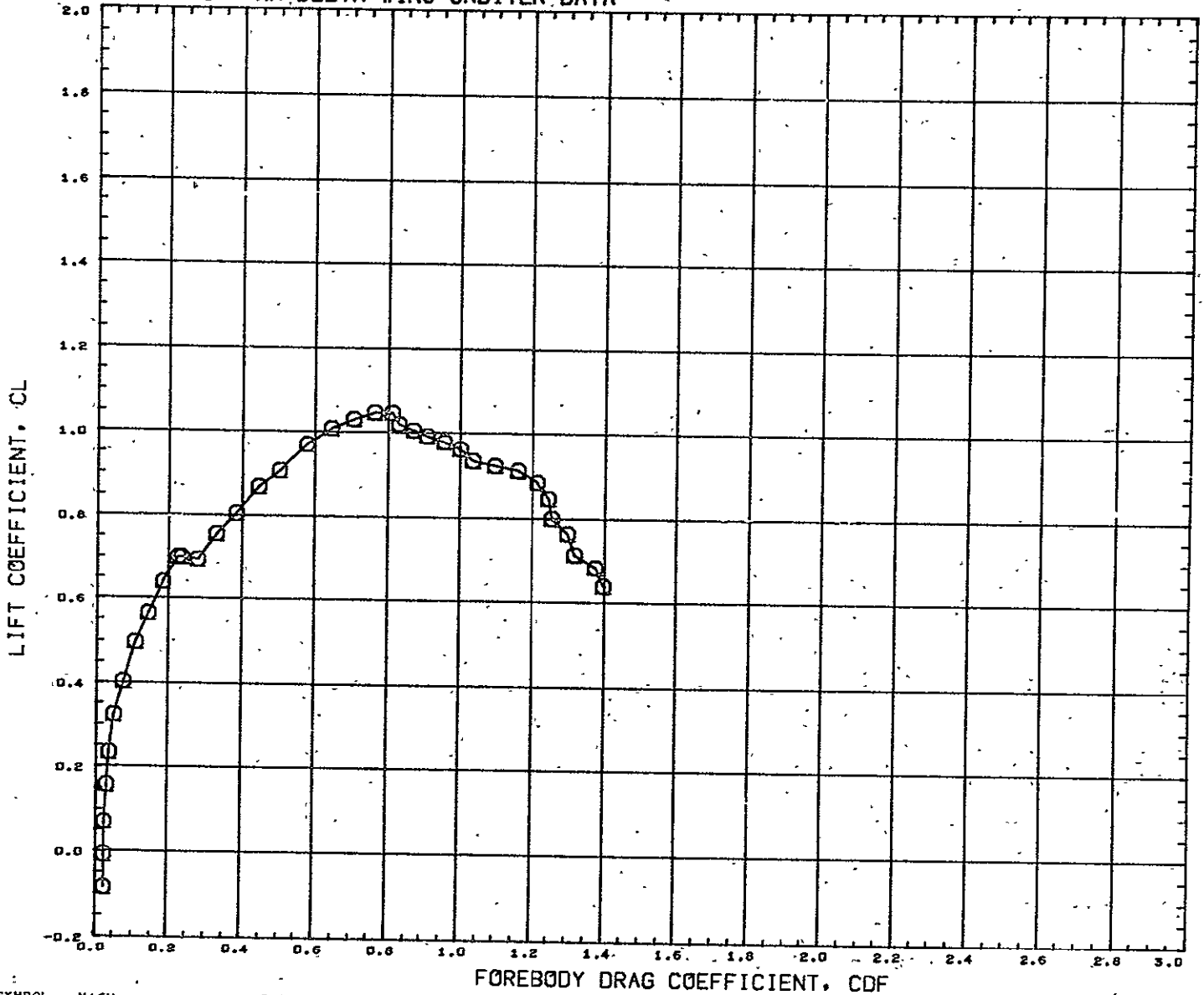

SYMBOL MACH PARAMETRIC VALUES
 ○ 0.598 BETA 0.000 ELVATR 0.000

REFERENCE INFORMATION

SREF	0.0745	SQ FT
LREF	2.8742	INCHES
BREF	4.9798	INCHES
XMRP	4.9787	INCHES
YHRP	0.0000	INCHES
ZHRP	0.4550	INCHES
SCALE	0.0035	SCALE

DATA HIST. CODE #EV#G

MSFC TWT 477 NR DELTA WING ORBITER DATA

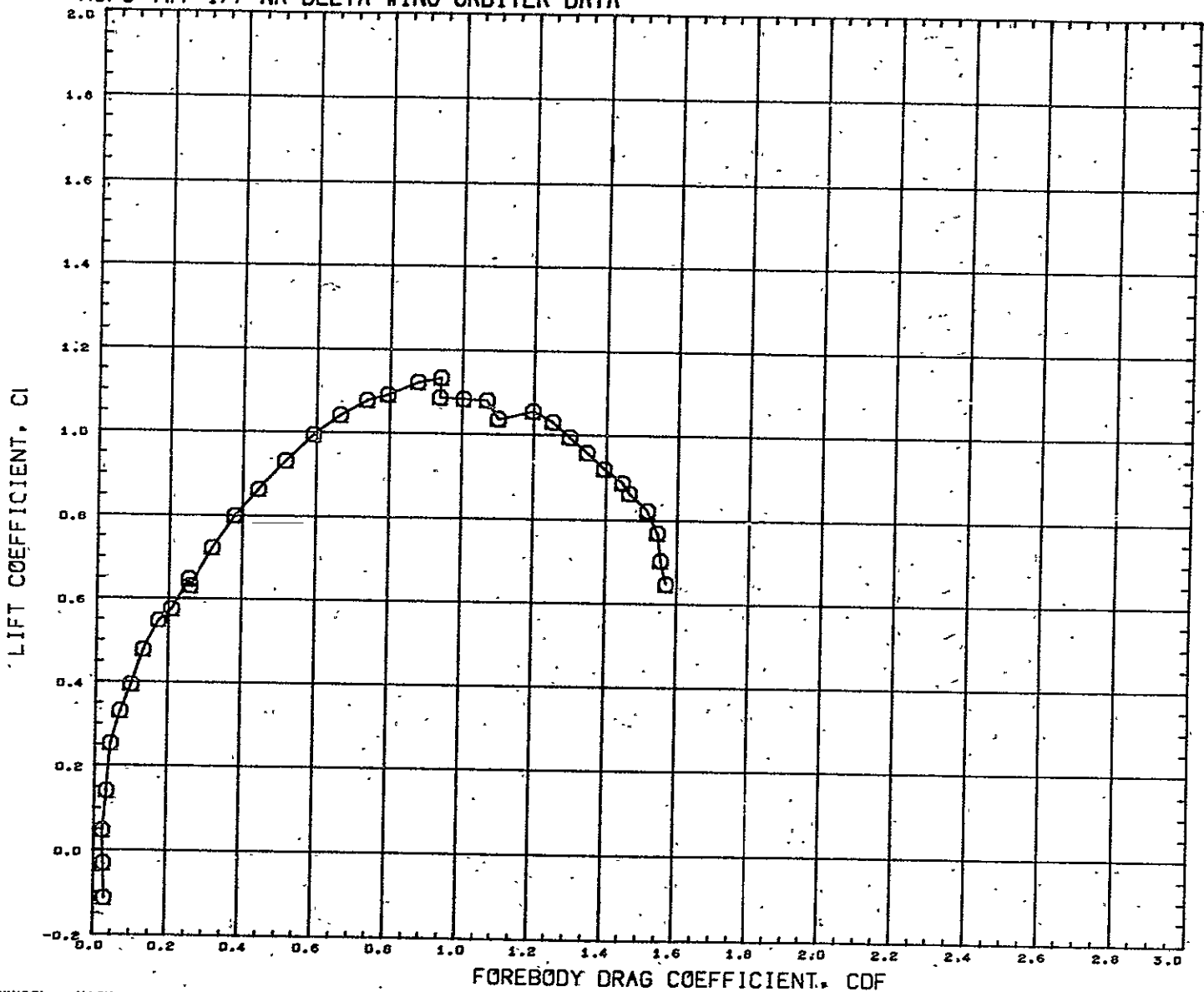

SYMBOL MACH PARAMETRIC VALUES
 O 0.898 BETA 0.000 ELVATR 0.000

REFERENCE INFORMATION
 SREF 0.0745 SQ FT
 LREF 2.8742 INCHES
 BREF 4.9798 INCHES
 XMRP 4.9787 INCHES
 YMRP 0.0000 INCHES
 ZMRP 0.4550 INCHES
 SCALE 0.0035 SCALE

DATA HIST. CODE #EV*G

MSFC TWT 477 NR DELTA WING ORBITER DATA

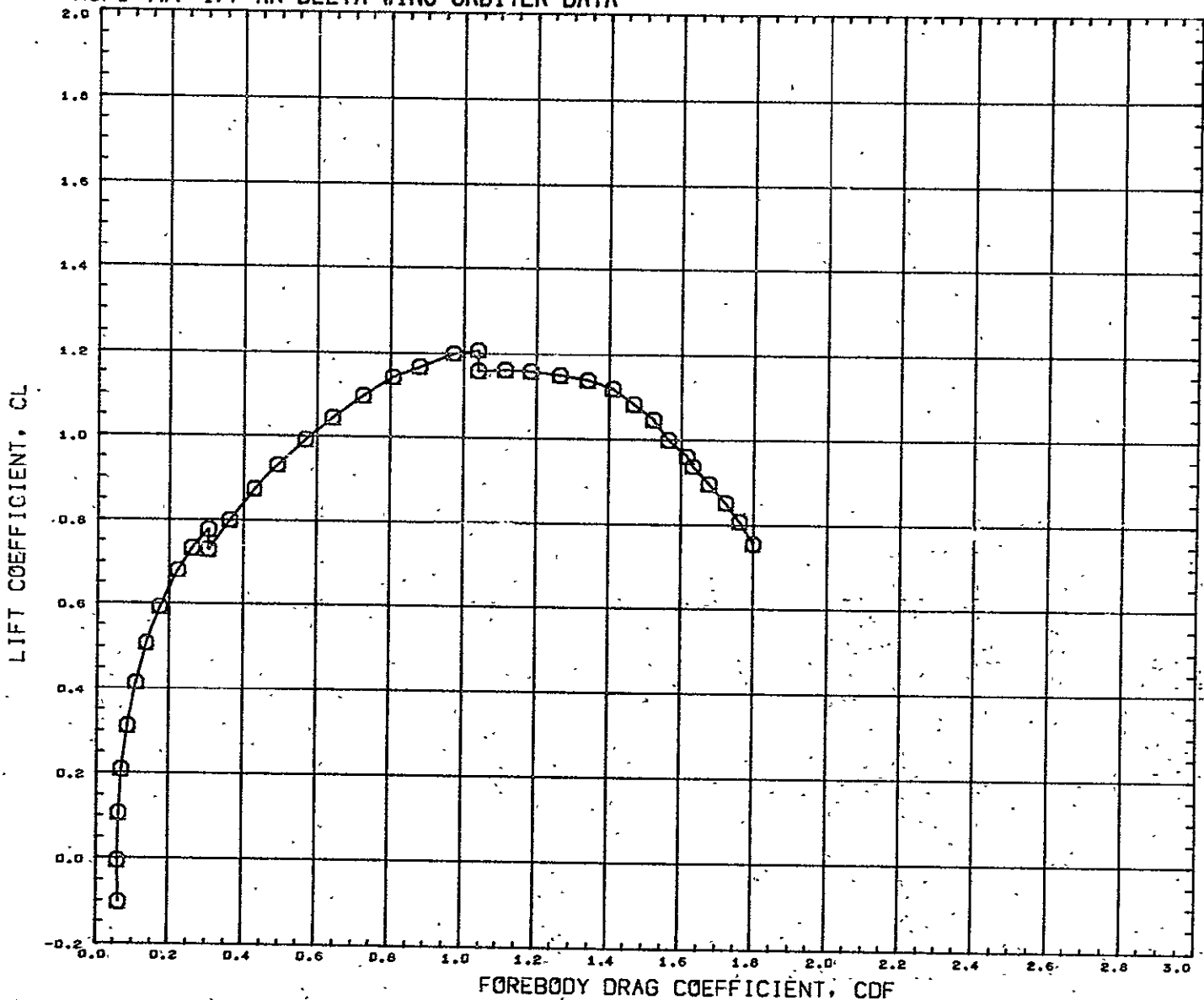

SYMBOL MACH PARAMETRIC VALUES
 ○ 0.999 BETA 0.000 ELVATR 0.000

REFERENCE INFORMATION
 SREF 0.0745 SQ FT
 LREF 2.8742 INCHES
 BREF 4.9798 INCHES
 XMRP 4.9787 INCHES
 YMRP 0.0000 INCHES
 ZMRP 0.4550 INCHES
 SCALE 0.0035 SCALE

DATA HIST: CODE *EV*6

MSFC TWT 477 NR DELTA WING ORBITER DATA

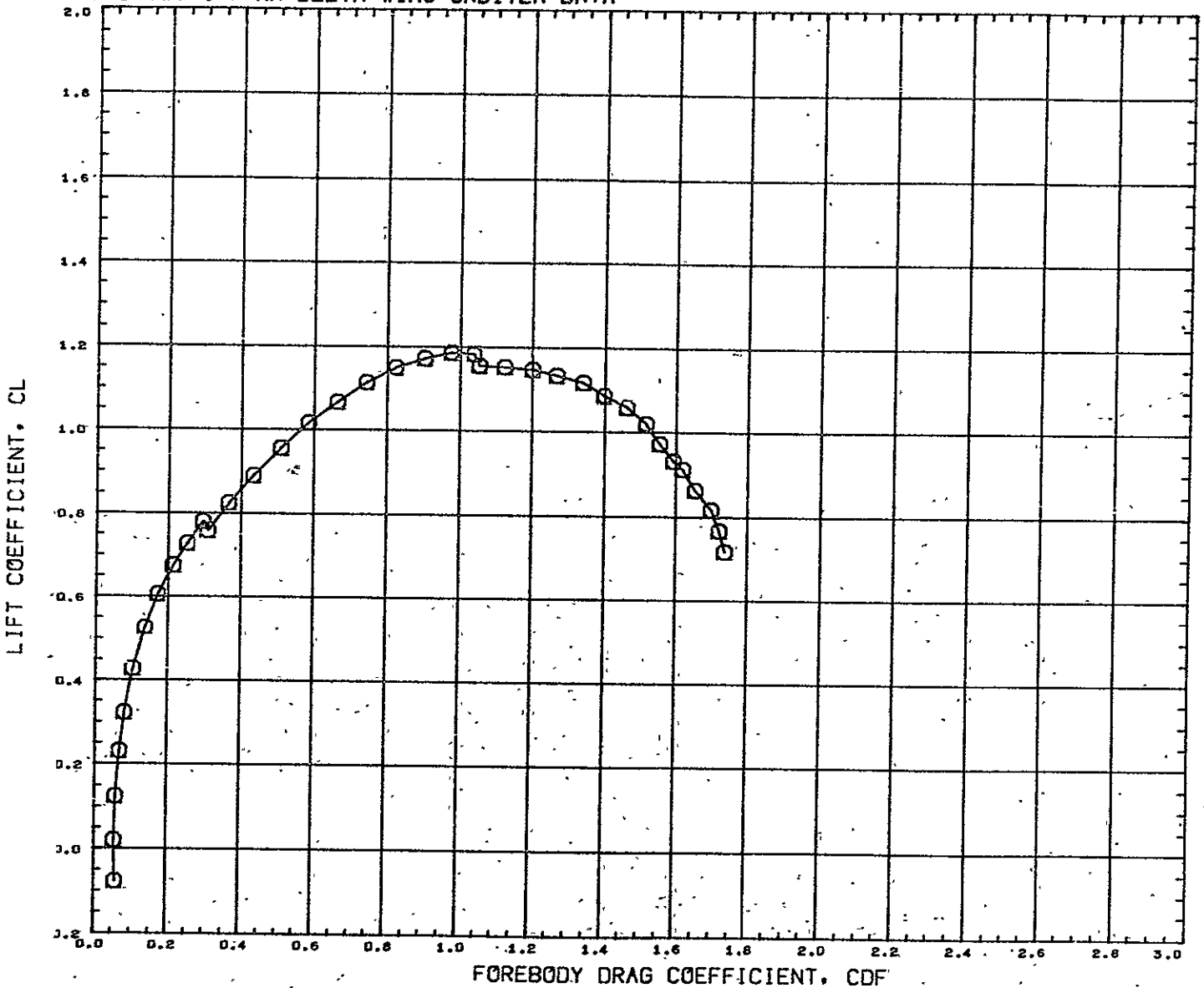

SYMBOL MACH PARAMETRIC VALUES
 O 1.103 BETA 0.000 ELVATR 0.000

REFERENCE INFORMATION
 SREF 0.0745 SQ FT
 LREF 2.8742 INCHES
 BREF 4.9798 INCHES
 XMRP 4.9787 INCHES
 YMRP 0.0000 INCHES
 ZMRP 0.4550 INCHES
 SCALE 0.0035 SCALE

DATA HIST. CODE *EV*

MSFC-TWT 477 NR DELTA WING ORBITER DATA

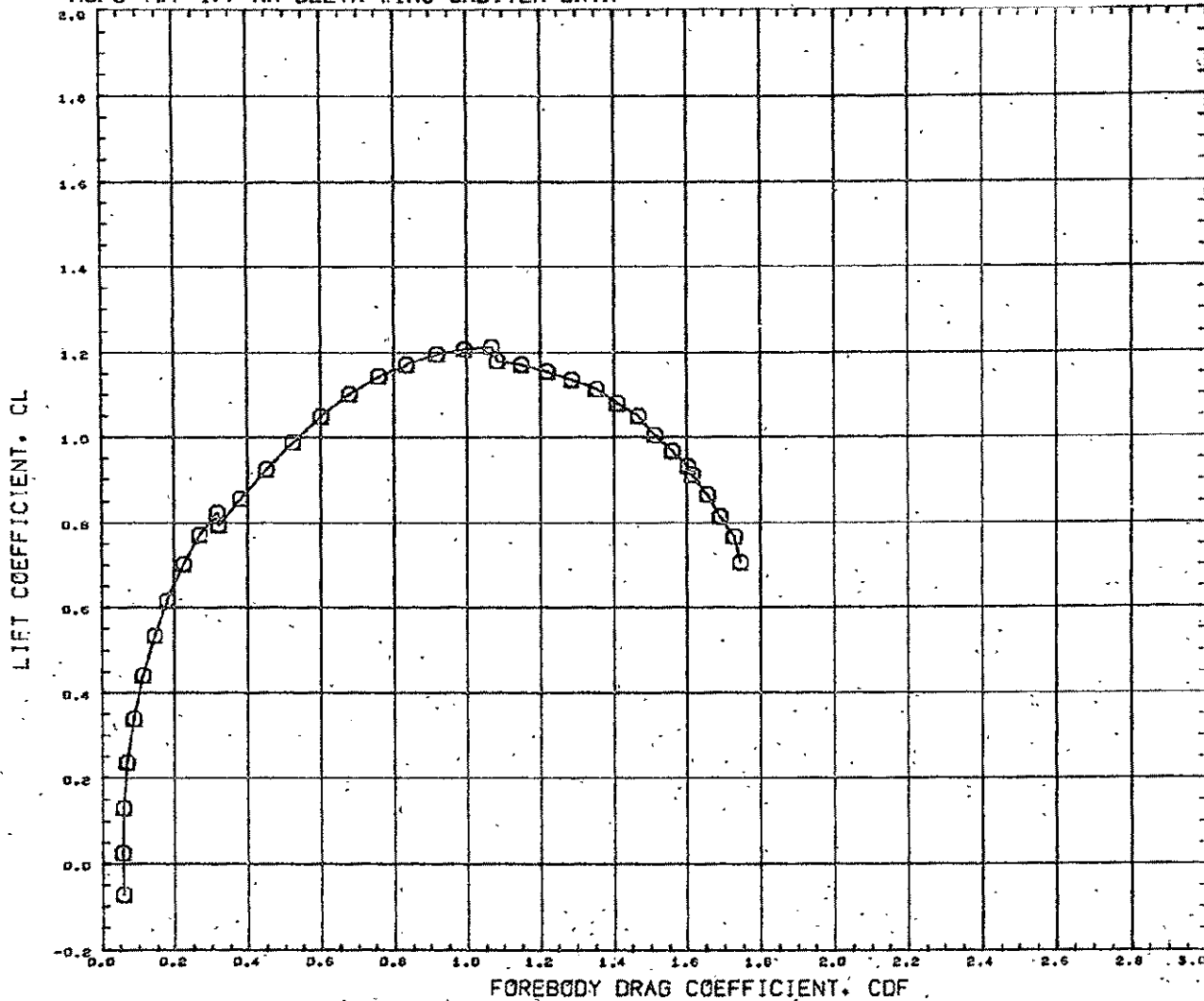

SYMBOL MACH PARAMETRIC VALUES
 □ 1.201 BETA 0.000 ELVATR 0.000

REFERENCE INFORMATION
 SREF 0.0745 SQ-FT
 LREF -2.8742 INCHES
 BREF 4.9798 INCHES
 XMRP 4.9787 INCHES
 YMRP 0.0000 INCHES
 ZMRP 0.4550 INCHES
 SCALE 0.0033 SCALE

DATA HIST. CODE *EV*G.

MSFC TWT 477 NR DELTA WING ORBITER DATA

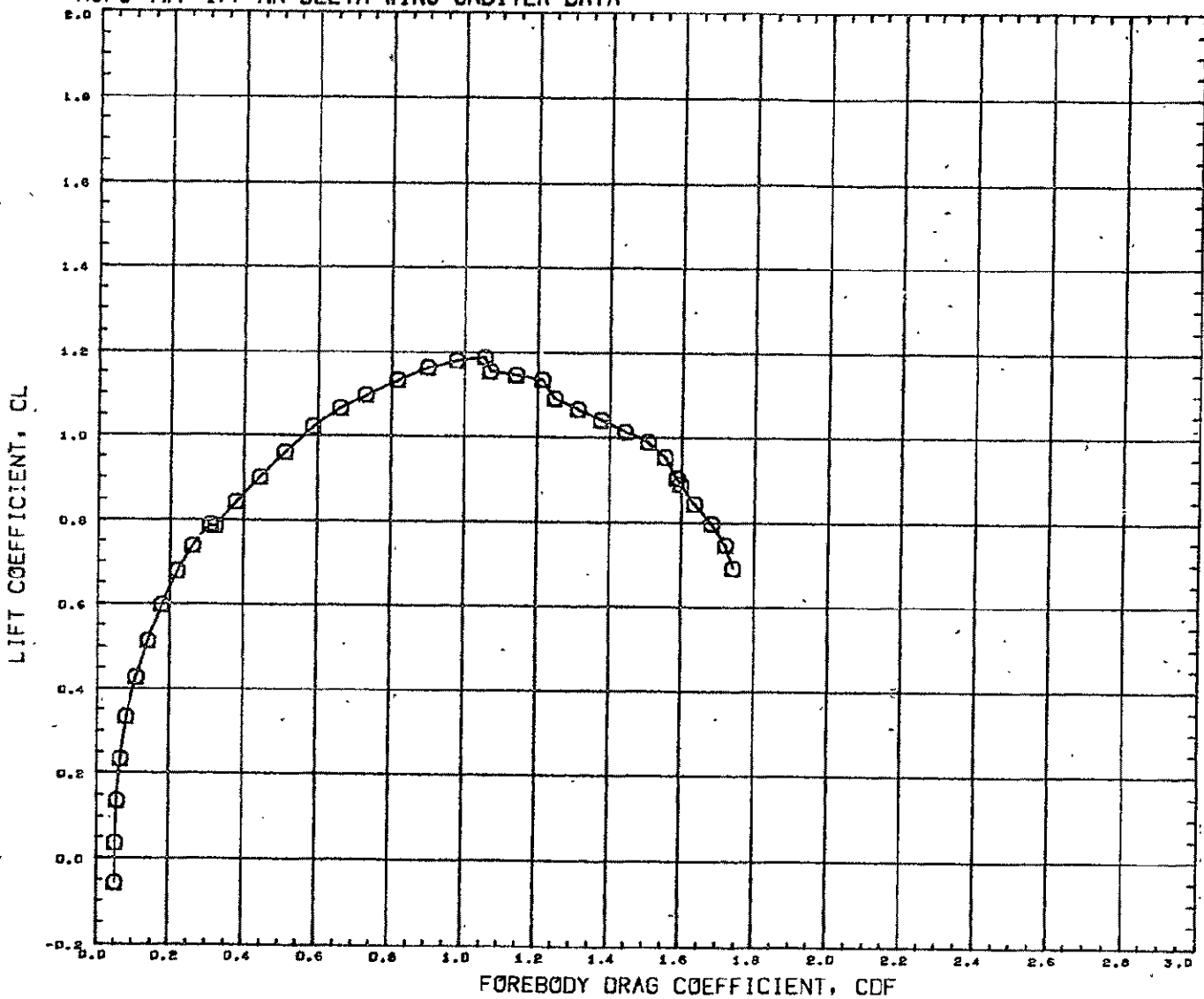

SYMBOL MACH PARAMETRIC VALUES
 ○ 1.300 BETA 0.000 ELVATR 0.000

REFERENCE INFORMATION
 SREF 0.0745 SQ FT
 LREF 2.8742 INCHES
 BREF 4.3798 INCHES
 XMRP 4.3797 INCHES
 YMRP 0.0000 INCHES
 ZMRP 0.4550 INCHES
 SCALE 0.0035 SCALE

DATA HIST. CODE #EV96