

# NASA TECH BRIEF

*Ames Research Center*



NASA Tech Briefs announce new technology derived from the U.S. space program. They are issued to encourage commercial application. Tech Briefs are available on a subscription basis from the National Technical Information Service, Springfield, Virginia 22151. Requests for individual copies or questions relating to the Tech Brief program may be directed to the Technology Utilization Office, NASA, Code KT, Washington, D.C. 20546.

## Twistable Mold for Helicopter Blades

### The problem:

Detailed study of a helicopter rotor system required fabrication of blades composed of sets of aerodynamic shells which have the same airfoil section characteristics but have different distributions. It was necessary to devise a simple, economic system for molding the shells rather than to use laborious machining procedures.

### The solution:

Use a mold which consists of opposing stacks of thin templates held together by long bolts; when the bolts are loosened, the templates can be set at different positions with respect to each other and then locked in place by tightening the bolts.

### How it's done:

A two-piece mold is made of stacked templates essentially as indicated in the diagram. The templates can be machined individually so that each one has the required airfoil section; alternatively, each half of the mold can be milled into a convenient initial shape while the bolts are tight. When rotor blade segments of varying twist are to be produced, the mold bolts are loosened in their slots; the stacks of templates are suitably distorted and then securely locked in place by tightening the bolts. The amount of twist can be adjusted manually or with the aid of a suitable mandrel.

For more precise adjustment of twist, two members are machined to fit into slots in the sides of the templates as shown in the diagram; the members are mounted on supports of differing height to impart the desired twist. If the supports are of equal height, tapered members can be used to impart twist to the stacks of templates.

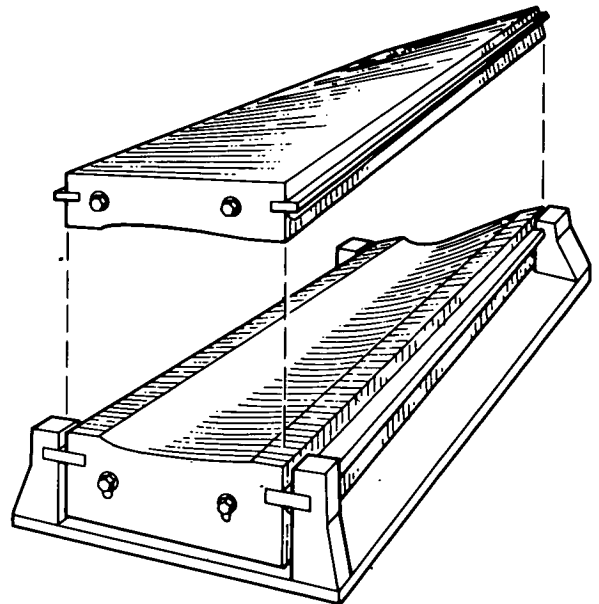

### Note:

No additional documentation is available. Specific questions, however, may be directed to:

Technology Utilization Officer  
Ames Research Center  
Moffett Field, California 94035  
Reference: B72-10432

### Patent status:

NASA has decided not to apply for a patent.

Source: Edmond F. Kiely and  
Edward S. Carter of  
Sikorsky Aircraft Div./United Aircraft Corp.  
under contract to  
Ames Research Center  
(ARC-10682)  
Category 08