

972-11950
NASA CR-62077

VPI-E-71-17
September 1971

Investigation of an Aircraft Trailing Vortex Using a Tuft Grid

**CASE FILE
COPY**

W. H. Mason and J. F. Marchman III

Department of Aerospace Engineering

**This research was supported by the National Aeronautics and Space
Administration, Washington, D. C., under Grant No. NGL 47-004-067.**



**College of Engineering,
Virginia Polytechnic Institute
and State University**

INVESTIGATION OF AN AIRCRAFT TRAILING VORTEX
USING A TUFT GRID

W. H. Mason*

and

J. F. Marchman III**

Department of Aerospace Engineering
College of Engineering
Virginia Polytechnic Institute and State University
Blacksburg, Virginia 24061

* Graduate Research Assistant

** Assistant Professor

ABSTRACT

With the increasing capacity of airport terminal areas, and the use of the new large jet transports, it has become important to understand the turbulent wake created by these aircraft. A study of the trailing vortex of a wing has been made using a tuft grid in the Virginia Tech 6 Foot Wind Tunnel. The study included an investigation of the use of mass injection at the wing tip as a means of destroying the vortex. Test results show that a fully developed, stable, vortex exists at least a distance of thirty chord lengths downstream of the wing, and that the "swirl" of the vortex can be reduced or eliminated by mass injection at the wing tip.

CONTENTS

Introduction	1
Test Apparatus and Procedures	2
Results and Discussion	4
References	7
Special Distribution	8

TABLES

1. Wing Characteristics	9
2. Jet Operating Conditions	9
3. Summary of Data Figures	10

FIGURES

1. Diagrammatic Illustration of a Trailing Vortex	11
2. Wing Installation	12
3. Sketch of Wing and Modification	13
4. Tunnel Schematic	14
5. Tuft Grid Installation	15
6. General Layout of Apparatus	16
7. Position of Vortex in Tunnel	17
8. Tuft Grid Survey, $Q = 1.0'' \text{ H}_2\text{O}$, $Z/C = 3.4, 14.2,$ $20.0, 28.5$	18
9. Tuft Grid Survey, $Q = 2.0'' \text{ H}_2\text{O}$, $Z/C = 3.4, 14.2,$ $20.0, 28.5$	20

10.	Tuft Grid Survey, Q = 5.0" H ₂ O, Z/C = 3.4, 14.2, 20.0, 28.5	22
11.	Tuft Grid Survey, Q = 1.0" H ₂ O, No Blowing, Z/C = 3.4, 12.3, 20.0, 28.5	24
12.	Tuft Grid Survey, Q = 1.0" H ₂ O, Moderate Blowing, Z/C = 3.4, 12.3, 20.0, 28.5	26
13.	Tuft Grid Survey, Q = 1.0" H ₂ O, Full Blowing, Z/C = 3.4, 12.3, 20.0, 28.5	28
14.	Tuft Grid Survey, Q = 2.0" H ₂ O, No Blowing, Z/C = 3.4, 12.3, 20.0, 28.5	30
15.	Tuft Grid Survey, Q = 2.0" H ₂ O, Moderate Blowing, Z/C = 3.4, 12.3, 20.0, 28.5	32
16.	Tuft Grid Survey, Q = 2.0" H ₂ O, Full Blowing, Z/C = 3.4, 12.3, 20.0, 28.5	34
17.	Tuft Grid Survey, Q = 5.0" H ₂ O, No Blowing, Z/C = 3.4, 12.3, 20.0, 28.5	36
18.	Tuft Grid Survey, Q = 5.0" H ₂ O, Moderate Blowing, Z/C = 3.4, 12.3, 20.0, 28.5	38
19.	Tuft Grid Survey, Q = 5.0" H ₂ O, Full Blowing, Z/C = 3.4, 12.3, 20.0, 28.5	40

NOMENCLATURE

z	distance downstream of the 1/4 chord, feet
c	chord, feet
q	dynamic pressure, $1/2\rho V_\infty^2$
C_μ	jet coefficient, $\frac{m_j V_j}{qc^2}$
m_j	jet mass flow rate, slugs/second
S	wing reference area
V_j	jet velocity, feet/second
V_∞	free stream wind velocity
α	wing angle of attack, degrees
ρ	mass density of air, slugs/ft ³
Γ	circulation, ft ³ /sec
Re_C	Reynolds number, $\frac{\rho V_\infty C}{\mu}$
μ	viscosity of air, slugs/ft. sec.
r	distance from center of vortex core, feet
C_L	lift coefficient, $\frac{L}{qS}$
L	lift of wing, lbs.

INTRODUCTION

Aircraft wake turbulence has been a subject of sporadic investigation since the early days of aviation. Early interest centered around the effect of the wing downwash on the tail and control surfaces of the aircraft. The long term effects of the rolled up wake or tip vortex (once known as "prop-wash") on trailing aircraft were given only occasional study. However, the recent introduction of the very large transport of the C-5, B-747 type with its large resulting wake has brought the problem of the trailing vortex into sharp focus. Recent FAA studies have indicated the importance of the tip vortex in determining aircraft separation criteria and terminal operation standards (Ref. 1). This and other studies have led to increased publicity and pilot education efforts regarding the behavior and dangers of the trailing vortex. Numerous newspaper and magazine articles as well as new FAA Advisory Circulars (Ref. 2) have warned the pilot and the public of the problem. Meanwhile, increased theoretical and experimental research efforts are being employed to better understand and, hopefully, reduce the problem.

The trailing vortex as pictured in Figure 1, is a result of the circulatory lifting flow on the aircraft wing. The wing's lift can be attributed to the circulation about the wing as

$$L = \rho V_{\infty} \Gamma.$$

According to the well known Prandtl "horseshoe" vortex model this circulation (Γ) must bend at right angles at the wing tips to form the trailing vortices. Theoretically these vortices extend to infinity but they are known to break up or dissipate in reality in a number of ways which are, as yet, poorly understood.

As is seen in the previous equation, the greater the aircraft lift, the higher the circulation in the trailing vortex, resulting in the problems brought to the fore by the "Jumbo Jets." The same problems exist with smaller aircraft in varying degrees. Although smaller aircraft may have smaller vortices, the velocities may be very large, producing as much danger to the trailing aircraft as the wake of a larger aircraft.

Various proposals have recently been put forth to help reduce the vortex problem. One of the more popular concepts now is that which uses mass injection or blowing into the vortex as the wake begins to roll up. Although most investigations of this concept are still in the early stages, there are indications that such mass injection either diffuses the vortex or results in earlier breakup. Either effect would be welcome to the pilot of an aircraft which encounters a trailing vortex. Further investigation is needed to define the governing parameters and mechanisms involved in mass injection into the vortex.

One of the simplest ways to study a wing tip vortex and its development is to use a tuft grid (a wide mesh screen with wool tufts at the wire intersections). This method was employed in early NACA studies successfully as indicated in Reference 3. This early work performed at the Langley Research Center of NASA in the Langley Stability Tunnel. The Stability Tunnel and its associated equipment were moved to Virginia Tech in 1958, where it is now known as the 6-Foot Wind Tunnel. It is therefore reasonable to expect that wool tuft tests using the same tuft screen and wind tunnel employed in Reference 3 to study the trailing vortex should produce excellent results.

The present trailing vortex investigation is part of a larger overall study of ground wind turbulence sponsored by NASA grant NGL 47-004-067 and directed by NASA, Wallops Station. The purpose of the trailing vortex investigation is to learn more about the structure of the trailing vortex to facilitate its detection by instrumentation designed for turbulence detection in ground winds. To carry out this study several methods are being employed. The initial tuft grid study, reported here, is being used to give preliminary data regarding the overall nature and behavior of the vortex in the wind tunnel. Following this a study of the detailed structure of the vortex is being conducted using specially constructed pressure and velocity probes. The vortex will be mapped for pressure, velocity, and turbulence patterns at various distances downstream of the wing.

TEST APPARATUS AND PROCEDURES

The test procedure for the tuft grid study of the vortex is a simple one, using a wing mounted in the wind tunnel to produce the trailing vortex, a tuft grid behind the wing and a camera mounted downstream to photograph the tuft pattern resulting from the flow. The technique and apparatus employed is very similar to that described in Reference 3. In this study the primary objective was to examine the vortex development far downstream of the wing, whereas earlier tuft studies (Reference 3) were concerned with rear wing wake roll-up. Hence, in the present case the wing was mounted near the front of the 28 foot long test section of the Virginia Tech 6-Foot Wind Tunnel to allow the longest possible wake development in the test section length.

An NACA 0012 straight, square-tipped wing was mounted vertically from the tunnel roof one foot from the front of the test section. The mounting allowed the wing to be set at variable angles of attack and placed the free wing tip near the center of the wind tunnel. The mounted wing is shown in Figure 2. This mounting allowed tuft grid placement from three to thirty chord lengths behind the wing before the flow reached the diffuser section of the tunnel. Complete specifications of the wing are given in Table 1. The present tests

were made using a wing angle of attack of approximately 7-1/2 degrees to produce a highly visible vortex flow.

In order to include mass injection at the wing tip, the wing model was modified to carry a copper tube 1/4 inch diameter along the leading edge and tip as shown in Figure 3. Mass injection was obtained by metering air from an available high pressure supply using a simple orifice metering system.

The Virginia Tech 6-Foot Subsonic Wind Tunnel is a continuous, single return, closed test section tunnel with a 6 x 6 foot square test section 28 feet in length. The tunnel turbulence level is low due to seven anti-turbulence screens upstream of the test section. The complete tunnel schematic is shown in Figure 4. The tuft grid used in the tests was constructed at Langley Research Center, and is described following Reference 3:

"The tuft grid employed in this investigation consisted essentially of a rectangular grid of fine wires (0.012 in. diameter) at 1-inch mesh supported at the periphery by a tubular framework with 3-inch woolen tufts attached at the intersection of the wires. The tufted area of the grid was 50 inches wide and 26 inches high. A preloading system consisting of a spring mounted between one end of each wire and the frame was used to maintain a 1.5 pound tension in each wire. Each intersection of a vertical and horizontal wire was soldered so that relative movement between wires would be eliminated.

"The tufts were of 4-ply-wool baby yarn and were attached to the grid with strong thread. A small loop of thread was provided at the attaching point in order to permit the tuft to move freely in all directions. The downstream end of each tuft was tied with thread to prevent the strands of wool from unraveling.

"A truss-like structure was welded to each of the rectangular frame members to provide a fairly rigid frame. The frame and truss like structure were fashioned from thin-wall streamline tubing having a 0.75 inch chord." Mounting brackets were attached on each side of the grid, and the tuft grid was mounted on rails on the side of the tunnel for positioning every foot along the test section. The basic set-up is shown in Figure 5.

The photographs were made using a 35 mm camera mounted in two positions in the tunnel. The general layout of the apparatus is shown in Figure 6. In the rear camera position a 500 mm lens was used, with six 500 watt photo spots and two 750 watt photo spots, mounted at the rear of the test section. In the forward camera position a 135 mm lens was used with six 250 watt photo flood lights. The shutter was operated remotely from the wind tunnel control area.

The test program consisted of two series of pictures. The first series was of the clean wing configuration with the grid at fourteen positions, with the tunnel at dynamic pressures of 1, 2, and 5 inches of water at each grid position. The second series of pictures was made on the modified wing configuration with the grid in four positions along the tunnel. At each position the tunnel was operated at dynamic pressures of 1, 2, and 5 inches of water, and for each dynamic pressure the mass injection was set at 0.0, 0.000213, and .000375 slugs per second. The dynamic pressures of 1, 2, and 5 inches of water correspond to sea level equivalent speeds of 66.1, 93.5, and 147.9 feet per second.

RESULTS AND DISCUSSION

All of the photographs of the wing without mass injection show a distinct trailing vortex. Representative photos are presented for four positions behind the wing, $z/c = 3.4, 14.2, 20.0, 28.5$, and dynamic pressures of 1, 2, and 5 inches of water. Table III summarizes the photos presented in Figures 8 through 19. Figures 8, 9, and 10 are results for the clean wing configuration, and show the vortex as it moves down the tunnel. At each dynamic pressure the vortex is seen to be well developed by the first tuft grid position ($z/c = 3.4$). The blurred tufts in the photos indicate the vortex core region to be fully turbulent. Surrounding this turbulent region, it is seen that the tuft grid is disturbed in a steady manner that suggests the $1/r$ type flowfield of the potential vortex. The figures indicate that the vortex size, or at least that of the turbulent portion of the vortex, increases slightly with tunnel speed. The vortex seems to be essentially constant in size and magnitude of disturbance as it moves down the tunnel. At the highest tunnel speed vibration of the camera and tuft board prohibit a detailed study of the pictures but still the vortex is clearly visible.

The tip vortex position has been read from the photos, and is shown in Figure 7. Also shown is the theory of Sprieter and Sacks, (Reference 4), for an unconfined vortex. As has been demonstrated by Hackett and Evans (Reference 5) numerically, the wind tunnel walls influence the position of the vortex considerably. The position of the vortex is also in agreement with the wind tunnel work of Gasperek (Reference 6). It can be seen that after traveling a few chord lengths, the vortex path is parallel to the freestream velocity. This is significant because the angle of the vortex path with the freestream can be neglected except in the region near the wing, thus simplifying the problems of an investigator wishing to study the vortex with a probe.

In the mass injection case the vortex is dramatically changed. Injection apparently decreases the turbulence and swirl in the vortex core. The results are shown in Figures 11 through 19, and show that

at low freestream velocities and high mass flows the turbulence in the vortex is decreased near the wing and is apparently gone at the stations farther downstream. The swirl is reduced greatly, and there are only traces of the potential vortex. The effect is not as pronounced as tunnel velocities increase, very probably due to the use of two mass flow rates as the test parameters, and the resulting decrease of the jet coefficient with increasing tunnel velocity. The injection does affect the position of the vortex in the tunnel at the farther downstream stations. This effect does not appear uniform, and in view of the previous discussion on wall interference effects it is difficult to assess the injection effects on vortex position. It is well known however, that prior to vortex decay, vortices often show an instability resulting in a sinusoidal motion of the vortex. It is possible that this type of behavior may be responsible for the non-uniform vortex movement.

From this study it is concluded that a stable, well developed vortex exists over a range from three to thirty chord lengths downstream of the wing. The position of the vortex is strongly influenced by the tunnel walls, as was shown by comparison with the theories of Sprieter and Sacks (Reference 4), and Hackett and Evans (Reference 5).

Mass injection in the freestream direction at the tip, has been shown to be an effective method of controlling the vortex, with the core becoming non-turbulent and the swirl velocity decreasing with increasing mass injection. As yet no conclusion can be reached concerning the practicality of the amounts of injection required for vortex control on present generation aircraft. It is interesting to note that these conclusions are very similar to the conclusions arrived at from a theoretical standpoint in studies made by Rinehart (Reference 7).

In view of the results of this study, and the large demand for experimental investigations in aircraft trailing vortices, some suggestions as to the directions future studies take can be made. Because of the well developed, stable vortex, with a path parallel to the freestream velocity, this wind tunnel set-up appears to provide a good opportunity to investigate the vortex far downstream by use of a traversing probe. Initially this probe will be a small yawhead pressure probe, mounted so that it can be aligned with the local velocity direction. This study would yield mean flow information and allow a static probe to traverse the vortex with the proper alignment at each point. Hot-wire probes can then be used to study the turbulent quantities in the vortex. Since aircraft never operate in the ideal conditions of a low turbulence wind tunnel, it is important to investigate the effects of controlled ambient turbulence, and shear flows on the vortex. True conditions around airports include landing in the atmospheric boundary layer, which is almost always a shear flow with some degree of ambient turbulence.

Further studies on mass injection should be carried out, with one study being a tuft study of the vortex at different freestream velocities, and holding the jet coefficient constant, to determine if this parameter governs the amount of swirl decrease. Pressure measurements should be made with mass injection also, and some studies on optimizing the effects of a given mass flow should be conducted.

REFERENCES

1. GARODZ, L. J., "Federal Aviation Administration Full-Scale Aircraft Vortex Wake Turbulence Flight Test Investigations: Past, Present, Future," AIAA Paper 71-97, January 1971.
2. "Wake Turbulence," DOT-FAA Advisory Circular No. 90-23B, 19 February 1971.
3. BIRD, J. D. and Riley, D. R., "Some Experiments on Visualization of Flow Fields Behind Low Aspect Ratio Wings by Means of a Tuft Grid," NACA TN 2674.
4. SPRIETER, J. D. and Sacks, A. H., "The Rolling Up at the Trailing Vortex Sheet and its Effect on the Downwash Behind Wings," JAS, January 1951, pp. 21.
5. HACKET, J. E. and Evans, M. R., "Vortex Wakes Behind High Lift Wings," Journal of Aircraft, May 1971, pp. 334.
6. GASPAREK, "Decay of a Viscous Trailer Vortex," M.S. Thesis, Syracuse University, June 1960.
7. RINEHART, S. A., "Effects of Modifying a Rotor Tip Vortex by Injection on Downwash Velocities, Noise and Airloads," Presented at Joint Symposium on Environmental Effects on VTOL Designs, Arlington, Texas, November, 1970.

SPECIAL DISTRIBUTION

Mr. Blair Gloss (3 copies)
Mail Stop 404A
NASA - LRC
Hampton, Virginia 23365

Mr. Leo J. Garodz (2 copies)
Engineer, Flight Test Section
NAFEC - FAA
Atlantic City, New Jersey 08405

Dr. Barnes McCormick
Department of Aerospace Engineering
Pennsylvania State University
University Park, Pennsylvania 16802

Mr. William A. McGowan (3 copies)
NASA - Code RAO
600 Independence Avenue, S. W.
Washington, D. C. 20546

Mr. R. Earl Dunham, Jr.
NASA - LRC
Hampton, Virginia 23365

Mr. Coleman Donaldson
Aero Research Assoc. of Princeton, Inc.
50 Washington Road
Princeton, New Jersey 08540

Mr. Fernando L. Fernander
The Aerospace Corporation
1111 E. Mill Street
P. O. Box 5866
San Bernardino, California 92408

Mr. J. E. Hackett
Lockheed - Georgia Company
Marietta, Georgia 30060

Mr. George Bates (3 copies)
FAA - RD 700
FOB 10A
Washington, D. C.

Mr. John F. Spurling (20 copies)
Building E-108
NASA - Wallops Station
Wallops Island, Va. 23337

Mr. R. L. Krieger (2 copies)
Building F-6
NASA - Wallops Station
Wallops Island, Va. 23337

Mr. A. D. Spinak
Building F-6
NASA - Wallops Station
Wallops Island, Va. 23337

Dr. F. R. DeJarnette
Mechanical & Aerospace Dept.
N. C. State University
Raleigh, North Carolina 27607

Dr. F. O. Smetana
Mechanical & Aerospace Dept.
N. C. State University
Raleigh, N. C. 27607

Mr. Richard P. White, Jr.
Vice President
and Director of Engineering
Rochester Applied Science
140 Allens Creek Road
Rochester, New York 14618

TABLE I. WING CHARACTERISTICS

Chord = 2/3 ft.
 Semi-span = 4 ft.
 Angle of Attack = 7-1/2°
 Airfoil = NACA 0012
 $Re_C = 2.8 \times 10^5, 3.6 \times 10^5, 5.5 \times 10^5$
 $C_L = .674$

TABLE II. JET OPERATING CONDITIONS

<u>Setting</u>	<u>Tunnel Dynamic Press.</u>	<u>Mass Flow Rate (slug/sec)</u>	<u>Jet Coeff. (C_{μ})</u>
Moderate Blowing	1" H ₂ O	.000213	.022
" "	2" H ₂ O	"	.012
" "	5" H ₂ O	"	.0045
Full Blowing	1" H ₂ O	.000375	.078
" "	2" H ₂ O	"	.039
" "	5" H ₂ O	"	.0156

TABLE III. SUMMARY OF DATA FIGURES

<u>Figure</u>	<u>Tuft Grid Position</u> z/c	<u>Wing Config.</u>	<u>Tunnel Dynamic Pressure</u> (in H ₂ O)	<u>Mass Inj.</u> (Slugs/Sec.)	<u>Jet Coeff.</u> C _μ
8	3.2, 14.4, 20.0, 28.5	Clean	1	0	0
9	3.2, 14.4, 20.0, 28.5	Clean	2	0	0
10	3.2, 14.4, 20.0, 28.5	Clean	5	0	0
11	3.2, 12.4, 20.0, 28.5	Modified	1	0.0	0
12	3.2, 12.4, 20.0, 28.5	Modified	1	.000213	0.022
13	3.2, 12.4, 20.0, 28.5	Modified	1	.000375	0.078
14	3.2, 12.4, 20.0, 28.5	Modified	2	0.0	0
15	3.2, 12.4, 20.0, 28.5	Modified	2	.000213	0.012
16	3.2, 12.4, 20.0, 28.5	Modified	2	.000375	0.039
17	3.2, 12.4, 20.0, 28.5	Modified	5	0.000	0
18	3.2, 12.4, 20.0, 28.5	Modified	5	0.000213	0.0045
19	3.2, 12.4, 20.0, 28.5	Modified	5	0.000375	0.0156

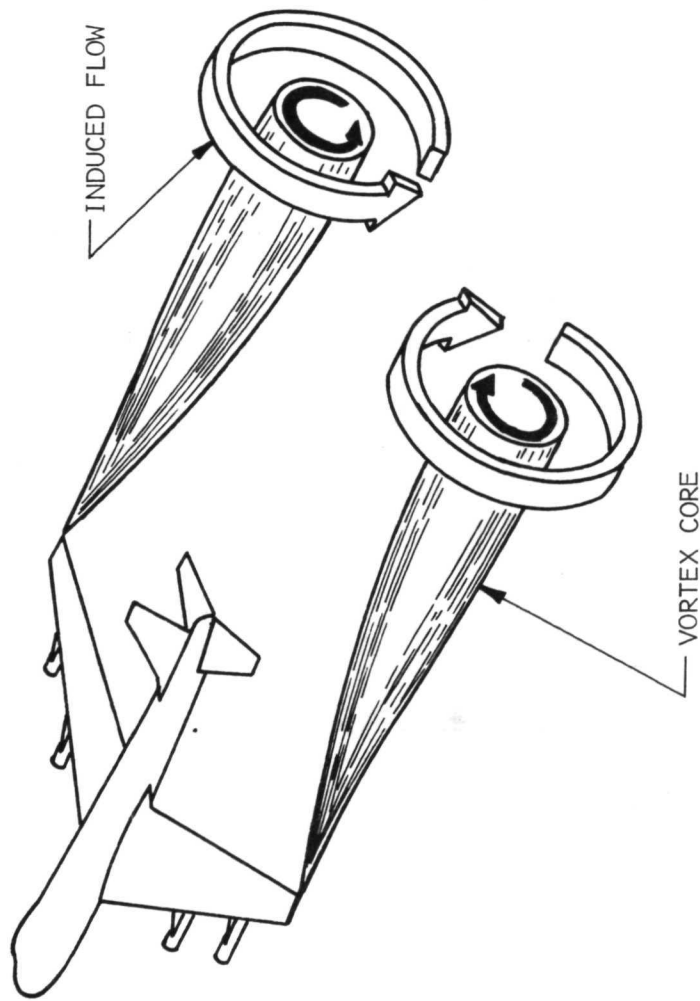

Fig. 1. Diagrammatic Illustration of Trailing Vortices.

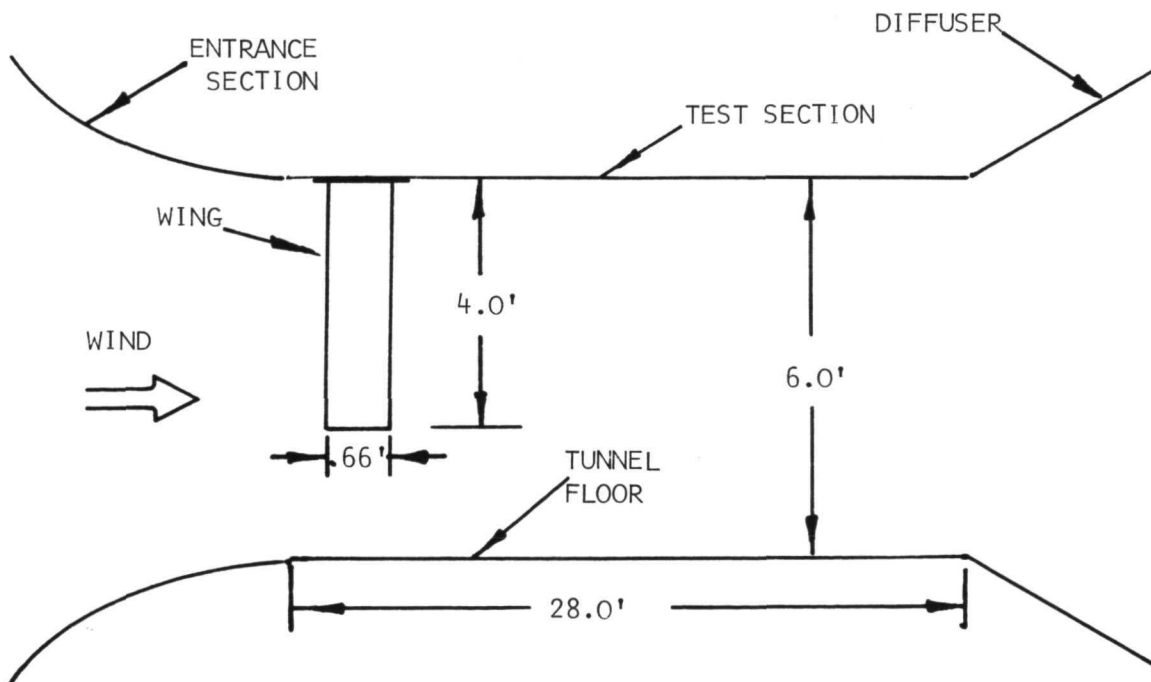
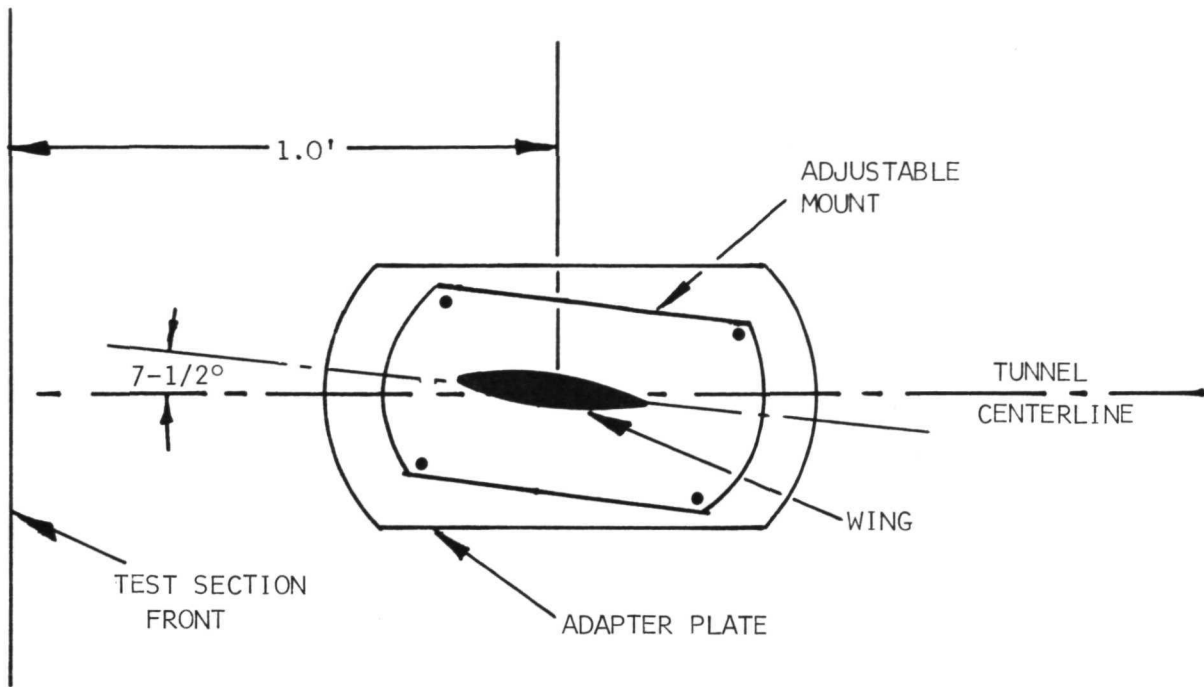

Fig. 2. Wing Installation.

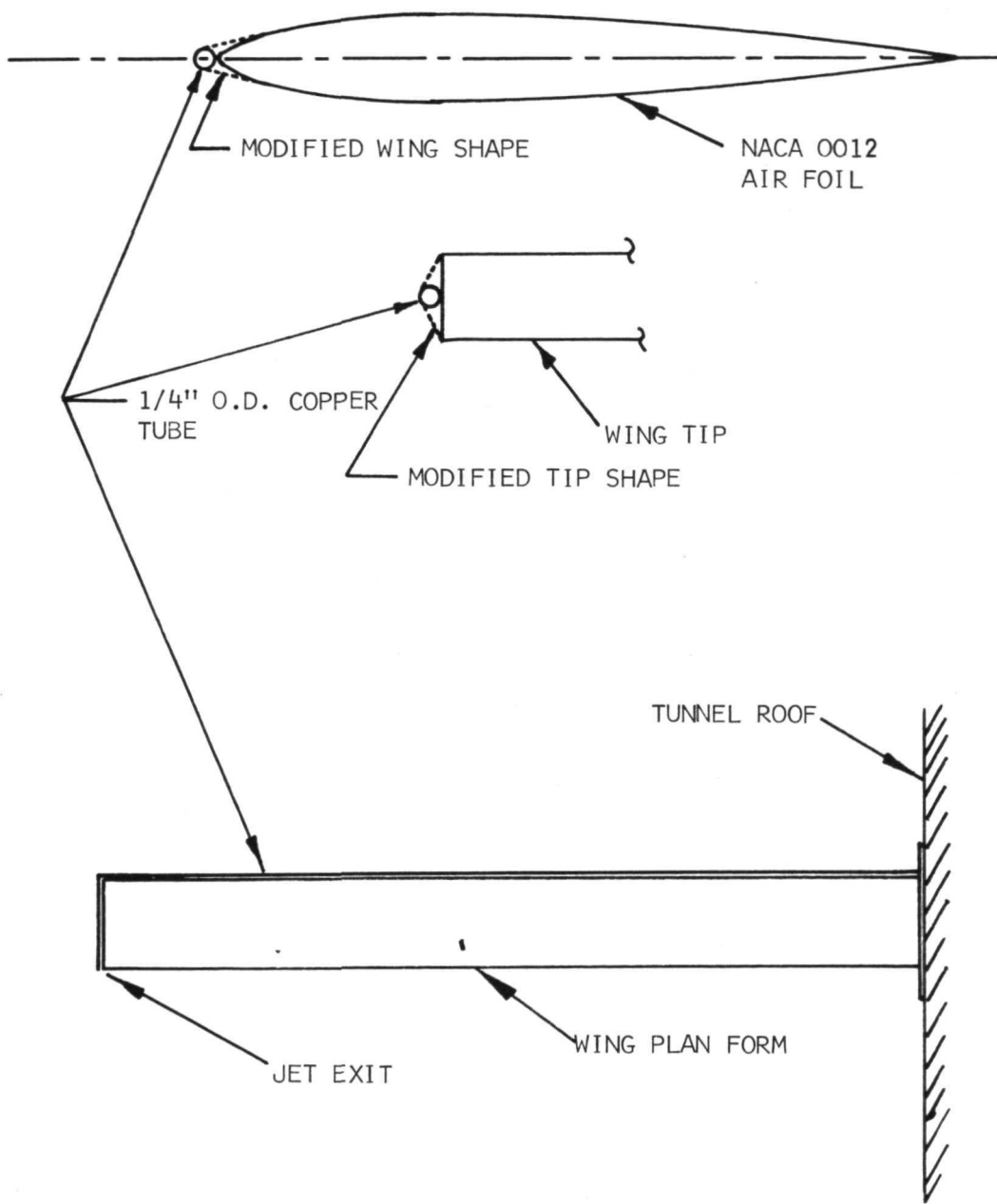

Fig. 3. Sketch of Wing and Modification.

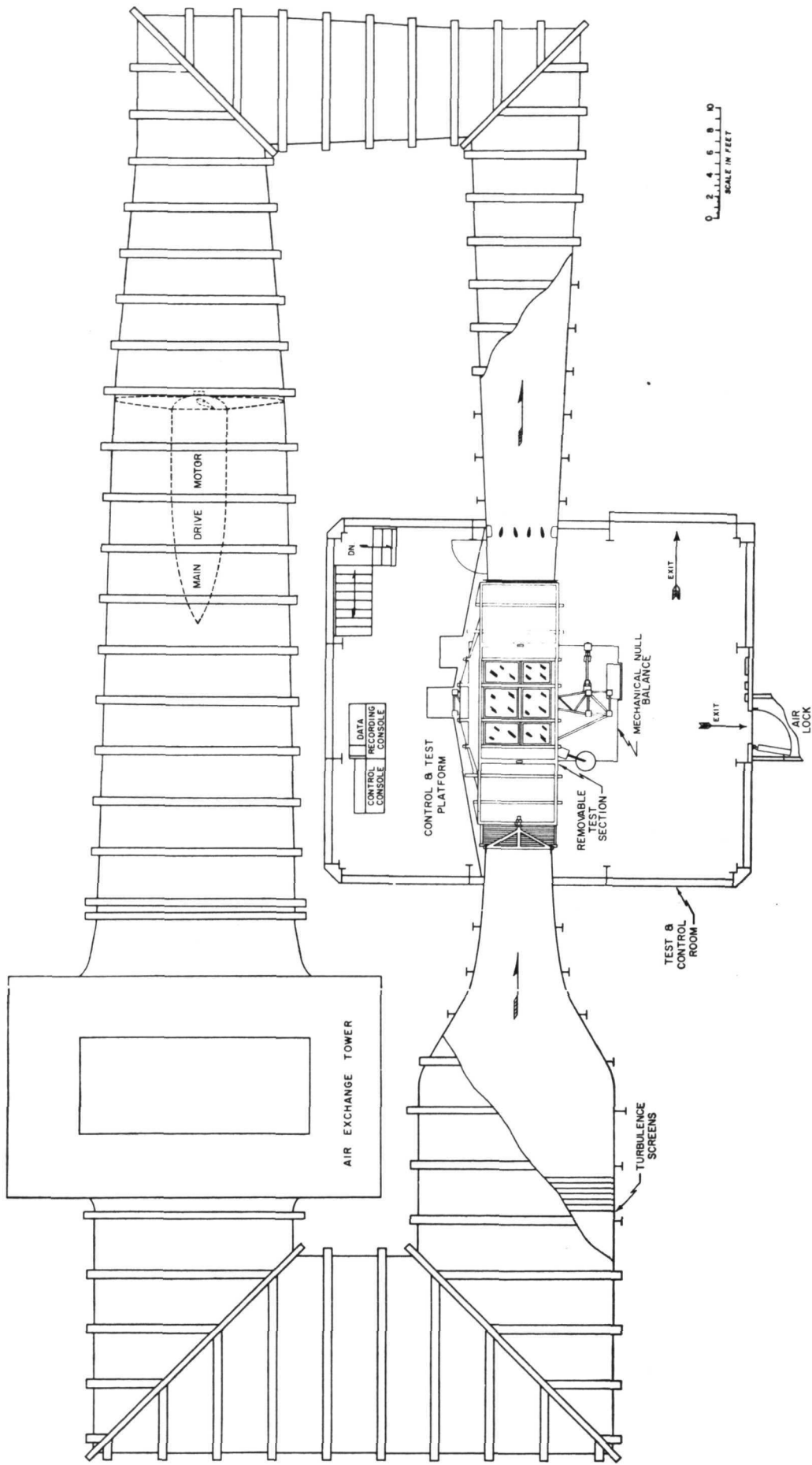

Fig. 4. Tunnel Schematic.

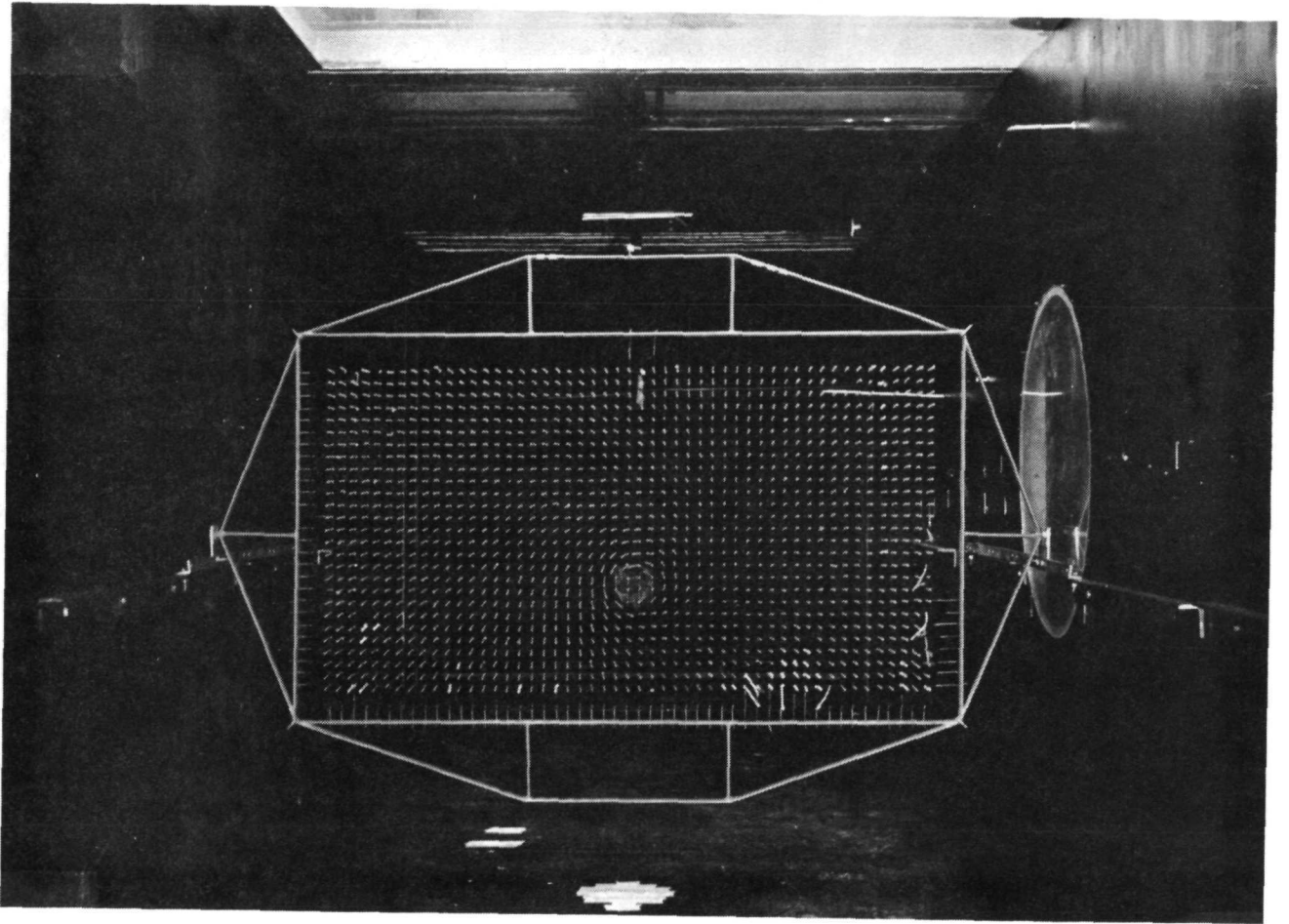

Fig. 5. Tuft Grid Installation.

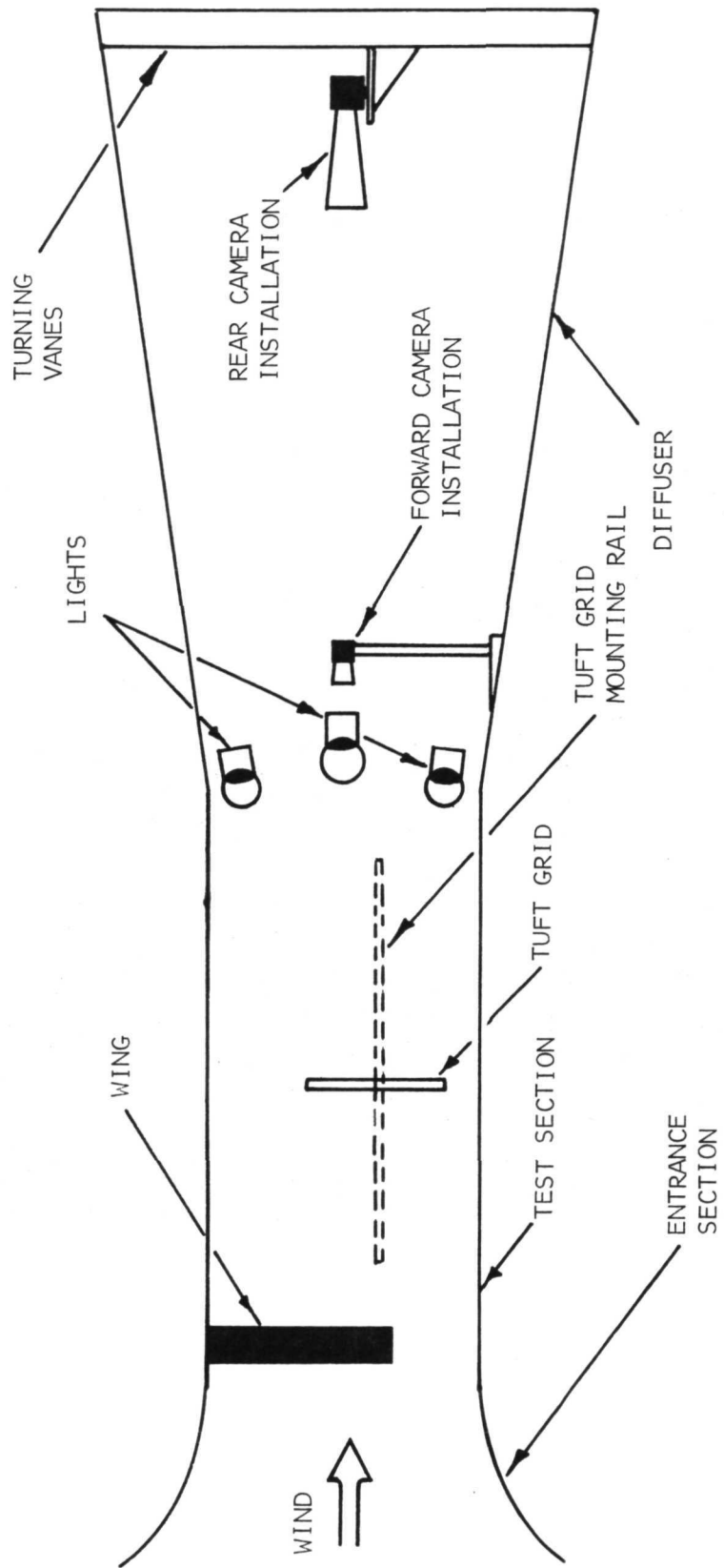

Fig. 6. General Layout of Apparatus

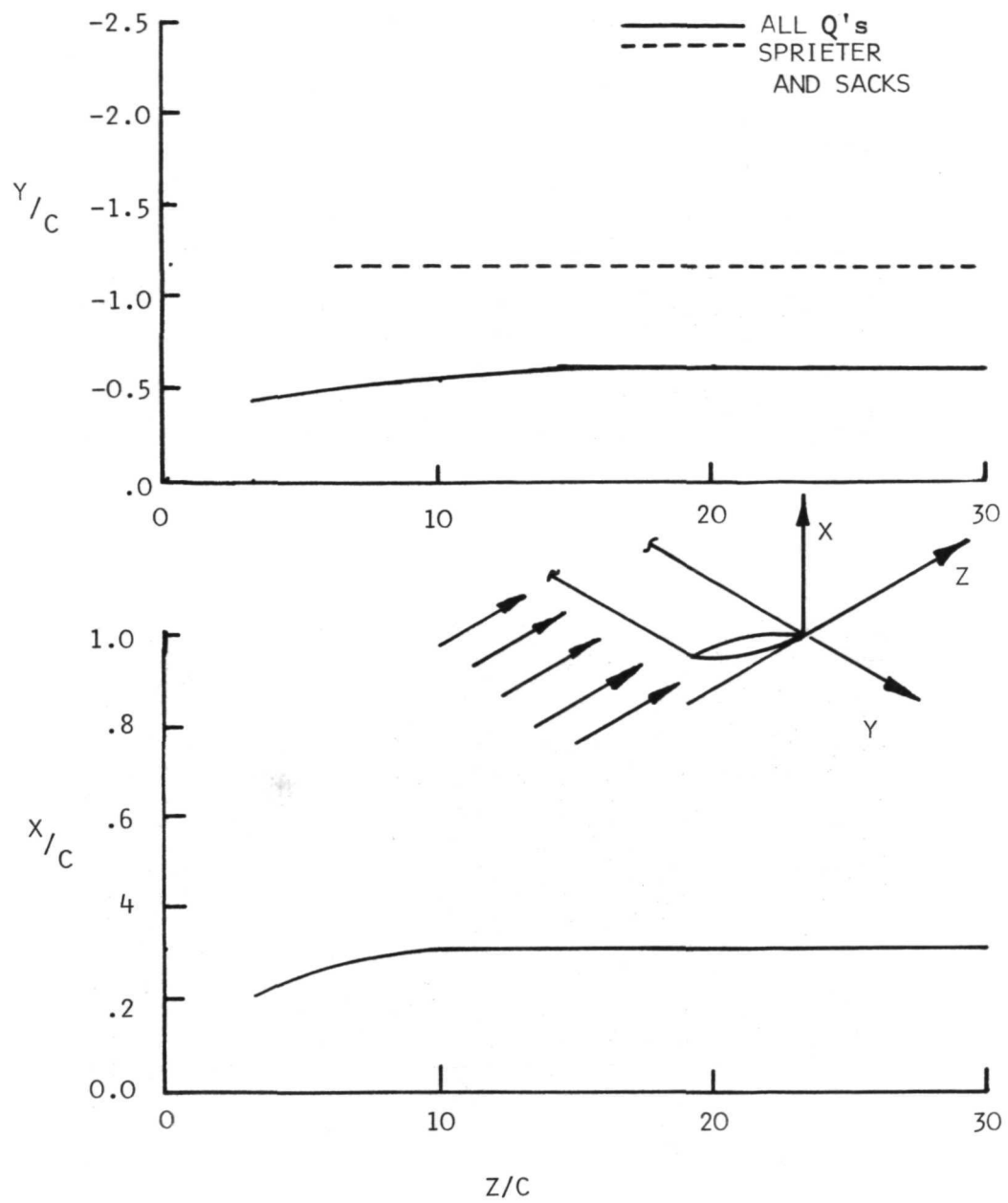
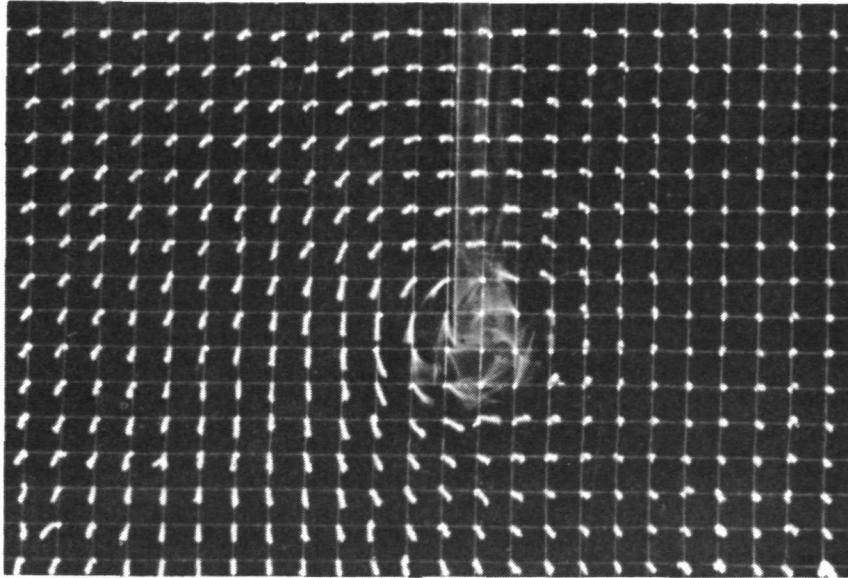
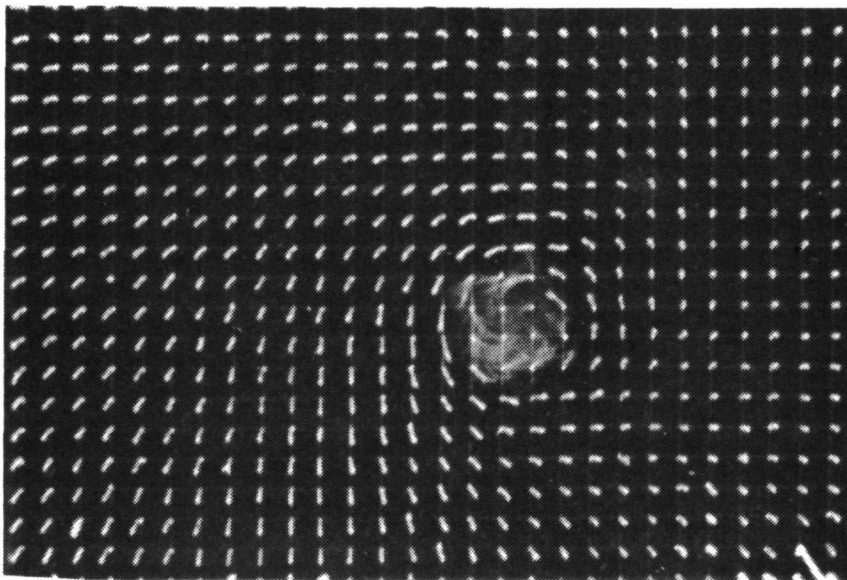

Fig. 7. Position of Vortex in Tunnel



$Z/C = 3.4$



$Z/C = 14.2$

Fig. 8. Tuft Grid Survey, $Q = 1.0'' \text{ H}_2\text{O}$,
 $Z/C = 3.4, 14.2, 20.0, 28.5.$

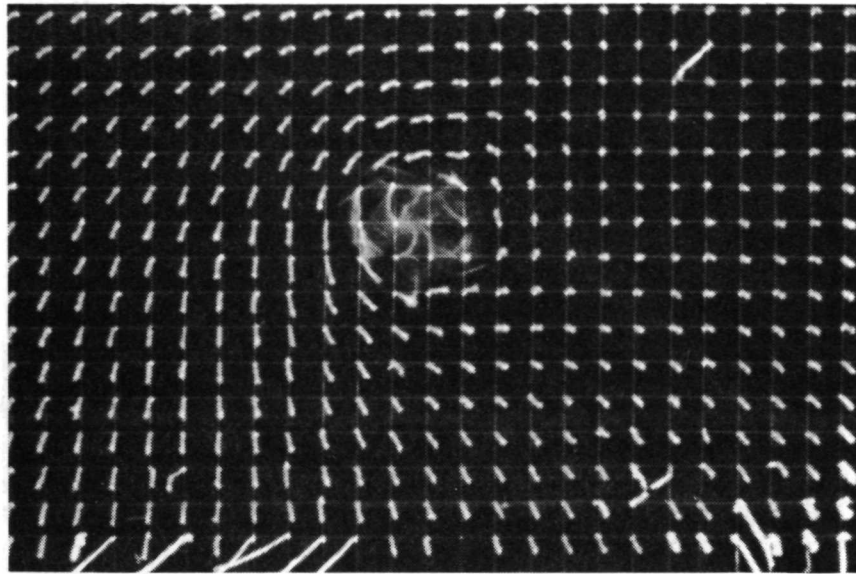

$Z/C = 20.0$

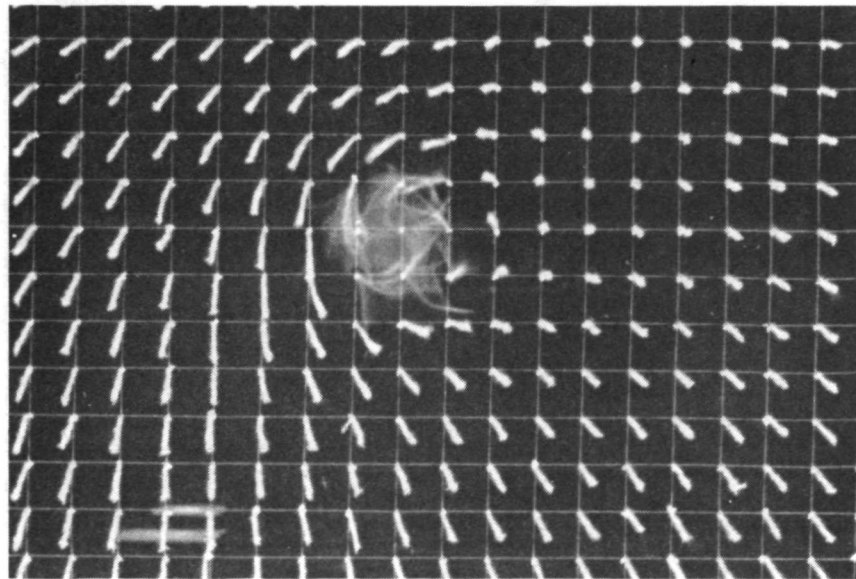

$Z/C = 28.5$

Fig. 8. Continued.

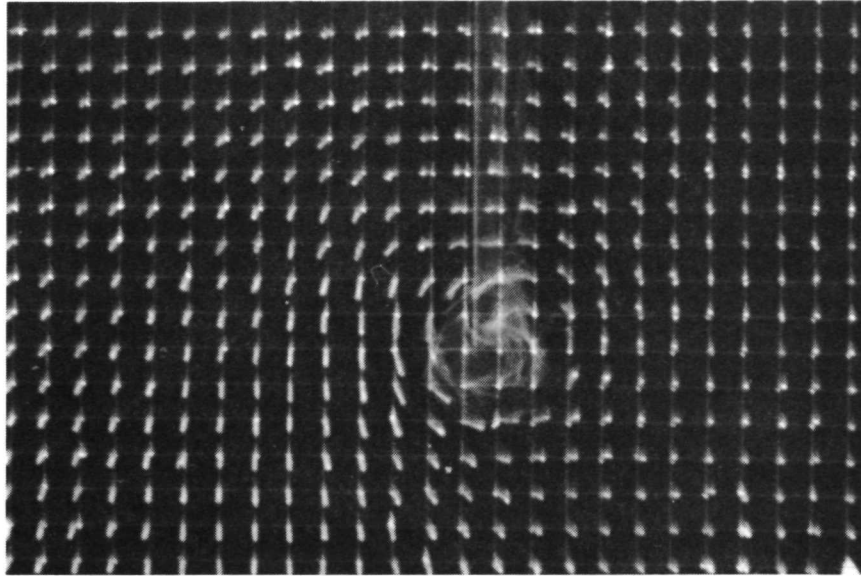

$Z/C = 3.4$

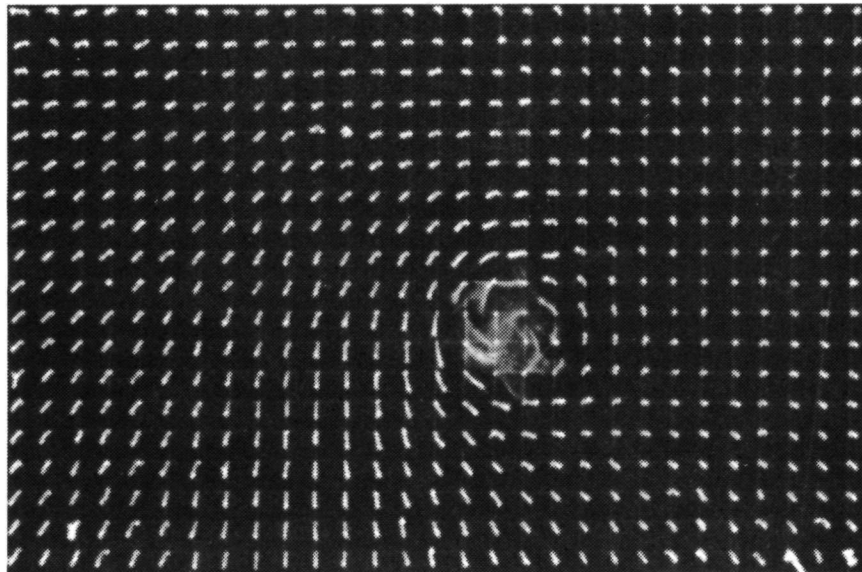

$Z/C = 14.2$

Fig. 9. Tuft Grid Survey, $Q = 2.0 \text{ H}_2\text{O}$,
 $Z/C = 3.4, 14.2, 20.0, 28.5$.

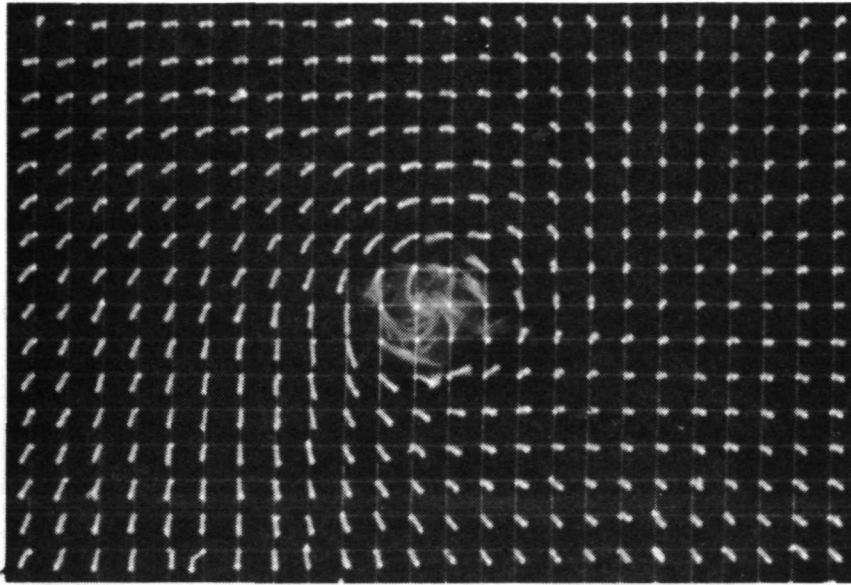

$Z/C = 20.0$

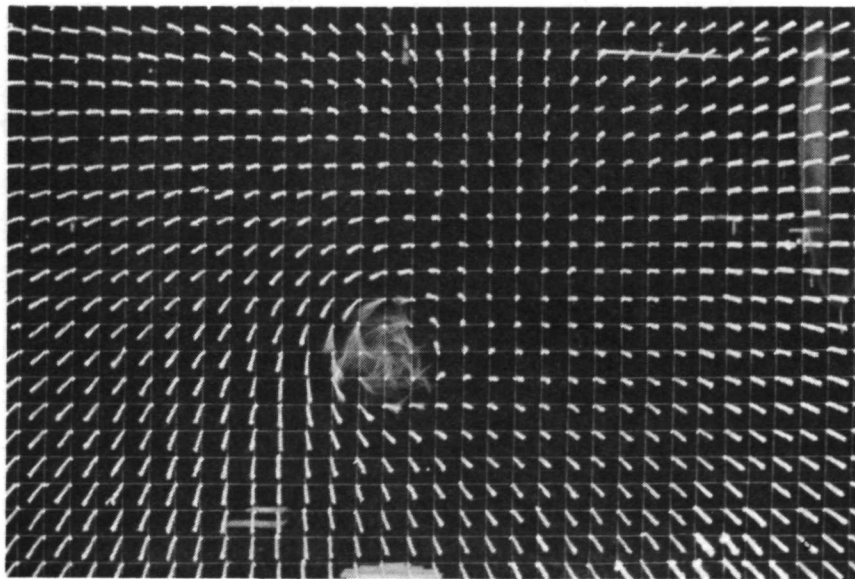

$Z/C = 28.5$

Fig. 9. Continued.

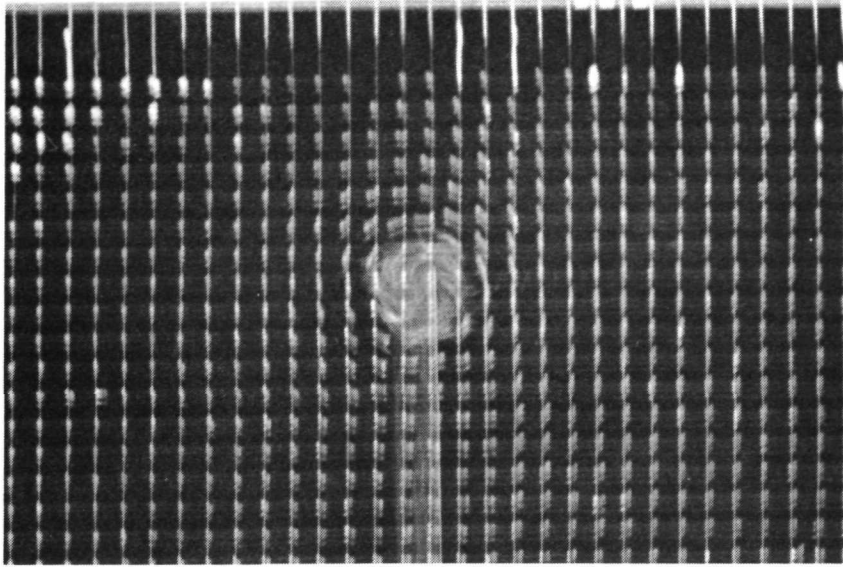

Z/C 3.4

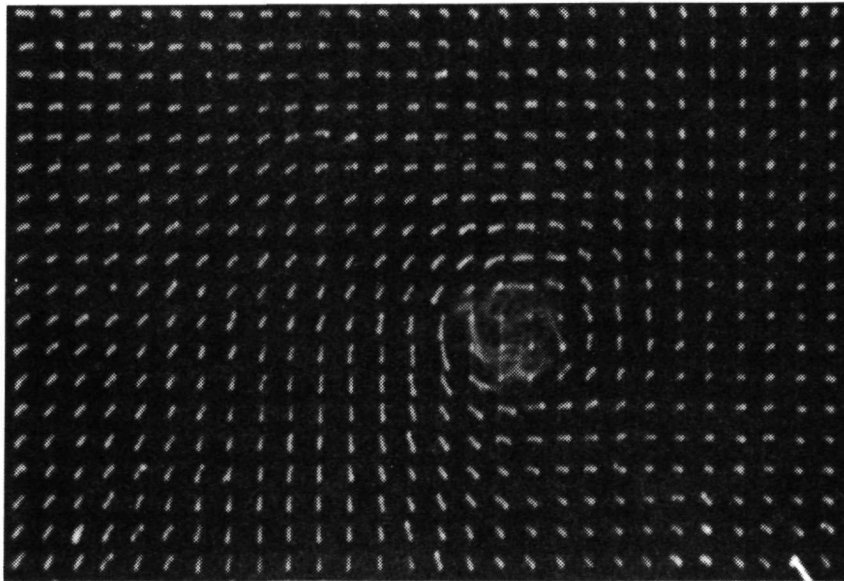

Z/C = 14.2

Fig. 10. Tuft Grid Survey, $Q = 5.0'' \text{ H}_2\text{O}$,
 $Z/C = 3.4, 14.2, 20.0, 28.5.$ ²

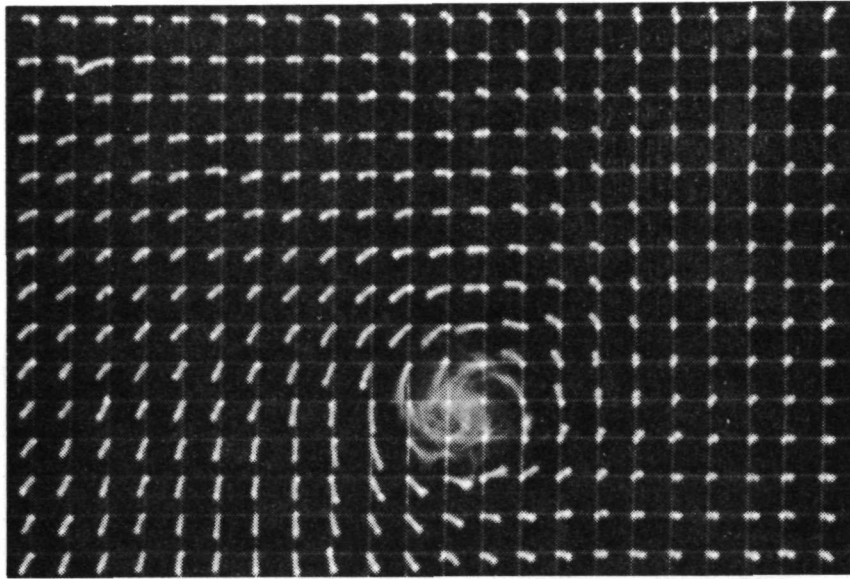

$Z/C = 20.0$

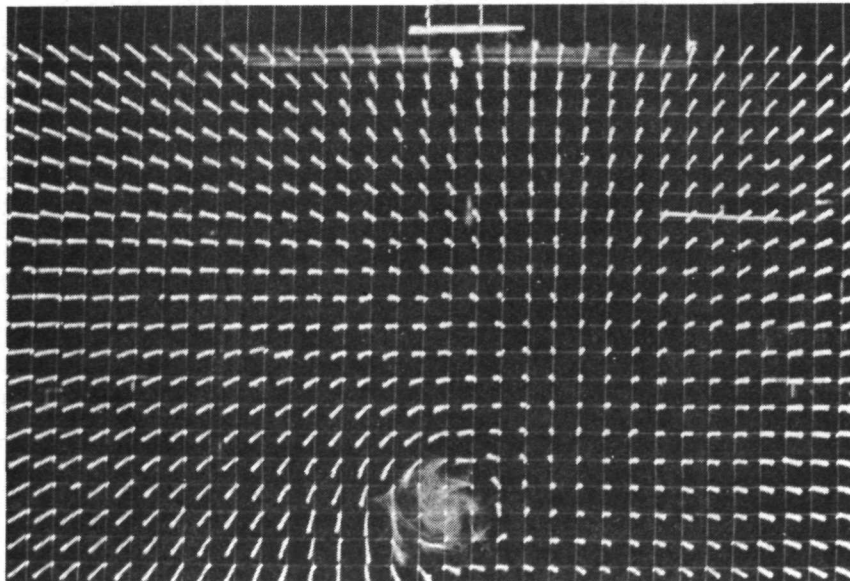

$Z/C = 28.5$

Fig. 10. Continued.

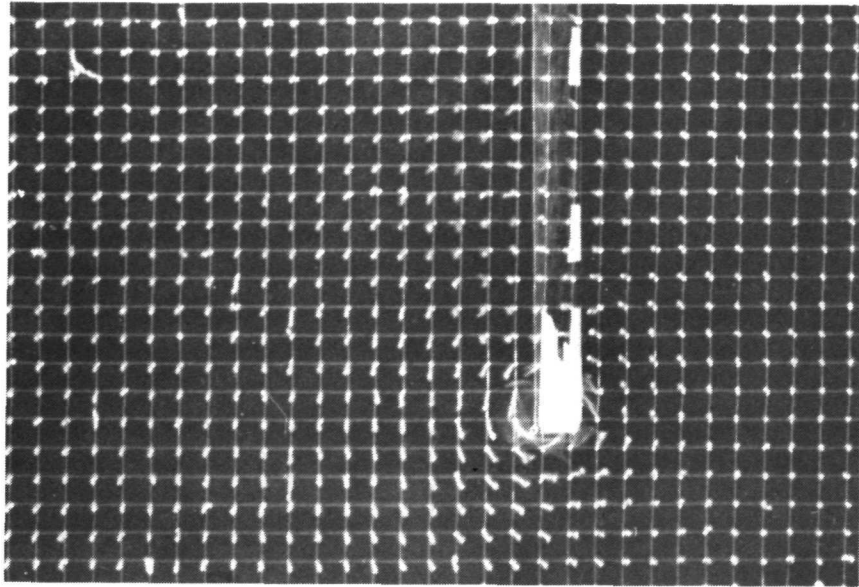

Z/C = 3.4

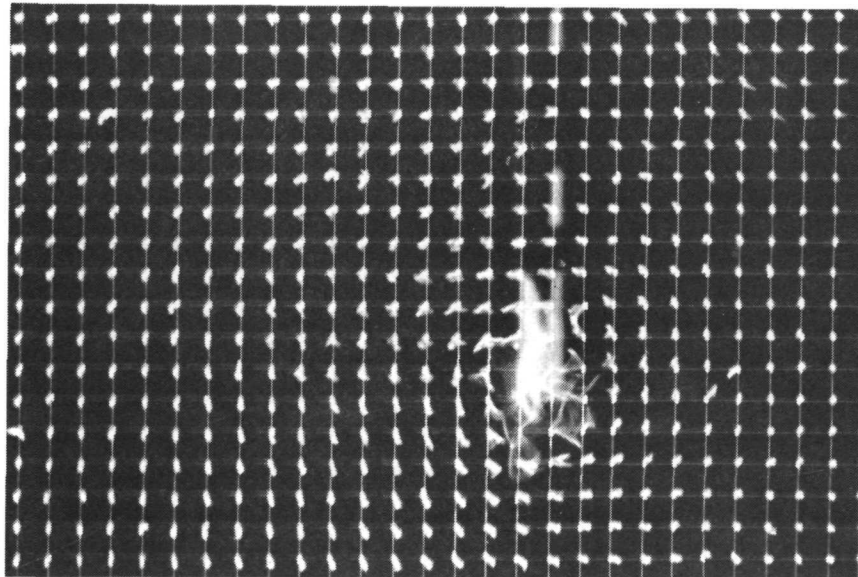

Z/C = 12.3

Fig. 11. Tuft Grid Survey, $Q = 1.0''$, H_2O , No Blowing,
 $Z/C = 3.4, 12.3, 20.0, 28.5.$ ²

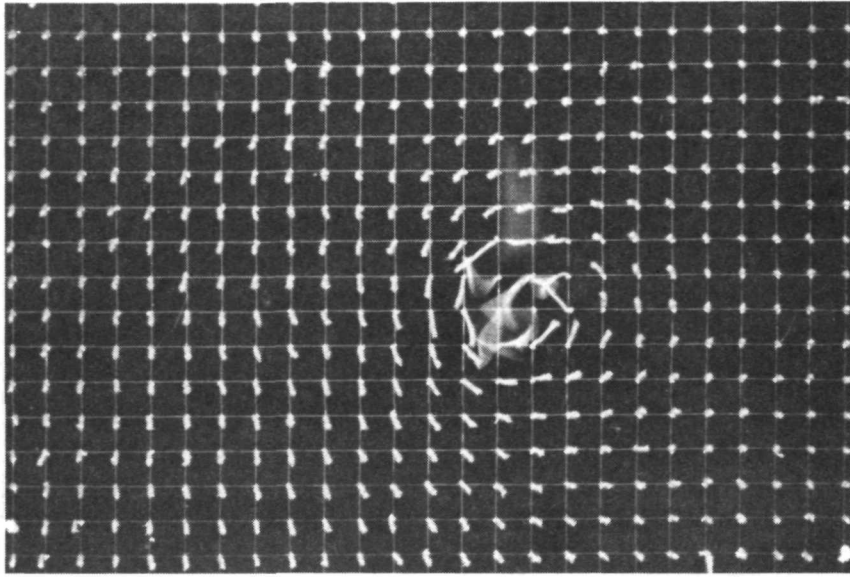

$Z/C = 20.0$

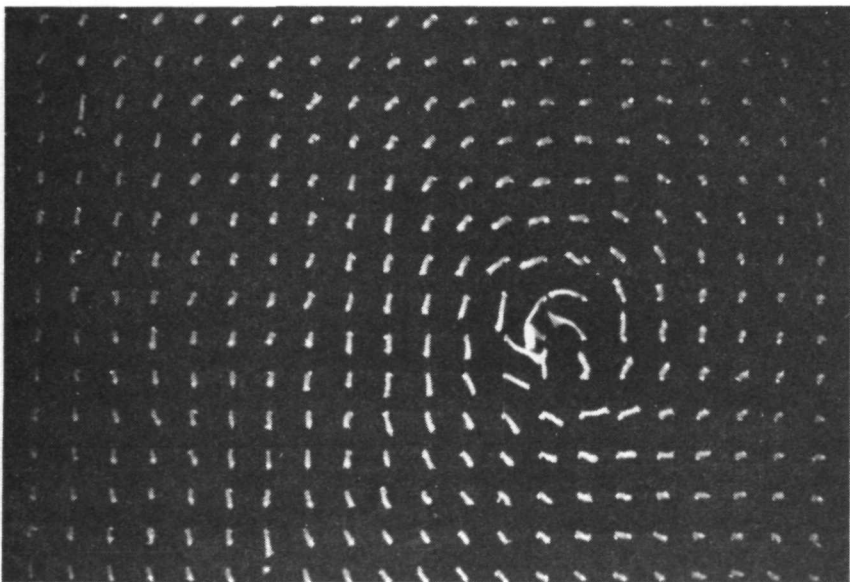

$Z/C = 28.5$

Fig. 11. Continued.

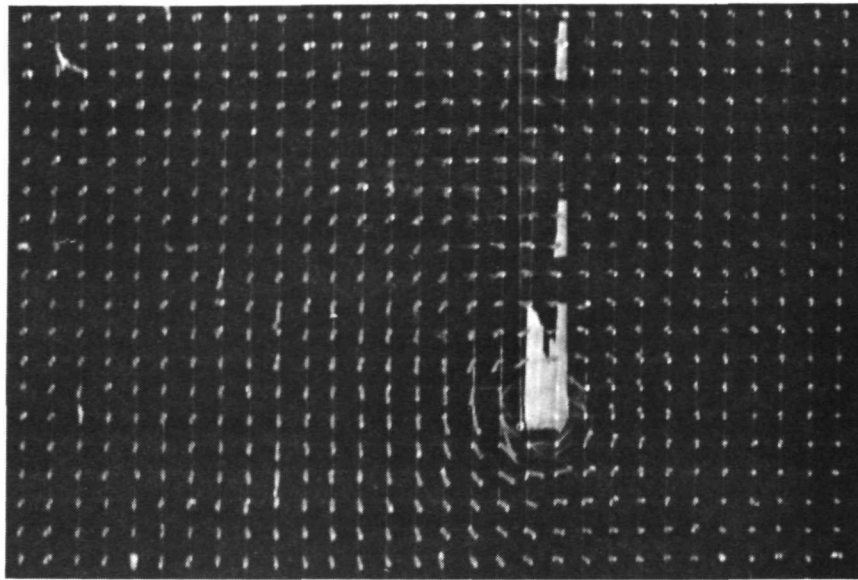

$Z/C = 3.4$

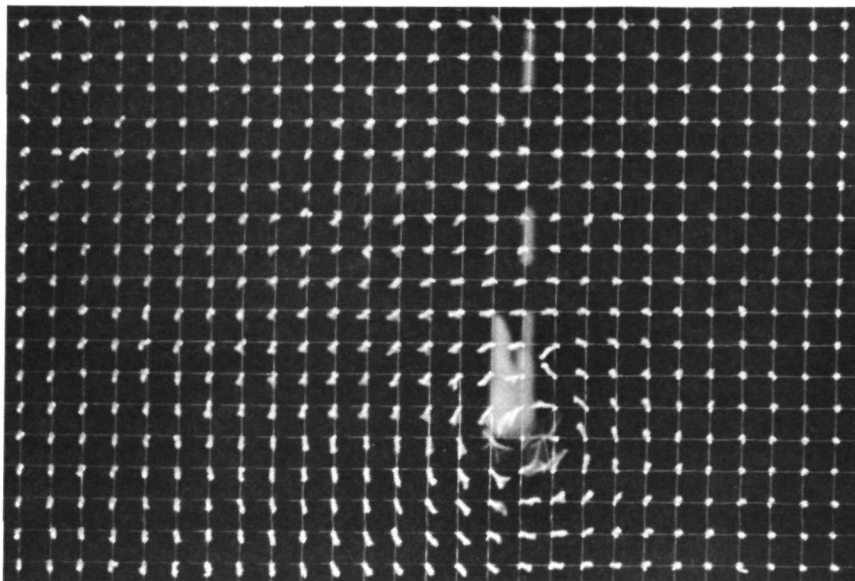

$Z/C = 12.3$

Fig. 12. Tuft Grid Survey, $Q = 1.0''$, H_2O , Moderate Blowing,
 $Z/C = 3.4, 12.3, 20.0, 28.5.$

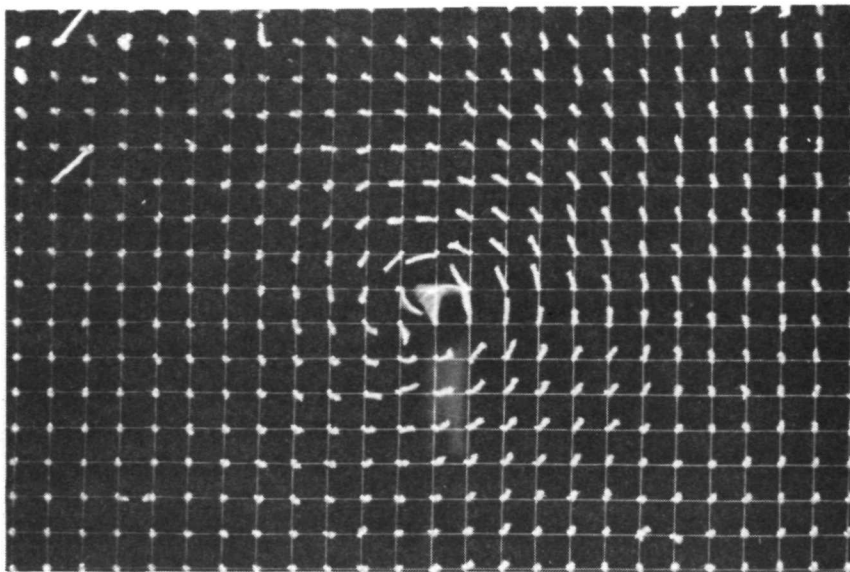

$Z/C = 20.0$

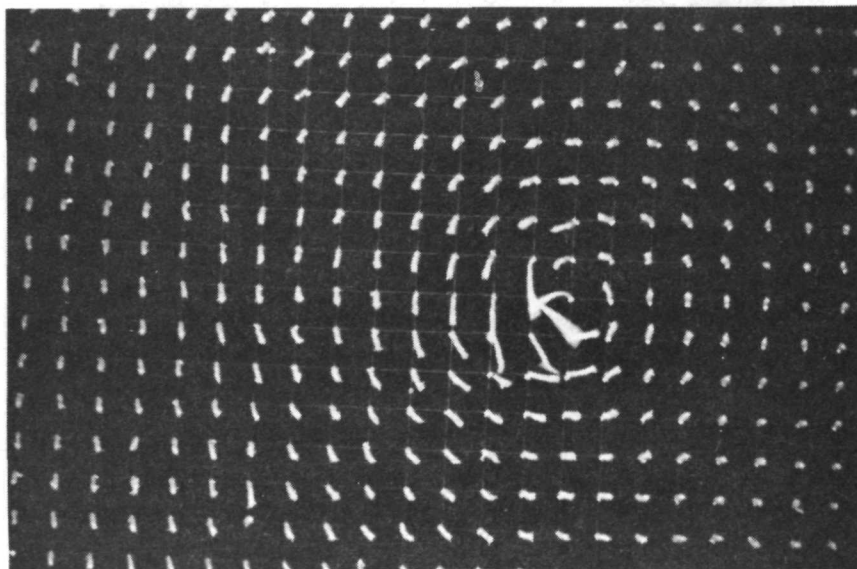

$Z/C = 28.5$

Fig. 12. Continued.

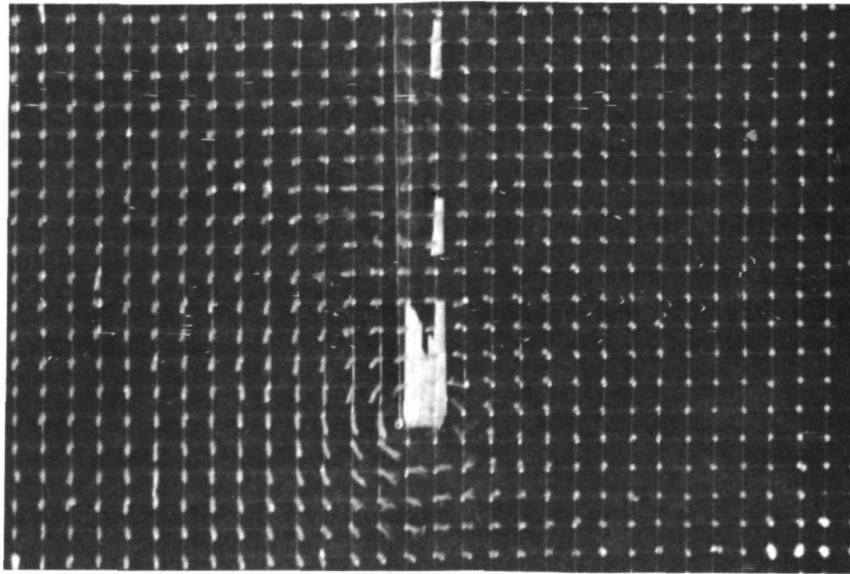

$Z/C = 3.4$

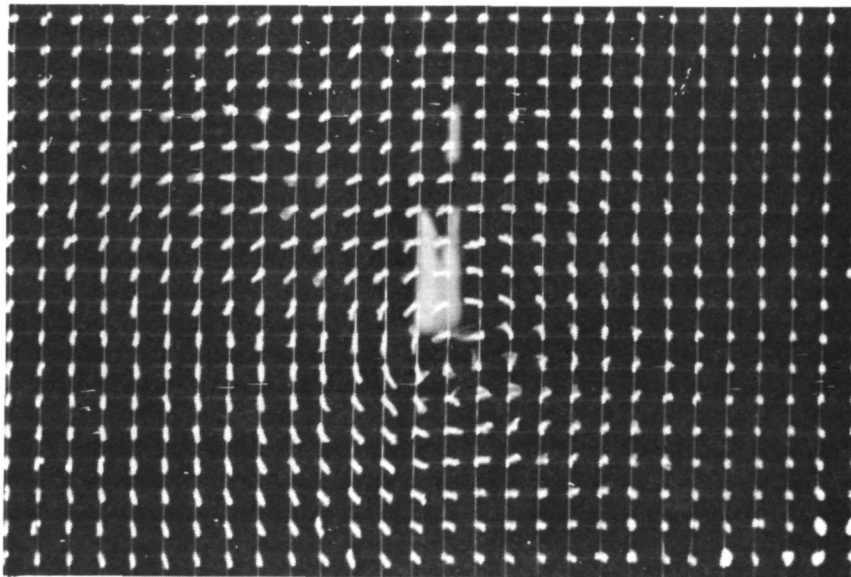

$Z/C = 12.3$

Fig. 13. Tuft Grid Survey, $Q = 1.0''$, H_2O , Full Blowing,
 $Z/C = 3.4, 12.3, 20.0, 28.5.$

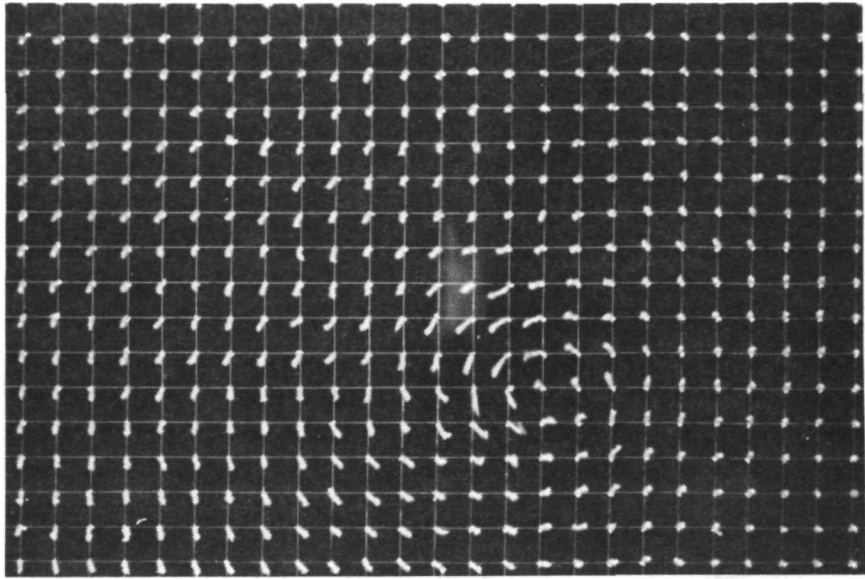

$Z/C = 20.0$

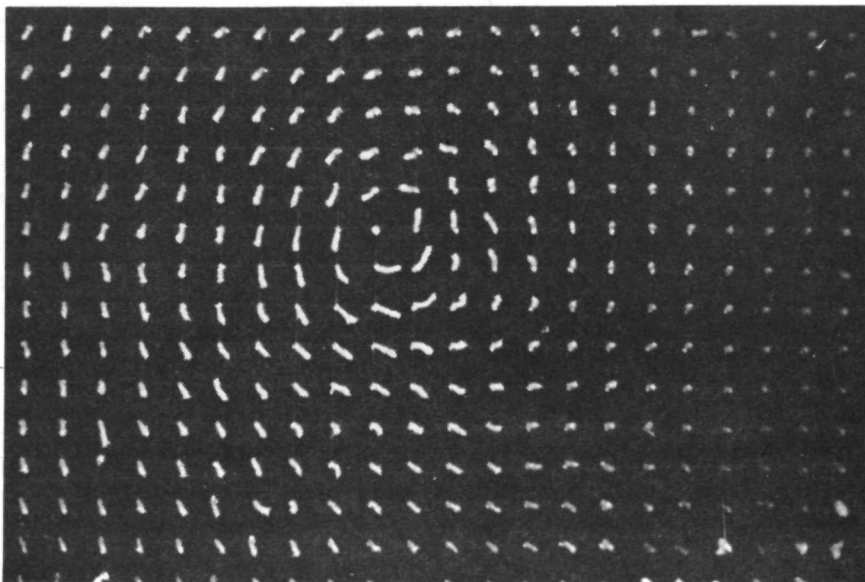

$Z/C = 28.5$

Fig. 13. Continued.

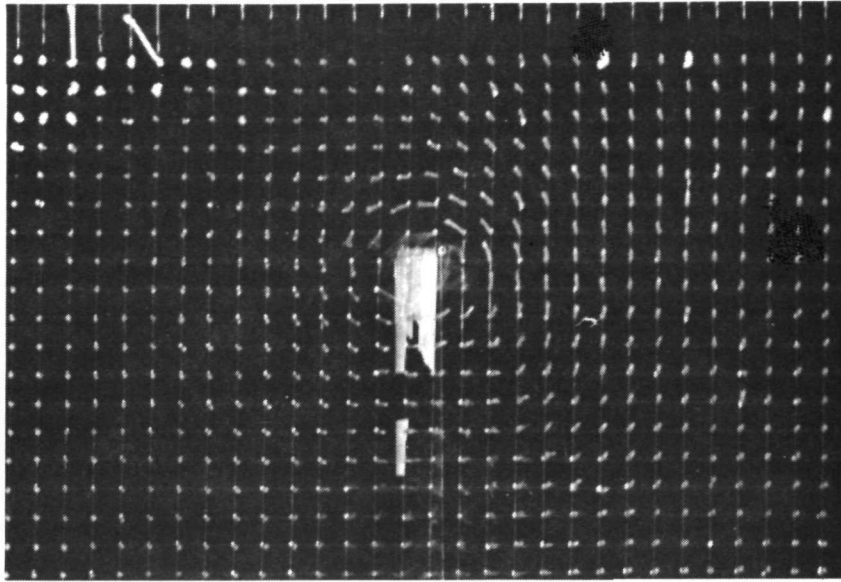

$Z/C = 3.4$

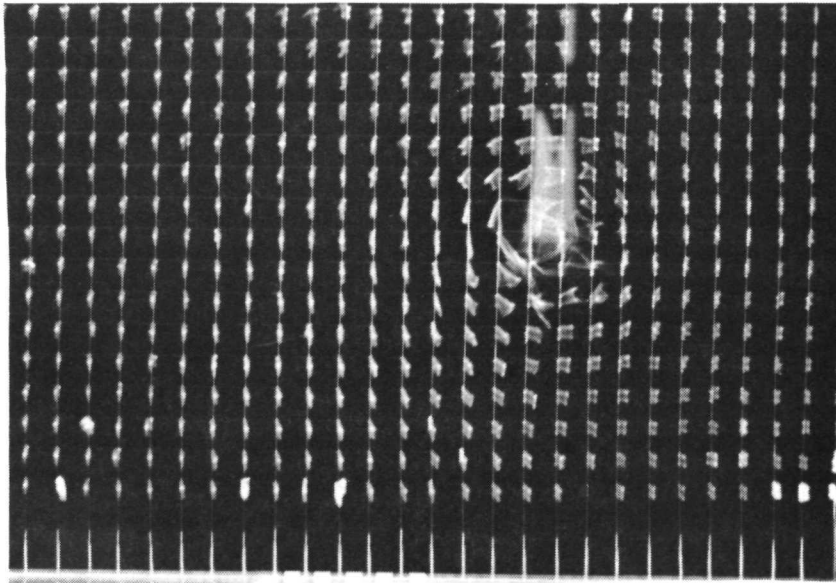

$Z/C = 12.3$

Fig. 14. Tuft Grid Survey, $Q = 2.0'' \text{ H}_2\text{O}$, No Blowing,
 $Z/C = 3.4, 12.3, 20.0, 28.5.$

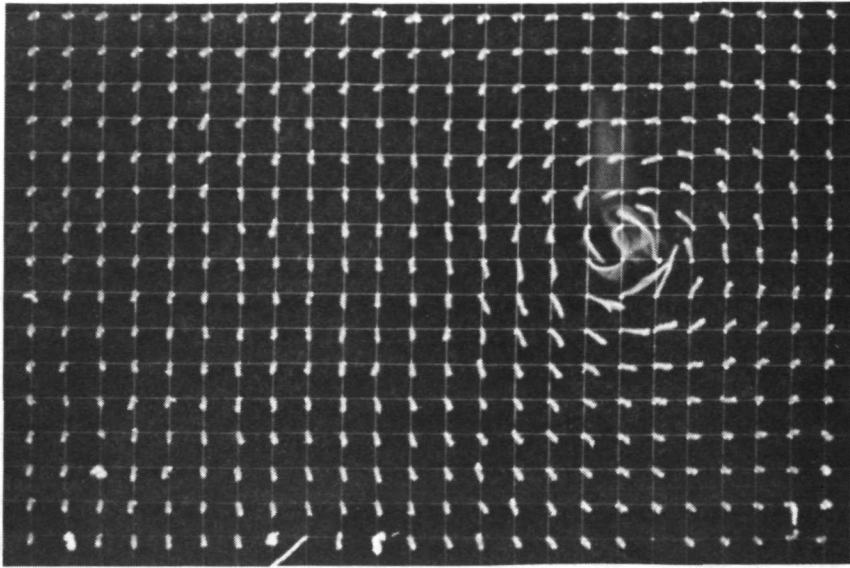

$Z/C = 20.0$

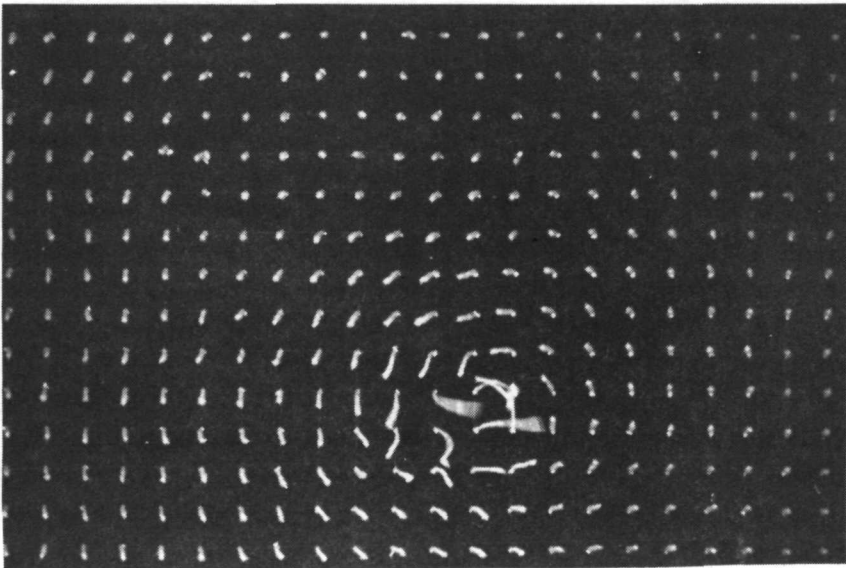

$Z/C = 28.5$

Fig. 14. Continued.

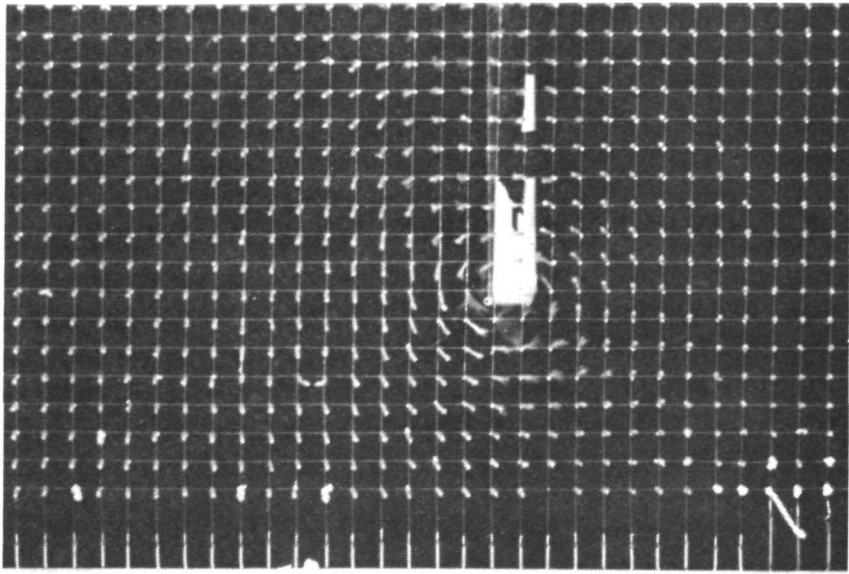

$Z/C = 3.4$

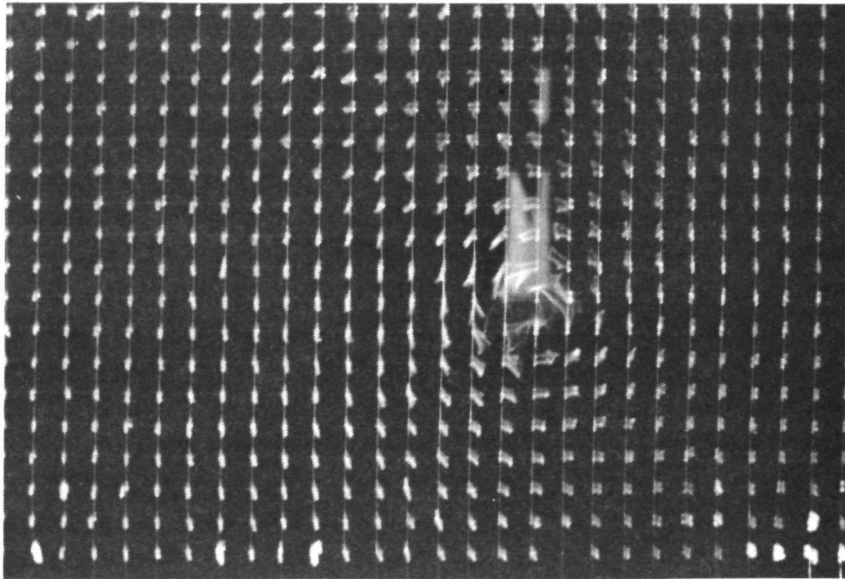

$Z/C = 12.3$

Fig. 15. Tuft Grid Survey, $Q = 2.0'' \text{ H}_2\text{O}$, Moderate Blowing
 $Z/C = 3.4, 12.3, 20.0, 28.5.$

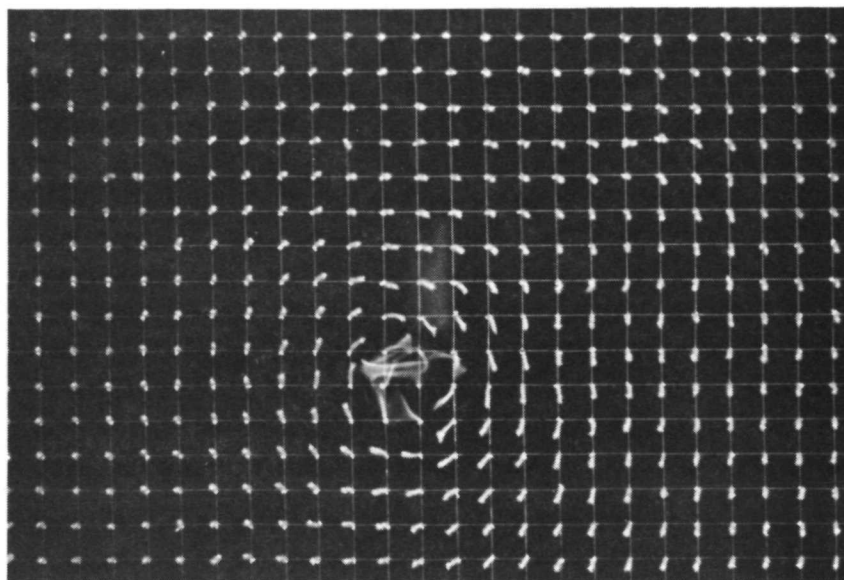

$Z/C = 20.0$

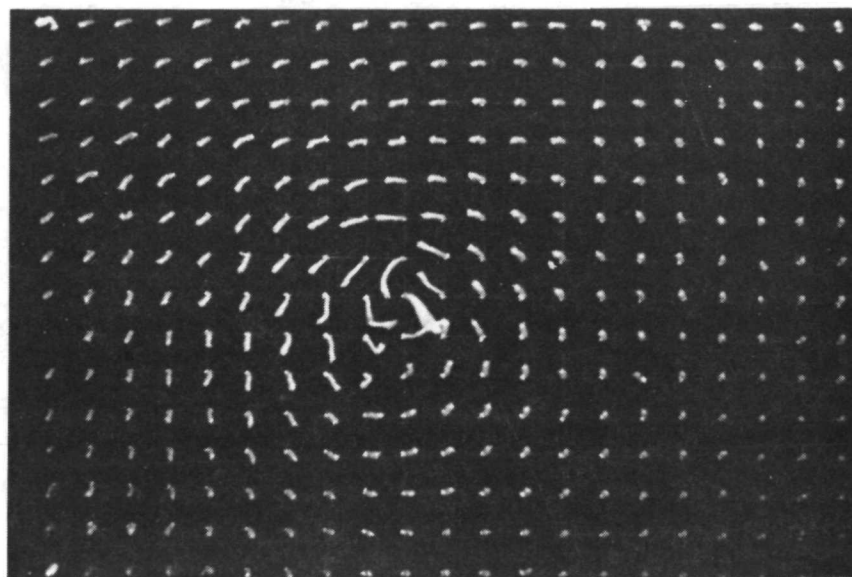

$Z/C = 28.5$

Fig. 15. Continued.

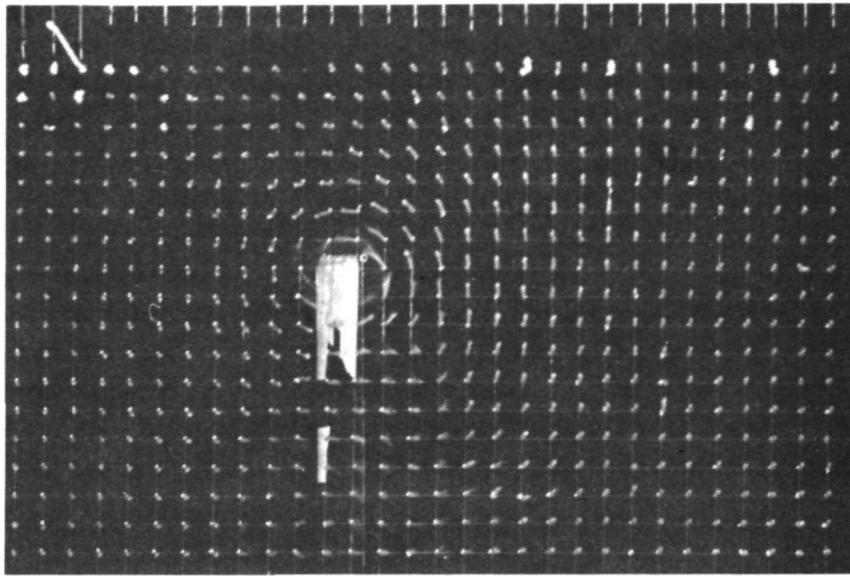

$Z/C = 3.4$

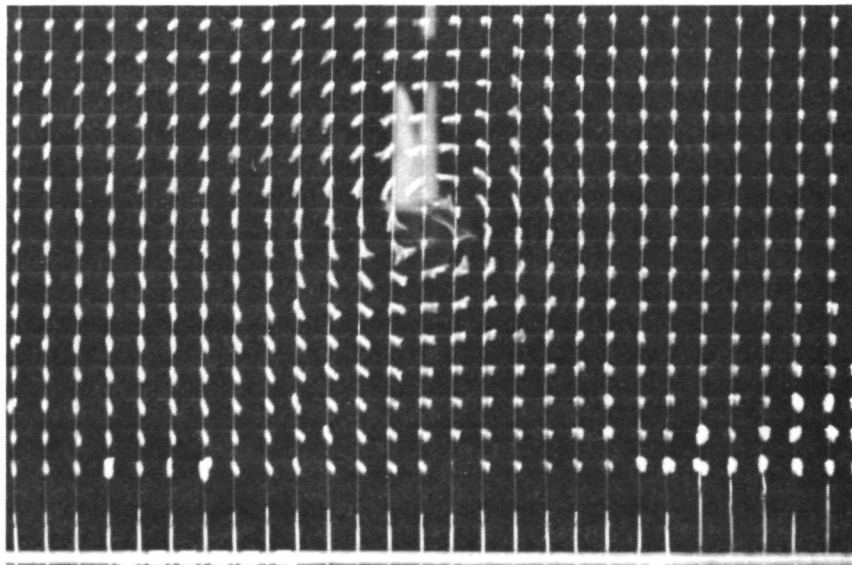

$Z/C = 12.3$

Fig. 16. Tuft Grid Survey, $Q = 2.0'' \text{ H}_2\text{O}$, Full Blowing,
 $Z/C = 3.4, 12.3, 20.0, 28.5.$

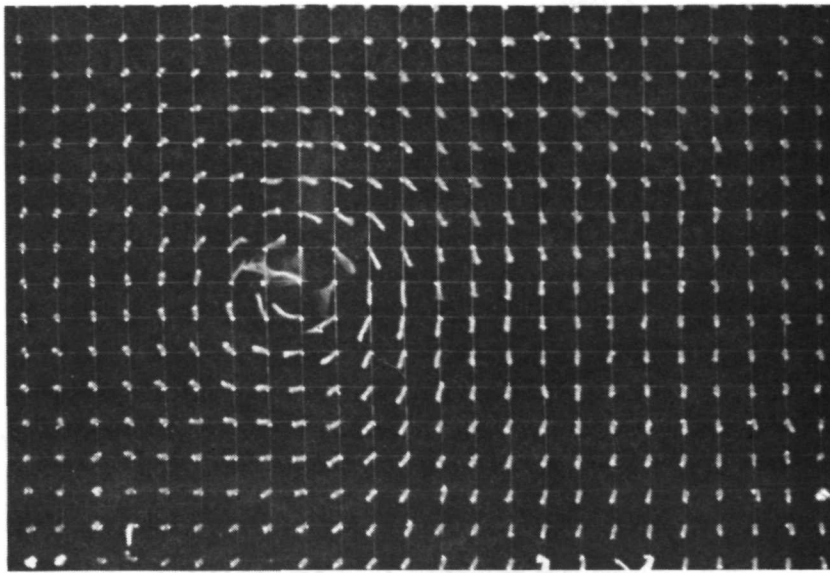

$Z/C = 20.0$

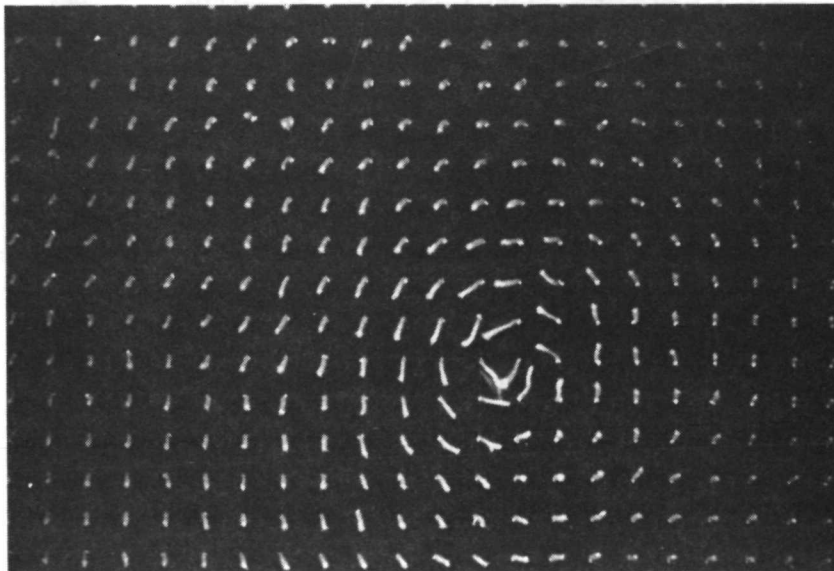

$Z/C = 28.5$

Fig. 16. Continued.

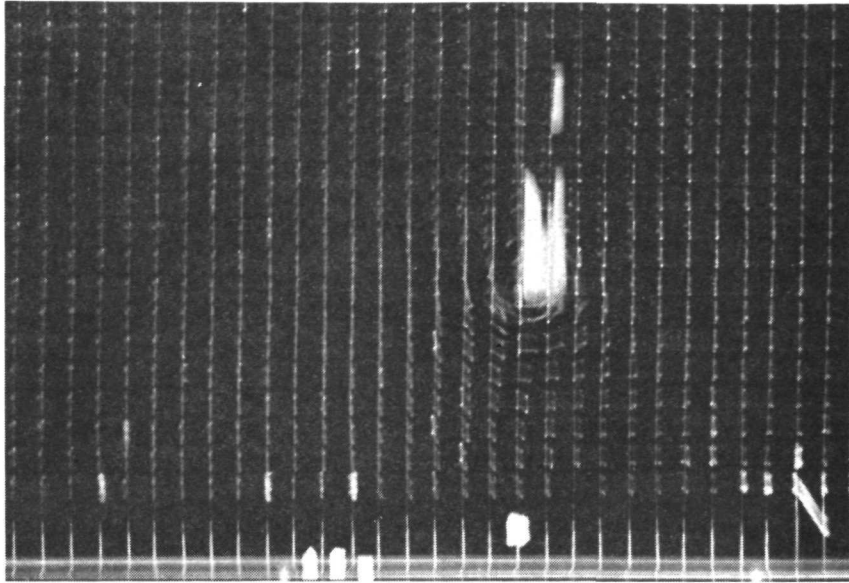

Z/C = 3.4

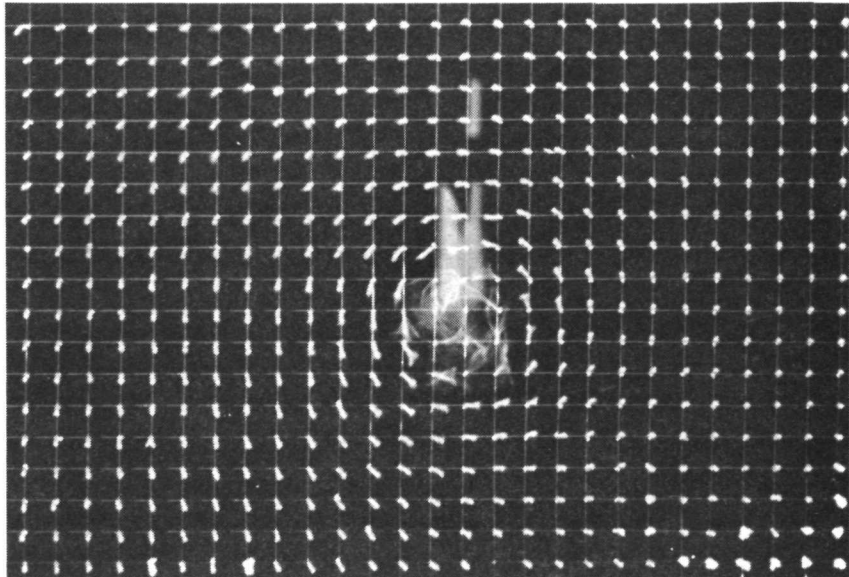

Z/C = 12.3

Fig. 17. Tuft Grid Survey, $Q = 5.0'' \text{ H}_2\text{O}$, No Blowing,
Z/C = 3.4, 12.3, 20.0, 28.5.

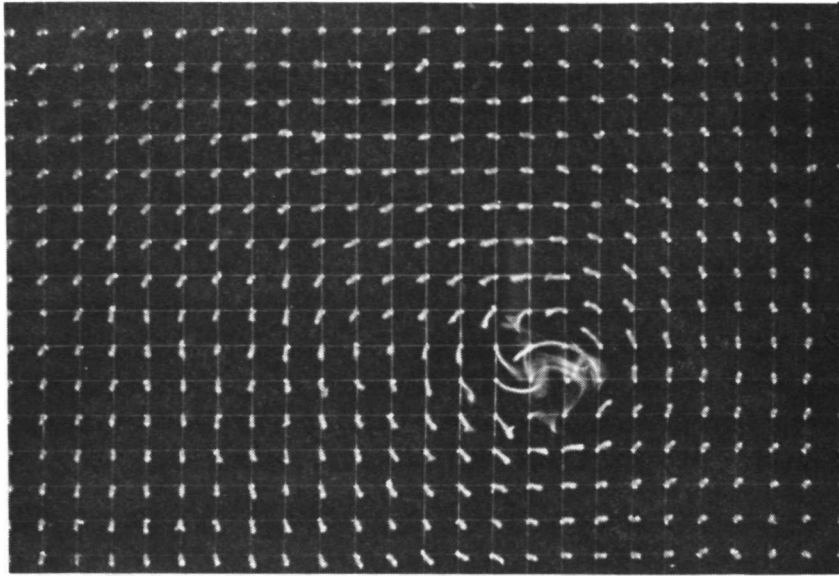

$Z/C = 20.0$

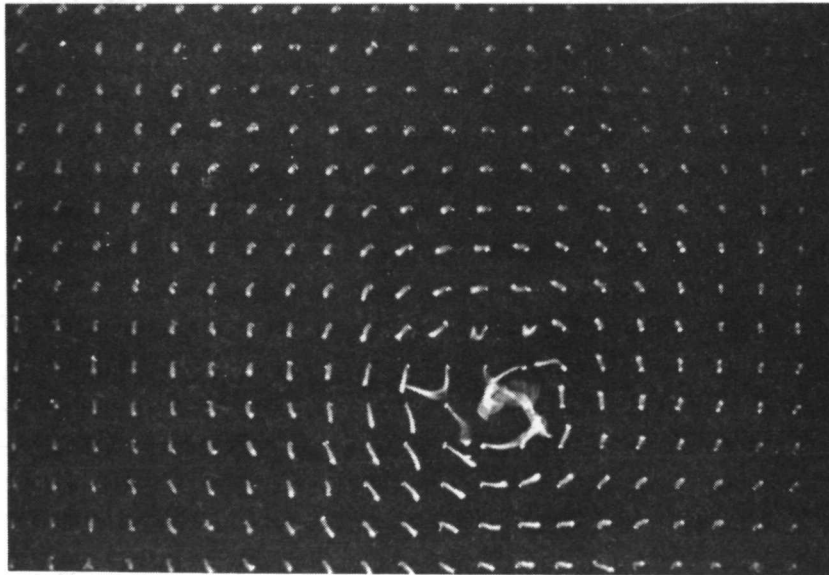

$Z/C = 28.5$

Fig. 17. Continued.

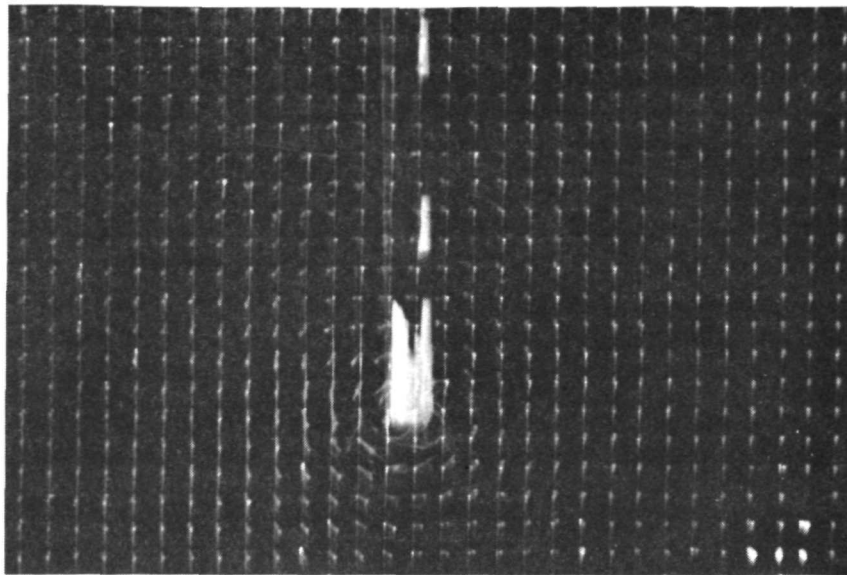

$Z/C = 3.4$

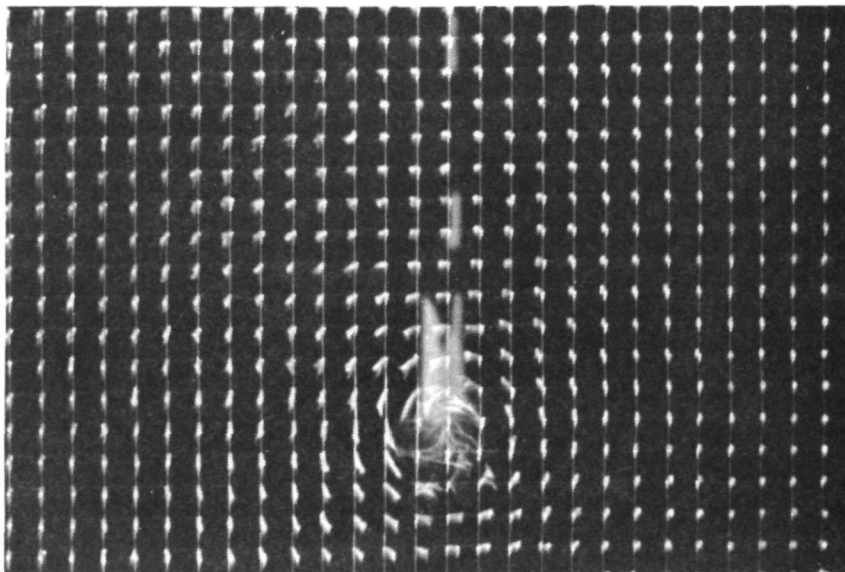

$Z/C = 12.3$

Fig. 18. Tuft Grid Survey, $Q = 5.0'' \text{ H}_2\text{O}$, Moderate Blowing,
 $Z/C = 3.4, 12.3, 20.0, 28.5.$

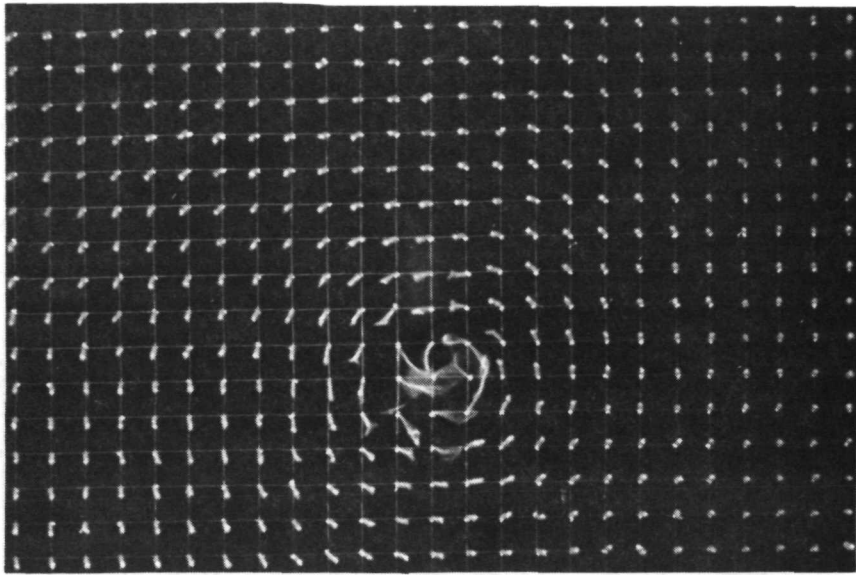

$Z/C = 20.0$

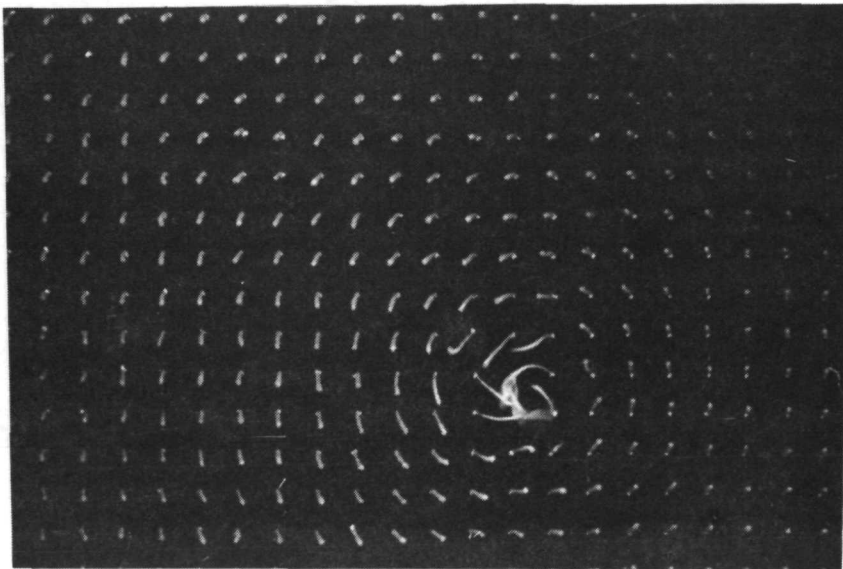

$Z/C = 28.5$

Fig. 18. Continued.

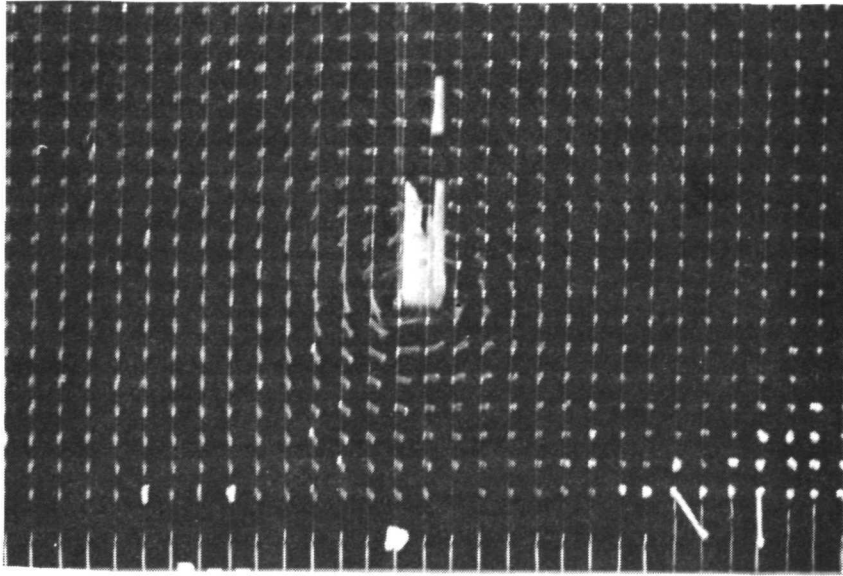

$Z/C = 3.4$

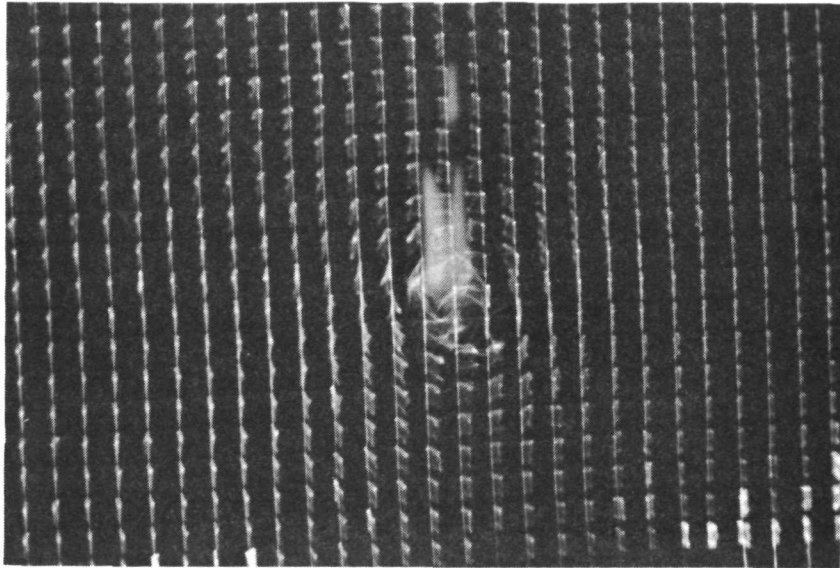

$Z/C = 12.3$

Fig. 19. Tuft Grid Survey, $Q = 5.0'' \text{ H}_2\text{O}$, Full Blowing,
 $Z/C = 3.4, 12.3, 20.0, 28.5.$

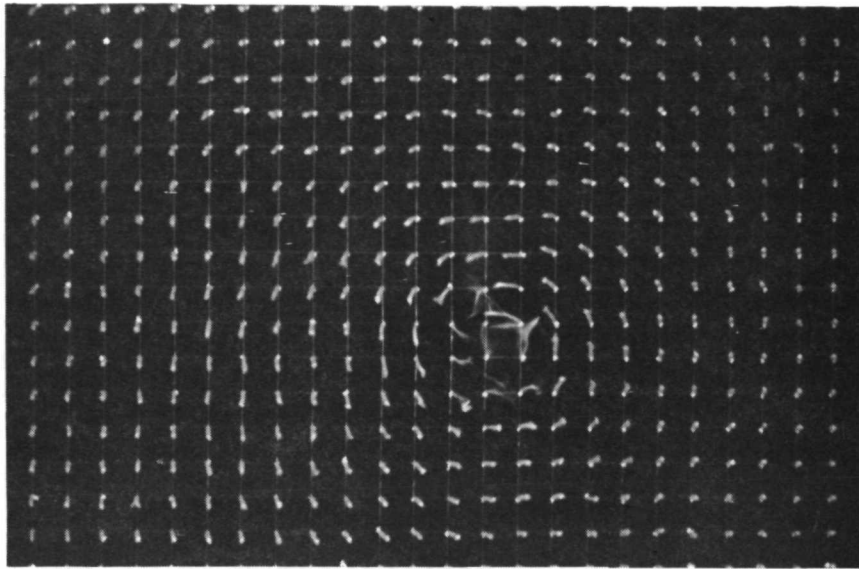

$Z/C = 20.0$

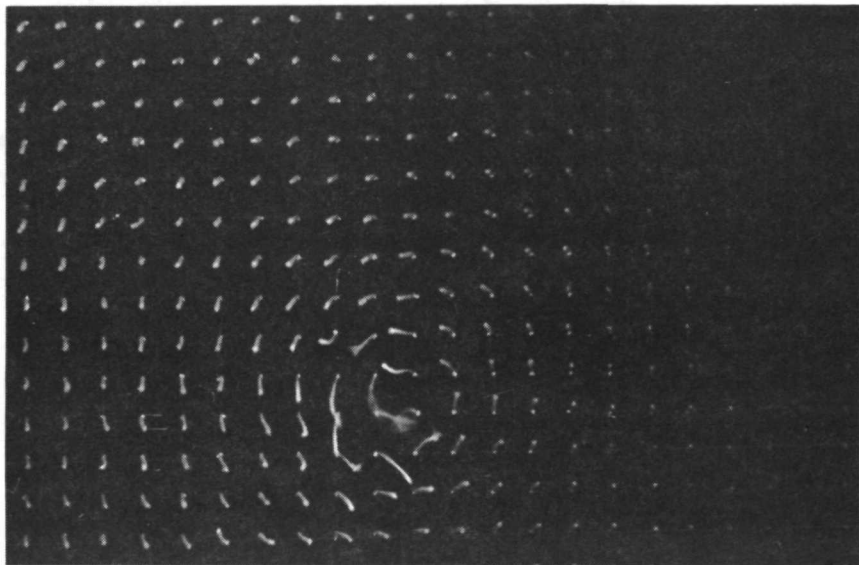

$Z/C = 28.5$

Fig. 19. Continued.