

NEUTRON SPECTRAL MEASUREMENTS IN THE UPPER ATMOSPHERE¹

W. Zobel
T. A. Love
J. T. Delorenzo
C. O. McNew

Oak Ridge National Laboratory
Oak Ridge, Tennessee 38930

An experiment to measure neutrons in the upper atmosphere has been performed on a balloon flight from Palestine, Texas, at an altitude of about 32 km. The experimental arrangement is discussed briefly, and results of a preliminary analysis of the data for neutrons in the energy range 3 to 30 MeV are given.

The decay of neutrons, produced by the interaction of cosmic rays in the atmosphere and subsequently leaving it (so-called "cosmic-ray albedo neutrons"), was suggested initially by Singer (ref. 1) as a mechanism to explain the observed protons in the Van Allen belt. Hess et al. (ref. 2) had measured the spectrum of neutrons in the atmosphere, and these measurements were used as the basis for subsequent calculations designed to test the "Cosmic-Ray Albedo Neutron Decay" (CRAND) theory (refs. 3-5). Additional measurements of neutrons (refs. 6-9) at high altitudes appeared to confirm the spectrum to about 20 MeV since calculated extrapolations from these measurements agreed with the calculated leakage flux of Newkirk (ref. 4) and Lingenfelter (ref. 5) which use the measurements of Hess et al. (ref. 2). Note that the experiments referenced in 6-9 arrive at the "spectrum" by assuming a spectral shape and converting it into the measured quantity, either pulse-height spectra (refs. 6-8) or count rate (ref. 9).

Calculations of the proton injection into the belt from CRAND neutrons by Dragt et al. (ref. 10) using Lingenfelter's estimate for the neutron source, indicated, however, that the CRAND source is too small by a factor of 50 for particles with energies greater than about 20 MeV. Later measurements of the proton spectrum in the belt for protons above 10 MeV appear to confirm this discrepancy (refs. 11-12). While a recent paper by Farley et al. (ref. 13) goes far toward resolving the

discrepancy, it too uses Lingenfelter's spectrum with the observation that experimental verification of this spectrum for energies above 10 MeV is lacking.

It is unfortunately true that the measurements by Hess et al. were performed with counters which had minimal sensitivity in the energy region from roughly 10 to 100 MeV. It is in this very region that the greatest discrepancies are observed. A program was therefore started in 1966 at the Oak Ridge National Laboratory to reduce the uncertainty in the neutron spectrum at high altitude in the energy region from 2 to 60 MeV, the upper limit being chosen because of the availability of detector calibration facilities to this energy, and the lower limit following from the experimental scheme employed. The data-gathering program culminated in a balloon flight on 17 June 1969 from Palestine, Texas. The device floated at an altitude of $31,950 \pm 200$ m (corresponding to about 9 g/cm^2 residual atmosphere) for about 9-1/2 hours. This paper will describe the instrument used and give the results of a preliminary analysis of the data obtained from this flight.

The heart of the spectrometer is a liquid scintillator (Nuclear Enterprises Inc. NE-213) in which neutron interactions are detected by measuring the light pulses produced by recoil protons. Gamma-ray interactions in the scintillator result in pulses which can be separated with pulse-shape discrimination (PSD) techniques. Since incident charged particles can give rise to pulses similar to those from neutron interactions in the detector, the latter is enclosed in a plastic scintillator "mantle" of NE-110 (Nuclear Enterprises, Inc., San Carlos, California). The output from this

¹Research funded by the U. S. Atomic Energy Commission under contract with Union Carbide Corporation; flight costs and telemetry support provided by the NASA Office of Space Science and Applications and the George C. Marshall Space Flight Center.

"mantle" is usually put in anticoincidence with the output from the liquid scintillator, thus preventing any counts due to events which trigger both detectors. The arrangement used is shown in figure 1. The NE-213 is contained in an aluminum can which is mounted on an RCA Type-8575 photomultiplier tube. The mantle is also viewed by an 8575 tube. At the bottom of the assembly can be seen the preamplifier used with the NE-213 detector and the high-voltage power supplies for both tubes. The can shown on the left is 1/16-in.-thick aluminum, used as a pressure vessel to maintain the assembly at ground pressure to eliminate high-voltage sparking. The aluminum can was then surrounded by about 1-1/2 in. of foam insulation to maintain proper operating temperature in the assembly.

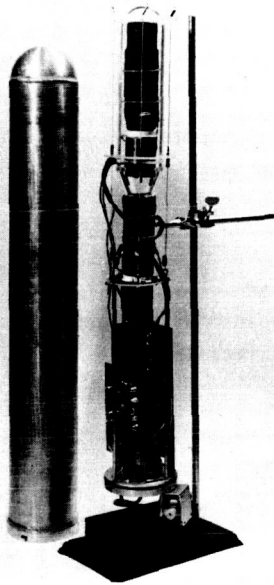

FIGURE 1.— Detector Assembly.

In order to reduce locally produced background, we decided to lower the detector assembly after launch about 90 ft below the gondola on which were mounted the electronics and batteries as well as miscellaneous support equipment. Since it was impractical to retract the detector assembly to the gondola prior to landing, the foam insulation was in turn contained in a 16-gauge sheet-steel can designed to take the landing impact. Proof of the effectiveness of this arrangement was obtained when we recovered the equipment and it showed no deterioration in performance.

A block diagram of the electronics used in this experiment is shown in figure 2. Two functions must be distinguished: pulse-shape discrimination, and pulse-height analysis.

As can be seen from figure 2, the pulse-height analysis was conventional. The major item of note here is that the discriminators had their thresholds adjusted so that the pulse height to be analyzed was determined by the threshold of the zero-crossing discriminator.

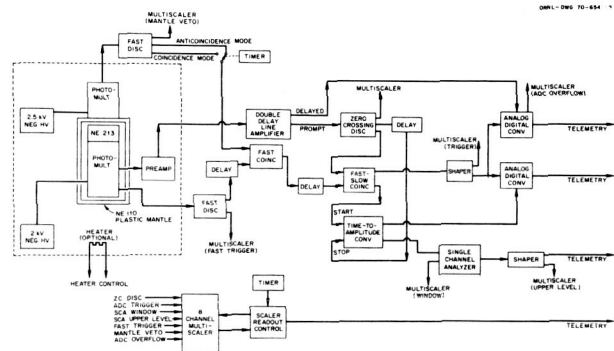

FIGURE 2.— Block Diagram of the Electronics.

The pulse-shape discrimination was based on the difference in the base-line crossing time of the amplifier output pulses due to the different relative amounts of slow light output from proton and electron recoils. The crucial feature of such a scheme lies in the proper adjustment and stability of the timing involved. The time of an event was determined by the input signal to the fast discriminator connected to the NE-213 photomultiplier, and this signal eventually was used as the start signal to the time-to-amplitude converter (TAC). The TAC stop signal was provided by the zero crossing discriminator after an arbitrary delay chosen so as to put the desired signals into the middle of the TAC range.

The TAC output was also digitized in a separate analog-to-digital converter (ADC); in addition, a single channel analyzer used the TAC output to set a bit in the telemetry whenever the TAC signal exceeded a predetermined level corresponding to pulses due to incident neutrons. For each event, then, the output to the telemetry consisted of the output from the two ADC's and two flags, one to identify the PSD ADC and the other to distinguish neutrons from gamma rays. A separate telemetry channel carried the information from the 8-channel multi-scaler shown; yet another telemetry channel, not shown, carried housekeeping information such as pressures, voltages, and temperatures.

A preliminary analysis of the data has been performed, based on the hardware-set bias for the pulse-shape discrimination. A pulse-height spectrum of the events so ascribed to incident neutrons is shown in figure 3. While a few pulses can be seen extending to about channel 230 (corresponding to ~ 50 MeV incident neutrons), most of the spectrum lies below channel 130, or about 30 MeV.

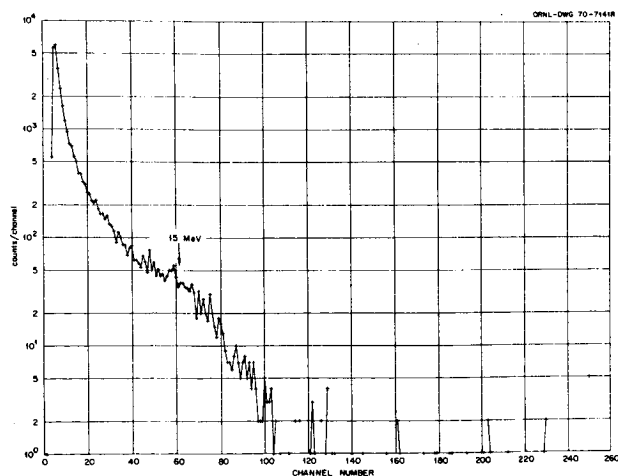

FIGURE 3.— Pulse-Height Spectrum from Neutron Events.

The analysis performed on these data makes use of the calibration of a similar NE-213 detector by Verbinski et al. (ref. 14) and a spectrum unfolding scheme due to Burrus (ref. 15). The calibration of the detector was extended to about 40 MeV (ref. 16), and a slightly different version of the unfolding code (i.e., FERD rather than FERDor) was employed. The results of this analysis are shown in figure 4. Also shown on the figure are the results of the group at New York University (ref. 8) in the 2 to 10 MeV energy range.

Several points must be made in connection with this figure. The first and most important is that it is still preliminary; for example, no attempt has been made to estimate in any detail the required correction for locally produced background neutrons. A very crude, zeroth-order calculation indicates that such a correction should not amount to more than 25% of the total number of counts observed, but no detailed calculation to determine the spectral shape of this correction has yet been

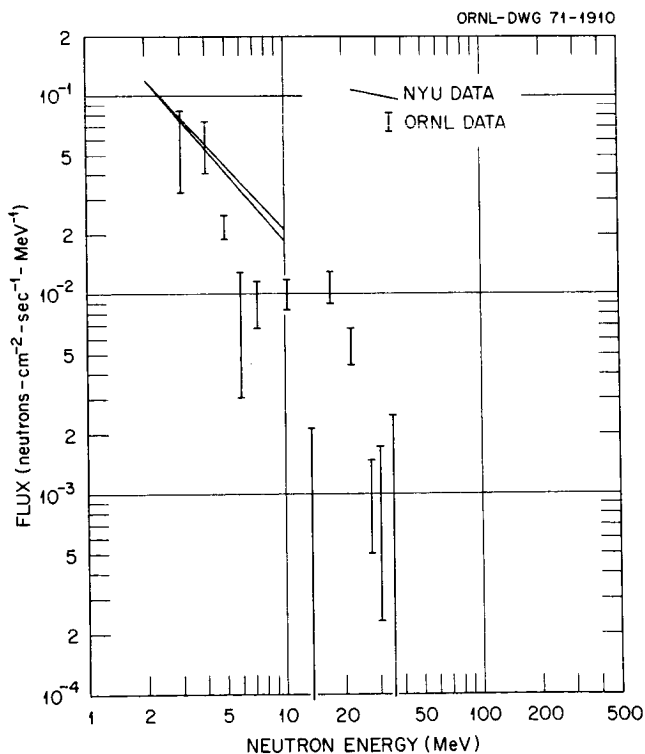

FIGURE 4.— Neutron Energy Spectrum at ~ 9 g/cm² Between 95.5° - 100.7° W, and 31.3° - 31.8° N.

performed. A second point to note is that the analysis procedure results only in the determination of a 68% confidence interval within which the result can be expected to lie. It is for this reason that no data points are shown but only the limits of this confident interval. The width of the interval is due not only to the statistical deviations expected from the input data but also includes the uncertainties associated with the unfolding process except those associated with the response matrix. For the comparison with the NYU data it must be remembered that their data were obtained during a period of solar minimum, whereas our data were taken during solar maximum. One would, therefore, expect their results to lie above ours, by perhaps 25%.

A comparison with the calculations of Lingenfelter is best accomplished by comparing our results with his in the form of an integral over a common energy region. Part of his calculations yield $0.106 \text{ neutrons-cm}^{-2}\text{-sec}^{-1}\text{-MeV}^{-1}$ for the integrated flux from 3.16 to 10 MeV at 8 g/cm^2 residual atmosphere for 40° geomagnetic latitude

(ref. 17). Our preliminary data, integrated from 3 to 10 MeV for 9 g/cm^2 residual atmosphere at about 41° latitude give an upper limit of 0.155 and a lower limit of $0.142 \text{ neutrons/cm}^{-2}\text{-sec}^{-1}\text{-MeV}^{-1}$.

Further analysis of the data, as well as an attempt to calculate the neutron spectrum to be expected, is in progress.

We wish to gratefully acknowledge the vital contribution to the project made by Mr. H. W. Parker and his associates from George C. Marshall Space Flight Center, who furnished and operated the telemetry equipment, and, of course, the invaluable cooperation of the personnel at the NCAR Scientific Balloon Facility, Palestine, Texas, who conducted the launch, flight, and recovery operation. Mr. R. H. Baldry, formerly with the Laboratory, designed and supervised construction of the necessary interfacing to the telemetry equipment. Thanks are also due Dr. R. B. Mendell of New York University for making available their data prior to publication, and to Dr. R. E. Lingenfelter for use of his unpublished results.

REFERENCES

1. SINGER, S. F.: Phys. Rev. Letters, vol. 1, 1958, p. 171, 181.
2. HESS, W. N.; PATTERSON, H. W.; WALLACE, R.; and CHUPP, E. L.: Phys. Rev., vol. 116, 1959, p. 445.
3. HESS, W. N.: Phys. Rev. Letters, vol. 3, 1959, p. 11.
4. NEWKIRK, L. L.: J. Geophys. Res., vol. 68, 1963, p. 1825.
5. LINGENFELTER, R. E.: J. Geophys. Res., vol. 68, 1963, p. 5633.
6. MENDELL, R. B.; and KORFF, S. A.: J. Geophys. Res., vol. 68, 1963, p. 5487.
7. HAYMES, R. C.: J. Geophys. Res., vol. 69, 1964, p. 841.
8. MENDELL, R. B.: private communication.
9. Boella, G.; ANTONI, G. D.; DILWORTH, C.; PANETTI, M.; SCARSI, L.; and INTRILIGATOR, D. S.: J. Geophys. Res., vol. 70, 1965, p. 1019.
10. DRAGT, A. J.; AUSTIN, M. M.; and WHITE, R. S.: J. Geophys. Res., vol. 71, 1966, p. 1293.
11. IMHOF, W. L.; and REAGAN, J. B.: J. Geophys. Res., vol. 74, 1969, p. 5054.
12. FARLEY, T. A.; TOMASSIAN, A. D.; and CHAPMAN, M. C.: J. Geophys. Res., vol. 74, 1969, p. 4721.
13. FARLEY, T. A.; TOMASSIAN, A. D.; and WALT, M.: Phys. Rev. Letters, vol. 25, 1970, p. 47.
14. VERBINSKI, V. V.; BURRUS, W. R.; LOVE, T. A.; ZOBEL, W.; HILL, N. W.; and TEXTOR, R.: Nucl. Instr. Methods, vol. 65, 1968, p. 8.
15. BURRUS, W. R.; and VERBINSKI, V. V.: Nucl. Instr. Methods, vol. 67, 1969, p. 181.
16. COHEN, L. D.; LOVE, T. A.; SANTORO, R. T.; WACHTER, J. W.; and ZOBEL, W.: Calibration of an NE-213 Detector with 40-MeV Neutrons. Neutron Phys. Div. Ann. Progr. Rept. May 31, 1969, Oak Ridge National Laboratory Document ORNL-4433, 1969, p. 108.
17. LINGENFELTER, R. E.: private communication.