

CR115427

**SPACE SHUTTLE
LOW COST/RISK
AVIONICS STUDY**

**FINAL REPORT
12 November 1971**

**CASE FILE
COPY**

**B35-43RP-26
CONTRACT NAS 9-11160
MODIFICATION 9S**

**GRUMMAN
BOEING**

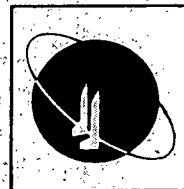

**SPACE SHUTTLE
LOW COST/RISK
AVIONICS STUDY**

**FINAL REPORT
12 November 1971**



GRUMMAN/BOEING

GE

PHILCO FORD

RCA

INTERMETRICS

RADIATION, INC.

SPERRY

HAMILTON STANDARD

LITTON

BENDIX

EASTERN AIRLINES

PROGRAM

DEVELOPMENT SCHEDULE

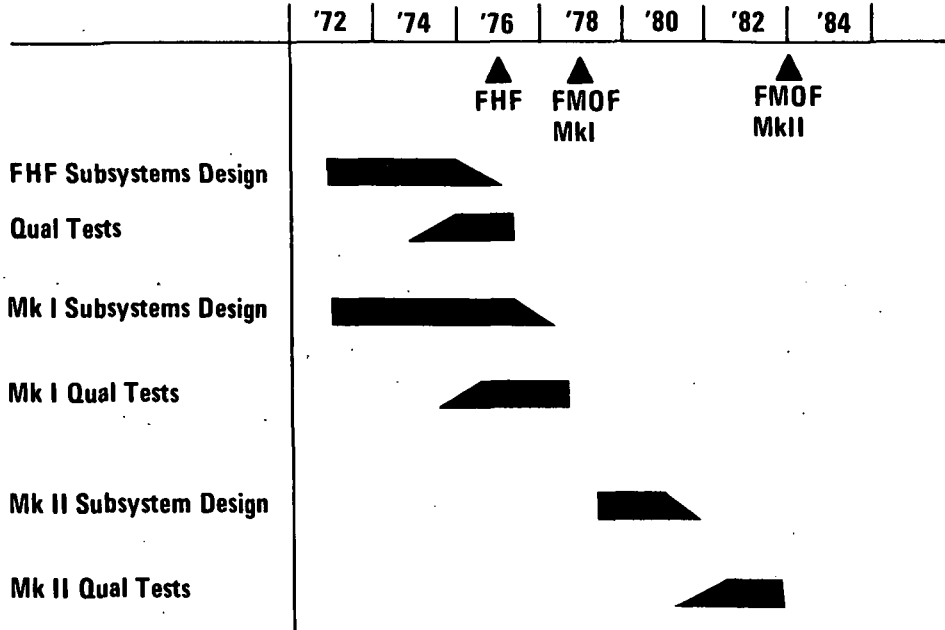

For the purpose of pricing the life cycle costs of the low cost avionics system, we examined all Work Breakdown Structure elements that contain any avionics related effort.

In addition to the basic "onboard" avionics and electrical power systems, the vehicle WBS includes the analytical, testing, and integration effort for these systems. The design and procurement of special test equipment and maintenance and repair equipment is included in Systems Support.

The Program Management associated with the above efforts has also been included.

The Flight Test WBS includes flight test spares and all labor and materials associated with the operations and maintenance of the avionics systems throughout the horizontal flight test programs.

Operations includes the same type of effort for the operational phase based on the traffic model specified by Technical Directive GAC-4.

SHUTTLE AVIONICS WBS

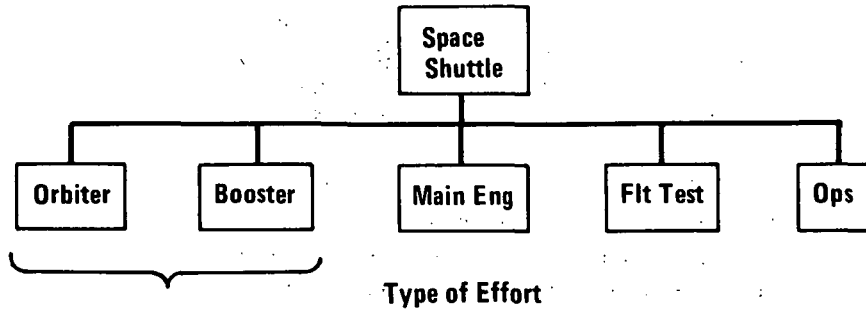

- Avionic Hardware
- On-Board Software
- Elect. Pwr System
- Systems Integration
- Systems Engineering
- Systems Support
- Management
- *Other Subsys Interfaces*

- Maintenance
- Spares
- Flt Test Support
- Data Acquisition
- Data Reduction

- Maintenance
- Spares
- Launch Support
- Mission Support
- Data Acquisition
- Data Reduction

To provide NASA with costs which may be compared between contractors and between alternate configurations, we made every attempt to standardize costing "ground rules" and assumptions.

The accompanying table summarizes the key assumptions that were used.

These ground rules and the program master and sub system schedules were supplied to the subcontractors who estimated specific equipment, to assure uniformity of response.

Several subcontractors indicated that there could be substantial savings realized through a learning curve, but this impact cannot be assessed at the present time.

KEY COSTING ASSUMPTIONS

- **Constant 1970 Dollars**
- **No Learning Curve**
- **Cost Through G&A - No Fee/Profit Included**
- **Fleet Size - Orbiter 2 + 3 Booster 2 + 2**
- **Traffic Model per Tech Directive GAC-4**
- **Commonality - Development Charged to Orbiter
- Hardware to Each Vehicle**
- **Detail Costs for Recommended Configuration Only**

The costs of the hardware for the first two flight articles are included in the Mk I column for the orbiter and the DDT&E column for the booster.

Orbiter Mk II includes only those development changes for the additional or unique Mk II hardware and software.

“Production” includes the costs associated with the 3rd, 4th, and 5th orbiter, and 3rd and 4th Flyback booster. In the case of the orbiter it includes the Mk II hardware for these three vehicles, but not the retrofit Mk II hardware for the first two flight articles. (Retrofit costs have been included in this study in another WBS, and do not appear on this chart.)

LOW COST AVIONIC EQUIPMENT, \$M

	Orbiter DDT&E		Prod.	Flyback Booster		Ballistic Booster	
	Mk I	Mk II		3 Veh	DDT&E	Prod.	DDT&E
			2 Veh		46 Veh		
GN&C	40.1	—	15.1	26.2	6.8	}	67.1
Data Mgmt	23.6	—	11.1	4.7	1.1		
Instrumentation	22.2	—	6.5	12.5	7.6		
Telecom	12.6	6.3	11.8	1.1	0.5		
Displays & Controls	31.7	5.0	13.7	6.2	3.0		
Subsys Integ	24.9	—	18.3	3.5	1.9		
Software	36.7	10.7	—	6.7	0.4		
Total Avionics	191.8	22.0	76.5	60.9	21.3	3.7	67.1
Elect. Power	71.2		17.5	59.0	10.0	.5	.6
(Subtotal)	285.0		94.0	119.9	31.3	4.2	67.7
Total Vehicle	379.0			151.2		71.9	



This chart summarizes the "onboard" hardware and software costs.

Alternate booster configurations are shown. The orbiter configuration is the same for either booster. Both development and production costs are shown for both vehicles.

Comparison has been made with the Phase B baseline. This base line has been adjusted from the final report to reflect the addition of the fifth orbiter and fourth booster.

LOW COST AVIONICS AND PWR COSTS - DDT&E/PROD

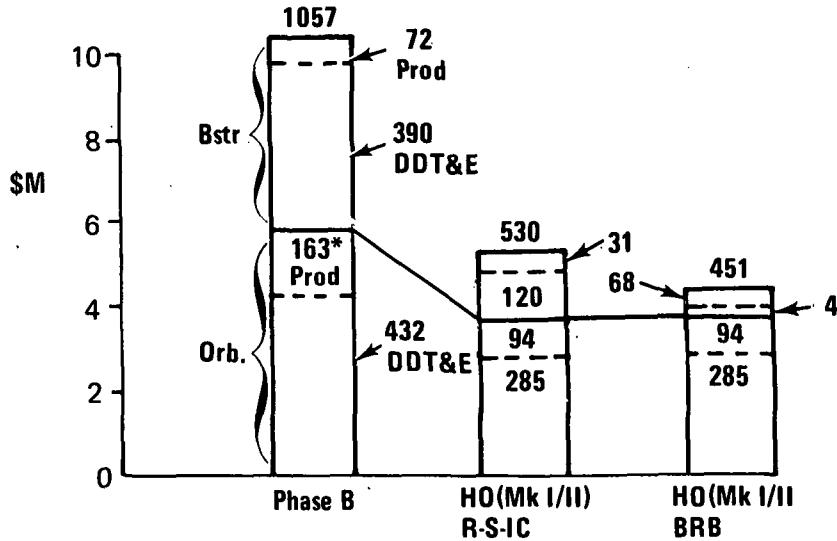

*Adjusted for Three (3) Production Orbiters.



This chart compares the low cost avionics configuration to the Phase B on an annual funding basis.

To achieve a better comparison, the Phase B baseline Option A was respread to conform to the present program schedule. This respread shows the "double hump" characteristic of the Mk I/Mk II concept with delayed production articles.

The total area under the curve is that shown in the previous chart.

LOW COST AVIONIC AND POWER ANNUAL FUNDING

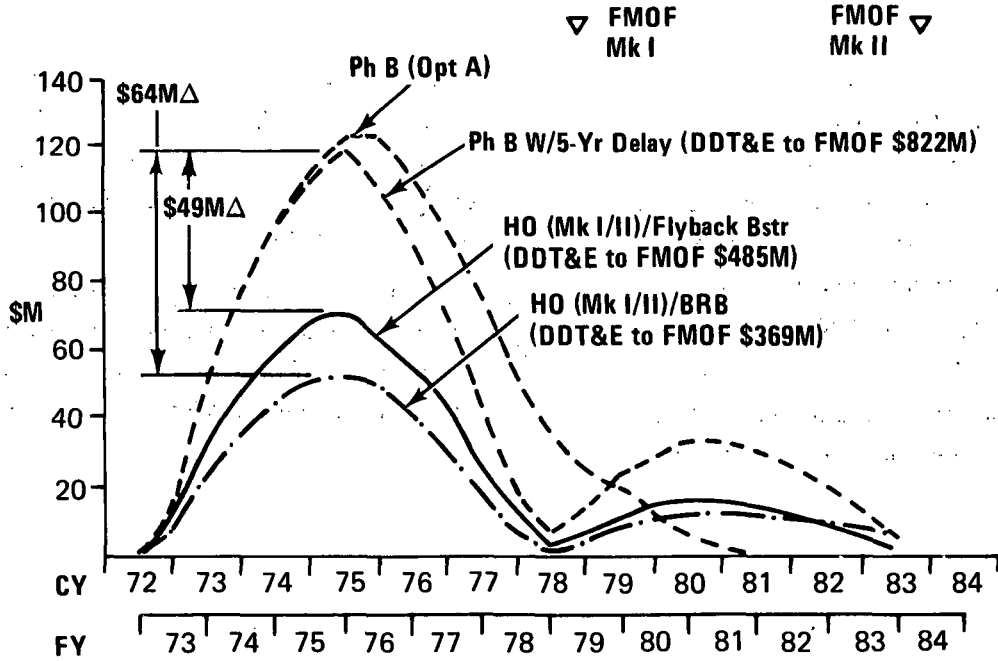

The weight increase of the low cost-risk avionics over the Phase B avionics is due to the use of existing hardware, dedicated computers (aero-flight control, air data, primary and data acquisition controller), conventional power conditioning and distribution, and data busing for data acquisition only. In addition, degraded and dissimilar backup capability has been provided.

The R-SI-C booster avionics utilizes much of the same hardware as the orbiter to take advantage

of the cost savings achieved by commonality. The higher booster weights are due to the additional surface controls, the stability augmentation, the greater number of air breathing, and rocket engines required for a larger vehicle.

The BRB avionics is a reduced complement of equipment because it is unmanned and recovered in the ocean. An additional 75 lb of avionics onboard the orbiter is required to interface with the BRB.

WEIGHT COMPARISON, MK I

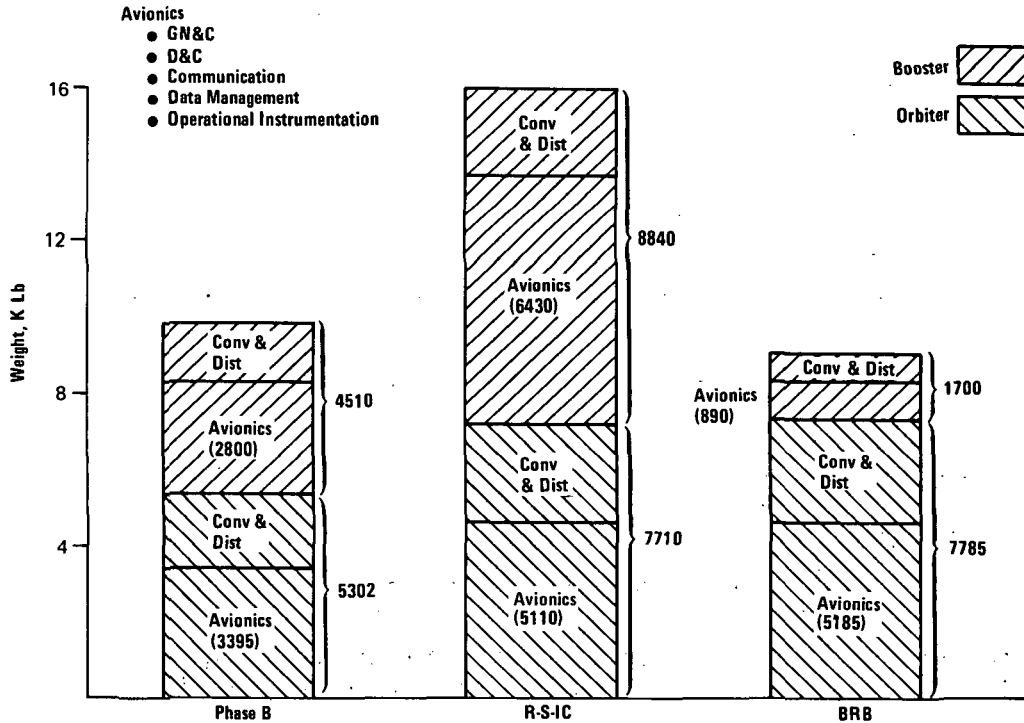

WHAT DID WE LEARN?

Cost Savings Can Be Achieved By:

- **Using Existing Hardware to**
 - **Reduce Cost Risks**
 - **Reduce Developmental Costs**
 - **Achieve Production-Run Cost Breaks**
 - **Minimize Support Costs for Life of Equipment**
- **Maximizing Orbiter-Booster Commonality**
- **Specifying New Equipments to MIL Quality Standards**
- **Basing Redundancy on Cost Effective Analysis**
- **Minimizing Software Complexity-Reduce Cross Strapping & Computer-Managed Functions**
- **Utilizing Compilers & Floating Point Computers**
- **Evolving the Design as Dictated by the Horizontal Flight Test, Mk I and Mk II Schedules**

Peak Funding Reqmts can be Minimized by Growing the System Capability From That Needed for Horizontal Flight Test Reqmts Through Mk I & Mk II.

UNMANNED FLIGHT TEST

OBJECTIVE: Man Rate Vehicles for Vertical Flight Test Program

MISSION PHASES: Boost, Orbit, Reentry, Landing

ASSUMPTIONS & GROUND RULES:

- **Minimum Impact to Mk I Hardware**
- **All Objectives Can Be Accomplished in One Orbit**
- **Unmanned Landing Capability Demonstrated in Horizontal Flight Test Program**
- **No Special Ground Tracking or Support Equipment Required**
- **No Single Failure Shall Result in Mission Failure**
- **Weight is Not Constraint**
- **Launch at Cape Kennedy**
- **Landing Site Restricted to Edwards or White Sands for the Orbiter**
- **Launch Abort Requires Range Safety Destruct**

The block diagram shows the unmanned flight hardware required and how it interfaces with the Mk I avionic equipment. The switching functions are provided by two Program Couplers similar to the Program Coupler developed for the unmanned LM flights. The two couplers provide a total capability of 256 switching functions which is adequate for the presently identified 208 functions plus some growth capability. The Program Couplers are essentially relay matrices controlled either by an automatic sequence under computer control or by direct commands via uplink from the ground. One coupler is provided for the switching functions associated with the space portion of the flight and is under direct control using the existing S-band command link. The second coupler provides the switching functions associated with the atmospheric portion of the flight and is under direct control of a UHF command link provided especially for the unmanned flight.

A remote control coupler has been provided

in order to obtain remote flight control capability during the atmospheric portion of the flight. The coupler receives commands from the computer for automatic flight control and from the UHF command link for remote control. The remote control coupler provides commands to the aerodynamic flight control computer and the auto throttle and auto braking electronics to control the vehicle.

A Range Safety Receiver and Decoder is provided to activate a destruct system which will destroy the vehicle upon ground command. This system must be secure in order to prevent accidental activation but must also be reliable to insure operation in the event of an emergency.

The booster modifications necessary for an unmanned flight are essentially the same as for the aerodynamic portion of the orbiter system. The lower half of the diagram defines the avionics changes necessary for unmanned booster flight .

UNMANNED FLIGHT CONFIGURATION BLOCK DIAGRAM

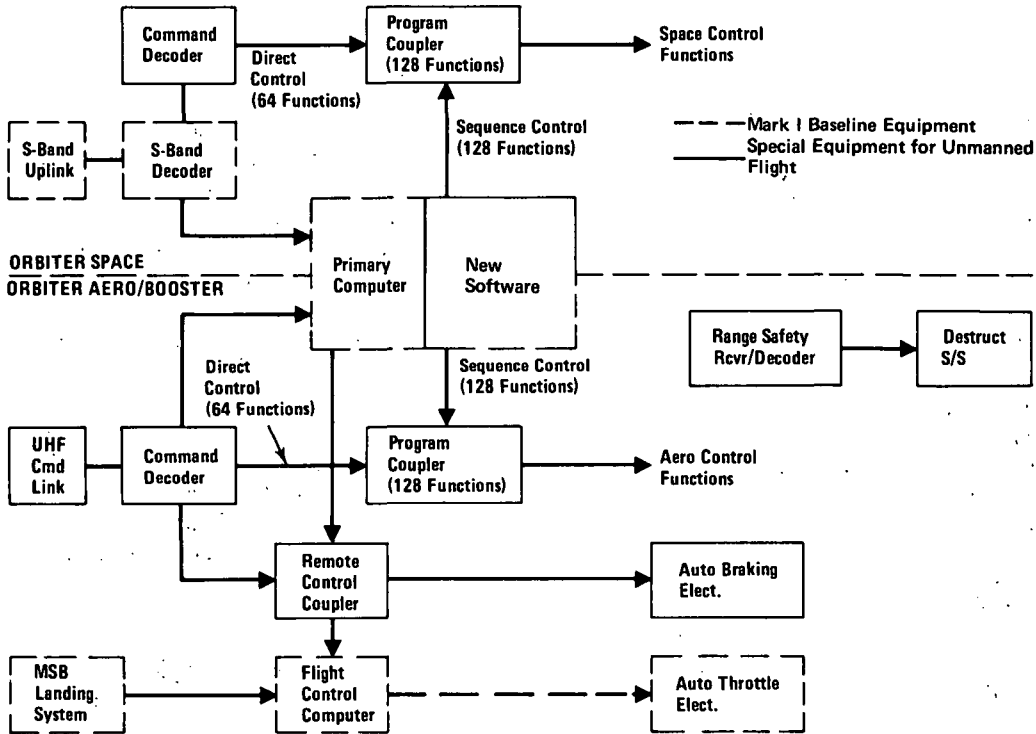

This chart time phases the delta costs associated with an unmanned launch of the orbiter.

The higher cost curve represents an unmanned orbiter launched with a flyback booster which is also assumed to be unmanned. The lower curve represents an unmanned orbiter launched with a ballistic booster which, by definition, is designed to be unmanned.

Note that these costs cover only the "on board" "black boxes" associated with unmanned flight. Launch, ground tracking, and automated landing complexities have not been costed for either hardware or software impact.

The additional hardware for the unmanned configuration has been estimated based on similar developments on other programs. The following table gives a breakdown for the orbiter and booster modifications.

Orbiter

- Program Coupler - 4 sets
- Digital Command Decoder - 3 sets
- UHF Command Link - 2 sets
- Auto Throttle Electronics - 2 sets
- Auto Braking Electronics - 2 sets
- Power Distribution Panel - 1 set
- Cable Set - 1 set
- Remote Control Coupler - 2 sets
- Range Safety Destruct System - 1 set

Booster

- Program Coupler - 2 sets
- Digital Command Decoder - 2 sets
- UHF Command Link - 2 sets
- Auto Throttle Electronics - 2 sets
- Auto Braking Electronics - 2 sets
- Power Distribution Panel - 1 set
- Cable Set - 1 set
- Remote Control Coupler - 2 sets
- Range Safety Destruct System - 1 set

UNMANNED VERTICAL FLIGHT TEST

Considerations Not Costed:

- Cable Interface Technique
- Landing Site Requirements
- Remote Landing Technique
(Ground Control vs Chase Plane)

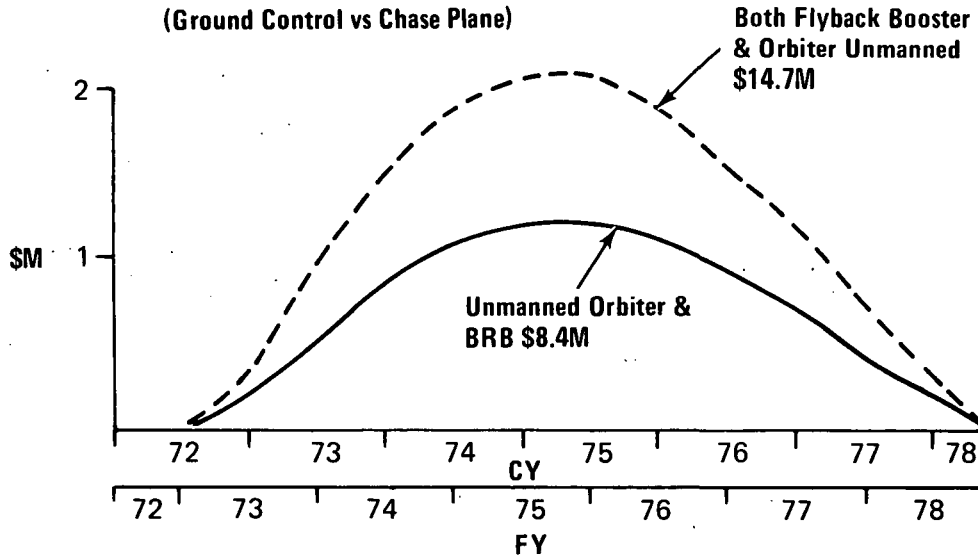

The Grumman/Boeing Low Cost/Risk Avionics accomplished the separation of functions by selection of dedicated hardware for many critical functions rather than the adoption of a complete inflexible "firewall" approach. Physical separation into two dedicated crew stations was considered but discarded in favor of selective functional separation. This permits the retention of an economical two-man crew, without relinquishing the essential backup they provide for each other.

A sharp cleavage is maintained, however, throughout the Avionics Subsystems between the aircraft and spacecraft equipment mechanization, through the use of separate dedicated systems. This approach permits FHF and subsequent early flight

tests to proceed without being saddled with the necessity of providing, and operationally maintaining, an additional complex spacecraft system with accompanying software not relevant to this portion of the test program. As indicated, the primary flight controls, communications and landing aids are served by separate equipments. The Power Distribution Conditioning and Control, battery, data acquisition, some G&N common mode functions such as the IMU, primary computer and the associated display and control functions are common for both flight regimes. Major deviations from the separation concept include the use of a modified conventional aircraft electro-mechanical FDAI display to include a spacecraft attitude display mode and also the dual purpose use of the sidarm controllers.

ORBITER SEPARATION OF FUNCTIONS MK I - LOW COST/RISK SYSTEM

Subsys	Airplane	Common	Spacecraft
Flight Control	<ul style="list-style-type: none"> ● Dedicated Aero Digital Autopilot ● Elect. Backup System ● ABES Control Elect. 		<ul style="list-style-type: none"> ● Dedicated Spacecraft Digital Autopilot ● ACPS, OMS, MPS Control Elect.
Guid & Nav	<ul style="list-style-type: none"> ● Subsonic Air Data Sensors/ Computer ● AHRS (FHF only) 	<ul style="list-style-type: none"> ● MSFN ● IMU ● Pri Computer ● TACAN 	<ul style="list-style-type: none"> ● Hypersonic Air Data Sensors ● Optical Tracker

ORBITER SEPARATION OF FUNCTIONS MK I- LOW COST/RISK SYSTEM (Cont)

Subsys	Airplane	Common	Spacecraft
Telecom & RF Aids	<ul style="list-style-type: none"> ● UHF-ATC ● Microwave Scanning Beam 		<ul style="list-style-type: none"> ● USB
Displays & Controls	<ul style="list-style-type: none"> ● Dedicated ABES, APU, Caution & Warning, MSB, C-Band Altimeter 	Displays & Control <ul style="list-style-type: none"> ● Primary Flight ● ECLS ● Pwr Dist 	<ul style="list-style-type: none"> ● Dedicated OMS, ACPS, MPS, Fuel Cells, Caution & Warning.
Data Mgmt		<ul style="list-style-type: none"> ● Data Acq 	
Elect. Power	<ul style="list-style-type: none"> ● APU-Generator 	<ul style="list-style-type: none"> ● Power Distribution, Conditioning & Control ● Battery 	<ul style="list-style-type: none"> ● Fuel Cells

The present baseline achieves lower program cost/risk than our Phase B configuration by reducing the onboard equipment complexity through a more judicious mix of ground and vehicle task responsibility assignment. Increased reliance on the ground mission control center for mission and systems management and a more active role in spacecraft navigation functions relieves some of the higher cost associated with developing complete vehicle autonomy. Similarly, detailed checkout, troubleshooting, and trending is assigned to the vehicle launch center.

Onboard, the system control is primarily relegated to manual tasks, with automation retained basically only for time critical reconfiguration requirements.

ORBITER ON-BOARD FUNCTIONAL CAPABILITY SUMMARY

Function	Phase B	Low Cost/Risk System		
		FHF	Mk I	Mk II
Mission Mgmt	<ul style="list-style-type: none"> ● Primarily Autonomous 	None	<ul style="list-style-type: none"> ● Primarily Ground 	<ul style="list-style-type: none"> ● Crew Scheduling ● Contingency Planning ● Reentry Scheduling
Systems Mgmt	<ul style="list-style-type: none"> ● Checkout to LRU ● Automatic Reconfig 	<ul style="list-style-type: none"> ● Caution & Warning ● Manual Reconfig ● Manual Subsystem Control 	<ul style="list-style-type: none"> ● Caution & Warning ● Manual Reconfig ● Manual Subsystem Control 	<ul style="list-style-type: none"> ● Checkout to LRU ● Computer aided Re-config & Subsystem Control
Flt Dyn Mgmt (Guidance)	<ul style="list-style-type: none"> ● Primarily Autonomous 	<ul style="list-style-type: none"> ● Autonomous Attitude & Heading only 	<ul style="list-style-type: none"> ● Ground Update 	<ul style="list-style-type: none"> ● Primarily Autonomous



ON-BOARD FUNCTIONAL CAPABILITY SUMMARY (Cont)

Function	Phase B	Low Cost/Risk System		
		FHF	Mk I	Mk II
Displays & Controls	<ul style="list-style-type: none"> ● Multi-Purpose Displays, Manual Entry Keyboards, Side Arm Controllers 	<ul style="list-style-type: none"> ● Dedicated Aero D&C ● Multi-Func Side Arm Controllers 	<ul style="list-style-type: none"> ● Dedicated Aero & Space D&C ● Multi-Func Side Arm Controllers 	Same as Mk I Plus <ul style="list-style-type: none"> ● Multi-Purpose OBC-CRT Display
Data Acquisition	<ul style="list-style-type: none"> ● Multiplexed Data & Command Bus 	<ul style="list-style-type: none"> ● Data Acq bus ● GSE data bus 	<ul style="list-style-type: none"> ● Expanded Capacity Data Acq Sys 	Same as Mk I
Tel-metry	<ul style="list-style-type: none"> ● Continuous Gnd link via TDRS 	<ul style="list-style-type: none"> ● Overlay DFI Link 	<ul style="list-style-type: none"> ● Periodic Gnd Link via MSFN 	<ul style="list-style-type: none"> ● Continuous Gnd Link Via TDRS
COMM	<ul style="list-style-type: none"> ● ATC ● Continuous Gnd Link via TDRS ● Intervehicle 	<ul style="list-style-type: none"> ● ATC ● FLT Test Site ● Chase Plane 	<ul style="list-style-type: none"> ● ATC ● Periodic Gnd Link via MSFN 	Same As Phase B

ON-BOARD FUNCTIONAL CAPABILITY SUMMARY (Cont)

Function	Phase B	Low Cost/Risk System		
		FHF	Mk I	Mk II
Flight Controls	<ul style="list-style-type: none"> ● Centralized Multiplexed Fly-By-Wire ● Combined A/C & S/C Computer 	<ul style="list-style-type: none"> ● Dedicated A/C Auto-Pilot, Hardwired ● Independent A/C Electrical Backup 	<ul style="list-style-type: none"> ● Separate A/C & S/C Hardwired Auto-Pilots ● Independent A/C Electrical Backup 	<ul style="list-style-type: none"> ● Same as Mk I
Nav	<ul style="list-style-type: none"> ● Primary Gnd Area Nav & Tracking ● Autonomous Cooperative Rendezvous & Orbital Nav 	<ul style="list-style-type: none"> ● Autonomous Attitude & Heading only 	<ul style="list-style-type: none"> ● Primarily Ground 	<ul style="list-style-type: none"> ● Primarily Ground
Landing	<ul style="list-style-type: none"> ● Autoland 	<ul style="list-style-type: none"> ● VFR Landing 	<ul style="list-style-type: none"> ● Pilot Control Instr Landing 	<ul style="list-style-type: none"> ● Automatic Control Instr Landing



REDUNDANCY

The low cost shuttle avionics system has been based on a fail-safe (FS) configuration as a minimum, in accordance with SOW requirements. Where feasible, degraded backup modes have been utilized to achieve fail-safe capability without the addition of operational redundancy.

The approach used in determining the redundancy levels for the recommended configuration has been as follows:

- A minimum configuration was defined for each subsystem that is fail safe for crew safety equipments (operational or functional redundancy) and single thread for mission success equipments
- Redundancy was added selectively to this minimum configuration where economically justifiable, so as to reduce total program costs. Abort cost savings were traded off against the cost penalty of additional redundancy (weight and equipment penalty costs).

Two models were employed in performing these tradeoffs; a cost-effectiveness model, and a payload effectiveness model. Where the abort cost savings for the program exceeded the costs of the additional redundancy, the decision was made to add the redundancy. Based on these economic criteria, redundancy decisions were made on each equipment

individually, resulting in the addition of redundancy selectively to the minimum configuration. As can be seen by referring to the tables of Equipment Operational Redundancy for each subsystem, in some cases no redundancy was added, in others one or even two equipments were added above that in the minimum (FS) configuration.

Grumman has developed computer programs and nomographs for exercising the Cost and Payload Models, which, in addition to mechanizing the basic calculations, also permit sensitivity analyses and parametric studies to be made in an efficient manner.

The program cost savings for each program phase, (Mk I and Mk II), and each booster (R-S-1C and BRB), were computed for each redundancy level, FS, FO/FS and FO²/FS as well as the selective redundancy established by both the Cost and Payload models as follows:

$$\Delta \text{Savings (from FS)} = \frac{(\Delta \text{No of Aborts})(\text{Mission Cost})}{(\text{No. of Vehicles})} - (\Delta \text{W})(\text{Cost}) - (\Delta \text{Equipment Cost})$$

As shown in subsequent tables, both models resulted in the highest overall program savings, and yielded approximately the same results.

The impact of maintenance costs due to the additional redundancy was also examined during this study and found to have a negligible effect on total program cost savings.

LOW COST AVIONICS STUDY

RELIABILITY REQUIREMENTS

- **Fail-Safe (FS) Configuration Minimum**
 - **Degraded Backup Redundant Modes Permissible**

REDUNDANCY RATIONALE

- **Baseline Subsystem Design Satisfies:**
 - FS Minimum, Worst Mission Phase**
- **Add Redundancy When Economically Justifiable**
 - **Minimize Total Program Costs**
 - o **Savings—Reduce Aborts**
 - o **Penalties—Hardware**
 - Weight
 - Maintenance

Orbiter Cost/Payload Model Parameters

The accompanying table identifies the mission parameters utilized in the cost/payload redundancy selection models. These values utilized in the associated computer programs, i.e., number of vehicles, number of flights, payload weight and mission duration for both the Mk I and Mk II phases of the mission are in accordance with NASA SOW requirements.

Cost sensitivities to weight change and mission costs have been derived based on Operations Analysis considerations as follows:

Weight Cost Sensitivity

The values indicated represent the increase in total program cost for placing into orbit each pound of inert weight added to the orbiter. Consequently, these values are dependent on the phase of the program (e.g., Mk I or Mk II) and the booster employed (R-S-1C or BRB). A fixed payload has been assumed in these calculations, therefore the orbiter must grow for any additional weight added to the vehicle. It should be noted that for the orbiter during the Mk I phase, fixed engines have been assumed, while for the Mk II phase rubberized engines have been

assumed.

Further for the R-S-1C, only the orbiter grows for additional weight added, while for the BRB both the booster and orbiter grow. For the R-S-1C, the weight penalty is not severe, since excess lift capability exists (e.g. R-S-1C is oversized for the orbiter and therefore does not have to grow). For the BRB however, since it is an optimized vehicle, the weight penalty is severe because the BRB must grow (rubberized) to accommodate increased orbiter weight.

Mission Cost

Among the more significant elements of mission costs included in the values indicated for Mk I and Mk II for both boosters are: orbiter/booster fuel; ground operations; MSFN support, and orbiter booster refurbishment (materials + labor) costs.

In addition to normal refurbishment costs, costs associated with orbiter TPS ablatives refurbishment (Mk I only) and BRB recovery and refurbishment such as tank cleaning/valve replacement have been included.

Costs associated with launch delays have not been included in the mission costs.

COST/PAYLOAD MODEL PARAMETERS, ORBITER

	<u>Mk I</u>		<u>Mk II</u>	
No. of Vehicles	2			3 + retrofit 2 Mk I's
No. of Flights	99		346	
Payload, K Lbs	25		65	
Mission Time, Days	7		7	
	<u>R-S-IC</u>	<u>BRB</u>	<u>R-S-IC</u>	<u>BRB</u>
Wt Sensitivity, \$K/Lb	9.0	21.7	16.5	32.4
Mission Cost/Flt (1), \$M	6.6(2)	14.0(2)	4.3	12.0

(1) Includes Orbiter/Booster Fuel & Refurbishment Costs & Mission Operations Costs

(2) Includes Orbiter Ablatives Refurbishment



Additional redundancy shows significant cost savings compared to the baseline minimum configuration (FS). For the Mk I, HO/R-S-1C shuttle system these savings range from \$154M to \$166M. The largest contributor to these savings results from the reduction in anticipated mission aborts (28 for the minimum configuration). While the immediate application of an FO/FS approach provides the reduction, the selective redundancy approach using the Cost Effective Model or the Payload Effective Model further optimizes program costs indicating savings of several million dollars.

As might be anticipated, the additional redundancy significantly enhances crew safety reliability, RCS as well as providing the improvement in mission success, RMS.

REDUNDANCY SELECTION TRADEOFF, Mk I, HO/R-S-IC

	R_{CS}	R_{MS}	No. of Aborts	ΔWt/ Veh, Lb	ΔEq Cost/ Veh, \$M	Cost Savings, \$M
Min Config (FS)	.99427	.71939	27.8	—	—	—
Cost Model	.99997	.99824	0.2	1415	1.60	166
Payload Model	.99984	.98234	1.7	720	1.23	163
FO/FS	.99977	.99054	0.9	1305	1.39	163
FO²/FS	.99999	.99954	0.1	2611	2.78	154

$$\Delta \text{Savings (From FS)} = (\Delta \text{ No. of Aborts}) (\text{Mission Cost}) - (\Delta W) \left(\frac{\text{Cost}}{\text{Lb}} \right) - (\Delta \text{ Eq Cost}) (\text{No. of Vehicles})$$

R_{MS} = Probability of Mission Success

R_{CS} = Probability of Crew Survival

The Mk II, HO/R-S-1C shuttle system has even greater sensitivity to the improvement in anticipated costs as a function of redundancy due largely to the significantly greater number of missions planned as compared to those for the Mk I system. The full advantage of the large reduction in potential aborts is inhibited by the greater sensitivity to the increased weight penalties, \$16.5 K/lb vs. \$9.0 K/lb for the Mk I. Therefore, this sensitivity to the weight penalty makes the FO²/FS even less attractive when compared to the selective redundancy approach.

REDUNDANCY SELECTION TRADEOFF, Mk II, HO/R-S-1C

	R_{CS}	R_{MS}	No. of Aborts	$\Delta Wt/$ Veh, Lb	ΔEq Cost/ Veh, \$M	Cost Savings, \$M
Min Config (FS)	.99427	.71939	97.1	—	—	—
Cost Model	.99997	.99824	0.6	1415	1.60	387
Payload Model	.99997	.99824	0.6	1415	1.60	387
FO/FS	.99977	.99054	3.3	1305	1.39	378
FO ² /FS	.99999	.99954	0.2	2611	2.78	364

$$\Delta \text{Savings (From FS)} = (\Delta \text{ No. of Aborts}) (\text{Mission Cost}) - (\Delta W) \left(\frac{\text{Cost}}{\text{Lb}} \right) - (\Delta \text{ Eq Cost}) (\text{No. of Vehicles})$$

R_{MS} = Probability of Mission Success

R_{CS} = Probability of Crew Survival

The application of the selective redundancy approach for the Mk I, HO/BRB shuttle-system confirms the conclusions reached from the previous tables relating to the shuttle configurations employing the R-S-1C booster. However, the sensitivity to mission costs (cost of an abort) which are higher for the BRB, increase the cost savings substantially when redundancy is applied. These savings range from \$326M to \$353M with the costs associated with the large weight penalty of the FO²/FS causing the spread of \$27M.

REDUNDANCY SELECTION TRADEOFF, MK I, HO/BRB

	R_{CS}	R_{MS}	No. of Aborts	$\Delta Wt/Veh$	$\Delta Eq Cost/Veh, \$M$	Cost Savings, \$M
Min Config (FS)	.99427	.71939	27.8	—	—	—
Cost Model	.99997	.99824	0.2	1415	1.60	353
Payload Model	.99984	.98234	1.7	720	1.23	347
FO/FS	.99977	.99054	0.9	1305	1.39	346
FO²/FS	.99999	.99954	0.1	2611	2.78	326

$$\Delta Savings \text{ (From FS)} = (\Delta \text{ No. of Aborts}) (\text{Mission Cost}) - (\Delta W) \left(\frac{\text{Cost}}{\text{Lb}} \right) - (\Delta \text{ Eq Cost}) (\text{No. of Vehicles})$$

R_{MS} = Probability of Mission Success

R_{CS} = Probability of Crew Survival



Savings associated with the additional redundancy become even more significant when examining the Mk II, HO/BRB shuttle configuration. The basic savings in program costs are over \$1B.

REDUNDANCY SELECTION TRADEOFF, MK II, HO/BRB

	R _{CS}	R _{MS}	No. of Aborts	ΔWt/ Veh, Lbs	ΔEq Cost/ Veh, \$M	ΔCost Savings, \$M
Min Config (FS)	.99427	.71939	97.1	—	—	—
Cost Model	.99998	.99840	0.6	1428	1.65	1108
Payload Model	.99997	.99824	0.6	1415	1.60	1107
FO/FS	.99977	.99054	3.3	1305	1.39	1079
FO ² /FS	.99999	.99954	0.2	2611	2.78	1070

$$\Delta \text{ Savings (From FS)} = (\Delta \text{ No. of Aborts}) (\text{Mission Cost}) - (\Delta W) \left(\frac{\text{Cost}}{\text{Lb}} \right) - (\Delta \text{ Eq Cost}) (\text{No. of Vehicles})$$

R_{MS} = Probability of Mission Success

R_{CS} = Probability of Crew Survival



The equipments which perform the guidance, navigation and flight control functions are considered necessary for either crew safety (CS) or mission success (MS).

In general, equipments which have been identified as necessary for crew safety require a minimum configuration of two in order to be fail safe (FS). Mission success equipments require a minimum configuration of one. The quantity identified as "required additional redundancy", based upon the operational redundancy model (ORM), when added to the minimum configuration, results in general in the GAC recommended configuration.

The following was used for operational redundancy selection:

- Each of the flight control equipments is necessary for crew safety during de-orbit and landing
- The fly-by-wire flight control system (FBW FCS) and the direct electrical manual backup FCS were each considered necessary for mission success. An alternate assumption, to consider a crew safety FBW FCS without a backup FCS, was discarded. This accounts for the apparent discrepancy indicated in the table by note D.

- Where additional redundancy was indicated as necessary for equipments which exist in each crew station, the redundancy was added to each in order to maintain identical stations
- Future analysis will reconsider the recommendation to use three IMU's rather than four as indicated. Either a decrease in duty cycle or an increase in reliability results in a model recommendation of one rather than two additional IMU's.
- Either the lower or the upper rudder surfaces and a right and left elevon surface were considered sufficient for crew safety
- The actuator configurations considered and recommended require some clarification. Each actuator was assumed to be an independent non-redundant channel. Based upon the adjusted weight, cost and MTBF provided for the ORM, the computer analysis indicated the need for proper operation of two of four prime elevon actuators for MS and one of four for CS, and two of four rudder and one of two speedbrake secondary actuator for MS and one of four for CS

As functional and backup operational modes are identified, and as the design and configuration develop, and as the mission rules are established, these assumptions, along with the reliability models and recommended levels of redundancy, will be updated and refined.

FLIGHT CONTROLS G&N SUBSYSTEM, EQUIPMENT OPERATIONAL REDUNDANCY

Equipment Name	Minimum Config (FS) (A)	Req'd CS	Req'd MS	Additional Redundancy						GAC Recomm. Config
				Cost Model				Payload Model		
				Mk I		Mk II		Mk I	Mk II	
				R-S-1C	BRB	R-S-1C	BRB	R-S-1C/BRB	R-S-1C/BRB	
IMU	2	1	2	2	2	2	2	2	2	3 (B)
Pri Computer	1	0	1	2	2	2	2	1	2	3
ME Cont & ME TVC Elec	2	1	2	1	1	1	1	1	1	3
Contr: OMES, Spbrk, Rudd, Aero	2	1	2	1	1	1	1	1	1	4 (C)
Reentry AD, AD Computer, AD Sensors, Sec Act Elev	2	1	2	1	1	1	1	1	1	3
TTCA & Rotat SS	2	1	2	1	1	1	1	1	1	4 (C)
G&N Sensors	1	0	0	0	0	0	0	0	0	1
Rate Gyro & Accel	1	0	1	1	1	1	1	1	1	2
FBW FCS	1	1	1	1	1	1	1	1	1	2 (D)
Dir Man BU FCS	1	1	0	1	1	1	1	1	1	2
Sec Act Rud & Spbrk	1 (E)	1	1	1	1	1	1	1	1	2
Prim Act Rud & Spbrk	2	1	2	1	1	1	1	1	1	3
Aerospace Cont Elect	1	0	1	1	1	1	1	1	1	2
Prim Actuator Elev	1 (E)	1	1	1	1	1	1	1	1	2
ACPS Cont Elect	2	1	2	1	1	1	1	1	1	3

- Notes:
- A. Minimum Configuration Quantities Are for Each Equipment
 - B. Tentative Value; Further Analyses Are Planned Concerning the No. of IMU
 - C. Denotes Total Quantity for Both Crew Positions
 - D. Refer to Text. Three Units Will Be Utilized
 - E. Refer to Text.



The concepts and assumptions which were the basis for this analysis were two-fold. First, it was assumed that all of the data processed by each RAU and DAC was essential for mission success, i.e., a loss of any piece of data/information would require termination of the mission. This assumption is most conservative, for undoubtedly, a portion, yet to be determined, of the data processed by each RAU/DAC will not be required for mission success. It was also assumed that loss of all data would not affect crew safety, i.e., the crew would be able to effect a safe abort without the Data Acquisition Subsystem.

Secondly, an RAU/DAC was considered as a

single channel, non-redundant entity. The weight, cost, MTBF, etc. provided for the operational redundancy model were adjusted accordingly. The results of the computer analysis indicates that each RAU no. 1 through no. 6 and the DAC should be made redundant as a cost effective measure.

The Mass Memory operational redundancy calculation indicates that the addition of two units is the most cost effective approach, for a total of three mass memories. Future analyses are planned concerning this finding.

DATA MANAGEMENT SUBSYSTEM, EQUIPMENT OPERATIONAL REDUNDANCY

Equipment Name	Minimum Config	Req'd CS (FS)	Req'd MS	Additional Redundancy						GAC Recomm Config
				Cost Model				Payload Model		
				Mk I		Mk II		Mk I	Mk II	
				R-S-1C	BRB	R-S-1C	BRB	R-S-1C/BRB	R-S-1C/BRB	
Mass Memory	1	0	1	2	2	2	2	1	2	3 (c)
Data Acq Contr*	1	0	1	1	1	1	1	1	1	2
Remote Acq										
Unit 1*	1	0	1	1	1	1	1	1	1	2
Unit 2*	1	0	1	1	1	1	1	1	1	2
Unit 3*	1	0	1	1	1	1	1	1	1	2
Unit 4*	1	0	1	1	1	1	1	1	1	2
Unit 5*	1	0	1	1	1	1	1	1	1	2
Unit 6*	1	0	1	1	1	1	1	1	1	2
Computer	P/D G&N									

- Notes:
- A. A Portion of the Data Processed by Each RAU/DAC Is Not Required for Mission Success. The Model Assumes All Data Is Required
 - B. The Minimum Configuration Consists of Single Channels.
 - C. Tentative Value, Future Analyses Are Planned Concerning The No. of Mass Memory Units

* Denotes a Single Channel



Functions

The crew safety functions of the Telecommunications Subsystem (TCS) are voice link, for all mission phases, and landing aid for the landing phase. The remaining functions of the TCS are mission success related rather than crew safety, except for the VHF beacon and the flight recorder, whose functions are not necessary unless the vehicle has crashed.

Minimum Configuration

Orbiter voice links with the ground are established with either dual redundant S-band or UHF equipment, together with an internally redundant signal processor and audio center. During ascent and orbital mission phases, primary communications with the ground MSFN is achieved at S-band. UHF provides a functional backup during these mission phases and is prime during atmospheric flight. Furthermore, UHF is compatible with most MSFN, ATC and world wide ground stations, thus enhancing voice communications coverage. Adequate fail safe voice communications is provided via UHF and S-band.

The most important function of the Command Decoder is to provide to the computer, via the S-band link, information to update the inertial navigation system prior to re-entry. Since the same data can be transmitted by voice link and inserted into the computer by the crew by means of the keyboard, the Command Decoder is not a crew safety item.

The TACAN Transceiver provides rendezvous capability in the orbital phase, and conventional TACAN navigation functions (range and bearing to a known site) in the post re-entry phase. The rendezvous function does not impact crew safety, and the post re-entry navigation can be accomplished, although in a degraded manner, by using the voice link to provide navigation cues.

The Ku-band Microwave Scanning Beam (MSB) Transceiver/Decoder provides the alignment and glide slope landing aid information to the crew for the landing phase. This function affects crew safety, and the fail-safe requirement is met by providing duplicate equipment. The C-Band Altimeter provides height-above-terrain data to the crew and is used as a confidence check on the MSB. In the event of an abort to an alternate landing site which does not provide MSB compatibility, the altimeter becomes an essential instrument in landing safely. The altimeter is not included in fail-safe considerations since it comes into play only after the first failure has occurred. The antenna systems are considered to be fail safe, since failure results in degraded but acceptable antenna pattern coverage.

Recommended Configuration

The recommended configuration has been derived from the minimum configuration by adding redundancy where economically justifiable.

TELECOMMUNICATIONS SUBSYSTEM, EQUIPMENT OPERATIONAL REDUNDANCY

Equipment Name	Minimum Config.	Req'd CS (FS) (B)	Req'd MS	Additional Redundancy						GAC Recomm Config
				Cost Model				Payload Model		
				Mk I		Mk II		Mk I	Mk II	
				R-S-1C	BRB	R-S-1C	BRB	R-S-1C/BRB	R-S-1C/BRB	
S-Band Ant Sys	1 (A)	1	1	0	0	0	0	0	0	1
S-Band Sw/Tplx	1 (A)	1	1	0	0	0	0	0	0	1
S-Band Xcvr	1	1	1	1	1	2	1	1	1	2
UHF Ant Sys	1 (A)	1	1	0	0	0	0	0	0	1
UHF Ant Sw	1 (A)	1	1	0	0	0	0	0	0	1
UHF Xcvr	1	1	1	1	1	1	1	1	1	2
TACAN Ant Sys	1 (A)	0	1	0	0	0	0	0	0	1
TACAN Ant Sw	1 (A)	0	1	0	0	0	0	0	0	1
TACAN Xcvr	1	0	1	1	1	1	1	1	1	2
C-Band Ant Sys	1 (A)	0	0	0	0	0	0	0	0	1
C-Band Alt	1	0	0	0	0	0	0	0	0	1
Ku-Band Ant Sys	1 (A)	1	1	0	0	0	0	0	0	1
Ku-Band Xcvr	2	2	2	0	0	0	0	0	0	2
Sig Processor	2	2	2	1	1	1	1	1	1	3
Audio Center	2	2	2	1	1	1	1	1	1	3
Cmd Decoder	1	0	1	1	1	1	1	1	1	2
Beacon & Recorder	1 ea	0	0	0	0	0	0	0	0	1 ea

- Notes: A. Indicates Fail Safe Characteristics Inherent in Design
 B. Voice Link and Landing Aids Are the Only Crew Safety Functions



The EPS is composed of two electrically isolated, independent fail safe sections (left and right sides) with each section servicing one half the vehicle. Each section is designed to be fail safe as a minimum. Crew safety primary equipments are powered from one EPS section and the backups from the other section.

The application of cost-effectiveness criteria to the minimum configuration resulted in no additional redundancy required. Because of the degree of functional redundancy, a substantial portion of the EPS components can fail before an abort becomes necessary. The components required to permit a safe abort are:

- Either one of two fuel cells and one of two inverters or one of four APU/generators and one of two forward TR's

- And one of two aft T/R's (because of the isolation scheme, only a T/R can be powered by any given APU/Generator).

Loss of both fuel cells prior to completion of the orbital phase necessarily results in a mission abort. Since the APU hydrazine fuel supply is sized for the aerodynamic flight phases, totaling a few hours, sufficient fuel for generating electrical power for sustained orbital operations is not available.

The major role of the emergency batteries is to sustain vehicle loads during system re-configuration, in the event of failure of a prime power source.

ELECTRICAL POWER SUBSYSTEM, EQUIPMENT OPERATIONAL REDUNDANCY

Equipment Name	Minimum Config	Req'd CS (FS)	Req'd MS	Additional Redundancy						GAC Recomm Config
				Cost Model				Payload Model		
				Mk I		Mk II		Mk I	Mk II	
				R-S-1C	BRB	R-S-1C	BRB	R-S-1C/BRB	R-S-1C/BRB	
APU/Gen	4	4	4	0	0	0	0	0	0	4
Fuel Cell	2	2	2	0	0	0	0	0	0	2
Inverter	2	2	2	0	0	0	0	0	0	2
Battery	(A)									2
Battery Chgr.	(B)									2
Xfmr/Rect/Fwd	2	2	2	0	0	0	0	0	0	2
Xfmr/Rect/Aft	4	4	4	0	0	0	0	0	0	4
Regulator	2	0	2	0	0	0	0	0	0	2

- Notes: A. Battery Required Only for Emergency Situations
 B. Battery Charger Operates Only to Maintain Battery Full Charge Condition



The Instrumentation Subsystem consists of sensors and associated signal conditioning electronics necessary to provide vehicle measurements information to the crew and/or ground. It also includes a Flight Recorder with its associated electronics, and two Data Log Recorders.

A general conceptual analysis has been performed. It has been assumed for this study that most sensors will have no significant adverse effect on crew safety (CS) or mission success (MS). In future studies a number of measurements will be identified as necessary for mission success and a portion of these MS measurements will also be required for crew safety. The recorders and associated electronics and non-critical sensors and conditioners have been omitted from the CS and MS reliability models. No instrumentation equipment has been included in the reliability opera-

tional redundancy model.

It is intended, by design and/or configuration, to eliminate any adverse effect on CS and MS for all critical measurements. Future studies will determine recommendations for operational redundancy. A reliability model will be completed for MS and CS for each mission Phase I-III boost, orbital operations, and deorbit/landing, respectively.

Finally, it should be noted that there is no mission success model for Phase III, since it is assumed that during the down phase, the optimum mission termination path would already be employed. Therefore, all equipment would be configured for the safe return of the crew and only a crew safety model is valid for Phase III.

INSTRUMENTATION SUBSYSTEM, EQUIPMENT OPERATIONAL REDUNDANCY

Equipment Name	Minimum Config	Req'd CS (FS)	Req'd MS	Additional Redundancy						GAC Recomm Config
				Cost Model				Payload Model		
				Mk I		Mk II		Mk I	Mk II	
				R-S-1C	BRB	R-S-1C	BRB	R-C-1C/BRB	R-S-1C/BRB	
Flt Recorder	1	0	0							1
Data Log Recorder	2	0	0							2
Signal Condtnrs				TBD						TBD
Critical	2 ea	TBD	TBD							
Non Critical	1 ea	0	0							1
Sensors:				TBD						TBD
Critical	2 ea	TBD	TBD							
Non Critical	1 ea	0	0							
Electronics										
Flt Recorder	1	0	0							1

Note: The Identity and Number of Critical CS/MS Signal Conditioners and Sensors Will be Determined as the Design Develops. Additional Redundancy and GAC Recommendations Will Be Determined in Subsequent Studies.

Program penalty costs for both program phases, Mk I and Mk II, and for each booster, R-S-1C and BRB, were calculated as a function of redundancy levels. Costs were computed for each redundancy level (FS, FO/FS, FO²/FS) in addition to the selective redundancy determined by the Cost/Payload models. Reference to the histograms shows that the FS (minimum) configuration results in program penalty costs of the order of 10 to 20 times those of the Cost/Payload configurations. The FO/FS and FO/FO/FS configurations incur penalty costs ranging from 20% to 60% greater than those for the Cost/Payload configurations.

The recommended configuration was developed from the FS (minimum) configuration as follows:

Redundancy allocations were evaluated independently for the Mk I and Mk II programs, since the operational/vehicle parameters vary for each program.

Each program was evaluated using both the Cost and Payload models to determine the economically optimum level of redundancy. The results of each evaluation were virtually identical, i.e., where differences existed, engineering judgement was applied to determine the final configuration.

The differences in cost among the various configurations result from the interplay of three cost factors:

- Abort Costs: Expected number of aborts X cost per mission
- Δ Equipment Costs: The cost of the additional equipment due to the redundancy added above the FS configuration
- Δ Weight Costs: The weight of the additional equipment X Penalty cost per pound

COSTS VS REDUNDANCY LEVELS R-S-1C

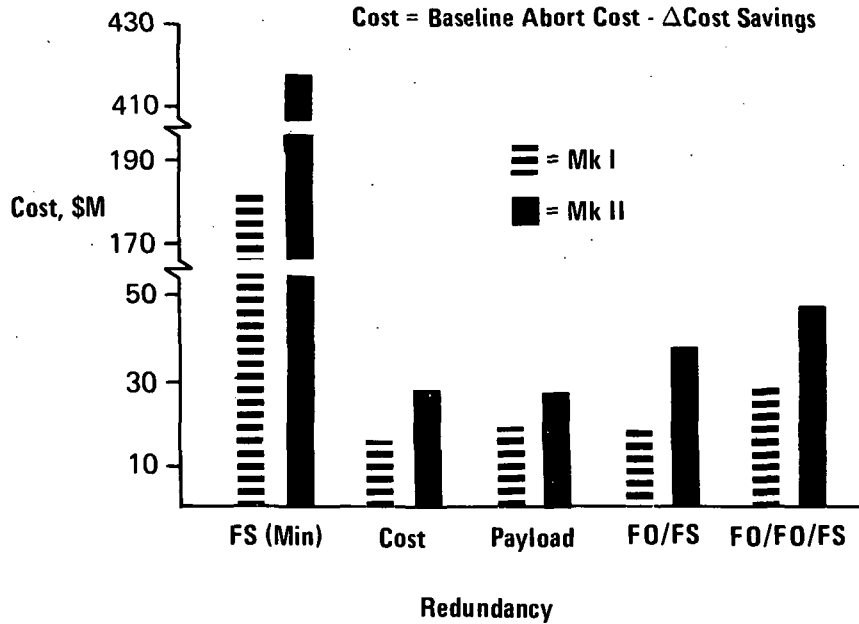

The FS configuration has the minimum redundancy, and consequently, the lowest reliability and the highest number of aborts. Since this is the minimum configuration, there are no associated equipment and weight penalties; the total FS penalty cost is solely due to abort costs.

The FO/FO/FS configuration has the maximum redundancy, and consequently, the lowest abort costs. The high redundancy level incurs the maximum equipment and weight penalty costs.

The FO/FS configuration has a lower penalty cost than FO/FO/FS since the higher associated abort costs are more than offset by the reduction in the equipment and weight penalties.

The Cost and Payload configurations yield penalty costs which are essentially equal, and as would be expected, the lowest of all the configurations evaluated. In these configurations, redundancy is allocated in accordance with economic criteria rather than arbitrary rules, as is the case with the other configurations. The differences between the Cost and Payload configurations stem from the criteria used for adding redundancy. The Payload model optimizes the probability of payload delivery to orbit and reduces the effective payload by the weight of redundancy added; the Cost model minimizes the total program costs and maintains a fixed payload and allows the vehicle to grow as redundancy is added.

COSTS VS REDUNDANCY LEVELS, BRB

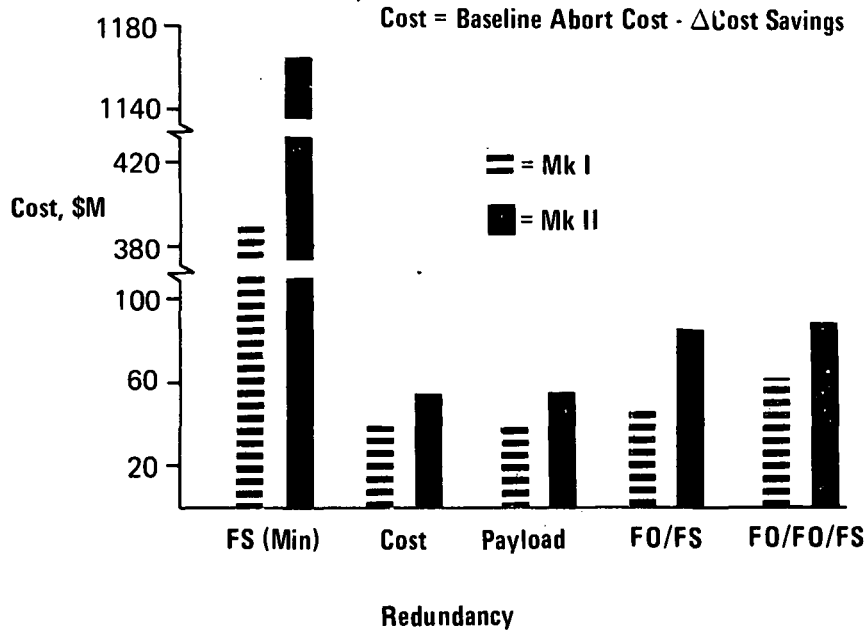

MAJOR DECISIONS

- Aerodynamic Flight Control Computer – Dedicated vs Integrated
- Aerodynamic Flight Control Computer – Digital vs Analog
- Flight Control Back-Up – Fly-by-Wire vs Mechanical
- Guidance & Navigation Computer – Integrated vs Dedicated
- Crew Size – Two vs Three
- Data Bus – Acquisition Only vs Acquisition & Command
- Power Distribution, Condition & Control – Conventional vs Solid State
- Displays & Controls – Dedicated vs Integrated

The horizontal flight test aerodynamics FCS configuration is effectively decoupled from space flight controls. This approach reduces development risk for FHF and offers the potential for deferment of space equipment costs if desired.

Orbiter and R-S-IC, booster are similar with approximately 57% commonality. Both use a common digital primary flight control incremental computer. The booster has a dissimilar backup in the form of a hard Stability Augmentation System. The orbiter uses a direct electrical analog backup based on the inherent stable airframe characteristics of the Phase B orbiter. (Augmentation may be necessary

for HO Orbiters if wind tunnel tests indicate stability enhancement is necessary.)

An interim attitude and heading reference system is included for the horizontal test program to preclude need for inertial platforms in the early phases of the test program. Rate gyros, linear accelerometers and air data sensors provide basic information required for augmentation and autopilot mechanization. The microwave scanning beam system is added late in the test program for IFR landings. If unmanned vertical flight test is required, the aerodynamic portion of the flight is tested and evaluated during the horizontal test program.

FLIGHT CONTROLS

FHF

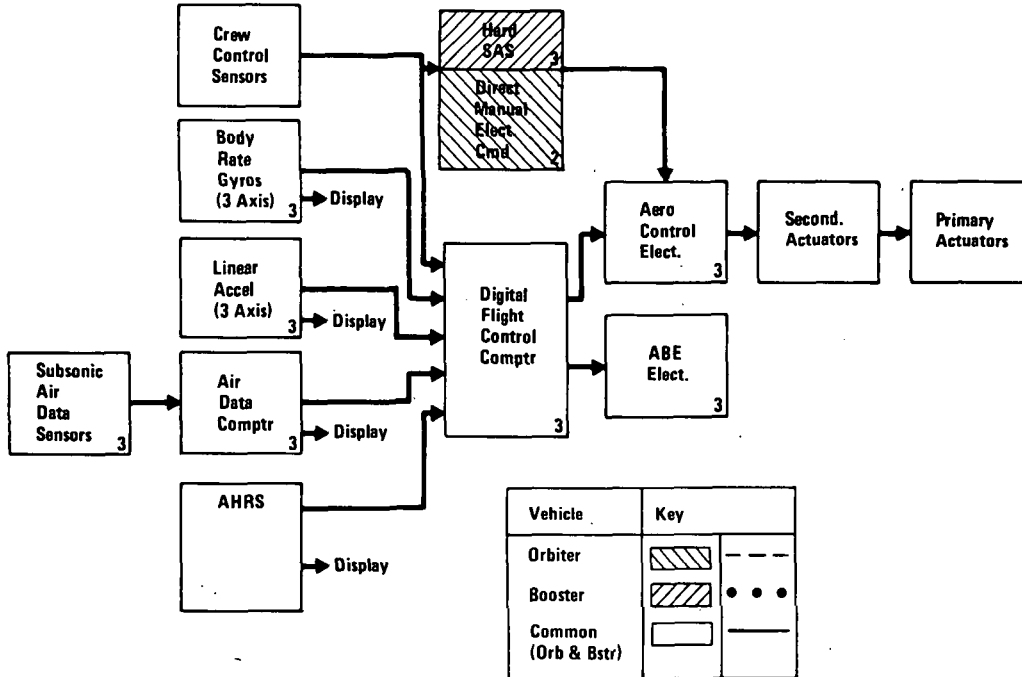

For Mk I and II, the basic aerodynamic control system for the horizontal test program is supplemented with the addition of space flight hardware and software. These include: the IMU's and Primary digital computer; the control electronics for ACPS control; main engines, and in the case of the orbiter, the OMES control electronics. At this point the interim attitude and heading reference used for horizontal testing is removed.

If unmanned vertical flight test is required, additional equipment is necessary. Space and aero flight couplers are added to perform functions nor-

mally accomplished by the crew. Either direct commands via up link or sequential commands from the onboard computer are possible. The aerodynamic flight portion will have been tested and proven during horizontal testing. Either ground and/or airborne (chase plane) control would be provided for approach and landing.

Auto land capability will be incorporated in Mk II with IFR for Mk I and late horizontal flight test. The need for hypersonic air data for entry and transition is currently under evaluation.

FLIGHT CONTROLS

~~FOR~~ MARK I & MARK II

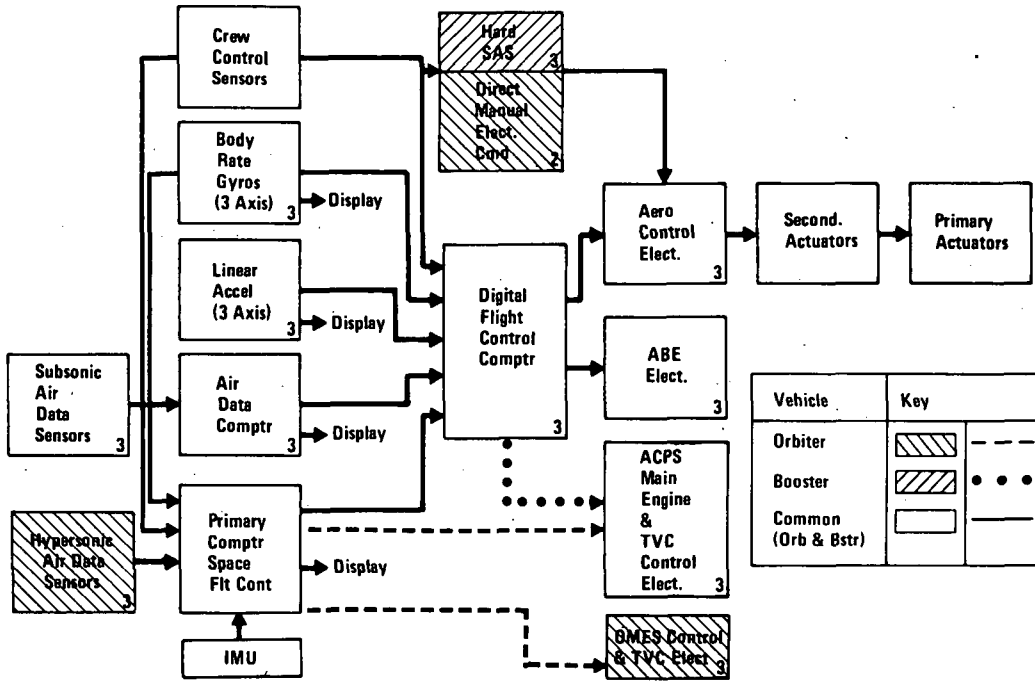

Vehicle	Key	
Orbiter		- - - -
Booster		• • • •
Common (Orb & Bstr)		—



A digital primary flight control computer backed up by a dissimilar redundant analog system is recommended. The digital approach offers many advantages over analog, e.g., accommodates change easily via software, has a wider dynamic range, is lighter, cheaper, more precise, and can use existing equipment and software specifically designed for control applications. The prime disadvantage of the digital approach is the question of software development risk. This could be a problem using a general purpose machine and developing software from

scratch.

The Grumman/Boeing recommendation is to use an existing Variable Digital Incremental Computer. This machine is specifically designed for control system applications and has been flight tested on 707 and 727 autoland systems. Programming is simple and is analogous to programming an analog computer. Supporting software in the form of assembly and simulation programs exist. This combination of advantages offers a significant reduction in software development risk.

SYSTEM ARCHITECTURE, MAJOR DECISIONS

DIGITAL AERO FLIGHT CONTROL COMPUTER

ADVANTAGES OVER ANALOG

- A. Easier to Accommodate Changes
(Boeing SST Experience With Analog A Major Risk Factor)
- B. Can Easily Accommodate Wide Range of Performance Requirements. (Analog Autopilot May Push State-Of-Art)
- C. Better Control of Tolerances, Errors and Limits; Especially Important In Auto-Reconfigurable Systems (Fewer Nuisance Interrupts)
- D. Simpler Interface With G&N Digital Computer
- E. Common Equipment on Orbiter and Booster (Analog Would Require 2 Different Developments) Reduces GSE, Spares, etc.

DISADVANTAGES COMPARED TO ANALOG

- A. Most Aero Flight Control Experience is With Analog Implementation
- B. Software Development Problems
- C. Although Experience With Digital Equipment is Minimal Several Programs Will Have Gained Experience:
 - F-14 Digital Wing Sweep Program
 - NASA F-8 With Apollo Computer
 - Boeing DASH 80 Auto Land
 - Boeing 727 Auto Land

SYSTEM ARCHITECTURE, MAJOR DECISIONS

DEDICATED AERODYNAMIC FLIGHT CONTROL COMPUTER FOR ORBITER AND BOOSTER

ADVANTAGES

- A. De-Couple Risk (Central Computer Not Required for HFT Program)
- B. Forces Software Modularization
- C. Provides Greater Software Visibility
- D. Simplifies Test Programs
- E. Uses Existing Hardware

DISADVANTAGES

- A. May Add Weight to Final System
- B. Less Flexibility
- C. More Software Packages

SYSTEM ARCHITECTURE, MAJOR DECISIONS

FLY BY WIRE

ADVANTAGES

- A. Saves Weight
 - Orbiter 342 Lb
 - Booster 760 Lb
- B. Booster - Is Unstable and Cannot be Flown by Cable System Without an Electronic Stability Augmentation System
- C. Control Column Not Required. (Benefit to Orbiter Cockpit)
- D. Less Concern About Vacuum Welding: Bearing Lubrication; Press. Vessel Penetration, ETC.
- E. Secondary Weight Savings Can Be Substantial for Control Configured Vehicle, i.e., Reduced Tail and Control Surface Areas, Loads, Power

DISADVANTAGES

- A. Has Never Been Completely Done for A/C. (All Spacecraft Are Fly by Wire and Some A/C Partially, i.e., F-111, F-14 Spoilers)
- B. Susceptible to Total Electrical System Failure. (Total Electrical Failure Could be Catastrophic For Many Other Reasons - Depending on Where the Failure Occurs in the Mission. Loss of APU Results in Loss of Hydraulic Power)

Past experience has shown that this particular trade study generates considerable "emotional" as well as technical discussion. The Grumman/Boeing studies have attempted to filter out the emotional/subjective considerations and have concentrated on technical/objective factors.

Inclusion of a mechanical cable system in an FCS design implies basic airframe stability. That is, for an unstable airframe, a manual mechanical cable system without electrical stability augmentation would be of no value. Candidate mechanical longitudinal and directional flight control system designs for the booster are schematically represented in the accompanying illustrations. All major mechanical components (cable, control stick, trim actuators, etc.) are identified. The total weight for a mechanical system of this type for the orbiter is 481 lb. Inherent to the design of any mechanical cable system are the following problems:

- Cockpit pressure seals
- Mechanical jamming
- Friction
- Hysteresis.

When considering large and long vehicles, such as the orbiter and booster, these mechanical system problems are aggravated even more.

In recent years, a distinct trend away from mechanical systems and toward fly-by-wire (FBW) control systems has been observed. High performance military aircraft, such as the F-111 and F-14 have fly-by-wire control for their spoiler surfaces. In addition, the Air Force F-4 680J program and NASA FRC F-8 program are two experimental fly-by-wire test programs that are currently underway.

Taking into consideration specific orbiter and booster control system performance and flying qualities requirements, a triply redundant digital primary fly-by-wire control system has been baselined for both vehicles. Concern over common mode failures led to the inclusion of a dissimilar backup FCS. Since the orbiter is inherently stable, two design options were available for the backup FCS: 1) mechanical cable system or, 2) direct manual analog electrical command, i.e. electrical analog of mechanical cable system.

FLY-BY-WIRE (PITCH AXIS ONLY SHOWN)

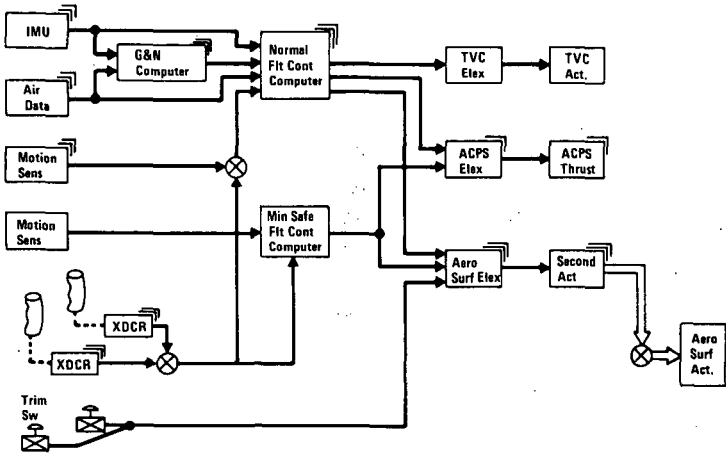

The backup FBW system positions the aerodynamic control surfaces proportional to cockpit controller displacements. Implementation of the dual system is via dedicated hardware and direct wire cable runs up to the actuation subsystem. The backup system is integrated into the prime system to provide minimum engage/disengage transients with maximum isolation. A separate dedicated power system supplies ac and dc power to the dedicated components. Integral failure detection and isolation, along with pilot warning, is provided to indicate backup system status.

This dual redundant manual direct FCS weights 139 lb and requires 298 w of power. When compared to the mechanical system on a cost and weight basis, the choice of the direct electrical analog command configuration as the orbiter backup FCS is clearly justifiable. The major objection raised with respect to employing a backup FBW system has been concern over complete loss of electrical power. This concern is felt to be unwarranted based on data obtained from Eastern Airlines and Boeing experience with loss of electrical power in its commercial fleet to 1969. One failure per 1,600,000 flight hours with almost negligible effects clearly indicate that loss of electrical power through lightning strikes or any other phenomenon

should not be used as an argument against baselining a complete FBW FCS. Eastern Airlines data augments the Boeing data by indicating that their experience reports only ten lightning strikes per million flight hours with no reported power losses. An additional fallout advantage of going FBW for both the primary and backup FCS is that only one type of pilot rotational controller (side stick) is required. If a backup mechanical system had been incorporated instead, a cockpit control stick would also have to be provided.

The basic booster airframe is unstable and as a result requires a stability augmentation fly-by-wire backup FCS.

The concept of using FBW/stability augmentation control techniques provides some very interesting vehicle structural/aerodynamic design options. For example, an airframe such as the orbiter, could be purposely designed to be unstable (e.g., reduced wing area) in order to save vehicle weight (possibly thousands of pounds). Reliance would then fall upon the FBW/stability augmentation system to improve the basic airframe performance/stability. This approach to airframe design is referred to as "control configured vehicle."

FLY-BY-WIRE (PITCH AXIS ONLY SHOWN) WITH AERO MECHANICAL BACK-UP

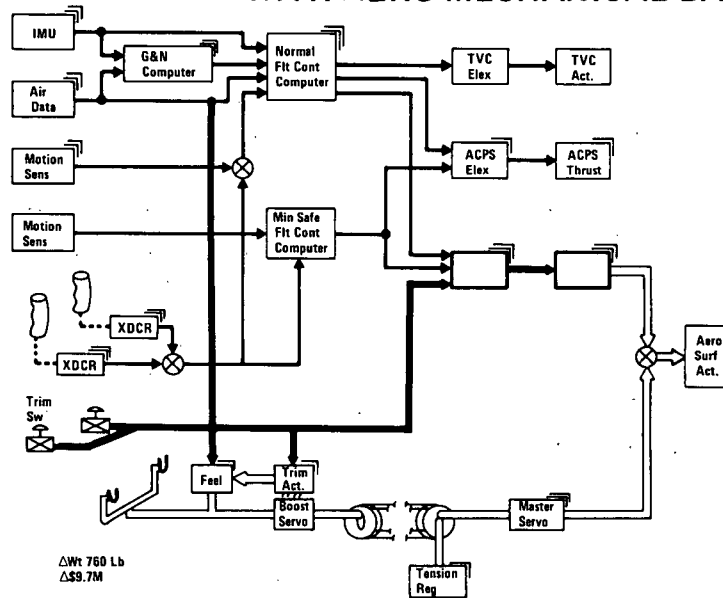

The spacecraft Guidance Navigation and Control and Data Management Systems development will be performed in phases corresponding to the vehicle development. First horizontal flight (FHF) will use the C-band radar for ground controlled area/landing functions and a limited data acquisition system which contains the caution and warning (C&W) function.

Data controllers control the flow of data from the remote acquisition units (RAU), perform

C&W processing, format and control the flow of data to the telemetry and the flight recorder. The RAU's as presently sized will have the capability for handling 96 bi-level and 96 analog signals. They will also include integral standard signal conditioning.

Upon completion of the first phase of the horizontal flight test program both subsystems will be expanded as required to meet flight test objectives.

GN&C AND DMS FHF

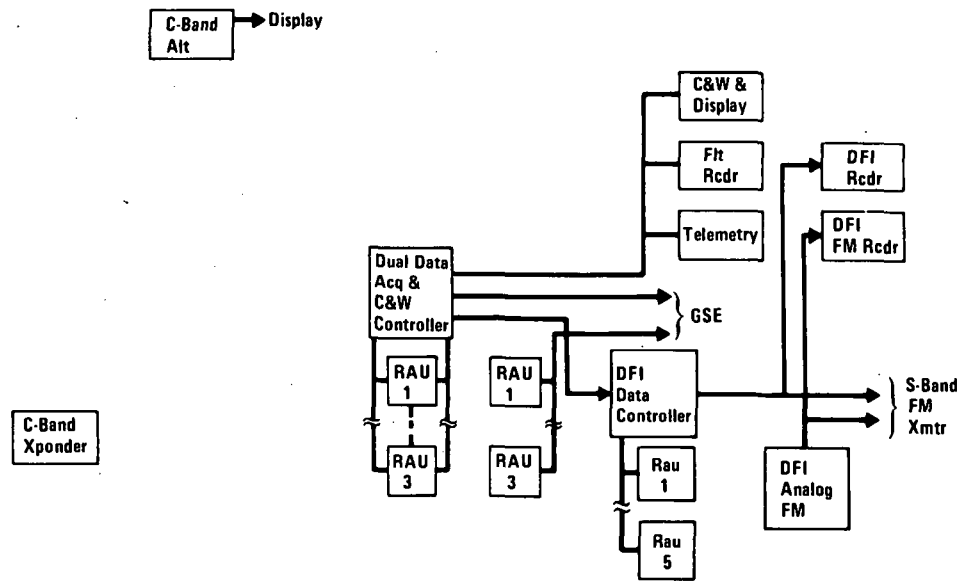

The systems added for Mk I include the three inertial platforms single threaded to three primary (general purpose) computers. The inertial platforms have four gimbals to avoid the imposition of attitude restrictions on the vehicle through all mission phases. The array of navigation aids added to the Mk I avionics provide the potential for fully autonomous guidance and navigation operations; however, ground tracking (i.e., MSFM for spacecraft operations and C-band for area navigation through approach) is incorporated leaving open the option to include autonomy through software modifications later in the program.

Navigation aids which can meet requirements for several mission phases were selected. TACAN is utilized for post-blackout area navigation and rendezvous ranging. The Multi-Mode Optical Sensor (MMOS), a fixed-base device, was selected as a low-cost, highly reliable system to perform

in-orbit IMU alignments and rendezvous with the option to include horizon sensing capability as a viable means for performing orbit navigation. The Crew Optical Alignment Sight (COAS) is added for line-of-sight control functions during terminal rendezvous and as a back-up inertial system alignment device. The Microwave Scanning Beam system is interfaced to the primary computers for conditioning the information required for manual IFR landings.

A data log recorder interfaced to the data controller is added and the data acquisition system is expanded to meet the full vehicle requirements for subsystem reporting and management. Two data entry keyboards (with displays (DEK) are added and the data controller is interfaced with the primary computers to increase the crews ability to perform their system management function.

GN&C AND DMS

PHASE I

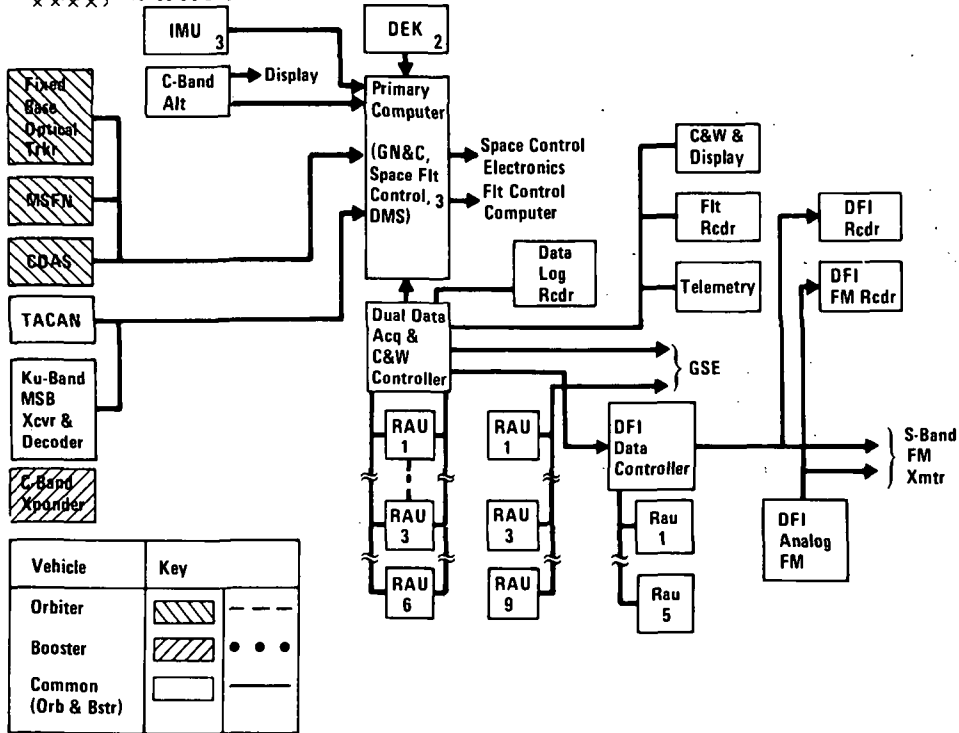

GN&C and DMS Mark II

The Mk II GN&C and DMS are essentially identical to Mk I in terms of architecture.

Those autonomous functions which will replace MSFN during Mk II are orbit navigation using the TDRS plus an option of using the Fixed Base Optical Tracker (MMOS) in a back up mode.

The rendezvous maneuvers will be computed based on MMOS and TACAN data. Terminal area maneuvers (i.e., area navigation and landing) will incorporate the FAA version of MSB (i.e., MSL) and an option for autoland, depending on HFT Mk I flight test results.

RAU's and the ground based Data Acquisition Controller used for ground checkout during Mk I are incorporated into the onboard data acquisition system. This provides essentially onboard checkout capability to an LRU.

The primary computers are expanded to incorporate 48K of memory and interface with two mass memories (tape) and two multi function displays (MFD). Mass memory will be used for storage of G&N, configuration management, mission support, subsystem checkout, and MFD/programs.

SYSTEM ARCHITECTURE, MAJOR DECISIONS

G&N FUNCTION IN CENTRAL COMPUTER VS. DEDICATED NAVIGATION COMPUTER (INS AND COMPUTER PACKAGE)

CENTRALIZED (ADVANTAGES)

- A. Increased Flexibility
- B. Reduced Weight, Power and Volume
- C. Failure Monitoring Can Be Automated
- D. In-Orbit Alignment Interfaces Simplified
- E. Reduces Ground Support Equipment, Spares, etc..

DEDICATED NAV (ADVANTAGES)

- A. Existing INS/Computer Packages Could Save New Software Development
- B. Could Readily Be Available for First Horizontal Flight
- C. Would Reduce Software Management and Verification Costs

COMPUTER MEMORY SIZING

	Phase B		FHF		Mk I		Mk II	
	Orbiter	Booster	Orbiter	Booster	Orbiter	Booster	Orbiter	Booster
DM/G&N	40K	40K	-	-	32K	24K	48K	Same As Mk I
Flt Control	8K	8K	2K (Equiv)	2K (Equiv)	2K (Equiv)	2K (Equiv)	2K (Equiv)	Same As Mk I
Data Acq C&W	In DM/G&N	In DM/G&N	4K	4K	4K	4K	4K	Same As Mk I
Air Data Computations	In DM/G&N	In DM/G&N	2K	2K	2K	2K	2K	Same As Mk I
Mass Memory (Mission & Payload Support)	128K	-	-	-	-	-	128K	-

All Numbers 32-Bit Words



Crew station displays and controls subsystem requirements were established consistent with low-cost implementation economies being considered in both the avionic and nonavionic subsystems. Functional requirements for the displays and controls subsystem were established through extensive review of all on-board operational subsystem requirements. Particular emphasis was placed on the operational criticality of each functional requirement and the associated crew procedures. Human engineering considerations and pilot experience were key factors in establishing panel arrangements and determining crew size. MSFN availability, particularly during launch, was utilized to reduce crew work load. Hardware selections were made based on functional characteristics, cost, risk, and reliability. All avionic and non-avionic D & C requirements are traceable through computerized measurement and command lists and

controlled by subsystem functional set drawings (subsystem functional schematics). Full-scale flat plan arrangement boards and quarter scale mockups were utilized to establish crew station panel arrangements and geometry.

The selected design approach for the Mk I and Mk II crew stations utilizes a two man crew in a side-by-side arrangement. Aircraft and spacecraft functions are integrated in a common crew station to reduce panel area and weight. Primary flight displays and controls are duplicated to optimize crew equipment interfaces and reliability while providing a one man emergency return capability from either flight position. The normal systems monitoring functions are integrated into the side and center flight consoles. Critical subsystem functions are centrally located within the reach of both crewmen.

DISPLAYS & CONTROLS — FHF

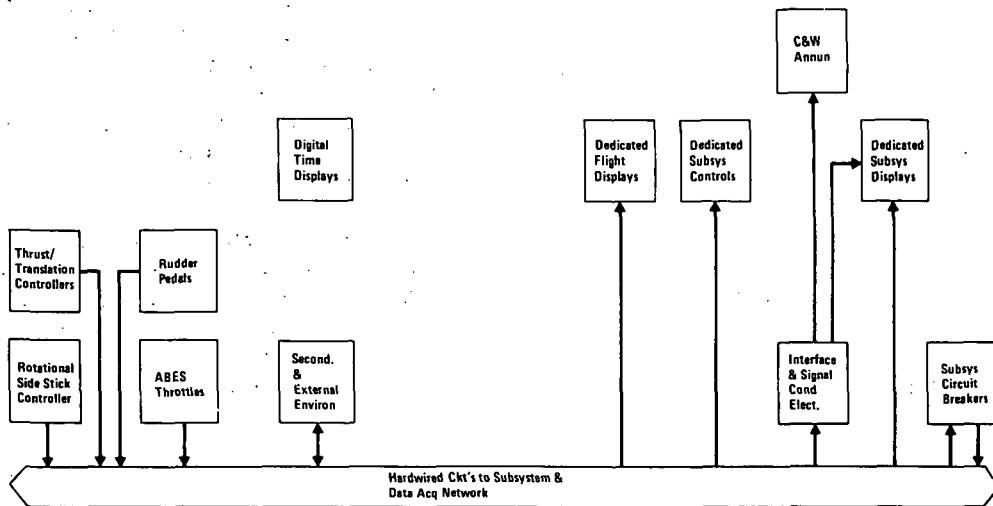

For the FHF test program, only those displays and controls required to monitor and control aerodynamic subsystems are included in the crew station. The Mk I/II crew station design is modular such that a high degree of flexibility is provided to insure maintenance of all components, and the practical separation of aircraft and spacecraft display and control functions while minimizing any constraints on the FHF test program. With the exception of the primary flight displays and controls required for both aerodynamic and space flight, this separation of functions is maintained.

All commands originating in the crew station

are hardwired to the subsystem functions under crew control. Flight data displays are hardwired to data sources. Subsystem and C&W data, with the exception of the data required for vehicle initialization, is collected via a redundant data collection network consisting of RAU's (Remote Acquisition Units) located throughout the vehicle.

Approximately 695 data points are accessible to the crew in the orbiter vehicle via the Mk I dedicated displays. Measurement redundancy is provided for subsystem status data utilizing the two keyboards normally used to input commands to the GN&C computers.

DISPLAYS & CONTROLS – ~~THE~~ MARK I

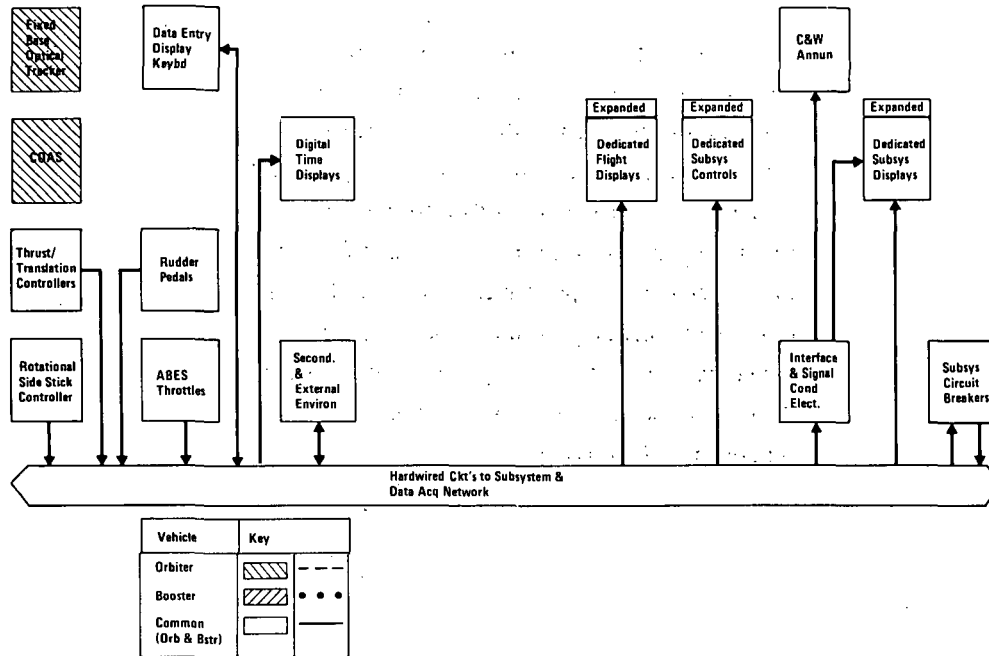

The Mk II vehicle offers a high degree of autonomous on-board crew operation, management and checkout of vehicle subsystems. To enhance the crew's role consistent with operational requirements of the Mk II vehicle, two CRT displays and a micro-film viewer are added to the crew station for display of subsystem and expendables status, and the display of corrective action procedures following a subsystem failure. Data will be presented in sufficient detail to allow the crew to isolate subsystem malfunctions to the LRU level.

DISPLAYS & CONTROLS — ~~THE MARK I~~ MARK II

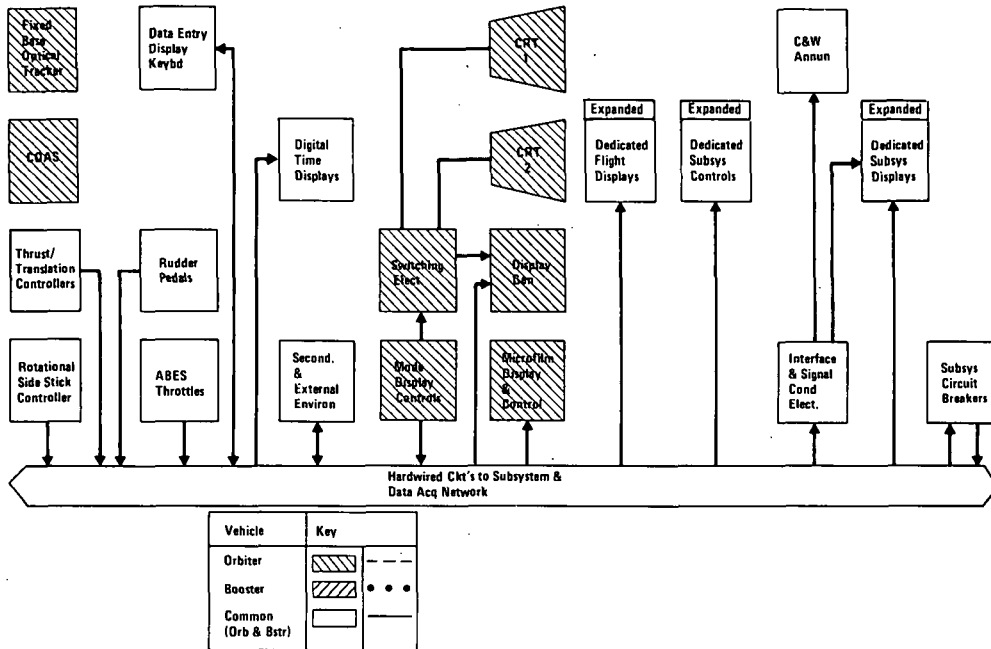

Displays and controls for FHF include:

- Aero flight displays & autopilot controls/SAS
- Primary and secondary aero flight controls
- ABES instruments and controls
- APU's & hydraulic system displays and controls
- Auxiliary systems and controls
- Partial communication subsystem controls
- Partial ECS displays and controls
- C & W displays
- Fire controls for ABES and APU's
- Timers
- Lighting controls
- CB panels

FHF ORBITER DISPLAYS & CONTROLS SUBSYSTEM

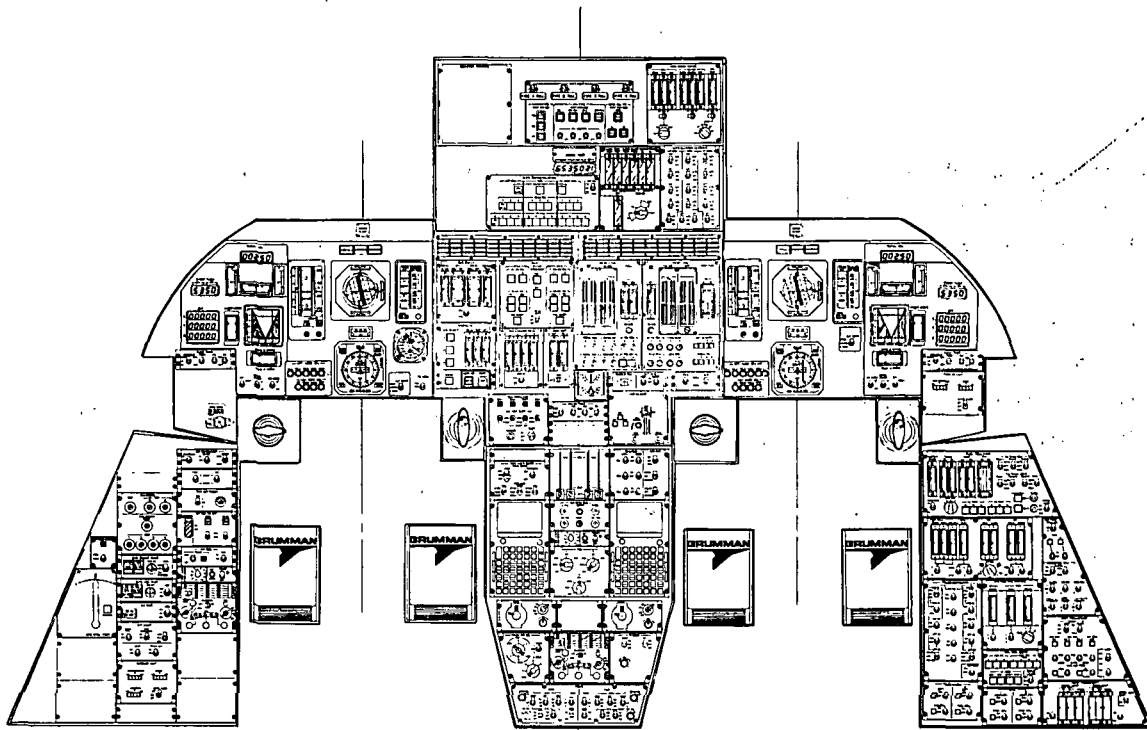

Displays and controls for MK I include the following additions required for space flight:

- Data entry keyboards
- Main propulsion subsystem displays and controls
- ACPS displays and controls
- OMS displays and controls
- Rendezvous and re-entry displays and controls
- Fuel cell and inverter displays and controls
- Spacecraft ECLSS displays and controls
- Space GN&C controls
- System abort displays and controls
- C&W for space functions
- Pyro and system separation controls (external tanks, etc.)
- External doors and compartment status displays
- Payload deployment and retrieval

MK I ORBITER DISPLAYS & CONTROLS SUBSYSTEM

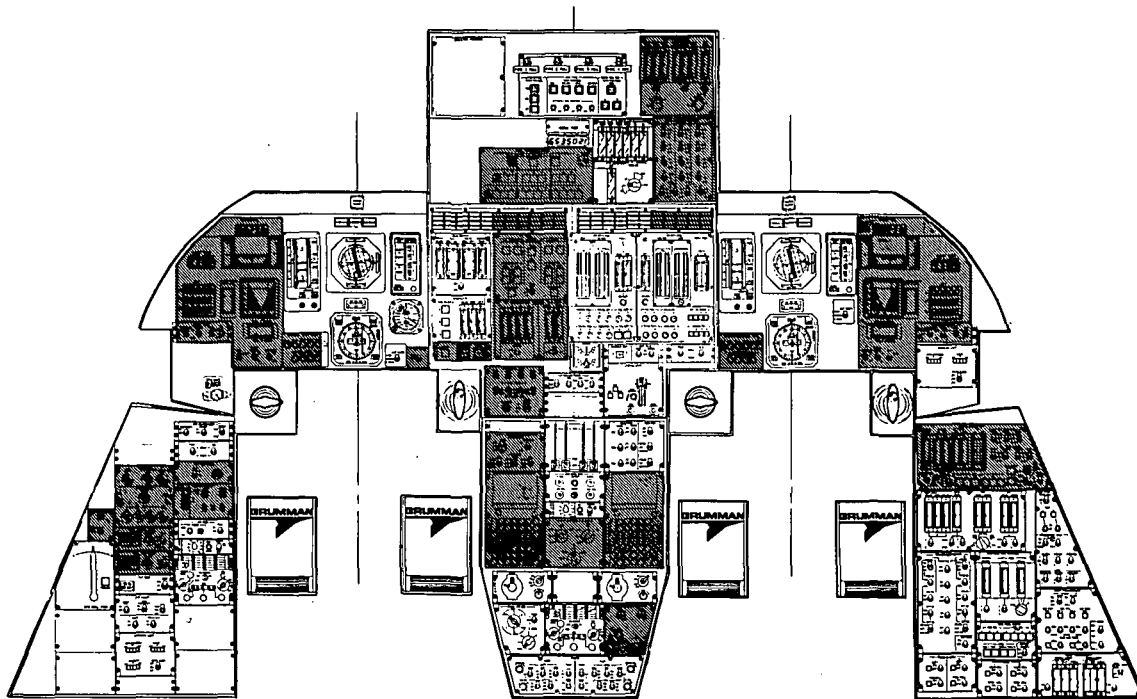

Displays and controls for MK II include the following additions:

- Two CRT MFD's for on-board checkout
- Microfilm display for malfunction procedure and textbook data
- Display and controls for docking
- Controls for TDRS comm link, and extended EVA communications
- Payload monitoring and control

MK II DISPLAYS AND CONTROLS SUBSYSTEM

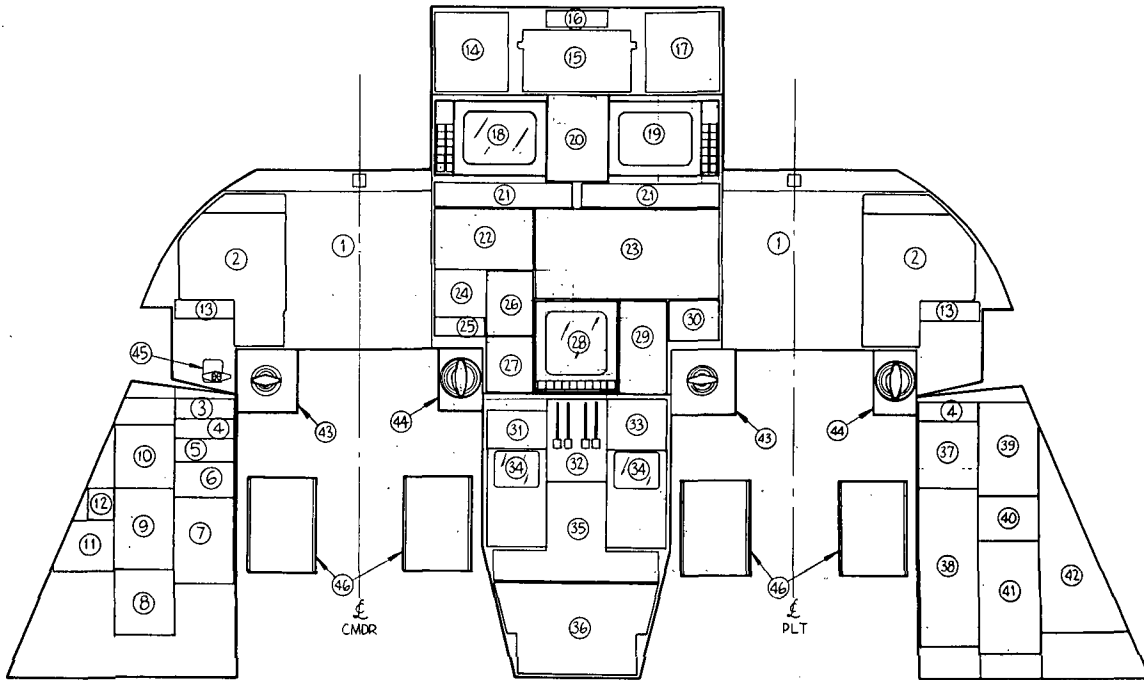

1. FLIGHT INST PNL
2. FLIGHT INST PNL (SPACE MODE)
3. EXT. ENVIRONMENT
4. TTCA/ACA MODE SEL
5. TANK BATT SEL
6. EXT TANK H/O JETTISON
7. NAV/COMM PNL'S
8. INSTRUMENTATION RCDR PNL'S
9. INT/EXT LIGHTS
10. OMS/MAIN ENGINE START
11. NOSE WHEEL STEERING

12. PAYLOAD DOORS CONTR PNL
13. EVENT TIMER CONTR PNL
14. BOOSTER MONITOR
15. FIRE WARN SYSTEM
16. MISSION DISPL CONTR PNL
17. ACP'S EXPEN. STATUS
18. CRT DISPLAY #1
19. CRT DISPLAY #2
20. CABIN TEMP/PRESS
21. CAUTION ANNUNCIATOR
22. OMS STATUS/ISLN

23. AIR BRTH ENG STATUS
24. HYDRAULIC STATUS
25. ABORT PNL
26. ENG CHAMBER PRESS
27. MAIN PROPULSION ISLN
28. MICROFILM DISPLAY
29. LDG GEAR/GEAR COMP STAT/ANTI-SKID
30. AERO SURFACE POS IND/RUDDER TRIM
31. ACP'S CMD & CONTR MODE PNL
32. AIR BRTH ENG CONTR
33. SAS/CMD - AUTO PILOT

34. COMPUTER DISPLAY
35. NAV CONTR PNL'S
36. COMM CONTR PNL'S
37. FUEL CELL CRYO ISLN CONTR
38. PWR DISTRIBUTION ISLN CONTR
39. APU SYS ISLN CONTR
40. MASTER LIGHTING CONTR PNL
41. ACP'S SYS STATUS ISLN
42. ECS CONTR PNL
43. THRUST TRANSITIONAL CONTR ASSY
44. ATTITUDE CONTR ASSY

45. DRAG CHUTE CONTR
46. AERO MODE YAW + BRAKES CONTR

Common equipment have been utilized, where practical, in the orbiter and booster crew station designs. Typical examples of common equipment include flight director attitude indicators, horizontal situation indicators, air data displays, multipurpose altimeter, C-band altimeter, turn and slip indicators, engine instruments, data entry keyboards, and subsystem instruments.

MK I BOOSTER DISPLAYS & CONTROLS SUBSYSTEM

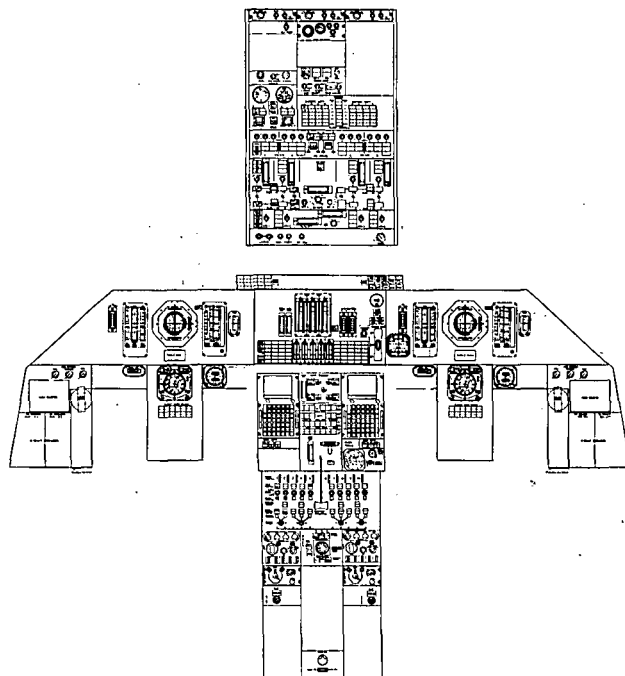

The Grumman/Boeing Mk I/II low cost baseline system designs utilize dedicated flight instruments rather than the multipurpose CRT displays previously proposed during Phase B. The rationale for this basic change evolves from the importance placed on reducing initial development costs. CRT displays, such as the EADI flight display, offer features not attainable with dedicated instruments: e.g., format flexibility, integrated primary flight data, better resolution and accuracy. Displays of the EADI type have been used in Grumman aircraft, which include the A-6A series, the F-111, and the F-14. Such a display was included in the SST design by Boeing. Of these and the many other designs which exist, none are directly suitable for a space shuttle mission. The space shuttle, because of its unique requirements, represents additional developmental costs. These costs together with pilot reluctance to accept an EADI without mechanical instrument backups makes the EADI less attractive for a low-cost development program.

SYSTEM ARCHITECTURE, MAJOR DECISIONS

DEDICATED MECHANICAL FLIGHT INSTRUMENTS VS. ELECTRONIC DISPLAYS CRT'S

ADVANTAGES

- A. Two-Man Flight Crew Feasible With Conventional Instruments (Additional Booster Simulation Required)
- B. Pilot Confidence Suggests Flight CRT Displays Be Backed Up by Conventional Instruments
- C. Minimum Development With Conventional Instruments/Parallel Development Program for CRT Displays Not Cost Effective

DISADVANTAGES

- A. Flight Data Decentralized on Several Instruments Requiring More Panel Space
- B. Reduced Display Flexibility (Scale, Format)
- C. Data Processing Required/ Instruments Can Not Be Driven Directly From Sensors in All Cases

Conclusion:

- Feasibility of an integrated two-man flight crew established

Rationale:

- All D&C'S for all flight modes physically contained in a two-man crew station
- Panel size comparable with current large aircraft aircraft
- Cockpit geometry per Mil Spec. 1333
- Total required panel area can be further reduced through optimized time-sharing of panel space for non-contiguous flight modes, i.e. orbital vs. ferry

- The use of off-the-shelf D&C hardware reduces crew training and operational task demands thru confidence and familiarity with standard equipment
- Integrated orbital/atmospheric crew station arrangement:
 - Will enhance crew operations particularly for the coordination required during the transition phase
 - Will allow a more optimized one-man emergency return capability
 - Will not constrain FHF
- Primary flight display & control techniques demonstrated by simulation

HARDWARE SUMMARY DISPLAYS AND CONTROLS

	Phase B	FHF	Mk I	Mk II
Flt Subsys Displays/ Instr	<ul style="list-style-type: none"> ● Orbiter <ul style="list-style-type: none"> - 4 CRT MDS - 16 S/S Instr - Microfilm Disp. ● Booster <ul style="list-style-type: none"> - 4 CRT MDS - 20 S/S Instr 	<ul style="list-style-type: none"> ● Orbiter <ul style="list-style-type: none"> - 54 Flt & S/S Instr ● Booster <ul style="list-style-type: none"> - 57 Flt & S/S Instr 	<ul style="list-style-type: none"> ● Orbiter <ul style="list-style-type: none"> - 82 Flt & S/S Instr ● Booster <ul style="list-style-type: none"> - 63 Flt & S/S Instr 	<ul style="list-style-type: none"> ● Orbiter <ul style="list-style-type: none"> - Min Change - 2 OBC MFD - Microfilm Disp ● Booster <ul style="list-style-type: none"> - No Change
Data Entry Display Keyboards	2 CRT/ Keyboards	None	2 CRT/ Keyboards (Simplified)	No change
Sys Config Subsys Control	Keyboards For S/S Control Sw's for Vehicle Initialization.	Dedicated Devices	No Change	No Change



HARDWARE SUMMARY DISPLAYS AND CONTROLS (Cont)

	Phase B	FHF	Mk I	Mk II
Caution & Warning	Annunciators, Master Alarm, & Tone	No Change	No Change	No Change
Primary Flt Controls	<ul style="list-style-type: none"> ● Orbiter <ul style="list-style-type: none"> - Side Arm ACA & TTCA - Pedals - Throttle Trim ● Booster <ul style="list-style-type: none"> - Side Arm ACA - Combined Thrust - Throttle Trim - Pedals 	No Change	No Change	No Change

This FHF telecommunications subsystem is required for First Horizontal Flights (FHF) to support the demonstration of vehicle performance within the atmosphere, for the substantiation of airframe performance, such as takeoff, subsonic maneuvers, low-energy approach, and landing. The flights will be conducted with the aid of chase aircraft within line-of-sight of test site telemetry and radar tracking systems. UHF voice transceivers, an S-band DFI transmitter, and C-band/L-band transponders support these functions, respectively. Landing will be conducted under VFR (visual flight rules) and is supported with the aid of a C-band altimeter and ground control using the voice link. In the event add-on requirements evolve during the FHF program (aircraft ferry to alternate test site, high energy landing, etc.), the additional telecommunications capabilities necessary – for example, area navigation – will be fulfilled with strap-on equipment.

The telecommunications subsystem adopted for FHF is common for the orbiter and reusable booster.

TELECOMMUNICATIONS — FHF

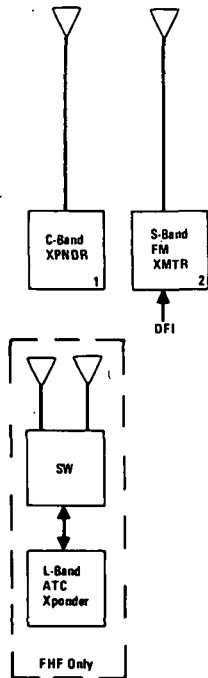

Vehicle	Key
Orbiter	- - -
Booster	• • •
Common (Orb & Bstr)	

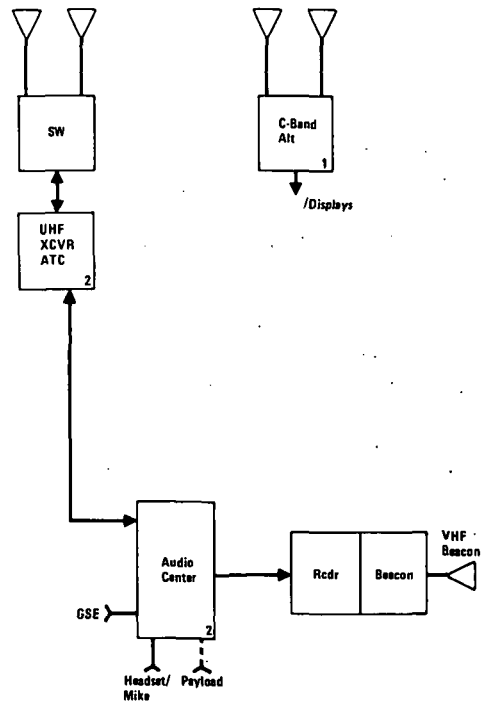

This Mk I telecommunications subsystem is for both atmospheric and space flight. Initial objectives will be a test program to demonstrate the performance of the vehicle and the Mk I telecommunications subsystems which evolve into a fully operational system. During Mk I horizontal flight tests, area navigation (TACAN), landing aid (MSB) and ATC communication capabilities will be demonstrated. These tests will be augmented with L-band ATC and C-band transponders (similar to FHF) to satisfy ground commercial and range instrumentation tracking requirements and are removed prior to Mk I FMOF.

During Mk I vertical test program, communications and ranging with MSFN will be demonstrated. Operational and DFI telemetry will be accommodated via the USB (orbiter only) and S-band FM trans-

mitter, respectively. Rendezvous ranging with cooperative targets is accomplished with TACAN (used in area navigation) in an air-to-air ranging mode.

During operational flights, the DFI transmitters can be removed; however, they have the inherent capability of transmitting TV (LCRU quality) should the requirement evolve. In addition, the inherent capability of the dual UHF ATC transceivers will allow communications with Apollo EVCS.

The Booster Mk I telecommunications subsystem is identical to the orbiter with the following exceptions: it has no unified S-band communications, includes C-band transponder for tracking, has only the C-SCAN version of the MSB system, and has two C-band altimeters.

TELECOMMUNICATIONS — FHF MARK I

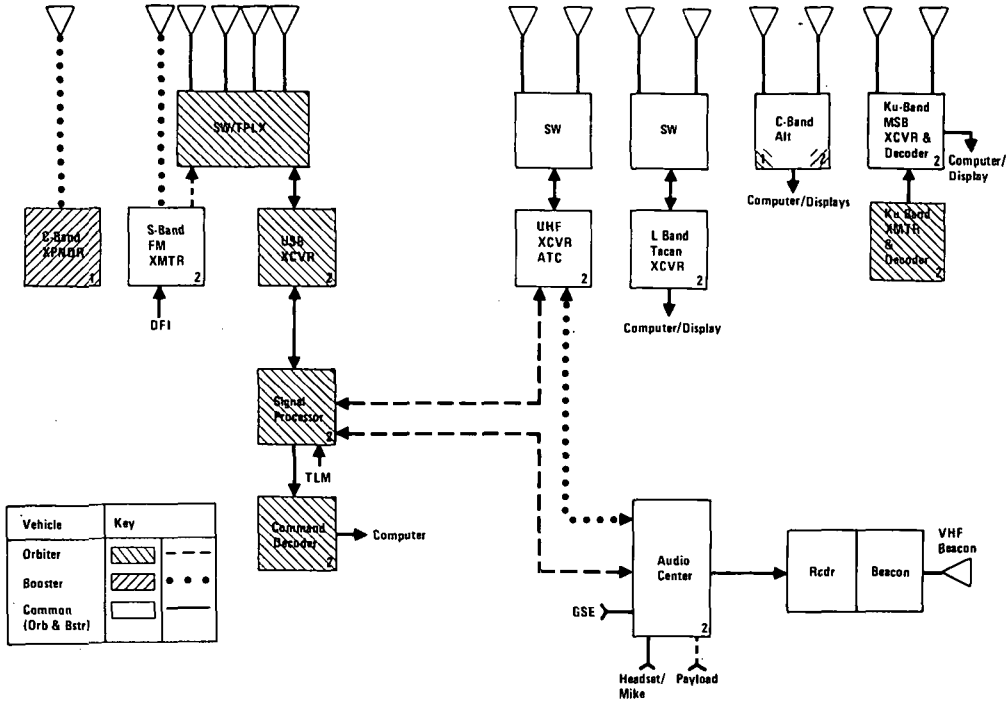

This Mk II telecommunications subsystem is for both atmospheric and space flight. Initial objectives are similar to the Mk I subsystem. The booster telecommunications subsystem remains the same as for Mk I; however, added to the orbiter is a VHF TDRS terminal and EVA capability. The later is accomplished with the UHF ATC transceiver operating in a full duplex mode utilizing a wideband secure voice channel capability.

TELECOMMUNICATIONS - THE MARK I MARK II

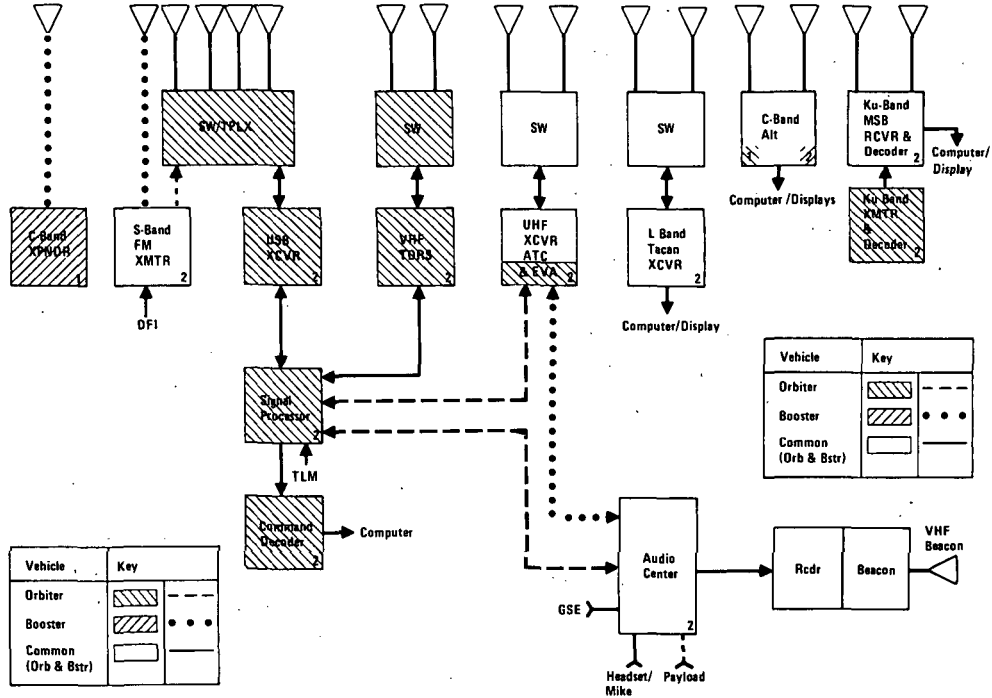

Integrated vs. Overlay DFI Telemetry

Full overlay DFI telemetry (RF hardware) was selected for the booster and partial for the orbiter. An overlay approach enables the removal of DFI telemetry antennas and transmitters from the vehicles for the operational flights. The resulting weight reduction provides increased payload capability with minimum vehicle scar. The orbiter DFI is partial overlay since its telemetry transmitter shares (frequency multiplexed) the orbiter S-band communications antennas. This approach minimizes orbiter antenna quantities and enables multifunction considerations for this transmitter during operational missions; for example, TV or payload support.

Area Navigation/Landing Aid

Of the several area navigation/landing aids compared, the TACAN/Microwave Scanning Beam (MSB)

combination was selected. Primary reasons for this decision is that both equipments are available, provide adequate performance, do not depend on complex software processing, and enhance pilot confidence because of existing similar applications.

TACAN is a multifunction equipment (used in a rendezvous mission) and interfaces with numerous existing ground and shipboard stations located throughout the world.

The MSB has been demonstrated in high glide-slope and flared landings, both applicable to the shuttle, and is functionally compatible with the FAA microwave landing system (MLS).

Rendezvous Ranging Aid

TACAN was selected as an rf rendezvous aid because it has existing air-to-air ranging capability, is multifunction (area navigation), has adequate performance, available off-the-shelf hardware, and relatively low cost. Furthermore, it has been demonstrated in military aircraft refueling operations in the air-to-air ranging mode and incorporates existing digital interfaces.

SYSTEM ARCHITECTURE, MAJOR DECISIONS: TELECOMMUNICATIONS

KEY ISSUE

- **Integrated vs Overlay DFI Telemetry**
- **Area Navigation/Landing Aid—TACAN/MSB vs PRS vs VOR/DME/ILS vs Ground Precision Radar**
- **Rendezvous Ranging Aid—TACAN vs S-Band vs ATC vs PRS**

DECISION

- **Overlay**
 - Payload Advantage
 - Minimum Scar
- **TACAN/MSB**
 - Minimum Risk
 - Pilot Confidence
 - Computer Decoupled
 - Demonstrated
- **TACAN**
 - Multi-Function Use
 - Demonstrated (Mil) Applications
 - Adequate Range, Accuracy

Orbital Communications/Navigation

Unified S-Band (USB) and VHF TDRS communications/navigation with the ground were considered. Based upon the use of existing ground MSFN facilities, which is assumed not chargeable to the shuttle program and proven capability, the USB was selected for Mk I.

The implementation of the USB equipment considered transceivers from the LM, CSM, ERTS, and SGLS programs. Selection of the LM transceiver was made because it is available in the existing inventory (which minimizes program cost), fully compatible with the signal processor, man-rated, and satisfies link margins without a power amplifier. The Mark II avionics will have an interface with the TDRS at VHF. This will be the primary link to the ground while the USB will be a backup, since MSFN is expected to phase down. The VHF TDRS terminal will allow narrow-band voice or data transmission and turnaround ranging from the ground. Should wideband data or TV be required through the TDRS, then a Ku-band terminal is necessary.

Antennas/Radomes

Three key issues related to antennas/radomes are flush-mounted versus protruding, high versus moderate temperature antennas, and ablative versus re-

usable radomes.

Flush-mounted antennas are selected for both the orbiter and booster because they have the minimum impact on the vehicle thermal protection system, result in no aerodynamic drag, and require less maintenance.

Moderate temperature antenna designs, with high-temperature insulating radomes, are utilized since they enable the use of conventional materials and existing design techniques. The vehicle thermal protection system design requirement to protect the bondline of the vehicle aluminum structure to a maximum temperature of 300° F may enable the use of modified off-the-shelf antennas.

The radomes (rf windows) selected for Mk I orbiters are ablative (SLA-220) types because they are compatible with the vehicle ablative (SLA-561) TPS. Ablative radomes are low risk because they have been successfully used on numerous reentry vehicles at heating rates equal to and much greater (>10 times) than those expected on the space shuttle. The radomes for Mk II vehicles will be ceramic types similar in material to the vehicle's Mk II external insulation TPS. The booster radomes may be identical to the orbiter if cost studies for detail designs show that common antennas/radomes are cost effective.

SYSTEM ARCHITECTURE, MAJOR DECISIONS: TELECOMMUNICATIONS

KEY ISSUE

- **Orbital Communications/Navigation—S-Band USB vs TDRS**
- **Antennas/Radomes Flush Mounted vs Protruding High/Moderate Temperature With Ablative/Reusable Radomes**

DECISION

- **S-Band USB (Mk I)**
 - Utilize Existing Ground Facilities
 - Proven
 - Low Cost
- **Flush Mounted, Moderate Temp Ablative Radomes (Mk I)**
Reusable Radomes (Mk II)
 - Compatible with TPS
 - Existing Design Techniques

This diagram shows bulk power transmission circuitry and switching requirements only and does not indicate power distribution/control/protection to utilization equipment; nor does it indicate the necessary control-logic/control-circuitry or protective functions incorporated for source, source transmission line and bus protection. The use of the circuit protector symbol (Δ) does not necessarily indicate a specific type of protective device (thermal/magnetic circuit breaker, remote control circuit breaker, fuse, limiter, solid-state power controller etc.) but serves to indicate a requirement for circuit protection at that point.

During ground operations, 115/200V-3 ϕ -400 Hz power is supplied through an external power receptacle at the external power panel. The external power panel includes an External Power Monitor (XPM) which monitors external power quality (voltage, frequency, phase sequence etc.) and supplies power for the external power contactors. Since the external power contactors can only be energized by external power, during flight operations the EPS is configured into two essentially independent systems that are physically, electrically, and thermally isolated so that single or multiple faults occurring on one system will not affect or be propagated to the other system. Alternating current power sources are not paralleled, since paralleling involves additional circuit complexity and switchgear/protection requirements which tend to degrade reliability. Since paralleling circuitry is not provided, inadvertent paralleling is avoided in the design and implementation of the system control logic.

A Generator Control Unit (GCU) is provided for each generator, which:

- Monitors and controls the generator output
- Provides for generator protection in conjunction with current-transformer packages
- Provides for generator transmission line and bus fault detection and protection in conjunction with current-transformer packages
- Provides power for operation of the associated generator contactors

Each fuel cell is controlled by a Fuel Cell Control Unit (FCCU) which:

- Monitors and controls the operation of the fuel cell
- Provides protection for the fuel cell, fuel cell transmission line and fuel cell lines in conjunction with line current sensors
- Provides power for operation of the associated fuel cell contactors



The inverters (Inv 1, Inv 2) are integrally monitored, controlled and protected. They also provide power for operation of the associated contactors. Inverter line and bus protection is provided by line current-transformers in conjunction with associated time delay/logic circuitry.

Transformer-rectifier (T-R) output voltage is monitored by its associated contractor which will not pick-up unless the T-R output exceeds the minimum specified voltage. T-R bus fault protection is provided by line current sensors with associated time delay/logic circuitry.

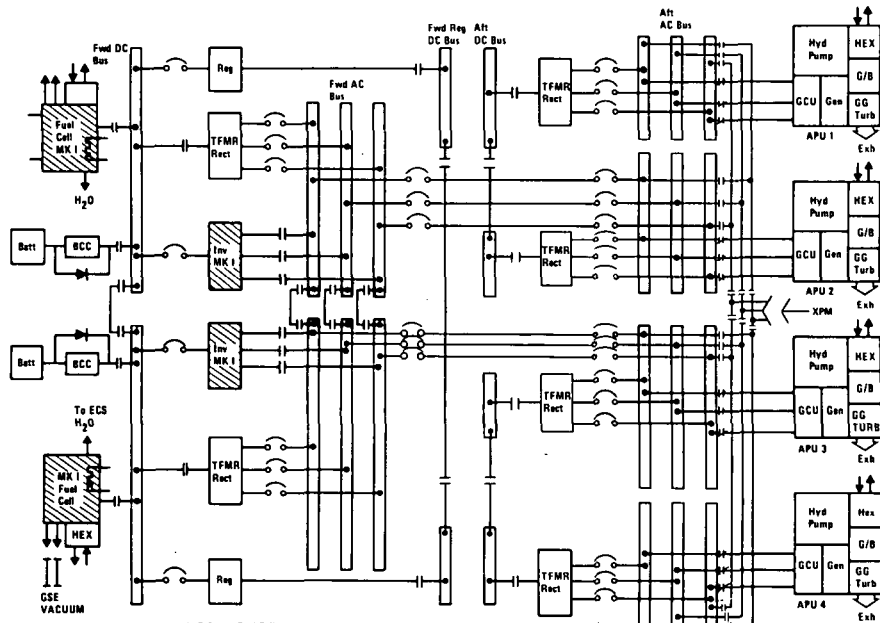
POWER SYSTEM -



Note: For FHF Delete Fuel Cells and Inverters

Vehicle	Key
Orbiter	 - - -
Booster	 . . .
Common (Orb & Bstr)	 - - -



The baseline power generation subsystem (PGS) for the orbiter satisfies the total electrical and hydraulic power requirements of the onboard system and subsystem utilization equipments with FO/FS system redundancy. The PGS consists of a combination of power sources, i.e., fuel cells, auxiliary power units (APU), and batteries. The fuel cells supply prime electrical power during orbital operation. The APU's supply electrical and hydraulic power during the transitional phases, both proceeding and after the orbital phase. The batteries are utilized to provide emergency electrical power during all mission phases. Electrical and hydraulic power for the ferry mission is supplied by the APU's modified for JP/air operation. Each fuel cell is sized to supply the total vehicle load

during orbital operation so that the mission is not affected by the loss of one fuel cell. In the event of loss of both fuel cells; the APU's are activated and electrical power is supplied by the generators through a power cross-tie between the forward and aft busses. Each generator is sized for total vehicle load.

Utilization of ac generators permits minimum conversion losses due to the high percentage of ac power required.

Hydraulic power is generated by constant speed, variable displacement pumps driven by the APU turbine. Each of the four APU's drive two pumps, with a total of four pumps required for safe return. The hydraulic system pressure is 3000 psi.

ELECTRICAL POWER SYSTEM BASELINE

- Two H_2/O_2 Fuel Cells @ 28vdc, 7 KW Continuous/10KW Peak (Fwd Fuselage) (Note Below)
- Two Secondary Ni-Cd Batteries @ 28 vdc, 36 AH (Fwd Fuselage)
- Four N_2H_4 Aux Power Unit (APU) Generators @ 115/200 vac, 3 Phase, 400 Hz, 15 KVA (Aft Fuselage).
- Dedicated Apollo CSM Cryogenic Tanks for Fuel Cell H_2 and O_2 and EC/LSS O_2
- Dedicated Titan IIIC N_2H_4 Tanks With LM A/S Helium Tanks for Pressurization
- Power Transmitted at 115 vac and Power Distributed to Loads at 115 vac and 28 vdc
- Power Conditioning - Max Use of Existing Commercial/MIL/Space Equipment, Located in Pressurized Cabin Area
- Power Control - Max Use of Conventional Electromechanical Switches, Relays, Circuit Breakers, etc.

(Note: Mk I - 2000 Hr Life: Mk II - 5000 Hr Life)

The primary electric power system for the orbiter is significantly different from conventional aircraft and/or spacecraft power systems. These differences result from the nature of the vehicle mission and the requirement to reduce the possibility (and the rate of occurrence) of total loss of electric power during any mission phase - with emphasis on the minimization of even momentary power interruptions during critical phases of the mission.

Electric power is derived from three distinct power source systems:

- For ground operations, 115/200V-3 ϕ -400 Hz power is supplied from external source (s)
- During all flight phases, except orbital operation, 115/200V-3 ϕ -400 Hz power, conforming to MIL-STD-704A, is supplied by APU driven generators

- During orbital operations, 28 vdc power is supplied by H₂/O₂ fuel cells, with Ni-Cd batteries for emergency and peak power requirements

Hydrazine APU fuel is stored in dedicated Titan III C RCS tanks. Pressurization for the APU fuel tanks is provided with high pressure ambient storage of gaseous helium. Three LM A/S helium tanks are utilized for this purposes. The APU's and APU fuel and pressurization storage are located in the aft section, behind the payload module.

The H₂ and O₂ reactants for the fuel cells are stored in dedicated cryogenic tankage. Four hydrogen and three oxygen Apollo CSM tanks provide the total fuel cell requirement in addition to the EC/LSS oxygen requirement. The fuel cells, fuel cell reactant storage and batteries are located in the forward fuselage, aft and below the pressurized compartment.

POWER GENERATION - KEY FEATURES

- **APU's Supply All Electrical and Hydraulic Power During All Mission Phases Except Orbital Operation**
 - Fuel Cells Sized for Orbital Load
- **Four APU's @ 210 shp Each**
 - Two 45 gpm Pumps and One 15 KVA Gen per APU
 - Hydrazine Monopropellant APU
- **Two Fuel Cells @ 7 KW Each**
 - Mk I Shuttle Fuel Cell
- **Two Secondary Ni-Cd Batteries**
 - 36 AH Skylab A/M Battery

SOFTWARE

This chart depicts the flow of events in the development cycle for the vehicle flight software and is an idealization of the shuttle flight software project. The timing and phasing of the critical reviews - PRR, PDR, CDR and FSRR, and their relationship to other major project events are shown. The Software Development Plan outlined is idealized in the sense that the shuttle flight software will be implemented with a phase development. Software will be developed for First Horizontal Flight (FHF) and for Mk I and Mk II Manned Orbital Flights. For each of these software developments, there is a set of the above reviews and the associated project events.

One significant review is the Preliminary Design Review (PDR). This review is involved with obtaining the concurrence and approval of the preliminary software design. Preliminary software design must be based on stable functional requirements, algorithms, and control laws, etc. The availability of stable functional requirements at this stage of the program is a prerequisite to an orderly software development. Final software design is concluded with the Critical Design Review (CDR).

The preliminary scheduling of these major reviews for the phased flight software development are indicated.

SOFTWARE DEVELOPMENT PLAN

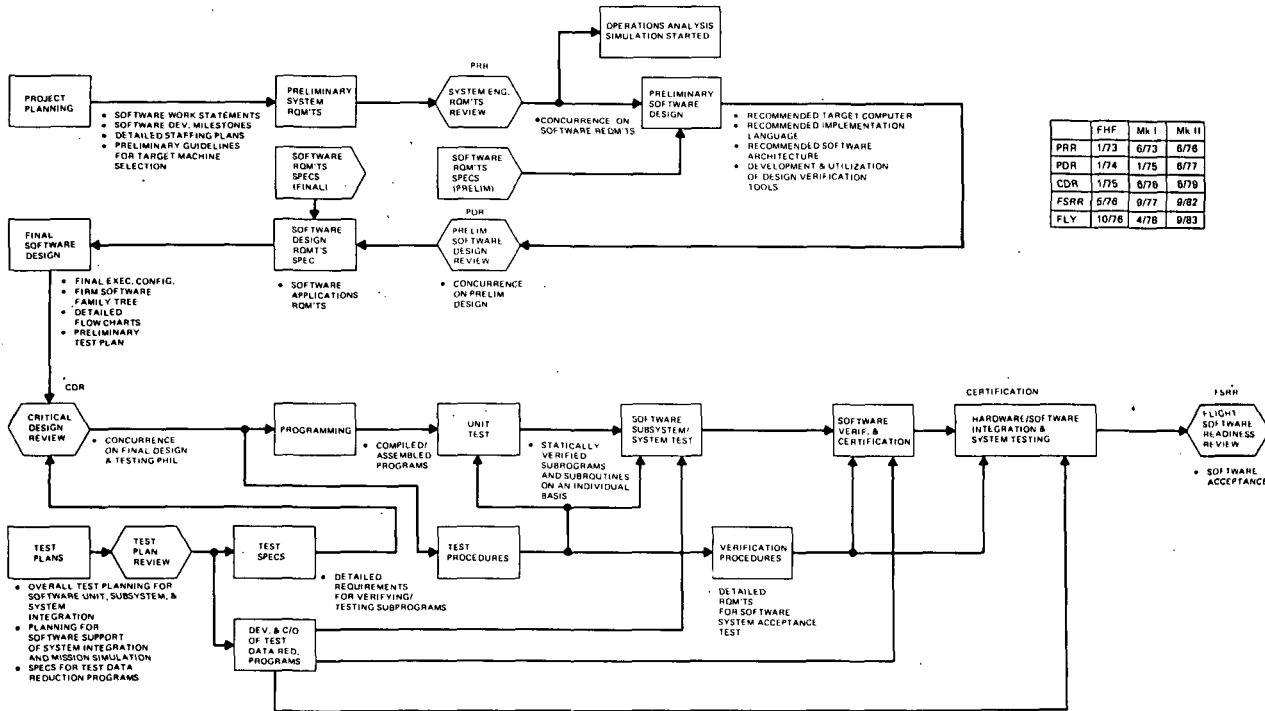

Successful development of the Space Shuttle software requires a comprehensive management effort. The shuttle software for the low-cost avionics system is a multi-project operation demanding control and visibility of all software elements.

To ensure technical, cost, and development success for the Shuttle Program, it is necessary for all these projects to be properly coordinated and managed.

The accompanying chart indicates some of the planning factors that must be considered in drafting detailed management plans for the Phase C/D efforts. In the future, these planning factors will be categorized into immediate and long-range management tasks. The creation of the Software Management Plan will be an iterative process reflecting the level of detail required at various stages in the software development cycle.

SOFTWARE MANAGEMENT PLAN

- Identification and Definition of Major Software Elements
- Identification of Contractor, Associate Contractors and Subcontractors for Shuttle Avionic Software Development
- Software Element Interface and Commonality Management Plan
- Identification of Government Resources to Be Applied to Program. Coordination of All Program Resources Between Government, Contractor, Associate Contractors and Subcontractors
- Monitoring of Various Software Development Activities
- Status Reviews and Progress Reporting System
- Acceptance Testing and Software Certification of Individual Software Elements
- Software System Integration Plan for Avionic Software Elements, i.e.,
 - Phased Integration of On-Board Software Through ASDL and IATL
 - Integration With Pre-Flight Ground Support Software
 - Integration With Post Flight Ground Support Software
 - Integration of Flight Test Software
- Certification of Flight Software
- Post Acceptance Support
 - Configuration Control
 - Documentation Control
 - Operations Software Maintenance
 - Identification of Government Resources Committed to Post Acceptance Maintenance
- Identification of Critical Milestones for All Major Software Elements

The Software Development Flow Graph indicates the role of simulation and test facilities in the software development. The Shuttle Program requires specialized real-time and non-real time software to perform the following functions:

- Non-real time software to develop, verify, and modify algorithms and control laws
- Real-time software to functionally verify the control laws in a simulation environment (Full Mission Simulation Laboratory - FMSL)
- Non-real time interpretative simulation software to assist in flight program coding and debugging (Avionics Software Development Laboratory, ASDL)
- Real-time software to verify the hardware/software interfaces on a subsystem functional level (Integrated Avionics Test Laboratory, IATL)

The flight software development process from

algorithm development to end-item delivery is an iterative process as illustrated in the chart. The significant point of the graph indicates that in order to avoid the major "glitch" path, emphasis should be given to development of stable algorithms, verified control laws, and a validated ASDL facility before the "code/debug" effort commences. The phased flight software effort (for FHF, Mk I and Mk II) will greatly increase the likelihood of achieving this goal in that modular software development phasing will minimize the major software glitch prospect.

NOTE:

Software Development cost figures, i.e., \$17.5M for algorithm and control law verification and \$19.2M for development and verification phases. Total Mk I software costs of \$36.7M are exclusive of facility equipment costs and operating personnel, but rather refer to costs associated with software efforts only. Mk II software efforts add \$10.7M for OBC and MCC software efforts required.

SOFTWARE DEVELOPMENT FLOW GRAPH

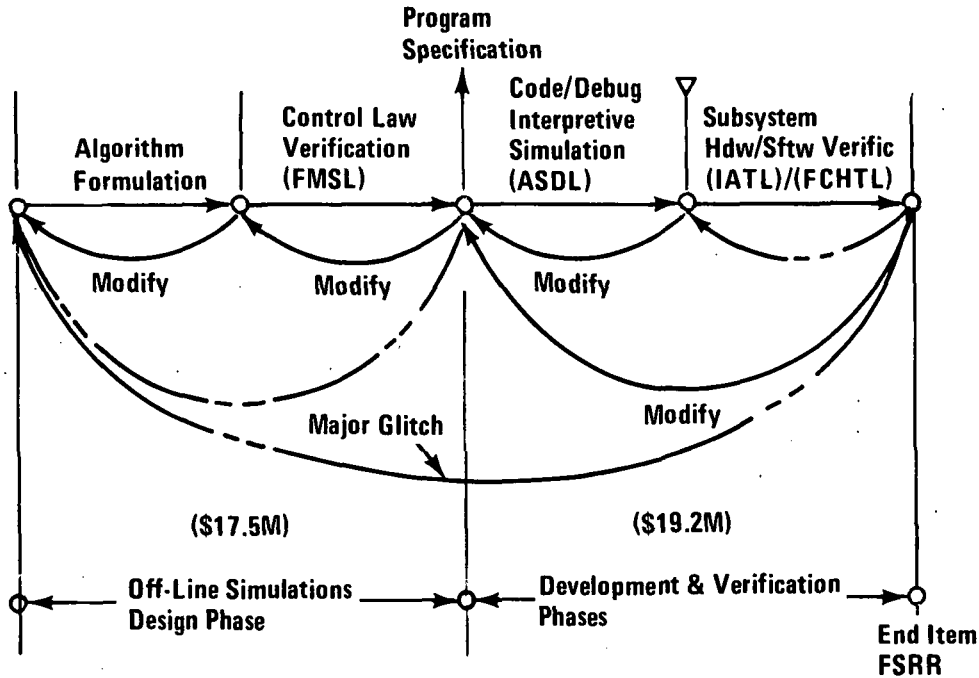

The Avionics Software Development Laboratory (ASDL) will be required for flight software development and verification. Software verification includes software-to-software and software-to-flight computer integration and precedes the subsystem/system integration effort utilizing the IATL.

The ASDL facility actually contains four functional areas-one for each of the following flight software development efforts:

- Air Data Computer Flight Software
- Flight Control Computer Flight Software
- Data Acquisition Computer Flight Software
- Primary Computer Flight Software

Though not baselined as a result of this study, the following additional ASDL capabilities will be investigated for ASDL application:

- Commercial time-shared computer

- Terminals with interactive operations

Such capability may be particularly effective for the detailed module coding and debugging stage where it can be assumed that many coding tasks are being carried out concurrently by many individuals. Programmer effectiveness is enhanced by significant improvements in turnaround time. Extensive utilization of such a capability during software integration and test, in conjunction with a full simulation capability, is an area of further investigation.

Functionally, the ASDL facility will contain:

- Programming languages and assemblers/compilers
- A software simulation system (i.e., Digital Simulation Software Support System)

The utilization of a high level language compiler will apply to the Primary GN&C flight software only.

FLIGHT SOFTWARE DEVELOPMENT AND VERIFICATION FACILITY NEEDS (ASDL)

Programming Language & Compiler

- **Code Generators for Flight & Ground Computers**
- **Compile Time Diagnostics, Compile Control Cross Reference Listings**

Flight Software Development Facility

- **Commercial Time Shared Computer**
- **Terminals With Interactive Operation**
- **Software Simulation System**

The Digital Simulation Software Support System will vary in capability with each ASDL functional area. The chart shows the general capabilities required for the ASDL to be utilized for the Primary GN&C flight software effort. The ASDL functional areas will require the same general capabilities with varying levels of detailed complexity appropriate to each particular flight software effort.

The next step in establishing the detailed capabilities of the ASDL will be to investigate available support software, particularly in the areas of the "flight computer instruction simulation" and the "run time diagnostics and debugging aids". Not only will the availability of support software be an important selection criteria for the onboard flight computers but also the selection of the "host" ground computer for execution of the "Digital Simulation Support System". Implicit in the investigation of support software will be a trade study to establish the cost and schedule advantages of a Decentralized vs. Centralized ASDL facility to support the four flight software efforts.

DIGITAL SIMULATION SOFTWARE SUPPORT SYSTEM (ASDL)

- **Flight Computer Instruction Simulator**
- **Run Time Diagnostics & Debugging Aids**
 - Edited Dumps
 - Source Language Trace
 - Timing Checks
 - Breakpoints
- **Environment Simulation**
 - Vehicle & Aerodynamic
 - Universe
 - Subsystems Interfaced to Primary Computer, Other Computers, IMU, Displays, Controls
- **Functional Simulation of Computer Interfaces**
 - Air Data, Incremental Digital Control, Data Acquisition
- **Simulation Test Generation Support Software**
- **Recording & Post Run Editing Support Software**

To appreciate and properly utilize the costs indicated on the chart, it is necessary to understand the groundrules and constraints that apply.

Rather than initially presenting an all inclusive Flight Software cost figure, it is perhaps more advantageous to start with the costs for the code/debug effort first.

The projected cost of onboard code/debug software effort (for FHF and Mk I) is \$6.3M. However, this estimate assumes the ideal conditions of well-defined algorithms and control laws at CPCEI Part II approval and additionally, that no major changes causing software redevelopment will be imposed during the development cycle. However, experience indicates that total software development costs, in many cases, approach almost twice the an-

tipated development costs under ideal conditions.

This cost estimate reflects only the coding/debugging and the related costs of production and operations phases for FHF and Mk I and does not include algorithm development, control law verification, ASDL and IATL software build-up costs.

The estimates were based on the following software development efforts:

- For FHF: The Air Data, Flight Control and Data Acquisition flight software efforts
- For Mk I: The Primary GN&C software effort and the Data Acquisition flight software effort associated with enhanced on-board checkout processing.

ONBOARD SOFTWARE COST SUMMARY, \$K (FHF and MK I)

● Avionics	
Programming	2,400
Production	900
Operations	3,000
<hr/>	
Total	6,300 (Idealized Cost)

- Assuming Stable Verified Control Laws
- Computer Machine Costs Not Included
- Algorithm Development Not Included
- Control Law Verification Not Included
- Software Development Experience Factor (Multiply Ideal Cost by 2)

The estimated cost of total avionics software development exclusive of GSE related software is \$47.4M. This does not include the costs associated with computer hardware or machine time utilization. The estimates were based on the following software efforts (as related to the development cycle):

- The development, verification and modification of algorithms and control laws using non-real time software techniques
- The functional verification of control laws utilizing real-time software techniques in a simulation environment (i.e., the build-up and utilization of a Full Mission Simulation Laboratory, FMSL)
- The code/debug flight software effort including:
 - FHF and Mk I
 - Mk II software development which is an incremental increase from Mk I incorpora-

ting significant additional OBC functions and mission management functions to be mechanized in flight software

- Flight software verification/certification utilizing the Integrated Avionics Laboratory (IATL). The IATL costs reflect IATL build-up and flight software verification/certification
- Flight test software will be required during the shuttle “flight test” program to aid in evaluating and/or demonstrating the avionics systems under test. Although the definition of the shuttle reduction requirements has not been established, it was possible to generate a possible software estimate based on solid E-2C experience (a total avionics system was evaluated on this program) and the F-14 instrumentation system.

AVIONICS SOFTWARE COST MATRIX, \$K

Category	
● Onboard Software (6,300 X 2)	\$12,600
● Avionics Software Development Lab (ASDL)	3,420
● Integrated Avionics Test Lab (IATL)	2,280
● Flight Test Software	925
Subtotal (FHF, Mk I)	19,225
Subtotal (Mk II)	10,700
● Algorithm Development	17,500
● Control Law Verification	
Total Software	\$47,425
● Computer Machine Costs Not Included	
● Facilities Operating Personnel Not Included	
● Flight Test Includes Only Avionics System Testing	

Memory size estimates of the GN&C baseline software functional components with estimates of the storage impact on the Primary computer were based on actual figures taken from an Apollo Command Module Computer Program. The estimates for the corresponding shuttle Primary computer program are rounded to the next 500 words; each word represents an equivalent AGC word of 15 bits plus parity. The estimates as presented were derived by comparing the equivalent Apollo and Orbiter GN&C functions and making a positive or negative adjustment to the Apollo word count depending on a judgement of the scope and complexity of the shuttle function.

SIZE AND SPEED ESTIMATES

Based on 15-Bit Word Size

Mission Control Programs

	<u>AGC</u>	<u>GN&C</u>
● Prelaunch	580	1000
● Boost	480	2500
● Orbital Coast	9090	9500
● Rendezvous	2080	4500
● Deorbit	3030	3500
● Transition & Landing	—	2500

General Purpose Programs

● Orbital Mechanics	4010	5000
● Navigation	930	1500
● Digital Autopilot	4090	7000
● System Function	12410	11000

	<u>36700</u>	<u>48000</u>
--	--------------	--------------

Variables

	2050/ 38750	4500/ 52500
--	----------------	----------------

Before the memory estimate of the previous chart can be extrapolated into real memory requirements, several additional factors must be taken into consideration:

- It is recommended that the Primary Computer tasks be implemented in a Higher Order Language. This is likely to result in a 20%-40% increase in the volume of machine code over an all-assembly language approach
- The Apollo program is the result of a long period of development during which the AGC's limited memory and execution time were fully exploited. A shuttle memory size estimate should add another 10%-20% over the equivalent Apollo word count to allow for this fact (i.e., the shuttle Primary computer will not have limited memory and size restrictions)

- A pad must be added to any software estimate derived from such a comparison as assumed here. A 25%-50% increment should be allowed after the above efforts have been accounted for

Accounting for the 32-bit word length, as recommended, will decrease the word count 50%-60% of the extrapolated 15-bit total, due to half-word instruction and floating-point arithmetic economics.

It should be noted that although 50K, 32-bit words are baselined for Mk II the resident on-board GN&C program will be somewhat reduced. This is accomplished by utilizing overlay techniques with serial execution of the various mission phases. This technique will also be used for the enhanced Mk II onboard checkout (OBC) and the additional mission control processing (MCC) required. Serious consideration for mass memory in the Mk I baseline is under study in order to provide overlay processing of Mk I GN&C functions as well as enhanced OBC processing.

SIZE AND SPEED ESTIMATES (CONT)

Modifying Factors

● HOL Implementation	15,000
● Non-Optimum Code Sharing	5,000
● PAD	<u>20,000</u>
	40,000

Total: Function Sizing Plus Modifying Factors

52,500
40,000
92,500

15-Bit Words

Accounting for 32-Bit Word Implementation

Equivalent Words: 46,250 (Half as Many Words, Twice as Many Bits)

Inefficiency Factor: 5,000
51,250

Grand Total 50,000 32-Bit Words

The period just prior to landing may present the most critical speed loading requirement for the computer. At this time the computer may be required to perform all of the following four functions.

- Correct Position, Velocity by Incorporating Radio Data - Assuming an eleven state filter and an update interval of 5 seconds, 30,000 fixed-point equivalent adds (E-adds) per update was estimated for the computational burden. Accounting for the once per five second duty cycle yields 6,000 "E-adds" per second.
- Processing of IMU Data - The Delco Magic III computer has approximately the same add speed, but half the multiply speed, as the AGC. We presume that it is 80% as fast as the AGC. In processing Carousel data it runs at about 75% duty cycle. The AGC can process about 44,000 "E-adds" per second. We therefore estimate that the processing of IMU data will require:

$$.8 \times .75 \times 44,000 = 27,000 \text{ "E-adds"/second}$$

- Computation of Desired Heading, Elevation, and Roll, and Control of Pitch, Yaw, and Roll Rate- Based on AGC experience, it is reasonable to expect an update rate of ten per second and a doubling in complexity. These functions, therefore, are estimated to require about 20,000 "E-adds" per second.
- Computations for display should not require more than another 10,000 "E-adds" per second.

Totals	Item 1	6,000
	Item 2	27,000
	Item 3	20,000
	Item 4	<u>10,000</u>
		63,000 (Fixed-point equivalent adds per second)

COMPUTER SPEED REQUIREMENTS

Period Just Prior to Landing

TASKS

- Item 1 Correct Position, Velocity by Incorporating Radio Data
- Item 2 IMU Data Processing (One IMU Only)
- Item 3 Compute Desired Attitude, Attitude Errors
- Item 4 Display Desired Attitude, Attitude Errors

Floating-point operations, if performed by hardware, are typically about twice as slow as single-precision fixed-point adds. Algorithm implementation, utilizing floating-point operations, degrades approximately 10% when attendant fixed-point operations are accounted for, based on a preliminary analysis using the IBM 4 π AP-1 characteristics. However, the estimates for items 2, 3 and 4 (below) involved extrapolating computation time based on executing similar computations in other computers. It is likely that only 50% of the operations in items 2, 3, and 4 will actually involve operations that should be done in floating-point. Item 1 on the other hand should be done essentially completely in floating-point. Therefore, to extrapolate to a machine that executes floating-point arithmetic at about a 10% speed disadvantage, the following table estimates the fixed-point equivalent adds per second speed requirement: (reference chart)

Item 1	6,600
Item 2	28,350
Item 3	21,000
Item 4	10,500
Total	66,450 (fixed-point equivalent adds per second)

Finally, based on the aforementioned preliminary

analysis, software floating-point is about 10 times slower than fixed-point arithmetic operations. In this case, the numbers would total as follows:

Item 1	60,000
Item 2	135,000
Item 3	100,000
Item 4	50,000
Total	345,000 (fixed-point equivalent adds per second)

We now invert these numbers to obtain the fixed-point add time required for the shuttle computer:

- Case 1 - Everything in fixed-point arithmetic
16 microsec. add time
- Case 2 - Floating-point hardware
15 microsec. add time
- Case 3 - Floating-point software
3 microsec. add time

Floating-point hardware is, therefore, baselined for the Grumman/Boeing Avionics System. Although the above analysis is somewhat immature, it clearly shows a significant margin of safety in computer timing utilization (approx. 15% utilized).

COMPUTER SPEED REQUIREMENTS (CONT)

TOTALS

Case 1: All Fixed Point Operations

16 μ sec Fixed Point Add Time

Case 2: Floating Point Hardware

15 μ sec Fixed Point Add Time

Case 3: Floating Point Software

3 μ sec Fixed Point Add Time

During the study period, Grumman investigated the technical and cost benefits that would be derived from utilizing several cost reduction techniques. The net effect of these measures is implicit in the cost analysis.

The following charts summarize the technical aspects of these cost reduction measures considered during the study.

AVIONIC SOFTWARE COST REDUCTION ANALYSIS

- **Centralized/Distributed Computer Systems**
- **Application of High Order Language Compiler.**
- **Application of Floating Point**
- **Software Cost Drivers**
- **Software Development Risks**

In the course of the Avionics Study, several computing configurations were examined. The system selected and baselined is distributed with four computing centers, as follows:

- Primary Computer (PC). The navigation, guidance, and control computations, sensor processing, OBC and mission control functions
- Air Data Computer (ADC). The air data sensor processing
- Flight Control Computer (FCC). The digital flight control and inner loop autopilot functions
- Data Acquisition Controller (DAQC). Reasonableness tests and limiting checking of data from remote acquisition units.

The distributed approach was selected based on the groundrule of phased development (FHF, Mk I and Mk II) and advantages obtained in minimizing peak annual funding.

The technical rationale leading to the choice of a distributed system is as follows:

- The distributed system leads to a high degree of software modularity in that separate functions are virtually self-contained
- The separation of the computing functions into distinct computers permit a higher degree of verification independent of system integration

- Separation of functions forces early definition of system interfaces which can lead to overall cost savings
- The distributed approach permits better management visibility on cost and schedule matters
- The distributed system is highly compatible with the phased approach to avionics development.

The following advantages of the centralized approach were assessed from the viewpoint of compatibility with the groundrules of the low-cost avionics study:

- More flexibility and adaptability to change is offered by a centralized system. In a distributed system, the major interfaces are cemented in hardware
- A greater burden is placed on the systems integration function
- Less equipment is added to the vehicle which leads to a lesser number of failure modes and "back-up" cases.
- A pitfall of defining system interfaces before system requirements, which can happen with distributed systems is avoided with the centralized approach.

CENTRALIZED/DISTRIBUTED COMPUTER SYSTEMS SOFTWARE IMPACTS

- **Distributed System Selected**
 - **Air Data Computer**
 - **Incremental Flight Control Computer**
 - **Data Acquisition Computers**
 - **Primary On-Board Computer**
- **Rationale**
 - **Software Development Management Is Improved by the Separation of Disciplines Into Specialized Groupings**
 - **Software Fault Isolation Is Enhanced During System Checkout and Verification**
 - **Distributive Approach Permits Parallel Development of Separated Avionic Functions**

The use of a higher order compiler language (HOL) is baselined for Shuttle software development. Primary reasons for this recommendation are: 1. to enhance communications among many contributors, cooperating toward a common goal, and 2, to reduce the amount of necessary verification by preventing the occurrence of certain classes of errors in the first place. Both reasons contribute significantly to a reduction in overall software development costs.

An Improvement in Communications

In this context communications are meant to include requirements and specifications, descriptions, all forms of documentation, methods of configuration and change control, management visibility and the technical exchanges, written and oral, that must occur among engineers, analysts, and programmers. Additional significant factors are included on the chart.

Reduction in Verification Effort

The production of software can be divided into two phases: preparation and verification. Any method which can ease the verification burden will reduce overall cost and improve reliability. An

organized approach to the prevention of errors is such a method, and a HOL can be instrumental in prevention. That this assertion is true can be seen by comparing the probability of error when using assembler and compiler coding techniques. Additional major advantages of a compiler language are the ability to perform extensive checking at compile time and the opportunity to structure and modularize programs.

Compiler Disadvantages

The skilled assembly programmer produces better assembly language code than HOL would in the original coding phase. But, following the inevitable patching of programs during first system checkout, the HOL (which regularly recompiles the model) generated Code has suffered less deterioration in coding efficiency. The overall effect is that HOL program efficiency is not appreciably degraded compared to assembly language program. Typically, real-time control and I/O interface programs require special code to function effectively. HOL is not well suited for this purpose. Therefore, real-time systems coded in HOL will inevitably have assembly language sections.

HIGH ORDER LANGUAGE COMPILER APPLICATION

- **Advantages of Higher Order Language Compiler:**
 - **Clarity and Readability of Higher Level Language Improves Communications Between Problem Definers, Software Designers and Programmers**
 - **Better Enforcement of Standards and Conventions**
 - **Better Documentation (Automatic Flow Chart Generators)**
 - **Easier to Learn, Write, Understand, and "Think-In"**
 - **Easy to Modify and Debug - Better Detection of Problems and Clerical Errors**
 - **Operate on System Model at a Higher Level of Abstraction**
 - **Easy to Vary System Model**
 - **Reduction in Verification Effort by Elimination of Certain Errors**
- **Disadvantages:**
 - **All Real-Time Control Module Can Not be Written Completely in a Higher Level Language**
 - **Programmer is Usually Prohibited From Applying Whatever Knowledge He Might Have of the Object Machine**
 - **Efficiency of Object Code Execution Usually Lower Than Assembly Language**

During the course of the study, the utilization of floating-point vs fixed-point computation was examined. Implementation of fixed and floating-point was evaluated by examining hardware and software mechanizations.

The results clearly indicate that cost reduction (approximately 10%) is obtained by utilizing hardware floating-point for the Primary computer. Floating-point hardware was selected over software based upon the timing utilization advantages offered.

Emplementation of a high order language compiler is also improved by the availability of floating-point instructions in the object computer.

FLOATING POINT APPLICATION

- **Advantages of Floating Point Arithmetic:**
 - **Scaling Analysis Greatly Eased**
 - **Simplifies Program Development**
 - **Eliminates Error**
 - **Simplifies Program Changes and Maintenance**
 - **Increased Feasibility of Utilizing Higher Level Languages**
 - **Memory Requirements Lessened**
 - **Disadvantages:**
 - **Increased Hardware Costs**
 - **Increased Computational Time Requirements**
 - **Software Floating Point**
 - **Hardware Floating Point**
- Hardware Floating Point Application Selected;*

The study attempted to identify those items which could impact the development cycle and which would tend to act as high cost drivers. These items were culled from the experience gained from Apollo by Grumman/Boeing and its associates and from the Grumman experience on the F-14A, E-2C and A-6E Projects.

Both the number of delivered software articles and the number of software impacting hardware configuration changes directly bear on the software development costs. Every major change to an established software article precipitates a complete testing and verification cycle for the system software.

A significant cost driver is "Man-Rating vs Interim Operational Capability" and deals with the introduction of the astronaut into the onboard processing loop. This cost driver refers to changes to the program to satisfy unique operating mode requested changes, rather than to changes that modify or expand the software computational functions. To offset the effects of this cost driver, it is recommended that the man-machine interfaces be defined early in the program and be treated with the same rigidity as any other interface.

The remaining cost drivers are summarized on the chart and are self-explanatory.

HIGH COST DRIVERS—SOFTWARE

- **Number of Delivered Software Articles**
- **Number of Hardware Configuration Changes**
- **Orderly Development/Avoid Saturation, Peak Loading**
- **Man Rating vs Interim Operational Capability**
- **Adequacy of Computer Size, Speed**
- **Adequacy of Support Software**
- **Failure Detection/Switchover/Configuration Management**

Software development by its very nature provides risks because its delivered form is a unique end-item. This fact is particularly true of Shuttle avionics software since no directly related effort (even Apollo) provides applicable off-the-shelf software. Individual hardware elements may each be truly shelf items; however, their combination interfaced to a computer causes a unique configuration for software implementation. The chart indicates some of the more significant risks in avionics software since they are dependent upon early decisions in the development cycle.

- **Computer Speed/Size** - The selection of the flight and ground computers of necessity must be made early in the program. It is, therefore, important to base these selections upon carefully derived processing estimates in order to avoid redesign of software or the more serious repercussions of larger, faster processing capability. The risk associated with under-sizing memory and speed is one of increased costs and program delays caused by major redesign activities

- **Hardware Incompatibility** - The mix of equipments required for onboard functions introduces hardware/software compatibility problems. Interface design and the coordination of the proper interchange between hardware systems, computing hardware, and executable software represents an important development risk. The Integrated Avionics Test Laboratory (IATL) and its ability to exercise all subsystems, and their interfaces with the flight software shall provide the means to minimize risk. An orderly and rigorous system checkout of all combinations of subsystem functions is required to establish hardware/software compatibility
- **Level of Autonomy** - The level of onboard autonomy required for checkout represents a significant development risk. The greater the amount of independent autonomy onboard compared to ground dependency, the greater the development risks. Criteria of crew safety and mission criticality must be rigorously applied to minimize this risk

SOFTWARE DEVELOPMENT RISKS

- **Speed/Size**

- **Level of Autonomy**
 - OBC
 - MCC

- **Software Reliability**

It should be recognized that this report does not conclude the software requirements effort for the Low-Cost Avionics. Many areas of additional activity have arisen as an outgrowth of this study. Some of the more pressing of these are outlined. The past experience of Apollo and of the other Grumman flight software efforts indicates that the software activities can never be started too early. The bulk of the high cost and risk drivers outlined in this report can be offset by proceeding with these software investigations now.

AREAS FOR FURTHER INVESTIGATION

- Selection of Flight Computers
- Definition of Simulation Facility Requirements
- Redundancy, Failure Recovery Implementation
- Definition of Data Interfaces Between Computers
- First Layout of Software for Flight Computers
- Define Software Configuration Management Plan
- Executive Structure
- Software Reliability
- Utilization of KSC Facilities for Flight Test

MAJOR ELEMENTS OF ORBITER DESIGN DEVELOPMENT TEST & EVALUATION PLAN

System Design	System Development	System Operations
Scientific Computing (Non-real Time)	Avionics Software Development Lab (FHF & FMOF Mk I, Mk II)	ASDL (FHF, FMOF, MKI, MKII)
System Simulation (Real Time) Dual Seat Motion Base	Full mission Simulation Lab (FHF & FMOF)	FMSL (FHF)
Breadboard Testing Electrical Hydraulic } Test Benchs	Flight Control/Hydraulic Test Lab (FHF) Integrated Avionics Test Lab (FMOF MkI, MkII)	FCHTL (FHF) IATL (FMOF, Mk I, Mk II)

LOW COST AVIONICS INTEGRATED DESIGN DEVELOPMENT TEST SCHEDULE

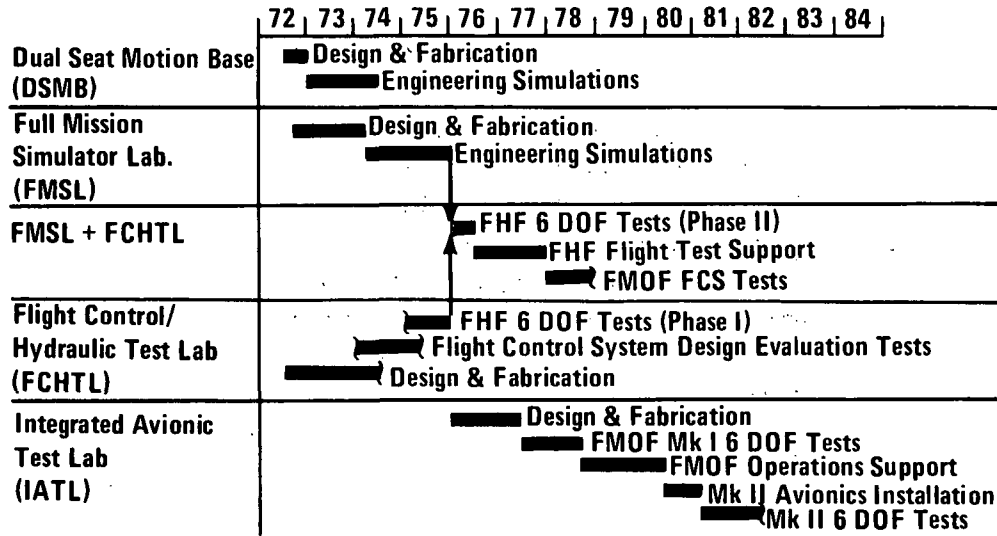

Software development is an iterative process of analysis design, verification and modification. This flow graph serves to indicate the ordered repetitive process of flight program software development. This repetitive process is necessary since the software represents a potential single-point failure during its development cycle, in an otherwise redundant system.

SOFTWARE DEVELOPMENT FLOW GRAPH

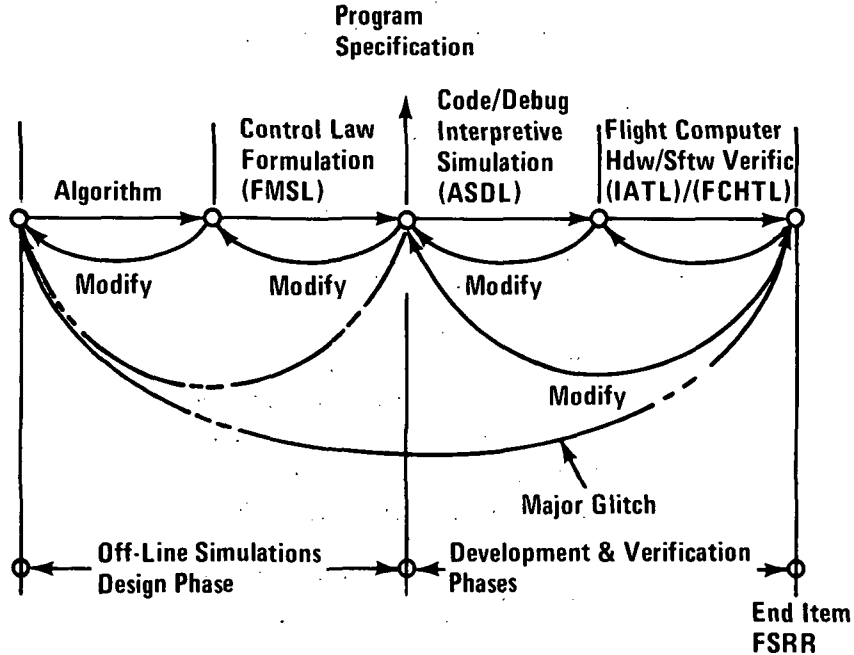

- Existing GAC facility
- 3 DOF motion capability, roll-pitch-heave
- 6 DOF virtual image displays
- 6 DOF all math model hybrid computing facility (GAC/NASA)
- 2 seat cabin mockup with functional controls and displays

TEST CAPABILITIES AND OBJECTIVES

- Full aero capabilities from 400K alt to touchdown
- conceptual design and design trade-offs
- Flying/handling qualities evaluation
- Displays and controls evaluation
- Flight control system design evaluation
- Guidance and navigation system design evaluation

DUAL SEAT MOTION BASE SIMULATOR

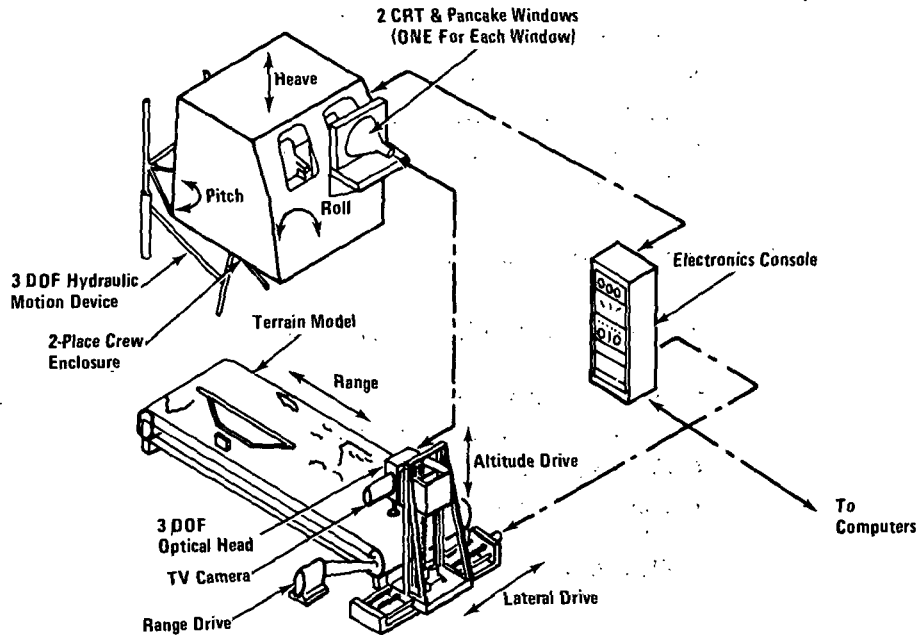

- Avionics - math modeled
- Non-avionics - math modeled
- Flight controls - math modeled
- Controls & displays - simulated/flight hardware

TEST CAPABILITIES AND OBJECTIVES

- Full mission, 6 DOF, man-in-the-loop simulations
- Design constraints and requirements
- FCS algorithm and formulation
- G&N algorithm and formulation
- Controls and displays formating and trade-offs
- Flying/handling qualities evaluation

FULL MISSION SIMULATION LABORATORY (FMSL)

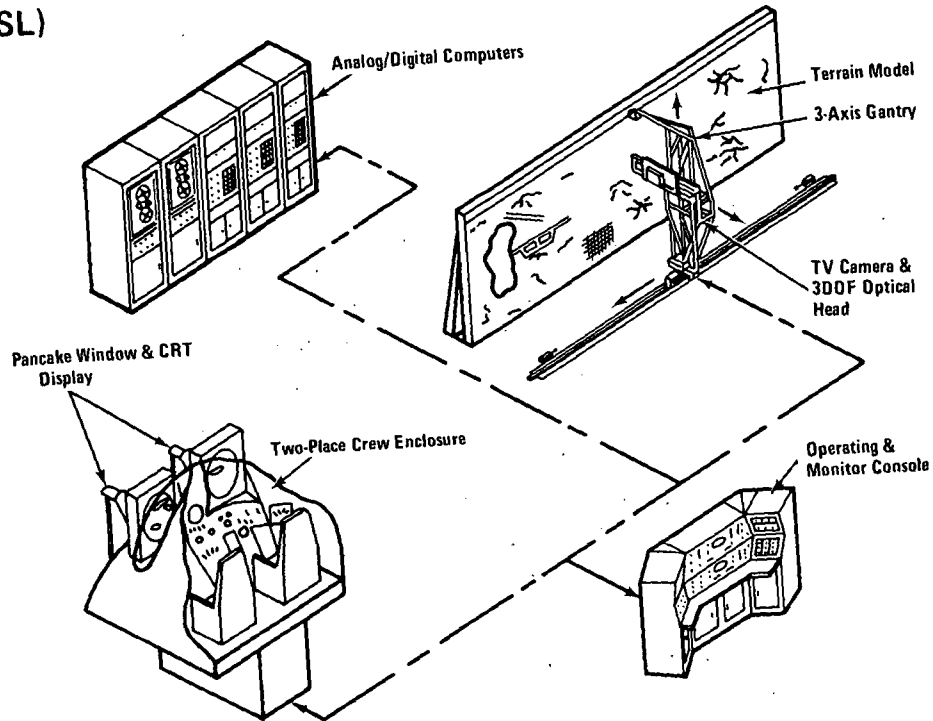

- Avionics - FHF flight set
- Non-avionics - math modeled
- Flight controls - flight set
- Controls & displays - *flight type/simulated*
- Dimensionally true structural mockup (aft 70 ft) of flight control surfaces, actuator hinge points, hydraulic distribution system and FHF avionics ships set with 6 DOF dynamics capability
- Phase I testing - Design evaluation testing of FCS. Subsystem avionics integration tests. Subsystem 6 DOF verification tests.
- Phase II testing - FCHTL & FMSL integrated for FHF combined subsystem hardware/software verification and mission performance certification.
- Flight test operations support - FHF flight test anomaly and engineering change proposal investigations

HYDRAULIC EQUIPMENT ARRANGEMENT ON FCHTL

Nose Gear Hydraulic Sys
Forshortened for Demand
Tests

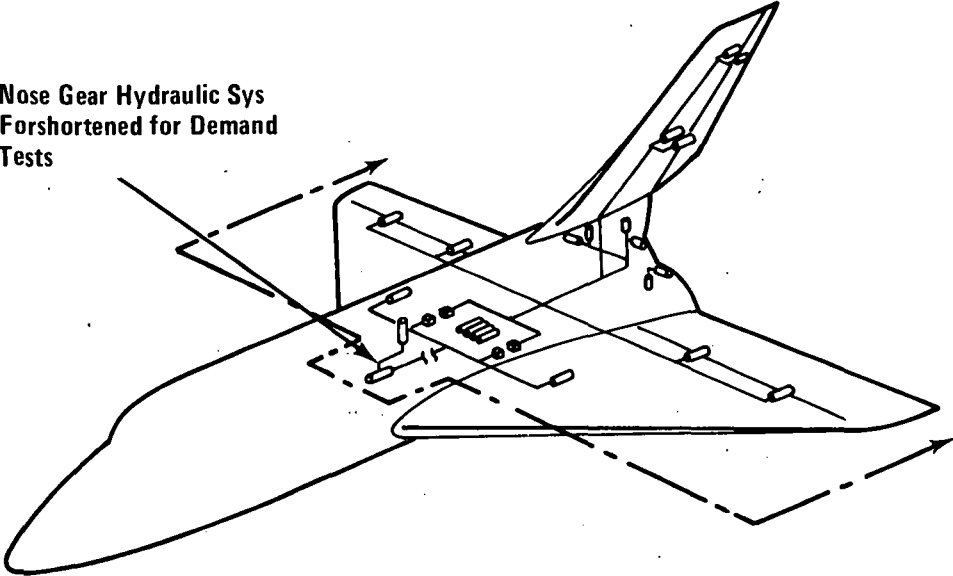

- Avionics - Mk & Mk II ships set
- Non-avionics - math model
- Flight controls - flight type/math model
- Controls & displays - Mk I & Mk II ships set

**TEST CAPABILITIES AND OBJECTIVES FOR FMOF
MK I & MK II**

- Hardware/software verification
- Malfunction and reconfiguration studies
- Avionics system hardware interface evaluation
- Avionics to Non-avionics system hardware interface evaluation
- Avionics system performance verification
- Mission performance verification
- Final crew training, max one week
- FMOF flight test operations support, real time and post-flight
- FMOF flight test anomaly and system modification evaluation

Operational

- Required for vehicle management
 - Operation (turn ON/OFF)
 - Redundancy selection (system level)
 - Caution/Warning surveillance
- 70% of operational measurements required to monitor and operate non-avionic subsystems

GSE C/O

- Required for pre/post-flight requirement to fault isolate to the lowest replaceable assembly
 - Additional data points are needed, over and above operational, to fault isolate beyond system level
- 62% of GSE c/o points required for avionics subsystems LRU fault isolation
 - Maximum potential for pre/post-flight checkout transfer to vehicle for Mk II (checkout autonomy) configuration in avionics subsystems

Dedicated DFI

- Dedicated development measurements are added to meet specific test objectives. Selected operational data points are used in conjunction with dedicated DFI for verification of vehicle system performance

Measurement sizing data contained in this document have been generated over the period of the low cost study and therefore minor differences in summation tables exist. Effort has been made to reference the baseline measurement list data on each table and to use the most current information available for sizing purposes.

Measurement list configuration control documents will be in effect for the orbiter/booster vehicles. A continuing effort of update and refinement will be expended in order to provide essential sizing information for the Data Acquisition Systems and to provide vehicle system configuration.

ORBITER/BOOSTER MEASUREMENT REQUIREMENTS

		Operational	Dedicated DFI	GSE C/O
FHF	Orbiter	334	700	≈730
	Booster	400	1056	≈800
Mk I	Orbiter	1050	967	1596
	Booster	650	1760	1350
Mk II	Orbiter	1060	389	1596
	Booster	650	200	1350

Phase B vs Low Cost Avionics – Comparitive Measurement Data

The Phase B measurement requirements were sized to fault isolate to the LRU for pre/post-flight checkout purposes.

The low cost avionics measurements derivation review resulted in a comparable total number of measurements required (2818 vs 2652) to accomplish the same level of fault isolation. Sequential studies were performed that identified the following operational measurements:

- Those required by the crew, in flight, to operate the vehicle systems
- Identified critical measurements to be monitored for system fault detection

- Provide the crew with sufficient data to enable system redundancy selection

A second phase of the investigation was initiated to identify measurements that are required, in conjunction with operational measurements, to fault isolate to an LRU for pre/post-flight checkout. To minimize the total number required, operational measurements were used as a baseline for system level fault detection and measurements added to fault isolate to an LRU.

A subsystem measurement comparison will evidence a considerable difference in total measurement numbers. In many cases, these differences are due to a basic design change in the measured subsystem (i.e., EPD).

LOW COST AVIONICS SYS, ORBITER MEASUREMENT COMPARISON (PHASE B vs LOW COST AVIONICS)

Subsystem	Phase B	Operational	GSE
Aux Mech Systems	(150)	30	—
Cryo & Prop. Tanks	12	24	62
Elect. Pwr Dist	695	39	39
Elect. Pwr Gen	164	76	39
Hydraulics	65	17	—
Turbo Jet Prop.	123	69	6
ECS/Life Support	167	46	—
Orbit Man. Prop.	236	28	68
Primary Prop.	277	68*	96
Attitude Control Prop.	253	109	332
Structure & Thermal Protection	89	18**	—
Crew Provision	24	—	—
Aero Surfaces	(75)	6	—
Payload	13	72	—
GN&C	102	61	170
Flight Controls	(210)	79	692
Telecommunications	163	48	84
Instrumentation	—	8	—
Data Management	—	2	47
*Primary Prop. Recorded Measurements	2383	800	1596
**TPS & Structural Recorded Measurements	(435)	(244) (12)	
Subtotal		1056	1596
Total	2818	2652	



ORBITER/BOOSTER VEHICLE CHECKOUT

ONBOARD CHECKOUT CAPABILITY

FHF

Onboard checkout functions consist of status monitoring to a vehicle function accomplished by programmed limit checking of data. This will be mechanized along the following lines:

- A large percentage of the avionic equipment present in the first horizontal flight vehicle is of recent commercial or military design, and incorporates some degree of built in test capability.
- Programmed limit checking provided by the data acquisition controller.
- The caution and warning display panel and dedicated displays provides crew and/or ground checkout personnel with status display

While in flight, the above capability will display system status, detect failures, isolate to a functional path, assist in redundancy management, and provide telemetry and recording of data. During ground checkout, the onboard capability will be used as an adjunct to the process of maintenance, repair, and preflight acceptance testing.

Mk I

At the time of the first manned orbital flight, onboard checkout will provide expanded status monitoring and fault isolation to include systems added for the orbital mission.

- Onboard fault isolation will be improved by the addition of more sophisticated techniques such as cross correlation of data from redundant subsystems and "time rate of change reasonableness tests

As orbital missions are extended and insufficient communications coverage creates a need for greater vehicle autonomy, ground based checkout functions will be added to the vehicle as needed. For ground checkout, the onboard capability will function as an adjunct to maintenance and acceptance testing.

Mk II

During the Mk II program, there will be a gradual transfer of checkout authority from the ground complex to the vehicle, accomplished on a subsystem by subsystem basis. The vehicle will evolve towards semi-autonomous checkout, with the evolution based upon flight, operational and ground test experience gained in earlier program phases.

In the Mk II configuration, the GSE data acquisition controller formerly part of the GSE, will become part of the vehicle data acquisition system. This change, along with increased computer capability, will permit increased onboard isolation to the equipment replaceable assembly. Additionally it will provide automation of checklists, and command initiated self-test during flight.

ORBITER/BOOSTER VEHICLE CHECKOUT (Cont.)

GROUND BASED CHECKOUT EQUIPMENT

FHF

Ground checkout equipment will be required for two functions:

- As a supplement to the onboard determination of system "Go/No-Go" status, permitting a greater depth of test
- To provide fault isolation to an equipment replaceable assembly, since the onboard checkout will usually isolate only to a functional path, and built-in-test in individual equipments will not isolate to black box in all cases
- Onboard non-redundant GSE RAU's and a ground based data acquisition controller will acquire and condition GSE measurements required for fault isolation to the equipment replaceable assembly.

Mk I

The ground checkout complex will perform a semi-automated checkout of the vehicle, and in the event of a malfunction will fault isolate to the equipment replaceable assembly. As orbital flight experience permits, ground based checkout functions will be gradually transferred to the vehicle, and more autonomous vehicle functions will be progressively proved out.

Mk II

The ground checkout equipment will continue to function as a tool in the maintenance and preflight checkout of the vehicle providing:

- A greater depth of test than the onboard function, to assure isolation to the replaceable assembly in cases where the OBC or BIT are limited
- Testing of the vehicle and its systems by exercising them in an "end-to-end" manner
- Trending analyses of vehicle systems
- Control of service equipment and other GSE

Dedicated/Integrated Instrumentation

Dedicated DFI

Accommodates low (PCM) and high (FM) frequency data requirement.

- Advantages

- Qualification, procurement, installation and data reduction independent of operational programs
- Maximum flexibility to respond to various requirements as identified
- Generally lower black box costs per measurement channel.

- Disadvantages

- Normal implementation techniques impose weight/penetration penalties for electrical harness
- No operational application for development equipment after flight test program completion

Integrated DFI/DFI

Accommodates operational requirements, (display, caution and warning, TM), low frequency DFI and high frequency data (FM).

- Advantages

- Optimized (weight and data handling techniques) to recover both operational measurements and development data.

- Disadvantages

- Type and data requirements (frequency) of DFI measurements preclude a practical integrated system being proposed that will be cost effective.
- FM data recovery is not required for the operational configuration and would represent a major portion of the integrated system.
- Necessary flexibility of development test program would impose an unwarranted impact on operational data recovery requirements.

Common Hardware (Recommended Concept)

Use operational hardware when possible to recover DFI data. High frequency DFI data (FM) is recovered with dedicated DFI equipment.

- Advantages

- Reduced program procurement and qualification costs
- Return to inventory as operational spares for further cost effectiveness
- Reduced impact of conventional DFI electrical harness weight and penetrations
- Maintains flexibility for modification in a development program

- Disadvantages

- Allocation of DFI measurements must be made within type and range limitations of operational equipment thus it may require some unique implementation for special data recovery requirements.

DEDICATED/INTEGRATED INSTRUMENTATION

DATA RECOVERY SYSTEMS

OPERATIONAL, DEVELOPMENT, AND GSE CHECKOUT
(MK I CONFIGURATION SHOWN)

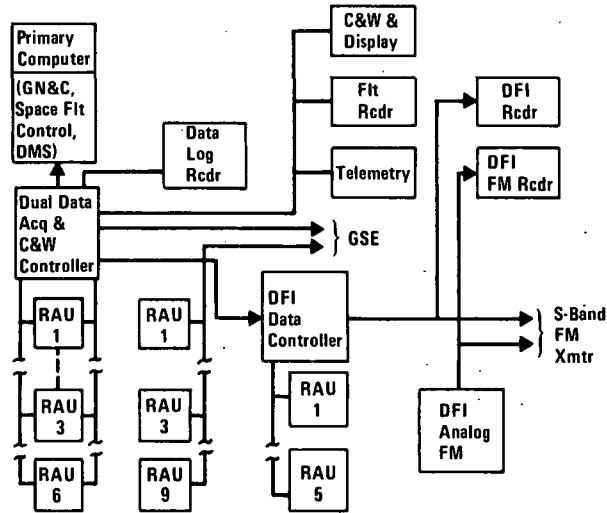

DEDICATED/INTEGRATED INSTRUMENTATION CONCLUSIONS

The evaluation of dedicated vs integrated instrumentation systems indicates that common data recovery system hardware used for operational and selected (low frequency) development requirements will be effective in simplification of procurement practices and implementation techniques thereby yielding on overall reduction in program costs.

Implementation of a common data recovery system (RAU) is extended to the GSE checkout require-

ments to resolve the immediate problem of GSE accessibility (i.e., numerous GSE cables to black box connectors) enhancing the total preparation cycle required for pre/post-flight checkout. Common GSE equipment will substantially reduce the integration impacts associated with transferring fault isolation to the lowest replaceable assembly requirement from ground dependence on Mk I to near autonomy in the Mk II configuration. Transferral will be an evolutionary process and minimal vehicle impact is expected due to the existence of compatible hardware installation.

MEASUREMENT REQUIREMENTS

The following tables break down measurements required for checkout of the low cost avionics orbiter. These are in two groups:

- Operational measurements required to determine that vehicle systems are functioning properly
- GSE measurements required to troubleshoot a malfunctioning system or systems, to permit isolation of a defective replaceable assembly

Within each group, measurements have been summarized by system into categories:

- Analog values to be measured
- Digital values
- Discrete events

Additionally, for each system, we have estimated the typical sampling rate, and the worst case (or maxi-

imum) sampling rate which will be required of the data acquisition hardware.

The measurements presented in these two tables were obtained by experienced spacecraft checkout personnel in consultation with cognizant Grumman design engineers for the various orbiter systems, and are of interest to the support effort for the following purposes:

- Overall measurement counts and their analog/digital/discrete subsets are indicative of the required capacity for the checkout system. Thus, in estimating the technical scope of our four alternate concepts, we have used these dimensions to "size" the ground checkout system
- Estimated sampling rates are indicative of the required bandwidth and general form for the data acquisition system and its corresponding checkout system interface



SHUTTLE OPERATIONAL MEASUREMENTS REQUIRE- MENTS (ORBITER VEHICLE) EXCLUDING GSE MEASUREMENTS

	Total Meas	Analog	Dig	Disc- rete	Telemetry	SPS Sampl'g Rate (Max)	SPS Sampl'g Rate (Typ.)
Auxiliary	30	3	0	27	30	1	1
Cryogenics & Propulsion Tankage	30	2	0	28	0	10	1
Electrical Power Distribution	38	24	0	14	0	10	1
Electrical Power Generation	98	51	0	47	0	1	1
Guidance, Navigation & Control	61	38	2	20	61	TBD	TBD
Hydraulics	17	13	0	4	17	100	1
Turbojet Propulsion	57	44	0	13	0	1	1
Data Management	27	24	3	0	27	100	100
Environ Control/Life Support	48	33	0	13	0	1	1
Navigation Aids	28	14	0	14	8	100	1
Primary Propulsion	*	0	0	0	0	-	-
Attitude Control Propulsion	312	168	0	144	0	100	10
Struct & Thermal Protection	104	58	0	46	0	1	1
Telecommunications	30	15	0	15	0	1	1
Crew Provisions	20	11	3	6	0	Clock	1
Display & Control	*	0	0	0	0	-	-
Instrumentation	*	0	0	0	0	-	-
Aero Surfaces	8	1	-	7	-	1	1
Flight Control	6	6	-	-	6	1	1
Payload Deployment & Retrieval	87	39	-	48	29	50	1
Orbit Maneuvering System	72	50	15	7	7	1	1
Total	**	1049	582	24	443	185	100/ 1
*Accounted for in Other Entries							

** Measurement Ref 1

SHUTTLE GSE MEASUREMENTS REQUIREMENTS (ORBITER VEHICLE) USED FOR SYSTEM FAULT ISOLATION

	Total Meas	Anal	Dig	Dis-crete	Tel-metry	SPS Sampl'g Rate (Max)	SPS Sampl'g Rate (Typ)
Auxiliary	*	0	0	0	0	-	-
Cryogenics & Propulsion Tankage	62	50	-	12	-	1	1
Electrical Power Distribution	39	39	0	0	0	1	1
Electrical Power Generation	*	0	0	0	0	-	-
Guidance, Navigation & Control	170	103	2	65	0	1	1
Hydraulics	*	0	0	0	0	-	-
Turbojet Propulsion	6	0	6	0	0	-	-
Data Management	47	2	15	20	0	Clock	Clock
Environ Control/Life Support	*	0	0	0	0	-	-
Navigation Aids	*	0	0	0	0	-	-
Primary Propulsion	96	96	0	0	0	1	1
Attitude Control Propulsion	416	416	0	0	0	1	1
Struct & Thermal Protection	-	-	-	-	-	-	-
Telecommunications	84	79	5	0	0	1	1
Crew Provisions	*	0	0	0	0	-	-
Display & Control	*	0	0	0	0	-	-
Instrumentation	*	0	0	0	0	1	1
Aero Surfaces	*	0	0	0	0	-	-
Flight Control	686	360	0	326	0	1	1
Payload Deployment & Retrieval	*	0	0	0	0	-	-
Orbit Manuevering System	64	64	0	0	0	1	1
Total	1670	1209	38	423	0	1 OR	1

***Accounted for In Other Entries

***Measurement List Ref 2.5 Oct 1971



This chart is intended to convey a conceptual understanding of the relationship between orbiter or booster systems, GSE, etc. The interface concept is that nearly all vehicle measurements will be transmitted to the checkout equipment in two PCM paths; one from the onboard Data Acquisition Controller, the other from the portable GSE Data Acquisition Controller. There will be uplink stimuli and certain atypical system measurements which will not be suitable for transmission in the PCM stream, so that tentative provisions have been made for about 100 hard wires.

In addition to the PCM and hard wire interface, the new equipment concept provides a receiver for acquisition of telemetered measurements, and also provides a playback unit to make information from the on-board recorder available to the checkout system. (This permits trend analysis, evaluation of vehicle systems which cannot be operated on the ground, diagnosis of "intermittant" problems, etc.)

The interface between the checkout system and mechanical, fluid, and gaseous/propellant support equipment is tentatively defined as the UTE standard digital interface mechanized by ground support inter-

face units (GSIU's) which are part of the UTE equipment. As the program develops, this tentative concept should be examined to see whether the service equipment should be so modified to adapt to the checkout equipment, or vice versa.

The major change in interface from Mk I to Mk II occurs when the GSE Data Acquisition Controller becomes part of the vehicle, and the onboard data management system becomes more autonomous. To the degree that this permits more onboard checkout, ground requirements decrease.

The most significant feature of the vehicle to ground interface as it is now visualized is that the number of connect points are minimized in the interest of expeditious checkout. If all of the required measurements had to be acquired by hard lines, there would be a lengthy connection process with inherent cable and connector reliability problems. It is difficult to imagine meeting peak flight schedules if the ground checkout system were to be burdened with these problems. By contrast, the present interface concept offers a rapid and reliable means for getting on and off the vehicle.

ORBITER/BOOSTER GROUND CHECKOUT INTERFACE (MK1)

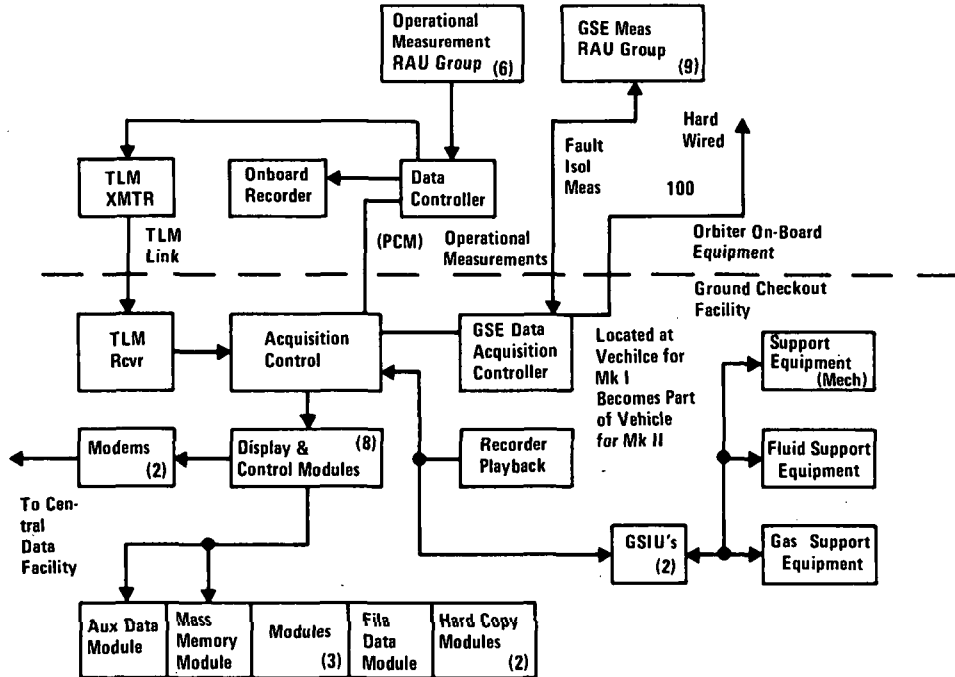

Comparison of the Phase B configuration with the low cost avionics configuration leads to the conclusion that a change to low cost avionics will not materially affect vehicle turn-around. Assuming that there are 30 available working days from recovery to launch, our preliminary analysis indicates that the avionic servicing will consume less than 6% of this time, so that other vehicle servicing requirements, notably those associated with engines and thermal protection system will continue to be of more significance.

The 6% value was arrived at as follows:

- From reliability analysis, the overall avionic failure rate is given as 12.439×10^6 per hour. For a 168 hour mission, we would therefore expect a mean of 2.08 failures at the time of recovery
- From experience, it is known that the rate of maintenance actions will exceed the rate of avionic system failure. This is true because:
 - It is normal for a certain number of non-defective avionic black boxes to be changed as part of the troubleshooting process

- Some avionic failures occur during the checkout process

(To account for the above factors, and also to allow for some degree of uncertainty in the reliability data, we have (conservatively) allowed a safety factor of ten between failure rate and maintenance action rate for purposes of this analysis. This leads to an estimate of 20.8 mean maintenance actions per mission.)

- We assume that each maintenance action will have an associated mean-time-to-restore of four hours, which includes verification of failure, fault isolation, removal, replacement, and verification tests to ensure that the associated problem has been corrected. This four hour value is consistent with aircraft avionic practice
- Assuming a series-parallel repair process such that 2/3 of the above maintenance actions occur in parallel and the remaining 1/3 are constrained to occur in series, we estimate a vehicle mean-time-to-restore of 27.8 hours, or 1.74 days, based on a two-shift operation. This is just under 6% of the available 30 days

UTE DEPLOYMENT SCHEDULE

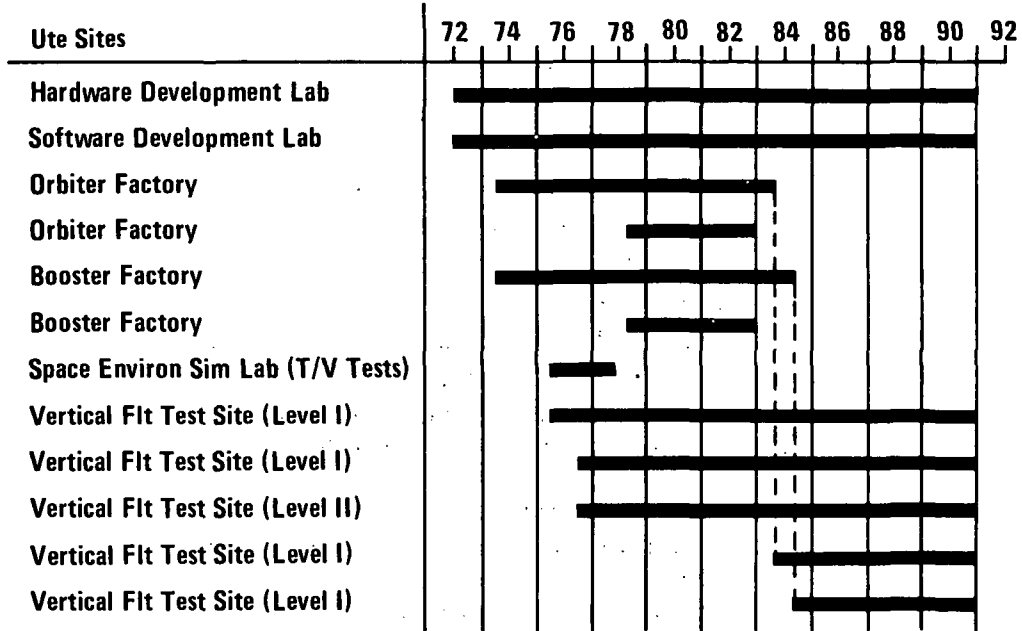

- **Development measurements**
 - Verify vehicle system performance
 - Not used for real-time safety-of-flight
- **Measurement source**
 - Selected OFI Transducers or OFI/CU interface
 - Dedicated DFI Transducers
 - Data Management system
- **Data recovery**
 - All DFI PCM and FM data on-board recorded
 - DFI PCM 100% telemetered
 - DFI FM 30% telemetered (most critical parameters)-cockpit selection of transmitted data
- **General philosophy**
 - Share RAU & CU basic design with oper. instru. and GSE
 - Use F-14 FM system designs
 - DFI pre-flight C/O thru use of dedicated C/O carts

FLIGHT TEST INSTRUMENTATION, DFI MEASUREMENT REQUIREMENTS

Configuration	Oper Meas Used for DFI	Dedicated DFI Measmts	Total DFI, Measmts	No. of DFI Measurements:		No. of DFI Measurements Required For:			
				Recorded On-Board	Tele-metered	Horiz Flt	Vertical Flt		
							Boost/Ascent	Orbit	Entry
Mk (FHF) (Orbiter No. 1)	216	700	916	424*	424	916	N/A	N/A	N/A
Mk I (Orbiter No. 2)	898	967	1865**	1865	558	606	1477	828	1331
Mk II (Orbiter No. 3)	501	389	890**	890	172	142	760	246	510

* Worst-Case Single Mission Requirement

** Total DFI Measurement Requirement; Final System To Be Sized By:

1. Signal Patching or Reprogramming
2. Total System Recording, Data Reduction Strip-Out

- Transducers/sensors for DFI utilization
 - Utilize commercial equipment off-the-shelf for the horizontal flight articles unique requirements; i.e., same approach used for military aircraft test programs
 - Utilize oper instru transducer designs for dedicated DFI measurements, when feasible to affect hardware commonality/lower procurement cost (fewer buys)
 - Trade measurement requirements vs commonality to reduce transducer types and ranges
 - Normalized output of DFI dedicated low-level transducers by category/type to simplify system calibration
 - Redundant transducers are installed only for measurements in non-accessible locations
- Data acquisition system (PCM)
 - Data from dedicated DFI or OFI transducers is conditioned and acquired by standard RAU design
 - DFI transducers not compatible with standard RAU are pre-conditioned by dedicated signal conditioning (15-20%)
 - Operational data required for DFI merge is obtained via OFI/CU – DFI/CU digital interface
 - DFI CU outputs a parallel PCM stream for on-board recording (1" dig. tape @ 30 min. record time) and a serial PCM stream for telemetering
 - Data channel scan sequence, gain and rate are controlled by the CU which allows a flexible system capable of expansion
- Data acquisition system (FM)
 - Operational data required for recording will be conditioned by DFI due to bandwidth requirements
 - Standard IRIG proportional bandwidth & constant bandwidth VOC's will be utilized. (13 tape tracks, 1" tape, track bandwidth 500KHz)
 - When required, one tape track will be used for wideband data (acoustic)
- Telemetry
 - The system will merge the serial PCM stream with one FM multiplex via pre mod mixer A; FM on the baseband & PCM on a sub carrier.
 - The second pre-mod mixer (B) will combine two additional FM multiplex
 - Each composite signal will deviate an S-band solid state transmitter. The transmitters will be combined by a diplexer and the resultant signal will be transmitted
 - A demodulator will be required on the ground to strip out each data stream
 - Any three FM multiplexers may be selected before or during flight.
- Time code system
 - Standard IRIG-B time code format
 - Modulated IKC for FM recording - SLO code also available
 - BCD digital time is supplied to CU for DFI time on PCM recording and TM
 - Time code will be synced with vehicle time
- Calibration sequencer
 - All data channels will contain either a voltage substitution or series/shunt RC stimulus
 - Activation of stimulus may be accomplished by either cockpit control or during check-out by the dedicated check-out cart.

DFI SYSTEM BLOCK DIAGRAM

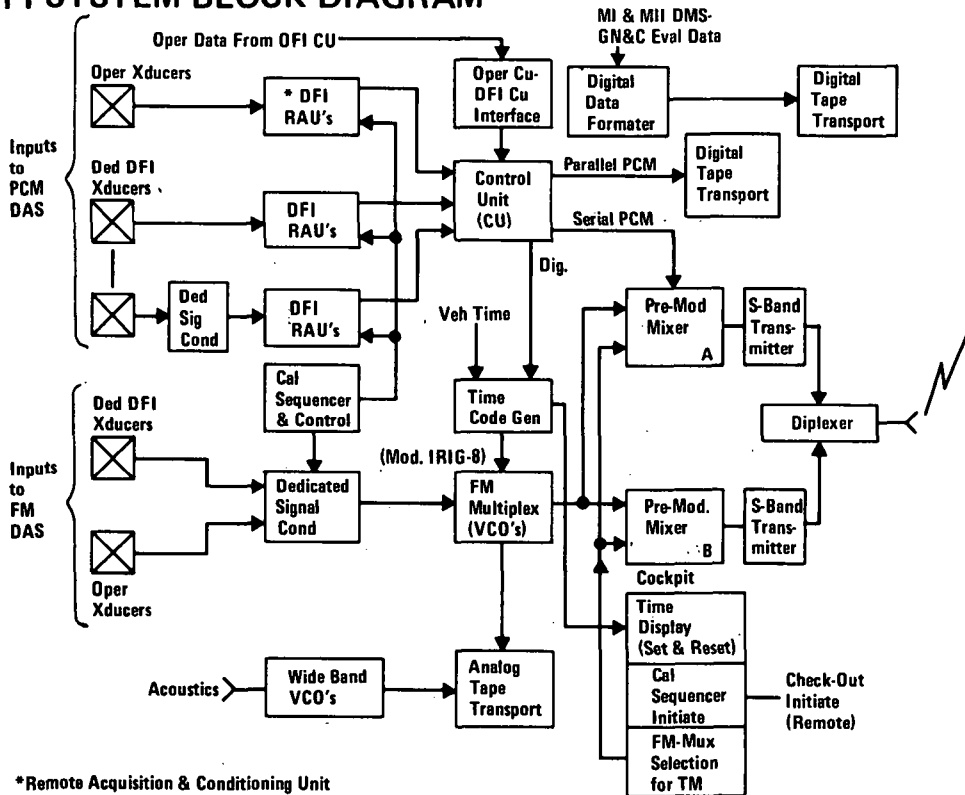

- **Dedicated DFI check-out carts**
 - **Modify design of existing check-out carts used presently for F-14 test A/C**
 - **Transportable carts permit system C/O & validation at sub-assembly and assembly facilities as well as launch site**
 - **Carts truly transportable - approximately 10' x 2.5' x 6.5'**
 - **Dedicated C/O carts permit DFI system C/O independant of operational C/O**
 - **C/O cart contains commercial off-the-shelf hardware**
 - **C/O via hardline or RF transmission**

CHECK-OUT CART BLOCK DIAGRAM

Flight Test Instrumentation, DFI

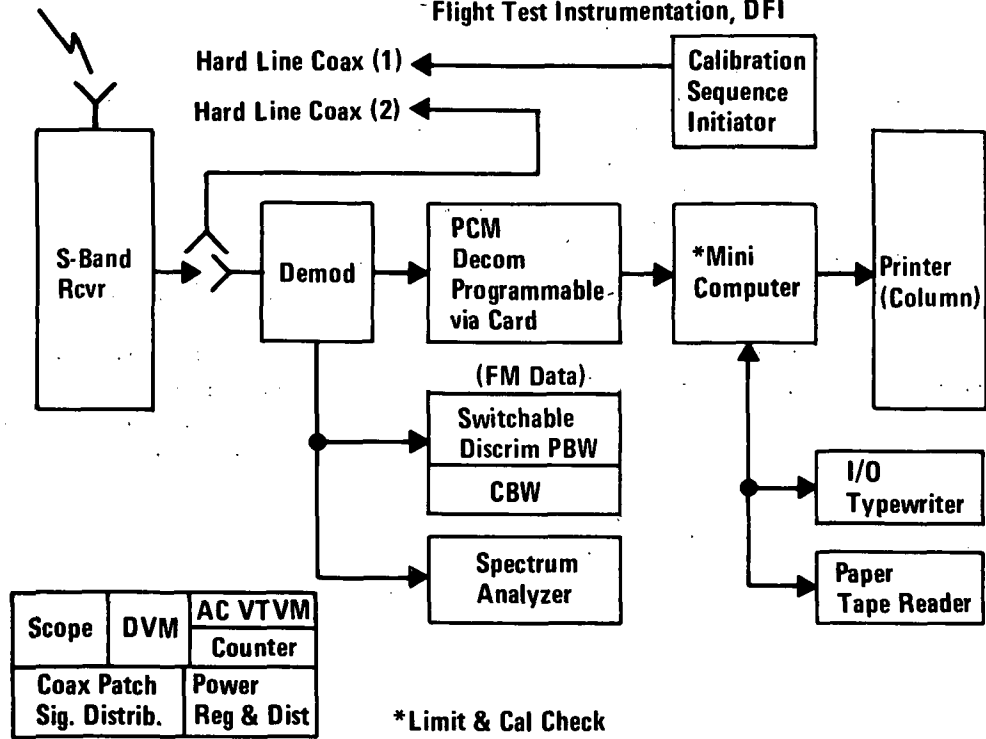

Operational Flight Instrumentation provides measurement of parameters for status and performance monitoring during various mission phases. Measurement of these parameters provide the on-board capability to detect and isolate failures necessary to implement automatic and manual reconfiguration and to confirm that reconfiguration has been implemented.

Operational measurements are required to support the orbiter vehicle management during the following various flight phases:

- FHF-334 measurements to support the operational aircraft flight systems for safe operation of the vehicle during the flight test program

- Mk I-1051 measurements to support the space and aircraft systems for:
 - Vehicle management
 - Caution/Warning
 - Redundancy management
- Mk II-1056 measurements to support the space and aircraft systems. Only minor changes to measurement requirements due to systems changes

ORBITER OPERATIONAL MEASUREMENTS

Subsystem	FHF	Mk I	Mk II
Aux Mech Systems	30	30	30
Cryo & Prop. Tanks	-	24	24
Elect Pwr Dist	24	39	39
Elect, Pwr Gen	23	76	76
Hydraulics	17	17	17
Turbo Jet Prop.	69	69	69
ECS/Life Support	14	46	46
Orbit Man. Prop.	-	28	28
Primary Prop.	-	68*	68*
Attitude Control Prop.	-	109	109
Structure & Thermal Protection	-	18**	18**
Crew Provision	-	-	-
Aero Surfaces	6	6	6
Payload	-	72	72
GN&C	61	61	61
Flight Controls	79	79	79
Telecommunications	6	44	48
Instrumentation	4	8	8
Data Management	1	1	2
*Primary Prop. Recorded Measurements	334	795	800
**TPS & Structural Recorded Measurements	-	244	244
Total	334	1051	1056



Equipment: Transducers/Sensors, Dedicated Signal Conditions. *Flight Recorders and Remote Acquisition Units (RAU)*

Transducer/Sensors

- Environmentally compatible with installation location
 - Benign environmental sensor installation requirements will be implemented with off-the-shelf spare qualified or delta qualified commercial transducer sensors
 - Unique implementation problem areas
 - Special Design will be required for the following measurements due to environmental factors: Quantity gaging Cryogenics consumables and discrete switches and fire detection sensors

Integral RAU Signal Conditioning

- Accepts "standard" measurements in a raw data format and converts directly to a serial digital word for further data processing
- Wide range of standard sensor interface inputs (resistance thermometer, strain gage, thermocouples, rpm, synchro/phase shift LUDT, parallel digital words and preconditioned 0 to 5 vdc)

Dedicated Signal Conditioning

- Provide normalization for unique measurements that are unacceptable to the RAU input requirements
- Normalize data for cockpit display requirements
 - Quantity (capacitance, rf, or pressure)
 - Volume/temperature (LOH)
 - Angular velocity (wide range rpm)
- Design Requirements
 - Unique electrical input/output matching
 - Unique packaging (Hostile environments)

Data Recorders (3 Types)

- Flight Recorder (ARINC 573 Data)
 - 4 voice channels, locator beacon, data
 - Mod comm/mil unit
- Maintenance Recorder (Boost and re-entry data)
 - Main Propulsion Data During Boost and Thermal Protection environmental history
 - Space Qualified
- Telemetry Recorder (data log)
 - Telemetry Compression
 - Space Qualified

OPERATIONAL INSTRUMENTATION SUBSYSTEM MK I/MK II

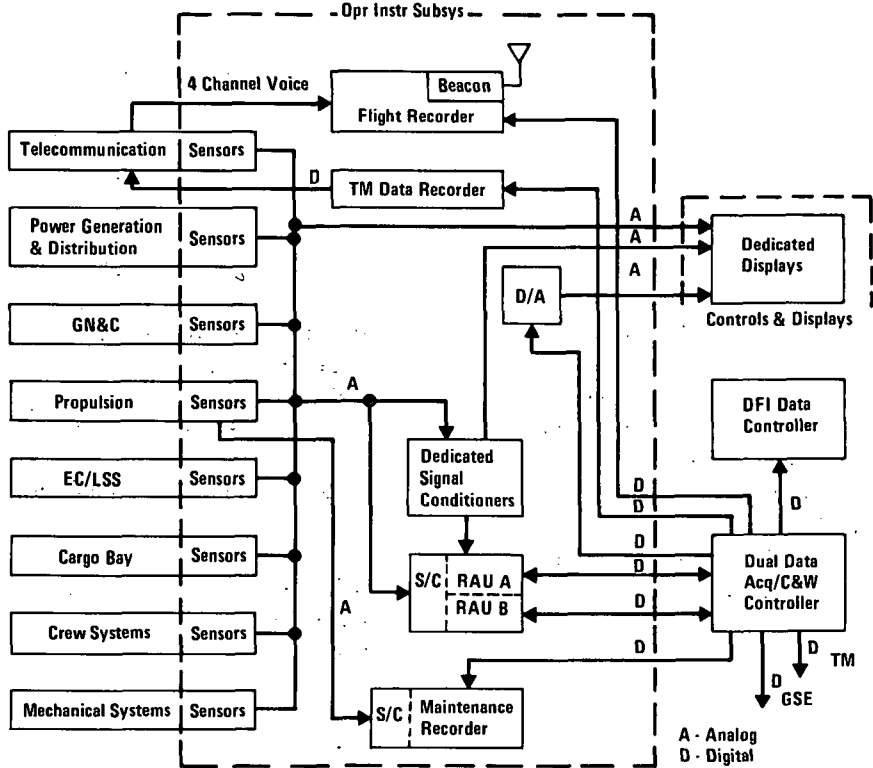

Sensor/Signal Redundancy Philosophy

Critical functions will be implemented to assure that at least two isolated data recovery paths exist to define the subsystem function status. Functional status will be acquired using one or both of the following techniques:

- **Simple Redundancy** – Two sensors implemented at the same point in the system to recover the same data, i.e., two pressures, two temperatures, etc. This method will be used in cases where the second technique, Functionally Related Measurements, is inadequate to provide basic redundant data
- **Functionally Related Measurements** – Different types of measurements, pressure, quantity, temperature, that are functionally

related and can be used to deduce system status in the event any single measurement channel fails – (i.e., quantity of gas and P/T using Boyles law)

Sensed information for critical measurements will be processed through separate data channels and presented to the crew as two separate pieces of information. For example, a discrete piece of data is displayed to the crew via a caution and warning light which can be verified through a related measurement via a dedicated display.

Redundancy for Ease of Maintenance

In cases of severe impact concerning accessibility, redundancy will be implemented if cost/weight effectiveness can be demonstrated for specific measurements.

LOW COST AVIONICS INSTRUMENTATION

Functionally Related Measurement

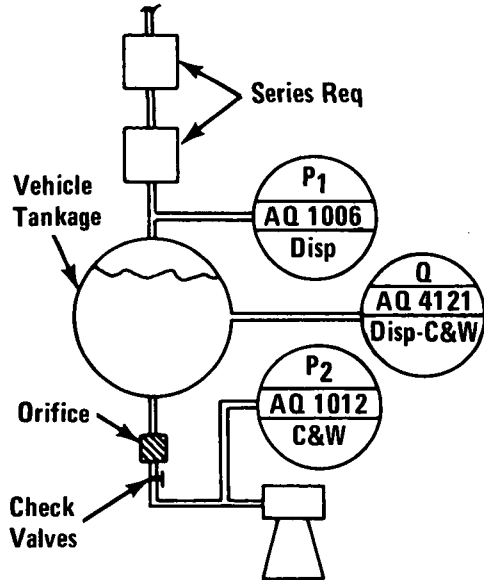

Subsystem Status = Predicted Valve +
Q₁ or P₂ (Known Differences)

OFI

Simple Redundancy

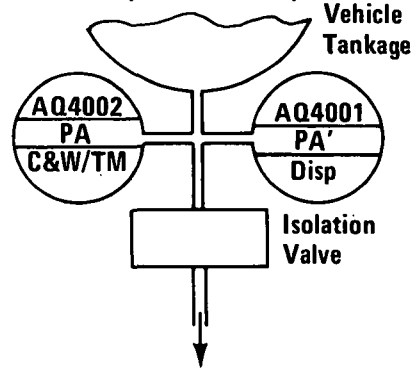

Subsystem Status = Predicted Valve +
PA and/or PA'

RISK ANALYSIS

Life cycle cost estimates for the candidate avionics system must be supplemented by cost impact on the shuttle program due to added weight, etc. Estimating uncertainty and cost risk must be evaluated to make an effective decision.

COST RELATIONSHIPS

- **Complex & Esoteric Techniques Not Possible Within Time Constraints**
- **Utilized Engrg Estimates for Life Cycle Cost Categories as Supplied by Grumman Team Members**
- **Utilized Guideline CER's for Impact Cost Determination**

Example:

Cost of Abort = Cost of Mission

In addition to avionics system life cycle costs, the shuttle program costs are also increased due to the impact of avionic system characteristics on shuttle design and expenditures.

IMPACT COST AREAS

- **Weight Penalty Costs to Orbiter & to Booster**
- **Cost of Mission Abort Attributable to Avionics System Failures**
- **Cost of Launch Delays Attributable to Avionic System Failures**

Probability distributions for input cost and risk driving parameters serve to reflect estimating uncertainty by allowing for a range of estimated parameter values. Risk is reflected by distribution skewness and variance.

ANALYSIS FLOW

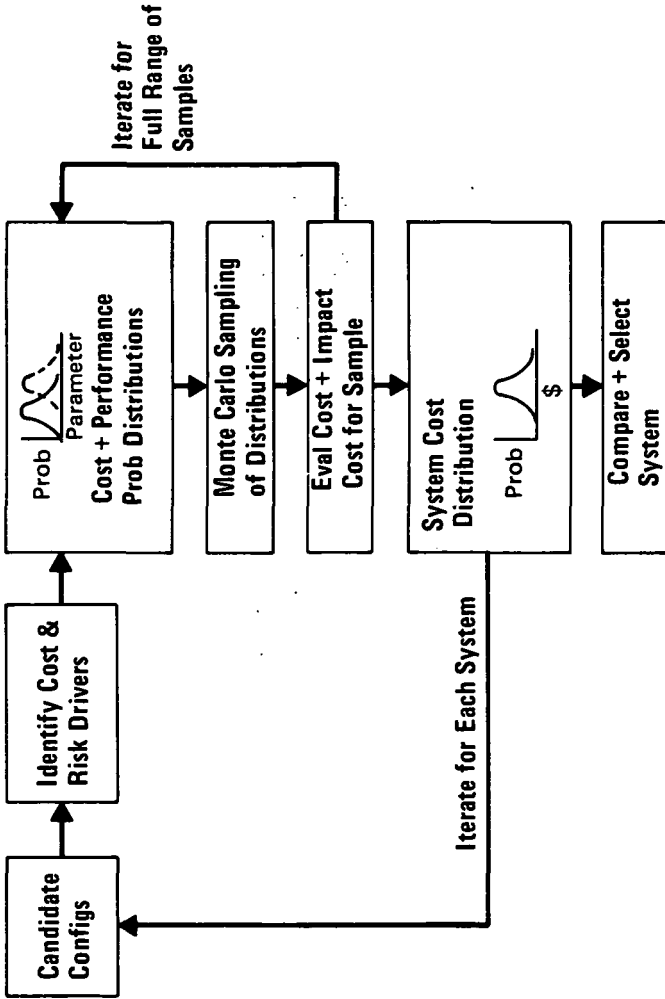

MONTE CARLO SELECTION PROCESS

Existing Computer Program Allows:

- **Development of Beta Distributions for Inputs**
- **Monte Carlo Sampling of Beta Distributions**
- **A Capability for Repetitive Sampling of the Alternative System Input Distributions**

The result of our study is a comprehensive computerized technique which supplies point estimates of cost and probability distribution reflecting risk and uncertainty.

RESULTING COST DISTRIBUTIONS FOR CANDIDATE AVIONICS SYSTEMS

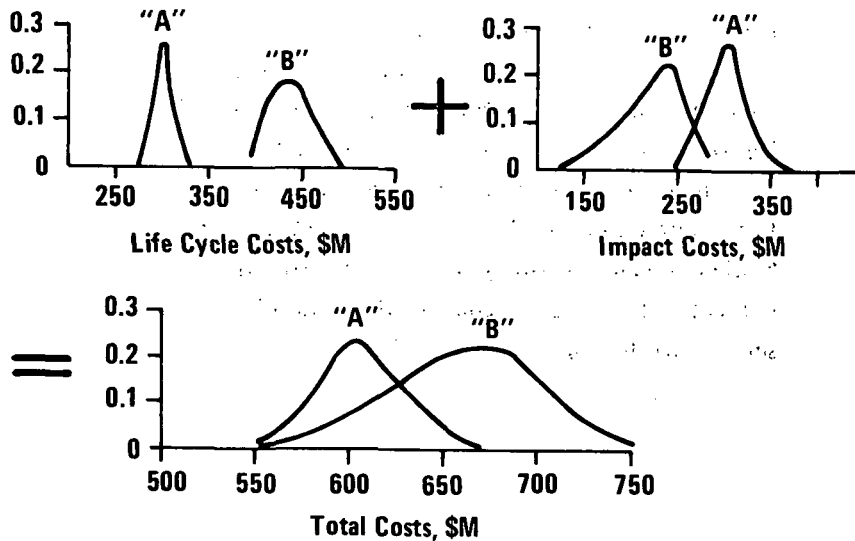

The magnitude of the resulting costs can be more accurately determined as input parameter values are improved. However, relative measures of risk are apparent from the current results. "Spaced proven hardware" is clearly less risky than the proposed centralized configuration, as can be seen in its relatively narrow cost spread and variance. The Grumman baseline system successfully combines the best attributes of both to achieve a configuration with risk as small as that for "space proven hardware."

RISK ANALYSIS SUMMARY

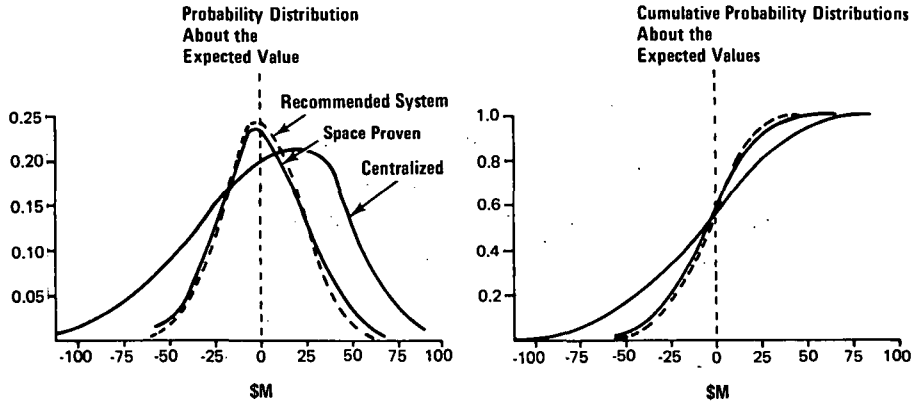

Similar risk analyses should also be applied to computer subsystems. Utilizing this risk analysis technique will allow selection of a low-cost subsystem with a hardware/software mix which minimizes cost risk.

APPLICATION OF RISK ANALYSIS TO ORBITER COMPUTER SUBSYSTEM

- **Identify Candidate Configurations (Federated vs Integrated)**
- **Determine Pertinent Impact Cost Parameters for Computer Subsystem**
 - **Weight, Power Reqmt, Reliability (Mission Abort/Delay), etc.**
- **Collect Data for Life Cycle Cost & Impact Cost Parameters With:**
 - **High, Low, & Mode Reflecting Cost Estimating Uncertainty**
 - **Beta Distribution Skewness & Variance Reflecting Risk**
- **Exercise Computerized Risk Analysis Model Resulting in Cost-Probability Distributions for Candidate Computer Subsystems, Allowing Selection of Candidate with the Associated Hardware/Software Mix which Minimizes Cost Risk**

Identification and collection of input parameter distributions for the computer subsystem hardware and software and the application of our Monte Carlo risk and uncertainty model to this problem will allow for a quantitative measure of computer subsystem risk.

COMPUTER SUBSYSTEM LIFE CYCLE COST DISTRIBUTIONS *

— Federated
- - - Integrated

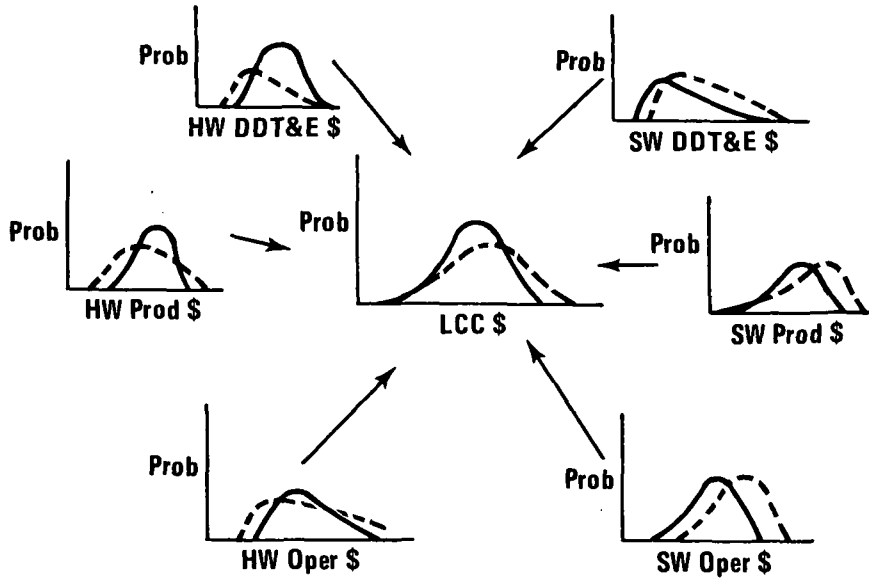

*Similar Curves for Impact Costs

Ground rules describing major schedule milestones are derived from NASA documentation.

The assumption regarding support of first horizontal flight by Contractor personnel is based upon a combination of experience on other programs and the maintenance concept associated with first horizontal flight.

Flight schedules are in accordance with Tech-

nical Directive GAC 4.

The assumptions that all launches will be from one site and that maintenance operations at that site will be conducted on a two-shift basis are based upon considerations of minimum support hardware adequate to the maintenance workload implied by the flight schedule. Similarly, the assumption that Level II maintenance will be conducted at the launch site was made to minimize logistic problems which would result from remote Level II maintenance.

GROUND RULES AND ASSUMPTIONS

- **First Horizontal Flight Supported by Contractor Personnel**
- **First Horizontal Flight Program – June 76 Through Jan 78**
- **Mk I Program – Sept 78 to Sept 89**
- **Mk II Program – Sept 83 to Dec 91**
- **Level II Maintenance Conducted at Operating Site**
- **All Launches (Mk I and Mk II) From One Site**
- **Flight Schedule in Accordance With Technical Directive GAC-4**



The use of existing DTE/FTE and commercial test equipment for support of first flight aircraft is a normal procedure on aircraft programs. Use of this concept for the Shuttle program would remove the GSE from a critical path leading to first flight and is considered desirable for that reason. Secondly, this concept is implemented at minimum expense. Thirdly, as the normal GSE becomes available, it can be phased into the program gradually with minimum difficulty of implementation, since the horizontal flight equipment remains available during the transition.

MAINTENANCE CONCEPT FOR FIRST HORIZONTAL FLIGHT

● Level I

- **Interim Line Test Sets and Procedures (Factory Test Equipment, Commercial Test Sets, Breakout Boxes)**
- **Mechanical Systems Maintained With Approved GSE**
- **Gradual Phase-In of Mk I Maintenance Concepts and Equipment**

● Level II:

- **Maximum Use of Existing Support Equipment and Factory Test Equipment**
- **Mechanical Systems Maintained With Approved GSE**
- **Gradual Phase-In of Mk I Maintenance Concepts and Equipment**

We have considered those possible combinations of GSE which are most likely to be implemented for the Shuttle program. Cost projections derived for each of the four competing GSE concepts are for the life of the Shuttle program and, essentially, contain all of the major life cycle cost elements which will be encountered over the projected 20-year program, with the exception of NASA costs for operating the support system. (NASA costs are considered later, by means of a relative estimate of labor required to operate each of the four conceptual systems.)

With respect to costs given in the accompany-

ing chart, the most significant findings are as follows:

- Minimum costs are obtained with new check-out equipment
- Maximum costs will be encountered if existing ACE equipment is used in the beginning of the program, followed later by the introduction of new equipment

To obtain a realistic evaluation of the four competing concepts, it is necessary to consider the relative values of NASA manhours required for the operation of each of the conceptual systems.

GSE CONCEPTS CONSIDERED

- Use ACE for Mk I Support, Followed by New Equipment for Mk II (Mk I Level II With Existing GSE) *Concept A* → \$510.4M
- Use New Equipment for Total Program (Mk I and Mk II, Level I and Level II) *Concept B* → \$458.7M
- Use ACE For Total Program at Level I, With Existing Test Equipment at Level II *Concept C* → \$466.9M
- Use ACE for Total Program at Level I, With Existing Test Equipment at Level II, But Modify the Method of Testing (Use ACE More Automatically) *Concept D* → \$494.8M

Note: The above projected costs are for contractor activities and do not include NASA costs for operating personnel.

Total estimated support costs were 458.7 million dollars, including Grumman, Boeing, and G. E. estimates for all equipment and services associated with a 20-year concurrent program.

If the Phase B estimate had been made on the same terms, and for a program of equal length, then a 394.6 million dollar estimate would have resulted. Comparing this Phase B normalized value with the low cost avionics estimate, the low cost vehicle configuration should lead to a support cost increase of 64.1 million dollars over the 20 years of program life. (An increase in support program costs would be expected to follow as a consequence of reduced on-board checkout in the vehicle, particularly in view of the fact that labor, not GSE acquisition cost, is the major driver of support life cycle cost.)

Some discussion of the normalization of Phase B support costs is in order at this time:

- In the Phase B estimate, it was assumed that checkout equipment would be government furnished. Thus, there were no ACE or new equipment costs in that estimate. To permit comparison between the Phase B and low cost study estimates, we must go back and normalize the Phase B estimate by adding the cost of new equipment
- Another normalization is required to convert the above resultant into a 20-year program cost. This was accomplished by adding 1986 through 1991 costs from the low cost study into the Phase B estimate to obtain the final normalized value

OVERALL SUPPORT IMPACT OF LOW COST AVIONICS

<u>Phase B Study (Normalized) Support Costs</u>	<u>Support Costs From Low Cost Avionic Study</u>	<u>Incremental Change</u>
\$394.6M	\$458.7M (For Concurrent Program)	+ \$64.1M

This chart is an explanation of the cost elements contained in the low cost avionics support cost estimate. All costs associated with the major ground checkout system (UTE) are treated as subcontractor costs and have been derived in detail in a separate cost package from General Electric.

Grumman costs presented are associated with development, manufacture, modification, etc., efforts relative to non-UTE support equipment. Additionally, Grumman costs are included for applications program

software required for testing of Orbiter systems, for publications, and for maintenance and support of ground equipment and facilities. (Note: Applications programs distinguish themselves from General Electric software costs, which are for preparation and maintenance of the checkout system compiler/executive.)

Boeing costs contained in this estimate are those which were estimated as required for Booster support and are of the same categories as those included for Grumman.

COST ELEMENTS

- **General Electric Cost Package**
 - ACE, ACE Modified, and New Equipment (UTE) Costs
 - Hardware and Software Development, Equipment Manufacture
 - Maintenance and Operating Costs Including Site Readiness
- **Grumman Costs**
 - Support Engineering Development and Sustaining Effort for GSE, DTE, FTE
 - Manufacture and/or Modification of GSE, DTE, and FTE - (Excluding ACE or New Equipment)
 - Software Development, Maintenance, and Control - Applications for Vehicle System Tests and Data Reduction)
 - Publications Costs, Including Operations Updating
 - Maintenance and Support of Ground Equipment and Facilities - (Operations Support)
- **Boeing Costs**
 - Same Categories as the Above Grumman Costs

The accompanying chart shows projections of NASA manhours required to staff each of the four alternative support systems over the life of the shuttle program. For a realistic tradeoff, the dollar costs of the preceding chart should be considered along with the "ownership costs" implied by operating manhours. From this frame of reference:

- Concept B is the most economical choice
- Concept D ranks second in desirability
- Concepts C and A are comparatively expensive

Projected operating manhours were developed by using the number of checkout stations, number of years of operation for each, a two-shift operation for each, and typical staffing levels appropriate to each of the four alternative concepts under consideration:

- For concept A, we used ACE staffing for manual checkout (as in concept C) followed by introduction of the new equipment, with a 60-man staff, later in the program
- For concept B, we estimated that a two-shift operation of new automatic checkout equipment would require only 60 men. This is a conservative estimate; depending upon operating philosophy, the actual system could require a smaller staff
- For concept C, we assumed that ACE stations would be used with an "Apollo" checkout philosophy, which would lead to a two-shift staff of 140 men
- For concept D, we estimated that a more automatic mode of operation for ACE would reduce the above staff by approximately 46%. From past studies of the Apollo checkout effort, we believe this is a conservation estimate of staff reduction

PROJECTED NASA OPERATING PERSONNEL

● **Concept A - 9.7M Manhours**

● **Concept B - 4.8M Manhours**

● **Concept C - 14.8M Manhours**

● **Concept D - 7.7M Manhours**



Concept A requires a transition from ACE to new checkout equipment at a time when Shuttle operations are intensive. This could present operational difficulties in getting the new system "on-line" without compromising vehicle turn-around or mission availability. At the same time, concept A is potentially the most expensive approach to Shuttle support. For these reasons, it was eliminated from the tradeoff.

Concept B is clearly the most economical approach, and does not suffer from the technical disadvantages of A or C. It was selected for use in the low cost avionics study.

Concept C assumes essentially manual operation of ACE, as in the Apollo program. In view of planned Shuttle mission schedules are implied vehicle turn-around-times, it is doubtful that manual testing is fast enough to suit the application. Again, from the cost frame of reference, concept C is expensive. We therefore eliminated concept C.

Concept D is slightly more expensive than B, but overcomes the transitional and test time disadvantages of A and C. Although it was not selected, we believe its merits further study, along with B, as a candidate for eventual implementation.

TRADEOFF

- **Concept B Is the Cheapest of the Alternatives, Both to Implement and to Operate**
- **Considering Implementation and Operating Costs, Concept D Is the Next Most Desirable**
- **Concepts A and C Are Both Relatively Expensive, by the Above Criteria**

Support Cost Distribution By Year For Concept B

This curve represents the probable yearly distribution of the 458.7 million dollars estimated for support of the low cost avionics configuration under concept B; it was developed on the basis of development, manufacture, and operation cost spreads extrapolated to include G.E., Grumman, and Boeing costs.

Support Cost Distribution By Year For Concept D

The next curve is a similar projection of concept D support costs by year.

Comparison

The smaller concept B life cycle costs peak in 1975-76 at approximately 38 million dollars per year. By comparison, concept D costs peak later, at approximately 41 million dollars per year.

Significantly, D takes about two years to reach its average funding level of about 25 million dollars per year. On the other hand, B reaches its average value of 23.5 million dollars per year in about ten months from go-ahead, giving it the appearance of a "crash program."

SUPPORT COST DISTRIBUTION BY YEAR

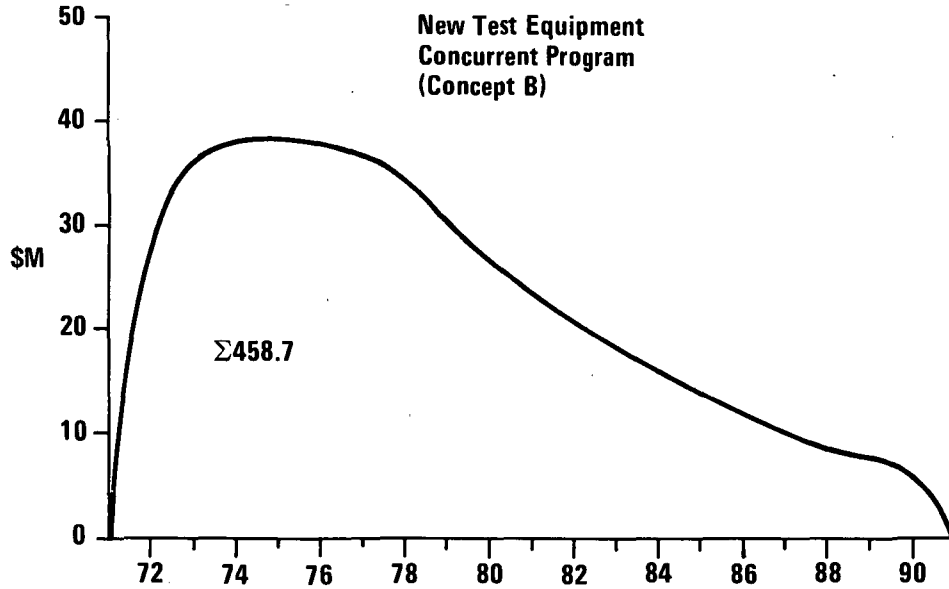

SUPPORT COST DISTRIBUTION BY YEAR

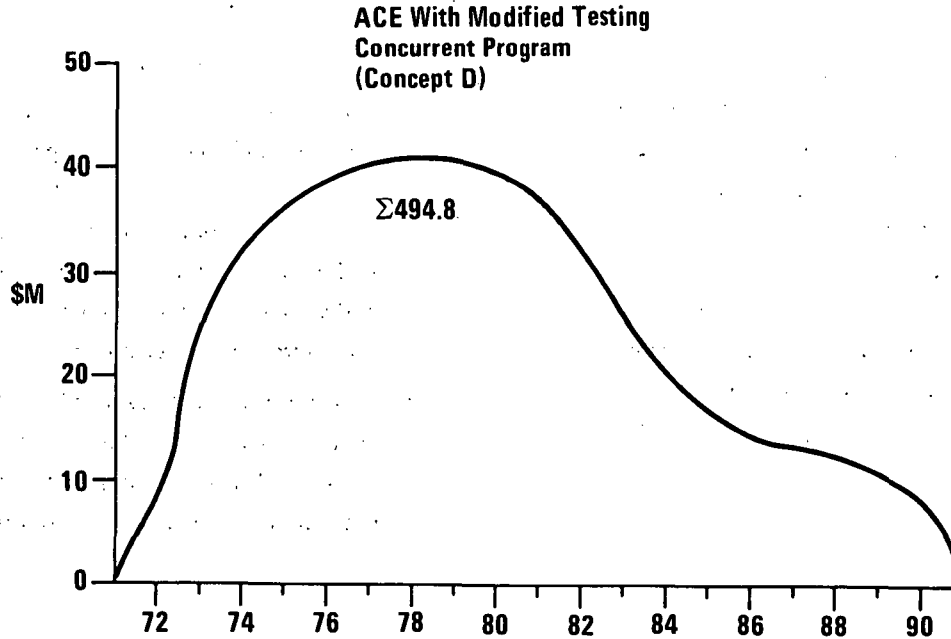

At this point, our best judgement is that the risks, life cycle costs, peak yearly costs, and staff levels implied by concepts B and D should be the subject of further study. As the program develops, concepts B and D should receive further consideration for a number of reasons:

- Technical risk was not closely evaluated. We assume that either ACE or new equipment could be developed in the available time

- With respect to ACE, it is not at all certain that equipment of 1963 design can be refurbished and maintained in operation economically in the 1985 to 1991 technology. If it should become necessary to replace ACE with something new at that late date in the program, there would be a substantial and unprogrammed cost increase
- This above tradeoff was based largely upon life cycle costs. As we will show later, concepts B and D show significantly different peak costs and yearly cost distributions

CONCLUSION

- **Concept B Appears Most Desirable, But Requires Further Study**
 - **Technical Risk?**
 - **Peak Yearly Costs?**

- **Concept D Merits Further Study**
 - **Could Have Lower Peak Costs and Less Technical Risk**
 - **Practicality of Using 1963 Equipment Beyond 1985?**

The ground data system associated with mission operations represents a significant cost factor in the shuttle avionics development. The low-cost avionics approach requires a reduction in the onboard data system capability. Four baseline configurations for a low-cost avionics system were evaluated to determine the degree of impact in program cost of accomplishing certain types of data processing and evaluation using the ground data system of the MSFN and MCC. The approaches evaluated in this process used 1) commercially available avionics equipment, 2) space and military avionics equipment, and 3) newly developed avionics equipment. A fourth configuration consisted of a recommended system which is a combination to produce the best low-cost approach to the problem solution.

STUDY OBJECTIVES

- **To Examine the Characteristics of Each Baseline System & Determine the Impact on the Ground Data System**
- **To Establish the Support & Differentials for Ground Data System Support of Each Avionics Package**

STUDY APPROACH

The approach used to develop the ground data system cost impact is given below.

Develop a Ground Data System Baseline

A ground data system exists which will be modified to support space shuttle. The Manned Spaceflight network and Mission Control Center can be accurately predicted for configuration for 1 January 1974 (SKYLAB completion). Factors such as an integrated network (MSFN plus STADAN), and a TDRS, DOD (SGLS), and a MCC terminal system and data base were also considered in the missions operations baseline.

Determine Common Evaluation Criteria

Evaluation criteria was established to insure that each configuration was weighted equally. Criteria was established using functions which are subject to a ground-onboard trade-off or which are currently being accomplished by ground data systems. Criteria was established in systems management, trajectory management, aeromedical management and mission management.

Establish Groundrules and Assumptions

The groundrules and assumptions were consistent with the baseline. Special groundrules for cost criteria included 1) Maintenance and operations cost of the

MSFN and MCC would not be charged to the shuttle; 2) engineering, hardware and software development and implementation associated with supporting the shuttle would be charged to the shuttle cost.

Major Cost Drivers

Technical areas were defined which would contribute significantly to cost impacts if implemented.

Develop Ground Data System Concept

Each configuration was evaluated and requirements developed. A ground data system concept was generated for each configuration from these requirements.

Determine Technical Impact for Each Configuration

The requirements and concepts were placed in matrix form and compared for hardware and software impacts: A delta for each configuration was established.

Provide Cost Comparison for Each Configuration

A baseline cost was established for engineering and software for the configurations.

Recommend a Level of Autonomy

A group of functions were evaluated to determine their impact on ground data system processing. Those which produced the largest ground system impact were recommended.

STUDY APPROACH

- **Develop Ground Data System Baseline**
- **Determine Common Evaluation Criteria**
- **Establish Ground Rules & Assumptions**
- **Develop Major Cost Drivers for Ground Data System**
- **Develop Ground Data System Concept for Each Configuration**
- **Determine Technical Impact on the Ground Data System Baseline for Each Configuration**
- **Provide Cost Comparison for Ground Data System Support of Each Configuration**
- **Recommend a Level of Autonomy for a Realistic Space Shuttle Program**

Tracking and Data Acquisition Systems Other Than Existing Systems

Unified S-band provides the primary tracking and data acquisition interface for the MSFN. While certain sites have other capabilities, deviation from the primary interface would result in upgrading each MSFN site to satisfy the requirement.

Polar Orbit Missions During Flight Qualification Testing Prior to TDRS

Launches from the ETR using expendable or recoverable boosters generate a complex launch program. The Mark I vehicle can be supported as required for nominal launch azimuths. Polar missions during the system development and test phase would increase the need for ground data system interface. Integration of the MSFN and STADAN will partially alleviate the problem of extended periods of limited contact. Use of the TDRS will eliminate the problem. If a high level of ground support is required for the Mark I Shuttle, the polar missions should be deferred until TDRS availability or less ground dependency must be designed into the vehicle. The alternative is to implement more sites in the network.

Noncompatible Shuttle Telemetry System

The ground data system has a flexible capability to interface vehicle data types using the reprogrammable decommutator. Should the limitations of these systems be exceeded in bit rate or format structure, then a significant impact would exist throughout the network. The baseline systems provided a compatible 51.2 KBPS data interface and an experimental (DFI) data link not exceeding the capability of the sites.

Use of a Command Technique Other Than Apollo

The command technique developed for Apollo has been proven through mission use. To introduce a different method of command between the ground and the vehicle would require the development and validation of the new technique at considerable program expense. The need for command capability (word length, etc.) beyond the current capability has not been identified.

Degree of Utilization of TDRS

The TDRS will become operational during Mark II. This system adds the flexibility of "any time access" to the ground data system. The consideration for use of ground data system for extensive processing functions becomes paramount. The TDRS can provide an integrated system but the degree of integration between vehicle and ground will have significant cost impacts.

Integration of DOD and NASA Acquisition Systems

Information was consolidated concerning the DOD and NASA systems. Inspection of these capabilities indicates that integration of these facilities into a common network would provide an additional cost to the program.

Transmission of Secure Data Through MSFN and Processing at MCC

The MSFN is not configured for handling secure data.

MAJOR COST DRIVERS

- **Non-Compatible Shuttle Telemetry System (Rate & Format)**
- **Tracking & Data Acquisition Systems Other Than Current & Planned**
- **Polar Orbit Missions During Flight Qualification Testing Prior to a TDRS**
- **Use of a Command System & Technique Other Than That Available Post Skylab**
- **Degree TDRS Utilization (When Operational)**
- **Integration of DOD & NASA Data Acquisition Systems**
- **Transmission of Secure Data Through MSFN & Processing at MCC**

In the analysis of the configurations for low cost avionics, it was found that the three major disciplines of telemetry, tracking, and command were required to support each configuration. The input parameter rate to the MSFN and MCC was 51.2 KBPS for operational telemetry and 500 KBPS for engineering (DFI) data. These rates did not exceed the capabilities of the remote site. The RF interface was unified S-band for all cases. In the evaluation of the hardware configuration, it was determined that the hardware capability of the MSFN and MCC on 1 January 1974 could support the space shuttle. No new procurements could be identified. Some modifications were required to provide an acceptable support configuration.

RESULTS OF PRELIMINARY SUPPORT ANALYSIS

- **Ground Data System Support Reqmts are Approximately the Same for Each of the Avionics Configurations Considered in This Low Cost Avionic Study**
- **The Post Skylab Ground Data System Will Have the Capability to Support any of the Avionics Configurations Considered**
- **No Major Hardware Procurements Could be Identified as Required for Ground Support of the Shuttle. Only Modifications to Existing Systems Were Required.**

The software associated with the MSFN remoted site, GSFC communications interface and the MCC were baselined at a functional level. The effect on the software was that of introducing a new vehicle, such as the ATM on SKYLAB, into the system. The telemetry processor at the remote site was capable of handling the 1050 parameters associated with operational telemetry. This number is somewhat larger than the CSM, but does not exceed the AM/ATM of SKYLAB.

The baseline telemetry processing was the same functionally with changes required for input formats, input sampling rates, scaling, changes, limit sense changes, event drivers, etc. The functional program was not altered.

Command processing was required for Shuttle computer loads associated with flight dynamics and real time commands associated with data retrieval. No new concepts would be identified. While program

changes will be required, a major software impact could not be defined. The SKYLAB command technique was adequate for the requirement. An increase in command requirement will exist for an unmanned vehicle but is within the capacity of the ground data system.

The trajectory processing will be impacted by an increase in launch complexity (launch azimuths from 0 to 90 degrees) and a conceivable dog-leg launch to polar orbit from ETR. A recoverable booster must be considered and a new sequence of abort modes with the orbiter and booster landing capability. The entry phase will present a new entry profile with precision trajectory management required. The baseline trajectory program will need to undergo extensive change to satisfy the requirements. The manned mission support requirements were compared with Apollo 8 and the unmanned requirements with AS503. The baselined ground data system could support the known requirements at the functional level.

RESULTS OF PRELIMINARY SUPPORT ANALYSIS (CONT)

- **No New Major Software Developments Could Be Identified. Modifications & Rework of Existing Programs Can Meet Reqmts**
- **The Level of Ground Data System Support Required for the Mk I Configuration Was Determined to be Approximately the Same Level as Earth Orbital Apollo Flight**
- **The Effect of an Unmanned Orbiter is not Considered to be a Major Cost Impact Except in the Area of Command. The Effect of Automatic Landing System Must be Examined**
- **The Major Cost Impacts Associated With the Ground Data System Will Result From Implementation to Meet the Support Reqmts for Mk I**

A phased approach was considered for each configuration. The growth profile for each avionics package was designed to meet only those requirements of the mission. A First Horizontal Flight (FHF), First Manned Orbital Flight (FMOF) or Mk I and a final configuration (Mk II) were evaluated. A ground data system transition from each configuration was developed. The degree of autonomy achieved by the configurations varied with the recommended configuration achieving an excellent compromise. The analysis of these transition profiles led to the conclusion that the Mk II orbiter will not require less ground support hardware, but rather will result in using less of the Mark I ground data system hardware and software capabilities. The Mk II ground data system requires the same ground support configuration except that a TDRS with any time access capability has been combined with the integrated MSFN/STADAN, and the MCC will have fully implemented terminal system and data base. These added capabilities to the ground data system add to its flexibility and make it attractive for use in accomplishing the non-system functions of the shuttle.

The Integrated Network and MCC will be multiple user systems. The impact of Mk II on the system will be similar to the transition from one Apollo vehicle to the next. Normal M&O of hardware and software should be adequate for the transition. A completely different Mk II would not exceed the cost impact of a Mk I.

The results of evaluating the various configurations indicated that the ground system was insensitive to the degree of autonomy of the vehicle. All the configurations reviewed established requirements for telemetry processing, trajectory support and command load and RTC support. A basic configuration of the ground system in hardware and software is required to provide support in these disciplines. The degree of mission time data use will provide the major reduction in ground data system cost unless one or more of the major disciplines is deleted. The cost differential between all configurations considered was minor, and the engineering and software of the ground system could not be used as a cost driver in selecting an avionics configuration.

RESULTS OF PRELIMINARY SUPPORT ANALYSIS (CONT)

- **Transition to Mk II Will be a Minimum Cost Impact on the Ground Since it Involves Primarily the Deletion of Ground Support Functions Provided for Mk I**
- **The Ground Data System Cost Differences Between the Avionics Configuration is Not an Influencing Factor in the Choice of Low Cost Avionics System Approach**
- **The Ground Data System Cost is Relatively Independent of Autonomy in the Phased System Approach**
- **The Shuttle Avionics Design, Regardless of the Cost Approach, Should be an Integrated Effort With Full Assessment & Consideration Given to the Capabilities of the Ground Data System & TDRS**

The ground data system was evaluated to a functional level to determine the degree of characteristics of a vehicle and its onboard processing functions which would have the most significant impact on the ground data system. The impact will be primarily in the user facilities of the processing and the required time frame for processing. The vehicle characteristics included as a minimum:

- Does not rely on ground data processing which involves real time processing in the decision making functions
 - Does not rely on the ground to process data associated with immediate vehicle, mission and payload deployment problems
 - There is a telemetry exchange between vehicle and ground. The vehicle format should be selectable by the ground or crew. (On-board compression should be examined as one method for transmission of normal operational transfer of telemetry)
 - The uplink to the vehicle involves the transfer of command loads and data access real time commands to the Primary computer
- Flight control programs are dedicated to vehicle systems and are refined programs which remains fixed
 - Data management programs have program flexibility and are used as the growth side of the system. As vehicle autonomy increases, the data management capability is increased with the growth profile established to accomplish the total real time processing of the vehicle (excluding payload) to manage the vehicle environment as the autonomy goal
 - The flight control and data management software address only the space shuttle and the control of its systems and its environment. All other processing functions are accomplished on the ground or by equipment charged to payload
 - The general ground support concept for such a vehicle provides a flexible data retrieval capability for both the flight crew and ground support personnel

GENERAL CONCEPT FOR MK II SHUTTLE GROUND DATA SYSTEM

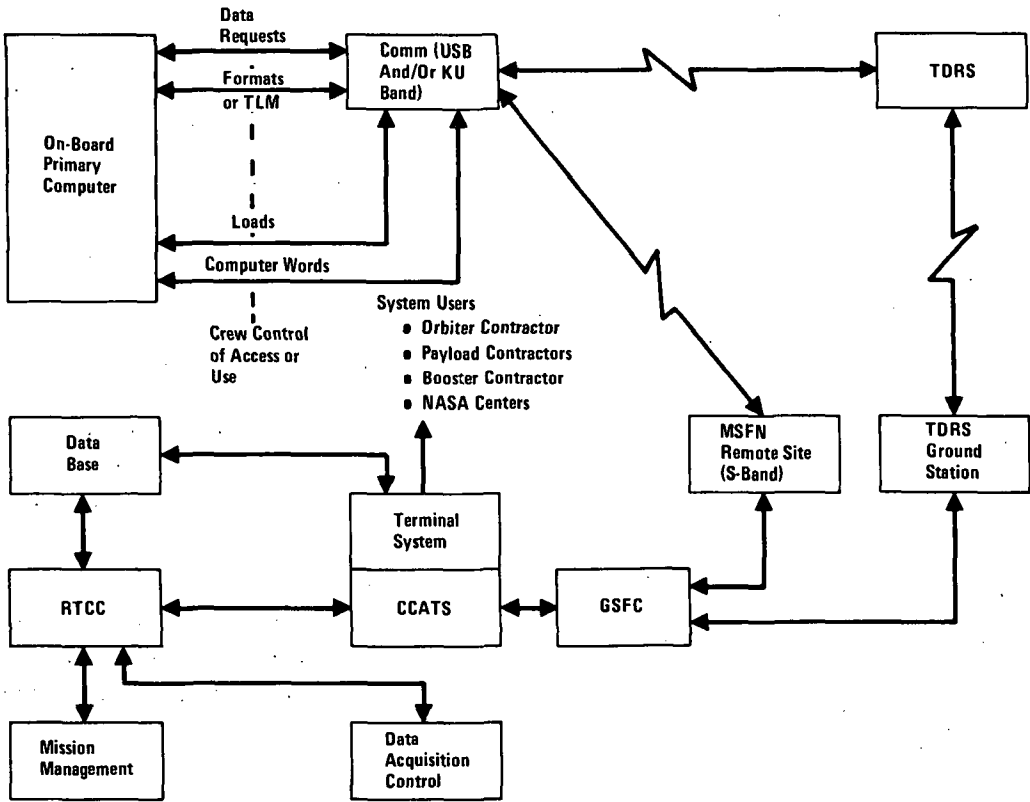

The addition of the TDRS to the network and impact of payloads must also be considered in considering the degree of autonomy.

Degree of Use of TDRS

The TDRS introduces a positive and negative element into the program. The "any time" access would allow a greater reliance on ground support. The goal of autonomy dictates less reliance. The allocation of data system functions as discussed above provides a meaningful use of TDRS with the space shuttle. Processing functions associated with the vehicle systems and its immediate mission environment should be allocated onboard. Other processing functions which tend to cause mission to mission software changes should be allocated to the ground with the TDRS used to access the data in the time interval required.

Allocate Payload Operations and Checkout to the Ground

Payload varies from mission to mission and so will the payload operations and checkout software. Use of the shuttle capability to bring the payload back if it does not work must be considered in conducting data system trades in this area. Crew training associated with payload checkout and operations must also be addressed. A software package for each payload will complicate the onboard system which has the primary function of delivering or returning payload to or from orbit. Software for vehicle function can be continually refined and improved. The introduction of ex-

ternal systems software for payload checkout and operations will only complicate the onboard software development. Processing associated with checkout and operations of payloads should be allocated to the ground data system because of

- Crew training
- Software development of onboard systems from mission to mission
- Any time access of TDRS
- Availability of experts for assistance
- Calibration standards
- The ground must interface the payload for data retrieval anyway
- Use the "any time access" capability of TDRS as a major item of trade when assessing ground data processing vs onboard data processing

- Allocate payload checkout and operations functions to the ground data system (Deployment and its associated functions to the vehicle)

AREAS OF CONCENTRATION FOR MK II AVIONICS CONCEPT WHICH IMPACT GROUND DATA SYSTEM

- **Allocate Certain Systems Mgmt Functions Onboard**
- **Allocate Certain Trajectory Mgmt Functions Onboard**
- **Transfer Only Those Mission Mgmt Functions Onboard Which are Considered Mandatory**
- **Use the "Any Time Access" Capability of TDRS as a Major Item of Trade When Accessing Ground Data Processing Versus Onboard Processing**
- **Allocate Payload Checkout & Operations Functions to the Ground Data System**

Preliminary analysis concerning trade-off of major ground support functions both on this study and previous studies conducted in mission operations indicate that certain functions could be allocated to the onboard data system which would contribute to the autonomy of the shuttle vehicle and increase its independence from the MCC. While much additional study is required to establish a positive position in terms of cost, safety and reliability, the following preliminary results are submitted:

Mission Management

- Allocate those functions associated with management of the vehicle and vehicle systems to the onboard data management system (crew activities scheduling, contingency planning (problem immediate), Reentry scheduling)
- Allocate functions associated with overall mission objectives with the ground data system (mission planning, mission scheduling, reentry and landing coordination, weather, biomedical monitoring and diagnostics).

MISSION MANAGEMENT CONCEPT – MK II

Allocate Functions Associated With Mgmt of the Vehicle & Vehicle Systems to the Onboard Data Mgmt System

- **Crew Activities Scheduling**
- **Contingency Planning (Immediate Vehicle Problem)**
- **Reentry Scheduling (Emergency Entry)**

Allocate Functions Associated With Overall Mission Objectives to the Ground Data System

- **Mission Planning**
- **Mission Scheduling**
- **Reentry & Landing Coordination**
- **Weather**
- **Biomedical Monitoring & Diagnostics**

Systems Management

- Allocate the mission time systems management functions to the onboard data management system (system checkout (priority item), system monitoring (priority item), real time control (priority item), system configuration control, communications control, and consumables control).
- Allocate the long term system management to the MCC (maintenance planning, trend analysis, consumables management, communications access, failure analysis, and payload operations).

SYSTEMS MANAGEMENT – MK II

Allocate the Mission Time Systems Mgmt to the Onboard Data Management System

- **System Checkout**
- **System Monitoring**
- **Real-Time Control**
- **System Configuration Control**
- **Communications Control**
- **Consummables Control**

Allocate the Long Term System Mgmt to the MCC

- **Maintenance Planning**
- **Trend Analysis**
- **Consummables Management**
- **Communications Access**
- **Failure Analysis**
- **Payload Operations**

Trajectory Management Concept

- Allocate those trajectory areas which deal primarily with preprogrammed functions to the onboard data management system (IMU alignment, maneuver planning, vehicle ephemeris, rendezvous planning, and entry and landing).
- Leave those functions associated with mission time trajectory to the ground support system (multiple ephemerides, ephemeris calculations, navigation updates, guidance updates, retro-fire maneuver updates, time updates, EMU updates, and abort trajectory analysis).

TRAJECTORY MANAGEMENT CONCEPT – MK II

Allocate Trajectory Areas Which Accomplish the Following Functions to the Onboard Data Management System :

- **IMU Alignment**
- **Maneuver Planning**
- **Rendezvous Planning**
- **Entry & Landing**

Allocate Those Functions Associated With Mission Time Trajectory to the Ground Support System :

- **Ephemeris Calculations**
- **Navigation Updates**
- **Guidance Updates**
- **Retrofire Maneuver Updates**
- **Time Updates**
- **EMU Updates**
- **Abort Trajectory Analysis**
- **Vehicle, Target & Payload Ephemerides**

The first of four pressure-fed boosters studied is the Model 979-141, - an expendable two-stage booster. The first stage consists of three strap-on tank/engine modules which are expended and dropped at a velocity of 2315 fps. The second stage, is expended and dropped at a velocity of 5157 fps. Thrust vector control of up to six degrees per engine is effected by ON-OFF injection of N_2O_4 into 16 nozzles (LITVC) located around the throat of each engine expansion chamber. This control capability precludes the need for tail fins that might otherwise be required to minimize upsetting moments that occur when boosting through the high wind shears often found at about 30,000 ft altitude.

Navigation, guidance, and control intelligence

is obtained from orbiter-borne equipment. Triple thread redundant control signals are hardwired from the orbiter avionics bay to the TVC voter where the dominant ON-OFF signal is selected for activation of the TVC valves.

A multiplexed instrumentation system is employed for developmental, operational, and pre-flight checkout instrumentation. This instrumentation system is also used to feed data on booster status to the orbiter. Abort decisions and sequencing are effected by the orbiter guidance computer and crew.

Squib-activated, silver-zinc batteries are used in the booster stages to power the instrumentation, telemetry transmitter, destruct system, and to power the LITVC valves.

MODEL 979-141 UDMH/N₂O₄ 2-Stage Expendable, Pressure Fed Booster

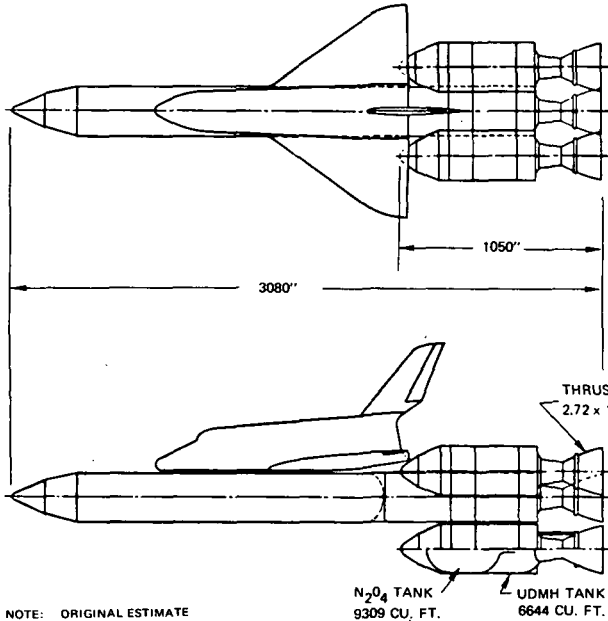

NOTE: ORIGINAL ESTIMATE

DESIGN CHARACTERISTICS

	1ST STAGE	2ND STAGE
GLOW	6,530,000 LB	
BLOW	3,884,000 LB.	1,296,000 LB.
OLOW	1,350,000 LB.	
W _{pb}	3,289,000 LB.	1,097,000 LB.
λ'	0.847	
V _{STG.}	2,315 FPS	5,170 FPS
BOOSTER WT.		
INERT	545,000 LB.	199,000 LB.
ORBITER WT.		
INERT	211,300 LB.	
LANDING	188,500 LB.	

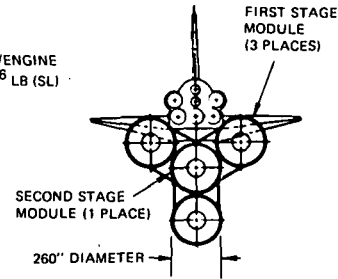

The Model 979-142 pressure-fed booster is identical to the two-stage 979-141 described on the previous page with one major exception: the first stage only is soft-landed by parachutes and recovered from the sea for reuse. Since the average life of a booster motor is about twenty uses, the older boost modules, previously used on the first stage, are expended as second stages, because the cost of recovery of the older motors is not justified.

The requirement to recover the 979-142 adds the following requirements to the booster avionics, as described for the 979-141:

- A parachute sequencer, using thrust chamber pressure decay as the initiating signal, is added
- A UHF recovery beacon is added to each of the three boost modules, to aid the recovery ship in locating the units after splash-down
- Special salt water protection techniques are used on cable connectors and electronic packages. The added cost of using O-ring seals, corrosion resistant metals, and potting of cable connectors is estimated to be \$25,000 per booster

MODEL 979-142 UDMH/N₂O₄, 2-Stage Recoverable Pressure Fed Booster

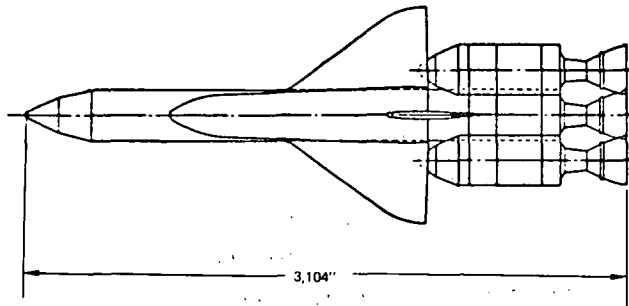

NOTE: ORIGINAL ESTIMATE

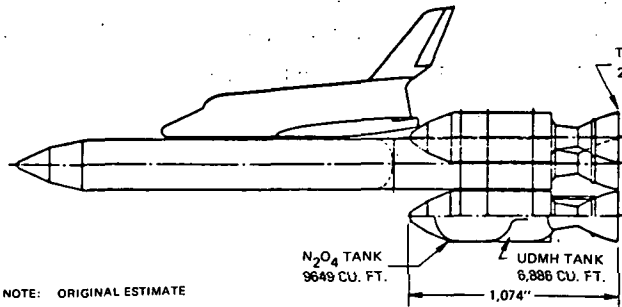

THRUST/ENG. =
 2.86×10^6 LB (S.L.)

SECOND STAGE
MODULE (1 PLACE)

260" DIAMETER

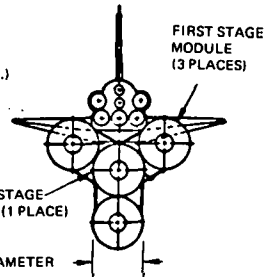

DESIGN CHARACTERISTICS

	1ST STAGE	2ND STAGE
GLOW	8,853,000 LB.	
BLOW	4,132,000 LB	1,370,000 LB
OLOW	1,350,000 LB.	
W _{pb}	3,431,000 LB.	1,137,000 LB.
λ	0.830	
V _{STG}	2,279 FPS	5,165 FPS
BOOSTER WT.		
INERT	702,000 LB	233,000 LB.
IMPACT.	682,000 LB	...
ORBITER WT.		
INERT	211,300 LB.	
LANDING	188,500 LB.	

The Model 979-143 is a single-stage booster consisting of seven identical engines fed by a single tank assembly of UDMH and N_2O_4 . The entire stage is recovered by deploying drogue and main parachutes after a controlled re-entry at 70° deg angle-of-attack. Recovery of the attitude control system, recovery beacon, destruct receivers, TVC and RCS drive electronics, telemeter receiver and instrumentation is aided by special salt water protection techniques that minimize refurbishment costs.

UDMH/N₂O₄, SINGLE STAGE, MODEL 979 - 143

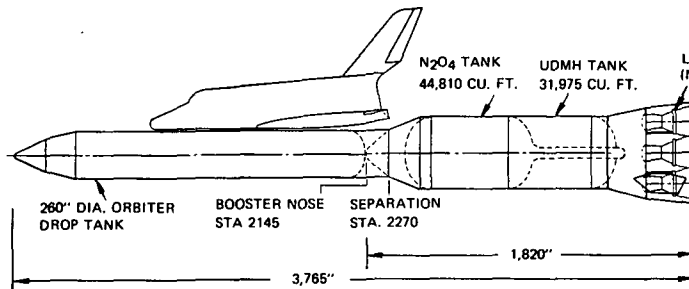
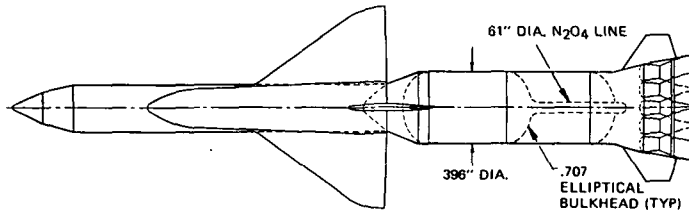

NOTE: ORIGINAL ESTIMATE

DESIGN CHARACTERISTICS

GLOW	= 7,592,000 LB.
BLOW	= 6,242,000 LB.
OLOW	= 1,350,000 LB.
PROPELLANT WEIGHT	= 5,280,000 LB.
	5,029,000 LB. ASCENT
	251,000 LB. LITVC
λ'	= 0.846
$V_{STG.}$	= 5,354 FPS
BOOSTER WT.	
INERT	= 963,000 LB.
IMPACT	= 932,000 LB.
ORBITER WT.	
INERT	= 211,300 LB.
LANDING	= 188,500 LB.

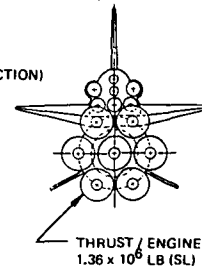

The Model 979-144 like the Model 979-143, is a single-stage booster consisting of seven identical engines fed by a single tank assembly. The major difference between the 979-144 and the 979-143 is that LOX-RP propellants are used instead of the UDMH and N_2O_4 propellants used in the 979-143. The LOX-RP propellant, although lacking the storability feature of UDMH - N_2O_4 , is free of the toxicity problem of UDMH - N_2O_4 , and is a lower cost propellant to manufacture.

The avionics and recovery techniques for the 979-144 are essentially identical to that selected for the Model 979-143.

LOX/RP - 1, SINGLE STAGE, MODEL 979 - 144

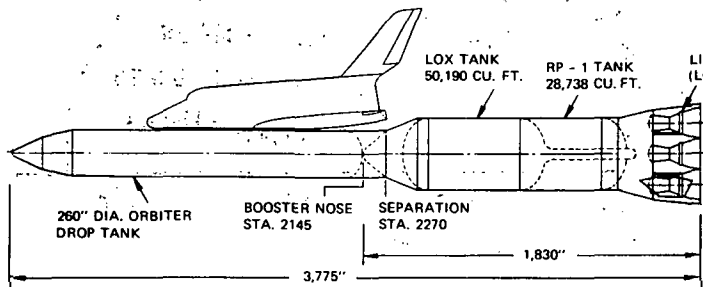
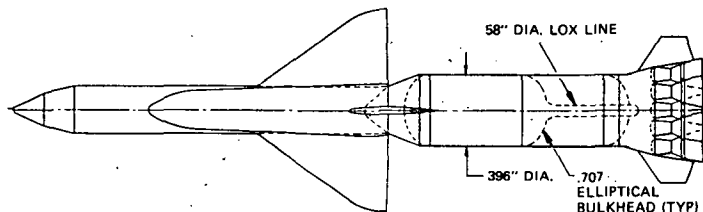

NOTE: ORIGINAL ESTIMATE

DESIGN CHARACTERISTICS

GLOW	= 6,945,000 LB
BLOW	= 5,595,000 LB.
OLOW	= 1,350,000 LB.
PROPELLANT WEIGHT	= 4,700,000 LB.
	4,476,000 LB. ASCENT
	224,000 LB. LITVC
λ'	= 0.840'
V_{STG}	= 5,372 FPS
BOOSTER WT.	
INERT	= 895,000 LB.
IMPACT	= 865,000 LB.
ORBITER WT.	
INERT	= 211,300 LB.
LANDING	= 188,500 LB.

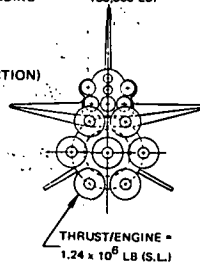

BOOSTER TRAJECTORY MODEL

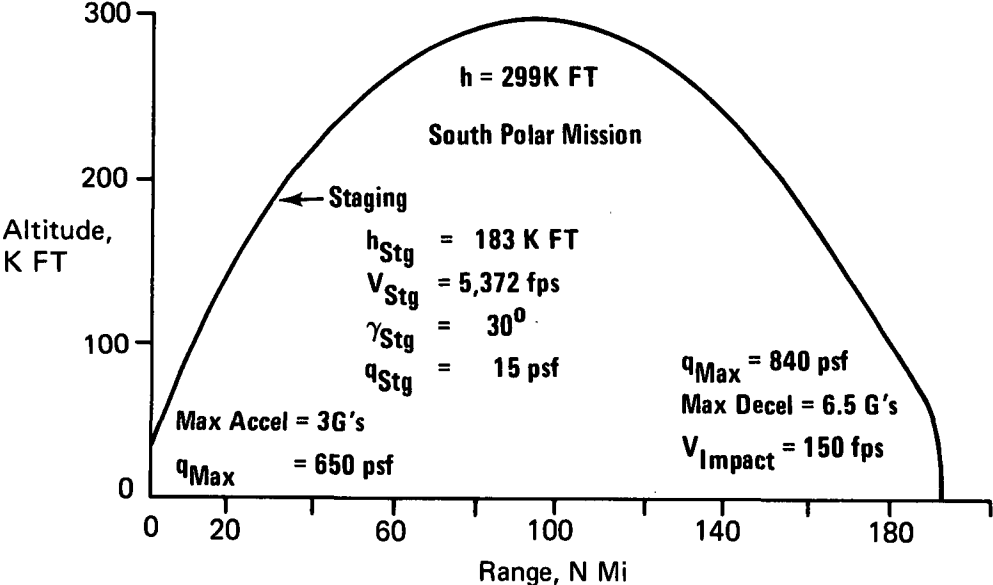

REENTRY TRAJECTORY

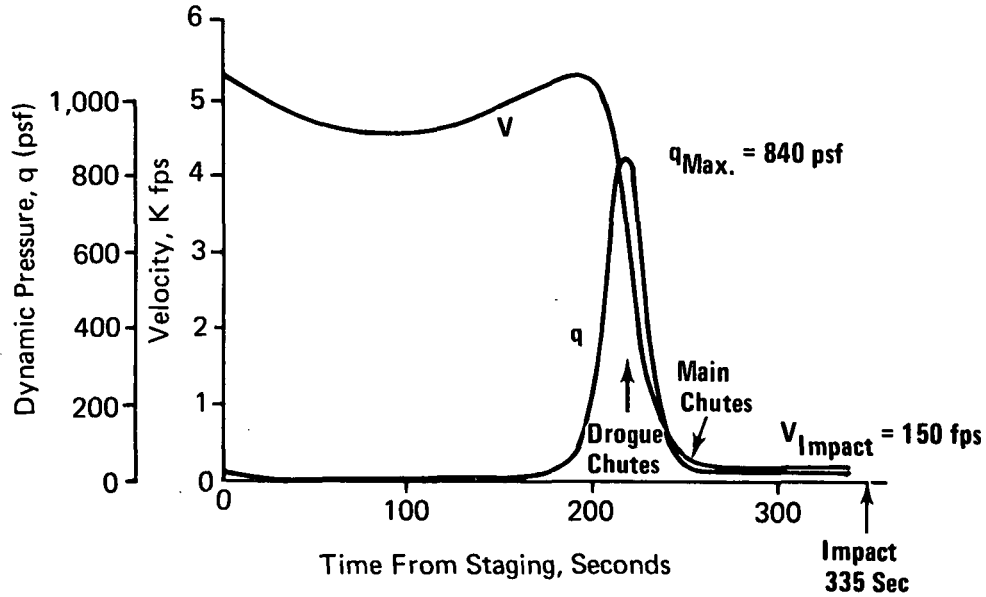

RECOVERY SEQUENCE

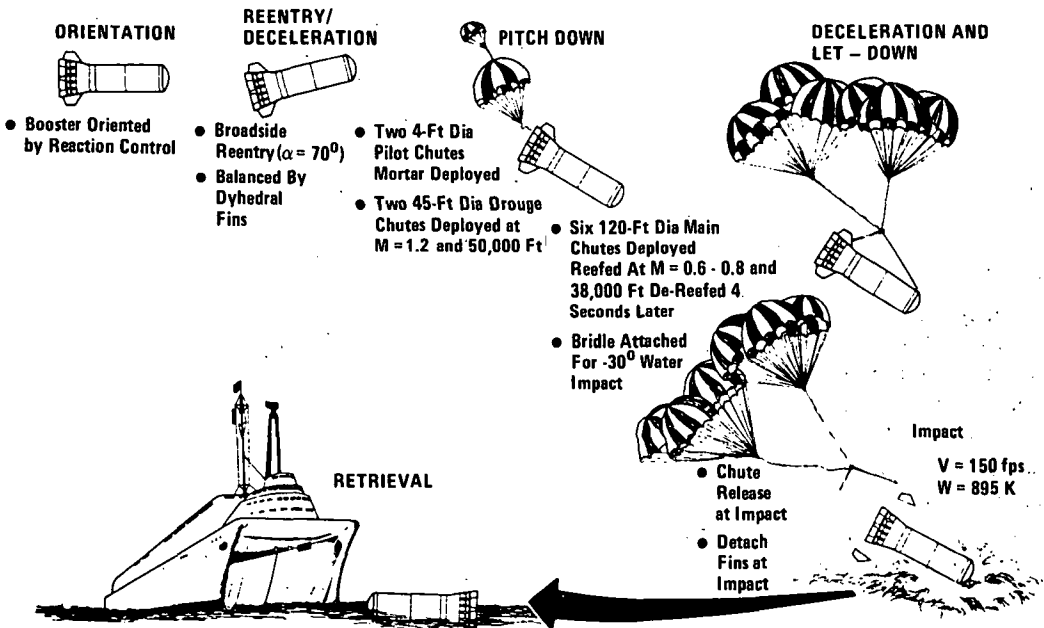

A Monte Carlo analysis was conducted on statistics of BRB wear-out and attrition. All cases analyzed assumed 445 flights and assumed that the probability of loss was independent of the flight history or design life of the booster. One hundred simulations were run at each point analyzed to provide a reasonable sample size.

Parametric results are shown on the facing page. These results provided the basis for determining the number of boosters required for the operational program. The total number of boosters required is based on the following assumptions:

1. The booster has a useful life of 20 flights.
2. The booster reliability is 0.99.
3. The recovery system reliability is 0.98.
4. The probability of favorable weather in the

recovery area is 0.995.

5. The number of boosters can be based on 50% probability of completing the 445 reusable launches without depleting the booster stockpile.

The required number of boosters for each of the four programs is shown in the table below.

**NUMBER OF BOOSTERS REQUIRED FOR 460
FLIGHTS**

(Loss Probability = 0.035 per flight)

	PROGRAM DESIGNATION			
No. of Boosters	-141	-142	-143	-144
	460	127	45	45

DETERMINATION OF REQUIRED NUMBER OF BALLISTIC REUSABLE BOOSTERS

P = 0.025 (Loss Probability Per Flight)

P = 0.05 (Loss Probability Per Flight)

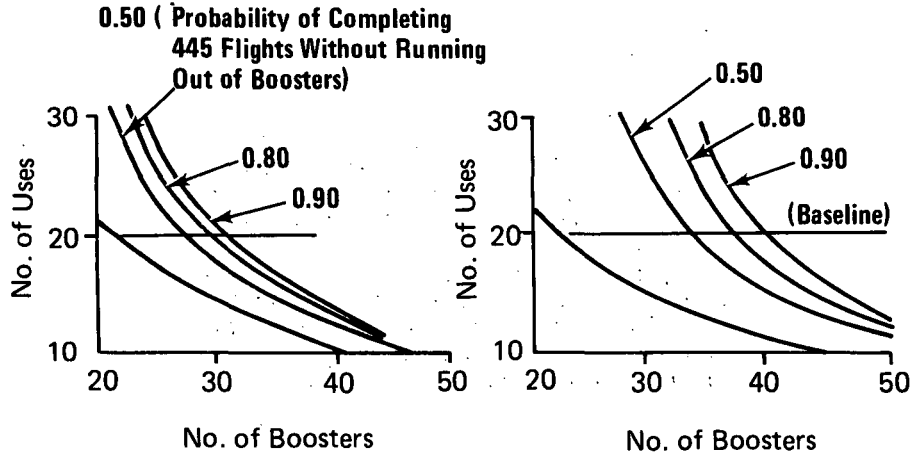

Major avionics trades for the ballistic recoverable booster involve the difference in redundancy requirements between the boost and recovery phases. The orbiter G&N equipment has the capability to effect control of the mated vehicles and to do so with the required level of redundancy.

When considering recovery of the pressure-fed booster, one of the techniques involves an active attitude control system employing reaction control jets, requiring some booster-located guidance and control equipment, albeit crude compared to the boost phase G&N requirements. Equipment costs favor the selection of orbiter-located G&N for the boost phase function, with a simple single thread attitude control system to effect a high drag re-entry prior to chute deployment.

AVIONICS TRADES

- **G&N Redundancy**
 - Boost? – Reentry?
- **Boost G&N**
 - Orbiter vs Booster

Considering the redundancy question by itself, independent of the "orbiter versus booster G&N for boost phase" issue, two basic techniques are available: (1) Triple masking redundancy employing simple majority vote, and (2) dual standby redundancy using computer interdiagnostic techniques. Although the dual standby redundancy technique is basically capable of providing higher reliability with less hardware than the triple-voted method, greater experience exists with the voting method, thus it was selected at this time because of its lower development risk factor. Since this reasoning applies for either the orbiter or booster avionics, it follows that triple redundancy is recommended whether orbiter-located or booster-located G&N equipment is used for the boost phase.

Redundancy of the booster avionics for the re-entry phase can be relaxed relative to the boost phase because the man-rating requirement is removed at orbiter-booster separation. With the re-entry attitude control phase lasting approximately five minutes, the failure rate for single-thread redundancy is considered adequate.

G&N REDUNDANCY

- **Boost**
 - Dual Monitored “Off-Line-Redundant” Higher Risk and Lower Cost is Not Obvious
- **Re-Entry**
 - Single Thread Redundancy Contributes Approximately One Failure in 1000 Hr of Flight
 - Vehicle Uses System 3 Min Each Flight Max No. of 20 Flights
 - Therefore Probability of Vehicle Loss Due to Avionics Is 1 in 10^{-3} vs Assumed Vehicle Loss Due to Recovery of 1 in 20
- **Recommendation**
 - Single Thread Redundancy Required for Re-Entry
 - Triple Voted Required for Boost

Boost Phase G&N in Booster

Beginning with the requirement that an attitude reference unit (or platform) and a flight control computer (or G&N computer) are required in the booster for attitude control during re-entry, then two additional platforms and two additional G&N computers are required to meet the triple redundancy requirement for the boost phase. (Note: The re-entry attitude control system will require simpler equipment than a single-thread of the boost phase G&N equipment; however, since the re-entry controller has not yet been fully defined, and as an aid to getting a first-cut on price comparison, a boost phase G&N system was assumed for the re-entry controller.)

Boost Phase G&N in Orbiter

The additional memory and software required in the orbiter prime computer for engine sequencing, abort logic, and thrust vector control of the booster induce additional costs to the orbiter that are traded against the cost savings in the booster. An additional 75 lb of inert weight, added to the orbiter over a ten-year life of the program (assuming a traffic model of 445 missions), moderates the advantage of using the orbiter G&N equipment for the boost phase control of the booster.

The recommendation resulting from this technical trade is to utilize the orbiter's G&N equipment for boost phase guidance of the mated vehicles; and a dedicated special-purpose controller for the re-entry phase of the booster.

IMPLEMENT G&N IN ORBITER OR BOOSTER?

- Δ In Booster

2 G&N Platforms @ 83K = 166K

2 G&N Computers @ 45K = 90K

Subtotal = 256K

46 Ship Sets @ 256K per Ship = 11,776K

100 Lb @ \$5K per Lb in Booster = 500K

Booster Total = 12,276K

- In Orbiter

G&N Platforms and Computers in Orbiter = 0

*Orbiter Program Cost = 5,500K

*75 Lb @ \$32.4K per Lb in Orbiter = 2,430K

Orbiter Total = 7,930K

Life Cycle Cost Would Appear to Reinforce the Trade.

*See Interim S-IC in Final Report

The navigation, guidance and control intelligence is obtained from orbiter-borne equipment, which is triple-threaded using the simple majority voting technique for redundancy management. The control signals for the LITVC function in the aft of the booster are voted at the input to the single-thread electronics required to drive each of the ON-OFF LITVC valves.

The recovery technique selected for the Model 979-144 requires a reaction controlled attitude control system: the booster has two aerodynamically stable modes during re-entry, one at 0 deg angle-of-attack, and another at 70 deg angle-of-attack. As a means to minimize the parachute development problem the 70 deg mode was selected because it has a much lower ballistic coefficient (W/C_{DA}) than the 0 deg re-entry attitude. However, in order to achieve the 70 deg attitude for re-entry and to dampen oscillations during re-entry, an attitude reference platform (or its equivalent) is required. A simple analog

or special-purpose digital computer is adequate to signal the reaction control system (RCS). The base-line RCS is a bi-propellant, operating at a thrust chamber pressure of 98 psi; however, an alternate RCS which uses the ullage gas (100 psi) available from the main fuel tank, is attractive. The RCS consists of two, 500 lb thrust engines in pitch, two, 500 lb thrust engines in yaw, and four, 250 lb engines in roll. A parachute sequencer, utilizing total and static pressure sensors, deploys the two drogue chutes at 50,000 ft (M 1.2) altitude and the six main chutes at 56 psf (M 0.6-0.8).

A multiplexed instrumentation system is employed for developmental, operational, and preflight checkout instrumentation. This instrumentation system is also used to feed data on booster status to the orbiter. Abort decisions and sequencing are effected by the orbiter avionics and crew.

BALLISTIC RECOVERED BOOSTER BOOST GN&C IN ORBITER

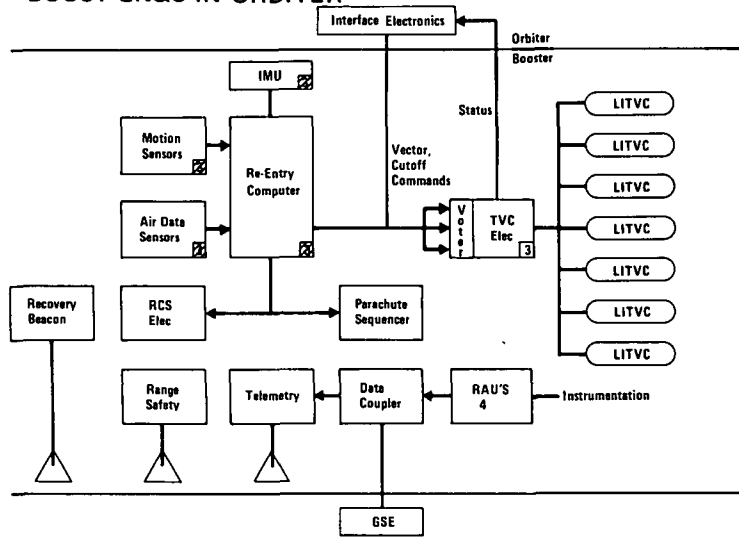

 Required if Orbiter Is Not Used For Control During Boost



HARDWARE
COMPARISON

Using results derived from RCA's PRICE program (a computer modeling technique for projecting the cost of electronics) it is possible to quantitatively evaluate the alternates of selecting FAA, MIL, or Space Standards for space shuttle avionics. The illustration compares costs of the several approaches normalized to the development cost of an FAA equipment. These results are typical of an all-electronic equipment. Production costs are generated for a run of 34 units. The reliability associated with each standard is shown, normalized to space reliability. Units to Maturity — reflects the typical number of units for each class of construc-

tion needed to get a mature product. Maintenance costs are developed assuming a 10,000 hr total unit life with a 10% of unit cost attributed to each failure. The remainder of the chart shows in summation several possible combinations of life cycle costs for a given unit. The 20% development line represents a good approximation to the cost of an "off-the-shelf" equipment which requires some modifications for the shuttle application. From these results, one can compare the cost of various strategies considering only the cost of equipment and its maintenance. This is not the only cost. Another cost is considered on the next page.

FAA/MILITARY/SPACE COMPARISON

	<u>FAA</u> ¹	<u>MIL</u> ²	<u>SPACE</u> ³
Development Costs	1.0	1.3	2.3
Production Costs (34)	.8	1.2	1.9
Reliability (FR)	5.0	2.5	1.0
Units to Maturity	200.	50.	10.
Maintenance (10% per F)	1.6	1.2	.8
Prod + Maint	2.4	2.4	2.7
Dev + Prod + Maint	3.4	3.7	5.0
20% Dev + Prod + Maint	2.6	2.66	3.16

1. Standard commercial aircraft design standards (ARINC)
2. MIL-E-5400 (SST electronics probably fits here)
3. NASA Man Rated Equipment Standards

To assess the true impact of failure, we must consider vehicle aborts which result from equipment failure. For purposes of example, failure rates for a typical equipment have been selected. We assume that the FAA equipment has a failure rate of 2000 PPM and has an absolute cost as indicated on the previous slide. Under the conditions outlined, we can then establish a cost penalty per vehicle and a cost for a four-vehicle fleet which applies for aborts resulting from equipment failure. Note the significant differences between the various standards.

FAILURE PENALTY

Example:

- Failure Rate $\left\{ \begin{array}{l} 2000 \text{ PPM} - \text{FAA} \\ 1000 \text{ PPM} - \text{Mil} \\ 400 \text{ PPM} - \text{Space} \end{array} \right\}$
- 100 Missions for 100 Hours
- Triple Redundancy – Two Failures = Abort
- Abort Cost = \$5 M

Then:	<u>Cost Per Vehicle, \$K</u>	<u>Four Vehicle Fleet, \$K</u>
FAA	450	1800
Mil	115	460
Space	25	100

This table shows the results of combining the figures derived in the previous two charts. Column 1 shows the life cycle equipment cost listed in increasing order. Column 2 applies the abort penalty derived for a four-vehicle fleet. Column 3 sums the two figures. As can be seen, MIL standards is least costly for new design. For modified piece, MIL again is most effective but space is very close, and finally, an existing space box is the least costly of all. Thus, a policy of selecting MIL equipment for the shuttle appears to make economic good sense unless an existing space design is available.

FAA/MILITARY/SPACE COMPARISON (CONT)

	<u>Acq Maint, \$M</u>	<u>Abort, \$M</u>	<u>Total, \$M</u>
Existing FAA	2.4	1.8	3.8
Existing Mil	2.4	.46	3.0
Modified FAA	2.6	1.8	4.4
Existing Space	2.7	0.1	2.8
Modified Existing Mil	2.8	.46	3.2
Modified Existing Space	3.2	0.1	3.3
New FAA	3.4	1.8	5.2
New Mil	3.7	.46	4.2
New Space	5.0	.1	5.1

CONCLUSIONS – LOW COST RISK AVIONICS

- **Development Costs more than Shuttle Production**
- **The Management & Systems Engineering for Redundancy Cost More than the Added Hardware**
- **FO/FS Makes Economic Good Sense**
- **Autonomy Principally Affects On-Board Software Costs**
- **Autonomy Must Be Defined on a Mission Basis**
- **Software Dominates DM Hardware Costs by at Least 4:1**
 - **Do What it Takes in the Hardware to Minimize Software Cost**

CONCLUSIONS – LOW COST RISK AVIONICS (CONT)

- **Data Bus Should Be Used for Data Acquisition & Probably for G&C**
- **Digital Technology, in the Long Run, Will Be Cheaper, Lighter Than Equivalent Analog Function**
- **Derived Low Cost Avionics Reduces Risk More Than Identified Cost**
- **No Hardware Technology Breakthroughs Required**
- **Ballistic Recoverable Booster Will Significantly Reduce Avionics Cost**
- **Avionics is an Expensive Place to Reduce Weight (\$100 - 500K per Lb)**
- **Large Computer Complex not Required for First Horizontal Flight**

SPACE SHUTTLE STUDY COST/RELIABILITY ANALYSIS

- **Redundancy Analysis**
- **Ground Support Impact**
- **Reliability Tradeoffs**
- **Life-Cycle Cost Evaluation**

The degree to which redundancy is applied to the onboard shuttle avionics is a direct determinant of hardware and software program costs. Thus, the use of redundancy on each avionics function and each LRU must be justified on a basis of program needs and economy. An effective way of accomplishing this is to assign each avionics function (and each LRU) one of the three critically levels listed. As a function of criticality, the basic definition of redundancy requirements is as shown. This represents a minimum level of redundancy in each criticality level. Any additional redundancy must be justified on a life cycle cost economical basis. General Electric studies have shown that approximately 40% of shuttle avionics LRU functions are crew safety critical, 45% are mission critical, and 5% are for crew convenience. In this manner redundancy (and cost) is significantly reduced when compared to the original FO/FO/FS requirement for all functions.

LRU CRITICALITY ASSIGNMENT IMPACT ON REDUNDANCY

Criticality	Redundancy Impact
1 (Crew Safety)	Continue Mission with Two or More Units Operative; Abort if Only One Unit is Operative
2 (Mission Critical)	Continue Mission if One Unit is Operative; Option to Abort if No Units are Operative
3 (Convenience)	Continue Mission if No Units are Operative

The degree of criticality for LRU's impacts not only the the redundancy as described, but also the degree of testing required, i.e., the higher criticality LRU requires more qualification testing. This shows the testing impact for each criticality level taking into consideration that off-the-shelf equipment unmodified or modified, or new development equipment meeting either FAA, airborne military, or space requirements may be used for the shuttle avionics. Thus, via LRU criticality assignment the resultant testing impact reduces the overall avionics testing costs.

LRU CRITICALITY ASSIGNMENT IMPACT ON TESTING

Criticality	Testing Impact
1 (Crew Safety)	Full Qual for New Developments; For Off-the-Shelf Hardware Qual Test Only Parameters Where SSS Environment is More Severe
2 (Mission Critical)	Full Qual for New Developments; Certification by Similarity for the Off-the-Shelf Equipments
3 (Convenience)	Use Only Certification By Similarity or Based on Development/Acceptance/Flight Test Experience

General Electric investigated the cost/performance relationship of using existing ACE, modifying ACE or developing a new Ground Checkout System, Unified Test Equipment (UTE).

Conclusions reached are that UTE is the most cost effective system, Ground Checkout costs are a significant driver, approximately \$120M for the DDT&E and delivery of approximately ten systems to the field.

Of special interest is the fact that UTE costs are independent of the four onboard avionic systems considered.

UTE can be designed to minimize the number of consoles and operators. Through modular building block techniques and common designs, each system installation can match the particular site requirements.

GE AVIONICS GROUND SUPPORT SYSTEM

- **Potential Avionics Cost Driver**
- **UTE is Cost Effective Versus ACE**
- **UTE Cost Not Sensitive to Onboard Avionics Configuration**
- **UTE Cost Advantages**
 - **Low First Cost**
 - **Comparatively Low Operating Costs**
 - **Cost Effective Growth Capability**
- **UTE Functional Advantages**
 - **Automation**
 - **Modularity**
 - **Commonality**
 - **Flexibility**

In 1962, J. T. Duane, at the General Electric Motor and Generator Department examined the performance of electromechanical and hydromechanical products (such as motors, generators, turbines, water-wheels, etc.) which had undergone many thousands of test hours. His efforts resulted in the formulation of a technique for predicting the reliability growth of complex equipment as given by the log-log equation on the illustration. The main axioms determined as a result of this study are shown. In 1968 General Electric's Aerospace Electronics Systems Department initiated a study to determine the applicability

of the Duane MTBF growth equation to aerospace electronics equipment programs. GE-developed avionics on the F-111 and P-3C programs and historical data on various Air Force and Navy programs for specific avionics equipments were studied and the results confirmed the applicability of the Duane reliability growth model. During 1969 and 1970 GE tested and verified this model by implementing its principles on several current avionics programs. The evaluation results from the Reliability Planning and Management (RPM) technique which is briefly described next.

RELIABILITY GROWTH MODEL

- **MTBF = $at + b$ On Log-Log Scales**
- **Axioms**
 - **Reliability Improvement of Complex Equipment Follows a Mathematically Predictable Pattern**
 - **Reliability Improvement is Approximately Inversely Proportional to the Square Root of Cumulative Operating (Test) Time**
 - **For a Constant Level of Corrective Action Effort & Implementation, Reliability Growth Closely Approximates a Straight Line on Log-Log Scales**
 - **These Relationships Permit use of a Simple Technique for Monitoring Progress Toward a Predetermined Reliability Goal**
- **Data Source**
 - **Initial Patterns Developed in Early 1960's from Data on Five Divergent Groups of Products Based on Typically 50,000 Hours Operating Data**
 - Two Hydromechanical Devices, Two Complex Aircraft Generators,
One Aircraft Jet Engine
 - **Pattern Confirmed by AESD to be Applicable to Avionics from Data On Four Programs**

Reliability Planning and Management (RPM) is a new methodology developed by GE to relate reliability criteria to program planning options and constraints. It incorporates predicted reliability growth rates and demonstrated reliability growth rates, the latter based on visible evidence of performance, enabling the dimensioning of time, resources, assets, and facilities required to bridge the gap between the sterile specified reliability requirements and the practical reality of program execution.

Based on GE evaluation and application experience, certain axioms must be accepted to apply RPM:

- That no design is ready to release for product manufacturing until (using MIL-Handbook 217A failure rates) a reliability prediction of 125% or more of the specified MTBF requirement is established
- Based on historical data, initial product performance will be approximately 10% of the predicted value

- Reliability growth is predictable and alpha varies from approximately 0.1 when a contract has no specific reliability improvement requirements to approximately 0.6 when an ambitious reliability improvement program is implemented
- Where the min/max alpha growth lines intersect, the required MTBF determines the max/min reliability demonstration test hours required to meet the specification.
- The option (reliability program, number of units to be tested, facilities, etc.) which best meet program needs economically and within the program constraints is planned in detail, implemented and managed.

These axioms permit the portrayal of RPM on one simple chart as shown here. This is the Reliability Planning and Management Model as presented by GE to government and industry.

RELIABILITY PLANNING & MANAGEMENT

- Initially Released Design - Approx 10% of Predicted Inherent Capability
- Growth-Plan Program Based on Duane Growth & RPM Tradeoffs
- Prediction-Simplify Design Until MIL-HDBK-217 Prediction is 125% of Reqmt
- Screening/Processing-Adjust Levels to Meet MTBF Reqmt

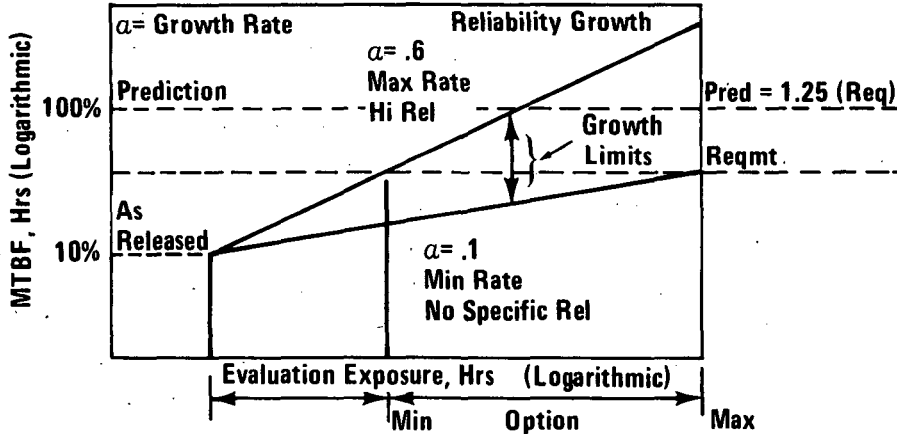

Prog Planning Options

- Equipments
- Facilities
- Level of Corr Action

Prog Constraints

- Chg Limitations, i.e., Config Control
- State of the Art
- Dollars
- Time



Shown here are the actual RPM results on APQ-113 Attack Radar used for the F-111 program. RPM was applied about midprogram and there was excellent model correlation as shown. The initial equipment configuration had 16,000 parts, a predicted MTBF of 90 hr compared to the 137 hr minimum requirement, and an actual initial demonstrated 9 hr MTBF. RPM analysis indicated that this initial configuration would not meet the specified MTBF within the program time and funding constraints. Thus, the equipment was redesigned into a reduced parts count configuration now having 10,000 parts, a 180 hr MTBF prediction, and a

plan for extended parts and product screening. As can be seen, the initial demonstrated MTBF was approximately 18 hr (10% rule) and the actual reliability growth rate was an alpha of 0.5 (high reliability program effort). The specified MTBF was achieved after approximately 9,000 hr of Reliability Demonstration testing and consistently improved thereafter. Note when configuration change constraints were applied via implementation of configuration control on production units, this lower flexibility also resulted in an expected lower reliability growth rate as shown.

RPM MODEL – PROGRAM 1

- Analog/Digital
- 10,000 Components
- LRU Burn-In
- Component Part Screening
- Reliability Demo & Acceptance Per MIL-R-26667

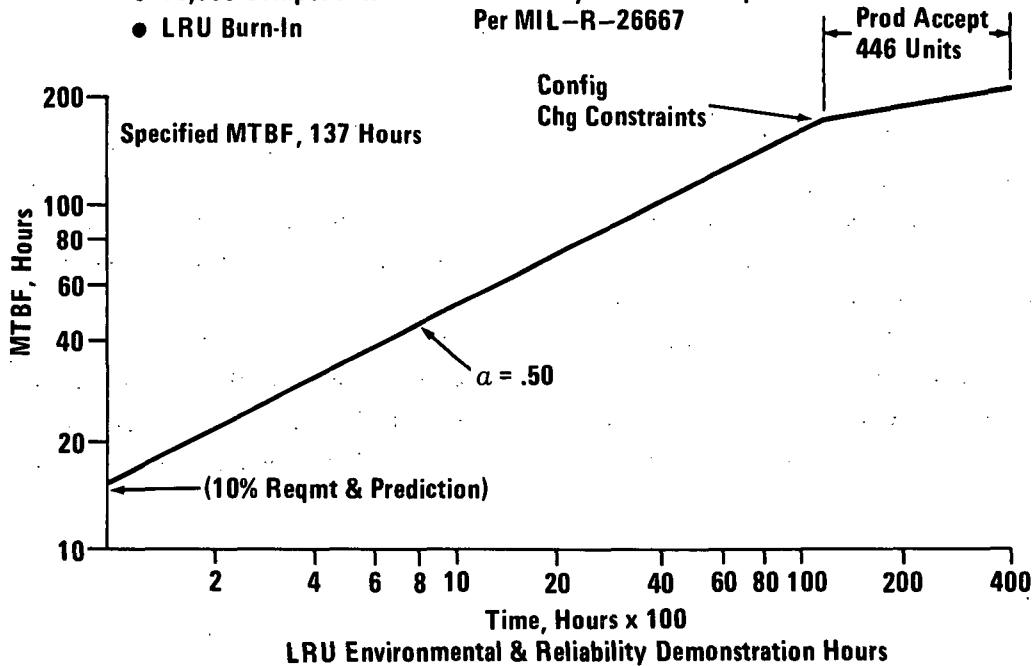

The RPM model for the AN/APQ-113 Attack Radar as shown on the previous page was applied by GE into a major design improvement program. This improvement represented a 20% design-modified version of the AN/APQ-113 Radar, forming the new AN/APQ-114 Radar. Using RPM planning analysis, a composite model based on the predicted performance of a mixture of changed and unchanged parts resulted in an initial MTBF estimate of 33 hr. A conservative reli-

ability growth slope of alpha equals 0.375 was selected yielding a required 3,750 hr test program. This plan was negotiated as part of the contract with incentives and was implemented. As can be seen, correlation between performance and plan was excellent. The actual alpha was 0.48. After completing the 3,750 hr demonstration, the 21 production systems which were subjected to Reliability Acceptance Testing measured 212 hr MTBF, substantially exceeding the specified MTBF.

RPM MODEL PROGRAM 2

EVENT HISTORY

		Event	1966				1967				1968				1969				1970			
			1	2	3	4	1	2	3	4	1	2	3	4	1	2	3	4				
H/w	Dev Models 3 Systems		█																			
	Prod (20% Change 84 Systems Hardware)								█													
Rel	Test & Fix (3750 Hours) 3 Systems					█																
	Prod Acceptance Test 21 Sys					MTBF = 212 Hr				█												

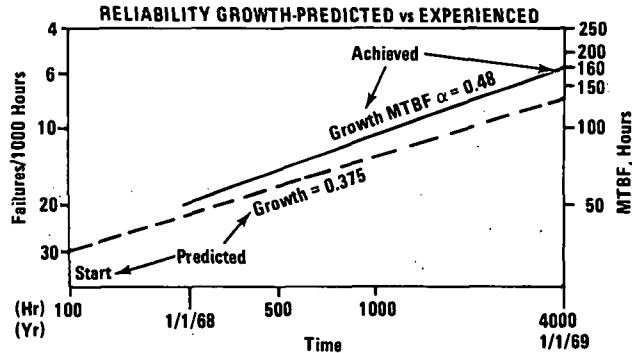

When applying general RPM analysis to the Space Shuttle low cost avionics objectives, certain guidelines become apparent as follows when also the low production volume is considered:

- New equipment designs should be avoided as much as practical in order to eliminate the cost and time needed to grow the reliability from the initial 10% of prediction (b) to full specified MTBF
- Achieve the Shuttle program time constraints by timely attainment of the required MTBF via optimum tradeoff between the reliability design/implementation, accelerated testing (step stress, overkill, etc.) and selection of number of units to be tested simultaneously
- Be certain that the predicted MTBF exceeds the actual Shuttle required MTBF by at least 25%
- Include in the RPM implementation plan an aggressive program of reliability problem identification, corrective action, and test validation
- Include in each Shuttle avionics equipment specification the requirement to plan and implement a reliability program using the RPM technique
- Measure and manage the Shuttle avionics reliability growth using RPM for the overall avionics system, each subsystem, and each LRU

RPM APPLIED TO SPACE SHUTTLE

$$(MTBF = \alpha t + b)$$

- **Beware of New Equipment Designs** (b)
Where Reliability Will Be Approx 10% of Prediction
- **Address Time Constraints** (t)
Through Accelerated Testing (Step Stress Overkill)
- **Accelerate Reliability Growth** (α)
Through Aggressive Problem Identification, Corrective Action & Test Validation
- **Assure That Substantive Rel Predictions Exceed Reqmts** (MTBF)
By Sufficient Margin to Enhance Achievability & Allow for Uncertainties
- **Optimize Level of Screening Tests** (MTBF)
Commensurate With Reliability Reqmts

RPM can readily be used to tradeoff whether to grow an existing equipment otherwise meeting requirements to also meet the specified MTBF or to select a new development. A mature existing equipment would have an alpha of about 0.15 and a new development would have an alpha of about 0.5. As shown, in the example, the required MTBF is 1,000 hr, the existing equipment has an initial MTBF of 600 hr and the new equipment has an initial MTBF of 150 hr. The new

equipment and existing equipment, respectively, require 5,000 and 2,000 testing hours to achieve the required MTBF. If, for example, program timing is such that the testing has to be completed in 3,000 hr then two new development equipments must be tested in parallel. The cost of the two testing programs and two reliability programs along with other recurring and non-recurring costs may be now compared and evaluated for selection of the best candidate.

RPM APPLICATION EXAMPLE FOR SPACE SHUTTLE

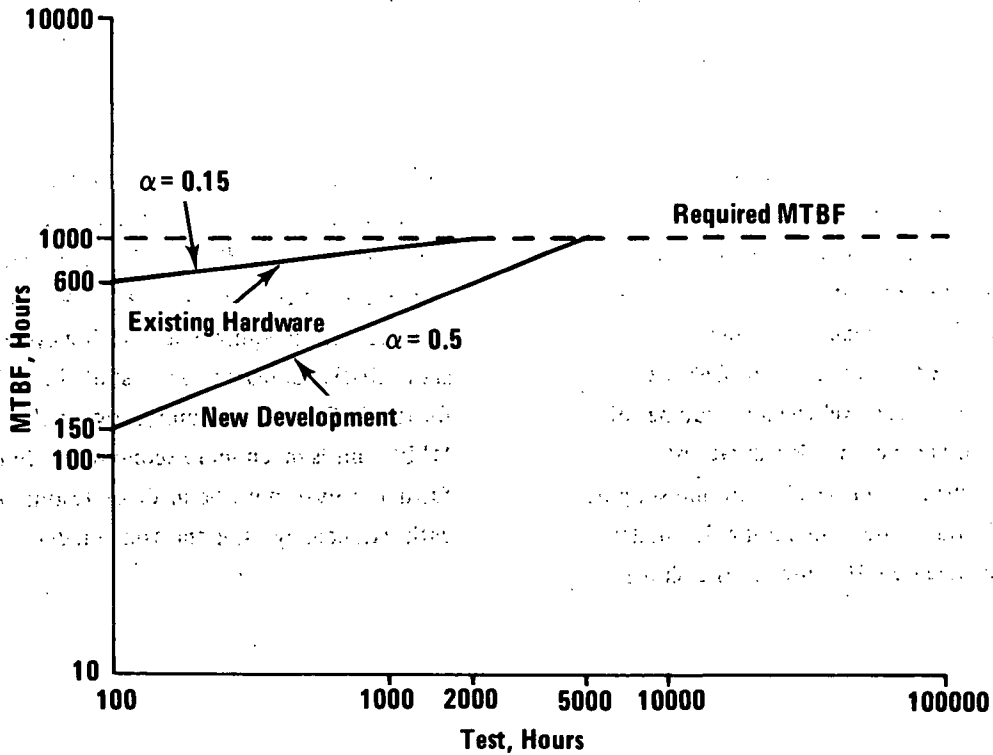

GE has developed a Life Cycle Cost model for Shuttle avionics cost comparison for any two candidates taking into consideration such factors as non-recurring development costs, unit recurring production cost, MTBF, redundancy, maintenance cost, mission abort probability, vehicle loss probability, cost of mission abort, cost of vehicle loss, number of missions, number of vehicles, mission duration/ phases, weight penalty, power penalty, ground support cost, etc. This illustrates the results using the model to compare two candidate IMU's used in the Shuttle

without redundancy. Candidate 1 has an MTBF of 3,000 hr and a hardware/software cost of \$3M. Candidate 2 has an MTBF of 5,000 hr and a hardware/software cost of \$6M. After 445 missions the 3,000 hr MTBF equipment has a life cycle cost of about \$80M compared to a cost of about \$50M for the 5,000 hr MTBF unit, showing that the higher MTBF unit is much more economical. In this example further analysis must be made on testing candidates with redundancy using the same model.

LIFE CYCLE COST-RELIABILITY EXAMPLE

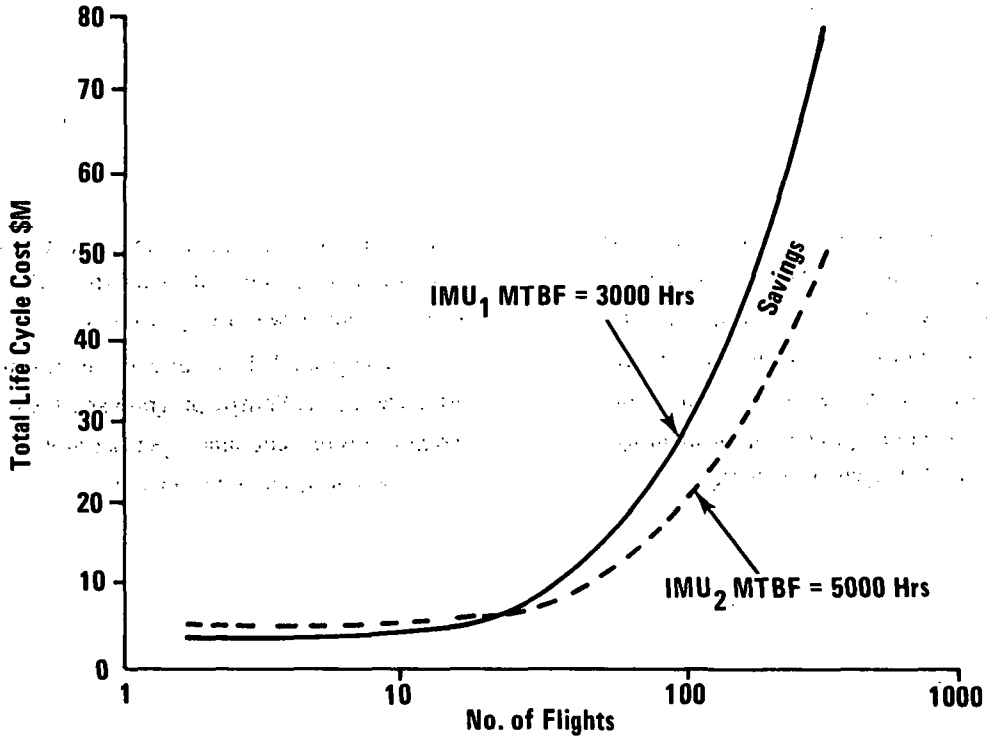

General Electric as a Grumman team member has concluded in its studies that redundancy requirements should be determined by functional criticality in combination with LRU reliability assessment. In addition, once LRU candidates are identified, it is recommended that an early well-planned test program implementing the Reliability Program Management technique can

significantly improve the reliability and hence the operational availability of each LRU and result in lower risk and lower life cycle costs.

New ground checkout equipment is most cost effective for the Shuttle program and the costs to develop this test equipment is insensitive to the on-board avionic systems considered.

AVIONICS STUDY LESSONS LEARNED

- **LRU Criticality Assignment Reduces Redundancy and Testing Requirements**
- **UTE for GSS is Cost Effective**
- **UTE Insensitive to Variations in Configurations**
- **Reliability Program Management Techniques Can:**
 - **Enhance Equipment Tradeoffs**
 - **Reduce Risk**
 - **Increase Schedule Confidence**

RECOMMENDED FOLLOW-ON EFFORT

- **Confirm Major Architecture Decisions**
 - **Dedicated Flight Control Computer**
 - **Digital Flight Control Computer**
 - **Fly-By-Wire**
 - **G&N Function in Central Computer**
 - **Dedicated Flight Instruments**
 - **Further Study to Determine Technical Possibilities vs Over-All Program Cost for Development of Common Use RAU**
 - **Further Study to Determine Best RF Transmission Means/Bands for DFI Due to Quantity of Data to Be Transmitted**
 - **Phased Growth Program (FHF, Mk I, Mk II)**
 - **Crew Size**
 - **SST Flight Control Actuators**
 - **Review Candidate Equipments With NASA RQ&A**
- **Define Mission Reqmts to Ensure that the System Designed Will Satisfy the Ultimate Reqmts**
- **Define the Avionics System to the Next Level of Detail (Prel Equipment Procurement Specs, Interface Control Documents, etc)**

RECOMMENDED FOLLOW-ON EFFORT (CONT)

- **Conduct Tech Tradeoff Studies in the Following Areas:**
 - Auto-Landing Aids
 - Software Sizing
 - Redundancy Levels
 - Extent of Cross Strapping
 - Ground/Flight Interface Reqmts
 - Mk I On-Board vs Ground Checkout
- **Conduct In-Depth Reviews of the Suitability of the Low Cost Equipment Candidates for Space Shuttle Application. Define and Cost Delta RQ&A**
- **Study the Reqmt for Unmanned Vertical Flight Test**
- **Define Safety & Mission Success Reqmts to Next Level of Depth & Verify Redundancy Meets these Reqmts**

