



THE  
*CR 115469*  
JOHNS HOPKINS  
UNIVERSITY

DEPARTMENT

OF

PHYSICS

(NASA-CR-115469) ROCKET FLIGHT PERFORMANCE  
OF A PREPROTOTYPE APOLLO 17 UV SPECTROMETER  
S-169 W.G. Fastie (Johns Hopkins Univ.)  
3 Jul. 1971 97 p

*Get DRA*

872-20385

CTCL 148

63/14

Unclass

21431

SPECIAL REPORT

NASA/MSC Contract NAS 9-11528

Task I. Principal Investigator Services

ROCKET FLIGHT PERFORMANCE OF  
A PREPROTOTYPE APOLLO 17  
UV SPECTROMETER - S169

Submitted by

Wm. G. Fastie  
Principal Investigator



Baltimore, Maryland 21218

July 3, 1971

**SPECIAL REPORT**

**ROCKET FLIGHT PERFORMANCE OF A  
PREPROTOTYPE APOLLO 17 UV SPECTROMETER - S-169**

Submitted by

**Wm. G. Fastie  
Principal Investigator**

**The Johns Hopkins University  
Department of Physics  
Baltimore, Maryland 21218**

**NASA/MSC Contract NAS 9-11528**

**Task I - Principal Investigator Services**

**July 3, 1971**

## TABLE OF CONTENTS

I.	Introduction	1
II.	Description of Preprototype Spectrometer	2
III.	Preflight Calibration	4
IV.	Preflight Optical Adjustments	6
V.	Wavelength Adjustment	10
VI.	Vibration Checks	14
VII.	Baffle Scattering Checks	14
VIII.	Launch Preparation	15
IX.	Flight Results	17
X.	Recommendations	22
Appendix A. Sketches of the Mechanical-Optical System		
Appendix B. Photographs of Instrument Parts, Subassemblies and Rocket Installation		
Appendix C. Aerobee 350 Flight Acceptance Vibration Specifications		

## I. Introduction

The purpose of this special report is to describe in detail the design, construction, testing, calibration, flight performance and flight data of an Ebert ultraviolet spectrometer which is an accurate representation of the conceptual design of the Apollo 17 UV spectrometer. The instrument was flown in an Aerobee 350 rocket from Wallops Island, Va., at 7:10 p. m. EDT on June 10, 1971 to an altitude of 328 km with a solar elevation angle of about  $11^{\circ}$ . The funds to provide the instrumentation were part of a special supplement to NASA grant NGR-21-001-001 with Johns Hopkins University for which the writer is principal investigator.

This report is presented in advance of the critical design review of the Apollo 17 UVS for the purpose of demonstrating the soundness of the optical-mechanical-electronic designs of the Apollo 17 UVS which are to be presented at the CDR.

In particular, the rocket experiment has provided the following technical information which will be invaluable to the Apollo 17 UVS experiment:

1. Laboratory and in-flight light scattering measurements with an entrance baffle substantially identical to the Apollo 17 UVS baffle.
2. Experimental proof that the novel exit slit mirrors will provide increased output signal with no loss of spectral resolution.
3. Experience with the unified slit plate assembly which includes the wavelength drive system, diffraction grating mount,

wavelength fiducial system, exit slit mirror assembly and detector electronics.

4. Demonstration that the Vacuum Optical Bench at Goddard Space Flight Center can provide a significant absolute calibration check point without modification to the VOB.

5. Experimental proof that the proposed pulse counting electronic circuitry provides spectral information limited only by statistical fluctuations in the UV photon flux.

6. Experimental proof that the proposed sensitivity of 50 photoelectrons per second per Rayleigh for the Apollo 17 UVS can be achieved.

7. Flight data at the top of the earth's atmosphere showing weak emission features in the intensity range anticipated from the Apollo 17 experiment. This information will be extremely useful in planning the real time data presentation and in programming lunar data for scientific analysis.

## II. Description of Preprototype Spectrometer

The conceptual design of the optical-mechanical system is shown in Fig. 1 in an exploded isometric sketch. Fig. 1 was included in our response to the RFP as an end product of the preliminary design study contract (NAS 9-10292) and engineering design study contract (NAS 9-11288) which preceded the current combined hardware and principal investigator services contract. A block diagram of the electronic

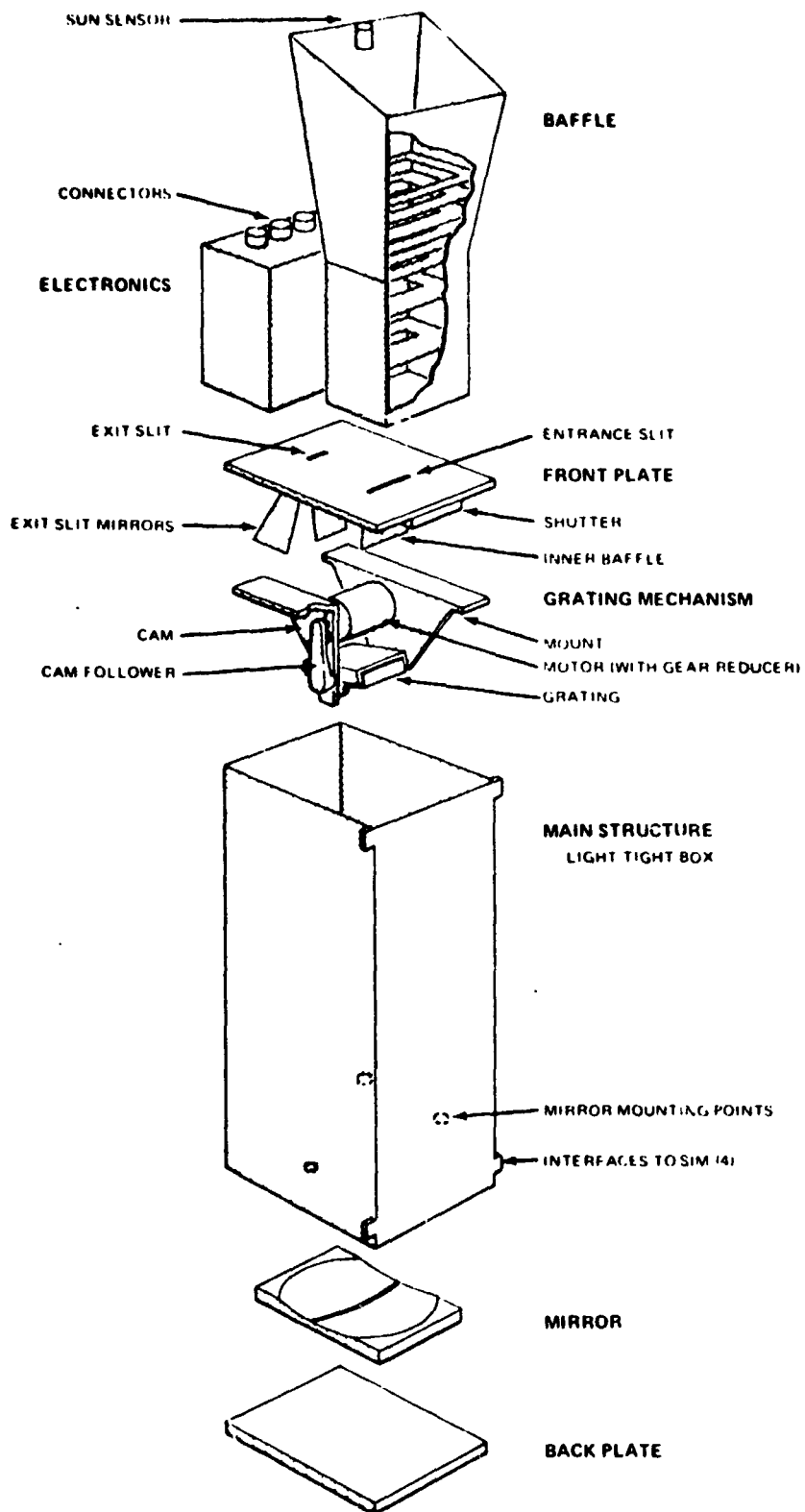

Fig. 1 UVS EXPLODED VIEW

circuitry is shown in Fig. 2 as it existed at the end of the preliminary studies. The preprototype instrument was designed and constructed to conform to the above design criteria.

Appendix A is a set of sketches of the mechanical-optical system as it was constructed. Appendix B is a set of photographs of the instrument parts, subassemblies and rocket installation.

For purposes of comparison, the major differences between the preprototype spectrometer and the design to be presented at the critical design review are as follows:

1. The main housing was a magnesium casting which was cut out in places to accommodate the Apollo UVS slit geometry. It interfaced with the rocket at four points at the Ebert mirror end of the housing.
2. The Ebert mirror was slightly undersize.
3. The cam drive motor was a commercial Weston synchro-servo motor requiring 3 watts.
4. A standard grating blank 110 mm x 110 mm x 16 mm thick was used. The grating was from the only existing B and L master which will be used as a backup master for the Apollo UVS in the event B and L cannot produce a satisfactory new master.
5. No external thermal insulation was used.
6. The EMR 542G photomultiplier tube had a lithium fluoride window instead of the magnesium fluoride window specified for Apollo.

The high voltage power supply was a separate unit mounted next to the PM tube rather than integrated with the PM tube as is proposed for the Apollo 17 instruments.

7. The electronic units were standard components purchased from SpaCom Electronics Company but operated in a manner substantially identical to the Apollo 17 electronic system shown in Fig. 2, as proposed by Applied Physics Laboratory (Mr. G. Donald Wagner). The system output was made compatible with Aerobee FM-FM telemetry, but was tape recorded in a format which will make it possible to produce a magnetic tape identical to the Apollo data tapes. A block diagram of the preprototype electronic system is shown in Fig. 3. Figs. 3a to 3d show detailed circuitry for the electronic components shown in Fig. 3.

The regulated low voltage power supplies to operate the electronic system were also supplied by SpaCom. These supplies were in common use with other experiments aboard the rocket.

### III. Preflight Calibration

The following optical tests were made on the mirrors, grating and photomultiplier tube:

1. Two Ebert mirrors were coated with Al-MgF at the Goddard Space Flight Center coating facility (Dr. John Magnus) and measured by them to have reflectivity in the range 80 to 85% at 1216 A. These values were confirmed by measurements in our laboratory.



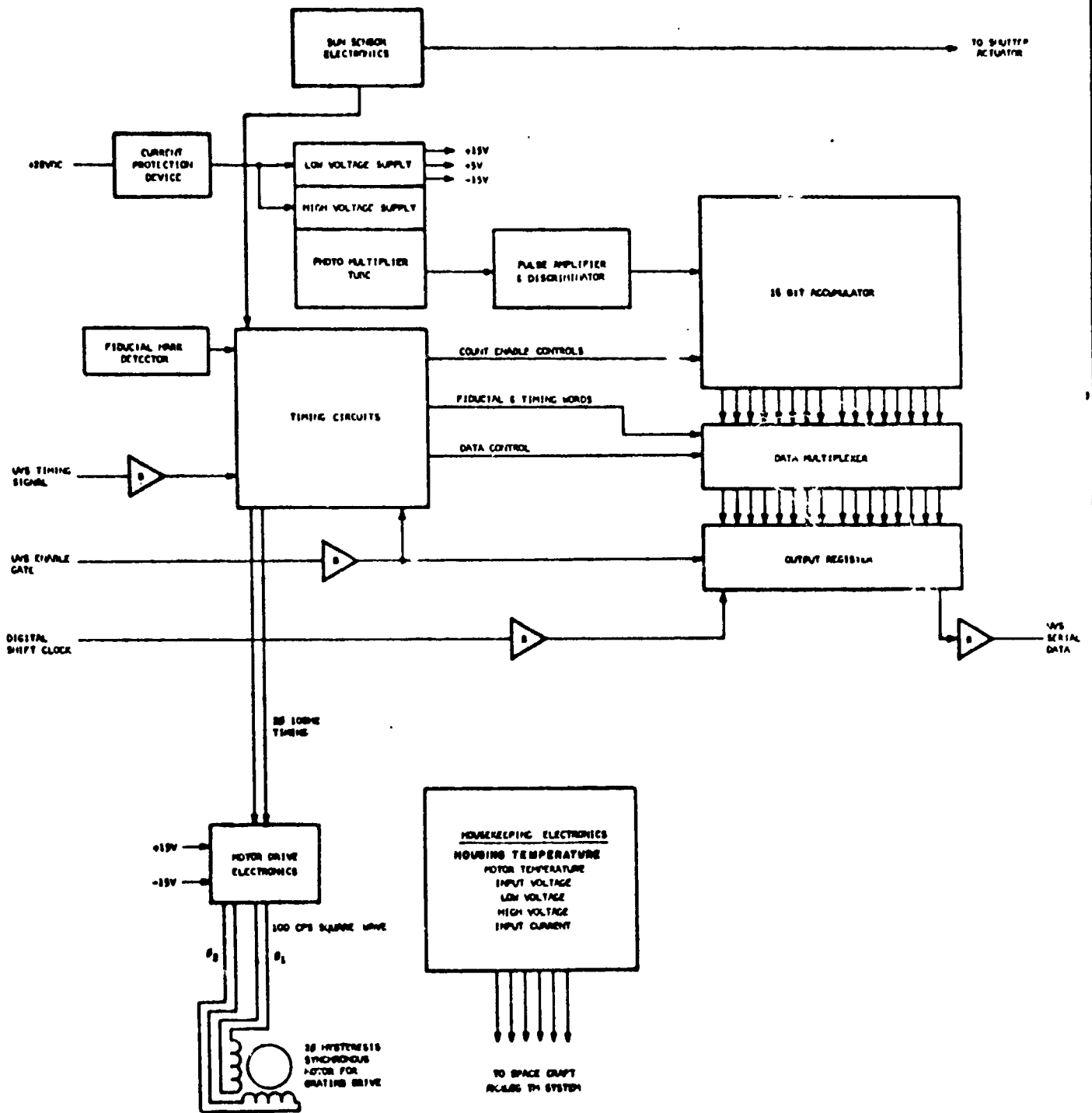

Fig. 2 BLOCK DIAGRAM FOR UV SPECTROMETER

17.11  
3 Jun 71  
MDC

AEROBEE 17.11

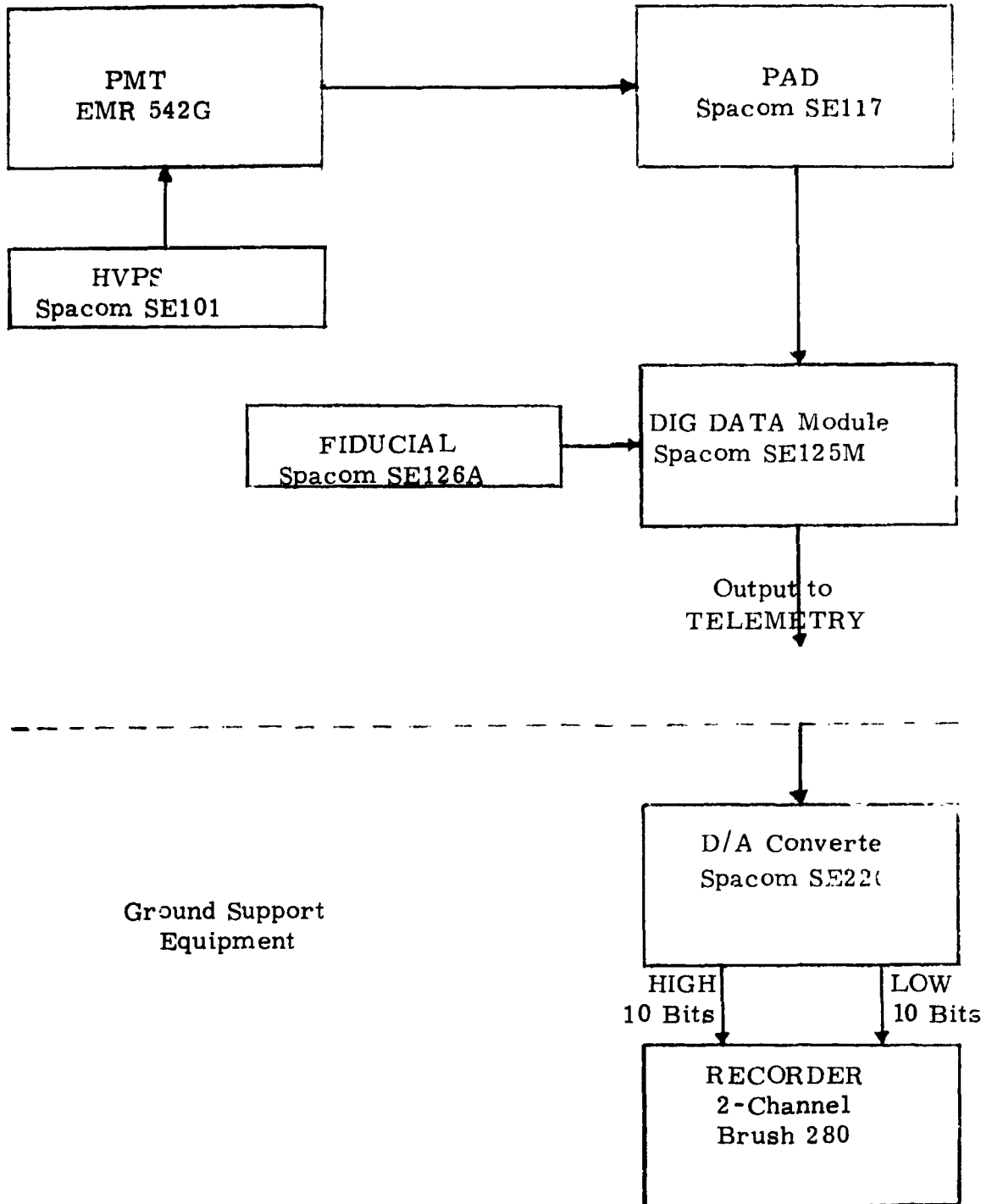
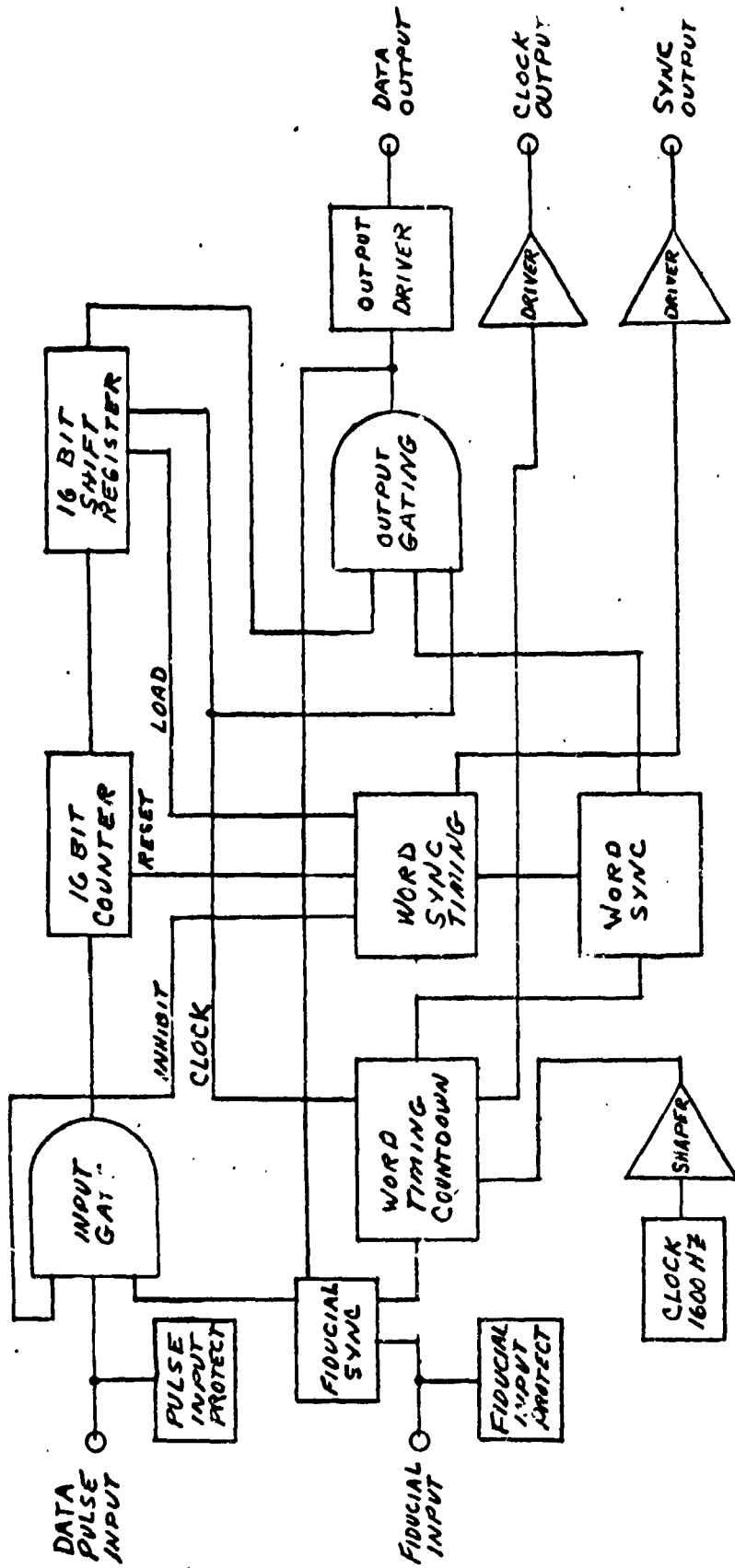

Fig. 3. Preprototype Electronic System



SPACOM ELECTRONICS  
 266 No. Mobil Suite III  
 Camarillo, Calif. 93010

OWN Pat 6-24-71 CKD 2-5/25/74 APPD

SE 125 A1

16 BIT DIGITAL DATA SYSTEM

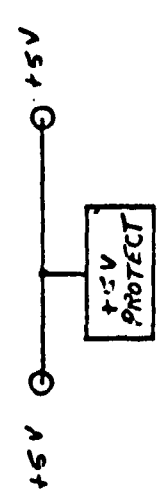
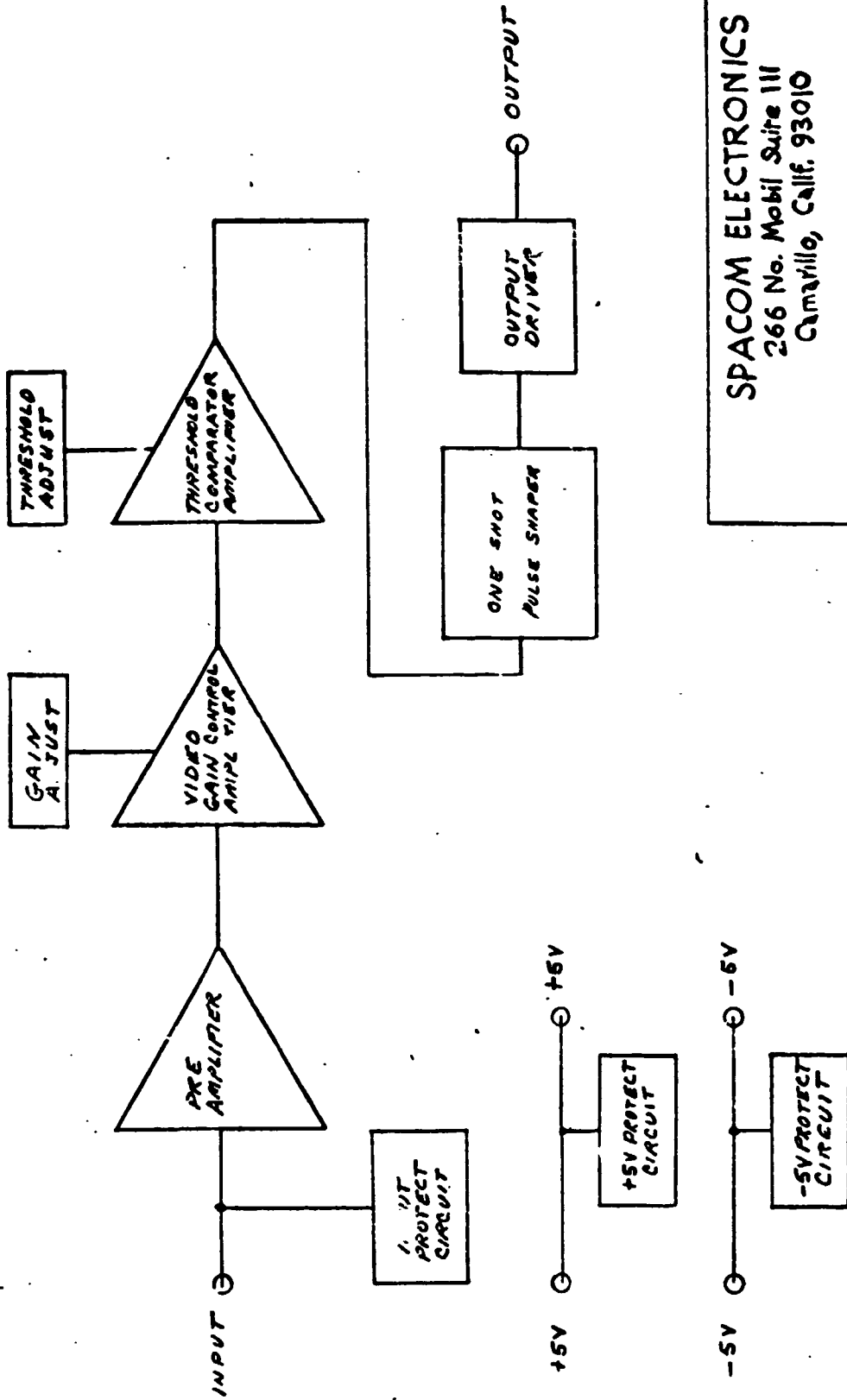
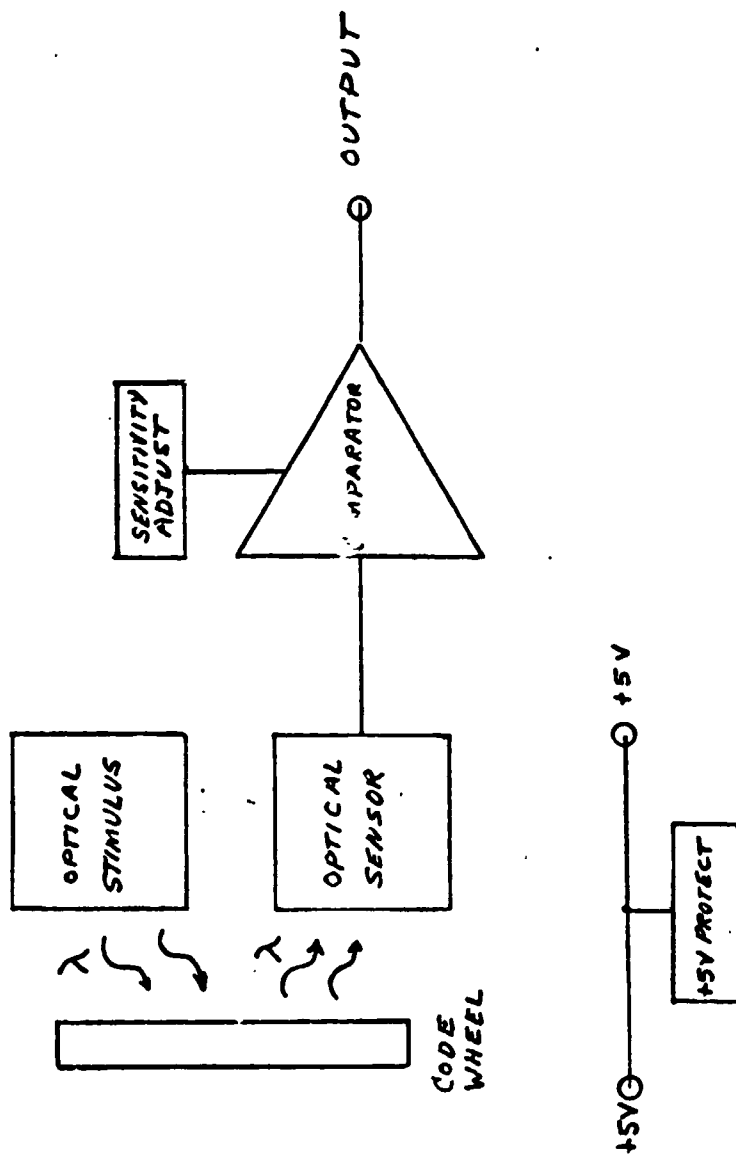

Fig. 3a



SPACOM ELECTRONICS	
266 No. Mobil Suite III	
Camarillo, Calif. 93010	
DWN 9/11 6-24-71	CKO 526/35/71 APP9
SE 117	
BLOCK DIAGRAM	
PULSE AMPLIFIER DISCRIMINATOR	
± 5 V SUPPLY	

Fig. 3b



SPACOM ELECTRONICS	
266 No. Mobil Suite III	
Camarillo, Calif. 93010	
DWN Rev 6-24-71	CMD 52-6/5/71 APPD
SE 126A	
BLOCK DIAGRAM	
OPTICAL FIDUCIAL READER	

Fig. 3c

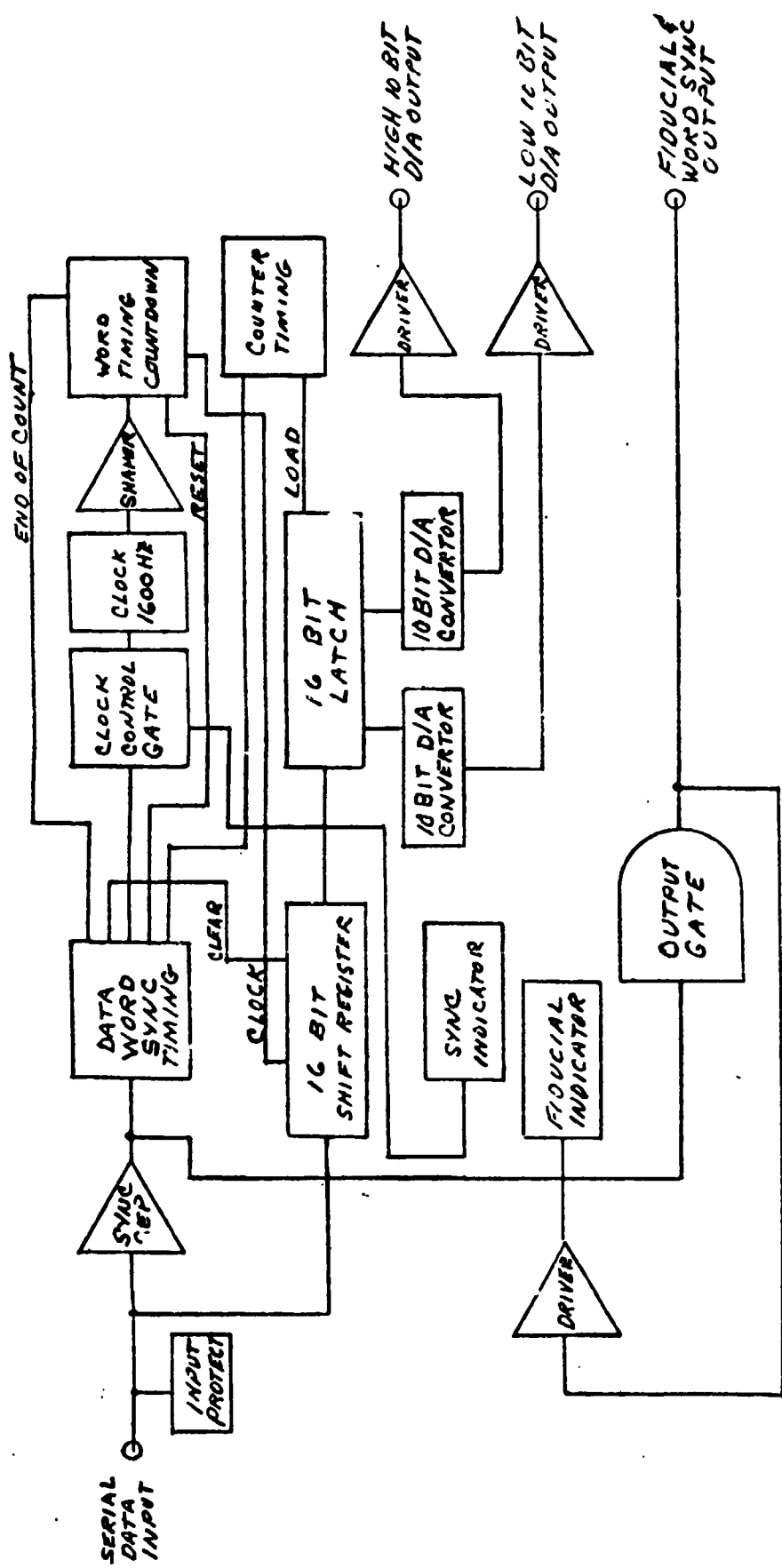

+ 5 VOLT  
POWER SUPPLY

+ 15 VOLT  
POWER SUPPLY

- 15 VOLT  
POWER SUPPLY

SPACOM ELECTRONICS 266 No. Mobil Suite III Camarillo, Calif. 93010	
DWN 2m 6-25-71 CKDC 6/25/71 APPD	SE 226
BLOCK DIAGRAM DIGITAL CONVERSION EQUIPMENT	

Fig. 3d

2. The B and L diffraction grating was measured in our laboratory and found to have degraded in reflectivity (it had been previously used in our research program). It was over-coated with Al-MgF at GSFC. When remeasured at our laboratory it exhibited close to the reflectivity which was measured when it was originally acquired from B and L.

3. The exit slit mirrors were coated with Al by GSFC. On the recommendation of GSFC no overcoating was applied to these mirrors (which are used at high angles of incidence) in order to avoid optical interference effects. The mirrors were measured at GSFC to have greater than 70% reflectivity in our spectral range. This measurement was confirmed in our laboratory.

4. The EMR 542G photomultiplier tube was checked for quantum efficiency at three wavelengths (1608, 1435 and 1216 A) and found to meet manufacturer's specs but had only 60% of the Q. E. specified for the Apollo UVS.

5. On the basis of the above measurements the instrument sensitivity was found to be about 27 photoelectrons/sec per Rayleigh at 1216 A and 18 pe/sec/Ray at 1608 A.

6. The preprototype calibration was independently checked at these two wavelengths in the Vacuum Optical Bench at Goddard Space Flight Center (Mr. James Diggins). There was only about 10% difference between our laboratory calibration and the VOB check.

7. The VOB calibration also demonstrated that the projected false count rate of 1 pulse per second for the Apollo 17 experiment can be achieved. (This limit is imposed by thermal electrons from the photocathode of the PM tube.) In the VOB the electronics were well shielded from pickup by the vacuum chamber walls, the regulated voltage for the electronics was provided by highly stabilized laboratory supplies and the instrument output was hard wired to the data acquisition system. Thus telemetry RFI, power supply noise and external radiation sources were avoided. Under these conditions the false count level was less than 1 count every two seconds.

#### IV. Preflight Optical Adjustments

The Ebert mirror and grating optical adjustments required involve rotation of the grating blank and tilting of the grating blank in plane so that the grating rulings are parallel to the axis of rotation of the grating shaft. The Ebert mirror must be adjusted so that the center part of the slits is in the focal plane and so that the center of curvature of the mirror, the horizontal center line of the grating (a line perpendicular to the grating rulings) and the center point of the mirror are on the same line (this line must pass very close to the center point of the grating). These adjustments are independent and can be made with auxiliary optical components. These adjustments can also be made within the instrument with the use of a light source



and a low power microscope. The latter was the method employed on the preprototype spectrometer.

The following optical adjustments were made to the preprototype UVS. They are discussed in detail here because all of the mechanical-optical adjustment means are substantially identical to those provided for the Apollo UVS and all of the adjustment procedures described herein must be made on the Apollo UVS either within the instrument itself or with auxiliary optical fixtures.

1. The slits, grating, and Ebert mirrors were installed. The entrance slit was illuminated with a Hg pen-lamp and a thin wire (20 mil dia.) was placed across the exact center of the slits (parallel to the 2 mm dimension). The grating was rotated so that the central order and the positive and negative first orders of the Hg 4358 line could be observed at the exit slit through a shop microscope. The deviation of the three images of the entrance slit wire shadow from the exit slit wire was noted. The slit plate assembly, which includes the grating mount, was then removed from the main assembly and the grating blank adjusting screws were reset by the indicated amount. The instrument was reassembled and the optical check was repeated. This process was repeated until the positive and negative orders were seen to be equidistant from the center of the exit slit and to both be above or below the center.

2. A portion of the entrance slit jaw image was observed at the exit slit through the shop microscope with the grating set in the central order. The axial distance between this image and the center portion of the exit slit was measured.

3. The Ebert mirror was removed and the three nylon-tipped pins which determine the mirror position were replaced by new pins whose lengths were calculated to correct the focal error and to center the entrance slit image. The Ebert mirror was then replaced.

4. Steps 1, 2 and 3 above were repeated to refine the final adjustment. The second cycle produced an adequate optical adjustment for the center section of the slits.

5. The images in the central order of the grating of the top and bottom sections of the entrance slit were observed on the shop microscope. The slit plate assembly, which includes the exit slit mirror, was removed and the planes of the exit slit mirrors were adjusted by an appropriate amount by means of changing the length of the three nylon stops that position the mirror plane. The instrument was re-assembled and the adjustment checked. It was found that the first attempt provided adequate correction of the images, which correction is discussed below.

It is a property of grating spectrometers that the spectral image of a straight entrance slit produces a curved image. The spectral error thus produced is given by the equation

$$d\lambda = \lambda \frac{L^2}{F^2}$$

where

$d\lambda$  is the wavelength error

$\lambda$  is the wavelength

$L$  is the slit length

$F$  is the focal length

For the spectral region about 1400 Å the error is 2.5 Å. Since the spectral dispersion of the instrument is 5 Å per mm, this error amounts to 0.5 mm and requires that the images of the ends of the slit in the central order be displaced 0.5 mm so that in the spectral region 1175 to 1675 Å the curvature error will be minimized. This correction was applied to the preprototype instrument by adjusting the slit mirrors so that the reflected images of the ends of the slit in the central order were displaced  $\frac{1}{2}$  mm toward the center line of the instrument.

6. The mirror and the grating had been painted with flat black paint to represent the mirror and grating baffles designed for the Apollo instrument. The grating was visually observed in central order light by placing the eye at the exit slit to determine that the Ebert mirror axis passed sufficiently close to the center of the grating; that is, it was observed that the grating was fully illuminated. This adjustment, if needed, involves modifying the length of the Ebert mirror pins so that the mirror is rotated about an axis perpendicular to the mirror axis

and parallel to the axis of rotation of the grating. It is our general experience that this adjustment need not be made because the manufacturing tolerances are sufficiently accurate.

7. The entrance baffle was installed and the observation described in 6 above was repeated to determine that the entrance baffle was properly aligned and not shadowing the grating. No adjustment was required. If an adjustment had been required, the length of the thermally insulating standoffs that interface the external entrance baffle and the slit plate would have been adjusted to realign the baffle. With the completion of the above procedures the instrument was light ready with the exception of the precise adjustment of wavelength which is described in the next section.

#### V. Wavelength Adjustment

The operating spectral range of the UVS is in a region which is not transmitted in air at atmospheric pressure. The adjustment described herein makes it possible to adjust for the operating range without the need for vacuum operation.

The wavelength scan system consists of a motor driven cam which interfaces with the grating shaft by a follower arm which has a pin which fits into the groove in the cam (Fig. 4). The grating shaft is designed so that a long arm can be attached to it external to the spectrometer housing and positioned so that lateral translation of the free

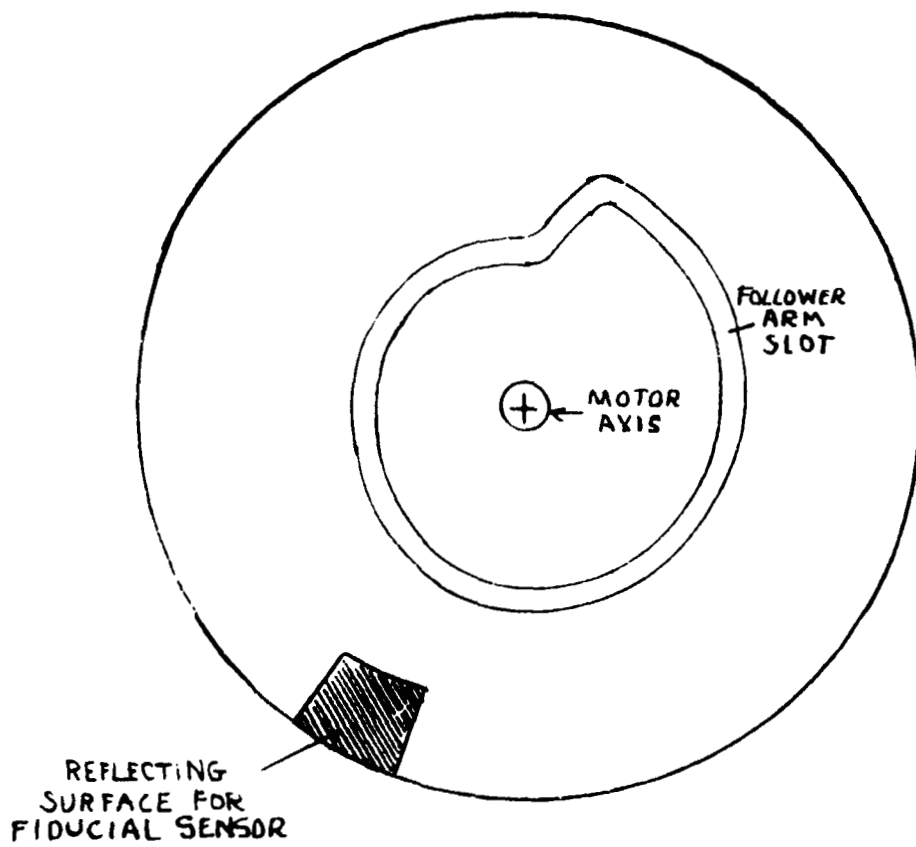

FIG 4- FLIGHT CAM  
SCALE= 2X

end of the arm rotates the grating. A micrometer caliper is fastened to the main spectrometer housing to measure the position of the arm as shown in Fig. 5. The micrometer was positioned so that its scale was perpendicular to the geometric axis of the main housing, i. e. the Ebert mirror axis.

The cam follower arm was released from the cam and the grating rotated to the central order as indicated by the output of the phototube which was recording the spectrum of a Hg pen-lamp. It should be noted that the position of the grating could be visibly observed through the indicated opening in the main housing to confirm that the central order was being observed. With the grating in the central order the arm was adjusted so that the plane of the micrometer blade passed through the center of the grating shaft as indicated by the dotted line in Fig. 5. The micrometer blade axis of the main housing was then repositioned until the 2537 Hg line was detected and the micrometer travel from zero wavelength to 2537 A noted. This distance is defined as  $X_{2537}$ .

The monochromator wavelength formula is

$$\lambda = 2a \sin \theta \cos \phi \quad (1)$$

where

$\lambda$  is the wavelength

$a$  is the grating space =  $\frac{1}{3.6}$  microns

$\theta$  is the angle between the grating normal and the bisector of the incident and diffracted beam

$\phi$  is the half angle between the incident and diffracted beam

The angle  $\theta$  is related to the length of the adjustment arm and the distance along the micrometer bar by the formula

$$\sin \theta = \frac{X}{L} \quad (2)$$

where  $X$  is the distance the micrometer blade moves from zero order and  $L$  is the length of the adjustment arm. Thus the wavelength is given by the formula

$$\lambda(A) = \frac{2 \times 10^4}{3.6} \frac{X}{L} \times .9875$$
$$\lambda(A) = 10 X \quad (\text{where } X \text{ is in mm}) \quad (3)$$

if the adjusting arm is 548.6 mm long and the value of  $\cos \phi$  (easily calculable from the known geometry of the mirror and exit slits) has the value .9875.

Thus, to set the wavelength to the start of the scan (1175 A) the adjusting arm should be moved 117.5 mm to an accuracy of about 0.2 mm ( $\pm 2 A$ ). The reason for using the 2537 line of the Hg lamp is to double check that the geometry is in accordance with equation (3).

With the micrometer set at  $X = 117$  mm, the cam was rotated to the starting position and the cam follower arm set in the cam groove locked to the grating shaft. The wavelength adjustment fixture was

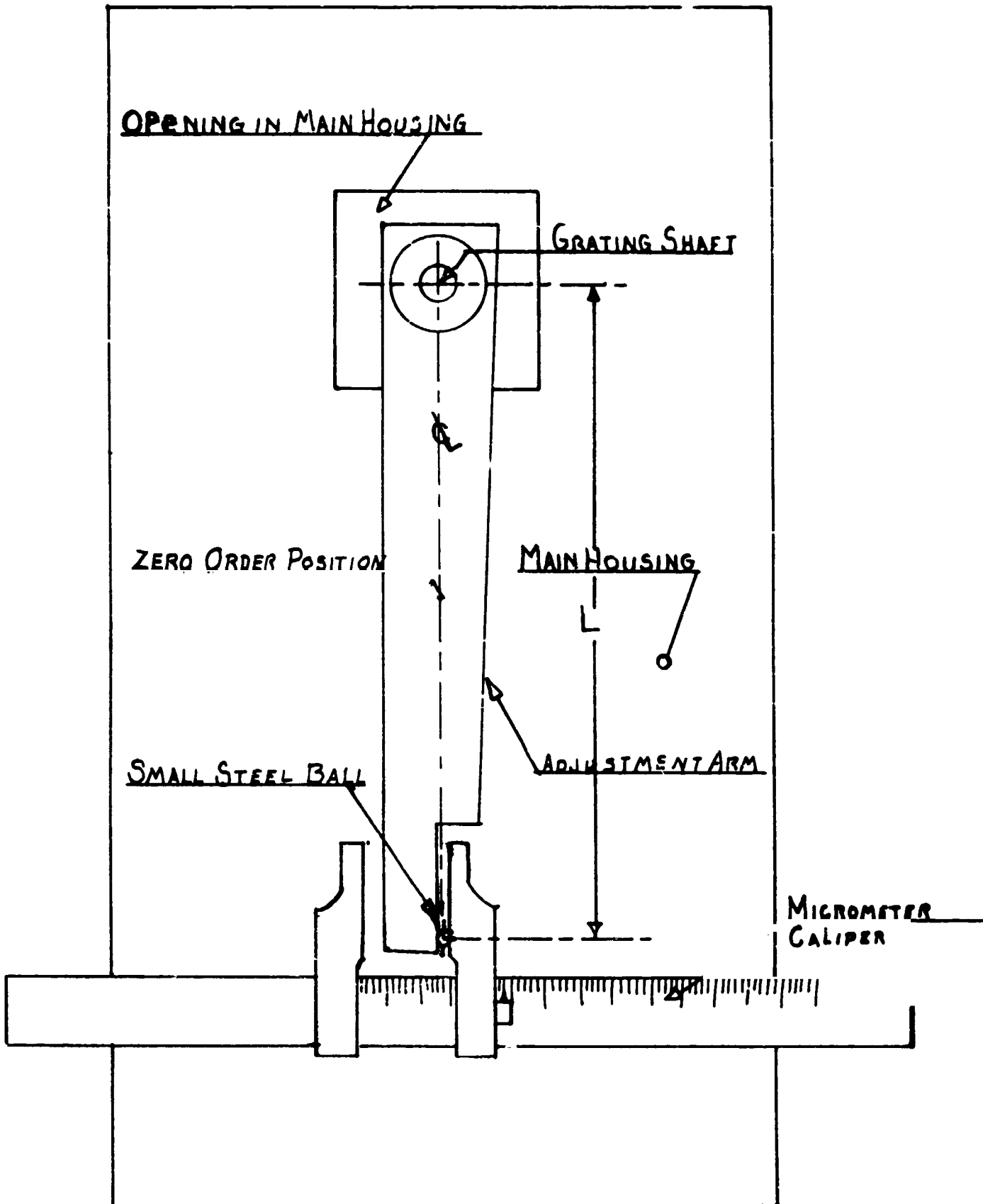

Fig.5 WAVE LENGTH ADJUSTMENT FIXTURE



removed and the cover plate for the opening in the main housing was reinstalled.

The spectrometer was then placed in a vacuum test chamber and the entrance slit illuminated with a UV source. A sample test spectrum thus obtained is shown in Fig. 6, and demonstrates that the adjustment procedure described above was successful. (For the purposes of the rocket experiment we wished to set the starting wavelength at 1170 Å instead of 1175 and achieved this setting to within 1 Å.)

As can be seen in the test spectrum the wavelength scan is not linear in time. The cam was designed so that about half of each scan period was devoted to scanning the regions 1195 to 1245 Å and 1445 to 1495 Å so that better statistics could be obtained on the most likely emission features in the lunar atmosphere, namely, the resonance line of atomic hydrogen at 1216 Å and the resonance line of xenon at 1470 Å. The cam, which was made in conformity with the cam program for the Apollo UVS, was designed to produce 1216 Å between the 17th and 18th  $\frac{1}{10}$  second counting period for a starting wavelength of 1170 Å. Fig. 6 shows that this setting was achieved. In this scan range successive counting periods change by about 1.75 Å.

The spectrum of Fig. 6 also demonstrates that the spectral resolution has a value of 10 Å, which is the geometrical limit set by the width of the slit. (Slit width 2 mm, spectral dispersion at the exit slit 5 Å/mm.)

The spectral check thus shows that the optical adjustments described in Section IV were properly executed.

#### VI. Vibration Checks

The spectrometer was mechanically interfaced with the rocket and given a standard Aerobee 350 three-axis flight acceptance vibration check. The specifications for this test are listed in Appendix C. There was no visible effect on the instrument. During the check visual observations indicated that the free end of the entrance slit baffle moved only very slightly with respect to the adjacent rocket skin, no more than  $\frac{1}{8}$  inch. The free end of the baffle was about 40 inches from the mechanical interface points with the rocket structure.

Just before and just after the shake test spectra were obtained in our vacuum facility. There was no observable change in the wavelength position or in the width of the spectral lines, confirming that the required optical rigidity had been achieved.

#### VII. Baffle Scattering Checks

To properly check the scattering properties of the external entrance slit baffle it would have been necessary to have a large evacuated dark room. As an alternative we checked the baffle at 2537 A where air is transparent and where scattering from the baffle surfaces can be expected to be at least as great as at shorter wavelengths.

The test was limited by light that was scattered by air. This Rayleigh scattering was so dominant that it was necessary to position the

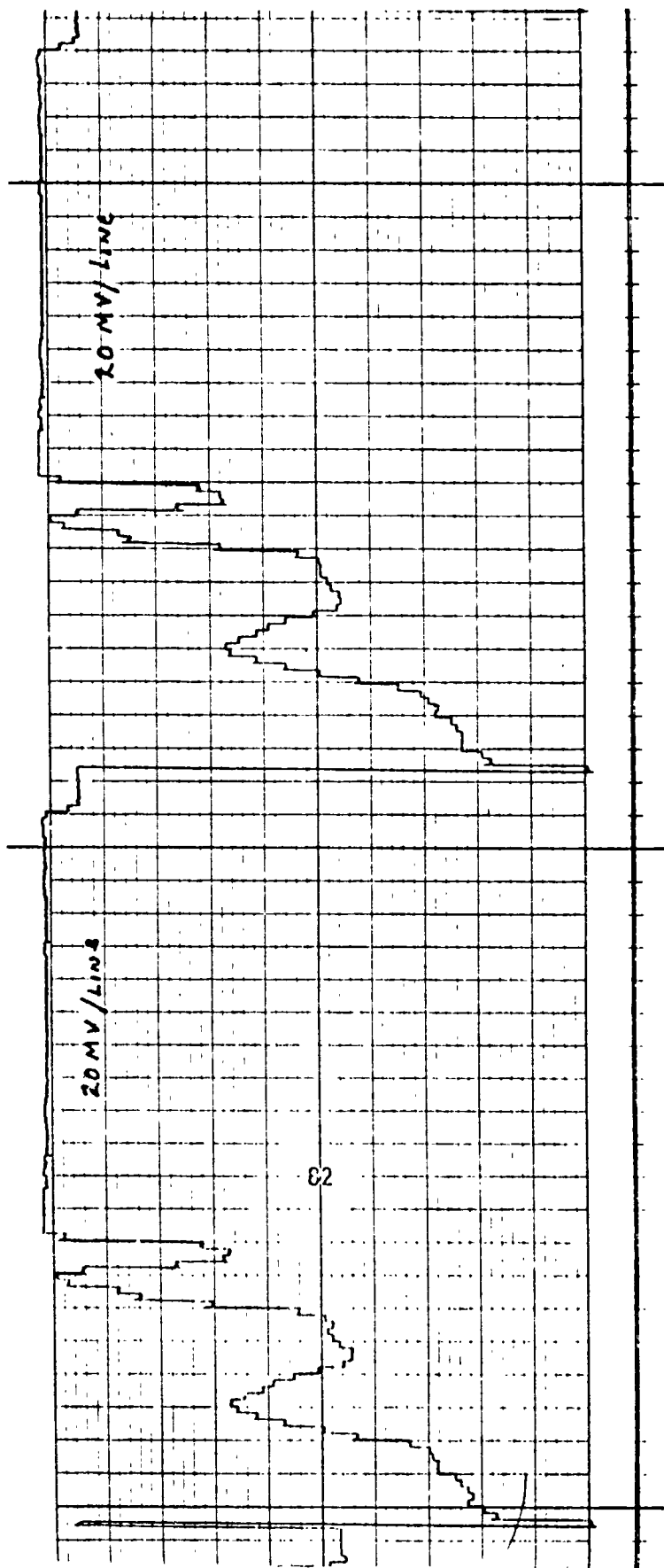

FIG 6  
VACUUM CHAMBER  
SAMPLE TEST SPECTRUM

light source so that the internal section of the triple sectioned baffle was half illuminated before scattering from the baffle itself was detectable.

Even under this extreme condition the baffle scattering ratio was about  $10^6$  and was certainly many orders of magnitude less than will obtain with the planned flight geometry and was thus estimated to be adequate for the mission.

#### VIII. Launch Preparation

The original launch date of June 3 was cancelled because of winds. During the preparation for a June 4 launch an acid spill in the Aerobee tower forced rescheduling for June 10, when the launch occurred.

All preparation of the payload at the launch site was conducted in the clean room located in the preparation area of the Aerobee launch facility. The instruments were installed in the payload portion of the rocket and the nose cone installed in the clean room. When this section of the rocket was removed from the clean room to be mated with the rest of the rocket and to conduct final horizontal checks, pure bone-dry water-pumped nitrogen was purged continuously through the payload section which was isolated from the remainder of the rocket by a pressure bulkhead. For installation in the tower, small leaks in the payload section were sealed with tape and nitrogen flow was continued after tower installation. The break in the nitrogen flow was less than 30 minutes.

During standby in the tower a plastic cover bag was placed over the nose cone and payload section, a rain tent was placed above the rocket (the tower is open to the weather) and the flow of dry nitrogen was increased to about 20 cu. ft. per hour.

The acid spill, which occurred at 2:00 p. m., amounted to 750 lbs. of red fuming nitric acid which did significant damage to the tower, particularly the electric circuitry, and required the tower top water deluge system to be operated for about 2 hours. Due to the loss of power, the rocket could not be removed from the tower until about 9:00 p. m. During this period the nitrogen was purged continuously at an increased rate of about 40 cu ft. /hr.

Visual inspection of the spectrometer in the clean room indicated no damage had occurred, at least no water had entered the payload section of the rocket. The spectrometer was returned to our laboratory at midnight and the next morning the Ebert mirror was removed from the main housing, placed in our vacuum checking facility and compared directly with a spare mirror with which it had previously been compared to about 1% accuracy. This test indicated that there had been no degradation of the optics. The Ebert mirror was replaced. The slit plate was also removed from the main housing to adjust the fiducial marker which had been behaving erratically during the field checks. The instrument was reassembled and placed in our vacuum facility for a wavelength check. The spectral scans thus obtained

were indistinguishable from that shown in Fig. 6 in wavelength position and in spectral resolution.

The above rather harrowing experience demonstrated two important points.

1. The conceptual design of the Apollo UVS is sufficiently rugged to permit disassembly for servicing or checking purposes without disturbing the wavelength setting or the spectral resolution. It demonstrates that the instrument can be transported in a station wagon a distance of 320 miles without degradation in the optical adjustment.

2. The precautions which were taken to protect the instrument from the environment were more than adequate. The seashore environment at Wallops Island is rugged and comparable to that at Cape Canaveral and both represent a danger to the UVS, but neither can compare to the conditions which the preprototype instrument survived.

## IX. Flight Results

### A. Preliminary Discussion

All of the flight objectives of the Aerobee 350 experiment as they related to the Apollo 17 UVS were fully achieved. Before outlining the results in detail, a limitation which was imposed by the earth's exosphere and an equipment limitation will be discussed.

Even at the peak of the flight, the earth's hydrogen corona was (as expected) a very large signal, of the order of five kiloRayleighs

and represented a constant grating illumination of about  $2 \times 10^6$  photons per second throughout the spectral scan. Because the grating scattering coefficient has a value of about  $10^{-3}$ , we thus anticipated an unavoidable background signal of about  $10^2$  photoelectrons/sec against which the in-flight baffle scattering properties could be determined. This limitation was partially overcome by planning the flight geometry so that scattering of solar UV from the baffle could be varied from zero (by having the solar angle at greater than  $90^\circ$  to the optical axis) to about 10 times as much as will be encountered in flight (by having the solar angle at less than  $70^\circ$ ). These variations were achieved in flight as a result of rocket precession. With the limitations imposed by Ly  $\alpha$  radiation scattered by the grating we would expect to evaluate the solar scattering performance of the baffle which would be representative of Apollo geometry.

For reasons which have not been analyzed, but which are probably due to a combination of sources, the in-flight performance of the electronic system under no light condition was an order of magnitude poorer than the system performance in the VOB reported at the end of Section III. The background noise of about 13 false pulses per second could have originated from telemetry RFI, RFI from other experiments, power supply noise, inherent or fed back from other instruments.

However, this performance did not affect the flight objectives because the Ly  $\alpha$  background scattered by the grating was dominant. It should also be noted that the flight was not a test of the specific electronic circuitry which has been designed for the Apollo 17 UVS but was a test of the conceptual design of that system employing commercially available components. The flight result does indicate that the precautions against electrical interference which are proposed for the Apollo 17 UVS electronic system are essential to avoid false backgrounds.

#### B. Flight Data

1. During the period after rocket burnout (55 seconds) and before nose cone ejection, a random count rate of about 13 pulses per second was observed. The source of this background has not been analyzed.

2. At peak altitude a wavelength independent background count of about 90 per second was observed. This signal is interpreted as being due to geocoronal Ly  $\alpha$  scattered by the diffraction grating.

3. During the 140 second period that the rocket was above 305 km, no variation in the background signal was observed. During this period the solar angle with respect to the optical axis varied from  $90^{\circ}$  to  $70^{\circ}$ ; thus we estimate that no significant solar signal scattered from the baffle surface will be encountered in the Apollo geometry. This estimate is based on the following calculation:



- a. The statistical fluctuation in the 90 photoelectron/second background was about 10 pe/sec.
- b. No variation in the background signal in excess of the statistical fluctuation was observed with variation in solar angle.
- c. The solar scattering geometry in the Aerobee 350 experiment is estimated to be worse than for the Apollo 17 worse case geometry. Thus, a solar scatter background of a few pe/sec is the largest to be expected under the worse conditions to be encountered in the lunar experiment.

Solar radiation scattered from the illuminated lunar surface will be an important possible source of radiation that the entrance baffle can scatter to the detector. Preliminary analysis indicates that during the most important portion of Mode I and Mode II operation, (i. e. with the spacecraft located on the dark side of the evening and dawn terminator and the optical axis of the UVS directed further into the shadow) the lunar surface scatter signal will be an order of magnitude smaller than the upper limit calculated in c above.

4. During the flight period when the Aerobee UVS was observing twilight ionospheric emissions, many weak emission bands of molecular nitrogen, which have not been previously reported were observed. A summation of the 3 brightest spectra with a preliminary brightness scale is shown in Fig. 7a, where time is linear on the x

Fig. 7a

Spectral Scans Aerobee 350 Flight  
Data (with Time Linear on x Axis)

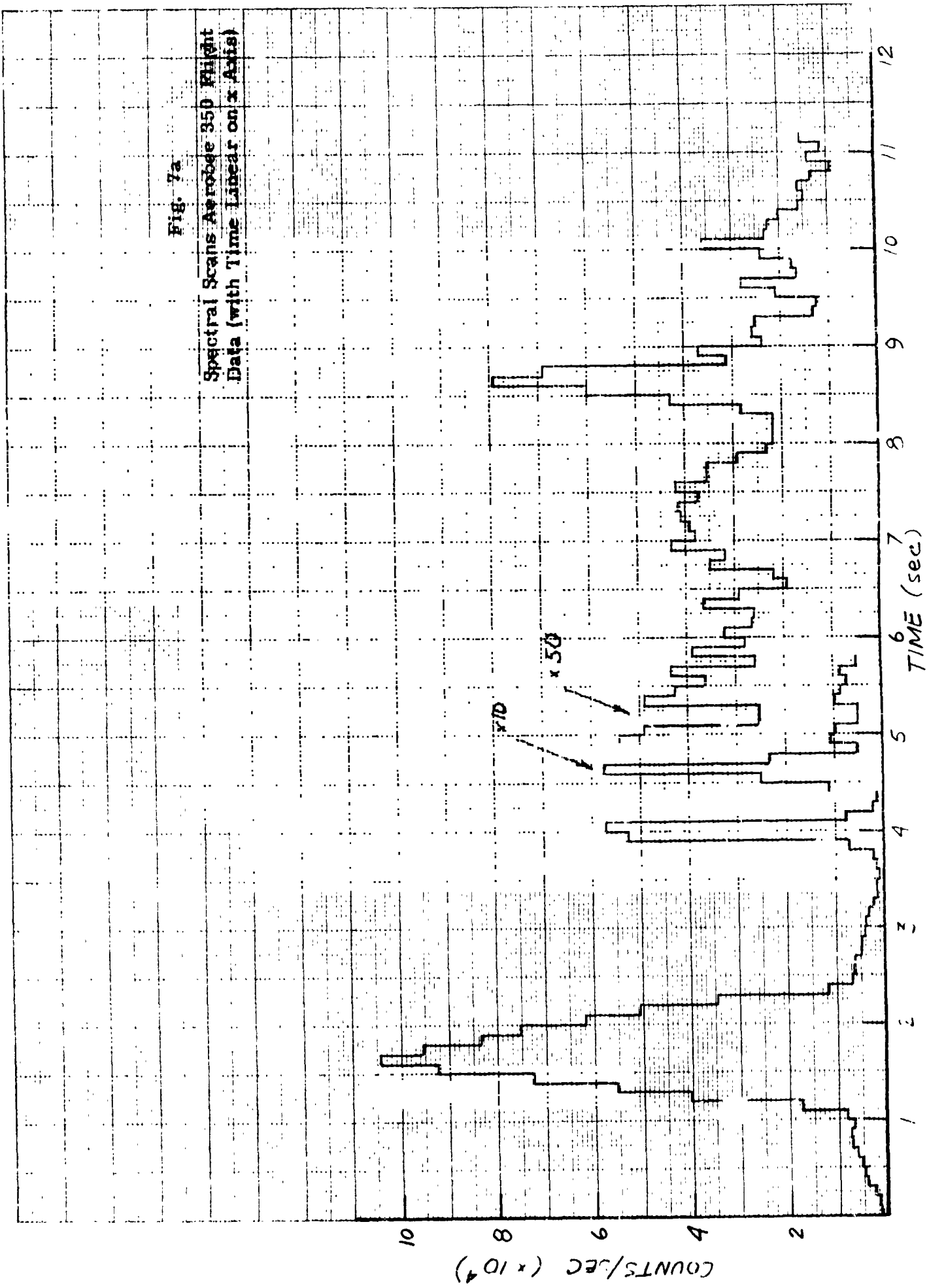

307  
KUPFFEL & BESSER CO

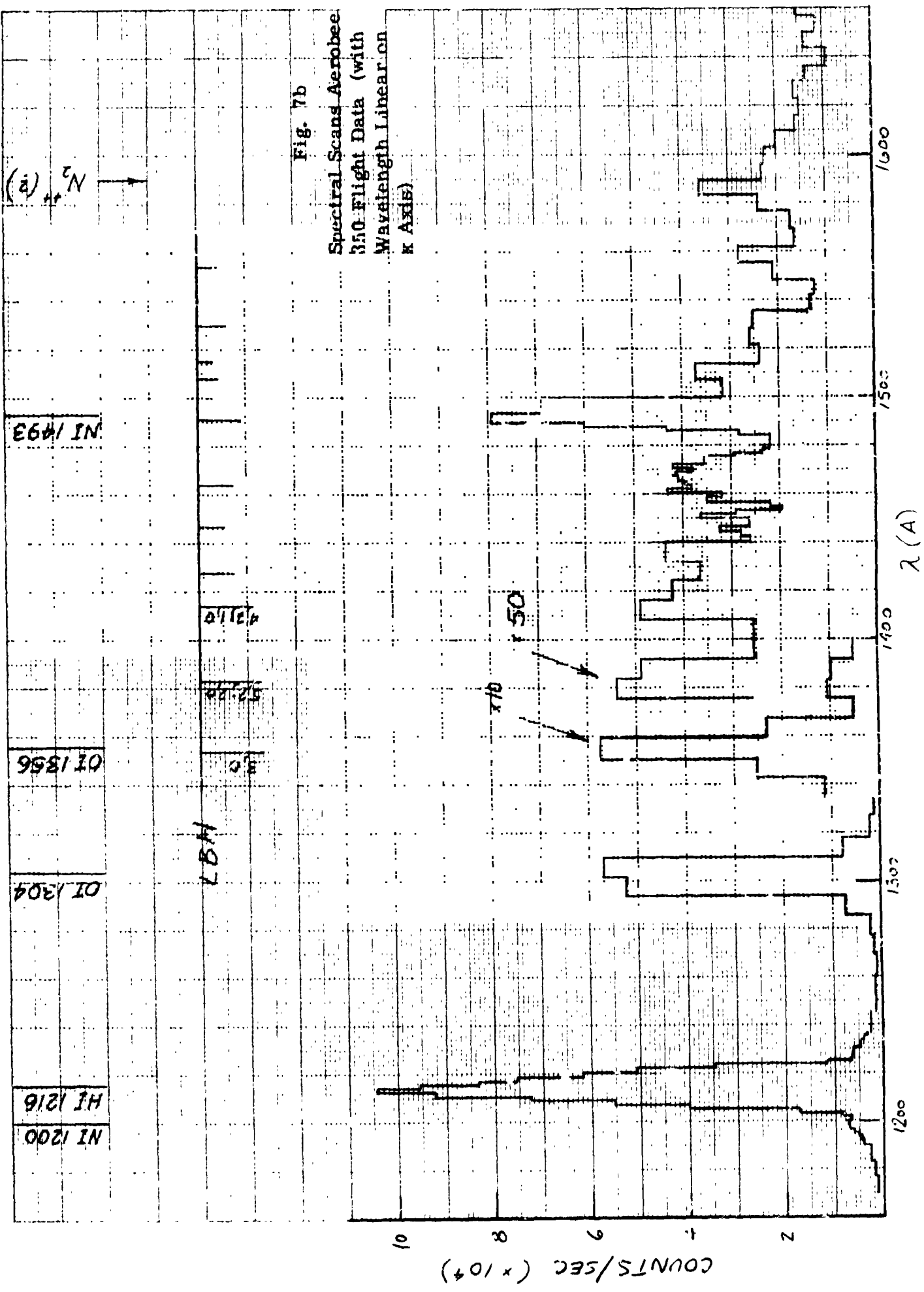

axis, and Fig. 7b, where wavelength is linear on the x axis. These spectra might be similar to the lunar atmospheric spectra obtained when the landing craft engines are burned.

These flight data demonstrate:

- a. That the high sensitivity observed in laboratory calibration was achieved in flight.
- b. That the spectral resolution is possibly slightly less than laboratory checks indicated would be achieved. The degradation is so small (less than 1 Å) that it cannot be positively evaluated but if real is not significant from the standpoint of the Apollo experiment.
- c. That the wavelength calibration was unchanged throughout the flight and was identical ( $\pm 1$  Å) to the preflight wavelength check. This can be observed in Fig. 7a where Ly  $\alpha$  peaks between the 17th and 18th 1/10 second data point after the fiducial mark. This flight spectrum is identical in wavelength, therefore, with the laboratory test spectrum shown in Fig. 6 and discussed in Section V.
- d. That the Aerobee 350 UVS continued to operate long after the beginning of the aerodynamic shock of reentry. Signal was finally lost due to telemetry failure, which occurred because of reentry shock. Thus, the instrument performed in a shock environment far more severe than the preflight environment checks imposed.

## X. Recommendations

Based on our experience with the Aerobee 350 UVS, it is the writer's firm conclusion that the engineering details of the proposed Apollo 17 UVS which will be presented at the critical design review will make it possible to produce an instrument which can fulfill the scientific mission which has been proposed. No flaw in electronics, optics, or mechanics has been detected in an instrument which is a remarkably close model and which has been subjected to realistic tests, realistic environments and which has made significant space measurement.

Preliminary analysis of the flight data suggests that small changes in the cam program might be advantageous from the standpoint of maximizing the Apollo 17 flight information. The Aerobee 350 cam scanned two 50 Å regions at about 17.5 Å/sec and the remaining 400 Å at about 64 Å/sec. The fast rate thus gave about three 0.1 sec measurements of a spectral feature (the full width of the bottom of the triangular signal being 20 Å as determined from flight data). We are currently considering decreasing the high speed scan rate slightly and increasing the slow speed somewhat. A detailed analysis is in progress. This change, if decided upon, will have a minor effect on the engineering program. It is recommended that the detailed cam design be delayed for a few weeks until the above analysis is complete.

**APPENDIX A**

**SKETCHES OF THE MECHANICAL-OPTICAL SYSTEM**

17-11 19 MAR 71 CHL

DATE	BY	REVISION RECORD	AUTH.	DR.	CL.

17.11  
19 MAR 71  
CHL

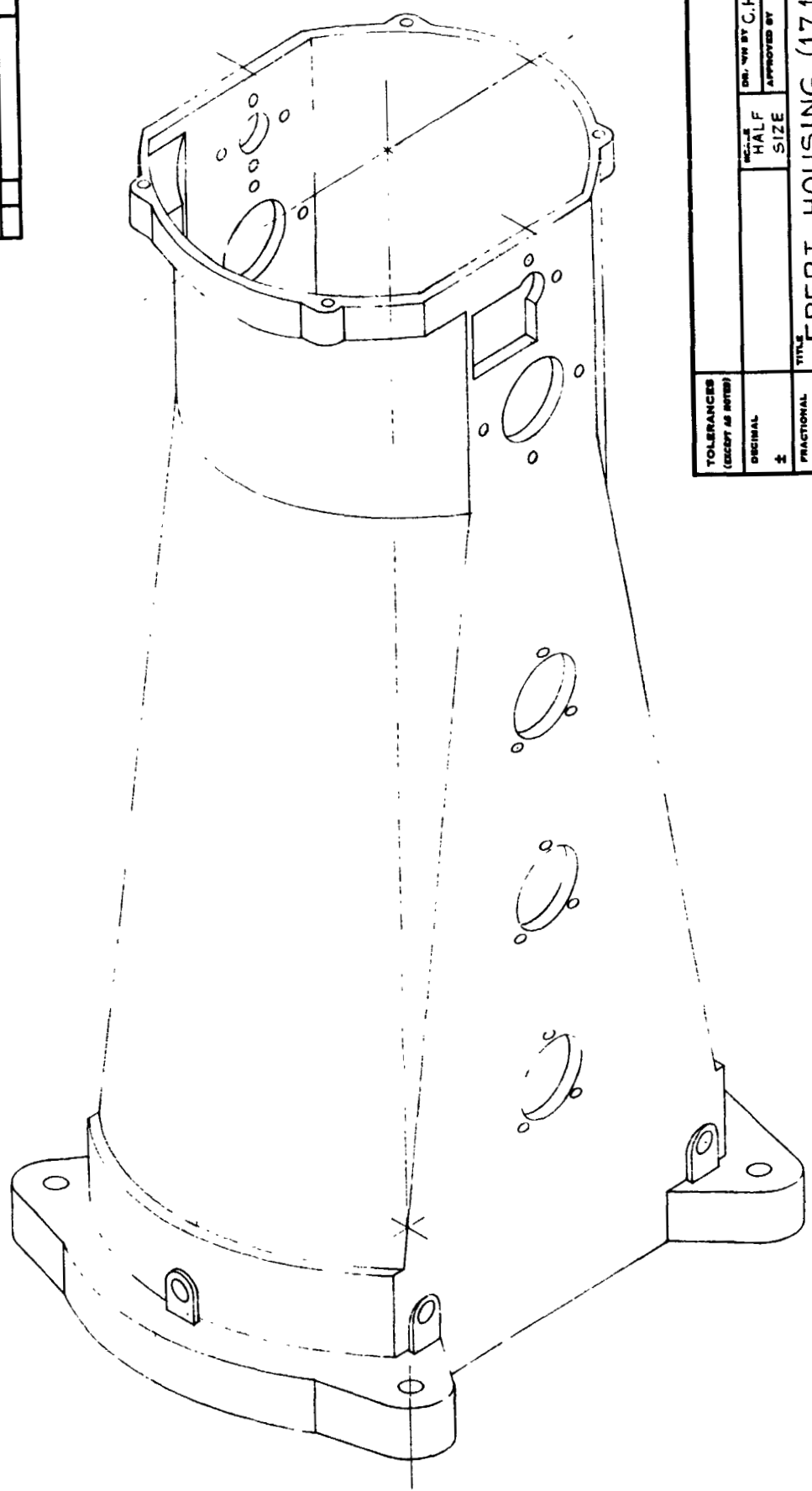

TOLERANCES (EXCEPT AS NOTED)		DRAWN BY C.H. LAKE	
ORIGINAL	±	SCALE	APPROVED BY
FRACTIONAL	±	HALF SIZE	
ANGULAR	±	TITLE EBERT HOUSING (17.11)	
		DATE	DRAWING NUMBER
		3/30/71	

17-11 19 MAR 71 CHL

# FOLDOUT FRAME (

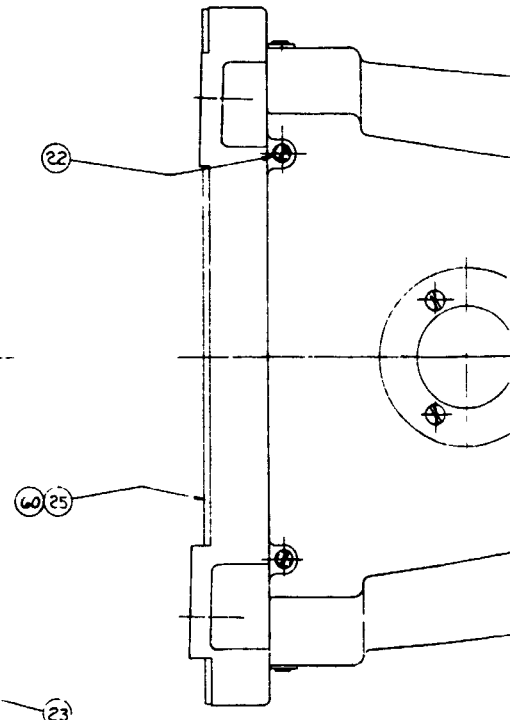
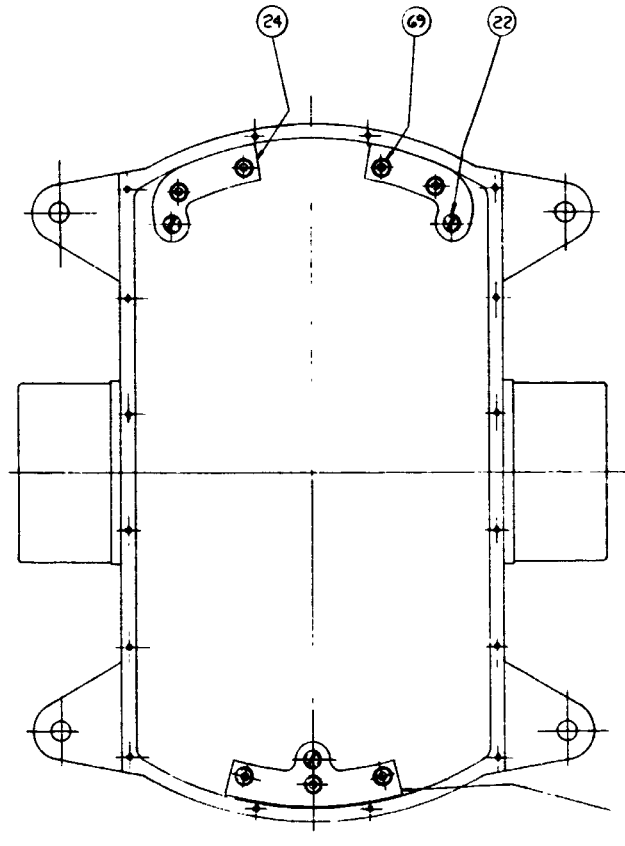
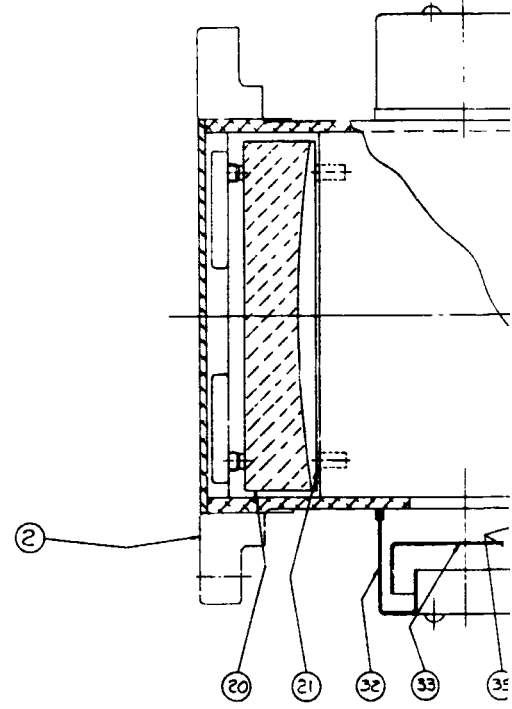

VIEW WITH COVER REMOVED



# FOLDOUT FRAME //

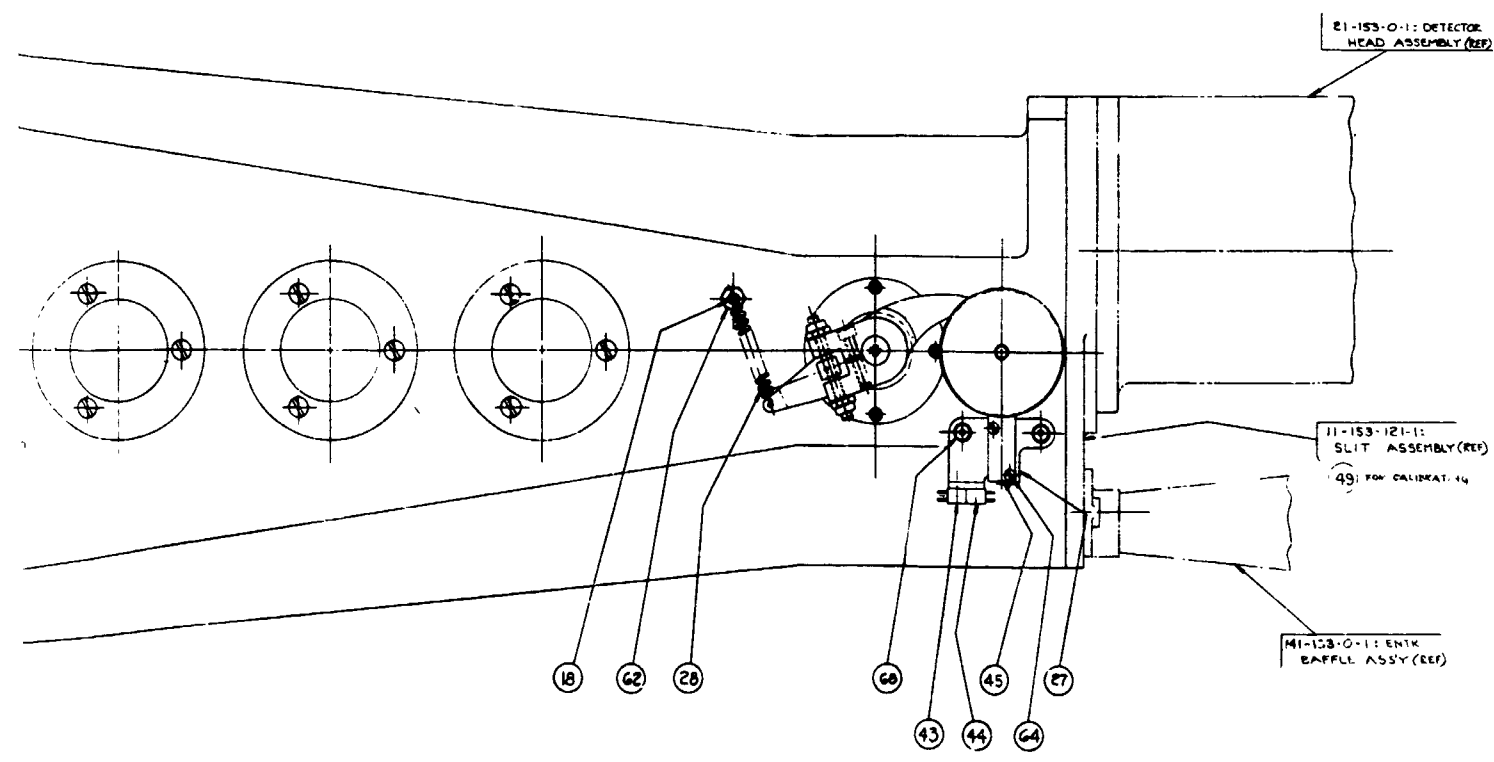
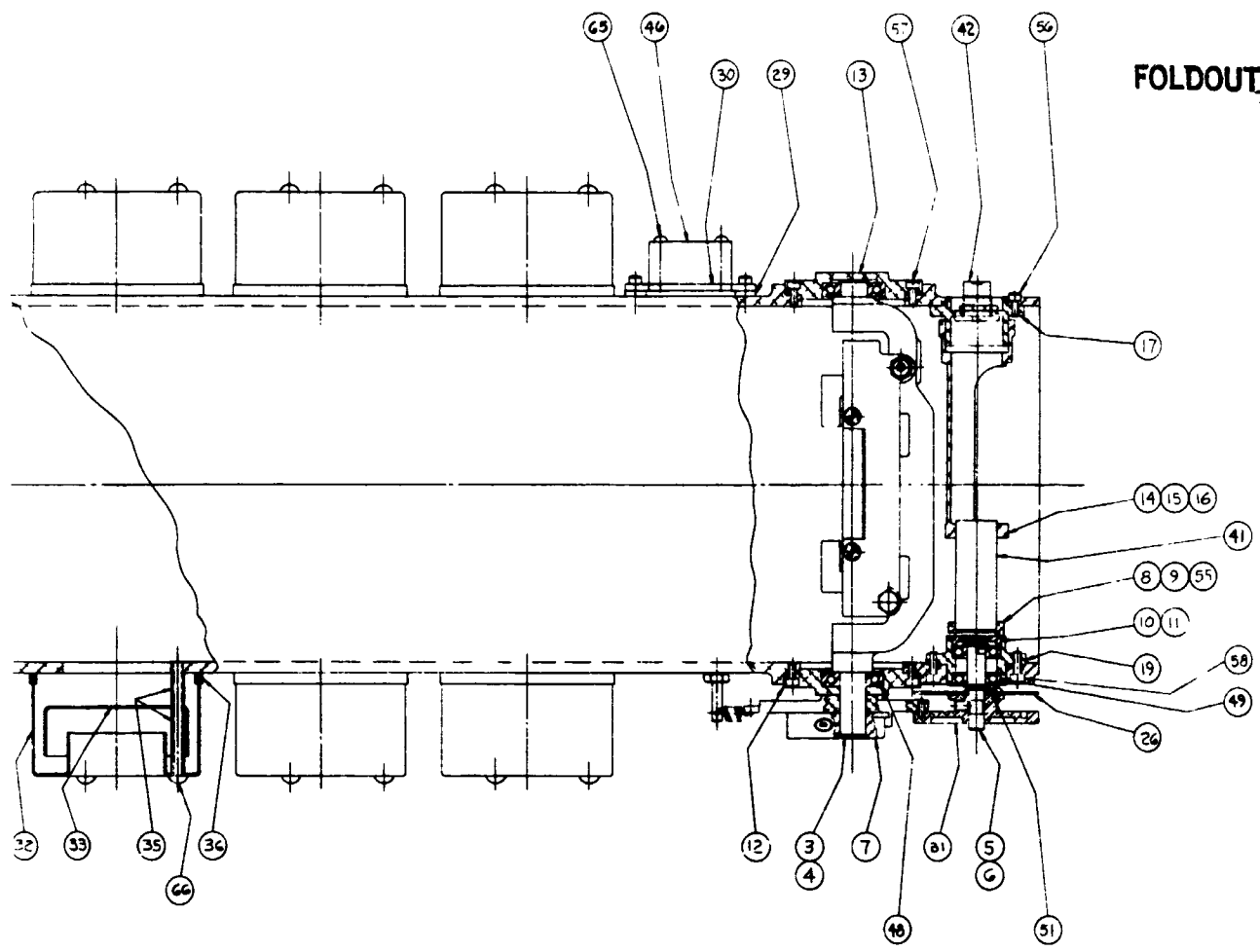

<b>RAY LEE INSTRUMENTS</b> 5 METAL COAT OPTIC		PART NO. 13 153-0-1
DATE 7-15-51	DRAWN BY J. L. H.	CHECKED BY J. L. H.
11 153 13 153-0-1		

17.11  
22 MAR 71  
CHL

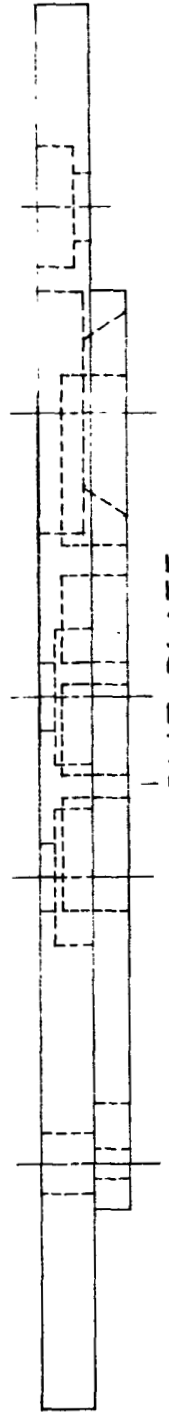
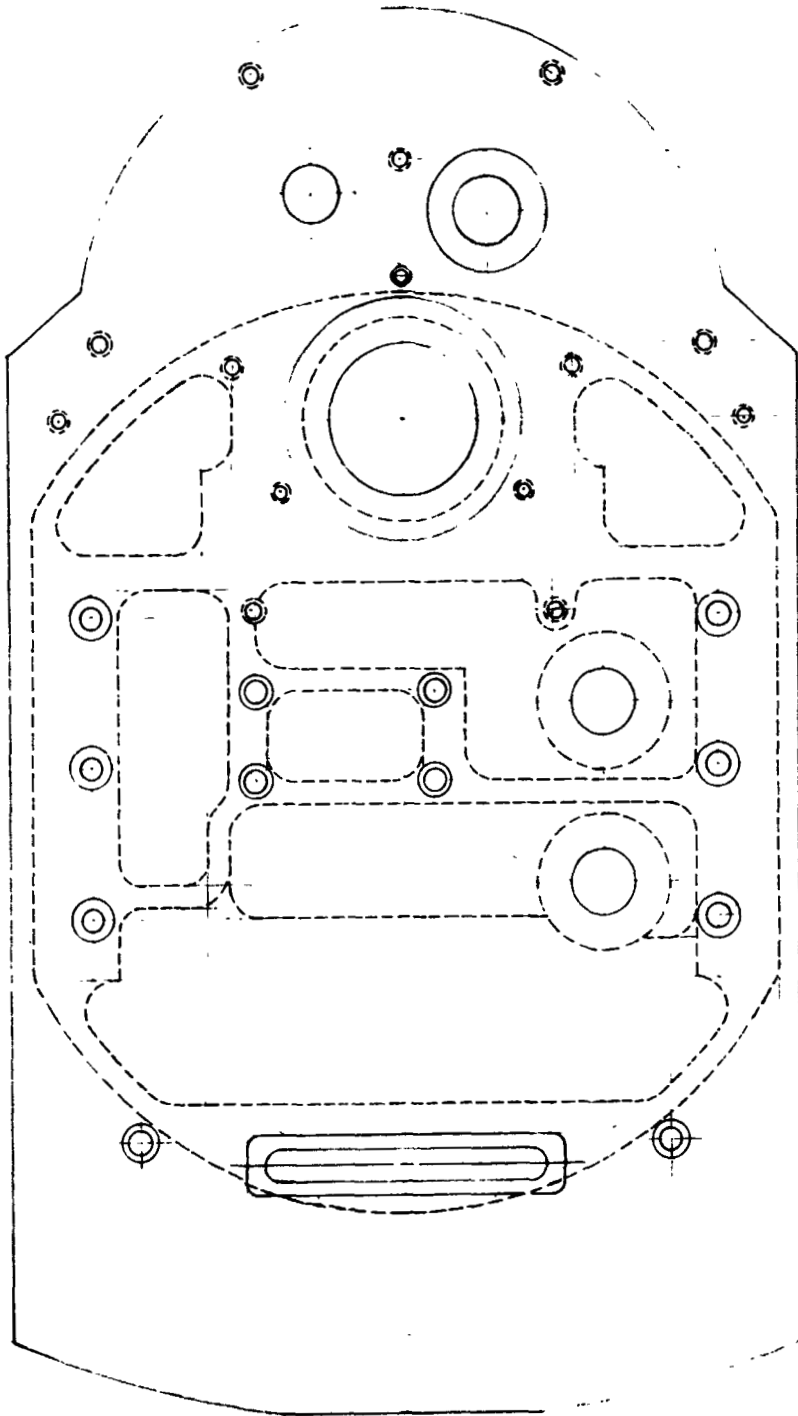

SLIT PLATE

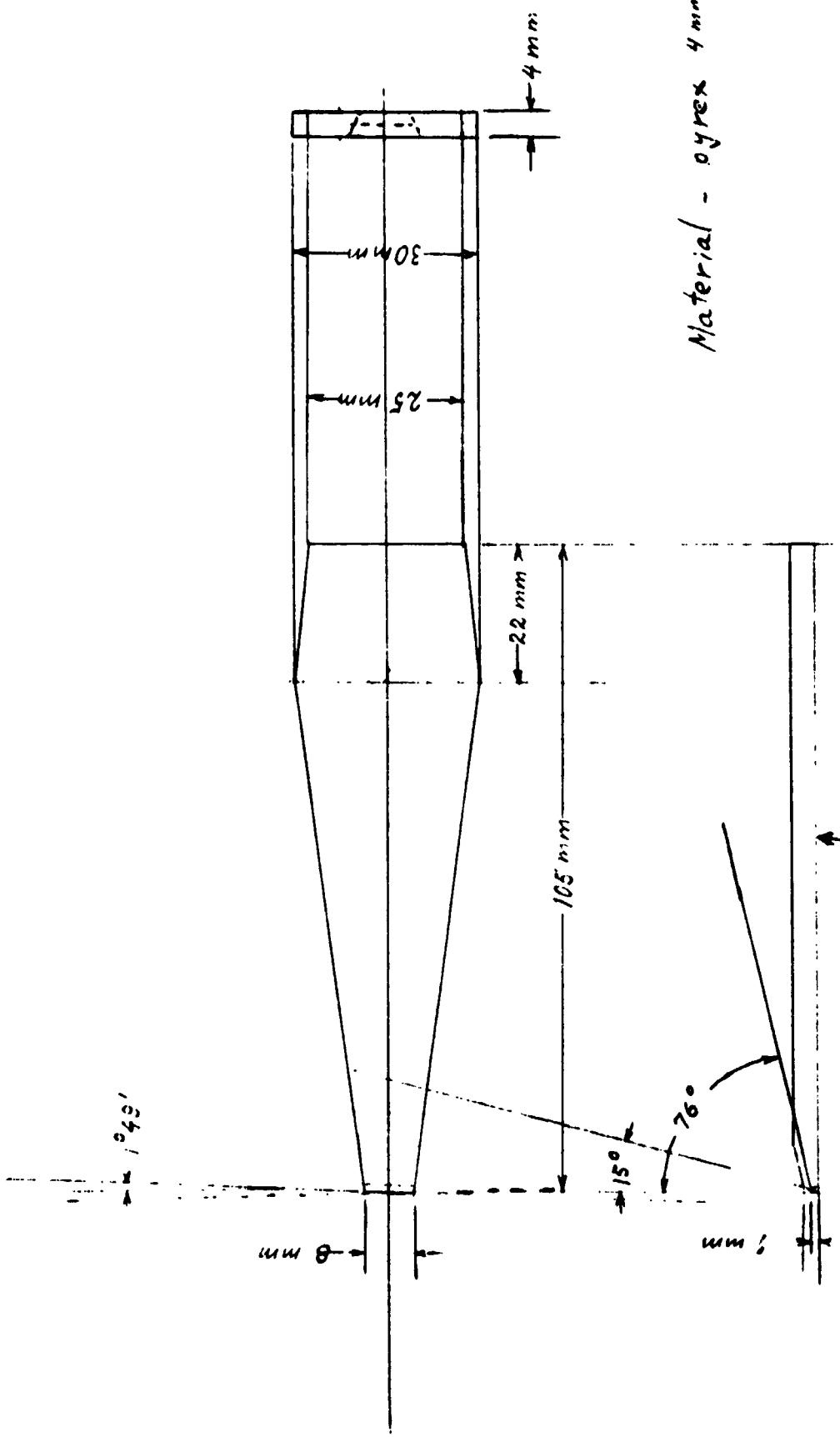

Material - pyrex 4 mm thick

polished for U.V. & coated with Al  
 Make 2 mirrors as above and 2 mirrors with 1049' angle ground  
 as shown by dashed line so as to have two sets of matching pairs.

17, 11  
 29 JAN 71  
 MN

SLIT MIRRORS for 1/2 M Ebert Spectrometer NASA Launch 17.11

# FOLDOUT FRAME I

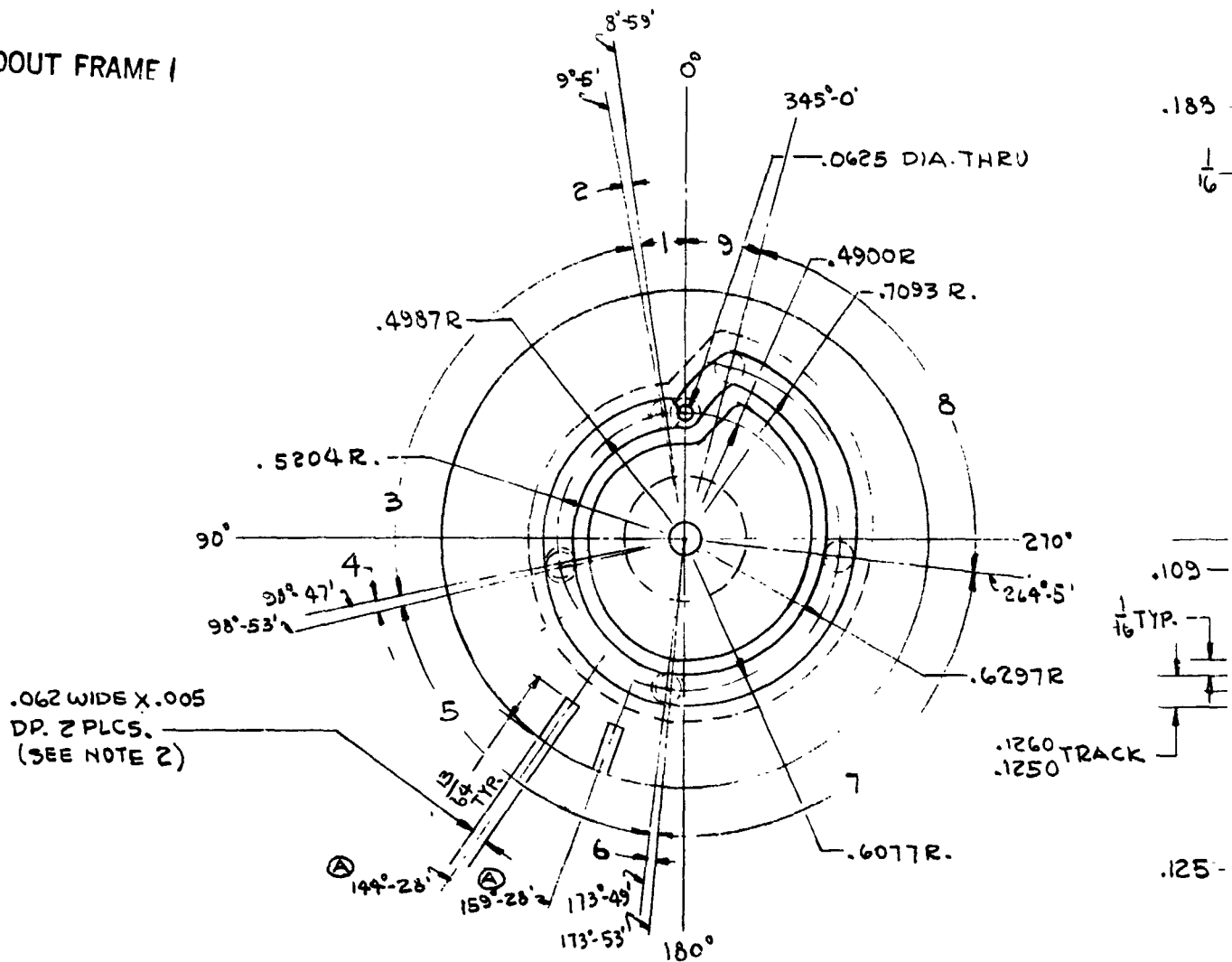

## - DATA - CAM MASTER -

SECT.	DESCRIP.	FALL CHART			
		CAM DEG.	TRACK RADIUS	CAM DEG.	TRACK RADIUS
1	RISE .0087 IN 8°-59' 17 STEPS of .0005 @ 0°-31' 1 STEP of .0002 @ 0°-12'	345°-0'	.7093	354°-30'	.5606
		345°-30'	.7091	355°-0'	.5509
2	DWELL 0.6 ON .4987 R.	346°-0'	.7081	355°-30'	.5411
		346°-30'	.7057	356°-0'	.5314
3	RISE .0217 IN 89°-42' 43 STEPS of .0005 @ 2°-4' 1 STEP of .0002 @ 0°-51'	347°-0'	.7013	356°-30'	.5217
		347°-30'	.6950	357°-0'	.5124
4	DWELL 0.6 ON .5204 R	348°-0'	.6869	357°-30'	.5043
		348°-30'	.6776	358°-0'	.4979
5	RISE .0873 IN 74°-56' 43 STEPS of .002 @ 1°-43' 1 STEP of .0013 @ 1°-7'	349°-0'	.6678	358°-30'	.4936
		349°-30'	.6581	359°-0'	.4911
6	DWELL 0.4 ON .6077 R.	350°-0'	.6483	359°-30'	.4901
		350°-30'	.6386	360°-0'	.4900
7	RISE .0220 IN 90°-12' 44 STEPS of .0005 @ 2°-3'	351°-0'	.6289		
		351°-30'	.6191		
8	RISE .0796 IN 80°-55' 79 STEPS of .001 @ 1°-1' 1 STEP of .0006 @ 0°-36'	352°-0'	.6094		
		352°-30'	.5996		
9	FALL .2193 IN 15°-0' CYCLOIDAL CURVE (PER CHART)	353°-0'	.5899		
		353°-30'	.5801		
		354°-0'	.5704		

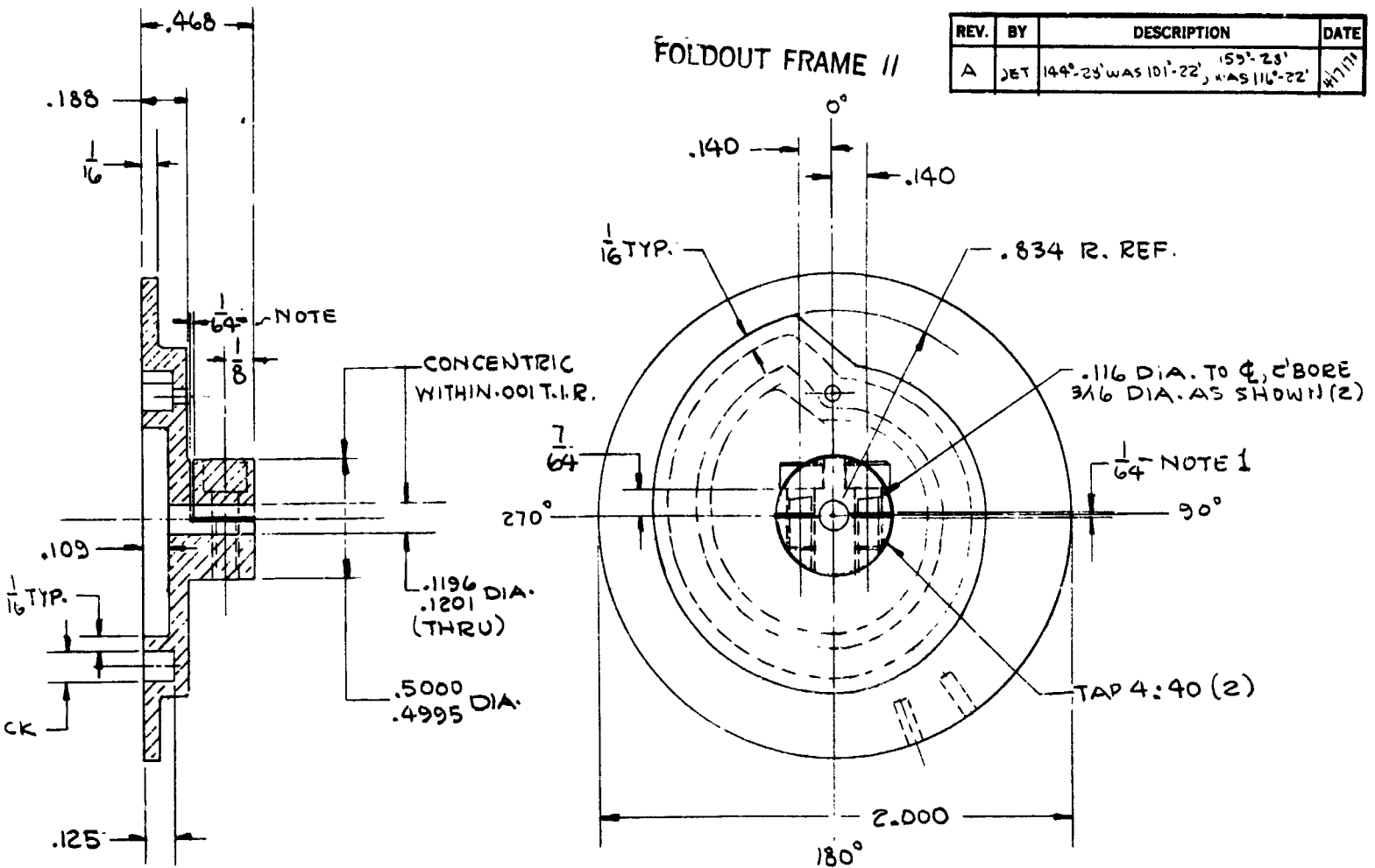

**NOTES -**

- 1) SPLIT HUB AS SHOWN AFTER CUTTING CAM PROFILE.
- 2) BLACK OXIDE FINISHED CAM. CUT THRU BLACK FINISH 2 PLACES, CENTERED @ 144°-28' & 159°-28' AS SHOWN. MAINTAIN FINISH & SHARP EDGES FOR OPTICAL PICKUP.

<b>CONTROL NO.</b>	<b>FOR</b> FASTIE, AEROBEE 350		<b>NO. REQ'D</b>
<b>MATERIAL</b> BRONZE, ALLOY 660	<b>TOLERANCES UNLESS OTHERWISE SPECIFIED</b> DEC XXX ± .008 XXXX ± .0008 FRAC ± 1/64 ANG ± 15'	<b>RAY LEE INSTRUMENTS</b> PIKESVILLE, MD. 21208	
<b>FINISH</b> BLACK OXIDE (SEE NOTE 2)		DWN DATE JET 2/22/71	<b>WAVELENGTH CAM</b> 1175 Å - 1675 Å, 3600 L GRATING FOR UVS TYPE 1/2 M. SPECTROM.
<b>NOTE:</b> THE INFORMATION DISCLOSED HEREIN IS THE PROPERTY OF RAY LEE INSTRUMENTS. ALL PROPRIETARY RIGHTS FOR DESIGN REPRODUCTION OR MANUFACTURE ARE RESERVED BY RAY LEE INSTRUMENTS EXCEPT AS EXPRESSLY GRANTED TO THE U. S. GOVERNMENT. THIS DOES NOT APPLY TO VENDOR PARTS.	<b>SCALE</b> 2:1	<b>CHKD DATE</b>	<b>APPR DATE</b>
		<b>MOD. NO.</b> 137	<b>DWG NO.</b> 10-137-0-20

DATE	BY	REVISION RECORD	AUTH.	CHK.

17.11  
2 APR 71  
CHL

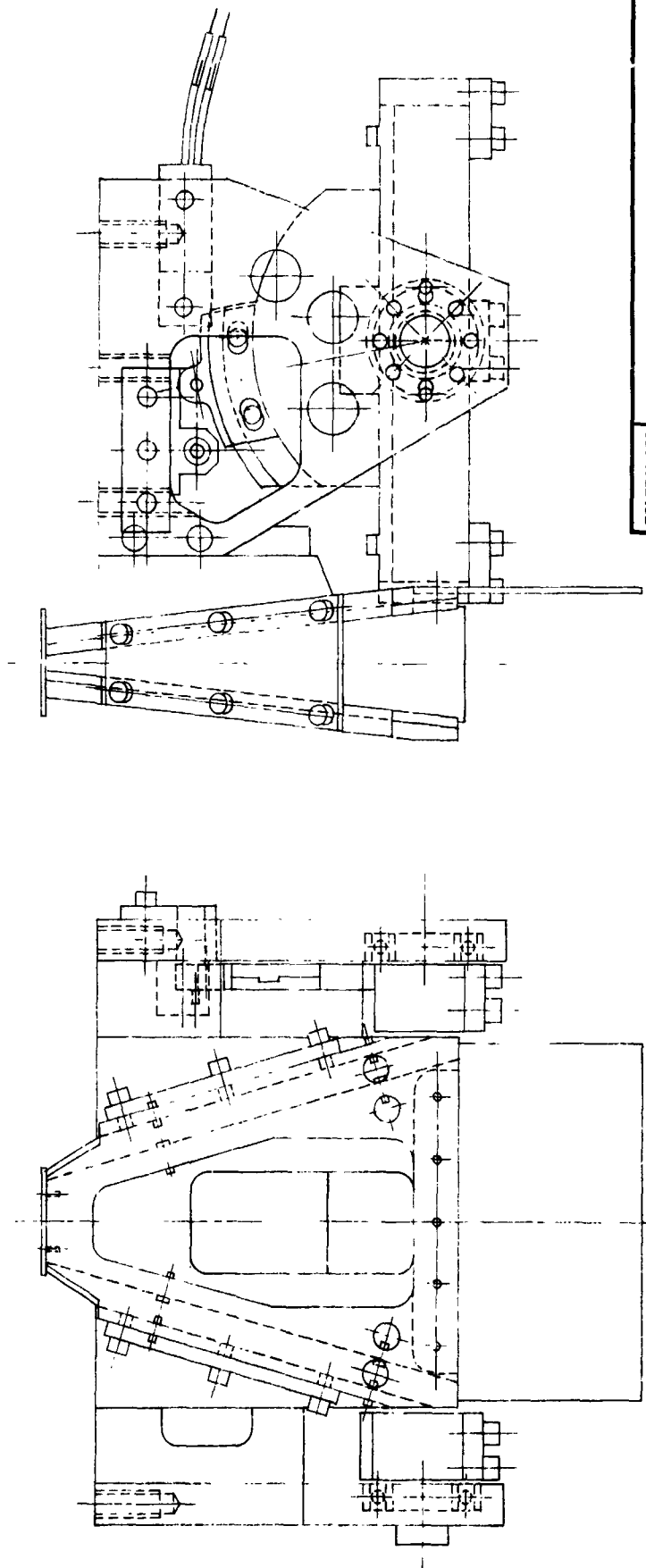

TOLERANCES (EXCEPT AS NOTED)		DRAWN BY C. H. LAKE	
DECIMAL	±	SCALE	APPROVED BY
FRACTIONAL	±	TITLE	
ANGULAR	±	DATE	DRAWING NUMBER

17.11.11  
CHL

K&E  
17.11.11  
CHL

17.11  
1 APR 71  
CHL

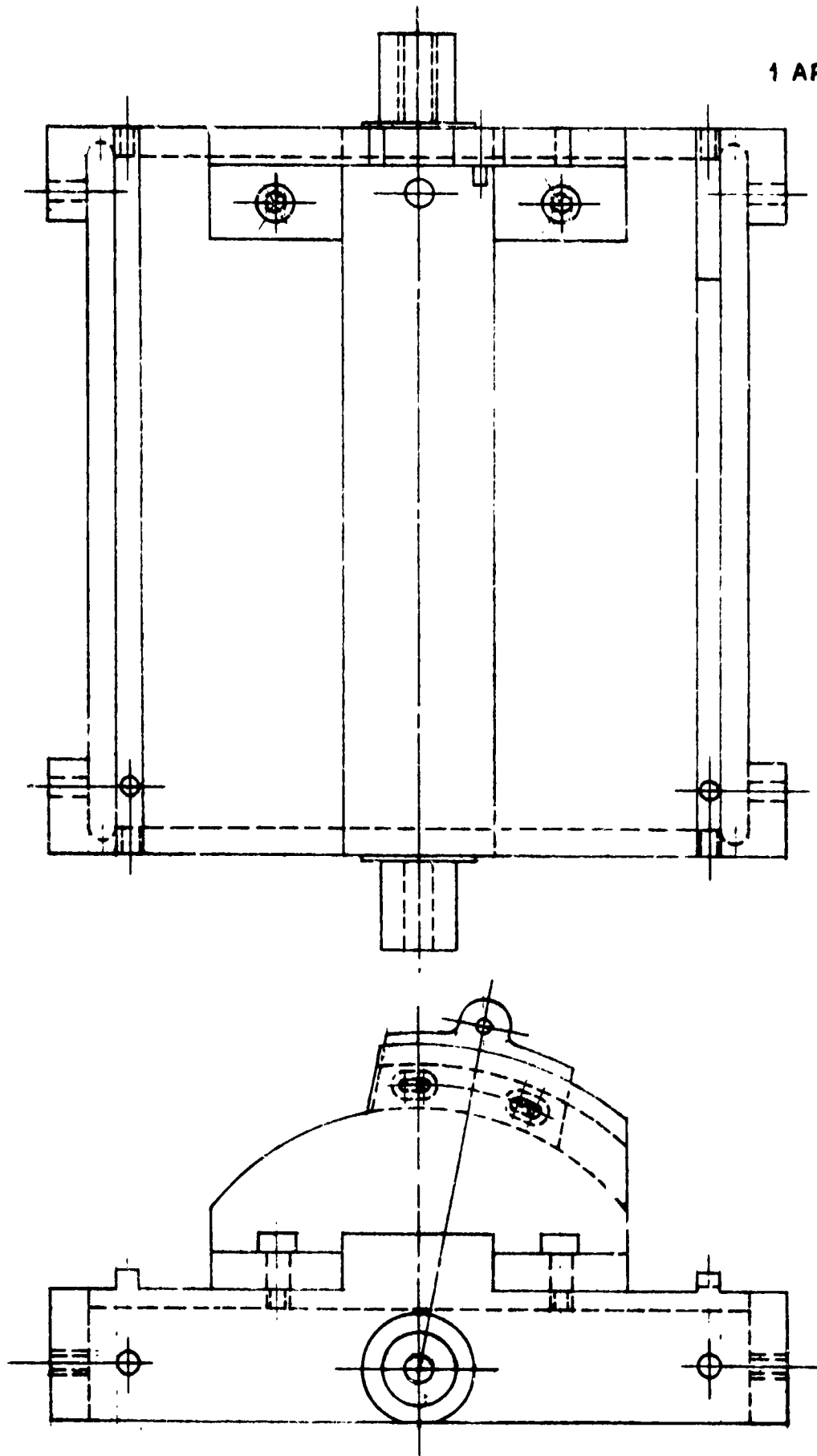

CAM ADJUSTMENT  
DETAIL

17.11  
16 APR 71  
CHL

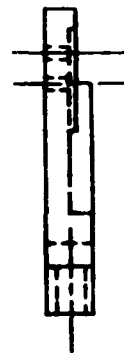
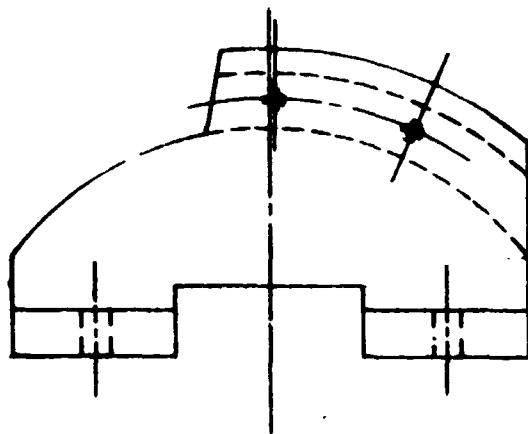
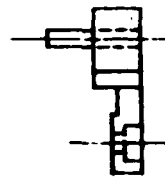
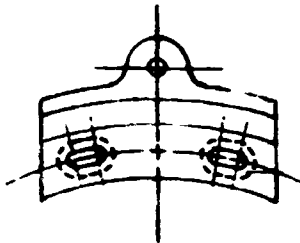
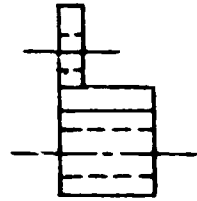
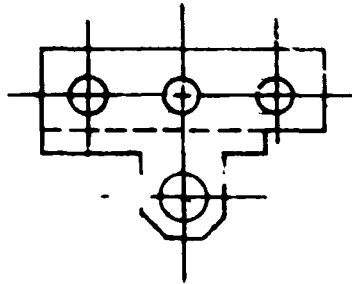

CAM ADJUSTMENT  
PARTS



17.11  
30 MAR 71  
CHL

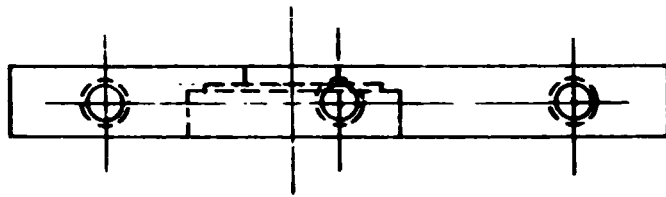
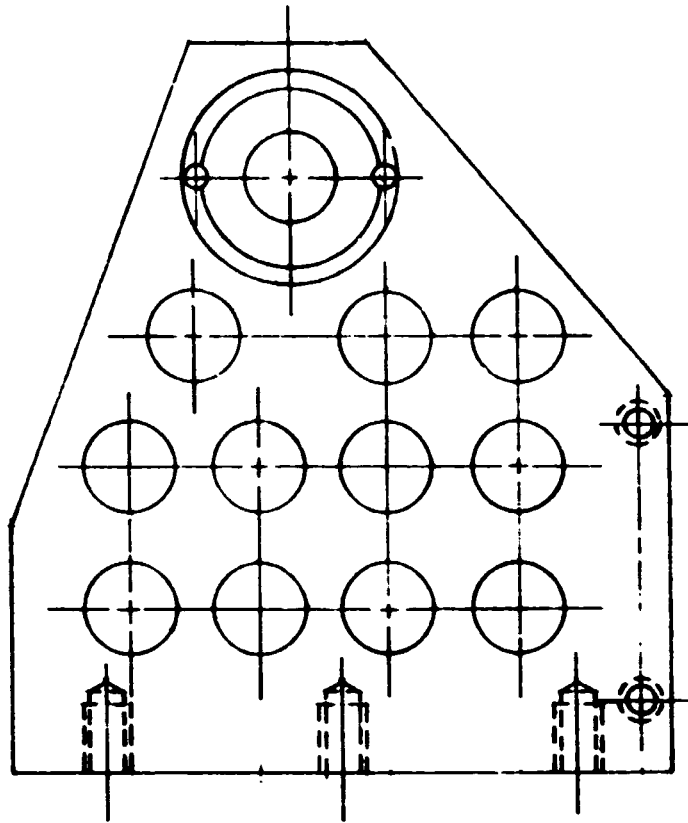

BEARING  
RETAINER  
PLATE

17.11  
30 MAR 71  
CHL

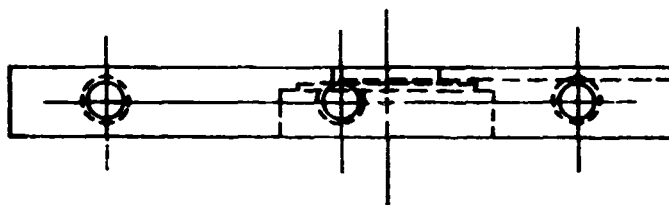
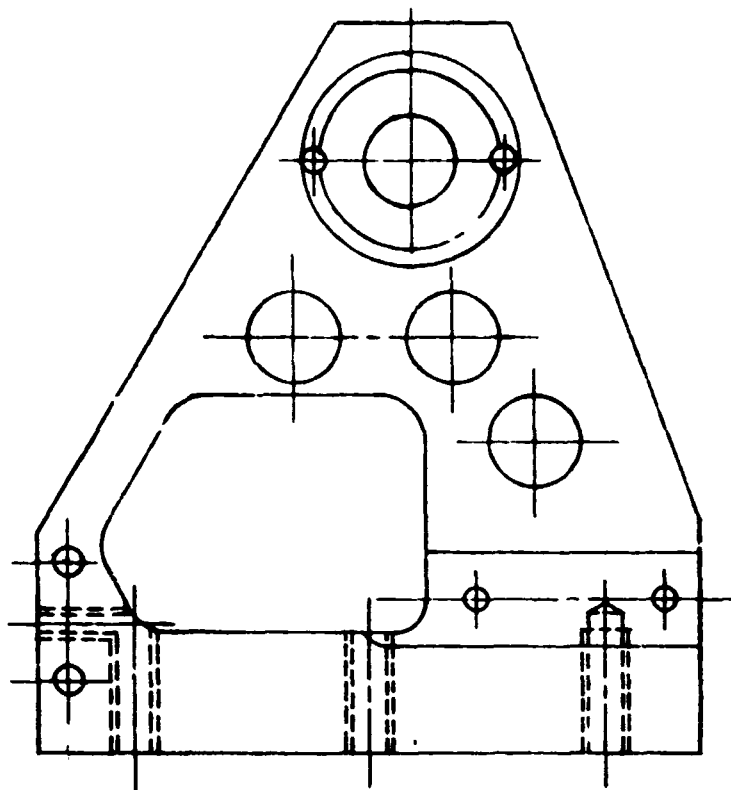

BEARING  
RETAINER  
PLATE

17.11  
31 MAR 71  
CHL

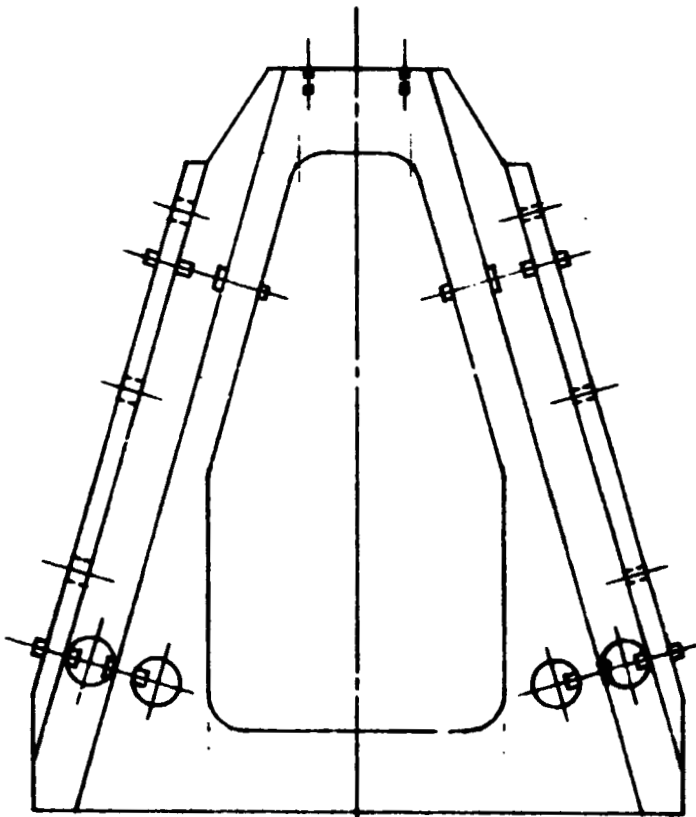
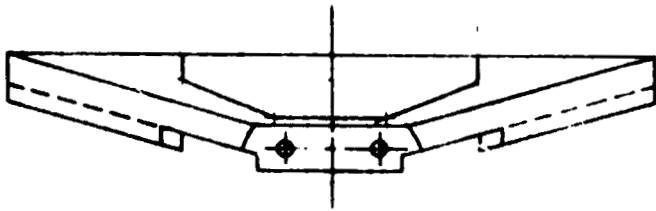

MIRROR RETAINER

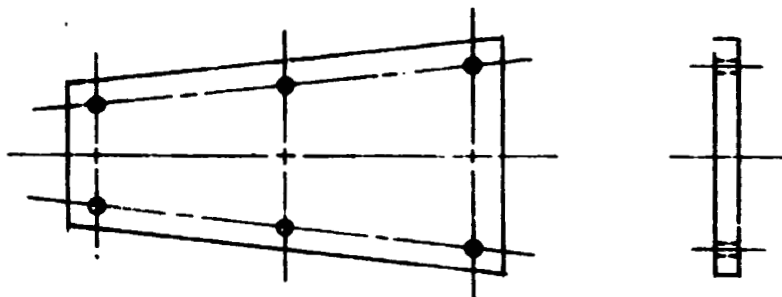

MIRROR COVER PLATE

17.11  
31 MAR 71  
CHL

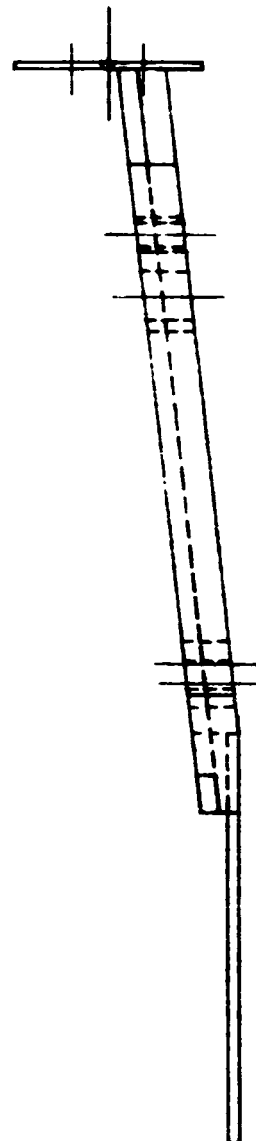
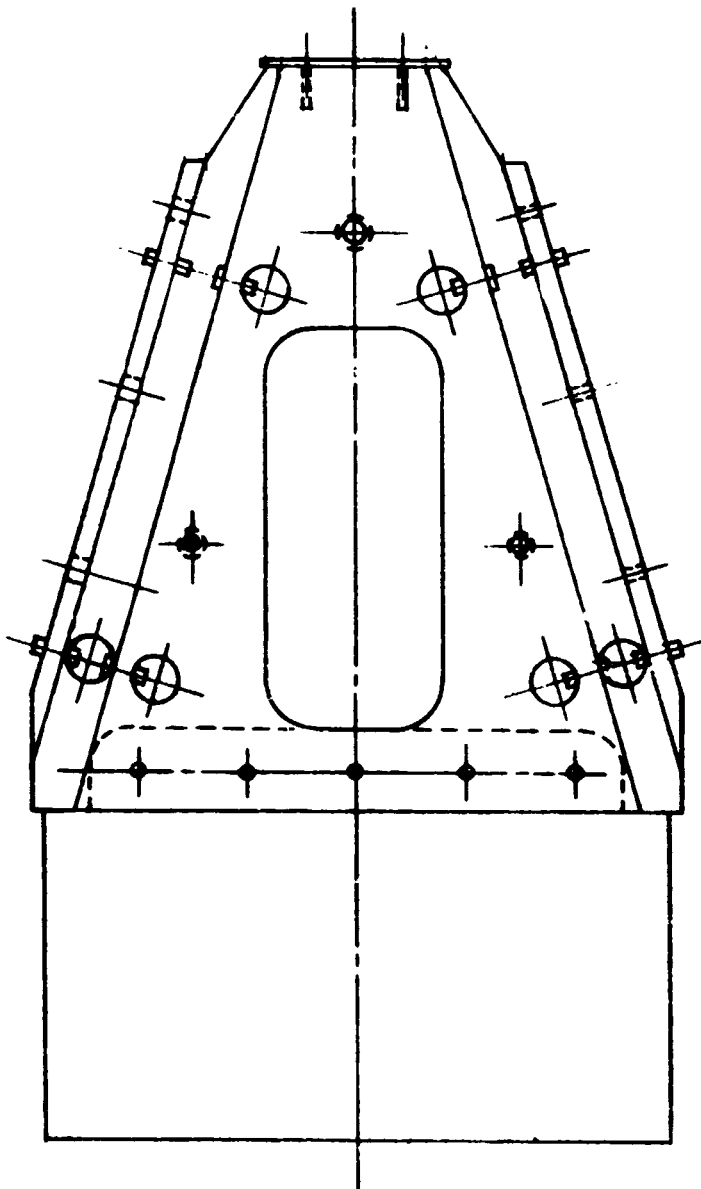
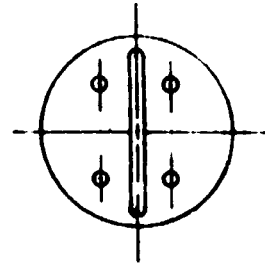
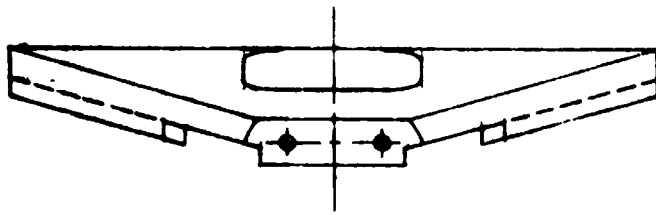

MIRROR RETAINER, SLIT  
PLATE & LIGHT SHIELD

17.11  
1 APR 71  
CHL

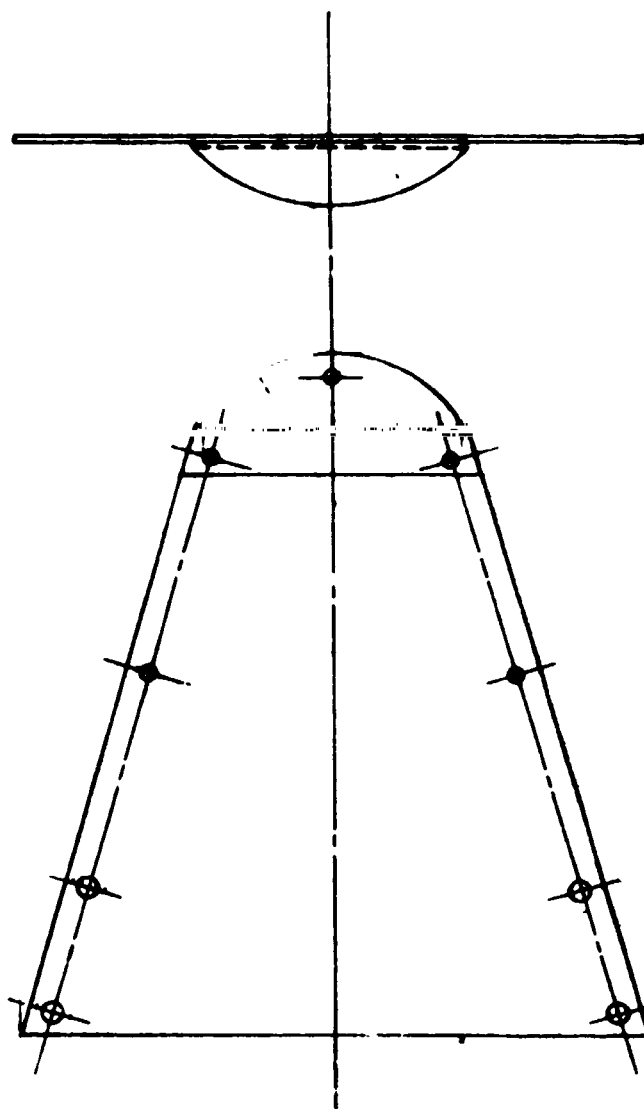

LIGHT SHIELD

17.11  
20 MAR 71  
CHL

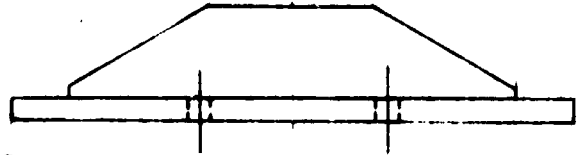
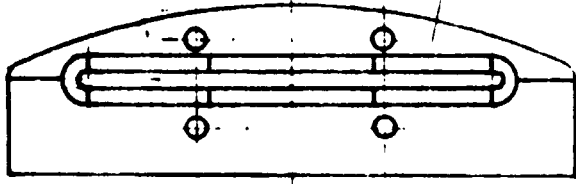

EXIT SLIT

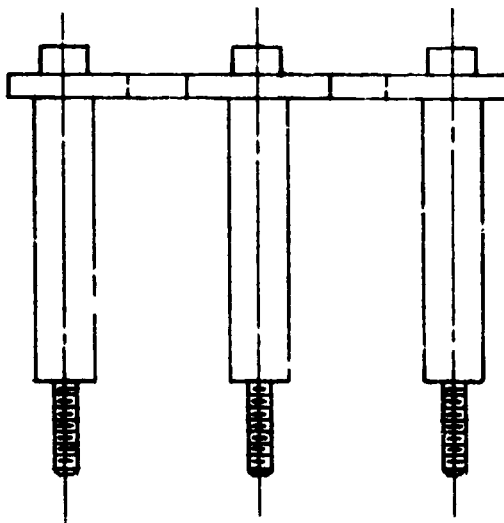
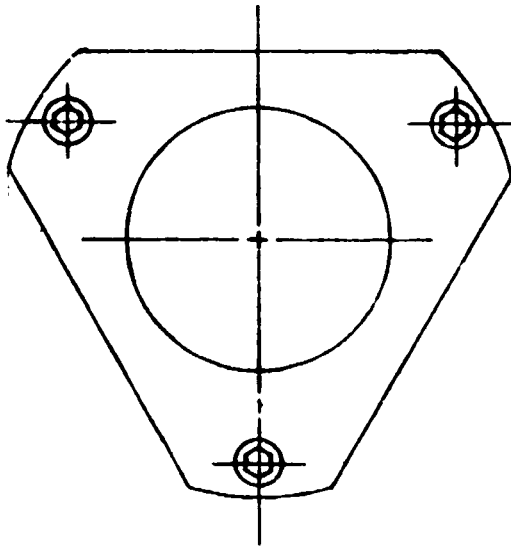

PM TUBE  
CLAMP

17.11  
26 MAR 71  
CHL

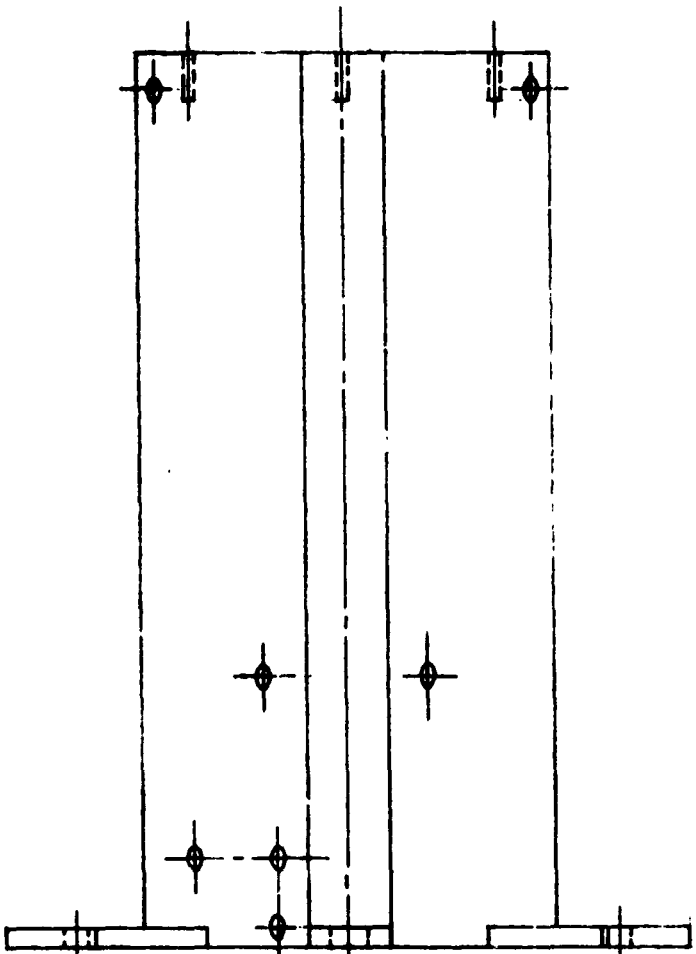
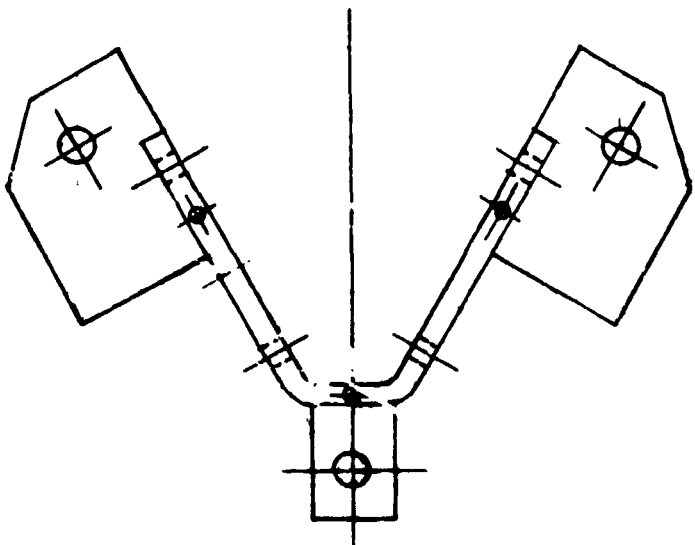

HV & PAD SUPPORT  
BRACKET

17.11  
29 MAR 71  
CHL

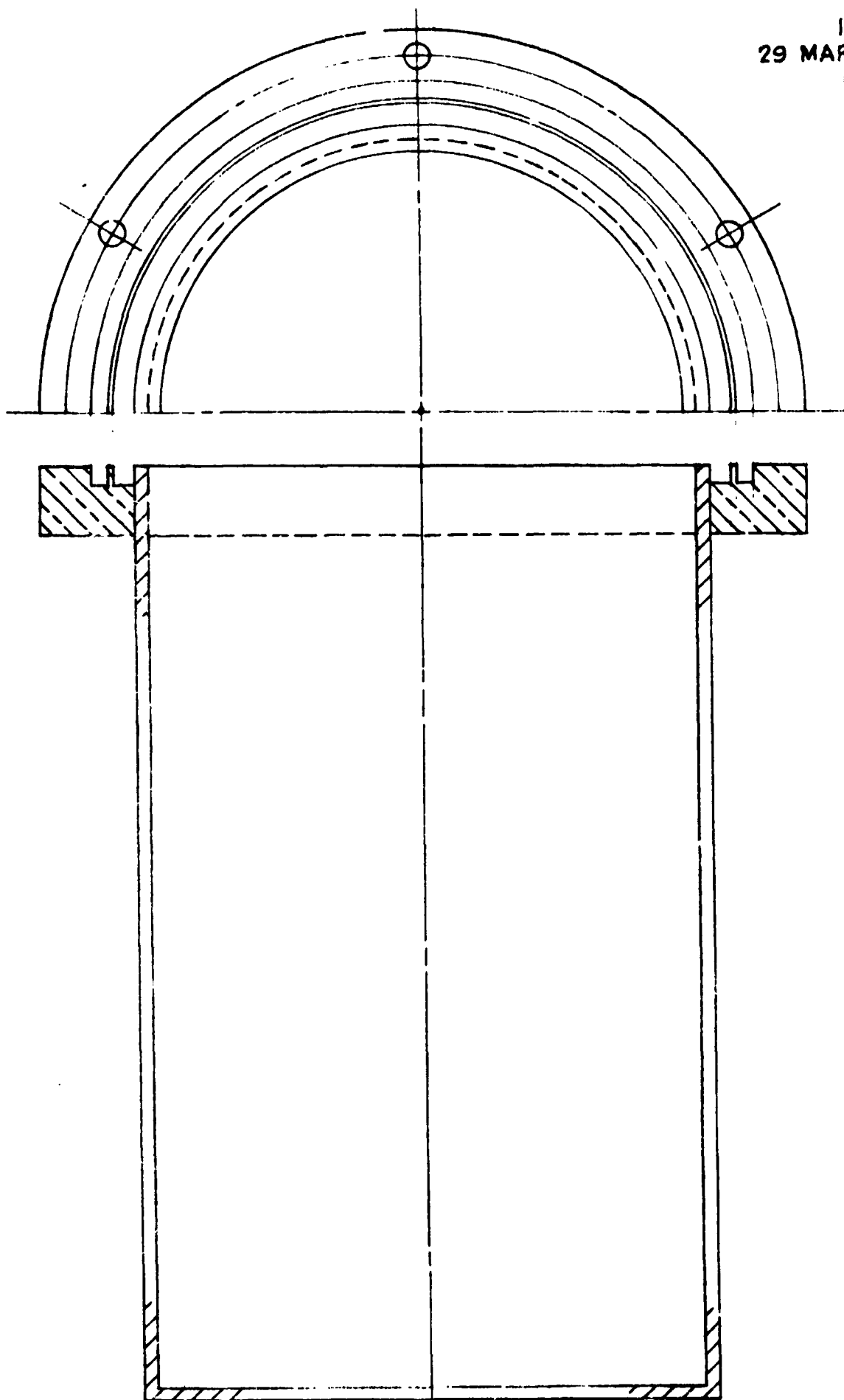

DETECTOR COVER



17.11  
16 APR 71  
CHL

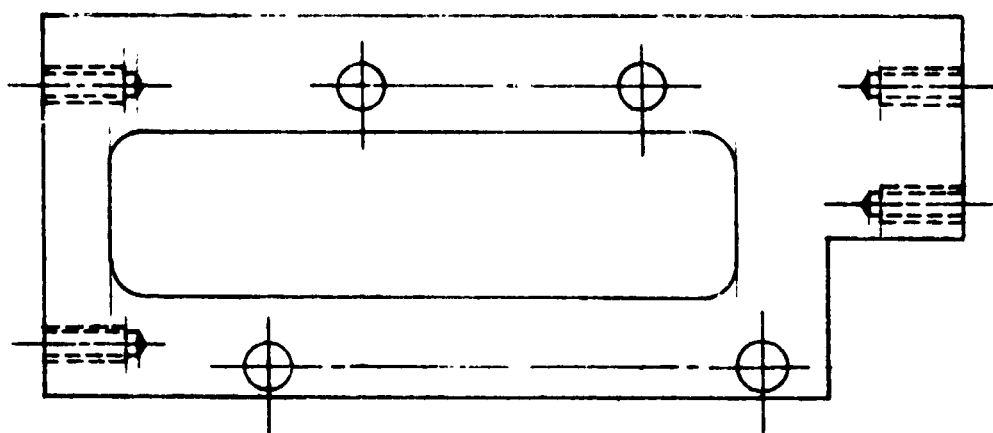
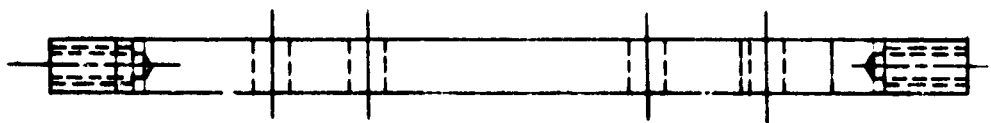

CONNECTING PLATE

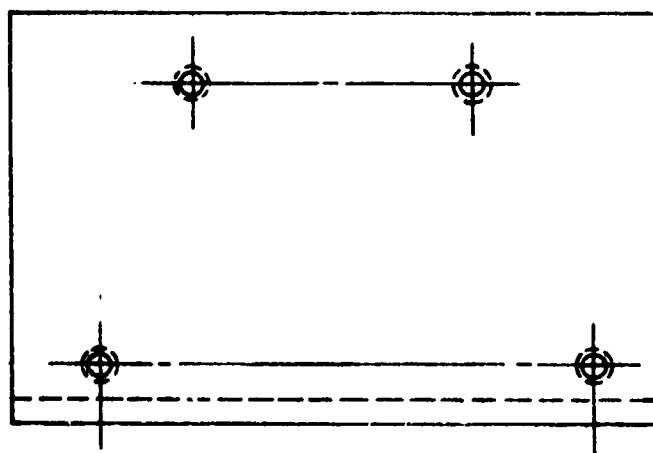

WEDGE

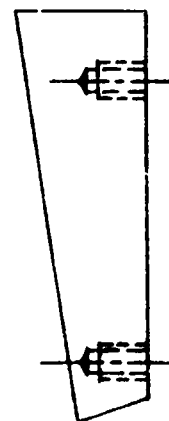

# FOLDOUT FRAME 1

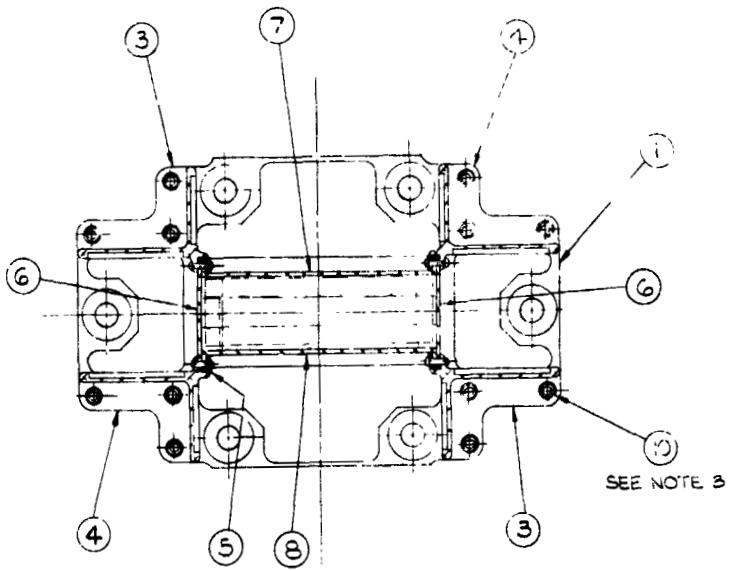

SECTION A-A

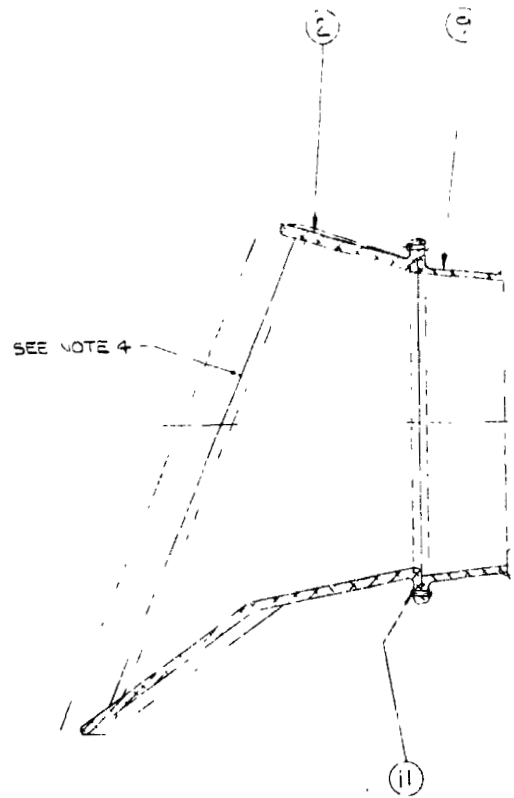

# FOLDOUT FRAME 11

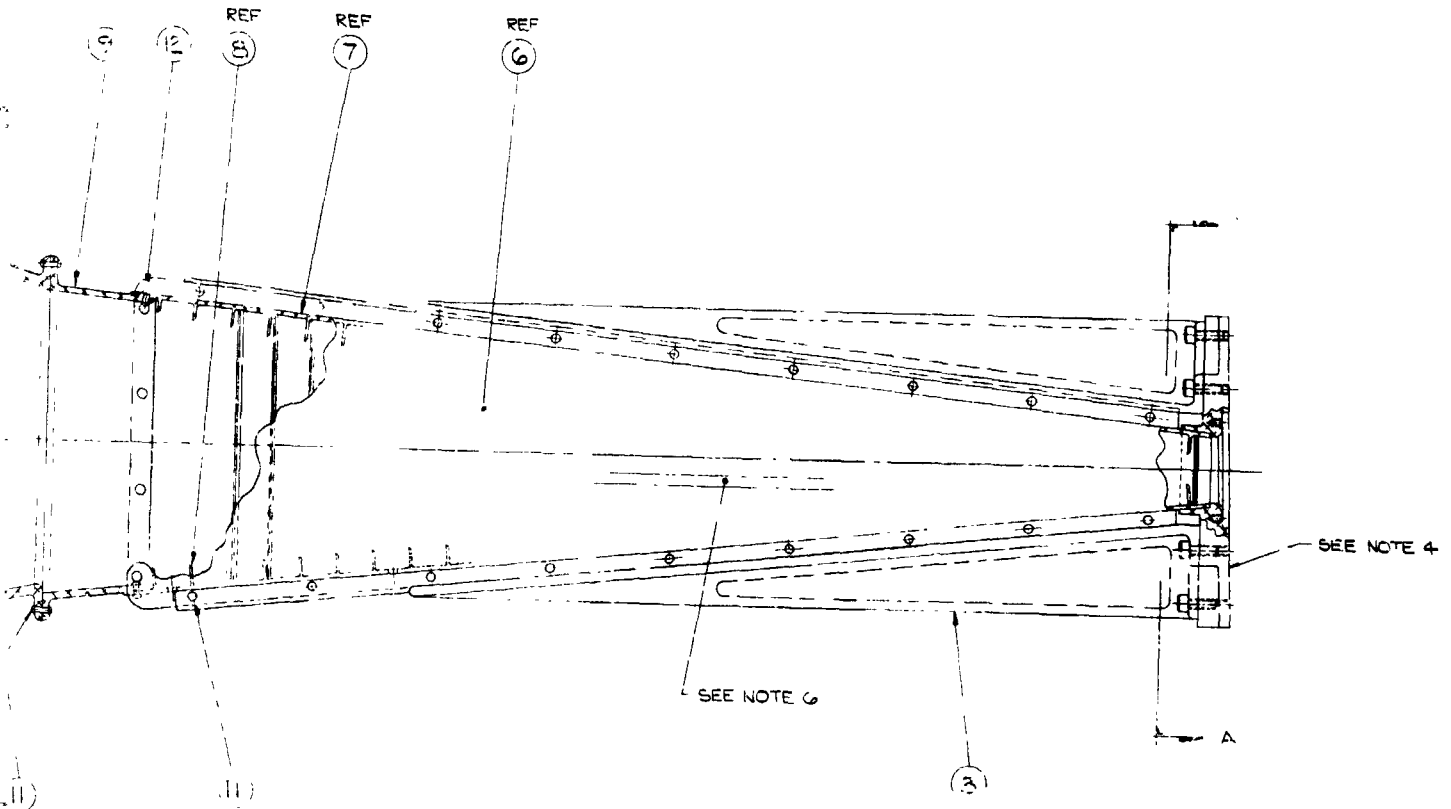

QTY	CODE IDENT	PART OR IDENTIFYING NO	NOMENCLATURE OR DESCRIPTION	MATERIAL DESCRIPTION	MATERIAL SPECIFICATION	ITEM NO
20		MS20410-024	RIVET, UNF HD DUL DIA - CS			12
60		MS20470A25	RIVET, UNF HD OGL DIA - CS			11
12		NAS1352-01	SOC HD CAP SCRE	CORR RESIST ST PL	6-32 X 3/16	10
1		7232-0309	BAFFLE, INTERMEDIATE			9
1		7232-0302-3	BAFFLE PLATES			8
1		7232-0302-2	BAFFLE PLATES			7
2		7232-0308-1	BAFFLE PLATES			6
4		7232-0315	RIVET STRIP			5
2		7232-0307	GUSSET			4
2		7232-0306	GUSSET			3
1		7232-0310	BAFFLE TOP			2
1		7232-0305	BASE			1

UNLESS OTHERWISE SPECIFIED ALL DIMENSIONS ARE IN INCHES TOLERANCES:		DRAWN		DATE	
FRACTIONS	± .04	BY	DATE		
DECIMALS	MAX ± .005	CHECKED	DATE		
ANGLES	± 15'	APPROVED			
	BREAK ALL SHARP EDGES	APPROVED			
MATERIAL		RELEASED			
FINISH		SIGNATURE	DATE	CODE IDENT NO	S/E
7232-0000				1792E	E
NEXT ASSEMBLY	USED ON	NEXT ASSEMBLY	FINAL ASSEMBLY	7232-0300	
APPLICATION	QUANTITY	SEE NOTE 4		SCALE 1:1	SHEET OF 1

**RAY LEE INSTRUMENTS**  
PIKEVILLE, MARYLAND

BAFFLE ASSEMBLY  
UV SPECTROMETER EXP S-169

17.11  
29 MAR 71  
CHL

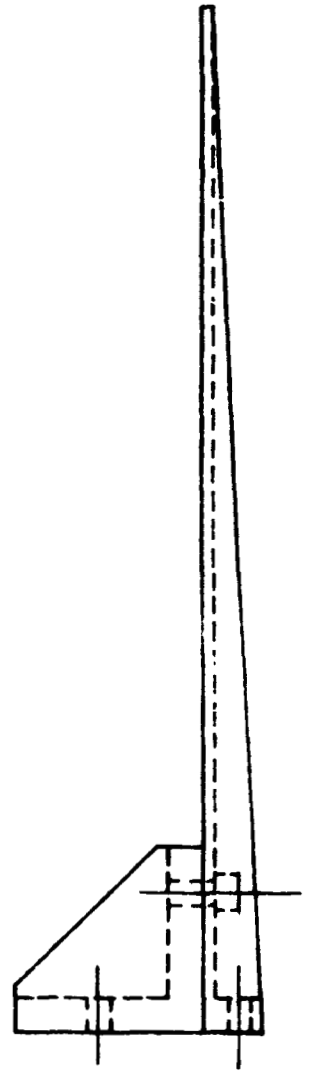
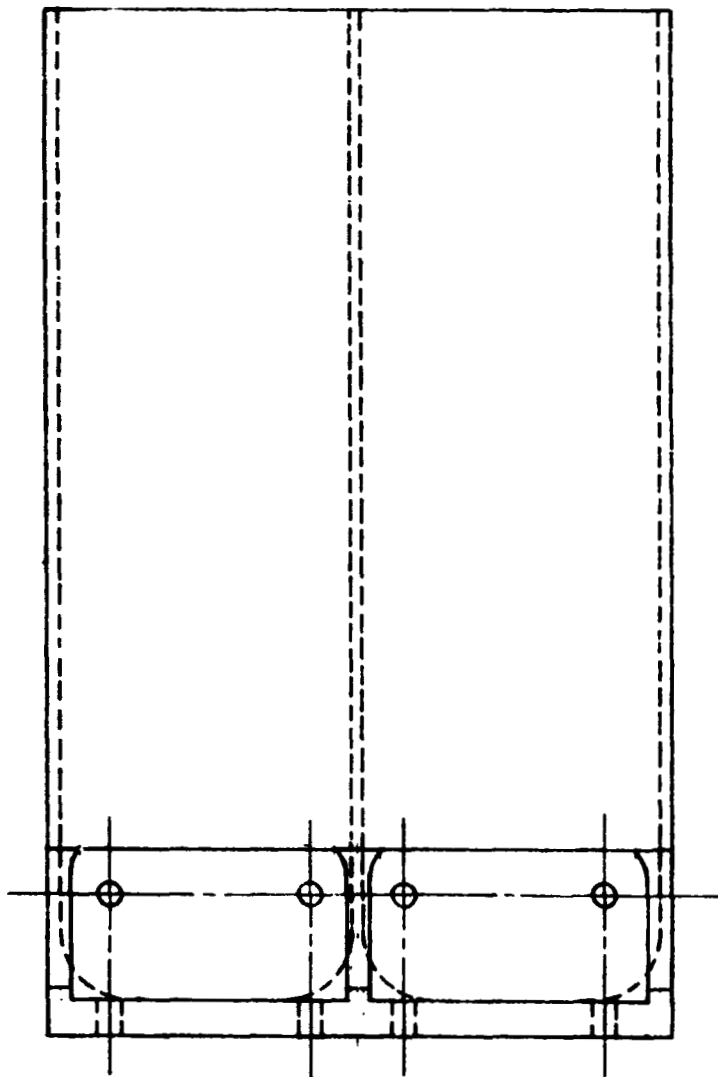
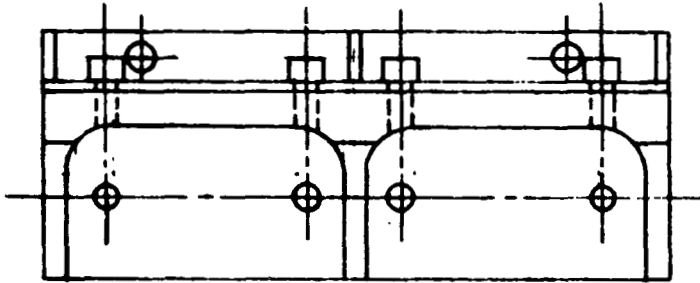

INTERNAL ENTRANCE  
SLIT BAFFLE

17.11  
25 MAR 71  
CHL

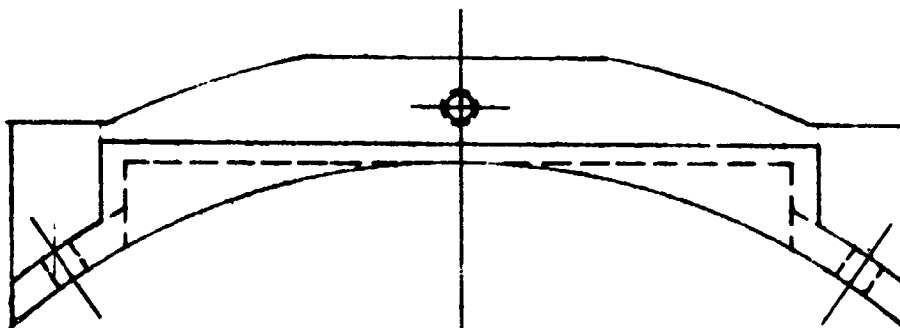
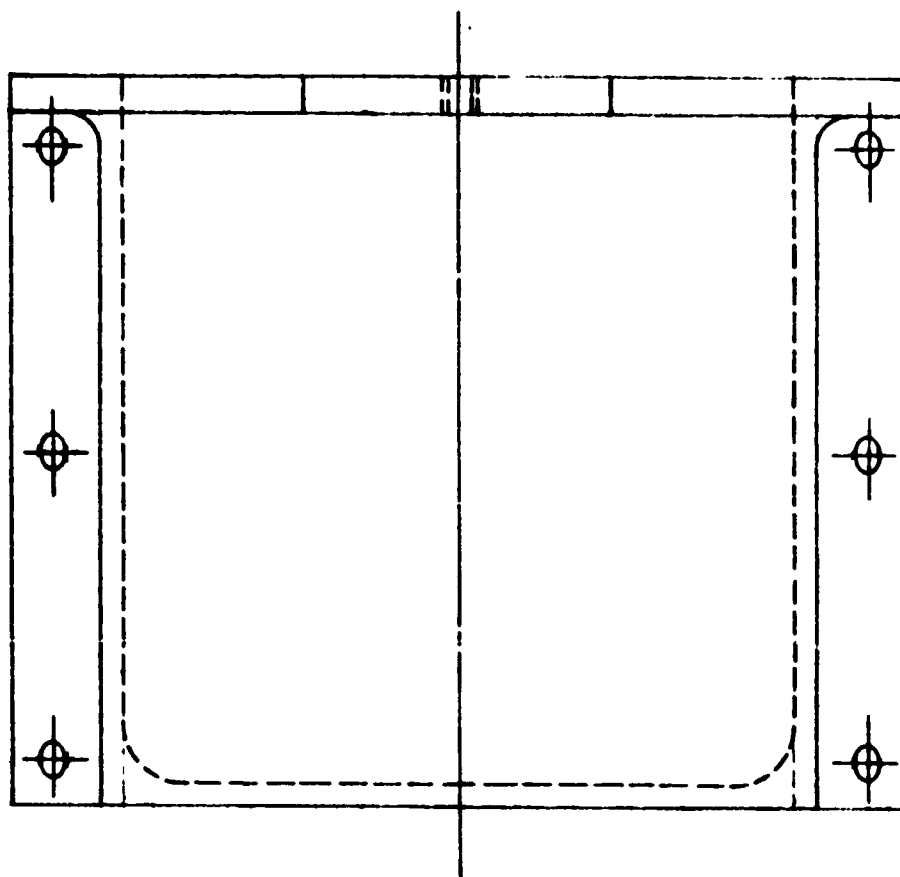

DATA MODULE  
MOUNTING PLATE

17.11  
25 MAR 71  
CHL

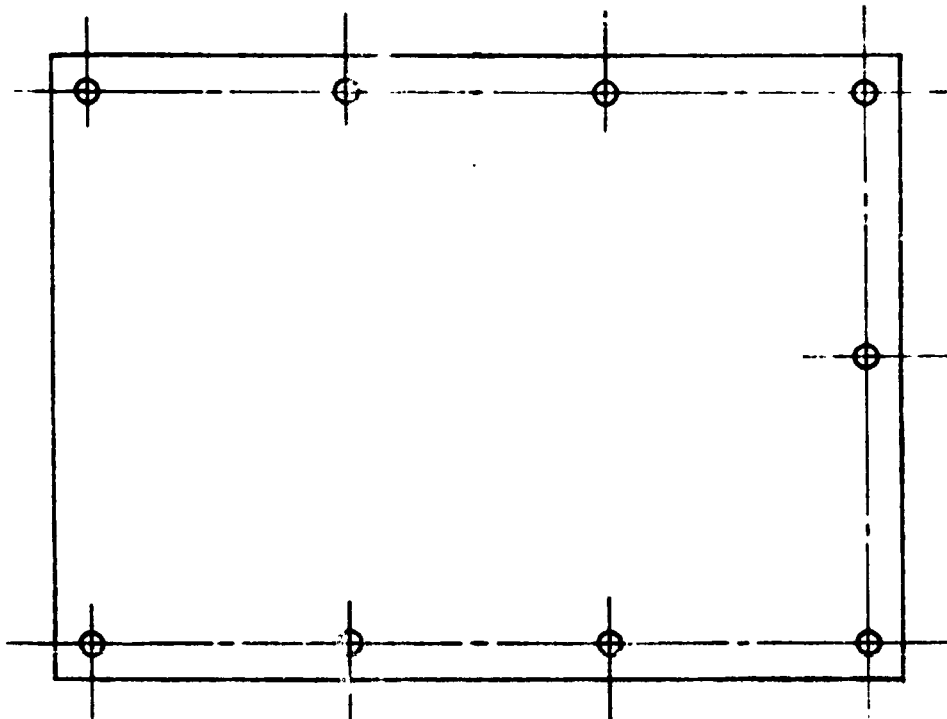
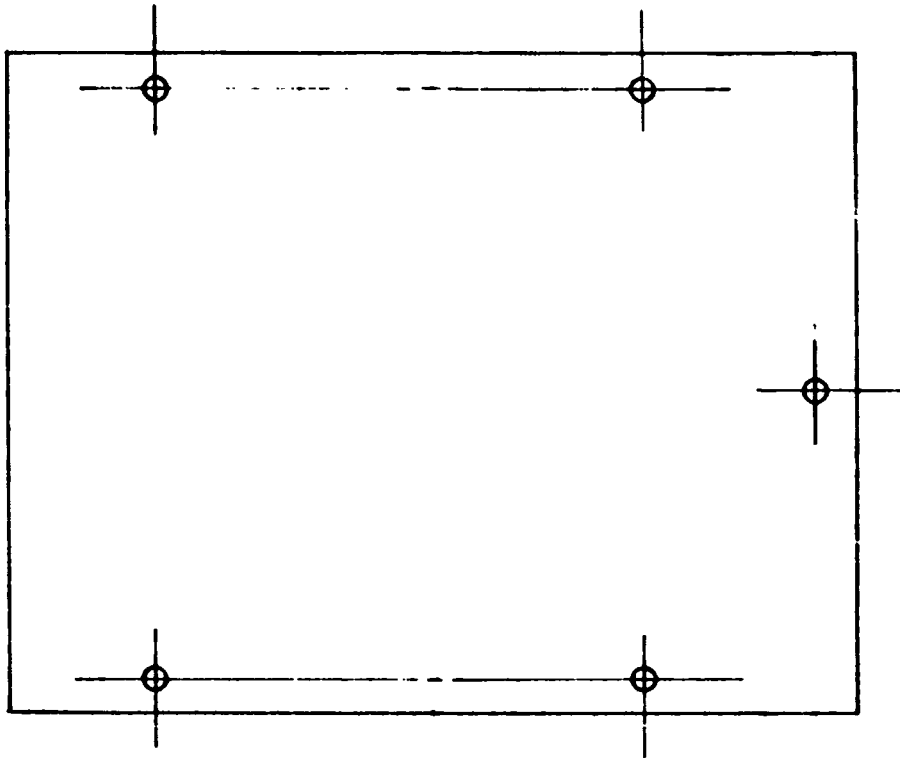

PLATES OVER  
GOUGED HOLES

17.11  
25 MAR 71  
CHL

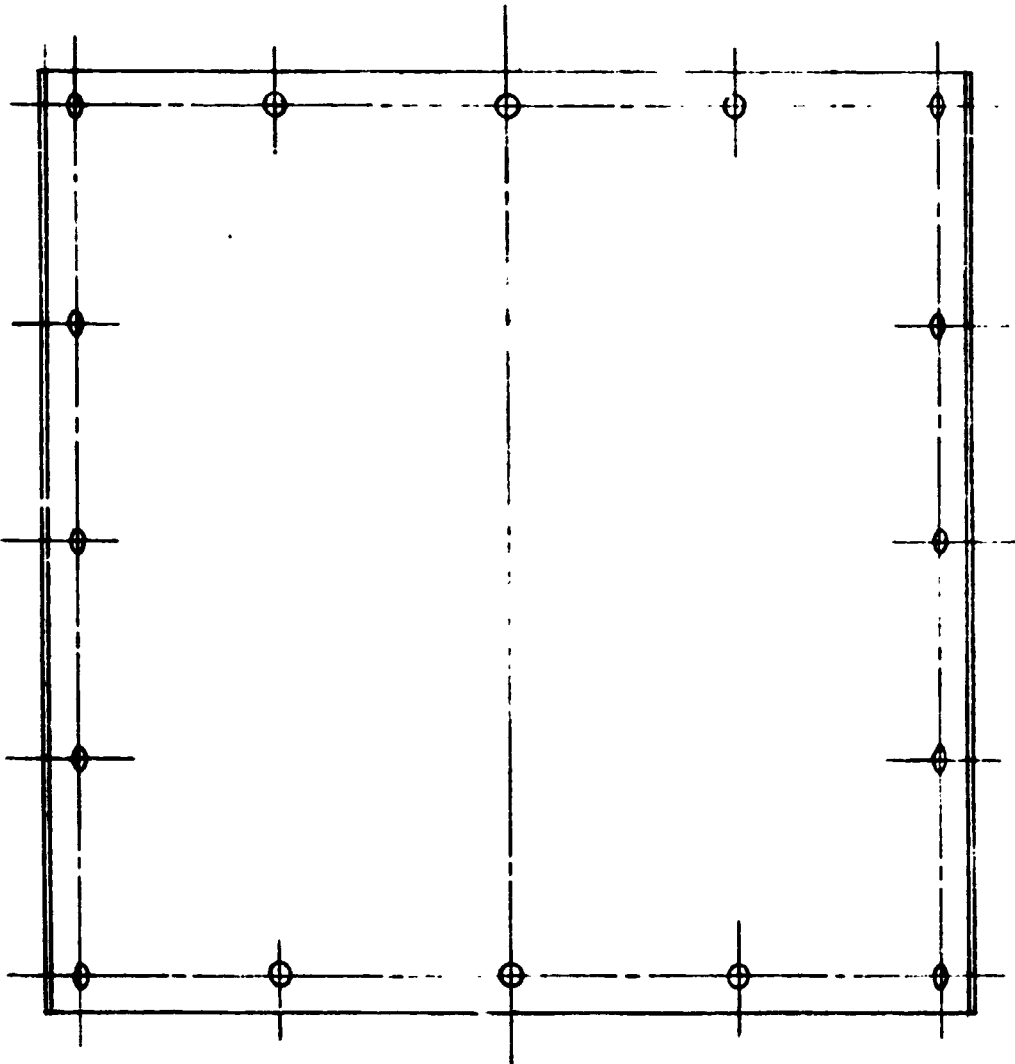
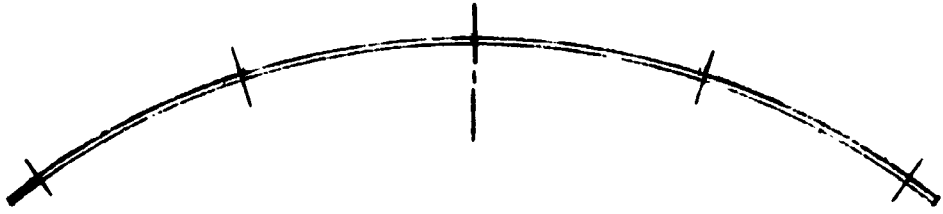

PLATE OVER  
GOUGED HOLES

17.11  
25 MAR 71  
CHL

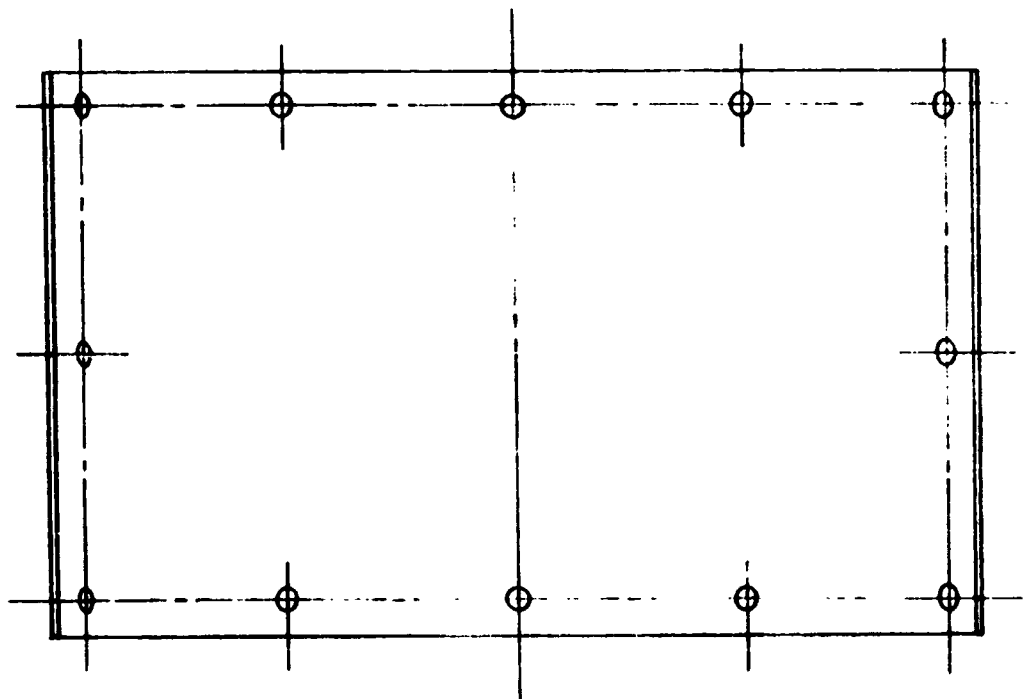
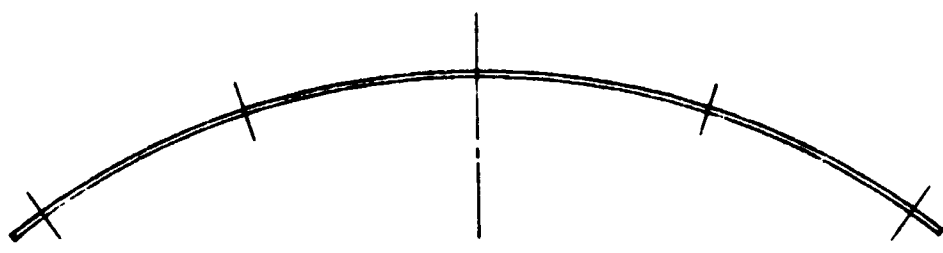
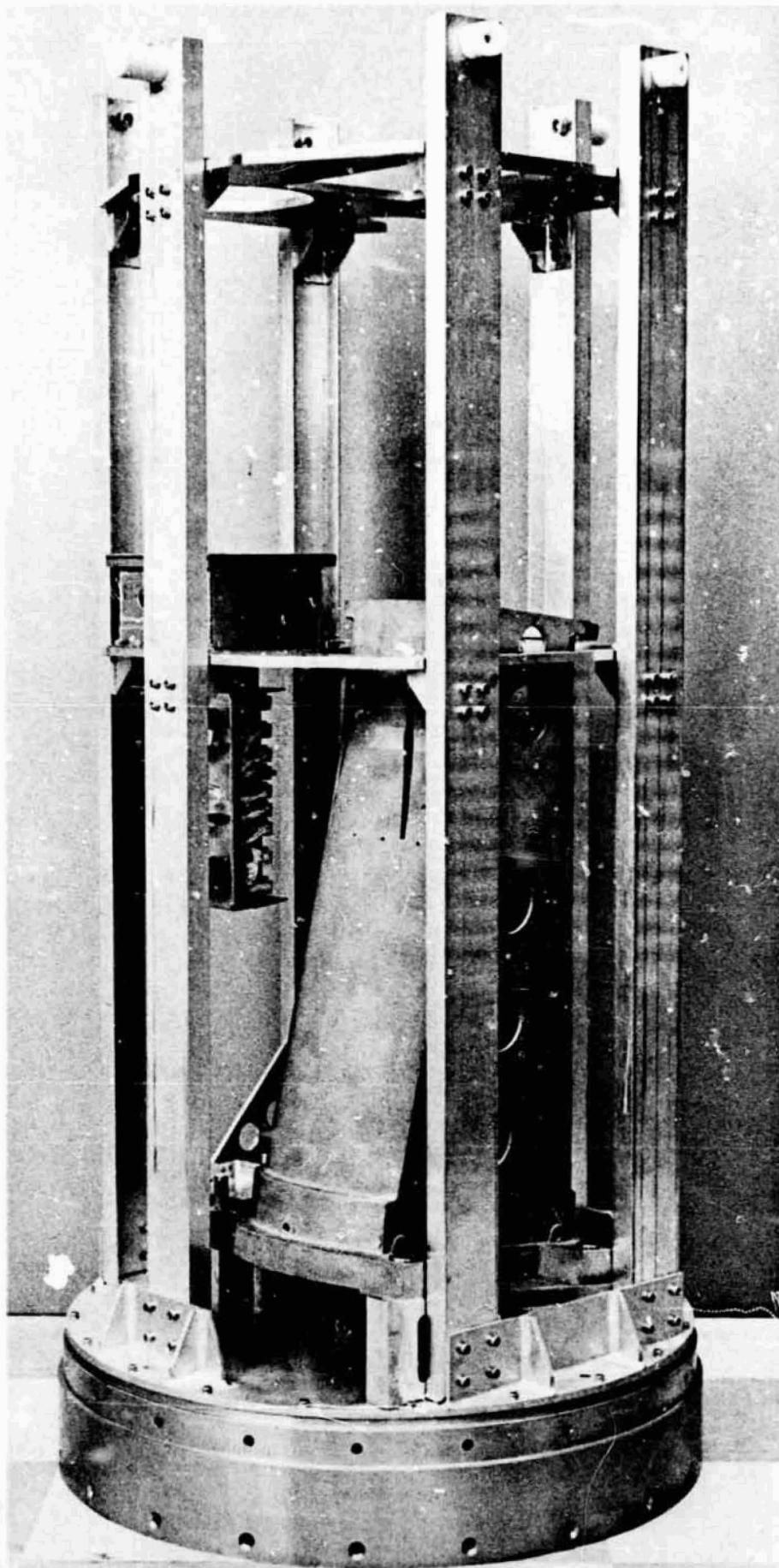

PLATE OVER  
GOUGED HOLES



**APPENDIX B**

**PHOTOGRAPHS OF INSTRUMENT PARTS, SUBASSEMBLIES  
AND ROCKET INSTALLATION**



17. 11  
Fig 1-1  
UVS Housing in  
Rocket Frame

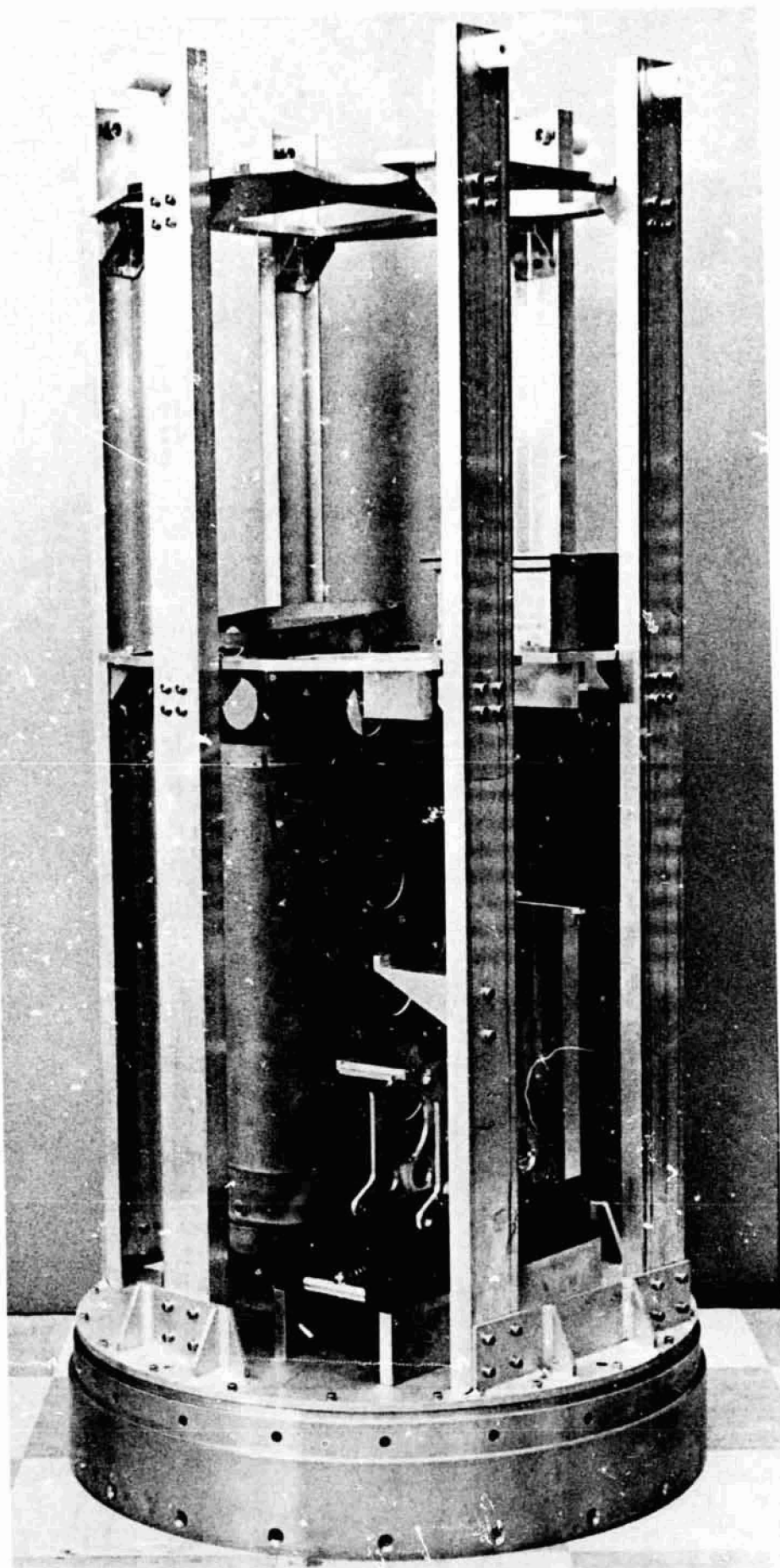

17.11  
Fig 1-2  
UVS Housing in  
Rocket Frame

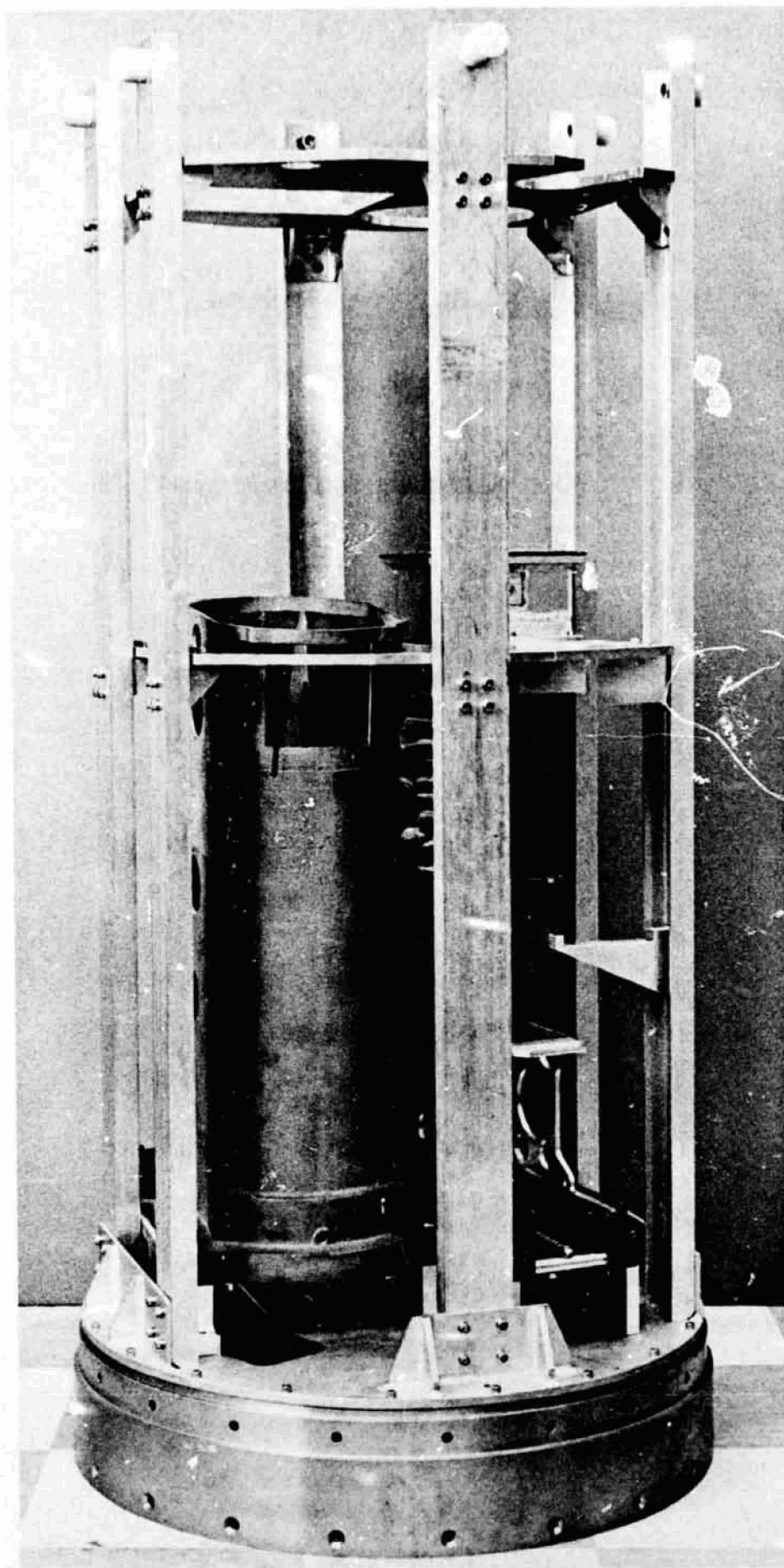

17. 11  
Fig 1-3  
UVS Housing in  
Rocket Frame

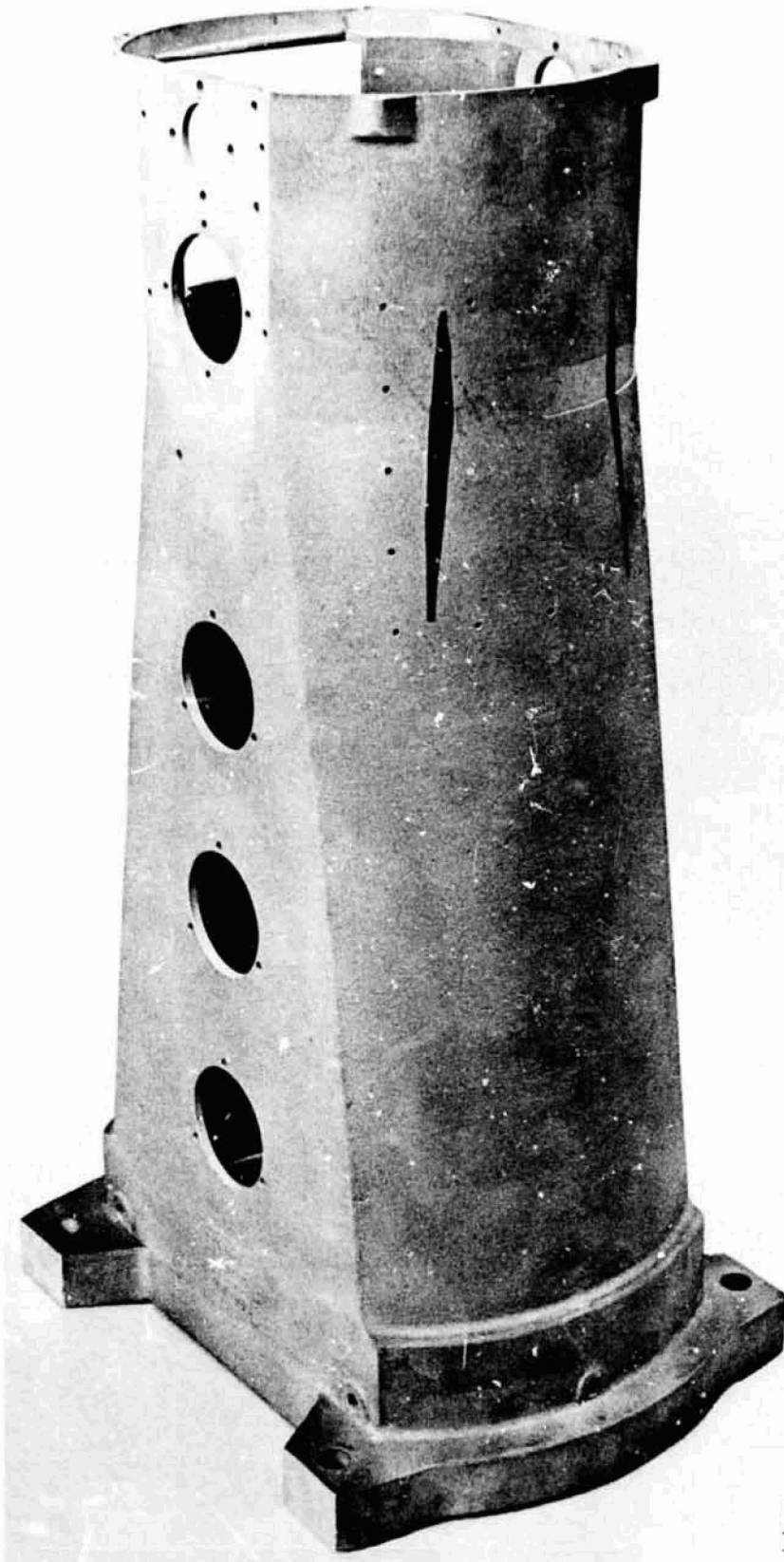

17.11  
Fig 2-1  
Housing

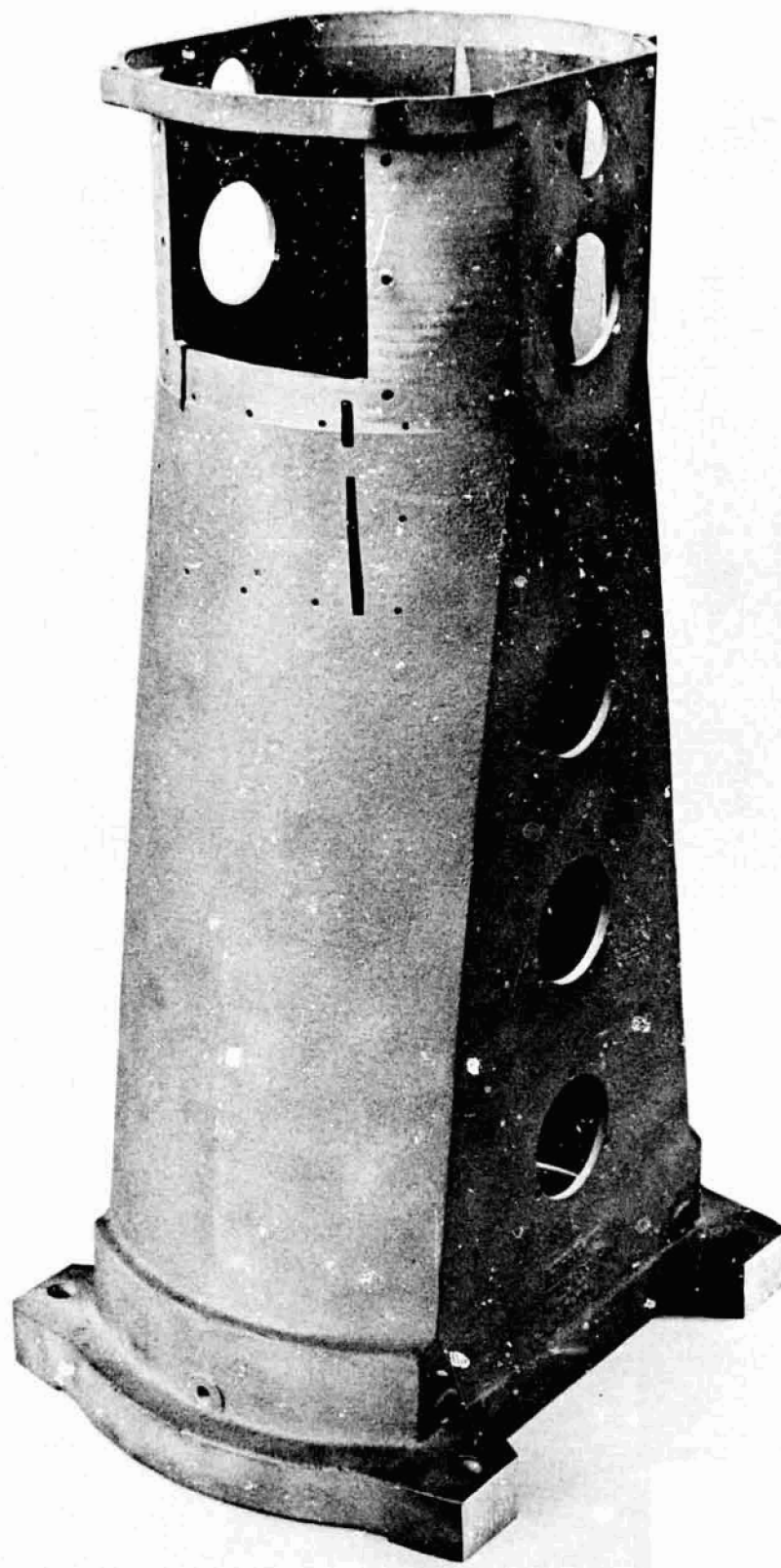

17. 1'  
Fig 2-2  
Housing

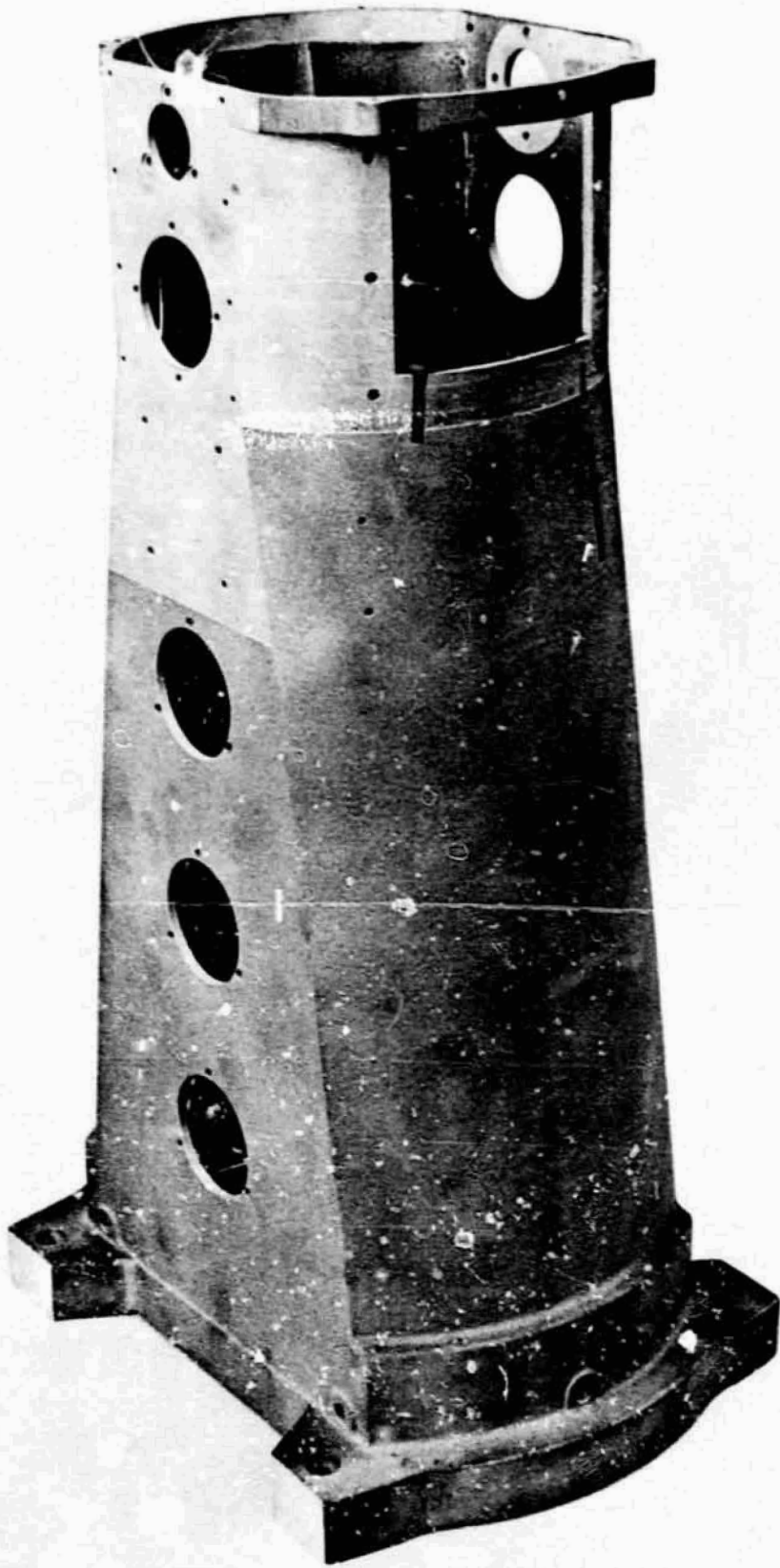

17. 11  
Fig 2-3  
Housing

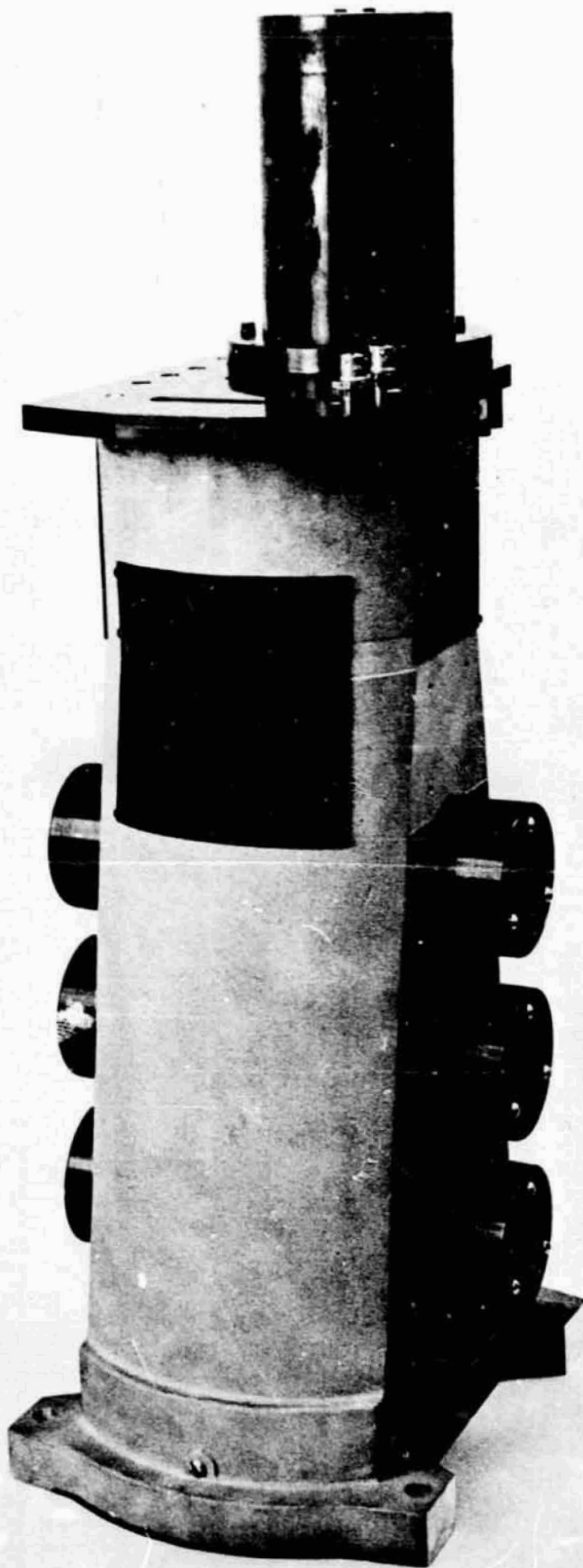

17.11  
Fig 3-1  
Housing with  
Detector Head



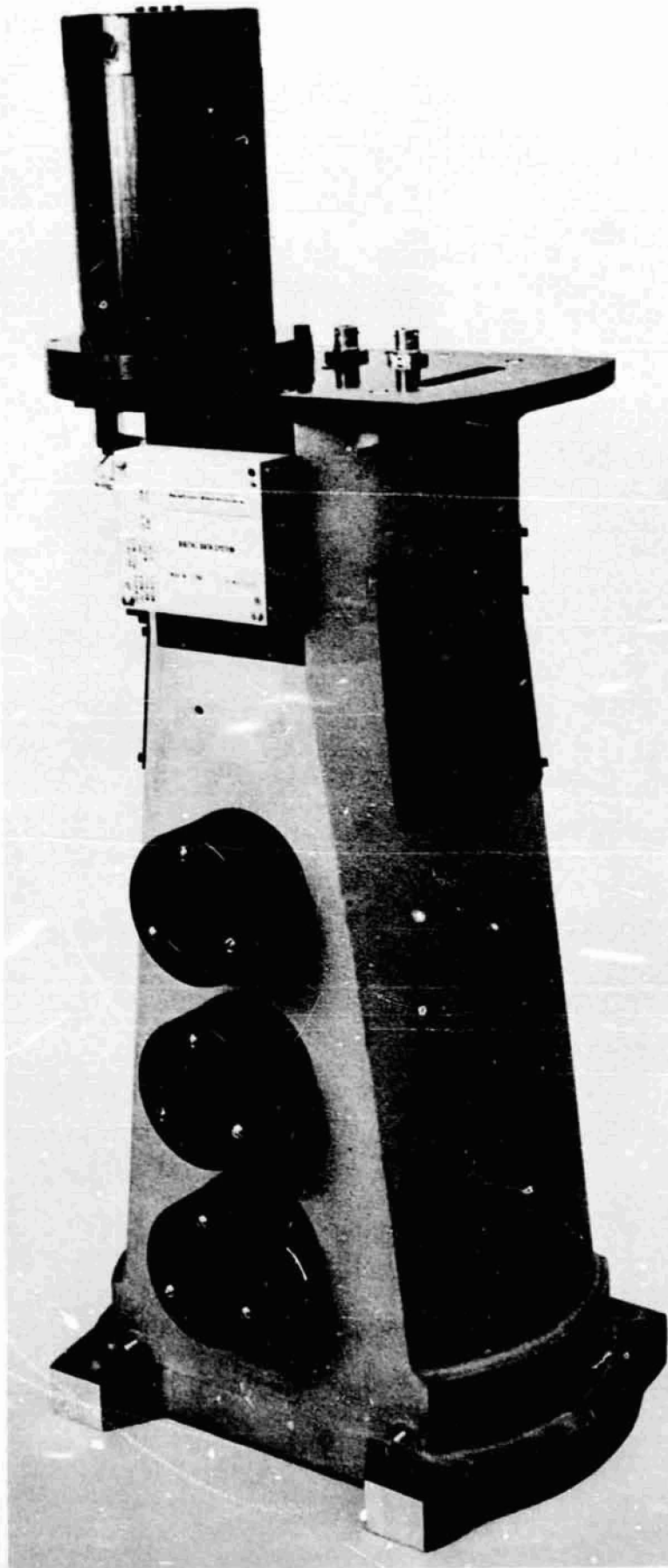

17.11  
Fig 4-1  
Housing with  
Data Module

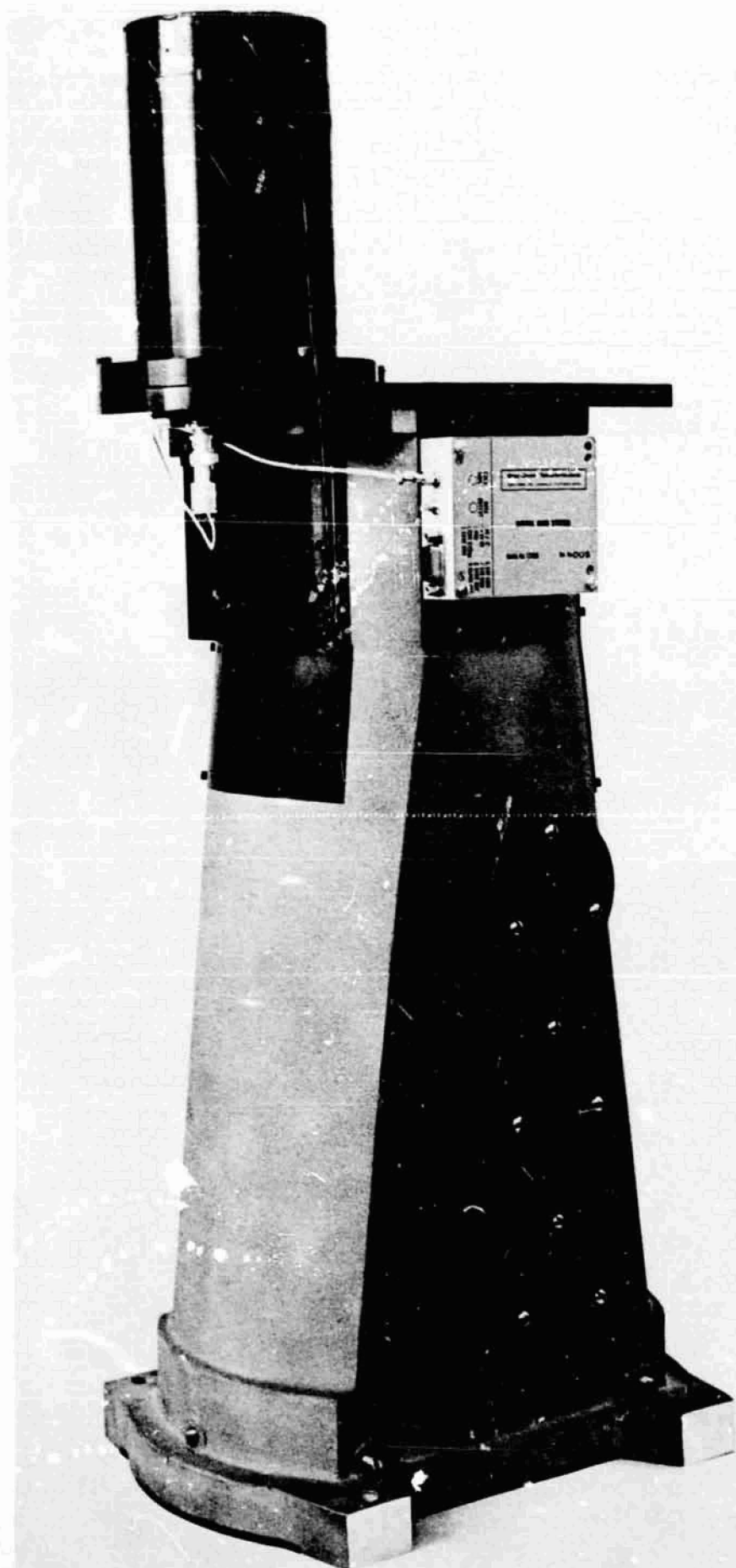

17.11  
Fig 4-2  
Housing with  
Data Module

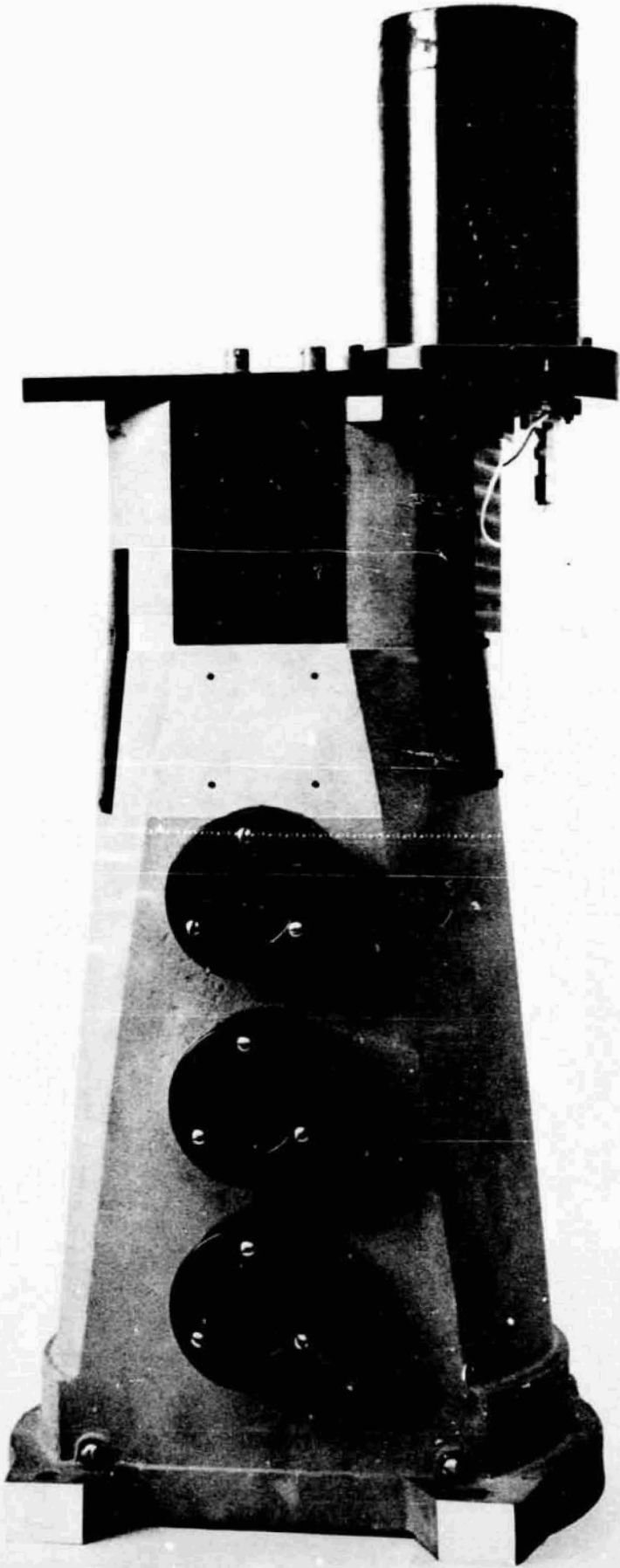

17. 11  
Fig 4-3  
Housing with  
Data Module

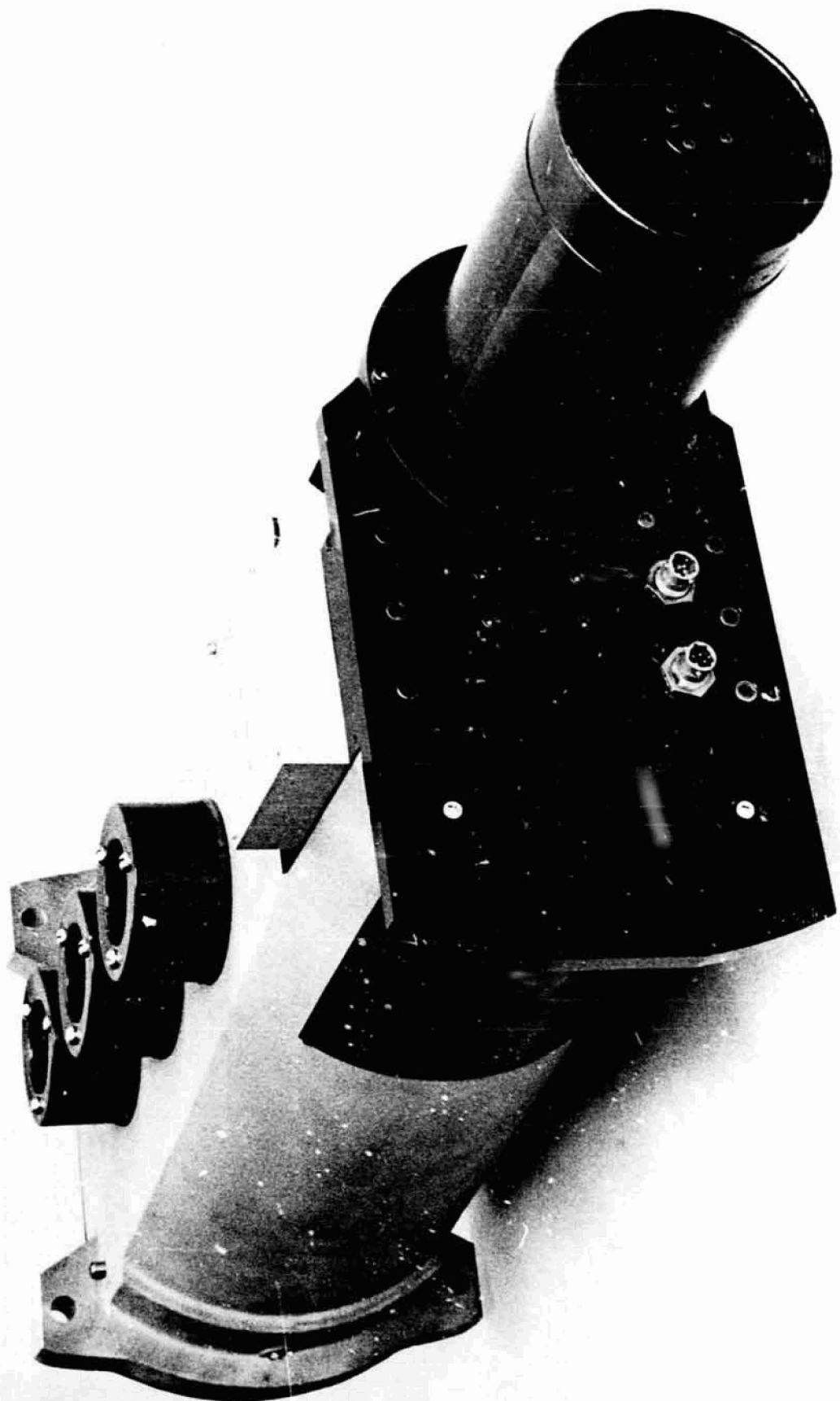

17. 11  
Fig 4-4  
Housing with  
Data Module

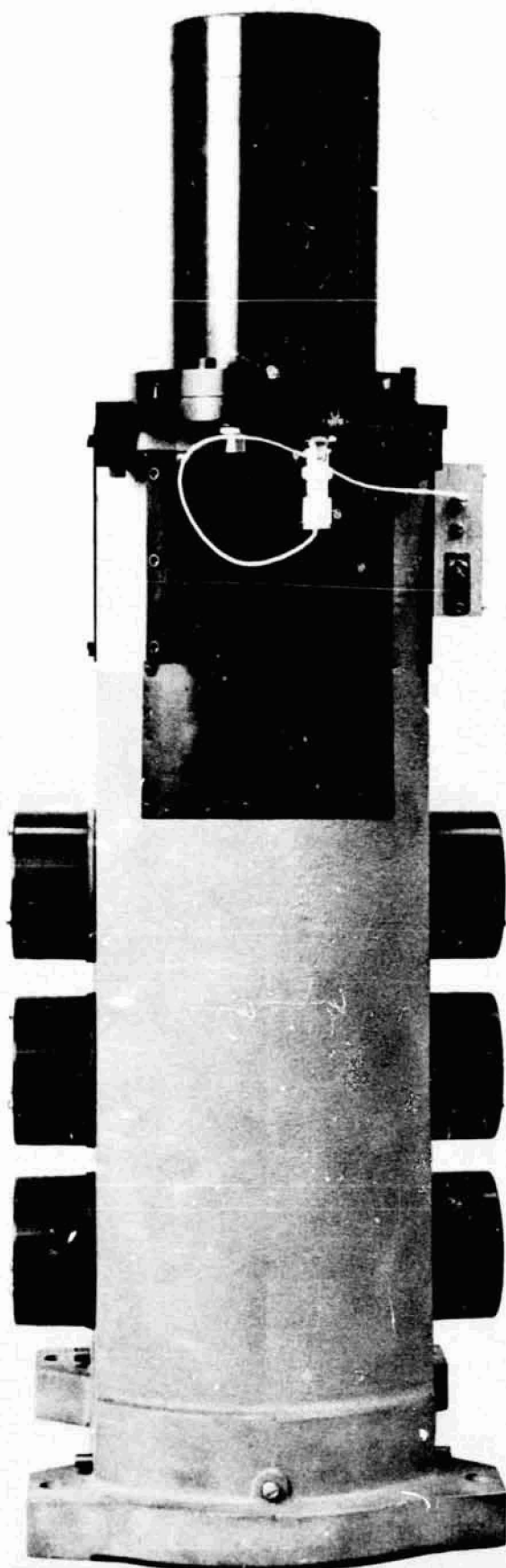

17. 11  
Fig 4-5  
Housing with  
Data Module



17.11  
Fig 5-1  
Detector Components  
and Data Module

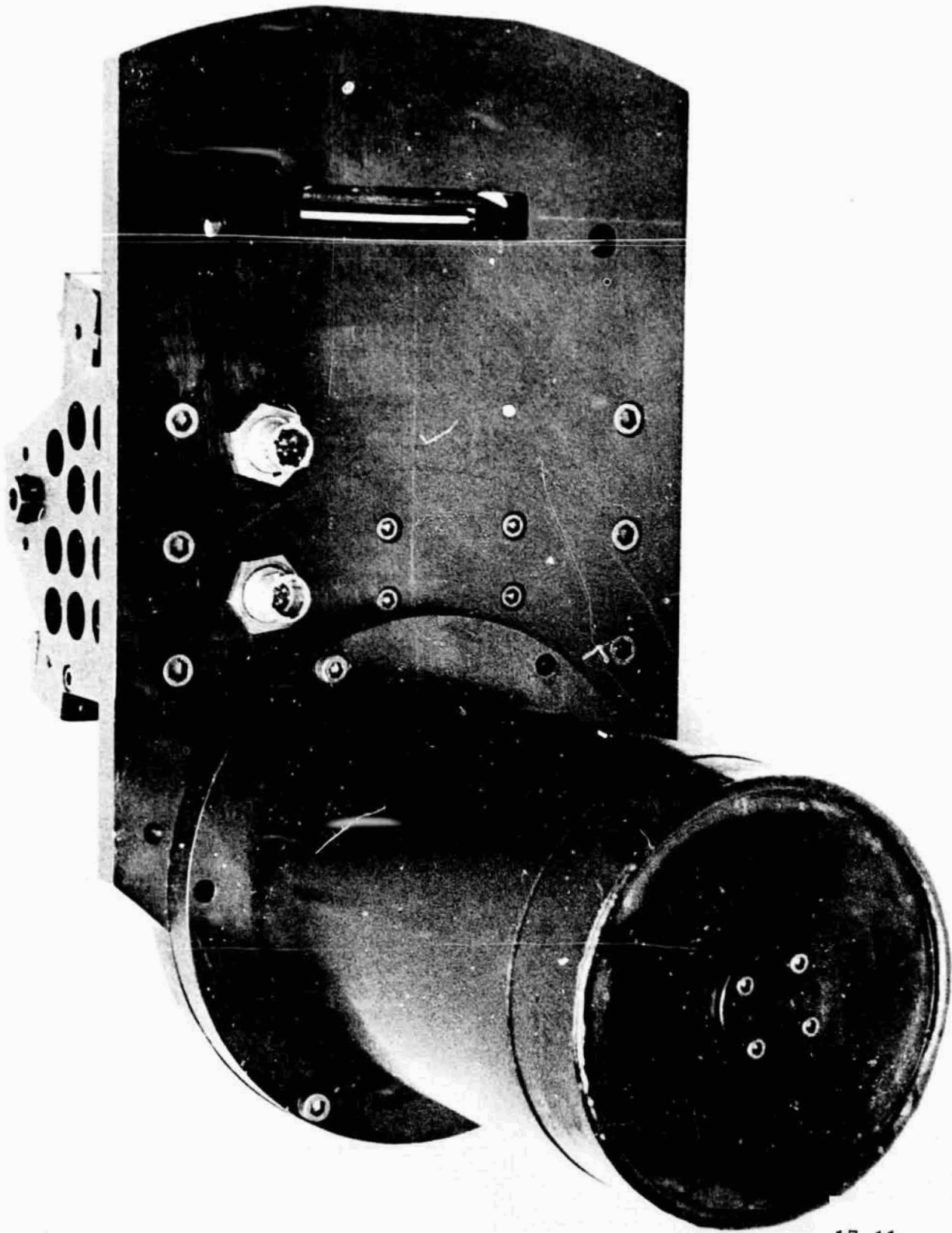

17. 11  
Fig 6-1  
Detector and Slit  
Plate Assembly

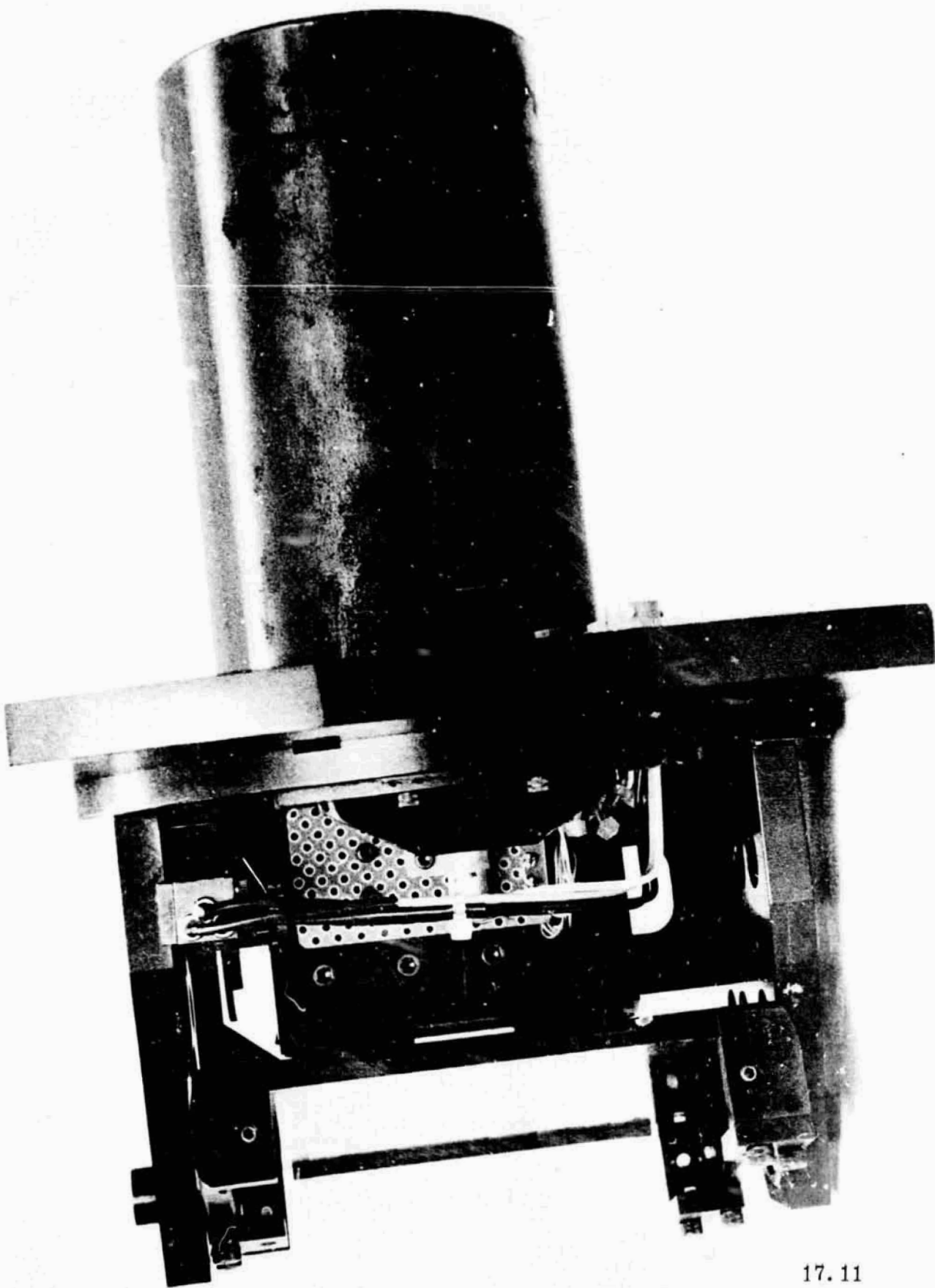

17. 11  
Fig 6-2  
Detector and Slit  
Plate Assembly



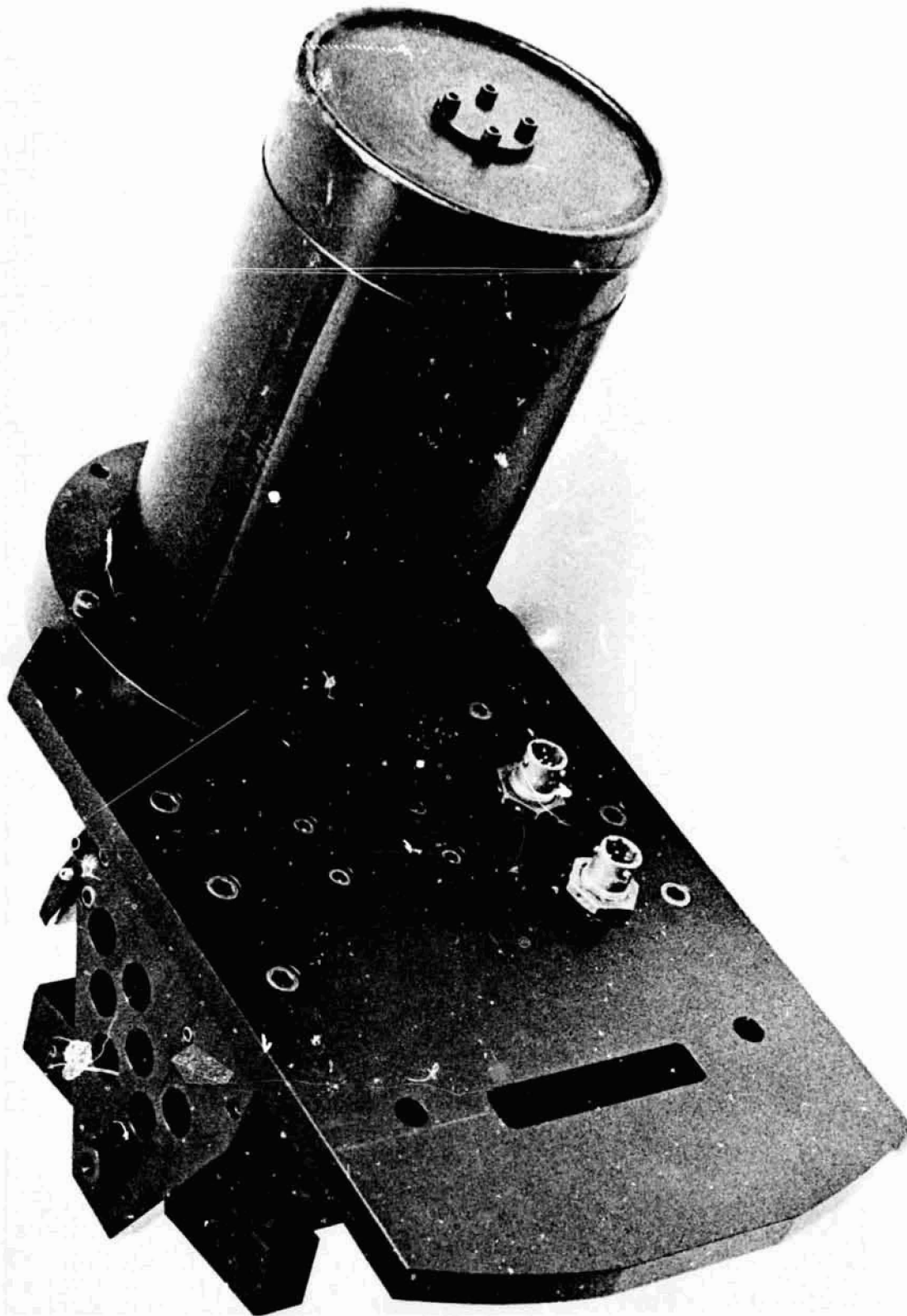

17. 11  
Fig 6-3  
Detector and Slit  
Plate Assembly



17. 11  
Fig 6-4  
Detector and Slit  
Plate Assembly

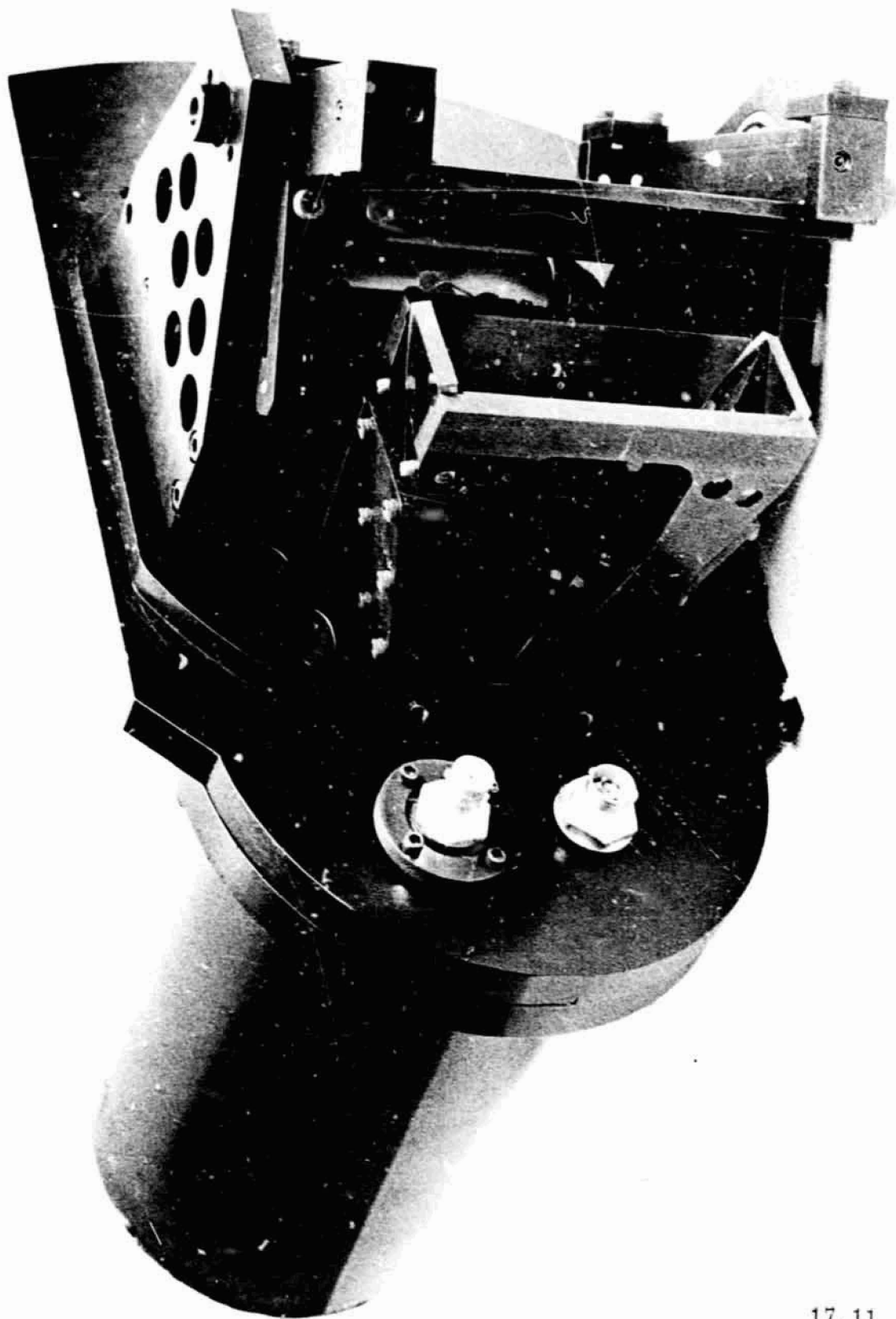

17. 11  
Fig 6-5  
Detector and Slit  
Plate Assembly

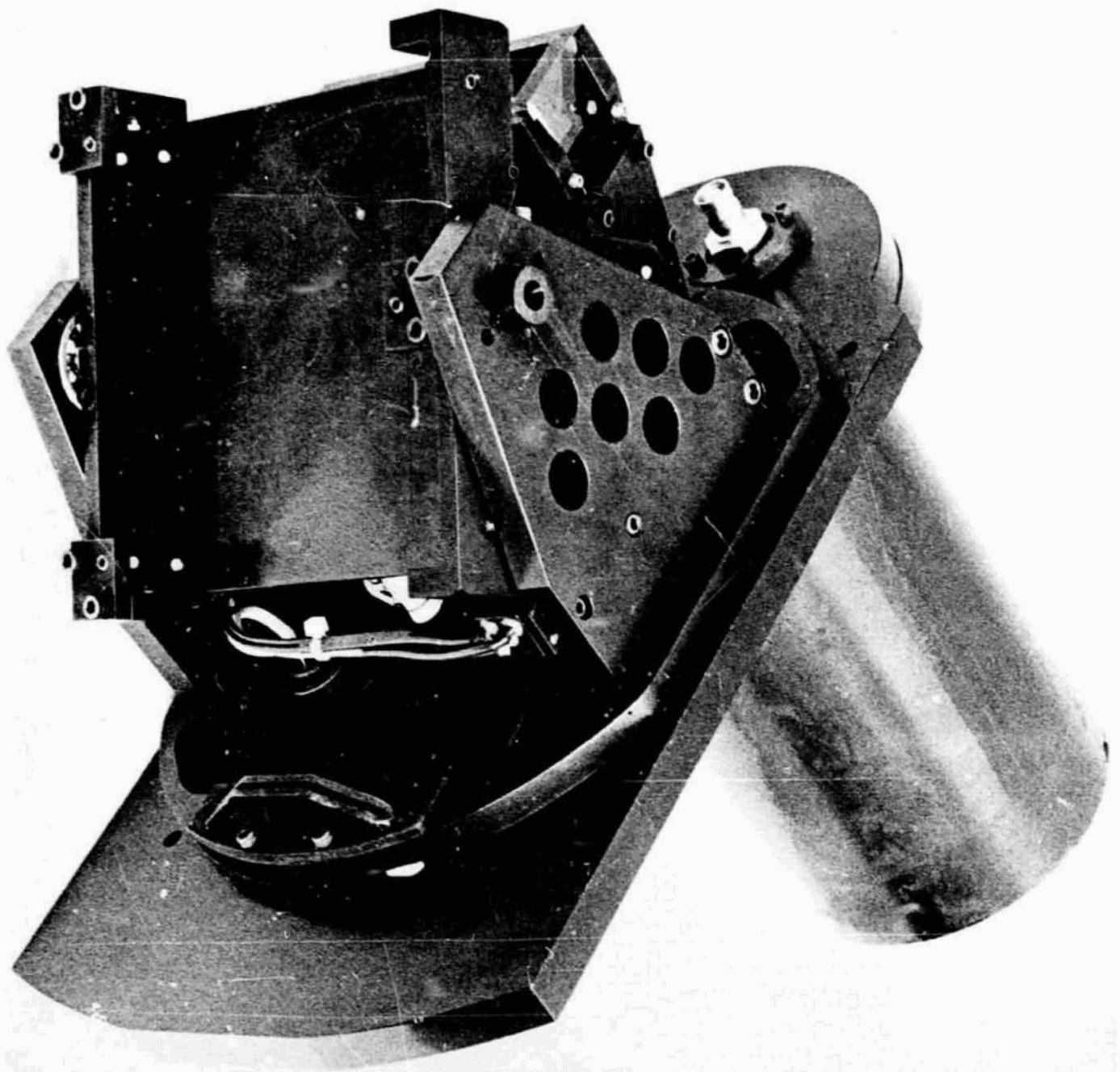

17. 11  
Fig 6-6  
Detector and Slit  
Plate Assembly

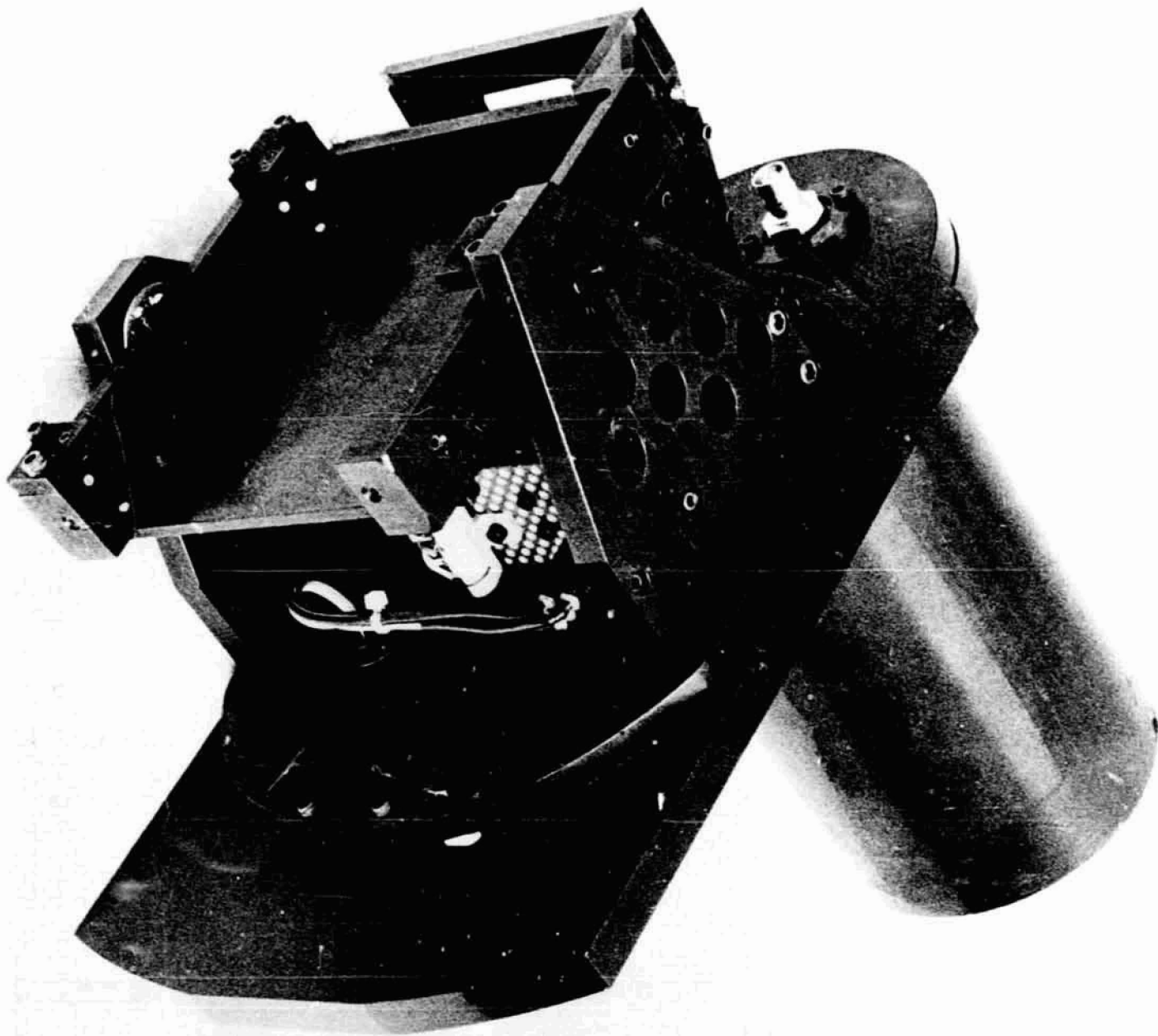

17. 11  
Fig 6-7  
Detector and Slit  
Plate Assembly

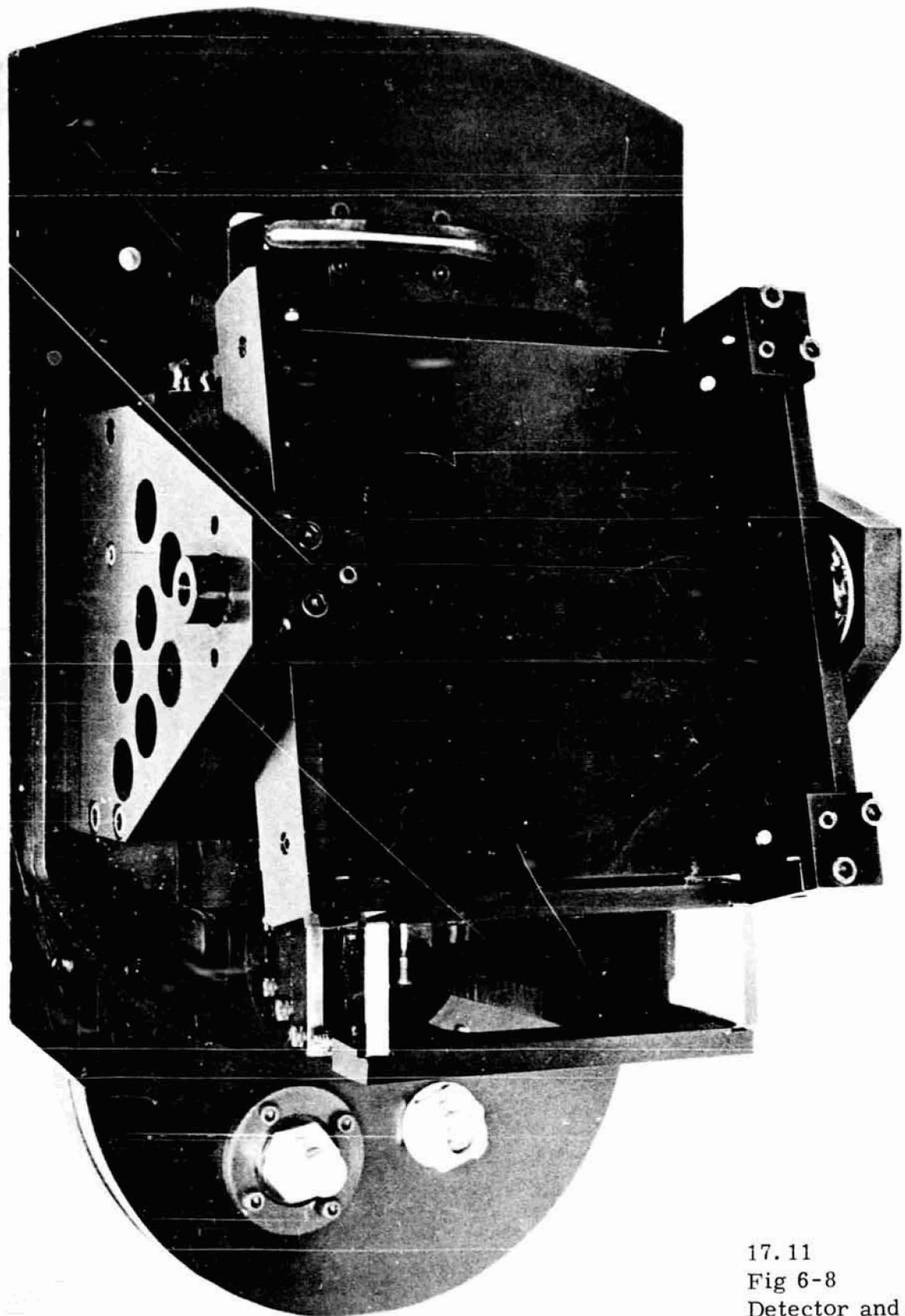

17.11  
Fig 6-8  
Detector and Slit  
Plate Assembly

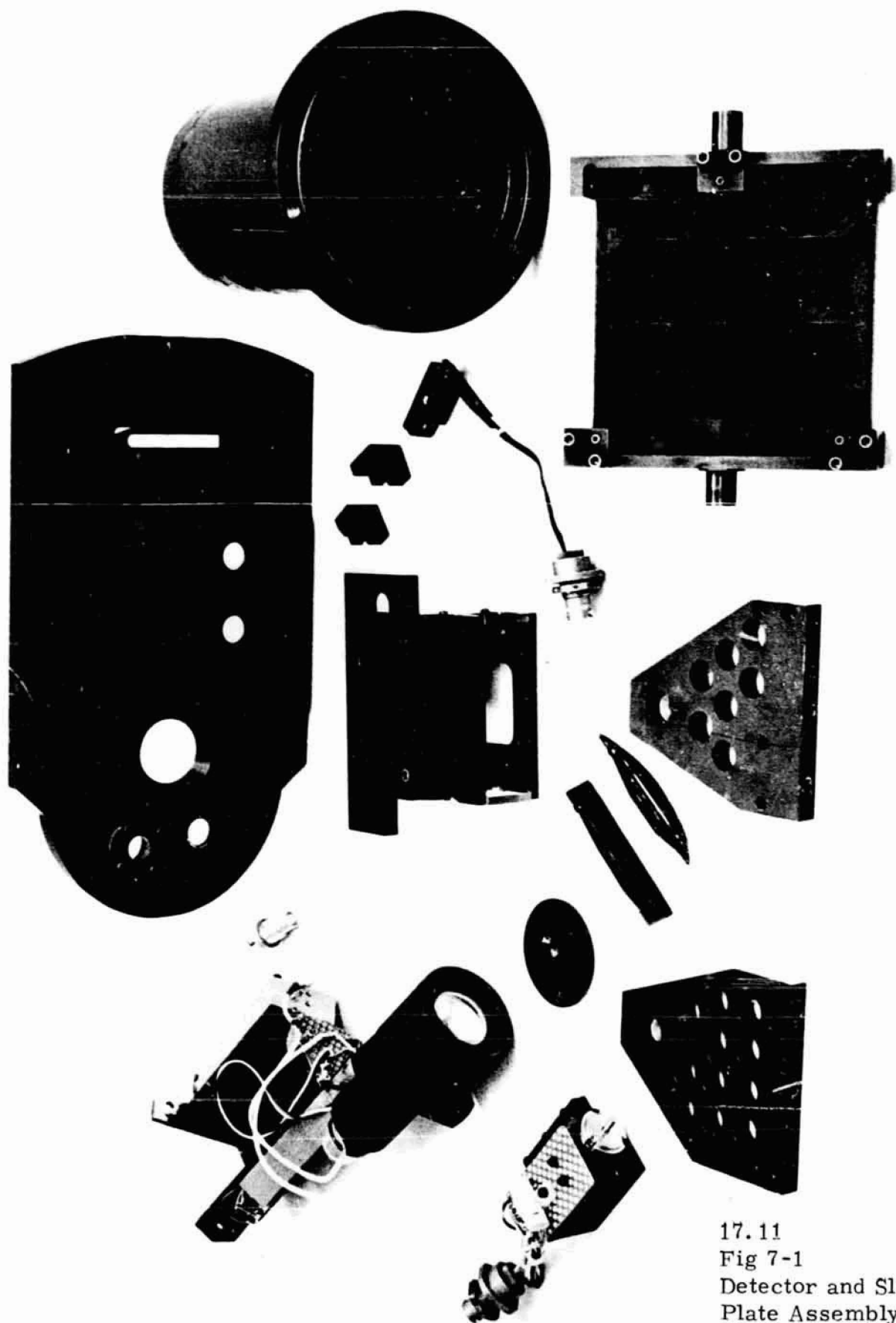

17.11  
Fig 7-1  
Detector and Slit  
Plate Assembly  
Components

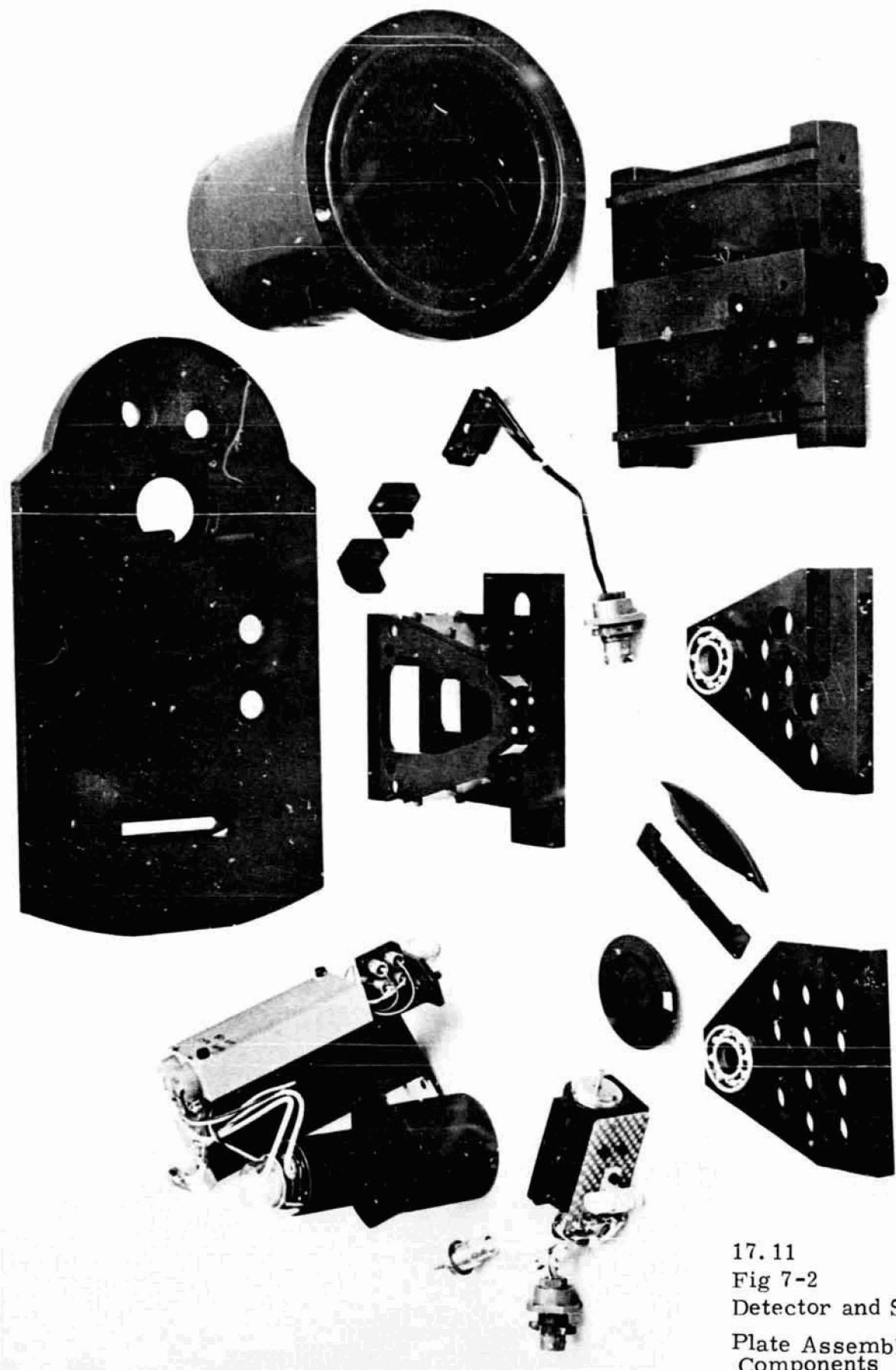

17. 11  
Fig 7-2  
Detector and Slit  
Plate Assembly  
Components



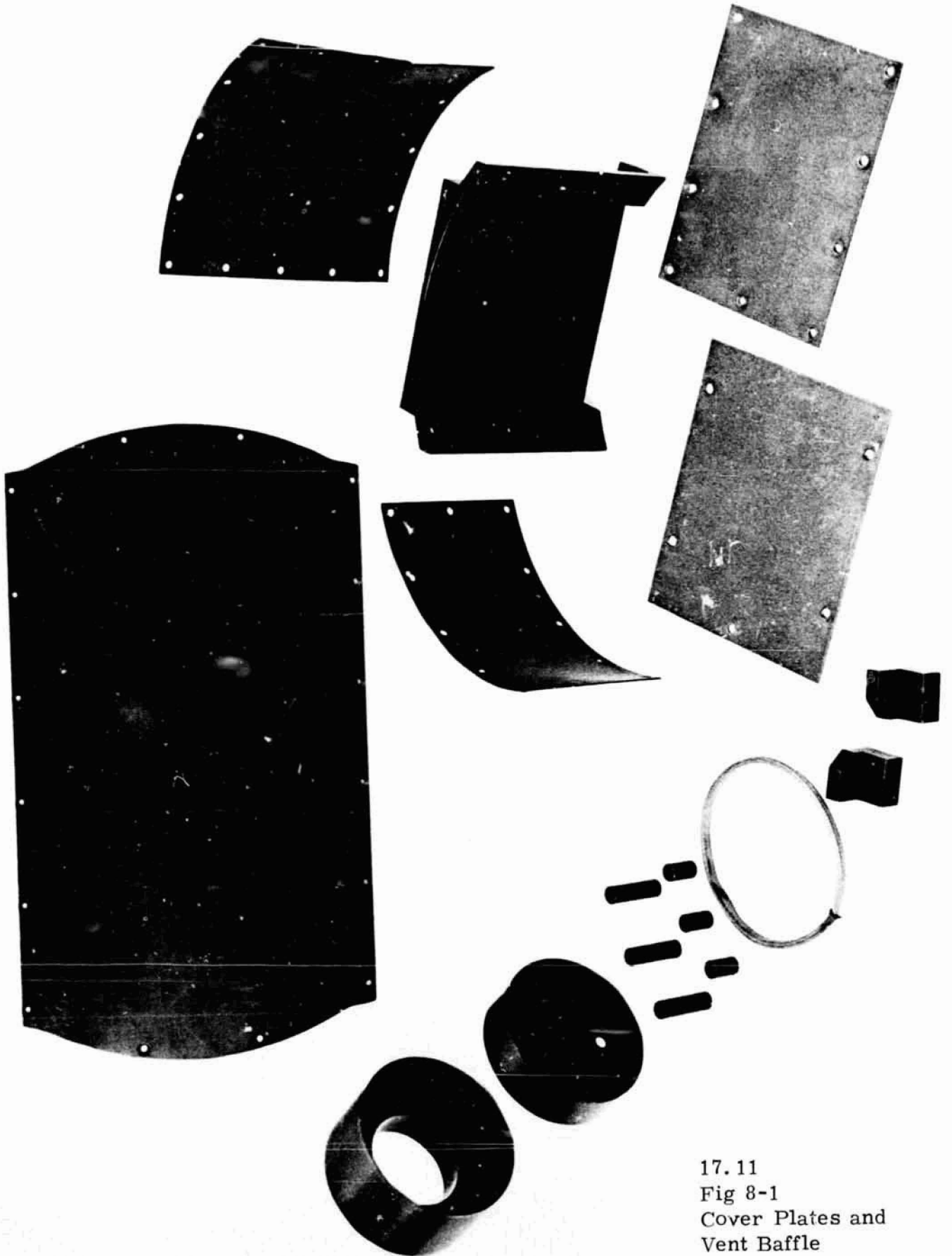

17.11  
Fig 8-1  
Cover Plates and  
Vent Baffle  
Components



17.11  
Fig. 9-1  
UVS Entrance  
Slit Baffle

**APPENDIX C**

**AEROBEE 350 FLIGHT ACCEPTANCE**

**VIBRATION SPECIFICATIONS**

<b>TEST ACTION REQUEST</b>		No. <b>19380</b>	
PROJECT DESIGNATION <b>SOUNDING ROCKETS</b>		GSFC JOB ORDER NO. <b>879-24-25-88</b>	T&E NO. <b>3-A</b>
ISSUE DATE <b>Feb. 10, 1971</b>		RE-TEST <input type="checkbox"/>	
ITEM IDENTIFICATION <b>17.11 Payload</b>		NO. OF ITEMS <b>1</b>	WILL 324 MONITOR <input type="checkbox"/> Yes <input checked="" type="checkbox"/> No
MODEL		GSFC PART NO. AND/OR SERIAL NO.	ITEM DESCRIPTION
TEST CATEGORY		WEIGHT SIZE COST	
TEST CATEGORY <input checked="" type="checkbox"/> A. Vib. <input type="checkbox"/> E. Op. Spin <input type="checkbox"/> N. Sol-Vac <input type="checkbox"/> B. Shock <input type="checkbox"/> F. Balance <input type="checkbox"/> J. Leak <input type="checkbox"/> C. Accel. <input type="checkbox"/> G. Wt. & CG <input type="checkbox"/> K. Temp. <input type="checkbox"/> D. Load <input type="checkbox"/> H. MI <input type="checkbox"/> L. Humidity <input type="checkbox"/> M. Therm-Vac			
REFERENCES		REMARKS	
S-20-SR-2			
Test Specification			
Test Plan/Other			
Test Procedure			
NOTES			
Aerobee 350 flight specs, 3 axes, sine and random <b>STANDARD INSTRUMENTATION: Pdk</b>			
DATE ITEM AVAILABLE <b>3/15/71</b> DATE SCHEDULED From: <b>5/13</b> To: DATE TEST STARTED <b>5/14/71</b> DATE TEST COMPLETED <b>5/14/71</b>		EQUIPMENT USED <b>5967</b> NO. OF SETUPS <b>7 RUNS</b>	
PLANNED EQUIPMENT OR FACILITY PREFERRED <b>Lipiner</b> 5967 ALTERNATE <b>Demas/Kinsley</b> 4186 T&E PROJECT ENGINEER <b>Sweet</b> 5468 T&E SUPPORT MANAGER		TEST STATUS Satisfactory <input checked="" type="checkbox"/> Discrepancy Noted <input type="checkbox"/> Unsatisfactory <input type="checkbox"/> (See Report) Retest Required <input type="checkbox"/>	
TEST ITEM RETURNED TO DATE TEST COMPLETED <b>5/14/71</b>		Winzor Ext. 5966	
REPORTS REQUIRED			
None <input type="checkbox"/> Test Digest <input type="checkbox"/> Final Report <input type="checkbox"/> Assigned No. _____		Other (Specify) <input type="checkbox"/>	

PROCESSED BY  
 DATA CENTRAL  
 DATE \_\_\_\_\_  
 INITIALS: \_\_\_\_\_

STRUCTURAL DYNAMICS VIBRATION LABORATORY - GSFC

PROJECT S.R.K.T. AXIS LAT. 1 (X) OPERATOR E.K.  
ITEM 17.11 DATE 5/14/71  
PAYLOAD

EXCITER # 4 MODEL N° \_\_\_\_\_  
FIXTURE \_\_\_\_\_ SER N° 17.11  
SWEEP RATE 4 Oct/min. TAR N° 19380

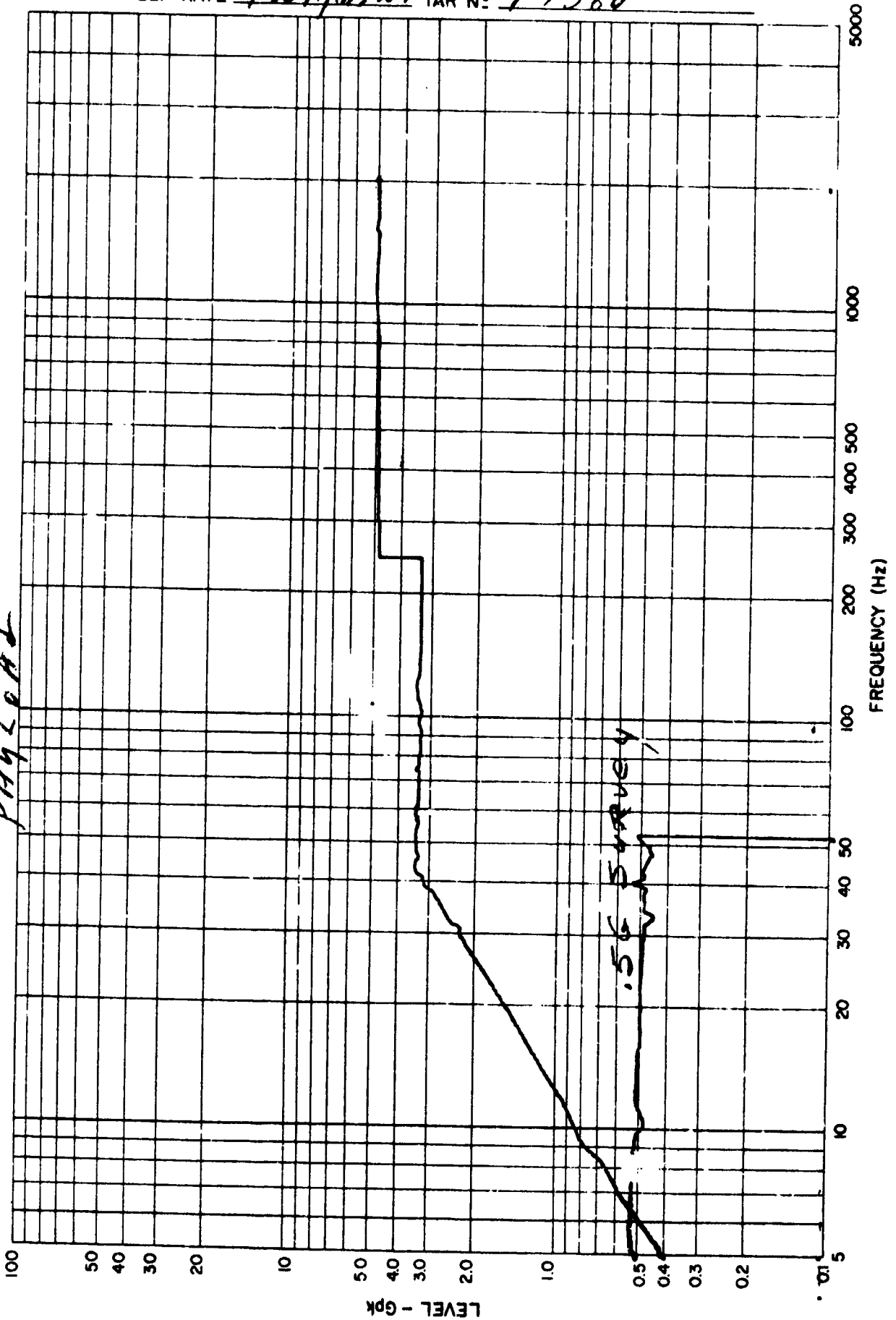

STRUCTURAL DYNAMICS VIBRATION LABORATORY - GSFC

PROJECT S.R.K.T. AXIS Y OPERATOR E.R.  
ITEM 17.11 DATE 5/14/71

PAYLOAD

EXCITER # 4 MODEL N° \_\_\_\_\_  
FIXTURE \_\_\_\_\_ SER N° 17.11  
SWEEP RATE 4 OCT./MIN TAR N° 19380

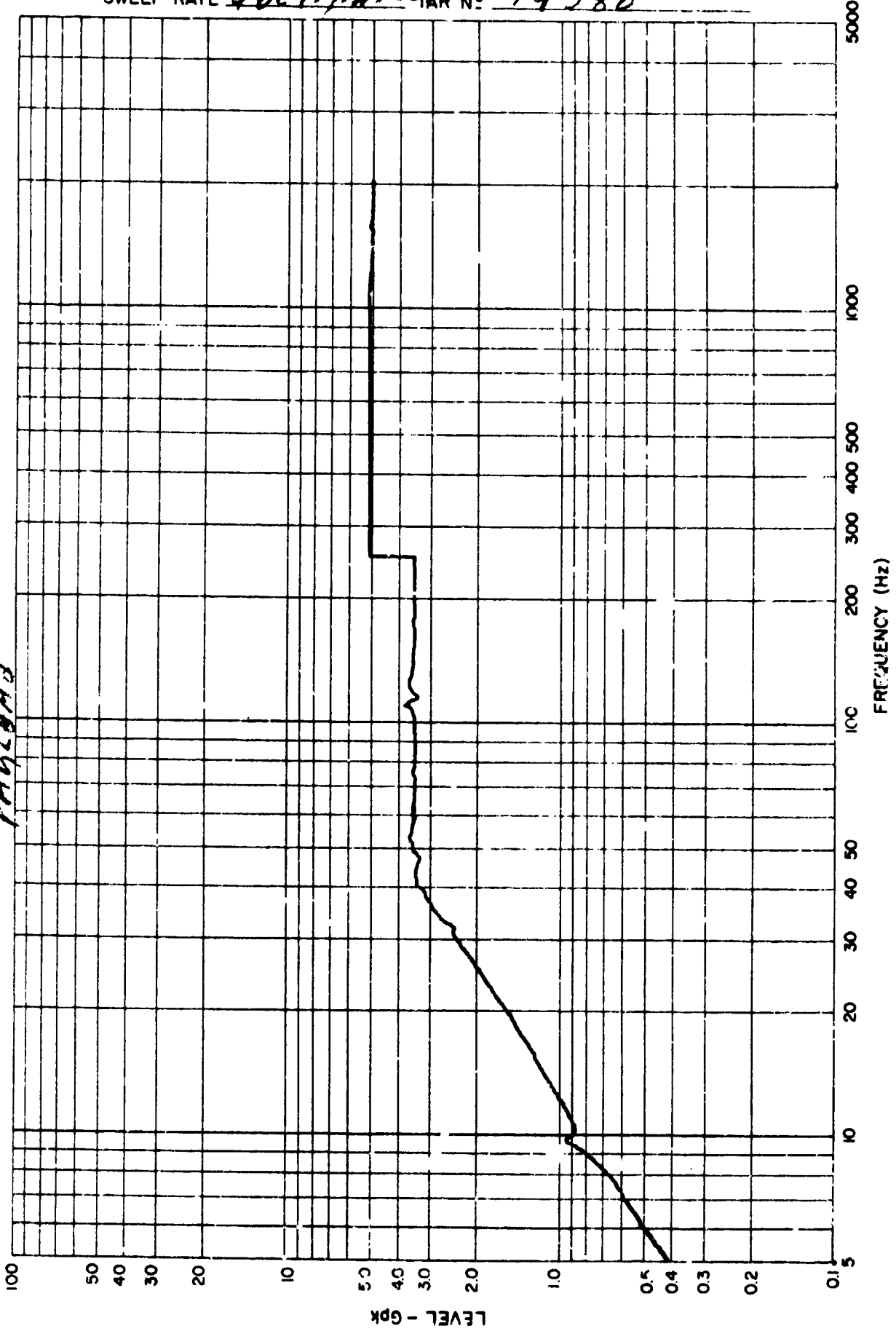

STRUCTURAL DYNAMICS VIBRATION LABORATORY - GSFC

PROJECT S. RKT. AXIS Y-R457 OPERATOR E. ZL  
ITEM 17.11 DATE 5/14/71  
PAYLOAD

EXCITER A4 MODEL NO \_\_\_\_\_  
FIXTURE \_\_\_\_\_ SER NO 17.11  
SWEEP RATE 4 OCT. MIN. TAR NO 19380

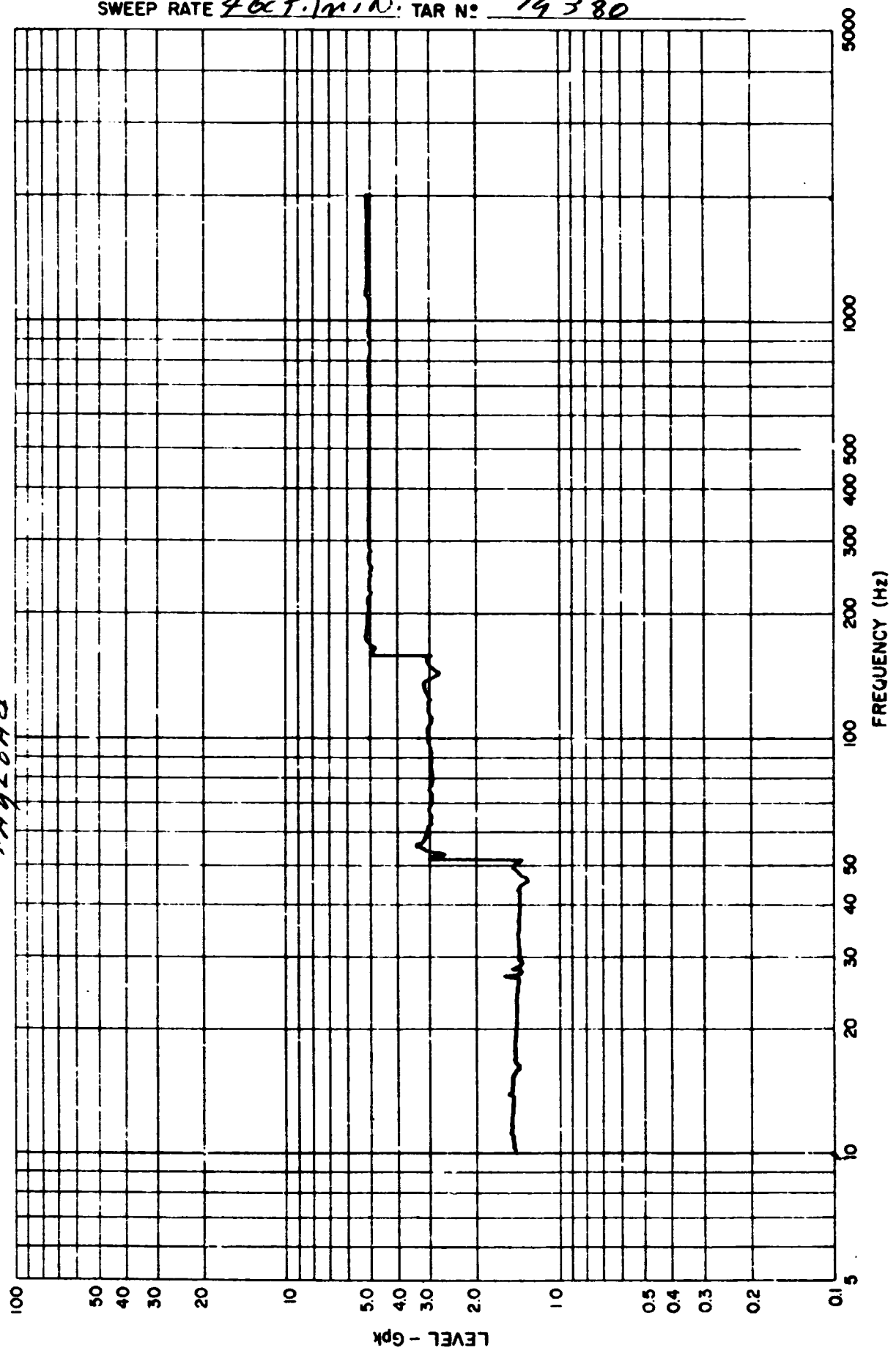

**SUMMARY OF ENVIRONMENTAL TEST  
PARAMETERS FOR SOUNDING ROCKET  
PAYLOADS**

TEST/PROCEDURE (In Normal Sequence)	AEROBEE 150-150A		AEROBEE 350	
	DESIGN QUALIFICATION	FLIGHT ACCEPTANCE	DESIGN QUALIFICATION	FLIGHT ACCEPTANCE
<b>LEAK DETECTION</b> Chamber Pressure Maximum Leak Rate	$1 \times 10^{-4}$ mm Hg $1 \times 10^{-4}$ atm-sec/lb./sec	Same as Prototype	Same as Aerobee 150-150A	Same as Aerobee 150-150A
<b>BALANCE</b> (Thrust Axis) 1. STATIC 2. DYNAMIC	8 oz. in. 200 oz./in. <sup>2</sup>	8 oz. in. 100 oz./in. <sup>2</sup>	8 oz. in. 200 oz./in. <sup>2</sup>	4 oz. in. 100 oz./in. <sup>2</sup>
<b>PHYSICAL MEASUREMENTS</b> 1. WEIGHT 100 lbs. 100 lbs. 2. CENTER OF GRAVITY (along thrust axis) 3. MOMENT OF INERTIA (spin & pitch axes)	0.2 lb. 0.2 % 0.125 in. $0.04 \text{ slug ft}^2$ or 1.0 % whichever greater	Same as Prototype	Same as Aerobee 150-150A	Same as Aerobee 150-150A
<b>SPIN</b> Rate Duration	162 rpm 5 minutes	112 rpm 5 minutes	162 rpm 5 minutes	172 rpm 5 minutes
<b>TEMPERATURE &amp; HUMIDITY</b> 1. STORAGE TEMPERATURE Hot Cold 2. HUMIDITY Stabilized Temperature Relative Humidity Duration 3. OPERATIONAL TEMPERATURE a. Hot Conditioning Non-operating Stabilized Temp. Post-stabilized Exposure b. Cold Conditioning Non-operating Stabilized Temp. Post-stabilized Exposure	60°C for 6 hrs. -30°C for 6 hrs. 30°C 95% 24 hrs Predicted launch site extreme 6 hrs. Predicted launch site extreme 6 hrs.	Same as Prototype	Same as Aerobee 150-150A	Same as Aerobee 150-150A
<b>VIBRATION</b> 1. SINUSOIDAL Sweep rate Thrust (z-z axis) levels  Lateral (x-x and y-y) levels  2. RANDOM Duration Thrust (z-z axis) levels  Lateral (x-x and y-y) levels  Acceleration Thrust Lateral 3. OTHER VIBRATION REQUIREMENTS (if any)	2 octaves per min. 2.3 g 4.5 g 7.5 g  5.4 in./sec constant velocity 5.3 g 7.5 g 20 sec. per axis 0.056 g <sup>2</sup> /Hz  0.113 g <sup>2</sup> /Hz  10.5 g-rms 15.0 g-rms	10-60 Hz 60-160 160-2000  10-60 Hz 60-250 250-2000  20-2000 Hz  20-2000 Hz  7.0 g-rms 10.0 g-rms	4 octaves per min. 1.5 g 3.0 g 5.0 g  3.6 in./sec constant velocity 3.5 g 5.0 g 10 sec per axis 0.025 g <sup>2</sup> /Hz  0.050 g <sup>2</sup> /Hz  7.0 g-rms 10.0 g-rms	2 octaves per min. 2.3 g 4.5 g 7.5 g  7.7 in./sec constant velocity 5.3 g 7.5 g 20 sec per axis 0.056 g <sup>2</sup> /Hz  20-2000 Hz  10.5 g-rms 15.0 g-rms
<b>ACCELERATION</b> Duration Thrust axis (z-z) only	1/2 min. 1.5 times predicted magnitude (g's)	Not Required	1/2 min. 1.5 times predicted magnitude (g's)	Not Required
<b>THERMAL-VACUUM</b> (Chamber Conditions) 1. CORONA CHECK Pressure Temperature Duration 2. HIGH TEMPERATURE Pressure Temperature Duration 3. LOW TEMPERATURE Pressure Temperature Duration	ambient to $1 \times 10^{-4}$ mm Hg ambient launch pressure vs time profile  $1 \times 10^{-4}$ mm Hg 10°C above predicted extreme 2 hours  $1 \times 10^{-4}$ mm Hg 10°C below predicted extreme 2 hours	Same as Prototype  Same as prototype Predicted hot extreme  Same as prototype  Same as prototype Predicted cold extreme  Same as prototype	Same as Aerobee 150-150A	Same as Aerobee 150-150A