

17

T.M. R. Smith

089C 20-1-F

THE UNIVERSITY OF MICHIGAN

COLLEGE OF ENGINEERING
DEPARTMENT OF ELECTRICAL AND COMPUTER ENGINEERING
SPACE PHYSICS RESEARCH LABORATORY

Sounding Rocket Flight Report

MUMP 9 and MUMP 10

Reproduced by
NATIONAL TECHNICAL
INFORMATION SERVICE
U S Department of Commerce
Springfield VA 22151

Prepared on behalf of the project by
H. J. GRASSL

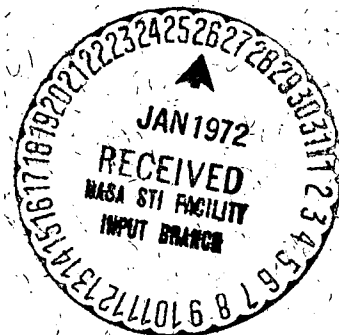

~~123557~~

(SESSION NUMBER) _____ (TITLE)
(NASA-CR-~~123557~~) SOUNDING ROCKET FLIGHT
REPORT, MUMP 9 AND MUMP 10 H.J. Grassl
(Michigan Univ.) Nov. 1971 56 p CSCL 16B

N72-20793

Unclas
G3/3G 15121

Under contract with:

National Aeronautics and Space Administration
George C. Marshall Space Flight Center
Contract No. NAS8-21086
Huntsville, Alabama

Administered through:

November 1971

35A

THE UNIVERSITY OF MICHIGAN
COLLEGE OF ENGINEERING
Department of Electrical & Computer Engineering
Space Physics Research Laboratory

Sounding Rocket Flight Report

MUMP 9 and MUMP 10

Prepared on behalf of the project by

H. J. Grassl

ORA Project 089020

under contract with:

NATIONAL AERONAUTICS AND SPACE ADMINISTRATION
GEORGE C. MARSHALL SPACE FLIGHT CENTER
CONTRACT NO. NAS8-21086
HUNTSVILLE, ALABAMA

administered through:

OFFICE OF RESEARCH ADMINISTRATION ANN ARBOR

November 1971

PRECEDING PAGE BLANK NOT FILMED

TABLE OF CONTENTS

| | Page |
|---|------|
| ACKNOWLEDGMENTS | iv |
| LIST OF ILLUSTRATIONS | v |
| 1. INTRODUCTION | 1 |
| 2. GENERAL FLIGHT INFORMATION | 2 |
| 3. LAUNCH VEHICLE | 4 |
| 4. NOSE CONE | 8 |
| 5. THE THERMOSPHERE PROBE | 12 |
| 5.1. Omegatron | 12 |
| 5.2. Electron Temperature and Density Probe | 20 |
| 5.3. Support Measurements and Instrumentation | 23 |
| 5.3.1. Aspect determination system | 23 |
| 5.3.2. Telemetry | 26 |
| 5.3.3. Housekeeping monitors | 27 |
| 6. ANALYSIS OF DATA | 29 |
| 6.1. Trajectory and Aspect | 29 |
| 6.2. Ambient N ₂ Density | 32 |
| 6.3. Neutral Particle Temperature | 42 |
| 6.4. Electron Temperature and Density | 42 |
| 6.5. Geophysical Indices | 42 |
| 7. REFERENCES | 49 |

ACKNOWLEDGMENTS

The MUMP launchings were conducted under Contract No. NAS8-21086. Over one hundred persons contributed to the success of MUMP 9 and MUMP 10; some of the personnel with specific responsibilities are listed below.

George C. Marshall Space Flight Center

| | |
|-----------------|----------------------|
| Ballance, J. O. | Experiment Physicist |
| Smith, R. E. | Project Scientist |
| Youngblood, W. | Experiment Engineer |

Space Physics Research Laboratory

| | |
|------------------|-------------------------------------|
| Carignan, G. R. | Laboratory Director |
| Taeusch, D. R. | Associate Laboratory Director |
| Caldwell, J. R. | Electronics Engineer |
| Campbell, B. J. | Design Draftsman |
| Cittadini, R. J. | Data Reduction Supervisor |
| Foust, E. C. | Head Programmer |
| Freed, P. L. | Head Technician |
| Kartlick, W. G. | Omegatron Technician |
| Kimble, R. G. | Telemetry Technician |
| Maurer, J. C. | Payload Engineer |
| McCormick, D. L. | Machinist |
| Phillips, D. C. | Electron Temperature Probe Engineer |

LIST OF ILLUSTRATIONS

| Table | Page |
|--|------|
| I. Table of Events | 3 |
| II. Omegatron Data | 16 |
| III. N ₂ Ambient Density Data | 40 |
| IV. Charged Particle Results | 46 |

| Figure | Page |
|---|------|
| 1. Nike-Tomahawk with thermosphere probe payload. | 5 |
| 2. Nike-Tomahawk dimensions, MUMP 9. | 6 |
| 3. Nike-Tomahawk dimensions, MUMP 10. | 7 |
| 4. MUMP 9 instrumentation design. | 9 |
| 5. MUMP 10 instrumentation design. | 10 |
| 6. Assembly drawing, 8-in. nose cone. | 11 |
| 7. MUMP 9 system block diagram. | 13 |
| 8. MUMP 10 system block diagram. | 14 |
| 9. Omegatron and breakoff configuration. | 15 |
| 10. Final calibration of the MUMP 9 omegatron. | 18 |
| 11. Final calibration of the MUMP 10 omegatron. | 19 |
| 12. Electron temperature and density probe. | 21 |
| 13. ETDP system timing and output format. | 22 |
| 14. MUMP 9 minimum angle of attack vs. altitude. | 24 |
| 15. MUMP 10 minimum angle of attack vs. altitude. | 25 |

LIST OF ILLUSTRATIONS (Concluded)

| Figure | Page |
|--|------|
| 16. MUMP 9 sequence of events. | 30 |
| 17. MUMP 10 sequence of events. | 31 |
| 18. MUMP 9 omegatron current vs. flight time. | 33 |
| 19. MUMP 10 omegatron current vs. flight time. | 34 |
| 20. $K(S_0, \alpha)$ vs. altitude for MUMP 9. | 36 |
| 21. $K(S_0, \alpha)$ vs. altitude for MUMP 10. | 37 |
| 22. MUMP 9 ambient N_2 density vs. altitude. | 38 |
| 23. MUMP 10 ambient N_2 density vs. altitude. | 39 |
| 24. MUMP 9 neutral particle temperature vs. altitude. | 43 |
| 25. MUMP 10 neutral particle temperature vs. altitude. | 44 |
| 26. Charged particle results for MUMP 10. | 45 |
| 27. Solar flux at 10.7 cm wavelength. | 47 |
| 28. Three-hour geomagnetic activity index (a_p). | 48 |

1. INTRODUCTION

The results of the launching of two Marshall-University of Michigan Probes (MUMP 9 and MUMP 10), Nike-Tomahawk sounding rocket payloads, are summarized in this report. The MUMP is similar to the Thermosphere Probe (TP), described by Spencer, Brace, Carignan, Tausch, and Niemann (1965), which was developed jointly by the Space Physics Research Laboratory (SPRL) of The University of Michigan and the Goddard Space Flight Center, Laboratory for Planetary Atmospheres. The MUMPs were developed by SPRL for the Marshall Space Flight Center, Aero-Astroynamics Laboratory. The TP is an ejectable instrument package designed for the purpose of studying the variability of the earth's atmospheric parameters in the altitude region between 120 and 350 km. Background information for both the neutral particle and charged particle portions of the experiments, along with a full bibliography, is given by Tausch, Carignan, Nagy, and Niemann (1968).

The MUMP 9 payload included an omegatron mass analyzer, a molecular fluorescence densitometer, a "mini-tilty" filter, and a lunar position sensor. This complement of instruments permitted the determination of the molecular nitrogen density and temperature in the altitude range from approximately 143 to 297 km over Wallops Island, Virginia, during January 1971.

The MUMP 10 payload included an omegatron mass analyzer, an electron temperature probe (Spencer, Brace, and Carignan, 1962), a cryogenic densitometer, and a solar position sensor. This complement of instruments permitted the determination of the molecular nitrogen density and temperature and the charged particle density and temperature in the altitude range from approximately 145 to 290 km over Wallops Island, Virginia, during the afternoon preceding the MUMP 9 launch in January 1971.

A general description of the payload kinematics, orientation analysis, and the technique for the reduction and analysis of the data is given by Tausch, Carignan, Niemann, and Nagy (1965) and Carter (1968). The results of the cryogenic and fluorescence density and temperature measurements are the subjects of individual reports and are not covered in this document.

2. GENERAL FLIGHT INFORMATION

The general flight information for MUMP 9 and MUMP 10 is listed below. Table I gives the flight times and altitudes of significant events which occurred during the flights. Some of these were estimated and are so marked. The others were obtained from the telemetry records and radar trajectory information.

| | | |
|--------------|----------------------|----------------------|
| Flight: | MUMP 9 | MUMP 10 |
| Launch Date: | 16 January 1971 | 15 January 1971 |
| Launch Time: | 00:55:00.117 GMT | 20:30:00.127 GMT |
| Location: | Wallops Island, Va. | Wallops Island, Va. |
| | Lat: 37°50'14.915"N | Lat: 37°50'14.915"N |
| | Long: 75°29'01.693"W | Long: 75°29'01.693"W |

Apogee Parameters:

| | | |
|----------------------|-------------|-------------|
| Altitude: | 297.1 km | 289.6 km |
| Horizontal Velocity: | 336.7 m/sec | 380.1 m/sec |
| Flight Time: | 269.0 sec | 265.5 sec |

TP Motion:

| | | |
|----------------|-------------|------------|
| Tumble Period: | 3.116 sec | 2.120 sec |
| Roll Rate: | ~12 deg/sec | 21 deg/sec |

TABLE I

TABLE OF EVENTS

| Event | MUMP 9 | | MUMP 10 | |
|-----------------------|----------------------|------------------|----------------------|------------------|
| | Flight Time (sec) | Altitude (km) | Flight Time (sec) | Altitude (km) |
| Lift-off | 0 | 0 | 0 | 0 |
| 1st Stage Burnout | 3.7 | 1.6 (est.) | 3.6 | 1.6 (est.) |
| 2nd State Ignition | 11.6 | 6.4 | 11.8 | 6.5 |
| 2nd Stage Burnout | 21.2 | 19.7 | 21.3 | 19.7 |
| Despin | 43.4 (est.) | 67.9 (est.) | 43.7 (est.) | 67.6 (est.) |
| TP Ejection | 45.4 | 72.0 | 45.7 | 71.6 |
| Omegatron Breakoff | 75.5 | 128.9 | 79.9 | 134.6 |
| Omegatron Filament On | 76.7 | 131.0 | 81.4 | 137.1 |
| Peak Altitude | 269.0 | 297.1 | 265.5 | 289.6 |
| L.O.S. | 503.0 | — | 501.0 | — |

3. LAUNCH VEHICLE

The launch vehicles for MUMP 9 and MUMP 10 were two-stage, solid propellant Nike-Tomahawk combinations. The first stage of each vehicle, a Hercules M5E1 Nike motor, had an average thrust of 49,000 lb and burned for approximately 3.6 sec. The Nike booster, plus adapter, was 145.2 in. long and 16.5 in. in diameter. Its weight unburned was approximately 1325 lb. The sustainer stage, Thiokol's TE416 Tomahawk motor, provided an average thrust of 11,000 lb and burned for about 9 sec. The Tomahawk, 141.4 in. long and 9 in. in diameter, weighed 530 lb unburned. The MUMP 9 payload, which was 93.1 in. long and weighed 163 lb including despin and adapter modules, made the total vehicle 379.4 in long with a gross lift-off weight of 2018 lb. The MUMP 10 payload, which was 89.2 in long and weighed 169 lb including despin and adapter modules, made the total vehicle 375.5 in long with a gross lift-off weight of 2024 lb. The vehicles are illustrated in Figures 1, 2, and 3.

Both launch vehicles performed flawlessly. MUMP 9 reached a summit altitude of 297.1 km at 269.0 sec of flight time, and MUMP 10 reached a summit altitude of 289.6 km at 265.5 sec of flight time.

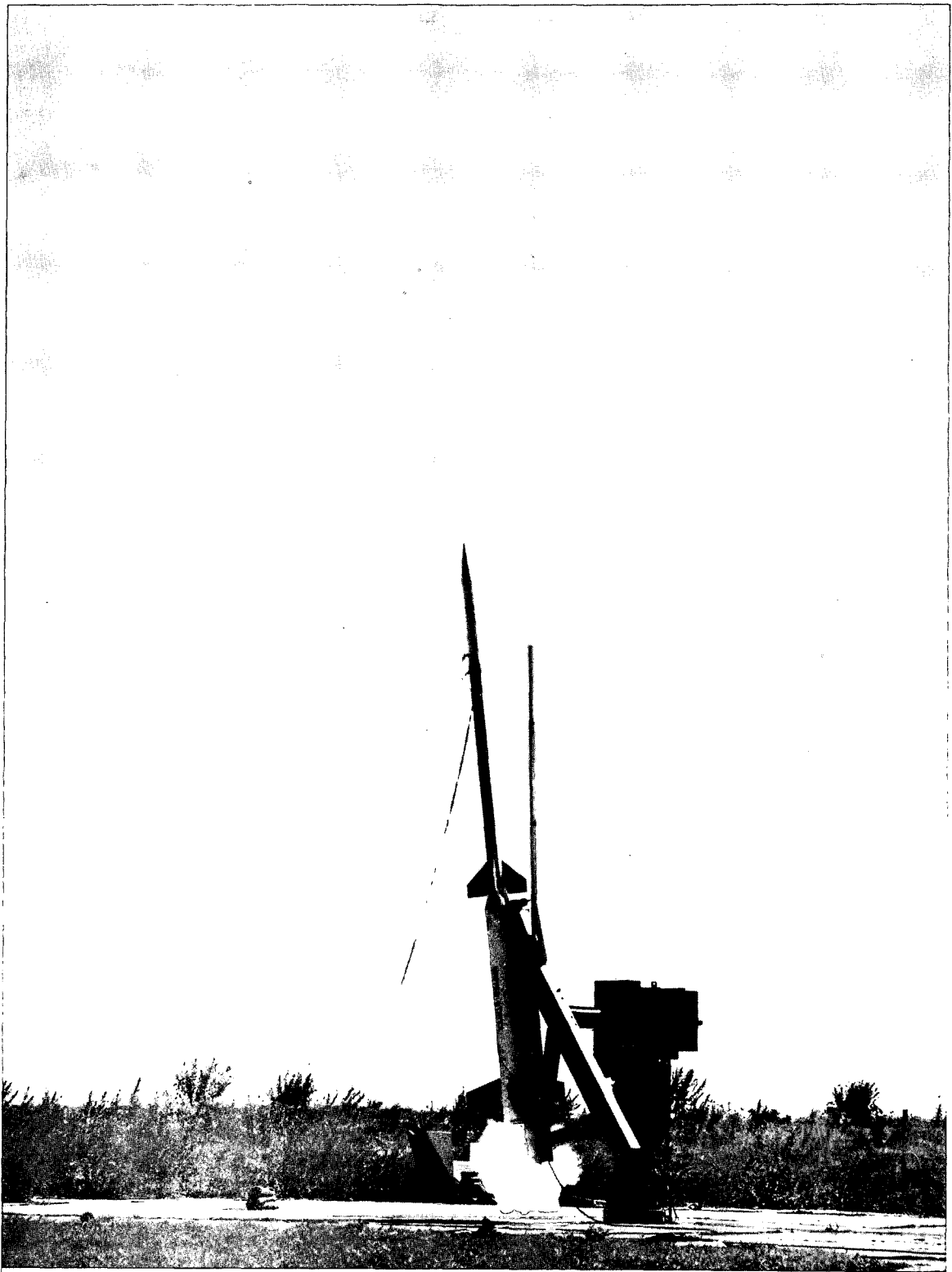

Figure 1. Nike-Tomahawk with thermosphere probe payload.

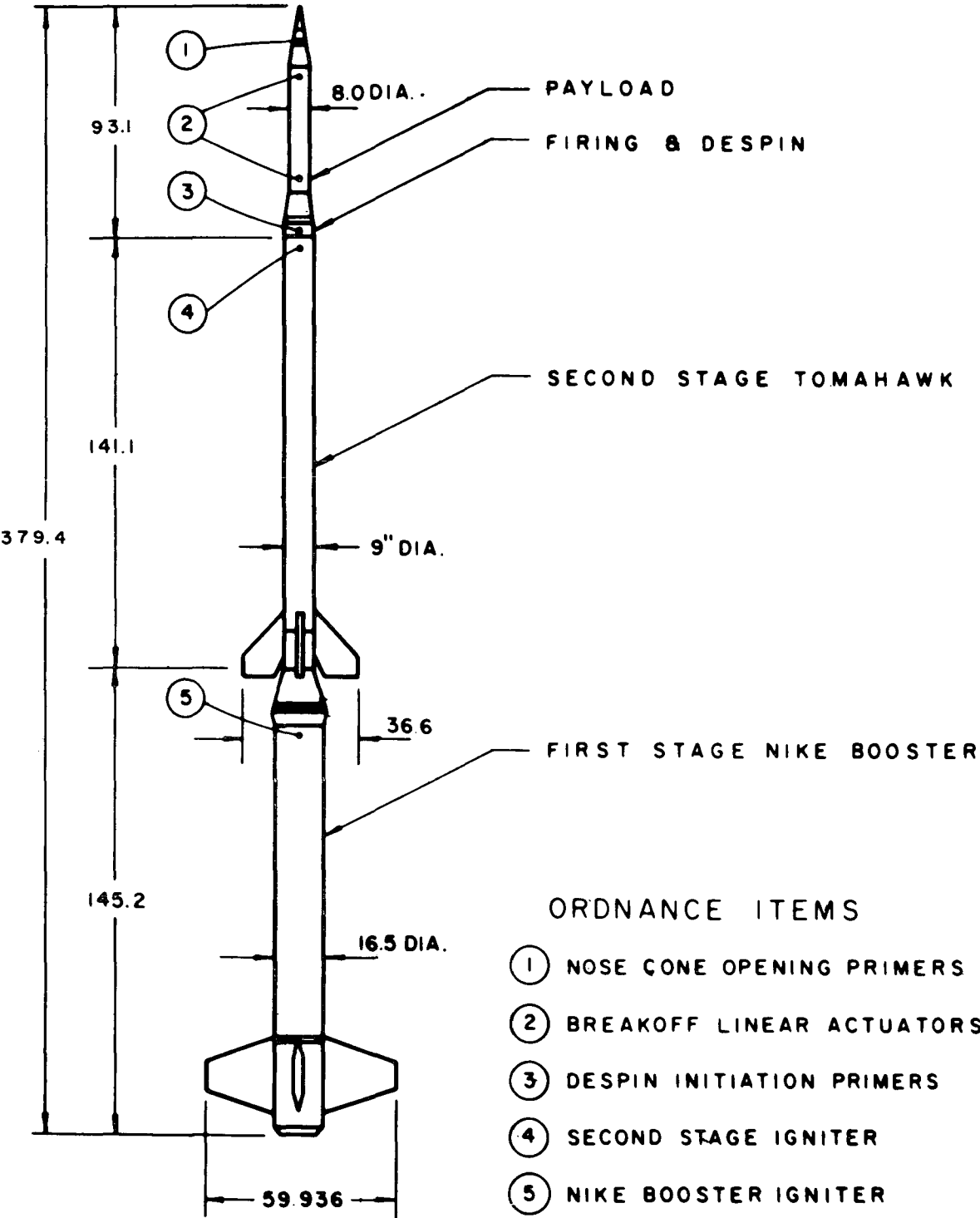

Figure 2. Nike-Tomahawk dimensions, MUMP 9.

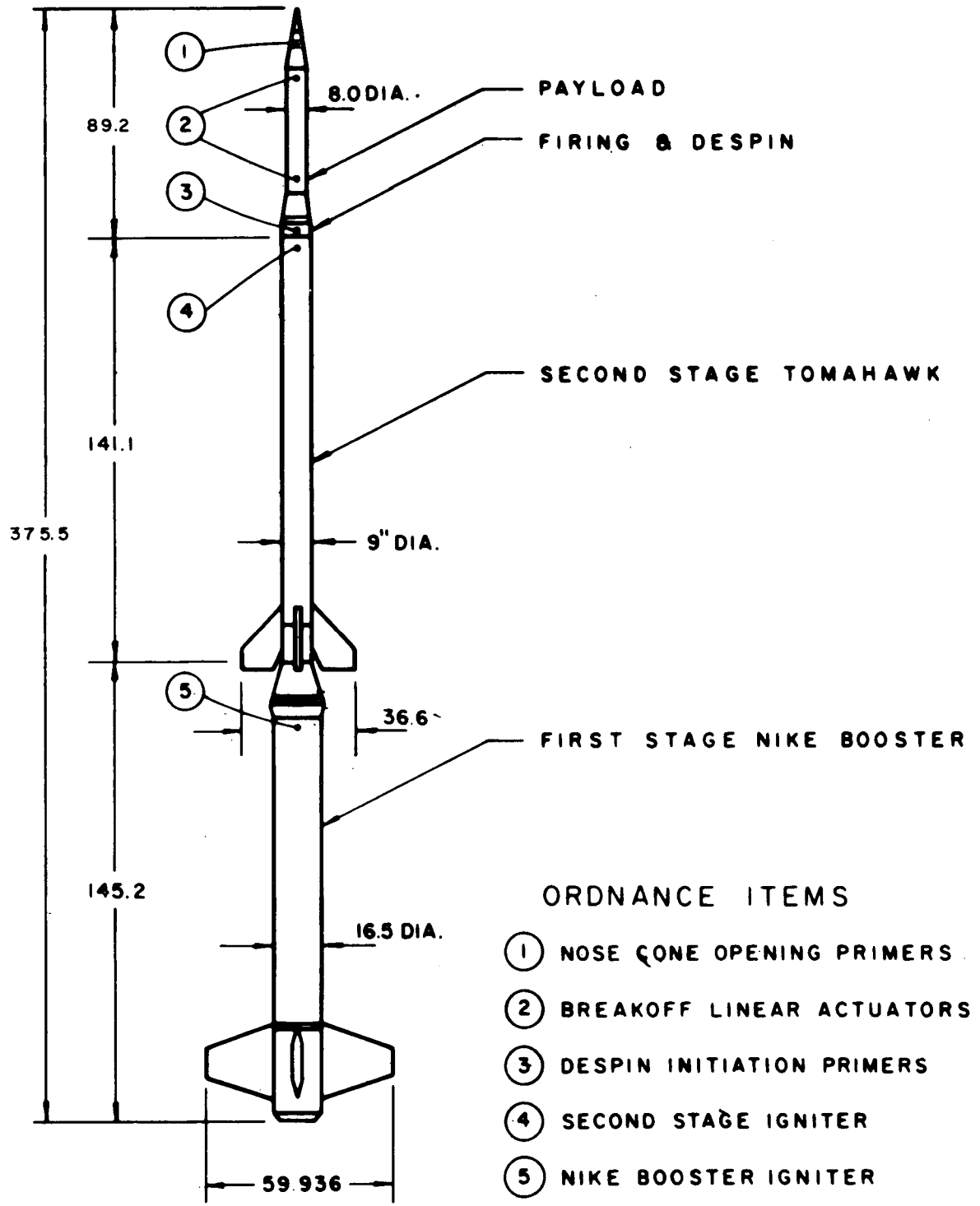

Figure 3. Nike-Tomahawk dimensions, MUMP 10.

4. NOSE CONE

Figure 4 is a diagram of the payload of MUMP 9 including the nose cone, the despin mechanism, and the adapter section. Figure 5 is the same for MUMP 10. An assembly drawing of the 8-in. nose cone is given in Figure 6.

The MUMP 9 payload was despun at 68 km (43 sec after launch), and the ejection began at 72 km (45 sec after launch), resulting in a tumble period of 3.116 sec. The omegatron breakoff device was removed at 129 km (76 sec after launch), and the omegatron filament was turned on approximately 2 sec later.

The MUMP 10 payload was despun at 68 km (44 sec after launch), and the ejection began at 72 km (46 sec after launch), resulting in a tumble period of 2.120 sec. The omegatron breakoff device was removed at 135 km (80 sec after launch), and the omegatron filament was turned on approximately 2 sec later.

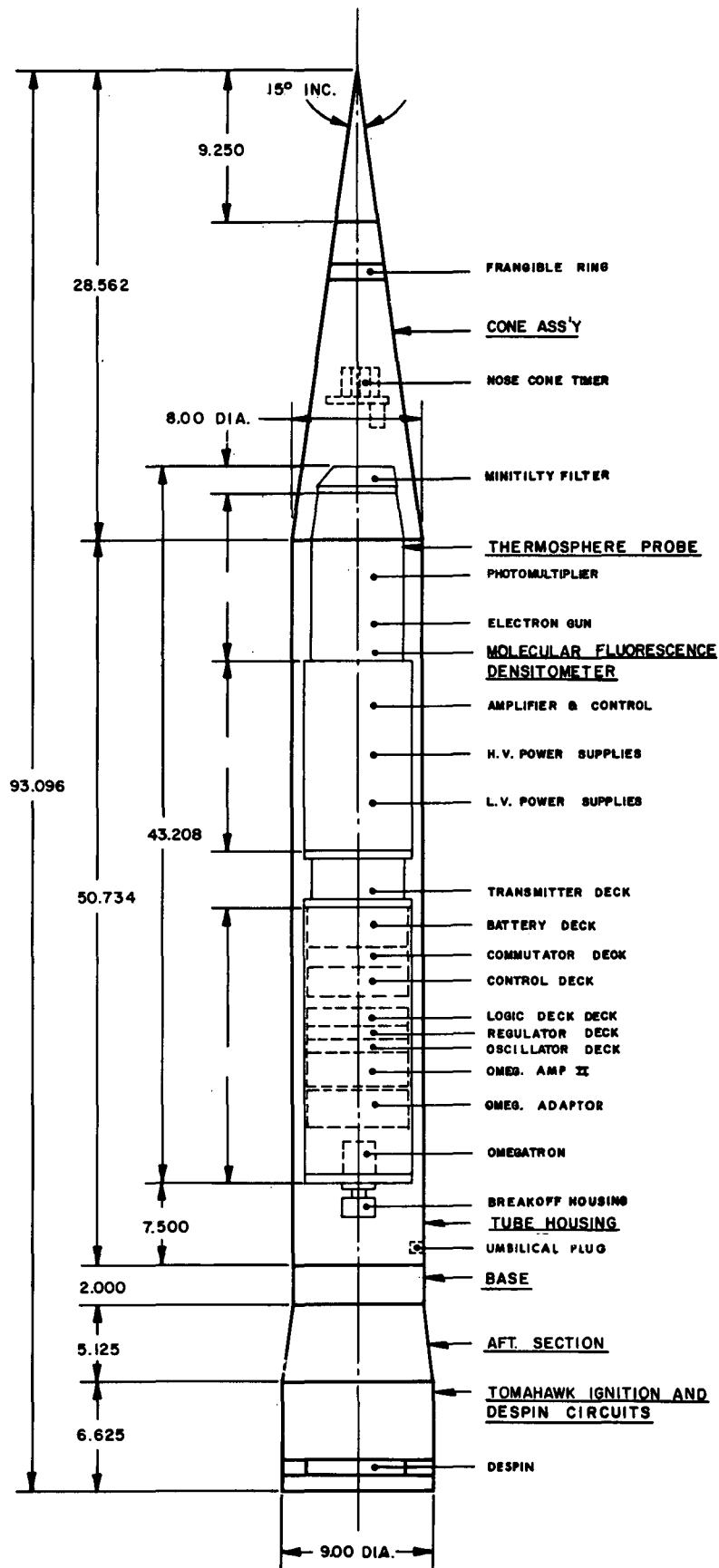

Figure 4. MUMP 9 instrumentation design.

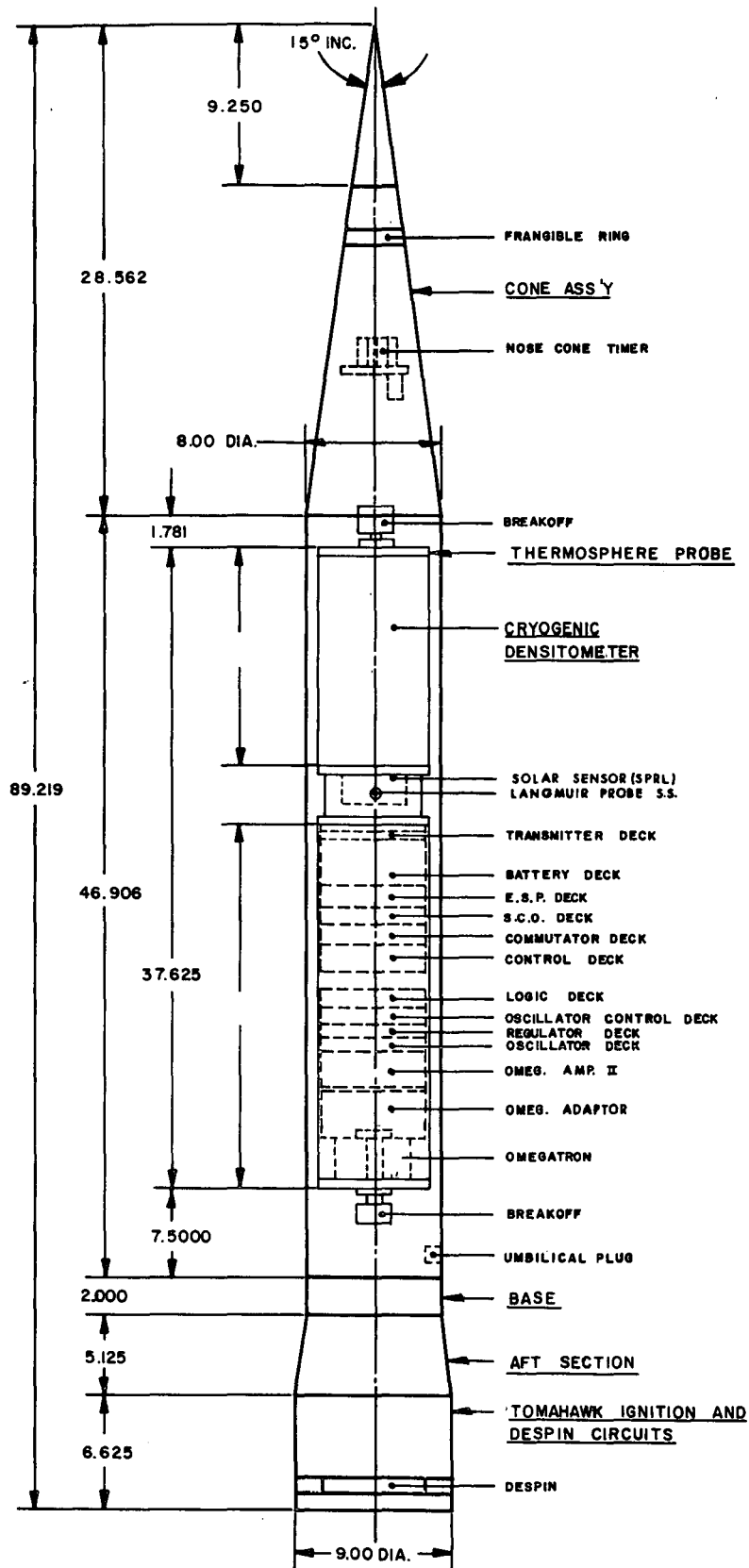

Figure 5. MUMP 10 instrumentation design.

FOLDOUT FRAME 1

FOLDOUT FRAME 2

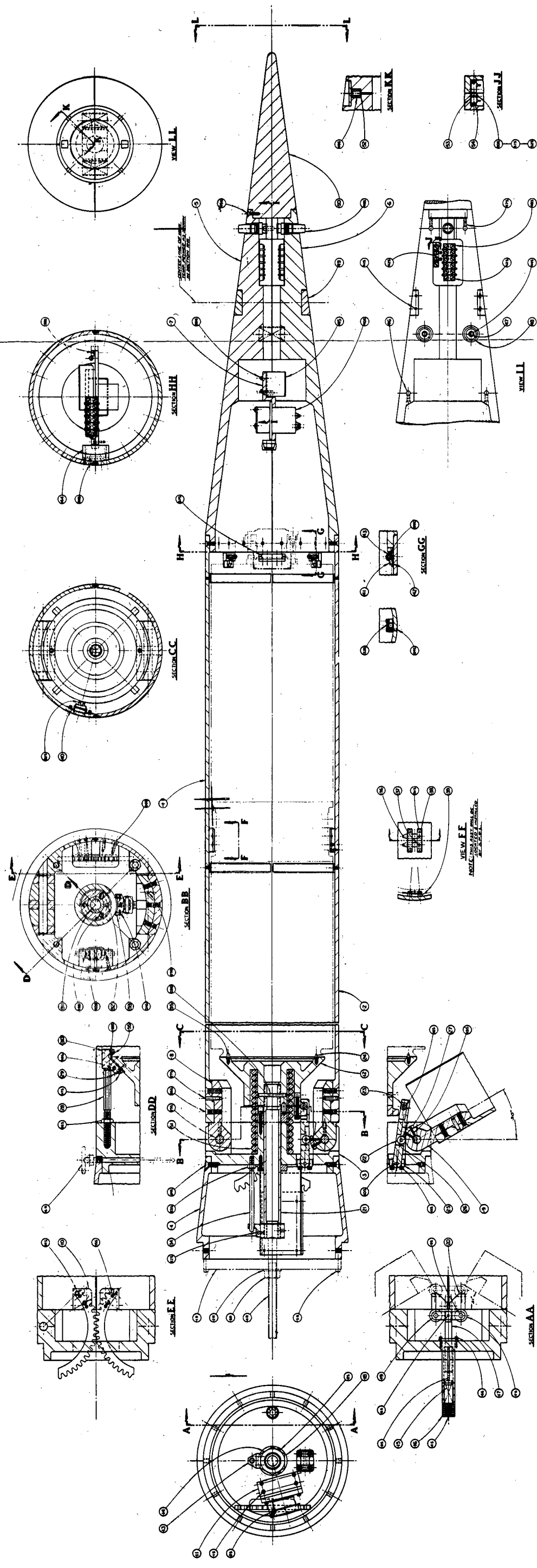

Figure 6. Assembly drawing, 8-in. nose cone.

5. THERMOSPHERE PROBE

The TP used for the MUMP 9 payload was a cylinder 43.2 in. long and 7.25 in. in diameter, and weighed 68 lb. The major instrumentation of the payload included an omegatron mass analyzer, a molecular fluorescence densitometer and a mini-tilty filter. Supporting instrumentation included a lunar position sensor for use in determining the attitude of the TP. The diagram in Figure 4 shows the location of instrumentation and supporting electronics in the nose cone and Figure 7 is the system block diagram for MUMP 9.

The TP used for the MUMP 10 payload was a cylinder 37.6 in. long and 7.25 in. in diameter, and weighed 75 lb. The major instrumentation of this payload included an omegatron mass analyzer, an electron temperature probe, and a cryogenic densitometer. Supporting instrumentation included a solar position sensor for use in determining the attitude of the TP. The diagram in Figure 5 shows the location of instrumentation and supporting electronics in the nose cone and Figure 8 is the system block diagram for MUMP 10.

5.1. OMEGATRON

Table II lists the sensitivity of the omegatrons and the characteristics of the linear electrometer amplifier current detector used to monitor the omegatron output currents. The omegatron envelope and breakoff configuration are shown in Figure 9. The calibrations of the MUMP 9 and MUMP 10 omegatrons, performed at SPRL during October and November of 1970, are shown in Figures 10 and 11.

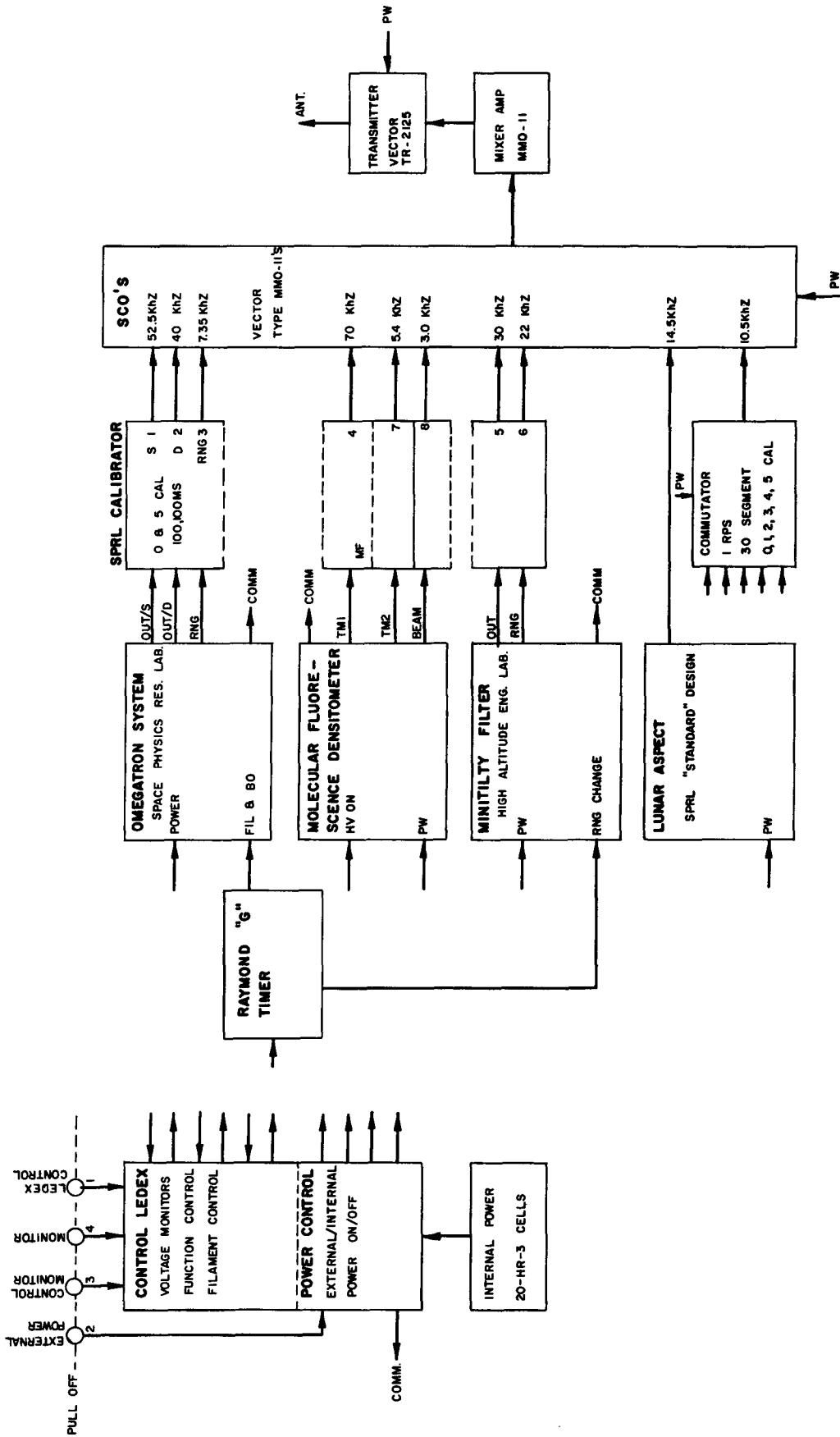

Figure 7. MUMP 9 system block diagram.

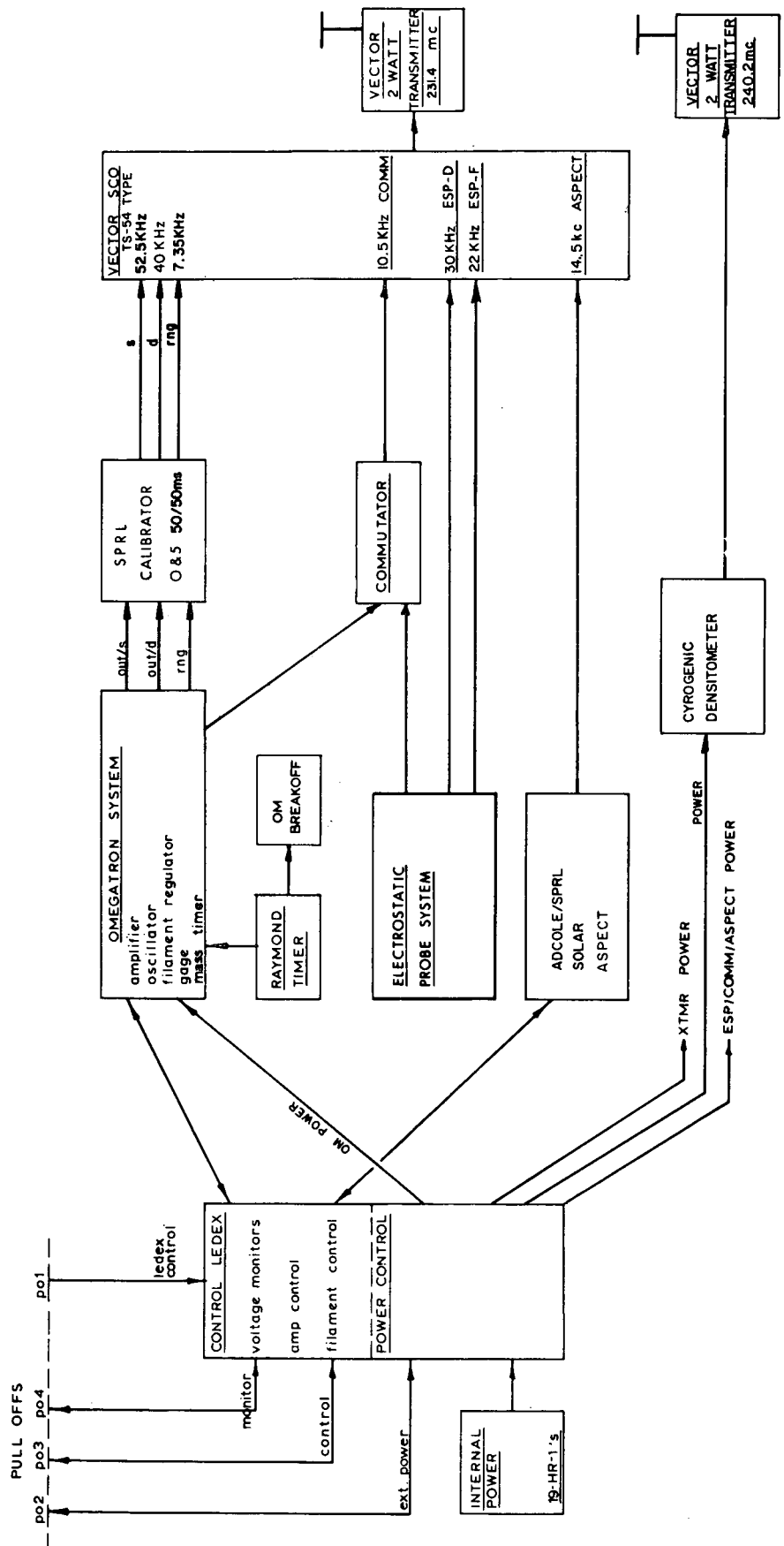

Figure 8. MUMP 10 system block diagram.

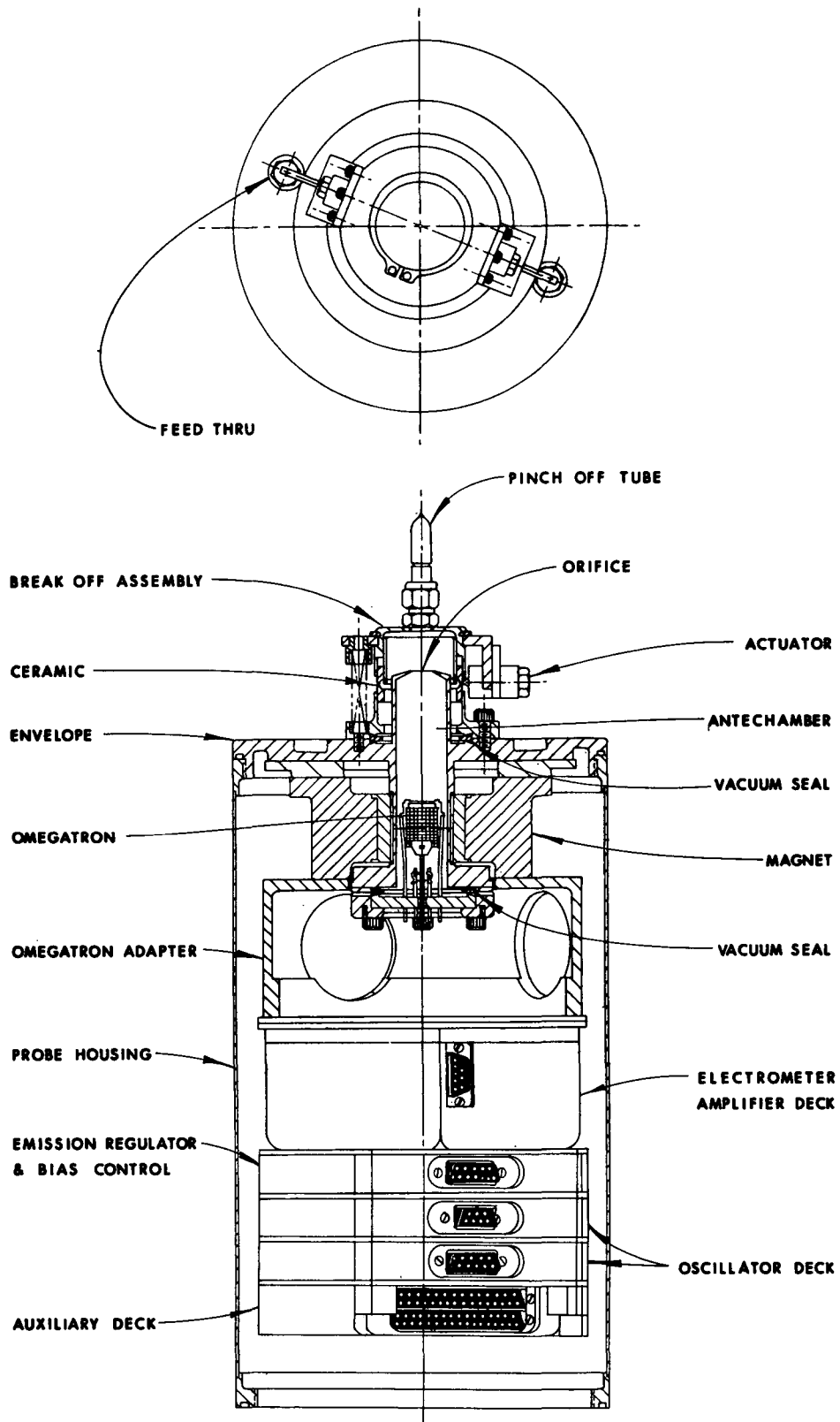

Figure 9. Omegatron and breakoff configuration.

TABLE II
 OMEGATRON DATA
 (MUMP 9)

Calibration

Normalized N₂ Sensitivity: 1.46×10^{-5} A/torr

Electrometer Amplifier

OUT/S

| <u>Range</u> | <u>Indicator</u> | <u>Resistor</u> | <u>Gain</u> | <u>Bias</u> |
|--------------|------------------|------------------------|-------------|-------------|
| 1-1 | 0.60 V | 1.000×10^{12} | -1.01 | + 3.02 V |
| 1-2 | 0.90 V | 1.000×10^{12} | -1.01 | - 1.01 V |
| 1-3 | 1.21 V | 1.000×10^{12} | -1.01 | - 5.03 V |
| 1-4 | 1.51 V | 1.000×10^{12} | -1.00 | - 9.05 V |
| 1-5 | 1.81 V | 1.000×10^{12} | -1.00 | -13.07 V |
| 1-6 | 2.11 V | 1.000×10^{12} | -1.00 | -17.08 V |
| 1-7 | 2.41 V | 1.000×10^{12} | -1.01 | -21.22 V |
| 2-1 | 3.00 V | 6.664×10^{10} | -1.01 | + 3.02 V |
| 2-2 | 3.30 V | 6.664×10^{10} | -1.01 | - 1.01 V |
| 2-3 | 3.61 V | 6.664×10^{10} | -1.01 | - 5.03 V |
| 2-4 | 3.91 V | 6.664×10^{10} | -1.00 | - 9.05 V |
| 2-5 | 4.21 V | 6.664×10^{10} | -1.00 | -13.07 V |
| 2-6 | 4.51 V | 6.664×10^{10} | -1.00 | -17.08 V |
| 2-7 | 4.81 V | 6.664×10^{10} | -1.01 | -21.22 V |

OUT/D

| <u>Range</u> | <u>Indicator</u> | <u>Resistor</u> | <u>Gain</u> | <u>Bias</u> |
|--------------|------------------|------------------------|-------------|-------------|
| 1 | — | 1.000×10^{12} | -0.2514 | 0.0089 V |
| 2 | — | 6.664×10^{10} | -0.2514 | 0.0089 V |

Table II (Concluded)

(MUMP 10)

CalibrationNormalized N₂ Sensitivity: 1.33×10^{-5} A/torrElectrometer Amplifier

OUT/S

| <u>Range</u> | <u>Indicator</u> | <u>Resistor</u> | <u>Gain</u> | <u>Bias</u> |
|--------------|------------------|------------------------|-------------|-------------|
| 1-1 | 0.50 V | 1.000×10^{12} | -1.00 | + 2.99 V |
| 1-2 | 0.80 V | 1.000×10^{12} | -1.00 | - 1.02 V |
| 1-3 | 1.10 V | 1.000×10^{12} | -1.00 | - 4.99 V |
| 1-4 | 1.40 V | 1.000×10^{12} | -1.00 | - 8.97 V |
| 1-5 | 1.70 V | 1.000×10^{12} | -1.00 | -12.97 V |
| 1-6 | 2.00 V | 1.000×10^{12} | -1.00 | -17.00 V |
| 1-7 | 2.30 V | 1.000×10^{12} | -1.00 | -21.02 V |
| 2-1 | 2.90 V | 6.664×10^{10} | -1.00 | + 2.99 V |
| 2-2 | 3.20 V | 6.664×10^{10} | -1.00 | - 1.02 V |
| 2-3 | 3.49 V | 6.664×10^{10} | -1.00 | - 4.99 V |
| 2-4 | 3.79 V | 6.664×10^{10} | -1.00 | - 8.97 V |
| 2-5 | 4.09 V | 6.664×10^{10} | -1.00 | -12.97 V |
| 2-6 | 4.39 V | 6.664×10^{10} | -1.00 | -17.00 V |
| 2-7 | 4.68 V | 6.664×10^{10} | -1.00 | -21.02 V |

OUT/D

| <u>Range</u> | <u>Indicator</u> | <u>Resistor</u> | <u>Gain</u> | <u>Bias</u> |
|--------------|------------------|------------------------|-------------|-------------|
| 1 | — | 1.000×10^{12} | -0.2503 | 0.0039 V |
| 2 | — | 6.664×10^{10} | -0.2503 | 0.0039 V |

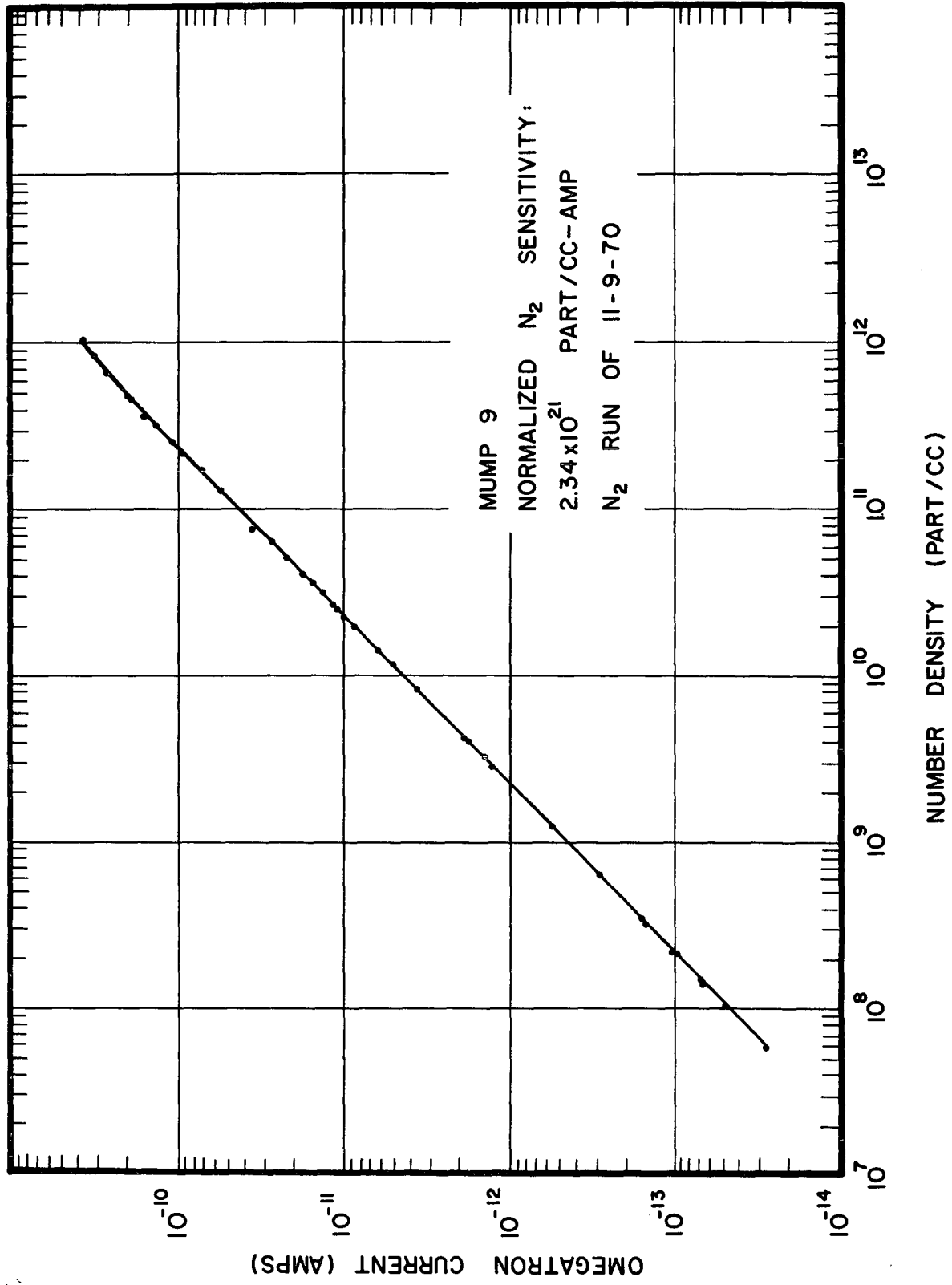

Figure 10. Final calibration of the MUMP 9 omegatron.

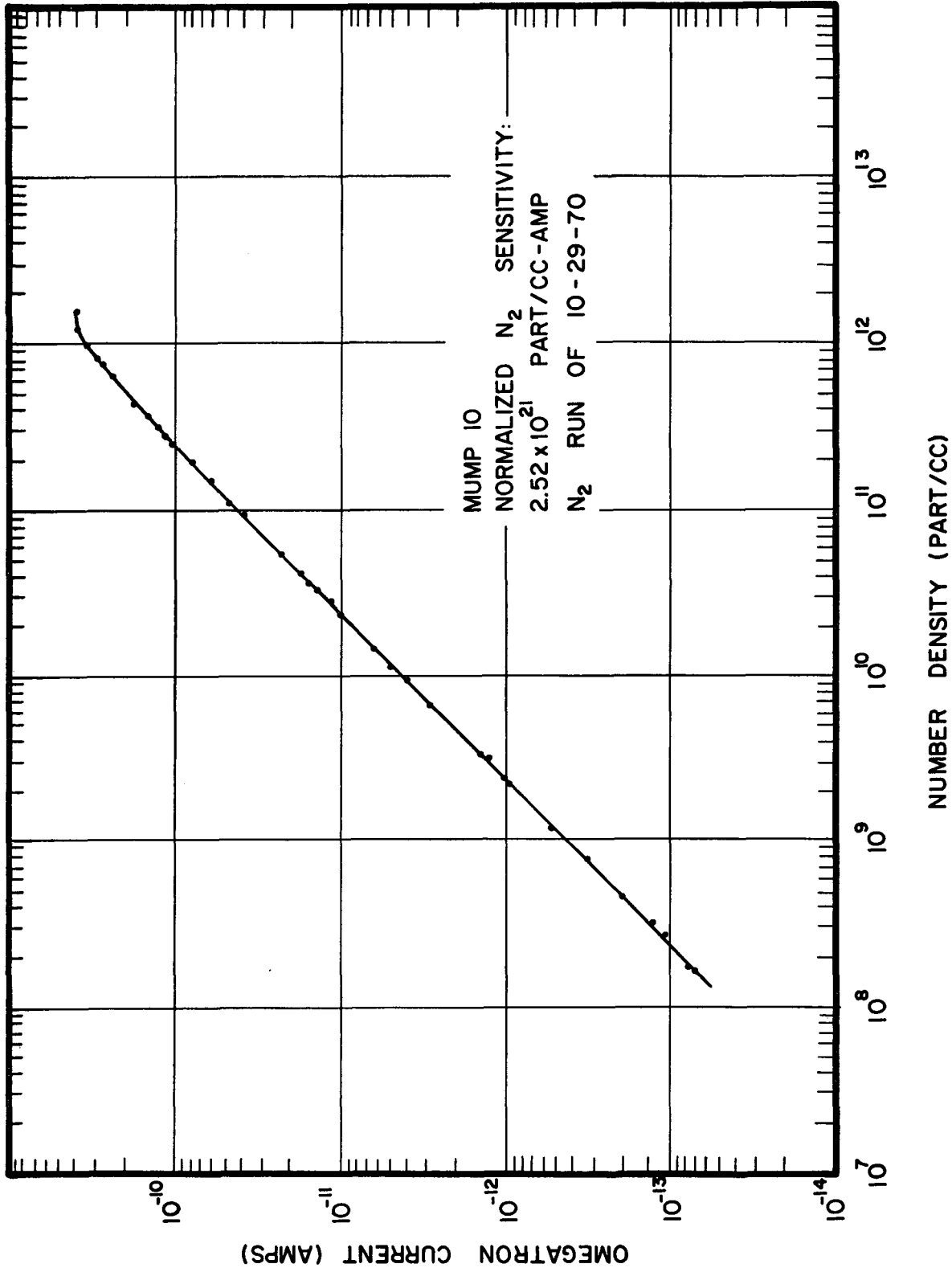

Figure 11. Final calibration of the MUMP 10 omegatron.

5.2. ELECTRON TEMPERATURE AND DENSITY PROBE

The electron temperature and density probe consists of two cylindrical Langmuir probes placed in the plasma, and an electronics unit which measures the current collected by the probes as they are swept through a series of ramp voltages. A typical Langmuir probe is shown in Figure 12. For MUMP 10 probe 1 is stainless steel and probe 2 is rhodium-plated stainless steel. MUMP 9 did not carry the instrument.

The electronics unit consisted of a dc-dc converter, a ΔV ramp generator, a three-range current detector, and associated logic and control circuits. Timing and sequencing of the various functions are shown in Figure 13. The pertinent system parameters follow.

| | |
|---|------------------------------|
| (a) Input Power | 2.24 W at 28 V |
| (b) Sensitivity | |
| Range 1 | 20 μ A full scale (5 V) |
| Range 2 | 2.0 μ A full scale (5 V) |
| Range 3 | 0.2 μ A full scale (5 V) |
| (c) Ramp Voltage (ΔV) | |
| High ΔV | 80.0 V/sec -3 V to +5 V |
| Low ΔV | 26.7 V/sec -1 V to 1.67 V |
| Period | 100.0 msec |
| (d) Output | |
| Voltage | -0.50 V to +5.80 V |
| Resistance | 2000 Ω |
| Bias Level | 0.50 V |
| (e) System Calibration | |
| Calibration occurs every 36 sec for a duration of 600 msec. | |

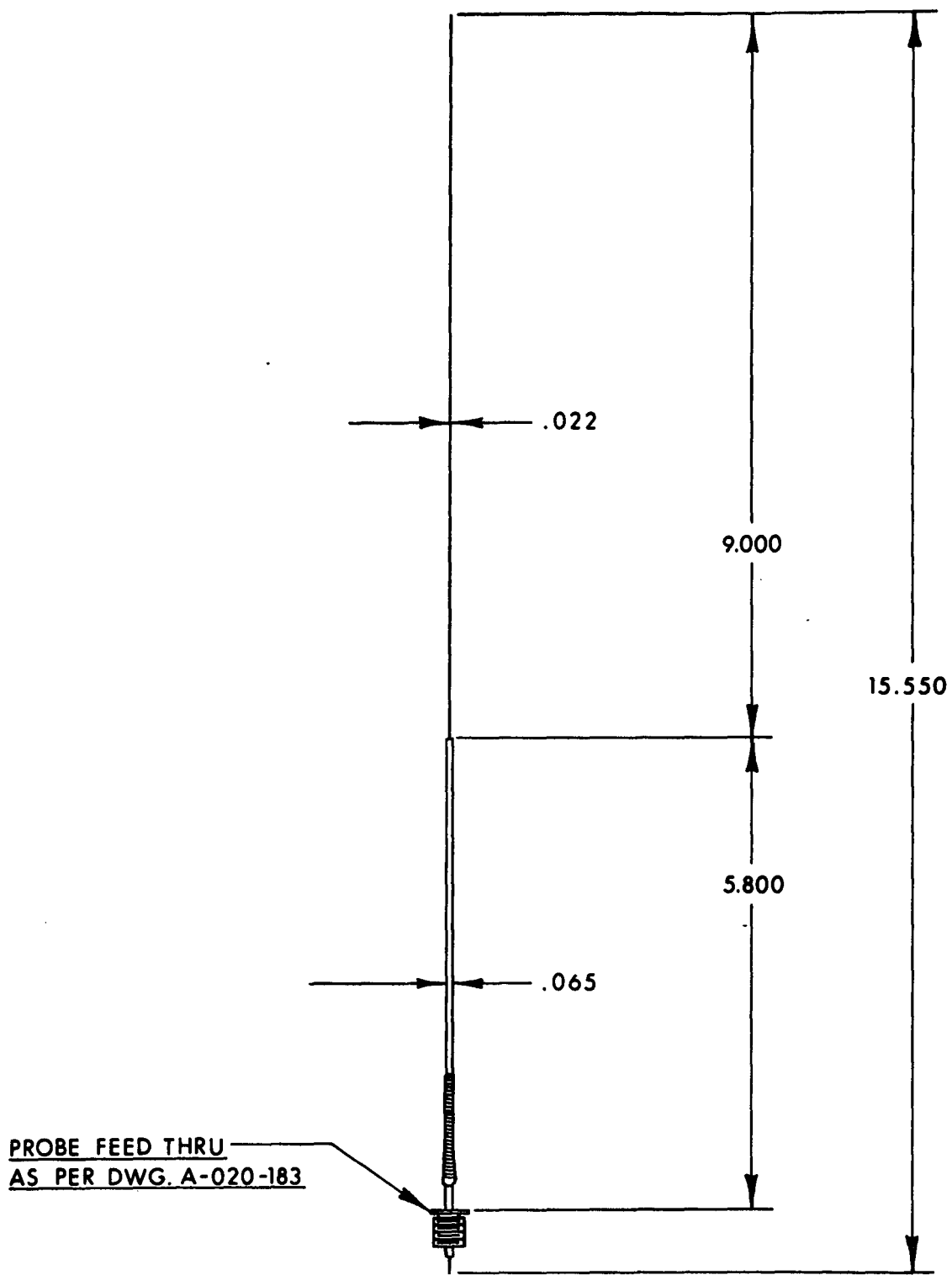
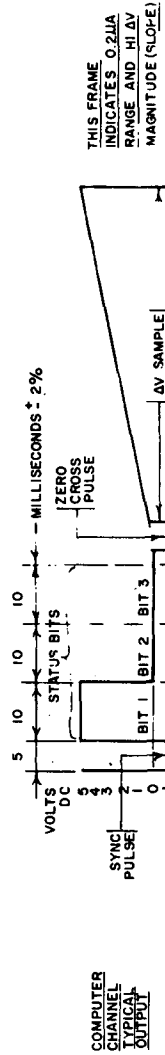
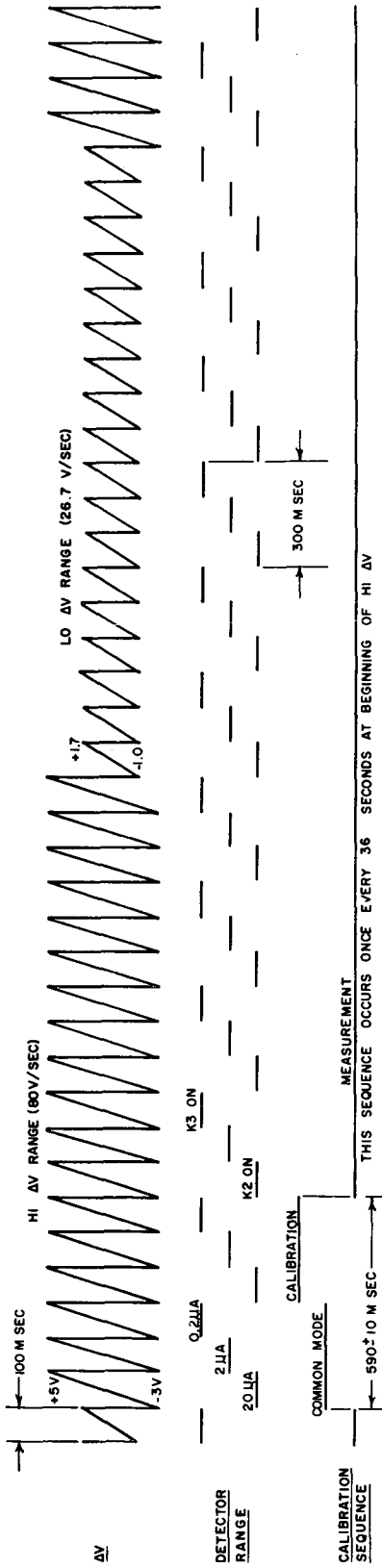

Figure 12. Electron temperature and density probe.



STAT:JS BIT CODING

| BIT 1 | BIT 2 | DETECTOR | RELAYS ON | BIT 3 | ΔV SLOPE | ΔV MAGNITUDE | |
|-------|-------|---------------------------------|-----------|-------|------------|--------------|--------------------------------|
| 0 | 5V | 20 μA | K2 | 0 | 80 V/SEC | -3 TO +5 | |
| 5V | 5V | 2 μA | NONE | 5V | 26.7 V/SEC | -1 TO +1.7 | |
| 5V | 0 | 0.2 μA | K3 | | | | |
| 0 | 0 | CALIBRATION MODE FOR ALL RANGES | | | | | K2 OR K3 ON ACCORDING TO RANGE |



Figure 13. EIDP system timing and output format.

5.3. SUPPORT MEASUREMENTS AND INSTRUMENTATION

5.3.1. Aspect Determination System

The MUMP 9 payload utilized a lunar sensor designed and built by SPRL which was identical to those used on previous nighttime flights. MUMP 10 included a solar aspect sensor built by Adcole Corporation similar to those used on previous daytime flights. A single-eye system (120 deg field of view) was used rather than the triple-eye (360 deg field of view) of previous flights, and the accompanying electronics were modified accordingly.

The attitude of each TP was determined by using the method of referencing the solar (lunar) vector and the velocity vector (Carter, 1968). The resulting minimum angle of attack, determined to an estimated accuracy of ± 5 deg, is plotted versus altitude in Figures 14 and 15.

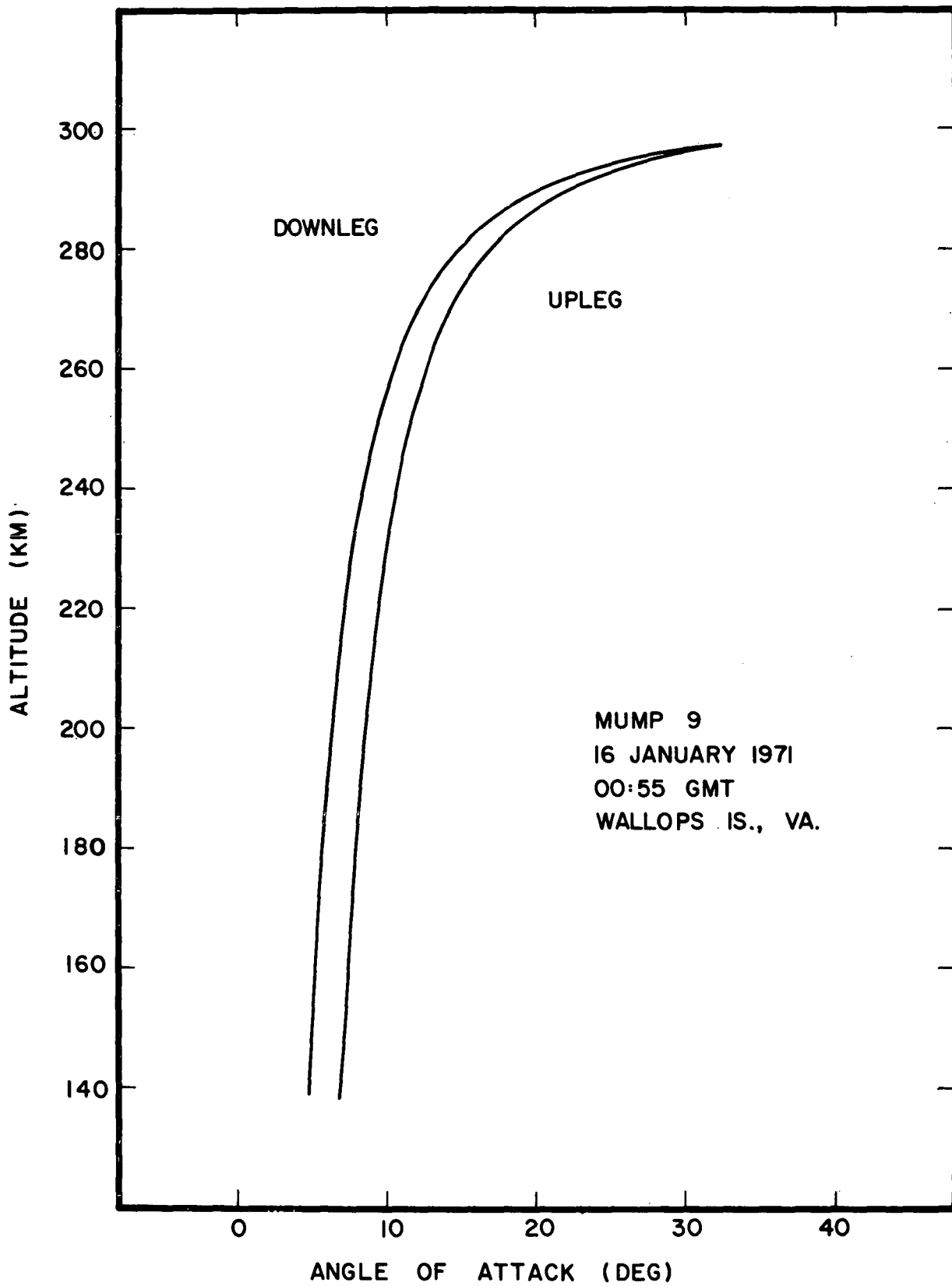

Figure 14. MUMP 9 minimum angle of attack vs. altitude.

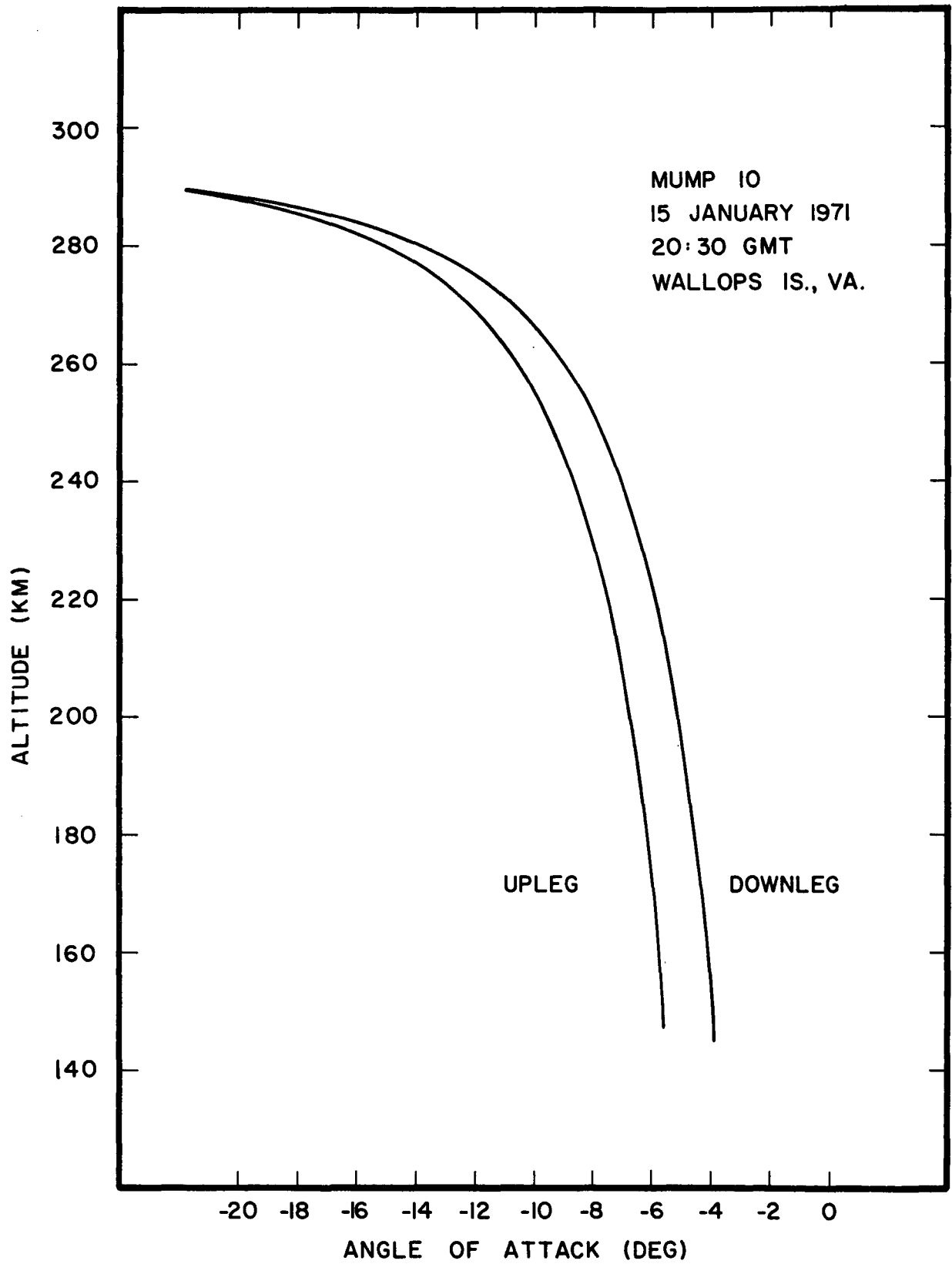

Figure 15. MUMP 10 minimum angle of attack vs. altitude.

5.3.2. Telemetry

The MUMP 9 payload data were transmitted in real time by a ten-channel PAM/FM/FM telemetry system at 240.2 MHz with a nominal output of 2.5 W. The MUMP 10 data were transmitted in real time by a seven-channel PAM/FM/FM telemetry system at 244.3 MHz, also with a nominal output of 2.5 W. The subcarrier channels are outlined below.

| | <u>MUMP 9</u> | <u>MUMP 10</u> |
|----------------------|------------------------------|------------------------------------|
| Transmitter: | TR-2125 (Serial No. 981) | TRPT-251-RA01 (Serial No. 2499) |
| Power Amplifier: | ————— | TRFP-2V (Serial No. 458) |
| Mixer Amplifier: | MMA-12 (Serial No. 11847) | TA-58A (Serial No. 1162) |
| Subcarrier Channels: | MMO-11 | TS-54 |

MUMP 9

| IRIG Band | Serial No. | Center Frequency | Function | Low Pass Filter Used |
|-----------|------------|------------------|------------|----------------------|
| 18 | 16762 | 70 kHz | MFD TML | 790 CD |
| 17 | 16594 | 52.5 kHz | OM OUT/S | 110 CD |
| 16 | 19165 | 40 kHz | OM OUT/D | 110 CD |
| 15 | 16371 | 30 kHz | MTF | 450 CD |
| 14 | 16300 | 22 kHz | MTF Range | 330 CD |
| 13 | 15285 | 14.5 kHz | Aspect | 330 CD |
| 12 | 18736 | 10.5 kHz | Commutator | 160 CD |
| 11 | 15945 | 7.35 kHz | OM Range | 110 CD |
| 10 | 15844 | 5.4 kHz | MFD TM2 | 81 CD |
| 8 | 24375 | 3 kHz | MFD Beam | 45 CD |

MUMP 10

| IRIG Band | Serial No. | Center Frequency | Function | Low Pass Filter Used |
|-----------|------------|------------------|------------|----------------------|
| 17 | 1738-5 | 52.5 kHz | OM OUT/S | 110 CD |
| 16 | 1063-25 | 40 kHz | OM OUT/D | 110 CD |
| 15 | 1890-25 | 30 kHz | ESP-D | 450 CD |
| 14 | 3221-25 | 22 kHz | ESP-F | 330 CD |
| 13 | 3460-25 | 14.5 kHz | Aspect | 330 CD |
| 12 | 1685-5 | 10.5 kHz | Commutator | 160 CD |
| 11 | 1567 | 7.35 kHz | OM Range | 110 CD |

Instrumentation power requirements for MUMP 9 totaled approximately 83 W, supplied by a Yardney HR-3 Silvercell battery pack of a nominal 29 V output. For MUMP 10 the total power requirement was approximately 67 W, supplied by a Yardney HR-1 Silvercell battery pack of a nominal 28 V output.

5.3.3 Housekeeping Monitors

Outputs from various monitors throughout the instrumentation provided information bearing on the operations of the electronic components during the flights. These outputs were fed to thirty segment commutators which ran at one rps. The commutator assignments were as follows:

COMMUTATOR FORMAT FOR MUMP 9

| Segment No. | Segment Assignment |
|-------------|--|
| 1 | 1 V Calibration |
| 2 | OUT/D |
| 3 | Omegatron Range |
| 4 | Open |
| 5 | MFD Telemetry 1 (more sensitive) |
| 6 | MFD Telemetry 2 (less sensitive) |
| 7 | MFD Emission Current Monitor |
| 8 | MFD High Voltage Monitor |
| 9 | MT +15 Voltage Monitor |
| 10 | MT -15 Voltage Monitor |
| 11 | MT + 5 Voltage Monitor |
| 12 | MT High Voltage Photomultiplier |
| 13 | MT High Voltage Monitor |
| 14 | Thermistor - Transmitter Temperature |
| 15 | Thermistor - High Voltage Temperature |
| 16 | Thermistor - Photomultiplier Temperature |
| 17 | Open |
| 18 | Internal Pressure Monitor |
| 19 | Thermistor - Gauge Temperature |
| 20 | Thermistor - Amplifier Temperature |
| 21 | Open |
| 22 | Open |
| 23 | Bias Voltage Monitor |
| 24 | Filament Monitor |
| 25 | RF Voltage Monitor |
| 26 | Emission Current Monitor |
| 27 | Battery Voltage Monitor |
| 28 | 0 V Calibration |
| 29 | 5 V Calibration |
| 30 | 5 V Calibration |

COMMUTATOR FORMAT FOR MUMP 10

| Segment No. | Segment Assignment |
|-------------|--------------------------------------|
| 1 | Omegatron Range |
| 2 | OUT/D |
| 3 | Filament Voltage |
| 4 | Emission Current Monitor |
| 5 | Omegatron Bias Voltage Monitor |
| 6 | RF Amplitude |
| 7 | CD Regulated Voltage |
| 8 | Internal Pressure Monitor |
| 9 | Thermistor - Gauge Temperature |
| 10 | Thermistor - Amplifier Temperature |
| 11 | Thermistor - Transmitter Temperature |
| 12 | Thermistor - CD Temperature |
| 13 | Thermistor - Spare |
| 14 | Battery Voltage Monitor |
| 15 | Open |
| 16 | Open |
| 17 | Open |
| 18 | Open |
| 19 | Open |
| 20 | Open |
| 21 | Open |
| 22 | Open |
| 23 | Open |
| 24 | 0 V Calibration |
| 25 | 1 V Calibration |
| 26 | 2 V Calibration |
| 27 | 3 V Calibration |
| 28 | 4 V Calibration |
| 29 | 5 V Calibration |
| 30 | 5 V Calibration |

6. ANALYSIS OF DATA

The telemetered data were recorded on magnetic tape at the Wallops Island Main Base and the Goddard Space Flight Center Station A ground station facilities. Appropriate paper records were made from the magnetic masters, facilitating "quick look" evaluations. The aspect data were reduced to engineering parameters from paper records. The omegatron and housekeeping data were reduced by computer techniques from the magnetic tapes.

6.1. TRAJECTORY AND ASPECT

The position and velocity data used to determine aspect, ambient N_2 density, and ambient temperature as a function of time and altitude were obtained by fitting a smooth theoretical trajectory to the radar data (FPQ-6 and FPS-16 for MUMP 9; FPQ-6, FPS-16, and MPS-19 for MUMP 10). The theoretical trajectory is programmed for computer solution similar to that described by Parker (1962). The analysis of minimum angle of attack (α_{\min}) as described by Carter (1968) is also incorporated in the program. The output of the computer furnishes α_{\min} , altitude, and velocity as a function of time. Plots of α_{\min} versus altitude have already been given in Figures 14 and 15. Figures 16 and 17 show the occurrence of significant events during the flights.

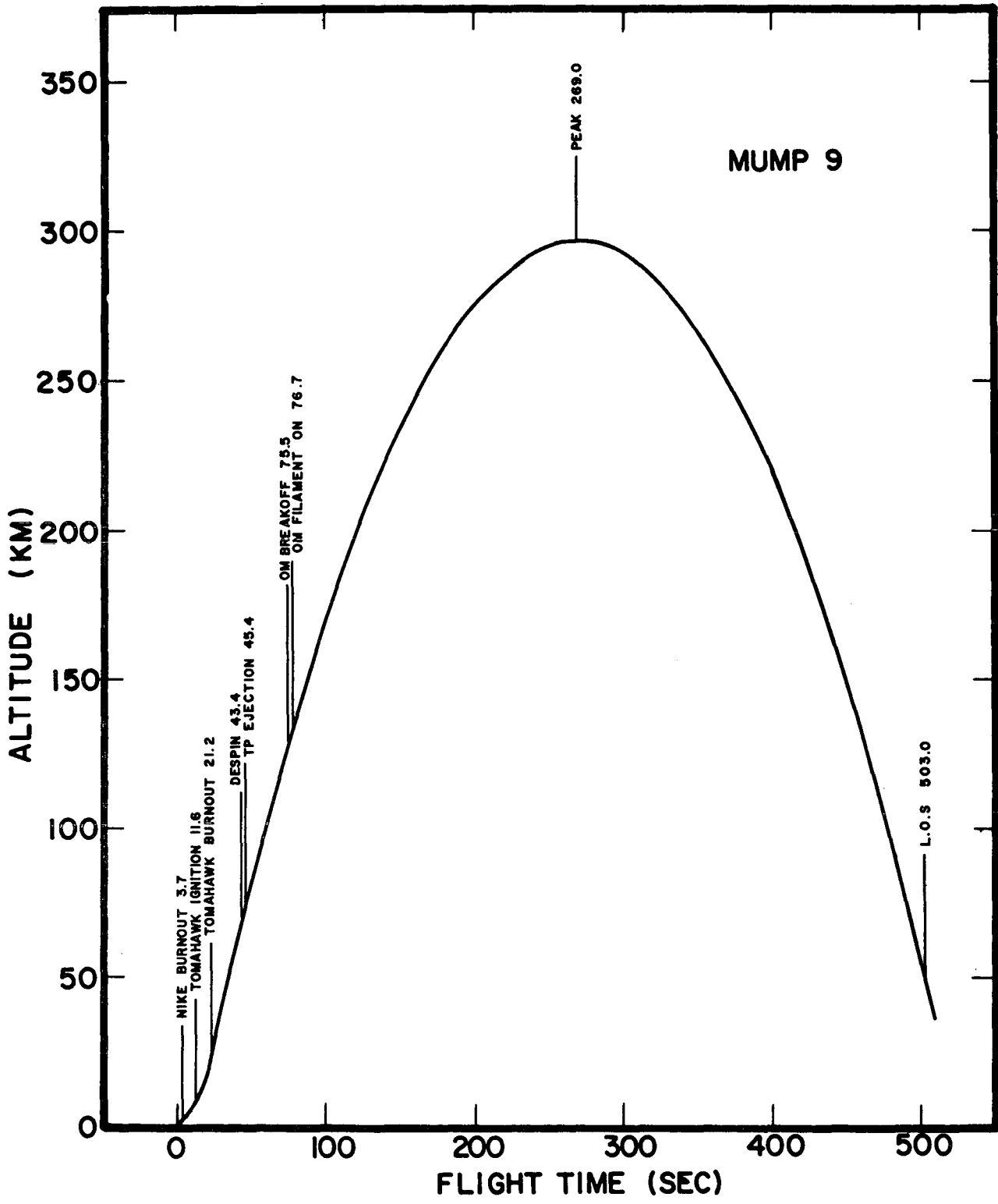

Figure 16. MUMP 9 sequence of events.

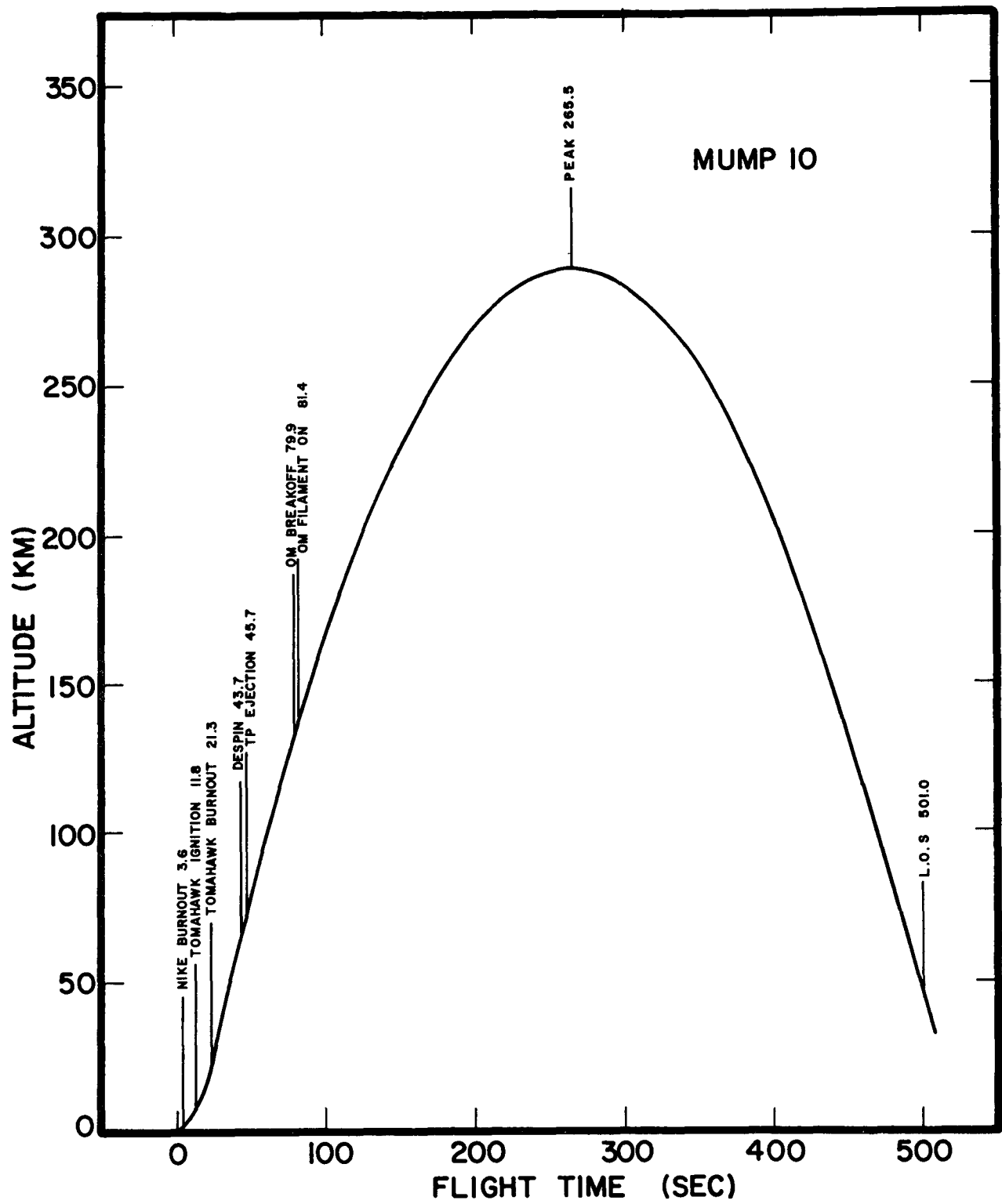

Figure 17. MUMP 10 sequence of events.

6.2. AMBIENT N₂ DENSITY

The neutral molecular nitrogen density was determined from the measured gauge partial pressure as described by Spencer, et al. (1965, 1966), using the basic relationship:

$$n_a = \left[\frac{\Delta n_i u_i}{2 \sqrt{\pi} V \cos \alpha_{\min}} \right] K(S_o, \alpha)$$

where

n_a = ambient N₂ number density

Δn_i = maximum minus minimum gauge number density during one tumble, $A \times \Delta I$, where A is the sensitivity of the gauge

u_i = $\sqrt{2KT_i/m}$, most probable thermal speed of particles inside gauge

T_i = gauge wall temperature

V = vehicle velocity with respect to the earth

α_{\min} = minimum angle of attack for one tumble

$K(S_o, \alpha)$ = the reciprocal of the normalized transmission probability as defined by Ballance (1967), referred to as the geometry correction factor.

ΔI , the difference between the maximum (peak) omegatron gauge current and the minimum (background) gauge current versus flight time is shown in Figures 18 and 19. The background current is the result of the outgassing of the gauge walls, and the inside density is due to atmospheric particles which have enough translational energy to overtake the payload and enter the gauge. The outgassing component is assumed constant for one tumble and affects both the peak reading and the background reading, and, therefore, does not affect the difference. From calibration data obtained by standard techniques, the inside number density, Δn_i , is computed for the measured current.

By using the measured gauge wall temperature, the most probable thermal speed of the particles inside the gauge, u_i , is computed. The uncertainty in this measurement is believed to be about $\pm 2\%$ absolute.

V , the vehicle velocity with respect to the earth is obtained from the trajectory curve fitting described previously and is believed to be better than $\pm 1\%$ absolute.

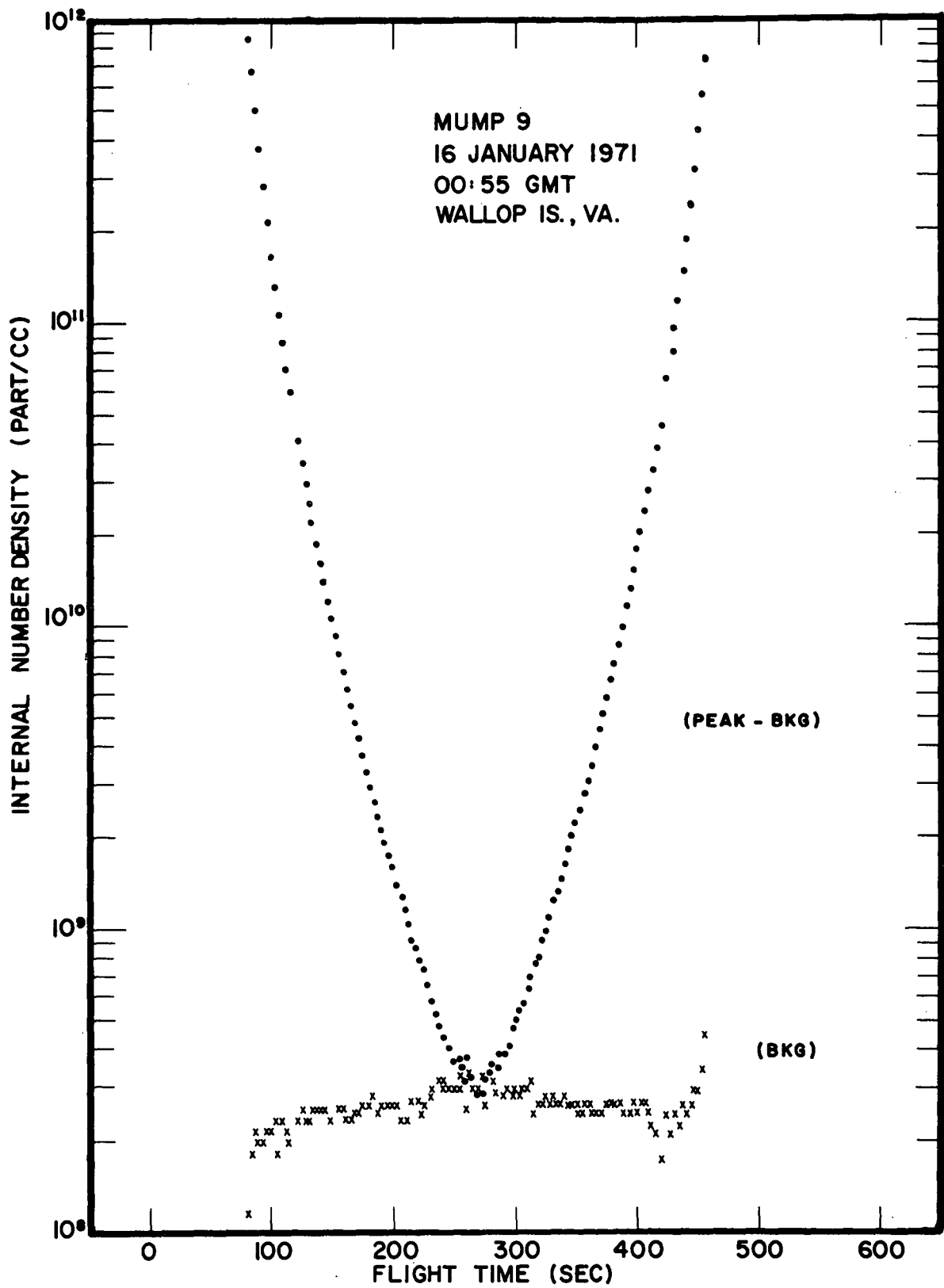

Figure 18. MUMP 9 omegatron current vs. flight time.

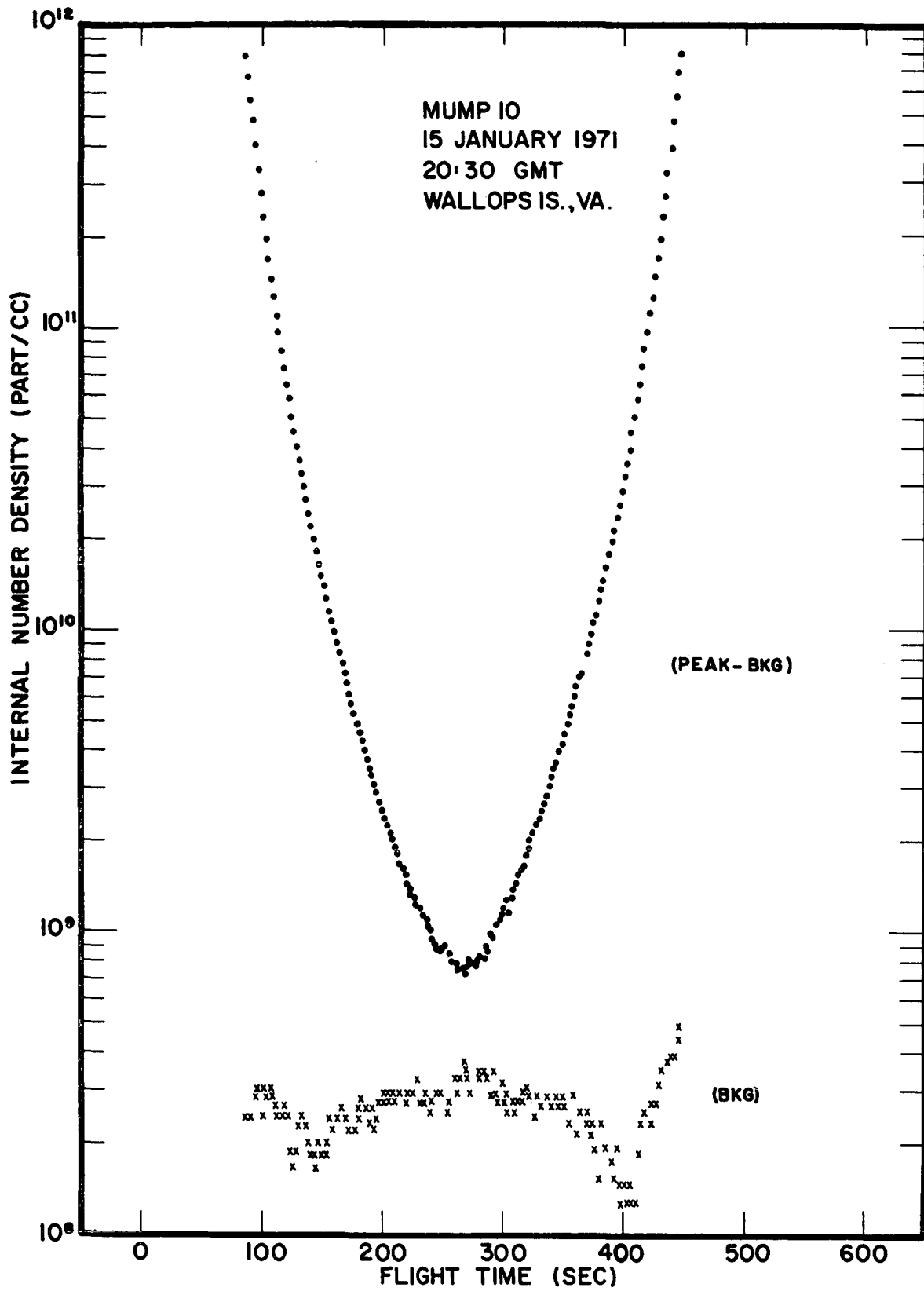

Figure 19. MUMP 10 omegatron current vs. flight time.

$\cos \alpha_{\min}$ is obtained from the aspect analysis described by Carter (1968). Since the uncertainty in $\cos \alpha_{\min}$ depends upon α_{\min} , for any given uncertainty in α_{\min} , each particular case and altitude range must be considered separately. Figures 14 and 15 show that the minimum angle of attack for the upleg is generally less than 10 degrees, so with an assumed maximum uncertainty in α_{\min} of ± 5 degrees, the resulting uncertainty in $\cos \alpha_{\min}$ is less than $\pm 2\%$. The data for low angle of attack were used as control data.

$K(S_0, \alpha)$, the geometry correction factor versus altitude, is shown in Figures 20 and 21. As can be seen, the maximum correction is about 12%, or $K(S_0, \alpha) = .88$ at about 145 km altitude for the upleg data. The correction factor, determined from empirical and theoretical studies, is believed known to better than 2%.

The resulting ambient N_2 number density, obtained from the measured quantities described above, is shown in Figures 22 and 23 and is tabulated in Table III. The uncertainty in the ambient density due to the combined uncertainties in the measured quantities is thought to be 10% relative and 25% absolute.

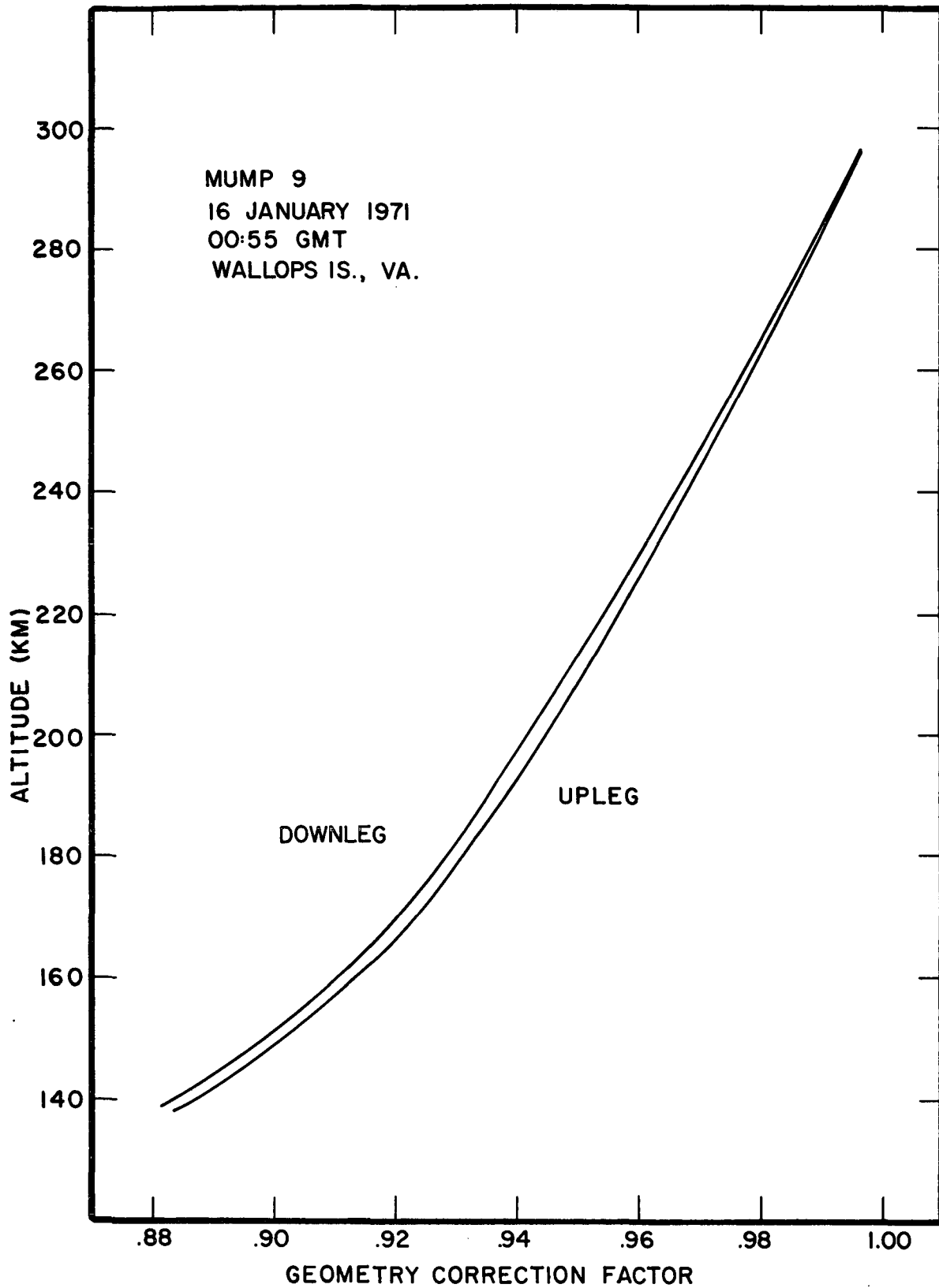

Figure 20. $K(S_0, \alpha)$ vs. altitude for MUMP 9.

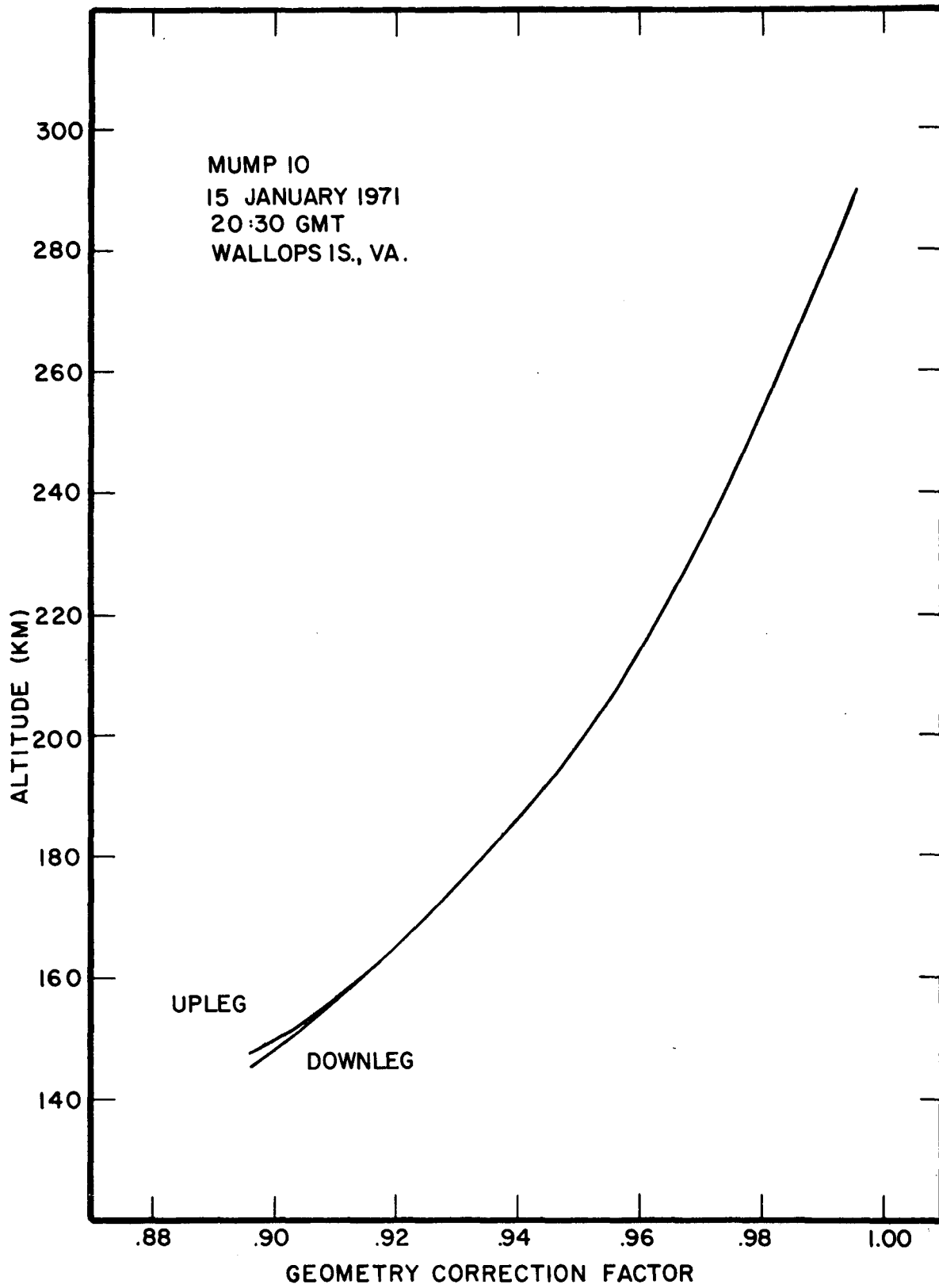

Figure 21. $K(S_0, \alpha)$ vs. altitude for MUMP 10.

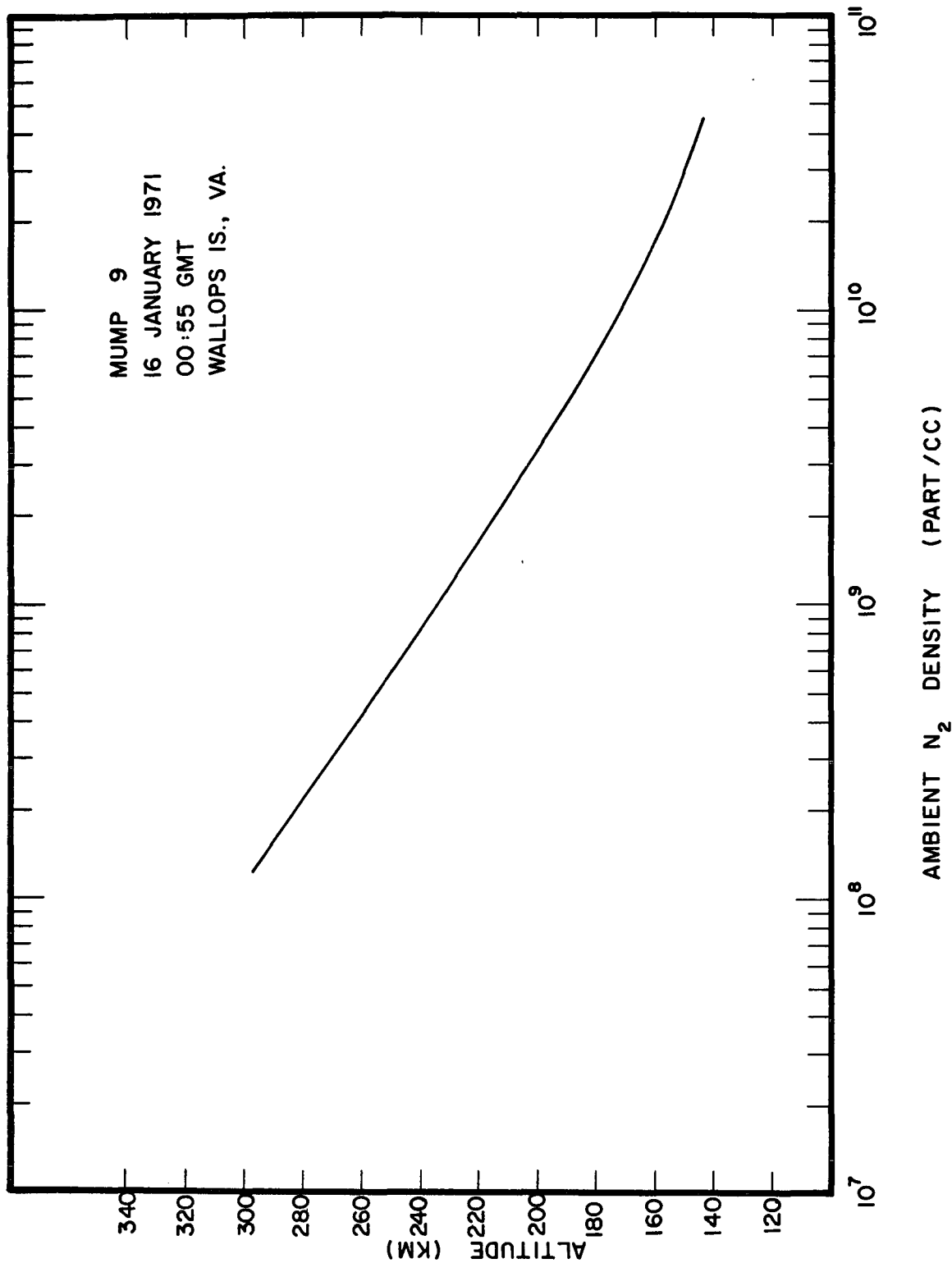

Figure 22. MUMP 9 ambient N₂ density vs. altitude.

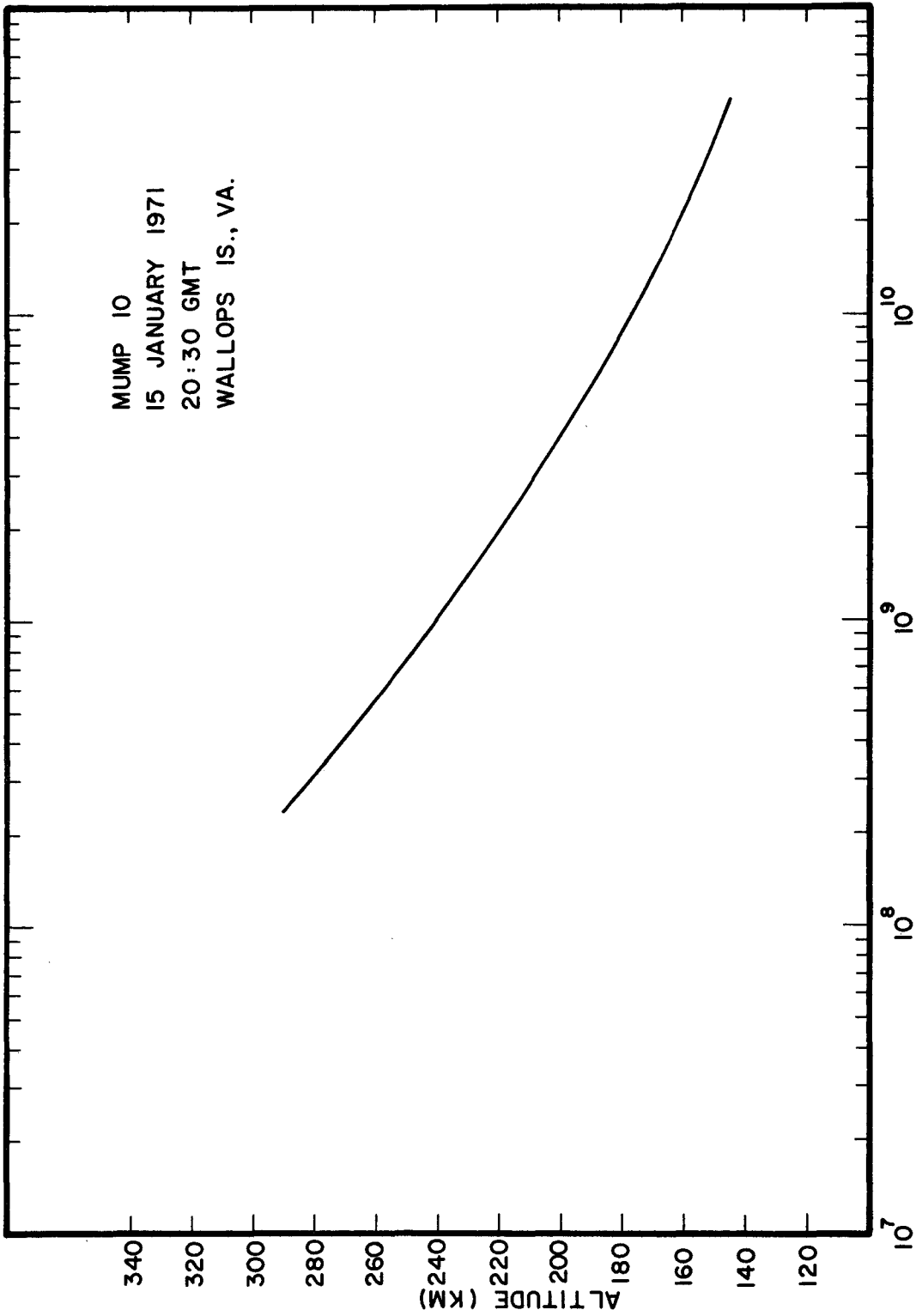

Figure 23. MUMP 10 ambient N₂ density vs. altitude.

Table III

N₂ AMBIENT DENSITY DATA

MUMP 9
 16 January 1971
 00:55 GMT
 15 January 1971
 19:55 EST

Wallops Island, Virginia

| Altitude (km) | Temperature (°K) | Density (part/cc) |
|------------------|---------------------|-------------------------|
| 143.5 | 632 | 4.11 x 10 ¹⁰ |
| 145 | 644 | 3.75 |
| 150 | 688 | 2.78 |
| 155 | 729 | 2.10 |
| 160 | 769 | 1.61 |
| 165 | 804 | 1.26 |
| 170 | 837 | 1.00 x 10 ¹⁰ |
| 175 | 861 | 8.10 x 10 ⁹ |
| 180 | 881 | 6.62 |
| 185 | 895 | 5.46 |
| 190 | 904 | 4.55 |
| 195 | 910 | 3.81 |
| 200 | 914 | 3.20 |
| 205 | 915 | 2.70 |
| 210 | 917 | 2.28 |
| 215 | 918 | 1.92 |
| 220 | 920 | 1.62 |
| 225 | 921 | 1.37 |
| 230 | 923 | 1.16 x 10 ⁹ |
| 235 | 923 | 9.78 x 10 ⁸ |
| 240 | 924 | 8.27 |
| 245 | 925 | 7.00 |
| 250 | 926 | 5.93 |
| 255 | 926 | 5.02 |
| 260 | 926 | 4.25 |
| 265 | 927 | 3.60 |
| 270 | 927 | 3.05 |
| 275 | 927 | 2.59 |
| 280 | 928 | 2.20 |
| 285 | 928 | 1.86 |
| 290 | 928 | 1.58 |
| 295 | 928 | 1.34 |
| 297 | 928 | 1.26 x 10 ⁸ |

Fit Parameters: $T_{\infty} = 928.17^{\circ}\text{K}$
 $T_0 = 629.98^{\circ}\text{K}$ at 145 km
 $P_b = 1.29 \times 10^{-8}$ torr
 $\sigma = 4.80 \times 10^{-2}$

TABLE III (Concluded)

MUMP 10

15 January 1971

20:30 GMT

15:30 EST

Wallops Island, Virginia

| <u>Altitude</u> (km) | <u>Temperature</u> (°K) | <u>Density</u> (part/cc) |
|-------------------------|----------------------------|-----------------------------|
| 145 | 651 | 4.69×10^{10} |
| 150 | 686 | 3.51 |
| 155 | 719 | 2.68 |
| 160 | 751 | 2.07 |
| 165 | 782 | 1.62 |
| 170 | 811 | 1.28 |
| 175 | 839 | 1.03×10^{10} |
| 180 | 866 | 8.31×10^9 |
| 185 | 890 | 6.76 |
| 190 | 912 | 5.54 |
| 195 | 932 | 4.57 |
| 200 | 950 | 3.80 |
| 205 | 966 | 3.17 |
| 210 | 982 | 2.66 |
| 215 | 996 | 2.24 |
| 220 | 1009 | 1.90 |
| 225 | 1020 | 1.62 |
| 230 | 1031 | 1.38 |
| 235 | 1041 | 1.18 |
| 240 | 1049 | 1.01×10^9 |
| 245 | 1058 | 8.64×10^8 |
| 250 | 1065 | 7.43 |
| 255 | 1072 | 6.40 |
| 260 | 1078 | 5.53 |
| 265 | 1084 | 4.77 |
| 270 | 1089 | 4.13 |
| 275 | 1094 | 3.58 |
| 280 | 1098 | 3.10 |
| 285 | 1101 | 2.69 |
| 289.6 | 1104 | 2.39×10^8 |

Fit Parameters: $T_{\infty} = 1143.4^{\circ}\text{K}$
 $T_0 = 779.84^{\circ}\text{K}$ at 165 km
 $P_b = 2.6788 \times 10^{-8}$ torr
 $\sigma = 1.8051 \times 10^{-2}$

6.3. NEUTRAL PARTICLE TEMPERATURE

The ambient temperatures shown in Figures 24 and 25 and tabulated in Table III were obtained by integrating the hydrostatic equation using the measured N_2 density profile to obtain a partial pressure profile, and by relating the known density and pressure to the temperature through the ideal gas law. In this procedure the assumptions of hydrostatic equilibrium and perfect gas behavior are implicit. It can be shown that the density integral is stable and highly convergent when carried out in the direction of increasing density. The pressure or temperature at the initial (upper) boundary of integration is determined analytically by means of a least squares fitting procedure using a fitting function based on the empirical expression for the temperature profile given by Jacchia (1964), and more particularly by Walker (1965). The procedure is described in detail by Simmons (1969). The fit parameters listed in Table III are the apparent exospheric temperature (T_∞), the reference temperature at the lower boundary (T_0), the apparent N_2 partial pressure at the upper boundary (P_b), and an estimate of the exponential model shape factor (σ).

6.4. ELECTRON TEMPERATURE AND DENSITY

The cylindrical Langmuir probe technique used in MUMP 10 has been described a number of times before (e.g., Spencer, et al., 1965; Taeusch, et al., 1968), and will not be discussed here. The charged particle results for MUMP 10 are shown in Figure 26 and tabulated in Table IV. MUMP 9 did not include the instrument.

6.5. GEOPHYSICAL INDICES

The 10.7 cm solar flux ($F_{10.7}$) and the geomagnetic activity indices (a_p) for the appropriate periods are shown in Figures 27 and 28.

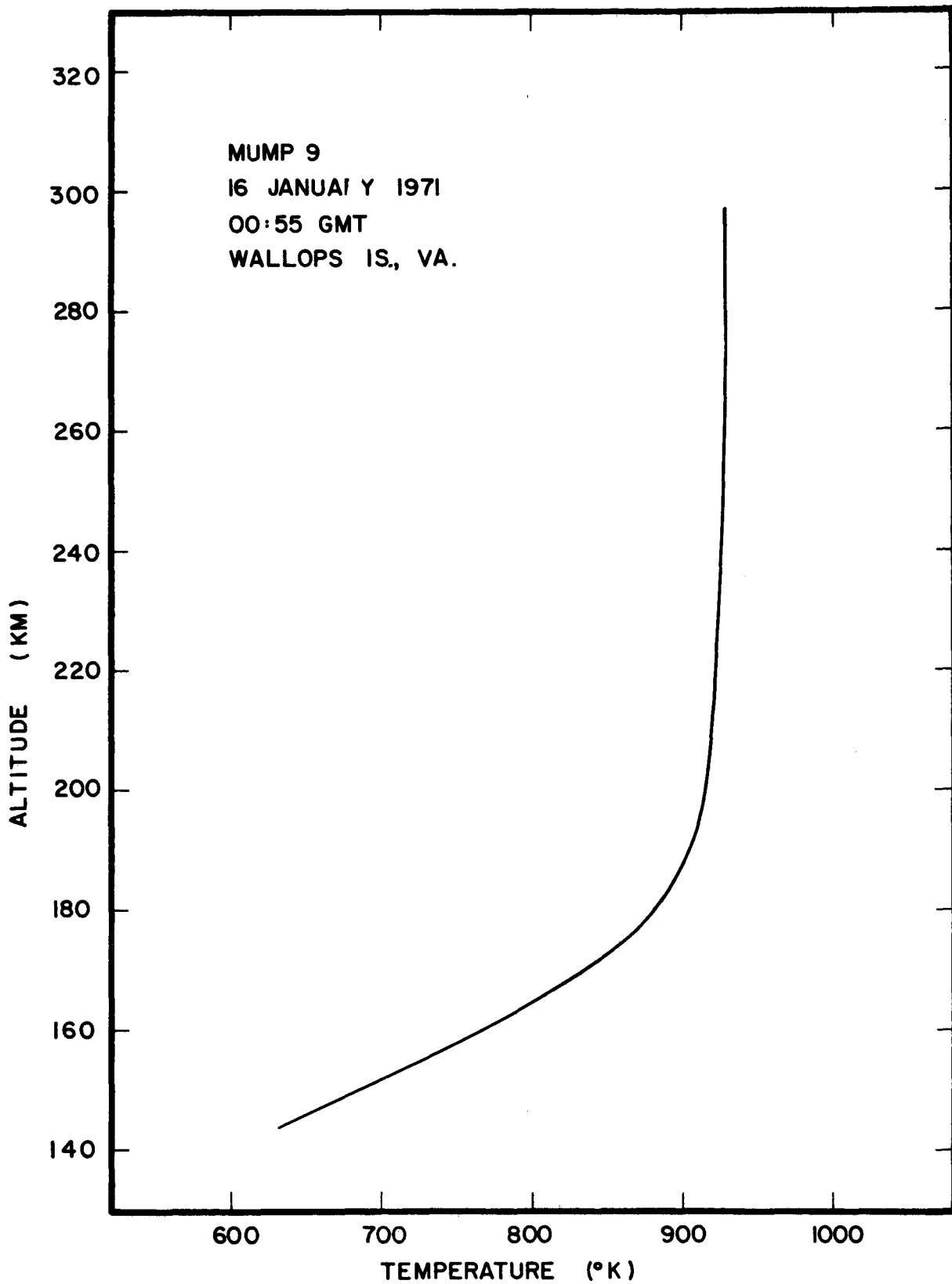

Figure 24. MUMP 9 neutral particle temperature vs. altitude.

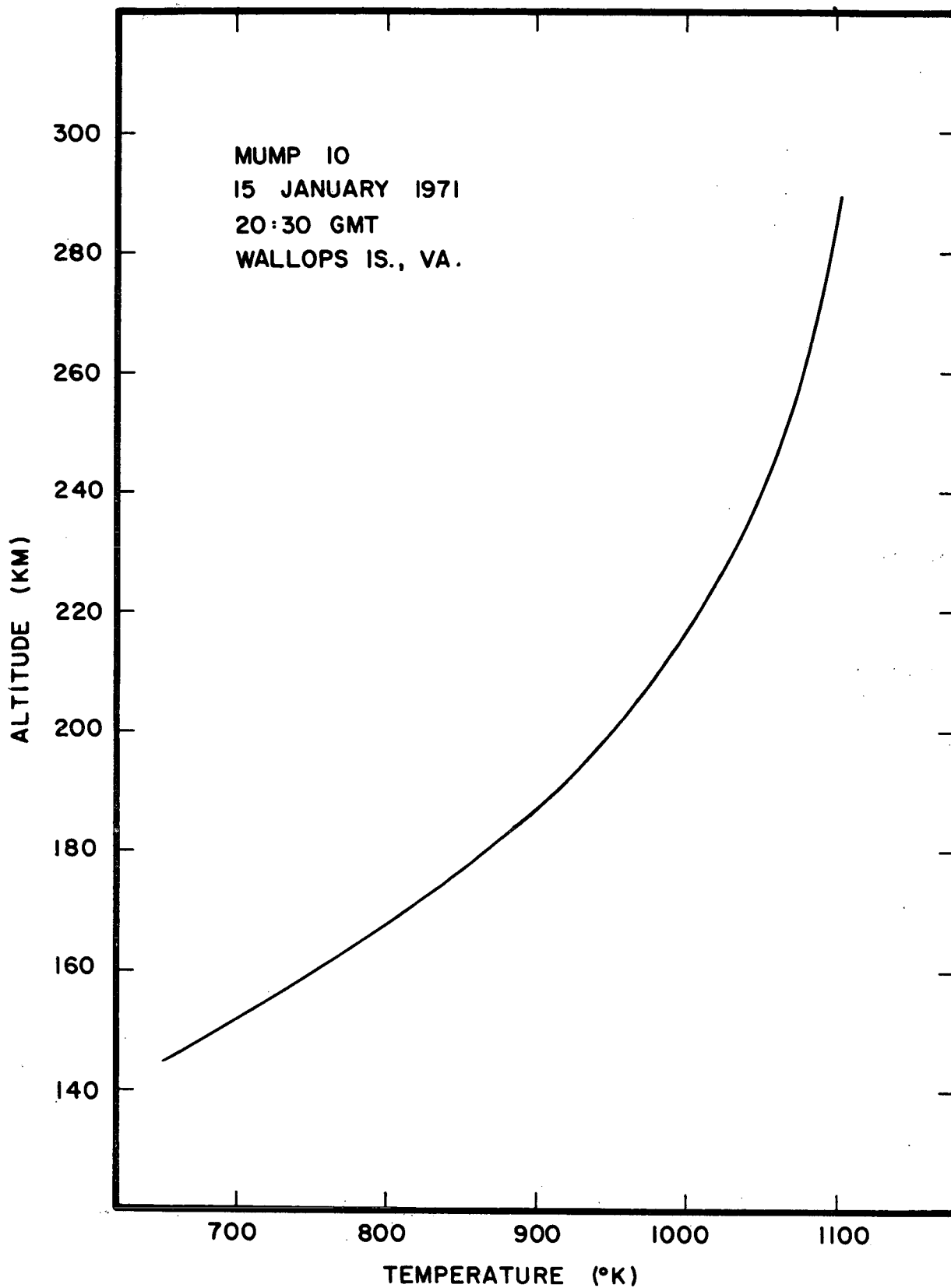

Figure 25. MUMP 10 neutral particle temperature vs. altitude.

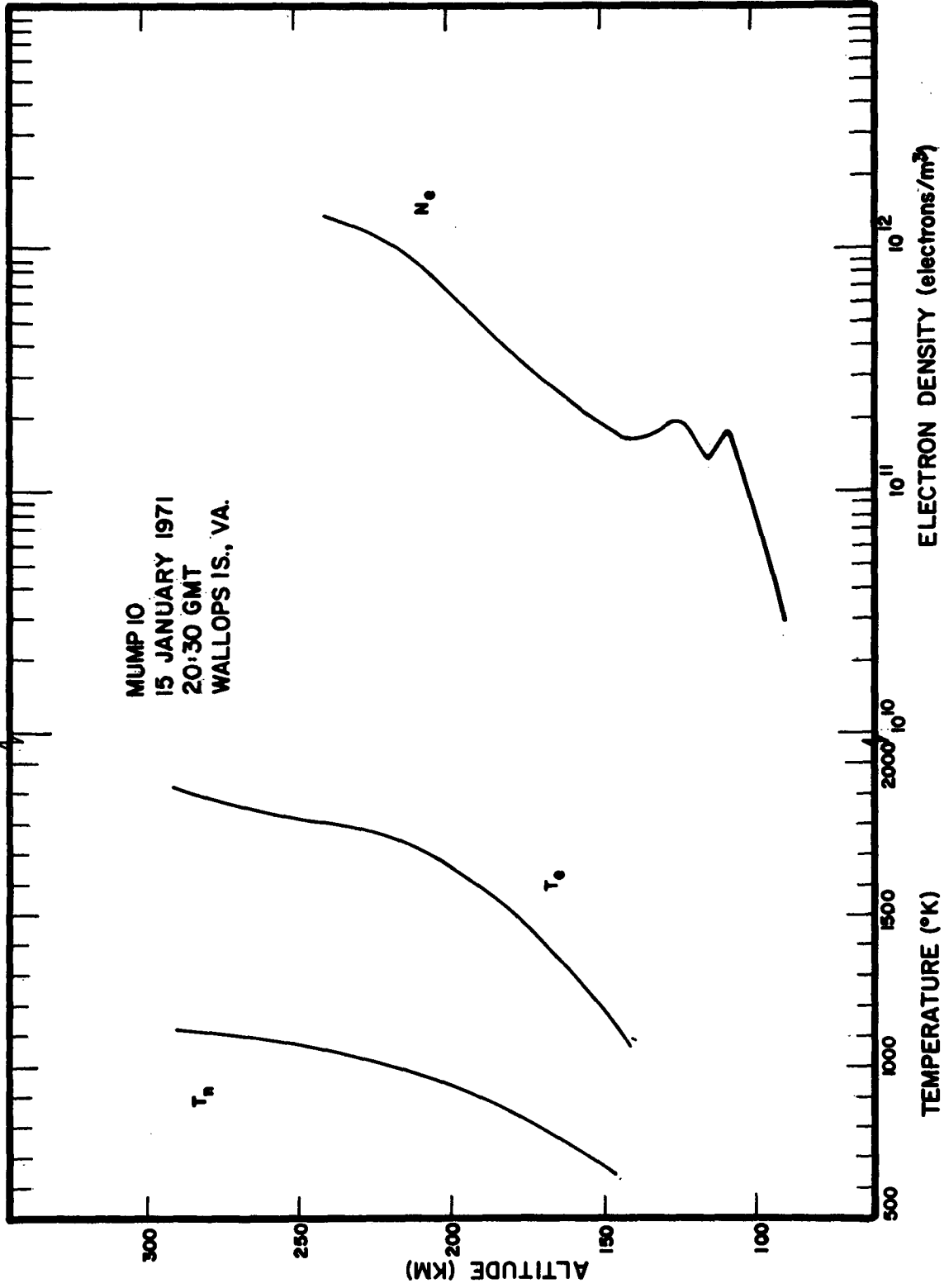

Figure 26. Charged particle results for MUMP 10.

TABLE IV

CHARGED PARTICLE RESULTS

MUMP 10
15 January 1971
20:30 GMT

Wallops Island, Virginia

| <u>Altitude</u> (km) | <u>T_e</u> (°K) | <u>N_e</u> (electrons/m ³) |
|-------------------------|------------------------------|---|
| 90 | | 2.95 x 10 ¹⁰ |
| 100 | | 8.00 x 10 ¹⁰ |
| 110 | | 1.70 x 10 ¹¹ |
| 120 | | 1.71 |
| 130 | | 1.82 |
| 140 | 1065 | 1.67 |
| 150 | 1203 | 1.92 |
| 160 | 1322 | 2.38 |
| 170 | 1424 | 2.99 |
| 180 | 1516 | 3.85 |
| 190 | 1597 | 5.03 |
| 200 | 1666 | 6.82 |
| 210 | 1721 | 8.90 x 10 ¹¹ |
| 220 | 1760 | 1.09 x 10 ¹² |
| 230 | 1788 | 1.24 |
| 240 | 1808 | 1.37 x 10 ¹² |
| 250 | 1820 | |
| 260 | 1840 | |
| 270 | 1865 | |
| 280 | 1894 | |
| 289.6 | 1923 | |

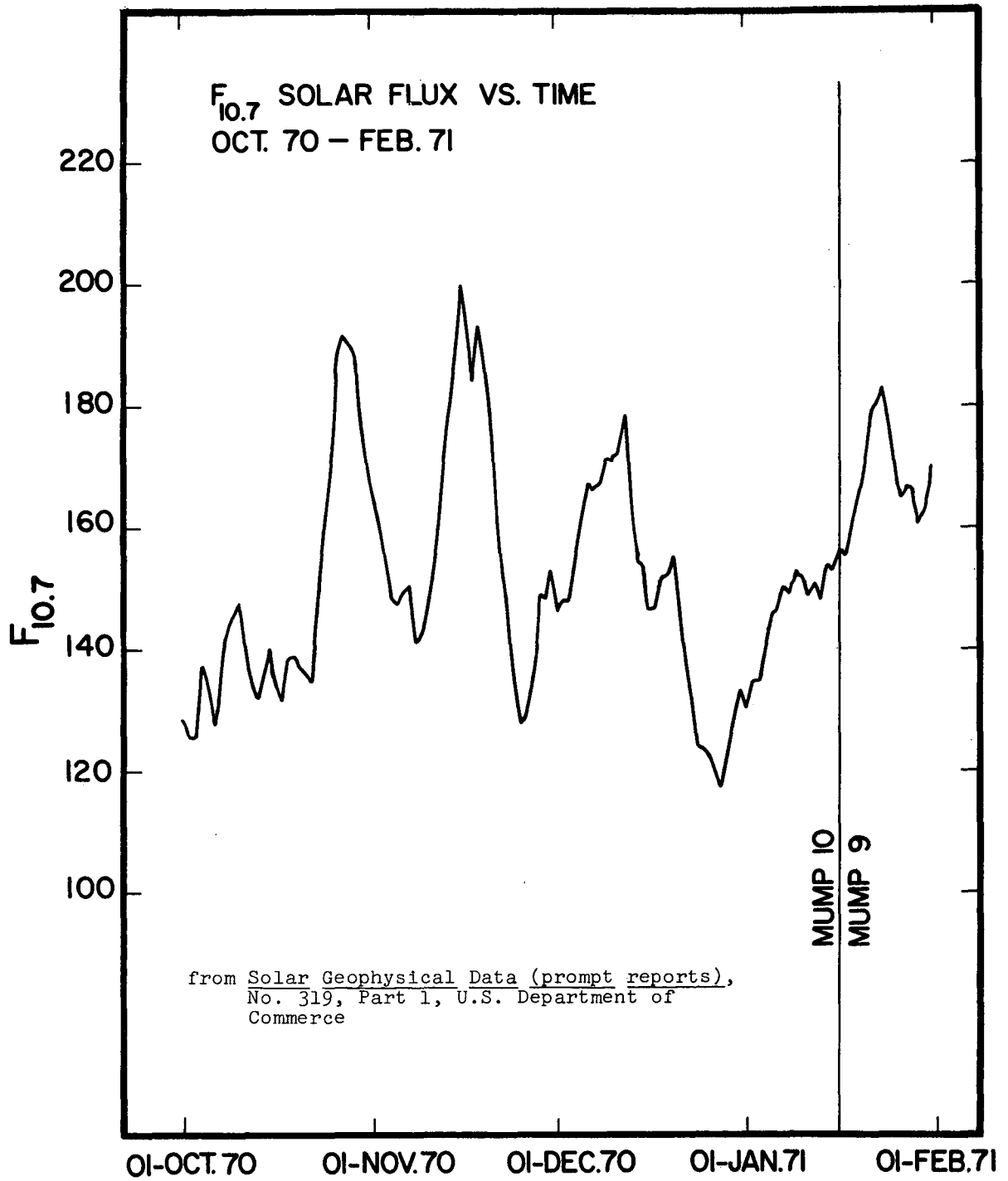

Figure 27. Solar flux at 10.7 cm wavelength.

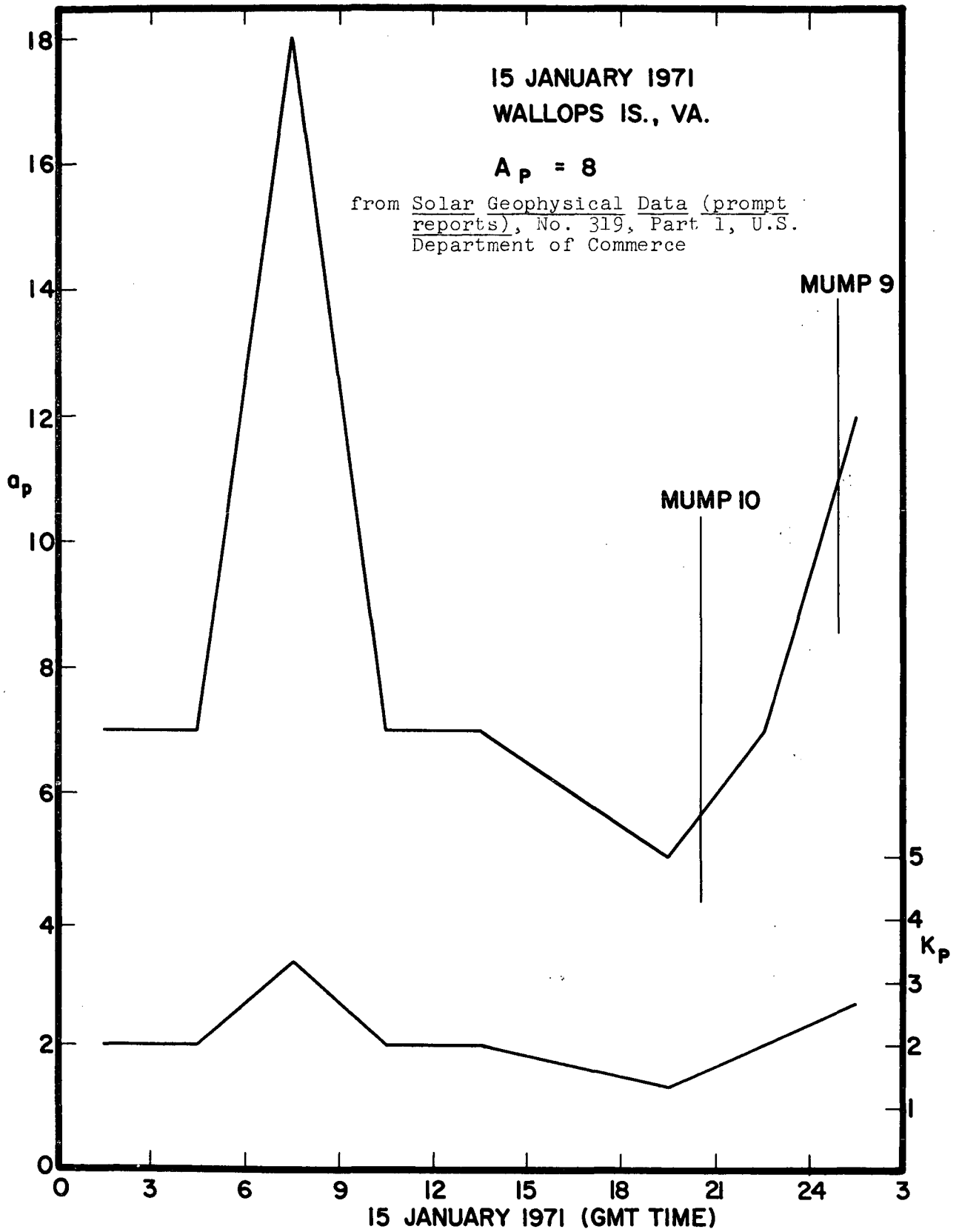

Figure 28. Three-hour geomagnetic activity index (a_p).

7. REFERENCES

- Ballance, James O., An Analysis of the Molecular Kinetics of the Thermosphere Probe, George C. Marshall Space Flight Center, NASA Technical Memorandum, NASA TM X-53641, July 31, 1967.
- Carter, M. F., The Attitude of the Thermosphere Probe, University of Michigan Scientific Report 07065-4-S, April 1968.
- Jacchia, L. G., Static Diffusion Models of the Upper Atmosphere with Empirical Temperature Profiles, Research in Space Science, Smithsonian Astrophysical Observatory Special Report No. 170, 1964.
- Niemann, H. B., and Kennedy, B. C., "An Omegatron Mass Spectrometer for Partial Pressure Measurements in Upper Atmosphere," Review of Scientific Instruments, 37, No. 6, 722, 1966.
- Parker, L. T., Jr., A Mass Point Trajectory Program for the DCD 1604 Computer, Technical Document Report AFSW-TDR-49, Air Force Special Weapons Center, Kirtland Air Force Base, New Mexico, August 1962.
- Simmons, R. W., NASA 18.49 Thermosphere Probe Experiment, University of Michigan Sounding Rocket Flight Report 07065-9-R, May 1969.
- Spencer, N. W., Brace, L. H., and Carignan, G. R., "Electron Temperature Evidence for Nonthermal Equilibrium in the Ionosphere," Journal of Geophysical Research, 67, 151-175, 1962.
- Spencer, N. W., Brace, L. H., Carignan, G. R., Tausch, D. R., and Niemann, H. B., "Electron and Molecular Nitrogen Temperature and Density in the Thermosphere," Journal of Geophysical Research, 70, 2665-2698, 1965.
- Spencer, N. W., Tausch, D. R., and Carignan, G. R., N₂ Temperature and Density Data for the 150 to 300 Km Region and Their Implications, Goddard Space Flight Center, NASA Technical Note X-620-66-5, December 1965.
- Tausch, D. R., Carignan, G. R., Nagy, A. F., and Niemann, H. B., Diurnal Survey of the Thermosphere (Final Report), NASA Contractor Report CR-61481, NASA-George C. Marshall Space Flight Center, Huntsville, Alabama, November 1968.

7. REFERENCES (Concluded)

Taeusch, D. R., Carignan, G. R., Niemann, H. B., and Nagy, A. F., The Thermosphere Probe Experiment, University of Michigan Rocket Report 07065-1-S, March 1965.

Walker, J. C. G., "Analytic Representation of Upper Atmosphere Densities Based on Jacchia's Static Diffusion Models," Journal of Atmospheric Sciences, 22, No. 4, 462-463, July 1965.