

OPTIMAL ASCENT TRAJECTORIES OF A TWO STAGE SPACE SHUTTLE VEHICLE

by R. A. Wilson
Space Division, North American Rockwell Corporation
Downey, California

INTRODUCTION

The Space Shuttle concept offers an interesting option to the traditional launch performance optimization problem in that the shuttle stages are equipped with lifting surfaces designed to withstand significant normal forces. Therefore, a natural question would be whether or not lift can substantially improve performance, thereby lowering total program costs.

Preliminary results obtained with the Phase B "piggy-back" configuration indicated at least quantitatively a potential 15% improvement in performance through the use of lift during mated ascent. Consequently, it is necessary to continually assess the importance of lift as the shuttle evolution progresses.

STUDY OBJECTIVE

(Figure 1)

The objective of this study is to determine the effects of lift on performance of a current space shuttle concept.

Groundrules necessary for the performance evaluation include: 1) Polar launch to a 50 x 100 nautical mile insertion; 2) Main propellant loadings are fixed for comparative purposes since off-loading the stages would result in an unnecessary payload loss; 3) Optimal steering is restricted to the pitch plane only; 4) The product of $q - \alpha$ is unconstrained, whereas axial load is limited to 3 g's in both stages and is achieved by throttling the main engines. The objective is to maximize performance for the given configuration.

STUDY OBJECTIVE

- DETERMINE EFFECTS OF LIFT ON PERFORMANCE CAPABILITY OF A TYPICAL SHUTTLE CONFIGURATION

GROUND RULES

- POLAR LAUNCH TO INSERTION AT 50 NAUTICAL MILES
- ASCENT PROPELLANT LOADINGS FIXED IN BOTH STAGES
- OPTIMAL STEERING RESTRICTED TO THE PITCH PLANE
- $q - \alpha$ UNCONSTRAINED
- AXIAL LOAD LIMITED TO THREE G'S
- MAXIMIZE PAYLOAD FOR GIVEN CONFIGURATION

Figure 1

PROGRAM DESCRIPTION

(Figure 2)

The performance program used in this analysis uses three-degrees-of-freedom to describe the trajectory of a point mass moving over a spherical rotating earth. The optimal thrust-vector angle (the angle between the free stream velocity vector and the thrust vector) is specified by the calculus of variation method. Other unique features of the program include the determination of booster flyback propellant requirements which are a function of staging conditions, and the thrust gimbal angle required to balance the aerodynamic moment. Thrust gimbal angle is referenced to the vehicle centerline such that during mated flight the thrust is generally vectored slightly above the reference axis whereas after separation the orbiter thrust is always pointing below the vehicle centerline. Vehicle aerodynamic coefficients are input in the body axis system and are a function of angle of attack and Mach number. Since the study purpose is to evaluate performance under nominal conditions, winds have been excluded. However, the effect of winds on performance and loads is a significant factor to consider in vehicle design.

PROGRAM DESCRIPTION

- 3 DOF EQUATIONS OF MOTION, SPHERICAL, ROTATING EARTH
- PARTICLE MASS
- OPTIMAL THRUST ATTITUDE SPECIFIED BY CALCULUS OF VARIATION METHOD
- BOOSTER FLYBACK PROPELLANT REQUIREMENTS DETERMINED FROM STAGING CONDITIONS
- AERO MOMENT BALANCED BY THRUST VECTOR
- AERO COEFFICIENTS FUNCTION OF ANGLE OF ATTACK & MACH NUMBER
- NO WINDS

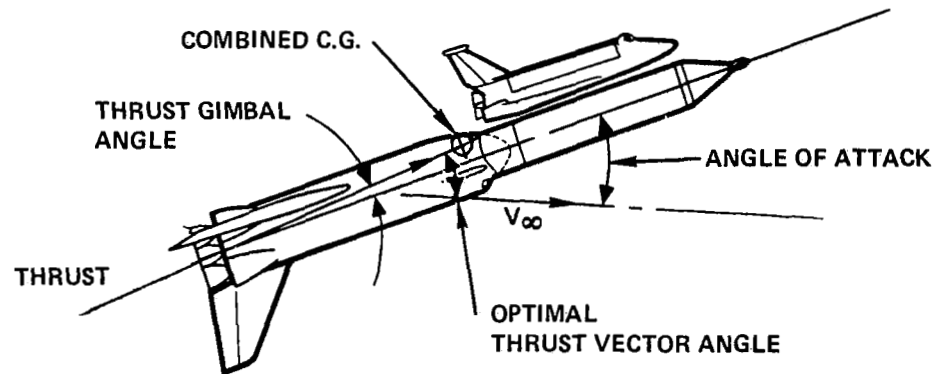

Figure 2

STUDY CONFIGURATION

(Figure 3)

The configuration selected for this study is representative of one of the shuttle concepts currently under investigation. This configuration consists of a reusable flyback booster and a tandem mounted all external tank orbiter. Both stages use liquid oxygen/liquid hydrogen for main ascent propellant. The orbiter main engines which are ignited at separation are canted approximately 8 degrees below the vehicle centerline in order to minimize the gimbal requirements during ascent to orbit.

STUDY CONFIGURATION

(AS OF SEPTEMBER 1, 1971)

GLOW = 3,111,000 (LBS), 1,411,000 KG

$(T/W)_O = 1.3$

STAGING CONDITIONS

ALTITUDE, (FT), KM (190,000), 57.9

VELOCITY, (FPS), M/SEC (7,000), 2134

FLIGHT PATH ANGLE, DEG 13

ITEM	BOOSTER	ORBITER
GROSS STAGE WEIGHT, (K LB), KG	(2141), 971,000	(970), 440,000
ASCENT PROPELLANT, (K LB), KG	(1757), 797,000	(721), 327,000
SEA LEVEL THRUST, (K LB) KN	(4044), 17,990	-
VACUUM THRUST, (K LB), KN	(4441), 19,754	(1148), 5,106
VACUUM I_{sp} , SEC	439	453.2
ENTRY WEIGHT, (K LB), KG	(368), 167,000	(130), 59,000
NUMBER OF ENGINES	12	3

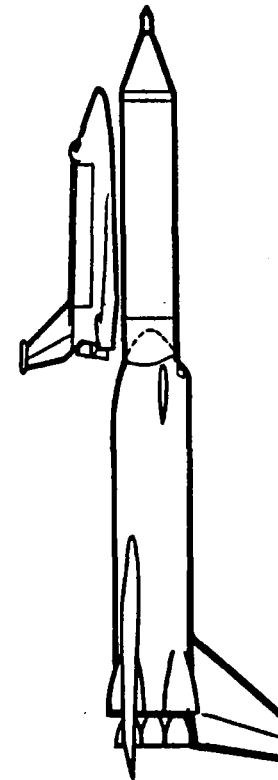

Figure 3

BASIC ASCENT MODES

(Figure 4)

The method for evaluating the effects of lift consisted of comparing the performance of two ascent modes. Case 1 represents the conventional zero alpha flight mode in which the vehicle ascends vertical for 10 seconds and subsequently performs a pitch-over maneuver for the next 20 seconds. From 30 seconds to staging the vehicle flies at zero angle-of-attack. After staging optimal thrust attitude steering directs the orbiter to insertion. Case 2 differs from case 1 in that optimal thrust attitude steering is prescribed from 30 seconds to orbit insertion.

BASIC ASCENT MODES

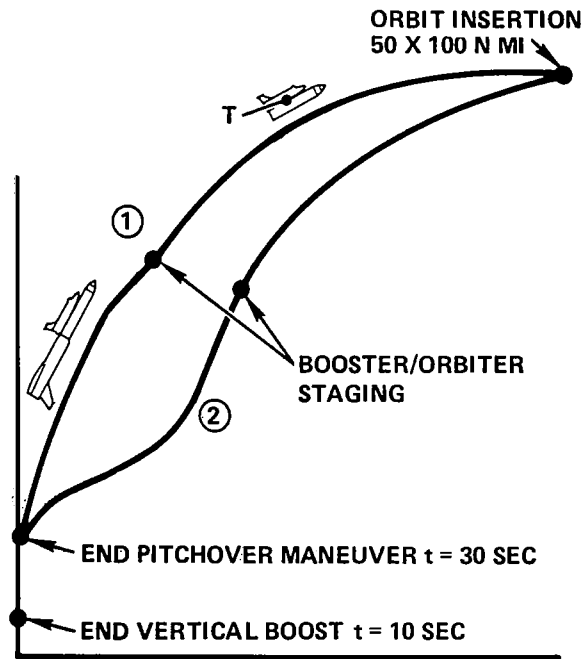

- EVENT
- CASE ①
 - VERTICAL BOOST FOR TEN SECONDS
 - PERFORM PITCHOVER MANEUVER FOR TWENTY SECONDS
 - ZERO ANGLE OF ATTACK POLICY TO STAGING
 - OPTIMAL PITCHPLANE STEERING TO INSERTION
- ② ● SAME AS CASE 1 FOR FIRST THIRTY SECONDS
 - OPTIMAL ANGLE OF ATTACK POLICY TO ORBIT INSERTION

Figure 4

ANGLE OF ATTACK TIME HISTORIES

(Figure 5)

Time histories of the angle of attack and thrust vector angle requirements are illustrated in this graph for the two flight modes. Note that the thrust angle requirements during orbiter burn do not represent actual gimbal requirements since the main orbiter engines are canted approximately 8 degrees below the vehicle centerline. As a result of this offset center of gravity, and the optimal thrust angle requirements, the angles-of-attack that the orbiter sees are quite large initially. This does not imply significant aerodynamic loads since dynamic pressure is relatively low at staging and continues to decrease to orbit insertion.

The thrust vector angle requirements during mated ascent of +2 degrees are attributed to the combined c.g. being essentially on the vehicle centerline.

THRUST VECTOR ANGLE & ANGLE OF ATTACK VS TIME FROM LIFT-OFF

CASE 1 ZERO ANGLE OF ATTACK

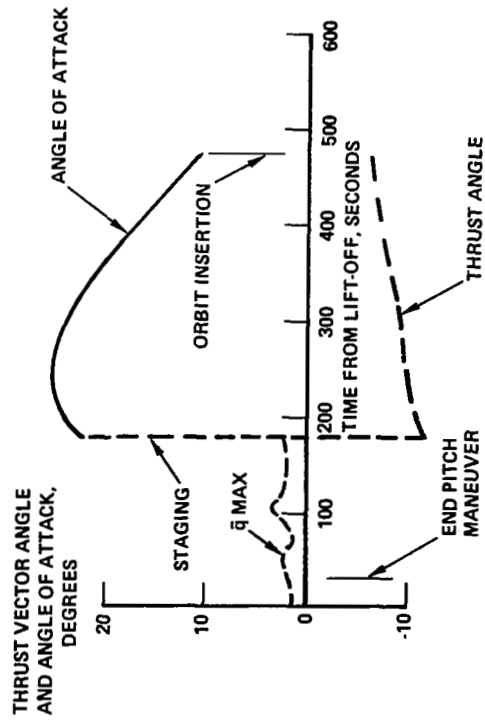

THRUST VECTOR ANGLE & ANGLE OF ATTACK VS TIME FROM LIFT-OFF

CASE 2 OPTIMAL STEERING

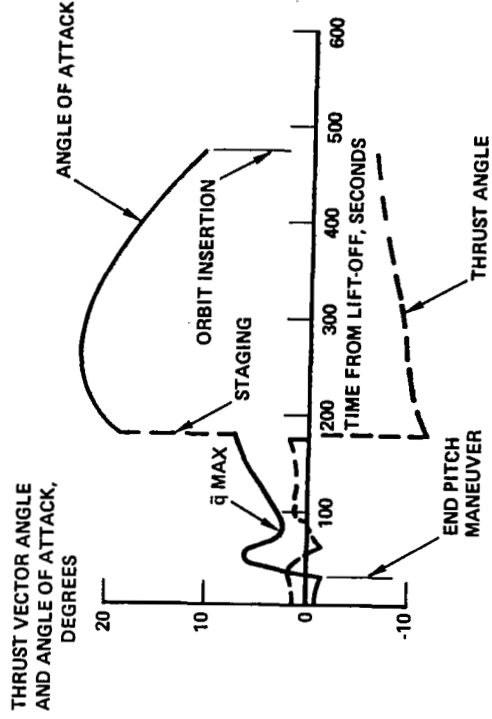

Figure 5

PERFORMANCE RESULTS

(Figure 6)

The performance results are summarized for the ascent modes investigated.

The zero alpha mode, case 1, resulted in a payload of 41,000 pounds with a corresponding maximum dynamic pressure of 518 psf and zero maximum $q - \alpha$ for a no wind condition. Case 2 resulted in a 2,000 pound performance gain over case 1; however, the maximum \bar{q} increased to 644 psf and the product of $q - \alpha$ reached a maximum of 2711 psf degrees. No assessment of the effect of winds on loads was conducted. Nevertheless, it is anticipated that some structural redesign would be necessary to account for increased loads. Thus the potential advantage of mode 2 over mode 1 would diminish or completely disappear.

PERFORMANCE RESULTS

CASE	ALPHA POLICY	Q _{MAX} /Q- α MAX (PSF)/(PSF-DEG) N/M ² /N/M ² -DEG	STAGING CONDITION			PAYLOAD (LBS) KG
			h (FT) KM	γ (DEG)	V (FT/SEC) M/SEC	
1	α = 0 TO BOOSTER BURNOUT; OPTIMAL STEERING TO ORBIT INSERTION	(518)/(0) 24,802/0	(188,200) 57.4	13.0	(7085) 2160	(41,000) 18,600
2	OPTIMAL STEERING TO ORBIT INSERTION	(644)/(2711) 30,835/129,800	(182,400) 55.6	15.4	(7158) 2182	(43,000) 19,500

Figure 6

1101

CONCLUSIONS

(Figure 7)

Optimal steering, mode 2, provides a small potential performance gain (approximately 5%) compared to a zero angle-of-attack mode. However, it is expected that the structural weight increase required to withstand increased loads due to winds would offset this potential gain. Consequently, this configuration does not appear to merit further investigation of the use of lift. Finally, significant improvements in performance through the use of lift appear to be configuration dependent, therefore the effects of lift cannot be generalized based on the results of this study.

CONCLUSIONS

- OPTIMAL STEERING RESULTS IN A POTENTIAL PERFORMANCE GAIN (2000 POUNDS) COMPARED TO A ZERO ALPHA ASCENT FOR THIS CONFIGURATION
- HIGHER MAX q - α WOULD RESULT IN STRUCTURAL WEIGHT INCREASE WHICH OFFSET POTENTIAL GAIN
- BENEFITS OF LIFT CANNOT BE GENERALIZED DUE TO CONFIGURATION DEPENDENCY

Figure 7