

**NASA TECHNICAL
MEMORANDUM**

NASA TM X- 68042

NASA TM X- 68042

**CASE FILE
COPY**

400 KILOWATT ARGON ARC LAMP FOR SOLAR SIMULATION

by Arthur J. Decker and John L. Pollack
Lewis Research Center
Cleveland, Ohio

TECHNICAL PAPER proposed for presentation at
Sixth Space Simulation Conference sponsored by the
Institute of Environmental Sciences, the American
Institute of Aeronautics and Astronautics, and the
American Society for Testing and Materials
New York, New York, May 1-4, 1972

400 KILOWATT ARGON ARC LAMP FOR SOLAR SIMULATION

by Arthur J. Decker and John L. Pollack

Lewis Research Center

SUMMARY

E-6875

A 400 kilowatt argon arc lamp for a solar simulator has been designed, operated, and evaluated at Lewis Research Center. The lamp is designed to produce one solar constant on a test area 4.6 by 9.2 meters when used with a collimator. The divergence angle of the beam is about 1° . The lamp is designed to operate completely within a vacuum environment.

Over 80 kilowatt of directed radiation was monitored and measured for a 25-hour period during a recent test. In another test, an arc was operated at 400 kilowatt for 110 hours without removal or refurbishing of the electrodes. These tests have proven the cleanliness and integrity of the radiation source.

The arc lamp in its tested configuration will produce one solar constant when used with an argon arc of approximately 425 kilowatt. The temporal fluctuation of the irradiance from the lamp is $\pm 1/2$ percent indicating a very steady source. The source is expected to produce a very uniform beam since it superimposes 124 channels of radiation. This expectation is reinforced by a scan of part of the beam with a solar cell. The scan shows that the irradiance varies by less than 1 percent.

The spectrum of the radiation is that of an argon arc. The spectrum has been altered by two mirrors and two lenses. It can be summarized as follows. Normalize all the radiation falling between 0.25 and 2.7 micrometers to 130 milliwatts per square centimeter. The irradiance then has the following distribution:

Wavelength interval, μm	Irradiance, mW/cm^2
0.25 to 0.40	15.5
.40 to .70	38.8
.70 to 1.0	38.0
1.0 to 2.7	37.7

INTRODUCTION

The Lewis Research Center operates the largest space environment facility in the world. Its Plum Brook space chamber measures 30.5 meters in diameter and 39.6 meters in height. The chamber has vacuum and cold wall capability. To complete the space chamber a large solar simulator was designed and built at Lewis. The design guidelines included (a) large test volume - up to 9.2- by 9.2-meters of cross sectional area and up to 15.2 meters of axial depth, (b) the entire simulator to operate in a vacuum environment, and (c) ground level service to all components. The goal of the solar simulator was state-of-the-art performance in stability, divergence angle, and uniformity of radiation.

This paper describes the solar simulator and summarizes the design, operation, and performance of the key component - a 400 kilowatt argon arc lamp. The lamp is a pressurized sealed unit containing the electrodes of the argon arc and the optics. We monitored and measured over 80 kilowatts of directed radiation for a 25-hour period in a recent test. This radiation is sufficient to produce 0.9 solar constant on a test area 4.6 by 9.2 meters (one solar constant is equal to 135.3 mW/cm^2). The 25-hour test proved the cleanliness and integrity of the radiation source. Longest electrode life to date is 110 hours.

THE SOLAR SIMULATOR

The Plum Brook space chamber solar simulator (fig. 1) uses an off axis optical system and collimated radiation. Two 400 kilowatt lamps are positioned near the wall at floor level. The optics within the sealed lamps project a beam of radiation to a bifurcated collimator mirror suspended from the ceiling. Each half of the mirror measures 5.2 by 10.4 meters. To satisfy the irradiance requirement of one solar constant over a 42-square meter area and account for an edge loss, we require about 90 kilowatts of directed radiation from each source. The

mirror halves direct the individual beams to form a 9.2- by 9.2-meter test area 30.5 meters from the mirrors.

Arrangement of the Optics

The optics shown in figures 2(a) and (b) consist of:

(1) A radiation collection system composed of a parabolic collector, 19.0 centimeter focal length (FL), and a spherical mirror, 92 centimeter radius of curvature (RC).

(2) A transfer system composed of two arrays, each containing 124 fused-silica, plano-convex lenses (18.5 cm RC), magnesium fluoride overcoated, and called by names such as lenticular plates, optical integrators, and mixers. Their use in solar simulators is described in references 1 and 2.

(3) A spherical collimating mirror (61 m RC).

The center of the arc is at the focus of the paraboloid. The radiant intensity distribution seen by the collectors is shown in figure 3. The paraboloid collects arc radiation between angles of 40° and 113° . An auxiliary spherical mirror can be placed between 113° and 135° . It reflects radiation back through the arc toward the paraboloid. The data reported, however, does not involve the use of the spherical mirror.

The collimated radiation reflected from the paraboloid impinges on the lower lens array. The optical centerline of each lens in this array is parallel to the optical axis of the paraboloid and co-incident with the optical centerlines of the upper lens array. The lower lens array serves two optical functions: First, each lower lens forms an image of the arc in the plane of the upper lens array; and second, prisms of varying wedge angles on the lenses shift the positions of the arc images. (Not shown in figs. 2(a) and (b).) Because of the variation of parabola magnification, the inner lenses produce images which are too large to be transmitted completely through the upper lenses. The prisms position the brightest portion of the arc for maximum throughput.

The upper lens array is located in the focal plane of the collimator. The optical function of the upper lens array is as follows: First, each individual upper lens projects an image of its lower counterpart to infinity. In figure 2(a) the collimator re-images the lower lens A sharply as a rectangle A' 30.5 meters from the collimator. Second, wedges on the upper lenses bring into registration the 124 individual beams from the lower lenses. This registration occurs at the collimator in the plane of figure 2(a). The rays from the left edge of each lower lens in figure 2(a) all intersect at B at the collimator. The wedges are on the plano side of the upper lenses.

Figure 2(b) shows a plane at right angles to the plane of figure 2(a). In figure 2(b) registration occurs in the test area. The rays from the left edge of each lower lens are deviated by the collimator and all intersect at C at the edge of the test area.

This variation of registration uses the radiation from the source more efficiently with the bifurcated collimator.

The collimator at its focal distance from the upper lens array projects a "sun" consisting of 124 arc images to infinity. The divergence angle of the beam is about 1° . The collimated radiation permits constant irradiance with depth in the test volume.

Collimator Fabrication

The collimator with each arc lamp consists of 40 hexagons of 5083 aluminum. Each hexagon is 1.4 meters between sides and has a mass of 136 kilograms. Each hexagon is suspended at three points from a truss which in turn is suspended from the chamber ceiling. The mirror blanks are obtained fully annealed and of a nonprecipitable alloy. Each blank is 1.6 meters in diameter and 5 centimeters thick. The blanks are machined parallel to a thickness of 3.8 centimeters and contoured to a 61 meter radius of curvature on a vertical boring mill. Polishing and figuring with both dry and wet silicon carbide papers (150 to 600 grit) is next. During this stage, the mirrors are checked with a 30.5 centi-

meter spherometer and a 12.7 centimeter diameter gage block. Machining the hexagonal shape and the mounting holes is next. The mirror is then flow coated about 13 micrometers thick, with an alkyd melamine to make it specular.

The coating takes place in a tank oriented 20° from the vertical. The bubble-free solution is introduced from the bottom and completely covers the mirror. The solution then drains from the bottom at a rate of 2.5 centimeters per minute. The flow coated mirror is cured at 422 K for 1 hour. Then the mirror is aluminized and overcoated with SiO_x .

Surface accuracy as measured with a Foucault test is better than 1 minute. The total argon specular reflectance of the finished mirror is approximately 82 percent.

Lamp Design

A fundamental consideration of the design of the sealed 400 kilowatt lamp was simplicity. The optical surfaces were kept few in number by designing multiple functions for all components. The lamp is shown in figure 4 and sketched in figure 5. The lamp housing is a slightly tapered cone joined to the parabolic collector and the upper lens plate. Its diameter is approximately 2 meters and its height is 1.5 meters. The lamp is a stainless steel pressure vessel designed to operate at 10 atmospheres internal pressure and to dissipate 0.5 megawatt of rejected power. The lamp is held together by a 2 meter diameter ring 7.6 centimeters thick. The ring is supported by two pivoting arms which cradle in the floor supports. The ring has four struts, 3.8 centimeters wide, running through the 1.2 meter diameter opening to the center hub. The hub holds the anode. The struts furnish the cooling water and the electrical ground.

The 1.2 meter aperture paraboloid, shown in figure 6, is a part of the pressure vessel and bolts to the ring. An "O" ring seal is machined into its mounting flange. Four slots are machined into the rim of the

collector to accommodate the struts. This collector is a 2.5 centimeter thick spinning of 5083-O aluminum, electrodeless nickel-plated inside and out, water-cooled outside, and polished and figured to 5 minute surface accuracy. The mirror is aluminized and overcoated with SiO_x . Its average reflectance for an argon spectrum is 85 percent. At the vertex of the paraboloid is a 22.8 centimeter hole and a mounting flange. The movable, water-cooled cathode assembly bolts to this flange.

The auxiliary collector shown sitting on the shelf above the paraboloid is still in fabrication. Its accuracy and construction are similar to the parabola. It will add about 5 percent to the useful radiation projected from the lamp.

The lower lens array shown in figure 7 is centered and supported by a post. Small water tubes are fixed to the edges of the lens supports. Water enters from a plenum on one side and exits on the opposite side. The rectangular lenses which measure 7.1 by 12.5 centimeters rest on pins which pass through the lens dividers.

The upper lens plate is 1.5 meters in diameter and 10.8 centimeters thick. It is made from 17-4 PH stainless steel (fig. 8). Its purpose is to keep the gas in and let radiation out. One hundred twenty-four pockets were electric discharge machined on a 9.6 centimeter pitch spacing. Twenty-eight 0.64 centimeter diameter holes were deep drilled (up to 1.5 m deep along the dia.) to serve as cooling passages. Each 3.2 centimeter thick diamond-shaped lens was 9.6 centimeters on a side. It had an "O" ring groove ground into the edge and a 0.76 centimeter wide recessed step ground onto the face to seat the lens. The lenses are designed to withstand a 10 atmosphere pressure load while transmitting 2 kilowatts of radiation. The lenses are retained on the pressure side by a water-cooled guard capable of supporting a 1 atmosphere pressure differential. This guard also shields the "O" ring from scattered radiation. The maximum temperature measured on the lens near the "O" ring was 394 K.

THE ARC AND THE ELECTRODES

Electrodes

The most difficult goal to achieve has been the development of long-lived electrodes for the arc. Both the anode and the cathode absorb a large heat load. At 400 kilowatts, the anode absorbs more than 120 kilowatts and the cathode absorbs more than 20 kilowatts. However, a pair of electrodes has been operated without removal or refurbishing for more than 110 hours at 400 kilowatts of arc power.

The general cooling and design features of the electrodes have been described in references 3 to 5. The electrodes presently used in the arc lamp are shown in the photographs in figure 9. A sectioned diagram of the anode is shown in figure 10. A sectioned diagram of the cathode is shown in figure 11.

The anode shown in figure 10 is smaller, and has slightly different cooling features, than the anodes described in the references. The maximum anode diameter is only 8.9 centimeters. The arc attaches to a demountable, spherical cap of radius 5.08 centimeters. The anode blocks less radiation from the arc than do the larger anodes described in the references.

The cooling passages of the anode are rectangular in cross section. A rectangular cooling passage has an advantage over a cooling passage with a circular cross section. The wetted perimeter effective in cooling is about 15 percent greater for a square cross section of the same diameter as the circular cross section.

The maximum temperature of the water-cooled surfaces of the anode are less with rectangular passages. Of course, the length-to-hydraulic diameter ratio of the rectangular cooling passage must be less than about 10. Otherwise, the laminar boundary layer which forms in the corners of the passage will grow too large.

The cooling water enters the anode at 6.89×10^6 newtons per meter squared (1000 psig) and leaves the anode at 3.1×10^6 newtons per meter squared (450 psig). The anode requires about 0.01 cubic meter per

second (160 gal/min) of cooling water. The velocity of the water in the cooling passages reaches a maximum of about 61 meters per second (200 ft/sec). The high inlet pressure keeps the boiling temperature of the water greater than 477°K (400°F).

The removable anode cap is made from copper. The remainder of the anode can be made from copper, nickel, or stainless steel.

The cathode is geometrically identical with the cathode described in references 3 to 5. However, the cathode has operated for a longer time at higher power than mentioned in reference 4. A single cathode has operated for more than 110 hours at 400 kilowatts. This result was achieved by using thoriated tungsten from a different producer.

On the cathode, the arc attaches to the rim, and down inside, a 1.27 centimeter diameter crater. The crater is machined in a thoriated tungsten cap. The cap, in turn, is vacuum cast on the copper enclosing the water passage.

The cathode uses 6.3×10^{-3} cubic meters per second (100 gal/min) of cooling water. The inlet pressure is 6.2×10^6 newton per meter squared (900 psig) and the outlet pressure is 1.7×10^6 newton per meter squared (250 psig). Both the anode and the cathode are supplied with cooling water by a 0.04 cubic meter per second (600 gal/min), 8.3×10^6 newton per meter squared (1200 psig) centrifugal pump.

Cooling Water

The cooling water for the electrodes must be kept free of oxygen and dissolved solids. Otherwise, insulating oxides and other deposits form on the water-cooled surfaces of the electrodes.

The high pressure water system is completely enclosed making oxygen removal easy. The water is heated to 338°K (150°F) by running the high-pressure-water pump without its heat exchanger. Argon is bubbled through the water in a storage tank during the heating process. The space above the water in the tank is kept slightly above atmospheric pressure by venting the tank through a relief valve. The argon

displaces the air from this open space. In this way, the water is quickly deoxygenated and the oxygen content kept less than 1/2 part per million.

The 1.3 cubic meters (350 gal) of water in the high pressure system are kept low in dissolved solids by continuous demineralization. A 3.2×10^{-5} cubic meter per second (1/2 gal/min) demineralizer runs constantly in a bypass loop attached to the storage tank. The demineralizer keeps the resistivity of the water greater than 0.25 megohm-centimeters.

Arc

The electric arc in the lamp fixture is a free burning or electrode stabilized argon arc. The properties of this arc have been described in reference 5 for argon as well as for xenon and krypton. Typical, but not unique, operating conditions are summarized below.

The current is 3900 amperes and the voltage is 102.5 volts. This voltage and current give an arc power of 400 kilowatts.

The separation between the electrodes or the arc gap is 7.62 centimeters. The arc lamp originally was designed to use a 7.62 centimeter arc gap. The measured values of irradiance confirm that transmission through the optics is a maximum with a 7.62 centimeter arc gap and with the arc centered at the focus of the collector.

The pressure of the gas surrounding the arc is 3.5 to 3.6 atmospheres absolute. The overall transmission of radiation by the arc lamp improves slightly when pressure is increased with arc power held constant. There are two explanations for the increase. First, the narrower arc image at higher pressure is more completely transmitted through the second lens array of the arc lamp. Second, the radiation efficiency of the arc increases at higher pressure. Two total radiation detectors inside the arc lamp show a real increase in radiation output with a pressure increase. At 300 kilowatts, there is a 6 percent increase in test area irradiance when the operating pressure is changed from 3 to 4 atmospheres. Unfortunately, higher pressures increase the chance that the arc will change spontaneously from a desired diffuse attachment on the cathode to a destructive spot or multiple spot attachment.

Radiation from the 400 Kilowatt Arc

The polar distribution of radiant intensity from an argon arc at 350 kilowatts was reported in reference 5. The same kind of distribution is shown in figure 3 for the electrodes used in the arc lamp at 400 kilowatts. The origin of the plot of radiant intensity in figure 3 is a point midway between the electrodes. Angles are measured from the cathode direction. The units of radiant intensity are kilowatts per steradian per 100 kilowatts of input power.

At powers greater than 200 kilowatts, the argon arc is a very efficient radiator. Measurements of the rate of decay of pressure in the arc lamp upon extinguishing the arc show that the convective, conductive loss of energy from the arc is between 5 and 10 percent of input power. Efficiency does not vary much with power above 200 kilowatts. The best way to get more radiation from the arc is to decrease the size and blockage of the electrodes.

A comparison of reference 2 with figure 3 shows that the smaller anode now used in the arc lamp yields a 7 percent increase in the collectable radiation.

PERFORMANCE OF THE ARC LAMP

This section summarized measurements made while the arc lamp was operating. The measurements include the results of a 25 hour test with all the optical parts of the lamp in place.

The measurements are stated for the arc lamp as it would operate in the Plum Brook space chamber. However, the tests were performed, without a collimator, in a test cell at Lewis Research Center.

Test Cell

The test cell is over 30.5 meter long, 4.6 meters wide, and 5.3 meters tall. The cell is not wide enough or tall enough to accommodate the entire beam of radiation 30.5 meters from the arc lamp.

Without the collimator, registration of the 124 channels of radiation does not occur as it would in the solar simulator in the space chamber.

However, measurements of total irradiance, spectral irradiance, and stability of irradiance were made in part of the beam. In that part of the beam where the 124 channels overlap and are not obstructed, the uniformity of irradiance was checked.

The arc lamp is mounted vertically at one end of the test cell. A turning mirror projects the beam about 30.5 meters to the other end of the test cell. At this end of the test cell, there is a radiation scanner (fig. 12). The scanner can be moved into the unobstructed part of the beam for measurements of irradiance.

The scanner consists of 12 solar cells mounted 0.3 meter apart on a vertical strut. There is a total radiation detector at the center of the vertical strut. The strut can be moved horizontally with 0.3 stops over a 3 meter distance.

The turning mirror is made from collimator segments. Therefore, the reflection at the turning mirror introduces approximately the same total and spectral losses that would occur at the collimator.

Irradiance Against Power

Figure 13 is a typical graph of irradiance against arc power. As stated in a previous section of the report, the actual irradiance depends somewhat on the pressure in the arc lamp. At a constant power of 300 kilowatts, the irradiance increases by 6 percent when the pressure is increased from 3 to 4 atmospheres. The data point at 381 kilowatts was measured at a pressure of 3.26 atmospheres.

Spectrum

The spectrum of the radiation from the arc lamp and the collimator is tabulated in figure 14. For comparison, the figure also includes a spectrum of the same arc reported originally in reference 5. The com-

parison spectrum was measured at 325 kilowatts through an ultraviolet grade quartz window in a test chamber. The window was in a view port which pointed at the crater in the cathode. Hence, the comparison spectrum is of the brightest and hottest portion of the arc.

The spectrum of the radiation from the arc lamp is composed of radiation from all parts of the arc. This spectrum of the arc has been altered by reflections from the collector and collimator, and by transmission through two sets of lenses.

Both the spectrum from the chamber and the spectrum from the arc lamp were measured with the same filter radiometer. Both spectra show the power in a wavelength interval as a percentage of the total irradiance measured with the radiometer.

Stability of Irradiance

The long time stability of the arc lamp was measured during a 5 hour portion of a 25 hour run. The irradiance was stable within 1.1 percent. This result held even though the turning mirror degraded during the run. The turning mirror was originally designed for an irradiance of 2 solar constants. The mirror was subject to several hundred solar constants during the run.

The short time stability of the arc lamp was measured from the output of a solar cell. The root-mean-square fluctuation of the output of the solar cell was less than 1/2 percent of the dc level of the cell indicating a very stable source. In fact, the short time stability of the arc lamp appears limited by the stability of the power supply. The arc was powered by a 0 to 250 volt., 4000 ampere direct current generator with continuously variable voltage control. The generator is in series with a ballast resistor of 0.03 ohm. The effect of power supply noise on the stability of irradiance from the arc lamp is being investigated.

Uniformity of Irradiance

The measurement of the uniformity of irradiance in cross section and depth requires the installation of the arc lamp and the collimator in the Space Chamber. However, we did measure the output of individual solar cells as they were scanned across the beam. The variation in the output of a single solar cell was less than 1 percent. The scan was over 3 meters of the beam in 0.3 meter intervals. One hundred twenty-four channels of radiation should create this high degree of uniformity.

Power Absorbed by the Components of the Arc Lamp

Figure 15 lists the percentage of arc power dissipated in the components of the arc lamp. The data were measured with the arc operating at 380 kilowatts. These measurements are performed by measuring the water-flow-rate and temperature rise of the cooling water as it flows through a component. The measurements are accurate to about ± 10 percent.

The power not accounted for in the components of the lamp is approximately equal to the power radiated by the lamp. At 380 kilowatts, the power radiated is about 99 kilowatts. The directed radiation available from the arc lamp is about 80 kilowatts.

Degradation of Optical Parts During a 25 Hour Run

During the 25 hour run, there was no significant change in the reflectivity of the collector or the transmission factors of the lenses. This result confirmed a visual inspection of the inside of the arc lamp which showed a very clean interior after 25 hours of running.

CONCLUDING REMARKS

A 400 kilowatt argon arc lamp has been operated at Lewis Research Center. The arc lamp is the key component of a solar simulator to be

used in the large space chamber at Lewis' Plum Brook Station.

Tests of the arc lamp and the arc electrodes have shown that the solar simulator will meet its design goals. These goals include: an irradiance of one solar constant over a 9.2 by 9.2 meter area in the test volume; high uniformity and stability of irradiance; a divergence angle of about 1° ; ability to operate with integrity in a vacuum environment; and a long-lived and cleanly operating arc.

We intend to continue to improve the reliability and lifetime of the electrodes of the arc. We shall also upgrade and simplify servicing the arc lamp. Included will be automation of both the startup and operation of the lamp.

The final evaluation of the arc lamp as part of a solar simulator must be done in the Plum Brook Space Chamber.

REFERENCES

1. Bartera, R. E., Riise, H. N. and Miller, C. G., "Solar Simulators at the Jet Propulsion Laboratory," Applied Optics, Vol. 9, No. 5, May 1970, pp. 1068-1074.
2. Rantsch, K., "Illuminating System, Particularly for Projection Purposes," U.S. Patent 2,326,970, July 1, 1940.
3. Hall, J. H., Gettelman, C. C., Pollack, J. L., Goldman, G. C. and Decker, A. J., "High Powered Arc Electrodes," CASE-LEW-11162-1, U.S. Patent Application-SN-143508, Filed May 5, 1971, NASA, Cleveland, Ohio.
4. Hall, J. H., Gettelman, C. C., Pollack, J. L., Decker, A. J. and Goldman, G. C., "Durable Cathodes for High-Power Inert-Gas Arcs," Tech Brief 71-10264, 1971, NASA, Cleveland, Ohio.
5. Decker, A. J., Goldman, G. C. and Pollack, J. L., "Radiation Characteristics from High Power Noble Gas Arcs," The Environmental Challenge of the 70's, Institute of Environmental Sciences, Mt. Prospect, Ill., 1970, pp. 46-51.

L-6075

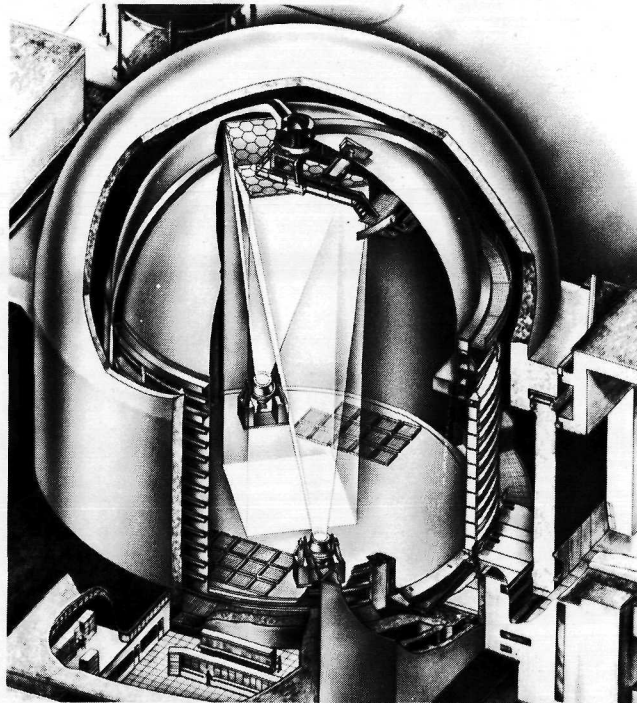

Figure 1. - Plumbrook Space Chamber.

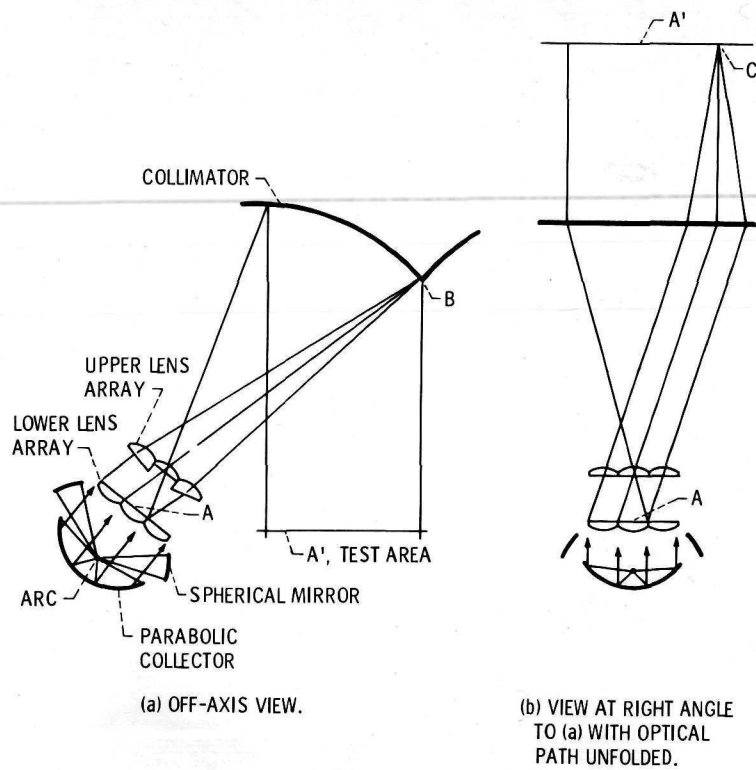

Figure 2. - Arrangement of the optics.

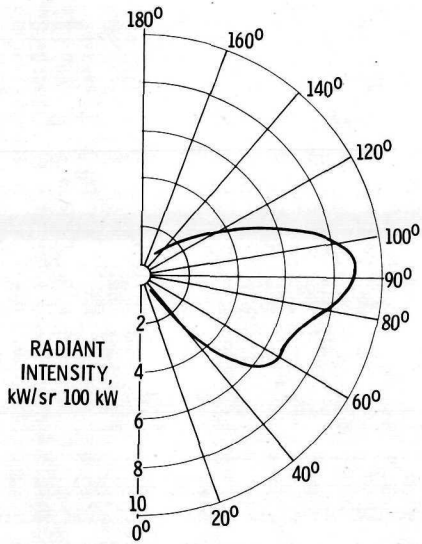

Figure 3. - Radiant intensity of the 380 kW argon arc per 100 kW of input power.

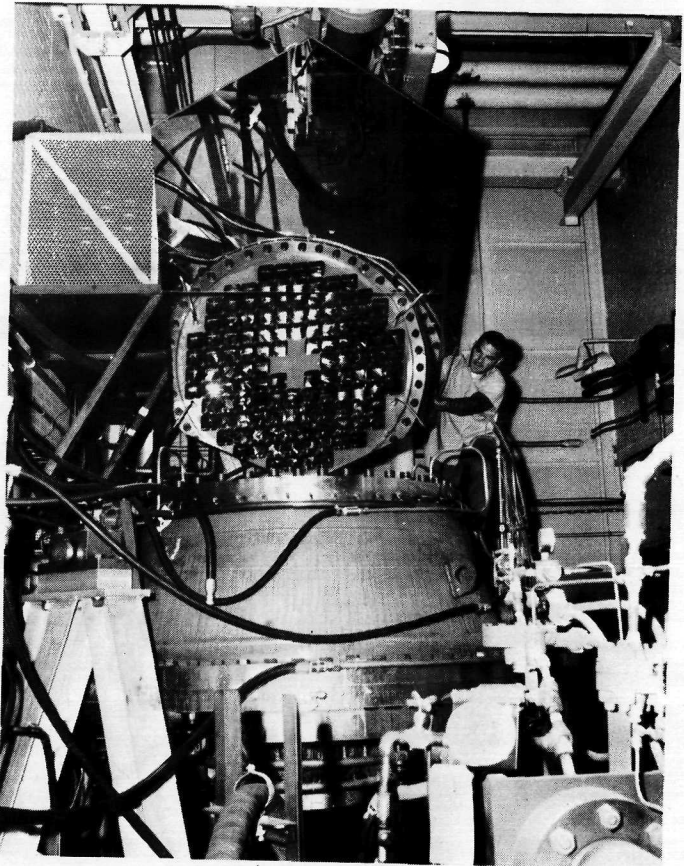

Figure 4. - Arc lamp.

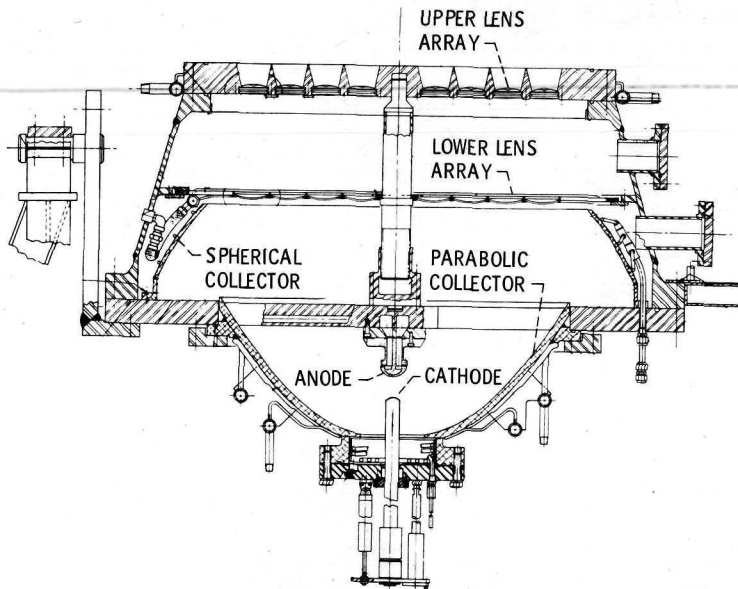

Figure 5. - Sketch of arc lamp.

E-6875.

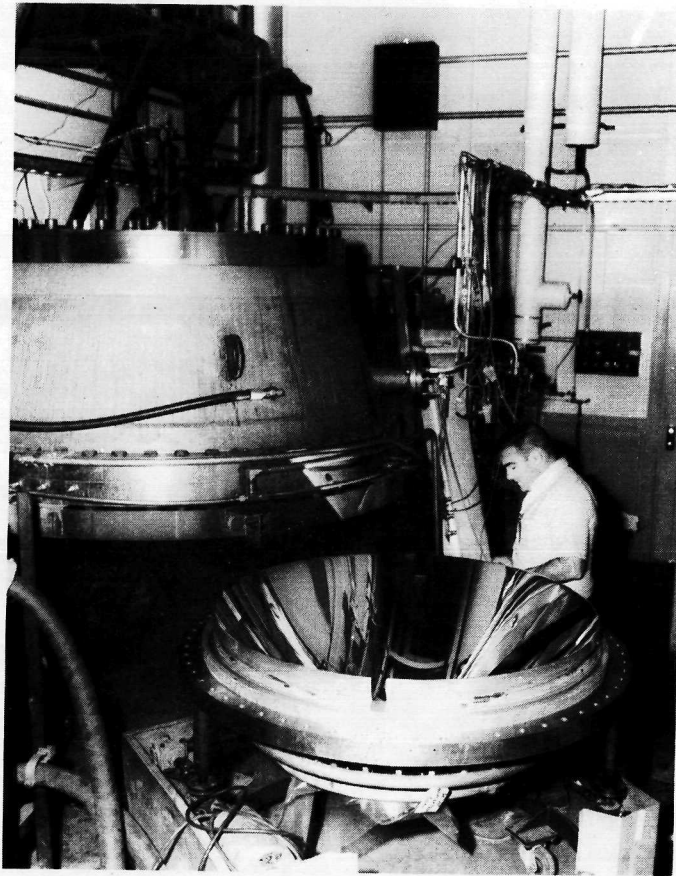

Figure 6. - Parabolic collector.



Figure 7. - Lower lens array.

E-6875

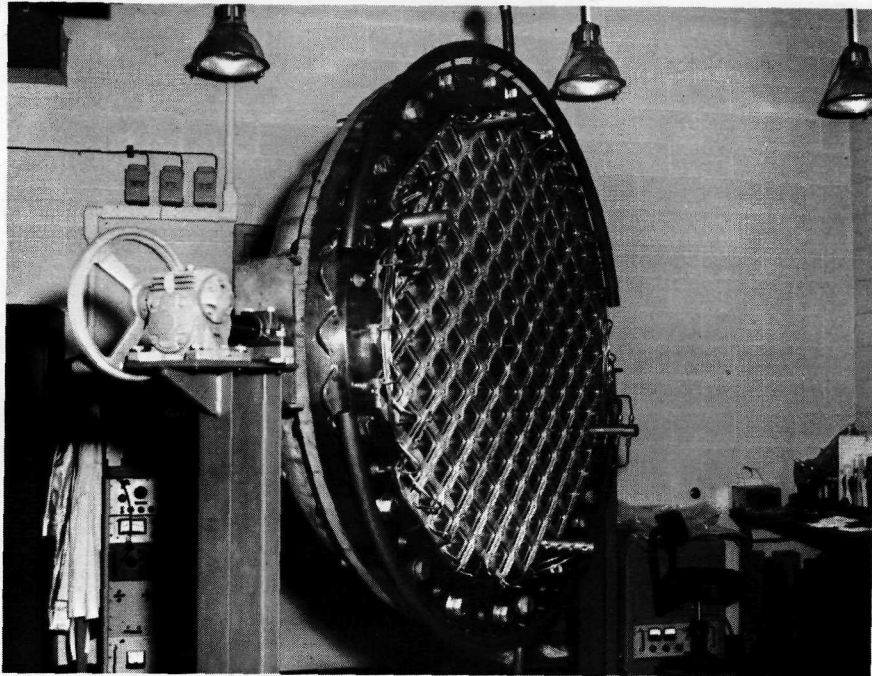
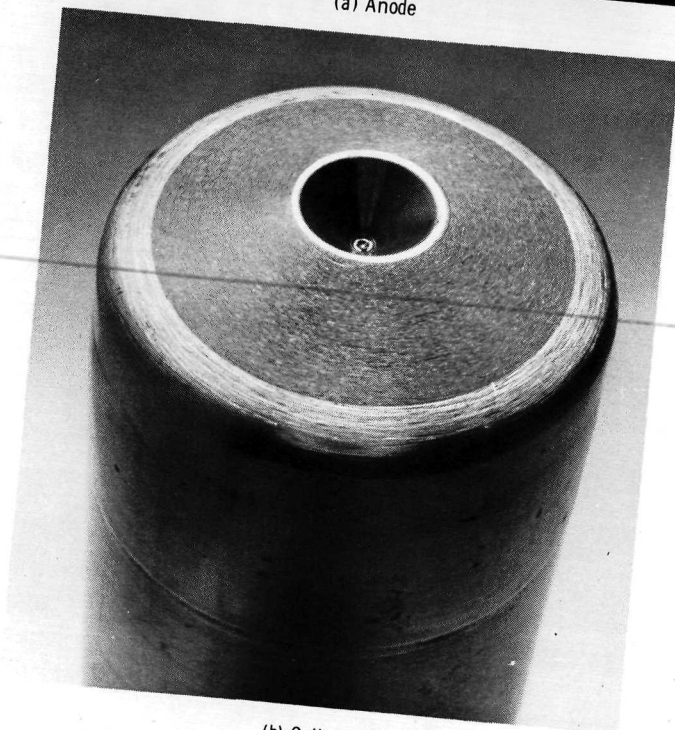

Figure 8. - Upper lens array.

E-6875



(a) Anode



(b) Cathode

Figure 9. - Electrodes.

E-6875

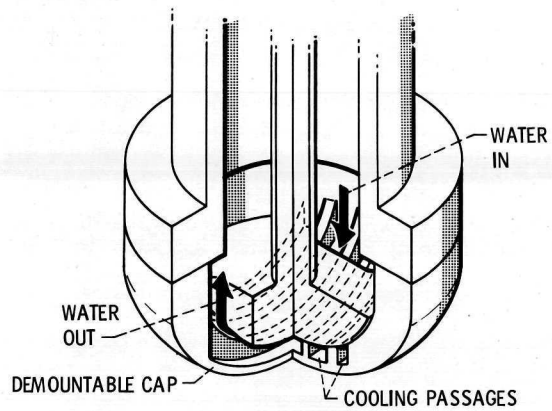

Figure 10. - Sectioned diagram of anode.

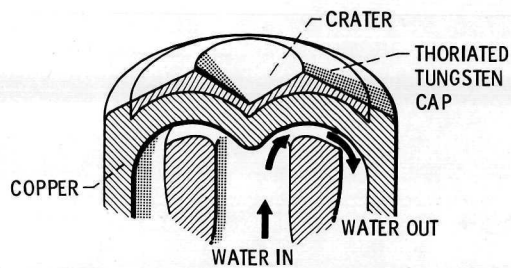

Figure 11. - Sectioned diagram of cathode.

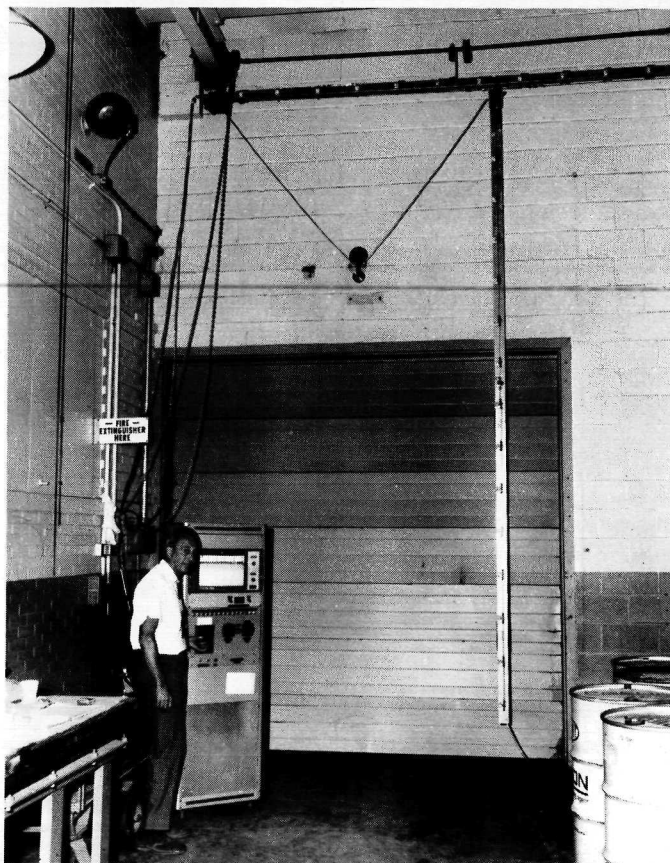

Figure 12. - Radiation scanner.

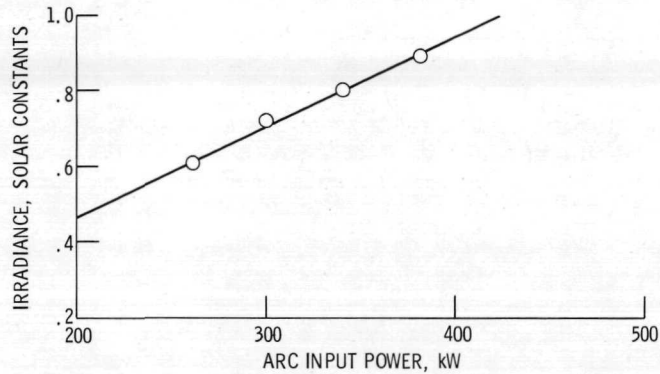

Figure 13. - Typical irradiance in the test volume of the solar simulator. (Does not include the contribution of a spherical collector.)
1 solar constant = 135.3 mW/cm²

WAVELENGTH INTERVAL, μm	ARC LAMP 300 kW	CATHODE VIEW 325 kW (REF. 5)
0.25 - 0.40	11.93	16.98
.40 - .50	12.74	11.93
.50 - .60	9.88	8.96
.60 - .70	7.29	6.78
.70 - .80	12.79	12.30
.80 - .90	10.97	10.85
.90 - 1.0	5.41	4.93
1.00 - 1.4	18.16	15.96
1.4 - 2.7	10.83	11.31

Figure 14. - Spectrum of the arc lamp. (Comparison of the percent of total irradiance in various wavelength intervals for the arc lamp and the cathode view of the arc.)

DESCRIPTION OF PART	PERCENT OF POWER INTO PART	POWER INTO PART, kW
ARGON ARC	100	381
ANODE AND SUPPORTING STRUTS	33.9	129
CATHODE AND CATHODE ASSEMBLY	7.8	29.8
COLLECTOR	7.9	30.0
LOWER LENS HOLDER	6.9	26.3
REGION BETWEEN LENS HOLDER	10.2	38.9
UPPER LENS HOLDER	7.3	27.8
TOTAL POWER RADIATED BY LAMP	26.0	99.0
DIRECTED RADIATION	21	80

Figure 15. - Thermal balance of the arc lamp.