

PREFACE

This report covers the activities of the Midwest Research Institute Biomedical Application Team for the period from 1 August 1970 through 31 October 1971. The objective of the BA Team is to assist in the application of aerospace-generated technology to the solution of biomedical problems. The work is supported and monitored by the NASA Technology Utilization Office, Washington, D. C.

The MRI BA Team is directed by Dr. Thomas Castles, under the management of John E. Stacy, Jr., Manager of Technology Utilization and Assistant to the Vice President, Technical Operations. Other members of the MRI professional staff who contributed to the activities reported herein are Dr. Serge Zilber, C. Kenneth Doll, and Christine M. Guenther.

Approved for:

MIDWEST RESEARCH INSTITUTE



F. V. Morriss
Vice President - Technical Operations

26 November 1971

TABLE OF CONTENTS

	<u>Page</u>
Abstract.	ix
I. Summary of Accomplishments.	1
II. Introduction to Technology Utilization.	13
A. Problem Acceptance.	14
B. Problem Solving	15
III. Midwest Research Institute Biomedical Applications Team Accomplishments During the Report Period.	18
A. Innovations in the Transfer Process	18
B. Technology Transfers Accomplished	21
C. Potential Technology Applications	44
D. Impacts	69
E. Other Accomplishments	94
IV. Statistics of MRI Activity During the Report Period	99
A. Activity Statistics	99
B. Impact Areas.	100
C. Institutions Served	101
Appendix A - Evaluation of Potential Transfers.	103
Appendix B - Evaluation of All Currently Active Problems (October 31, 1971)	111
Appendix C - Benefits of a Working Relationship With Elements of a Patient Care System.	115
Appendix D - Problem Descriptions (By Health Area).	121

List of Figures

<u>Figure</u>	<u>Title</u>	<u>Page</u>
1	NASA-Developed Respiration Monitor.	22
2	Cleft Palate Air Flow Monitor	23

TABLE OF CONTENTS (Continued)

List of Figures (Continued)

<u>Figure</u>	<u>Title</u>	<u>Page</u>
3	Powered Prosthetic Device	25
4	Battery State-of-Charge Indicator (Coulometer) Attached on Left Side of Prosthetic Power Pack.	25
5	Pressure Transducer Calibrator.	27
6	Air Shower for Rodent Quarters.	33
7	Hydro-John as Received.	35
8	Modified Hydro-John	36
9	Flushing Urinal	38
10	Flushing Urinal (Cutaway)	39
11	Isolation Garment With Face Mask.	41
12	Plastic Mask Without Outer Isolation Garment.	42
13	Use of Anti-Fogging Agent	43
14	A Proposed Hospital Management Center	45
15	Tunnel Diode Transducer	47
16	NASA Modified Wright Spirometer	52
17	Respirometer Flowmeter.	53
18	Triaxial Piezoresistive Accelerometer	55
19	Proposed Geographic Display of Medical Data	57
20	Follow-Up to Visit to Methodist Hospital of Indiana, Inc.	70
21	Section in Medical Technological Development Committee, 1970-1971 Report.	74

TABLE OF CONTENTS (Concluded)

List of Figures (Concluded)

<u>Figure</u>	<u>Title</u>	<u>Page</u>
22	Evaluation of Information Transfer at the University of Wisconsin	75
23	Safety Bulletin Evaluation.	76
24	Fiber Optics Document Evaluation.	77
25	Tactile Sensors Literature Evaluation	80
26	Program for the Clean Room Symposium at KSC	82
27	Program for the Clean Room Symposium at San Francisco	84
28	Tulsa TRIBUNE Article on MRI-BA Team.	97

List of Tables

<u>Table</u>	<u>Title</u>	<u>Page</u>
I-A	Potential Transfer Evaluation Format.	104
II-A	Evaluation of Current MRI Potential Transfers, September 1970	105
III-A	Evaluation of Current MRI Potential Transfers, October 1971 .	109
I-B	Evaluation of Current MRI Problems (October 1971)	112

ABSTRACT

Midwest Research Institute has been active in an experimental program of technology transfer supported by NASA Contract No. NASW-1936 for the 1 August 1970 to 31 October 1971 reporting period. The Biomedical Application Team, a multidisciplinary group of scientists and engineers, acts as an information and technology interface. It provides a valuable link between NASA and organizations involved in biomedical research and clinical medicine. The biomedical applications activity was conducted by the following MRI staff:

Dr. Charles Kimball, President, MRI
Dr. F. V. Morriss, Vice President, Technical Operations
Mr. J. E. Stacy, Manager, Technology Utilization
Dr. T. R. Castles, Director, Biomedical Applications Team
Dr. S. Zilber, Senior Biomedical Engineer
Mr. C. K. Doll, Associate Engineer
Miss C. M. Guenther, Research Assistant

The following 19 medical institutions participated in the Biomedical Application Team program during the report period:

Kansas University Medical School
Kansas City, Kansas

University of Minnesota Health Sciences Center
Minneapolis, Minnesota

Missouri University
Columbia, Missouri

University of Wisconsin Medical School
Madison, Wisconsin

Washington University School of Medicine
St. Louis, Missouri

Creighton University College of Medicine
Omaha, Nebraska

Iowa University College of Medicine
Iowa City, Iowa

University of Missouri-Kansas City Dental School
Kansas City, Missouri

University of Nebraska College of Medicine
Omaha, Nebraska

Parsons State Hospital and Training Center
Parsons, Kansas

United Cerebral Palsy Association
Kansas City, Missouri

St. Luke's Hospital
Kansas City, Missouri

Western Missouri Mental Health
Kansas City, Missouri

Milwaukee County General Hospital
Milwaukee, Wisconsin

United Methodist Hospital of Indiana, Inc.
Indianapolis, Indiana

Midwest Research Institute
Kansas City, Missouri

Kansas City Health Department
Kansas City, Missouri

Wayne Miner Health Center
Kansas City, Missouri

Meningomyelocele Association
Kansas City, Missouri

In addition to these institutions, MRI's BA Team has worked with other organizations and individuals active in the medical field including: the American Academy of Family Physicians (formerly the American Academy of General Practice); the Missouri Regional Medical Program; and many individual surgeons across the country with an interest in bacteria control in surgery suites, including many prominent members of the American Academy of Orthopedic Surgeons.

During this reporting period, the BA Team has identified 86 new problems for investigation. It accomplished nine transfers of technology and identified 21 new potential transfers. As of 31 October 1971, 125 active problems had been under investigation.

MRI is particularly indebted to the Technology Utilization Office of NASA Headquarters and to each of the NASA Space Centers for their assistance in the identification and interpretation of space technology.

I. SUMMARY OF ACCOMPLISHMENTS

During this reporting period the MRI BA Team, with the assistance of NASA's Office of Technology Utilization and the NASA Space Centers, put aerospace-generated technology to use in the biomedical and health care delivery fields.

This period was one of experimentation and transition--experimentation: with new ways to seek and evaluate medical problems, ways to establish permanent relationships with medical organizations, and ways to document the application of technology--transition: from an operation that solicited numerous problems in a medical school environment to one that concentrated on a limited number of interactions with those on the front lines of health care delivery.

Some of the accomplishments have involved the application of devices, materials, or procedures including:

- An airflow monitor for children with cleft palates
- A state-of-charge indicator for a powered prosthetic hand
- A calibrator for catheters used in cardiac pressure measurements
- A current limiting circuit for an electroanesthesia generator
- A cross-contamination barrier system for experimental animal quarters
- Techniques for sterilization of prosthetic devices in the operating room
- Use of a Skylab prototype waste management system for handicapped persons
- An anti-fogging agent for surgeons face masks

Other accomplishments have been of a different nature; involving interactions with health care delivery professionals. Most notable are these two:

Symposium on Clean Room Technology in Surgery Suites

As a result of a prior transfer of aerospace technology by MRI's BA Team, considerable information was obtained about "Clean Room Technology" and its application to surgery suites. As the interest in such technology was growing rapidly and there appeared to be many unanswered questions, it was felt that a conference was needed. Such a meeting was planned and held in May at J. F. Kennedy Space Center.

The meeting which was attended by 80 representatives of NASA, industry, and the medical profession including surgeons, was a great success. There have been many spinoff benefits of the meeting including:

- Identification of many problems that lend themselves to aerospace solutions
- One application and one potential application of space technology
- Projected use of a NASA document as a starting point for incorporating microbial considerations into a revision of Federal Standard 209a.
- Publication of one of the papers given at the symposium in the September/October 1971 issue of Contamination Control magazine.
- A summary of the entire meeting is being published in a two part series in Hospital Topics magazine (Vol. 49, Nos. 10 and 11).
- A similar symposium to be held in November in cooperation with Ames Research Center.
- The proceedings of the conference will be given to all attendees of workshops on orthopedic surgery given by the Cleveland Clinic.

The Department of Health Care Technology

In seeking successful mechanisms of technology transfer it was found that intimate professional relationships between BA Team members and medical personnel were needed.

A mature professional with a Ph.D. in biomedical engineering was added to the team and assigned to spend at least a day per week in one local teaching hospital. He was readily accepted by

the medical staff and helped solve several of their problems-- one with aerospace technology and several with data from other sources.

The initial BA Team effort has led to the activation of the Department of Health Care Technology--a self-supporting activity dedicated to bring all sources of technology to bear on problems of the other departments in the hospital. This activity will continue without the need for funding from NASA.

Other accomplishments were involved with the technology of "technology transfer" and in the documentation of applications.

A method of evaluating medical problems was devised that dealt with the attributes of the problem, the technology, the investigator, and the resources required. A general philosophy resulted from the development and application of this evaluation method as discussed in the section entitled: Innovations in the Transfer Process.

A new publication format was developed that allowed disclosure of an application of aerospace technology in a brief, interesting, and professional manner. Two of these new "bulletins" were produced and are included in this section of the report. A third bulletin on the use of MEDATA by a Denver hospital was held in final draft form pending scheduled improvements in the MEDATA program by NASA.

Although the MRI mission was primarily biomedical in nature, the team provided services in support of the total mission of the NASA Technology Utilization Office. As a result of previous experience with NASA management techniques, MRI gave a paper on use of NASA Management Information Centers at the joint ICMA/NASA meeting at Kennedy Space Center, participated in a regional meeting of the same nature in Kansas City, furnished additional data to several city managers interested in such facilities, assisted in the development of a center for an Alcohol Safety Action Project, and provided data to the University of Denver on successful applications of NASA management techniques.

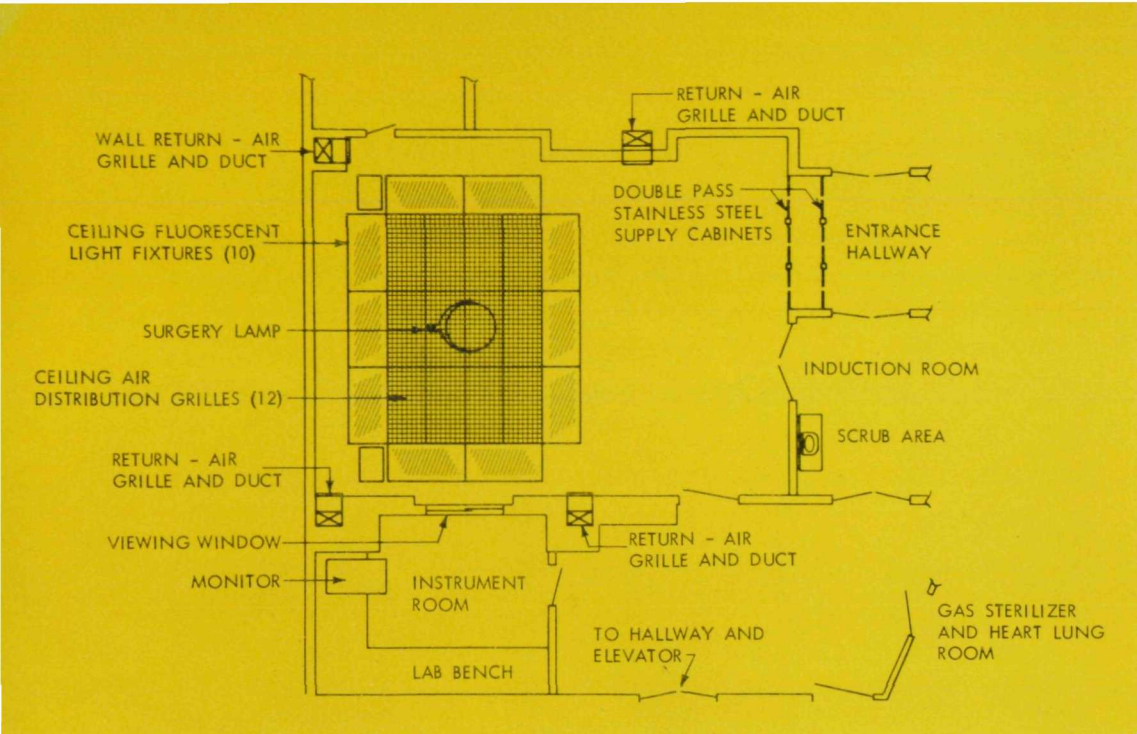

Figure 1—"Floor Plan for Cardiothoracic Surgical Suite, Barnes Hospital. All rooms peripheral to the operating room have a separate ventilation system."

Renovation of the cardiothoracic surgical suite and installation of a laminar flow ventilation system was prompted by bacterial air sampling which showed the consistent presence of *Staphylococcus albus*. Renovation plans drew from the NASA/AEC experience in clean room technology and included consideration of construction materials, traffic flow, and clothing procedures. Multiple documents were utilized to aid in the job description and renovation plans, and specifically for the justification of the expenditure. Those documents specifically used include: descriptions of laminar flow systems,⁴⁻⁶ room layouts,⁷⁻⁹ high-efficiency particulate air (HEPA) filters,¹⁰ ventilation system design¹¹ and bacterial monitoring.¹²⁻¹⁵

Although most clean rooms have 500-600 room changes per hour, the necessity for a class 100 operating room has not been established. Based on the NASA documentation of bacterial clearance versus flow rates and a preliminary report, 100 room changes per hour was chosen as the maximal flow rate. This represented the best compromise between cost and reduction of airborne bacteria.

The current cardiothoracic surgical suite is used only for those patients known to be free of clinical infection. A wide range of patients have been operated upon from the newborn to the very elderly. Approximately 75 percent of all operations are open-heart procedures. The remainder are of a "closed" or palliative nature.

Special precautions in force in the room's operation are the extensive use of Barbac gowns and drapes to reduce lint. Removal of all non-essentials, tables, hampers, stools, and most important, personnel. Monitoring and blood gas analysis personnel are stationed in a separate room which communicates with the operating room by a sliding pass-through Lexan window. Audio communication is used for feedback of the test results. All supply cabinets are filled from behind eliminating unnecessary traffic. No patient bed or linen is permitted in the operating room. All transfers and preparations are conducted in the anesthesia induction room prior to and following the operation.

Bacterial monitoring has been conducted with an Anderson Air Sampler. Air samples are taken at three different periods for 10 min. each, yielding 18 blood agar plates for each operation. Bacterial colonies are counted at 24 and 48 hr. and each colony is subcultured for species identification. Particle counting has been performed with a Coulter counter model 130 which yields printout of four ranges of particles 0.5-1.0 μ , 1.0-5.0 μ , 5.0-10.0 μ , and > 10.0 μ . Bacterial sampling was performed 3½ months prior to renovation and for 6 months since renovation at both 3 ft. from the floor and at the wound edge. Preliminary studies have

shown little change between the pre- and post-renovation bacterial counts at 25 room changes per hour. However, at 100 room changes per hour a significant decrease in airborne bacteria was found. With no activity in the room, the total particle counts range from 116 to 3,790 per cubic foot of air for the particle sizes studied. With activity the total particle counts range from 1,470 to 14,850 per cubic foot of air in contrast to the peripheral rooms where the counts range from 30,000 to 340,000 per cubic foot.

During the 6 months of operation there have been no significant wound or prosthetic material infections. This system has yielded high flow ventilation with superior cleanliness, excellent thermal, humidity and noise characteristics for \$8,000.00 equipment cost and 2,304 labor hours.

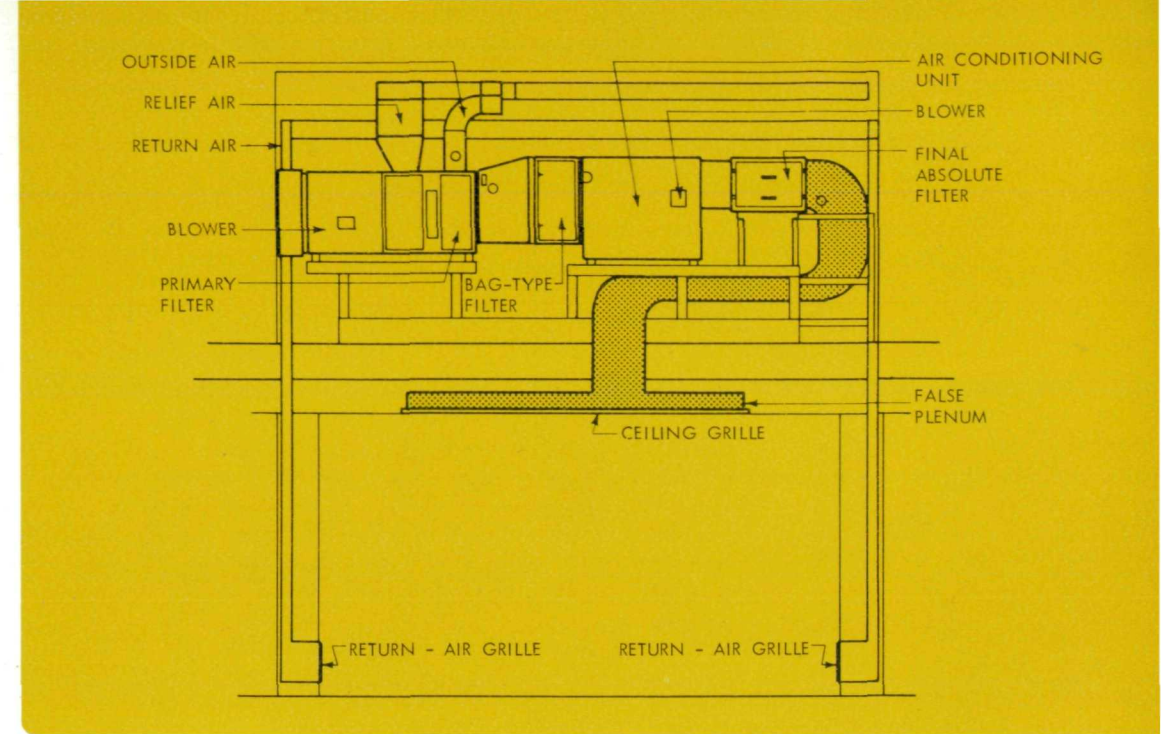
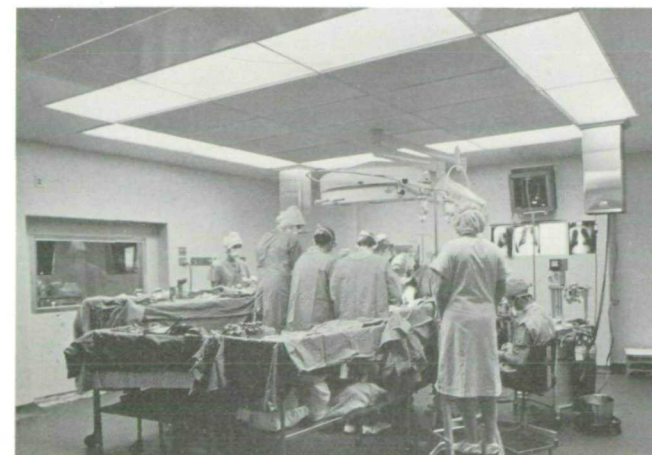

Figure 2—"a Schematic Side View of Ventilation System for the Operating Room. Capacity is 100 room changes per hour."



Clean air distributes through perforated epoxy-coated panels with a maximum linear velocity of 1.27 ft./sec. A service column is in the upper left corner.



"Ceiling grilles cover patient and instrument areas. The monitor room window is on the left."

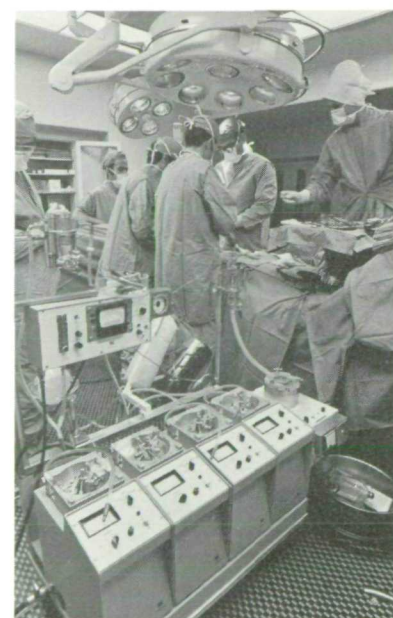

"The heart-lung machine is in readiness for open-heart surgery."



Stainless steel double pass cabinets permit replenishment of supplies through back doors located in the entrance hall.

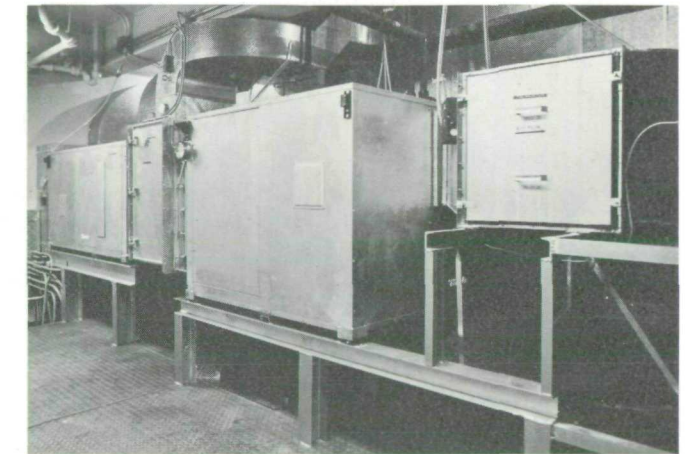

The ventilation system is located in a previous viewing gallery. The 99.97% efficient HEPA filter is on the right.



Open heart operation in surgery suite previous to renovation.

SPECIFICATIONS

General

- The operating room measures 20' x 24'.
- The operating area is continuously flushed with clean, bacteria-free air.
- The plaster walls are coated with a layer of vinyl covered with Teflon.
- All cabinets and storage shelves are stainless steel.
- Three ancillary rooms, ventilated by a separate system, provide room for the necessary instrumentation, induction of anesthesia, scrub and preparation area.

Ventilation System

- The operating room ventilation system is entirely separate from all other systems.
- The system maintains a positive pressure differential between the operating room and the hospital and ancillary rooms of 0.25" water pressure.
- The blower system is a single 7.5 h.p. motor and squirrel-cage fan on the air supply and 7.5 h.p. motor and squirrel-cage fan on air return.
- Blower capacity is approximately 7,300 cfm.
- Blower output is adjustable by changing pulleys to permit a range of 25 to 100 room changes/hour.
- Filtration is accomplished in three stages: 30% efficient 5-micron fiberglass element rough filter; bag-type primary filter, 95% efficient at 3 microns; HEPA final filter, 99.97% efficient at 0.3 microns.
- Heating and cooling coils control air temperature in the mixing chamber.
- A humidifier downstream of the HEPA filter controls the relative humidity.

- The system permits total recirculation, 100% outside air, or any ratio thereof. Make-up is provided by outside air.
- A single distribution plenum delivers air to 12 ceiling grilles in the operating room. The grilles, measuring 2' x 4', comprises a total area of 96 sq. ft.
- Return air exits the room through four wall grilles and return ducts mounted in the walls near the floor. Each of these grilles measures 2' x 2'.

Electrical Characteristics

- Vapor-tight service is provided throughout the operating room.
- Conductive tile floor with electrical ground maintains limits on the resistance between electrical ground and any location on the floor within 75,000 to 400,000 OHMS. per city code. Less than 1 millivolt potential exists between any two points in the wiring ground system.
- Fluorescent light fixtures are mounted flush in ceiling around the air inlet grille.

Room Operating Conditions

- Blower output is set for 100 room changes/hour.
- Air velocity is approximately 69 fpm. or 1.15 ft./sec.
- Temperature and relative humidity are 70° F. and 55%, respectively.
- Air mixture is 80%, recirculated, 20% outside and make-up air.
- Noise level measured at 100 room changes/hour was 53 db with the room empty.

BIBLIOGRAPHY

1. Baldwin, M., and D. G. Fox, "Laminar Flow for the Neurosurgical Operating Room," *J. Neurosurg.*, 6, 660-665 (1968).
2. Chamley, J. A., "A Clean Air Operating Enclosure," *Brit. J. Surg.*, 51, 202-205 (1964).
3. Yates, G., and G. P. Bodey, "Laminar Air for Cancer Patients," *Contamination Control J.* (Oct. 1968).
4. Coriell, L. L., Wm. S. Blakemose and G. J. McGarrity, "Medical Applications of Dust-Free Rooms. II. Elimination of Airborne Bacteria from an Operating Theater," *J. Am. Med. Assn.*, 203, 134-142 (1968).
5. "Contamination Control Principles," by Sandia Corporation, Albuquerque, New Mexico, NASA SP-5045, N68-10384 (1967).°
6. Lindell, C. F., W. J. Whitfield, and D. M. Garst, "Design Requirements for Laminar Air Flow Clean Rooms and Devices," by Sandia Corporation, Albuquerque, New Mexico, for NASA, N69-34607 (1969).°
7. Powers, E. M., "Microbial Profile of Laminar Flow Clean Rooms," NASA Technical Memorandum, X-55320, Goddard Space Flight Center, Greenbelt, Maryland, N66-11212 (1966).°
8. Beakley, J. W., W. J. Whitfield, and J. C. Mashburn, "Evaluation of the Efficiency of a Class 100 Laminar-Flow Clean Room for Viable Contamination Cleanup," NASA Contract Report CR-78342, by Sandia Corporation, Albuquerque, New Mexico, N66-37585 (1966).°
9. Fox, D. G., "Study of the Application of Laminar Flow Ventilation to Operating Rooms," U.S. Public Health Service Monograph No. 78 (1969).
10. Klamerus, L. J., and M. I. Tillery, "A Study of HEPA Filter Efficiency in Sub-micron Particle Range," given at AEC/NASA Symposium on Contamination Control, Albuquerque, New Mexico, N68-29343 (1967).°
11. Useller, J. W., "Clean Room Technology," Lewis Research Center, Cleveland, Ohio, NASA SP-5074, N69-33775 (1969).°
12. Michaelsen, G. S., O. R. Ruschmeyer, and D. Vesely, "The Bacteriology of Clean Rooms," NASA Contract Report 79114 by School of Public Health, under Grant No. NSG-643, University of Minnesota, Minneapolis, N66-39919 (1966).°
13. Michaelsen, G. S., O. R. Ruschmeyer, and D. Vesly, "The Bacteriology of Clean Rooms," NASA Contract Report 890, by School of Public Health, University of Minnesota, Minneapolis, Grant No. NSG-643, N67-38824 (1967).°
14. Mathews, J. B., "Sterilization Assembly Development Laboratory Monitoring Plan," NASA Contract Report 94341, by Avco Corporation, Lowell, Mass., N68-22519 (1968).°
15. "Contamination Control Handbook," by Sandia Corporation, Albuquerque, New Mexico, for NASA, N70-13566 (1969).°

°Copies of these documents are available to the public from the National Technical Information Service, Springfield, Virginia 22151, at a standard price of \$3.00. These documents should be identified by their accession number (e.g., N70-12345), which appears in the bibliography.

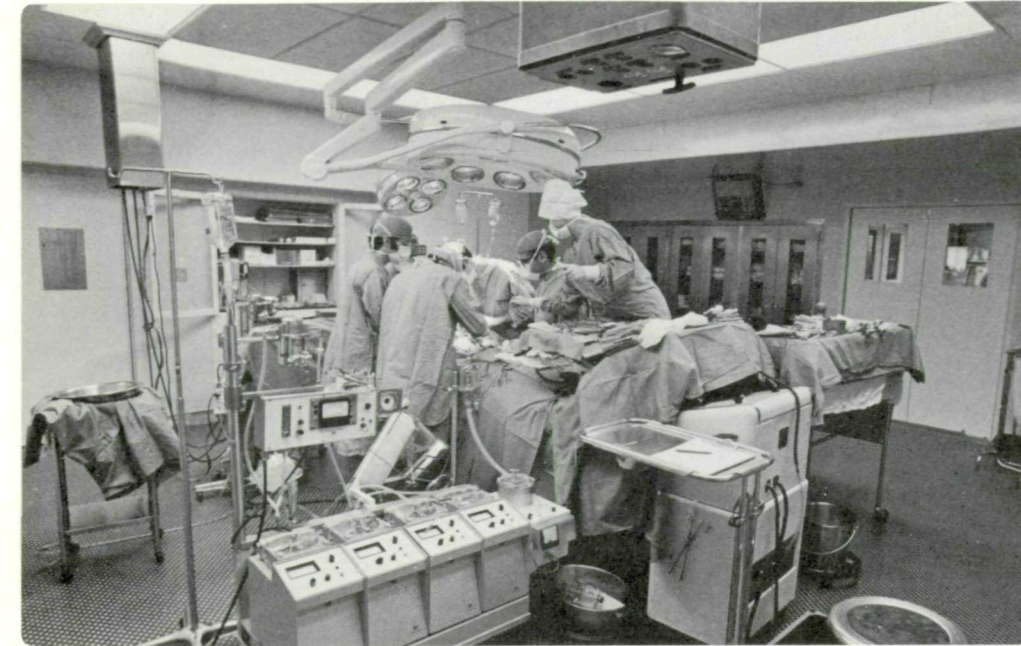

A look at BARNES HOSPITAL
use of NASA/AEC
Clean Room Technology
for a cardiothoracic
operating suite

March 1971

BIOMEDICAL
APPLICATION
BULLETIN

The past decade has seen a rapid improvement in the care and survival rates of patients with heretofore fatal illnesses. The advent of open heart surgery, organ transplants, joint replacements and cancer chemotherapy has salvaged many lives but provided many medical problems which required new answers. Foremost among these problems has been infection in the highly susceptible patient. Infections initiating in the operating room can occur from a breakdown of sterile technique, seeding from a member of the team, the patient, or through airborne bacteria. Careful supervision, vigilance, and precautions can greatly reduce the infection rate from all sources except, until recently, the air.

Modern air handling technology, developed by the "National Aeronautics and Space Administration" (NASA) and the "Atomic Energy Commission" (AEC) has now been applied to the medical field to lower contamination by airborne bacteria. Clean rooms, developed to provide a near particle free environment, were found to reduce the concentration of bacteria from 1,000 to 5 microorganisms per 100 cubic feet of air by eliminating 99.97% of particles greater than 0.3 microns in size.¹ Such installations have been reported to lower clinical infection rates.^{2,3}

The Division of Cardiothoracic Surgery of Washington University Medical School and the Barnes and Allied Hospitals in St. Louis, Missouri, has applied modern clean room technology to a 42-year-old operating room. The renovation of this operating room was headed by Dr. Richard E. Clark, a Cardiothoracic surgeon with an engineering background and Mr. Kurt Bemberg, Chief engineer of the Barnes Hospital. Several commercial types of clean rooms were considered before the aid of NASA was sought through MRI's Biomedical Applications Team. Assisted by NASA documents on clean room technology, a ventilation system for a cardiothoracic surgical suite was designed and constructed. The renovation was completed in six weeks.

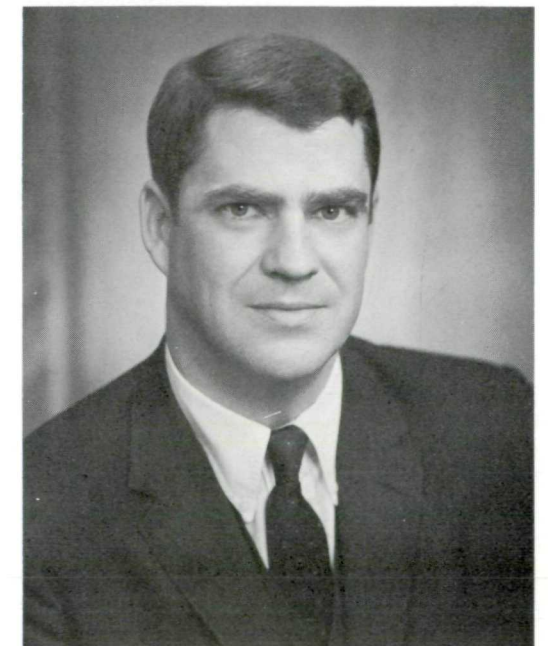

Dr. Richard E. Clark

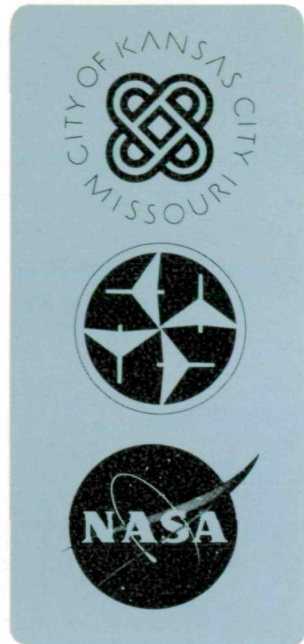
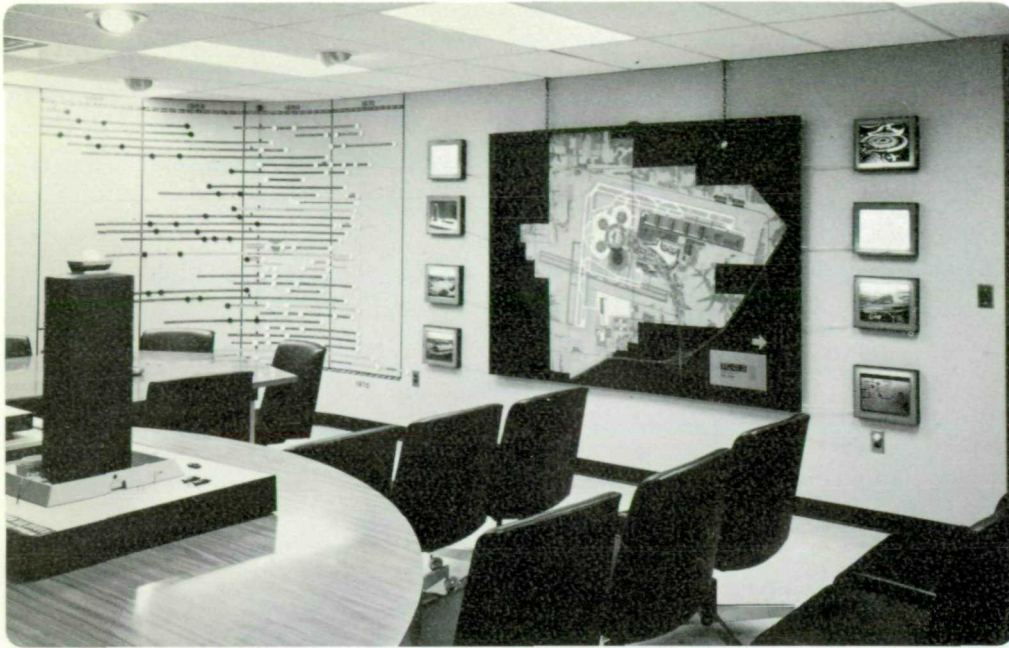

**From KSC to KCI:
Kennedy Space Center-type control room
is focal point for development of Kansas City
International Airport**

October 1971

TECHNOLOGY APPLICATION BULLETIN

“On the eighth floor of the City Hall (Kansas City, Missouri) is a unique facility—the KCI Management Information Center. It is unique because its closest counterpart is not in another city hall but at John F. Kennedy Space Center where it’s used by the Apollo Program Manager.” These words, originally printed in the *Kansas Citian* magazine, introduce an effective application of NASA technology by a unit of local government.

KCI is the abbreviation for Kansas City International Airport—a new and imaginative project that will represent about a \$200,000,000 city, federal, and private investment when it opens in 1972.

When the development of this airport reached the construction phase, city officials realized that special steps had to be taken in order to control such a massive project. A KCI management team was organized, and a separate “on-site” construction management group was established. Computer-assisted systems of schedule and cost control were implemented.

Steps were taken to improve communication, which was viewed as a key to successful management. One of these steps was creation of the KCI Management Information Center as a combination meeting and briefing room, where team members could “think airport” surrounded by data conducive to good decision-making. Regularly scheduled meetings have been conducted here to insure that problems are resolved quickly, and every team member’s knowledge is up-to-date.

“We obtained the idea of a fully-equipped briefing room from NASA,” says a recent city story on KCI development. “The key idea when we want to exchange information and ideas is to bring the airport to City Hall rather than vice versa.”

Except for the names and titles of the participants and some of the terminology, a typical KCI meeting could well be mistaken for one taking place at John F. Kennedy Space Center.

BENEFITS OF A MANAGEMENT CENTER:

- It is the catalyst for a total project management approach which includes organization, management systems, and reporting methods.
- It is a convenient repository for easily referenced data on the project—goals, responsibility for tasks, and progress.
- It stimulates a real team management spirit with free exchange of data about plans, status and problems.
- It is a “programmed” conference room that makes periodic project review meetings both productive and well attended.
- It allows decisions to be based on consistent and current information.
- It facilitates briefing of VIP’s, civic groups and new team members.
- It offers a convenient source of data and graphics for use by the media to inform the public.
- It provides visible evidence of good management practices.

FEATURES AND DISPLAYS

The unusual design of the KCI Management Information Center was partially dictated by the original construction of the room, which included a free-standing structural column. The center projection-booth peninsula was used to hide the column and divide the room into two zones—one for meetings, and the other for walk-through briefings.

Flexibility is the key word. Charts which are updated frequently are made of magnetic markers on the vinyl-covered metal walls. Maps are posted without backing to allow use of magnetic markers to designate present and future features on the airport site. Displays can be revised easily and surfaces could be stripped of all airport displays in a matter of minutes whenever the room is to be converted to another purpose. Cork panelled areas are used to post temporary data, and a display shelf is provided for models of new or proposed airport structures.

In addition to the displays, audio-visual equipment is used to bring progress views and architectural renderings to the meetings on a rear screen. The conference leader has remote-control capability in a console-podium which can be used at table-side or in a standing position. A random-access 35-mm slide projector and a 16-mm movie projector can be controlled from the console, along with room accent spots, blackboard lights, and a tape recorder. A portable video tape player and TV monitor are stored in the projection booth and moved in when needed.

The Center, which cost \$16,000 to construct, is in essence a programmed conference room with all of the displays and features necessary to inform visitors, brief officials and facilitate meetings of the development team.

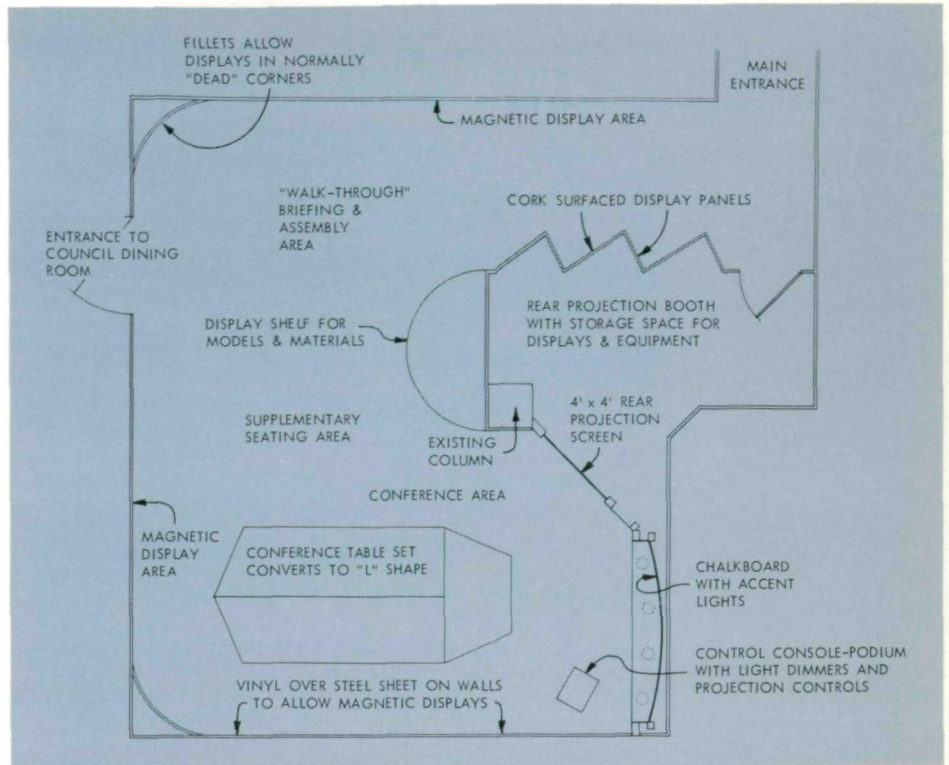

Floor plan of Kansas City International Airport Management Information Center, 8th floor, City Hall, Kansas City, Missouri. Overall dimensions are 28 x 30 feet.

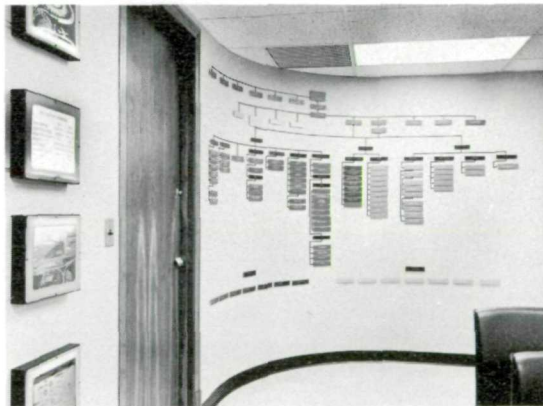

Vinyl-covered metal fillets provide more advantageous use of corner space as illustrated by this magnetic display of the KCI project organization chart.



The speaker can control room lighting and audio-visual equipment from control console-podium as selected discussion topics appear on rear screen.



A variety of surfaces, such as the cork panels on the projection booth, permit greater flexibility in displaying project information.



The mayor and city council are represented at the KCI management review meetings by their finance and audit committee. From left: Richard C. Tolbert, member; Leon Brownfield, member; Sal A. Capra, chairman; and Richard L. Berkley, vice chairman.



Key participants in the biweekly KCI management review meetings are; from left: John Taylor, City Manager; Frank Pittenger, Director of Aviation; Myron Calkins, Director of Public Works; and John Urie, Director of Finance (back to camera).



Prior to the biweekly management review meeting, Joe Howard, KCI Development Director, previews the latest video tape progress report with his staff in their field office.

THE USE OF THE CENTER

The KCI Management Information Center is constantly in use for its original purpose and as a convenient conference room. Its KCI airport uses range from the scheduled meetings of the KCI Management Team to periodic briefings of the Mayor and the full City Council.

A typical project review meeting is convened every two weeks during the peak of airport activity by Sal A. Capra, Chairman of the Finance and Audit Committee of the City Council. This committee along with John Taylor, City Manager; Frank Pittenger, Director of Aviation; Myron Calkins, Director of Public Works; and John Urie, Director of Finance, first views a video tape report on airport construction progress presented by Joe Howard, KCI Development Director. A computer printout of the latest airport financial status and cash flow requirements is then introduced by Midwest Research Institute, management consultants to the City.

These two presentations and the Master Development Schedule on the wall form the primary basis for a discussion of airport progress and status. Decisions are made to solve specific problems or to improve procedures, such as the processing of contract change orders. Information is obtained for referral to the Mayor and full City Council when their official actions are required.

This approach helps insure that oversights are minimized, that each member of the management team can carry out his duties without conflict or undue impediment, and that key decisions are based on accurate and timely knowledge of the overall project. The KCI example proves that a normally functional organization such as a city can adopt NASA mission-oriented techniques to reach their own goal "within this decade."

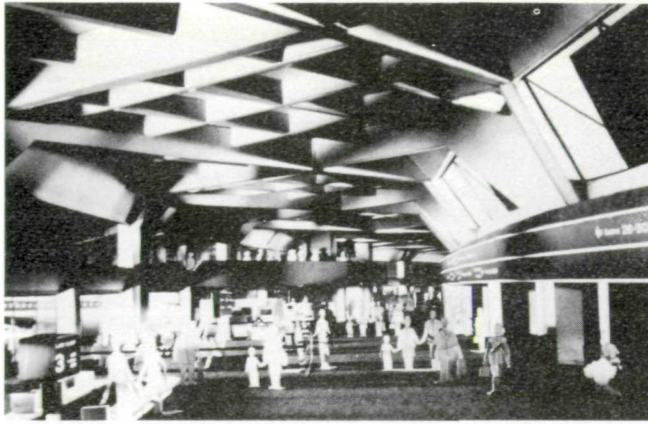

Architect's model showing interior of one of three KCI terminal buildings. Passengers are dropped off or park right at their gate.



Recent aerial view of construction at KCI illustrates the three terminals with exterior aprons and central parking. The entrance road encircles the Control Tower and Airport Operations and Management Building.

ABOUT THE PROJECT

Kansas City International Airport is scheduled to open its gates in 1972.

KCI is an airport of substantial size covering more than 5,000 acres with two initial runways about 10,000 feet long. It will have enough electric power for a city of 20,000, and enough concrete to build a four-lane highway 150 miles long. The three passenger terminals are large partial doughnut-shaped structures two stories high, 2,300 feet long, and only 65 feet wide. The "hole" of each doughnut will provide parking for up to 900 cars. This design, called the "Gate Arrival" concept, will accommodate two million departing passengers during the first year of operation, yet most of them will not have to walk over 300 feet from their car to their plane.

In addition to the construction of general public facilities, the TWA overhaul base, which has been on the site for many years, is being dramatically expanded to service 747 jumbo-jet aircraft. Substantial new air cargo facilities will also help keep Kansas City expanding as an air, rail, and truck distribution center.

GUIDELINES FOR DEVELOPMENT OF A MANAGEMENT INFORMATION CENTER

Centers of this nature can be developed for many purposes: the control of capital improvement projects; management of large city-federal programs such as model cities, alcohol safety action projects, or criminal justice system improvements; or any priority mission of government or industry. The "management of change" is the general goal for use of such a facility.

Regardless of the objective, certain guidelines for development of Management Information Centers should be considered:

1. Decide on the mission for such a facility. If it is to cover several projects, it should have more convertible display surfaces, such as sliding panels.
2. Don't forget the facility is just a focal point for decision makers. Information systems and organizations must often be revised to provide the data essential to support the room. Meetings must be regularly scheduled.
3. Conveniently locate it for the busiest users, but slightly off the beaten path for privacy—no telephones to disrupt meetings.
4. Size according to average number of meeting participants, but allow enough space for other attendees.
5. Furnishings can be plain, but must be functional. If attendees are to view screens and displays on various walls, swivel and tilt chairs are needed.
6. Supplementary room lighting, such as accent spotlights for display, is generally needed. Room-light dimming and zone control over accent lights are beneficial. Controls should be convenient to the speaker.
7. Contact several local sources for ideas on display surfaces, magnetic materials, and audio-visual equipment. Tailor the design to meet the unique needs of your facility and your mission.
8. Consider the cost and convenience of maintaining any displays or audio-visual methods as part of your selection criteria. Don't overlook the 8½ in. × 11 in. transparency with an overhead projector as a quick means of projecting normal reports.
9. If slides and films are to be part of the normal communication capability of the room, the rear screen is a real asset, as it keeps noise and heat of equipment out of the room and allows unobstructed view in only slightly diminished room light. Remote-control capability for such equipment by the speaker is generally required. Multiple screens are sometimes used for more complex and dramatic presentations.
10. In addition to classical audio-visual equipment, consider the merit of video tape to bring the latest status or problem back from the field. A computer terminal is also a potential element of such a room if your organization has a computer data bank and telecommunication capability.
11. Consider security control for sensitive information and equipment. A lockable rear projection room is often adequate.

II. INTRODUCTION TO TECHNOLOGY UTILIZATION

In its broadest sense, "technology" can be considered to be technical information. It was the abundance of technology in 1948 that made NASA possible. What NASA achieved with the technology available to them and the voluminous new technology they created, is now a matter of history.

Those forces responsible for the formation of NASA, foresaw the effect it would have on the technological community and provided in its charter for the dissemination of generated technology to the public. In the 1950's, the major mode for transferring NASA technology was through the commercial sources. Most of these sources were under contract to NASA to develop aerospace technology. Thus, any NASA applications which obviously met other needs were immediately marketed. This is still one of the best and fastest ways to disseminate technology. However, it is also one of the most restricted. Restricted, because it relies on relatively few individuals in certain industrial segments of our population to identify problems and applicable technology. NASA recognized this limitation in 1958 and organized an effort to find ways to achieve a more general dissemination and use of its technology.

The first organized technology utilization effort was to translate NASA findings into forms that could directly benefit industry with a view to broadening the range of applications of these ideas and reducing the time lag to their practical use. This approach led to several significant observations:

1. Nonaerospace industry had very little knowledge of available space technology.
2. The information explosion was rendering traditional channels for the technology dissemination obsolete.
3. Besides the "push" from NASA of their technology into the public mainstream, a "pull" by the user was needed.

From this background NASA launched an all out effort to enhance the utilization of generated aerospace technology. To date, NASA has cataloged via computer more than 750,000 technical documents which increase by approximately 75,000 documents/year. To manage the storage and retrieval process they established regional dissemination centers (RDC's). The primary function of these centers is to make past and current NASA technology available upon request.

Interdisciplinary teams of scientists were also formed to interface the communication gap between the developers and users of technology. Of special interest have been efforts to bridge the gap between NASA's physical scientists and medicine. Teams for this purpose are known as Biomedical Application Teams. Each team consists of a small group of biological and physical scientists who are imaginative, resourceful, and communicate fluently across interdisciplinary lines. Each team is equipped with firsthand knowledge of areas of active research at NASA and contractor facilities, is familiar with NASA's computer-indexed collection of technical information, and is adept at designing search strategies which optimize information retrieval. The teams thus represent a human connection between NASA, its research centers and contractors, and the biological and medical communities. They also provide an experimental framework by which the transfer process can be analyzed.

Whereas the general function of each Biomedical Application Team is to interface between NASA and medicine and/or biology, the mode of interfacing is strictly a function of the situation. For example, a medical researcher may only need information from NASA, while a medical practitioner may need help in experimental design, searching, interpretation of aerospace technology and assistance in applying for funds to accomplish his goals. It is the team's responsibility to do whatever is necessary to facilitate the use of applicable NASA technology, short of performing the actual use operations for the potential user. The "by words" for these teams are "innovation and dynamic opportunism."

NASA's Office of Technology Utilization had four Biomedical Application Teams in operation at the end of this report period: at Midwest Research Institute, Kansas City, Missouri; at Research Triangle Institute, Durham, North Carolina; at Southwest Research Institute, San Antonio, Texas; and at Stanford University Medical Center, Palo Alto, California.

A. Problem Acceptance

Biomedical Application Teams will accept problems that are:

Biomedical

These problems may range from hospital management to biomedical instrumentation, and from technical research to clinical practice. As long as their solution directly benefits the biomedical community, they are considered biomedical problems.

Relevant to Aerospace Technology

The probable existence of an aerospace solution for a specific problem is difficult to predict. Therefore, most problems are considered to have potential solutions in aerospace technology. A few extreme cases can be ruled out. For example, if a drug manufacturer was looking for new methods to mold aspirin there may be an aerospace solution. Conversely, if a drug manufacturer wanted a new drug to replace aspirin there would be little use to search aerospace technology.

Complementary to Teams Capability

Each Biomedical Application Team is interdisciplinary, but with a limited number of areas of expertise. Problems that are biomedical and relevant to aerospace technology, but not within a team's area of expertise, are referred to another team with the appropriate capabilities. If none of the teams have the necessary capability, outside persons will be asked to review the problem.

B. Problem Solving

The complete problem solving procedure consists of four distinct steps: Define, Search, Evaluate and Translate, and Transfer. The number of steps through which a problem goes depends upon the recognition of NASA technology which can provide a potential solution(s).

1. Problem definition: Each problem must be clearly and concisely stated in terms which communicate the same understanding to persons in the physical and biological sciences. This is the most important step in technology utilization and requires several ingredients for success:

a. Rapport between the BA Team and the Problem Originator: There must be mutual respect and trust between the BA Team and the problem originator so that a complete exchange of past experience, ideas, and objections can occur.

b. Close contact between the BA Team and problem: Qualified BA Team members carefully work through the problem with the problem originator and when possible gain physical experience with it.

c. Innovation on the part of both BA Team and problem originator: Often the problem as originally understood by both the BA Team and problem originator becomes a different problem or is found to be a

complex of problems. Both the BA Team and the problem originator must remain open-minded and innovative in order to dig out the primary problem(s).

2. Technology search: There are two major channels through which NASA technology can be sought: NASA archives and NASA space centers. The NASA archives are searched both manually and via computer. Manual searches are performed to provide key aerospace terminology for computer searches and to make a few selected articles immediately available to the problem originator.

One of six Regional Dissemination Centers can be used to perform a complete search of NASA's data banks. These RDC's are:

- ARAC Aerospace Research Applications Center (Bloomington, Indiana)
- WESRAC Western Research Application Center (Los Angeles, California)
- NCSTRC North Carolina Science and Technology Research (Research Triangle Center Park, North Carolina)
- NERAC New England Research Application Center (Storrs, Connecticut)
- TAC Technology Application Center (Albuquerque, New Mexico)
- KASC Knowledge Available Systems Center (Pittsburg, Pennsylvania)

New technology is being developed for NASA daily by universities, research institutes, and private enterprises throughout the United States. Most of it is developed in conjunction with or under contract to one of NASA's space centers. These centers include:

- Ames Research Center (Moffett Field, California)
- Flight Research Center (Edwards, California)
- Goddard Space Flight Center (Greenbelt, Maryland)
- John F. Kennedy Space Center (Kennedy Space Center, Florida)
- Langley Research Center (Hampton, Virginia)
- Lewis Research Center (Cleveland, Ohio)
- Manned Spacecraft Center (Houston, Texas)
- George C. Marshall Space Flight Center (Huntsville, Alabama)

Each center has a technology utilization office that keeps informed on center activities so that problems can be directed to the appropriate experts. By submitting problems to the centers, current technology becomes available to the problem originator as well as expert consulting. Whenever appropriate, the BA Team encourages direct communication between NASA space center personnel and the problem originator.

3. Technology evaluation and translation: All pertinent technology gained from the search is given to the problem originator for his evaluation. The BA Team also evaluates the technology, then meets with the problem originator to discuss its applicability. Applicable technology is then evaluated in more depth with the intent of testing its applicability to the problem. Results of this evaluation may range from a few simple suggestions, to the development of an experimental design necessary for the adaptation of the technology to the problem.

4. Transfer: The ultimate aim of the Biomedical Application Team is the application (or transfer) of the technology to solve a problem. The successful completion of this step relies primarily upon the investigator. If the problem is well-defined, the application feasible, and intent to utilize this technology sincere, then the transfer process will complete itself. The BA Team can greatly influence the first two requirements, by providing the problem originator with multidisciplinary insight, helping him prepare a well planned approach, and guiding him toward potential market places. The last requirement is solely dependent upon the problem originator.

III. MIDWEST RESEARCH INSTITUTE BIOMEDICAL APPLICATIONS
TEAM ACCOMPLISHMENTS DURING THE REPORT PERIOD

A. Innovations in the Transfer Process

1. BA Team staffing and organization: The initial change in the BA Team was to make it more interdisciplinary with the addition of senior medical, biomedical engineering, and management experience. This gave the team more versatility and better access to the full range of NASA technology. Next, the BA Team was removed from all divisional restraints and made directly responsive to top MRI management, who maintain daily contact and conduct formal monthly reviews. This allowed the team more latitude in the pursuit of means to close transfers and facilitated greater use of MRI's total expertise.

2. Program control and intra-team communications: A room was equipped with display panels so that problem status could be monitored and updated. This facility was used for weekly BA Team meetings.

The initial use of this room was to critically review all potential transfers with the goal of identifying the closure action required to complete them. The results of this initial review are contained in Appendix A in order to illustrate the technique, as well as evaluation of the currently active potential transfers as of 31 October 1971.

Next, the review technique for potential transfers was modified to make it applicable to the continuous evaluation of active problems. Appendix B contains the results of the application of this review technique to all problems active as of 31 October 1971.

In addition to continuous problem evaluation, the facility was used for planning and scheduling team activities. It also promoted the exchange of experience and ideas, while preventing duplication of efforts.

3. Working relationships with elements of the medical community: The review of active problems revealed that their solutions fall into two categories:

a. Those where the solution would contribute to an end result which is not yet accepted by the medical community, or

b. Those whose solution would improve the means to achieve an already accepted result.

The fact that most of our problems at the beginning of this reporting period fell into the first category was attributed to the sources of the problems, namely, basic medical research. At best, this type of problem leads to "transfers" of less immediate utility. This problem has also been recognized

by representatives of the Health Care Technology Division of the National Center for Health Services Research of HEW, who have been contacting National Medical Organizations in a search for applications of HEW-generated technology.

To remedy this situation, we initiated efforts to obtain problems whose results were accepted. The primary source of such problems was viewed as those elements of the medical community directly involved in patient care.

Instead of soliciting problems from the entire spectrum of the patient care system, we aimed at one of the primary goals of the TU program-- to establish a working relationship with an element of the patient care system. Relationships are only being sought with groups having reputations as "doers" and a desire to innovate. The first such group chosen was a team of cardiologists at St. Luke's Hospital in Kansas City who had previous experience in the use of bioengineering. We have succeeded in becoming their trusted source for bioengineering and new technology. The relationship has resulted in at least one transfer and promises to yield many more. More recently, MRI BA Team efforts led to the formation of a Department of Health Care Technology at St. Luke's Hospital, which is totally self-supporting. This arrangement promises to provide several clinical problems and the vehicle through which technology can be transferred. The benefits of our approach are summed up in a letter from one of the cardiologists contained in Appendix C.

4. Better interaction with NASA space centers: During the contract period, we began efforts to effectively utilize the resources of the space centers to achieve technology transfer. Initially, visits were made to selected space centers in order to determine the status of their current technology and to establish lines of communication within each center. NASA space facilities visited include Kennedy Space Center (KSC), Ames Research Center (ARC), and Manned Spacecraft Center (MSC). On our visit to MSC, we were accompanied by medical and administrative personnel from a local hospital. This trip was intended to determine whether on-site experience would enhance the recognition of space technology applicable to medicine. One potential transfer resulted from this trip and NASA gained two more supporters who appreciate the merits of the TU effort and the importance of innovation for its success.

We made it a policy to increase our telephone contacts with TU officers and individual researchers at the NASA centers. These contacts were made for three basic reasons:

- Help identify current technology that might be applicable to our problems,
- Clarify status and/or details of technology reported by their center,
- Activate relationships between our problem originators and NASA personnel working in related areas.

Abstracts of current research projects at NASA centers were furnished to MRI by TUD. This information allowed us to correlate active problems with current NASA activity. The abstracts included names of personnel directing each project which allowed us to arrange a collective meeting with 11 NASA scientists.

The meeting resulted in an efficient and effective discussion of many medical problems, 34 of which were found to be directly related to current projects at Ames. As a result of this meeting, two joint proposals between NASA scientists and medical investigators were submitted for funding.

Our initial experience with this method and its apparent effectiveness would appear to allow consideration of it as a complement or alternative to the submission of problem statements to the NASA centers.

5. Developed a new publication to document applications of space technology: In order to comply with the requirements for professional documentation set forth by TUD, we reviewed our transfer follow-up and documentation practices. We found that the following attributes were needed in a transfer document:

- High visibility to appeal to a wide variety of audiences
- Concise description of the application of the technology and its contribution to the particular problem area.
- Clear definition of NASA's role in the solution
- A useful base for both diffusion and improvement of the technical application by others
- Recognition to all those involved in the transfer, especially the problem originator

These documents are shown in Section I. One issue describes NASA's contribution to a clean operating suite at Washington University in St. Louis. The second, describes NASA's contribution to the management of construction of the new International Airport in Kansas City. This format achieves the aforementioned goals for professional documentation of technology transfers.

B. Technology Transfers Accomplished

Nine biomedical problems were solved with NASA technology. The following paragraphs describe these problems and the NASA technology used to solve them.

PROBLEM UM-56: Cleft Palate Air Flow Measurements

Current treatment of cleft palates in children requires accurate measurements of air emitted from their nostrils during speech. These measurements reveal changes in the palate's fissure history, response to treatment, and other characteristics. The measuring device must not alter the normal nasal air flow of the child by restricting nasal passages. However, previous tests indicate reasonably accurate air flow measurements can be made with one nostril blocked. An apparatus that either disturbs the child or makes him uncomfortable can be responsible for inaccurate measurements.

The NASA Tech Brief B68-10438 (Figure 1) was sent to the investigator who evaluated it as, "The described nosepiece respiration monitor appears to have the desired response and mechanical arrangement. More detail would be appreciated." The backup information was given to the investigator.

He evaluated the device as being of possible use in the clinic where a simple small portable device is needed to give a gross indication of nasal air flow of patients. A unit as described in the backup information was obtained and loaned to the investigator for use in the clinic. The unit is shown in Figure 2. He is presently evaluating the unit.

PROBLEM UM-73: Activity of Water

Freezing has long been a major method for preserving tissues. However, it does not allow the restoration of tissues back to a functional state. Many investigators believe this irreversibility is caused by the formation of ice crystals which damage the membranous structures of a cell.

Cryoprotective solutions, in which cells can be frozen and thawed without loss of physiological functions, are being studied. One characteristic which many cryoprotective agents have in common is the ability of the agent to bind water, and this characteristic can be used to predict the potential cryoprotective effect of proposed protective compounds. To measure this characteristic, it is necessary to determine the fugacity of an unknown (i.e., activity coefficient of unknown solution/activity coefficient of water).

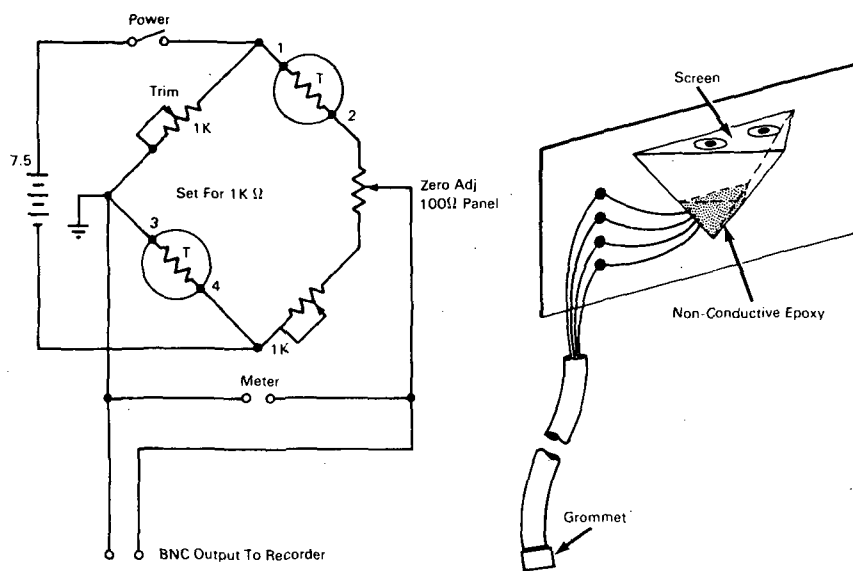

Figure 1 - NASA-Developed Respiration Monitor

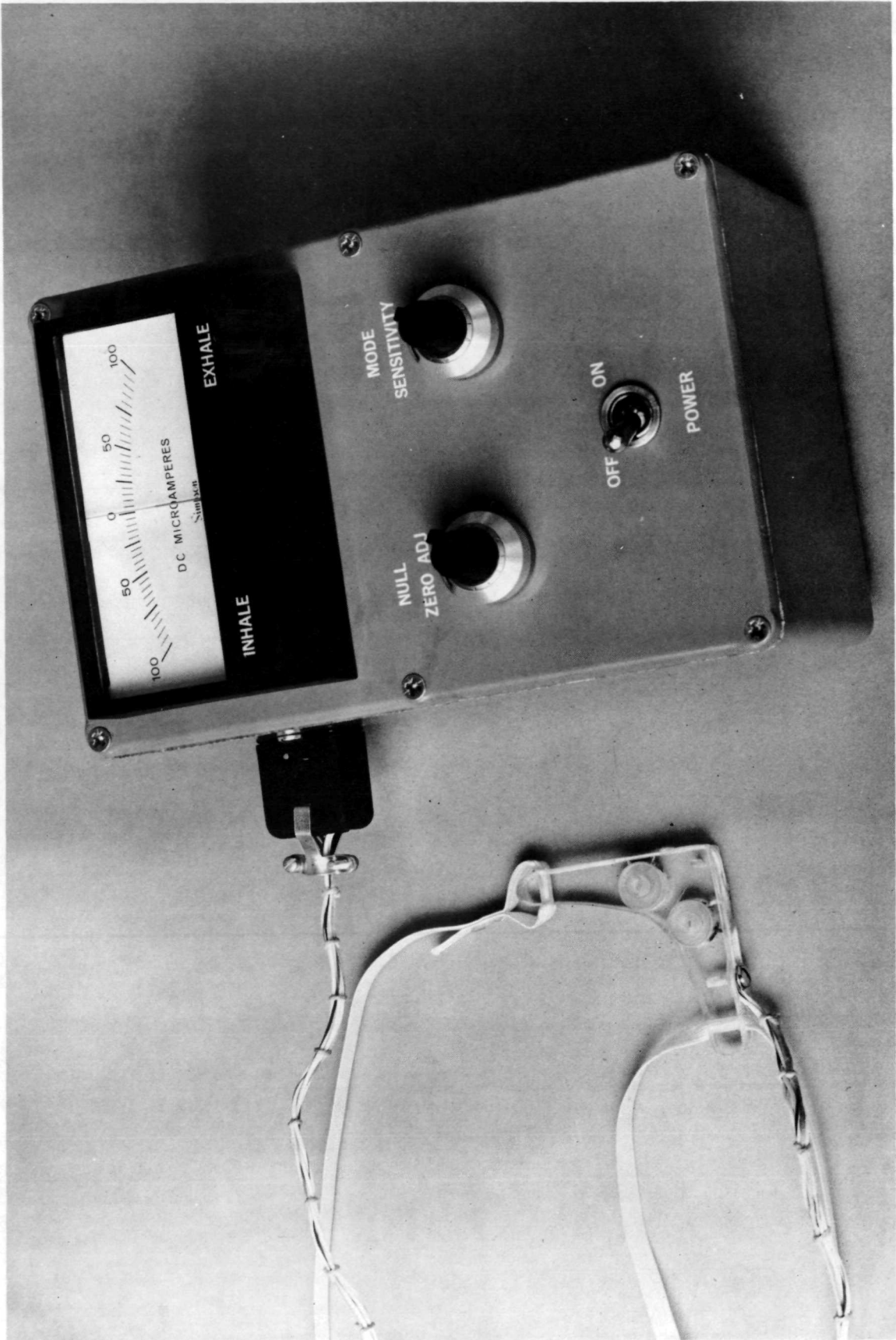

Figure 2 - Cleft Palate Air Flow Monitor

Conventional methods for determining fugacity, as by measuring a solution's freezing point depression, are not generally applicable to solutions of cryoprotective agents. One reason is that the freezing point cannot be measured reproducibly on a single sample.

The investigator is developing another method for directly measuring the activity coefficient of solutions with an electronic probe. He has found that the presence of proteins often interfered with measurements by his instrument. In order for the investigator to proceed with further development of his instrument, it is necessary to evaluate the effects of protein on fugacity. To perform this study, information is needed on activity coefficients of several types of solutions.

An ARAC search was run which revealed several relevant documents which were requested by the investigator. Two of the documents were evaluated as possibly being useful in the calibration of his laboratory instrument and for standardization. The investigator was contacted in November, and the status of the problem reviewed. He said the information in the two documents has been, and is being, used. Briefly, he is making known solutions of sodium chloride and potassium chloride and measuring the water activity. His results are then compared with the data tables in the documents to standardize and periodically to check his equipment. The data he is using are contained in the two following documents:

1. N63-19813, "The Activity Coefficients of Hydrochloric Acid and Sodium Chloride in Hydrochloric Acid-Sodium Chloride Mixtures," Oak Ridge National Laboratories.

2. N66-18236, "Model Osmotic Coefficients and Water Activities for Various Electrolytes," Soreq Research Establishment, Israel Atomic Energy Commission, Yauneh.

PROBLEM UM-130: Battery State-of-Charge Indicator for Powered Prosthetic Device

The investigator has built a powered hand prosthetic device and is evaluating it in his clinic (Figure 3). The device is electrically powered and he wants to monitor the total current drain on the battery pack during normal daily activity. Care must be taken to prevent excessive discharging of the batteries causing damage. He is also interested in optimizing the size of the battery pack so excessive batteries will not cause added weight.

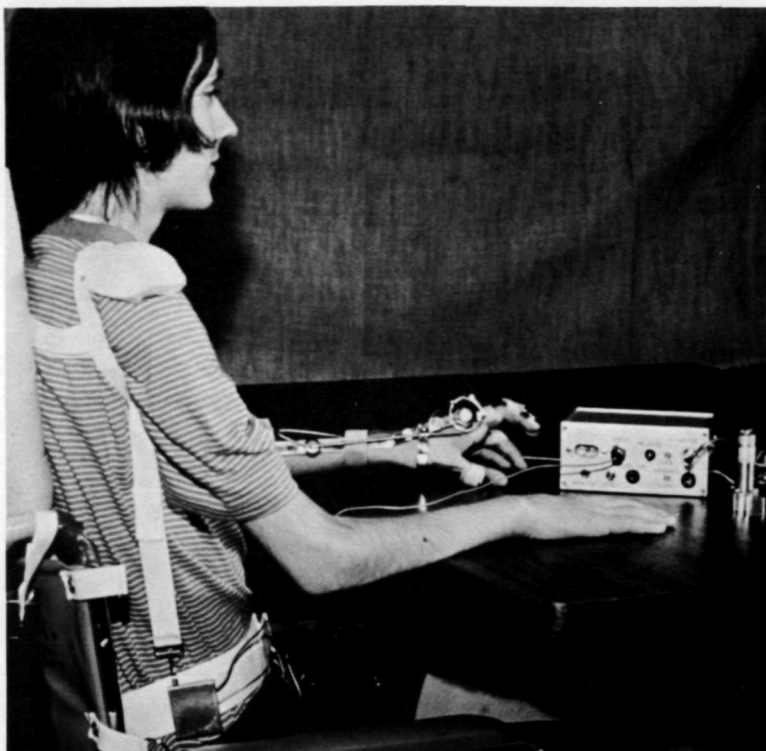

Figure 3 - Powered Prosthetic Device



Figure 4 - Battery State-of-Charge Indicator (Coulometer)
Attached on Left Side of Prosthetic Power Pack

The technologist was familiar with the electrochemical coulometer circuit that was used by NASA to monitor the condition of spacecraft batteries. The NASA Technical Note NASA TN D-5773 titled "Mercury Electrochemical Coulometer as a State-of-Charge Indicator," was sent to the investigator. He used the ampere-hour type state-of-charge indicator for a DC system as described on page 4 of the technical note (Figure 4). This circuit measures the total battery current.

The batteries in the prosthetic power pack are charged to full capacity and the coulometer set to zero each night. During the day, while the patient is carrying out his daily routine, the total current from the power pack is monitored. At the end of the day, the amount of power used is recorded and this information is used to size the power pack so there will be sufficient capacity for this individual's activity but not so much excess as to cause unnecessary added weight and bulk.

The benefits from the use of the state-of-charge coulometer will be in the form of better design data for prosthetic power packs and the modification of power packs to individual requirements.

PROBLEM SL-2: Correction of Physiological Pressure Measurements

Fluid-filled, remote-reading manometers are the most frequently used method of measuring physiological pressures. They are relatively simple, safe, inexpensive, and versatile (injection and sampling). However, an important disadvantage is the distortion of the shape of the pressure pulse by the thin bore tubing (catheter). This distortion is particularly serious, for instance, when trying to compute the rate of change of pressure with respect to time (dP/dt) or when attempting to measure the difference of maximum pressure (ΔP) between two catheter-tip locations. (dP/dt may be used as a measure of the strength of ventricular contractions; ΔP may be used to determine the extent of aortic valve malfunction.)

Catheter characteristics vary from type to type and from size to size. Within one type and size, there are variations from one catheter to the next. Therefore, a simple method of calibration is needed.

Under NASA contract (T-37761-G), Dr. Stegall at Brooks AFB developed a simple, inexpensive, sinusoidal pressure generator for calibrating catheters. The design of the generator was published in the J. of Appl. Physiol. and used subsequently for fabricating a similar device for the Cardiology Department of St. Luke's Hospital in K.C. (Figure 5). It is presently used in a study involving 75 patients, usually teenagers with cystolic murmurs, in order to determine the presence and severity of organic heart disease.

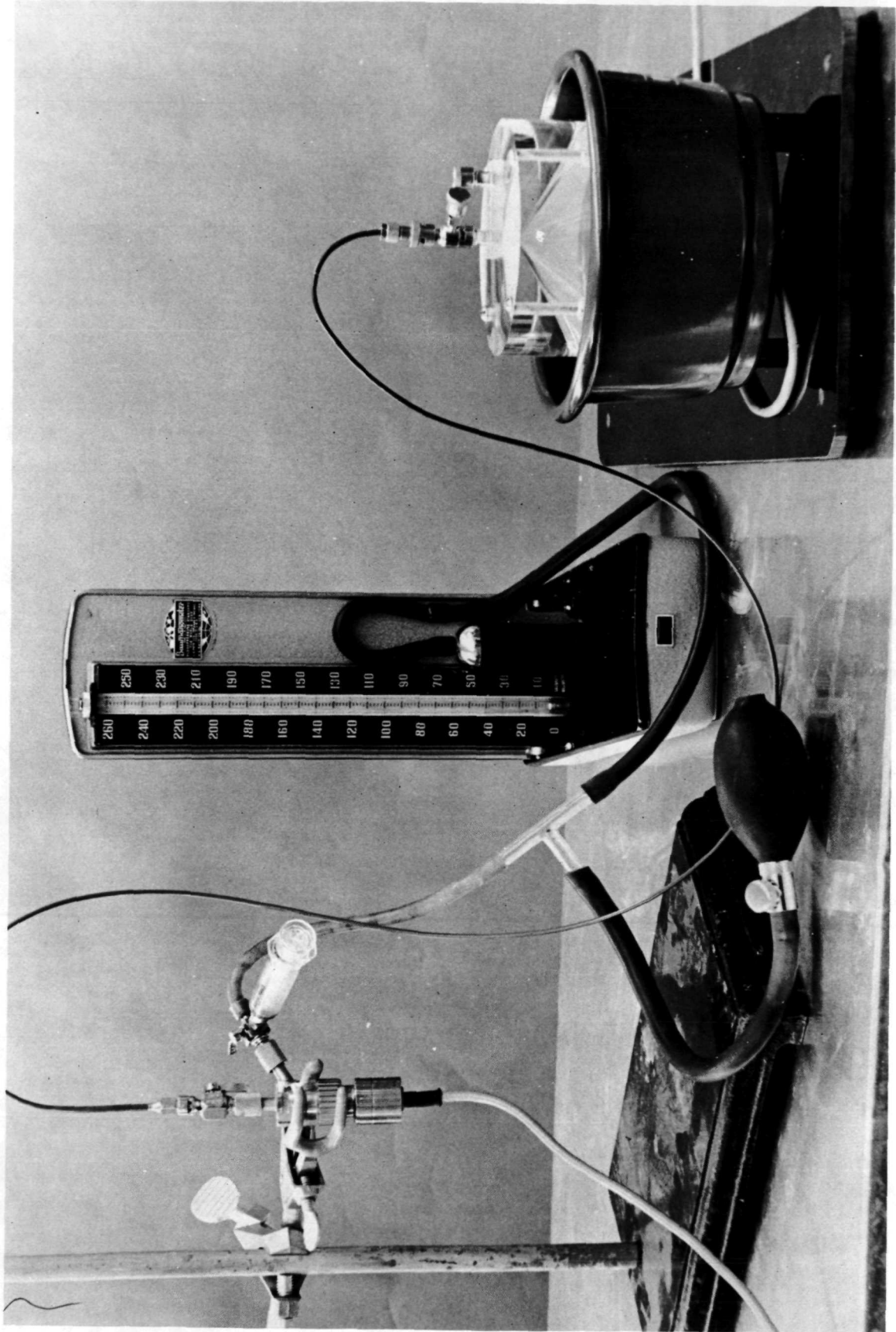

Figure 5 - Pressure Transducer Calibrator

PROBLEM MCGH-3: Current Limiting Circuit

Electroanesthesia (EA) holds great promise for animal and human surgery, particularly for procedures in which drugs cannot be tolerated. Sances (1965) and Short (1967) have shown that diffuse, time-changing electric currents applied transcranially through external electrodes can produce unresponsiveness in experimental animals permitting major surgical operations.

The portable electrical anesthesia generator presently under development incorporates silver-zinc batteries that must be charged at 2 volts per cell at a rate of 2 amperes. A voltage source regulated at the desired open circuit voltage would draw more than 2 amperes when connected to the discharged battery. Therefore, a current limiter is required to prevent damaging the batteries.

NASA Tech Brief 70-10232 describes a 2-terminal current limiter which has been incorporated in the portable electroanesthesia generator.

PROBLEM MRI-1: Air Shower for Rodent Quarters

The investigator is currently performing preclinical toxicity evaluations of new antimalarial compounds for the Army. The results of these studies aid in the selection of safe, effective agents for clinical trials and provide a basis for choosing the initial human trial dose. Some of these antimalarial agents are currently being used in Vietnam.

Part of the preclinical evaluation requires that each agent be administered to rats, 2-3 times each week for 2 years. In order to insure maximum opportunity to detect drug-induced changes, these rats must be maintained in an environment free from infectious microorganisms, the most common of which are plueropneumonia-like organisms (PPLO). These microorganisms can rapidly infect a rat colony and produce pathogenic signs and lesions which will mask most drug toxicity.

The investigator, aware of this problem, conducted an initial (6-month) study in an animal room which is isolated from all other rodent quarters and supplied by a separate ventilation system containing large charcoal filters. This precaution only delayed the infection of this colony by PPLO by 2-3 months. After analysis of the situation, the investigator decided it was necessary to build an isolation room for chronic rat studies. To design this room, he obtained commercial information about the facilities used by rat breeders who raise germ-free animals. This information showed that a completely autonomous unit with its own heating, ventilating, humidifying, dehumidifying, filtering and cooling system, providing a bacteria-free atmosphere, was needed. It was also found that a series of locks for removal of clothes, antiseptic scrub-up and the donning of sterilized garments were needed.

NASA TECH BRIEF



NASA Tech Briefs announce new technology derived from the U.S. space program. They are issued to encourage commercial application. Tech Briefs are available on a subscription basis from the Clearinghouse for Federal Scientific and Technical Information, Springfield, Virginia 22151. Requests for individual copies or questions relating to the Tech Brief program may be directed to the Technology Utilization Division, NASA, Code UT, Washington, D.C. 20546.

Two Terminal Current Limiter

This simple and inexpensive device offers current limiting protection for dc electronic circuits, and can be used to replace fuses and circuit breakers directly with great speed, accuracy and reliability.

In many phases of electronic development, the power supply source can be overloaded or delicate components can be damaged when excessive currents flow due to accidental shorting, component failure, or circuit changes. Fuses and circuit breakers are commonly used for protection, but these devices are neither fast enough to cope with instantaneous over-currents nor accurate or reliable enough to provide suitable protection for some power sources and some solid state experimental units.

A two terminal current limiter, which could be fabricated in the size of a type 3AG fuse, can be used instead of a fuse to provide sensitive protection for dc power supplies or experimental solid state devices under test and development. The device consists of two transistors and two resistors. The necessary supply voltage for operation is obtained from the power source being protected, with the load functioning as the return to the power source from the device. One of the transistors acts as a series element which allows current, up to a desired maximum, to flow to the load. One resistor provides a suitable bias for the series transistor to permit such current flow. A second sensing resistor interposed between the series transistor and the load, provides bias for the second transistor. Normally this bias is low enough to prevent conduction by the second transistor. The collector of the second transistor is connected to the base of the series transistor to reduce the bias applied to the series transistor. When current in excess of the desired maximum flows through the sensing resistor as a result of a cir-

cuit malfunction or a short across the load, the voltage drop across the sensing resistor rises to a value which is sufficient to bias the second transistor into conduction.

When the second transistor turns on, it reduces the bias of the series transistor to limit the amount of current that can flow through the series transistor so that it cannot exceed the desired maximum. The magnitude of the desired maximum current flow can be varied by changing the value of the sensing resistor.

The figure shows a comparison of the two terminal device and an ordinary limiting resistor used in series with the load as a protective device. As current in the

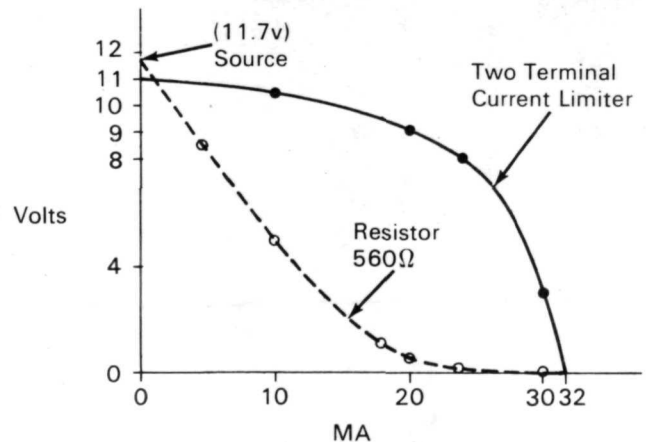

Comparison of Two Terminal Device and an Ordinary Limiting Resistor

load rises, the voltage available for the load using a limiting resistor drops in accordance with the load current. With the two terminal device, the voltage remains reasonably constant until the current limiting

(continued overleaf)

point is reached, at which the voltage drops sharply. Thus the two terminal device exhibits some of the characteristics of a voltage regulator.

Note:

Requests for further information may be directed to:

Technology Utilization Officer
NASA Pasadena Office
4800 Oak Grove Drive
Pasadena, California 91103
Reference: B70-10232

Patent status:

Inquiries about obtaining rights for the commercial use of this invention may be made to NASA, Code GP, Washington, D.C. 20546.

Source: L.S. Doubt of
Caltech/JPL
under contract to
NASA Pasadena Office
(NPO-11350)

The commercial isolation rooms were found suitable, except for the series of locks needed. Although these locks are important to the maintenance of the germ-free atmosphere, their added expense and space requirements made it necessary to seek alternatives. Because our BA Team has recently had experience with NASA clean room technology, this problem was submitted to us. We provided the investigator with the following NASA/AEC documents on clean room technology.

"Contamination Control Principles," by Sandia Corporation, Albuquerque, New Mexico, NASA SP-5045, N68-10384 (1967).

Lindell, C. F., W. J. Whitfield, and D. M. Garst, "Design Requirements for Laminar Air Flow Clean Rooms and Devices," by Sandia Corporation, Albuquerque, New Mexico, for NASA, N69-34607 (1969).

Powers, E. M., "Microbial Profile of Laminar Flow Clean Rooms," NASA Technical Memorandum, X-55320, Goddard Space Flight Center, Greenbelt, Maryland, N66-11212 (1966).

Beakley, J. W., W. J. Whitfield, and J. C. Mashburn, "Evaluation of the Efficiency of a Class 100 Laminar Flow Clean Room for Viable Contamination Cleanup," NASA Contract Report CR-78342, by Sandia Corporation, Albuquerque, New Mexico, N66-37585 (1966).

Klamerus, L. J., and M. I. Tillery, "A Study of HEPA Filter Efficiency in Sub-micron Particle Range," given at AEC/NASA Symposium on Contamination Control, Albuquerque, New Mexico, N68-29343 (1967).

Useller, J. W., "Clean Room Technology," Lewis Research Center, Cleveland, Ohio, NASA SP-5074, N69-33775 (1969).

Michaelsen, G. S., O. R. Ruschmeyer, and D. Vesley, "The Bacteriology of Clean Rooms," Contract Report 79114 for NASA, by School of Public Health, under Grant No. NSG-643, University of Minnesota, Minneapolis, N66-39919 (1966).

Michaelsen, G. S., O. R. Ruschmeyer, and D. Vesley, "The Bacteriology of Clean Rooms," NASA Contract Report 890, by School of Public Health, University of Minnesota, Minneapolis, Grant No. NSG-643, N67-38824 (1967).

"Contamination Control Handbook," by Sandia Corporation, Albuquerque, New Mexico, for NASA, N70-13566 (1969).

With the aid of these documents, the investigator found that one lock to the entrance of the isolation room would suffice, if the lock had a bacteria-free air shower. In addition, specifications for other parts of the isolation complex (i.e., ventilation system) were also found; thus it was not necessary to request specifications on commercial isolation rooms.

The isolation room has been built at MRI and is currently being utilized (Figure 6).

PROBLEM WU-7: Biocompatible Materials

New materials are needed for the construction of membranes, flexible sacks for artificial hearts, and flexible leaflets for prosthetic valves. A search for polymers which can be used in construction of prosthetic devices is the objective of this research program. It is desirable to set up a biomaterials program to specify and test materials for implants and prosthetic devices. High flexibility, extended fatigue life, and long-term in vivo compatibility are the specifications of the needed materials.

The availability of materials that are biologically compatible with the human body and medically approved is limited. The development of new materials has been plagued by the viewpoint that one material should be all things at once. This viewpoint is changing. During the past several years, compounded materials have been explored with the result that polymeric materials appear to have distinct benefits in superior fatigue life and thromboresistance.

An ARAC search was run on the problem and several documents sent to the investigator. Document N68-11474 (NASA), "Effects of Ethylene Oxide-Freon 12 Decontamination and Dry Heat Sterilization," described the effects of sterilization conditions on a number of products of interest in spacecraft applications. After classification according to function, the products were subjected to the type approval decontamination and dry heat sterilization procedures of the Jet Propulsion Laboratory (JPL) consisting of (1) exposure to ethylene oxide-Freon 12 for six cycles at 26 h (h = unit of cure time) each at 50°C and 50% relative humidity; and (2) exposure to dry heat for six cycles at 92 h each at 135°C in dry nitrogen. Extensive testing was performed both before and after exposure to ethylene oxide and again after dry heat exposure, to determine the changes in the physical, mechanical and electrical properties of the products.

The information and techniques presented have been used to prescribe sterilization for prosthetic materials in the operating room procedures.

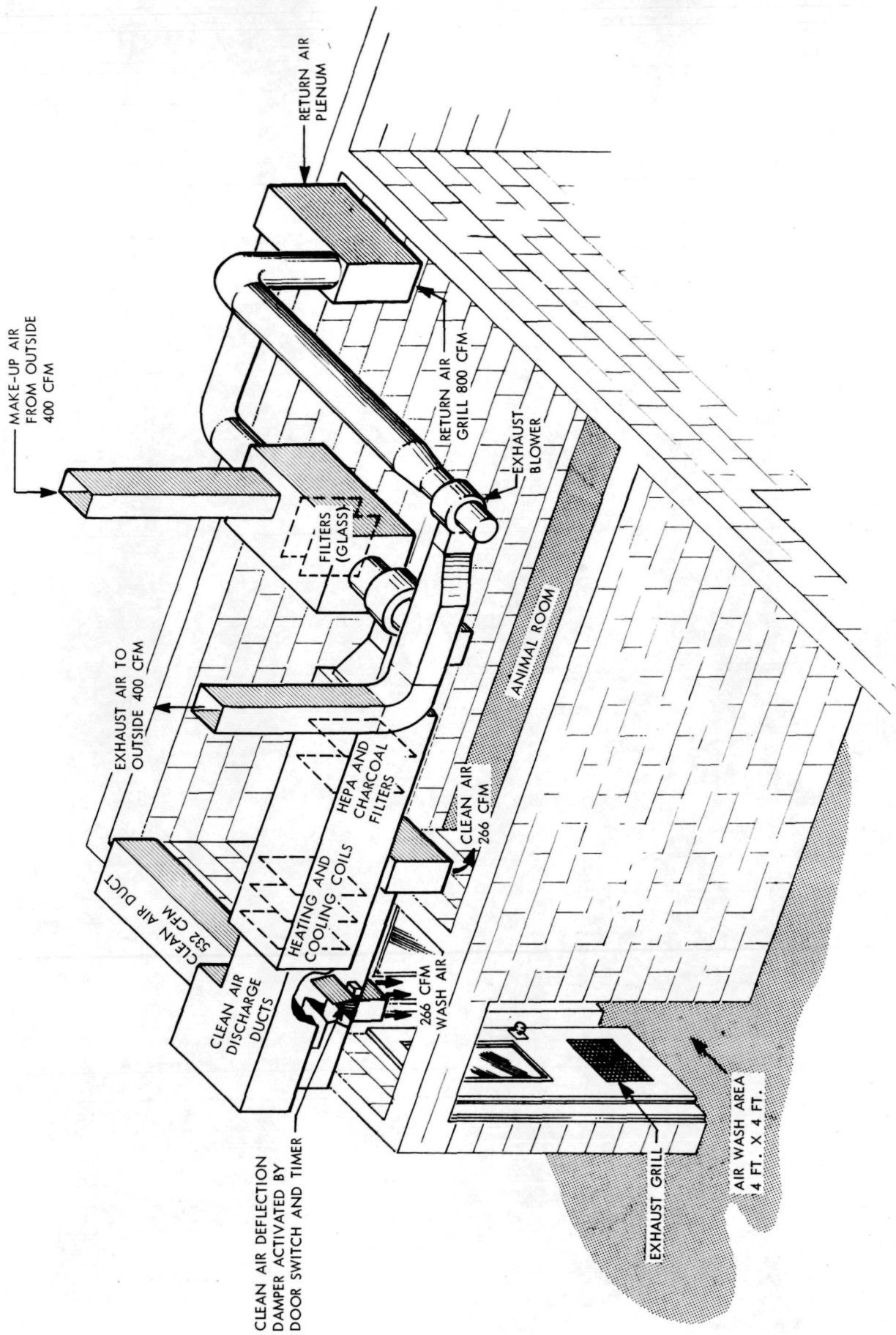

Figure 6 - Air Shower for Rodent Quarters

A second document, N69-15797 (NIH), "An Experimental Preparation for the Study of Thrombosis on Artificial Surfaces Under Controlled Flow Conditions," describes an experimental preparation which has been developed in which thrombus formation on artificial surfaces can be observed over a range of controlled blood flow conditions. Virgin blood; i.e., blood with no previous surface contact or activation, forms a stagnation point flow on the underside of a microscope cover slip. Direct observation of individual platelet settling, the existence of fibers, and the formation of large-scale platelet aggregates are possible without interruption of blood flow. A theoretical discussion of the effect of flow on various parameters which may be relevant to thrombus formation such as diffusion toward the surface, residence time near the surface, and stresses leading to detachment of material from the surface, is presented. Preliminary results on glass indicate a 1-min conditioning time before platelets settle followed by rapid attachment of platelets at a rate apparently limited by diffusion. The surface saturates with a monolayer of platelets until after 6-10 min large aggregates begin to form.

This technique is being used by the investigator in the evaluation of his thrombosis-resistant materials.

PROBLEM UCPA-3: Human Waste Management for the Handicapped

The United Cerebral Palsy Association (UCPA) Day School in Kansas City is involved in the rehabilitation and training of the handicapped. One of the problems at the school is the toileting of the patients while they are at the school. The school is dependent to a great degree on help that is supplied by volunteers. The volunteers can help the children with their toilet problems and there is little embarrassment to either the volunteer or the patient. As the patient grows older, the toileting operation becomes more sensitive to both persons involved.

Mr. Edwin B. Minter, Executive Director submitted the problem of waste management to the NASA Biomedical Application (BA) Team at Midwest Research Institute (Kansas City) to determine if any work that had been done by NASA could be used to aid his people. The BA Team searched the NASA data banks to retrieve any reference documents that might be applicable. One of the documents described the Hydro-john system that was developed by General Electric for NASA. This system was not the ultimate and total answer to the UCPA problem, but did appear to have some possibly good usable features. A prototype unit was located and made available for evaluation by UCPA and the BA Team.

A picture of the device as received is shown in Figure 7. To accommodate the handicapped, a supporting device was built that could quickly be attached (see Figure 8) to aid in properly locating the patient and providing him some degree of comfort. The unit was then installed at the UCPA school and the personnel instructed on its use.

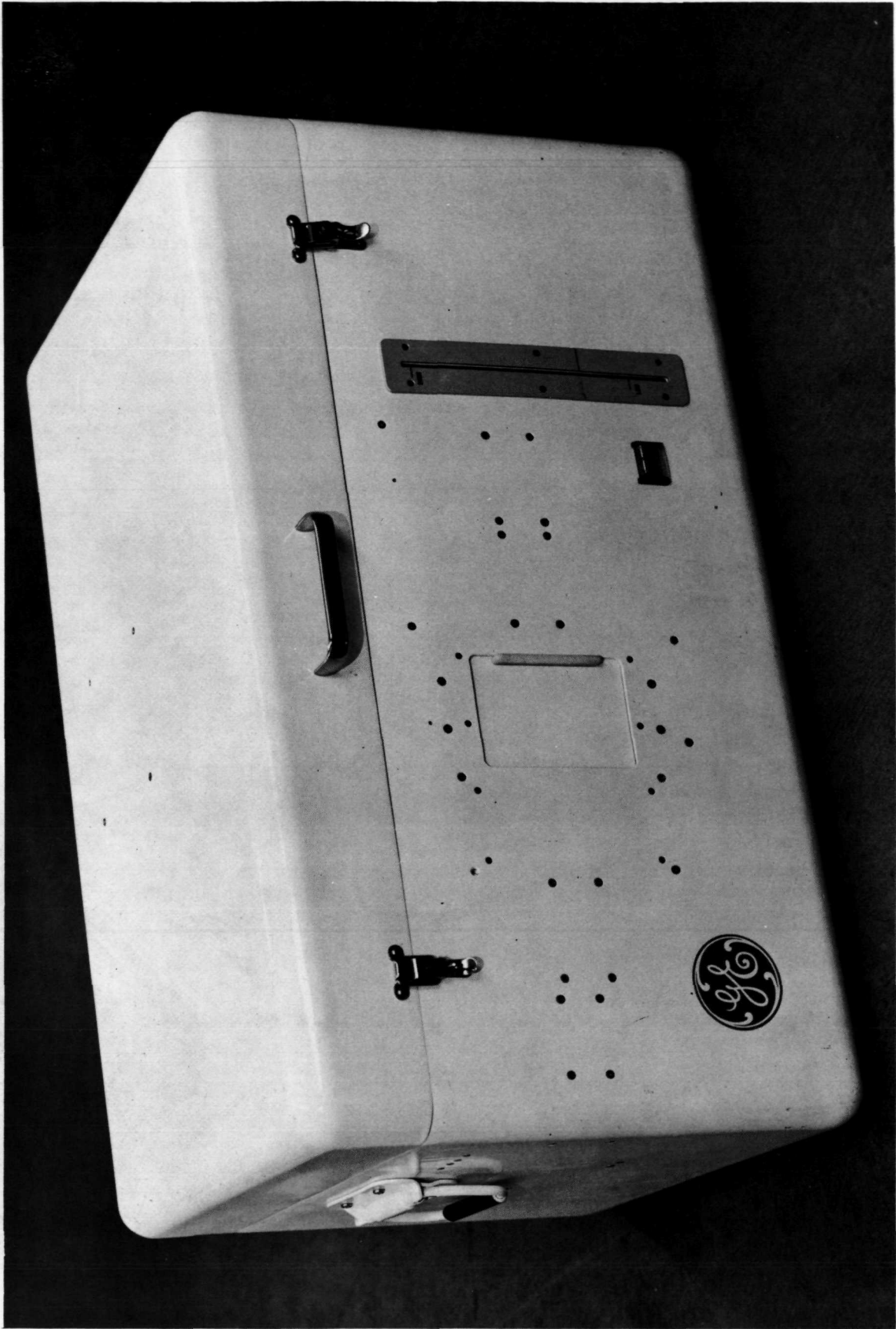
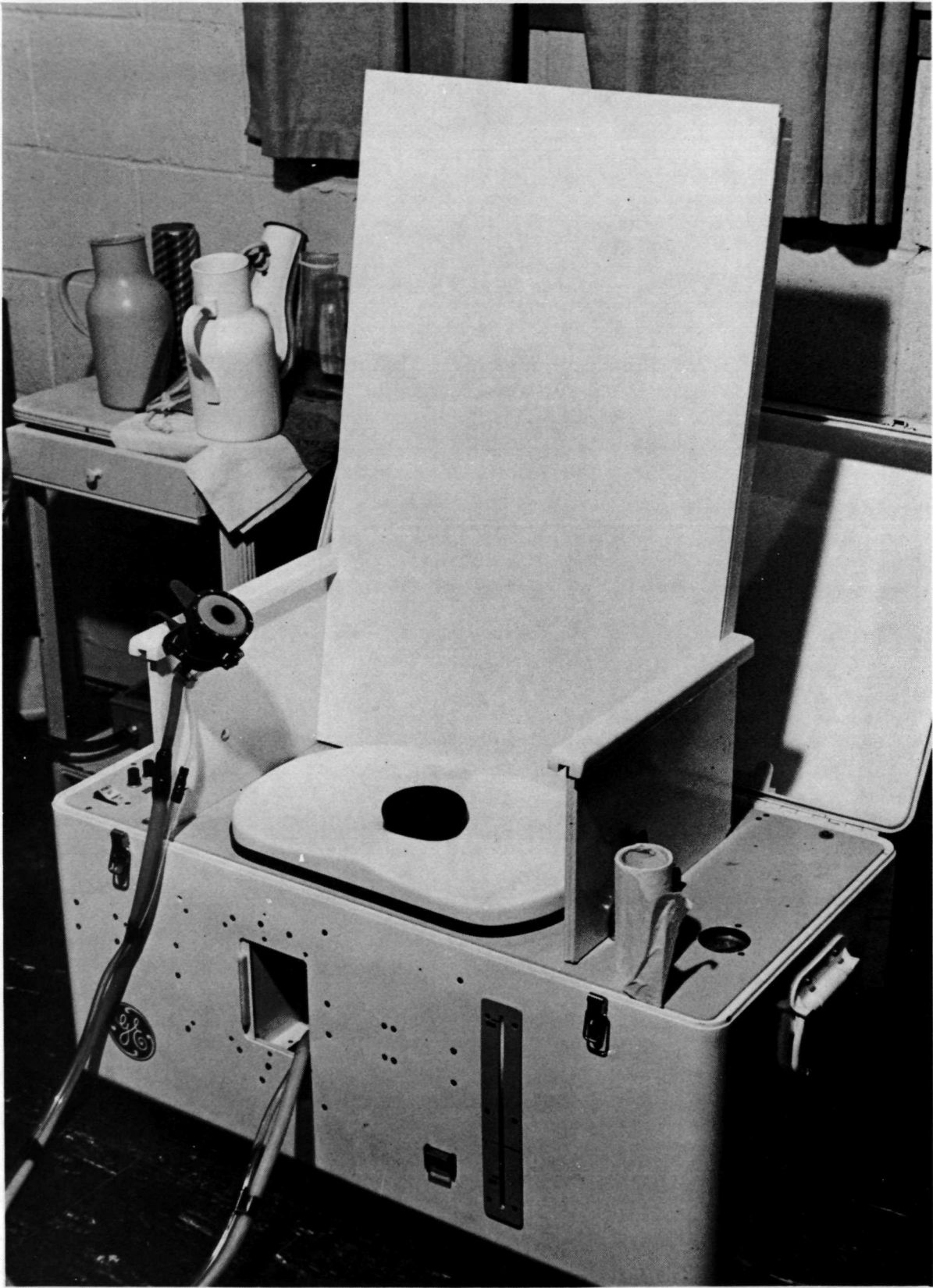

Figure 7 - Hydro-John as Received



The plan was to evaluate the system as a whole and determine its value. It was thought at that time that the capability of the system to clean and dry the anal area after defecation would be the most valuable feature. As it turned out that was not really true in this case. First, the patients were at the school for only about 3 to 4 hr each day and had trained themselves so they would not have to defecate while at the center; and second, the urination problems encountered while not being as severe when they occurred were also there and occurred much more regularly. The flushing urinal feature of the Hydro-john quickly became the most used and a very desirable feature.

The urinal is not the perfect device by any means and problems were encountered. The diaphragm broke and had to be repaired, the hoses were too short and had to be made longer, the urinal was too large physically for some patients, and it is limited to use by male patients. With some modification, however, it appears that the flushing urinal idea would have application as a portable unit that would be self-contained and could be used at the school or when groups travel and participate in activities away from special facilities (theaters, athletic events, etc.). Sketches were made of a possible unit (Figures 9 and 10) and they were sent to General Electric to see if they would be interested in constructing a prototype. No firm reply has been received yet.

The future application and modification areas that are being considered are: portable units, wheelchair units, female units, and home units. We believe that some of the features of the Hydro-john do have application in aiding the handicapped in their toileting problems.

PROBLEM CRS-1: Anti-Fogging Agent for Surgical Masks

The investigator is an orthopedic surgeon who uses a laminar flow clean room and a hooded isolation garment. The plastic bubble on the protective face mask (Figures 11 and 12), will fog under some conditions. An anti-fog agent was needed to apply to the plastic shield to prevent this fogging.

The BA Team conducted a manual search of NASA data and found the description of an anti-fogging coating that had been used at MSC. A small amount of the agent was formulated and sent to the investigator along with the backup information on the describing Tech Brief, B71-10149.

The investigator found the agent to be effective on the surgical mask and is now using it regularly. He also tried it in other situations with some success as mentioned in his letter (Figure 13).

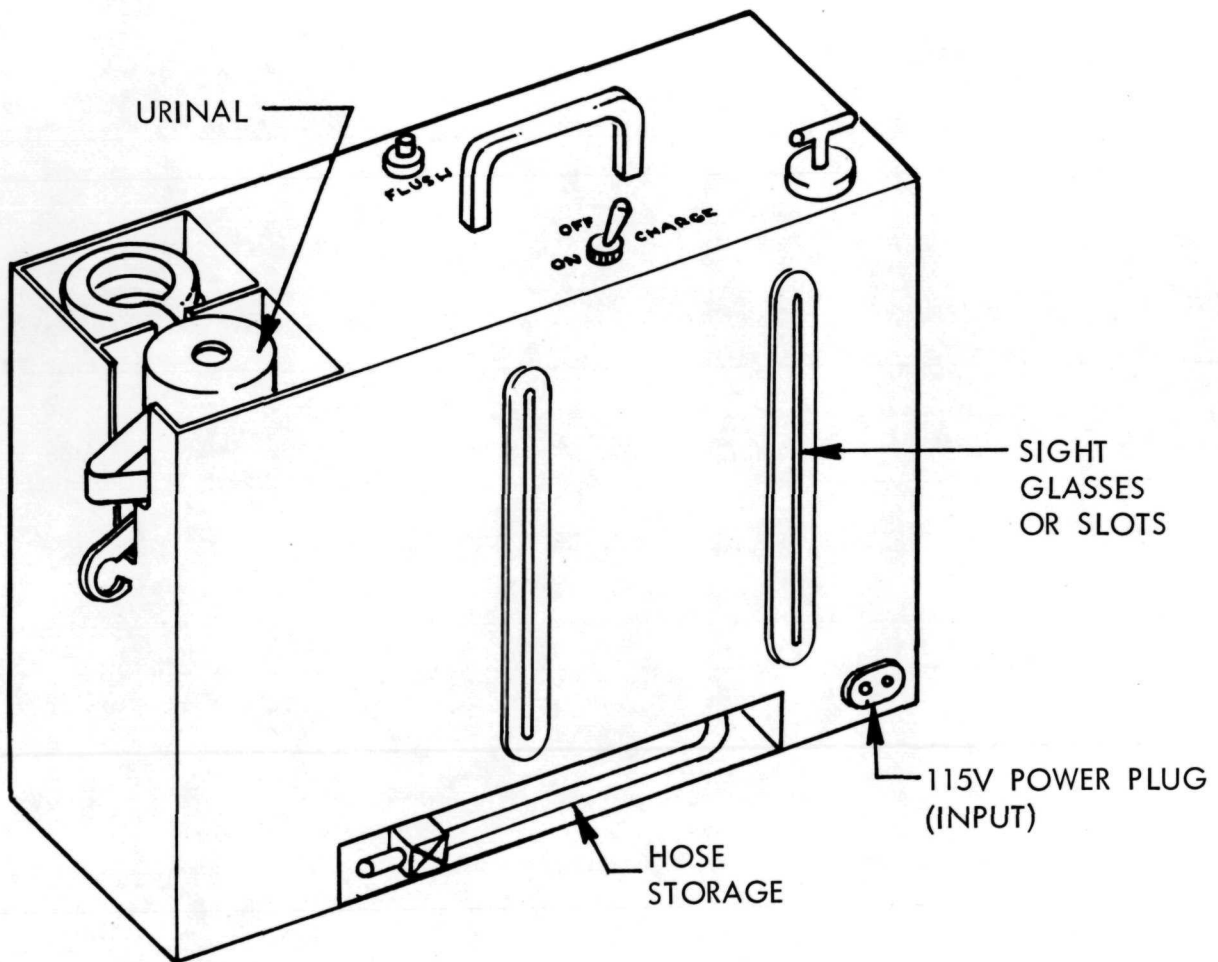

Figure 9 - Flushing Urinal

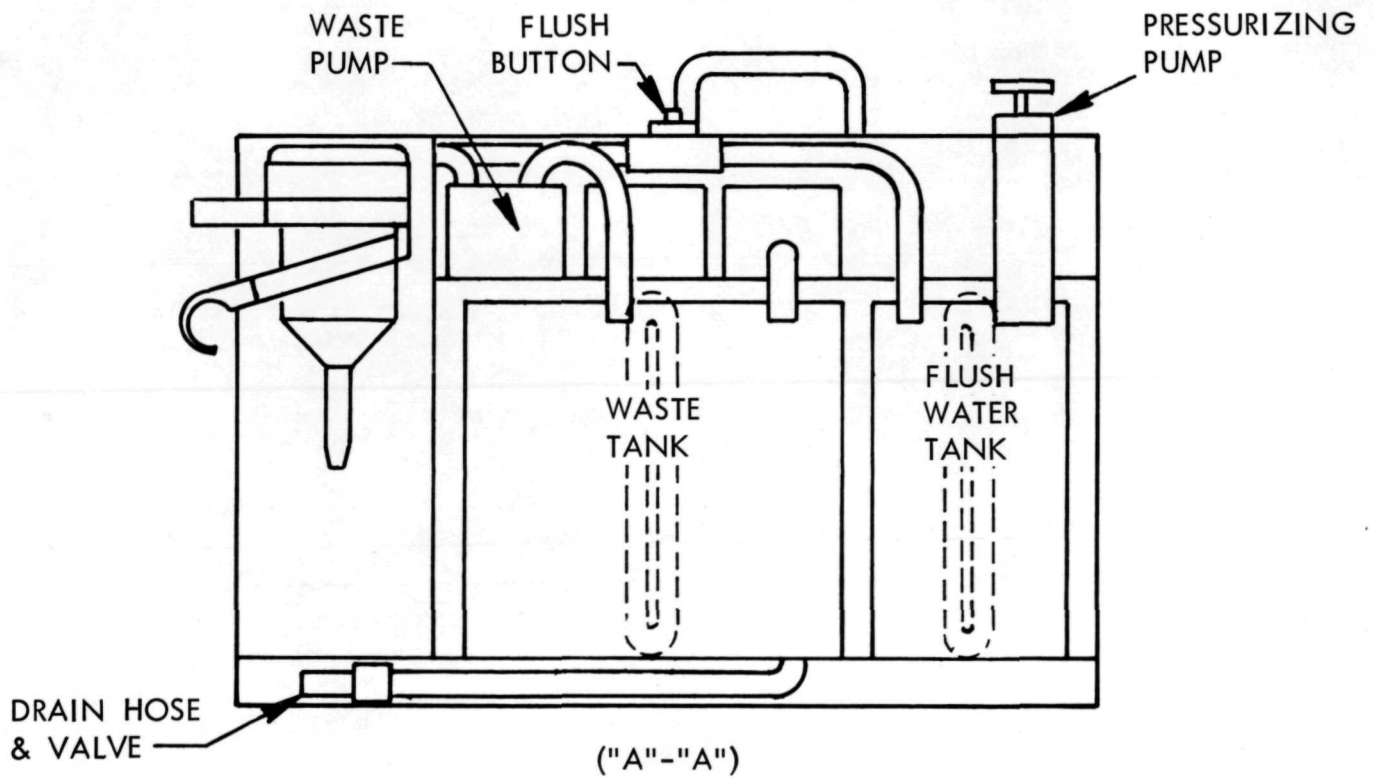
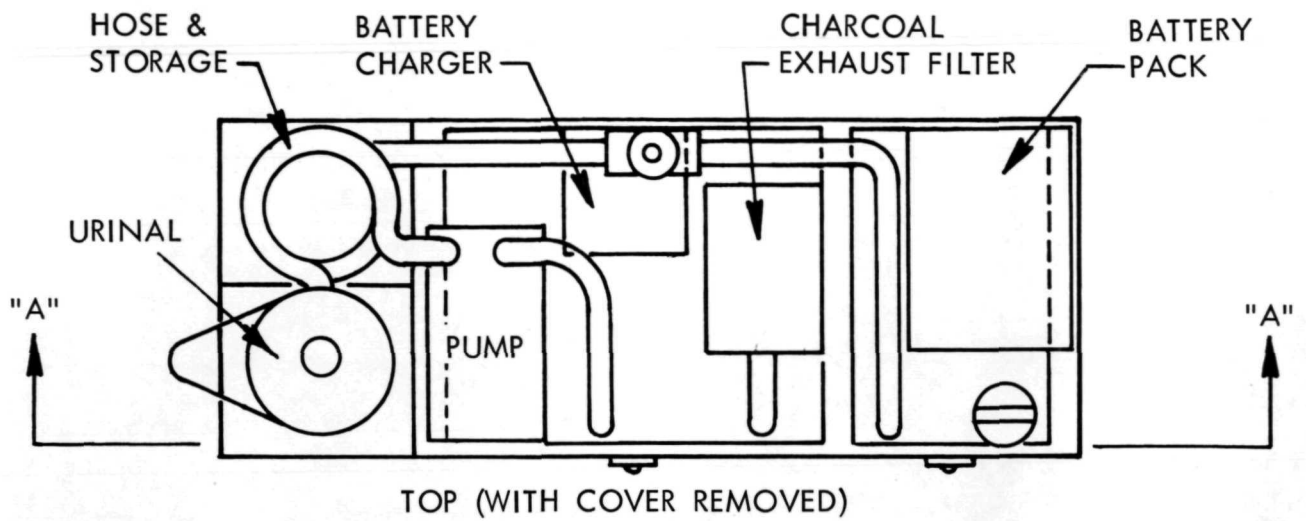

Figure 10 - Flushing Urinal (Cutaway)

NASA TECH BRIEF

Manned Spacecraft Center



NASA Tech Briefs announce new technology derived from the U.S. space program. They are issued to encourage commercial application. Tech Briefs are available on a subscription basis from the National Technical Information Service, Springfield, Virginia 22151. Requests for individual copies or questions relating to the Tech Brief program may be directed to the Technology Utilization Office, NASA, Code KT, Washington, D.C. 20546.

Inexpensive Anti-Fog Coating for Windows

An inexpensive, easily applied coating prevents the formation of fog on plastic and glass viewing windows. Immediate applications include anti-fog protection for deep-sea diving equipment, fire protection helmets, and windows of vehicles used in hazardous environments.

The basic composition of the coating includes: a liquid detergent, deionized water, and an oxygen compatible fire-resistant oil. The detergent contains a mixture of sulfonated aliphatic mono- and polyglyceryl compounds of the general formula

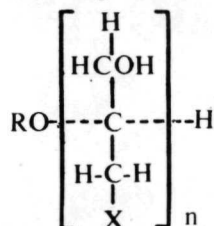

where R is an alkyl radical and X is chlorine, hydroxyl or a water-soluble sulfonic acid salt radical. The silicone-based oil is a phosphate ester of the triaryl phosphate type, preferably a triaryl phosphate derived from reacting phosphorous compounds with cresylic acid. Other acids may be used, however, where flammability is not a consideration.

The coating is prepared from a composition of 35 parts commercial liquid detergent, 5 parts deionized water, and 4 parts silicone-based oil. The components are combined and agitated until the mixture

is completely emulsified. Two thin coatings are applied to the transparent surface and buffed lightly with a lint-free cloth. The composition has been used successfully to prevent fogging of visors under maximum metabolic load for 5 hours and longer.

Note:

Requests for further information may be directed to:

Technology Utilization Officer
Manned Spacecraft Center, Code JM7
Houston, Texas 77058
Reference: TSP71-10149

Patent status:

This invention is owned by NASA, and a patent application has been filed. Royalty-free nonexclusive licenses for its commercial use will be granted by NASA. Inquiries concerning license rights should be made to:

Patent Counsel
Mail Code AM
Manned Spacecraft Center
Houston, Texas 77058

Source: Dorrie Leslie Carmin, Jr., and
Harry Doyle Morrison of
Brown and Root-Northrop
under contract to
Manned Spacecraft Center
(MSC-13530)

Category 04



Figure 11 - Isolation Garment With Face Mask

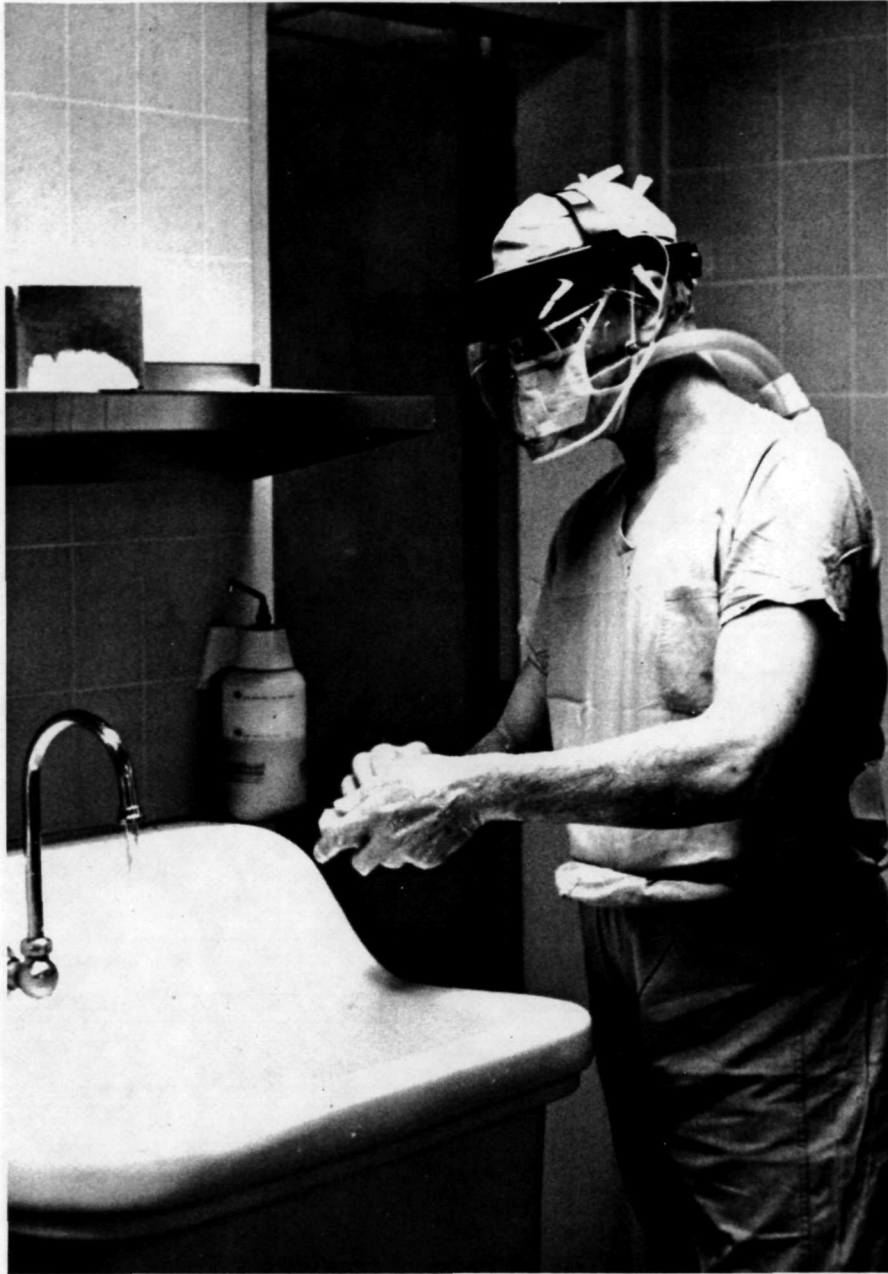

7080 HOLLYWOOD BOULEVARD
LOS ANGELES, CALIFORNIA 90028
TELEPHONE 464-7217

KENNETH B. JACQUES, M.D.
JOHN H. FREEMAN, M.D.

3875 WILSHIRE BOULEVARD
LOS ANGELES, CALIFORNIA 90010
TELEPHONE 387-6145

ORTHOPAEDIC SURGERY

CHARLES O. BECHTOL, M.D.
HIP SURGERY

October 5, 1971

C. K. Doll
NASA, Biomedical
Application Team
Midwest Research Institute
425 Volker Boulevard
Kansas City, Missouri 64110

Dear Mr. Doll:

Thank you very much for the bottle of the anti-fogging agent described in the NASA Tech Brief 71-10149. I have given it a try. It works very well in the operating masks. I have also tried it on the windshield of the car. Here, I find a slight disadvantage in that, with the light shining through the windshield, from either oncoming headlights or a low lying sun, the sweeps of the polishing rag cause some haziness of the windshield. I have continued to polish it and this is gradually diminishing. However, I do not know whether I have polished all of the agent off so that it will not work. The climate here, has been such recently, that there has been no possibility of finding out whether it will really anti-fog the inside of the windshield. I have also placed it on the bathroom mirror, which frequently gets steamed up as the weather gets a little colder, after the shower has been used by several children one after the other. Once again there is a slight haziness of the mirror brought on by the material. This however, is not present to a serious degree. In the case of our operating masks, this degree of haziness is not a problem.

Thank you also for the information on the lighting problem. We are still working on this and I am sure a satisfactory solution will be forthcoming before too much time has elapsed.

With regard to the rubber gloves, we have not had any significant problems. However, thank you for your information along this line.

Very truly yours,

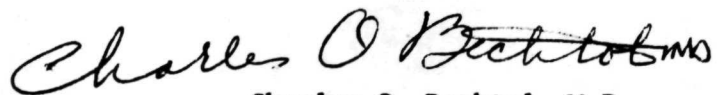

Charles O. Bechtol, M.D.

COB:fp

C. Potential Technology Applications

In addition to the transfers of aerospace technology listed above, the team found relevant aerospace technology which holds potential for solving 22 other biomedical problems. Since the application of NASA technology is pending, these problems are classified as potential transfers. The following paragraphs describe these problems and their potential solutions.

PROBLEM SL-1: Management Information Center

St. Luke's is a teaching hospital that presently runs training programs for nurses (student and in-service), x-ray technicians, practical nurses, medical technologists, aids and orderlies, interns, resident MD's, medical students, pharmacy students including such specialized courses as operation of intensive care centers. In addition, St. Luke's will be one of the back-up hospitals for the new UMKC Medical School. The hospital currently has a library, meeting and training center in the working drawing stage. Several areas in this building have been designated for training purposes. The one room they have most hopes of us influencing with NASA technology is approximately 20 ft. x 32 ft. with space available at one end for a rear projection arrangement. They desire this room to have a combination of audio-visual, closed circuit TV, display surfaces, and devices to allow the most effective training of medical personnel. St. Luke's has the funds to build and equip this center and plans to open the new facility in 1972.

Due to the time delay in constructing the new building, several interim areas are being considered in current buildings.

A plan (Figure 14) was developed based on one of the candidate locations and has been technically accepted by both the associate administrators and the investigator. The plan utilized the designs and specifications for display devices, rear screens and equipment from the Sky Lab/Space Shuttle Management Center at MSC, furnished by Mr. Leo Zbanek, Deputy Chief Engineer, Manned Spacecraft Center.

A recent change in the availability of one of the primary locations has slowed the completion of this transfer.

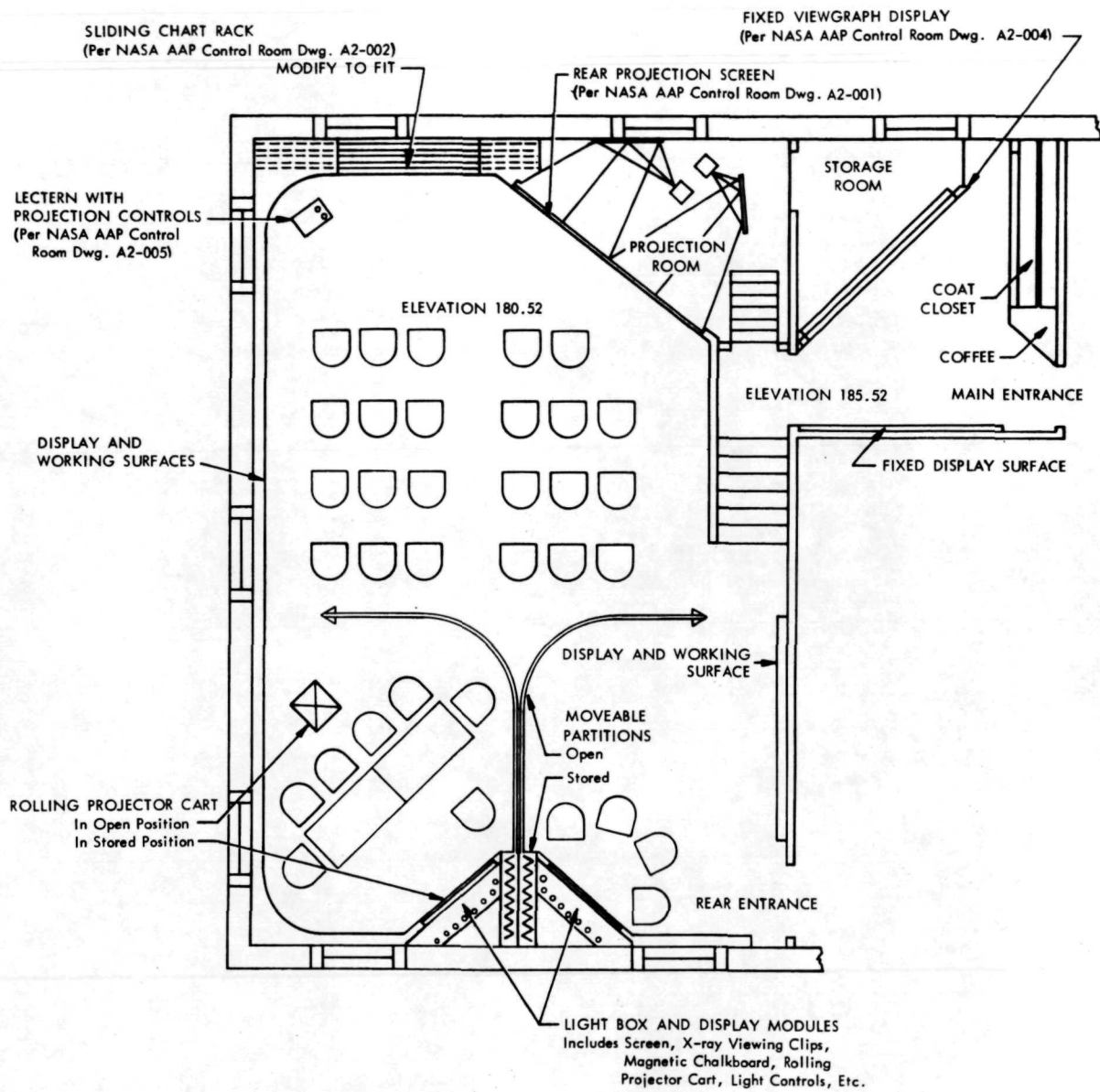

Figure 14 - A Proposed Hospital Management Center

PROBLEM IU-55: Miniaturized Pulsatile Pump

Organ preservation is important to the viability of organ transplantation. Medical researchers and practitioners would like to preserve an organ in a functional state for 24 hr or longer. Several organ preservation systems are available but are not acceptable because of their large size and weight which precludes their use over long distances. One such system for kidney transplants uses the principle of dynamic perfusion (forcing fluids through the organ) at low temperatures. The investigator believes that components of this system could be reduced in size. One miniaturized component needed is a pulsatile pump which can be programmed to deliver an adjustable volume at specific intervals.

The investigator was sent Document N65-17559, "Four Fluid Amplifier-Controlled Medical Devices," which described an artificial heart pump. Further information was obtained (AS-684311) and his evaluation was that he would like to obtain one of the pumps to try. The U.S. Army Research and Development Command was contacted and they are trying to locate a unit for him.

PROBLEM UM-19: Intercardiac Transducer

The investigator would like to have a very small transducer to monitor intercardiac heart sounds. It must be no larger than 1 mm in diameter, and as short as possible, 1 cm or less. The leads should be at least 135 cm long. The transducer will be inserted down a heart catheter in the examination and study of the human heart. High gain amplifiers will be used and the highest possible signal-to-noise ratio is desired.

The miniature electromechanical tunnel diode transducer described in NASA TN D-5451 (see Figure 15) has the necessary characteristics to make such measurements. The investigator has agreed to evaluate one of the transducers if they are available. The transducers are now on the market, and one has been obtained for his evaluation.

PROBLEM UM-49: Measurement of Hand Motion

The investigator is working with patients, children primarily, who have muscle control disorders. These patients are receiving rehabilitation training and it is very difficult to determine the progress they are making. At the present time, the patient is observed by the therapist and a subjective evaluation is made. If the patient progresses slowly and he receives treatments for a long period of time, as long as several years, it is difficult to get an accurate plot of his progress.



Figure 15 - Tunnel Diode Transducer

"In conclusion, it appears that the general requirement can be met with a magnetic plotting concept. The procurement of special equipment would cost about \$5,000 plus data acquisition system and programming services. The signal levels would be sufficiently large to permit successful use in the clinical environment and except for the magnetic apparatus, all equipment could be concealed from the view of the patient."

The investigator has submitted a proposal to NASA TU Headquarters for funding through one of the NASA centers.

PROBLEM UM-63: Implantable Materials and Lubricants

In some severe cases of arthritis, the cartilage that lubricates skeletal joints has been damaged or diminished to the extent that the use of the joint is lost. Arthritic damage to this degree in joints involved in locomotion--such as hip joints--cripple the sufferer. One treatment of this problem involves surgical exposure of the joint surfaces, smoothing them, and surfacing one joint surface (such as a ball in a ball- and socket-joint) with polished stainless steel. This metal-coated ball surface can eventually damage and penetrate its mating socket.

The investigator seeks a lubricant that can be injected between arthritis-damaged joints to replace or assist the damaged cartilage. This lubricant could be applied by means other than through injection, but have an application method involving as little surgery as possible. The lubricant should tend to remain between the bearing surfaces.

The investigator also seeks specialized materials that could firmly cover skeletal joint bearing surfaces in arthritic cases where artificial cartilage or other lubricants cannot be applied.

The investigator was referred to the Lubrications Branch at Lewis Research Center. They have been actively working with Dr. Harlan Amstutz (UCLA) to develop new materials and lubricants (polyimides) for hip prostheses. Contact between the investigator and Lewis Research Center proved informative for both parties and the investigator is very optimistic about the Center's cooperation toward achieving an injectable lubricant.

PROBLEM UM-129: Stethoscope for High Noise Environment

The investigator has a mobile infant care van that is used to transport critically ill infants from outlying areas into the University Hospital. The infants must be monitored during transportation and the operation of the van engine and traffic causes considerable noise inside the van making the use of a regular stethoscope very difficult.

The investigator was sent document N70-26928, "Two Electronic Stethoscopes for Use in High Noise Environments," and his evaluation was that an instrument like this would be very useful and could he obtain the loan of a unit to try.

The group evaluating the device at Brooks Air Force Base was contacted and no stethoscopes were available for use because the units described did not work in the field. They are presently having an ultrasonic doppler unit built at Wright-Patterson and will notify us when a successful instrument has been built.

PROBLEM CU-6: Ultraminiature Cardiac Manometer

The treatment of oral diseases required an improved understanding of the mechanics of oral biological systems. This particular problem concerns the mechanics of operation of salivary glands. The investigator seeks recently-generated measurement data and instrumentation that measure the secretion of fluids and electrolytes from these glands. His investigations indicate a hydrostatic pressure component may be generated across the secretory epithelium (membrane over glandular cavity), by the intraglandular vascular pressure to produce the secretions. It would be useful to be able to measure the intraglandular vascular pressures during blood outflow and glandular secretion measurements that are made when arterial inflow to area of the gland is stopped. The investigator has noted a very close correlation between the durations of blood outflow and secretion when the arterial inflow is interrupted.

These measurements require a pressure-sensitive device fashioned into the shape of a tiny needle-like tube, which can be pushed into the glandular parenchyma (essential gland wall tissue as opposed to the supportive framework). The device's pressure-sensitive surface would come to rest against the external surface of the intraglandular vessel. If the pressure sensor can be maintained in this position by a precision micromanipulator, it should provide the needed data. The investigator believes 15-20 mm Hg will be found in the intraglandular pressures of duct. The transducer and catheter can be no more than 0.5-1 mm in diameter.

The original potential transfer on this problem involved the use of a miniature diaphragm type capacitance transducer capable of being mounted on the end of a cardiac catheter. The transducer is described in NASA Tech Brief 67-10669 but is not available due to developmental problems.

An alternate potential solution was revealed by a NASA literature search in an article A70-15772, "Continuous Recording of Hydrostatic Pressure in Renal Tubules and Blood Capillaries by Use of a New Pressure Transducer." The investigator stated that the article reveals research application much

similar to his work. A second alternate potential solution is the ERC-developed tunnel diode transducer described in NASA TN D-5451. The investigator has been contacted now that this transducer is available and he is interested in evaluating it.

PROBLEM KU-35: Respiration Volume Flowmeter

During surgical anesthesia, it is essential that the respiratory state of the patient be under continuous observation. The patient is connected to a closed circuit anesthesia machine in which the machine gas flow directly represents patient flow. The gas composition may vary considerably as the anesthetist varies the anesthetic mixture. It may contain appreciable concentrations of halogenated hydrocarbons or explosive mixtures.

The anesthetist's most important consideration is the volume of gas moved per breath. Of secondary importance is volume move per minute and instantaneous flow.

The possible application of a spirometer (Figure 16), developed at Ames Research Center, to this problem was discussed with Dr. Charles Lewis and Clint Johnson of the ARC. A test model of the spirometer is not available from ARC and is not commercially available. Arrangements were made for ARC to furnish detail construction drawings of the spirometer.

The unit has been received (Figure 17) and is being evaluated by the investigator. Initial results indicate the spirometer is not satisfactory for pulsatile flow. The investigator is now evaluating other possible clinical applications.

PROBLEM KU-42: Measurement of Body Vibrations

The investigator is attempting to assess human vibration sensitivity, both psychologically and physiologically. Vibrations of the environment of only a few thousandths of an inch in the frequency range 3 to 15 Hz cause psychological and physiological distress in the human being. Psychological, because the individual is either unaware of the vibration or unable to identify its source, and physiological, because the vibration effects the body's organs. Tests are to be performed on humans and experimental animals to determine where and how humans sense vibrations, and to discover how small vibrations affect humans psychologically. Acceleration levels will be 0.1 to 0.2 g's at several amplitudes and frequencies. Measurements will be made on various parts of the body, e.g., the head, the sternum, the extremities. In animals, acceleration of various internal organs will be measured.



Figure 16 - NASA Modified Wright Spirometer

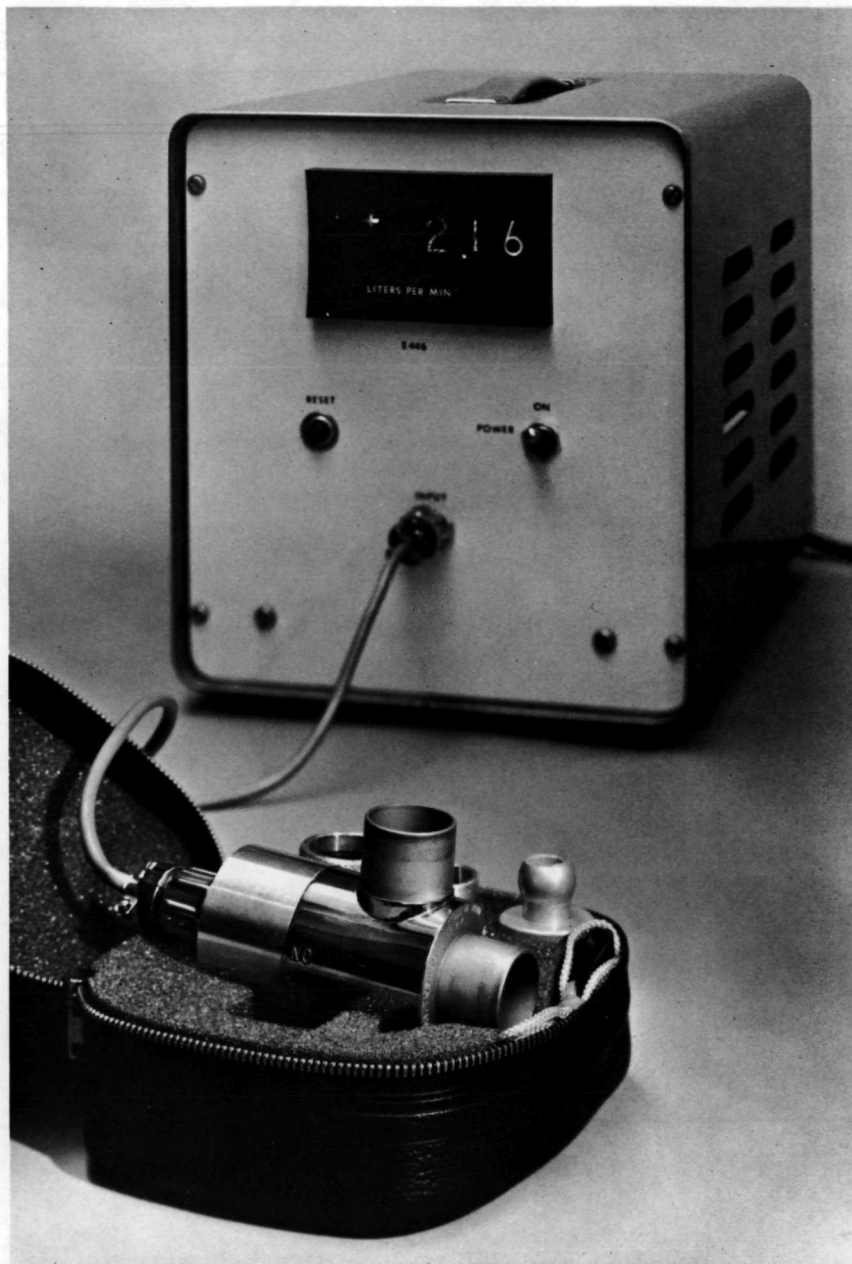

Figure 17 - Respirometer Flowmeter

A potential solution for this problem is a single axis accelerometer manufactured by Whittaker Corporation. (Formerly made by a section of Electro-Optical Systems, now combined with Whittaker Corporation.) The model BA1 piezoresistive accelerometer is similar to one element of the triaxial accelerometer described in NASA Tech Brief B66-10534 (Figure 18). The Ames Research Center contracted with Electro-Optical Systems, Inc., to design and construct the triaxial accelerometers using piezoresistive strain gages rather than the original piezoelectric elements. The change was made to improve low-frequency response.

The investigator ordered one triaxial accelerometer in June 1970. The unit is a special-order item and required about 4 months to obtain.

The accelerometer seems to be just what the investigator needs. It has the proper sensitivity, frequency response, and size characteristics. He has not obtained data because of difficulties in another aspect of the experimental setup.

PROBLEM MCGH-1: NMR Application to Cardiac Output Measurement

The phenomena of nuclear magnetic resonances offers a possible method for the noninvasive measurement of blood flow. Investigators at the Milwaukee School of Medicine are developing a flow meter based on this principle for use in cardiac care units (CCU).

An ARAC search was conducted and several documents (N69-15264, N69-18048, N70-23835, N68-24062) are providing the investigators with circuit information concerning the detection of small magnetic fields. Several circuit modifications are considered due to the additional data supplied to the investigator.

PROBLEM MCGH-2: Cortical Mapping of Visual System Projections

The investigator is studying the feasibility of a visual prosthesis through implantations of electrodes in the cortex.

An ARAC search has already provided him with five documents prepared by the NASA Space Biology Laboratory which are useful in localizing the stimulating electrodes in the visual area of monkeys. In particular, Ross Adey's Macaque Brain Atlas, compiled under a NASA contract, is being used as a working model for the animal experiments.

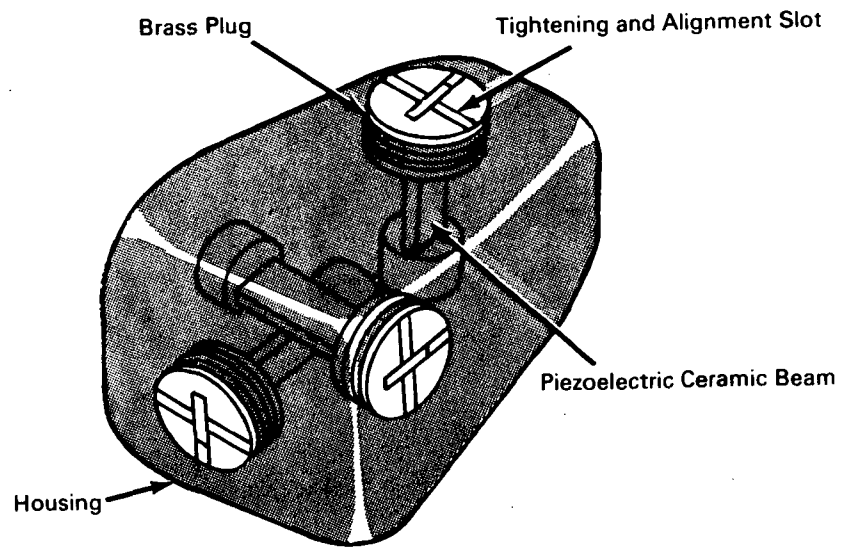

Figure 18 - Triaxial Piezoresistive Accelerometer

PROBLEM KCH-1: Computerized Medical Surveys

The investigators are obtaining in-patient data from 30 K. C. area hospitals for medical surveys. These data include addresses (which are computer address coded and can be geographically presented), diagnosis (using ICDA-International Classification of Diseases), and billing data. Data for approximately 150,000 patients will be gathered in a year. The investigators have the capabilities of graphically displaying these data in several forms (an example is shown in Figure 19), but cannot easily retrieve desired sets of information from their data tapes.

One of the investigators attended the MEDATA seminar at MRI. He believes that the MEDATA program will be very useful to his problem in the batch processing form. NASA document N68-27549 and MSC documentation on the program was supplied by the investigators. A magnetic tape listing of the source program has been obtained and supplied to the investigator.

PROBLEM IU-37: Encapsulation of Electronics

Presently, tiny telemetry systems are implanted in human and animal bodies to monitor vital physiological functions. Many of those implanted for long periods of time (over 1 year) have signal and electrical lead (conductor) seals exposed to corrosion by body fluids. Should the conductor seals fail, the telemetry system's battery electrolyte and structural components could poison the host. Moreover, the animal body fluids could do injury to the instrumentation. These hazards can best be circumvented by the use of improved lead seals.

As more electronic devices are becoming available for implantation in human patients to correct or monitor physiological functions, it is desirable that these devices last as long as possible before replacement is required. The investigator is convinced that the major cause of device deterioration and failure is the leakage of body fluids into the device by corrosion around the lead connections. The total prevention of leakage would help in the prediction of device life and to prevent unexpected device malfunction that in some cases, such as a heart pacemaker, could cause the death of the patient.

A manual search was made and several relevant documents sent to the investigator. His evaluation of these documents was, "Several documents were on very critical and very important information. One of them was called Biotelemetry Developments by Tom Fryer, another was Encapsulation Materials by Henry Lee et al., another was Encapsulation Procedure (N70-25502) by Charles Nichols. These abstracts are extremely important in our work."

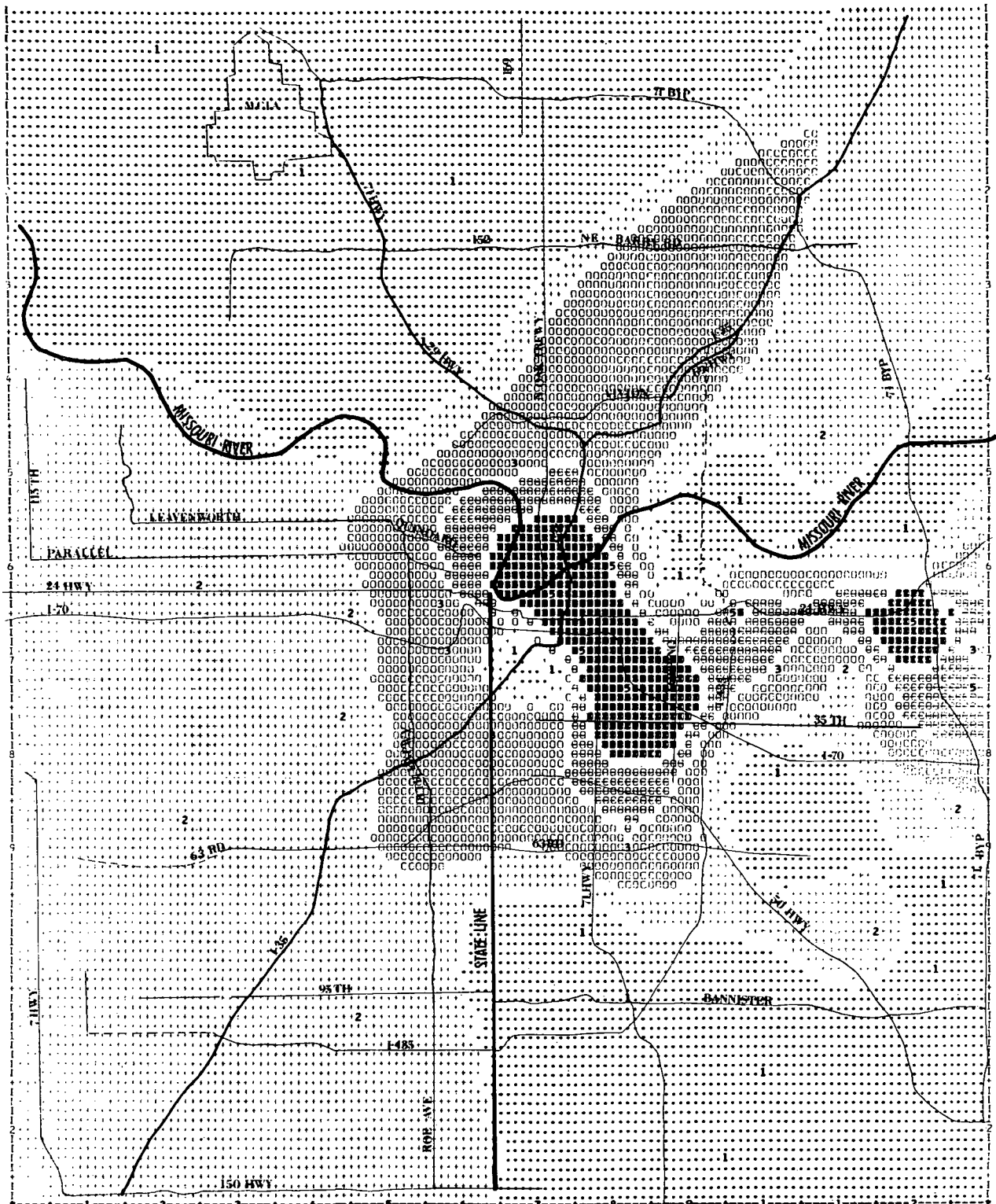

C PREPARED BY INFORMATION SYSTEMS DEVELOPMENT, INC.
 C 3430 BROADWAY - KANSAS CITY, MO. - PL3-4322

- C SULFATION RATE - 1967
- C ANNUAL ARITHMETIC MEAN MG SO3/100 CM2/OAY
- C PHS ABATEMENT ACTIVITY PHASE II

Figure 19 - Proposed Geographic Display of Medical Data

PROBLEM UM-140: Survival of Biological Cells in Vacuum

The investigator is studying cell membrane transport and wants to expose some cells to X-ray and electron beams as a way to make very small punctures in the membrane without damage to the rest of the cell. He would like to expose these cells in a vacuum and needs a cell or spore that can survive such an environment.

The investigator was sent Report N63-12213, and his evaluation was, "We learned through this report of at least one (and probably several) microorganisms that can withstand high vacuum. We plan to use these microorganisms in our research in which this property will be essential.

PROBLEM WU-3: Mechanical Stresses in Aortic Valves

It is desirable to fabricate an artificial aortic valve for a human heart which duplicates the mechanics of the normal valve. The normal aortic valve is composed of three leaflets which come together to close a circular opening. The leaflets are flexible and flap open and closed on each heart beat, nearly 40 million times/year. To design and evaluate a prosthetic tri-leaflet valve which can withstand many years of complex flexure, the dynamic stress-strain relationship must be known.

With the development of advanced fiber and composite material knowledge and technology through the National Aeronautics and Space Administration Programs and the advancements made in the blood-prosthetic surface interface research under the auspices of the Artificial Heart Program of the National Institutes of Health, the fundamental keystones have been laid for the development of a tri-leaflet prosthetic heart valve.

Use of close range stereophotogrammetry used by NASA will greatly aid the characterization of stress distribution and permit further explorations toward minimizing point stress.

It is anticipated that about 30 molds or 90 leaflets should be mapped to provide a statistical range of information. This work is to be performed on a consultation basis by Dr. H. M. Karara who has wide experience in this field. He has served as an advisor to Drs. Hugg, Herron, and Harrington in their study of idiopathic scoliosis which was sponsored by NASA and to Dr. Herron and Mr. Weissman in their use of stereophotogrammetry as a means of anthropometry for mentally handicapped children which was sponsored by the National Institute of Mental Health.

PROBLEM WMHC-1: Rapid Detection of Bacteria in Urine

The Wayne Miner Neighborhood Health Center provides health care to approximately 25,000 people in the inner-city of Kansas City, Missouri. One of its principal missions is to provide these persons with preventative medical care. One part of this mission consists of periodic visits by the staff to residences in the inner-city to measure blood pressure. Data accumulated by this program show a high incidence of hypertension among this population. Preliminary data from these hypertensive persons who consented to more thorough examination at the clinic suggested a high incidence of bacteriuria. As the result of this observation the Wayne Miner Clinic has been looking for a rapid means of making urinary bacteria counts in the field.

A potential solution to this problem was developed by Dr. Alan Fleig, Goddard Space Flight Center (Tech Brief 71-10055). This instrument can automatically count bacteria in urine samples within 5-15 min. This instrument has been tested at the Johns Hopkins Medical School with 5,000 urine samples, and was found to be more sensitive than conventional techniques.

A joint proposal between Wayne Miner Neighborhood Health Center and Midwest Research Institute has been prepared and funding is being sought.

PROBLEM UN-13: FM Telemetry

A small FM transmitter (nonimplantable) is needed for transmitting body temperature and heart rate. (Two separate transmitters may be used.) Range is 10-25 ft, carrier frequency 88-108 Mc. Physical size to be as small as possible, for small animal use.

A vital function study will be made of hibernating ground squirrels. A "cold box" will be used to house the animal and this box will be stored in a suitable refrigerated room. The animals will, of course, be inactive during hibernation and during this time the transmitter will be attached to the animal. Body temperature and heart rate information will be monitored during hibernation and during the period when the animal is waking.

The investigator was sent a copy of SP-5094 which describes transmitters that would be applicable.

NASA TECH BRIEF

Goddard Space Flight Center



NASA Tech Briefs announce new technology derived from the U.S. space program. They are issued to encourage commercial application. Tech Briefs are available on a subscription basis from the National Technical Information Service, Springfield, Virginia 22151. Requests for individual copies or questions relating to the Tech Brief program may be directed to the Technology Utilization Office, NASA, Code KT, Washington, D.C. 20546.

Automatic Bio-Sample Bacteria Detection System

An automatic electromechanical device dramatically reduces the time required for bio-sample analysis in the detection of bacteria. Bio-samples, such as urine specimens, can be analyzed in 15 minutes, and the instrument processes a sample a minute. Since urinary tract infections are indications of kidney or bladder disease or diabetes, and since the occurrence of such

With the device just developed, the time and skill required for such analyses are minimized, and, although the unit has only been built in prototype, it is conceivable that it could be made portable for non-laboratory use.

Basic research behind the system design concerned means of detecting microbiological life on other plan-

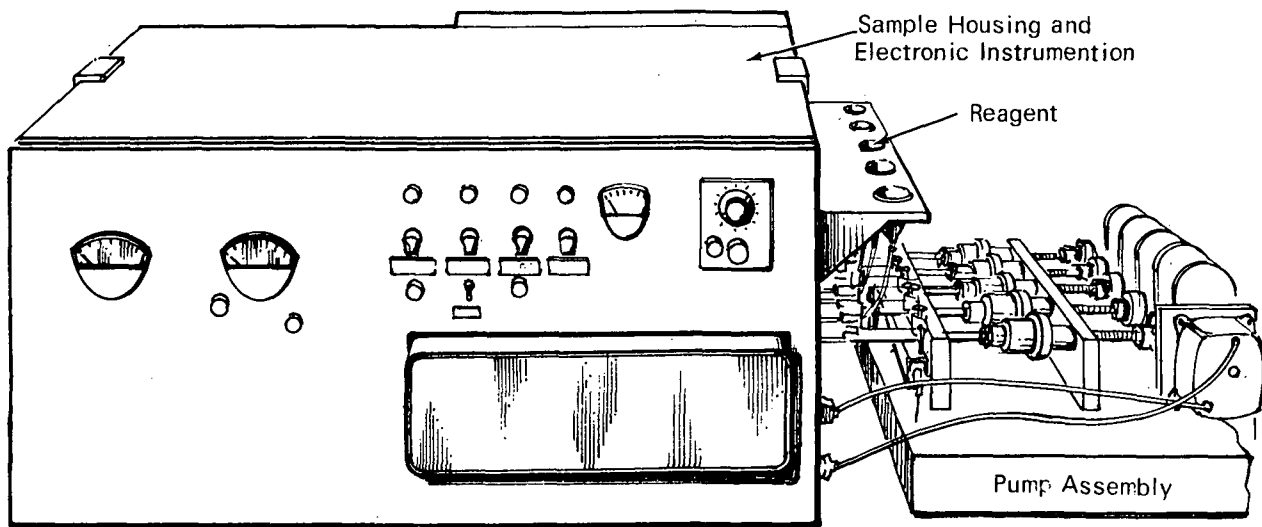

infections in the United States is second only to that of respiratory ailments, urinalysis is one of the most important and frequently conducted procedures in the clinical laboratory.

Present urinalysis techniques involve incubating the specimen with a nutrient for one or two days, and counting the visible number of bacterial colonies. This number provides an accurate index of the number of viable cells capable of dividing. However, considerable time is required to complete the analysis, and the process can only be performed in the laboratory by highly skilled microbiology technicians.

ets, using two chemicals—luciferase and luciferin—found in the common firefly. These chemicals produce a bioluminescent reaction when in contact with adenosine triphosphate (ATP), which is found in all living organisms. In urine samples, the concentration of bacterial ATP is directly proportional to the number of bacteria present in the sample.

In operation, the vials containing the urine samples are placed in openings in the periphery of the revolving table inside the light-tight housing. As the table turns, a series of spouts located at specific points around the table sequentially dispense chemical reagents into the

(continued overleaf)

vials to remove ATP from nonbacterial sources and release bacterial ATP. The amount of reagent dispensed by each spout is controlled by a pump system located outside the housing. At the final test point, a photomultiplier tube senses the light from the bioluminescent reaction in the urine when the luciferase-luciferin mixture is added. The output signal from this photomultiplier is directly proportional to the bacterial ATP concentration, which in turn is proportional to the number of bacteria present in the sample. When the reaction measurement is completed, the vials are ejected from the table.

The instrument has potential application to other physiological fluids, such as blood or spinal fluid; in tests where bacterial count is of immediate importance. It can also be used to detect and count bacteria in any fluid source containing living organisms, including water supplies.

Note:

Requests for further information may be directed to:

Technology Utilization Officer
Mail Code 207.1
Goddard Space Flight Center
Greenbelt, Maryland 20771
Reference: TSP71-10055

Patent status:

This invention is owned by NASA, and a patent application has been filed. Royalty-free nonexclusive licences for its commercial use will be granted by NASA. Inquiries concerning license rights should be made to:

Patent Counsel
Mail Code 204
Goddard Space Flight Center
Greenbelt, Maryland 20771

Source: Dr. Grace Lee Picciolo, Burton N. Kelbaugh,
Emmett W. Chappelle, and Maurice Colburn
Goddard Space Flight Center
(GSC-11169)

PROBLEM UN-14: Implantable Transmitter

Miniature FM ratio telemetry transmitter (88-108 Mc) is needed to transmit strain gage information. The size of the transmitter is critical; it must be as small as possible. It is to be implantable and is for human use.

The resistance change of the strain gage will be used to modulate the rf carrier of the transmitter. The transmitter will be the implantable type and needs to be very small. The size should not exceed 1/2 cu in. if possible. The range of the transmitter is noncritical; a self-contained antenna would be desirable.

The investigator was sent a copy of SP-5094 which describes transmitters that would be applicable.

PROBLEM MAKC-1: Emergency Medical Data Retrieval System

This organization is a lay voluntary organization founded by parents of children with meningomyelocele, spina bifida, hydrocephalus, and related birth defects. Recent surgical techniques have been developed which extend the life prospect of these children. However, with numerous surgeries (orthopedic, neurologic, and urologic), the records of these children come in several volumes. An organized set of basic medical data and a means of obtaining the desired data on quick-recall for emergencies (and most treatments are emergencies) is needed.

There are approximately 150 children in this association and 250-300 in the Greater Kansas City area.

The MEDATA computer program for the astronaut's medical records (MSC) appear to be an ideal solution to this problem. Additional information on MEDATA can be found in NASA document SP-5078. It offers a narrative approach with a flexible outline and the size limitation should not be a factor.

Parental and hospital authorization was obtained.

PROBLEM UM-141: Thermo-Osmosis

A model system is being constructed to verify that there is actually thermo-osmosis in biological systems. Thermo-osmosis means that if there is a temperature gradient across a biological membrane, then mass will be transferred across a membrane (for instance, water from the interior of a cell to the exterior of the cell). The model system is being constructed to test this theory. It will consist of two well-stretched chambers separated by a membrane that can be replaced. A known temperature gradient will then be created across the membrane. Information is needed on construction techniques for such cells.

Several documents were sent to the investigator and three were evaluated as follows:

- (1) "The Thermodynamic Properties of HCl-BaCl₂ Mixtures," by M. H. Lietzke and R. W. Stoughton, 5. Chemistry of Aqueous System. N67-19346

Brief Description of Technology: The publication which was sent is Chapter 5 from a book. The chapter is entitled, "The Chemistry of Aqueous Systems." It consists of a number of short articles contributed by a variety of authors.

The articles deal with the various aspects of the physical-chemical properties of aqueous systems. Of particular interest was a short article entitled, "Physical Chemistry of Polyelectrolyte Systems." Another was entitled "Osmotic Coefficients of Sea Salt Solutions" and a third was entitled, "Thermodynamic Properties of Sea Salt Solutions."

Evaluation of Technology: The work is competently done by investigators with a good reputation and it appears to be complete, although somewhat brief.

Plans for Use: "We hope to use the information contained in the articles for theoretical treatment of data from our isopiestic experiments."

- (2) "Ion and Water Transport Processes in Spinach Chloroplasts," by Richard A. Dilley, Charles F. Kettering Research Laboratory, Yellow Springs, Ohio 45387. N67-31766

Brief Description of Technology: This is a report of a fundamental investigation of cell membrane permeability. The author looked at the movement of water and of ions in a very simple cell system, the chloroplasts from spinach. He measured each movement under various conditions including simulation by light.

Evaluation of Technology: The work seems to be very good. It involves modern concepts and good techniques.

Plans for Use: "We are in the process of trying to formulate a model for membrane transport and I think that we shall use some of the concepts and much of the data in much of this report."

- (3) "Effects of X-Ray-Radiation in Hemic Cells," by G. Astaldi, The Blood Research Foundation Center. N63-18959

Brief Description of Technology: Dr. Astaldi investigated the osmotic fragility of blood cells and how osmotic fragility is increased by exposure to x-ray-radiation. He used a standard technique of hypertonic swelling.

Evaluation of Technology: The work was done well, but there were too few samples and there was no statistical analysis of the data.

Plans for Use: "This study made some interesting observations on differential radiosensitivity of normal erythrocytes, leukocytes, and lymphocytes. We shall look into the membrane permeability of these peripheral blood cells for the normal case and for the irradiated case."

PROBLEM UM-143: Detection of Bio-Generated Magnetic Fields

The objective of the investigation is to monitor the magnetic field variations generated by electrical cardiac activity. Magnetic measuring techniques do not require the attachment of electrodes to the body and thereby circumvent the problems associated with electrical grounding of patients and with electrochemical changes at the tissue-electrode interface producing artifactual signals. The graphic traces obtained with the magnetic method are expected to contain the same information as in electrocardiography (ECG).

Previous investigators have detected peak-to-peak magnetic fields on the order of 10^{-7} gauss associated with heart activity (e.g., Dr. David Cohen, Massachusetts Institute of Technology). Dr. Cohen's studies were performed in a heavily shielded room using either bulky multiturn coils or Josephson junction devices. The requirement for the shielded room and for cryogenic techniques in the case of the Josephson devices severely restricts application of magnetic monitoring techniques. The goal is to remove these impediments so that this technique can enjoy broader application.

Under a NASA contract, NAS 511173 entitled, "Magnetic Experiment for Small Scientific Satellite," Dr. Lawrence J. Cahill, Jr., Professor of Physics and Director of the Space Science Center at the University of Minnesota, has developed a magnetic probe for detecting low magnetic fields. The probe is comprised of a 42,000-turn search coil wound on a cylindrical rod housing a center core of poly-permalloy and of a low power, low noise, gain-stabilized preamplifier. The preamp is operated differentially to provide for rejection of common-mode power supply noise as well as ground and stray pick-up noise. Bias stability is achieved by providing dc feedback

proportional to stability by means of a series source resistor having magnitude proportional to feedback. The matched pairs of FET's require low power, have gain down to dc and have a high input impedance so that the individual stage input impedance and band-pass characteristics are dependent only on the design of the passive elements.

The probe was designed to detect magnetic fluctuations in the earth's field of 0.1γ to 1.0γ ($1 \gamma = 10^{-5}$ gauss) at 1 c/s following a $1/f$ relationship for frequencies up to 3 kc/s. The search coil with an output voltage proportional to f driven from a magnetic field proportional to $1/f$ will produce a constant voltage output over the frequency band of interest. The search coil determines the sensitivity and upper cut-off frequency with noise and gain characteristics of the amplifier determining the minimum signal detectable. A probe sensitivity of $4.5 \mu\text{V}/\gamma/\text{c/s}$ permitted detection of $10^{-3} \gamma$ fields at a frequency bandwidth of 3 kc/s. By decreasing the bandwidth to 15 c/s and increasing the coil turns by a factor of two, the reduced input noise combined with increased signal is expected to compensate for the reduced sensitivity achieved at the frequency of heart activity so that these 1 to 2 c/s fluctuations can be observed.

To eliminate the requirement for a shielded enclosure to operate the probe, two techniques will be employed: (1) narrow band operation; the probe has a frequency roll-off of 27 db/octave to give approximately 60 db rejection of 60 c/s interference, and (2) computer signal averaging techniques; measurement of the repetitively occurring cardiac activity in the presence of randomly occurring magnetic field variations, due perhaps to Barkhausen jumps, over several cycles eliminates the random signals having an average of zero. It appears from preliminary operation of these probes that ambient magnetic field variations will not be a significant problem if these techniques are employed. Operation of the coil and preamplifier does not require the use of cryogenic techniques and can be powered by batteries to permit portable utilization and to reduce power supply noise.

PROBLEM CRS-2: Audio Communicator

The use of "clean rooms" in the surgery suite and complete isolation garments for the personnel has made direct communication between the operating team difficult. A communication system is needed that will give direct voice communication and will not compromise the isolation capabilities of the protective clothing.

The audio transceiver described in Tech Brief 70-10335, appears to have application. Mr. Cribbs at KSC is interested in building prototype units to be evaluated under actual conditions. Dr. Bechtol has agreed to evaluate the unit.

NASA TECH BRIEF



NASA Tech Briefs announce new technology derived from the U.S. space program. They are issued to encourage commercial application. Tech Briefs are available on a subscription basis from the Clearinghouse for Federal Scientific and Technical Information, Springfield, Virginia 22151. Requests for individual copies or questions relating to the Tech Brief program may be directed to the Technology Utilization Division, NASA, Code UT, Washington, D.C. 20546.

Self-Contained Miniature Electronics Transceiver Provides Voice Communication in Hazardous Environment

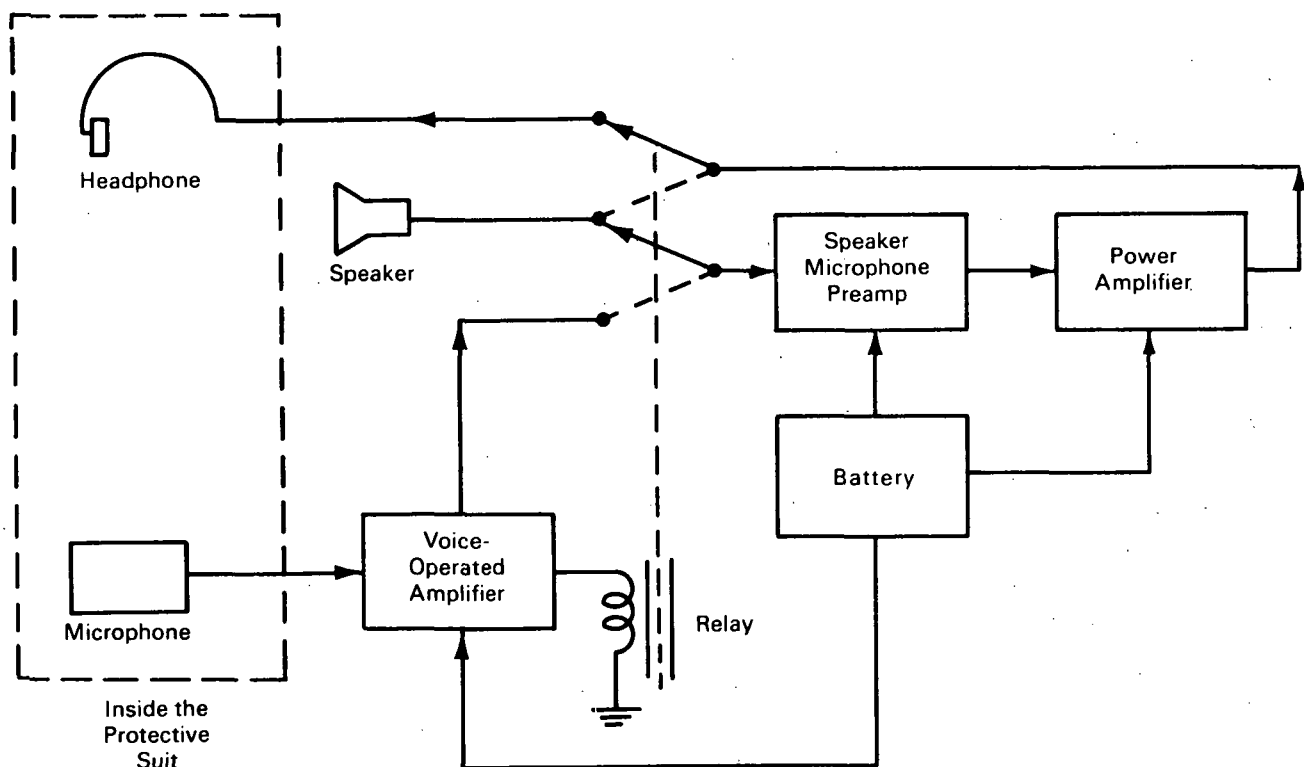

The problem:

A workman who handles corrosive substances and performs duties in a high-temperature environment requires protective clothing and a face mask. Voice communications between the workman and a central control station must be maintained to convey instructions and to provide a "psychological" sense of attachment to his fellow workers. The voice communications system must fulfill the following requirements: (1) the communications equipment must not impede

the freedom of movement of the worker, i.e., he must not be restricted by cables attached to his person; (2) operation of the system must be automatic—the voice of the worker provides the input energy to activate the system in the proper mode; (3) the worker must be able to maintain an acute awareness of his surroundings and must hear sounds which are advance warnings of impending hazards (hissings of gas, cracking of materials, voice warnings and the like); and (4) the communications system must not introduce an

(continued overleaf)

additional hazard, i.e., the rf output power must not activate electromagnetic sensitive devices such as fuses or explosives.

The solution:

A two-way wireless voice communications system has been developed that fulfills all of the requirements. It consists of a combination speaker-microphone unit and an electronics unit that hangs around the neck of the worker.

How it's done:

As shown in the block diagram, the user merely speaks into the microphone and his voice is transmitted, external to the protective suit, by the combination speaker and receiver. When he is not talking, the system is in the receive position so that he can hear noises above a particular audio level in the immediate vicinity. The voice-operated amplifier must be biased to a certain level to prevent activation by noises (inside the protective suit) such as the hissing of flowing air. The system is normally operated in a receive condition except when the user speaks. In the transmit mode the unit becomes a miniature audio amplifier with a power output of about one watt. In one par-

ticular application, users of the system were able to communicate (at normal voice level) at a distance of fifty feet.

Note:

Requests for further information may be directed to:
Technology Utilization Officer
Kennedy Space Center
Kennedy Space Center, Florida 32899
Reference: TSP 70-10335

Patent status:

This invention is owned by NASA, and a patent application has been filed. Royalty-free, nonexclusive licenses for its commercial use will be granted by NASA. Inquiries concerning license rights should be made to NASA, Code GP, Washington, D. C. 20546.

Source: Herbert E. Cribb
Kennedy Space Center
(KSC-10164)

THE UNIVERSITY OF CHICAGO



THE UNIVERSITY OF CHICAGO
DIVISION OF THE PHYSICAL SCIENCES
DEPARTMENT OF CHEMISTRY
5708 SOUTH CAMPUS DRIVE
CHICAGO, ILLINOIS 60637

RESEARCH REPORT

REPORT NO. 1000
TITLE: [Illegible]

AUTHOR: [Illegible]

DATE: [Illegible]

ABSTRACT: [Illegible]

INTRODUCTION: [Illegible]

EXPERIMENTAL: [Illegible]

RESULTS: [Illegible]

DISCUSSION: [Illegible]

CONCLUSIONS: [Illegible]

REFERENCES: [Illegible]

ACKNOWLEDGMENTS: [Illegible]

FOOTNOTES: [Illegible]

APPENDICES: [Illegible]

INDEX: [Illegible]

TABLES: [Illegible]

FIGURES: [Illegible]

REVISIONS: [Illegible]

REVISION NO. 1

D. Impacts

The primary objective of the Biomedical Application Team is to solve biomedical problems with NASA technology. However, in the course of their interactions with problem originators, several solutions were found to be the culmination of NASA technology, commercial technology, and the team members' own ingenuity. Although the technology transferred was not readily identifiable with NASA, the recipient was cognizant that NASA made the solution available to him.

This, in turn, creates a very healthy atmosphere for future utilization of NASA technology. The following paragraphs describe impacts occurring during the report period.

Visit to United Methodist Hospital of Indiana, Inc.: The United Methodist Hospital of Indiana in Indianapolis, Indiana, was building a clean operating room with vertical laminar flow for orthopedic surgery.

Their initial experience in planning this facility was with a commercial firm who proposed plans that were financially unsuitable to the hospital.

As an alternative, the hospital's chief engineer, Mr. Ray Allen, began to consider the possibility of using a local contractor to build the operating room. Soon after, our Biomedical Application Team received a request from them for available NASA/AEC specifications on clean rooms. We supplied Mr. Allen with the requested information, after which he invited the BA Team to visit their facilities and review their plan.

Mr. Don Roberson and Dr. Tom Castles visited Mr. Ray Allen as requested. Recommendations included relocation of the scrub room and the addition of a restricted operating room entry with a "clean" air shower. Upon finding that this operating room was to be a pilot facility and would be moved in 1-2 years, they suggested several portable features (e.g., sectioned inner walls) be included in their plans. They also suggested that Mr. Allen visit Barnes Hospital in St. Louis and discuss clean operating rooms with Dr. Richard E. Clark (Problem WU-5).

Subsequently, Mr. Allen and Dr. Edwards visited Dr. Clark and his facilities. This meeting, NASA/AEC information, and the BA Team visit were apparently beneficial to the Indiana group (see Figure 20).

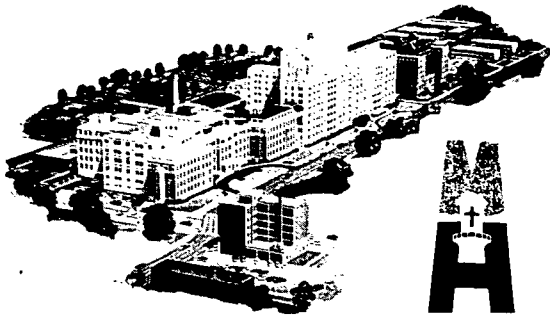

METHODIST HOSPITAL
OF INDIANA, INC.

December 8, 1970

Dr. Thomas Castle
Midwest Research Institute
425 Volker Boulevard
Kansas City, Missouri 64110

Dear Doctor Castle:

We wish to take this opportunity to thank you for your visit last week to Methodist Hospital and express our appreciation for the advice and counseling given to us with regards to our Laminar Linear Air Flow Surgical Suite.

Your suggestion and Mr. Don Roberson were of a measurable value and we shall incorporate them within the design of this surgical suite. As you are aware, we were not knowledgeable in this field and were having trouble finding proper advice. Thanks to you and Mr. Roberson we feel that we may proceed ahead towards a better design and also at a lower cost which was very gratifying.

Again, thank you very much for your cooperation and attention in this matter.

Very truly yours,

Ray Allen
Director of Facilities Planning
and Engineering

Jack A. L. Hahn
President
Methodist Hospital of Indiana

RA:rf

MEDATA seminar: Several Kansas City hospitals are seriously considering the computerization of their medical records.

Last year, SwRI sponsored a seminar at Manned Spacecraft Center (MSC) to introduce the BA Teams to the medical records system (MEDATA) used for the astronauts. Through this seminar, we became familiar with the MEDATA system and its originator, Dr. Tate Minckler. From a recent contact with Dr. Minckler, we learned that he was transforming MEDATA from the "batch mode" to the "time share mode" so that it would be more adaptable to hospital use. By January 1971, Dr. Minckler had his modified MEDATA system working on a limited fashion through United Computing Systems, Inc., of Kansas City. In light of the situation in Kansas City hospitals, it seemed appropriate to sponsor a seminar designed to critically evaluate computerization of medical records and to demonstrate the modified MEDATA system.

Arrangements were made with Dr. Minckler to present this seminar and invitations were extended to hospitals in the Kansas City area. Selected groups outside the area who had indicated interest were also invited. The following groups were represented.

Biomedical Computers, Inc. Minneapolis, Minnesota	Kansas Regional Medical Program Kansas City, Kansas
Stanford Research Institute Palo Alto, California	Information Systems Development, Inc. Kansas City, Missouri
University of Missouri Columbia, Missouri	St. Mary's Hospital Kansas City, Missouri
General Electric Kansas City, Missouri	Shawnee Mission Hospital Shawnee Mission, Kansas
St. Joseph Hospital Kansas City, Missouri	Kansas City Health Department Kansas City, Missouri
Independence Hospital Independence, Missouri	Menorah Hospital Kansas City, Missouri
Trinity Lutheran Hospital Kansas City, Missouri	Kansas City General Hospital Kansas City, Missouri
Wayne Miner Court Kansas City, Missouri	Kansas City Osteopathic Hospital Kansas City, Missouri
Providence Hospital Kansas City, Kansas	Midwest Research Institute Kansas City, Missouri

The seminar was presented in two parts. First, Dr. Minckler presented the "batch mode" MEDATA system used at MSC. He emphasized the necessity of a standardized record system before computerization is considered. In addition, several examples were shown to explain why the English language (instead of codes) and free-form descriptions of symptoms were important elements of MEDATA.

Following Dr. Minckler's description of the MEDATA system used at MSC, he described his modification of the MEDATA system. Briefly, this system has the same data entry format, but is used on a completely different computer system.

The major advantage of Dr. Minckler's system was the use of a direct access computer terminal. Presently, the major disadvantage is the large storage requirement.

The second phase of Dr. Minckler's seminar was a demonstration of the "time sharing" MEDATA system on a terminal supplied by United Computing Systems, Inc., of Kansas City. This demonstration included examples of the communication mode, data retrieval, and simple statistical presentation of the data.

This seminar produced two very visible results. First, several Kansas City hospitals are now aware of the inherent problems to medical record keeping and are following the progress of Dr. Minckler's system. Second, one of the attendees is currently working with the MSC version of MEDATA to utilize its retrieval capacity for the preparation of medical surveys. This organization is currently performing these services for the local Blue Cross-Blue Shield, Kansas City Health Department, and local hospital associates.

Interaction with Ames Research Center: C. K. Doll visited Dr. H. P. Klein at the Life Sciences Research Laboratory. A meeting was arranged by Dr. Klein with representatives from Biomedical Research, Biotechnology, Human Performance, Electronics Research, Research Instrumentation, Operations, Man-Machine Integration, and Environmental Control in which all the active MRI problems were reviewed. The result of this meeting was that on 34 of the problems, relevant work was being done at Ames and the names of 22 scientists and investigators directly involved in this work were obtained for later contacts and follow-up. Eight of the Ames investigators were visited and specific problems discussed.

The information that was obtained was distributed and two investigators have requested assistance in contacting the investigators at the Ames Magnetics Laboratory. The investigators are working on Problem UM-49, "Hand Movement," and UM-119, "Magnetic Impulse Detection." These investigators are now corresponding with the Ames Research scientists.

AAGP meeting: In May 1970, Mr. James T. Richards, NASA Headquarters, and Dr. Thomas R. Castles and Mr. John E. Stacy, MRI, met with the Medical Technological Development Committee of the American Academy of General Practitioners at the Marriott Motel in Chicago. Discussion was focused on ways by which NASA could help the general practitioner extend his health care delivery.

Briefly, NASA's offer to help the AAGP has been well received by the National Assembly of Delegates and action has been initiated to identify ways by which NASA can interact with the AAGP (see Figure 21).

Transfer of non-NASA technology: A transfer of non-NASA technology (A70-15361) was accomplished as a partial solution to Problem UW-26 (Microbiological Cell Measuring Techniques) at the University of Wisconsin. A letter from the investigator is shown in Figure 22.

Information transfer: Problem UN-11 from the University of Nebraska dealing with electrical leakage and safety in monitoring biomedical parameters has been processed and the ARAC search evaluated with little hope of finding any useful information. The technologist was familiar with the H/P Safety Bulletin, however, and this was sent to the investigator. He found the bulletin very useful and will be using it in his classes. A copy of the evaluation of the bulletin is shown in Figure 23.

Information transfer: An ARAC search on Problem UW-58, Light Detectors, produced document A70-10419. The investigator is using the information in student education and for establishing design parameters for instrumentation now under construction on his problem. A copy of the evaluation is shown in Figure 24.

Information transfer: A search was made to locate low surface energy materials that could possibly be used for VA shunts (Problem UM-58, Low Surface Energy Materials). A Government report was located on Project THROMBUS that described such materials. The investigator has engaged an engineering firm to design shunts of these materials. The BA Team put the investigators in contact with suppliers of the materials and he expects to make several of these shunts for implants in experimental animals. In a letter from him, he stated, "The information is being used in a possible solution to the problem but as yet, we do not have a definite working model." Although the supplied document was Government, it was not directly sponsored by NASA--it was located through the BA Team effort.

NASA TECHNOLOGY AND APPLICATION PROGRAM

Thomas R. Castles, Director of the Biomedical Application Team of Midwest Research Institute in Kansas City, Missouri, had met with members of the headquarters staff to explore methods of cooperation between the Academy and Midwest Research Institute. Dr. Castles and Mr. Jack Stacy of MRI and Mr. James Richards of the National Aeronautics and Space Administration met with the committee to discuss areas of interest. NASA is charged with making the technology it has developed available to the general public. The MRI Biomedical Application Team was established to bring about additional uses of the knowledge gained by NASA. Basically, the MRI Team would like the Academy to list and describe problems in medical practice to which the NASA technology could be applied. It was pointed out that NASA would like to spend some of its resources on problems that will have an impact on improving the delivery of health care.

The committee believes that the proposed workshop on computer systems would serve as a means of identifying problems that could be submitted to the MRI Biomedical Application Team for study.

The committee plans to carry out its project of a workshop and to continue its liaison with the MRI Biomedical Application Team.

Figure 21 - Section in Medical Technological Development Committee,
--1970-1971 Report--

The University of Wisconsin



INSTRUMENTATION SYSTEMS CENTER

1500 JOHNSON DRIVE
MADISON, WISCONSIN 53706

AREA CODE: 608
TELEPHONE: 263-1552

August 13, 1970

Midwest Research Institute
425 Volker Blvd.
Kansas City, Missouri 64110

Attention: Ralph Fritz

Dear Mr. Fritz:

Thank you for your continuing efforts.

As you are aware I am involved in many projects with different biomedical researchers on the Madison campus. Thus the references and information you supply may be used with projects different from the original problem description. I will attempt to keep you informed of such indirect applications of your service. Considerable delay in the utilization of the supplied information is often unavoidable since new sources of funding must be found to apply the technology.

Let me also confirm my verbal report that supplied information is being utilized for educational purposes. The article "Instrumentation for Automated Examinations of Cellular Specimens" by Louis A. Kamensky and Myron R. Melamed reprinted from the Proceedings of the IEEE 57:2007, 1969 and supplied from your office is being distributed as educational material to sixty persons per year who attend the "Biomedical Instrumentation" short courses at the University of Wisconsin. In addition to describing an operational instrumentation technique the article describes instrumentation requirements and some advantages and disadvantages of different principles.

Enclosed is a new problem and some evaluation sheets.

Sincerely,

Kenneth C. Mylrea
Biomedical Instrumentation Group

KCM:saq
encl.

Figure 22 - Evaluation of Information Transfer at the
University of Wisconsin

EVALUATION OF TECHNOLOGY FOR
SPECIFIC MEDICAL PROBLEM

Medical Problem Title and Number:

UN-11

Reference (title, author, number, etc.):

H/P Safety Bulletin

Brief Description of Technology:

Evaluation of Technology:

Excellent for teaching electrical safety.

Plans for Use:

Will use in ICU classes on safety (have ordered 25 copies).

Name and Organization of Evaluator:

University of Nebraska

Date: Oct. 28, 1970

Please return to:

Biomedical Applications Team
Midwest Research Institute
425 Volker Boulevard
Kansas City, Missouri 64110

Figure 23 - Safety Bulletin Evaluation

EVALUATION OF TECHNOLOGY FOR
SPECIFIC MEDICAL PROBLEM

Medical Problem Title and Number:

UW-58, Light Detectors

Reference (title, author, number, etc.):

A70-10419, "Fiber Optics--Theory and Applications."

Brief Description of Technology:

Evaluation of Technology:

The information will be useful in designing fiber optic systems for use in the above connected problems.

Plans for Use:

The information is being used for student education and for establishing design parameters for instrumentation now under construction.

Name and Organization of Evaluator:

University of Wisconsin

Date: Oct. 6, 1970

Please return to:

Biomedical Applications Team
Midwest Research Institute
425 Volker Boulevard
Kansas City, Missouri 64110

Figure 24 - Fiber Optics Document Evaluation

Information transfer: Problem WU-23 requires a low-cost respiration monitor for use on premature infants. No NASA technology was found that would be readily useful, although a number of documents on impedance pneumography were forwarded to the problem originator. A commercial impedance bridge manufactured by Biocom, however, is a solution. It is inexpensive and will permit respiratory signals to be transduced from electrodes used for ECG. A spec sheet was forwarded by the BA Team and the problem originator stated that a unit will be ordered. Persual of the aerospace documents probably influenced the problem originator in the selection of the impedance method, but commercial equipment was utilized.

UM-94: The investigator that submitted Problem UM-94, "Prolonged Weightlessness During Bed Rest," has left the University of Minnesota and gone to the Chedoke-McMaster Centre in Hamilton, Ontario, Canada. The data that were furnished him are being used in establishing a new medical school. His statement about the data was,

"The several articles which we have received concerning the effects of weightlessness and bed rest have been evaluated. Since we are establishing a new Medical School and Research Facility with a large commitment to chronic disease, these have been invaluable. At the present time we are establishing Experimental Protocol to test the effect of prolonged bed rest in the rehabilitation patient. Within the next year we hope to have these studies underway."

Information transfer: A computer search that was run for Problem UM-90 was forwarded to a potential problem investigator at the University of Kansas Medical Center for evaluation and possible application. The search was used by a graduate student in dietetics and nutrition in preparing a report on problems in meeting nutritional needs of space travelers and evaluated as "very helpful."

Semi-automatic blood pressure monitor: The problem originator practices medicine in the ghetto areas of Kansas City, where the incidence of high blood pressure is 10 times greater than in the suburbs. For the early detection of this condition, volunteers are sent, door to door, to measure blood pressures. When abnormally high blood pressure is detected, the physician or a member of his staff must then relocate the patient for further tests and possible treatment. Understandably, if the blood pressure measurement is in error, much time has been wasted. Errors in blood pressure measurements have occurred too frequently; attributed primarily to the inability of volunteers to recognize pulse sounds and position the stethoscope. Thus, the problem originator needed a semiautomatic device which would give reproducible results regardless of the volunteer.

A search of NASA literature did not yield devices relevant to the problem; however, such a device was found commercially. The device is a "SphygmoStat Electronic Blood Pressure Monitor" (Model B-650), produced by Technical Resources, Inc., of Waltham, Massachusetts. It eliminates the need for a stethoscope, gives a visual display of the blood pressure, and costs \$150.

Information transfer: An investigator from ComGeneral Corporation, Dayton, Ohio, submitted a problem request earlier this year on tactile sensors. He believed that NASA might have developed devices in training primates or investigating communications techniques during space operations. ComGeneral was pursuing developments of their own design for indicating commands to a human subject. A search was made for the investigator. Twenty documents provided the investigator with design data and background information for use in investigation of tactile sensors and test procedures. A letter from the investigator is shown in Figure 25.

Information transfer: An investigator from the Rehabilitation Institute of Chicago requested NASA information and BA Team assistance with his studies of the genesis and resolution of decubitus ulcers in paralysis patients. His group is interested in the blood flow in dependent areas of the body vulnerable to pressure sores and would like to measure wide areas of skin temperature utilizing thermography. A manual search was performed and 10 relevant documents sent to the investigator. He evaluated these documents as "they have been and will be useful" and "excellent for decubitus ulcer screening and detection."

Clean room symposium: The symposium entitled, "The Application of Clean Room Technology to Surgery Suites," was held at the J. F. Kennedy Space Center on 21 and 22 May 1971. The total attendance was 71 persons, which included surgeons (orthopedic, cardiothoracic, and general), engineers (from industry, universities, hospitals, NIH, and NASA), administrators (from hospitals and NASA), operating room nurses, company representatives from leading clean room manufacturers and representatives from two medical journals.

The objectives of the symposium were to:

- Critically evaluate present applications of clean room technology in surgery.

- Place clean room technology in the proper perspective in the total surgery picture.
- Formulate positive action whereby the TU program can utilize NASA technology to assist the application of clean room technology to medicine.

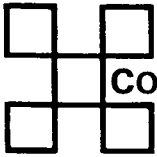

COMGENERAL CORPORATION □ 4518 TAYLORSVILLE ROAD □ DAYTON, OHIO 45424 □ 513/236-3591

May 25, 1971

Christine Guenther
Biomedical Applications Team
Midwest Research Institute
425 Volker Boulevard
Kansas City, Missouri 64110

Dear Miss Guenther:

The literature you have provided has given us a good understanding of the previous work in the field of tactile sensors. We are now in the process of experimenting with our own scheme and have every indication we will be able to perform the task initially outlined for this effort. Your assistance has saved us a great deal of time and experimentation.

We are appreciative of your continued assistance and grateful for your interest and consideration.

Sincerely,

Donald L. Roettele
President

Figure 25 - Tactile Sensors Literature Evaluation

The symposium was punctual and to the point. Those attending responded with many relevant problems. A copy of the program is shown in Figure 26.

In conclusion, the symposium achieved all objectives. Everyone, including clean room manufacturers, critically evaluated the current application of clean room technology to surgery and concluded that clean room procedures and instrumentation are an important adjunct in surgical procedures where infection cannot be controlled by ordinary means. Although, most attendees were aware that there is little factual data on the effectiveness of laminar flow clean rooms, few knew why. The symposium "highlighted" several reasons for this lack of data and led to the fulfillment of the third objective. Those attending agreed that a standard format for evaluating the use of clean room technology in surgery must be prepared. This document must: (1) recognize the limitations of current technology for performing the "ideal" comparisons; and (2) design a format general enough to be adaptable, but specific enough to provide the data base and stimulus for the development of new technology.

To prepare this document, the NASA modification of Federal Standard 209a will be used as a starting point. Several participants have agreed to serve as an ad hoc group to help prepare this document and test its applicability.

Another symposium is scheduled for 13 November in San Francisco. It is sponsored by Ames and St. Mary's Hospital. This symposium is a direct outgrowth of the MRI Kennedy Space Center meeting. It is being arranged by one of the KSC meeting attendees, is using several of the KSC meeting speakers and MRI assisted in the development of the program. A copy of the meeting announcement is shown in Figure 27.

The proceedings of the Symposium on Clean Room Technology in Surgery Suites were published in November. Copies were sent to all attendees and others who requested copies. The proceedings will be given to all attendees at future workshops on orthopedic surgery at the Cleveland Clinic.

The cover, title page, forward, and table of contents of the proceedings are included in this section.

One of the papers from the symposium was reprinted in the September/October 1971 issue of Contamination Control magazine. Editorial comments from this issue, which mention the meeting at KSC, and the initial page of Dr. Bechtol's article are included in this section.

A summary of the entire meeting is being published in a two part series in Hospital Topics magazine (Vol. 49, Nos. 10 and 11).

THURSDAY, 20 May 1971

Afternoon

5:00 - 10:00 Registration at Holiday Inn
COCOA BEACH, FLORIDA

FRIDAY, 21 May 1971

Morning

7:30 - 8:30 Registration continues at Holiday Inn

8:30 Buses loading at motel

9:30 Morning sessions

Welcoming Remarks

--for NASA Office of Technology Utilization - James T. Richards, Jr., Chief, Technology Applications Division, NASA Headquarters

--for J. F. Kennedy Space Center - General D. F. Callahan, L.L.D., Deputy Director, Administration

9:45 Introductory Remarks - H. D. Sivinski, Manager of Planetary Quarantine Department, Sandia Laboratories, Albuquerque (Moderator)

10:00 Microbiology of Surgery Suites - J. A. Ulrich, Ph.D., Chief Microbiology Section, Bernalillo County Medical Center, Albuquerque

10:45 Coffee break

11:15 Principles of Laminar Air Flow Systems - W. J. Whitfield, D.Sc., Sandia Laboratories, Albuquerque

12:00 Lunch

Afternoon

1:30 Use of Total Horizontal Laminar Flow Systems in Surgery - J. P. Nelson, M.D., Orthopedic Surgeon, Denver.

2:00 Use of Total Vertical Laminar Flow Systems in Surgery - C. O. Bechtol, M.D., Orthopedic Surgeon, Los Angeles

Figure 26 - Program for the Clean Room Symposium at KSC

2:30 Use of a Vertical Laminar Flow System over the Operating Field - R. E. Clark, M.D., Cardiothoracic Surgeon, St. Louis

3:00 Coffee break

3:30 Experience with a Wall-Less Horizontal Clean-Air System - C. L. Nelson, M.D., Orthopedic Surgeon, Cleveland

4:00 Improving the Air Environment of the Operating Room - H. Buchberg, Professor

4:45 Buses to motel

7:00 Cocktail hour (cash bar) - Holiday Inn

8:00 Banquet - Holiday Inn
Speaker - A. C. Harter, M.D., Chief of Medical Services for Kennedy Space Center

Topic: "Biomedical Experiments for Sky Lab"

SATURDAY, 22 May 1971

Morning

8:30 Buses load at motel

9:30 Asepsis and the Operating Room - H. C. Amstutz, M.D.

10:00 New Hips for Old: Total Prosthesis Replacement - I. S. Leinbach, M.D.

10:30 Forum on the application of a clean room technology to surgery suites. Problems and potential solutions will be discussed. Panel members will include:

H. D. Sivinski (Moderator)	I. S. Leinbach, M.D.
J. A. Ulrich, Ph.D.	A. C. Harter, M.D.
W. J. Whitfield, D.Sc.	H. Buchberg, Ph.D.
H. C. Amstutz, M.D.	R. C. Marsh

11:45 Closing Remarks

12:00 Lunch

1:30 Tour of Kennedy Space Center for attendees. Transportation will be available for those who cannot stay for the tour.

4:30 Arrive at motel

Figure 26 (Concluded)

Symposium —

"THE BIO-CLEAN ROOM AND ITS APPLICATION TO SURGICAL SUITES"

Friday & Saturday
November 12 & 13, 1971

St. Mary's Hospital &
Medical Center
San Francisco, California

SPONSORED BY:

SAN FRANCISCO
ORTHOPAEDIC TRAINING PROGRAM

NATIONAL AERONAUTICS
AND SPACE ADMINISTRATION
(AMES RESEARCH CENTER)

The symposium is designed to cover in depth the concept of Laminar Flow Air (Unidirectional Air Flow) and H.E.P.A. Filtration as they are used in Clean Room Technology. The use of alternate principles in the control of the operating room environment will be discussed. The current ideas on etiology, morphology and prognosis of operative wound infections will be presented. Special emphasis will be placed on the morbidity of wound infections seen in Total Hip Replacement Surgery. The bacteriologic effectiveness of the current commercially available Laminar Air Flow Systems will be presented. Medical Legal implications of the Bio-Clean Room will also be discussed.

PROGRAM

FRIDAY — NOVEMBER 12

REGISTRATION (8:00 A.M.)

INTRODUCTION AND WELCOME (8:45 A.M.)

Captain Walter Goldenwrath, M.S.C.
Special Assistant to the Director of Life Science
N.A.S.A. — Ames Research Center

Lloyd W. Taylor, M.D.

Director

San Francisco Orthopaedic Training Program
San Francisco, California

MODERATOR

Richard B. Welch, M.D.

San Francisco Orthopaedic Training Program
San Francisco, California

THE COMPLEXITY OF THE OPERATIVE WOUND INFECTION

Thomas K. Hunt, M.D. — Associate Professor, General Surgery, University of California Medical School, San Francisco, California

THE MICROBIOLOGY OF THE SKIN

J. A. Ulrich, Ph.D. — Professor of Microbiology and Pathology, University of New Mexico Medical School, Albuquerque, New Mexico

BASIC PRINCIPLES OF LAMINAR FLOW SYSTEMS

Willis J. Whitfield, D.S.C. — Division Supervisor, Applied Science Division, Sandia Laboratories, Albuquerque, New Mexico

METHODS OF LIFE DETECTION FOR PLANETARY EXPLORATION, PROSPECTUS FOR TERRESTRIAL APPLICATION TO MONITORING MICRO-ORGANISMS

Vance Oyama — Chief, Life Detection Branch, N.A.S.A., Ames Research Center, California

PUBLIC HEALTH CONSTRUCTION REGULATIONS CONTROLLING LAMINAR AIR FLOW MODIFICATIONS IN SURGICAL SUITES

Keith Sellars — Bureau of Health Facilities, Planning and Construction, California Public Health Department, Los Angeles, California

LUNCH

ST. MARY'S HOSPITAL & MEDICAL CENTER

PROGRAM continued

Figure 27 - Program for the Clean Room Symposium in San Francisco

PROGRAM — FRIDAY continued

MODERATOR

Richard Maurer, M.D.
Assistant Professor of Orthopaedic Surgery
University of California Medical School
San Francisco, California

THE WALL-LESS LAMINER FLOW CLEAN AIR SYSTEM FOR HOSPITAL OPERATING ROOMS

Boyd Agnew — President, Agnew-Higgins, Inc., Garden Grove, California

TURBULENCE AS A FACTOR IN THE BIO-CLEAN SURGICAL MODULE

Milton E. Gray — Consultant Engineer to the Richard's Manufacturing Company, Memphis, Tennessee

ENGINEERING CONCEPTS RELATIVE TO ATTAINING LAMINER FLOW IN SURGICAL SUITES

Robert E. Foreman — President, Sterilair, Santa Ana, California

THE ALLANDER AND CHARNLEY AIR SYSTEMS IN THE MODERN OPERATING ROOM

Frank Knight — Director of Engineering, Codman and Shurtleff, Randolph, Massachusetts

PHYSICS OF AIRBORNE PARTICLE CONTROL WITH SPECIAL REFERENCE TO SURGICAL CLEAN ROOMS

R. Claude Marsh — Director of Research and Development, Envirco Division of Becton Dickinson and Company, Albuquerque, New Mexico

TURBULENCE SYSTEM FOR RECIRCULATION OF AIR IN OPERATING ROOMS

J. A. Ulrich, Ph.D. — Professor of Microbiology and Pathology, University of New Mexico Medical School, Albuquerque, New Mexico

SCIENTIFIC AND BUSINESS DINNER MEETING
NORTHERN CALIFORNIA CHAPTER
WESTERN ORTHOPAEDIC ASSOCIATION
CHILDREN'S HOSPITAL — SAN FRANCISCO, CALIF.

SATURDAY — NOVEMBER 13

COMBINED ORTHOPAEDIC SURGICAL ROUNDS
(8:00 A.M.)

San Francisco Orthopaedic Training Program
University of California Orthopaedic Department
ST. MARY'S HOSPITAL & MEDICAL CENTER

P.R.O.G.R.A.M. — SATURDAY continued

MODERATOR

Lloyd W. Taylor, M.D.
Director
San Francisco Orthopaedic Training Program
San Francisco, California

THE STANDARD SURGICAL SUITE AND IMPLANT SURGERY

Richard B. Welch, M.D. — San Francisco Orthopaedic Training Program, San Francisco, California

THE FUNCTIONAL & TECHNOLOGIC EVALUATION OF THE HORIZONTAL WALL-LESS BIO-CLEAN ROOM

Merrill Ritter, M.D. — Assistant Professor, Department of Orthopaedic Surgery, Indiana University, Indianapolis, Indiana

EXPERIENCE WITH HORIZONTAL FLOW OPERATING ROOM CLEAN ROOMS

J. Phillip Nelson, M.D. — Active Staff Orthopaedic Surgery, St. Luke's Hospital, Denver, Colorado

THE VERTICAL FLOW BIO-CLEAN ROOM

Charles G. Hutter, M.D. — Active Staff Orthopaedic Surgery, Hollywood Presbyterian Hospital, Hollywood, Calif.

MEDICAL LEGAL TRENDS IN MALPRACTICE

Robert D. Huber, J.D. — Hazzard, Bonnington, Rogers and Huber, Legal Counsel to California Medical Association, San Francisco Medical Society and American Mutual Insurance Company

REGISTRATION

Registration limited to 225.

For Advance Registration complete registration form and forward with tuition to the Course Chairman.

For Housing contact the Hilton Hotel situated at Mason and O'Farrell Streets, San Francisco, California 94102

Telephone: (415) 771-1400

For your convenience, use attached reservation form.

Tuition includes luncheon at St. Mary's Hospital and dinner at the Northern California Chapter Meeting of the Western Orthopaedic Association at Children's Hospital, San Francisco.

PHYSICIANS \$ 50.00
OTHERS \$ 50.00

SYMPOSIUM ON CLEAN ROOM TECHNOLOGY IN SURGERY SUITES

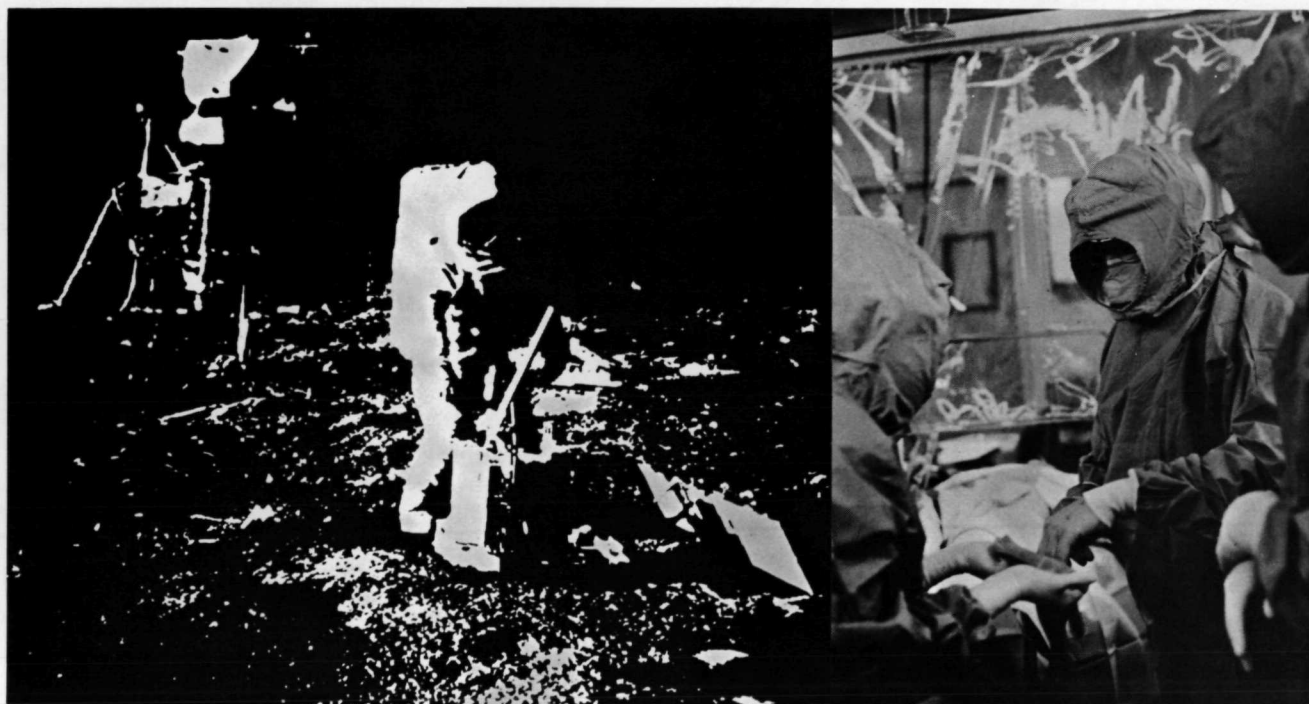

OFFICE OF INDUSTRY AFFAIRS
AND TECHNOLOGY UTILIZATION



JOHN F. KENNEDY
SPACE CENTER

MIDWEST RESEARCH INSTITUTE 425 VOLKER BOULEVARD, KANSAS CITY, MISSOURI 64110

CLEAN ROOM TECHNOLOGY IN SURGERY SUITES

Proceedings of a Symposium Conducted
May 21 and 22, 1971

at

NATIONAL AERONAUTICS AND SPACE ADMINISTRATION
John F. Kennedy Space Center, Florida

Co-sponsored by

NATIONAL AERONAUTICS AND SPACE ADMINISTRATION
Office of Industry Affairs and Technology Utilization
Technology Utilization Office, Code KT
Washington, D.C. 20546

and

MIDWEST RESEARCH INSTITUTE
425 Volker Boulevard
Kansas City, Missouri 64110

Edited and Published by MRI under NASA Contract NASW-1936
(MRI Project 3332-E(D), Reprint MRI-1064)

TABLE OF CONTENTS

	<u>Page</u>
Foreword	vii
Welcome to Conference - James T. Richards	1
Welcome to Kennedy Space Center - General D. F. Callahan, L.L.D.	3
<u>Session I</u>	
Introductory Remarks - H. D. Sivinski	7
Microbiology of Surgery Suites - John A. Ulrich, Ph.D.	11
Principles of Laminar Airflow Systems - Willis J. Whitfield, D.Sc.	33
<u>Session II</u>	
Use of Total Horizontal Laminar Flow Systems in Surgery - J. P. Nelson, M.D.	67
The Use of Total Vertical Laminar Systems in Surgery - Charles O. Bechtol, M.D.	81
Use of a Vertical Laminar Flow System Over the Operating Field - Richard E. Clark, M.D. and Kurt F. Bemberg, P.E.	93
Experience with a Wall-Less Horizontal Clean Air System During Total Hip Replacement - Carl L. Nelson, M.D.	107
Improving the Air Environment of the Operating Room - Harry Buchberg, Professor	117
<u>Session III</u>	
The Application of Laminar Airflow to Surgical Operating Rooms - John G. Whitcomb, M.D.	131
Asepsis and the Operating Room - H. C. Amstutz, M.D.	135
<hr/>	
New Hips for Old; Total Prosthesis Replacement - Irwin S. Leinbach, M.D.	143

TABLE OF CONTENTS (Concluded)

	<u>Page</u>
<u>Session IV</u>	
Forum	165
<u>Participants and Attendees</u>	
Biographical Sketches of Participants	193
List of Attendees	207

FOREWORD

Clean room technology was born because of the need by the manufacturing community for quality assurance and reliability in complex equipment. The first breakthrough came in the middle 1950's when airborne dust was recognized as the common enemy in the manufacture of small, high-tolerance equipment. This led to the development of particle detectors and methods for maintaining dust-free environments; most notable of which was the use of the laminar flow principle by Dr. Willis Whitfield of Sandia Laboratories in December 1960. Clean room technology grew rapidly. The first laminar flow bench was installed for the Bulova Watch Company in April 1962. NASA's mission requirements for extraordinarily complex systems soon made it the leader in the development of clean room technology. By 1964, the medical community recognized the potential of clean rooms in medicine and the first microbiological tests of laminar flow in hospital areas were performed by USPHS. By 1966, the first medical operating laminar flow suite was used at Bataan Memorial Hospital in Albuquerque under the direction of Dr. John G. Whitcomb. Since this time more than 100 clean room operating suites have been installed in U.S. hospitals.

Last year, the MRI Biomedical Applications Team assisted a surgeon in locating NASA documents which he used to design and construct his own "clean operating suite." During this activity MRI became aware that there were several different types of "clean room" surgery suites and that laminar flow per se was apparently not the only answer. These observations led to the idea of having a conference on the application of clean room technology to surgery suites, primarily to examine the different types of "clean room" surgeries, to explore the total application of clean room technology, and provide open discussion on the problems associated with the use of clean room technology in surgery.

The conference achieved its goals in a realistic manner. Basic types of surgical clean rooms were presented, along with their advantages and disadvantages. Clean room technology was considered in its proper perspective, as an adjunct to good surgical procedure and not as a panacea. The principles of clean room technology were presented, as well as the criteria for their application to surgery. The inherent problems of comparing different types of clean rooms were discussed and several critical areas uncovered which lack the scientific information for valid conclusions.

This conference is the first step in an effort by Midwest Research Institute to mount an all-out effort to develop objective information on the application of clean room technology to medicine. We will use the research expertise of our institute to work with several of the symposium's participants toward our goal.

Clean Air in Hospitals: A Twelvemonth of Gains

● THE TWELVE MONTHS BETWEEN September, 1970 and September, 1971, have witnessed remarkable gains in the number of U.S. hospitals utilizing the aerospace industry development called "contamination control," in this instance use of HEPA-filtered air to create ultra clean environments for surgery or patient care. In one year's time, confirmable installations have more than tripled (see "Census" in this issue). In contrast to a year ago, smaller hospitals in smaller cities now are well represented.

THE STRIKING ADVANCES of the past year can be accounted for chiefly by the conviction among or-

thopaedic surgeons that the risk of post-operative infection in total hip joint replacement operations probably is substantially lowered if the operation is performed in an atmosphere of HEPA-filtered air. There seems little question that a majority of the installations currently being made or recently made have been at the instance of orthopaedic men.

HOWEVER, IT'S NOTICEABLE, on a more fundamental note, that as new hospitals are planned, inclusion of permanent laminar flow surgeries now are often a part of the basic planning, making it clear that planners are increasingly

aware of the technique. The "literature" is on the increase; and such events as this year's symposium in May on clean room technology in surgery suites, sponsored by NASA at Cape Kennedy, and attended by a large group of U.S. surgeons, are aiding in spreading information. So are strong bio-medical programs at the annual meetings of such societies as the American Association for Contamination Control. In the following pages, cc cites opinions and experiences of two leading U.S. surgeons on the use of contamination control techniques and some results; and, through the "Census," concretely illustrates the spread of the technique.

The Use of Total Vertical Laminar Air Systems in Surgery

By Dr. CHARLES O. BECHTOL
Clinical Professor of Orthopaedic
Surgery at UCLA
Los Angeles, California

● THE PROBLEM of surgical infection has been lessened greatly in the past few centuries and has gone through many stages, such as the antiseptic phase, the aseptic phase, the development of the proper principles of surgical technique, and the antibiotic phase. The achievement of a low infection rate is an extremely complex problem and involves the cooperation of a large number of people. The clean room technique may offer an additional weapon in the fight against surgical infection. It is quite evident that extensive careful studies will be necessary to evaluate and clarify the role of the clean room in fighting surgical infection. The purpose of this paper is to report the experience of over 850 hours in a vertical flow clean room surgical enclosure, and to state the surgeon's point of view on the desirable design criteria for such a

This paper was delivered at the "Symposium on Clean Room Technology in Surgery Suites" held at the John F. Kennedy Space Center, sponsored by NASA's Office of Industry Affairs and Technology Utilization. Permission to publish has been granted by Mr. James T. Richards, OIATU, and by the author. Proceedings of the entire Symposium will be available in October from Midwest Research Institute, 425 Volker Blvd., Kansas City, Mo.

clean surgical enclosure.

Design Criteria

The two major considerations in design of a clean operating enclosure are:

1. A class 100 unidirectional flow area in which to successfully accomplish the surgical procedure.
2. An adequate sterile envelope or operating suit for the surgical personnel.

The Clean Operating Enclosure

1. *Size*—An enclosure 10x10 feet appears to be adequate for almost all procedures (Mr. Charnley's* original room was 7 by 7 feet and was satisfactory only for the very specialized hip operation. Minimum height of the ceiling in the clean area should be 7 feet 6 inches. (The installation discussed here is a clean enclosure placed in an existing operating theatre. This has the advantage of being less expensive, it excludes the non-surgical personnel, it can easily be placed in an established operating room and if necessary can be dismantled and moved to another area. Further discussions are related to this type of enclosure).

2. *Mobility of surgical personnel.* This is perhaps the most important of all criteria, and here the clean

*Charnley is the British surgeon who pioneered a technique for effecting total hip replacements, using a clean room.

room application differs markedly from its use in industry. In industry it is possible to place the work and the worker in such position that the flow of air will be in the proper direction and there will be no possibility of contamination by reverse turbulence. In the operating room this is not possible because the surgeon must be free to move about the patient in any position as necessary. This particularly applies when a complication of the operation arises, when complete freedom of mobility by the surgical team, to move about the patient and to change from one side to another, is an absolute necessity. It should be noted that this necessity for mobility applies not only to the surgeon but to the entire surgical team as well as to instrument tables.

3. *Lighting of the clean surgical area.* The conventional type of lighting with its large overhead surgical lights is difficult to apply in the clean room concept because it can create reverse turbulence. Several small spot lights of appropriate size can solve this problem. Such lights, which are freely mobile, will not cause reverse turbulence and can give shadow-free illumination. The use of fibre-optics may be helpful in illuminating a deep surgical cavity, though it must be remembered that fibre-optics do not give shadow-free illumination, but a point source of illumination.

E. Other Accomplishments

1. Lectures: During the report period, several activities outside the normal process of problem-oriented interaction with the medical community were accomplished by MRI-BA Team members.

- Dr. Tom Castles gave a talk on technology utilization at the annual meeting of the Indiana Hospital Association. Immediately following the talk, he appeared on a local television program and discussed medical benefits from space technology. The film "Biomedical Applications of Space Technology" was retained by IHA and shown over their statewide close-circuit television network.

- Dr. Serge Zilber conducted a seminar for medical staff and graduate students from the Wisconsin College of Medicine, Milwaukee County General Hospital, and the VA Hospital, Woods, Wisconsin.

- Dr. Zilber attends the regular Saturday seminars on Physical Rehabilitation at Kansas University Medical Center. He recently lectured on his work in the measurement of impairment in the motor function due to Parkinsonism.

- Jack Stacy gave a talk at the joint NASA/International Association of City Managers meeting at Kennedy Space Center. He discussed successful applications of NASA management control technology by local government. He has furnished further guidelines to several cities desiring to use such technology in the management of their cities.

- Jack Stacy spoke at a meeting of the County Club Plaza Lions Club on the medical benefits of space technology. This subject was appropriate due to the Lions' involvement in sponsoring medical projects, especially with reference to eyes.

- Dr. Zilber was the speaker at the general meeting of the Meningomyelocele Association of Greater Kansas City. He presented the NASA TU films as well as the results of other efforts in Biomedical Engineering to approximately 100 parents of children with meningomyelocele.

- Miss Christine Guenther presented MEDATA to a San Antonio group at Southwest Research Institute on 6 October 1971.

- MRI's BA Team has been supporting the NASA-sponsored TELEMED project at the Space Science Research Center of the University of Missouri. We attended the early coordinating meetings and have conducted a search of NASA literature that yielded 750 documents of which 93 were judged relevant by the investigator.

2. Documentation: Section III-A-5 describes the manner in which we documented two examples of significant utilization of NASA technology. The two documents are contained in Section I. The first was prepared on a clean operating room for Barnes Hospital Complex in St. Louis, Missouri, and the second on the management center at Kansas City, Missouri, used during construction of the new Kansas City International Airport.

3. Professional meetings attended: Dr. Serge Zilber attended the 23rd Annual Conference on Engineering in Medicine and Biology in Washington, D. C., on 16-18 November 1970.

Miss Christine Guenther attended the AMA National Symposium on Computer Systems in Medicine on 16-17 February 1971.

Dr. Serge Zilber and Dr. Thomas R. Castles attended the Neuro-electric Conference at Brooks AFB in March 1971.

4. Publicity: The MRI-BA Team was interviewed by a reporter from the Tulsa TRIBUNE. The text of the resultant story is shown in Figure 28.

Information and assistance was given to Fortune magazine for a future article on Secondary Benefits of Space Technology. Pictures and data on Dr. Clark's Clean Room and references to other clean room contributions of NASA were of most interest to the reporter.

Aerospace Works for Everybody

By CHARLES SATERLEE
Of The Tribune Staff

KANSAS CITY—How do you put to everyday use the sophisticated techniques developed to lubricate moving parts in the unspeakable cold of outer space?

What makes morphine an addictive drug? And if you knew the answer to that, how could you use the answer to treat drug addicts—both the furtive, back-street mainliners and the respectable citizens in hospital beds who are given it for pain and find themselves needing more and more?

How do you reduce significantly the danger of infection in the surgical theater, particularly in those operations that require an incision to remain open a long time for the surgeon to do his work?

Malaria is still the world's second biggest killer. How do you evaluate a cure and be sure its side effects are not serious—or lethal?

These are some of the questions that get attention at Midwest Research Institute in Kansas City.

To find the answers, MRI people draw on aerospace technology, on the work of other private researchers, on results achieved in other commercial laboratories. They look to any source that might be helpful because that is the way science, and applied science

in particular, forges new answers to old questions.

MRI researchers took oxygen hoses developed for astronauts in space and derived a new device that measures breathing rate more accurately to help hospitals improve inhalation therapy techniques.

The solid lubricants developed for outer space are already in use on your new car. Ball joints are covered with a thin film of the solid lubricant which is molybdenum disulfide. It will withstand extremes of temperature and it is durable. It can be used as a practically permanent lubricant for door hinges.

One day it may do away with oil lubrication in industrial plant machinery and eliminate with it the problem of getting rid of old oil sludge.

There's even one poignant little project conducted with General Electric Co. that adapted astronaut toilet facilities so they could be used by children with cerebral palsy who have difficulty with normal bodily functions.

The Hydrojohn, as it is called, results in more instruction time for the patients and permits them to take field trips where they might not otherwise be able to go.

Much of MRI's work comes under the heading of "technology transfer"—taking new products or processes and finding even newer uses for them.

The non-profit institute supports itself from grants and from selling its research to private and public clients. It was founded in 1945.

By 1961 it had become involved in the aerospace program under contract with the National Aeronautics and Space Administration.

CHARLES N. KIMBALL, president, recalls: "We were probably ahead of our time. But teflon frying pans sound a little primitive today. Besides, NASA didn't invent teflon. It just helped develop it."

There's nothing new about government research spilling over into civilian technology. It has been going on for years.

The electronic computer is a prime example. The jet engine and radar are two more. Kimball says, "The incremental impact of NASA is tremendous. When you had radar before World War II, you had 75 per cent of television right in your pocket."

The mushrooming use of computers needs no emphasis. But the economic benefits continue to multiply from government research. The orbiting communications satellite system may well be the next tremendous bonanza.

Far more versatile than land lines and with infinitely greater capacity, they will almost assuredly touch off a multi-billion dollar industry when the growing pains stage is finished.

But ideas come from many sources and Midwest Research works on other things. It is bringing a new scientific approach to crime laboratories. It is adapting existing techniques to serve city planners. MRI has set up a central planning and policy room to systematize construction of Kansas City's new international airport.

The institute is making progress in waste disposal, air pollution and it is helping farmers fight insect infestation.

JOHN E. STACY JR. is manager of technology utilization. He also heads the bio-medical team which does original work and collaborates with other companies.

Part of that effort concerns the "clean room" concept developed for aerospace assemblers. A clean room may be roughly defined as any enclosed area where there is nearly total control over all living or non-living particles in the air, with temperature, humidity and pressure control.

The application to hospitals is obvious. But workable arrangements must be devised.

Another NASA-developed device is now helping doctors measure pressure within the heart of cardiac patients. Still another space technique used to determine the presence of life on other planets is being applied to new bacterial tests on human urine.

If all this sounds like a catalogue

of projects, that's about what it is, because the list of MRI projects would require columns.

But there's time, too, for the original research. **Thomas R. Castles, Ph.D.**, is director of the bio-medical application team and principal pharmacologist.

Dr. Castles is trying to find out why people get addicted to morphine. What makes it addictive, he wonders? And he has a hypothesis he's working on under a research grant.

He is looking at the action of morphine on the brain cells. "We think morphine binds with a cellular substance," he says. "We think that in some brain cells there are silent or passive receptors which do not produce any visible drug effect. Yet the drug binds itself to them and stays there."

"This causes them to reproduce themselves, thus creating more brain cells that are vulnerable to morphine. The result is that the brain soaks up more and more morphine."

Dr. Castles may be wrong, he may be right. Or even more tantalizing, he may be almost right. But whatever happens he will add another grain of knowledge and its application in helping man and society.

That's what research is all about. And that's what Midwest Research Institute is all about.

INNOVATE

The Tulsa Tribune

WEDNESDAY, JULY 21, 1971

Page 1B

Tribune Photos by LEWIS JARRETT

Figure 28

Page Intentionally Left Blank

IV. STATISTICS OF MRI ACTIVITY DURING THE REPORT PERIOD

A. Activity Statistics

Problems:

New Problems Accepted	86
Problems Rejected	8
Problems Inactivated	141
Problems Reactivated	5
Total Problems Currently Active	125

Problem Statements:

Preliminary Problem Statements Prepared	80
Problem Statements Submitted for Review	0
Problem Statements Disseminated	0
Responses to Problem Statements	5

Searches:

RDC Computer Searches Initiated	47
Other Searches Initiated	4
Searches Evaluated by Team Personnel	44
Searches Evaluated by Investigator	24

Transfers:

Potential Transfers Claimed	21
Items Dropped from Potential Transfer Status	48
Currently Active Potential Transfers	22
Transfers Claimed	9

B. Impact Areas

HEALTH AREA IMPACT CATEGORIES	PROBABLE SOLUTION REQUIREMENT							
	Analytic Inst. Systems	System Components (Equipment)	Computer Programs	Prosthetic Devices	Materials/Chemicals	Therapeutic Equipment	Other	Total
Total	40	43	8	3	13	1	17	125
Communicable Disease Det. & Prev.		1						1
Screening & Clinical Diagnosis	1	5	1		1			8
Rehabilitation Medicine	3	5	1	1	2	1	3	16
Artificial Organs					2		1	3
Organ Assist Devices	1	4		1	2			8
Mental Health		1			1			2
Heart Disease Detection & Treatment	5	5	1					11
Cancer Detection & Treatment								--
Ecology		1						1
Health Care Cost Reduction	2		3					5
Remote Health Care Services	1		1				1	3
More/Better Med./Paramed. Personnel								--
Kidney Disease Detection and Treat.								--
Reduction of Infant Mortality	6	3						9
Respiratory Disease Det. & Treat.		3					1	4
Improved Surgical Procedures	3	3			4		2	12
Dental & Oral Disorders Det. & Tr.	3							3
Basic Medical Research Problems	14	10		1			2	27
Other, Miscellaneous	1	2	1		1		7	12

MIDWEST RESEARCH INSTITUTE
BIOMEDICAL APPLICATION TEAM
ACTIVITIES FOR THE PERIOD
Currently Active Problems

I. Problems
Specialty/Requirement Matrix

IV. SYNOPSIS OF THE VARIOUS TYPES AND NUMBER PERIOD

A. Activity Statistics

Problems:

For the first 100 days	90
For the next 100 days	9
Problems indicated	141
Problems solved	5
and results of solving them	100

Problems indicated:

For the first 100 days	100
For the next 100 days	100
Problems indicated	100
Problems solved	100

Research:

For the first 100 days	100
For the next 100 days	100
Research indicated	100
Research solved	100

Transfer:

For the first 100 days	100
For the next 100 days	100
Transfer indicated	100
Transfer solved	100

C. Institutions Served

<u>Institution</u>	<u>Location</u>	<u>Code</u>
Kansas University Medical School	Kansas City, Kansas	KU
Univ. of Minnesota Health Sciences Center	Minneapolis, Minnesota	UM
Missouri University	Columbia, Missouri	MU
Univ. of Wisconsin Medical School	Madison, Wisconsin	UW
Creighton University College of Medicine	Omaha, Nebraska	CU
Iowa University College of Medicine	Iowa City, Iowa	IU
Univ. of Mo.-Kansas City Dental School	Kansas City, Missouri	UMKC
Univ. of Nebraska College of Medicine	Omaha, Nebraska	UN
Parsons State Hospital & Training Center	Parsons, Kansas	PSH
United Cerebral Palsy Association	Kansas City, Missouri	UPCA
St. Luke's Hospital	Kansas City, Missouri	SL
Western Missouri Mental Health	Kansas City, Missouri	WMMH
Milwaukee County General Hospital	Milwaukee, Wisconsin	MCGH
United Methodist Hospital of Indiana, Inc.	Indianapolis, Indiana	IMH
Midwest Research Institute	Kansas City, Missouri	MRI
Kansas City Health Department	Kansas City, Missouri	KCH
Washington University School of Medicine	St. Louis, Missouri	WU
Wayne Miner Health Center	Kansas City, Missouri	WMHC
Meningomyelocele Association	Kansas City, Missouri	MAKC

APPENDIX A

EVALUATION OF POTENTIAL TRANSFERS

TABLE I-A

POTENTIAL TRANSFER EVALUATION FORMAT

<u>Technology</u>		<u>Market Impact</u>	
<u>Application</u>	<u>Originator Intent</u>	<u>Type</u>	<u>Awareness</u>
Possible Answers:			<u>Medical Contribution</u>
Direct	Immediate Use	Broad	High
Indirect	Delayed Use	Limited	Low
Modify	Questionable		
Redesign			
Not Applicable			

<u>Transfer Capability</u>			<u>Transfer Outlook</u>	
<u>Funds</u>	<u>Personnel</u>	<u>Equipment and Facilities</u>	<u>Originator Resources Only</u>	<u>With Other Resources</u>
Possible Answers:				<u>Recommended Action</u>
Yes	Yes	Yes	Good	Improved
No	No	No	Poor	Same
		< 6 mo.		Pursue
		> 6 mo.		Wait
				Drop

TABLE II-A

EVALUATION OF CURRENT MRI POTENTIAL TRANSFERS
September 1970

Problem I.D.	Problem Title	Technology		Market Impact			Transfer Capability			Transfer Outlook		Recommended Action	
		Application	Originator Intent	Type	Public Awareness	Medical Contribution	Funds	Personnel	Ancil. Equipment & Facilities	Lead Time	Originator Resources Only		Resources With Other Resources
IU-1	Methods to Detect Localized Blood Turbulence in Human Circulatory System	Indirect Modify	Immediate	Broad	Low	Significant	No	Yes	No	> 6 mo.	Poor	Same	Wait
IU-2	Biotelemetry System for use on Dogs	Direct	Immediate	Limited	Low	Questionable	Yes	Yes	Yes	> 6 mo.	Good	Improved	Wait
IU-3	System to Measure Blood Pressure During Exercise	Direct	Immediate	Broad	Low	Significant	No	No	No	> 6 mo.	Poor	Improved	Wait
IU-6	Analysis of Heart Sounds	Direct	Delayed	Limited	Low	Questionable	Yes	Yes	No	> 6 mo.	Good	Improved	Wait
IU-8	Motion Measurement of Man	Direct	Immediate	Limited	Low	Significant	Yes	Yes	Yes	> 6 mo.	Good	Improved	Wait
IU-9	Respiration Rate Telemetry	Direct	Immediate	Limited	Low	Questionable	Yes	Yes	Yes	> 6 mo.	Good	Improved	Wait
IU-14	Cool Suit for Dogs	Indirect Modify	Delayed	Limited	Low	Questionable	Yes	Yes	Yes	> 6 mo.	Good	Improved	Wait
IU-15	Miniature Electrode	Direct	Questionable	Limited	Low	Questionable	Yes	Yes	Yes	> 6 mo.	Poor	Same	Drop
IU-17	Probable Cardio-tachometer	Direct	Questionable	Limited	Low	Significant	No	Yes	No	> 6 mo.	Poor	Improved	Pursue
IU-23	Monkey Restraint Devices	Direct	Questionable	Limited	Low	Questionable	Yes	Yes	Yes	> 6 mo.	Poor	Same	Drop
IU-32	Computer Processing of 3D Radiographs	Indirect Modify	Delayed	Broad	Low	Significant	Yes	No	No	> 6 mo.	Poor	Improved	Wait
IU-36	Spanner Wrench	Direct	Questionable	Limited	Low	Questionable	Yes	Yes	Yes	> 6 mo.	Poor	Same	Drop

TABLE II-A (Continued)

Problem I.D.	Problem Title	Technology		Market Impact		Transfer Capability			Transfer Outlook		Recommended Action		
		Application	Originator Intent	Type	Public Awareness	Medical Contribution	Funds	Personnel	Ancil. Equipment & Facilities	Lead Time		Originator Resources Only	With Other Resources
IU-42	Heart Rate Alarm	Direct	Delayed	Limited	Low	Significant	Yes	Yes	Yes	> 6 mo.	Good	Improved	Wait
UM-46	Diffusion Rate Computer Program	Indirect	Delayed	Limited	Low	Questionable	No	No	Yes	> 6 mo.	Poor	Improved	Wait
UM-51	Fluorescent Tagging of Bacteria	Direct	Delayed	Limited	High	Significant	Yes	No	Yes	> 6 mo.	Good	Improved	Wait
UM-56	Cleft Palate Airflow Measurements	Direct	Immediate	Broad	Low	Significant	Yes	No	No	> 6 mo.	Poor	Improved	Pursue
UM-61	EEG Telemetry	Direct	Immediate	Broad	High	Significant	Yes	Yes	No	> 6 mo.	Poor	Improved	Pursue
UM-62	EEG Monitoring	Direct	Immediate	Broad	High	Significant	Yes	Yes	No	> 6 mo.	Poor	Improved	Pursue
UM-63	Implantable Materials and Lubricants	Direct	Immediate	Broad	High	Significant	Yes	Yes	No	> 6 mo.	Poor	Improved	Pursue
UM-64	Long Term pH Measurements in the Stomach	Direct	Immediate	Broad	High	Significant	Yes	Yes	No	> 6 mo.	Good	Improved	Wait
UM-45	Center of Gravity Indicator	Direct	Immediate	Broad	High	Significant	No	No	No	> 6 mo.	Poor	Improved	Pursue
UM-49	Measurement of Hand Motion	Direct	Immediate	Broad	High	Significant	No	No	No	> 6 mo.	Poor	Improved	Pursue
UM-83	Bile Duct Pressure Transducer	Direct	Immediate	Limited	Low	Questionable	Yes	Yes	No	> 6 mo.	Poor	Improved	Wait
UM-19	Intercardiac Heart Sounds	Direct	Immediate	Limited	High	Significant	Yes	Yes	No	> 6 mo.	Poor	Improved	Wait

TABLE II-A (Continued)

Problem I.D.	Problem Title	Technology		Market Impact		Transfer Capability		Transfer Outlook		Recommended Action			
		Application	Originator Intent	Type	Public Awareness	Medical Contribution	Funds	Personnel	Ancil. Equipment & Facilities		Lead Time	Originator Resources Only	With Other Resources
CU-1	Cooling System for Brain Research	Direct	Delayed	Broad	High	Significant	No	No	No	> 6 mo.	Poor	Improved	Wait
CU-2	Temperature Telemetry System for Rats	Direct	Delayed	Limited	Low	Questionable	No	No	No	> 6 mo.	Poor	Improved	Drop
CU-6	Ultraminature Cardiac Manometer	Direct	Immediate	Limited	Low	Significant	No	No	No	> 6 mo.	Poor	Improved	Pursue
UN-1	Beat to Beat Cardiotachometer	Direct	Delayed	Broad	Low	Significant	No	No	No	> 6 mo.	Poor	Improved	Drop
UN-3	Blood Pump	Direct	Immediate	Broad	Low	Significant	No	No	No	> 6 mo.	No	Improved	Drop
UW-25	Microspectrophotometer to Measure Chemical in Individual Cells	Direct	Delayed	Broad	Low	Significant	No	Yes	Yes	> 6 mo.	Good	Same	Wait
WW-41	Acceleration Measurements of Human Movements	Direct	Immediate	Limited	Low	Significant	Yes	Yes	No	> 6 mo.	Poor	Improved	Wait
UW-49	Infant Blood Pressure	Indirect Modify	Immediate	Broad	Low	Significant	Yes	No	No	> 6 mo.	Poor	Improved	Drop
MU-36	Measurement of CSF Pressure	Indirect Redesign	Immediate	Limited	Low	Significant	Yes	Yes	Yes	> 6 mo.	Good	Same	Drop
MU-38	EMG Electrodes	Direct	Immediate	Limited	Low	Questionable	Yes	Yes	No	< 6 mo.	Good	Improved	Pursue
KU-31	ECG Electrodes for use During Surgery	Direct or N/A	Delayed	Broad	Low	Significant	No	No	No	> 6 mo.	Poor	Improved	Drop
KU-32	PO ₂ Monitor	N/A	Delayed	Broad	Low	Significant	No	No	No	> 6 mo.	Poor	Improved	Drop
KU-35	Respiratory Flowmeter	Indirect Modify	Immediate	Broad	Low	Significant	No	No	No	> 6 mo.	Poor	Improved	Wait
KU-36	Radial Artery Blood Pressure Monitor	N/A	Immediate	Broad	Low	Significant	No	No	No	> 6 mo.	Poor	Same	Drop

TABLE II-A (Concluded)

Problem I.D.	Problem Title	Technology		Market Impact		Transfer Capability			Transfer Outlook			
		Application	Originator Intent	Public Awareness	Medical Contribution	Funds	Personnel	Ancil. Equipment & Facilities	Lead Time	Originator Resources Only	With Other Resources	Recommended Action
KU-37	ECG Monitor for Surgery	Indirect Redesign	Delayed	Limited Low	Significant	No	No	No	> 6 mo.	Poor	Improved	Wait
KU-42	Measurement of Body Vibrations	Indirect Modify	Immediate	Limited Low	Questionable	Yes	Yes	Yes	< 6 mo.	Good	Same	Pursue
KU-45	Fetal ECG Electrodes	Direct	Questionable	Limited Low	Questionable	No	No	No	< 6 mo.	Poor	Same	Drop
WU-9	Blood Pressure Measurements in Rats	Indirect Redesign	Immediate	Limited Low	Significant	Yes	Yes	Yes	< 6 mo.	Good	Same	Wait
WU-1	Laser Effects on Eye and Skin	Indirect	Delayed	Limited Low	Significant	Yes	Yes	N/A	< 6 mo.	Good	Same	Wait
WU-10	Temperature Telemetry	Direct	Delayed	Limited Low	Questionable	No	Yes	No	< 6 mo.	Poor	Improved	Wait
WU-11	Mapping of Molecular Structures	Indirect Modify	Delayed	Limited Low	Questionable	Yes	No	No	< 6 mo.	Poor	Same	Wait
WU-17	Tremor Accelerometer	Indirect Redesign	Delayed	Limited Low	Questionable	Yes	Yes	No	> 6 mo.	Poor	Same	Wait
UMKC-1	Dental Pulp Temperature	Indirect Redesign	Delayed	Broad High	Significant	No	No	No	> 6 mo.	Poor	Improved	Wait

TABLE III-A

EVALUATION OF CURRENT MRI POTENTIAL TRANSFERS
October 1971

Problem I.D.	Problem Title	Technology		Market Impact			Transfer Capability			Transfer Outlook			
		Application	Originator Intent	Type	Public Awareness	Medical Contribution	Funds	Personnel	Equipment and Ancil. Facilities	Lead Time (month)	Originator Only Resources	With Other Resources	Recommended Action
IU-37	Encapsulation of Electronics	Direct	Immediate	Limited	Low	Significant	Yes	No	Yes	> 6	Good	Same	Wait
IU-55	Miniature Pulsatile Pump	Direct	Questionable	Limited	Low	Questionable	No	No	No	> 6	Poor	Same	Wait
UM-19	Intercardiac Transducer	Direct	Immediate	Broad	High	Questionable	No	Yes	Yes	> 6	Poor	Improved	Wait
UM-49	Measurement of Hand Motion	Direct	Immediate	Broad	High	Significant	No	No	No	> 6	Poor	Improved	Pursue
UM-63	Implantable Materials and Lubricants	Direct	Immediate	Broad	High	Significant	Yes	Yes	No	> 6	Poor	Improved	Pursue
UM-129	Stethoscope for High Noise Environment	Indirect	Questionable	Limited	Low	Significant	No	Yes	Yes	> 6	Poor	Improved	Wait
UM-140	Survival of Biological Cells in Vacuum	Direct	Delayed	Limited	Low	Significant	Yes	Yes	Yes	> 6	Good	Same	Wait
UM-141	Thermo-Osmosis	Direct	Delayed	Limited	Low	Significant	Yes	Yes	Yes	> 6	Good	Same	Wait
UM-143	Detection of Bio-Generated Magnetic Fields	Direct	Immediate	Broad	High	Significant	No	Yes	Yes	> 6	Poor	Improved	Pursue
CU-6	Ultraminiature Cardiac Manometer	Direct	Immediate	Limited	Low	Significant	No	No	No	> 6	Poor	Improved	Pursue
WU-3	Mechanical Stresses in Aortic Valves	Direct	Immediate	Broad	High	Significant	No	Yes	Yes	> 6	Poor	Improved	Pursue
KU-35	Integrating Volume Flowmeter	Indirect Modify	Immediate	Broad	Low	Significant	No	No	No	> 6	Poor	Improved	Wait
KU-42	Measurement of Body Vibrations	Indirect Modify	Immediate	Limited	Low	Questionable	Yes	Yes	Yes	< 6	Good	Same	Pursue

TABLE III-A (Concluded)

Problem I.D.	Problem Title	Technology		Market Impact			Transfer Capability			Transfer Outlook			
		Application	Originator Intent	Type	Public Awareness	Medical Contribution	Funds	Personnel	Equipment and Ancil. Facilities	Lead Time (month)	Originator Resources Only	With Other Resources	Recommended Action
SL-1	Management Information Center	Direct	Delayed	Broad	High	Questionable	Yes	Yes	Yes	> 6	Good	Same	Wait
MGCH-1	NMR Applications to Cardiac Output Measurements	Indirect	Immediate	Limited	Low	Significant	Yes	Yes	Yes	> 6	Poor	Improved	Pursue
MGCH-2	Cortical Mapping of Visual System Projections	Direct	Immediate	Limited	Low	Significant	Yes	Yes	Yes	> 6	Poor	Improved	Pursue
KCH-1	Computerized Medical Surveys	Modify	Questionable	Broad	High	Significant	No	Yes	Yes	< 6	Poor	Improved	Wait
WMHC-1	Rapid Detection of Bacteria in Urine	Direct	Immediate	Broad	High	Questionable	No	No	No	> 6	Good	Same	Wait
UN-13	FM Telemetry	Direct	Immediate	Broad	High	Questionable	Yes	Yes	Yes	< 6	Good	Same	Wait
UN-14	Implantable Transmitter	Direct	Immediate	Broad	High	Questionable	Yes	Yes	Yes	< 6	Good	Same	Wait
MAXC-1	Emergency Medical Data Retrieval System	Modify	Immediate	Limited	Low	Significant	No	No	No	< 6	Poor	Improved	Pursue
CRS-2	Audio Communicator	Modify	Immediate	Broad	High	Questionable	Yes	No	No	> 6	Poor	Improved	Pursue

APPENDIX B

EVALUATION OF ALL CURRENTLY ACTIVE PROBLEMS
(OCTOBER 31, 1971)

TABLE I-B

EVALUATION OF CURRENT MRI PROBLEMS
October 1971

Problem	Date Received	Date Last Action	Status	Investigator Interest	Public Impact	Medical Impact	Space Technology Relevance	Investigator Technical Capability	Investigator Resources	Closure Potential
IU-37, Encapsulation of Electronics	12/69	7/71	E	H	L	H	H	H	H	H
IU-48, Limb Movement During Free Fall	4/70	7/71	D	H	L	H	H	H	L	L
IU-51, A System to Make Holograms of Falling Bodies (Animal)	6/70	10/71	D	H	L	H	H	H	L	L
IU-53, Miniaturized Heat Exchanger	6/70	1/71	D	H	H	H	H	L	H	L
IU-54, Miniaturized Oxygenator	6/70	1/71	D	H	H	H	H	L	H	L
IU-55, Miniaturized Pulsatile Pump	6/70	1/71	E	H	H	H	L	L	H	L
IU-58, Air Flowmeter with Low Resistance	10/70	7/71	B	H	L	H	L	H	H	L
IU-59, Body Heat Regulation	12/70	7/71	B	H	H	H	L	H	H	L
IU-60, Body Sweat Regulation	12/70	7/71	B	H	H	H	L	H	H	L
IU-61, Heat Tolerance	12/70	7/71	B	H	H	H	L	H	H	L
IU-62, Heat Acclimatization	12/70	7/71	B	H	H	H	L	H	H	L
IU-63, Method to Measure 2,3 DPG of the Blood During Exercise	2/71	7/71	B	H	L	H	L	H	H	L
IU-64, Method to Measure Shift of Body Fluids During Exercise	2/71	7/71	B	H	L	H	L	H	H	L
IU-65, Blood Pressure Measurements in Small Dogs	2/71	7/71	B	H	L	L	L	H	H	L
IU-66, Pressure-Controlled Perfusion Pump	2/71	7/71	B	H	L	L	L	H	H	L
IU-67, Hot Wire Anemometers for Air Volume Flows	2/71	7/71	B	L	L	L	L	H	H	L
IU-68, Bone Growth Detection	3/71	5/71	B	H	L	L	L	H	H	L
IU-69, Negative Body Pressure	6/71	9/71	A	H	L	H	H	H	H	L
UM-19, Intercardiac Transducer	4/68	9/71	E	H	L	H	H	H	H	H
UM-33, Pulmonary Instrument	9/68	7/71	D	H	L	H	H	H	H	H
UM-48, Measurement of Head Motion	11/69	10/71	D	H	H	H	L	L	L	L
UM-49, Measurement of Hand Motion	11/69	10/71	E	H	H	H	L	L	L	L
UM-56, Cleft Palate Airflow Measurements	1/70	8/70	F	F	H	H	H	H	L	L
UM-57, Physiological Monitoring	1/70	8/70	F	F	H	H	H	H	L	L
UM-58, Low Surface Energy Materials and Lubricants	1/70	10/71	F	F	H	H	H	H	L	L
UM-63, Implantable Materials and Lubricants	1/70	6/71	E	H	H	H	H	H	L	L
UM-79, Intracranial Pressure	2/70	10/71	F	F	H	H	H	H	L	L
UM-80, Computer Data Collection	2/70	6/71	D	L	H	H	L	L	H	L
UM-84, Physiologic and Hematologic Response	2/70	9/70	D	L	L	L	L	L	L	L
UM-89, Development of Atherosclerosis in Man	2/70	6/71	D	L	H	H	H	H	H	L
UM-90, Gastrointestinal Motility Related to Space Diets	2/70	10/71	D	L	L	H	L	H	H	L

H = High
L = Low
TA = Transfer accomplished
U = Unknown
D = Evaluation
A = Problem Definition
B = Information searching
C = Problem abstract dissemination
E = Potential transfer
F = Follow-up activity

TABLE I-B (Continued)

Date Received	Date Last Action	Inves-tigator Status	Inves-tigator Interest	Public Impact	Medical Impact	Space Technology Relevance	Inves-tigator Technical Capability	Inves-tigator Resources	Closure Potential
2/70	9/71	B	U	L	H	H	H	H	H
6/70	8/70	D	U	L	H	H	H	H	H
8/70	8/70	B	U	H	L	L	H	H	U
8/70	12/70	B	H	H	L	L	L	L	L
8/70	12/70	B	H	H	H	L	L	L	L
8/70	1/71	F							TA
9/70	12/70	B	L	L	L	L	H	H	U
9/70	1/71	D	L	L	U	H	H	U	U
9/70	1/71	B	H	L	H	H	H	H	H
11/70	1/71	B	H	L	L	H	H	H	U
1/71	1/71	B	H	H	H	H	H	H	H
11/69	10/71	E	H	H	H	H	H	L	L
11/69	6/71	B	H	H	H	H	L	L	L
11/69	10/71	F							TA
11/69	6/71	B	H	H	H	U	L	L	L
11/69	10/71	F							TA
5/70	7/71	B	H	H	H	L	H	L	L
8/70	7/71	B	L	L	L	L	U	H	L
8/70	9/71	B	L	L	L	L	U	H	L
9/70	5/71	C	L	L	L	L	L	L	L
12/69	3/71	C	L	L	L	L	L	L	L
8/69	10/71	E	H	L	H	H	L	L	H
10/69	6/71	E	H	L	L	H	H	H	H
10/70	3/71	B	H	L	L	H	L	H	H
1/71	1/71	D	H	H	H	H	H	L	L
8/70	1/71	E							TA
9/70	1/71	F							H
10/70	1/71	B	H	H	H	H	H	H	L
10/70	1/71	A	H	H	H	L	H	L	L
10/70	1/71	B	H	L	H	H	L	L	L
10/70	10/71	E	H	H	H	H	H	H	L
10/70	1/71	E	H	H	H	H	H	H	L
1/71	1/71	F							TA
2/71	3/71	B	H	H	H	U	H	L	L
2/71	3/71	B	H	H	H	U	H	L	L
11/70	5/71	A	H	H	L	H	L	L	L
11/70	5/71	D	H	H	H	H	L	H	L
1/71	7/71	E	H	H	H	H	H	H	H
3/71	6/71	D	H	H	L	H	L	L	L
1/71	1/71	F							TA
2/71	4/71	A	H	H	L	L	H	H	L
5/71	10/71	E	H	H	L	H	L	L	L
7/71	10/71	E	H	L	L	H	H	H	L
7/71	10/71	E	H	L	L	H	H	H	L
8/71	10/71	F							TA
10/71	10/71	E	H	H	L	H	L	L	H
10/71	10/71	E	H	H	L	H	L	L	H

UM-58, Solid State Light Detector
 UM-59, Foot Force Measurement
 UM-60, Transducers and Transmitters for Fish for Underwater Pollution Research
 UCPA-1, Self-Propelled Wheelchair
 UCPA-2, Wheelchair Transport
 UCPA-3, Human Waste Container System
 MU-44, Physiological Effects of Magnetic Fields
 MU-45, Automatic Servo Systems
 MU-47, Methods for Automatically Monitoring Arrhythmias
 MU-48, Integrated Circuit Amplifiers
 MU-49, TELEMED
 WU-3, Mechanical Stresses in Aortic Valves
 WU-4, Carbon Implant Materials
 WU-5, Clean Room Technology
 WU-6, Measurement of Cardiac Chamber Volume
 WU-7, Biocompatible Materials
 WU-16, Cardiac Output Measurement
 WU-21, Digital Display of ICU Patient Parameters
 WU-22, Video Display of Analog Wave Shapes
 WME-1, Automatic Blood Pressure Measurement
 UMKC-5, Electropotential of Tooth Nerve
 KU-35, Flowmeter for Respiration Measurement
 KU-42, Measurement of Body Vibrations
 KU-48, Local Pressurized Oxygen Applicator
 KU-49, Abrasive for Bone Removal
 KU-50, Prolonged Limitation of Mobility
 SL-1, Management, Information Center
 SL-2, Correction of Physiological Pressure Measurements
 SL-3, IV Feeding in Hyperbaric Chamber
 SL-4, Semi-Permanent Blood Sampling System
 SL-5, Cardiac Output Measurement in Hyperbaric Chamber
 MCGH-1, NMR Applications to Cardiac Output Measurements
 MCGH-2, Cortical Mapping of Visual System Projections
 MCGH-5, Current Limiting Circuit
 MCGH-4, Superconductive Cooling
 MCGH-5, Equidistant Scanning
 IMH-1, Clean Operating Room
 IMH-2, Hospital Bacteria Counting System
 KCH-1, Computerized Medical Surveys
 KCH-2, Pharmaceutical Inventory System
 MRI-1, Air Shower for Rodent Quarters
 MRI-2, Methyl Alcohol Fuel Cell
 WMHC-1, Rapid Detection of Bacteria in Urine
 UN-13, FM Telemetry
 UN-14, Implantable Transmitter
 CRS-1, Anti-fogging Agent for Surgical Mask
 MAKC-1, Emergency Medical Data Retrieval System
 CRS-2, Audio Communicator

TABLE I-B (Concluded)

	Date Received	Date Last Action	Status	Investigator Interest	Public Impact	Medical Impact	Space Technology Relevance	Investigator Technical Capability	Investigator Resources	Closure Potential
UM-92, Respiratory Analysis	4/70	1/71	D	H	H	H	L	H	L	L
UM-95, Low Dead Space Breathing Mask	5/70	10/70	D	H	H	H	L	H	H	L
UM-96, Computer Data File System Design	5/70	1/71	D	H	H	L	H	H	H	L
UM-97, Computer Data File Management	5/70	1/71	D	H	H	L	H	H	H	L
UM-100, Charging System to Prolong Life of Ni-Cad Batteries	6/70	10/71	F	H	H	L	L	H	H	TA
UM-113, EKG Telemetry System for Active Worker	8/70	9/70	B	H	H	H	L	H	H	L
UM-114, Portable Respiration Analyzer for Active Worker	8/70	9/70	B	L	L	L	L	H	H	L
UM-115, Implantable Time Capsule	9/70	12/70	B	L	L	L	L	H	H	L
UM-116, Flexible Pressure Transducer	9/70	11/70	B	L	L	L	L	H	L	L
UM-117, Constant Velocity Cable Take-up	9/70	11/70	B	L	L	L	L	H	L	L
UM-118, Biotelemetry	9/70	11/70	B	H	H	H	L	H	H	L
UM-119, Magnetic Impulse Detector	9/70	1/71	B	H	H	H	L	H	H	L
UM-120, Implantable Flexible Electrodes	9/70	12/70	B	H	H	H	L	H	H	L
UM-121, Implantable Encapsulation of Electronics	9/70	12/70	B	L	L	L	H	H	H	L
UM-122, Implantable Miniature Pump	9/70	1/71	B	H	L	L	L	H	H	L
UM-123, Mass Spectrometer Computer Interface	9/70	10/70	B	L	L	L	L	L	L	L
UM-124, Hyperbaric Chamber Design	9/70	10/70	B	L	L	L	L	L	L	L
UM-125, Blood Sampling in Hyperbaric Chamber	9/70	10/70	B	L	L	L	L	L	L	L
UM-128, Human Heart Volume Measurements	9/70	6/71	B	H	H	H	L	H	L	L
UM-129, Stethoscope for Use in High Noise Environments	9/70	1/71	E	L	H	L	L	H	H	L
UM-130, Current Measurement to a Nonlinear Load	9/70	10/71	F	H	L	L	L	L	H	TA
UM-131, Wound Coverings	10/70	12/70	B	H	H	L	L	L	H	L
UM-133, Dry Electrodes	11/70	1/71	B	H	L	L	L	H	H	L
UM-134, Fluorescent Staining of Bacteria Flagella	11/70	6/71	B	H	L	L	L	H	H	L
UM-135, Nonlogging Monitoring Catheter	11/70	12/70	B	H	H	H	L	H	H	L
UM-136, Method to Mark Biological Samples for Automatic Identification	2/71	3/71	B	H	L	L	L	H	L	L
UM-137, Microcalorimetry of Cells	3/71	6/71	D	H	H	H	H	H	H	H
UM-138, Microbeam Laser	3/71	9/71	D	L	H	H	L	L	L	L
UM-139, Viruses Transported in Water	3/71	10/71	D	H	H	H	L	H	H	L
UM-140, Survival of Biological Cells in Vacuum	3/71	10/71	E	H	H	H	H	H	H	H
UM-141, Thermo-Osmosis	4/71	10/71	E	H	H	H	H	H	H	H
UM-142, Four-Channel ECG Recorder	6/71	6/71	A	L	L	L	L	L	L	L
UM-143, Detection of Bio-Generated Magnetic Fields	9/71	10/71	E	H	H	H	H	H	H	H
PSH-1, Transducers for an Ergometer	8/70	1/71	B	H	H	H	L	L	L	L
CU-6, Ultraminiature Cardiac Manometer	4/70	1/71	E	H	H	H	H	H	H	H
UM-28, Hardware and Components for Powered Prosthetic Devices	12/60	1/71	D	H	H	H	H	H	H	H
UM-30, Portable Refrigeration System for Use as a Surgical Tool	12/69	1/71	D	H	H	L	L	L	L	L
UM-38, Airflow Monitor During Speech	12/69	1/71	D	H	H	H	H	H	H	L
UM-48, Tissue Flowmeter	1/70	1/71	B	H	H	L	L	L	L	L
UM-51, Bladder Electrodes	2/70	1/71	D	H	H	L	L	L	L	L
UM-52, Bladder Stimulator	2/70	1/71	B	H	H	L	L	L	L	L
UM-53, Miniature pH Sensing Device	2/70	1/71	B	H	L	L	L	L	L	L
UM-54, Miniature Heart Rate Sensing Devices	2/70	1/71	B	H	L	L	L	L	L	L
UM-55, Miniature Blood Pressure Sensing Devices	2/70	1/71	B	H	L	L	L	L	L	L
UM-56, Miniature pO ₂ Sensing Devices	2/70	8/70	B	H	L	L	L	L	L	L
UM-57, Means to Detect Center of Gravity in a Walking Man	2/70	9/71	B	H	L	L	L	L	L	L

APPENDIX C

BENEFITS OF A WORKING RELATIONSHIP WITH
ELEMENTS OF A PATIENT CARE SYSTEM

JAMES E. CROCKETT, M. D.
J. TENBROOK KING, M. D.
BEN D. McCALLISTER, M. D.

ADULT AND PEDIATRIC
CARDIOVASCULAR
DISEASES

December 24, 1970

410 MEDICAL PLAZA
4320 WORNALL ROAD
KANSAS CITY, MO. 64111
TELEPHONE 931-1884

Dr. Charles Kimball, President
Midwest Research Institute
425 Volker Boulevard
Kansas City, Missouri 64110

Dear Dr. Kimball:

I have indicated to you in previous discussions the fact that there is a technological gap in medicine today. In fact, medicine has been in most instances isolated from the professional engineer; this logistic separation has prevented the transfer of valuable knowledge to the medical profession. Yet scientific advances have been rapid particularly in the area of aerospace research, and it is very important to transmit and apply this new technology to the various fields of medical investigation and patient care.

There are many biomedical problems in medicine today which would benefit from the utilization of the products of research in other fields, and such efforts as the NASA Technology Utilization Program, in my opinion, can provide the necessary vehicle.

Even in a sophisticated medical center such as the Mayo Clinic the importance of such a program is illustrated. During my tenure as a consultant in cardiology and the cardiovascular laboratory at the Mayo Clinic and Mayo Foundation there were specific instances in which progress was blocked because of inadequate transfer of knowledge from the scientific fields. As an example, in 1965 the need for a small portable pocket electrocardiographic tape recorder to detect and define the presence of cardiac arrhythmias in patients with heart disease was defined. Many initial attempts to secure technological help failed and it was difficult to determine whether technology in the aerospace industry had solved many of the electronic details necessary to build such a device. After a considerable amount of time and effort, a pocket recorder was developed and made available for practical patient use in 1969. This delay seems excessive. The present

Dr. Charles Kimball, President
Midwest Research Institute

2.

NASA Technology Utilization Program may have expedited such a project considerably and there are many similar examples of the physician with an idea but no technological advice and know-how.

Our recent experience with Dr. Serge Zilber of your staff has been an important one for the cardiovascular area at St. Luke's Hospital. An initial project has been a relatively small one in proportion to the future possibilities, yet it illustrates the importance of the availability of professional consultation such as Dr. Zilber provides.

We have performed cardiac catheterizations on approximately 90 young people (usually in their teens and often athletes) with heart murmurs who have had evidence of left ventricular outflow obstruction, particularly following physiological stimulation with isoproterenol. There are striking similarities of this group of patients under study with a well recognized form of heart disease, obstructive cardiomyopathy, and it is felt by some that our patients represent an early form of this serious disease. Of concern is the fact that the latter group of patients are prone to sudden and premature death. Yet the left ventricular outflow obstruction may be a dynamic phenomenon in the young patients with mild heart murmurs and may represent a variant of normal, a view which I personally prefer. The importance of more clearly defining the true nature of this problem is obvious.

Of concern has been the accuracy of our transducer-catheter manometer systems and other laboratories in other institutions which I have contacted have had similar observations and concern with confusion of the interpretation of the scientific data. The possibility of overshoot and inadequate frequency response in the biological systems being measured have been raised.

With Dr. Zilber's insight into the problem a research of the literature was carried out, and following Dr. Zilber's advice a sinusoidal-pressure generator* is being built by Midwest Research

* Reference: Steigall, H.F. A Simple Sinusoidal Pressure Generator. Journal of Applied Physiology, Volume 22: 591, 1967 (A NASA project at Brooks Army Hospital).

Dr. Charles Kimball, President
Midwest Research Institute

3.

Institute to permit an accurate evaluation of the frequency response of the catheter-monometer systems in the cardiovascular laboratory at St. Luke's Hospital. Modifications in the present equipment can then be made on a scientific basis in order to increase the confidence limits of the physiological observations so important in this group of patients.

In addition, Dr. Zilber has advised the purchase of a catheter tip monometer to compare direct recordings from the left ventricular cavity to the usual indirect fluid systems. The latter will be obtained through a grant from the St. Luke's Foundation for Education and Research.

Thus, with Dr. Zilber's scientific knowledge, the problem was pinpointed and the solution should be better defined within the near future. Thus, the cooperative efforts of the cardiovascular physiologist and engineer should lead to more accurate definition and solution of important clinical problems.

Other benefits from such an association also have been noted:

- 1) The personnel in the cardiovascular laboratory with varying levels of experience have all become more knowledgeable of their equipment and the physics and electronics involved, a direct educational stimulus.
- 2) Discussions have led to the definition of other problem areas, and potential areas of investigation.
- 3) The importance of biomedical training and exchange of information in the education of sophisticated cardiovascular fellows in our training programs has been realized.
- 4) The need for continued association with biomedical personnel in order to maintain a superb and updated cardiovascular physiological laboratory is obvious.

In the past there have been no opportunities for such an exchange of ideas and association in the Kansas City area to my knowledge.

Dr. Charles Kimball, President
Midwest Research Institute

4.

With the development of a more academically and scientifically oriented medical community, stimulated by the new medical school, there will be continued needs for such a program as the NASA Technology Utilization Program and the service to the community will be invaluable.

Of concern to me is the one obstacle in the program--when a problem is defined and solved there is no present mechanism to carry through with funding for completion of a project. Perhaps NASA, the National Institute of Health or regional medical care funds could be organized to facilitate this important and necessary final step.

If you have further questions concerning my thoughts about the program in general please do not hesitate to call on me.

Sincerely yours,

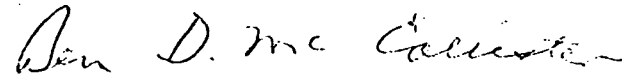

Ben D. McCallister, M.D.

BDM:ms

APPENDIX D

PROBLEM DESCRIPTIONS
(BY HEALTH AREA)

COMMUNICABLE DISEASE DETECTION AND TREATMENT

PROBLEM UM-139: Viruses Transported in Water

The investigator is working in the area of virus infection via the water route. He wanted information on methods to detect viruses in water systems of spacecraft water systems, particularly the closed loop water systems.

A search was made and the information forwarded to the investigator. There was no relevant information.

SCREENING AND CLINICAL DIAGNOSIS

PROBLEM UM-136: Method to Mark Biological Samples for Automatic Identification

The investigator is automating some operations in the laboratories. The automatic analysis equipment he will be assembling will have digital readouts and be compatible with computer processing. At present, the sample identification is entered by hand and he would like a system where the sample could be identified automatically and entered into the computer as the analysis is run. This would eliminate the manual identification of samples and reduce the possibility of error.

A manual search was made of NASA data and this information forwarded to the investigator.

PROBLEM SL-3: IV Feeding in Hyperbaric Chamber

A two-atmosphere hyperbaric bed is used by the investigator to lighten the load on the strained heart of a heart attack victim. The bed is also used in the treatment of other diseases and injuries which require oxygen under pressure. Many patients would derive additional benefits if simultaneous administration of drugs at controlled rate were possible. Since the hyperbaric bed does not have sufficient head room for an interior gravity feeding system, an alternate external system is required.

A proposed system must allow liquids to be transported at a controlled rate from atmosphere pressure into a pressurized environment. Safety and reliability of operation are prime requisites.

A manual search was conducted and it appears that document N66-27150 offers a partial solution.

PROBLEM SL-5: Cardiac Output Measurement in Hyperbaric Chamber

A two atmosphere hyperbaric bed is used by the investigator to lighten the load on the heart of a heart attack victim. The bed is also used in the treatment of other diseases and injuries which require oxygen under pressure.

At times, it is desirable to measure the cardiac output of a patient inside the hyperbaric bed from the exterior of that bed. In particular, the dye dilution method of measurement requires a port to inject the dye and a port for sampling. Two special wall connectors are required, and they should be capable of easy installation on the present bed.

A manual search was conducted, and it appears that document N66-27150 offers a partial solution.

PROBLEM MCGH-1: NMR Applications to Cardiac Output Measurements

The investigator is developing a device capable of measuring total blood flow in a limb. Such measurements require a noninvasive principle such as nuclear magnetic resonance. The technique involves holding the arm in a magnetic field to flip the protons in the blood stream so they can be detected downstream.

The investigator feels that signal detection and conditioning techniques developed by NASA for small signals and small magnetic fields could be applied to the design.

An ARAC search has uncovered six applicable NASA documents. The investigator is modifying the electronic circuitry based on the resultant data.

PROBLEM MCGH-4: Superconductive Cooling

Nuclear magnetic resonance principles are used for measuring blood flow through limbs for diagnostic purposes. The large magnets presently required may possibly be replaced by superconductive magnets if the required equipment is not overly complex.

An ARAC computer search was run.

PROBLEM MCGH-5: Equidistant Scanning

Radioisotope scanners travel on a plane parallel to a patient's table; therefore, the distance between an area of the patient's body and the scintillation detector does not remain constant. Improved scans would be obtained if the distance between the patient and the detector would remain constant during a scan.

A manual search was made of aerospace data and no solution was found.

PROBLEM WMHC-1: Rapid Detection of Bacteria in Urine

The Wayne Miner Neighborhood Health Center provides health care to approximately 25,000 people in the inner-city of Kansas City, Missouri. One of its principal missions is to provide these persons with preventative medical care. One part of this mission consists of periodic visits by the staff to residences in the inner-city to measure blood pressure. Data accumulated by this program show a high incidence of hypertension among this population. Preliminary data from these hypertensive persons who consented to more thorough examination at the clinic suggested a high incidence of bacteriuria. As the result of this observation the Wayne Miner Clinic has been looking for a rapid means of making urinary bacteria counts in the field.

A potential solution to this problem was developed by Dr. Alan Fleig, Goddard Space Flight Center (Tech Brief 71-10055). This instrument can automatically count bacteria in urine samples within 5 - 15 min. This instrument has been tested at the Johns Hopkins Medical School with 5,000 urine samples, and was found to be more sensitive than conventional techniques.

PROBLEM MAKC-1: Emergency Medical Data Retrieval System

This organization is a lay voluntary organization founded by parents of children with meningomyelocele, spina bifida, hydrocephalus, and related birth defects. Recent surgical techniques have been developed which extend the life prospect of these children. However, with numerous surgeries (orthopedic, neurologic, and urologic), the records of these children come in several volumes. An organized set of basic medical data and a means of obtaining the desired data on quick-recall for emergencies (and most treatments are emergencies) is needed. There are approximately 150 children in this association and 250 - 300 in the greater Kansas City area.

The MEDATA program appears to be an ideal solution to this problem. It offers a narrative approach with a flexible outline.

REHABILITATION MEDICINE

PROBLEM IU-48: Limb Movement During Free Fall

The investigator wants to analyze the reorientation of the human body under conditions of free fall (weightlessness) is the absence of a support. A means of orienting the body along its longitudinal axis could have various biomedical applications such as coordination studies, rehabilitative training in muscle control disorders, and caloric input correlations. Data and/or computer programs are needed.

An ARAC computer search was made and several relevant documents were identified from studies of possible astronaut orientation using limb motion. The investigator is evaluating these documents.

PROBLEM UM-48: Measurement of Head Motion

The investigator is working with patients, children primarily, who have muscle control disorders. These patients are receiving rehabilitation training, and it is very difficult to determine the progress they are making. At the present time, the patient is observed by the therapist and a subjective evaluation is made. If the patient progresses slowly and he receives treatments for a long period of time, as long as several years, it is difficult to get an objective accurate plot of his progress.

The investigator feels that standard electronic measurements should be made under controlled conditions and compared with previous measurements of the patient and with measurements of a normal person to arrive at some figure of progress and the amount of disability. One of the measurements desired is the motion of the patient's head about the vertical and horizontal axis.

An ARAC search was run and several relevant documents located. Although several possible solutions have been proposed the investigator has lacked sufficient funds and time to obtain equipment and evaluate these solutions. He has submitted a proposal to the NASA TU Office for funding through one of the NASA centers.

PROBLEM UM-49: Measurement of Hand Motion

The investigator is working with patients, children primarily, who have muscle control disorders. These patients are receiving rehabilitation training and it is very difficult to determine the progress they are making. At the present time, the patient is observed by the therapist and a subjective evaluation is made. If the patient progresses slowly and he receives treatments for a long period of time, as long as several years, it is difficult to get an accurate and objective plot of his progress.

The investigator feels that standard electronic measurements should be made under controlled conditions and compared with previous measurements of the patient and with measurements of a normal person to arrive at some figure of progress and the amount of disability. One of the measurements desired is the motion of the patient's hand as he reaches for an object in front of him on a table.

An ARAC search was run on the problem and several relevant documents located. The problem was presented to investigators at the Ames Research Center and they proposed a solution using magnetometers. The investigator at the present time does not have sufficient funds to purchase the necessary equipment to evaluate the possible solution. He has submitted a proposal to the TU Office for funding through one of the NASA centers.

PROBLEM UM-116: Flexible Pressure Transducer

The fitting of prosthetic devices to the handicapped is very difficult. Pressure points, that may not be immediately evident, can cause extreme discomfort and even ulcerations. The investigator would like to construct a pressure-sensitive mat (with pressure sensors arranged every 1/4 sq. in.) which would be scanned and monitored. Other systems are available, but are too expensive. Flexible pressure-sensitive compounds are needed for the construction of this mat. It is hoped that such a system could determine the pressure points between the human body and prosthetic devices.

An ARAC search was run and one relevant document was found. The investigator is evaluating the document.

PROBLEM UM-117: Constant Velocity Cable Take-up

The investigator is evaluating the nerve damage in handicapped patients. One of the tests that he uses is to extend a member of the body, such as the arm, by pulling on it at a constant velocity from a retracted to an extended position. If there is motor nerve damage, the muscle will tend to be spastic and will cause a jerking restraining force. This restraining force is an indication of the amount of motor damage that is present. The test is presently being done manually by pulling on the body member through a force gauge. This system is very inaccurate.

An ARAC search was run and results forwarded to the investigator. ~~Four documents were considered relevant and forwarded to the investigator~~ for evaluation.

PROBLEM UW-28: Hardware and Components for Powered Prosthetic Devices

A large number of today's paraplegic sufferers could enjoy full economic and social membership in society if they were equipped with improved prosthetic devices. Commercially available hardware presently serving in this area is neither compact nor reliable enough to adequately satisfy the needs of this application. Components needed include miniature servo motors and mechanisms (hydraulic, pneumatic, electric, etc.), switching circuits for their operation, and limb motion hardware such as knee joints, elbow joints and others.

Information is being sought which may have been developed for space suits, particularly limb motion hardware. Other components may be found in apparatus using miniature remote control systems, special automatic instrumentation apparatus, and systems designed to operate in hazardous environments.

PROBLEM UW-38: Air Flow Monitor During Speech

The investigator desires to reproduce the cycle-by-cycle variations in the airflow that escapes from the vocal cords during human speech. Theoretically, the waveform is triangular in shape and typically repeats 75-250 times per second. The peak amplitude of airflow velocity is estimated to be as high as 1,200 cc/sec. There is direct correspondence between the airflow velocity and the area of opening at the vocal cords. Thus, the vocal cords open and the airflow increases in velocity, the cords move to closure and the airflow decreases, the cords close completely together, and no air flows.

The investigators reviewed an ARAC search and are looking closely at two of the references sent.

PROBLEM UW-51: Bladder Electrodes

Victims of paralysis of the lower extremities have no control of urine voiding. The investigator is conducting research on dogs in the area of electrical stimulation of in vivo bladders to facilitate the mechanism of voiding urine at a preset time. The investigator needs electrodes to attach to nerves of an in vivo bladder. Present electrodes used in this research have been unsatisfactory due to increase of interstitial fibrous tissue after repeated stimulations. The electrodes must be miniature, flexible ribbon type that are biologically inert.

Through manual searching, an article was found of possible relevance.

PROBLEM UW-52: Bladder Stimulator

Victims of paralysis of the lower extremities have no control of urine voiding. The investigator is conducting research on dogs in the area of electrical stimulation of in vivo bladders to facilitate the mechanisms of voiding urine at a preset time. The investigator needs an external wireless electronic device to deliver a variable electrical charge to an implanted sensor to stimulate the bladder.

Manual searching was performed for applicable devices.

PROBLEM UW-57: Means to Detect Center of Gravity in a Walking Man

The design and development of powered artificial limbs require an extensive understanding of those forces generated by normal and artificial limbs during walking and some other activities requiring the use of these limbs. Of particular interest to this investigator are the linear (X, Y, and Z vectors) forces generated during these movements. He seeks information about a vertical reference system to detect the angular position of a walking man with respect to earth to determine the center of gravity. A miniature vertical gyro or pendulum is desired.

Two documents were requested by the investigator from the results of an ARAC search. The investigator evaluated these documents as having useful equations for data reduction.

The investigator also requested help in locating transducers to make the measurements and two sample industrial units were sent to him. These transducers worked very well. The manufacturer was contacted by the BA Team and he agreed to furnish \$200 worth of transducers at no cost to further work on this project.

PROBLEM UW-59: Foot Force Measurement

During recovery from fractures of various bones in the leg or from surgical procedures to correct leg and foot deformities, it is desirable to have the patient gradually resume weightbearing while still in a cast. This is done by having the patient walk while supporting part of his weight on crutches. Unfortunately, it is difficult to accurately estimate the maximum load actually borne by the leg in this situation. If a crushable metal heelplate could be mounted on the bottom of the patient's cast, the orthopedic surgeon could determine whether or not the patient exceeded the specified load during partial weightbearing by examination of the heelplate. The heelplates should crush at specified loads ranging from approximately 10-25 lb.

Three documents were requested from an ARAC search. None appear to be directly helpful to the investigator.

PROBLEM UCPA-1: Self Propelled Wheelchair

The Cerebral Palsy Association deals with individuals who are severely handicapped and confined to a wheelchair. Many of these persons depend entirely upon another person to move them about their house. The major manufacturer of wheelchairs produces an electric-drive wheelchair for about \$900. This wheelchair folds as does a standard wheelchair, but weighs about 100 lb. Both the high cost and heavy weight are objectionable. Motors, components and batteries which are lighter and more efficient are needed for designing a better powered wheelchair.

An ARAC and manual search was run and the results evaluated. Some components were identified with better characteristics, but were of prohibitive cost.

PROBLEM UCPA-2: Wheelchair Transport

Handicapped persons who are confined to a wheelchair encounter extreme difficulties in traveling around the city or attending rehabilitation facilities and social or work activities. Public transportation shuns these people and private vehicles are incompatible to their needs. Consequently, most of these people remain shut-ins and depend upon others for their support.

The United Cerebral Palsy Association uses a small van to transport persons confined to a wheelchair while they are in the chair. The driver, frequently a volunteer, loads the van by rolling the person in the wheelchair up a long inclined plane and then straps it to the floor. A strong man is needed to accomplish this task.

An improved procedure for placing the wheelchair and occupant in the van, and securing the chair is needed. The procedure must be easy enough for a woman to accomplish, and inexpensive to implement.

An ARAC and manual search was run and no directly applicable systems were found.

A search of commercial equipment was made and two applicable systems found. The investigator has not been able to obtain a unit yet because of lack of funds.

PROBLEM WMMH-1: Automatic Blood Pressure Measurement

The investigator is working in the area of psychophysiological therapy with hypertensive patients. The objective of the research is to teach these people to voluntarily lower their blood pressure through proper conditioning. The patient's blood pressure is displayed to him while he is working to lower it. This procedure is termed "on-line visual feedback." A device is needed which will automatically sense arterial blood pressure and display it to the subject. The device requirements are: Non-invasive, automatic, continuous measurement or repetitive with periodicity not greater than 30 sec/measurement, and visual display of systolic and diastolic arterial pressure (50-300 mm Hg).

A search of NASA data was made and no applicable data found.

PROBLEM KU-48: Local Pressurized Oxygen Applicator

Because oxygen, under high pressure, creates a powerful inhibitory environment for bacteria, suppressing their growth, it has been widely used in the treatment of decubitus ulcers, infected lacerations, and meningomyeloceles. This treatment, however, requires the use of expensive large hyperbaric chambers. The investigator would like a device which could seal only the area under treatment and expose this area to hyperbaric oxygen.

A manual search was started. We have found that Dr. B. H. Fischer of the New York University School of Medicine has constructed such a device.

PROBLEM KU-50: Prolonged Limitation of Mobility

Spinal cord injuries and cardiovascular diseases are illnesses which require confinement to bed for long periods of time. During this confinement "deconditioning" of the cardiovascular system usually occurs, which is characterized by the occurrence of orthostatic hypotension.

Since similar observations have been made in astronauts after prolonged spaceflight, the investigator feels that NASA may have data which could assist in the rational management of "deconditioned" patients.

Manual and computer searches were started. A document (TTF-639) was found which describes a controlled study of strict bed confinement.

ARTIFICIAL ORGANS

PROBLEM IU-37: Encapsulation of Electronics

As more electronic devices are becoming available for implantation in human patients to correct or monitor physiological functions, it is desirable that these devices last as long as possible before replacement is required. The investigator is convinced that the major cause of device deterioration and failure is the leakage of body fluids into the device by corrosion around the lead connections. The total prevention of leakage would help in the prediction of device life and to prevent unexpected device malfunction that in some cases, such as a heart pacemaker, could cause the death of the patient.

A computer search was made and several relevant documents sent to the investigator. One document N70-25502 was particularly applicable.

PROBLEM WU-4: Carbon Implant Materials

Pure carbon has been shown to have advantageous characteristics for in vivo medical use. Carbon is an attractive material for implanted prosthesis because of its properties of high compressive strength; anti-thrombosis; chemical, biological, and physical compatibility with body fluids and tissues; and ease of sterilization. However, methods are needed for carbon coating materials which have good flexibility and tensile strength, and for forming carbon into solid shapes or tubes for replacement of diseased or destroyed tissues.

Carbon appears to be a good thromboresistant agent. Studies have indicated that carbon per se has a strong affinity for quaternary ammonium compounds which, in turn, bind heparin, an antithrombic agent. Highly purified carbon alone seems to exert a thromboresistant effect. Since anti-thrombosis is essential for prostheses which must enclose or transmit blood or accept tissue growth, the development of carbon materials for human implantation is of extreme importance and benefit to patients with cardiovascular diseases. Efforts to construct an artificial heart have intensified the search for thromboresistant materials during the last few years.

Methods are needed for forming, weaving, coating, and otherwise manufacturing materials composed of carbon for use in artificial hearts, heart valves, and blood vessels.

An ARAC search was run and yielded 106 abstracts. Several documents have been sent to the investigator and appear to be relevant to the problem.

PROBLEM WU-7: Biocompatible Materials

New materials are desperately needed for the construction of membranes, flexible sacks for artificial hearts, and flexible leaflets for prosthetic valves. A search for polymers which can be used in construction of prosthetic devices is the objective of this research program. It is desirable to set up a biomaterials program to specify and test materials for implants and prosthetic devices. High flexibility, extended fatigue life, and long-term in vivo compatibility are the specifications of the needed materials.

The availability of materials that are biologically compatible with the human body and medically approved is limited. The development of new materials has been plagued by the viewpoint that one material should be all things at once. This viewpoint is changing. During the past several years, compounded materials have been explored with the result that polymeric materials appear to have distinct benefits in superior fatigue life and thromboresistance.

The investigator has indicated that several of the documents sent him have possible future application.

ORGAN ASSIST DEVICES

PROBLEM IU-53: Miniaturized Heat Exchanger

Organ preservation is important to the viability of organ transplantation. Medical researchers and practitioners would like to preserve an organ in a functional state for 24 hr or longer. Several organ preservation systems are available but are not acceptable because of their large size and weight which precludes their use over long distances. One such system for kidney transplants uses the principle of dynamic perfusion (forcing fluids through the organ) at low temperatures. The investigator believes that components of this system could be reduced in size. One miniaturized component needed is a heat exchanger to maintain a constant temperature in the system.

An ARAC search was run and the results were forwarded to the investigator. He is now evaluating the abstracts.

PROBLEM IU-54: Miniaturized Oxygenator

Organ preservation is important to the viability of organ transplantation. Medical researchers and practitioners would like to preserve an organ in a functional state for 24 hr or longer. Several organ preservation systems are available but are not acceptable because of their large size and weight which precludes their use over long distances. One such system for kidney transplants uses the principle of dynamic perfusion (forcing fluids through the organ) at low temperatures. The investigator believes that components of this system could be reduced in size. One miniaturized component needed is a membrane oxygenator that is open to air and uses varying concentrations of oxygen.

An ARAC search was run and the results forwarded to the investigator. He is in the process of evaluating the abstracts at the present time.

PROBLEM IU-55: Miniaturized Pulsatile Pump

Organ preservation is important to the viability of organ transplantation. Medical researchers and practitioners would like to preserve an organ in a functional state for 24 hr or longer. Several organ preservation systems are available but are not acceptable because of their large size and weight which precludes their use over long distances. One such system for kidney transplants uses the principle of dynamic perfusion (forcing fluids through the organ) at low temperatures. The investigator believes that components of this system could be reduced in size. One miniaturized component needed is a pulsatile pump which can be programmed to deliver an adjustable volume at specific intervals.

An ARAC search was run and the results sent to the investigator. A reference was found describing the army artificial heart. The investigator is attempting to get one of these pumps to evaluate.

PROBLEM UM-100: Charging System to Prolong the Life of Ni-Cad Batteries

The investigator has built a proportional control hand prosthetic device that is powered by rechargeable Ni-Cad batteries. He was having battery failures and he feels that these failures and the resulting short battery lives are caused by improper recharging. Manufacturers of the batteries had been contacted and they could offer no data or better charging systems.

The NASA document SP-172 was forwarded to the investigator. He used procedures and charging systems recommended for increasing the life of Ni-Cad batteries as described in the document.

PROBLEM UM-118: Biotelemetry

The investigator is working with patients who do not have normal control of the bladder due to nerve damage. He is building nerve impulse simulators that will generate bladder expulsion stimulation but he also needs some way to monitor the bladder to tell how full it is. He feels that a passive telemetry system might have merit since no power sources would need to be implanted.

An ARAC search was run and forwarded to the investigator. He is presently evaluating the results of this search.

PROBLEM UM-120: Implantable Flexible Electrodes

The investigator is doing research on the simulation of nerve impulses. He is doing work with persons that have bladder control difficulty due to nerve damage. He is implanting electronic impulse simulators and needs electrodes to connect the electronics to the bladder. When the bladder expels, there is considerable movement and the present electrode leads tend to break because of mechanical stress and fatigue. More flexible electrodes are required.

An ARAC search was run on this problem and forwarded to the investigator. The information on the flexible electrodes made at Ames Research Center was also sent along with the search results and is now being evaluated.

PROBLEM UM-121: Implantable Encapsulation of Electronics

The investigator is doing research on simulation of nerve impulses. He is working with persons that have difficulty controlling the bladder retention and expulsion due to nerve damage. He is attempting to simulate the nerve impulses by electronic means. The electronic circuits that are required to simulate these impulses will be implanted in the body for long periods (5-10 yr).

Previous searches on encapsulation of electronics were reviewed and relevant documents are being evaluated by the investigator.

PROBLEM UM-130: Current Measurement to a Nonlinear Load

The investigator is using rechargeable batteries in a prosthetic device and wanted to be able to measure the amount of power taken from the batteries while the patient is doing normal activities. This information was needed to better understand the battery requirements for the device.

A manual search was done of aerospace data and a possible solution was found in TN D-5773. This was evaluated as applicable by the investigator and the circuit was incorporated into the prosthetic device power supply.

MENTAL HEALTH

PROBLEM UM-58: Low Surface Energy Materials

Mental retardation and serious brain damage can result from brain compression due to hydrocephalus, a condition in which excessive cerebrospinal fluid is produced. Researchers are seeking methods to correct the abnormally large production of cerebrospinal fluid in some humans. Present treatments use plastic valve systems called shunts, commonly placed from the lateral cerebral ventricle (a cavity in the brain), into the right atrium (an upper chamber of the heart) via the internal jugular vein in the neck. There are two problems with these shunting devices, traced to the catheters (miniature flexible tubings inserted into veins, etc.) employed. The atrial catheter commonly collects a thrombus (clot) which either occludes the catheter or eventually leads to thrombosis of the venous system. The ventricular catheter is often enmeshed by the choroid plexus (a frond-like cellular structure) which produces the cerebrospinal fluid. One plastic valve system available for the treatment of this disease is impregnated with heparin, which suppresses blood clotting.

The investigator believes tubings made of low surface energy materials, such as fluorinated silicone, may repel red blood cells and the choroid plexus due to the tubing developing negative charges in these environments. This could prevent these two major complications attending plastic valve shunt treatment of hydrocephalus. The investigator is interested in obtaining information on low surface energy materials developed in the space program which may be applicable to this problem.

Reports on project THROMBUS were found using an ARAC search and the investigator was put in contact with suppliers of described materials. He is presently having shunts constructed using that material.

PROBLEM PSH-1: Transducers for Ergometer

Three percent of the children in the United States are mentally retarded. These children are attaining higher mental levels than believed possible 10 yr ago, as a result of special care and therapy in institutions such as the state hospital and training center for mentally retarded children in Parsons, Kansas. Most of this success stems from the increased emphasis on physical therapy programs aimed primarily at improving muscular

coordination. It is now apparent that the mental capacity of these children increases proportionally with their muscular coordination, and that the earlier these programs are started, the higher the mental level these children attain.

Dr. Neis has worked with the mentally retarded for 20 yr. He has developed techniques, using equipment of his design, to measure coordination working muscles. Preliminary observations indicate that his techniques can detect borderline retardation at 1 yr, which would normally go undetected for several years until sophisticated motor and mental capacities could be tested. In his studies, he has developed an instrument with which we can test the coordination of the hands and feet in motion around circular sprockets. He now needs transducers and ancillary equipment for continuously measuring the amount and direction of pressure exerted by these extremities.

A manual search was made of aerospace information to locate unique transducers for this application. No data were found on instrumentation that would be better than that commercially available. MRI is now attempting to aid the investigator in using commercial equipment and in locating funding for the construction of an instrumented prototype.

HEART DISEASE DETECTION AND TREATMENT

PROBLEM IU-69: Negative Body Pressure

The investigator is starting a research program and wanted systems to provide negative body pressure. This problem has not been completely defined and no searching done.

PROBLEM UM-19: Intercardiac Transducer

The investigator needs a very small transducer to measure heart sounds and pressures inside the heart. The transducer must be small enough to be inserted into a No. 7 French Catheter after it has been put in place. The transducer length should be no more than 1 cm and the diameter no more than 1 mm. The tunnel diode transducer developed by the Electronics Research Center, Cambridge, Massachusetts, and described in Technical Note C-87 meets the requirements.

The transducers are now available on the commercial market; however, they have not been tested sufficiently to be recommended for human use. As soon as they have been proven safe the investigator will evaluate them for heart sound monitoring applications.

PROBLEM UM-128: Human Heart Volume Measurements

A means is needed to measure the volume of the human heart in time. Patients with cardiac problems sometimes have a catheter inserted into the heart. The catheter injects a radio-opaque contrast medium into the heart. The heart is then silhouetted on a radiation-sensitive surface, and the brightness of the image is intensified with an electronic image intensifier. The output image goes through a beam splitter. A TV camera scans the output image, and the output of the camera appears on a TV monitor. The other half of the split beam is photographed by a movie camera. One possible method of solution is to record the analog signal from the TV camera, digitize it, and process.

The work that NASA has done on digital processing of photographs may have applications here and this information is being made available to the investigator.

PROBLEM UM-142: Four Channel EEG Recorder

Investigator has been referred to commercial sources for this equipment.

PROBLEM UM-143: Detection of Bio-generated Magnetic Fields

The objective of the investigation is to monitor the magnetic field variations generated by electrical cardiac activity. Magnetic measuring techniques do not require the attachment of electrodes to the body and thereby circumvent the problems associated with electrical grounding of patients and with electrochemical changes at the tissue-electrode interface producing artifactual signals. The graphic traces obtained with the magnetic method are expected to contain the same information as in electrocardiography (ECG).

The investigator has submitted a proposal to the NASA TU Office for funding by one of the NASA centers.

PROBLEM MU-45: Automated Servo Systems

The researcher's objective is to construct and evaluate an automated system for infusing lidocaine into myocardial infarct patients. The physiological responses of the patient are fed back to an IV pump to regulate the drip rate according to the specific needs of the individual. The feedback signal will be derived from the patient's ECG to control the drip rate. One familiar example is servo-anesthesia in which the patient's brain waves indicate his level of anesthesia which, in turn, controls administration rate of anesthetic. A servo system is needed to automatically

control infusing rate of lidocaine using physiological response in the feedback loop.

An ARAC search yielded 20 documents of which two were requested by the investigator. These have been forwarded to him.

PROBLEM MU-47: Methods for Automatically Monitoring Arrhythmias

A technique is needed for automatically detecting arrhythmias, specifically ventricular ectopic beats. The incidence of irregular heart beats will actuate a servo system to administer drugs to counteract irregularities. The investigator feels that the ECG and blood pressure waveforms contain sufficient information to identify an arrhythmic condition. The technique should distinguish abnormal QRS wave from T-wave or movement artifact, be low cost, and be self contained without elaborate facilities.

A manual search was performed yielding five documents requested by the investigator. These are currently being evaluated.

PROBLEM WU-3: Mechanical Stresses in Aortic Valves

It is desirable to fabricate an artificial aortic valve for a human heart which duplicates the mechanics of the normal valve. The normal aortic valve is composed of three leaflets which come together to close a circular opening. The leaflets are flexible and flap open and closed on each heart beat, nearly 40 million times per year. To design and evaluate a prosthetic tri-leaflet valve which can withstand many years of complex flexure, the dynamic stress-strain relationship must be known. A computer program or analytical technique is needed to determine these dynamic stresses in the leaflets of an aortic valve.

An ARAC search produced many good documents on both stress analysis and aorta blood flow. The search has been forwarded to the investigator and evaluated as "excellent and helpful in design phase of project." The investigator has forwarded a proposal to the NASA TU Office for funding.

PROBLEM WU-6: Measurement of Cardiac Chamber Volume

The investigator desires a rapid means of measuring the dynamic change of the cardiac chamber volume from fluoroscopic or similar techniques. Fair estimates of cardiac chamber volume have been accomplished using cine-fluorography or cineradiography, but such measurements are slow and cumbersome. These techniques require days of processing and evaluation. A rapid conversion to digital form and interface with on-line computing facilities would permit continuous real-time evaluation of dynamic changes of cardiac chamber volume. This capability would permit preoperative visual evaluation of myocardial contractility, which would be a significant improvement in diagnosis.

The investigator evaluated an ARAC search as: "A few references highly pertinent to present project." Additional information searching is being carried out.

PROBLEM WU-16: Cardiac Output Measurement

The researcher is investigating the cardiac output of normal subjects performing moderate activity, such as encountered in daily activities. Instrumentation to monitor cardiac output without restraining or annoying the subject is required. The system should be for long-term application (days); human use; invasive or non-invasive method; non-confining; leads permissible.

Eight documents were found by manual searching and have been supplied to the investigator. He has evaluated them as being of potential value.

PROBLEM SL-2: Correction of Physiological Pressure Measurements

Fluid-filled, remote-reading manometers are the most frequently used method of measuring physiological pressures. They are relatively simple, safe, inexpensive, and versatile (injection and sampling). However, an important disadvantage is the distortion of the shape of the pressure pulse by the thin bore tubing (catheter). This distortion is particularly serious, for instance, when trying to compute the rate of change of pressure with respect to time (dP/dt) or when attempting to measure the difference of maximum pressure (ΔP) between two catheter-tip locations. (dP/dt may be used as a measure of strength of ventricular contraction; ΔP may be used to determine the extent of aortic valve malfunction.) Catheter characteristics vary from type to type and from size to size. Within one type and size, there are variations from one catheter to the next. Therefore, a simple method of calibration is needed.

A sinusoidal pressure generator developed by Dr. Stegall at Brooks under NASA Contract T-37761-G was identified as a contribution to this problem. It has been built and is in use by the investigator in his clinical laboratory.

ECOLOGY

PROBLEM UW-60: Transducers and Transmitters for Fish for Underwater Pollution Research

The pollution problem in the Great Lakes has been one of much recent concern. Polluted water and fish taken from these waters are a major health hazard. The investigator is currently measuring environmental factors, including pollution, which influence free roaming fish. Experiments have been conducted using ultrasonic transmitters to transmit temperatures from within fish. However, devices are needed to measure tail movements, depth, and water temperature. They will be used in Lake Michigan, Lake Mendota, and in Alaskan waters. Information will be obtained to determine (1) the mechanisms used by fish for guidance in returning home from open water, and (2) the responses of fish to polluted waters.

A manual search has been conducted but no directly applicable systems have been found.

HEALTH CARE COST REDUCTION

PROBLEM UM-96: Computer Data File System Design

and

PROBLEM UM-97: Computer Data File Management

The investigator desires information on the design of a computer system that will handle large data files of patient records. This includes storage and retrieval of patient records. Ultimately, the desire is to perfect techniques for handling patient records in any major hospital. The hospital has sophisticated data processing equipment, but lacks the ability to handle a large data system. It is hoped that information storage and retrieval systems devised by NASA can be adapted to fit the needs of a medical facility.

~~An ARAC search was run and several abstracts were of interest to the investigator. The most applicable system was MEDATA and he is presently evaluating documentation on it.~~

PROBLEM WU-21: Digital Display of ICU Patient Parameters

The investigator needs a method for displaying numerous selectable patient parameters through an intensive care unit in digital form. An electronic monitoring system is being designed for an intensive care unit (ICU) at Barnes Hospital. Plans call for the use of conventional medical transducers and amplifiers to collect patient parameters. These parameters are arterial blood pressure, ECG, central venous pressure, temperature, respiratory flow and pressure, and blood gas concentrations; they appear as analog signals. The signals will be processed by a dedicated digital computer which will calculate derived patient data, compare patient data with assigned limits, and generate output for a near real-time display system. Displays will be placed in strategic locations about the ICU. Any patient can be selected for monitoring. The system requirements are: minimum of three digit readout; patient and parameter selectability, and economical CCTV monitors will be used for analog data display. The two displays could be combined if economy permits.

An ARAC search produced 48 documents and has been sent to the investigator for evaluation.

PROBLEM WU-22: Video Display of Analog Waveshapes

The investigator needs a video display to present five real-time analog waveshapes in graphical form for intensive care unit displays. An electronic monitoring system is being designed for an intensive care unit (ICU) at Barnes Hospital. Numerous patient parameters will be monitored from each patient, and these parameters will be processed by a dedicated digital computer to calculate derived parameters and to signal the onset of dangerous conditions. Two of these parameters, ECG and arterial blood pressure, must be displayed in graphical form and in real-time. In addition, three base-line graphs will be generated by the computer and displayed graphically. A relatively large number of displays are required for viewing from various locations in and around the ICU. The display system should have sufficient resolution and proper sweep time to display ECG and blood pressure signals accurately and in real-time; and low cost per display.

The investigator has been sent a computer search with 123 abstracts.

PROBLEM KCH-2: Pharmaceutical Inventory System

The investigator needs a computerized system for efficiently controlling supplies of pharmaceuticals. The ordering of pharmaceuticals by subjective opinion and counting can create an oversupply of some drugs while forgetting to order others. The investigators work under a tight financial budget. Drugs needlessly ordered cause overextensions in budgetary outlays.

The hospital has a supply of approximately 1,000 drugs and these supplies cannot remain on the shelf more than 6 months. An efficient computer inventory system is required.

An ARAC search was run with few relevant documents. A computer program from MSC for transistors showed promise, but final documentation of the program was not received.

REMOTE HEALTH CARE SERVICES

PROBLEM UM-57: Physiological Monitoring

A plan and cost analysis has been done in Freeborn and Mower counties, Minnesota, for the planning and demonstration of improved patient care. One phase of the study was to examine the uses of new technology as a productive approach to improving accessibility to health professional services and to minimize the penalty of a shortage of scarce professional resources. It was felt that the work NASA has done in monitoring the astronauts may be applicable in some cases to the proposed remote patient monitoring.

ARAC computer searches were run on the problem and thirty-four (34) documents were requested of which nineteen (19) were used in the study.

PROBLEM UM-80: Computer Data Collection

It is essential that sophisticated therapy be provided in rural areas even though the local physicians have no specialized training. In medical fields such as nephrology (kidney disorders) computers could be used to assist in surveillance of the medical, financial, and rehabilitation aspects of dialysis patients so that therapy could be provided to rural patients. Information is needed on how to obtain trend analysis of biochemical data on a large number of patients being maintained in a regional chronic hemodialysis program.

An ARAC and manual search was run on this problem. The MEDATA program was evaluated as having possible application and is being evaluated for that purpose at the present time.

PROBLEM MU-49: TELEMED

The Space Sciences Research Center has a contract with NASA to develop hardware for a remote health care system for diagnosis and screening of rural citizens. The project, titled TELEMED, is to define and specify a system for providing lab tests and diagnostic services by paramedical personnel on-site and for telemetering certain data to a central, full-service hospital for diagnosis by the staff. The system will provide

medical aid where doctors' services are scarce or not available. Topics of interest include: blood and urine chemical analysis, automatic ECG reading, ECG recording and transmission, signal multiplexing, spirometry, interocular pressure, hearing and eye tests, automatic transduction of physiological parameters. Methods are needed for providing remote health care services using paramedical personnel, automated instrumentation, and data links to a central diagnostic hospital. State-of-the-art instrumentation and systems are required.

One ARAC search on the general topics has been initiated. Other documents of interest found manually have been forwarded to the investigator.

REDUCTION OF INFANT MORTALITY

PROBLEM UM-79: Intracranial Pressure

The investigator has been performing measurements of the intracranial pressure of infants by measuring the force required to depress the diaphragm across the anterior fontanelle. She is using an instrument that was originally designed to measure the internal pressure of the eye. This instrument is a mechanical device and has the disadvantage that it must be used in a vertical position. She needs an electronic transducer system to make these measurements in any position.

A manual search was made on this problem and the blood pressure transducer described in N62-13733 appeared to have some desired characteristics. A similar transducer was obtained and used to make some measurements. There is still some difficulty in correlating the measurements with the electrical system and the investigator continues to work on the problem.

PROBLEM UM-122: Implantable Miniature Pump

Hydrocephalus is a common chronic condition in infants caused by excessive pressure of cranial fluid. The investigator is constructing a cerebrospinal fluid by-pass system for hydrocephalus infants. Systems currently in use have pumps located outside the body of the patient. These systems have problems of (1) infection, and (2) lack of mobility for the infant. He believes an electrical pump could be implanted in the abdominal part of the body of these infants, which would drain the excess fluid through other tubing from the brain into the abdominal cavity. He is interested in power sources, motors, pump parts, and pressure activated control systems.

An ARAC search was run and forwarded to the investigator for evaluation. Also information on a commercial unit was sent to him.

PROBLEM UM-129: Stethoscope for Use in High Noise Environment

The investigator has a mobile infant care van that is used to transport critically ill infants from outlying areas into the University Hospital. The infants must be monitored during transporting. The operation of the van engine and traffic cause considerable noise inside the van and the use of a regular stethoscope is difficult. A unit that is not so susceptible to ambient noise is needed.

Documentation on such a stethoscope was found in a manual search. The device had been built at Brooks AFB and an attempt was made to obtain a unit for evaluation. It was learned that the original design was being modified and no units were available.

PROBLEM UM-135: Nonclogging Monitoring Catheter

The investigator is developing a computer controlled pediatric extensive care monitoring system. One of the data inputs is blood pressure from the umbilical artery. This pressure is obtained using a short (12-in.) arterial catheter. The catheters that are presently being used are quick to clog due to clotting and blood pressure signals are lost giving false alarms and incorrect data. A new design or material or both are needed for a non-clogging catheter.

An article appeared in the January 1971, Aeronautics and Space Report of the President to Congress about advanced research on electrically charged polymers which might have potential in the development of nonclotting tubing for blood transport. This is being followed up on to locate where the work is being done and to see if it is applicable.

Information on these materials and addresses of manufacturers were located and forwarded to the investigator.

PROBLEM UW-48: Tissue Flow Meter

Tissue-cellular levels of oxygen in infants can be used following therapeutic measures to determine their efficiency (or harm). Similarly, flow rates of blood through tissue in infants are not examined in disorders such as hyperinsulinism (excess insulin in the body, decrease of sugar in the blood) where suspected fluctuations in levels may occur. The investigator is currently working on measuring these flow rates to determine possible harmful levels of oxygen and/or blood. This requires a tissue flowmeter which would be applied to an infant's foot.

A manual search on this problem was performed. No aerospace related information has been identified.

PROBLEM UW-54: Miniature Heart Rate Sensing Devices

The investigator is conducting research on ewes (female sheep). Chronic indwelling catheters have been maintained in umbilical vessels of these animals for repeated measurements of heart rate in the umbilical blood. Measurements of other physiological parameters have been carried out on human fetuses by obtaining samples of blood from the scalp. The investigator wants an improved combination system: a miniaturized device to be implanted under the scalp of the fetus in the uterus in experimental animals to monitor heart rate by telemetry. Eventually, this system could be used in humans.

A manual search was made and no relevant data were found.

PROBLEM UW-55: Miniature Blood Pressure Sensing Devices

The investigator is conducting research on ewes (female sheep). Chronic indwelling catheters have been maintained in umbilical vessels of these animals for repeated measurements of blood pressure in the umbilical blood. Measurements of other physiological parameters have been carried out on human fetuses by obtaining samples of blood from the scalp. The investigator wants an improved combination system: a miniaturized device to be implanted under the scalp of the fetus in the uterus in experimental animals to monitor blood pressure by telemetry. Eventually, this system could be used in humans.

A manual search was made and no relevant data found.

PROBLEM UW-56: Miniature pO₂ Sensing Devices

The investigator is conducting research on ewes (female sheep). Chronic indwelling catheters have been maintained in umbilical vessels of these animals for repeated measurements of pO₂ in the umbilical blood. Measurements have also been carried out on human fetuses by obtaining samples of blood from the scalp. The investigator wants an improved combination system--a miniaturized device to be implanted under the scalp of the fetus in the uterus in experimental animals to monitor pO₂ by telemetry. Eventually, this system could be used in humans.

A computer search was run and no relevant data found.

RESPIRATORY DISEASE DETECTION AND TREATMENT

PROBLEM IU-58: Airflow Meter with Low Resistance

The investigator is doing metabolic studies using exercising dogs. The respiration is being monitored and one of the parameters that will be measured is airflow. A flow meter is needed that will offer a minimum resistance to air movement.

An ARAC search was run and the results forwarded to the investigator. A Tech Brief and supplemental information on a flow meter designed originally for STOL Aircraft was also sent the investigator. The data are now being evaluated.

PROBLEM UM-33: Pulmonary Instrument

The investigator wishes to study the effects of environment, infection and treatment on the pulmonary function of a mammal that has bronchial glands comparable to man. Instrumentation is needed to study the pulmonary function in small mammals such as rats.

The investigator is interested in the mass spectrometer systems used by NASA such as the MIRACLE II system and wants to observe it when it is in operation. It is scheduled to be available in the first part of 1971.

The investigator did not think the MIRACLE II would have sufficient sensitivity for his experiments.

PROBLEM UM-92: Respiratory Analysis

The ability of a mass spectrometer to provide continuous (simultaneous or quasi-simultaneous) analysis of multiple gases during respiration would make possible a new order of studies in pulmonary physiology. Background on existing techniques and equipment is needed to begin work in this field. The investigator is compiling information on existing technology for back up information for writing proposals for research grants. This requires the most recent and comprehensive technological information.

~~An ARAC computer and manual search was run on this problem. Information was found on the MIRACLE II NASA system that appeared to have the required specification. Arrangements were made for the investigator to see the system, but there were difficulties with the equipment and it was returned to the vendor before he could see it in operation. As soon as it is again available he wants to see it in operation.~~

PROBLEM UM-95: Low Dead Space Breathing Mask

Of the volume of air taken in by inspiration, about 150 cc remain in the nose, trachea, bronchi, etc., where no exchange of gases takes place. This is called "dead space." The investigator is trying to perform breath-to-breath analysis, without cross mixing of air. He is presently using a "low dead space" sampling device which fits in the mouth; however, this device is uncomfortable to the patients. The investigator needs a mask-type apparatus with only a small residual air space. The apparatus would be attached to a mass spectrometer to provide analysis of the multiple gases during respiration. This would make possible a new order of studies in pulmonary physiology. The volume of air to be analyzed would average about 150 cc while a frequency of 13-18 breaths/min is usually maintained.

An ARAC search was run and the results sent to the investigator. He considered several documents applicable.

IMPROVED SURGICAL PROCEDURES

PROBLEM UM-63: Implantable Materials and Lubricants

In some severe cases of arthritis, the cartilage that lubricates skeletal joints has been damaged or diminished to the extent that the use of the joint is lost. Arthritic damage to this degree in joints involved in locomotion--such as hip joints--cripples the sufferer. The investigator seeks a lubricant that can be injected between arthritis-damaged joints to replace or assist the damaged cartilage. He also seeks specialized materials that could firmly cover skeletal joint bearing surfaces in arthritic cases where artificial cartilage or other lubricants cannot be applied.

An ARAC and manual search was run on this problem. Documentation on work done at the Lewis Research Center Lubrication Lab was found that was relevant. The investigator went to Lewis and presented the problem to the lubrication people. He is now communicating with them in an attempt to collaborate in finding a solution.

PROBLEM UM-115: Implantable Time Capsule

~~Hemophilia is a hereditary disorder characterized by delayed~~ clotting of the blood. Hemophiliacs, consequently, have difficulty in controlling hemorrhage even after minor injuries. Bleeding can be stopped by the injection of plasma fraction directly into the bloodstream. However, this treatment requires hospitalization and repeated injections. The investigator is interested in constructing an implantable capsule to release the plasma fraction at a predetermined rate for about a week.

An ARAC computer search was run and no relevant information was found.

PROBLEM UM-131: Wound Coverings

Workers in meat packing plants cutting up the carcasses of slaughtered animals work with sharp tools and are susceptible to cuts through accidents. These wounds must be protected from water and animal body fluids after they have been dressed to prevent infection from the surroundings and from the carcasses on which they are working. At present, rubber gloves are being used as protection devices but when these are worn for long periods of time, the moisture from the limb itself is trapped inside. The skin cannot breathe and begins to deteriorate. A material is needed that will keep the water and animal body fluids out of the wound and at the same time allow the covered area to "breathe" normally.

An ARAC search was run and evaluated by the investigator. He considered six documents to be relevant and is now evaluating them.

PROBLEM UW-30: Portable Refrigeration System for Use as a Surgical Tool

A surgical technique utilizes refrigeration anesthesia during leg operations. The technique employs a double-walled, water-filled boot with attendant refrigeration system to reduce the temperature of the damaged leg. The technique has been successfully used on over a dozen amputation patients, and has been extended to the treatment of athletic injuries. A portable refrigeration unit is needed for cooling the fluid in this boot. The unit should possess a capacity of 1/20 ton (600 Btu/hr), lightweight (25 lb or less), and portable. It must meet the safety requirements of hospital operating rooms.

Relevant documents were sent to the investigator and are still being evaluated for potential use.

PROBLEM WU-5: Clean Room Technology

Wound infection and sequelae remain a serious surgical complication. Operating rooms with sterile atmospheres can be expected to reduce such infections. Clean room techniques employing a laminar flow system offer an important advancement for operating room sterility. The investigator desired detailed information on laminar flow systems applicable to operating rooms.

An ARAC search produced 46 documents and was evaluated as "excellent material--provides sufficient information for proper evaluation of laminar flow and clean room technology to properly design renovation for present open-heart operating room and new rooms to be built." A transfer

on this problem was finalized in September 1970, and follow-up documentation has been produced during this contract period.

The new operating room is now in operation and a Biomedical Applications Bulletin published.

PROBLEM KU-35: Flow Meter for Respiration Measurement

During surgical anesthesia, it is essential that the respiratory state of the patient be under continuous observation. The patient is connected to a closed circuit anesthesia machine in which the machine gas flow directly represents patient flow. The gas composition may vary considerably as the anesthetist varies the anesthetic mixture. It may contain appreciable concentrations of halogenated hydrocarbons or explosive mixtures. The researcher needs a respiration volume flowmeter to be used during surgery that is sensitive to flows in the range of ± 5 liters/sec.

NASA TN D-4234 offers a potential solution to this problem. A modified Wright spirometer has been delivered to the investigator.

PROBLEM KU-49: Abrasive for Bone Removal

A miniature sandblaster is used in ear operations to remove bone tissue. The abrasive material is aluminum oxide in the form of a powder, particle size being about 25 μ . The orifice of the blasting tool is 1 mm in diameter. Aluminum oxide is a good abrasive, but it is difficult to completely wash away. This metallic particle residue can be harmful to the tissues if it is not completely removed. A hard, soluble particle is needed to replace the aluminum oxide particles.

A manual search was made to locate possible abrasives that are soluble in water, alcohol or other harmless liquid capable of being ground into a fine powder with particle size of about 25 μ . None have been found at this time.

PROBLEM MCGH-3: Current Limiting Circuit

Electroanesthesia (EA) holds great promise for animal and human surgery, particularly for procedures in which drugs cannot be tolerated. Sances (1965) and Short (1967) have shown that diffuse, time-changing electric currents applied transcranially through external electrodes can produce unresponsiveness in experimental animals permitting major surgical operations.

The portable electrical anesthesia generator presently under development incorporates silver-zinc batteries that must be charged at 2 volts per cell at a rate of 2 amperes. A voltage source regulated at the desired open circuit voltage would draw more than 2 amperes when connected to the discharged battery. Therefore, a current limiter is required to prevent damaging the batteries.

NASA Tech Brief 70-10232 describes a 2-terminal current limiter which has been incorporated in the portable electroanesthesia generator.

PROBLEM IMH-1: Clean Operating Room

An Indiana hospital wanted to build a vertical laminar flow operating room for orthopedic surgery. Estimates and plans from commercial firms were unsatisfactory, so the hospital began designing their own operating room. They experienced considerable difficulty in obtaining specifications for this installation.

The hospital asked our BA Team for NASA information on clean rooms. When their plans were ready two members of the BA Team visited the hospital and suggested several changes. This clean operating room is presently under construction.

PROBLEM IMH-2: Hospital Bacteria Counting System

An Indiana hospital is building a laminar flow operating room. One of their major problems is the best method for the real-time monitoring of airborne bacteria. Current methods involve the use of a particle counter and culture techniques. Particle counting is fast but does not reflect the number of airborne bacteria. Culture techniques are slow (24-48 hr/determination), not too accurate, but qualitative. The surgeons need a device which will count the number of bacteria in an air sample and identify its species.

A manual search of NASA technology yielded two partial solutions. Both were developed for life detection on Mars; one measures $C^{14}O_2$ production from C^{14} glucose and the other ATP (the major energy source necessary for life). Evaluation of these systems showed that the ATP system could give real time quantitation of airborne bacteria if its sensitivity could be increased 100-fold. Ways to do this are being sought.

PROBLEM CRS-1: Anti-Fog Agent for Surgical Mask

An anti-fog agent was needed that could be applied to the inside of a plastic bubble surgical mask to prevent it from fogging over, causing a decrease in visibility.

The anti-fog agent as described in Tech Brief 71-10149 was made and sent to the investigator for evaluation and worked satisfactorily.

PROBLEM CRS-2: Audio Communicator

The use of "clean rooms" in the surgery suite and complete isolation garments for the personnel has made direct communication between the operating team difficult. A communication system is needed that will give direct voice communication and will not compromise the isolation capabilities of the protective clothing.

The audio transceiver described in NASA Tech Brief 70-10335 appears to have application. Mr. Cribbs at KSC is interested in building prototype units to be evaluated under actual conditions. Dr. Bechtol has agreed to evaluate the unit.

DENTAL AND ORAL DISORDERS DETECTION AND TREATMENT

PROBLEM UM-56: Cleft Palate Airflow Measurement

Current treatment of cleft palates in children requires accurate measurements of air emitted from their nostrils during speech. These measurements reveal changes in the palate's fissure history, response to treatment, and other characteristics. The measuring device must not alter the normal nasal airflow of the child by restricting nasal passages. However, previous tests indicate reasonably accurate airflow measurements can be made with one nostril blocked. Apparatus that either disturbs the child or makes him uncomfortable can be responsible for inaccurate measurements.

An ARAC computer search and manual search was made on the problem. The device described in B68-10438 was considered to have value as a portable clinical tool for gross measurements. One of these devices was constructed and sent to the investigator, and he is presently evaluating it.

PROBLEM CU-6: Ultraminiature Cardiac Manometer

The treatment of oral diseases required an improved understanding of the mechanics of oral biological systems. This particular problem concerns the mechanics of operation of salivary glands. The investigator seeks recently generated measurement data and instrumentation that measure the secretion of fluids and electrolytes from these glands. His investigations indicate a hydrostatic pressure component may be generated across the secretory epithelium (membrane over glandular cavity), by the intraglandular vascular pressure to produce the secretions. The investigator needs to be able to

measure the intraglandular vascular pressure during blood outflow and glandular secretion measurements that are made when arterial inflow to area of the gland is stopped. The investigator has noted a very close correlation between the durations of blood outflow and secretion when the arterial inflow is interrupted.

Three documents were found in aerospace-generated technology that offer potential solutions to this problem. Additional documentation has been forwarded to the investigator.

PROBLEM UMKC-5: Electropotential of Tooth Nerve

The prevention and treatment of dental diseases can be enhanced by the development of methods to detect affected teeth in the early stages of the disease. One of many attacks on this problem involves the detection of electric potential changes of a nerve within the pulp of an individual tooth. This early detection principle is based on the premise that dental nerves respond to irritation in a manner similar to sensor nerves in other body tissues. There is presently no instrument commercially available to measure electrical potentials in a tooth.

A problem statement was distributed in March 1970. One possibly pertinent problem response has been received during this contract period.

BASIC RESEARCH PROBLEMS

PROBLEM IU-59: Body Heat Regulation

The investigator is establishing an exercise laboratory to study body heat regulation of the exercising human in high temperature environments. He would like information on systems to measure external and internal temperatures of the body. Telemetry systems might be applicable.

An ARAC search was run on the problem and evaluated by the investigator. Ten relevant documents are now being evaluated.

PROBLEM IU-60: Body Sweat Regulation

The investigator is establishing an exercise laboratory to study ~~body sweat regulation of exercising humans in high temperature environments.~~ He would like information on sweat measuring devices and telemetry systems to process this signal.

An ARAC search has been run on this problem and is being evaluated by the investigator.

PROBLEM IU-61: Heat Tolerance

The investigator would like to have a testing system that would measure heat tolerance of exercising human subjects. These subjects will be trained and evaluated in a high temperature environment.

An ARAC search was run and sent to the investigator for evaluation.

PROBLEM IU-62: Heat Acclimatization

The investigator would like to have a testing system that would reliably determine the heat acclimatization of human subjects. These subjects will be trained and evaluated in high temperature environments.

An ARAC search was run and is being evaluated by the investigator.

PROBLEM IU-63: Method to Measure 2,3 DPG of the Blood During Exercise

The investigator is studying heat acclimatization of humans. He needs a way to monitor the 2,3 DPG of blood during programmed exercise. It is desirable not to require the drawing of blood. If blood must be taken, it is desirable to have as short a processing time as possible.

A manual search was made and no applicable NASA data were found.

PROBLEM IU-64: Method to Measure the Shift of Body Fluids During Exercise

Blood flow to liver, kidney, and gastrointestinal tract is progressively reduced as man performs work of increasing intensity. During work in the heat, blood flow to these organs is reduced even more. The investigator is interested in the redistribution of blood flow between the deep veins, the superficial veins, and the intramuscular veins of active and inactive limbs in response to physical exercise in varying environments. For example, if a man performs leg exercise, how is blood distributed between these veins in the working legs compared with the inactive arms? In recovery from such exercise, how is blood distributed between these veins?

A manual search was made of NASA data and none were found that were applicable.

PROBLEM IU-67: Hot Wire Anemometers for Air Volume Flows

The investigator is doing experiments on metabolism using respiration rate and oxygen consumption as a measured parameter. He needs flowmeters to measure air volumes. He is presently using rotometer type devices and would like a meter with faster response that would read on a remote indicator.

Commercial equipment was located and specification sheets sent to the investigator.

PROBLEM IU-68: Bone Growth Detection

The investigator is studying bone growth in small animals (rats). These animals are injected with dyes of different colors during the growth period and then sacrificed and cross-sections of the bone evaluated as to percent of bone containing the specific colors. He needs instrumentation to scan the bone cross-section and read out the percent stained each individual color.

A manual search was made and no applicable NASA data found.

PROBLEM UM-113: EKG Telemetry System for Active Worker

Persistent daily rhythms or cycles occur in a number of physiological variables in many living organisms. Dr. Runge at the University of Minnesota is interested in determining changes in these cycles caused by switching time zones. A system is needed to obtain telemetric EKG data on time zone effects on active humans.

A search was made of NASA data to locate applicable systems.

PROBLEM UM-114: Portable Respiration Analyzer for Active Worker

Persistent daily rhythms or cycles occur in a number of physiological variables in many living organisms. Dr. Runge at the University of Minnesota is interested in determining changes in these cycles caused by switching time zones. A system is needed automatically to monitor the respiration of an active human to obtain reliable data on time zone effects.

A manual search was made and the reports on the NASA quadrupole mass spectrometer mounted in a flight helmet were sent to the investigator for evaluation.

PROBLEM UM-119: Magnetic Impulse Detector

The investigator is doing research in detection of abnormal nerve impulses and simulation of nerve impulses. He would like to detect nerve impulses by detecting the magnetic fields generated by ionic movement in the body. Work has been done with this type of detection around the head and heart where activity is very high and well-understood. This investigator wants to scan other parts of the body to see if impulses can be detected and abnormalities discovered.

An ARAC search was run on this problem and forwarded to the investigator for evaluation. The problem was also presented to researchers at Ames Research Center and the investigator is corresponding with the magnetics laboratory there.

PROBLEM UM-123: Mass Spectrometer Computer Interface

The investigator has a mass spectrometer that he is using to analyze data and other complex lipids. He has funds to obtain a small computer to connect to the spectrometer to process this data, but does not have trained personnel to help him choose the best type of computer and the way the interface should be assembled. He will also be needing computer programs that would be applicable.

An ARAC search was run to obtain computer programs and sent for his evaluation. He was also put in touch with a computer programmer at MRI to assist him.

PROBLEM UM-124: Hyperbaric Chamber Design

The investigator is interested in building a chamber to house experimental animals (pigs) at increased pressure for long periods of time. He wants the chamber to be in two sections so one-half can be cleaned while the other holds the animal under pressure. He is also interested in accessory equipment for the chamber to control its pressure, temperature, humidity, etc.

An ARAC search was run on this problem and forwarded to the investigator for evaluation.

PROBLEM UM-125: Blood Sampling in a Hyperbaric Chamber

The investigator is going to do lipid studies on experimental animals, mini pigs, in high pressure environments. The pressures will be up to 60 atmospheres and he does not want to have to decompress the animal during sampling. The restraint of the animal must be gentle so as not to

excite him excessively causing artifacts in the test results. The testing will be conducted over long periods of about 90 days and a blood sample of about 100 cc will be taken every third day.

Manual searching of aerospace information is being done to find possible relevant data and systems.

PROBLEM UM-133: Dry Electrodes

The investigator is working on the development of a computer controlled intensive care monitoring system. One of the monitored signals is the EKG. There are electrodes on the market that are usable to collect these signals but they are not ideal. The investigator would like to have a dry electrode that could be attached to the patient easily, would be comfortable and have low movement artifacts.

Previous searches on electrodes were reviewed and applicable data sent him. Also the development of dry electrodes at Ames Research Center is being monitored as having possible application.

PROBLEM UM-137: Microcalorimetry of Cells

The investigator is studying the differences between malignant and normal body cells. He feels that the heat generated by the cells may be different and needs a system to measure the heat generated by the cells very accurately.

An ARAC search was run and several relevant documents found. The information in document N63-19132 is being used in the design of a heat burst instrument.

PROBLEM UM-138: Microbeam Laser

The investigator is studying the cell membrane and the transport across it. He wants to produce small holes through the membrane to observe changes in the transport mechanism. A low power laser is needed with a very small beam that will puncture the membrane but otherwise not damage the cell.

An ARAC search was run and two relevant documents found. Information in A65-13711 showed that the proposed approach was infeasible without extensive ossification.

PROBLEM UM-140: Survival of Biological Cells in Vacuum

The investigator is studying cell membrane transport and wants to expose some cells to X-ray and electron beams as a way to make very small punctures in the membrane without damage to the rest of the cell. He would

like to expose these cells in a vacuum and needs a cell or spore that can survive such an environment.

An ARAC search was run and relevant documents were found. One document contained research on the ability of cells to withstand high vacuums. At least one, and probably several microorganisms named in the report will be used by the investigator.

PROBLEM UM-141: Thermo-Osmosis

Thermo-osmosis is the movement of mass across a membrane (for instance, water from the interior to the exterior of a cell) which is caused by a temperature gradient. Several authors have claimed that thermo-osmosis does not exist in biological systems. An investigator at the University of Minnesota believes that thermo-osmosis does occur across biological membranes and has developed a model system to test his hypothesis.

An ARAC search was made and many relevant documents found. Information from documents N67-31766, N63-18959, N67-19346, N66-18236, N64-11357, and N64-30391 will be used by the investigator in his work.

PROBLEM UW-58: Solid-State Light Detector

The fields of medicine and microbiology have need of improved instrumentation and techniques for simultaneous measurements of the volume of living cells and the amount of artificially induced fluorescent stain they have absorbed. This instrumentation could benefit such tasks as cell sorting, the study of cell reproduction, cancer cell identification, red and white corpuscle counting, and many others. The investigator is attempting to build such instrumentation. The system requires a low level radiation detector (5,000-6,000 Å) to detect the fluorescent light output from a single cell as it passes by the end of a fiber optic.

One document was requested by the investigator from an ARAC search and evaluated as "useful in designing fiber optic systems." The information from this document is also being used for student education. This problem has been reported as an "impact."

PROBLEM MU-44: Physiological Effects of Magnetic Fields

The researcher is conducting research on low-level bioelectric control mechanisms involved in growth and regeneration of tissue and organisms. To enhance the research he is extending the studies to the effects of magnetic fields. Data are needed on the effects of magnetic fields on physiological changes in mammals. Notable effects are desired for short and long term periods; field strengths higher and lower than earth's (~ 2/3 gauss).

An ARAC search was run which yielded 13 citations.

PROBLEM KU-42: Measurement of Body Vibrations

The investigator is attempting to assess human vibration sensitivity, both psychologically and physiologically. Vibrations of the environment of only a few thousandths of an inch in the frequency range of about 3 to 15 Hz cause psychological and physiological distress in the human being. Psychological, because the individual is either unaware of the vibration or unable to identify its source; physiological, because the vibration affects the body's organs. Tests are to be performed on humans and experimental animals to determine where and how humans sense vibrations, and to discover how small vibrations affect humans psychologically. Acceleration levels of 0.1 to 0.2 g's in excess of normal gravity will be applied to the subjects at several amplitudes and frequencies. External measurements will be made on various parts of the body, e.g., the head, the sternum, the extremities. In animals accelerations of various internal organs will be measured. Obviously, small size and weight are important, but specific maximum dimensions have not been restricted.

The investigator has obtained a triaxial accelerometer and it seems to be just what he needs. It has the proper sensitivity frequency response, and size characteristics.

PROBLEM SL-4: Semi-Permanent Blood Sampling System

The investigator desires a technique to sample blood continuously during critical periods. Such a method would allow immediate feedback on the effect of drugs being administered so that the amounts could be varied accordingly.

The method must be able to remain in place for many hours without clotting or causing excessive contraction of the host vessel.

Aerospace literature was reviewed and no relevant data found.

PROBLEM MCGH-2: Cortical Mapping of Visual System Projections

The investigator is studying the feasibility of stimulating the visual cortex by the implantation of electrodes. The aim of the study is to eventually develop a visual prosthesis for the blind. The investigator was aware of NASA sponsored information in this area and requested it. An ARAC search produced several important documents which are being used to modify the experiments. In particular, a monkey brain atlas prepared for NASA has been very useful in the placement of electrodes in various areas of the brain.

PROBLEM MRI-1: Air Shower for Rodent Quarters

The infection of a rat colony by plueropneumonia-like organisms (PPLO) jeopardizes most toxicological evaluations by producing lesions that obscure the interpretation of drug effects. Recognizing this problem, major rat breeders have developed expensive special breeding facilities and shipping containers so that investigators can receive pathogen-free animals. Upon receipt, these animals are usually isolated from other rats, which only lessens the incidence of PPLO. Two probable sources of infection are the transmission of organisms through ventilation systems and the transporting of organisms on the clothes of animal caretakers.

An isolation room has been utilized in the MRI rodent facilities using an air wash lock at the entrance, and was designed using NASA data.

PROBLEM UN-13: FM Telemetry

A vital function study will be made of hibernating ground squirrels. A "cold box" will be used to house the animal and this box will be stored in a suitable refrigerated room. The animals will, of course, be inactive during hibernation and during this time the transmitter will be attached to the animal. Body temperature and heart rate information will be monitored during hibernation and during the period when the animal is waking.

The NASA SP-5094 document on telemetry was sent to the investigator and contained schematics of applicable circuits.

PROBLEM UN-14: Implantable Transmitter

The resistance change of the strain gauge will be used to modulate the r-f carrier of the transmitter. The transmitter will be the implantable type and needs to be very small. The size should not exceed 1/2 cu. in. if possible. The range of the transmitter is noncritical, and a self-contained antenna would be desirable.

The NASA SP-5094 document on telemetry was sent to the investigator and contained applicable circuits.

OTHER, MISCELLANEOUS

PROBLEM IU-51: A System to Make Holograms of Falling Bodies (Animal)

The investigator is studying body control and balance mechanics of animals. A method is needed to observe and analyze limb locations in three dimensions. One method proposed is to make a rapid sequence of holograms of falling bodies. Information is needed on the most recent technological developments concerning holograms and on the design of such a system.

An ARAC computer search was run and forwarded to the investigator. He identified relevant documents and they were obtained and sent to him. He is now evaluating these documents.

PROBLEM IU-65: Blood Pressure Measurements in Small Dogs

The investigator needs a way to accurately measure the blood pressure of puppies over a period of several months. Presently, the only sufficiently accurate method he has found is by using a catheter. He would like to make the same measurements without having to make an intrusion.

A manual search was made of aerospace data and no relevant data were found.

PROBLEM IU-66: Pressure-Controlled Perfusion Pump

The investigator is studying blood circulation in teeth. One experiment requires that a latex be pumped into the localized circulatory system at a constant pressure. He needs a liquid pump or variable speed motor that is controlled by discharge pressure.

A manual search was made of aerospace data and no applicable document found.

PROBLEM UM-84: Physiologic and Hematologic Response

The investigator has been attempting prolonged ex vivo organ perfusion on dogs. This involves restraining the dogs for long periods of time. Marked red cell changes and gastrointestinal and respiratory effects were observed in the course of the experiment. The investigator would like to know if these responses have been noted in other experiments involving prolonged restraint and, if so, what studies have been done to obtain physiological data. The investigator wants to obtain data which might have some influence on the parameters of his experiment.

PROBLEM UCPA-3: Human Waste Management for the Handicapped

Persons afflicted with cerebral palsy sometimes have difficulty controlling the processes of urination and defecation. This can be a serious social and psychological problem for the individual, particularly during group rehabilitation classes.

A search was made of NASA documentation and some applicable data found. A Hydro-john unit was obtained and given to the investigator. He is presently evaluating the device and attempting to interest the manufacturer in constructing a specialized unit.

PROBLEM MU-48: Integrated Circuit Amplifiers

The investigator wishes to incorporate an amplifier in implantable pressure and force transducers used in biological measurements. The integrated circuit amplifier would actually become a portion of a semiconductor sensor, deposited on or adjacent to the substrate. The purpose of the amplifier is to increase signal strength and reduce interference and losses due to low level signal transmission over long leads between sensor and amplifier. The investigator needs designs and techniques of designing integrated circuit amplifiers for biological transducers. This should include circuit design; fabrication techniques including masking, evaporative deposition and etching.

Results of a computer search are being evaluated by the investigator.

PROBLEM SL-1: Management Information Center

St. Luke's is a teaching hospital that presently runs training programs for nurses (student and in-service), x-ray technicians, practical nurses, medical technologists, aids and orderlies, interns, resident MD's, medical students, pharmacy students including such specialized courses as operation of intensive care centers. In addition, St. Luke's will be one of the backup hospitals for the new UMKC Medical School. They desire a training room to have a combination of audio-visual, closed circuit TV, display surfaces, and devices to allow the most effective training of medical personnel.

A plan was developed based on one of the candidate locations and has been technically accepted by both the associate administrators and the investigator. The plan utilized the designs and specifications for display devices, rear screens and equipment from the Sky Lab/Space Shuttle Management Center at MSC, furnished by Mr. Leo Zbanek, Deputy Chief Engineer, Manned Spacecraft Center.

PROBLEM KCH-1: Computerized Medical Surveys

The investigators are obtaining inpatient data from 30 Kansas City area hospitals for medical surveys. These data include addresses, diagnosis and billing data. Data for approximately 150,000 patients will be gathered in a year. The investigators have the capabilities of graphically displaying these data in several forms, but cannot easily retrieve desired sets of information from their data tapes.

One of the investigators attended the MEDATA seminar held at MRI on 12 January 1971. He believes that the MEDATA program will be very useful to his problem in the batch processing form. NASA document N68-27549 and MSC documentation on the program was supplied the investigators. A magnetic tape listing of the source program has been received from MSC and been available to the investigator.

PROBLEM MRI-2: Methyl Alcohol Fuel Cell

A fuel cell is being developed for private industry as a component of a system. The system and its use are confidential at present.

DISTRIBUTION LIST

Final Report, Contract No. NASW-1936, MRI Project No. 3332-E(D)

Mr. Jeffrey Hamilton
Director
Technology Utilization Division
Office of Industry Affairs and Technology
Utilization
NASA Headquarters
Washington, D. C. 20546 (1 copy)

Chief, Technology Applications Branch
Technology Utilization Division
Code KT (Mr. James T. Richards, Jr.)
NASA Headquarters
Washington, D. C. 20546 (4 copies)

Technical Reports Control Officer
(Code US)
Scientific and Technical Information
Division
NASA Headquarters
Washington, D. C. 20546 (6 copies)

Scientific and Technical Information
Facility
Attn: NASA Representative
P.O. Box 33
College Park, Maryland 20740 (2 copies including
camera-ready copy)

Head
Industrial Economics Division
Denver Research Institute
Denver, Colorado 80210 (1 copy)

Charles W. Shilling, M.D.
The George Washington University
Biological Sciences Communication Project
2001 S-Street, N.W. (Suite-200)
Washington, D. C. 20009 (3 copies)

DISTRIBUTION LIST (Continued)

Mr. Brad Evans
Technology Utilization Officer
Mail Stop N-240-2
Ames Research Center
Moffett Field
Mountain View, California 94035 (1 copy)

Mr. James W. Wiggins
Technology Utilization Officer
Code A&TS-TU
George C. Marshall Space Flight Center
Huntsville, Alabama 35812 (1 copy)

Mr. Sam Synder
Technology Utilization Officer
Mail Stop F-309
Space Nuclear Propulsion Office
Technology Utilization Branch
U.S.A.E.C. Building
Washington, D. C. 20545 (1 copy)

Mr. Clinton T. Johnson
Technology Utilization Officer
Box 273
Flight Research Center
Edwards, California 93523 (1 copy)

Mr. Donald S. Friedman
Technology Utilization Officer
Code 207.1
Goddard Space Flight Center
Greenbelt, Maryland 20771 (1 copy)

Mr. John C. Drane
Technology Utilization Officer
NASA Pasadena Office
4800 Oak Grove Drive
Pasadena, California 91103 (1 copy)

Mr. James O. Harrell
Technology Utilization Officer
Code AD-PAT
John F. Kennedy Space Center
Kennedy Space Center, Florida 32899 (1 copy)

DISTRIBUTION LIST (Concluded)

Mr. John Samos
Technology Utilization Officer
Langley Research Center
Mail Stop 103
Hampton, Virginia 23365 (1 copy)

Mr. Paul Foster
Technology Utilization Officer
Lewis Research Center
Mail Stop 3-19
21000 Brookpark Road
Cleveland, Ohio 44135 (1 copy)

Mr. John T. Wheeler
Technology Utilization Officer
Code BM7
Manned Spacecraft Center
Houston, Texas 77058 (1 copy)

Mr. J. Chris Floyd
Technology Utilization Officer
Code AMD-S0
Building F6
Wallops Station
Wallops Island, Virginia 23337 (1 copy)

Dr. F. Thomas Wooten, Director
RTI Biomedical Applications Team
Research Triangle Institute
P.O. Box 12194
Research Triangle Park, North Carolina 27709 (1 copy)

Dr. David F. Culclasure, Director
Biomedical Applications Team
Southwest Research Institute
8500 Culebra Road
San Antonio, Texas 78228 (1 copy)

Mr. Harry Miller
Stanford University School of Medicine
Cardiology Division
701 Welch Road, Suite 3303
Palo Alto, California 94304 (1 copy)

Dr. Michael McCartney
Division of Biomedical Engineering
University of Virginia Medical Center
Box 224
Charlottesville, Virginia 22901 (1 copy)