

072-25317

REMOTE DETECTION OF CAT BY INFRARED RADIATION

Robert W. Astheimer

Barnes Engineering Company

Several years ago, it was established by the work of P. W. Kadlec of Eastern Airlines (Project TRAPCAT, Ref. 1), that clear air turbulence was frequently associated with temperature gradients or discontinuities in the atmosphere. Barnes Engineering Company had just completed the development of the Satellite Infrared Spectrometer (SIRS) for the Weather Bureau for remote atmospheric temperature probing and it occurred to us that this technique might be adapted for the remote detection of CAT. To investigate this possibility an experimental airborne scanning infrared spectrometer was built under company sponsorship.

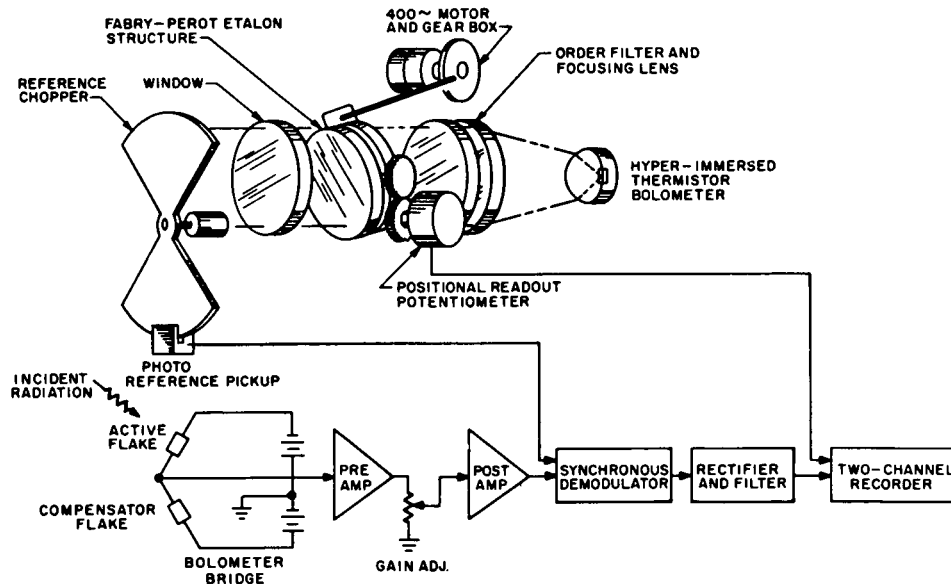

Figure 1 Fabry-Perot Spectrometer Optical-Electronic Schematic

A schematic drawing of this instrument is shown in Figure 1. It is essentially a Fabry-Perot interferometer with a narrow field of view directed along the flight path of the aircraft. The spectral bandwidth was 0.3μ and by rocking the Fabry-Perot etalon a spectral scan was obtained over the wing of

REMOTE DETECTION OF CAT BY INFRARED RADIATION

the 15μ CO_2 absorption band. Distant temperature variations could be detected by comparing the signal received in a spectral region of low absorption with those in a high absorption region, the latter being an indication of the near or local air temperature which is used as a reference.

In the winter of 1966-7 a flight evaluation program using this instrument was funded by the FAA. The flights were conducted by the National Aeronautical Establishment of the National Research Council of Canada, using a T-33 Aircraft which was specially instrumented for turbulence measurements.

The results of these flight tests (Ref. 2) indicated a very high correlation between turbulence and temperature changes, and remote detection was obtained at distances up to about 10 miles. The instrument, however, was found to be extremely sensitive to pitch and only data taken when the aircraft was in very stable flight was useable.

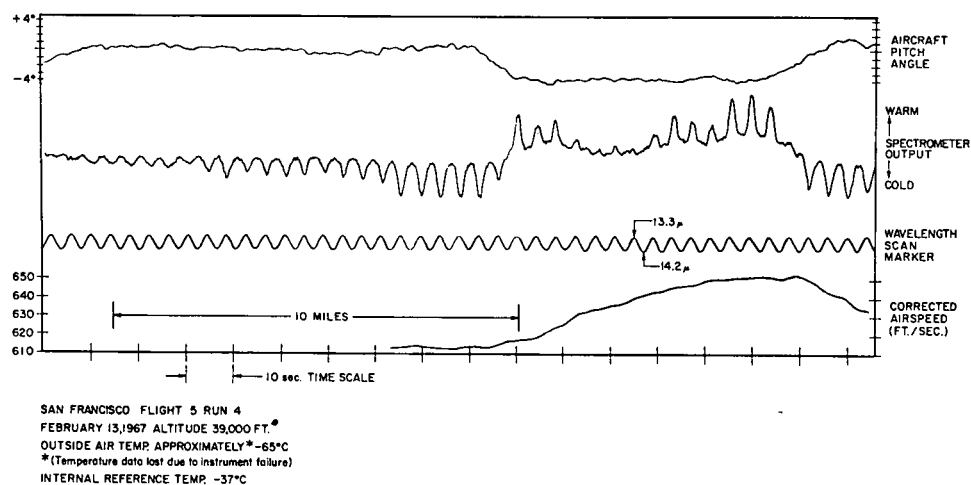

Figure 2 Sample Record Obtained with Fabry-Perot Spectrometer

Figure 2 shows one of the few records obtained where a turbulence encounter was preceded by a reasonably pitch-free period, so that the spectrometer record was not contaminated by pitch signals. The spectrometer output is a cyclic signal produced by the spectral scan, which was at the rate of 2 scans/second. When the temperature is uniform for a long distance ahead of the aircraft the spectrometer output remains constant over the spectral scan. As the turbulent region is approached, the associated temperature discontinuity is first sensed at the low absorption region of the spectral scan. This produces a 2 cps output which grows as the distance to the temperature anomaly shortens. It will be seen that the turbulence encounter in Figure 2 is first detected at a distance of about 10 miles. The spectrometer output after the turbulent region is entered is of no significance because of aircraft pitching.

Sensitivity to pitch is to be expected since when pitched down, the distant air viewed will be at a lower altitude and hence warmer than the local air and conversely when pitched up. However, the magnitude of the effect was much larger than expected. It was found that pitch changes of 0.2° would produce signals as large as a change in air temperature of about 1°C at a distance of 20 miles. It was concluded that a practical instrument would have to be pitch stabilized to better than $\pm 0.2^\circ$ to avoid an unacceptable false alarm rate.

It also appeared from these flights that a continuous spectral scan was not necessary and that alternately sampling two bands was sufficient, one band in a region of high absorption indicating local air temperature, and the other band in a region of low absorption to sense distant air temperature with respect to the local air temperature reference. This would permit considerable simplification of the instrument and also increase the sensitivity since the electronic bandwidth could be reduced.

In 1967 a simplified instrument was constructed on these principles. A sketch of it is shown in Figure 3. The radiation is chopped by a wheel consisting of two filter sectors, one with a passband centered at the peak of the absorption band, and the other in a region on the wing of the band. The amplitude of the chopped signal is then proportional to the difference in radiation between the two spectral regions. This carrier is amplified, synchronously rectified, filtered and recorded as a slowly varying DC signal. When the air temperature is constant for a long distance ahead of the aircraft the radiation will be the same in the two bands and the output will be zero. A distant temperature anomaly will first appear in the filter on the wing of the band to produce a difference signal and hence a small DC output, which will increase as the anomaly is approached.

The field of view is 1° high and 4° wide. It is directed horizontally along the flight path of the aircraft and pitch stabilized to $\pm 0.2^\circ$ by a 45° mirror which is servo controlled from the aircraft's vertical gyro reference. The receiver head was designed to be interchangeable with a sextant airlock fitting which is installed on the cockpit roof on many modern jet aircraft. Thus it can be conveniently mounted without cutting any metal on the aircraft.

CAT can extend horizontally over 50 miles or more, but is usually localized vertically to within a few thousand feet. This suggests that a change in altitude may be the best avoidance maneuver, and that a vertical search mode may be desirable. Since the instrument already has the servo-driven, pitch stabilizing mirror, it is easy to program this for a vertical search mode. A $\pm 3^\circ$ vertical scan, with respect to the horizontal reference has been provided. A plot of the output normally to be expected with this scan is shown in Figure 4. The lapse rate of the atmosphere should produce a monotonic temperature increase as the scan moves downward. A turbulent zone might appear as "bump" or irregularity on this smooth curve as suggested in the figure.

REMOTE DETECTION OF CAT BY INFRARED RADIATION

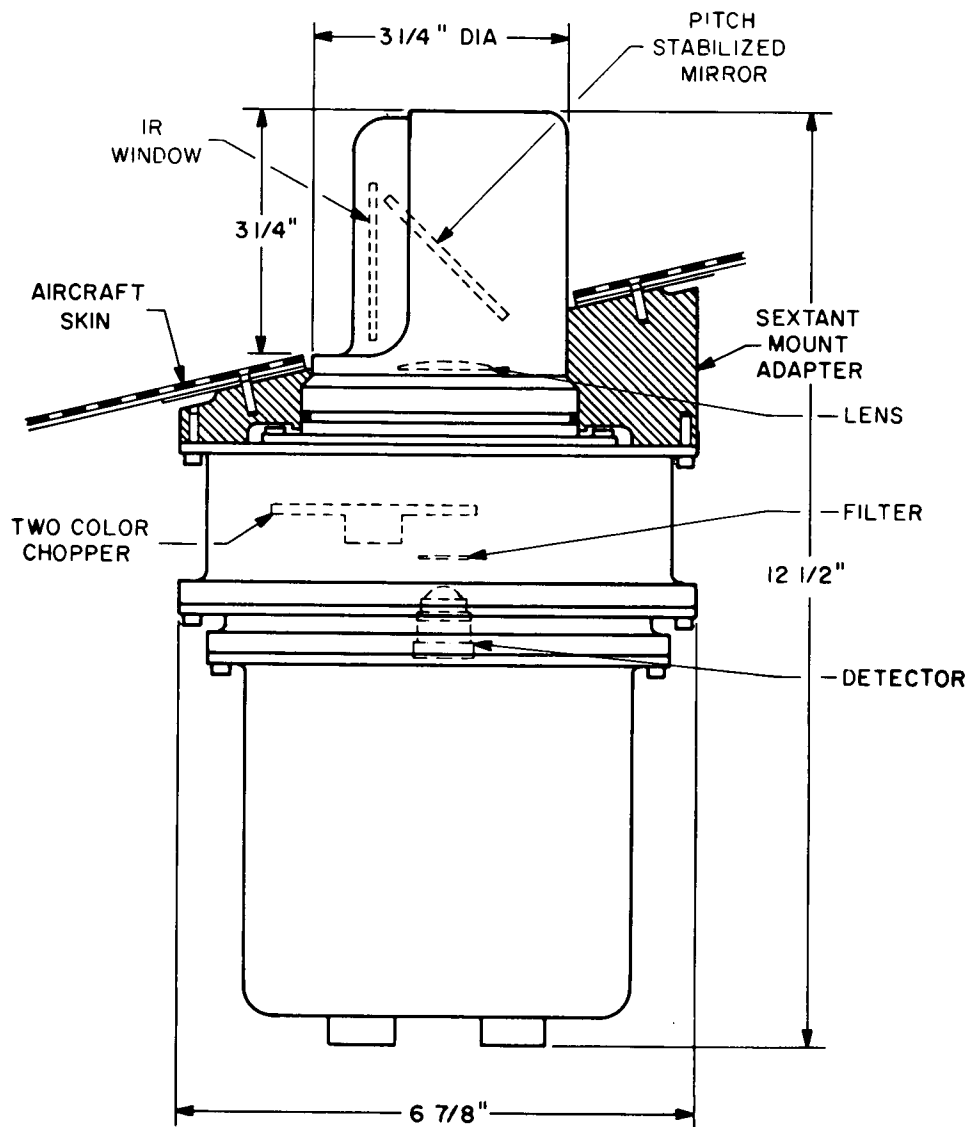

A1158-012

Figure 3 IRCAT Sensor Head

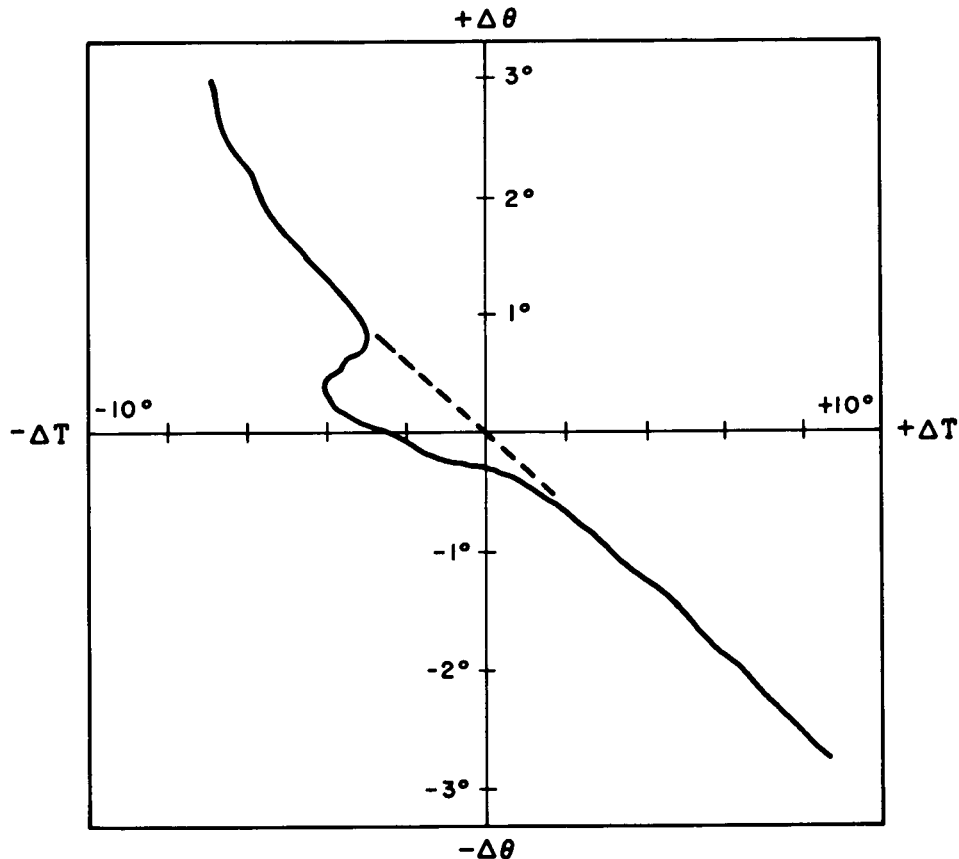

Figure 4 Vertical Search Mode Display

This instrument, which has been dubbed "IRCAT" was installed in the Canadian Research Council's T-33 and flown in the Denver area during February and March of 1968. Unfortunately, at least as far as instrument evaluation was concerned, no CAT was encountered. However, it was found that even with the line of sight stabilized, the residual pitch errors of less than $\pm 0.2^\circ$ still produced disturbing signals.

The remaining pitch sensitivity is believed to be caused by the choice of spectral band, for the wing (or "far") filter. Figure 5 shows the transmission along a horizontal air path at 38,000 ft. for a variety of spectral bands. The contribution to signal of any distant slab of air is proportional to the difference in transmission between the two boundaries, which in the limit for an infinitesimally thick slab becomes the derivative of the transmission curve, known as the weighting function. We wish to optimize detection for the 20 - 40 mile interval. The difference in transmission or weighting function for this interval is shown in Figure 6 as a function of center wavelength for 1μ wide

REMOTE DETECTION OF CAT BY INFRARED RADIATION

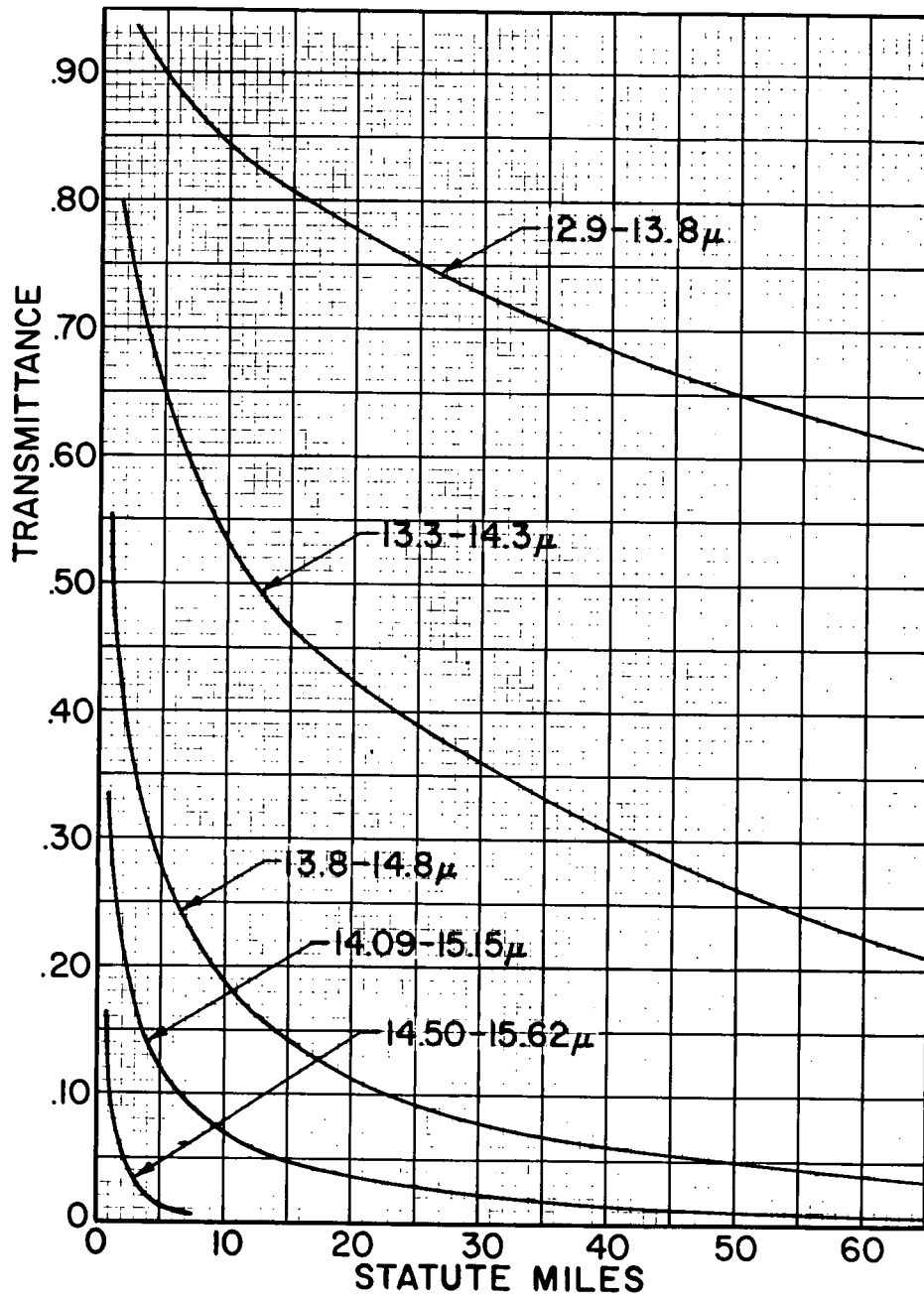

Figure 5 Horizontal Transmission of the Atmosphere at 38,000 Ft. Altitude

bandpasses, and for altitudes of 18K and 38K. A center wavelength of 13.4μ (actually $12.9 - 13.8$) had been chosen as a good compromise over this altitude range.

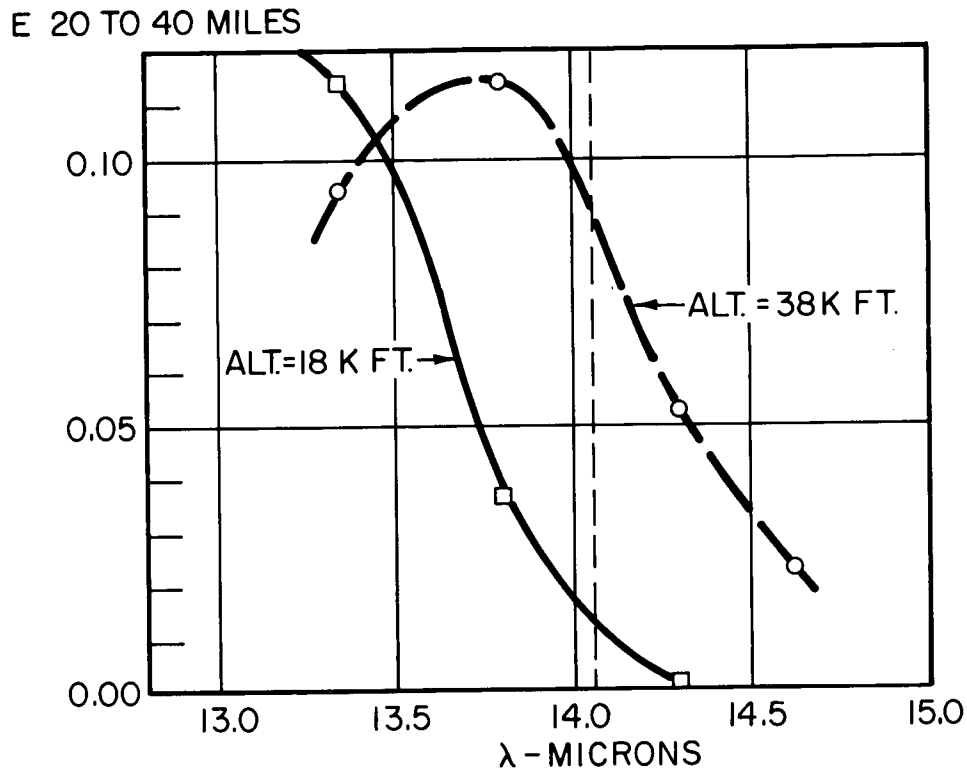

Figure 6 Effective Emissivity of a Slab of Air Extending from 20 to 40 Miles

However if we look at the transmission of this spectral region in Figure 5, we find that 68% of our signal comes from the air beyond 40 miles and 60% beyond 70 miles. Thus we were sensing mostly the very distant air, and because of the curvature of the earth are actually looking through the atmosphere, out to space. This long "lever arm" would be expected to make the signal highly sensitive to pitch.

To eliminate this condition the "far" spectral bandpass has been shifted to a center wavelength of 14.1μ where the absorption of CO_2 is stronger. This will not cause much loss in sensitivity to temperature discontinuities in the 20 to 40 mile range as can be seen from Figure 6, but it will greatly reduce the contribution of the air beyond 40 miles. This spectral bandwidth will give degraded performance at low altitudes, but since long distance jet flights usually cruise at altitudes between 30K and 40K feet, it seems best to optimize the spectral region for this altitude range.

REMOTE DETECTION OF CAT BY INFRARED RADIATION

This filter has now been installed and will be evaluated on the T-33. Also additional IRCAT instruments are under construction for evaluation by three major airlines to begin later this year.

REFERENCES

1. Kadlec, P. W., Feb. 1966, "Exploration of the Relationship between Atmospheric Temperature Change and CAT," ION and SAE Conference on CAT, Washington, D. C.
2. Mather, G. K., May 1967, "Flight Evaluation of an Infrared Spectrometer as a CAT Detector," National Research Council of Canada, Nat. Aero. Establishment Ottawa Aeronautical Report LR 477.

SESSION 8

Crossed Beam
Correlation
Techniques