

PSU-IRL-SCI 392(E)



THE PENNSYLVANIA
STATE UNIVERSITY

N72-26120

IONOSPHERIC RESEARCH

Scientific Report 392(E)

A UNIQUE MODULATION SYSTEM FOR
TWO CHANNEL DATA TRANSMISSION

by

Bruce Thorne Melrose

May 15, 1972

**CASE FILE
COPY**

*The research reported in this document has been sponsored
by the National Aeronautics and Space Administration under
grant NGL 39-009-015.*

IONOSPHERE RESEARCH LABORATORY

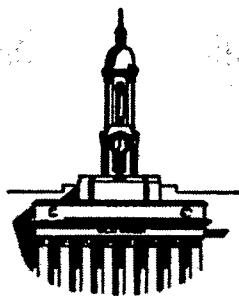

University Park, Pennsylvania

PSU-IRL-SCI 392(E)

Scientific Report 392(E)

"A Unique Modulation System for Two Channel
Data Transmission"

by

Bruce Thorne Melrose

May 15, 1972

"The research reported in this document has been sponsored by
the National Aeronautics and Space Administration under grant
NGL 39-009-015."

Submitted:

Leslie C. Hale

Leslie C. Hale, Professor of Electrical Engineering
Project Supervisor

Approved:

J. S. Nisbet

J. S. Nisbet, Director
Ionosphere Research Laboratory

Ionosphere Research Laboratory

The Pennsylvania State University

University Park, Pennsylvania 16802

ACKNOWLEDGEMENTS

The author wishes to express his appreciation for the support and guidance supplied by Dr. L. C. Hale.

The author also wishes to thank Mr. Richard W. Bryant and Mr. Charles Croskey for their time spent discussing implementation problems.

This work was supported by the National Aeronautics and Space Administration under grant NGL 39-009-015 for which we are grateful.

TABLE OF CONTENTS

	Page
ACKNOWLEDGEMENTS	ii
LIST OF FIGURES	v
1. INTRODUCTION	1
2. SYSTEM DESCRIPTION	3
3. THEORY	8
3.1 Threshold Sensitivity and Noise Considerations	8
3.2 Bandwidth	9
3.3 Signal to Noise Ratio	10
3.4 Low Pass Filter, Demodulator, and Channel Separation	12
3.5 Summary	13
4. MODULATION DESIGN	15
4.1 Modulator Description	15
4.2 Main Channel Module Operation	15
4.3 Main Channel Design	22
4.4 Second Channel Module Operation	23
4.5 Second Channel Module Design	25
4.6 Dual Channel Modulator Test Results	26
4.7 Summary	29
5. DEMODULATOR DESIGN	31
5.1 Demodulator Description	31
5.2 The Input Stage	34
5.3 The Channel Separator Stage	34
5.4 The Low Pass Filters	36
5.5 The Power Supply and Voltage Regulators	42

	Page
5.6 Summary	44
BIBLIOGRAPHY	45
APPENDIX: DERIVATION OF THE SIGNAL TO NOISE RATIO	46

LIST OF FIGURES

Figure		Page
1.	COMPOSITE SIGNAL AMPLITUDE VS. TIME (CASE 1, CASE 2, CASE 3)	4
2.	BLOCK DIAGRAM OF THE TWO CHANNEL SYSTEM AND TELEMETRY LINK	6
3.	CIRCUIT WAVEFORMS AS A FUNCTION OF NORMALIZED TIME	17
4.	SCHEMATIC DIAGRAM OF VOLTAGE CON- TROLLED SAWTOOTH-PULSE GENERATOR	18
5.	SAWTOOTH-PULSE GENERATOR MODEL FOR THE RAMP PORTION OF A CYCLE	19
6.	SAWTOOTH-PULSE GENERATOR PULSE PERIOD MODEL	21
7.	DUTY CYCLE MODULATOR SCHEMATIC DIAGRAM	24
8.	MAIN CHANNEL INPUT SIGNAL VOLTAGE VS. OUTPUT PULSE REPETITION RATE	27
9.	SECOND CHANNEL INPUT SIGNAL VOLTAGE VS. OUTPUT DUTY CYCLE	28
10.	DEMODULATOR BLOCK DIAGRAM	33
11.	CIRCUIT SCHEMATIC FOR DEMODULATOR INPUT STAGE	35
12.	CIRCUIT SCHEMATIC FOR DEMODULATOR CHANNEL SEPARATOR STAGE	37
13.	CIRCUIT SCHEMATIC FOR LOW PASS FILTER	38
14.	BODE PLOT OF AMPLITUDE VS. FREQUENCY FOR THE LOW PASS FILTERS	41
15.	CIRCUIT SCHEMATIC OF THE POWER SUPPLY AND REGULATORS	43

CHAPTER 1

INTRODUCTION

This work describes a simple low cost telemetry system. While not restricted to this, the application concerned is the telemetry of information from meteorological rocket payloads including parachute borne systems. Such systems generally use S- or L-band microwave links with low cost oscillator type transmitters having inherently poor frequency stability. The microwave receiver commonly used is basically set up as a single channel system. The transmitted information is in the form of a pulse train whose repetition frequency varies from 20 - 200 Hz. The information bandwidth is limited to 10 Hz by a fixed frequency sampling filter.

The simple extension of this system to transmit two channels of data simultaneously is considered herein. The two channel system is different from the multi-channel case in that more possibilities exist for the design of such a system. The usual multiplexing techniques are unduly complicated and inefficient when considered for the two channel case. The two channel system described herein circumvents the problems encountered with standard time and frequency multiplexing techniques. It also maintains compatibility with existing equipment, and does so with surprisingly simple circuitry.

The system transmits the two channels of information as a sampled pulse train. One channel is represented by the pulse

repetition rate while the other channel is represented by the instantaneous duty cycle of the pulse train. The reasons for this choice are developed later.

CHAPTER 2

SYSTEM DESCRIPTION

The purpose of the two channel telemetry system is to reproduce at the receiver two particular voltage waveforms which are present in a rocket payload. To maintain compatibility with previously used data reduction techniques and equipment, a single composite signal which contains both channels of information must be present at the receiver, and must be capable of reproduction by way of an audio tape recorder. The two channel system described below provides such a signal without using standard time or frequency multiplexing techniques. The signal is in the form of a continuous pulse train with the original channel of information contained in the repetition rate of the pulses, and the second channel of information contained in the duty cycle of the pulses. The system contains both a modulator and a demodulator which are compatible with the existing single channel telemetry link.

The modulator provides the composite signal which is characterized by the three cases shown in Figure 1. The first case shows a sample of the pulse train for high repetition rate and high duty cycle. Comparison of case 1 with case 2 demonstrates that for a constant duty cycle the pulse width increases by a factor of two as the repetition rate decreases by a factor of one-half. Case 3 may be compared with case 1 to show that the pulse width remains constant when both the repetition rate and the duty cycle change by the same factor. The signal that these cases represent is present at both the payload transmitter input and at the ground based receiver output.

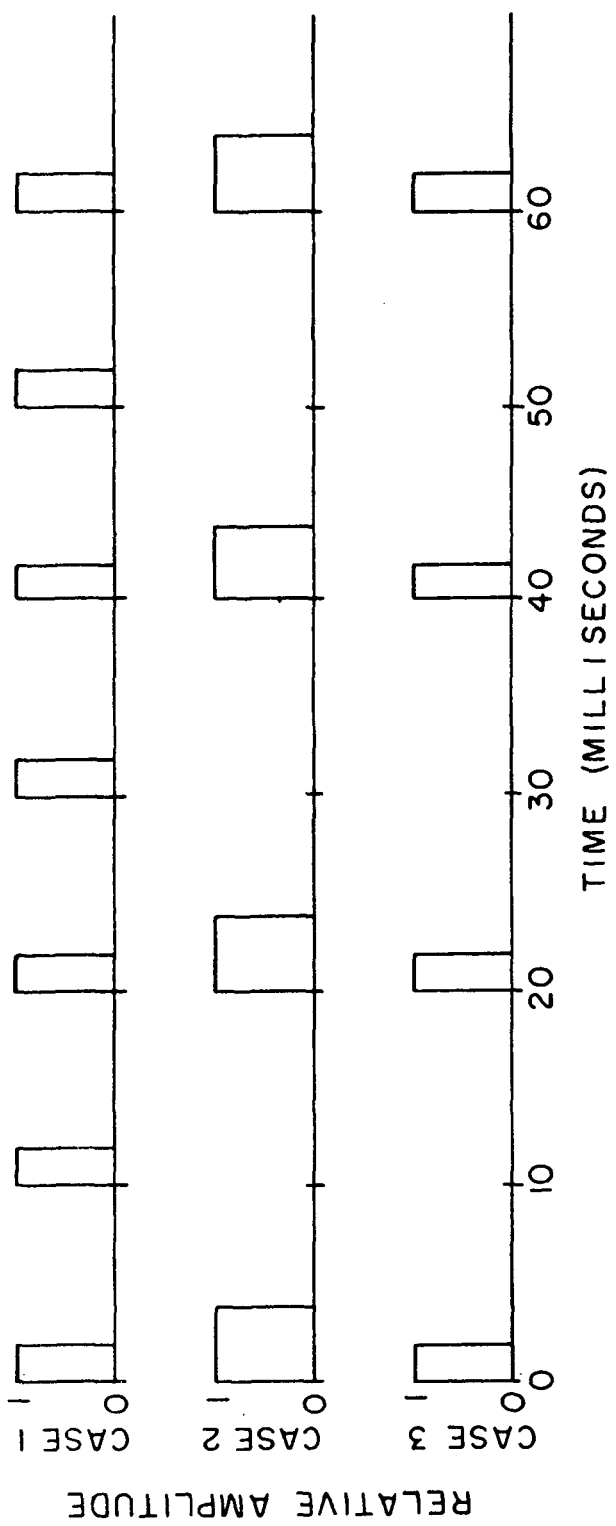

FIGURE 1
 COMPOSITE SIGNAL AMPLITUDE vs TIME
 (CASE 1, CASE 2, CASE 3)

A block diagram of the two channel system and telemetry link is shown in Figure 2. For the rocket-borne modulator, slowly changing input signal voltages represent the information to be transmitted to the ground base. The main channel input signal is applied to a voltage controlled sawtooth generator whose output repetition rate is linearly related to the input signal voltage. This sawtooth and the second channel input signal voltage are applied to the duty cycle modulator whose output is the composite pulse train which contains both channels of information. The composite pulse train is used to key a quarter wavelength cavity transmitter which oscillates at 1,680 MHz. The receiver is used to obtain the composite pulse train at the ground base. A standard I. R. I. G. timing code is generated at the ground base and recorded along with the composite pulse train to provide a time reference for data reduction at a later date. Simultaneously the composite signal is monitored by the demodulator unit. The demodulator consists of a low pass filter for each channel of information, and a monostable multivibrator which separates the main channel pulse train from the composite pulse train. The main channel pulse train is characterized by fixed pulse width and variable pulse repetition rate. The low pass filters reduce the two pulse trains to their corresponding waveforms which are present in the payload. A discussion of the low pass filter action is contained in Chapter 3.

The demodulator contains its own regulated power supplies and an adjustable interface which provides adaptability to various input and output constraints. It is packaged in a 3" x 4" x 5"

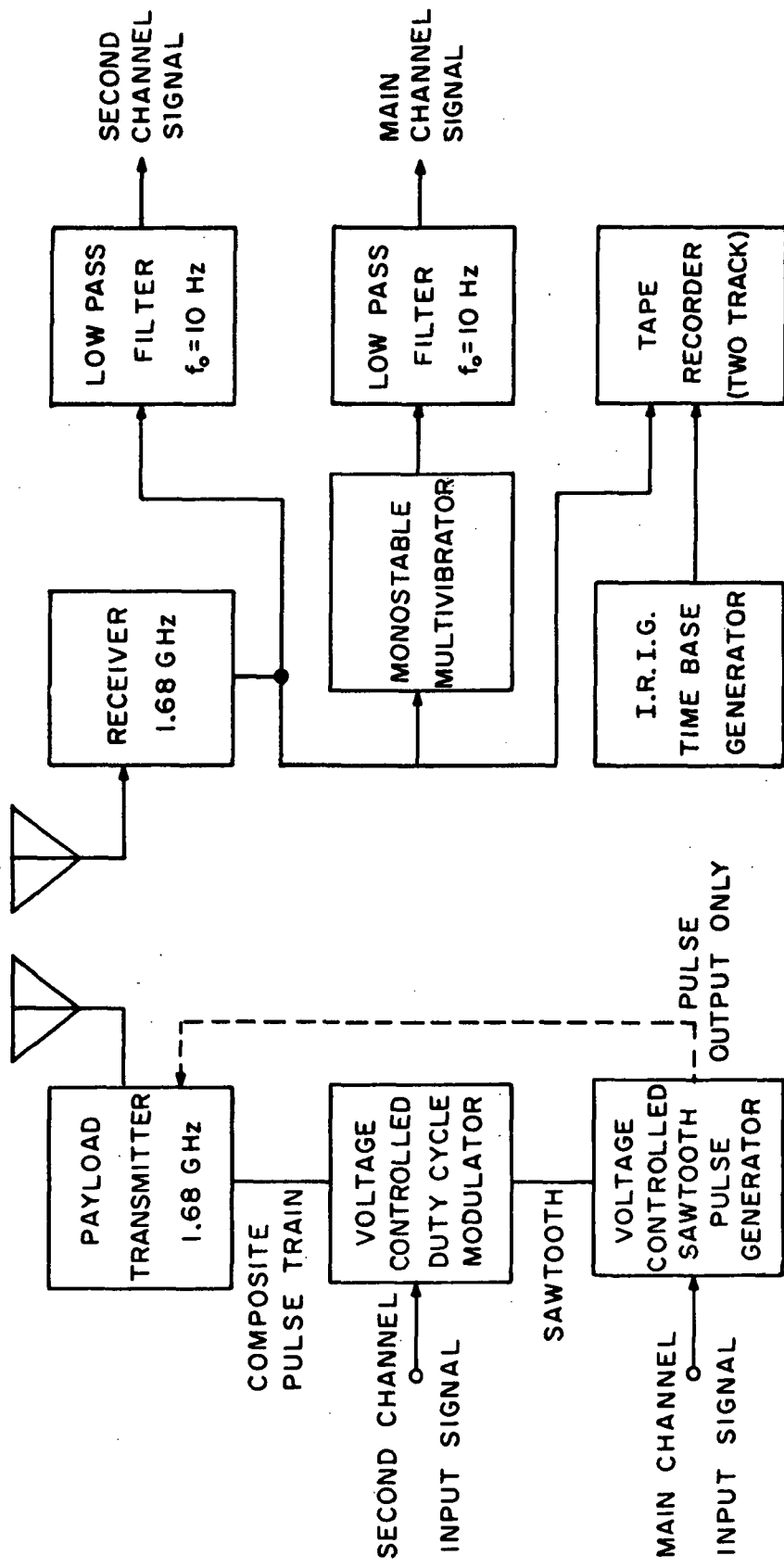

FIGURE 2
 BLOCK DIAGRAM OF THE TWO CHANNEL SYSTEM
 AND TELEMETRY LINK

"minibox" to minimize size as portability is also desired. A more detailed description of both the modulator and the demodulator is given in Chapters 4 and 5.

CHAPTER 3

THEORY

3.1 Threshold Sensitivity and Noise Considerations

In the design of a telemetry link, a primary consideration is the carrier signal strength required to maintain a minimum signal to noise ratio. Since the transmitter used in this system exhibits constant peak power limitations, and considering propagation conditions which are likely to occur, the received carrier signal strength is expected to be small. Using a crest factor of four and assuming the pulse slicing occurs at the one-half height point, the video improvement threshold is given in equation (1). This shows that the

$$h = 8N = 8K(F_c)^{1/2} \quad (1)$$

where

- h = the pulse amplitude
- N = the RMS noise voltage
- K = a constant
- F_c = the system bandwidth

price of noise improvement is bandwidth since the bandwidth can be minimized for a signal with a fifty percent duty cycle, such a signal is advantageous to use in terms of the signal to noise ratio.

If a large duty cycle is coupled with digital filtering on the receiving end the result is a very adaptable system. For very noisy signals, the bandwidth can be reduced to obtain the best signal

to noise ratio, or the bandwidth can be increased for low noise signals to obtain a higher data rate.

The above discussion applies to the conditions where white noise is predominant. However, a large duty cycle signal is also advantageous in an environment of impulse noise, since narrow bandwidth systems discriminate against impulses. As a result, this system is suitable for use in very noisy environments of either type.

Due to the threshold sensitivity and poor stability of the transmitter, keyed amplitude modulation was chosen. F.M. was discarded as it only gives a high signal to noise ratio when it is already high to begin with. Other techniques such as positive and negative amplitude modulation require stability and symmetry which result in too critical system adjustments and unequal channel capacity.

3.2 Bandwidth

The bandwidth necessary to transmit a pulse train is a function of the rise and fall times of the pulses. The pulse train bandwidth is approximately one-half the inverse of the rise time or fall time, whichever is smaller. The radio frequency bandwidth is twice the pulse train bandwidth. Since the dual channel modulator requires rise and fall times on the order of five microseconds or less, the corresponding pulse train bandwidth is 100 KHz, and the corresponding radio frequency bandwidth is 200 KHz.

3.3 Signal to Noise Ratio

The results of this section assume that the communication link exerts the influence of an ideal low pass filter on the received composite pulse train due to the system bandwidth. Since the composite train is assumed to be ideal, the bandwidth restriction causes the received pulses to exhibit finite rise and fall times. For the purpose of examining the signal to noise ratio, each channel is assumed to be fully modulated by a sinusoidal tone, and each received pulse is assumed to be sliced at its half height point. The transmitter is assumed to be off the presence of a pulse, and on in the absence of a pulse.

Since the main channel information is dependent only on the position of the leading edge of each pulse, and assuming an A. M. detector is employed, the expression for the signal to noise ratio of the main channel is given in equation (2).

$$S/N (1) = \frac{hF_c}{\sqrt{2} N} \left[\frac{1}{F_1} - \frac{1}{F_2} \right] \quad (2)$$

where

- h = the detected pulse amplitude
- F_c = the system video bandwidth
- F_1 = the maximum P. R. F.
- F_2 = the minimum P. R. F.
- N = the R. M. S. noise voltage

The second channel information is dependent on the position of both the leading, and trailing edges of each pulse, and the signal to noise ratio corresponding to this channel is given in equation (3).

$$S/N (2) = \frac{hF_c}{\sqrt{2} N} \left(\frac{1}{F_2} - \frac{1}{F_2} \right) \left(\frac{1 + D^2}{2} \right)^{1/2} \quad (3)$$

where

D = the maximum duty cycle of the pulse train

h, F_c , F_1 , F_2 , and N are defined above

The equations derived for the signal to noise ratios consider only R.M.S. timing errors, and assume that the highest frequency component of the original modulating signal corresponds to one-half of the sampling rate. They also assume that the noise amplitude is always less than one-half of the pulse height. From these equations it is clear that reducing the minimum pulse repetition frequency effectively increases the signal to noise ratio for both channels. Due to the Sampling Theorem such a change also decreases the highest frequency component of the original modulating signal that may be received. In light of this, and knowing the frequency spectrum of the original modulating signal, the minimum P.R.F. is evaluated in terms of a trade off between signal to noise ratio and distortion due to spectrum truncation.

For the second channel the signal to noise ratio is always less than or equal to that of the main channel, and can be maximized by increasing the maximum duty cycle of the pulse train. For large duty cycle variations circuit implementation problem may be encountered. Also for duty cycle variations greater than fifty percent the detector in the radio receiver may require modification to ensure that the pulse train is not inverted when the duty cycle exceeds fifty percent.

3.4 Low Pass Filter, Demodulator, and Channel Separation

For each of the two channels the final stage of demodulation is performed by a fixed frequency low pass filter. Each channel of information is represented by its pulse train as it enters the filter, and at the output by the Fourier Series D. C. component of the respective input pulse train. The D. C. component may also be considered as the instantaneous average amplitude per unit time of the pulse train waveform. For pulse width (T_1), period (T_2) and peak pulse amplitude h , the D. C. component (V_o) is given in equation (4).

$$V_o = h(T_1/T_2) \quad (4)$$

For fixed pulse width (T_1), as in the main channel pulse train, equation (4) shows that the output voltage is inversely related to the pulse period. Thus modulating the pulse period while maintaining a fixed pulse width produces an output voltage that changes in accordance with the period modulation.

The second channel pulse train is characterized by modulation of the duty cycle ratio (T_1/T_2) independent of the pulse period. Equation (4) also shows that modulating the duty cycle ratio produces an output voltage that changes in accordance with the modulation supplied.

Since the main channel of information is contained only in the spacing between the leading edges of the pulses, and the second channel duty cycle modulation is independent of the pulse period, both channels of information may be transmitted simultaneously as one waveform.

This composite transmitted waveform exhibits modulation of both the pulse period and the duty cycle. The main channel pulse train may be regenerated at the receiver by a monostable multivibrator.

3.5 Summary

Various theoretical aspects of the two channel communication system are described above. Evaluation of these considerations shows that a two channel communication system with a high signal to noise ratio can be achieved at the expense of radio frequency bandwidth. In addition both channels of information may be transmitted on the same pulse train while allowing a relatively simple demodulation scheme.

Future work may include evaluation of channel crosstalk, harmonic distortion, and intermodulation distortion for the modulation scheme used. Also the use of frequency shift keying to obtain a constant power transmitted signal, receiver error detection capabilities, and improved noise immunity may be investigated.

Past data reduction has shown that noise in the form of bursts greater than one-half of the pulse amplitude may cause considerable signal degradation. The effect of such noise is more predominant in the main channel due to the monostable multivibrator employed in the demodulator. If such noise is present, the effect on the main channel information may be minimized by generating pulses of greater duration in the monostable multivibrator. The second channel is less effected by such noise due to its potentially large duty cycle. Greater noise burst immunity may be obtained by changing

the duty cycle range to a minimum of twenty-five percent and a maximum of seventy-five percent. Future improvements could also include the use of "flywheel" circuits to eliminate spurious noise bursts, and to generate pulses during momentary signal dropouts.

CHAPTER 4

MODULATOR DESIGN

4.1 Modulator Description

The purpose of the two channel modulator is to provide a continuous train of pulses suitable for transmission via radio telemetry link from a rocket borne payload to the ground based receiver. A linear input-output characteristic is exhibited by both channels, and both channels function independently of each other. The input signal voltage of both channels must be positive with respect to ground, but less than the supply voltage. The output pulses are of negative sense, and are approximately twice the positive supply voltage in amplitude. The unit is designed to operate from positive and negative 17 volt regulated supplies, and a nominal 22 volts unregulated. Considerations of reliability, stability, cost, power drain and size are observed in the modulator design.

For the purpose of discussion the unit is sub-divided into two function modules which represent the two data channels. The main channel module is termed a voltage controlled sawtooth-pulse generator, and the second channel module is termed a voltage controlled duty cycle modulator capable of operation independent of pulse frequency.

4.2 Main Channel Module Operation

The voltage controlled sawtooth pulse generator serves a dual function as it provides both a sawtooth output for use with the duty cycle modulator, and a pulse output which is compatible with

the payload transmitter. The second channel electronics may be eliminated if only a single channel of data transmission is required. The peak to peak amplitude of both outputs is maintained constant, and their leading edges are synchronized as shown in Figure 3. A single cycle of the sawtooth generator is divided into three parts which describe the module operation: ramp generation, transition, and pulse period.

Consider the ramp generation and refer to Figure 4 for the circuit schematic. A circuit model used to describe the ramp generation is given in Figure 5. It is assumed that transistor Q1 has a reasonably high beta, that a positive input voltage is supplied, and that the comparator appears to have infinite input impedance. In the model the controlled current source I represents transistor Q1 along with its biasing components. The operational amplifier IC 1 along with its biasing components is modelled as an ideal comparator. The reference voltage V2 is established by diode D1 and resistor R2.

This portion of a cycle results from charging a capacitor with a constant current source to obtain a voltage ramp. Equation 5 is derived from the voltage current relationship of a charged capacitor. Thus during the ramp portion of a cycle the voltage at the sawtooth output terminal exhibits a linear relation to time (t), and the slope of the output ramp is equal to the ratio of the charging current (I1) to the value of capacitor C1. The output voltage continues to increase at a constant rate until it becomes equal to the reference voltage V2. When this occurs the ramp portion of a cycle is terminated, and the transition is initiated.

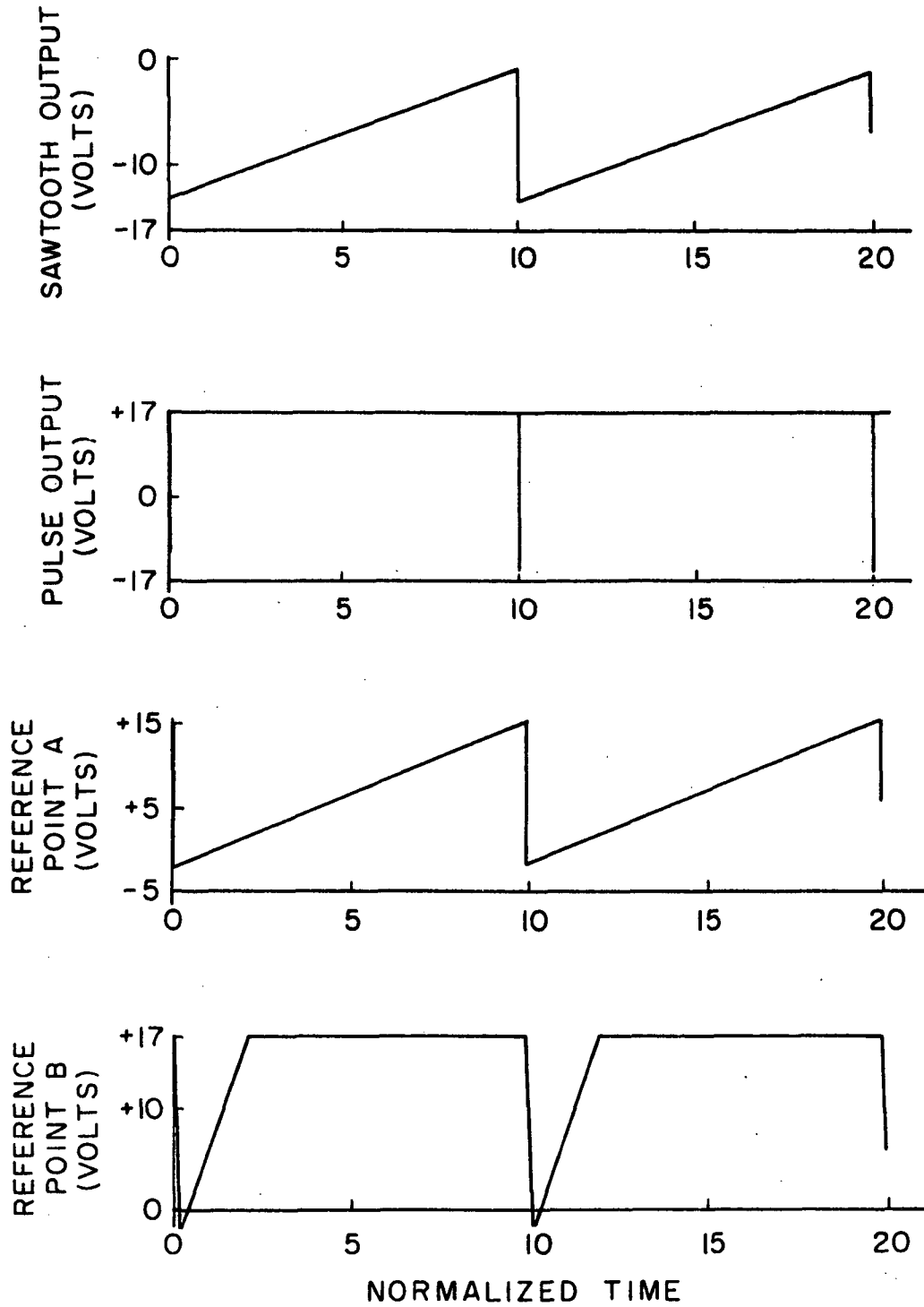

FIGURE 3
CIRCUIT WAVEFORMS AS A FUNCTION
OF NORMALIZED TIME

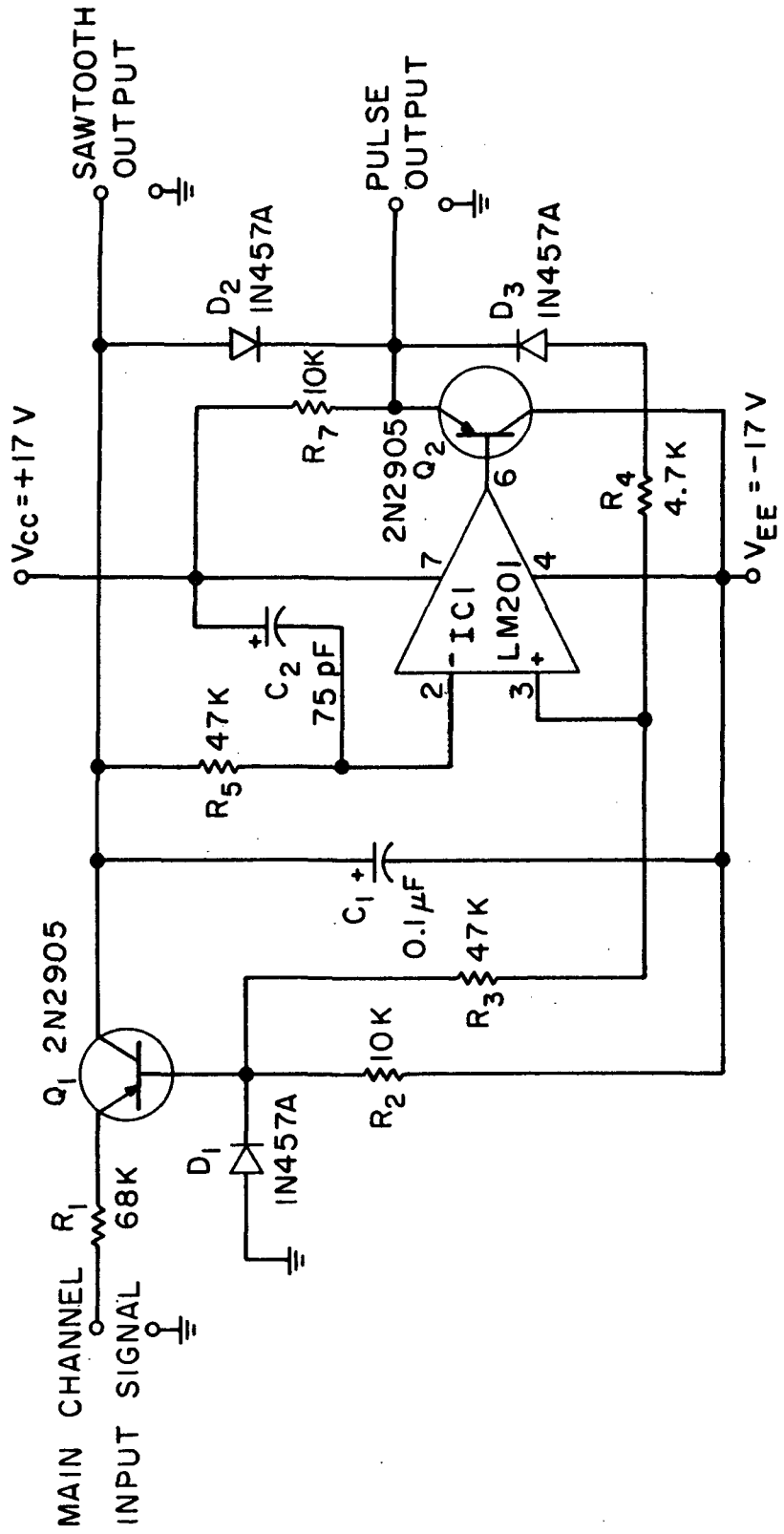

FIGURE 4
SCHEMATIC DIAGRAM OF VOLTAGE CONTROLLED
SAWTOOTH - PULSE GENERATOR

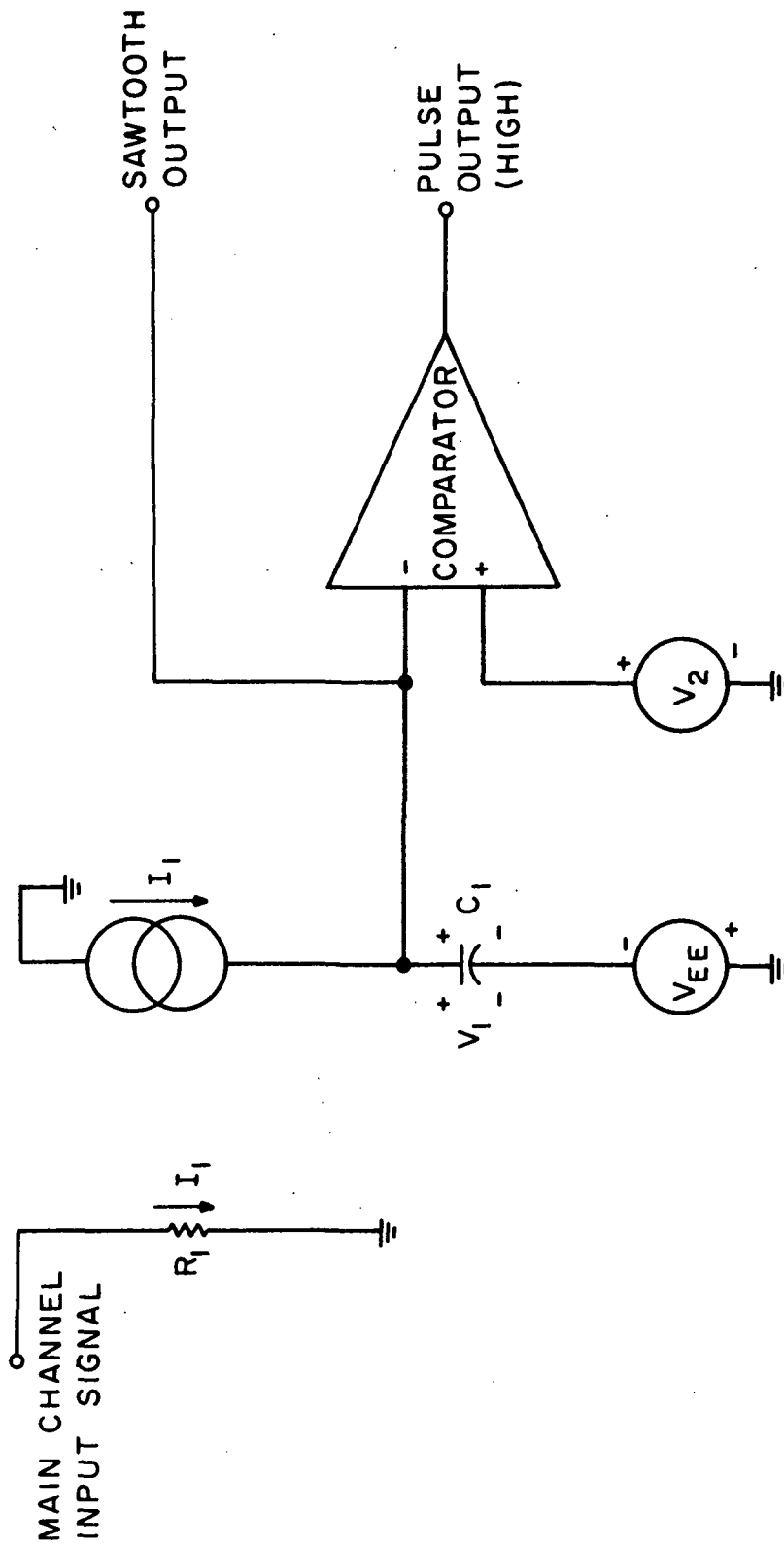

FIGURE 5
 SAWTOOTH-PULSE GENERATOR
 MODEL FOR THE RAMP PORTION OF A CYCLE

$$V_{\text{sawtooth}} = V_1 - V_{EE} + t(V_{IN}/R_1 \cdot C_1) \quad (5)$$

During ramp generation the operational amplifier is saturated, and its output voltage is approximately the positive supply voltage. A few millivolts difference between the comparator's input terminals is sufficient to drive the output from positive saturation to negative saturation. When the ramp output voltage becomes slightly greater than the reference voltage V_2 , the output voltage drops to the value which applies a forward bias to diodes D_2 and D_3 . At this point the comparator load changes from resistive to capacitive. Since the comparator is current limited, transistor Q_2 provides the high current necessary to discharge capacitor C_1 while maintaining a short transition time. During the transition the inverting input is held more positive than the non-inverting input to ensure that negative saturation is reached.

The pulse period is considered to be the length of time that the comparator output voltage is at the negative saturation state. Figure 6 shows the model which represents the circuitry during the pulse period. The voltage source V_2 represents the reference voltage established by diode D_1 , and the voltage source V_3 represents the negative saturation voltage of the comparator including the voltage drops due to transistor Q_2 and diodes D_2 and D_3 . The comparator input bias and offset currents are assumed to be negligible. During this portion of a cycle, the non-inverting comparator input voltage is established by the potential divider resistors R_3 and R_4 . At the beginning of the transition the inverting

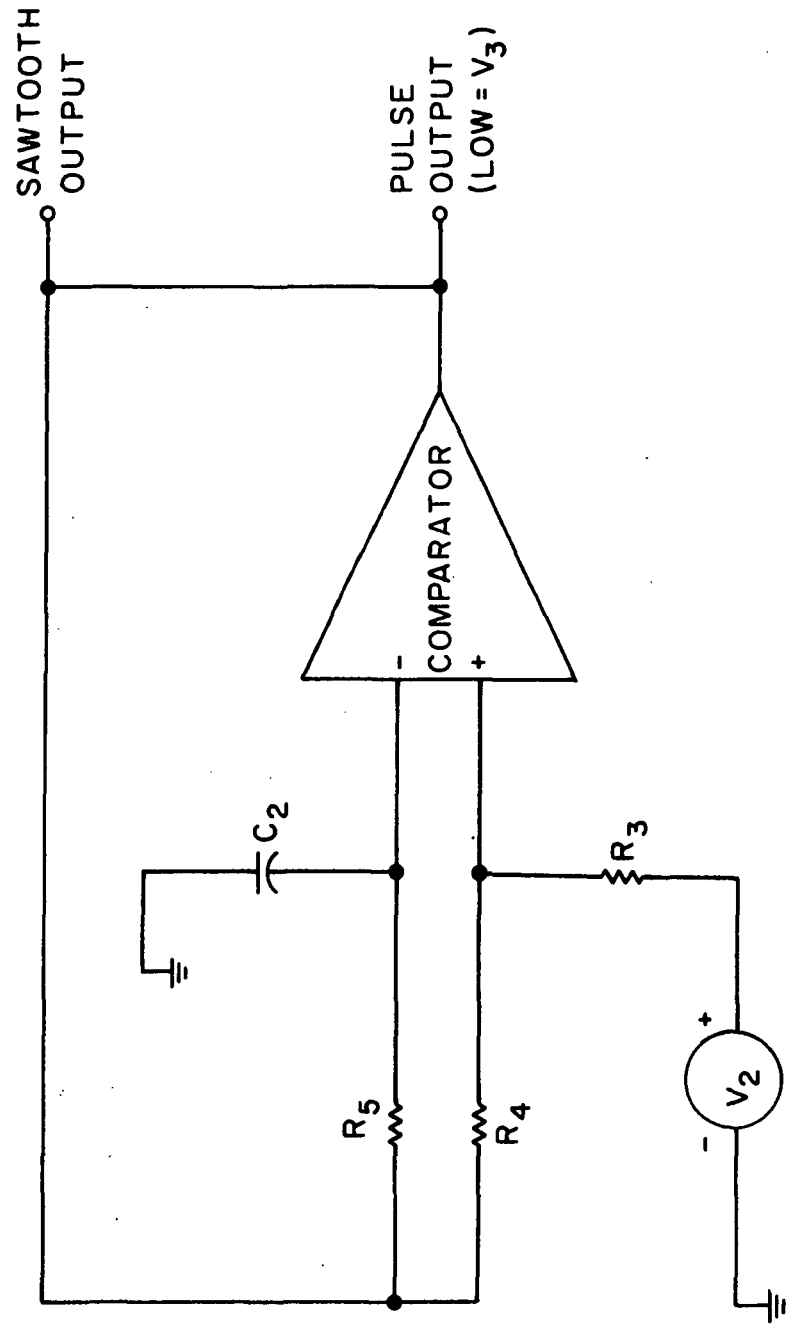

FIGURE 6
SAWTOOTH - PULSE GENERATOR
PULSE PERIOD MODEL

input voltage is approximately V_2 . Equation (6) shows that the pulse width T is independent of the saturation voltage V_3 , and is therefore also independent of the transition time.

$$T = 2\pi \cdot R_5 \cdot C_2 \cdot \text{Ln} \left((R_3 + R_4) / R_4 \right) \quad (6)$$

Natural Log = Ln

At time T after the transition starts, the pulse ends and the next cycle starts in ramp operation.

4.3 Main Channel Design

Certain restrictions are imposed on the main channel module design by payload compatibility requirements. The payload power supplies are positive and negative seventeen volts regulated, and positive and negative unregulated supplies nominally 22 volts. The range of pulse repetition frequency is restricted to 200 pps maximum, and 10 pps minimum. The duty cycle modulator requires sharp leading edge transitions, and small pulse widths (less than 10 microseconds) to minimize error terms.

Equation 5 is solved for the time constant R_1C_1 at the maximum input voltage, and maximum pulse repetition rate. The value of capacitor C_1 is determined by a trade off among linear ramp characteristics, small discharge time, and input impedance at the input signal terminal. A large capacitor requires large discharge currents during transition, and a small capacitor allows comparator bias and offset currents to become significant. The value of resistor R_2 is set small to maintain a stable reference voltage V_2 .

The voltage divider resistors R3 and R4 help to establish the pulse widths, and must be small enough that comparator input currents may be ignored. Their ratio is set at about ten to one to minimize errors due to capacitor C2's charging currents. Capacitor C2 must be much smaller than capacitor C1, but large enough such that comparator input currents do not effect its operation. Resistor R5 is evaluated from Equation 6.

The most critical component is capacitor C1 since value changes due to temperature and component tolerances directly effect the pulse repetition frequency. The positioning of this component is also important. Due to its large discharge currents during transition, positioning in close proximity to the non-inverting comparator input terminal causes a noticeable jitter in both pulse repetition frequency and pulse width.

4.4 Second Channel Module Operation

The voltage controlled duty cycle modulator is an optional unit that may be added to the sawtooth pulse generator to provide a second channel of data transmission. During operation this module must be connected to the sawtooth output of the main channel module, and supplied with a positive input signal voltage. A schematic diagram of the circuit is given in Figure 7.

Basically three processes are performed to provide a composite output pulse train which contains information from both channels. Capacitor C3 and diode D4 provide level shifting of the sawtooth waveform from the main channel module, and establish a reference level for amplication. The second process is performed

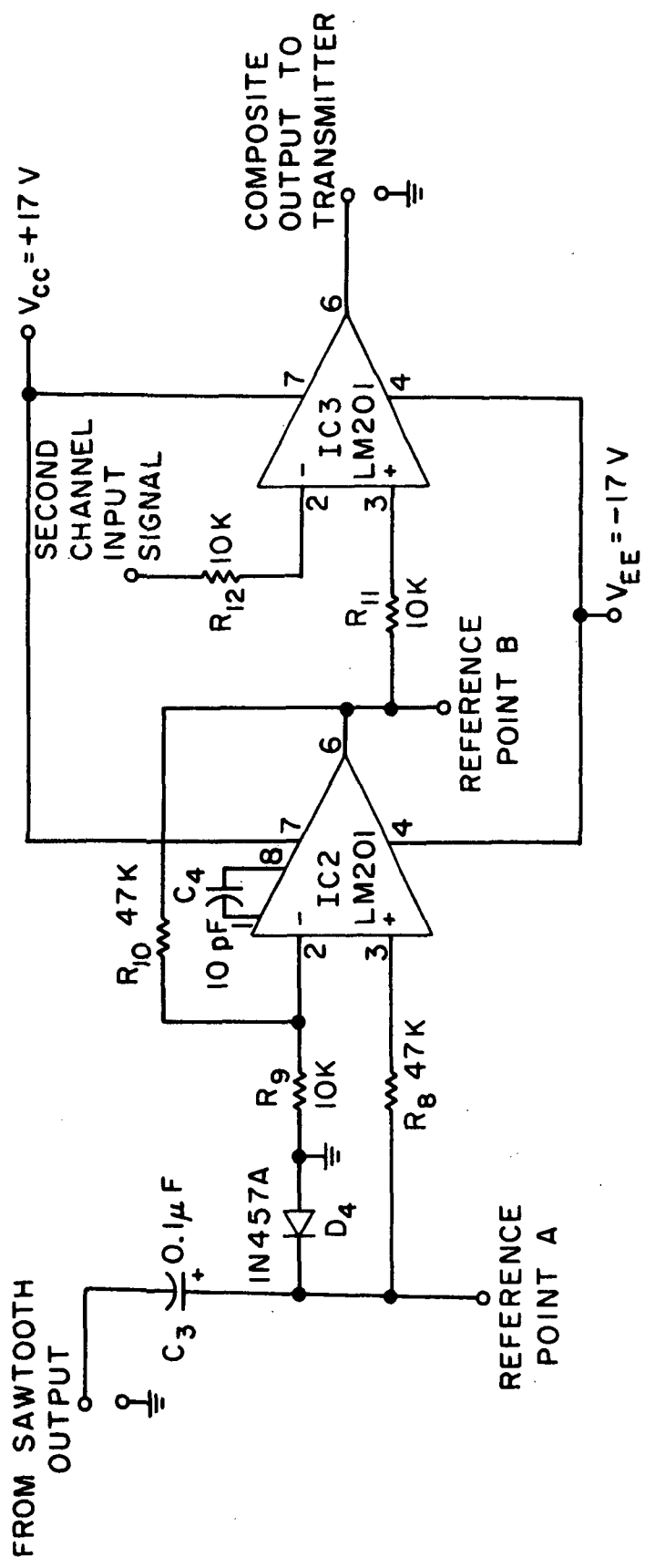

FIGURE 7
DUTY CYCLE MODULATOR SCHEMATIC DIAGRAM

by operational amplifier IC 2. The sawtooth waveform is amplified and clipped to provide the waveform shown in Figure 3 as voltage reference point B. This waveform is supplied to the non-inverting input of a final comparator IC 3. The inverting input to this comparator is supplied with the second channel input signal voltage. The comparator output provides a negative pulse during the time when the amplified clipped sawtooth is less than the input signal voltage and is saturated at the positive supply voltage otherwise. Thus, the composite pulse train at the comparator output appears as a train of pulses synchronized to the repetition frequency of the main channel modulator, and exhibiting a duty cycle which is linearly related to the second channel input signal voltage.

4.5 Second Channel Module Design

Component tolerances and positioning are not critical in this circuit. Capacitor C3 should be equal to or greater than the value of capacitor C1 which is used in the sawtooth generator. Capacitor C4 provides the minimum external compensation necessary to maintain the stability of operational amplifier IC2. The resistor values provide the desired gain and ensure that the clamped amplified waveform starts at a slightly negative voltage even for worst case input offset currents.

Several operational amplifiers are suitable for use in the modulator circuit, but any replacement should meet the following requirements. Comparators IC1 and IC3 should exhibit a slow rate on the order of three volts per microsecond uncompensated. Latch up protection, and short circuit current limiting are necessary for all

three operational amplifiers. Maximum input bias currents should be less than 250 microamperes. Attention should be paid to the change in bias and offset currents and voltages as a function of temperature.

4.6 Dual Channel Modulator Test Results

Test results of the completed circuit taken at room temperature from the output terminal of comparator IC3 are shown in Figures 8 and 9. The test equipment used is expected to have a maximum error of plus or minus two percent. Figure 8 "Main Channel Input Signal Voltage Versus Output Pulse Repetition Rate", demonstrates the linearity of the input-output relation of the sawtooth pulse generator. All the data points shown on this figure were taken at a duty cycle of 12.8%, but no deviation from these values were observed over the entire range of duty cycle from 0.5% to 26%.

Figure 9 "Second Channel Input Signal Voltage Versus Output Duty Cycle", contains two curves and demonstrates both the linearity of the input-output relation, and the degree of independence from the pulse repetition frequency. Curve A on this graph contains coincident points for all pulse repetition frequencies greater than 7 pps, which corresponds to a main channel input signal voltage of greater than one-half volt. Over this range, the input-output relation is shown to be linear with a slight deviation from a straight line at small duty cycle, and is independent of pulse repetition frequency. The deviation from a straight line at small duty cycle is a result of finite pulse width exhibited on the sawtooth output of the main channel modulator. Curve B shown on the same graph represents the input

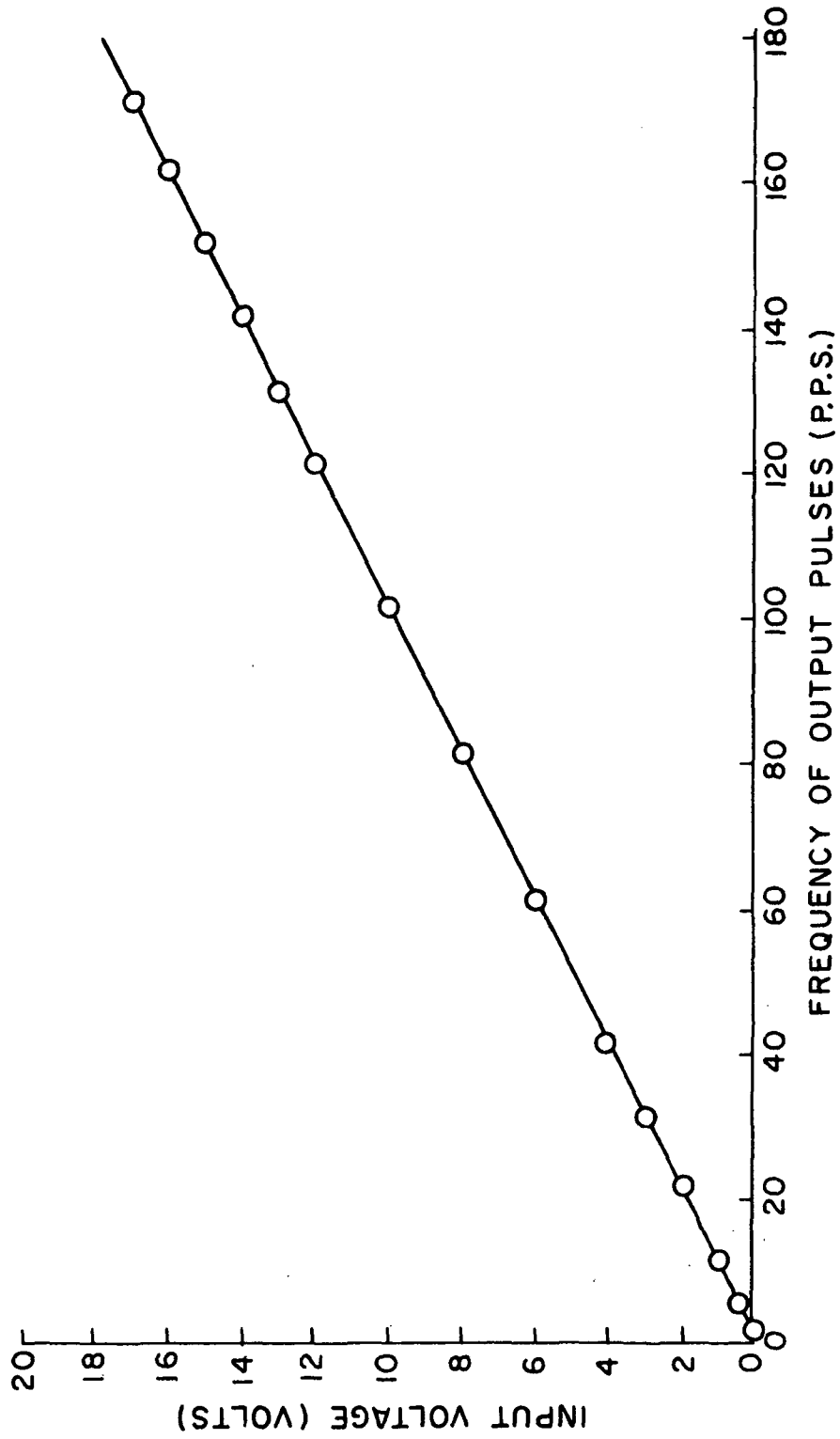

FIGURE 8
MAIN CHANNEL INPUT SIGNAL VOLTAGE vs
OUTPUT PULSE REPETITION RATE

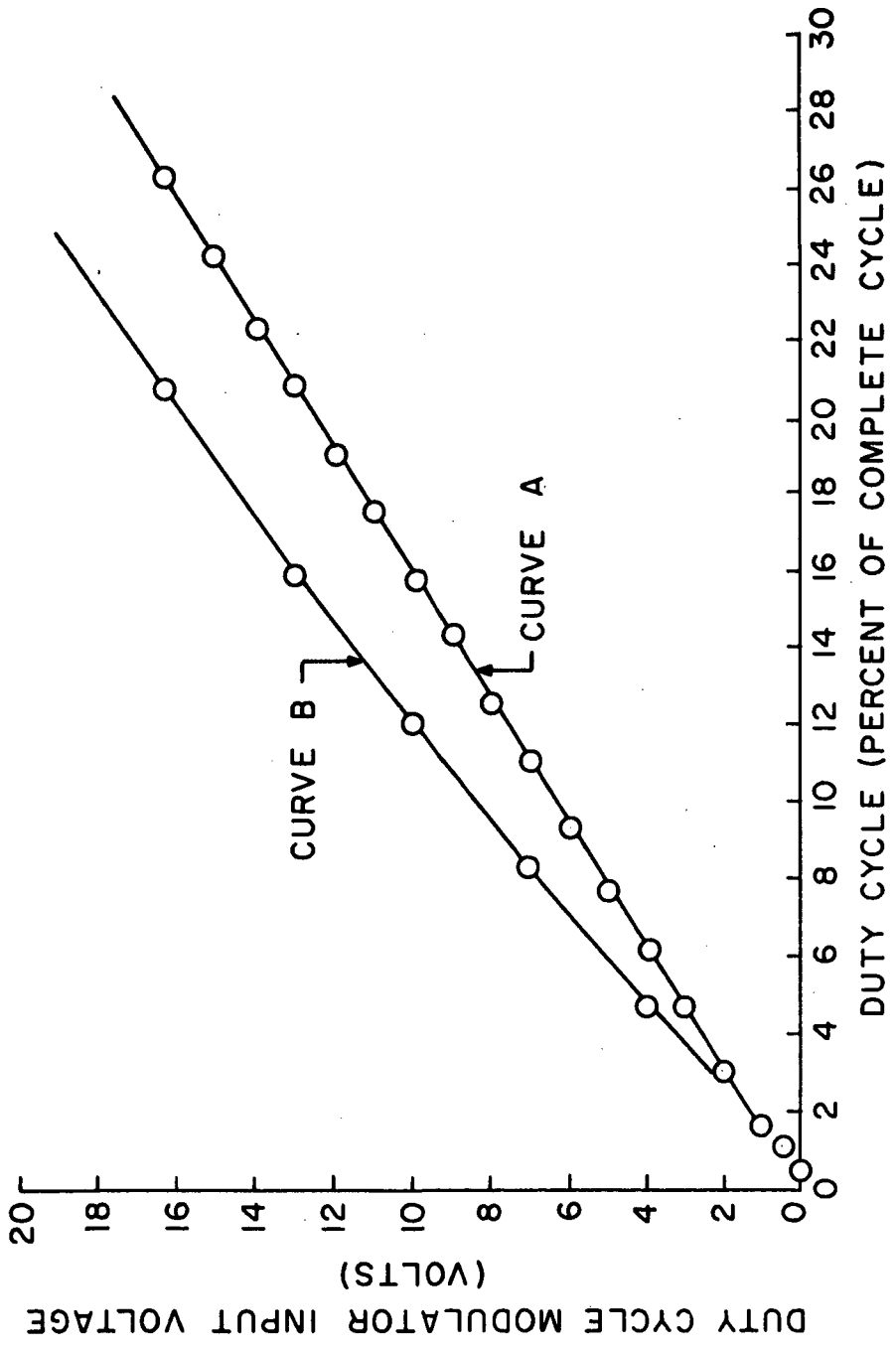

FIGURE 9
 SECOND CHANNEL INPUT SIGNAL VOLTAGE vs OUTPUT DUTY CYCLE

output relation measured at a repetition frequency of 2 pps which corresponds to a main channel input signal voltage of zero volts. This curve demonstrates the error due to very low pulse repetition frequencies.

Three solutions are presented to minimize this error or to prevent its appearance. First limiting the main channel input signal voltage to values greater than 0.5 volts by using a diode reference will prevent this error from appearing. Second, reducing the bias and offset currents associated with IC1 and IC2 will reduce the repetition rate at which the error appears. Third, increasing the value of capacitors C1 and C3 will reduce the repetition rate at which the error appears, but may cause undesirable effects during the transition and pulse portions of a cycle.

Another problem that should be considered which is not apparent from the graphs is that the second channel input signal voltage should not exceed the positive saturation voltage of IC2. The second channel input signal should be limited to approximately one volt less than the positive supply voltage to ensure proper operation.

4.7 Summary

A simple, reliable, inexpensive, two channel modulator suitable for rocket payload instrumentation has been developed, tested, and found to perform satisfactorily. Capacitor C1 is found to be the only critical component in terms of tolerance, and layout, and should exhibit a small temperature coefficient. The complete unit should perform satisfactorily over the temperature range of

0° - 70° centigrade. Future work may include temperature studies, reducing effects due to power supply fluctuations, and automatic calibration techniques.

CHAPTER 5

DEMODULATOR DESIGN

5.1 Demodulator Description

The demodulator reproduces the main channel signal and the second channel signal from the composite pulse train referred to in Chapters 3 and 4. The composite pulse train is usually obtained either at the G. M. D. receiver output, or from a tape recording of the receiver output. The main channel signal and the second channel signal are the respective modulator inputs present in the payload at the time of transmission.

The demodulator unit contains five front panel controls which provide a flexible interface to the input and output terminals. Switch S1 enables the unit to accept either positive sense input pulses in the normal position, or negative sense input pulses in the invert position. Switch S2 controls the A. C. power to both the demodulator unit and the power indicator light. Control R4 adjusts the input threshold voltage, and is used to reduce the effect of noise on the input composite pulse train. The two remaining front panel controls (R22A and R22B) provide a D. C. offset adjustment for each output signal.

Four terminals located on the rear panel are supplied for access to the unit, they are: composite pulse train input, input threshold monitor, main channel output signal, and second channel output signal. The input threshold monitor terminal was included to aid in determining the best threshold setting. An A. C. line cord and a fuse holder are also located on the rear panel.

The demodulator operates first to define and separate the two channels of the input pulse train, then to extract the appropriate signal waveform from its respective pulse train. Figure 10 shows the function blocks employed in the demodulator.

The input stage contains a comparator and an adjustable interface between the comparator and the input source. The interface includes the pulse sense switch S1, the threshold monitor J2, and the threshold adjustment control R4. This stage reduces the effects of noise on the composite pulse train and eliminates amplitude variations.

Following the input stage is the channel separator which contains a monostable multivibrator, and a Schmitt Trigger. The channel separator has two outputs each in the form of a pulse train. One represents the main channel and is characterized by fixed pulse width, and variable pulse repetition rate. The other pulse train represents the second channel and is characterized by variable duty cycle independent of pulse repetition rate.

Each of the channel separator outputs are processed by a low pass filter to obtain a reproduction of the original signal for each channel. The low pass filters exhibit a cutoff frequency lower than the lowest possible fundamental frequency component of either pulse train. Since the filters have a five pole response, the output of each filter is effectively the D. C. component of the Fourier Series that represents its respective input pulse train.

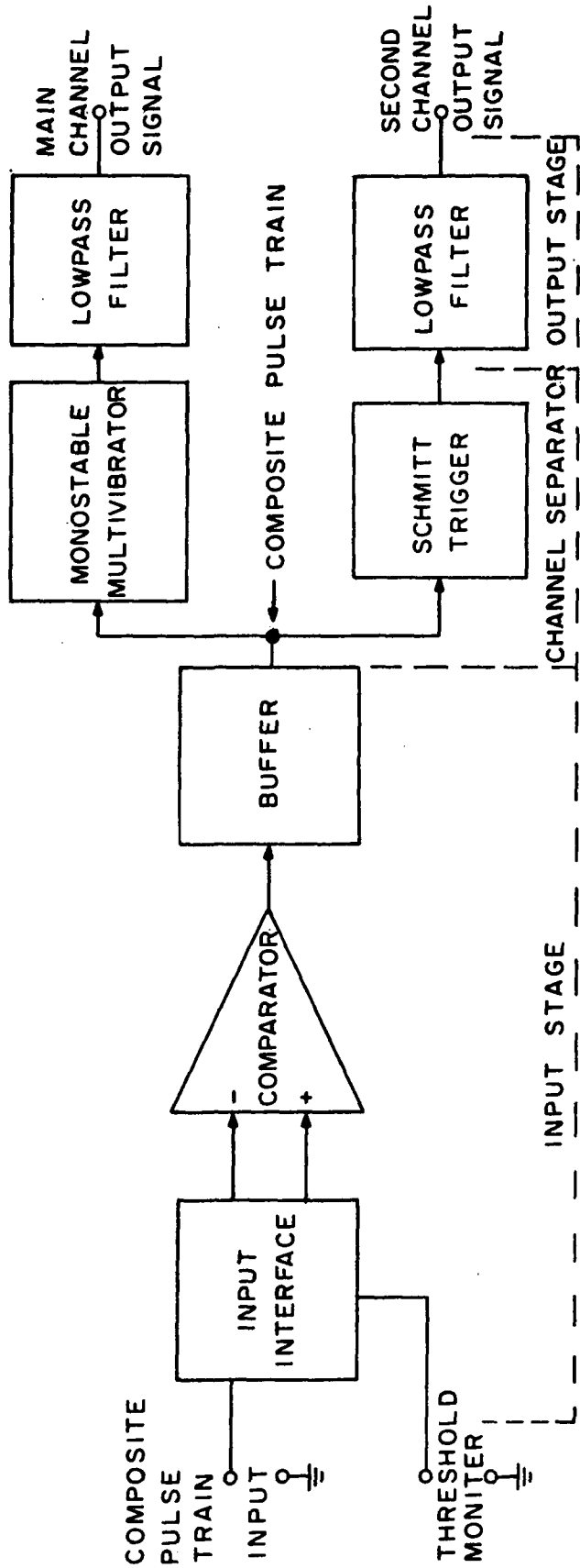

FIGURE 10
DEMODULATOR BLOCK DIAGRAM

5.2 The Input Stage

The schematic diagram of the input stage is shown in Figure 11. Switch S1 and potentiometer R4 are located on the front panel, and switch S1 is shown in the invert position. Switch S1 establishes the range of the input threshold voltage, and ensures that the pulses on the output side of the comparator are always positive sense referenced to ground. A double anode zener diode ZD4 protects the comparator from input voltages that may exceed its breakdown voltage specifications.

The comparator output is buffered to supply the appropriate amplitude pulse train to the channel separator stage. Transistor Q1 operates in a common base configuration as an active switch. Resistors R6 and R7 and zener diode ZD3 shift the level of the comparator output to drive transistor Q1. Diode D1 clamps the negative portion of the pulse train to ground.

The input stage provides a positive sense pulse train. Potentiometer R4 should be adjusted to minimize the effect of noise in the input pulse train. The input stage accepts any input pulse train whose peak to peak amplitude is greater than 20 millivolts or less than 10 volts thus eliminating the need for an amplifier for small inputs.

5.3 The Channel Separator Stage

Integrated circuit IC2 is a high level, transition sensitive dual one shot. This device contains two transition sensitive triggers TA and TB each followed by a monostable multivibrator.

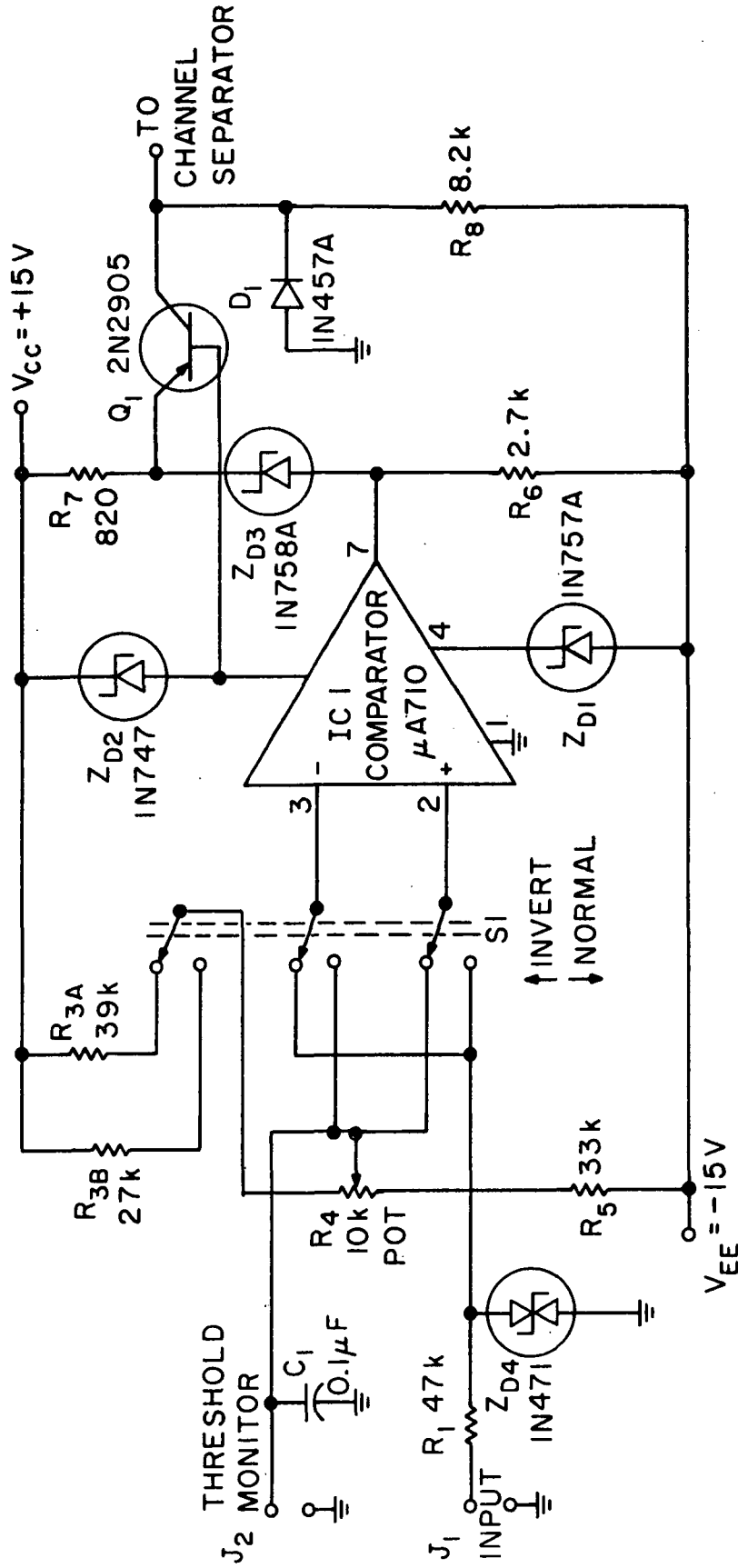

FIGURE 11
CIRCUIT SCHEMATIC FOR DEMODULATOR INPUT STAGE

The circuit schematic shown in Figure 12 uses the letters A and B to separate the terminals corresponding to the two one shots. The A one shot corresponds to the main channel, and generates a fixed width pulse coincident with the leading edge of every input pulse. The pulse width is fixed by the values of the timing components, resistor R9 and capacitor C2. At this point the main channel information is separated from the composite pulse train, and is referred to as the main channel pulse train. The B one shot corresponds to the second channel and functions as a Schmitt trigger. There are no timing components associated with the B one shot, and the transition sensitive input TB is bypassed. At this point the second channel information is represented by the same form as the composite pulse train, but is referred to as the second channel pulse train.

5.4 The Low Pass Filters

Since both filters use the same component values, only one filter is discussed, and the schematic diagram shown in Figure 13 may represent the filter corresponding to either channel. The filter may be described as a two pole Butterworth Active Filter with a gain of ten followed by a unity gain, three pole, one dB cutoff, Chebychev Active Filter. Cascading the filters in this manner provides the sharp cutoff necessary to ensure that ripple due to high duty cycle at low pulse repetition rate is attenuated at least forty dB.

The transfer function of the two pole Butterworth Active Filter is given in Equation (7).

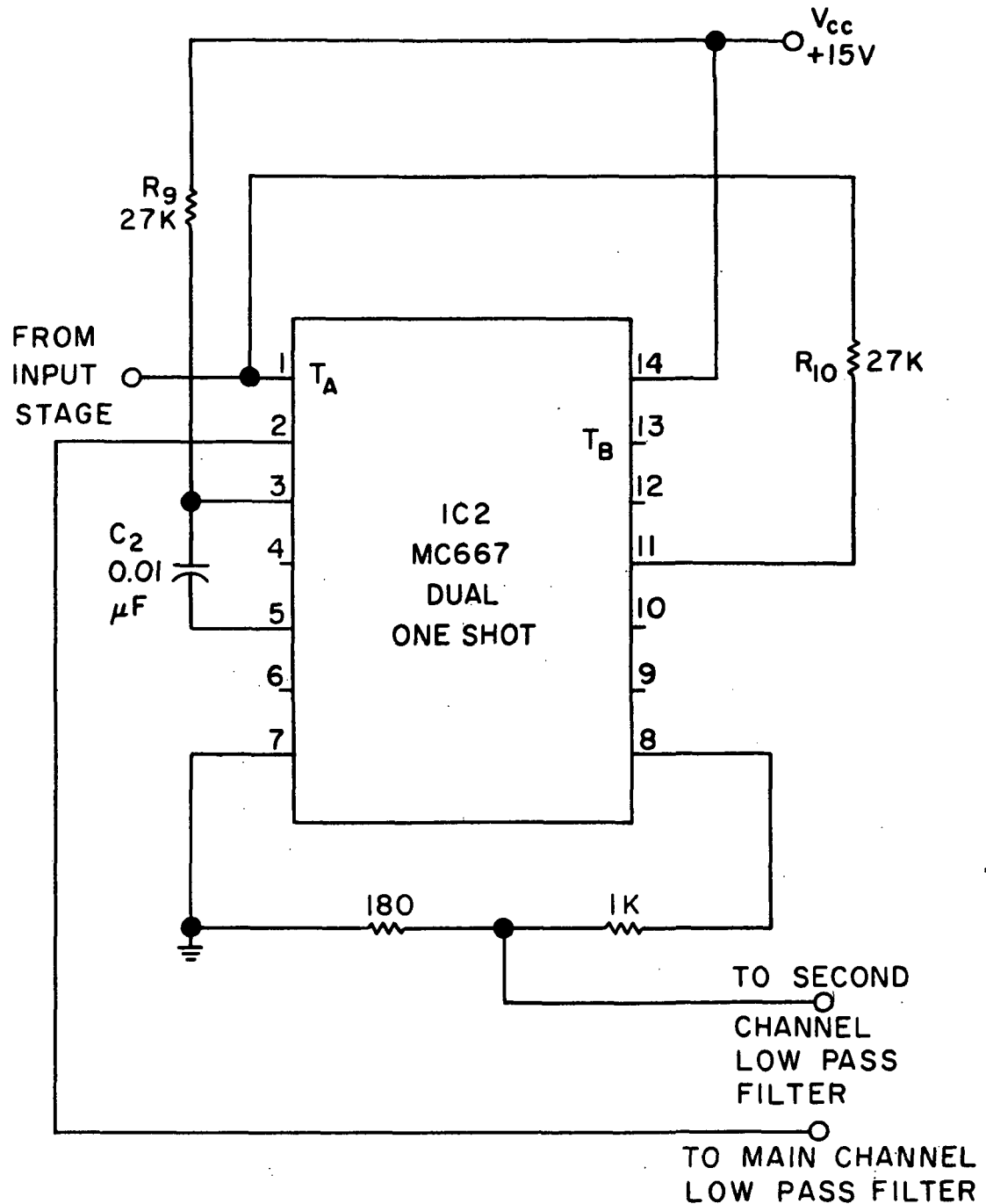

FIGURE 12
 CIRCUIT SCHEMATIC FOR DEMODULATOR
 CHANNEL SEPARATOR STAGE

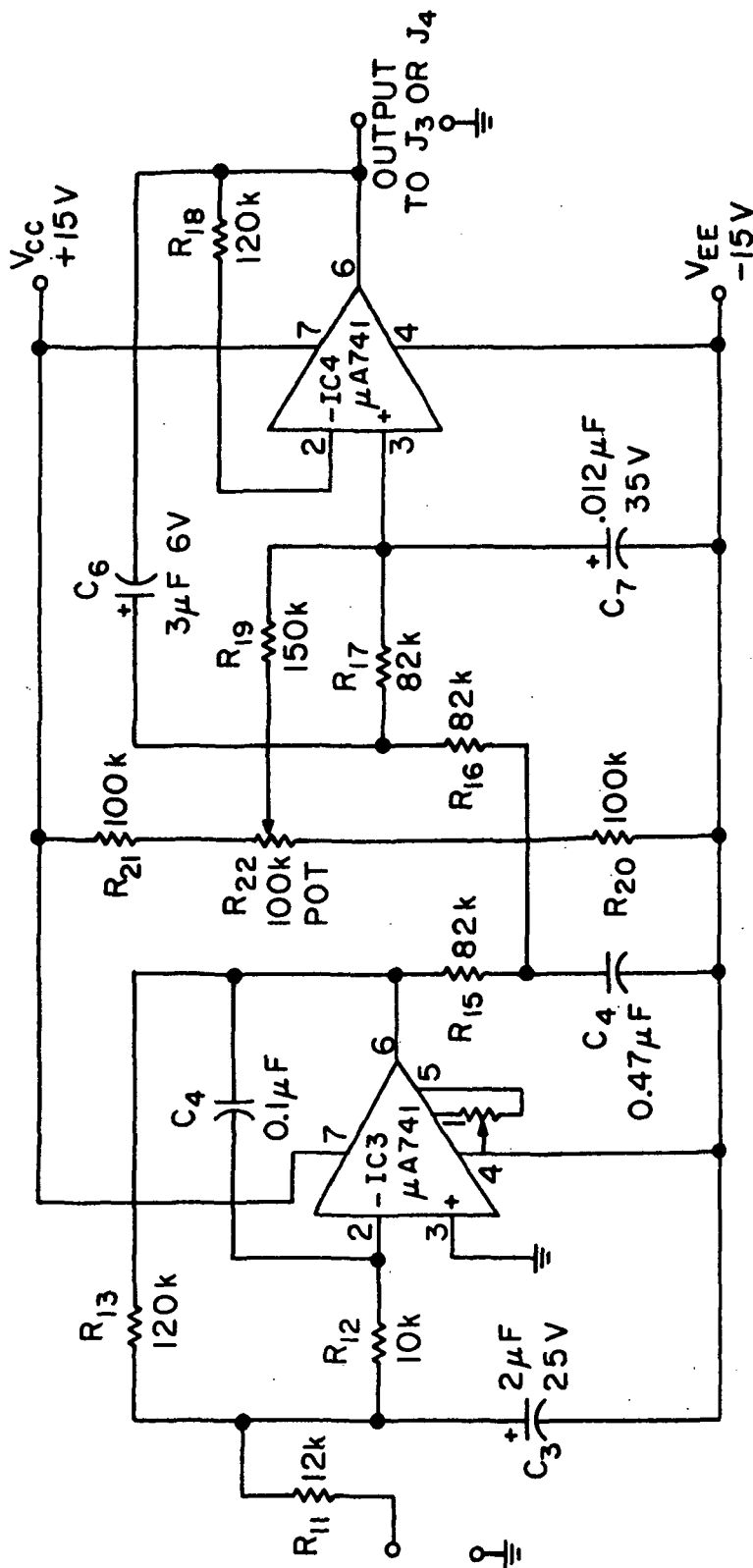

FIGURE 13
CIRCUIT SCHEMATIC FOR LOW PASS FILTER

$$\frac{V_o}{V_I} = \frac{-1/R_{11}R_{12}}{s^2 C_3 C_4 + s C_4 \left(\frac{1}{R_{11}} + \frac{1}{R_{12}} + \frac{1}{R_{13}} \right) + \frac{1}{R_{12}R_{13}}} \quad (7)$$

Since the cutoff frequency, gain, and type of response (maximally flat) are known, the normalized component values may be computed from the above equation. The component values may be changed without affecting the transfer function by multiplying each normalized resistor value and dividing each normalized capacitor value by the same factor. Trimpot R14 is included to balance offset voltages due to the operational amplifier I. C. 3.

The three pole Chebychev Active Filter exhibits one dB ripple in the passband, and one dB attenuation at the cutoff frequency. The transfer function of the filter is shown in Equation (8) with all resistors normalized to one ohm, and the cutoff frequency normalized to 1 Hz. The form of the denominator

$$\frac{V_o}{V_I} = \frac{1/C_7 C_6 C_5}{s^3 + 2s^2 \left(\frac{1}{C_6} + \frac{1}{C_5} \right) + \frac{3s}{C_6} \left(\frac{1}{C_7} + \frac{1}{C_5} \right) + \frac{1}{C_7 C_6 C_5}} \quad (8)$$

for a 1 dB Chebychev filter is given in Equation (9). By equating coefficients, the normalized values of the capacitors are obtained. The actual

$$\text{Denominator} = s^3 + 0.9885s^2 + 1.24s + 0.491 \quad (9)$$

components values may be obtained by multiplying the normalized resistor values (R15, R16, R17) by a factor (X), and dividing the capacitor values by the product of the factor (X) and the cutoff frequency. Resistor R18 minimized input offsets for op-amp IC4. Resistors R19, R29, and R21 and the front panel control R22 provide the DC voltage offset capability at the output terminal of op-amp IC4. This output terminal is the demodulated output and is connected to the appropriate output jack mounted on the rear panel.

Figure 14 shows the measured response of the cascaded filters as a function of frequency for a one volt peak to peak sine wave applied to the filter input. Some modifications in the filter response may be desirable at a later date depending on the type of information transmitted and the background noise level. As an example consider the composite pulse train at the demodulator input to be contaminated by noise bursts. If these noise bursts are of sufficient amplitude, the demodulator output appears as a low pass filtered pulse during the noise burst, thus destroying the signal information before, during, and after the noise burst. This occurs due to the filters 250 millisecond risetime response to a step function. Increasing the filter cut off frequency by changing the resistor values minimizes the signal loss before and after the noise burst, but this may also increase distortion at low pulse repetition rates.

The low pass filters provide the final stage of demodulation for both channels. The use of active filters eliminates the need for large inductors therefore conserving both the volume and the weight

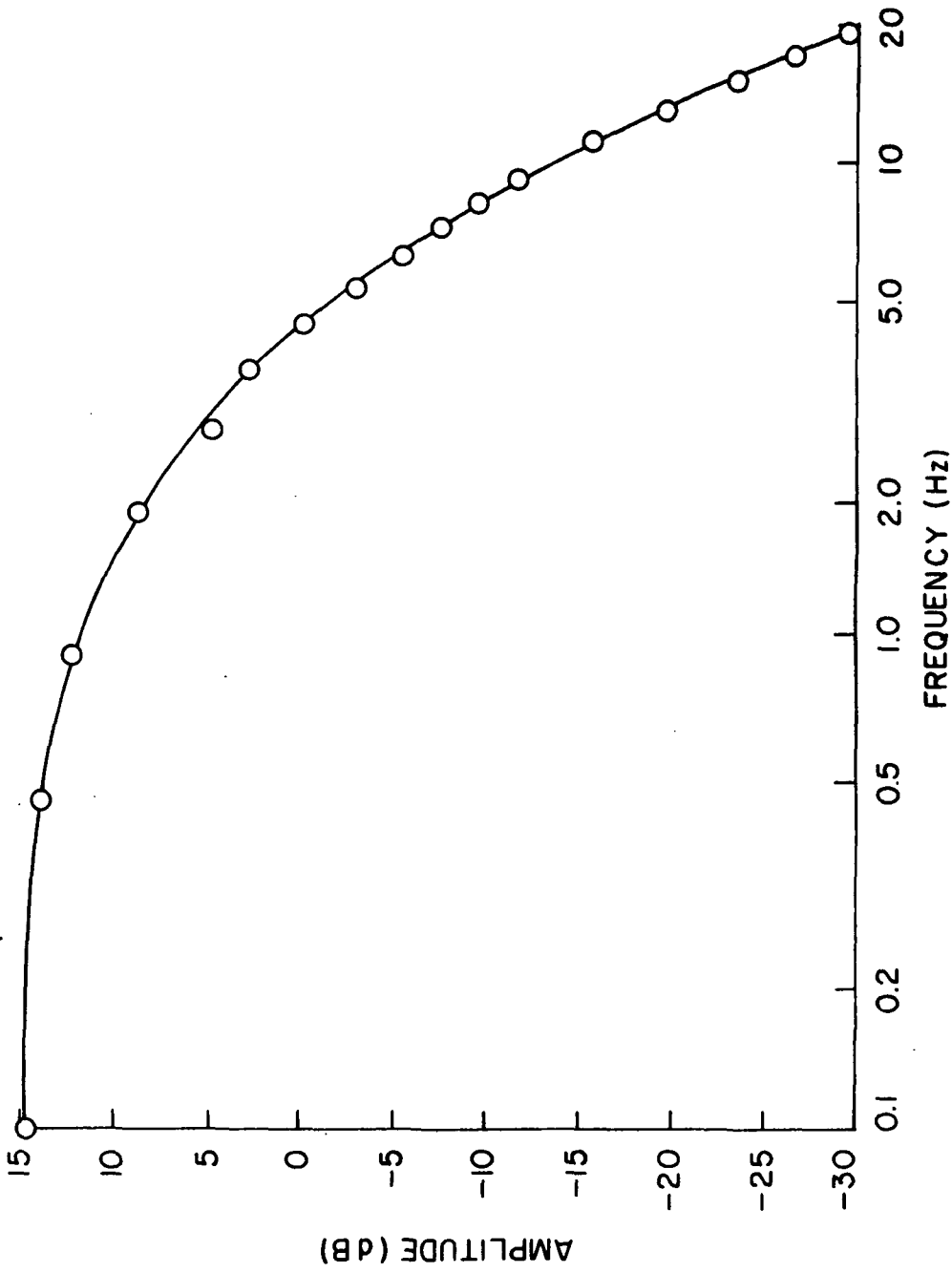

FIGURE 14

BODE PLOT OF AMPLITUDE vs FREQUENCY FOR THE LOW PASS FILTERS

of the demodulator unit. The filter circuit used exhibits a low output impedance, and includes a DC output offset control for each channel.

5.5 The Power Supply and Voltage Regulators

The circuit schematic for this section is shown in Figure 15. The unregulated power supply includes a standard full wave bridge rectifier (18DB3), and a Triad power transformer (F90X) one-quarter ampere fuse, the power switch (S2), and the pilot light. The 47 microfarad capacitors following the bridge rectifier provide ripple filtering prior to regulation.

The voltage regulator circuitry configuration is recommended by the manufacturer of the integrated circuits IC5 and IC6. The integrated circuit contains a voltage reference and an operational amplifier. An external voltage divider is used to compare the regulated output voltage to the internal voltage reference. The operation amplifier maintains the regulated output voltage constant through feedback provided by the voltage divider. The external pass transistor limits the power dissipation of the integrated circuits, and does not effect the output voltage since it is enclosed in the feedback loop. Both regulators include a trimpot adjustment to compensate for component tolerances and aging. The positive regulator is current limited to a maximum of 60 milliamperes. The regulators provide an output voltage that is very stable with temperature changes, and within limits may be considered independent of load current and unregulated power supply voltage.

5.6 Summary

The two channel demodulator described in this section performs satisfactorily over the temperature range of 0° to 70° centigrade. The unit is self sufficient since it contains its own power supply and voltage regulators. The adjustable input threshold control, and the pulse sense switch provide a flexible interface between the demodulator and the source of the input signal. Each channel is provided with a DC output voltage offset to facilitate data reduction. Future work may include the implementation of an automatic two channel calibrator.

BIBLIOGRAPHY

- Brokan, Paul A., "Simplify Three Pole Active Filter Design,"
E. D.N., December 15, 1970, 23-28 pp.
- Giles, James N., Fairchild Semiconductor Linear Integrated Circuits
Application Handbook, Mountain View, California: Fairchild
Semiconductor, 1967.
- Huelsman, L. P., Handbook of Operational Amplifier Active R. C.
Networks, Burr-Brown Research Corporation, 1966.
- Millman, Jacob and Herbert Taub, Pulse, Digital, and Switching
Waveforms, New York: McGraw-Hill Book Company, Inc.,
1965, 263-269 pp.
- Nichols, Myron H., and Lawrence L. Rauch, Radio Telemetry,
Second Edition, New York: John Wiley and Sons, Inc.,
1956.
- Scott, Michael M., J. Darryl Lieux, Robert D. Ricks and Michael
J. English, "A723 Precision Voltage Regulator Application
Notes," Fairchild Semiconductor, 1968.

APPENDIX

DERIVATION OF THE SIGNAL TO NOISE RATIO

Definitions:

- h = pulse amplitude
 τ_1 = pulse width
 τ_2 = pulse period referenced to leading edges
 F_c = bandwidth of system (including telemetry link)
 T_1 = $(\tau_{1 \max} - \tau_{1 \min})$ for full modulation by sine wave
 D = maximum duty cycle ratio = $(\frac{\text{PULSE WIDTH}}{\text{PULSE PERIOD}})_{\max}$
 F_1 = maximum P. R. F.
 F_2 = minimum P. R. F.
 N = R. M. S. noise voltage (white noise and A. M. ;
 $N = k(F_c)^{1/2}$)

Assumptions:

- A) Transmitter is off during pulse, and otherwise is on.
 B) Pulse slicing occurs at the half height point ($h/2$).
 C) Only R. M. S. quantities are used in S/N expression.

Main Channel Signal to Noise Ratio (Pulse Position Modulation)

$$S/N \text{ (Main Ch.)} = \frac{\Delta \tau_2 \text{ due to fully modulated signal R. M. S.}}{\Delta \tau_2 \text{ due to noise R. M. S.}}$$

$$\begin{aligned} \Delta \tau_2 \text{ (Full Modulation R. M. S.)} &= \frac{1}{2\sqrt{2}} \Delta \tau_2 \text{ (p to p)} \\ &= \frac{1}{2\sqrt{2}} \left(\frac{1}{F_2} - \frac{1}{F_1} \right) \end{aligned}$$

$$\Delta \tau_2 \text{ (Noise R. M. S.)} = N \div \left. \frac{dV}{dt} \right|_{\text{at half height point}}$$

$$\left. \frac{dV}{dt} \right|_{\text{at } (\frac{1}{2} h)} = 2 h \cdot F_c$$

$$S/N \text{ (Main Ch.)} = \frac{h F_c}{\sqrt{2} N} \left(\frac{1}{F_2} - \frac{1}{F_1} \right)$$

Second Channel Signal to Noise Ratio (Duty Cycle Modulation)

$$\text{Trailing Edge S/N} = \frac{\Delta \tau_1 \text{ due to fully modulated signal R. M. S.}}{\Delta \tau_1 \text{ due to noise R. M. S.}}$$

$$\begin{aligned} \Delta \tau_1 \text{ (full modulation R. M. S.)} &= \frac{\Delta \tau_1 (p - p)}{2 \sqrt{2}} \\ &= \frac{D}{2 \sqrt{2}} \left(\frac{1}{F_2} - \frac{1}{F_1} \right) \end{aligned}$$

$$\Delta \tau_1 \text{ (Noise R. M. S.)} = N \div \left. \frac{dV}{dt} \right|_{h/2}$$

$$\text{Trailing Edge S/N} = \frac{h F_c D}{\sqrt{2} N} \left(\frac{1}{F_2} - \frac{1}{F_1} \right)$$

$$S/N \text{ (second ch.)} = \text{R. M. S. value of [S/N leading edge and S/N trailing edge]}$$

$$= S/N \text{ (Main Ch.)} \left(\frac{1 + D^2}{2} \right)^{1/2}$$

$$= \frac{h F_c}{2N} (1 + D^2)^{1/2} \left(\frac{1}{F_2} - \frac{1}{F_1} \right)$$