

**NASA TECHNICAL
MEMORANDUM**

NASA TM X-68074

NASA TM X-68074

**CASE FILE
COPY**

**AN INTEGRAL TEST OF THE INELASTIC CROSS SECTIONS
OF Pb AND Mo USING MEASURED NEUTRON SPECTRA**

by D. F. Shook, D. Fieno, C. H. Ford,
and G. N. Wrights
Lewis Research Center
Cleveland, Ohio

TECHNICAL PAPER proposed for presentation at
Annual Meeting of the American Nuclear Society
Las Vegas, Nevada, June 18-22, 1972

AN INTEGRAL TEST OF THE INELASTIC CROSS SECTIONS OF
Pb AND Mo USING MEASURED NEUTRON SPECTRA

by D. F. Shook, D. Fieno, C. H. Ford, and G. N. Wrights

Lewis Research Center

SUMMARY

Comparison of measurements and calculations of fast neutron spectra from a radioactive neutron source inside spheres of Mo or Pb and from a cylindrical reactor containing a thick Pb or Mo reflector are used as a test of ENDF cross sections. The sphere leakage spectra were measured at a sphere-to-spectrometer distance of 2 meters using a ^{54}Ci spherical Am-Be neutron source. The Pb sphere was 38 cm in diameter providing a shell thickness of 4 mfp at 4 MeV. The Mo sphere contained powder and was 23 cm in diameter with a shell thickness of 0.74 mfp at 4 MeV. Reactor leakage spectrum measurements were made at the surface of the NASA ZP-1 reactor which is a cylindrical UO_2F_2 water solution reactor 25 cm in diameter and up to 76 cm high. Measurements were made of the bare reactor and with a Pb radial reflector 21 cm thick and with a metallic Mo radial reflector 10 cm thick.

The leakage spectrum measurements were made in the energy range 0.5 to 11 MeV using a liquid scintillator proton recoil spectrometer. The spectra were calculated using the S_n formulation of the neutron transport equation. The flux at the detector was calculated using the known source strength in the case of the sphere measurements, and per watt of power in the case of the reactor measurements. For Mo, ENDF/B1111 microscopic cross sections were used and for Pb, ENDF/B43 cross sections were used. Tests of the adequacy of the scattering and angular quadrature order have been made.

The results for the sphere measurements and calculations show that in the case of the thin Mo sphere there is agreement between the calculation and measurement. The Pb calculation is much lower than the measurement except at the highest neutron energy.

In the case of the reactor spectra the use of two-dimensional calculations results in spectra that are in good agreement with the measurements at the surface of the bare reactor indicating that the reactor source is reasonably well known. Significant differences in leakage spectrum shape are observed for both Mo and Pb reflectors suggesting that there are large uncertainties in the inelastic cross sections for Pb and some for Mo.

INTRODUCTION

Measured and calculated fast neutron spectra in the energy range 0.5 to 11 MeV transmitted by lead and molybdenum shields are used as a test of existing ENDF/B cross sections for these materials. The elements Pb and Mo are tested because of their possible use in compact reactors and minimum weight shields for space power applications. Two sets of measurements and calculations were made utilizing different source spectra. The first set of measurements were made by placing an Am-Be (α , n) neutron source inside spheres of the elements tested. The sphere leakage spectra were measured at a distance of 2 meters using a large liquid scintillator. With this simple geometry it was possible to make transport calculations with a large number of energy groups and to reduce the uncertainty in the calculation to essentially the input cross sections.

In the second set of measurements the elements tested were used as radial reflectors for a small cylindrical homogeneous reactor. The spectrum measurements were made close to the outer surface of the reflector to minimize ray effects in the two-dimensional transport calculations.

Experiment

The methods used for the sphere measurements are the same as reported in reference 1. The sphere leakage spectra were measured at

a sphere-to-spectrometer distance of 2 meters with both the sphere and spectrometer located 160 cm above the floor of a large room, as shown in figure 1. Background due to neutrons scattered into the spectrometer from the walls and supporting structure was accounted for using a shadow cone. This correction to the measurement was negligible at the highest neutron energies measured but increased to 30 percent at the lowest energy measured. The measurements were made with a large spherical Am-Be neutron source containing 54 Ci of ^{241}Am (16.7 g) and 66.8 grams of Be in a net volume of 84.3 cm^3 . The output of the source was $(1.30 \pm 0.08) \times 10^8$ neutrons per second. The outside diameter of the source is 6.096 cm and includes two stainless steel containment shells, one 0.140-cm thick and the other 0.152-cm thick. The spherical cavity for the source material is 5.462 cm inside diameter. The Mo sphere used in the measurements is 23 cm in diameter and contains Mo powder with a density of 3.73 g/cc providing a shell thickness of 0.74 mfp at 4 MeV. The Pb sphere was 38 cm in diameter providing a shell thickness of 4 mfp at 4 MeV. The isotopic composition of the Pb in the sphere and also the reflector was close to that of natural Pb. The abundances are 51.37 percent Pb 208, 20.50 percent Pb 207, 26.83 percent Pb 206, and 1.29 percent Pb 204.

The neutron spectra were measured using a 5 by 5 cm NE213 liquid scintillator proton recoil spectrometer. Pulse shape analysis and two parameter data acquisition were used to discriminate against γ ray pulses. A description of the spectrometer and calibration procedures are contained in reference 2. For a scintillator as large as that used here, care must be exercised in determining the neutron spectra from the measured proton recoil spectra due to multiple scattering and carbon interaction in the scintillator.

In the present work the measured proton recoil spectra were reduced using the measurements of Verbinski, et al. (ref. 3) and the unfolding code, Ferdor (ref. 4). Since the present measurements are in an essentially parallel beam geometry, the reference 2 response functions are directly applicable. To assure that small differences in scintillator

size or spectrometer resolution did not cause a significantly different response matrix fit, monoenergetic spectra were measured at 2.8 and 14.7 MeV and detailed comparison satisfactorily made with the reference 2 response functions.

The reactor leakage spectra measurements were made with a 1.2 cm diameter by 1.3 cm long NE218 liquid scintillator positioned with the curved surface 3 cm from the reactor surface at the center. The neutron spectra were obtained from the measured proton recoil distribution using differentiation analysis as outlined in reference 2.

The reactor, as shown in figure 2 and described in reference 5, was cylindrical, 25 cm in diameter and 50 cm high and contained fully enriched uranium as a dilute solution ($H/X = 237$) of uranyl fluoride in water. The reactor was contained in a stainless steel tank having 0.159 cm thick walls. Measurements were also made with full radial reflectors of lead or molybdenum surrounding the reactor. The metallic molybdenum reflector was 10.1 cm thick and reactor and reflector was 72 cm high. The lead reflector was 21 cm thick and reactor and reflector was 43 cm high.

The room background was determined to be less than 1 percent of the foreground for the spectrum measurements at the surface of the reflectors. This was determined from background measurements at 1 and 2 meters from the reactor utilizing a shadow cone. There is a component of the measured background due to collisions in the photomultiplier tube that would not be independent of source distance, but this was not evident in the measurements at 1 and 2 meters. Single collisions in the photomultiplier tube indicate that this flux is less than 5 percent of the foreground.

TRANSPORT CALCULATIONS

Sphere Leakage Spectrum

Multigroup calculations using the S_n method were performed to obtain the sphere leakage spectrum. The calculations were performed in

spherical geometry with shells of the test material enclosing the Am-Be neutron source. The Am-Be neutron source and its stainless steel containers were explicitly included in the calculations. The calculations were of the fixed source type using an input spectrum uniformly distributed throughout the source region. Fifty-one energy groups were used. The first 49 energy groups had a lethargy interval of 0.1 and covered the energy range of 14.92 to 0.11 MeV.

Microscopic cross section data for the test materials (Mo and Pb) were obtained from the ENDF/B data files for the group split used.

The ENDF/B cross sections used for lead were issued as ENDF/B material number 43. The data for ENDF/B43 were obtained from file 26 of the Aldermaston evaluation. For Mo ENDF/B1111 cross sections were used. The Mo data were originally compiled in 1966 by Pennington and Gajniak (ref. 6) and issued as ENDF/B material number 1025. The primary source of information for this evaluation by Pennington and Gajniak is the evaluation prepared by Schmidt (ref. 7).

The Mo cross sections have been further revised and issued as ENDF/B material number 1111. A number of changes in the ENDF/B number 1025 evaluation were made. The most important change for the purpose of this study was in the high energy (n, γ) cross sections. These (n, γ) cross section data were reduced in value so that computed central reactivity worths in fast assemblies correspond to experimental reactivity determinations.

In our calculations the elastic scattering cross sections for Mo included both the P_0 and P_1 down-scattering transfer cross sections; for lead elastic scattering was treated through the P_3 order. For Mo and Pb the inelastic scattering cross sections, as well as any ($n, 2n$) cross sections, were assumed to have only the P_0 component of the down-scattering transfer cross sections.

Calculations for the Mo experiment indicated that a P_1 treatment of elastic scattering was adequate for computing the neutron leakage spectrum. Calculations in which the elastic scattering is treated through the P_1 order and through the P_3 order differ by less than

1.5 percent for groups 15 through 49 (3.3 to 0.11 MeV). The difference at group 5 (10 MeV) is about 4 percent.

Along with the elastic scattering order, the S_n quadrature order is important. The calculations reported herein used an S_{16} Gauss-Legendre quadrature set. This set was found to give an adequate description of the leakage spectrum from the spherical shells of the test materials in that a higher order S_{32} calculation differs by less than 1 percent for all groups.

The calculations reported herein are based on the total number of neutrons emitted by the Am-Be source ($1.30 \pm 0.08 \times 10^8$ neutrons/sec).

The calculated flux per MeV at 2 meters is folded with the resolution function of the spectrometer using a modification of the smoothing subroutine in O5S (ref. 8). Thus, the comparison of the calculated fluxes with the measured fluxes is on an absolute basis with no normalization required.

Reactor Leakage Spectrum

Multigroup two-dimensional calculations using the S_n method were performed to obtain the leakage spectrum for the three critical fuel solution reactor configurations considered. The two-dimensional calculations were performed in cylindrical (r-z) geometry using DOT (ref. 9). Thirty-eight energy groups were used to describe the neutron leakage spectrum for the experiments considered. The first 27 groups had a lethargy width of 0.1 and covered the energy range from 14.92 to 1.00 MeV. The next six groups covered the energy range down to 0.11 MeV and the remaining groups covered the range of 0.11 to 0 MeV.

The calculations for the three critical reactor configurations are based on a reactor power of 1 watt. The flux per MeV is calculated at the reactor midplane at a radial position of 3.175 cm ($1\frac{1}{4}$ in.) from the reactor tank for the unreflected reactor or from the Mo or Pb reflector for the reflected reactors. In order to compare the calculations with the measured spectra, the resolution function of the spectrometer is

folded with these calculated multigroup fluxes as in the case of the sphere calculations.

Microscopic cross section data for the Mo and Pb reflectors were obtained from the ENDF/B data files (ENDF/B1111 for Mo, ENDF/B43 for Pb) while the cross section data for the material components of the fuel solution and containment tank were obtained from the GAM-II (ref. 10) and GATHER-II (ref. 11) data files. The two-dimensional calculations were performed with elastic scattering treated through P_3 and the angular quadrature through S_6 .

RESULTS AND DISCUSSION

Bare Source

The measured and calculated (α , n) source spectrum is shown in figure 3 and has been discussed in reference 1. A measured spectra for a small (α , n) source was used as input for transmission through the larger source. The comparison is generally good but the calculation has a few percent less total flux above 7 MeV and smoothes out the measured shape changes in this energy region. The (α , n) spectra is not expected to have abrupt changes in shape in this region but it does have more structure than can be represented by the particular multigroup structure used. At energies less than 7 MeV the agreement between the calculation and measurement is quite satisfactory.

Mo Sphere

The measured and calculated leakage spectrum from a thin Mo sphere containing the (α , n) source is shown in figure 3. The agreement between experiment and calculation is in general satisfactory with the calculation slightly higher than the measurement around 1.0 MeV neutron energy. Shape differences between measured and calculated leakage spectra for a thick molybdenum reflector on the solution reactor were observed below 5 MeV and are shown in figure 7.

Pb Sphere

The measured and calculated leakage spectrum from the natural lead sphere is shown in figure 3. A comparison between the two spectra indicates that the calculation is generally lower than the measurement. The agreement is particularly poor at 2.0 MeV where the calculated flux is only about 50 percent of the measured flux. Since the flux at this low energy depends not only on the inelastic removal but on the inelastic transfer cross sections from higher energies, it is difficult to determine the origin of such a large discrepancy from this measurement. A spectrum measurement and calculation made at ORNL (ref. 12) also shows a significant undercalculation of the flux around 2 MeV. Since the ORNL results depend only on the total cross section, they indicate that a part of the undercalculation around 2 MeV for this experiment is because the cross sections are too high in this energy range.

Bare Reactor Leakage Spectrum

The interpretation of the Pb and Mo reflector leakage spectrum is more complex than the sphere spectra because of the two-dimensional geometry and the presence of the reactor core materials of hydrogen, oxygen and small amounts of U^{235} and fluorine. To aid in the interpretation a measurement and calculation of the bare core leakage spectra was made. The measured and calculated spectra are shown in figure 4. The agreement between the experiment and the DOT calculation is seen to be generally satisfactory with the calculation slightly lower than the measurement.

Mo Reflected Reactor Leakage Spectrum

The measured and calculated leakage spectrum at 3 cm from the surface of the molybdenum reflected reactor is shown in figure 5. A comparison of the results in the figure show good agreement between

the transport calculations and measurement at energies greater than 6 MeV but significant shape difference at energies less than 6 MeV. These shape differences were not apparent in the sphere experiment so they could be due in part to processes occurring above a neutron energy of 10 MeV where there are no neutrons in the ${}^9\text{Be}(\alpha, n)$ source spectra. An additional factor is that the Mo reflector is much thicker than the Mo shell used in the sphere measurements.

Pb Reflected Reactor Leakage Spectrum

The measured and calculated leakage spectrum at 3 cm from the surface of the natural Pb reflected reactor is shown in figure 6. A comparison of the results in the figure show a discrepancy exists between the transport calculation and the measurement that is similar to the sphere measurement (see fig. 3). The large discrepancy in the energy range 1 to 2 MeV evident in the sphere measurement is, also present in this measurement.

REFERENCES

1. D. F. Shook, D. Fieno, C. H. Ford, and R. L. Alexander, Proceedings of the Third Conference on Neutron Cross Sections and Technology, AEC-CONF-710301, vol. 1 (1971), p. 98.
2. D. Shook, "A Small Differential Liquid Scintillator Neutron Spectrometer," TM X-52828, National Aeronautics and Space Administration (1970).
3. V. V. Verbinski, W. R. Burrus, T. A. Love, W. Zobel, N. W. Hill, and R. Textor, Nucl. Inst. Methods, **65**, 8 (1968).
4. W. R. Burrus, "Utilization of a Priori Information by Means of Mathematical Programming in the Statistical Interpretation of Measured Distributions," ORNL-3743, NASA CR-63442, Oak Ridge National Laboratory (1965).

5. T. A. Fox, R. A. Mueller, and D. Fieno, "Criticality Study of NASA Solution Reactors with 25.4-Centimeter-Diameter Cylindrical Stainless Steel Tanks," TM X-2381, National Aeronautics and Space Administration (1971).
6. E. M. Pennington and J. C. Gajniak, "Compilation of ENDF/B Data for Magnesium, Titanium, Vanadium, Molybdenum, and Gadolinium," ANL-7387, Argonne National Laboratory (1968).
7. J. J. Schmidt, "Neutron Cross Sections for Fast Reactor Materials, Part I: Evaluation," KFK-120, Institut fuer Neutronenphysik und Reskortechnik (1966).
8. R. E. Textor and V. V. Verbinski, "O5S, A Monte Carlo Code for Calculating Pulse Height Distributions Due to Monoenergetic Neutrons Incident on Organic Scintillators," ORNL-4160, Oak Ridge National Laboratory (1968).
9. F. R. Mynatt, "A Users Manual for DOT: A Two-Dimensional Discrete Ordinates Transport Code with Anisotropic Scattering," K-1694, Union Carbide Corp. (1967).
10. G. D. Joanou and J. S. Dudek, "GAM-II, A β_3 Code for the Calculation of Fast Neutron Spectra and Associated Multigroup Constants," GA-4265, General Atomic (1963).
11. G. D. Joanou, C. V. Smith, and H. A. Vieweg, "GATHER-II, An IBM-7090 FORTRAN-II Program for the Computation of Thermal Neutron Spectra and Associated Multigroup Cross Sections," GA-4132, General Dynamics Corp. (1963).
12. C. E. Clifford, E. A. Straker, F. J. Muckenthaler, V. V. Verbinsky, R. M. Freestone, K. M. Henry, and W. R. Burrus, Nucl. Sci. Eng., 27, 299 (1967).

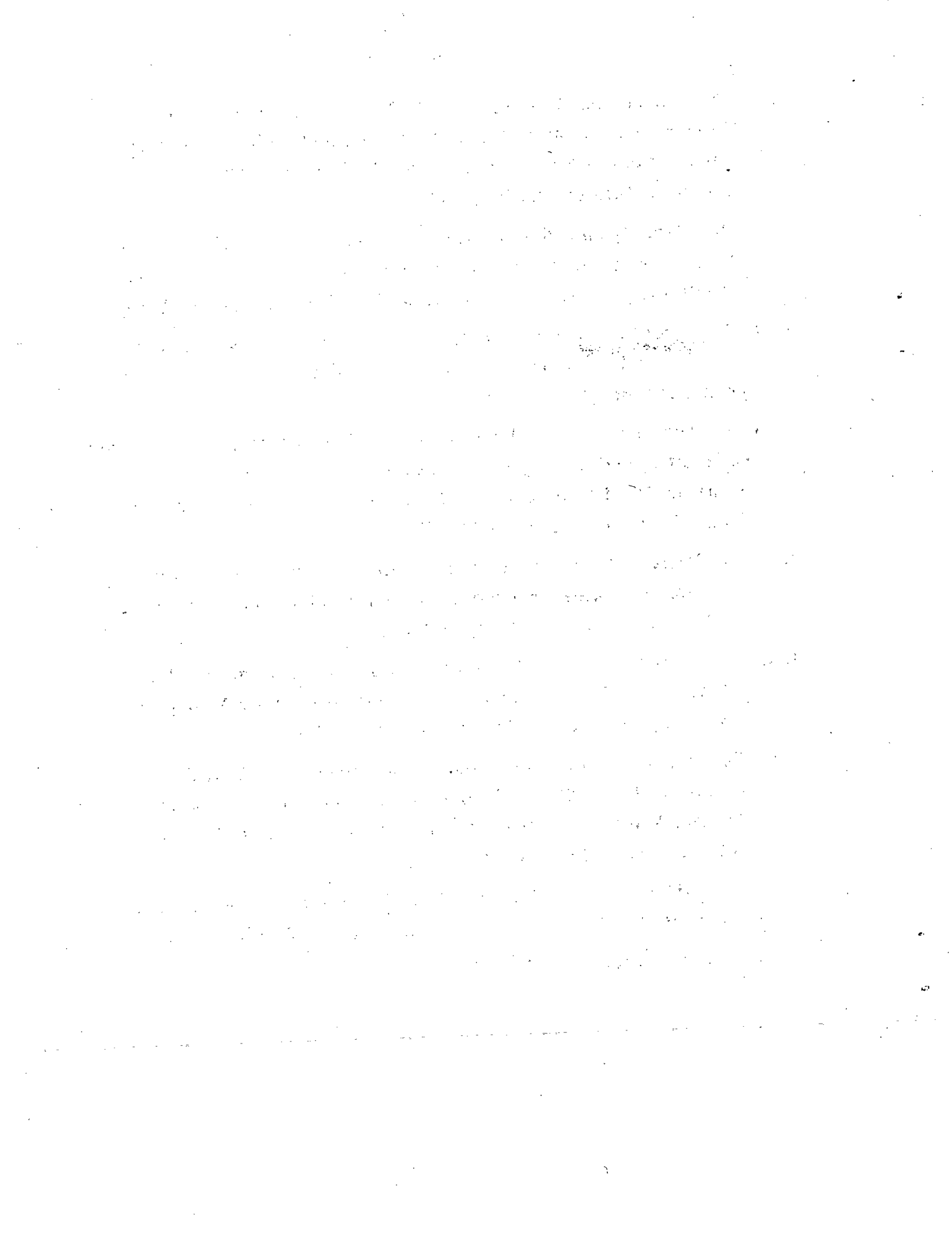

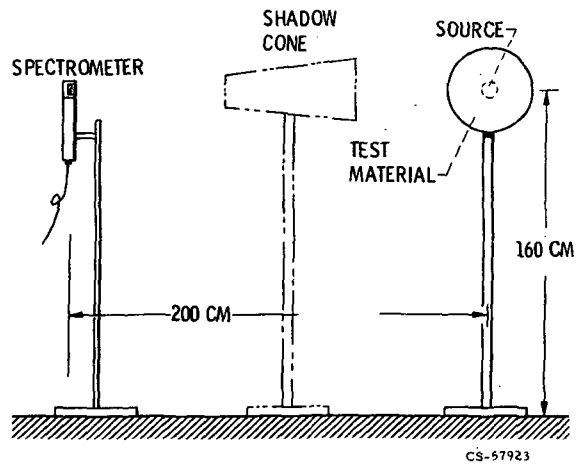

Figure 1.

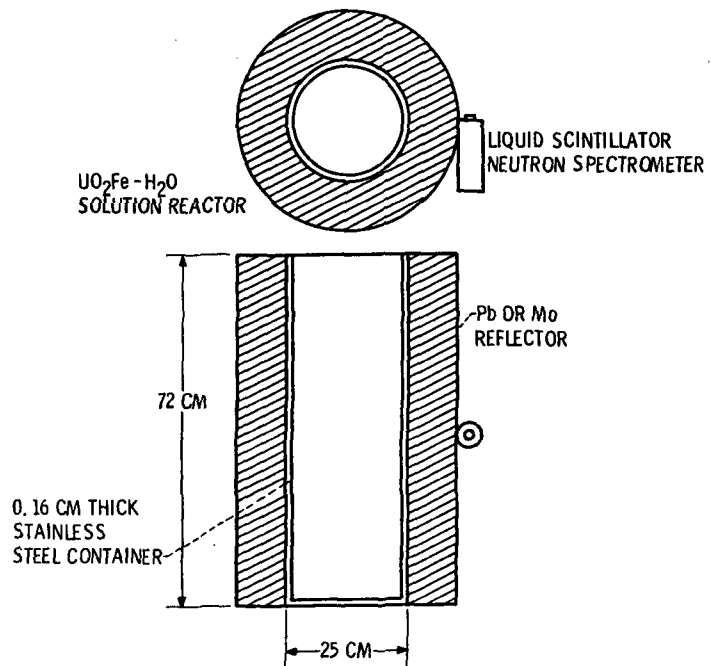

Figure 2. - Reactor leakage. Leakage spectrum measurement.

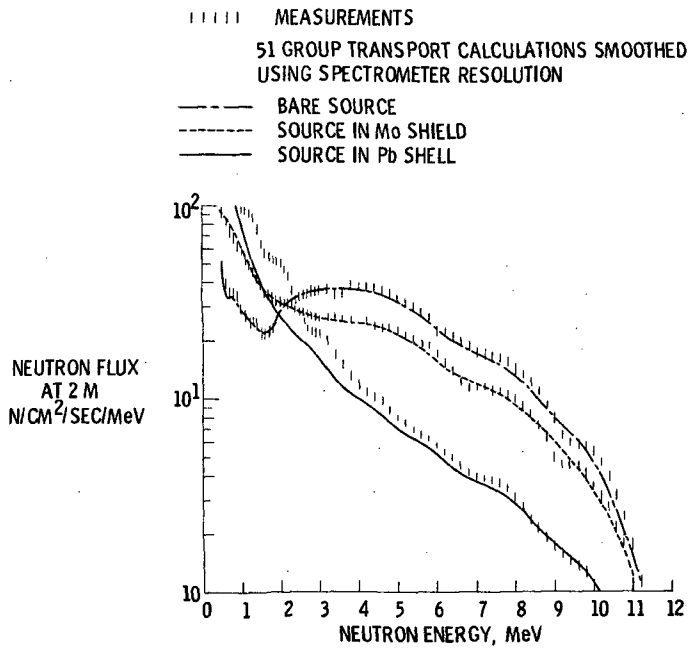

Figure 3. - Leakage spectrum for AmBe source enclosed by a Pb and a Mo shell.

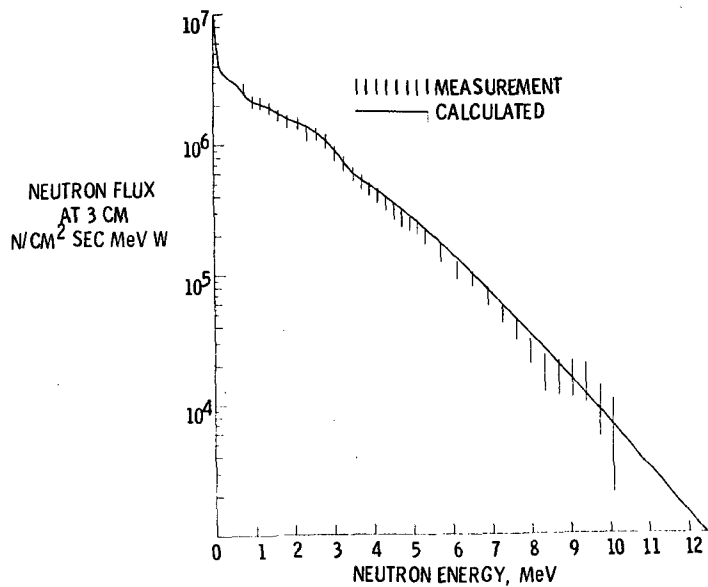

Figure 4. - Leakage spectrum at surface of bare cylindrical solution reactor.

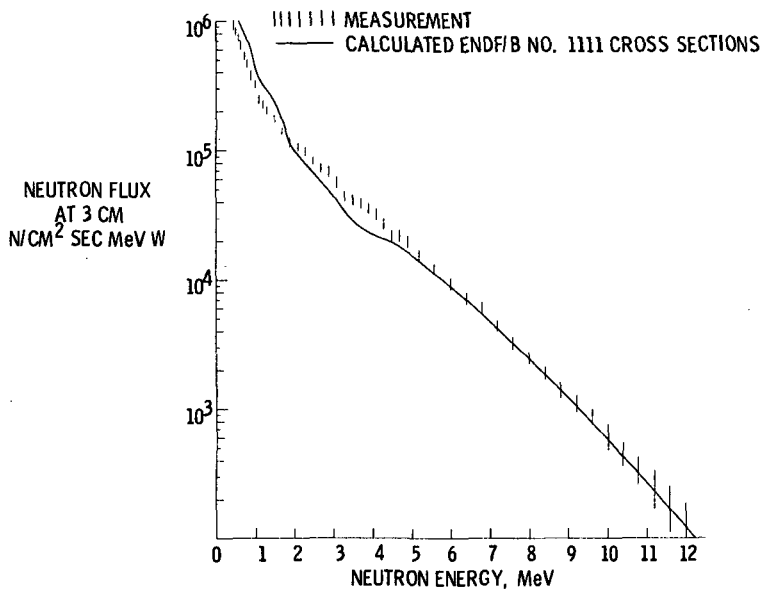

Figure 5. - Leakage spectrum at surface of molybdenum reflected reactor.

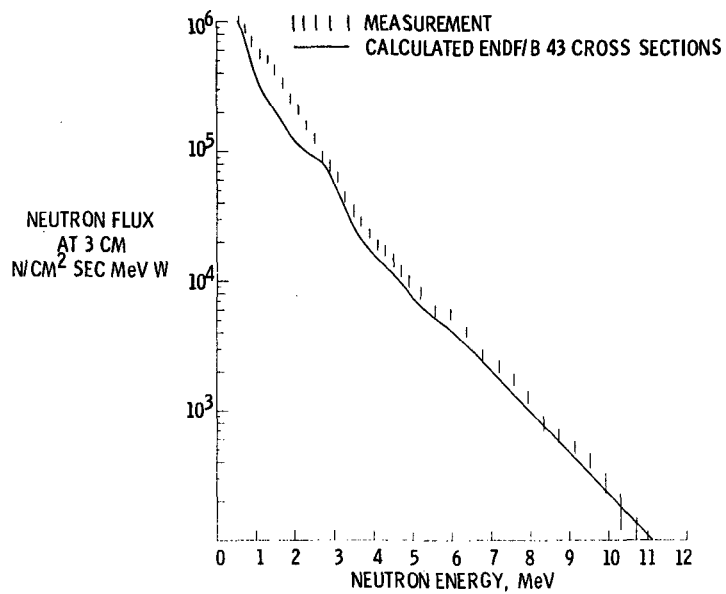

Figure 6. - Leakage spectrum at surface of lead reflected reactor.