

NASA CONTRACTOR
REPORT

NASA CR-61386

CASE FILE
COPY

SKYLAB EXPERIMENT PERFORMANCE
EVALUATION MANUAL

Appendix K: Experiment S009 Nuclear
Emulsion (MSFC)

By J. E. Meyers
Teledyne Brown Engineering Company
Huntsville, Alabama

March 31, 1972

Prepared for

NASA-GEORGE C. MARSHALL SPACE FLIGHT CENTER
Marshall Space Flight Center, Alabama 35812

1. REPORT NO. NASA CR-61386		2. GOVERNMENT ACCESSION NO.		3. RECIPIENT'S CATALOG NO.	
4. TITLE AND SUBTITLE Skylab Experiment Performance Evaluation Manual /Appendix K: Experiment S009 Nuclear Emulsion (MSFC)				5. REPORT DATE March 1972	
				6. PERFORMING ORGANIZATION CODE	
7. AUTHOR(S) J. E. Meyers				8. PERFORMING ORGANIZATION REPORT #	
9. PERFORMING ORGANIZATION NAME AND ADDRESS Teledyne Brown Engineering Company Huntsville, Alabama				10. WORK UNIT NO.	
				11. CONTRACT OR GRANT NO. NAS8-21804	
12. SPONSORING AGENCY NAME AND ADDRESS National Aeronautics and Space Administration Washington, D. C. 20546				13. TYPE OF REPORT & PERIOD COVERED Contractor Report	
				14. SPONSORING AGENCY CODE	
15. SUPPLEMENTARY NOTES Prepared for Astronautics Laboratory, Science and Engineering					
16. ABSTRACT This appendix contains a series of analyses for Experiment S009, Nuclear Emulsion (MSFC), to be used for evaluating the performance of the Skylab corollary experiments under preflight, inflight, and post-flight conditions. Experiment contingency plan workaround procedure and malfunction analyses are presented in order to assist in making the experiment operationally successful.					
17. KEY WORDS Skylab Experiments			18. DISTRIBUTION STATEMENT Unclassified - Unlimited <i>Marie M Thompson</i>		
19. SECURITY CLASSIF. (of this report) Unclassified		20. SECURITY CLASSIF. (of this page) Unclassified		21. NO. OF PAGES 86	22. PRICE \$3.00

ACKNOWLEDGEMENTS

The appendices to this manual are prepared by the following personnel:

Appendix M: Thomas, O.H., Experiment S-150, Galactic X-Ray Mapping, Teledyne Brown Engineering Company, Huntsville, Alabama, 1-14-72.

Appendix N: Purushotham, K.S., Experiment S-183, Ultraviolet Panorama, Teledyne Brown Engineering Company, Huntsville, Alabama, 3-9-72.

Appendix R: Tonetti, B.B., Experiment T-020, Foot Controlled Maneuvering Unit, Teledyne Brown Engineering Company, Huntsville, Alabama, 3-31-72.

Appendix K: Meyers, J.E., Experiment S-009, Nuclear Emulsion, Teledyne Brown Engineering Company, Huntsville, Alabama, 3-31-72.

APPENDIX K. EXPERIMENT S-009, NUCLEAR EMULSION (MSFC)

March 31, 1972

Prepared By:

J. E. Meyers

TABLE OF CONTENTS

	Page
SECTION I.	Experiment S-009, Nuclear Emulsion Pre-Flight Operations Evaluation Analysis..... K-7
SECTION II.	Experiment S-009, Nuclear Emulsion Interface Block Diagram..... K-26
SECTION III.	Experiment S-009, Nuclear Emulsion Systems Diagram..... K-28
SECTION IV.	Experiment S-009, Nuclear Emulsion Data Requirements Summary..... K-30
SECTION V.	Experiment S-009, Nuclear Emulsion Data Request Forms..... K-32
SECTION VI.	Experiment S-009, Nuclear Emulsion Engineering Change Requests..... K-42
SECTION VII.	Experiment S-009, Nuclear Emulsion Evaluation Sequence..... K-44
SECTION VIII.	Experiment S-009, Nuclear Emulsion Malfunction and Contingency Plan Outline..... K-59
SECTION IX.	Experiment S-009, Nuclear Emulsion Malfunction Analysis..... K-69
SECTION X.	Conclusions and Recommendations..... K-71
REFERENCES K-73

LIST OF ILLUSTRATIONS

Figure	Title	Page
K-1.	Experiment S-009, Nuclear Emulsion Functional Block Diagram.....	K-22
K-2.	Experiment S-009, Nuclear Emulsion Interface Block Diagram and Definition	K-27
K-3.	Experiment S-009, Nuclear Emulsion Systems Diagram.....	K-29

LIST OF TABLES

Table	Title	Page
K-I.	Experiment S-009, Nuclear Emulsion Pre-flight Evaluation Analysis.....	K-8
K-II.	Experiment S-009, Nuclear Emulsion Data Requirement Summary	K-31
K-III.	Experiment S-009, Nuclear Emulsion Evaluation Sequence.....	K-45
K-IV.	Experiment S-009, Nuclear Emulsion Malfunction and Contingency Plan Outline - Experiment Preparation (P).....	K-60
K-V.	Experiment S-009, Nuclear Emulsion Malfunction and Contingency Plan Outline - Experiment Operation (O)	K-64
K-VI.	Experiment S-009, Nuclear Emulsion Malfunction and Contingency Plan Outline - Experiment Termination (T)	K-68

DEFINITION OF SYMBOLS

Symbol	Definition
AM	Airlock Module
cb	circuit breaker
ccw	counter clockwise
Compt.	Compartment
Condr.	Conditioner
CM	Command Module
DMA	Abrams Motor Manufacture model designation
FBD	Function Block Diagram
FO	Functional Objective
FOV	Field of View
Fwd.	Forward
GMT	Greenwich Mean Time
HOSC	Huntsville Operations Support Center
LAT	Lattitude
MDA	Multiple Docking Adapter
MDAC-ED	McDonnell Douglas Astronautic's Corporation - Eastern Division
MSC	Manned Spacecraft Center
MSFC	Marshall Space Flight Center
NRL	Naval Research Laboratory
OA	Oribtal Assembly

DEFINITION OF SYMBOLS (Continued)

Symbol	Definition
OMSF	Office of Manned Space Flight
OWS	Orbital Workshop
P	Period Adjust readout
P_{fn}	Net Probability of Failure
P_{ft}	Total Probability of Failure
PI	Principle Investigator
PLT	Pilot
P_s	Probability of Success
SAA	South Atlantic Anomaly
SC	Stromberg-Carlson
SL	Skylab
STS	Structural Transisition
TCS	Temperature Control System
Temp	Temperature
S3 through S6	Limit Switches
Uplink	Transmit data from the ground to the Orbital Assembly
Z/LV(E)	Z axis is pointed to the Earth's local verticle.

SECTION I.

EXPERIMENT S-009, NUCLEAR EMULSION PRE-FLIGHT
OPERATIONS EVALUATION ANALYSIS

TABLE K-1. EXPERIMENT S-009, NUCLEAR EMULSION PRE-FLIGHT OPERATION EVALUATION ANALYSIS (Sheet 1 of 14)

FUNCTIONAL BLOCK NUMBER AND TITLE	EXPECTED RANGE AND DIMENSION OF VARIABLES		CRITICALITY CATEGORY NUMBER*	REMARKS
	MIN.	NOM. MAX.		
3.0 Analyze and predict Skylab Experiment S-009, Nuclear Emulsion, facet performance profile.			N/A	Refer to functional item 3.1.
3.1 Make explicit statements about objectives in qualitative and quantitative terms.			N/A	Refer to functional item 3.1.1.
3.1.1 Specify duration that the experi- ment is required to operate and provide useful information.	23 days	25.5 days 28 days	N/A	The experiment will be exposed continuously during the SL-1/SL-2 mission. It is desired to begin the experiment as soon as possible, but no later than 5 days after flight carrier launch. Reference documents 1 through 3.
3.1.2 Specify the type of criteria that are to be maximized or minimized.			N/A	The Functional Objective (FO) for the Nuclear Emulsion (S-009) Experiment is. • FO-1 Install the Nuclear Emulsion detector package in the Multiple Docking Adapter (MDA), expose it to cosmic radiation, and return it to earth for investigation. Reference documents 1, 2, and 4.
3.1.3 Specify the percentage of acceptable max./min. for each objective.	60%	80% 100%	N/A	If Experiment S-009 operations are accomplished as scheduled, without compromise to experiment performance, then FO-1 is maximized at 100 percent. However, if the experiment's performance is compromised, then it should not be degraded below 60 percent minimum acceptable performance value. This value represents an arbitrary accomplishment of 0.60 of the Nuclear Emulsion experiment objective. Reference documents 1 and 2.

*Criticality Category Number Definition:

- Category I--Experiment and equipment whose failure could adversely affect crew safety.
- Category II--Experiment and equipment whose failure could result in not achieving a primary mission objective, but does not adversely affect crew safety.
- Category IIIa--Experiment and equipment whose failure could result in not achieving a secondary mission objective, but which does not adversely affect crew safety or preclude the achievement of any primary mission objective.
- Category IIIb--Experiment and equipment whose failure could not result in a loss of primary or secondary mission objective and does not adversely affect crew safety.

TABLE K-1. EXPERIMENT S-009, NUCLEAR EMULSION PRE-FLIGHT OPERATION EVALUATION ANALYSIS (Sheet 2 of 14)

FUNCTIONAL BLOCK NUMBER AND TITLE	EXPECTED RANGE AND DIMENSION OF VARIABLES		CRITICALITY CATEGORY NUMBER	REMARKS
	MIN.	NOM. MAX.		
3.1.4 Specify experiment constraints: <ul style="list-style-type: none"> • Musts • Must Not • Wants • Don't Wants 			N/A	<ul style="list-style-type: none"> • Musts <ul style="list-style-type: none"> --The detector package will be stowed in the Orbital Workshop (OWS) film vault prior to exposure and will be closed, secured, and stowed in the Command Module (CM) prior to reentry. --The detector package will be placed in the experiment housing in the MDA within 5 days after launch, and remain there throughout SL-2 flight operations. Reference document 6 indicates that the detector package can be deployed as early as 3 days, and will probably be the control document insofar as Experiment S-009 is concerned. --The detector package must be closed (data rejection mode) whenever the Orbital Assembly (OA) is north of the 30° N LAT line or S of the 25° S LAT line. This is accomplished automatically four times for an orbit --The experiment's line of sight Field of View (FOV) is 22° and will point at space perpendicular to the OA X axis. The β angle changes throughout the mission; the astronaut will be required to manually align the detector package to maintain the viewing axis perpendicular to the orbit plane. The frequency of this operation will vary from approximately 1 adjustment per day to 1 adjustment every 6 days, depending on what part of the β angle versus time curve the mission covers. --The detector package is completely passive and requires no active thermal control. Its equilibrium temperature must agree with the values imposed on the MDA, from 60 to 90° F, although heat pulses up to 105° F can be tolerated for a 1 min period. The detector package must not exceed a minimum temperature requirement of 35° F. --A program schedule will be communicated from ground to the OA, after launch. The schedule will provide experiment initiation time and proper angular orientation of the S-009 detector package --The detector package must be recovered and placed under refrigeration (35 to 50° F) as soon as possible after reentry. --The detector package must be hand carried directly to the Principal Investigator (PI) within 5 days after recovery. • Must Not <ul style="list-style-type: none"> --The FOV ascribed to the detector must not be directed toward the earth or its atmosphere. It is not necessary to make any adjustments during earth pointing attitude orientation if the Z-LV(E) durations are fractions of orbits. • Wants <ul style="list-style-type: none"> --If the detector package is punctured during post mission recovery operations, it should be placed inside a humidity controlled container to protect the emulsion material.

S&E-ASTN-OT(6-71)

TABLE K-1. EXPERIMENT S-009, NUCLEAR EMULSION PRE-FLIGHT OPERATION EVALUATION ANALYSIS (Sheet 3 of 14)

FUNCTIONAL BLOCK NUMBER AND TITLE	EXPECTED RANGE AND DIMENSION OF VARIABLES		CRITICALITY CATEGORY NUMBER	REMARKS
	MIN.	NOM. MAX.		
3.1.4 (Concluded)				<ul style="list-style-type: none"> • Don't Wants --N/A
3.1.5 Specify experiment operational tolerances: <ul style="list-style-type: none"> • Musts • Must Nets • Wants • Don't Wants. 			N/A	Reference documents 1, 2, and 5. Refer to functional item 3.1.4.
3.2 Define decision rules and success criteria for experiment objectives.	20 days	21.7 days	N/A	If the experiment is aborted, then the probability of success (P_g) is equal to 0.0. If the experiment is compromised and minimum information is salvaged, $P_g = 0.1 - 0.5$; if maximum information is salvaged, $P_g = 0.5 - 0.9$. If the experiment is completed as scheduled $P_g = 1.0$. The detector package shall be exposed for a nominal time period of 527 hr (≈ 21.7 days) during the SL-2 flight. This calculation is based on the assumption that the experiment will be started on mission day 3, orbital revolution 46, 20:30 GMT. The experiment is expected to terminate on mission day 26, orbital revolution 377, 20:30 GMT. Reference document 5.
3.3 Specify experiment priority (numerical statement) for a given Skylab flight designation.			N/A	The Nuclear Emulsion FO-1 will be scheduled for flight on SL-1/SL-2. The flight scheduling precedence (priority) number is expected to be 220 for the S-009 experiment. The priority value indicates the relative importance of the experiment as related to the Skylab SL-1/SL-2 mission flight. The priority value is subject to change. Reference documents 6 and 30.
3.4 List and briefly describe the major subsystems for Experiment S-009.			N/A	Refer to functional items 3.4.1 and 3.4.2.
3.4.1 Describe the major functions.			N/A	The Nuclear Emulsion package is composed of three major subassemblies <ul style="list-style-type: none"> • An experiment housing is mounted on the support structure and serves as a holder

S&E-ASTN-OT(6-71)

TABLE K-1. EXPERIMENT S-009, NUCLEAR EMULSION PRE-FLIGHT OPERATION EVALUATION ANALYSIS (Sheet 4 of 14)

FUNCTIONAL BLOCK NUMBER AND TITLE	EXPECTED RANGE AND DIMENSION OF VARIABLES		CRITICALITY CATEGORY NUMBER	REMARKS
	MIN.	NOM. MAX.		
3.4.1 (Concluded)				<p>and rotating mechanism for this detector package. The housing and package can be rotated up to $\pm 73.5^\circ$, in increments of 7.5°, to compensate for changes in the β angle. The PERIOD ADJUST rheostat, POWER ON/OFF and INITIATE/RESET switches, and the stepping motor are located on the housing. The gear train, bib screws, limit switches, and other electronics are located internal to the housing.</p> <ul style="list-style-type: none"> A support structure frame is fabricated from aluminum and hand mounted to the MDA. It secures the experiment housing. The β angle adjust knob is located on the bottom of the framework and rotates the experiment housing about an axis parallel to the MDA X axis. The support structure will be locked in launch position (β angle is 0°) with a slide clip fastener. The detector package contains silver halide crystal emulsion sheets and polycarbonate resin separators stacked side by side, and bound by teflon and aluminized tape. Two emulsion stacks are secured in an aluminum package assembly that is hinged on one end which permits the emulsion to be exposed when open, and shielded when closed. There are four roller guide bearings (two at each end of the package) which are sized to slip into the guide slots of the experiment housing when the package is open. The hinge adjustment has roller bearings on each end and fits into the experiment housing carrier bib screw riders, and latches in place. The detector package has two manually operated spring loaded latches that retain it in the closed position for OWS film vault storage. <p>An electronics subassembly is part of the experiment housing. The electronics portion consists of a programmer, dc converter, clock pulse generator, stepping motor driver, relays, and switches. Three important electrical components that control the electronics are.</p> <ul style="list-style-type: none"> The Power ON/OFF switch supplies power to the stepping motor and eventually the timing circuit. The stepping motor drives a gear train which rotates a set of bib screws that in turn force the roller bearings to track within guide slots, and thereby open and close the detector package. The PERIOD ADJUST rheostat is used to vary the time rate of the clock pulse generator to adjust for orbital period irregularities. The rheostat setting is determined by the PI. The INITIATE/RESET switch controls the opening and closing of the detector package. The INITIATE position opens and the RESET position closes the detector package. The RESET position also resets the clock to zero when accumulative orbital period errors require a new PERIOD ADJUST rheostat setting. <p>Reference documents 1 through 4</p>

S&E-ASTN-OT(6-71)

TABLE K-1. EXPERIMENT S-009, NUCLEAR EMULSION PRE-FLIGHT OPERATION EVALUATION ANALYSIS (Sheet 5 of 14)

FUNCTIONAL BLOCK NUMBER AND TITLE	EXPECTED RANGE AND DIMENSION OF VARIABLES		CRITICALITY CATEGORY NUMBER	REMARKS
	MIN.	NOM. MAX.		
3.4.2 List major components.			N/A	The major subsystem components are: <ul style="list-style-type: none"> • Experiment Housing • Support Structure Frame • Detector Package. Reference documents 1, 3, and 4.
3.5 Define the S-009 experiment/carrier subsystem interfaces:			N/A	A set of Functional Block Diagrams (FBD) is submitted as Figure K-1 and is used as a subsystem component listing. Only critical subsystem components are identified and evaluated for failure, and are correlated to possible experiment/carrier interface problems. Reference documents 1 and 3.
<ul style="list-style-type: none"> • Physical <ul style="list-style-type: none"> --Mechanical --Electrical --Communications and Data --Support • Environmental <ul style="list-style-type: none"> --Natural and Induced --Contamination • Operational <ul style="list-style-type: none"> --Pointing and Control --Crew Safety --Sequence --Operability. 				
3.5.1 Support Structure			N/A	Refer to functional item 3.5.1.1.
3.5.1.1 Experiment Housing			N/A	Refer to functional item 3.5.1.1.1
3.5.1.1.1 Carrier Assembly			N/A	Refer to functional item 3.5.1.1.1.1.1
3.5.1.1.1.1.1 Determine the total probability of failure (P _T) for the detector package gates.	nil	0.2	IIIb	Two detector package gates are permanently hinged to the side of the carrier frame sub-assembly and retain the detector package in the experiment housing. Two sliding gate latches secure a detector package gate by clipping onto stud pins.

S&E-ASTN-OI(6-71)

TABLE K-1. EXPERIMENT S-009, NUCLEAR EMULSION PRE-FLIGHT OPERATION EVALUATION ANALYSIS (Sheet 6 of 14)

FUNCTIONAL BLOCK NUMBER AND TITLE	EXPECTED RANGE AND DIMENSION OF VARIABLES		CRITICALITY CATEGORY NUMBER	REMARKS
	MIN.	NOM. MAX.		
3.5.1.1.1.1 (Concluded)				<p>The probability of detector package gate failure is considered remote. It is estimated that the probability of detector package gate failure is nil, if all the gate latches are secured. If one gate latch is unsecured, it is subjectively estimated that the probability of detector package gate failure is 0.2. If the gates should fail, the following situation could occur:</p> <ul style="list-style-type: none"> • Mechanical <ul style="list-style-type: none"> --If the gates failed or were inadvertently left unsecured, the detector package roller bearings could not track properly and would eventually become jammed out of alignment. <p>The following indications can be used to determine the failure of the detector package gates:</p> <ul style="list-style-type: none"> • The clip pins do not engage into stud slots • The detector package gate is separated from face of carrier frame assembly • The roller bearings are not properly engaged on detector package gate rider surfaces. <p>Reference documents 1, 7, and 8.</p>
3.5.1.1.1.2 Determine the P_f for the drive train gearing.	nil	0.1	IIIb	<p>The drive train gearing is located internal to the carrier frame subassembly experiment housing, and provides the necessary mechanical advantage to open and close the detector package. The gears are fabricated from polycarbonate and steel material. They are alternately assembled so that a polymer gear meshes with a metal gear. A 28 Vdc stepping motor drives the gear train. The drive train gearing is susceptible to jamming of gears due to foreign matter. Small particles, chips, or other debris that might find their way into the gear case (during component assembly) could cause the gears to jam.</p> <p>The probability of detector package gate failure is considered remote. It is estimated that a 0.1 chance of failure could occur if proper cleanliness precautions are not followed. If the drive train gearing should fail, the following situation could occur:</p> <ul style="list-style-type: none"> • Mechanical <ul style="list-style-type: none"> --The detector package could not be opened or closed during experiment stepping motor operation. The drive train gearing cannot be operated in either forward or reverse direction. • Communications and Data <ul style="list-style-type: none"> --If the drive train gearing failed so that the detector package were exposed when it entered 30°N LAT and 25°S LAT earth orbital positions, the nuclear emulsion would be degraded, or possibly radiation damaged beyond usefulness.

S&E-ASTN-OT(6-71)

TABLE K-1. EXPERIMENT S-009, NUCLEAR EMULSION PRE-FLIGHT OPERATION EVALUATION ANALYSIS (Sheet 7 of 14)

FUNCTIONAL BLOCK NUMBER AND TITLE	EXPECTED RANGE AND DIMENSION OF VARIABLES		CRITICALITY CATEGORY NUMBER	REMARKS
	MIN.	NOM. MAX.		
3.5.1.1.1.2 (Concluded)				<p>The following indications can be used to determine the failure of the drive train gearing:</p> <ul style="list-style-type: none"> • The detector package is not closed (rejection mode) • Operation of the INITIATE/RESET switch will not open and/or close the detector package • Operation of the INITIATE/RESET switch causes the gear train to chatter, but no evidence of the detector package moving. <p>Reference documents 8 through 10.</p>
3.5.1.1.1.2.1.1 Determine the P_{ft} for the drive train bearings.	nil		IIIb	<p>The drive train bearings are mounted to gear box subassembly. The bearings are roller type and require lubrication using Esso Beacon 325 grease (MIL-G-3278A). These bearings accept the thrust loading of the drive train gearing and permit the stepping motor to convert its electrical advantage to mechanical advantage at minimum frictional loss</p> <p>The probability of failure for the bearings is considered extremely remote. If the bearing should fail, the following situation could be noted:</p> <ul style="list-style-type: none"> • Mechanical -- The drive train gearing would seize due to bearing/gear shaft failure. <p>The following indications can be used to determine the failure of the drive train bearings:</p> <ul style="list-style-type: none"> • The detector package cannot be opened or closed when the INITIATE/RESET switch is operated. • The stepping motor will not operate because of excessive bearing loading/drag. <p>Reference documents 9 and 11 through 14.</p>
3.5.1.1.1.2.2 Determine the P_{ft} for the bib screw.	nil		IIIb	<p>Two bib screws mechanically drive the detector package open and closed. The bib screws are enclosed by a yoke and bearing plate subassembly structure and are driven by the stepping motor through a gear train. The aft ends of the bib screws are supported by the gear box structure with a steel spur gear secured onto their shafts. The forward end is secured to a roll bearing that is housed by the bearing plate structure. The bib screws are lubricated with a trace amount of Esso Beacon 325 grease (MIL-G-3278A).</p> <p>The probability of failure for the bib screws is considered extremely remote. If the bib screws should fail, the following situations could occur:</p>

S&E-ASTN-OT(6-71)

TABLE K-1. EXPERIMENT S-009, NUCLEAR EMULSION PRE-FLIGHT OPERATION EVALUATION ANALYSIS (Sheet 8 of 14)

FUNCTIONAL BLOCK NUMBER AND TITLE	EXPECTED RANGE AND DIMENSION OF VARIABLES			CRITICALITY CATEGORY NUMBER	REMARKS
	MIN.	NOM.	MAX.		
3.5.1.1.1.2.2 (Concluded)					<ul style="list-style-type: none"> Mechanical <ul style="list-style-type: none"> --If the gear box subassembly bearing or a bearing block fails, it is possible for one bib screw to drag due to bearing binding and galling. There is not enough torque transmitted from the stepping motor to cause bib screw fracture. Sequence <ul style="list-style-type: none"> --Excessive bearing drag on a bib screw or superficial damage to a screw could cause the detector package to open or close more slowly than desired and thereby cause the clock pulse generator time synchronization to lead the actual functional operation of the detector package. <p>The following indications can be used to determine the failure of the bib screws:</p> <ul style="list-style-type: none"> The detector package cannot be opened or closed when operating the stepping motor, due to a seized bearing or jammed bib screw. The detector package does not open and close within clock pulse generator time synchronization allotments. Opening and closing of the detector package will not be synchronized with the orbital position of the OA. <p>Reference documents 7 through 10 and 15 through 17.</p>
3.5.1.1.1.2.3 Determine the P_{ft} for the latch bearing blocks	nil			IIIb	<p>A bearing block subassembly is attached to each bib screw using ball bearings. The block translates the rotational motion of the bib screw into linear displacement, and thereby becomes the actuation mechanism for opening and closing the detector package. The bearing block sub-assemblies interface with the detector package pivotal bearings and are secured by mechanical latches. The ball bearings are lubricated with a trace amount of Esso Beacon 325 grease (MIL-G-3278A).</p> <p>The probability of failure for the latch bearing blocks is considered extremely remote. If the blocks should fail, the following situations could occur:</p> <ul style="list-style-type: none"> Mechanical <ul style="list-style-type: none"> --If the ball bearings fail to cycle about the bib screw when operated and if binding occurs, the detector package could open or close slower than intended, or fail to operate altogether Sequence <ul style="list-style-type: none"> --Excessive latch block bearing drag could be transferred to the bib screw, and can eventually cause the detector package to open or close more slowly than desired, thereby causing the clock pulse generator time synchronization to lead the actual functional operation of the detector package.

TABLE K-1. EXPERIMENT S-009, NUCLEAR EMULSION PRE-FLIGHT OPERATION EVALUATION ANALYSIS (Sheet 9 of 14)

FUNCTIONAL BLOCK NUMBER AND TITLE	EXPECTED RANGE AND DIMENSION OF VARIABLES		CRITICALITY CATEGORY NUMBER	REMARKS
	MIN.	NOM. MAX.		
3.5.1.1.1.2.3 (Concluded)				<p>The following indications can be used to determine the failure of the latch bearing blocks:</p> <ul style="list-style-type: none"> ● Refer to functional item 3.5.1.1.1.2.2. Reference documents 15 through 17. <p>The guard screen assembly is attached to the carrier assembly at two hinge points and clipped in place by snapslide fasteners. The guard screen's function is to protect the emulsion stacks from foreign matter when the detector package is deployed open. If the screen is severely dented, it could become entangled in the detector package when it is deployed closed.</p> <p>The probability of failure for the carrier guard screen assembly is considered extremely remote. If screen assembly should fail, the following situation could occur:</p> <ul style="list-style-type: none"> ● Mechanical <ul style="list-style-type: none"> --The screen is severely dented or torn and interferes with the closing of the detector package. This situation could confound the PI's ability to discriminate between primary cosmic ray tracks and other energy particle tracks. <p>The following indications can be used to determine the failure of the screen assembly:</p> <ul style="list-style-type: none"> ● The detector package cannot be fully closed to the radiation rejection mode. ● The screen is entangled among the bib screw, latch, and latch spring, or the detector package pan and emulsion assemblies. <p>Reference documents 18 through 20.</p>
3.5.1.1.2.1 Determine the P_{ft} and net probability of failure (P_{fn}) for the limit switches (S3 through S6).	nil	$P_{ft} = 0.10$	IIIb	<p>Limit switches S5 and S6 are opened when the detector package is deployed open. When switches S5 and S6 are actuated closed, it means that the detector package is closed. Limit switches S3 and S4 are normally closed when the detector package is deployed open. When switches S3 and S4 are opened, it means that the detector package is deployed closed.</p> <p>The above limit switches are used to disconnect the power from the stepping motor that drives the detector package open and closed. It is expected that the limit switches will be adjusted so that the detector package open and close throw distance clearance is accurately set to avoid excessive bib screw, and gear drive train binding. The limit switches are designed to fail safe OPEN during a malfunction and thereby interrupt the 28 Vdc to the stepping motor.</p> <p>The probability of failure for the limit switches is considered remote. If the limit switches should fail, the following situations could occur:</p>

S&E-ASTN-OI(6-71)

TABLE K-1. EXPERIMENT S-009, NUCLEAR EMULSION PRE-FLIGHT OPERATION EVALUATION ANALYSIS (Sheet 10 of 14)

FUNCTIONAL BLOCK NUMBER AND TITLE	EXPECTED RANGE AND DIMENSION OF VARIABLES			CRITICALITY CATEGORY NUMBER	REMARKS
	MIN.	NOM.	MAX.		
3.5.1.1.2.1 (Concluded)		$P_{fn} = 0.05$			<ul style="list-style-type: none"> Mechanical <ul style="list-style-type: none"> --If the S3 and S4 limit switches detent power cutoff adjustments, on the latch bearing blocks, are not properly set, the bib screws could drive the bearing blocks into the forward wall of the gear housing assembly, and thereby cause the drive gear train to bind. --If the S5 and S6 limit switches detent power cutoff adjustments are not properly set, the bib screws could drive the detector package pan assembly into the limit switch brackets. Electrical <ul style="list-style-type: none"> --If the above mechanical situation occurred for limit switches S3 and S4, the limit switches will not open and power will still be provided to the stepping motor. Eventually the binding of the mechanical components will stall the stepping motor inoperative. The likelihood of this type of failure is considered remote due to the series redundancy circuit layout of the limit switches. --If the above mechanical situation occurred for limit switches S5 and S6, the limit switches will not open and power will still be provided to the stepping motor. The jamming of the detector package pan into the brackets, and consequently the binding of mechanical components will cause the stepping motor to stall inoperative. The likelihood of this situation occurring is considered remote. <p>The following indications can be used to determine the failure of the limit switches.</p> <ul style="list-style-type: none"> Clearance between all limit switch detents are excessive This can be determined by pressing a small common screwdriver against the detent guard and listening for an audible click, or noting the motion of the detector package. Superficial scratches or dents are apparent on the latch block or detector package pan. Stepping motor shock absorber may be slipping, causing stall condition. An audible clicking noise may or may not be heard, or a thumping vibration may be sensed if the astronaut places his hand on the stepping motor. <p>Reference documents 7 through 9 and 21 through 23.</p> <p>The stepping motor drives the detector package open and close on command from the INITIATE/ RESEI switch or through the programmer electronics subassembly.</p> <p>Discussion with NRL personnel reveals that the DMA 23516 stepping motor assembly, originally designated for flight use, will be retired and a newer model substituted. The new stepping motor will be an off-the-shelf item with packed bearings. The stepping motor part number is changed to DMA 23550, and has been approved by MSFC waiver for flight application.</p> <p>The power and voltage is supplied to the stepping motor from Airlock Module (AM) Bus No. 1. The motor is designed to operate on $28 \text{ Vdc} \pm 2\%$, with peak wattage expected to reach 22 W, while standby wattage should be 3 W. Nominal motor operation is expected to draw 11 W.</p>
3.5.1.1.2.2 Determine the P_{ft} for the stepping motor.	nl		0.02	IIIb	
	24 Vdc 3 W	28 Vdc 11 W	30 Vdc 22 W		

S&E-ASTN-OT(6-71)

TABLE K-1. EXPERIMENT S-009, NUCLEAR EMULSION PRE-FLIGHT OPERATION EVALUATION ANALYSIS (Sheet 11 of 14)

FUNCTIONAL BLOCK NUMBER AND TITLE	EXPECTED RANGE AND DIMENSION OF VARIABLES		CRITICALITY CATEGORY NUMBER	REMARKS
	MIN.	NOM. MAX.		
3.5.1.1.2.2 (Concluded)				<p>The probability of failure for the stepping motor is considered small. If the stepping motor should fail, the following situations could occur:</p> <ul style="list-style-type: none"> • Electrical --If the stepping motor fails to operate, the detector package could not be automatically of electrically opened or closed in support of the mission. The design of the stepping motor is such that if stalled, it will not burn up. <p>The following indications can be used to determine the failure of the stepping motor:</p> <ul style="list-style-type: none"> • Recycling of the INITIATE/RESET switch while the POWER switch is ON does not open or close the detector package. <p>Reference documents 8, 9, 14, and 23 through 25.</p>
3.5.1.1.2.6.1 -Determine the P_{ft} for the power switch.	nil		IIIb	<p>The POWER switch supplies power to the entire experiment. The stepping motor drives the detector package open and closed. Initiation of the POWER switch ON will start the clock pulse generator and programmer time synchronization sequence. If the POWER switch is actuated OFF, the clock pulse generator will be automatically reset to zero and the programmer sequence will be interrupted at some indeterminate point; as a result, the programmer sequence of operation can be interrupted in such a way that the detector package will not open or close in accordance with prearranged instructions. The INITIATE/RESET switch is designed to reset the programmer sequence to zero count in either INITIATE or RESET position; however, power must be supplied to the experiment (POWER switch - ON).</p> <p>The probability of failure for the POWER switch is considered extremely remote. If the POWER switch should fail, the following situations could occur:</p> <ul style="list-style-type: none"> • Electrical --The operation of the electronic components is precluded. • Sequence --Before actuating the POWER switch OFF, the detector package should be configured in the data rejection mode (close the detector package by actuating the INITIATE/RESET switch to the RESET position). Otherwise, the orbital period time synchronization sequence logic of the programmer will be out of phase with the detector package data gathering and data rejection modes.

S&E-ASTN-OT(6-71)

TABLE K-1. EXPERIMENT S-009, NUCLEAR EMULSION PRE-FLIGHT OPERATION EVALUATION ANALYSIS (Sheet 12 of 14)

FUNCTIONAL BLOCK NUMBER AND TITLE	EXPECTED RANGE AND DIMENSION OF VARIABLES		CRITICALITY CATEGORY NUMBER	REMARKS
	MIN.	NOM. MAX.		
3.5.1.1.2.6.1 (Concluded)				<p>The following indications can be used to determine the failure of the POWER switch</p> <ul style="list-style-type: none"> • The detector package cannot be opened or closed automatically. • The detector package cannot be opened or closed using the INITIATE/RESET switch when the POWER switch is ON. <p>Reference documents 3, 8, 22, 23, and 26.</p>
3.5.1.1.2.7.2 Determine the P_{ft} for the programmer.		0.05	IIIb	<p>The dc converter power supply is provided filtered 28 Vdc ± 4 from AM Bus No. 1. The output voltage is 5 Vdc, and is provided to the programmer binary counter circuitry and clock pulse generator amplifier.</p> <p>Twenty-eight Vdc, nominal, is provided to the following components and subassemblies:</p> <ul style="list-style-type: none"> • Limit switches, S3 through S6 • Circuitry filters, F1 and F2 • Power transfer relay K2 (maglatch) • Stepping motor, M1 • Control panel power switch, S1 • Clock pulse generator amplifier, M4 • Control panel INITIATE/RESET switch, S2 • Control panel PERIOD ADJUST potentiometer, R1 • Clock pulse generator, A1 • Stepping motor driver, A2 • Circuit breaker, AM/STS Panel No. 202.

S&E-ASTN-OT(6-71)

TABLE K-1. EXPERIMENT S-009, NUCLEAR EMULSION PRE-FLIGHT OPERATION EVALUATION ANALYSIS (Sheet 13 of 14)

FUNCTIONAL BLOCK NUMBER AND TITLE	EXPECTED RANGE AND DIMENSION OF VARIABLES			CRITICALITY CATEGORY NUMBER	REMARKS															
	MIN.	NOM.	MAX.																	
3.5.1.1.2.2.2 (Concluded)					<p>When power is applied to the electronics assembly, the clock pulse generator and programmer immediately begin to operate. If detector package sequencing does not occur 19.1 ± 0.2 min after POWER switch ON initiation, the clock will automatically initiate operation and close the detector package if open. If power is interrupted at the circuit breaker for 10 μsec, the electronics logic will probably initiate detector package cycling (deploy opened or closed). The electronics components require 10 min of warmup time to ensure nominal operation.</p> <p>The probability of failure for the programmer and associated electronic subsystems is considered small. If the programmer should fail, the following situation could occur:</p> <ul style="list-style-type: none"> • Electrical <ul style="list-style-type: none"> --The 5 Vdc power signal could not be delivered to the clock pulse generator amplifier. Any interruption of the binary count of the programmer, due to noise or power anomaly, will cause the clock pulse generator time synchronization to lag. If the programmer fails, then the pulse clock generator becomes nonfunctional, and the detector package cannot be opened or closed automatically using the experiment's electronics. However, the INITIATE/RESET switch can be used to manually operate the detector package open/closed. <p>The following indications can be used to determine the failure of the programmer:</p> <ul style="list-style-type: none"> • The detector package will not open or close within the prescribed orbital time periods. The clock pulse generator time synchronization is in error or inoperative due to either a miscount or malfunction of the binary counters. Discrete orbital period time references can be correlated to the detector package mode: <table border="1" style="margin-left: 40px;"> <thead> <tr> <th>Detector Package (mode)</th> <th>Orbital Period (LAT)</th> <th>Time (min)</th> </tr> </thead> <tbody> <tr> <td>Open</td> <td>30° N to 30° N</td> <td>19.1 ± 0.2</td> </tr> <tr> <td>Close</td> <td>25° S to 25° S</td> <td>28.9 ± 0.2</td> </tr> <tr> <td>Open</td> <td>25° S to 30° N</td> <td>19.2 ± 0.2</td> </tr> <tr> <td>Close</td> <td>30° N to 30° N</td> <td>26.1 ± 0.2</td> </tr> </tbody> </table> <p>Reference documents 6 through 5, 7, 8, 22, 23, 26, and 27.</p>	Detector Package (mode)	Orbital Period (LAT)	Time (min)	Open	30° N to 30° N	19.1 ± 0.2	Close	25° S to 25° S	28.9 ± 0.2	Open	25° S to 30° N	19.2 ± 0.2	Close	30° N to 30° N	26.1 ± 0.2
Detector Package (mode)	Orbital Period (LAT)	Time (min)																		
Open	30° N to 30° N	19.1 ± 0.2																		
Close	25° S to 25° S	28.9 ± 0.2																		
Open	25° S to 30° N	19.2 ± 0.2																		
Close	30° N to 30° N	26.1 ± 0.2																		

S&E-ASTN-OI(6-71)

TABLE K-1. EXPERIMENT S-009, NUCLEAR EMULSION PRE-FLIGHT OPERATION EVALUATION ANALYSIS (Sheet 14 of 14)

FUNCTIONAL BLOCK NUMBER AND TITLE	EXPECTED RANGE AND DIMENSION OF VARIABLES		CRITICALITY CATEGORY NUMBER	REMARKS
	MIN.	NOM. MAX.		
3.5.1.3.1 Determine the P_{ft} for the detector package roller bearings.	0.02		IIIb	<p>The detector package roller bearings are used to guide and track the opening and closing of the pan assemblies which contain the film stacks. Three bearings are of the same size while the fourth is smaller. This was done so that the detector package could be installed into the support structure in a prescribed orientation. The bearings travel within a given slotted track, and can be jammed inoperative if one or both carrier assembly gates are left completely unsecured.</p> <p>The probability of failure for the roller bearings is considered small. If the bearings should fail, the following situations could occur:</p> <ul style="list-style-type: none"> • Mechanical <ul style="list-style-type: none"> --See functional item 3.5.1.1.1.1.1. <p>The following indications can be used to determine the failure of the roller bearings:</p> <ul style="list-style-type: none"> • See functional item 3.5.1.1.1.1.1. <p>Reference documents 1, 7, 8, 9, 19, and 20.</p> <p>There are two pivot latches, one attached to each side of the detector package, that secure the emulsion packs in a closed position. The latches are spring loaded to detent open and closed.</p> <p>The probability of failure for the latches is considered remote. If the latches should fail, the following situation could occur:</p> <ul style="list-style-type: none"> • Operability <ul style="list-style-type: none"> --If the latches are not fully detented to the open position when installing the detector package into the carrier frame assembly, they could become entangled in the screen assembly when the detector package is actuated closed. <p>The following indications can be used to determine the failure of the latches:</p> <ul style="list-style-type: none"> • See functional item 3.5.1.1.1.3. <p>Reference documents 1, 3, 7, 8, 9, 19, 20, 28, and 29.</p>
3.5.1.3.3 Determine the P_{ft} for the detector package latches.	0.03			

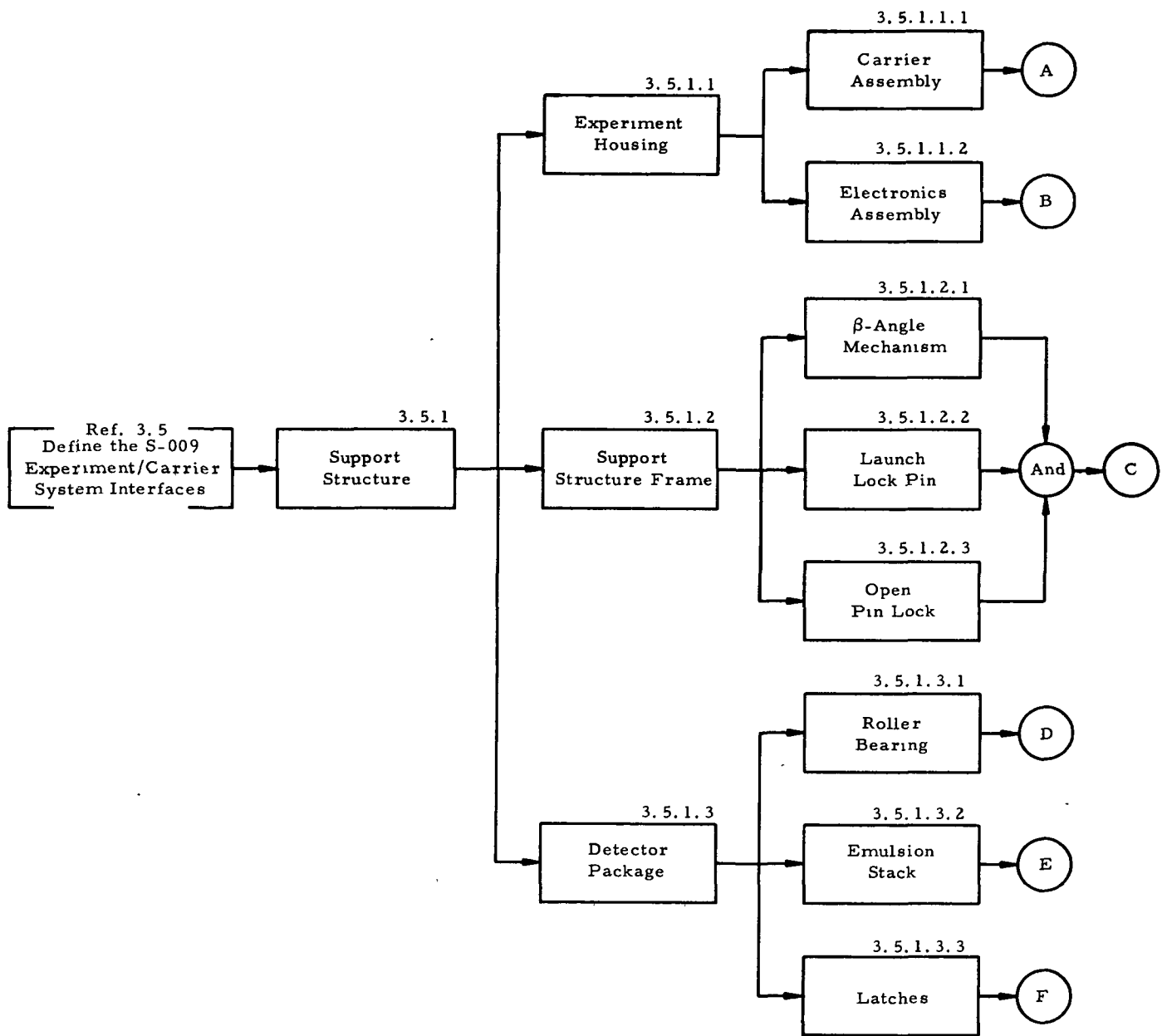

FIGURE K-1. EXPERIMENT S-009, NUCLEAR EMULSION FUNCTIONAL BLOCK DIAGRAM (Sheet 1 of 4)

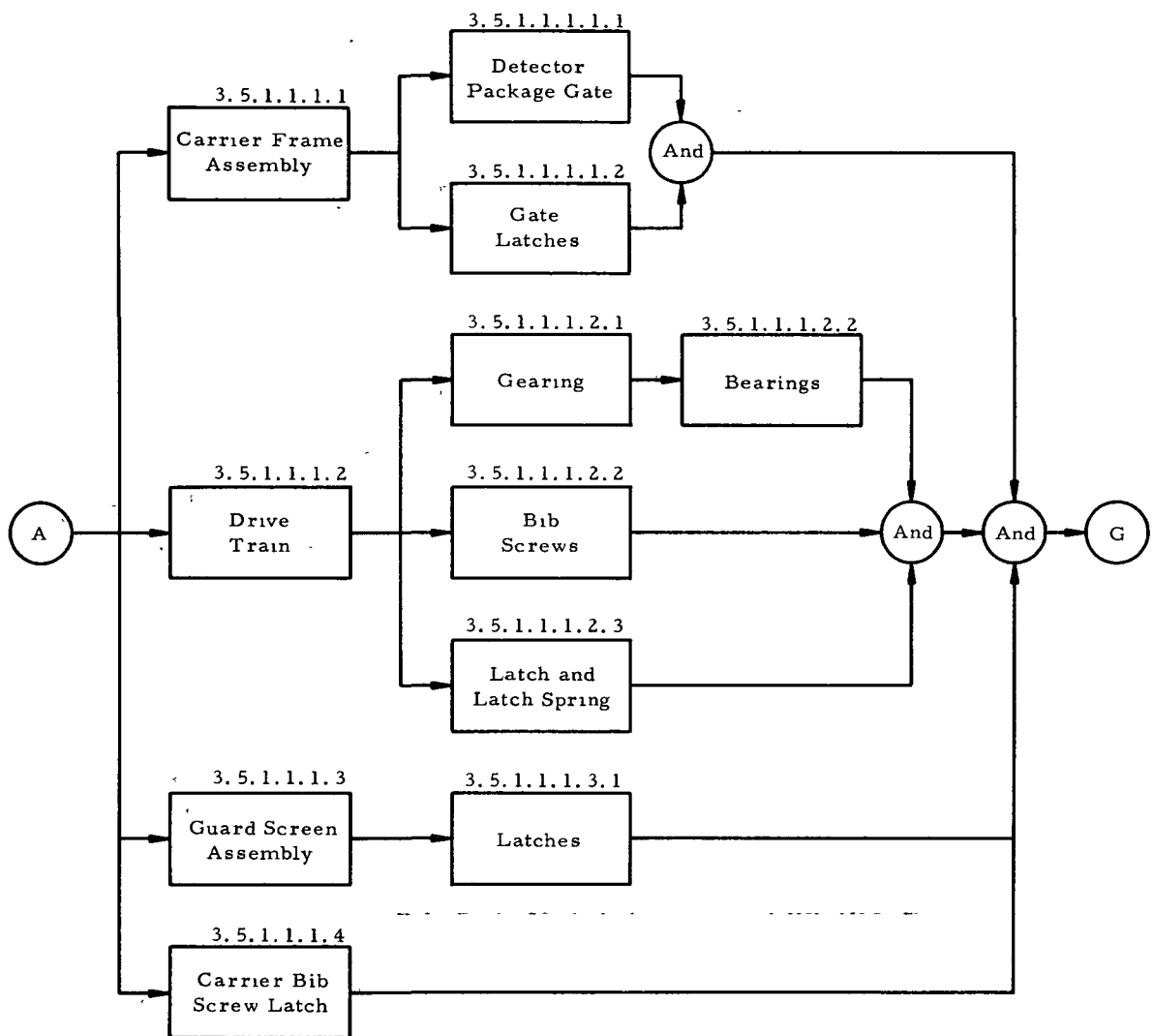

FIGURE K-1. EXPERIMENT S-009, NUCLEAR EMULSION FUNCTIONAL BLOCK DIAGRAM (Sheet 2 of 4)

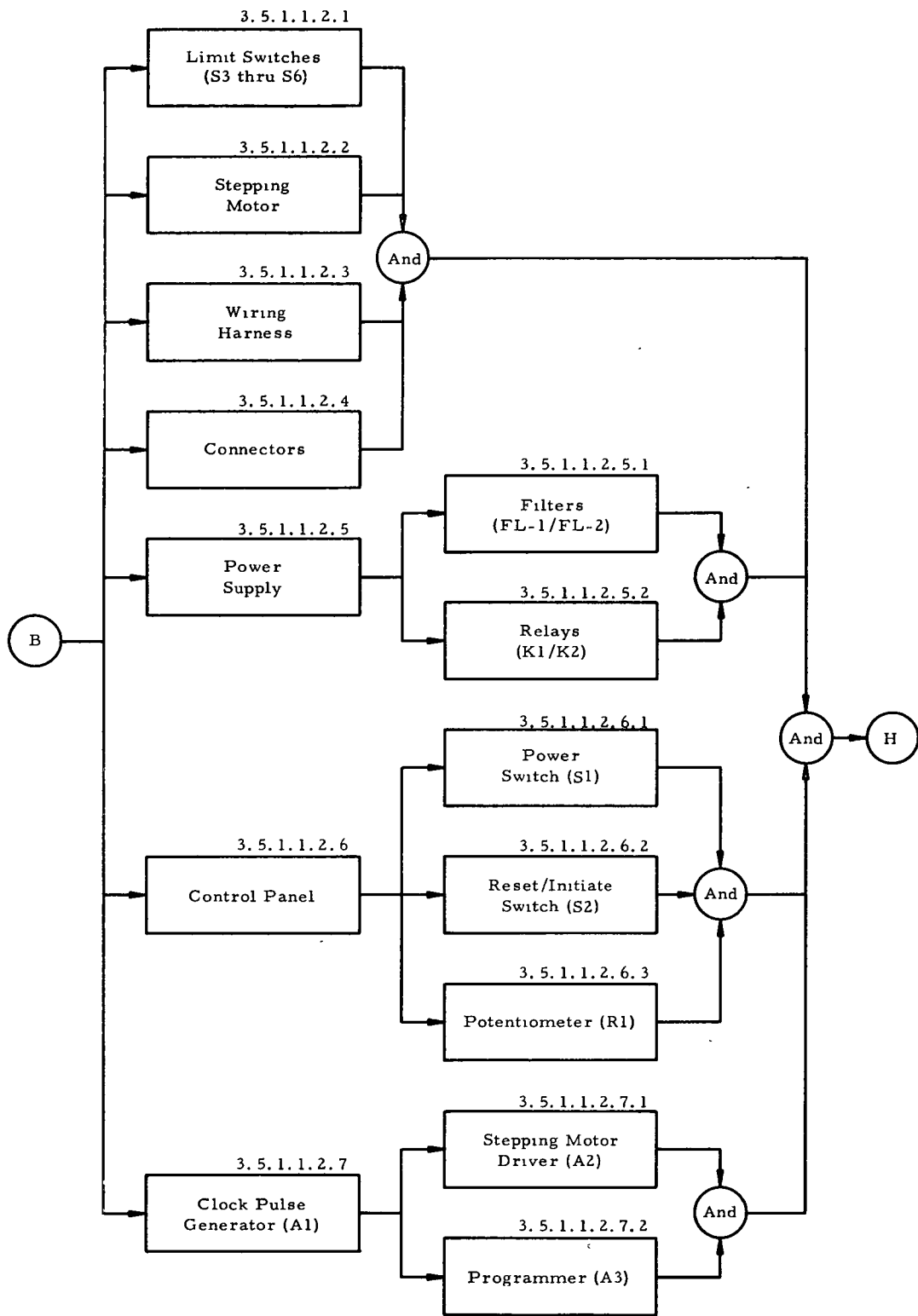

FIGURE K-1. EXPERIMENT S-009, NUCLEAR EMULSION FUNCTIONAL BLOCK DIAGRAM (Sheet 3 of 4)

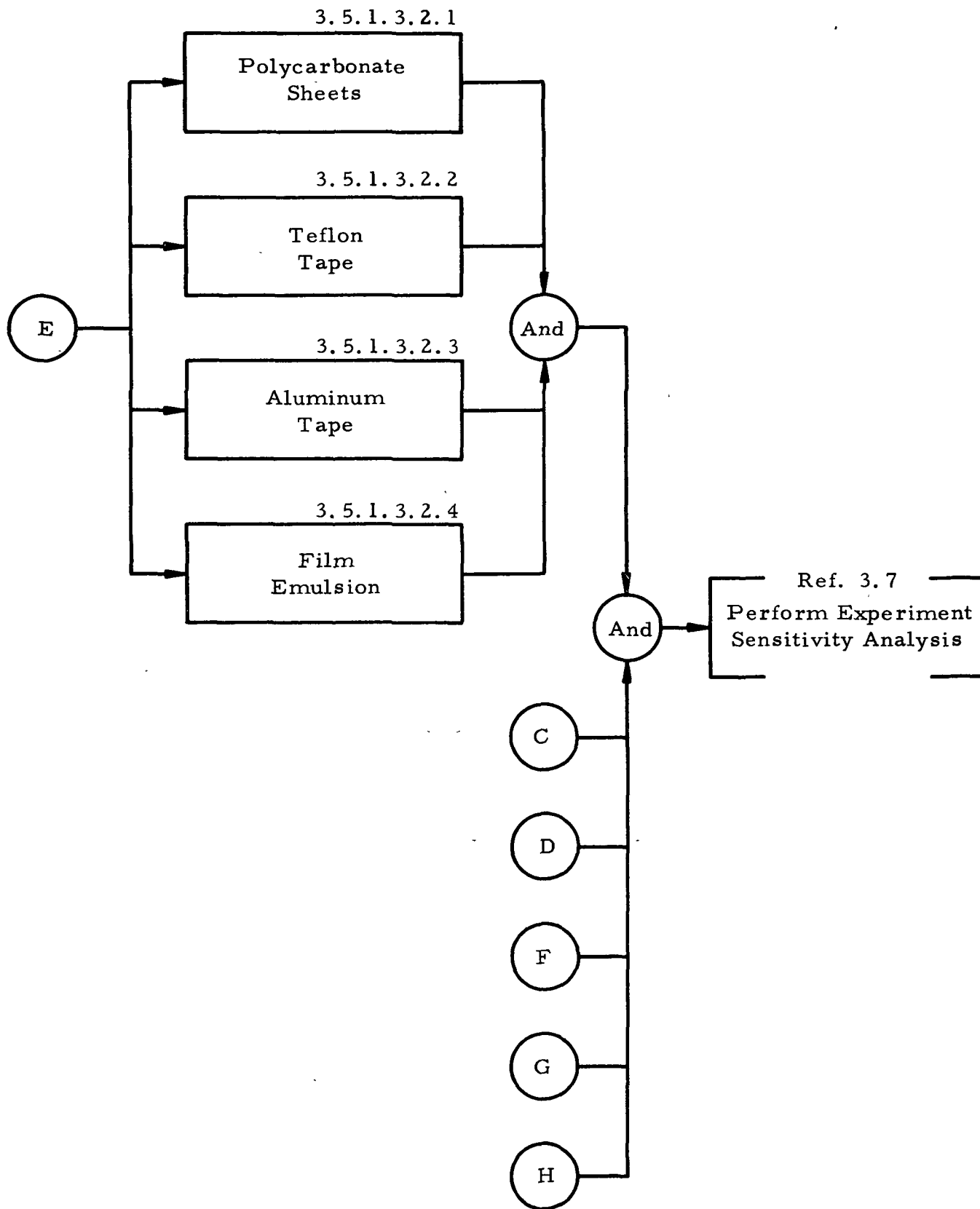
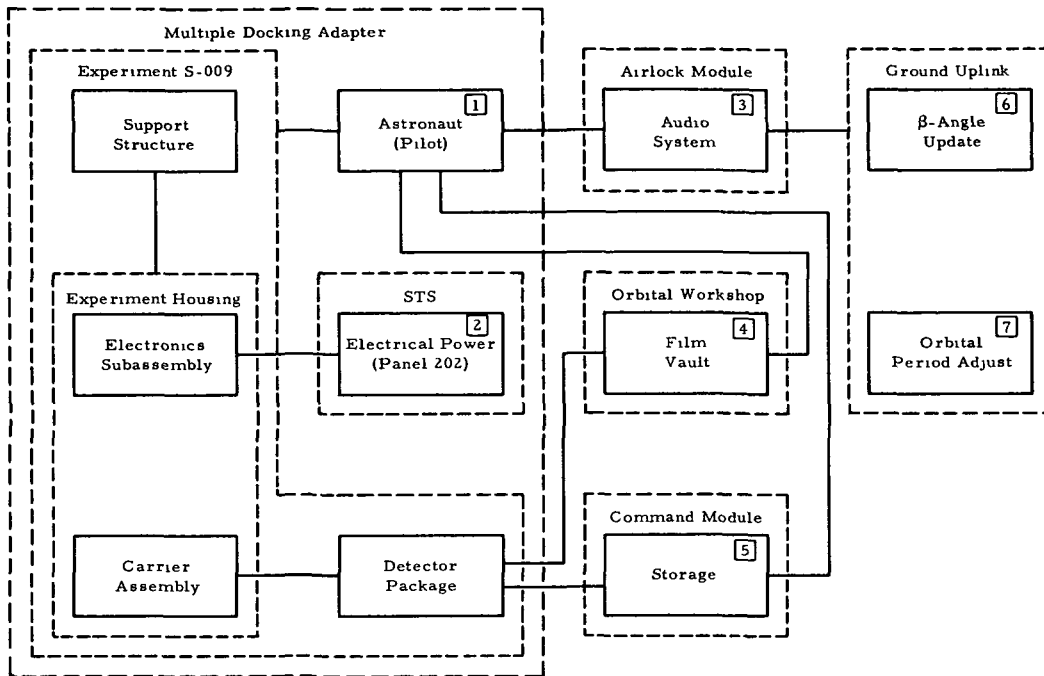
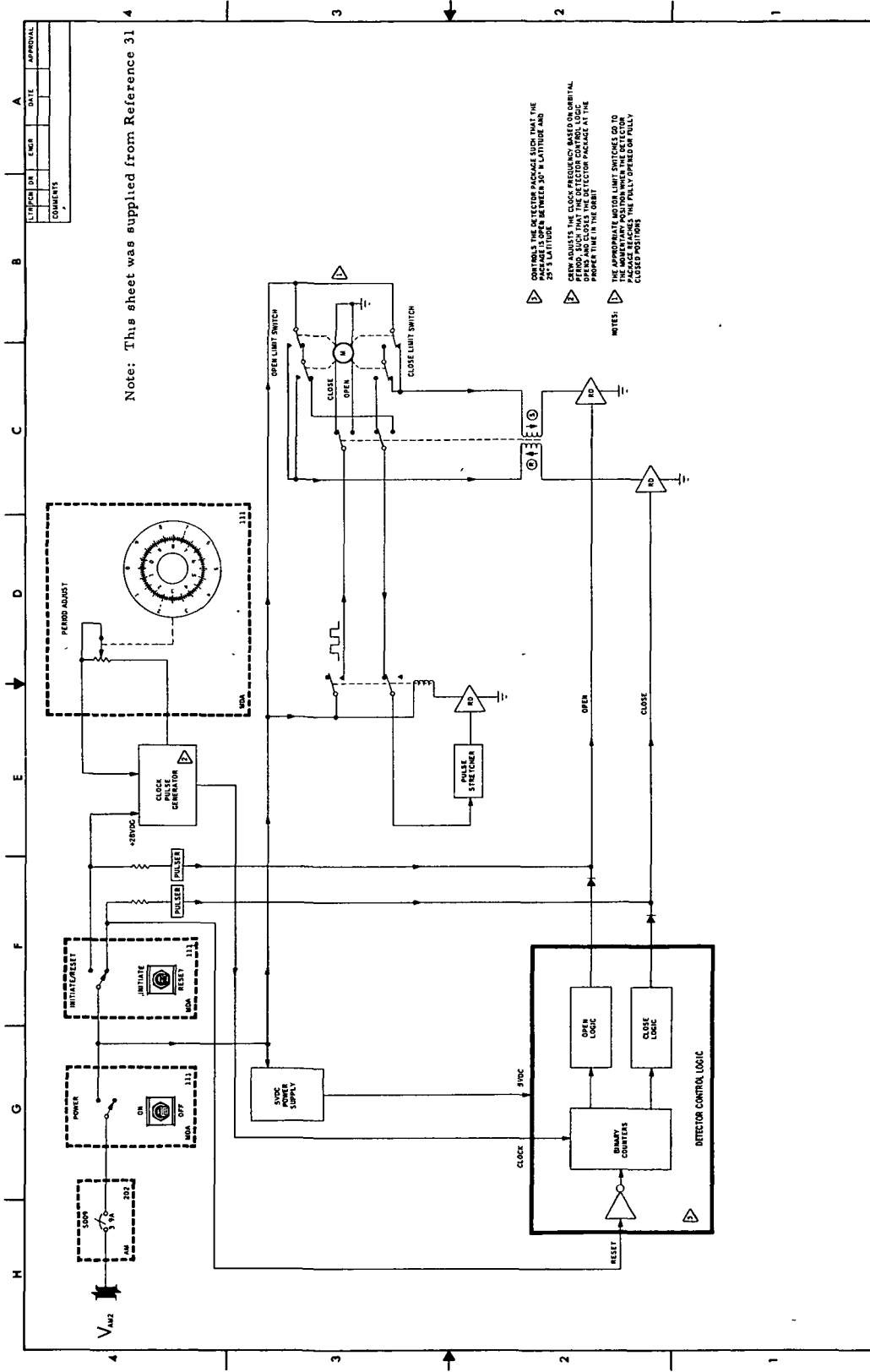

FIGURE K-1. EXPERIMENT S-009, NUCLEAR EMULSION FUNCTIONAL BLOCK DIAGRAM (Sheet 4 of 4)



Code	Data Source	Remarks
1	Crew	There are crew support and communications/data interfaces among the astronaut, Experiment S-009 major components, OWS film vault, CM detector package storage, AM audio system, and ground operations. The astronaut must handle the experiment's components, including the removal and installation of the detector package from the OWS film vault and CM storage. A communications data link is established between the PI on the ground and the astronaut in the OA.
2	M156-513	There is an electrical interface between the MDA/STS electrical power supply and the S-009 Electronics Subassembly. Power is supplied to the electronics subassembly through the cb S-009 found on AM/STS panel 202. A POWER switch, located on the experiment housing, receives the input from panel 202, and functions as the control point for experiment operation. An INITIATE/RESET switch is placed in series with the POWER switch and automatically opens and closes the detector package during experiment operations.
3	Crew PI/Communicator	There is a communications and data interface among the astronaut, AM audio system, and the ground. The β angle update, and orbital period adjust data, generated by computer program, is uplinked once a day by the ground personnel to the astronaut through the AM audio system. The astronaut can verify any corrective settings through the audio system in contact with the ground.
4	C0039-807 C0005-807 C0018-807 C0019-807 C7044-436	There is a mechanical and environmental interface between the experiment's detector package and OWS film vault. The detector package is stored in the OWS film vault before launch, launched, and used during SL-1/SL-2 experiment operations as needed. The detector package film emulsion is susceptible to damage from high radiation, high and low temperature extremes, and high humidity condition. A crew support interface between the OWS film vault and the astronaut is explained in Code 1.
5	CF0002 C0039-807 C0005-807 C0018-807 C0019-807	There is a mechanical and environmental interface between the experiment's detector package and the CM storage bay. The detector package is stored in the CM after experiment completion for return to Earth. The environmental interfaces are explained in Code 4, and a crew support interface is explained in Code 1.
6	Crew	Refer to Code 3.
7	PI/Communicator	Refer to Code 3.

FIGURE K-2. EXPERIMENT S-009, NUCLEAR EMULSION INTERFACE BLOCK DIAGRAM AND DEFINITION



Note: This sheet was supplied from Reference 31

FIGURE K-3. EXPERIMENT S-009, NUCLEAR EMULSION SYSTEMS DIAGRAM

SECTION IV.
EXPERIMENT S-009, NUCLEAR EMULSION DATA
REQUIREMENTS SUMMARY

TABLE K-II. EXPERIMENT S-009, NUCLEAR EMULSION DATA REQUIREMENTS SUMMARY

Measurement Name	Range and Dimension of Variable	Measurement Number	Telemetry Assignment Channel	Data Return	Data Time	Remarks
<ul style="list-style-type: none"> ● Astronaut Voice Comments --Control Panel Potentiometer --β-Angle Input (Uplink) --On-Board Timing (GMT) ● Temp. Internal Fwd. Cyl. 6 ● Temp. Internal Fwd. Cyl. 2 ● Temp. Atmospheric Gas 1 ● Temp. Atmospheric Gas 2 ● Temp. TCS Fwd. Compt. No. 6 Transducer Assy ● OA Ephemeris Data ● V AM Bus No. 2 Voltage Condr. - Vdc Monitor ● Cabin Temperature (CM) ● On-Board Timing (GMT) ● OA Attitude ● Log Book 	<p>TBD ±73.5° N/A</p> <p>-5 to 45 °C -5 to 45 °C -5 to 45 °C -5 to 45 °C</p> <p>0 to 120 °F or -17.75 to 48.9 °C</p> <p>TBD</p> <p>24 to 30 Vdc</p> <p>TBD TBD</p> <p>TBD N/A</p>	<p>N/A N/A N/A</p> <p>C0039-807 C0005-807 C0018-807 C0019-807 C7044-436</p> <p>TBD</p> <p>M156-513 CF002 K502-512</p> <p>K382-702 N/A</p>	<p>N/A N/A N/A</p> <p>WP1A065A47LN19 WP1A140A84LP29 WP1A114A63LC23 WP1A104A72LB26 WP1B050A13LM03</p> <p>TBD</p> <p>WP1B044A11HB59</p> <p>TBD WP1A124A04D107 WP1A045A03D107 WP1A046A03D107 WP1A047A03D107</p> <p>TBD N/A</p>	<p>Intermittent Intermittent Intermittent</p> <p>Continuous Continuous Continuous Continuous Continuous</p> <p>Continuous</p> <p>Housekeeping Continuous Event</p> <p>Event N/A</p>	<p>Real Real Real</p> <p>All All All All All</p> <p>Real</p> <p>Real/All All Real</p> <p>Real N/A</p>	<p>Uplink Uplink Voice Verification</p> <p>OWS film storage</p> <p>At points intersecting the 30 °N and 25° S LAT</p> <p>TBD</p>

DATA REQUEST FORM Skylab Program		DRF Control No.		Date 9-22-71
		Exp/Sys No. ASTN-SDI/MDA/S-009		Revision 1
Mission SL-1/2	Period of Interest Flight/Experiment Manned		Op. Need Date	Rev Date 3-31-72
Request Contact		Data Recipient		Date Req All Time
Name E. Fleischman	Name W. Bock		Address MSFC, S&E-ASTN-SDF	Qty 1
Organization MSFC, PM-MO-I	Address MSFC, S&E-ASTN-SDF			
Phone 205-453-3657	Phone 205-453-3810			
Reference Document: ERD: SE-010-002-2H, 1-20-70; SFP: MSC-03625, 10-30-70				
MRD Content				
<p>Detailed Requirements:</p> <p>Voice transcripts of astronaut comments are needed from MSC for all S-009 experiment activities. The transcript should be made available to S&E-ASTN-SDI as soon as possible after experiment startup.</p> <p>One copy of the log book is requested as soon as possible after CM splashdown.</p>				
<p>Comments & Explanation:</p> <p>These data will be used to measure and evaluate the integrity of experiment/carrier interfaces so that the Skylab Mission Evaluation reporting requirements can be fulfilled (see OMSF Program Directive 35, M-D ML 3200.138, 5-71).</p>				
Originator			Integrator	
Name J. E. Meyers	Organization Teledyne Brown, ASD-SHI		Name	
Phone 205-532-1561	Signature		Organization	
Date	Date		Phone	
			Signature	Date
Request Approval			Implementing Agency	
Name	Organization		Name	
Organization	Phone		Organization	
Phone	Signature		Phone	
Signature	Date		Signature	Date

DATA REQUEST FORM Skylab Program		DRF Control No.	Date
		Exp/Sys No. ASTN-SDI/MDA-S-009	9-22-71
Mission SL-1/2	Period of Interest Flight/Experiment Manned	Op. Need Date	Revision 1
Request Contact		Data Recipient	Date Req Real Time
Name E. Fleischman	Organization MSFC, PM-MO-I	Name W. R. Bock	Qty 1
Phone 205-453-3657		Address MSFC, S&E-ASTN-SDF	
Reference Document: ERD; SE-010-002-2H, 1-20-70; SFP; MSC-03625, 10-30-70			
MRD Content			
Detailed Requirements: S&E-ASTN-SDI needs to verify the AM Bus No. 2 Voltage at the experiment/carrier interface. This voltage verification is needed 10 min before initializing the procedures for the performance of the S-009 experiment tasks. The voltage level is required again when the experiment is actually started (power ON and programmer operating). A GMT time correlation reference frame for experiment/system data is needed when S-009 is initialized "START". Voice update and confirmation is adequate. Astronaut voice loop comments of S-009 experiment operations are required when installing the detector package, changing the β angle, setting the PERIOD ADJUST rheostat, and operating the INITIATE/RESET switch.			
Comments & Explanation: These data will be used to measure and evaluate the integrity of experiment/carrier interfaces so that the Skylab Mission Evaluation reporting requirements can be fulfilled (see OMSF Program Directive 35, M-D ML 3200.138, 5-71).			
Originator		Integrator	
Name J. E. Meyers	Organization Teledyne Brown, ASD-SHI	Name	Date
Phone 205-532-1561	Signature	Organization	Signature
	Date	Phone	Date
Request Approval		Implementing Agency	
Name	Organization	Name	Organization
Phone	Signature	Phone	Signature
	Date		Date

DRF Control No.

Exp/Sys No.

ASTN-SDI/MDA/S-009

Revision

1

Date

3-31-72

Detailed Requirements:

<u>Measurement No.</u>	<u>Measurement Name</u>
M156-513 (Housekeeping)	V AM Bus No. 2 Voltage
K502-512	Onboard Timing (GMT)

Detailed Requirements: (Continued)

OA ephemeris and attitude data are needed to correlate the experiment detector package opening and closing with the 30° N and 25° S LAT positions, and the β angle.

All of the above data requests are dependent on MSFC/HOSC Skylab Flight Plan operational timeline updates. S&E-ASTN-SDI will monitor the HOSC operational timeline updates and will confirm or advise S&E-COMP-RRG as to specific data requests approximately 60 min before they are needed.

DATA REQUEST FORM Skylab Program		DRF Control No.		Date
		Exp/Sys No. ASTN-SDI/MDA/S-009		9-22-71
Mission	Period of Interest	Op. Need Date		Revision
SL-1/2	Flight/Experiment Manned			1
Request Contact		Data Recipient		Date Req
Name	E. Fleischman	Name	W. R. Bock	All Time
Organization	MSFC, PM-MO-I	Address	MSFC, S&E-ASTN-SDF	Qty
Phone	205-453-3657	Phone	205-453-3810	1
Reference Documents: ERD: SE-010-002-2H, 1-20-70; SFP: MSC-03625, 10-30-70				
MRD Content				
<p>Detailed Requirements:</p> <p>S&E-ASTN-SDI requires the capability to monitor and assess the level of AM Bus No. 2 Voltage for the S-009 experiment. The voltage levels are needed once every 24 hr for the duration of experiment operation. The voltage data may be provided as tabular autoscan printout.</p> <p>Four analog temperature measurements are needed to assess the status of the MDA internal cylinder environment, and should be recorded using an SC-4020 plotter. The cylinder temperature measurements are needed 4 times every 24 hr for the duration of experiment operations.</p> <p>The OWS film vault temperature is needed when the detector package is stored during L - 45 days and launch-through package deployment in the MDA.</p>				
<p>Comments & Explanation:</p> <p>These data will be used to measure and evaluate the integrity of experiment/carrier interfaces so that the Skylab Mission Evaluation reporting requirements can be fulfilled (see OMSF Program Directive 35, M-D ML 3200.138, 5-71).</p>				
Originator			Integrator	
Name J. E. Meyers			Name	
Organization Teledyne Brown, ASD-SHI			Organization	
Phone 205-532-1561			Phone	
Signature			Signature	
Request Approval			Implementing Agency	
Name			Name	
Organization			Organization	
Phone			Phone	
Signature			Signature	
			Date	

DRF Contract No.	Exp/Sys No. ASTN-SDI/MDA/S-009	Revision 1	Date 3-31-72
------------------	-----------------------------------	---------------	-----------------

Detailed Requirements:

M156-513 (Housekeeping)	V AM Bus No. 2 Voltage
C0039-807	Temp, Internal Fwd. Cyl. 6
C0005-807	Temp, Internal Fwd. Cyl. 2
C0018-807	Temp, Atmospheric Gas 1
C0019-807	Temp, Atmospheric Gas 2
C7044-436	Temp, OWS Film Vault (Compartment J1)
CF0002	Temp, Cabin (CM)

Detailed Requirements: (Continued)

The CM storage compartment temperature is required when returning Experiment S-009 to earth. These data may be provided in any manner that facilitates the reduction, handling, and reporting.

All of the above data requests are dependent on MSFC/HOSC Skylab Flight Plan operational timeline updates. S&E-ASTN-SDI will monitor the HOSC operational timeline updates and will confirm or advise S&E-COMP-RRG as to specific data requests approximately 60 min before they are needed.

One OWS analog temperature measurement is needed to assess the gross status of the film vault, and should be recorded digitally. The OWS temperature measurement is needed once every 24 hr during mission days 1 through 5.

One CM analog temperature measurement is needed to assess the temperature within the CM, and should be recorded using an SC-4020 plotter. The temperature measurement is needed from CM detector package storage to CM splashdown, with the majority of measurements occurring during entry and descent, and post landing phases.

DATA REQUEST FORM Skylab Program		DRF Control No.	Date
		Exp/Sys No. ASTN-SD/MDA/S009-019	Revision
Mission SL-1/2	Period of Interest Flt/Expt, Man	Op. Need Date	Rev Date
Request Contact		Data Recipient	
Name F. H. Butler	Name Mr. W. R. Bock	Address S&E-ASTN-SDF MSFC, Alabama 35812	Data Req Opns
Organization PM-MO-I	Phone 205-453-3657		Phone 205-453-3810

Reference Documents ERD: SE-010-002-2H, 1-20-70; SFP: MSC-03625, 10-30-70

MRD Content

Detailed Requirements: Experiment S009 Real-Time Voice Comments

Voice loop of astronaut comments are needed for initializing procedures, start-up, update, adjustment, and termination of the S009 experiment tasks; also, when installing the detector package, changing the beta angle, and setting the PERIOD ADJUST switch

Comments & Explanations:

Originator Name Mr. W. R. Bock Organization MSFC/S&E-ASTN-SDF Phone 205-453-3810 Signature _____ Date _____		Integrator Name J. R. Riquelmy Organization S&E-ASTN-SDF Phone 205-453-3810 Signature _____ Date _____	
Request Approval Name H. Golden Organization PM-MO-I Phone 205-453-3735 Signature _____ Date _____		Implementing Agency Name _____ Organization _____ Phone _____ Signature _____ Date _____	

DATA REQUEST FORM Skylab Program		DRF Control No.		Date
		Exp/Sys No. ASTN-SD/MDA/S009-020		Revision
Mission SL-1/2	Period of Interest		Op. Need Date	Rev Date
Request Contact		Data Recipient		Date Req HOSC + 72 hr
Name D. A. Schaefer	Name Mr. W. R. Bock		Qty 1	
Organization PM-MO-I	Address S&E-ASTN-SDF			
Phone 205-453-3659	Phone MSFC, Alabama 35812 205-453-3810			
Reference Document: ERD: SE-010-002-2H, 1-20-70; SFP: MSC-03625, 10-30-70				
MRD Content				
Detailed Requirements: Experiment S009 Voice Transcripts Voice transcripts of astronaut comments are required for all S009 experiment activities. The transcripts should be made available within 72 hours.				
Comments & Explanations:				
Originator		Integrator		
Name Mr. W. R. Bock	Name J. R. Riquelmy		Date	
Organization MSFC/S&E-ASTN-SDF	Organization S&E-ASTN-SDF		Date	
Phone 205-453-3810	Phone 205-453-3810		Date	
Signature	Date	Signature	Date	
Request Approval		Implementing Agency		
Name H. Golden	Name		Date	
Organization PM-MO-I	Organization		Date	
Phone 205-453-3735	Phone		Date	
Signature	Date	Signature	Date	

DATA REQUEST FORM Skylab Program		DRF Control No.	Date 09-22-71
		Exp/Sys No. ASTN-SD/MDA/S009-022	Revision
Mission S-1/2	Period of Interest Flt/Expt, Man	Op. Need Date	Rev Date
Request Contact		Data Recipient	
Name D. A. Schaefer	Name Mr. W. R. Bock	Date Recd HOSC + 24 hr	
Organization PM-MO-I	Address S&E-ASTN-SDF	Qty 1	
Phone 205-453-3659	Phone 205-453-3810		
Reference Document: ERD: SE-010-002-2H, 1-20-70; SFP: MSC-03625, 10-30-70			
MRD Content			
Detailed Requirements: Experiment S009 Film Storage Temperature The OWS film vault temperature (compartment J1) is needed when the detector package is stored during launch minus 45 days and launch through package deployment in the MDA.			
Comments & Explanations:			
Originator		Integrator	
Name Mr. W. R. Bock	Name J. R. Riquelmy	Date	
Organization MSFC/S&E-ASTN-SDF	Organization S&E-ASTN-SDF	Date	
Phone 205-453-3810	Phone 205-453-3810	Date	
Signature	Signature	Date	
Request Approval		Implementing Agency	
Name H. Golden	Name	Date	
Organization PM-MO-I	Organization	Date	
Phone 205-453-3735	Phone	Date	
Signature	Signature	Date	

DATA REQUEST FORM Skylab Program		DRF Control No.	Date 09-22-71
		Exp/Sys No. ASTN-SD/MDA/S009-023	Revision
Mission SL-1/2	Period of Interest Flt/Expt, Man		Op. Need Date
Request Contact		Data Recipient	
Name D. A. Schaefer	Name Mr. W. R. Bock		Date Req Post-Flt
Organization PM-MO-I	Address S&E-ASTN-SDF		Qty 1
Phone 205-453-3659	Phone MSFC, Alabama 35812 205-453-3810		
Reference Document: ERD: SE-010-002-2H, 1-20-70; SFP: MSC-03625, 10-30-70			
MRD Content			
Detailed Requirements: The CSM S009 detector package storage compartment temperature is required when returning the experiment to earth. The data may be provided in any manner that facilitates the reduction, handling, and reporting. The S009 detector package temperature should be monitored and verified during recovery and transportation to the principal investigator (PI). The data may be provided in any manner that facilitates the reduction, handling, and reporting.			
Comments & Explanations: 			
Originator Name Mr. W. R. Bock Organization MSFC/S&E-ASTN-SDF Phone 205-453-3810 Signature _____ Date _____		Integrator Name J. R. Riquelmy Organization S&E-ASTN-SDF Phone 205-453-3810 Signature _____ Date _____	
Request Approval Name H. Golden Organization PM-MO-I Phone 205-453-3735 Signature _____ Date _____		Implementing Agency Name _____ Organization _____ Phone _____ Signature _____ Date _____	

Engineering Change Requests for Experiment S-009 are N/A.

TABLE K-111. EXPERIMENT S-009, NUCLEAR EMULSION EVALUATION SEQUENCE (Sheet 1 of 14)

<u>Assignments</u>	<u>Conditions</u>	<u>Requirements</u>
Mission:		
• SL-1/SL-2	• The PLT prepares, operates, monitors, and terminates the experiment	• FO-1: Install the Nuclear Emulsion detector package in the MDA, expose it to cosmic radiation, and return it to earth for investigation
Orbital Assembly	Crew.	
• MDA	Experiment.	
--Support Structure	• Experiment operations commence when the OA passes over the 30 °N LAT going S.	
--Experiment Housing	• Detector package data gathering modes (package open) are orbital periods between 30 °N, and 25 °S LAT positions.	
• OWS	• Detector package data rejection modes (package closed) are those orbital periods above 30 °N and below 25 °S LAT	
--Detector Package	• Power is supplied to the experiment by AM Bus No. 2 at 28 ±2 Vdc.	
Carrier:	• Duration	
• The Experiment is operated inside the MDA, at OA Sta. No. TBD	--Preparation Phase: ~0.5 hr	
• The detector package is launched and stored in the OWS film vault, adjacent to Position IV, at OWS Sta. No. 2997.000.	--Operation Phase: ~51.5 hr	
• The detector package is stowed in the CM storage locker A5 after experiment termination, and returned to earth.	--Termination Phase: ~0.3 hr.	
	Ground Support:	
	• A computer program will be in operation and provide: --Orbital period adjust data --β-angle corrections	
	Experiment Evaluation Team--Key Personnel Locator	
Name	Responsibility	Office Address, Symbol, and Telephone Number
Dr. M. Shapiro	Principal Investigator (PI)	Naval Research Laboratory, Washington, D. C., 202-767-2747
Mr. R. Ford (Electrical)	Experiment Developer (ED)	Naval Research Laboratory, Washington, D. C., 202-767-2274
Mr. T. Beck (Mechanical)	Experiment Developer (ED)	Naval Research Laboratory, Washington, D. C., 202-767-2331
Mr. F. W. Odell (Scientific)	Experiment Developer (ED)	Naval Research Laboratory, Washington, D. C., 202-767-2747
Mr. W. Jenkins	MSFC Experiment Manager (EM)	MSFC, Bldg. 4201, PM-SL-DP, 205-453-3183
Mr. A. W. Bearskin	S&E Integration Engineer (IE)	MSFC, Bldg. 4610, S&E-ASTN-SDI, 205-453-3811
Mr. W. R. Bock	Technical Discipline Manager (TDM)	MSFC, Bldg. 4610, S&E-ASTN-SDF, 205-453-3810
Mr. J. E. Meyers	Experiment Operations Engineer (EOE)	Telodyne Brown Engineering Company, Huntsville, Alabama, 202-532-1561
Mr. S. Metzler	Mission Operations Design Support (MODS)	Martin Marietta Corporation, Denver, Colorado, 303-794-5211, ext. 3174
Dr. J. Meeker	MMC Experiment Integration Engineer (EIE)	Bendix Corporation, Denver, Colorado, 303-761-1163, ext. 227
Mr. R. Carr	MSC Experiment Flight Controller (EFC)	MSC, Bldg. 30, FC6, 713-483-4616

TABLE K-111. EXPERIMENT S-009, NUCLEAR EMULSION EVALUATION SEQUENCE (Sheet 2 of 14)

Operation Step Number*	Return			Data				Contingencies	Remarks
	Recorder Number	Measurement Name, Number, and Signal	Telemetry Assignment Channel	Frequency*	Range and Dimension of Variables	Saturation Check	Abnormality		
P - 90 min GMT 19:07 for SL-1/SL-2		Experiment Evaluation Team manned and available. Contact Technical Discipline Manager for Experiment S-009, S&E-ASTN-SD; HOSC Telephone No. TBD, Astronautics Laboratory Telephone No. 205-453-3810. Reference: Skylab Flight Plan, SL-1/SL-2 Summary Timelines, MSC-03625, latest revision, and Skylab Experiment Operations Handbook, Volume II: Experiment Operational Procedures MSC-00924, latest revision.							See Contingency Plan Number
P - 52 min GMT 19:45 for SL-1/SL-2		Commence experiment preparation (ground action).							
P 1.0		Determine carrier/experiment support instrumentation status.							
P 1.1		Acquire status and evaluate the performance for the following measurements:							
P 1.1.1	TBS	Volt, AM Bus No. 2 Voltage Comdr. -Vdc Monitor MI56-513	H	C	Range: 0 to 35 Vdc			N	P111A1 P111A2 P111B1 P111B2 P111C1 P111C2
P 1.1.2	TBS	Temp, Internal Fwd. Cyl. 6 C0039-807	H	C	Read: 24 to 30 Vdc Range: -5 to 45 °C Read: 15.5 to 32.2 °C	21 to 31 Vdc 1.6 to 40.5 °C		A	P112A1

* P - Preparation
 O - Operations
 T - Termination
 L - Liftoff (Booster)
 ** E - Event
 H - Housekeeping
 A - Analog
 D - Digital
 *** C - Continuous
 I - Intermittent
 D - Discrete
 (Specified number of times)
 **** R - Real Time
 N - Near/Real Time
 A - All Time

ASTN-72-1-OT (Jan 72)

TABLE K-III. EXPERIMENT S-009, NUCLEAR EMULSION EVALUATION SEQUENCE (Sheet 3 of 14)

Operation Number*	Data										Contingencies			
	Recorder Number	Measurement Number and Signal	Return		Function**		Range and Dimension of Variables		Limits of Concern		Satisfactory Annually Check	Remarks***	See Contingency Plan Number	Remarks
			Telemetry Channel	Assignment	Function**	Range and Dimension of Variables	Limits of Concern	Satisfactory Annually Check						
P 1.1.3	TBS	Temp, Internal Fwd. Cyl. 2 C0005-807	WPIA140A84LP29	H	C	Range: -5 to 45 °C Read: 15.5 to 32.2 °C	1.6 to 40.5 °C	A	P113A1					
P 1.1.4	TBS	Temp, Atmospheric Gas 1 C0018-807	WPIA114A63LC23	H	C	Range: -5 to 45 °C Read: 15.5 to 32.5 °C	1.6 to 40.5 °C	A	P114A1					
P 1.1.5	TBS	Temp, Atmospheric Gas 2 C0019-807	WPIA104A72LB26	H	C	Range: -5 to 45 °C Read: 15.5 to 32.5 °C	1.6 to 40.5 °C	A	P115A1					
P 1.1.6	TBS	Temp, TCS Fwd. Compt. No. 6 Transducer Assy. C7044-436	WP1B050A13LM03	H	C	Range: -17.75 to 48.9 °C Read: 18.3 to 29.4 °C	TBD	A	P116A1					
P 1.1.7	TBS	OA Ephemeris Data Measurement No. TBD	TBD	H	C	Range: TBD Read: TBD	TBD	N						

** P - Preparation
 O - Operations
 T - Termination
 L - Liftoff (Booster)

** E - Event
 H - Housekeeping
 A - Analog
 D - Digital

*** C - Continuous
 I - Intermittent
 D - Discrete
 (Specified number of times)

**** R - Real Time
 N - Near/Real Time
 A - All Time

TABLE K-III. EXPERIMENT S-009, NUCLEAR EMULSION EVALUATION SEQUENCE (Sheet 4 of 14)

Operation Step Number*	Return				Data				Contingencies	
	Measurement Number and Signal	Telemetry Channel	Function**	Frequency***	Range and Direction of Variables	Limits of Concern	Satisfactory Check	Remarks****	See Contingency Plan Number	Remarks
P 1.1.8	OA Attitude	H	C		Range: TBD Read: TBD	TBD	N			
P - 22 min GMT 20:15 for SL-1/ SL-2	Measurement No. TBD Commence experiment preparation (flight action).									

* P - Preparation
 O - Operations
 T - Termination
 L - Liftoff (Booster)

** E - Event
 H - Housekeeping
 A - Analog
 D - Digital

*** C - Continuous
 I - Intermittent
 D - Discrete
 (Specified number of times)

**** R - Real Time
 N - Near/Real Time
 A - All Time

ASTN-72-1-OT (Jan 72)

TABLE K-111. EXPERIMENT S-009, NUCLEAR EMULSION EVALUATION SEQUENCE (Sheet 5 of 14)

Operation Step Number*	Crewman:*	Test Procedure	Evaluation (Check One)		See Contingency Plan Number	Remarks
			Satisfactory	Anomally		
P 2.0	PLT	Set up and prepare to initiate experiment operations.				
P 2.1		Verify the following switch positions:				
P 2.1.1		cb S-009 - OPEN (panel 202 in STS)				
P 2.1.2		POWER - OFF				
P 2.1.3		INITIATE/RESET - INITIATE				
P 2.2		Release launch cable restraint.				
P 2.3		Disengage experiment housing launch lock pin (rotate knob ccw to disengage).				
P 2.4		Using β angle knob, rotate experiment housing until the protective screen is approximately normal to the support structure and facing the operator, and engage knob thumb latch in a load position detent.			P24A1 P24A2 P24B1 P24B2 P24B3	Carrier frame segment swings inboard 15°.
P 2.5		Release 2 slide fasteners on front of frame support structure.				
P 2.6		Pull mushroom lock knob on top of support structure and hold.				
P 2.7		Swing carrier frame segment of support structure to open position and release mushroom lock knob to locked position. Verify carrier frame segment locked open.				
P 2.8		Release 2 slide fasteners on protective screen and rotate screen to full open position.				
P 2.9		Release 4 slide fasteners on the carrier assembly and open the gates.				
P 2.10		Open 2 bearing spring latches on the carrier assembly.				
P 2.11		Retrieve detector package from OWS film vault.				

*P - Preparation
 O - Operations
 T - Termination
 L - Lift-off (Booster)
 **TP - Test Pilot (Commander)
 OBS - Observer (Science Pilot)
 PLT - Pilot
 ALL - TP/OBS/PLT

TABLE K-III. EXPERIMENT S-009, NUCLEAR EMULSION EVALUATION SEQUENCE (Sheet 6 of 14)

Operation Step Number*	Crewman: *	Test Procedure	Evaluation (Check One)		See Contingency Plan Number	Remarks
			Satisfactory	Anomally		
P 2.12		Release hook latches on detector package and detent to full open position. Unfold detector package to open position.				
P 2.13		Install detector package in the experiment housing using the alignment marks on detector package and carrier assembly.				
P 2.14		Close 2 bearing spring latches on the carrier assembly.				
P 2.15		Close carrier assembly gates and latch 4 slide fasteners.				
P 2.16		Rotate protective screen to close position and latch 2 slide fasteners.				
P 2.17		Press thumb latch on β angle correction knob and rotate the experiment housing to zero β angle position, and release thumb latch to detent.			P217A1 thru P217A3	
P 2.18		Pull mushroom lock knob on top of support structure and hold.				
P 2.19		Swing carrier frame segment of support structure to closed position and release mushroom lock knob to locked position. Verify carrier frame segment locked closed.				
P 2.20		Latch 2 slide fasteners on front of frame support structure.				
P 2.21		Position and set switches:				
P 2.21.1		cb S-009 - CLOSE			P2211A1 thru P2211A8	
P 2.21.2		POWER - ON			P2212A1 thru P2212A3	
P 2.21.3		INITIATE/RESET - RESET			P2213A1 thru P2213A2	
P 2.21.4		POWER - OFF			P2214A1 thru P2214A6	Detector package will close.
P 2.22		Press thumb latch on β angle correction knob and rotate experiment housing to desired β angle setting:				Ground will supply β angle setting. Uplink: S-009 Pad, GMT 19:02

*P - Preparation
 O - Operations
 T - Termination
 L - Lift-off (Booster)
 **TP - Test Pilot (Commander)
 OBS - Observer (Science Pilot)
 PLT - Pilot
 ALL - TP/OBS/PLT

NSFC - One Time Form 17-1 (March 1972)

TABLE K-III. EXPERIMENT S-009, NUCLEAR EMULSION EVALUATION SEQUENCE (Sheet 7 of 14)

Operation Step Number*	Crewman**	Test Procedure	Evaluation (Check One)		See Contingency Plan Number	Remarks
			Satisfactory	Anomally		
P 2.23		Verify proper setting of PERIOD ADJUST rheostat. If setting is incorrect, unlock and turn knob to proper setting and lock: P _____				Ground will verify that preflight setting is correct or supply correct setting.
P 2.24		INITIATE/RESET switch - RESET (verify).				Uplink: S-009 Pad, GMT 19:02
P - 10 min GMT 20:27 for SL-1/SL-2	Prepare to initiate experiment operations:					
P 3.0	PLT	Position and set switches.				
P 3.1		POWER - ON.				Electronics equipment warmup not to exceed 30 min.
O = 0.0 min GMT 20:37 for SL-1/SL-2	Commence experiment operations:					
O 1.0	PLT	INITIATE/RESET switch - Initiate, when crossing the 30° N LAT going S.			O10A1 thru O10A22; O10B1 and O10B2; O10C1 thru O10C4, O10D1 thru O10D8; O10E1 and O10E2	Ground will furnish GMT for crossing of 30° N LAT going S. Detector package will open.
O 2.0	PLT	Perform experiment β angle and timer updates.				Changes in experiment viewing angle necessitated by changes in β angle will be furnished by ground as β angle adjust knob settings. Record β angle settings in experiment logbook.
O 2.1		Press thumb latch on β angle adjust knob and rotate experiment housing to desired β angle, adjust knob setting.				Detector package will close if open and remain closed if already closed.
O 2.2		INITIATE/RESET switch - RESET (verify).				

**TP - Test Pilot (Commander)
OBS - Observer (Science Pilot)
PLT - Pilot
ALL - TP/OBS/PLT

TABLE K-111. EXPERIMENT S-009, NUCLEAR EMULSION EVALUATION SEQUENCE (Sheet 8 of 14)

Operation Step Number*	Crewman†	Test Procedure	Evaluation (Check One)		See Contingency Plan Number	Remarks
			Satisfactory	Anomally		
O 2.3		Unlock PERIOD ADJUST rheostat and turn knob to proper setting and lock, if required.				Ground will calculate new setting based on error in time of opening or closing of detector package supplied to ground by the crew. Ground will furnish GMT for crossing of the 30° N LAT going S.
O 2.4		Position INITIATE/RESET - INITIATE when crossing the 30° N LAT going S if required.				

*P - Preparation
 O - Operations
 T - Termination
 L - Lift-off (Booster)
 **TP - Test Pilot (Commander)
 OBS - Observer (Science Pilot)
 PLT - Pilot
 ALL - TP/OBS/PLT

MFPC - One Time Form 17-1 (March 1972)

TABLE K-III. EXPERIMENT S-009, NUCLEAR EMULSION EVALUATION SEQUENCE (Sheet 9 of 14)

Operation Step	Data										Contingencies	
	Return					Evaluation					Remarks	See Contingency Plan Number
	Recorder Number	Measurement Name, Number, and Signal	Telemetry Channel Assignment	Function*	Range and Dine and Range of Variables	Limits of Concern	Safety/Check	Remarks**	Remarks	See Contingency Plan Number		
O 2.5	Acquire status and evaluate the performance for the following measurements as required:											
O 2.5.1	TBS	Temp, Internal Fwd. Cyl. 6		H C	Range: -5 to 45 °C Read: 15.5 to 32.2 °C	1.6 to 40.5 °C		A				
		C0039-807	WP1A065A47LN19									
O 2.5.2	TBS	Temp, Internal Fwd. Cyl. 2		H C	Range: -5 to 45 °C Read 15.5 to 32.2 °C	1.6 to 40.5 °C		A				
		C0005-807	WP1A140A84LP29									
O 2.5.3	TBS	Temp, Atmospheric Gas 1		H C	Range: -5 to 45 °C Read: 15.5 to 32.2 °C	1.6 to 40.5 °C		A				
		C0018-807	WP1A114A63LC23									
O 2.5.4	TBS	Temp, Atmospheric Gas 2		H C	Range: -5 to 45 °C Read: 15.5 to 32.5 °C	1.6 to 40.5 °C		A				
		C0019-807	WP1A104A72LB26									
O 2.5.5	TBS	Temp, TCS Fwd. Compt. No. 6 Transducer Assy.		H C	Range: -17.75 to 48.9 °C	TBD		A				
		C7044-436	WP1B050A13LM03		Read: 18.3 to 29.4 °C							

* P - Preparation
O - Operations
T - Termination
L - Liftoff (Booster)
ASTN-72-1-OT (Jan 72)

** E - Event
H - Housekeeping
A - Analog
D - Digital

*** C - Continuous
I - Intermittent
D - Discrete
(Specified number of times)

**** R - Real Time
N - Near/Real Time
A - All Time

TABLE K-III. EXPERIMENT S-009, NUCLEAR EMULSION EVALUATION SEQUENCE (Sheet 10 of 14)

Operation Step Number*	Return				Data				Contingencies		
	Recorder Number	Measurement Name, Number, and Signal	Telemetry Channel	Function**	Frequency***	Range and Dimension of Variables	Limits of Concern	Satisfactory Anomaly Check	Remarks****	See Contingency Plan Number	Remarks
O 2.5.6	TBS	OA Ephemeris Data Measurement No. TBD		H C		Range: TBD Read: TBD	TBD		N		
O 2.5.7	TBS	OA Attitude Measurement No. TBD		H C		Range: TBD Read: TBD	TBD		N		

* P - Preparation
 O - Operations
 T - Termination
 L - Liftoff (Booster)
 ** E - Event
 H - Housekeeping
 A - Analog
 D - Digital
 *** C - Continuous
 I - Intermittent
 D - Discrete
 (Specified number of times)
 **** R - Real Time
 N - Near/Real Time
 A - All Time

TABLE K-III. EXPERIMENT S-009, NUCLEAR EMULSION EVALUATION SEQUENCE (Sheet 11 of 14)

Operation Step Number*	Crewman**	Test Procedure	Evaluation (Check One)		See Contingency Plan Number	Remarks
			Satisfactory	Anomally		
T = 0 min GMT 20:12 for SL-1/SL-2		Commence experiment termination.				
T 1.0	PLT	Verify detector package closed. If package is not closed, place INITIATE/RESET switch - RESET.			T10A1 thru T10A4	Detector package will close.
T 1.1		When detector package is fully closed, position and set switches:				Operation Step Number T 1.1 and subsequent step numbers may be ignored if immediate detector package removal is desired.
T 1.1.1		POWER - OFF				
T 1.1.2		cb S-009 - OPEN (panel 202 in STS).				
T 1.2		Perform detector package removal and stowage.				
T 1.2.1		Position and set switches:				
T 1.2.1.1		cb S-009 - CLOSED				
T 1.2.1.2		POWER - ON				
T 1.2.1.3		INITIATE/RESET - INITIATE (verify).				
T 1.2.2		Release 2 slide fasteners on front of frame support structure.				
T 1.2.3		Pull mushroom lock knob on top of support structure and hold.				
T 1.2.4		Swing carrier frame segment of support structure to open position and release mushroom lock knob to locked position. Verify carrier frame locked open.				
T 1.2.5		Using the β angle knob, rotate experiment housing load position and engage thumb latch in load position detent until the protective screen is approximately normal to the support				

*P - Preparation
 O - Operations
 T - Termination
 L - Lift-off (Booster)
 **TP - Test Pilot (Commander)
 OBS - Observer (Science Pilot)
 PLT - Pilot
 ALL - TP/OBS/PLT

MSFC - One Time Form 17-1 (March 1972)

TABLE K-III. EXPERIMENT S-009, NUCLEAR EMULSION EVALUATION SEQUENCE (Sheet 12 of 14)

Operation Step Number*	Crewman*	Test Procedure	Evaluation (Check One)		See Contingency Plan Number	Remarks
			Satisfactory	Abnormal		
T 1.2.5 (Concluded)		structure and facing the operator, and engage knob thumb latch in a load position detent				
T 1.2.6		Release 2 slide fasteners on protective screen and rotate screen to full open position.				
T 1.2.7		Release 4 slide fasteners on carrier assembly and open gates.				
T 1.2.8		Open 2 bearing latches on carrier assembly.				
T 1.2.9		Remove detector package from experiment housing.				
T 1.2.10		Fold detector package to closed position and engage 2 hook latches (ensure hook latch detent closed).				
T 1.2.11		Stow detent package in the CM, stowage location A-5.				
T 1.2.12		Close 2 bearing latches on carrier assembly.				
T 1.2.13		Close carrier assembly gates and latch 4 slide fasteners.				
T 1.2.14		Rotate protective screen to closed position and latch 2 slide fasteners.				
T 1.2.15		Press thumb latch on β angle correction knob, rotate experiment housing to zero β angle position, and release thumb latch into detent.				
T 1.2.16		Pull mushroom lock knob on top of support structure and hold.				
T 1.2.17		Swing carrier frame segment of support structure to closed position and release mushroom knob to locked position. Verify carrier frame locked closed.				
T 1.2.18		Latch 2 slide fasteners on front of frame support structure.				
T 1.2.19		Position and set switches:				

*P - Preparation
 O - Operations
 T - Termination
 L - Lift-off (Booster)

**TP - Test Pilot (Commander)
 OBS - Observer (Science Pilot)
 PLT - Pilot
 ALL - TP/OBS/PLT

TABLE K-III. EXPERIMENT S-009, NUCLEAR EMULSION EVALUATION SEQUENCE (Sheet 13 of 14)

Operation Step Number*	Crewman**	Test Procedure	Evaluation (Check One)		See Contingency Plan Number	Remarks
			Satisfactory	Anomaly		
T 1.2.19.1		POWER - OFF				
T 1.2.19.2		cb S-009 - OPEN				

*P - Preparation
 O - Operations
 T - Termination
 L - Lift-off (Booster)
 **TP - Test Pilot (Commander)
 OBS - Observer (Science Pilot)
 PLT - Pilot
 ALL - TP/OBS/PLT

MSFC - One Time Form 17-1 (March 1972)

TABLE K-III. EXPERIMENT S-009, NUCLEAR EMULSION EVALUATION SEQUENCE (Sheet 14 of 14)

Operation Step Number*	Return				Data				Contingencies
	Measurement Name, Number, and Signal	Telemetry Channel	Function	Frequency**	Range and Dimension of Variables	Limits of Concern	Sensitivity Check	Evaluation Remarks***	
T 1. 2. 20	Acquire CM cabin temperature during detector package stowage, CM reentry and descent, and landing phases.								
T 1. 2. 20.1	Cabin Temperature	A	D (3)	Range: TBD	TBD		A		
T 1. 2. 21	CF0002	TBD		Read: TBD					
	Terminate all experiment activities.								

* P - Preparation
 O - Operations
 T - Termination
 L - Liftoff (Booster)

** E - Event
 H - Housekeeping
 A - Analog
 D - Digital

*** C - Continuous
 I - Intermittent
 D - Discrete
 (Specified number of times)

**** R - Real Time
 N - Near/Real Time
 A - All Time

ASTN-72-1-OT (Jan 72)

SECTION VIII.
EXPERIMENT S-009, NUCLEAR EMULSION MALFUNCTION
AND CONTINGENCY PLAN OUTLINE

NUCLEAR REACTOR EXPERIMENT OUTLINE - EXPERIMENT PREPARATION (P) (Sheet 1 of 7)

Operation Step Number	Experiment/Crew Tasks	Possible Malfunction	Contingency Plan	Remarks (malfunctions, corrections, results)
P 1.1.1	V, AM Bus No. 2 Voltage Condr. - Vdc Monitor	<p>P111A AM Bus No. 2 Voltage decreasing to 24 Vdc.</p> <p>P111B AM Bus No. 2 Voltage is ≥ 20 Vdc.</p>	<p>P111A1 No contingency plan is needed as long as AM bus voltage is $28 \pm \frac{1}{2}$ Vdc.</p> <p>P111A2 Do not begin automatic sequence operation of experiment if bus voltage drops below 24 Vdc.</p> <p>P111B1 Programmer logic cannot function properly and precludes automatic control and operation of the stepping motor.</p> <p>P111B2 The stepping motor can be manually controlled and operated using 8 Vdc.</p>	
P 1.1.2	Temp, Internal Fwd. Cyl. 6	<p>P111C AM Bus No. 2 Voltage is interrupted < 10 μsec.</p> <p>P112A Temperature measurement sensor malfunctions or fails.</p>	<p>P111C1 Programmer logic cannot function properly and upsets automatic operation of the experiment.</p> <p>P111C2 Reference:</p> <ul style="list-style-type: none"> • P111B2. <p>P112A1 Continue the experiment and acquire MDA thermal mapping data from the TBD Section, MSFC. See References 32 through 34 for selection of temperature sensing instrumentation for the MDA.</p>	
P 1.1.3	Temp, Internal Fwd. Cyl. 2	<p>P113A Temperature measurement sensor malfunctions or fails.</p>	<p>P113A1 Reference:</p> <ul style="list-style-type: none"> • P112A1. 	
P 1.1.4	Temp, Atmospheric Gas 1	<p>P114A Temperature measurement sensor malfunctions or fails.</p>	<p>P114A1 Reference:</p> <ul style="list-style-type: none"> • P112A1. 	

P

TABLE K-IV. EXPERIMENT S-009, NUCLEAR EMULSION MALFUNCTION AND CONTINGENCY PLAN OUTLINE - EXPERIMENT PREPARATION (P) (Sheet 2 of 4)

Operation Step Number	Experiment/Crew Tasks	Possible Malfunction	Contingency Plan	Remarks (malfunctions, corrections, results)
P 1.1.5	Temp, Atmospheric Gas 2	P115A Temperature measurement sensor malfunctions or fails.	P115A1 Reference: • P112A1.	
P 1.1.6	Temp, TCS Fwd. Compt. No. 6 Transducer Assy.	P116A Temperature measurement sensor malfunctions or fails.	P116A1 Continue the experiment and acquire OWS thermal mapping data of the film vault from the Payload Integration Section (S&E-ASTN-SDI), MSFC.	
P 2.4	Using β angle knob, rotate experiment housing until the protective screen is approximately normal to the support structure and facing the operator, and engage knob thumb latch in a load position.	P24A The β angle knob thumb latch will not engage in a load position.	P24A1 Rotate the experiment housing to load the detector package. Engage the launch lock pin against the top of the carrier assembly to secure the experiment housing. P24A2 After the detector package is loaded in the carrier assembly, disengage the launch lock pin and continue the experiment.	
		P24B The experiment housing will not rotate.	P24B1 Remove two screws from the protective screen assembly, using common screwdriver. P24B2 Unlatch two slide fasteners from protective screen, remove the screen assembly, and temporarily stow.	
P 2.17	Press thumb latch on β angle correction knob and rotate the experiment housing to zero β angle position. Release thumb latch to detent.	P217A Thumb latch or β angle knob will not detent.	P24B3 Continue experiment sequence of operations (Operation Step Number 2.9, Table K-III). P217A1 Engage the launch lock pin against the top of the carrier assembly to secure the experiment housing. P217A2 The launch lock pin may be used as a β angle locking mechanism for all negative β angle settings and	P

ASTN-OT-7 (Feb. 72)

TABLE K-IV. EXPERIMENT S-009, NUCLEAR EMULSION MALFUNCTION AND CONTINGENCY PLAN OUTLINE - EXPERIMENT PREPARATION (P) (Sheet 3 of 4)

Operation Step Number	Experiment/Crew Tasks	Possible Malfunction	Contingency Plan	Remarks (malfunctions, corrections, results)
P 2.17 (Concluded)			some positive β angle settings. Use pressure sensitive tape, wrapped about the experiment housing and carrier frame, to secure remainder of positive β angle positions.	
P 2.21.1	cb S-009 - CLOSE	P2211A cb S-009 fails to close.	<p>P217A3 Continue the experiment.</p> <p>P2211A1 Recycle cb S-009 - CLOSE.</p> <p>P2211A2 Position POWER switch - ON.</p> <p>P2211A3 Position INITIATE/RESET switch - RESET.</p> <p>P2211A4 If detector package closes, power is being supplied to the experiment.</p> <p>P2211A5 If detector package does not close, automatic and manual electrical control and operation of experiment is precluded.</p> <p>P2211A6 Position cb S-009 - OPEN.</p> <p>P2211A7 Continue experiment with detector package in carrier assembly. The operator physically handles (removing/installing and opening/closing) detector package during orbital data gathering and rejection modes.</p> <p>P2211A8 Acquire period open and close times, and β angle corrections from the ground for selected orbital revolutions.</p>	
P 2.21.2	POWER - ON	P2212A POWER switch fails open.	<p>P2212A1 Recycle POWER switch - ON.</p> <p>P2212A2 Position INITIATE/RESET switch - RESET.</p>	

P

TABLE K-IV. EXPERIMENT S-009, NUCLEAR EMULSION MALFUNCTION AND CONTINGENCY PLAN OUTLINE - EXPERIMENT PREPARATION (P) (Sheet 4 of 4)

Operation Step Number	Experiment/Crew Tasks	Possible Malfunction	Contingency Plan	Remarks (malfunctions, corrections, results)
P 2.21.2 (Concluded)			P2212A3 If detector package does not close, reference P2211A1 through P2211A5.	
P 2.21.3	INITIATE/RESET - RESET	P2213A INITIATE/RESET switch fails to close detector package.	P2213A1 Recycle INITIATE/RESET switch - RESET.	
P 2.21.4	POWER - OFF	P2214A POWER switch fails closed.	P2213A2 If detector package does not close, reference P2211A1 through P2211A5. P2214A1 Recycle POWER switch - OFF.	
			P2214A2 Position INITIATE/RESET switch - INITIATE.	
			P2214A3 If detector package opens, the POWER switch has failed closed.	
			P2214A4 Position INITIATE/RESET switch - RESET, and close detector package.	
			P2214A5 Position cb S-009 - OPEN.	
			P2214A6 Continue the experiment; the S-009 cb may be used as the POWER switch.	

P

TABLE K-V. EXPERIMENT S-009, NUCLEAR EMULSION MALFUNCTION AND CONTINGENCY PLAN OUTLINE - EXPERIMENT OPERATION (O) (Sheet 1 of 4)

Operation Step Number	Experiment/Crew Tasks	Possible Malfunction	Contingency Plan	Remarks (malfunctions, corrections, results)
O 1.0	INITIATE/RESET switch - INITIATE when crossing the 30° N LAT going S.	O10A INITIATE/RESET switch fails to open detector package.	<p>O10A1 Recycle INITIATE/RESET switch - INITIATE.</p> <p>O10A2 If detector package does not open, automatic operation is precluded.</p> <p>O10A3 Position INITIATE/RESET switch - RESET.</p> <p>O10A4 Rotate experiment housing to detector package load position and engage β angle knob latch to a lock position.</p> <p>O10A5 Swing protective and carrier assembly gate to open position.</p> <p>O10A6 Remove detector package from carrier assembly by unlatching two bearing latches, using small common screwdriver.</p> <p>O10A7 Latch detector package closed and stow nearby.</p> <p>O10A8 Position POWER switch - ON.</p> <p>O10A9 Detent detector package close limit switches (S3 or S4), using small common screwdriver and position INITIATE/RESET switch - INITIATE.</p> <p>O10A10 If stepping motor does not drive the bib screw latch block assemblies forward, position INITIATE/RESET switch - RESET.</p> <p>O10A11 Cycle detector package open limit switches (S5 and S6) using small common screwdriver.</p>	



TABLE K-V. EXPERIMENT S-009, NUCLEAR EMULSION MALFUNCTION AND CONTINGENCY PLAN OUTLINE - EXPERIMENT OPERATION (O) (Sheet 2 of 4)

Operation Step Number	Experiment/Crew Tasks	Possible Malfunction	Contingency Plan	Remarks (malfunctions, corrections, results)
			<p>O10A12 Reference:</p> <ul style="list-style-type: none"> • O10A9 • O10A10. <p>O10A13 Return detector package to OWS film vault.</p> <p>O10A14 If astronaut timeline permits, continue to investigate experiment electrical system for open conditions.</p> <p>O10A15 Return experiment housing to normal operating configuration.</p> <p>O10A16 Position POWER switch - OFF.</p> <p>O10A17 Position cb S-009 - OPEN.</p> <p>O10A18 Manual electrical control and operation of the experiment is precluded.</p> <p>O10A19 Manual operation of the detector package can be accomplished by acquiring the period open and close times, and β angle corrections from the ground for selected orbital revolutions.</p> <p>O10A20 Reference:</p> <ul style="list-style-type: none"> • P24B1. <p>O10A21 Retrieve detector package from OWS film vault, open to data gathering position, and install in carrier assembly using pressure sensitive tape.</p>	

O

TABLE K-V. EXPERIMENT S-009, NUCLEAR EMULSION MALFUNCTION AND CONTINGENCY PLAN OUTLINE - EXPERIMENT OPERATION (O) (Sheet 3 of 4)

Operation Step Number	Experiment/Crew Tasks	Possible Malfunction	Contingency Plan	Remarks (malfunctions, corrections, results)
		<p>O10B The following components fail open:</p> <ul style="list-style-type: none"> • cb S-009 (AM 202) • POWER switch (S1) • Rectifier (SCR5) • Cables and connectors • Maglatch relay (K2) • Stepping motor (M1) • Stepping motor driver (A2) • Limit switches (S3 to S6). <p>O10C Detector package partially open.</p>	<p>O10A22 Reference:</p> <ul style="list-style-type: none"> • P2211A7 • P2211A8. <p>O10B1 If the detector package is open, reference:</p> <ul style="list-style-type: none"> • P24B1 • P2211A5 • P2211A6 • P2211A7 • P2211A8. <p>O10B2 If the detector package is closed, reference:</p> <ul style="list-style-type: none"> • P24B1 • O10A19 • O10A21. <p>O10C1 Cycle INITIATE/RESET switch - INITIATE to attempt to open detector package.</p> <p>O10C2 If detector package does not fully open, check for binding components or possible gear train jamming.</p> <p>O10C3 Automatic operation of experiment may be precluded if malfunction cannot be resolved.</p> <p>O10C4 Continue experiment operations in manual electrical mode or reference:</p> <ul style="list-style-type: none"> • P24B1 • O10A19 • O10A21. 	



TABLE K-V. EXPERIMENT S-009, NUCLEAR EMULSION MALFUNCTION AND CONTINGENCY PLAN OUTLINE - EXPERIMENT OPERATION (O) (Sheet 4 of 4)

Operation Step Number	Experiment/Crew Tasks	Possible Malfunction	Contingency Plan	Remarks (malfunctions, corrections, results)
		<p>O10D Power interruption occurs < 10 μsec.</p> <p>O10E Detector package partially closed.</p>	<p>O10D1 Reference:</p> <ul style="list-style-type: none"> • P111C1. <p>O10D2 Position INITIATE/RESET switch - RESET (clock and programmer sequence will zero).</p> <p>O10D3 Acquire new GMT period adjust synchronization data.</p> <p>O10D4 Set PERIOD ADJUST rheostat as required.</p> <p>O10D5 Set up new β angle as required.</p> <p>O10D6 Position INITIATE/RESET switch - INITIATE, when crossing the 30° N LAT going S.</p> <p>O10D7 Several orbital revolutions will be required to establish programmer sequence lag or lead time.</p> <p>O10D8 Be prepared to open or close the detector package at the 25° S and 30° N LAT positions.</p> <p>O10E1 Visually check screen assembly to ensure that detector package latches are not fouled in screen. If the latches are fouled in the screen, remove the screen assembly. Reference:</p> <ul style="list-style-type: none"> • P24B1. <p>O10E2 Reference:</p> <ul style="list-style-type: none"> • O10C1 • O10C2 • O10C3 • O10C4. 	

O

TABLE K-VI. EXPERIMENT S-009, NUCLEAR EMULSION MALFUNCTION AND CONTINGENCY PLAN OUTLINE - EXPERIMENT TERMINATION (T)

Operation Step Number	Experiment/Crew Tasks	Possible Malfunction	Contingency Plan	Remarks (malfunctions, corrections, results)
T 1.0	Verify detector package closed. If package is not closed, place INITIATE/RESET switch - RESET.	T10A INITIATE/RESET switch fails to close the detector package.	<p>T10A1 Position POWER switch - OFF.</p> <p>T10A2 Position cb S-009 - OPEN.</p> <p>T10A3 Reference:</p> <ul style="list-style-type: none"> • O10A4 • O10A5 • O10A6. <p>T10A4 Close and stow latched detector package in OWS film vault.</p>	

T

SECTION IX.

EXPERIMENT S-009, NUCLEAR EMULSION MALFUNCTION ANALYSES

The material contained in this section is an excerpt from Reference 35.

8. NUCLEAR EMULSION EXPERIMENT, S009

The primary S009 operational functions requiring analysis are presented in Table 8.1 Figure 8.1 depicts the relationships used to develop this table.

Table 8.1 Operational Function and Malfunction Analysis Items, S009

Operational Function	Sub-function	Malfunction Analysis Item
8.1 Acquire Galactic Cosmic Ray Radiation Data	8.1.1 Provide Deployment and Sequencing	8.1.1.1 Deployment (Open/Close) or Sequencing Failure
	8.1.2 Provide Exposure Control	8.1.2.1 Shorted Detector Logic Output 8.1.2.2 Bus Power Interruption 8.1.2.3 RESET/INITIATE sw Open Failure or Inability to Actuate
	8.1.3 Provide Mechanical Control and Orientation	8.1.3.1 Beta Angle sel Failure 8.1.3.2 Carrier Frame Failure to Rotate 8.1.3.3 Fastener(s) Fail to Open/Close
	8.1.4 Provide Environmental Protection	8.1.4.1 Emulsion Material Punctured

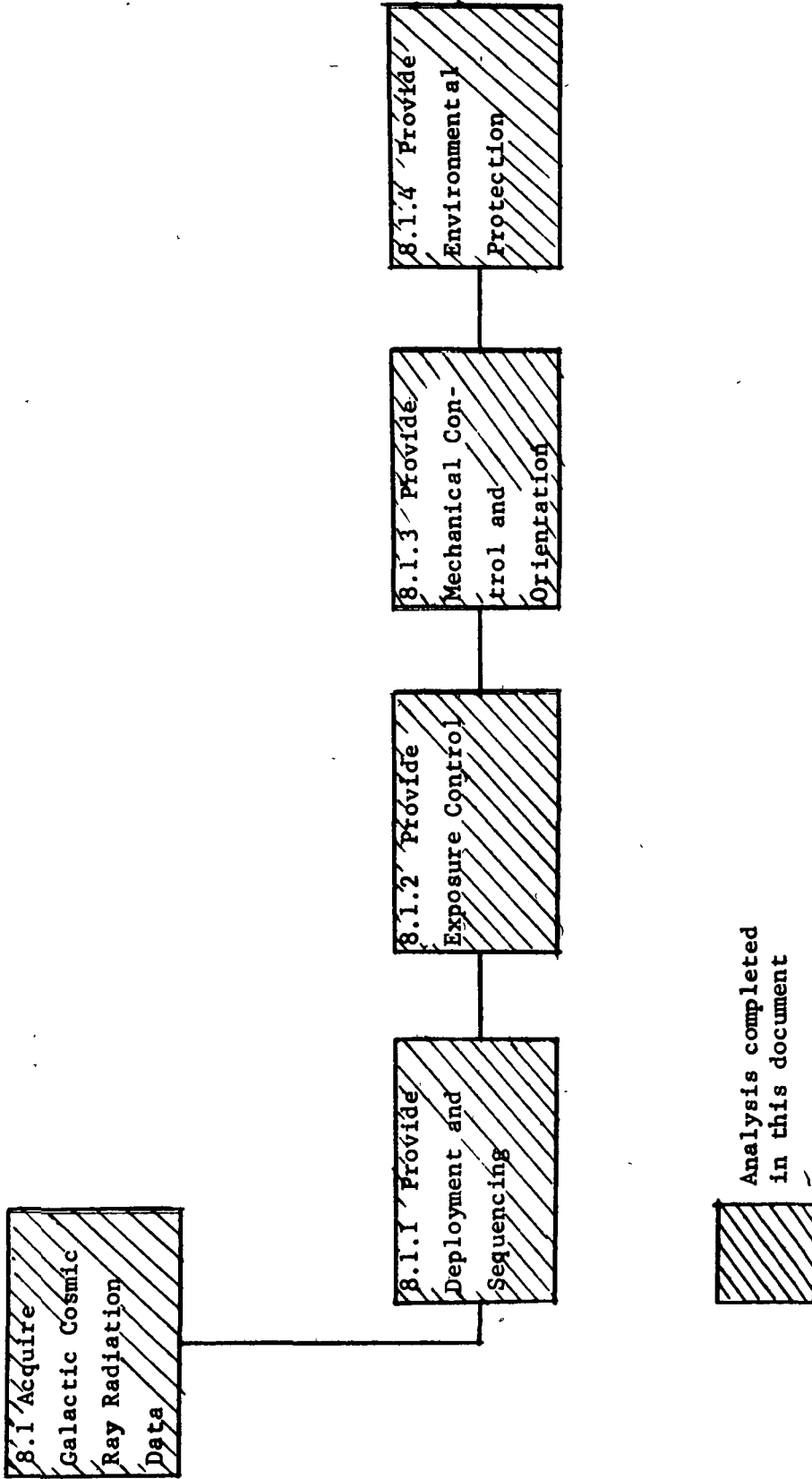

Figure 8.1 Functional Flow Diagram, S009

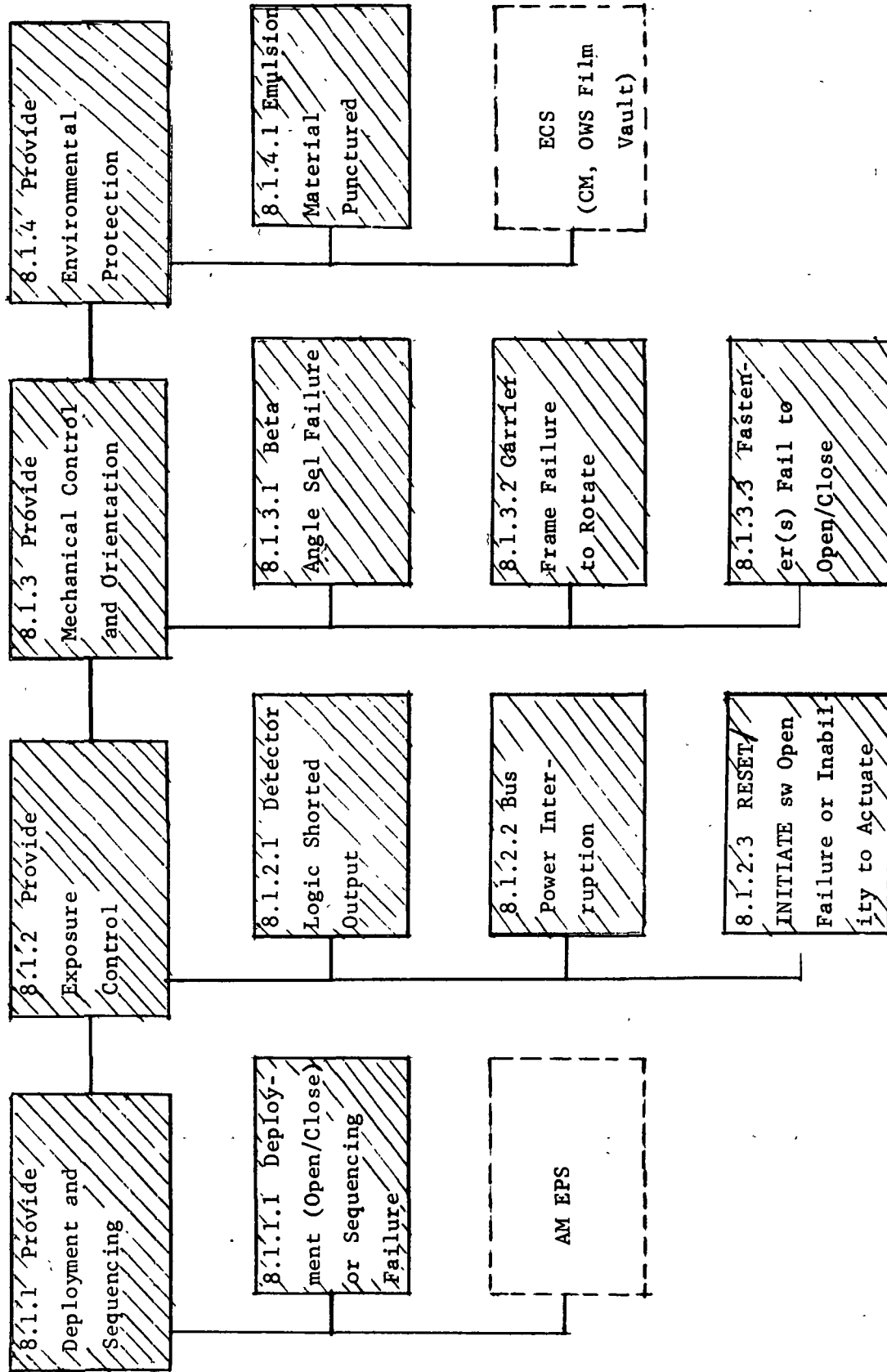

Figure 8.1 Malfunction Analysis Diagram, S009

MALFUNCTION ANALYSIS CHART, S009

MALFUNCTION	INDICATION			EFFECT		ACTION
	PRIMARY MEASUREMENTS	SUPPORT MEASUREMENTS	MISSION/CREW	SYSTEM/SUBSYSTEM	SYSTEM/INTERACTION	
<p>8. S009 Nuclear Emulsion Experiment</p> <p>8.1 Acquire Galactic Cosmic Ray Radiation Data</p> <p>8.1.1 Provide Deployment and Sequencing</p> <p>8.1.1.1 Deployment (Open/Close) or Sequencing Failure (cb S009 Failed Open, POWER sw Failed Open, Elec Cable & Conn Disconnected Rectifier (Q5) Open, K2 Relay Open, Motor Failure, Stepping Motor Driver Failure, Limit Switches Open, Gear Train Lockup, Detector Logic No Output, Both Limit Switches Fail to Deactivate, IC Transistor Open/Short, Binary Counter Transistor Failure, Logic Gates Erroneous or Erratic Output, Off Nominal Orbit, Power Interruption Downstream, or PERIOD ADJUST Wiper Open).</p>	<p>Crew Observation (U): Det Pkg remains open/close during experiment operation sensed by crew.</p> <p>sw in INITIATE pos and POWER sw in ON pos (in conjunction with M156 AM Bus 2 Voltage 28$\frac{1}{2}$ VDC nominal).</p>	<p>Crew Sensing: (U): No audible noise of gear train operation sensed by crew.</p> <p>Mission: None Crew: Timeline effect.</p>	<p>Loss of experiment S009 (open/close) orbit synchronization sequence.</p> <p>Possible degradation of data due to failure to close Det Pkg resulting in overexposure to SAA.</p>	<p>None</p>	<p>Ground Action: Phase D Crew Action: Phase D</p> <p>1. a. Place RESET/INITIATE sw in RESET pos to deploy Det Pkg closed if not within data acquisition latitudes, and</p> <p>b. Place POWER sw in OFF pos, and</p> <p>c. Ground to provide GMT initiate time, PERIOD ADJUST cont, and Beta Angle setting for re-initiating automatic sequencing, and</p> <p>d. Ten minutes prior to southward crossing 30° N lat place POWER sw ON, and</p> <p>e. Place RESET/INITIATE sw in INITIATE pos at 30° N lat, and</p> <p>f. Observe Det Pkg deploy close at 25° S lat crossing (within 19.1 min \pm .2 min), and</p> <p>2. a. Same as 1a. b. Place POWER sw OFF. c. Ground to provide GMT open/close time per orbit and Beta Angle settubgm abd d. Place POWER sw in ON pos, and e. Use RESET/INITIATE sw to open/close pkg, and</p>	

MISSION PHASES: A All Phases
B Boost to Orbit
C Activation
D 1st Visitation
E 1st Storage
F 2nd Visitation
G 2nd Storage
H 3rd Visitation

MALFUNCTION ANALYSIS CHART, S009

MALFUNCTION	INDICATION		EFFECT			ACTION
	PRIMARY MEASUREMENTS	SUPPORT MEASUREMENTS	MISSION/CHK W	SYSTEM/SUBSYSTEM	SYSTEM/INTERACTION	
B.1.1.1 Deployment (Open/Close) or Sequencing Failure (Continued)						<p>CREW OR COMM/NU</p> <p>3. a Place POWER sw in OFF pos, and b. Check cable and connector to assure proper mating, and c Place POWER sw in ON pos, and d Same as steps 1c through f, and 4. a. Place POWER sw in OFF pos, and b Utilize standard screw-driver (Ref 6) and manually cycle appropriate limit switches to reverse direction of Det Pkg, and c. Check and adjust mating of Det Pkg with limit switch contacts, and d Place POWER sw in ON pos and place RESET/INITIATE sw in appropriate pos, and e Same as steps 1c through f, and 5. a. Cycle cb S009, POWER sw, and RESET/INITIATE sw, and b. For Det Pkg open, remove Det Pkg and stow in OWS Film Vault per Ref 5 Procedures 08.001.004-0 and 08.001.005-0, and c. Ground to provide GMT insert and removal time and Beta Angle setting, and</p>

MISSION PHASES: A All Phases
 B Boost to Orbit
 C Activation
 D 1st Visitation
 E 1st Storage
 F 2nd Visitation
 G 2nd Storage
 H 3rd Visitation

MALFUNCTION ANALYSIS CHART, S009

MALFUNCTION	INDICATION		EFFECT			ACTION
	PRIMARY MEASUREMENTS	SUPPORT MEASUREMENTS	MISSION/CREW	SYSTEM/SUBSYSTEM	SYSTEM/INTERACTION	
8.1.1.1 Deployment (Open/Close) or Sequencing Failure (Continued)						CREW OK COMMAND
8.1.2 Provide Exposure Control						5. d. Unstow Det Pkg and insert for data acquisition latitudes per Ref 5 Procedures 08.001.001-0 and 08.001.002-0, and e. Same as step 5b and repeat, or 6. a. Cycle cb S009, POWER sw, and RESET/INITIATE sw, and b. For Det Pkg closed or partially open/close utilize standard screwdriver (Ref 6) to lift up bib screw latches, and c. Manipulate Det Pkg for removal, and d. Stow Det Pkg in OWS Film Vault per Ref 5 Procedure 08.001.005-0, and e. Same as step 5c, and f. Secure Det Pkg exposure faces open in Experiment Housing by means of pressure sensitive tape for data acquisition latitudes, and 8. Same as step 5b and repeat Ground Action: Phase D Crew Action: Phase D
8.1.2.1 Shorted Detector Logic Output (NU) Det Pkg continually oscillates open/close.	Crew Observation (U): Det Pkg continually oscillates open/close.	None	Mission: None Crew: Timeline effect.	Loss of Detector Logic programmed exposure sequence control. Data degradation due to failure to deploy Det Pkg closed.	None	1. a. Place POWER sw in OFF pos when Det Pkg oscillates to closed configuration, and b. Ground to provide GMT open/close time per orbit and Beta Angle setting, and c. Utilize POWER sw to open/close Det Pkg.

MISSION PHASES: A All Phases
B Boost to Orbit
C Activation
D 1st Visitation
E 1st Storage
F 2nd Visitation
G 2nd Storage
H 3rd Visitation

MALFUNCTION ANALYSIS CHART, S009

MALFUNCTION	INDICATION	SUPPORT MEASUREMENTS	MISSION/CRFN	SYSTEM/SUBSYSTEM	SYSTEM/INTERACTION	ACTION
8.1.1.2.2 Bus Power Interruption (AM Bus 2)	<p>MI56 AM Bus 2 Voltage (recorded) (U): ≤ 20 VDC for > 10 microseconds</p> <p>Note: Sample rate for this measurement is 1.25 sps.</p>	<p>Crew Observation (U): Det Pkg does not open/close automatically during experiment operation when RESET/INITIATE sw in POWER sw in ON pos (This cue inconclusive without Primary Measurement)</p>	<p>Mission: None</p> <p>Crew: Timeline effect.</p>	<p>Power interruption of ≥ 10 microseconds precludes automatic orbit synchronization.</p> <p>Possible loss of cosmic ray radiation data due to failure to deploy Det Pkg closed.</p>	None	<p>1. Same as 8.1.1 step 5b if power has not been reapplied, and</p> <p>2. Same as 8.1.1 steps 1a through f.</p>
8.1.1.3 RESET/INITIATE sw Open Failure or Inability to Actuate	<p>Crew Observation (U): Det Pkg does not open/close by RESET/INITIATE sw activation but deploys automatically by Detector Logic control.</p>	<p>None</p>	<p>Mission: None</p> <p>Crew: Timeline effect.</p>	<p>Loss of RESET/INITIATE sw capability to reset Detector Logic for re-sequencing orbit synchronization.</p> <p>Partial degradation of S009 Experiment data due to failure to deploy Det Pkg closed.</p> <p>POWER ON/OFF sw unable to re-synchronize orbit sequence due to memory logic overshoot.</p>	None	<p>1. a. Cycle RESET/INITIATE sw, and</p> <p>b. Ground to provide PERIOD ADJUST cont setting, and</p> <p>2. Same as 8.1.1 steps 5b through e or 6b through g</p>

MISSION PHASES: A All Phases
 B Boost to Orbit
 C. Activation
 D. 1st Visitation
 E. 1st Storage
 F. 2nd Visitation
 G. 2nd Storage
 H. 3rd Visitation

MAJUNCTION ANALYSIS CHART - S009

MAJUNCTION		INDICATION		FUTHC			ACTION	
MAJUNCTION OR CONDITION	PRIMARY MEASUREMENTS	SUPPORT MEASUREMENTS	MISSION/CREW	SYSTEM/SUBSYSTEM	SYSTEM/INTERACTION	CREW OR COMM. IN.		
8.1.3 Provide Mechanical Control and Orientation								
8.1.3.1 Beta Angle sel Failure (Spring Failure or Set Screw Failure)	Crew Observation (U): Will not maintain a set position. Crew Observation (U): Experiment Housing rotates freely.	None	Mission: None Crew: Timeline effect.	Loss of Experiment S009 mechanical control capability to maintain Det Pkg positioned perpendicular to the orbital plane. Degraded S009 Experiment data due to failure to control roll position of Det Pkg.	None	Ground Action: Phase D Crew Action: Phase D 1. Recycle detent latch and rotate Beta Angle sel, and 2. a. Set Beta Angle sel to ground provided position, and b. Utilize launch lock to secure set position.		
8.1.3.2 Carrier Frame Failure to Rotate (Experiment Activation)	Crew Sensing (U): Carrier Frame does not rotate.	None	Mission: None Crew: Timeline effect.	Loss of Experiment S009 carrier frame rotational capability for readily inserting Det Pkg.	None	Ground Action: Phase D Crew Action: Phase D 1. a. Verify lock control and fasteners released, and b. Rotate Beta Angle sel to maximum clockwise position, and c. Utilize standard screwdriver (Ref 6) to remove hinge screws from protective screen, and d. Release screen fasteners, and e. Same as 8.1.1 step 5d and replace protective screen by securing fasteners, and f. Same as 8.1.1 step 1c through f.		

MISSION PHASES: A All Phases
B Boost to Orbit
C Activation
D 1st Visitation
E 1st Storage
F 2nd Visitation
G 2nd Storage
H 3rd Visitation

MALFUNCTION ANALYSIS CHART, S009

MALFUNCTION	INDICATION			EFFECT			ACTION CREW OR COMM-ND
	PRIMARY MEASUREMENTS	SUPPORT MEASUREMENTS	MISSION/CREW	SYSTEM/SUBSYSTEM	SYSTEM/INTERACTION		
8.1.3.3 Fasteners Fail to Open/Close (Gate, Carrier Frame, or Screen)	Crew Sensing (U): Fasteners do not open/close when actuated by crew.	None	Mission: None Crew: Timeline effect.	Loss of Experiment S009 capability to actuate gate, carrier frame, or screen fasteners.	None	Ground Action: None Crew Action: Phase D	
8.1.4 Provide Environmental Protection	Detector Package (U): Crew inspection of Det Pkg indicates emulsion material has been severely lacerated or punctured.	None	Mission: None Crew: Timeline effect.	Degradation of S009 Experiment data.	None	Ground Action: None Crew Action: Phase D	
8.1.4.1 Emulsion Material Punctured						1. a. Failed open, secure fastener(s) by means of pressure sensitive tape, and b. Drive fastener(s) closed utilizing ballpeen hammer, (Ref 6). Ground Action: None Crew Action: Phase D 1. Repair punctured area by means of pressure sensitive tape, and 2. Continue S009 Experiment operation, and 3. Possible consideration of re-supply of Det pkg for SL-3, Phase F.	

MISSION PHASES: A All Phases
B Boost to Orbit
C Activation
D 1st Visitation
E 1st Storage
F 2nd Visitation
G 2nd Storage
H 3rd Visitation

SECTION X. CONCLUSIONS AND RECOMMENDATIONS

1. The S-009 experiment design requires minimum astronaut involvement for operation. The astronaut must set up the experiment and make some minor adjustments, and start the experiment. The electronics subassembly provides the necessary control sequencing, timing synchronization, and switching circuitry to permit unattended operation of the experiment. About once a day the astronaut must make a time adjustment to the electronics subassembly to ensure that the detector package opens and closes at the proper times in the orbit. If the programmer, clock pulse generator, stepping motor drives, or other components in the electronics subassembly should fail while the detector package is open, and the package passes into the data rejection zones (north of the 30° N LAT, and south of the 25° S LAT), there is a high probability that the emulsion stack will be subjected to radiation fogging. This could cause loss of cosmic track data, or possibly preclude experiment cosmic data altogether. It is recommended that the astronaut visually check the detector package open or closed position more frequently than once during a 24 hr period. The astronaut should correlate the experimental data gathering and rejection modes with the earth latitude positions during experiment operations. The astronaut should become aware of the package being closed when the OA is below the 25° S LAT, especially during those orbital revolutions that pass through the South Atlantic Anomaly (SSA). It is expected that this recommendation will probably impact the astronaut's (PLT) timeline during SL-1/SL-2.
2. It is concluded that the programmer is probably the most important single piece of control electronics in the experiment. Any miscount of the binary counters could preclude the automatic sequence of operation of the experiment. However, this situation would not necessarily preclude the ability of the experiment to gather data. The Skylab crew does have the option to open and close the detector package (using the INITIATE/RESET switch) for selected orbital revolutions at the proper earth latitude.
3. Much concern has been raised about the relative noisiness of the S-009 experiment during the opening and closing of the detector package. The problem, as approached by the review item discrepancy writeups, shows that subjective criteria were used to determine the relative noise of S-009 operation. It is expected, however, that the noise problem can be either verified or relegated to an insignificant environmental consideration after the MDA/STS

Systems Integration test. This test is scheduled to begin in April 1972 at MDAC-ED.

4. It would be highly advantageous to NRL and the experiment performance evaluation function to have the experiment housing instrumented with telemetry that indicated when the detector package open and closed events occurred. The event signals could be correlated to the period adjust, β angle, and data gathering/rejection information for each orbital revolution. If the electronics subassembly should fail, the ground personnel could request that the flight crew take appropriate action to continue the experiment on a manual basis, or save the acquired detector package scientific data. Further coordination between NRL and MSFC is needed to determine the feasibility, program impact, and desirability of incorporating telemetry link to the experiment.
5. A request for deviation was submitted by NRL so that Esso Beacon 325 grease (MIL-G-3278A) can be used onboard the MDA. A waiver was issued and granted by MSFC to NRL, as indicated by PM-SL-DP, NRL, and S&E-ASTN-M. However, S&E-ASTN-SDI and MMC cannot find the official MSFC waiver. Only a memorandum indicates that a waiver was issued. It is important that the waiver be found and verified during the MSFC Design Certification Review; otherwise, acceptance of the experiment by KSC could be a problem.

REFERENCES

1. Experiment Requirements Document for S-009. Repository No. SE-010-002-2H, Marshall Space Flight Center, Huntsville, Alabama, January 20, 1970.
2. Mission Requirements for Skylab Missions SL-1/SL-2, SL-3, and SL-4. Vol. I, 1-MRD-001D, Marshall Space Flight Center, Huntsville, Alabama, Manned Spacecraft Center, Houston, Texas, November 1, 1971.
3. Skylab Experiment Operations Handbook. Vol. I: Experiment Descriptions, MSC-00924, Manned Spacecraft Center, Houston, Texas, November 19, 1971.
4. Skylab Program Operational Data Book. Vol. I: Experiments Performance Data, Experiment S-009, MSC-01549, Manned Spacecraft Center, Houston, Texas, September 1970.
5. Skylab Flight Plan for SL-1/SL-2, SL-3, and SL-4. Rev. A, unnumbered, Manned Spacecraft Center, September 27, 1971.
6. Skylab Program Directive No. 43. M-D ML3200.125, NASA Office of Manned Space Flight, Washington, D.C., April 10, 1970.
7. Nuclear Emulsion Experiment S-009. CDR Documentation Packet, Naval Research Laboratory, Washington, D.C., July 30, 1970.
8. Failure Mode and Effects Analysis and Single Failure Point Summary for Nuclear Emulsion Experiment S-009. NRL-ESD-23/102, Rev. A, Manned Spacecraft Center, Houston, Texas, October 1970.
9. Carrier Frame Subassembly, Experiment S-009. Dwg. No. 681303, Naval Research Laboratory, Washington, D.C., November 5, 1970.
10. Lexan Gear and Handle Details, Experiment S-009. Dwg. No. 681365, Naval Research Laboratory, Washington, D.C., December 23, 1970.
11. Gear Box Subassembly, Experiment S-009. Dwg. No. 681317, Naval Research Laboratory, Washington, D.C., November 4, 1970.

REFERENCES (Continued)

12. Memorandum PM-SL-DP (364-71). Marshall Space Flight Center, Huntsville, Alabama, July 22, 1971.
13. Memorandum S&E-ASTN-MX (71-134). Marshall Space Flight Center, Huntsville, Alabama, February 28, 1971.
14. Memorandum 4708. Naval Research Laboratory, Washington, D.C., June 15, 1971.
15. Bib Screw (Modified), Experiment S-009. Dwg. No. 681327, Naval Research Laboratory, Washington, D.C., November 4, 1970.
16. Latch Details, Experiment S-009. Dwg. No. 681313, Naval Research Laboratory, Washington, D.C., November 4, 1970.
17. Latch and Latch Spring, Experiment S-009. Dwg. No. 681374, Naval Research Laboratory, Washington, D.C., November 4, 1970.
18. Screen Subassembly, Experiment S-009. Dwg. No. 681352, Naval Research Laboratory, Washington, D.C., October 27, 1970.
19. Detector Package, Experiment S-009. Dwg. No. 681302, Naval Research Laboratory, Washington, D.C., October 27, 1970.
20. Detector Package Pan, Experiment S-009. Dwg. No. 681371, Naval Research Laboratory, Washington, D.C., October 27, 1970.
21. Gear Housing, Experiment S-009. Dwg. No. 681306, Naval Research Laboratory, Washington, D.C., November 4, 1970.
22. Interconnection Diagram, Experiment S-009. Dwg. No. 681350, Naval Research Laboratory, Washington, D.C., October 28, 1970.
23. Schematic and Logic Diagram, Experiment S-009. Dwg. No. 681351, Naval Research Laboratory, Washington, D.C., October 28, 1970.
24. Memorandum PM-SL-DP (339-71). Marshall Space Flight Center, Huntsville, Alabama, July 8, 1971.
25. Memorandum S&E-ASTN-SMH (71-58). Marshall Space Flight Center, Huntsville, Alabama, June 30, 1971.

REFERENCES (Concluded)

26. Experiment S-009 Nuclear Emulsion/MDA Electrical Interface Control Document. 40M35652, Marshall Space Flight Center, Huntsville, Alabama, May 4, 1970.
27. Skylab Preliminary Reference Trajectory. MSC Internal Note No. 70-FM-151, Manned Spacecraft Center, Houston, Texas, October 13, 1970.
28. Latch, Experiment S-009. Dwg. No. 68132, Naval Research Laboratory, Washington, D.C., October 27, 1970.
29. Top Assembly Nuclear Emulsion, Experiment S-009. Dwg. No. 681301, Naval Research Laboratory, May 11, 1970.
30. Skylab Program Directive No. 43B (Draft). NASA Office of Manned Space Flight, Washington, D.C., February 14, 1972.
31. Skylab Experiments Systems Handbook. Manned Spacecraft Center, Houston, Texas, October 29, 1971.
32. S&E-ASTN's Instrumentation Requirements, Skylab MDA. Internal Note S&E-ASTN-SD, April 29, 1971.
33. Multiple Docking Adapter, Instrumentation Program and Components List, 82000005600. Martin Marietta Corporation, June 23, 1970, Rev. to February 12, 1971.
34. Airlock Instrumentation Program and Components List, 61J880002, McDonnell Douglas Astronautics Company - Eastern Division, St. Louis, Missouri, May 1, 1970, Rev. to February 2, 1971.
35. Wilcoxson, C. B., et al: Mission Operations Design Support, Volume III. - OWS Experiments Malfunction Analyses, Rev. A, ED-2002-1244, Martin Marietta Corporation, Denver, Colorado, May 12, 1972.