

# CASE FILE COPY

**NASA CONTRACTOR  
REPORT**

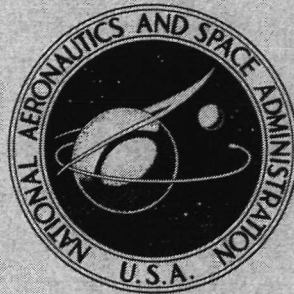

**NASA CR-1996**

**NASA CR-1996**

## **PRELIMINARY DESIGN OF AN AUXILIARY POWER UNIT FOR THE SPACE SHUTTLE**

**Volume IV — Selected System Supporting Studies**

*by M. L. Hamilton and W. L. Burriss*

*Prepared by*

**AIRESEARCH MANUFACTURING COMPANY**

Los Angeles, Calif.

*for Lewis Research Center*

**NATIONAL AERONAUTICS AND SPACE ADMINISTRATION • WASHINGTON, D. C. • APRIL 1972**

1. Report No. <b>CR-1996</b>	2. Government Accession No.	3. Recipient's Catalog No.	
4. Title and Subtitle <b>PRELIMINARY DESIGN OF AN AUXILIARY POWER UNIT FOR THE SPACE SHUTTLE. VOLUME IV - SELECTED SYSTEM SUPPORTING STUDIES</b>		5. Report Date <b>April 1972</b>	
		6. Performing Organization Code	
7. Author(s) <b>M. L. Hamilton and W. L. Burriss</b>		8. Performing Organization Report No. <b>71-7300-3.2</b>	
		10. Work Unit No.	
9. Performing Organization Name and Address <b>AiResearch Manufacturing Company Los Angeles, California</b>		11. Contract or Grant No. <b>NAS3-14408</b>	
		13. Type of Report and Period Covered <b>Contractor Report</b>	
12. Sponsoring Agency Name and Address <b>National Aeronautics and Space Administration Washington, D. C. 20546</b>		14. Sponsoring Agency Code	
15. Supplementary Notes <b>Project Manager, Joseph P. Joyce, Power Systems Division, NASA Lewis Research Center, Cleveland, Ohio</b>			
16. Abstract <p>This study has considered numerous candidate APU concepts, each meeting the Space Shuttle APU problem statement. Evaluation of these concepts indicates that the optimum concept is a hydrogen-oxygen APU incorporating a recuperator to utilize the exhaust energy and using the cycle hydrogen flow as a means of cooling the component heat loads. The initial portion of the study (Phase I) was concerned with evaluation of the candidate concepts; this information is presented in Volume II. The Phase II work accomplished preliminary design of the selected APU concept, placing primary emphasis on the cycle thermal management and the controls (to maintain desired turbine inlet temperature and rotational speed). The Phase II work is presented in Volumes III, IV, and V. Volumes III, IV, and V also present results for both steady-state and transient APU performance, based on digital computer programs developed during the study. The selected APU provides up to 400 hp out of the gearbox, has a fixed weight of about 277 lb, and requires about 2 lb/shp-hr of propellants.</p>			
17. Key Words (Suggested by Author(s)) <b>Auxiliary power unit (APU) Hydrogen-oxygen propellants Recuperated cycle</b>		18. Distribution Statement <b>Unclassified - unlimited</b>	
19. Security Classif. (of this report) <b>Unclassified</b>	20. Security Classif. (of this page) <b>Unclassified</b>	21. No. of Pages <b>129</b>	22. Price* <b>\$3.00</b>

\*For sale by the National Technical Information Service, Springfield, Virginia 22151

## FOREWORD

This report is the fourth volume of a series that comprises the following:

- Volume I - Summary
- Volume II - Component and System Configuration Screening Analysis
- Volume III - Details of System Analysis, Engineering, and Design for Selected System
- Volume IV - Selected System Supporting Studies
- Volume V - Selected System Cycle Performance Data

Volume II summarizes the Phase I portion of the program, in which the various component and system concepts were compared and evaluated. Volumes III, IV, and V contain the Phase II work, in which preliminary design of the selected APU system concept was performed.

**Page Intentionally Left Blank**

## CONTENTS

<u>Section</u>		<u>Page</u>
1	INTRODUCTION AND SUMMARY	1
	Introduction	1
	Summary	1
2	THERMAL MANAGEMENT	4
	Introduction	4
	Thermal Management Design Constraints	4
	Optimization of Lube and Hydraulic Oil Cooler Locations	16
	Oil Cooler Inlet Temperature Control	20
	Conclusions	25
3	TURBINE SPEED CONTROL	26
	Selection of Turbine Speed Control Concept	26
	Speed Control Requirements	26
	Description of Turbine Speed Control Concepts Considered	28
	Pressure-Modulated Performance	28
	Pulse-Modulated Performance	30
	Mission Performance Comparison: Pressure Modulation vs Pulse Modulation	33
	Sensitivity of Control Concept to System Interface Conditions	34
	Interaction between Control Concept and Other APU Components	35
	Technology Status	37
4	TURBINE INLET TEMPERATURE CONTROL	39
	Introduction	39
	Temperature Sensors	39
	Turbine Inlet Temperature Control Concepts	41
	Conclusions	50

## CONTENTS (Continued)

<u>Section</u>		<u>Page</u>
5	HYDROGEN LOOP TEMPERATURE CONTROL	53
	Introduction	53
	Hydrogen Loop Arrangements	54
	Recycle Flow Control	57
	Conclusions	63
6	HYDRAULIC THERMAL CONTROL	65
	Introduction	65
	Steady-State Performance	65
	Transient-State Performance	68
	Conclusions	78
7	FLUID DYNAMIC STUDIES	79
	Introduction	79
	Dynamic Flow Model	79
	Analog Results	79
	Conclusions	111
8	RELIABILITY	114
	Introduction	114
	System Reliability Evaluation	117

## SECTION I

### INTRODUCTION AND SUMMARY

#### INTRODUCTION

The Phase II work performed under Contract NAS3-14408, "Preliminary Design of an Auxiliary Power Unit (APU) for the Space Shuttle," was primarily concerned with detail system analysis, engineering, and design of an APU system concept selected during Phase I. The Phase II work is reported in three volumes:

Volume III Details of System Analysis, Engineering, and Design for Selected System

Volume IV Selected System Supporting Studies

Volume V Selected System Cycle Performance Data

Volume IV describes the studies performed during Phase II that were in support of the design activities and more detailed system definition. These included evaluations of alternative concepts of thermal management, speed control, turbine inlet temperature control, and hydrogen loop temperature control. Also included are results of studies concerning hydraulic system cooling, control system dynamics, and reliability. The control system studies involved analog simulation to determine the type of control system and its design characteristics to provide the stability and response required. Results of the more detailed digital transient-state program analysis are described in Volume III.

#### SUMMARY

Following are abstracts summarizing the contents of each section of this volume:

##### Section 2. Thermal Management

Section 2 discusses the design constraints for thermal management in terms of design temperature limits for heat exchangers and temperature levels obtained in the cycles. Consideration is given to the problems of absorbing the internally generated waste heat at acceptable temperature levels for the various heat loads. The general performance characteristics and limitations of possible thermal management concepts are then reviewed. It is shown that the APU cooling capacity under some conditions is less than the lube and hydraulic heat loads. Because of its small thermal inertia and its complete dependence on the APU for cooling, the lube heat load must be given cooling priority. Thus the lube cooler must be placed upstream of the hydraulic oil cooler. Section 6 presents further details of the APU cooling capacity.

##### Section 3. Turbine Speed Control

Section 3 compares the performance and operational characteristics of turbine speed control systems using pressure- and pulse-modulation techniques.

Pulse modulation is found to have a slightly lower propellant consumption. However, relatively little difference is found between total system weights for pressure- and pulse-modulation concepts, because of the higher component fixed weight for pulse modulation. Pressure modulation is selected for the baseline concept as offering lower development risk and greater operational flexibility in meeting close speed control and critical electrical power quality requirements.

#### Section 4. Turbine Inlet Temperature Control

Various methods of directly and indirectly controlling turbine inlet temperature are described and compared in Section 4. The baseline approach uses a thermocouple to sense turbine interstage temperature and trim oxygen flow to maintain turbine inlet temperature constant. The requirements for the temperature sensor are within the present state of the art and no development risk in this area is anticipated.

#### Section 5. Hydrogen Loop Temperature Control

Two types of hydrogen loop are compared. One of these (the baseline approach) has the recuperator downstream from the oil coolers and uses a recycle loop to preheat the inlet hydrogen. The other has the recuperator upstream from the oil coolers and uses bypass control to maintain constant outlet hydrogen temperature. The baseline approach is selected to eliminate low temperature problems in the heat exchangers. Performance of the baseline system with and without the recycle flow control is described. It is shown that a recycle flow control valve is not required where the inlet hydrogen temperature to the system remains relatively constant.

#### Section 6. Hydraulic Thermal Control

This section considers the effect of hydraulic fluid temperature on APU system performance and hydraulic heat sink capacity. At minimum APU output, the hydrogen heat sink capacity will not be adequate to absorb the waste heat generated by the hydraulic pump, and hydraulic fluid temperature will increase with time at minimum load. Conversely, excess cooling capacity will be available at high APU output and hydraulic fluid temperature will drop. Variation in hydraulic fluid temperature with time is analyzed for the most severe Space Shuttle vehicle condition (4000 sec at 10 hydraulic hp output for the Orbiter vehicle). System thermal capacity will be adequate to avoid excessive temperature rise for certain combinations of inlet hydrogen temperature and initial hydraulic fluid temperature. It is concluded that the system must be arranged to give priority to lubricant cooling and the lubricant cooler should be upstream in the hydrogen circuit from the hydraulic cooler, thus providing low lube oil temperature under all operating conditions.

#### Section 7. Fluid Dynamic Studies

Fluid dynamic evaluation of the APU by using an analog computer is described in this section. The subsystem model included the volumes, pressure drops, and other pertinent component characteristics. Input variables included the reactant supply pressure, and a variety of turbine power load schedules. While exercising the system inputs, control concepts were developed and

compared to determine stability of turbine speed control, valve position, and reactant flow and pressure. The result of these studies was the selection of an integrating flow control concept, and a definition of the characteristics of this control concept. Operation of the APU through turbine load schedules, which included spike loads and simulated startup conditions, verified the suitability of the selected concept for the application.

## Section 8. Reliability

Reliability studies were conducted at system and component levels. System level studies defined instrumentation requirements for operational monitoring of system status, ground checkout, and fault detection for subsystem shutdown. The individual components were analyzed to determine potential failure modes. Results of the component analysis indicate that the component designs lead to fail-safe APU operation.

## SECTION 2

### THERMAL MANAGEMENT

#### INTRODUCTION

The APU is required to dissipate its internally generated heat at acceptable temperature levels for proper operation of the APU components. Thermal control provisions are required for the gearbox lubricant (which cools the bearings, gears, and alternator) and the hydraulic fluid (which cools the hydraulic pump). The lubricant heat load varies with output power, as shown in Figure 2-1. The hydraulic heat load is assumed to be constant (for operation at a given discharge pressure) and equal to the pump losses. The primary heat sink for dissipation of the internally generated heat is the hydrogen flow into the APU system required for power generation. The hydrogen flow varies with APU output and ambient pressure, as shown in Figure 2-2 for representative conditions; it is also dependent to a lesser degree upon cycle configuration, hydrogen inlet temperature, etc. In actuality, these other factors impact primarily on oxygen consumption, which for purposes of a thermal management discussion, does not represent an important heat sink. Cooling capacity may be marginal for the APU internal heat loads under the minimum propellant flow conditions obtained at low output power and low ambient pressure. Dissipation of the hydraulic and lubricant heat loads involves considerations of upper and lower temperature limits, which will significantly influence APU cycle configuration.

#### THERMAL MANAGEMENT DESIGN CONSTRAINTS

From an APU thermal management standpoint, the cycle consists of the following three functional elements:

Equipment heat loads in the form of two heat exchangers, one for cooling the gearbox lubricant, the other for cooling the hydraulic fluid

Turbine exhaust gas recuperator, which is used to preheat the hydrogen entering the system

Turbine-combustor, which generates useful output power from the system

Since the recuperator uses turbine exhaust gas, there are two possible basic arrangements of these three functional elements, as shown in Figure 2-3. The first, the approach selected for the baseline, places the recuperator downstream from the equipment (oil cooler) heat loads. The alternative approach places the recuperator upstream from the oil coolers. Each of these functional elements has design temperature limits that must be observed for proper system operation.

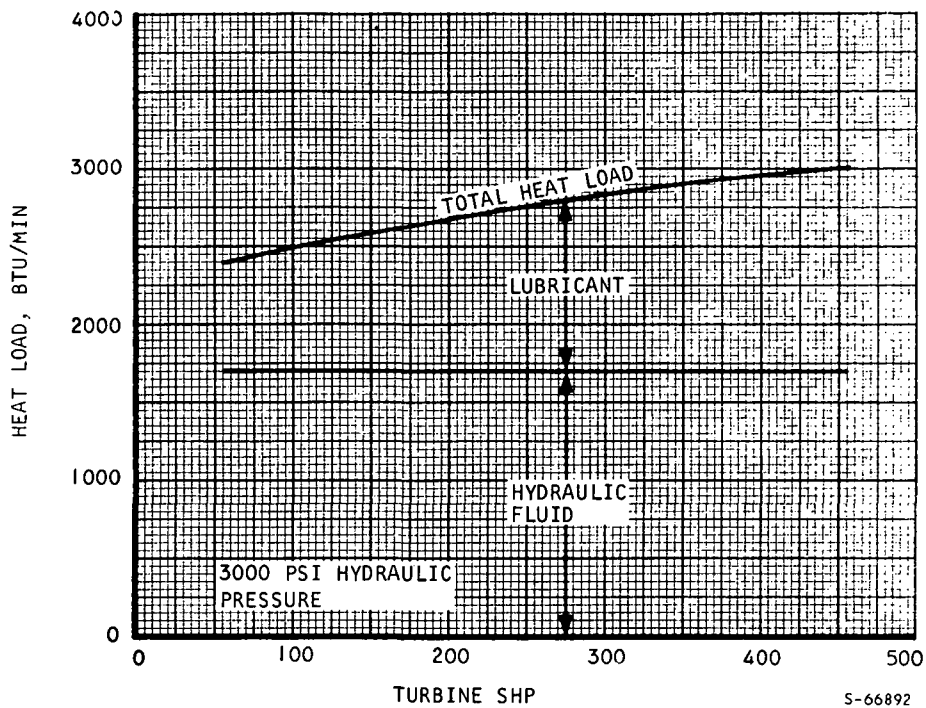

Figure 2-1. Assumed APU Internal Heat Loads

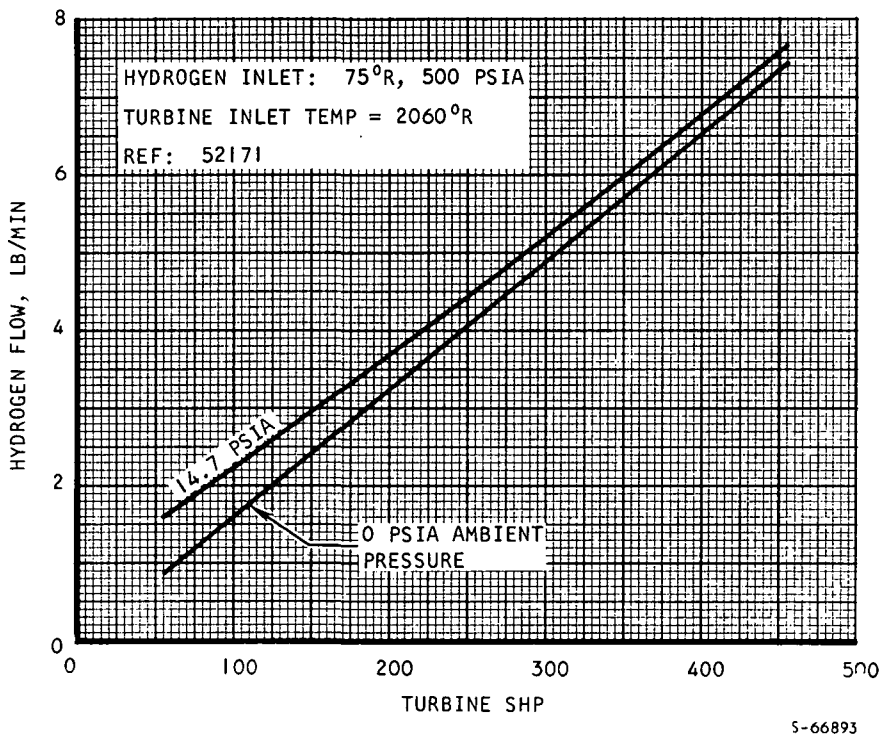

Figure 2-2. Typical Hydrogen Flow Characteristics

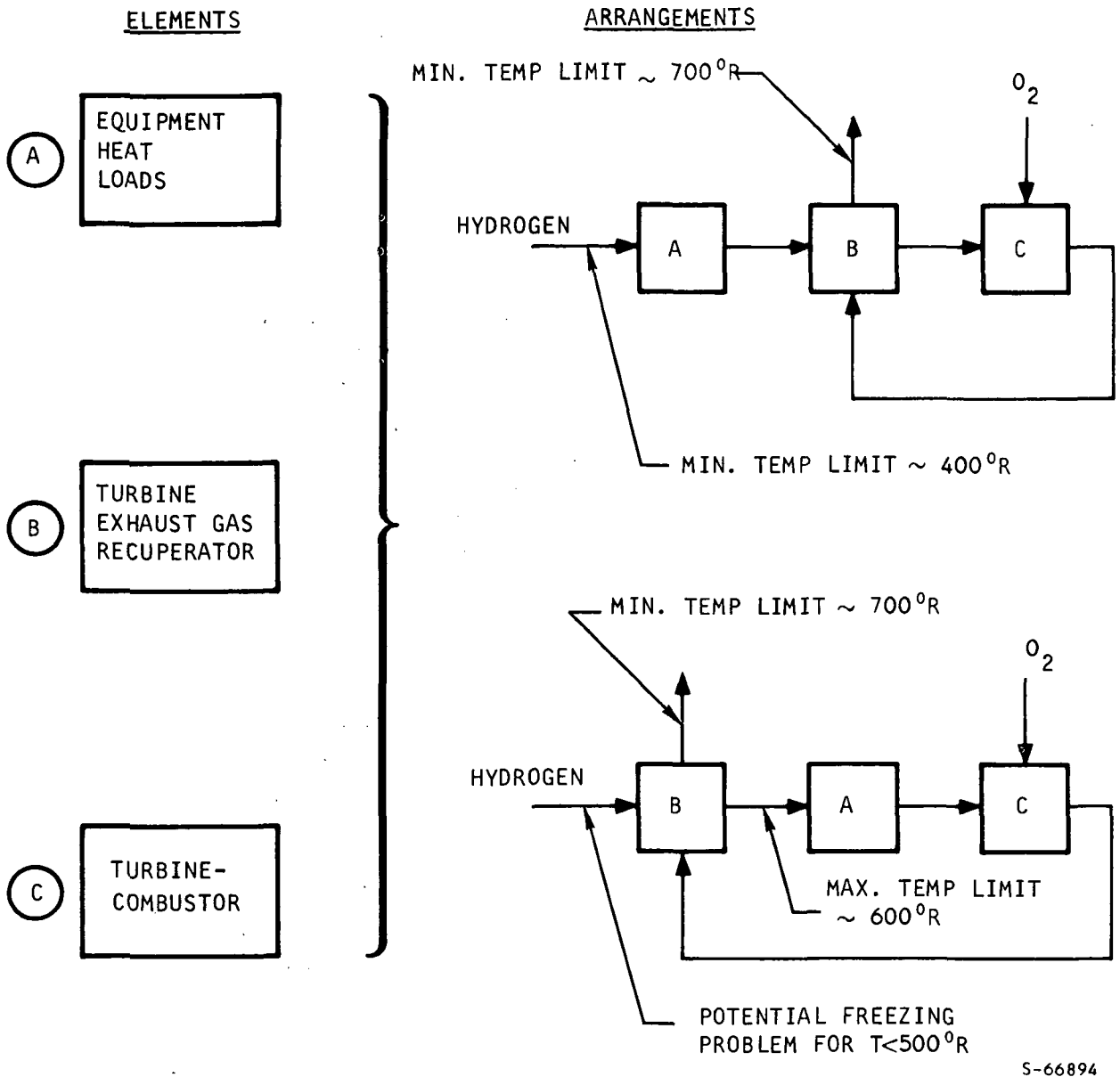

Figure 2-3. APU Cycle Thermal Management Functional Elements and Possible Arrangements

## Oil Cooler Temperature Limits

The hydraulic fluid has NASA-specified operating temperature ranges from 530<sup>o</sup>R to 750<sup>o</sup>R, and the lube oil maximum temperature must also be less than 750<sup>o</sup>R. As a consequence, the maximum temperature to which the hydrogen can be heated in the oil coolers is on the order of 740<sup>o</sup>R. The minimum hydrogen inlet temperature to the oil coolers is determined by the temperature at which the lubricant congeals or the hydraulic fluid discharge temperature drops below 530<sup>o</sup>R. Because congealing occurs well below 530<sup>o</sup>R, there is substantial incentive to place the lube oil cooler upstream of the hydraulic oil cooler, thus minimizing the effective hydrogen heat sink capacity.

In the AiResearch studies concerning this problem, a 42-node thermal analyzer program was used. The simplified model shown in Figure 2-4 will be used to illustrate the results of these studies.

### 1. Wall Temperature Criterion

Heat exchanger wall temperature is the controlling parameter here. If the wall temperature is too low, viscosity of the oil will increase near the wall, thereby restricting flow, reducing heat transfer, and further reducing wall temperature. The result is congealing of fluid within the heat exchanger. Extensive AiResearch experience with oil coolers indicates the wall temperature must be maintained above 440<sup>o</sup>R at all points within the heat exchanger (a local cold spot will tend to propagate and result in freezing on the side). To maintain the wall temperature as high as possible, extended surface can be used on the hot (oil) side as shown in Figure 2-4, the cold (hydrogen) side has prime surface only. It is therefore desired to maximize the ratio

$$\frac{(\eta hA)_O}{(hA)_H}$$

where the subscript O refers to the oil side, the subscript H refers to the hydrogen side, and the inclusion of the heat transfer surface effectiveness  $\eta$  reflects use of extended surface on the oil side. However, a basic limitation occurring in maximizing this ratio is the problem of accurately calculating heat transfer coefficients for operation over extreme temperature differences or in temperature ranges where great changes in viscosity and other fluid properties occur. A minimum inlet hydrogen temperature of 400<sup>o</sup>R has been chosen for oil coolers using conventional heat exchanger design. Based upon directly-applicable experience in this area, this design limit reduces development risk. As will be discussed subsequently, lower inlet temperatures can be accommodated through use of unconventional heat exchanger designs with significantly higher development risk and definite fabrication problems.

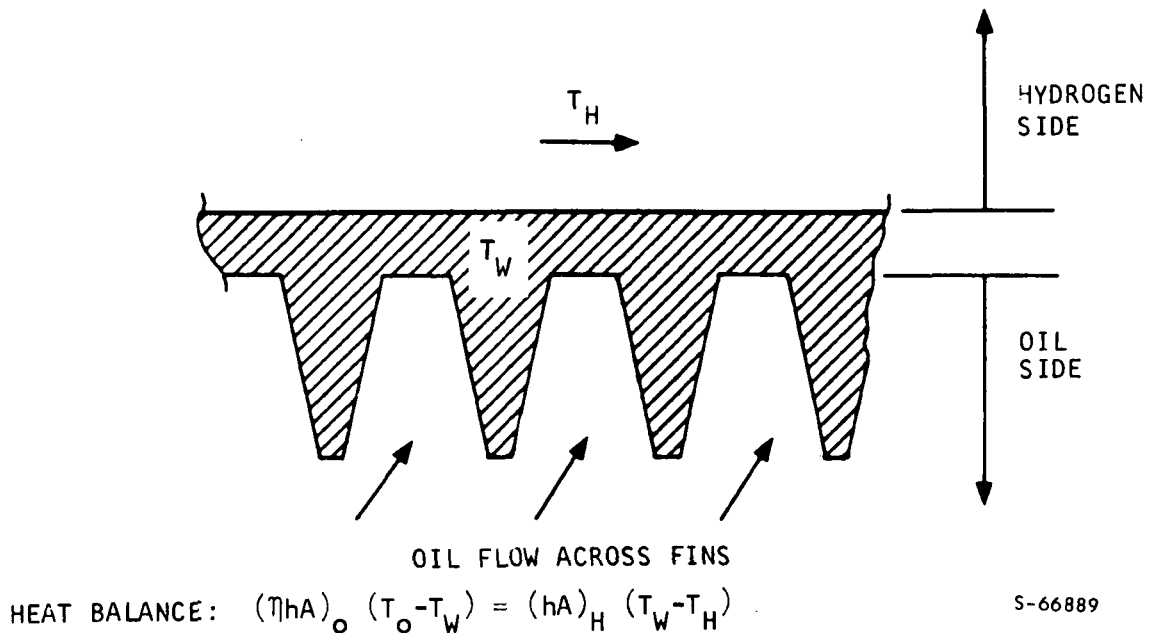
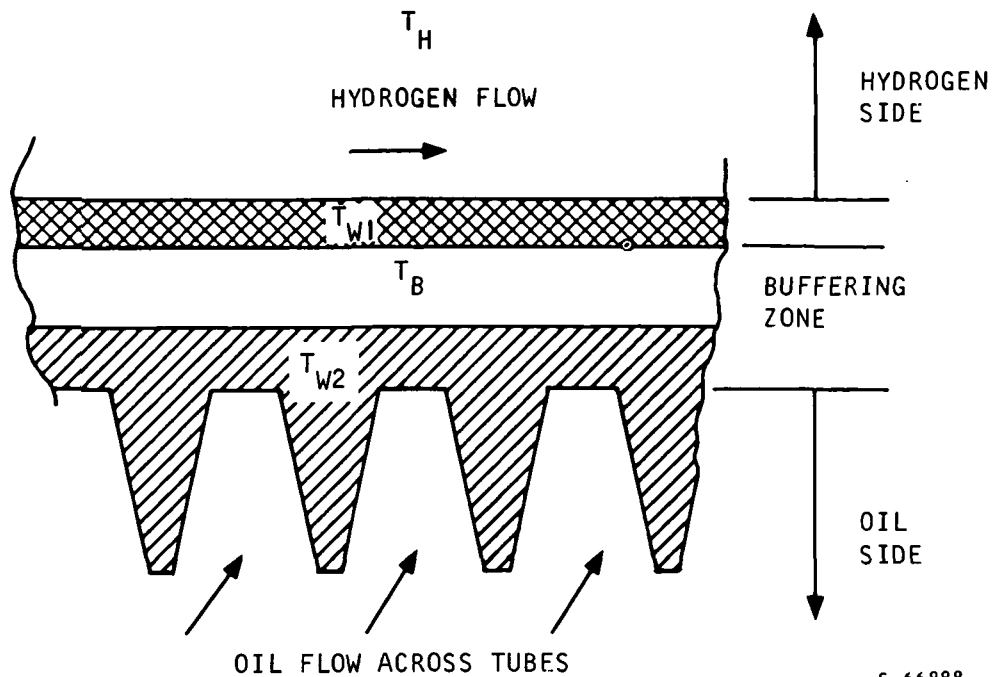

Figure 2-4. Simplified Heat Transfer Model for Low-Temperature Problem Discussion

## 2. Buffered Design to Increase Wall Temperature

Addition of thermal resistance in the heat transfer path allows a reduction in hydrogen inlet temperature. For example, if the heat exchanger is buffered as shown schematically in Figure 2-5, it may be feasible to allow hydrogen inlet temperature as low as 200°R while maintaining calculated wall temperature at acceptable levels. This approach is not recommended since it is more complex, difficult to fabricate, heavier, and is incapable of providing the necessary cooling over the range of hydrogen temperature. AiResearch has designed and tested complex buffered heat exchangers of the plate-fin type where this type of design is important to system safety. That is, buffered heat exchangers have been used in applications such as aircraft environmental control systems that use fuel as the heat sink to cool hot engine bleed air. These systems used a buffering fluid that was continuously purged. A buffered tubular heat exchanger would be very difficult to fabricate to maintain the low leakage levels required of the heat exchangers for the present application. All of these factors mitigate against use of buffered heat exchangers for the Space Shuttle APU. Furthermore, the 400°R low-temperature limitation of a conventional design can be accommodated and it is not necessary to solve the problems associated with use of buffered heat exchangers in this application.



S-66888

HEAT BALANCE:  $(hA)_H (T_{W1} - T_H) = (hA)_B (T_B - T_{W1}) =$   
 $(hA)_B (T_{W2} - T_B) = (\eta hA)_O (T_O - T_{W2})$

Figure 2-5. Simplified Heat Transfer Model for Buffered Heat Exchanger

### 3. Flow Instability

Freezing has long been a troublesome problem in many heat exchangers designed to cool liquids. Freezing or congealing has occurred in many instances when the cold fluid was below the freezing point of the fluid being cooled, even though the conventional heat transfer calculations showed the wall temperature to be above the freezing point. Such freezing is often the result of a flow instability caused by the large variation of viscosity with temperature. While flow instability is known to be common in two-phase (boiling or condensing) flow it is, unfortunately, not always considered in single-phase flow. Flow instability leads to decreased performance even when freezing cannot occur.

The standard method of determining whether freezing can occur is to calculate a minimum wall temperature from the minimum fluid temperatures and the ratio of  $hA_{HOT}/hA_{COLD}$ . If the calculated wall temperature is above the freezing or congealing temperature of the liquid being cooled, freezing is not expected to occur. Freezing (or congealing) often does occur, however,

under these circumstances, Figure 2-6 shows unstable flow in a heat exchanger designed by the wall temperature criterion for use with 40°F hydrogen inlet temperature.

The instability problem is analogous to that occurring in forced-convection vaporization. In both cases, there is negative slope of pressure drop vs flow rate. In boiling, it is due to the phase change and the increased pressure drop with vapor over that with liquid at a higher flow rate. In liquid cooling, it is due to the increased viscosity of liquid with decreasing temperature. The negative slope of the pressure drop flow rate curve is a classical cause of flow instability.

It should be noted that flow instability occurs only in the heat transfer environment. In cases where instability can occur, so called steady-state conditions are actually transient and must be treated accordingly. The better approach, of course, is to manipulate the design and or the fluids and temperatures to avoid the unstable, steady-state condition.

The factors associated with flow stability are as follows:

Factors Leading to Freezing and Instability	Factors Favoring Stable Operation
Laminar flow  High change in liquid viscosity (in the heat transfer environment)  Multiple flow channels  Pump flow strongly dependent on $\Delta P$	Turbulent flow  Low change in liquid viscosity  Single flow channel  Constant displacement pump

With the hydraulic heat exchanger, the first three factors may be highly unfavorable. First, varying of hydraulic flow with output power and laminar flow will certainly occur during a portion of APU operation, at low power levels, where low minimum hydrogen inlet temperatures to the hydraulic cooler may be obtained to meet the hydraulic heat load requirements. Second, as shown in Figure 2-7, the hydraulic fluid undergoes great changes in viscosity at low temperatures. Third, to minimize heat exchanger size and pressure drop, it almost certainly will use multiple flow channels, probably in the form of a large number of parallel tubes. Only the fourth factor involving use of a positive-displacement pump is favorable to the hydraulic heat exchanger. It can be concluded from this that the hydraulic heat exchanger is highly susceptible to flow instability unless the hydrogen inlet temperature is maintained at a sufficiently high level to avoid possibility of large changes in fluid viscosity.

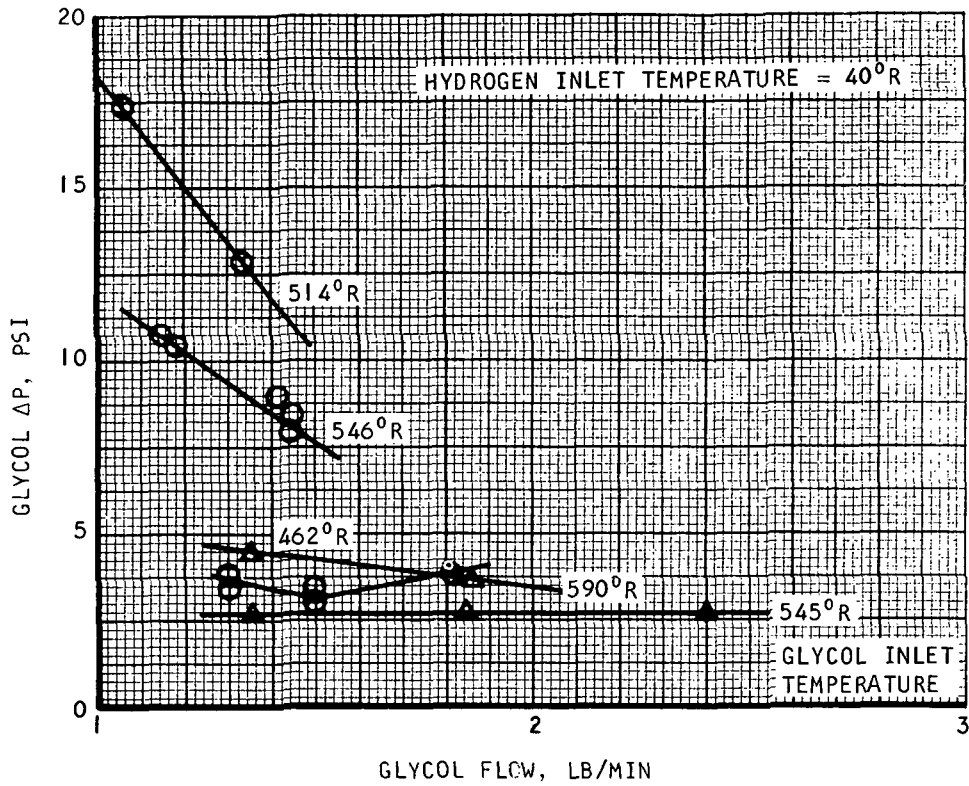

Figure 2-6. Test Data Showing Unstable Flow in Heat Exchanger Designed by Wall Temperature Criterion

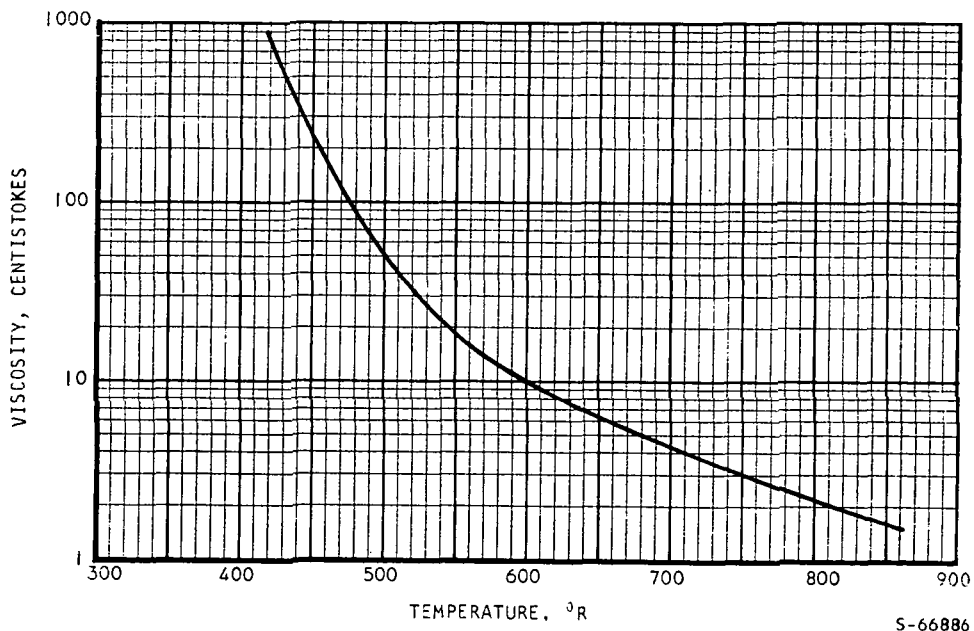

Figure 2-7. Hydraulic Fluid Viscosity

#### 4. Flow Distribution

To a considerable extent, the problems of maintaining suitable heat exchanger wall temperature and insuring flow stability under all operating conditions are related to the problem of flow distribution. In other words, appropriate solution of these problems requires heat exchanger designs with careful attention given to flow distribution. Typically, a counterflow or parallel-flow shell-and-tube heat exchanger design is provided with such features (illustrated in Figure 2-8) as:

Internal baffles with multiple-pass crossflow outside tubes  
(this insures proper flow distribution outside tubes and increases heat transfer coefficients)

Proper manifold design with appropriate transition sections for flow acceleration and deceleration

Guide vanes (particularly for low L/D transitions)

A pure parallel-flow or counterflow design with compact shell-and-tube core design may exhibit serious performance problems resulting from poor flow distribution, as illustrated schematically in Figure 2-9.

#### Recuperator Temperature Limits

Two important temperature limits are obtained in the recuperator. One of these involves the wall temperature of the heat exchanger. Turbine exhaust gas is a mixture of hydrogen and water vapor; it is undesirable for this water vapor to condense or freeze out on the heat exchanger wall. As a consequence, the recuperator wall temperature must be above the turbine exhaust gas dewpoint temperature at all points in the heat exchanger and under all operating conditions. As shown in Figure 2-10, the dewpoint temperature of the turbine gas varies with O/F ratio and ambient pressure. A second temperature limit involves the bulk temperature of the turbine exhaust gas at the recuperator outlet.

##### 1. Wall Temperature

It is undesirable for water vapor in the turbine exhaust to condense or freeze out on the heat exchanger wall. As a consequence, the recuperator wall temperature must be above the turbine exhaust gas dewpoint temperature at all points in the heat exchanger under all operating conditions. As shown in Figure 2-10, the dewpoint temperature of the turbine gas varies with O/F ratio and ambient pressure. Wall temperature can in theory be controlled by proper design with respect to hA ratio between the hot and cold sides. As before in the case of the oil coolers, this approach is questionable where large changes in viscosity or other fluid properties occur. In the case of low-temperature inlet hydrogen, the problem is compounded by the inability to accurately predict heat transfer coefficients on the hydrogen side. In the supercritical region, it is estimated that the heat transfer coefficients can be predicted to an approximate factor of four.

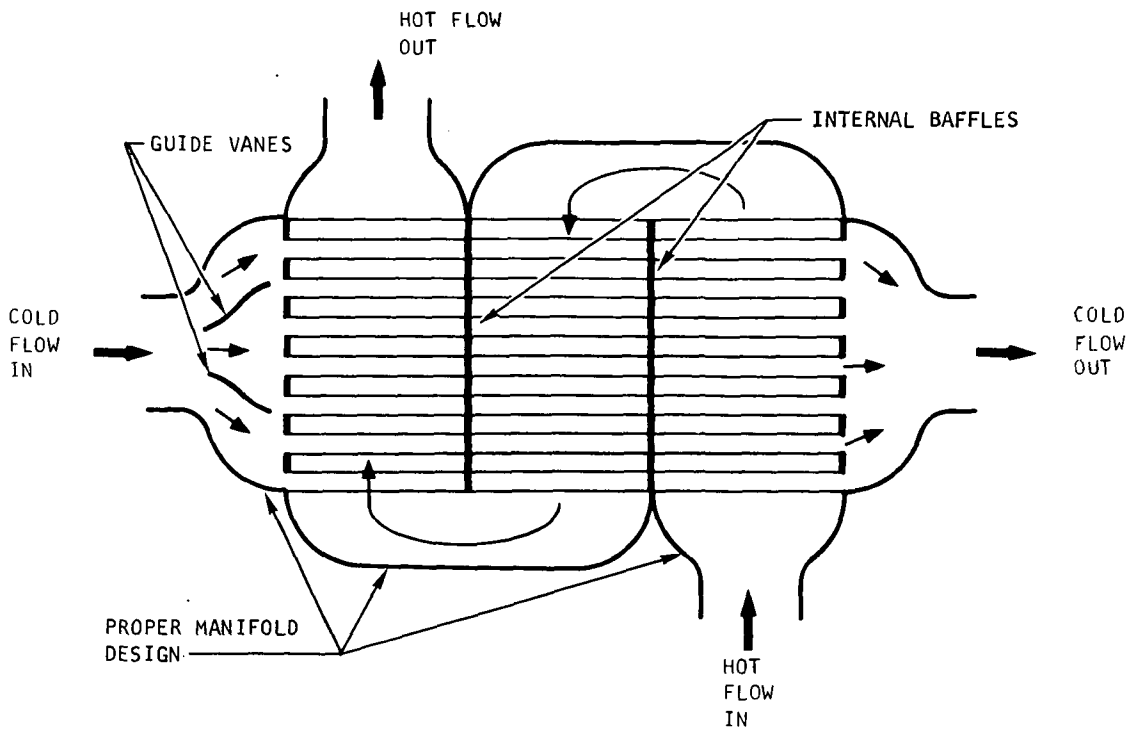
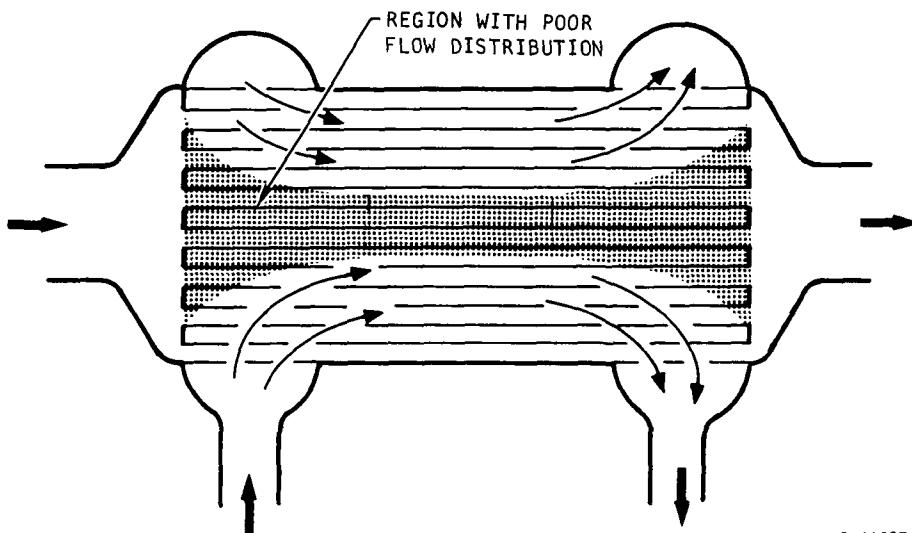

Figure 2-8. Typical Heat Exchanger Design Provisions for Good Flow Distribution



S-66897

Figure 2-9. Region of Poor Flow Distribution in Pure Parallel-Flow Design with Compact Tubular Surface

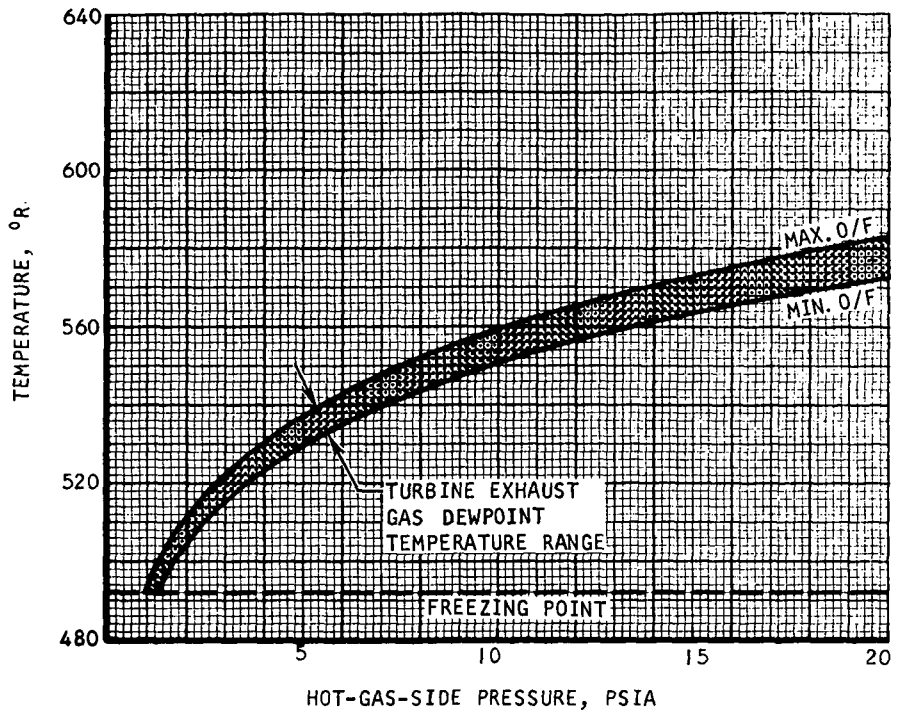

Figure 2-10. Recuperator Condensation Criteria

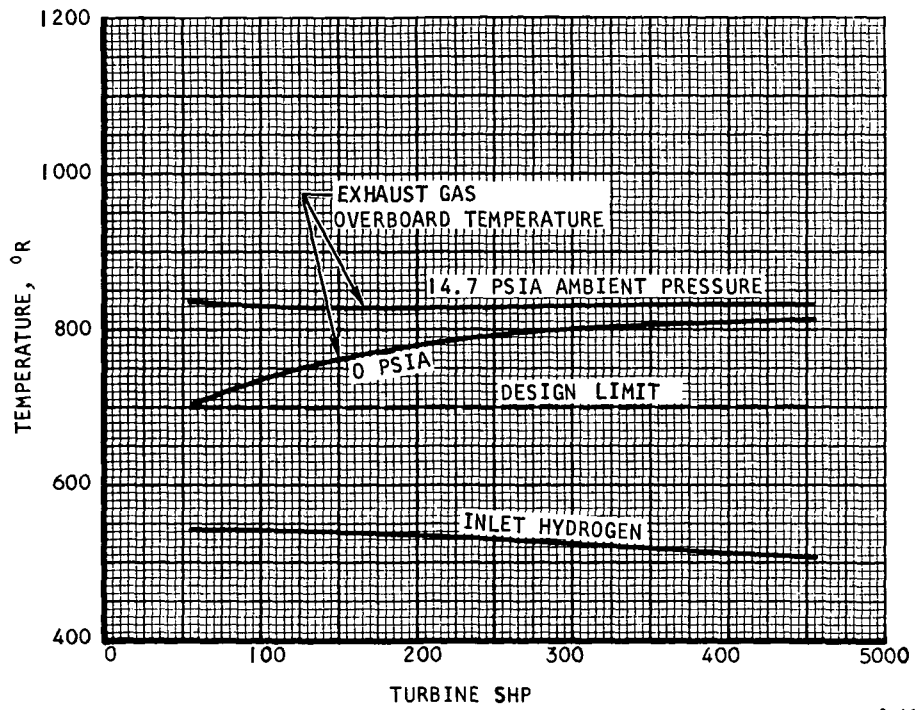

Figure 2-11. Typical Recuperator Performance

S-66896

Recuperator wall temperature can be maximized for a given set of operating conditions by use of a parallel-flow heat exchanger design. However, any design that depends upon accurate prediction of heat transfer coefficients and requires equal and stable flow in parallel tubes for supercritical inlet hydrogen can be considered to be a high-risk design that will require extensive analytical work and testing to insure adequate performance under all possible operating conditions.

## 2. Temperature Gradients

Some types of temperature gradients can be handled by use of straightforward design provisions such as expansion bellows, free floating headers, and tube curvature. In certain parts of the heat exchangers the temperature gradient problem is much more difficult. In the case of the recuperator for the present application, the braze joints between the tubes and headers can be expected to provide problems. During the transient condition at startup, there will be a significant temperature difference between the tube wall and the header plate in the vicinity of the braze joints, which can result in a low-cycle fatigue problem. This temperature gradient problem can be alleviated by:

- Reducing temperature differences by altering inlet conditions

- Using baffles on the hot-gas side to improve heat transfer and reduce temperature gradients

- Using heat exchanger designs and materials that are less susceptible to this problem

The specific provisions used to minimize these problems are discussed in Volume III for the various heat exchangers.

## 3. Bulk Temperature

If the bulk temperature of the turbine exhaust gas drops to an excessively low level in the recuperator, moisture condensation will occur, leading to potential freezing problems in the exhaust ducting. A lower bulk temperature limit of 700°R has been selected for the recuperator design. The recuperator is sized to provide a minimum turbine exhaust gas outlet temperature of 700°R under the most severe conditions (minimum power, 0 psia ambient pressure) where minimum hydrogen flow and maximum heat transfer effectiveness are obtained. Figure 2-11 shows the bulk outlet temperature as a function of turbine power output and ambient pressure, for a typical recuperator design in a complete APU system. Also shown is the hydrogen inlet temperature, which is maintained above 500°R by the thermal control provisions. Design of the system to provide relatively high inlet hydrogen temperatures to the recuperator will also significantly reduce the recuperator structural design problems resulting from temperature gradients in the heat exchanger. As will be shown, this can be readily accommodated in the cycle by appropriate placement of components.

## Turbine-Combustor Temperature Levels

Figure 2-12 shows the temperature levels obtained in the power generating end of the system as a function of turbine output power and ambient pressure. Oxygen is reacted with the hydrogen in the combustor to bring the turbine inlet temperature to a constant level of  $2060^{\circ}\text{R}$ . Because of the varying inlet hydrogen temperature to the combustor, the O/F ratio will vary with turbine power level and ambient pressure. (Alternative concepts that operate at constant O/F ratio are discussed in Section 4 of this volume.)

## OPTIMIZATION OF LUBE AND HYDRAULIC OIL COOLER LOCATIONS

Figure 2-13 shows the hydrogen discharge temperatures from the oil coolers as a function of turbine output power and inlet hydrogen temperature for the waste heat load given in Figure 2-1 and the hydrogen flow given in Figure 2-2. It will be noted that cooling capacity is inadequate within the prescribed upper temperature limit at minimum output power for even the minimum hydrogen inlet temperature (which violates the  $400^{\circ}\text{R}$  minimum inlet temperature limit). As the inlet hydrogen temperature is increased, the cooling inadequacy at low loads is increased. It may be feasible to allow inadequate cooling of the hydraulic system on a transient basis because of the large thermal inertia of that system (this subject is discussed in Section 6 of this volume.) However, it will be necessary to provide adequate cooling for the lubricant since no other heat sink is available for that purpose and since the lubricant thermal inertia is small. Therefore, any thermal management scheme must give priority to lubricant cooling. Thus, the recommended cooler arrangement is as shown in Figure 2-14 (which also shows the rejected concept).

Figure 2-13 is based upon an energy balance that uses the specified heat loads and hydrogen flow relationships. The outlet temperature from the hydraulic heat exchanger will be determined by the hydraulic fluid temperature, rather than by the hydraulic heat load, since it is the temperature differences that provide the heat transfer driving potential. Figure 2-15 shows typical hydrogen discharge temperatures from the hydraulic cooler as a function of turbine output power for hydraulic fluid temperatures of  $550^{\circ}$ ,  $650^{\circ}$ , and  $750^{\circ}\text{R}$ . It will be noted that the hydrogen temperature varies by approximately  $220^{\circ}\text{F}$  over this range. At high power output, the hydraulic fluid will be overcooled and the fluid temperature will drop with time. At low output, insufficient cooling capacity is available and fluid temperature will rise.

It can be concluded from Figure 2-15 that the hydrogen discharge temperature is primarily dependent upon the hydraulic fluid inlet temperature. Therefore, any APU system concept depending upon maintaining constant hydrogen temperature downstream of the oil coolers must have a bypass control on the hydrogen side. Depending upon the hydraulic power profile, the efficiency of the hydraulic system, and the thermal control provisions, it may also be necessary to install a bypass temperature control on the hydraulic side.

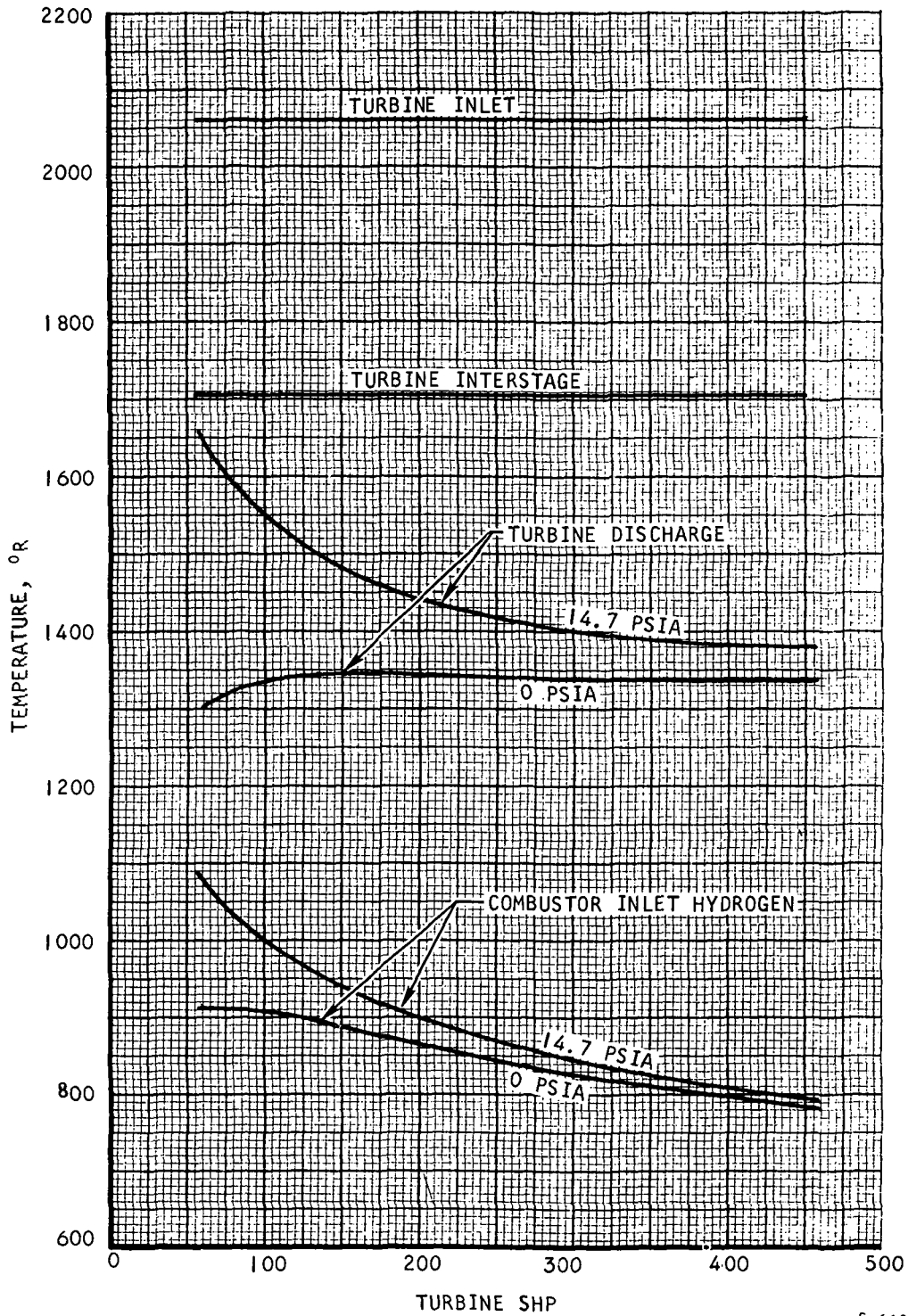

S-66891

Figure 2-12. Turbine-Combustor Temperature Levels

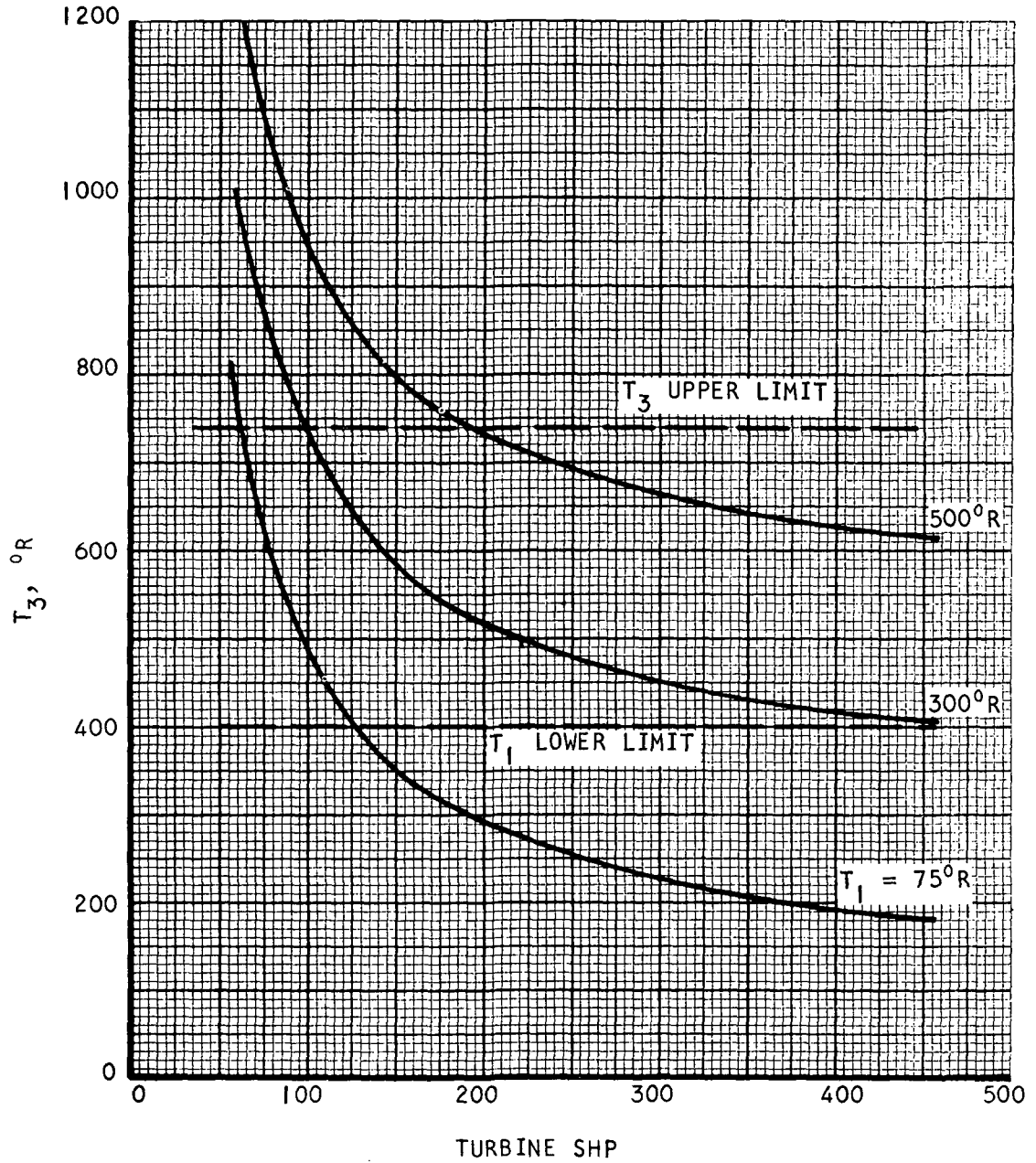
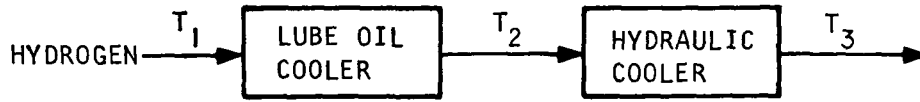

S-66890

Figure 2-13. Hydrogen Discharge Temperature vs Inlet Temperature and Turbine Output Power

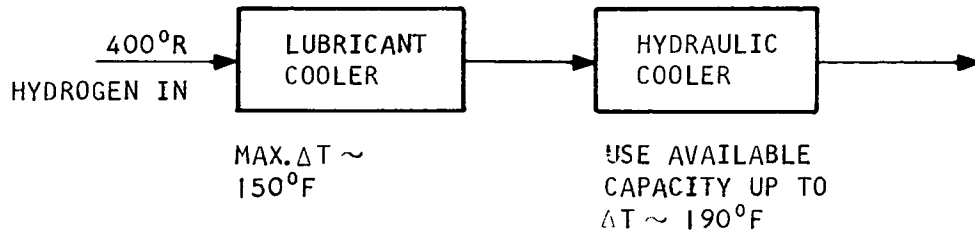

a. PROPOSED BASELINE APPROACH

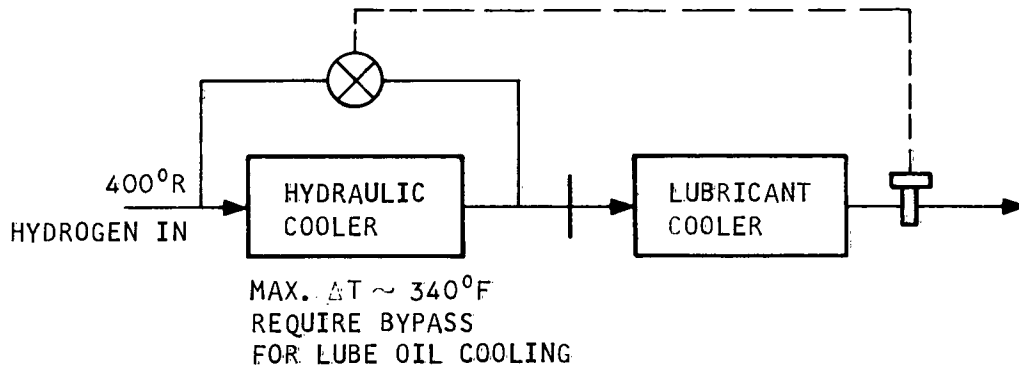

b. ALTERNATIVE, REJECTED ARRANGEMENT

Figure 2-14. Arrangement of Hydraulic and Lubricant Coolers

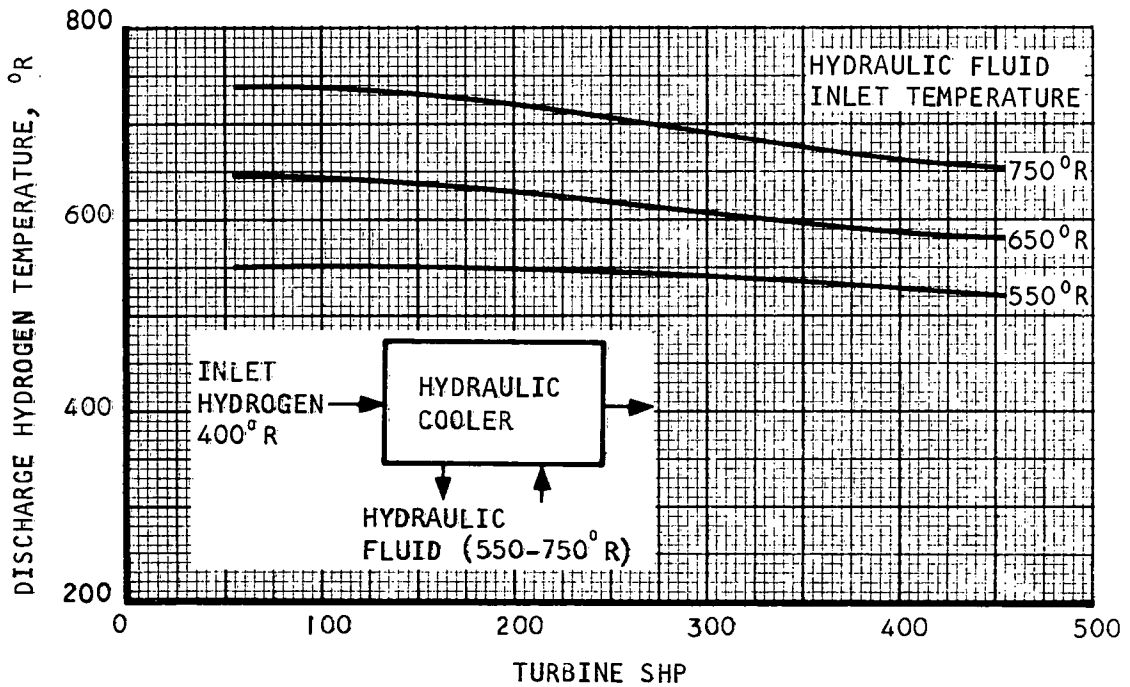

S-66912

Figure 2-15. Hydraulic Cooler Discharge Hydrogen Temperature Variation with Hydraulic Fluid Inlet Temperature

## OIL COOLER INLET TEMPERATURE CONTROL

As indicated previously by Figure 2-3, the recuperator can be located either downstream or upstream of the oil coolers. Thus, to control the hydrogen temperature into the oil coolers, a recycle flow can be used if the recuperator is downstream of the coolers, and a bypass control if the recuperator is upstream. The following material discusses each concept.

### Hydrogen Flow Recycling Downstream Recuperator

Recycling hydrogen flow through the heat exchangers reduces the  $\Delta T$  required for dissipation of a given heat load by increasing the mass flow. This does not increase the system heat sink capacity, but does serve to reduce the temperature difference required for heat rejection. This is illustrated by Figure 2-16, which shows that the inlet temperature to the oil coolers can be increased to  $400^{\circ}\text{R}$  by an 87.5 percent (0.79 lb/min) recycle flow. This approach solves the low hydrogen inlet temperature problem without reducing the heat sink capacity of the system (the discharge hydrogen temperature is determined by the heat loads and hydrogen throughflow, and therefore is independent of recycle flow rate). Lower recycle flow rates can be obtained by recycling flow after it passes through the recuperator.

The baseline concept uses recycle flow from the recuperator discharge to maintain the oil cooler inlet temperature at acceptable levels for the entire possible range of operating conditions, as shown in Figure 2-17. With this arrangement, the hydrogen inlet temperature to all of the heat exchangers is maintained within the desired temperature limits, which minimizes heat exchanger design problems and development risk. As discussed in Section 5, the recycle flow can be efficiently provided by a jet pump. It should be noted that a major advantage of the recycle concept is the temperature stability it provides during sudden inlet hydrogen temperature transients. Because the recycle temperature is relatively constant, the mixed flow temperature transient is much less than the inlet transient.

### Hydrogen Flow Bypassing (Upstream Recuperator)

The hydrogen flow to the oil coolers can be preheated in a recuperator located upstream from the oil coolers. With this arrangement, the recuperator bypass control maintains inlet temperature to the first oil cooler at  $400^{\circ}\text{R}$ . As shown in Figure 2-18, preheating the hydrogen in this way seriously reduces the heat sink capacity and insufficient cooling is available at turbine output power less than 130 shp. Supplemental cooling (representing 150 to 200 lb of water as an expendable evaporant) will be required for the prescribed Space Shuttle vehicle missions. Therefore, it is concluded that this concept is not competitive with the hydrogen recycle concept previously discussed.

If the recuperator bypass control is used to maintain downstream temperature constant (as shown in Figure 2-19), cooling capacity is not reduced at part load. However, over most of the APU operating range, the inlet temperature to the first oil cooler will be below  $400^{\circ}\text{R}$ . This is considered to be

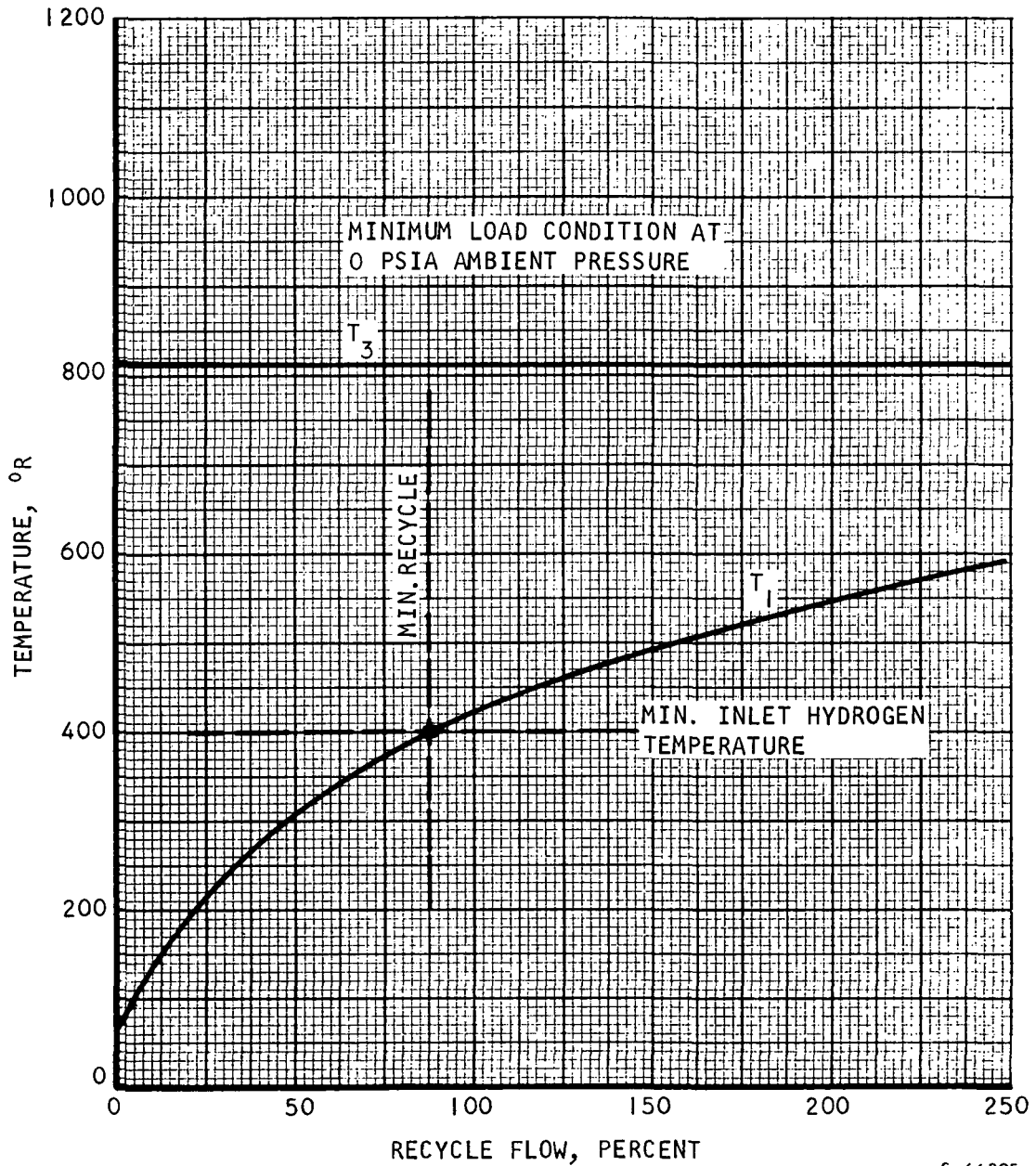
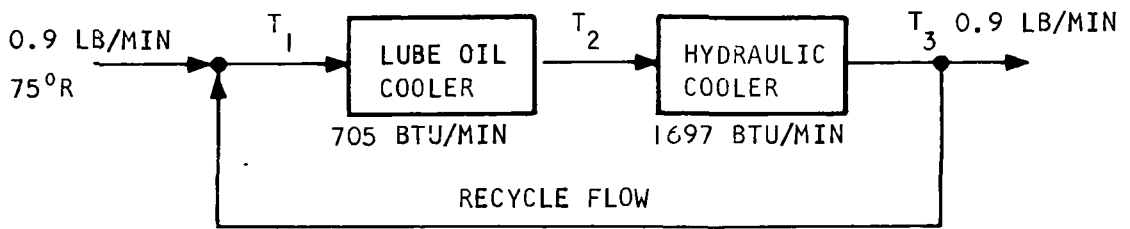
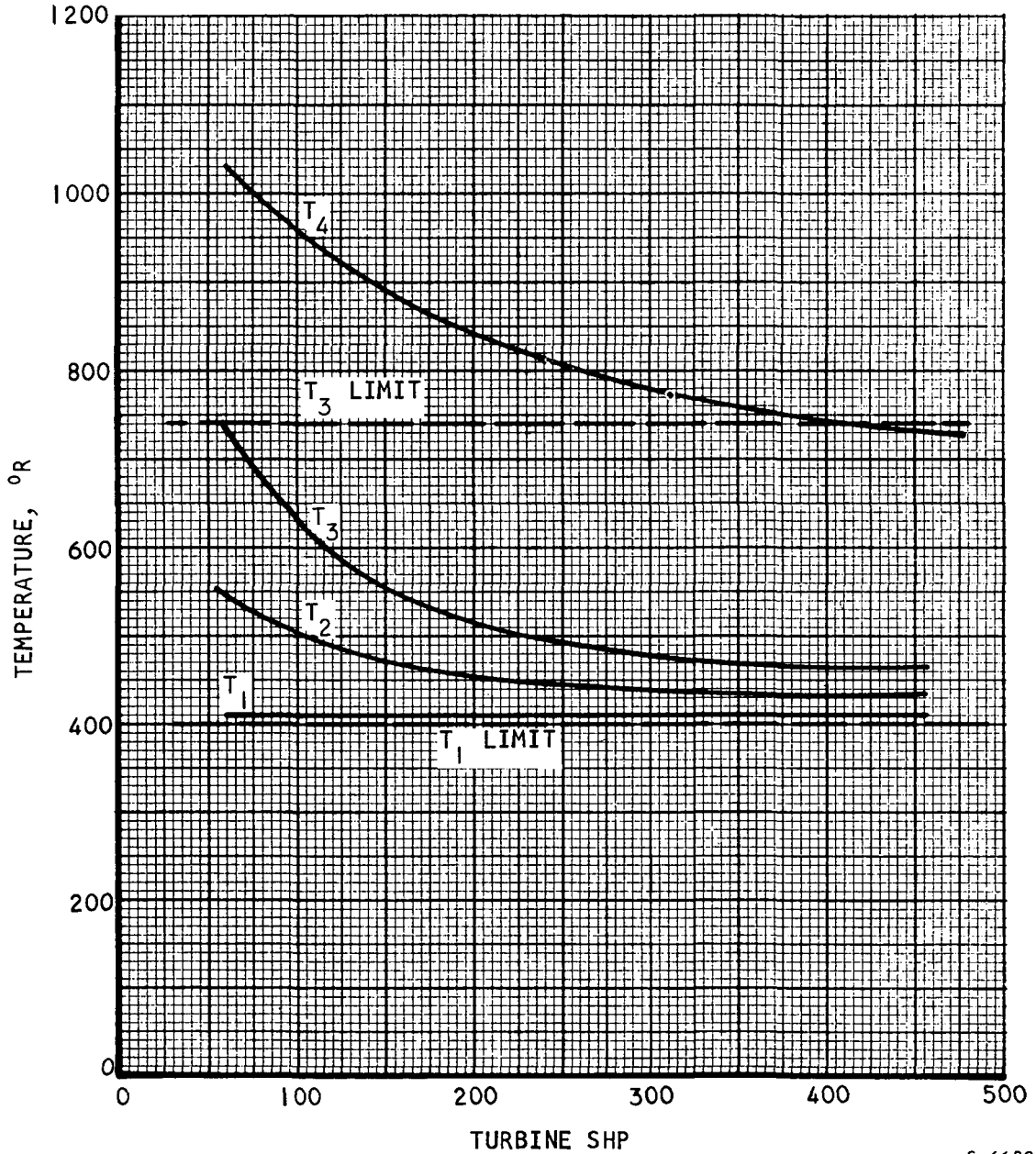
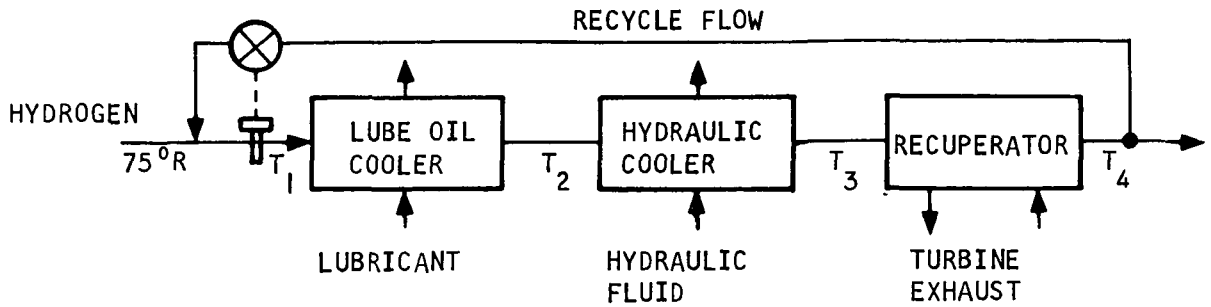

Figure 2-16. Elimination of Low Hydrogen Inlet Temperature Problem by Means of Hydrogen Recycle



S-66898

Figure 2-17. Typical Hydrogen Recycle System Temperature Levels

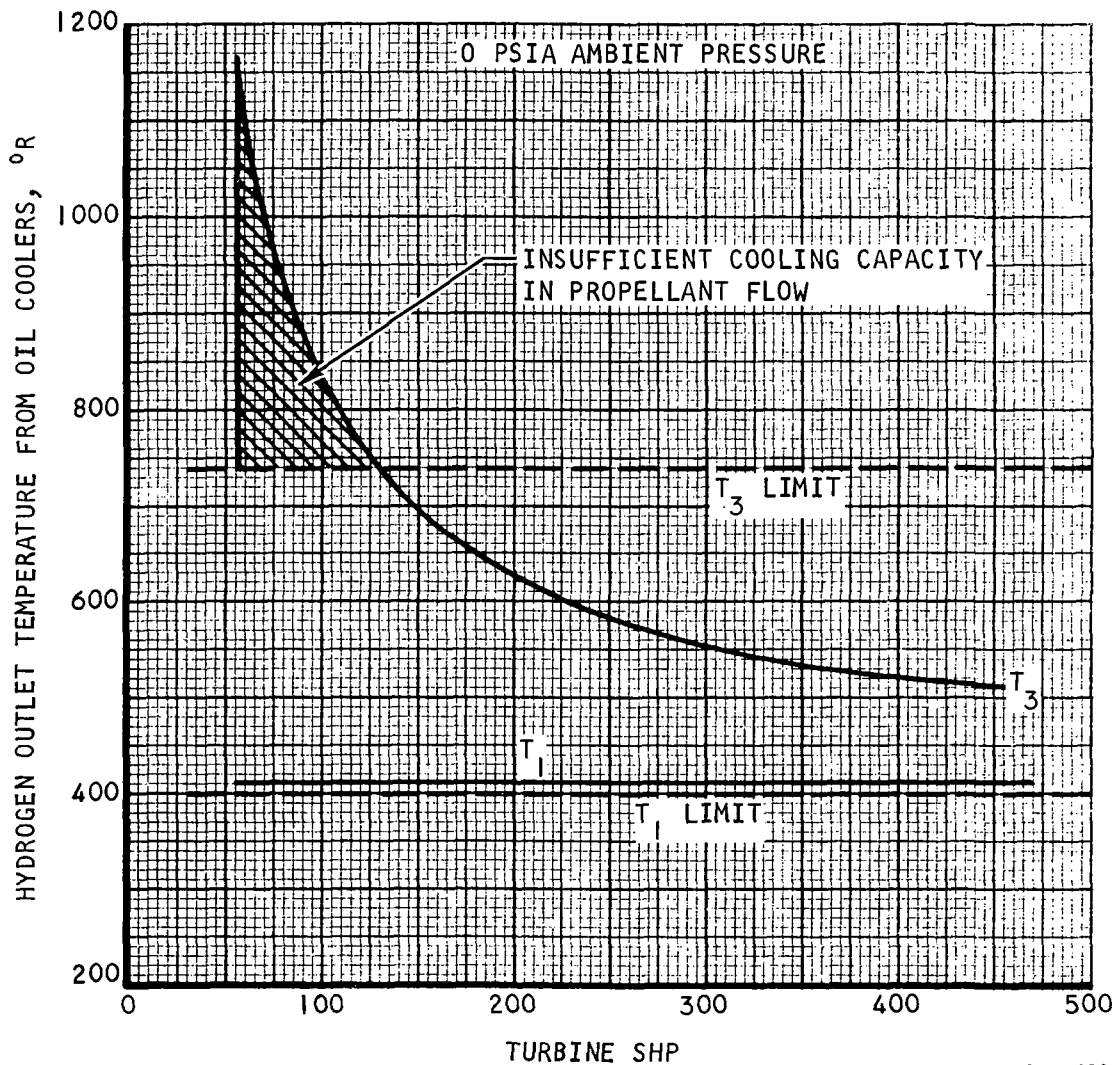
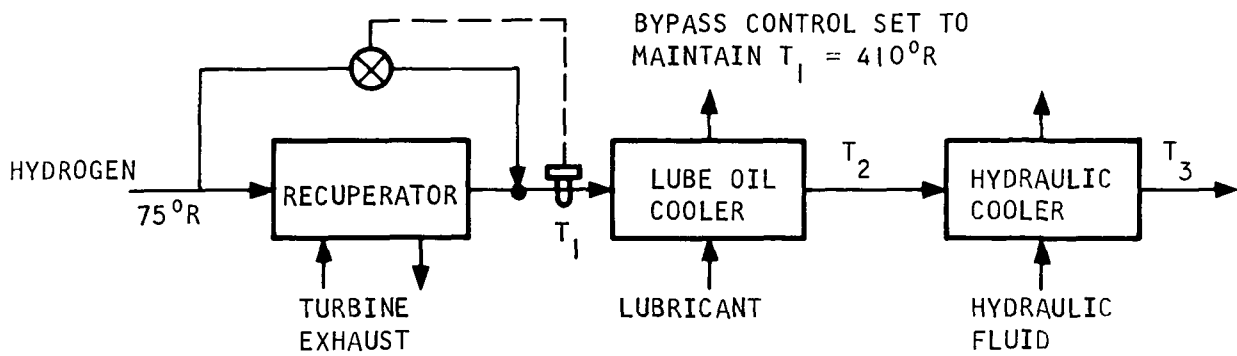
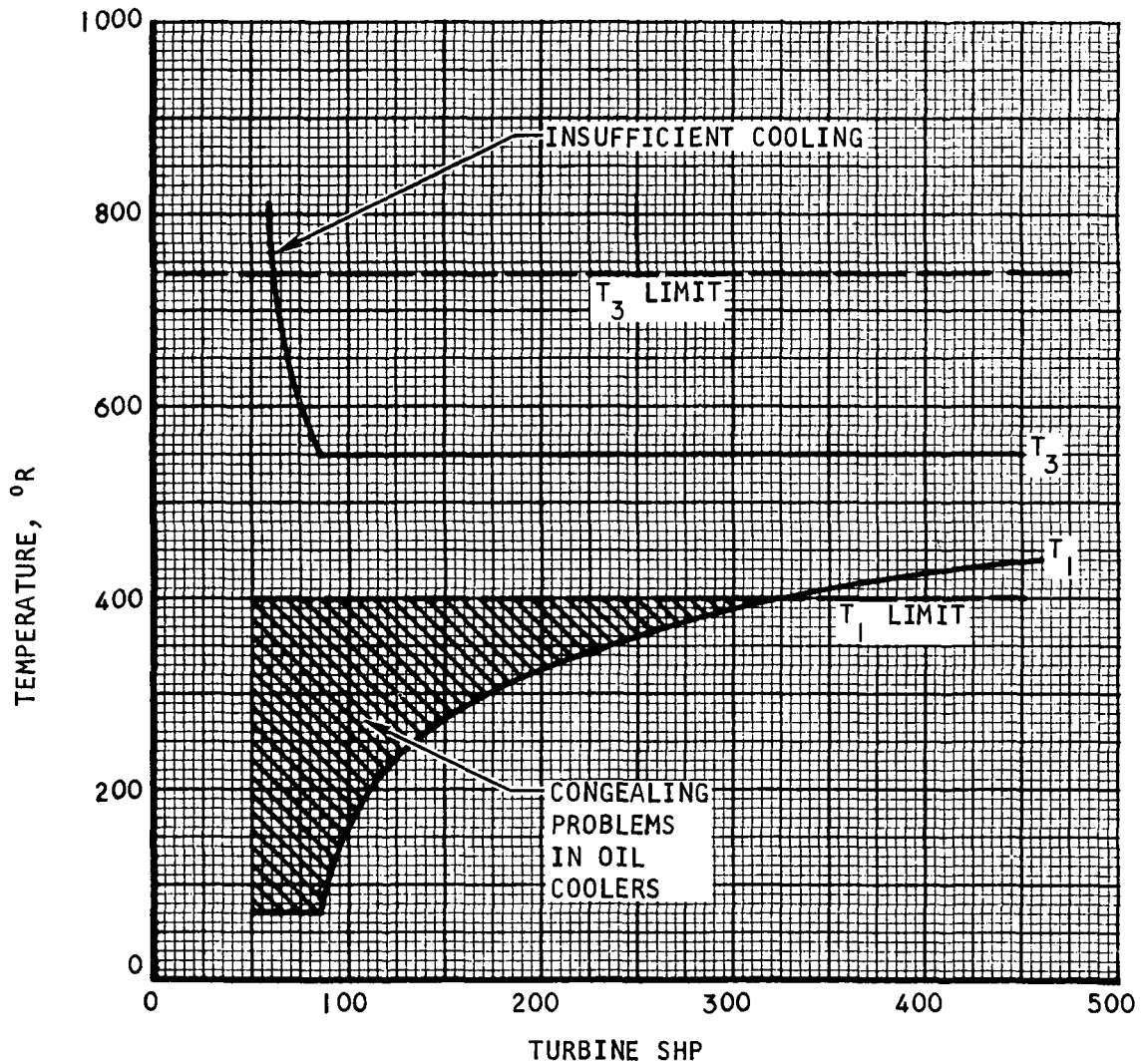
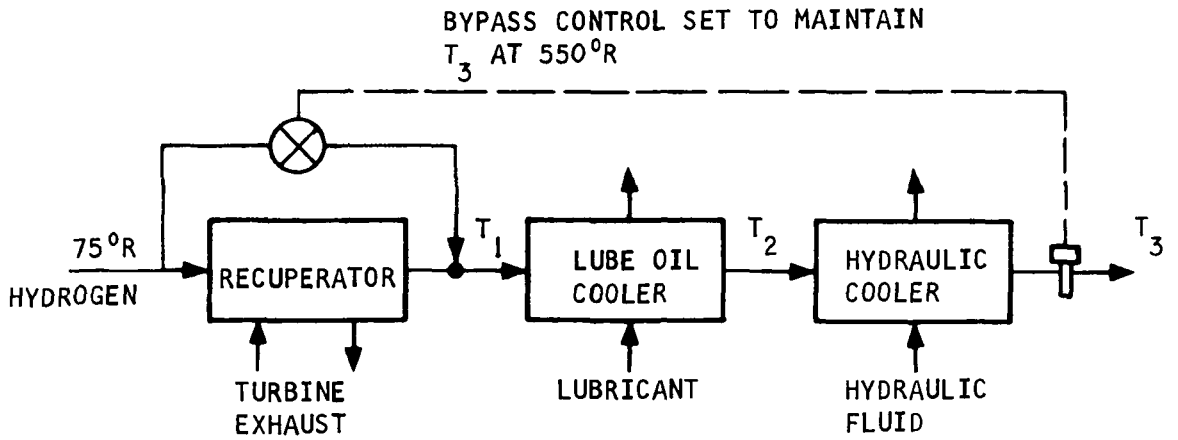

Figure 2-18. Upstream Recuperator Concept with 400°R Temperature Control to Oil Coolers



S-66908

Figure 2-19. Upstream Recuperator with Outlet Temperature Control

a major design problem and one involving high development risk. Also, because of the coupling effect with hydraulic fluid temperature, system arrangement requires a bypass control on the hydraulic cooler. Finally, because of the thermal damping obtained with downstream location of the temperature sensor, this system would not be able to accurately track changes in inlet temperature and both oil coolers could be exposed to low inlet temperatures. These design considerations are discussed in further detail in Section 5 of this volume.

## CONCLUSIONS

Observance of certain temperature limitations with the heat exchangers will significantly reduce design problems and development risk. AiResearch experience has shown that heat exchangers that function over a wide temperature range and operate in regions where large changes in viscosity and other fluid properties occur represent a significantly higher development risk because of the difficulty in accurately predicting heat transfer coefficients and internal flow distributions, even with very sophisticated multiple-nodal computer programs. The baseline thermal management concept leads to heat exchanger design conditions where performance is predictable and development risk, as a consequence, is low. Additionally, because the baseline concept operates with hydrogen temperatures to the oil coolers of  $400^{\circ}\text{R}$ , and a minimum hydrogen temperature to the recuperator of  $520^{\circ}\text{R}$  (based on  $530^{\circ}\text{R}$  hydraulic fluid), there is no possibility of excessive oil congealing or exhaust gas condensation even under any possible off-design conditions.

The analyses show an incentive for locating the lube oil cooler upstream of the hydraulic oil cooler so that the lube oil heat load is always cooled to the desired temperature. The lower rejection temperature allowable for the lube oil (to about  $440^{\circ}\text{R}$ , as opposed to  $530^{\circ}\text{R}$ ) results in an increase in the cycle heat rejection capacity when the lube oil cooler is upstream of the hydraulic oil cooler. Cooling the lube load first gives heat rejection from about  $400^{\circ}$  to  $740^{\circ}\text{R}$  on the hydrogen, whereas placing the hydraulic load first results in rejection only over the range of  $520^{\circ}$  to  $740^{\circ}\text{R}$ .

## SECTION 3

### TURBINE SPEED CONTROL

#### INTRODUCTION

Turbine speed control is accomplished by controlling propellant flow to the gas generator. Two basic types of speed control are available: pressure modulation, in which propellant flow is modulated continuously with varying pressure, and pulse modulation, in which the propellant flow is pulsed at full pressure for varying cycles. Pulse modulation control is more efficient since the turbine operates at full system pressure. However, it imposes high cyclic life requirements on system components. Furthermore, for the specified Space Shuttle vehicle missions, the propellant weight saving is offset by increased fixed component weight (principally in heat exchangers sized for peak flows and gas accumulators required for system stability. In addition, pressure modulation control is adaptable to systems requiring MIL-STD-704A electrical quality standards or synchronization of parallel alternator outputs. As a consequence, pressure modulation control is selected as offering lower development risk for attainment of the Space Shuttle system operating life and reliability goals.

Detailed comparisons were made of pressure and pulse modulation control systems during Phase II. A digital computer program was prepared for analyzing pulse modulation control steady-state performance. This program is actually a transient-state program since the pulse modulation control continuously functions in a transient mode with varying shaft speed. Pressure modulation control performance analysis was accomplished with another digital program that determines component performance throughout the cycle.

#### SELECTION OF TURBINE SPEED CONTROL CONCEPT

The following pages present the studies conducted to select the preferred speed control concept for the APU. The studies assume a system identical to the preferred configuration. Some of the study conclusions would be changed for other APU cycle arrangements.

The two control concepts considered, pressure and pulse modulation, are described and the performance of each is given. In addition to the effects of the control concept on propellant consumption, the material considers the effects on the system components. Based on this information, pressure-modulated speed control is selected. Table 3-1 summarizes the speed control studies.

#### SPEED CONTROL REQUIREMENTS

NASA has specified that the APU must maintain the alternator output frequency at 400 Hz  $\pm 5$  percent. Thus, assuming that the alternator is directly linked via gearing to the turbine, the alternator frequency requirement leads to a turbine speed control requirement of  $\pm 5$  percent. This is a considerably larger tolerance than that allowed by MIL-STD-704A, which is standardly used

TABLE 3-1

## TURBINE SPEED CONTROL CONCEPT COMPARISON

Control Concept	Mission Propellant Consumption (300°R Hydrogen), lb/turbine shp-hr	Steady-State Speed Control	Valve Cycles	Interface Sensitivity		
				Power Output	Exhaust Duct Pressure Drop	APU Propellant Inlet Pressure
Pressure modulation	1.96 for booster 1.71 for orbiter	Better than $\pm 1$ percent	Continuous modulation	Increased power requires only nozzle redesign	5 percent SPC increase for 400 percent $\Delta P$ increase	Increased pressure causes SPC to approach that of pulse modulation
Pulse modulation	1.68 for booster 1.60 for orbiter	$\pm 5$ percent	18,000 for booster 13,000 for orbiter	Increased power requires complete turbine redesign	8 to 15 percent SPC increase for 400 percent $\Delta P$ increase	Doubling pressure gives 5 percent SPC reduction

Control Concept	Interface Sensitivity APU Propellant Inlet Temperature	Effect on Other APU Components				Technology Status
		Turbine Design Point	Combustor Injector $\Delta P$	Heat Exchanger Transient Performance	Pulsing Flow Effects	
Pressure modulation	8 percent SPC reduction for 500°R hydrogen instead of 75°R hydrogen	Up to 10 percent SPC reduction by designing at altitude, part load	3 to 8 percent of inlet pressure	NA	NA	Available
Pulse modulation	Same as pressure modulation	Design point fixed at sea level, full power	10 to 20 percent of inlet pressure	5 lb weight penalty to obtain performance equal to pressure modulation	20 lb weight penalty for accumulators to eliminate pulsing	Long-life pulsing valves required

in both military and commercial APU applications where electric power is generated. That standard requires the steady-state frequency to be maintained within  $\pm 1$  percent of the design frequency and it limits the frequency rate of change to a maximum of 25 Hz/sec. However, the application of MIL-STD-704A to the Space Shuttle APU would eliminate pulse modulation speed control as a candidate concept (assuming direct alternator-turbine link) since pulsing the turbine flow will result in frequency rates of change greater than 300 Hz/sec and designing for  $\pm 1$  percent steady-state speed control is not possible because the control lags inherently limit the minimum speed tolerance to about 2 percent. Therefore, it is assumed that the APU will be designed to  $\pm 5$  percent speed control per the NASA statement of work. However, it should be noted that pressure-modulated speed control will meet MIL-STD-704A, whereas pulse modulation will not.

#### DESCRIPTION OF SPEED CONTROL CONCEPTS CONSIDERED

The two methods of speed control most applicable to the Space Shuttle APU are:

- Pressure modulation--the turbine throughflow, and hence power output, is varied by varying the combustor pressure
- Pulse modulation--the average turbine throughflow is varied by alternately turning the combustor inflow on and off

Pressure modulation is a continuous flow process in which a speed error signal is used to modulate flow control valves located just upstream of the combustor. With such a system, the variations in turbine speed under steady-state output load conditions are negligible. On the other hand, pulse modulation is a discontinuous flow system in which pulses of energy are input to the turbine. The total energy input is controlled by varying the on-time of the flow control valves located in front of the combustor. Consequently, even under steady-state output load conditions, the turbine speed will alternately increase (as an excess of power is added to the turbine) and decrease (as power is extracted from the turbine by the load).

#### PRESSURE-MODULATED PERFORMANCE

The studies conducted during Phase I indicate that the minimum mission propellant consumption is obtained when the turbine is designed for optimum performance at low power conditions. This is because most of the APU output energy occurs at a low power level. Figure 3-1 shows the typical performance of an APU system having a pressure-modulated turbine designed at 67 psia inlet pressure and 8 psia output pressure. It should be noted that increased ambient pressures (which in turn cause an increase in the turbine discharge pressure, and hence a reduction in the turbine pressure ratio) cause a significant increase in the SPC at low power levels.

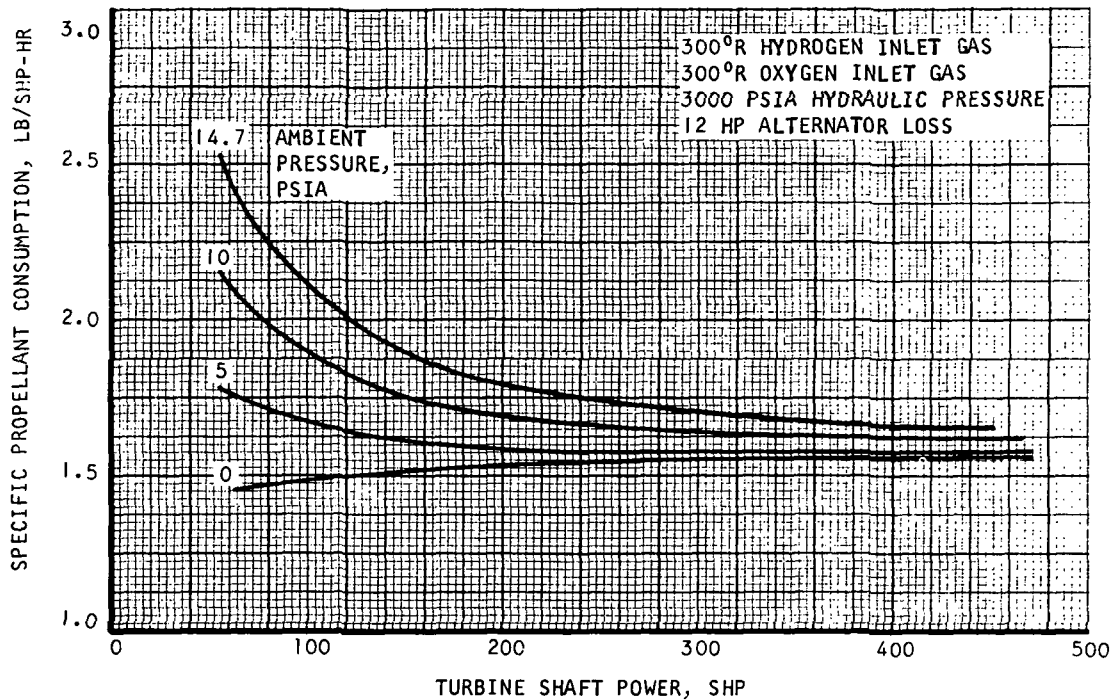

Figure 3-1. Pressure-Modulated APU SPC

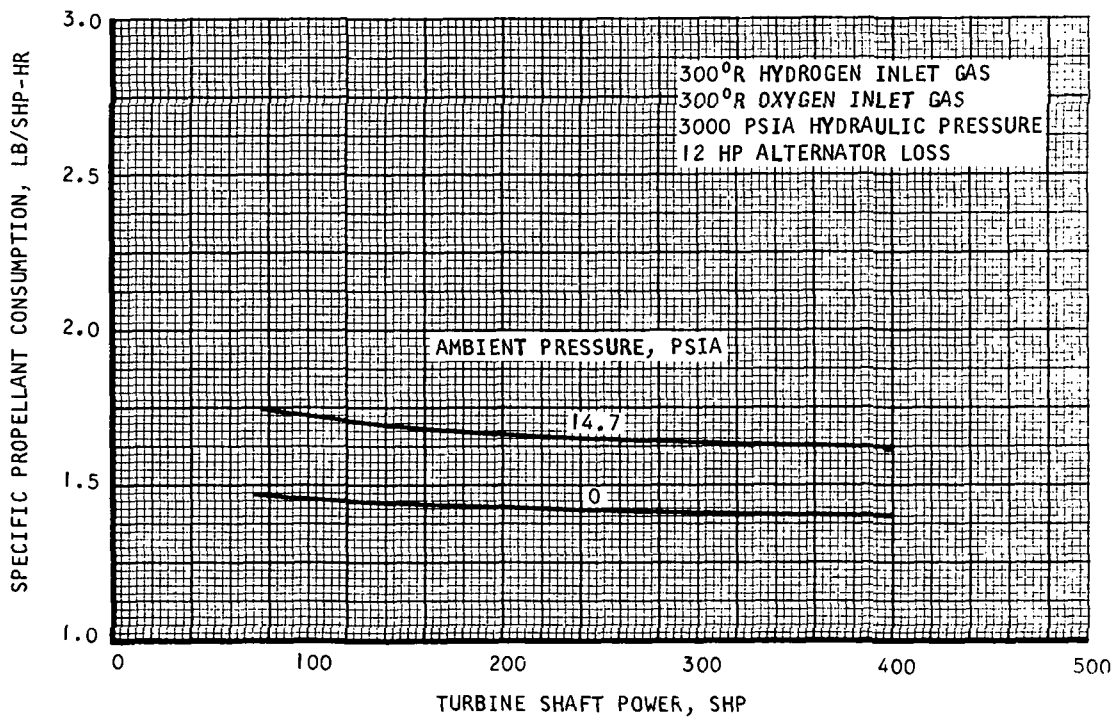

Figure 3-2. Pulse-Modulated APU SPC

S-67005

## PULSE-MODULATED PERFORMANCE

The pulsed turbine must be designed at the maximum power output condition. Figure 3-2 shows the performance of an APU system having a pulse-modulated turbine designed at 450 psia inlet pressure and 17 psia outlet pressure. Although the performance of a pulsed-turbine APU is almost identical to that of the pressure-modulated APU at low ambient pressures, at high ambient pressures and low power outputs, the pulsed turbine shows a significant performance advantage. At 14.7 psia ambient and 100 shp, the pulsed APU requires only 81 percent as much propellant as does the pressure-modulated APU. Thus, the pulse-modulated APU will show a performance advantage for missions in which a large portion of the total energy output occurs at low power and high ambient pressures.

### Control Trip Speed Tolerance

To allow for time lags associated with the control valves and the speed sensor, the pulsed APU must have a control system designed to turn the turbine flow on and off at speed tolerances considerably less than the maximum permissible tolerance of  $\pm 5$  percent. Figure 3-3 shows the relationship between turbine overspeed and underspeed (expressed as a percent of rated speed) and the control trip speed tolerance. The data indicate that the maximum turbine overspeed condition will occur at low loads where the power input to the turbine during pulsing is substantially greater than the power absorbed by the load. Similarly, the maximum underspeed occurs when the load power approaches the pulsed power capability of the turbine.

For the desired  $\pm 5$  percent speed control, the control trip speed tolerance must be about 2 percent. Thus, for the 70,000 rpm turbine, the controls must initiate pulsing flow at a speed of 68,600 rpm and stop flow at a speed of 71,400 rpm. Tightening the control trip speed tolerance to about 0.5 percent ( $\pm 350$  rpm) results in speed control of about  $\pm 2.5$  percent and about 1.5 percent increase in propellant consumption. Thus, it can be concluded that the propellant consumption of a pulse-modulated APU is almost independent of the control trip speed tolerance.

### Valve Cycle Times

With a  $\pm 2$  percent control trip speed tolerance, the cycle times on the control valves will be as shown in Figure 3-4. These data represent the total valve cycle (on-time plus off-time) as a function of the load power and the ambient pressure. Low ambient pressures allow the turbine to develop slightly more power than at sea level so the valve on-time is less than that at sea level. Similarly, sea level ambient pressures cause a windage loss on the turbine during the valve off-time so that the speed deceleration is slightly greater than that at zero ambient pressure. Figure 3-5 shows the on and off times for the valves as a function of the load power and the ambient pressure.

If the control trip speed tolerance is reduced from 2 percent (which gives a 5 percent speed variation) to 0.5 percent (which gives a 2.5 percent speed variation), the total valve cycle duration will be reduced by about 50 percent. Thus, the number of valve cycles during a mission would be doubled.

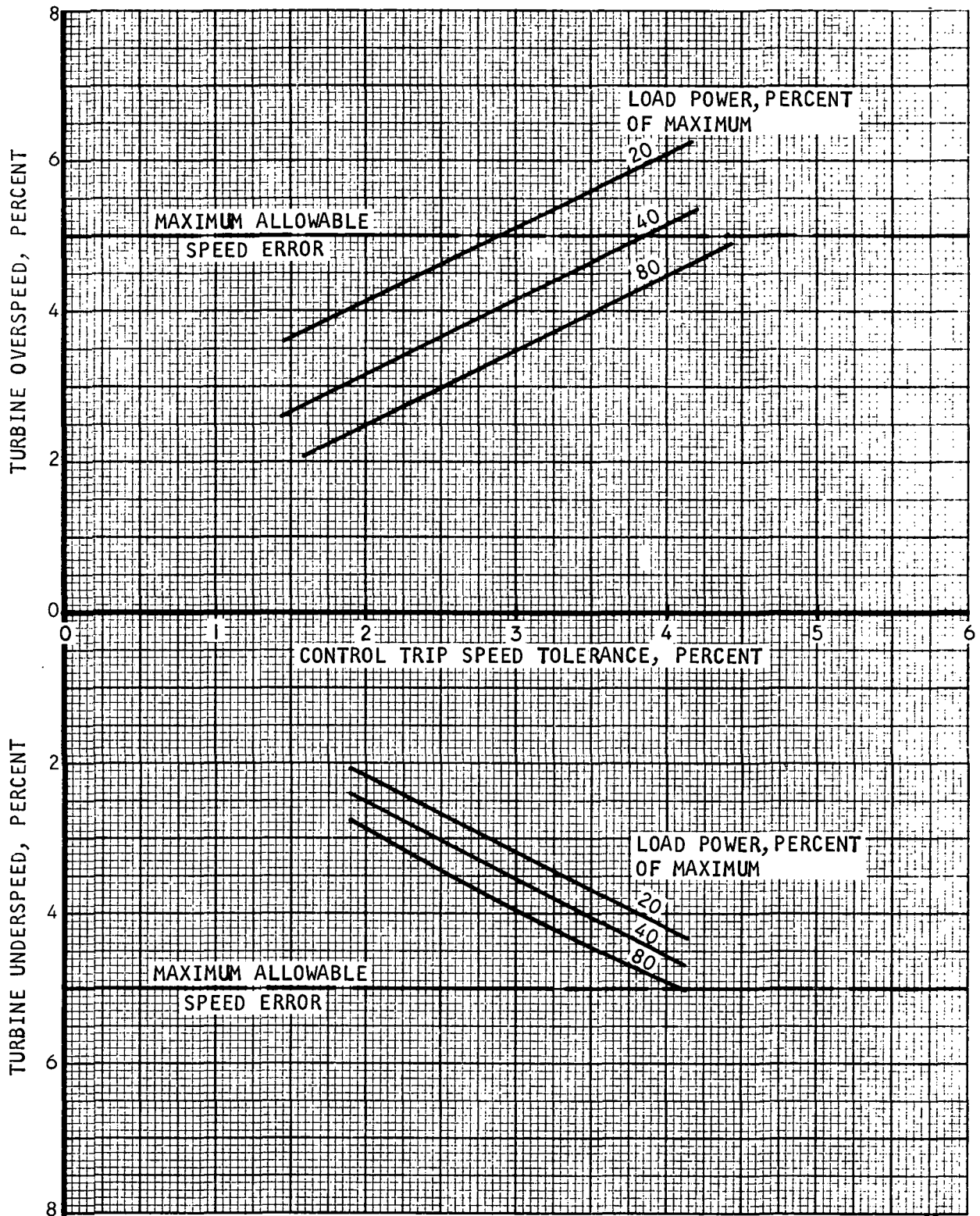
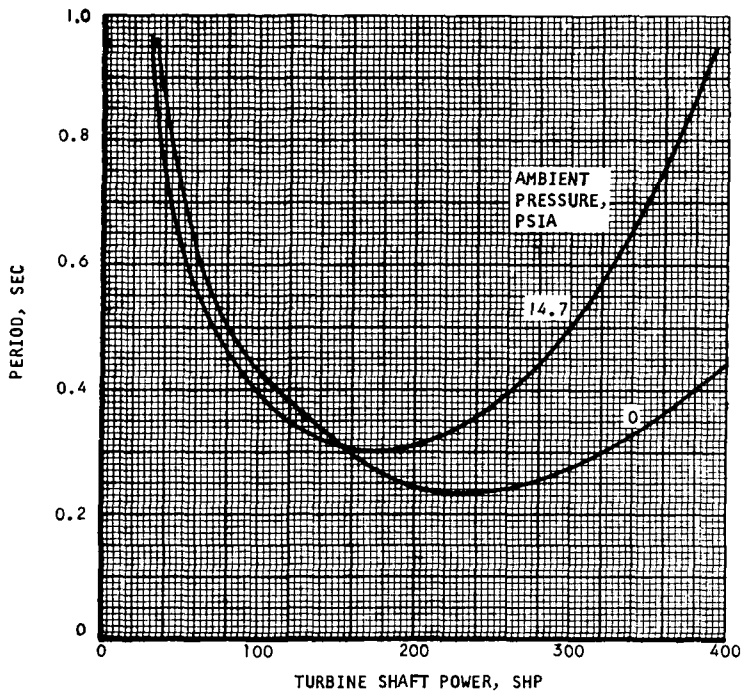

Figure 3-3. Turbine Speed Over/Underspeed vs Control Trip Speed at Zero Ambient Pressure

S-67017



S-67004

Figure 3-4. Pulse-Modulated APU Valve Cycling Period

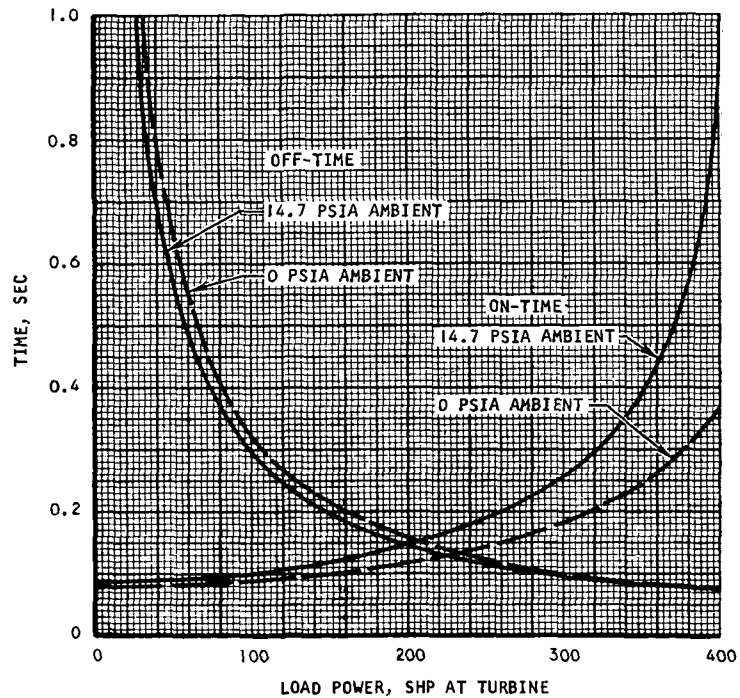

S-67008

Figure 3-5. Pulse-Modulated APU Valve On- and Off-Times

### Speed Variation with Time

Figure 3-6 shows two typical cases indicating the speed variation with time for a pulsed system designed for  $\pm 5$  percent speed control in the worst case. At low loads, the speed deceleration is gradual, but the acceleration is quite rapid. At high loads, the deceleration is rapid and the acceleration is gradual.

#### MISSION PERFORMANCE COMPARISON: PRESSURE MODULATION VS PULSE MODULATION

When the performance of the pressure and pulse-modulated APU's is integrated over the mission profiles specified by NASA for Phase II, the pulse-modulated APU propellant consumption is about 86 percent of that for the pressure-modulated APU on the booster, and about 95 percent of that for the pressure-modulated APU on the orbiter.

Integration of the valve cycles for a pulse-modulated APU providing  $\pm 5$  percent speed control indicates about 18,000 cycles per APU per booster mission and about 13,000 cycles per APU per orbiter mission.

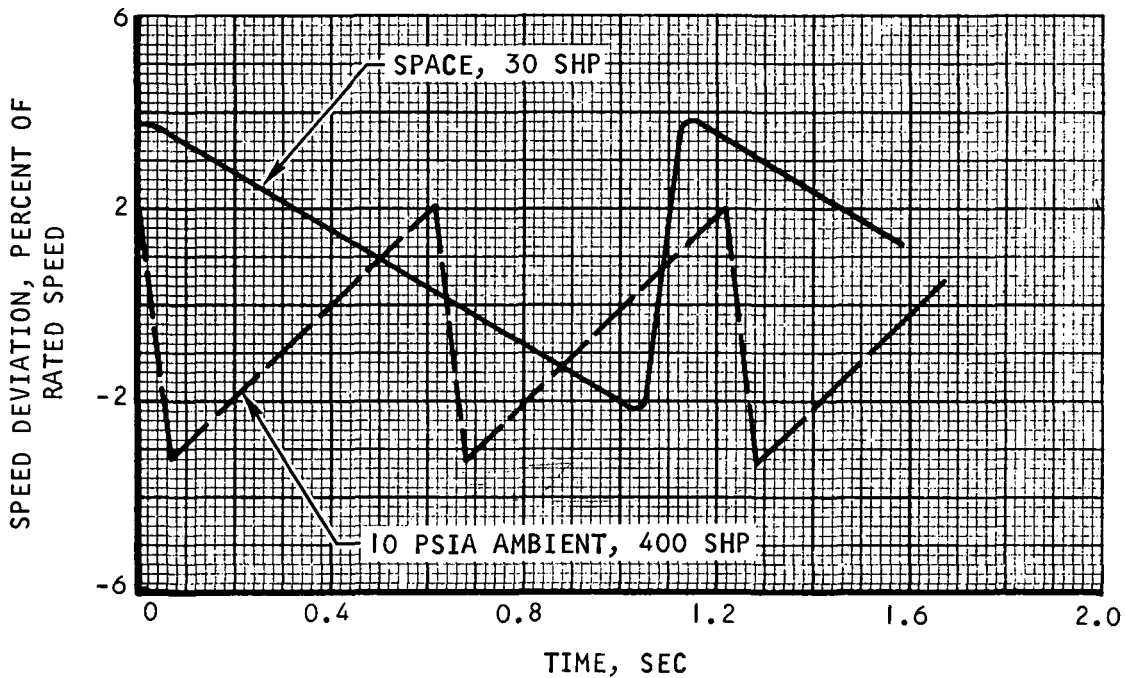

S-67006

Figure 3-6. Pulse-Modulated APU Speed Variations

## SENSITIVITY OF CONTROL CONCEPT TO SYSTEM INTERFACE CONDITIONS

Because the current APU design conditions may be altered by the final vehicle requirements, a sensitivity analysis was performed to assess the effect of changes in various system design parameters dictated by the interface between the APU and the vehicle. The parameters considered are:

- Peak power output
- Exhaust duct pressure drop
- Propellant supply condition to APU

### Peak Power Output

Changes in the peak power output can be readily accommodated by the pressure-modulated system solely by altering the nozzle sizes in the turbine. The turbine wheels will not require any changes. Increased power requirements would increase the pressure losses in the APU components and hence lower the turbine inlet pressure slightly, but this effect is of secondary importance. In a pulsed APU, the turbine second stage will be full admission so that an increased power requirement would necessitate redesign of both turbine nozzles and wheels. As with the pressure-modulated APU, the turbine inlet pressure would be slightly lowered with increased power.

### Exhaust Duct Pressure Drop

The size and length of the APU exhaust duct will be dependent upon the details of the specific vehicle configuration. During Phase II it has been assumed that the exhaust duct is 50 ft in length, 4 in. in OD, and has three 90-degree bends. Such a duct, together with the recuperator, offers a pressure loss of only 1.5 psia at sea level ambient and full turbine output power.

To determine the control concept sensitivity of exhaust duct pressure drop, four pressure drops were considered (2.5, 5, 7.5, and 10 psia pressure drop at sea level full power). For the pulsed APU, the propellant consumption was increased by 8 percent at sea level and 15 percent at 5 psia ambient when the exhaust duct pressure drop was 10 psia in comparison to 2.5 psia. For the pressure-modulated APU, the propellant consumption increase at 10 psia in the exhaust duct was only 5 percent more than that at 2.5 psia.

Thus, it can be concluded that both control concepts are relatively insensitive to changes in the exhaust duct pressure drop.

### Propellant Supply Condition to APU

Because the final APU may be operated either from gas supplied by another vehicle subsystem or from liquid-fed pumps, the maximum operating pressure may vary from the 500 psia used as the baseline during Phase II.

## 1. Pressure Variation

Figure 3-7 shows the change in APU SPC as a function of the maximum combustor pressure for a pressure-modulated system. Figure 3-8 shows similar data for a pulse-modulated APU. The data indicate that the performance superiority of the pulse-modulated control is reduced as the combustor pressure rises. Thus, at the low-power sea level condition, the pulsed APU consumes 81 percent of the propellant required by the pressure-modulated system at 450 psia inlet pressure; when the pressure is increased to 850 psia, the pulsed system uses 86 percent of that for the pressure-modulated system at the low-power, sea level condition.

## 2. Temperature Variation

NASA has specified large variations in the hydrogen and oxygen inlet temperatures to the APU. These variations are representative of the possible gas conditions in the Auxiliary Propulsion System (APS) accumulators. The effect of inlet temperature changes is identical for both control concepts. It changes the O/F ratio and hence the SPC by up to 8 percent (between 75<sup>0</sup> and 500<sup>0</sup>R hydrogen inlet temperature).

### INTERACTION BETWEEN CONTROL CONCEPT AND OTHER APU COMPONENTS

In addition to the interaction between the control concepts and the vehicle interfaces, there is considerable interaction within the APU itself. In particular, the following variations have been considered:

- Turbine design point
- Combustor injector  $\Delta P$
- Heat exchanger transient flow performance
- Ducting and heat exchanger  $\Delta P$  upstream of turbine
- Pulsing flow effects on components

### Turbine Design Point

With a pulsed APU, the turbine will always operate at the peak inlet pressure. Thus, the turbine must be designed for peak power output at the maximum ambient pressure, sea level. With a pressure-modulated system, the turbine must also be capable of providing peak power at sea level, utilizing the maximum available pressure. However, it is possible to design the turbine nozzle for optimum performance at a lower inlet pressure condition. Thus, the turbine performance can be tailored to the particular mission profile. For the Space Shuttle, up to 10 percent reduction in pressure-modulated APU SPC is obtained by designing the turbine nozzle for optimum performance at an altitude, part power condition.

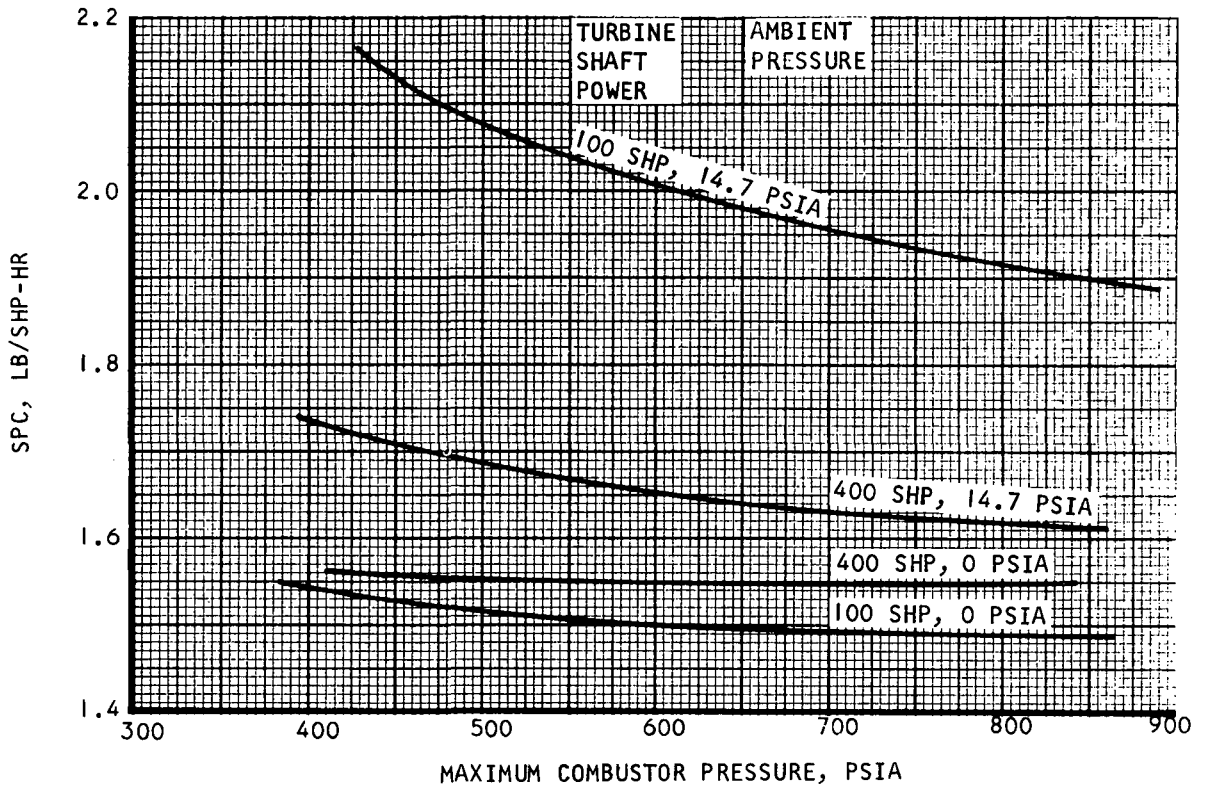

Figure 3-7. APU SPC vs Maximum Combustor Pressure for Pressure-Modulation Control

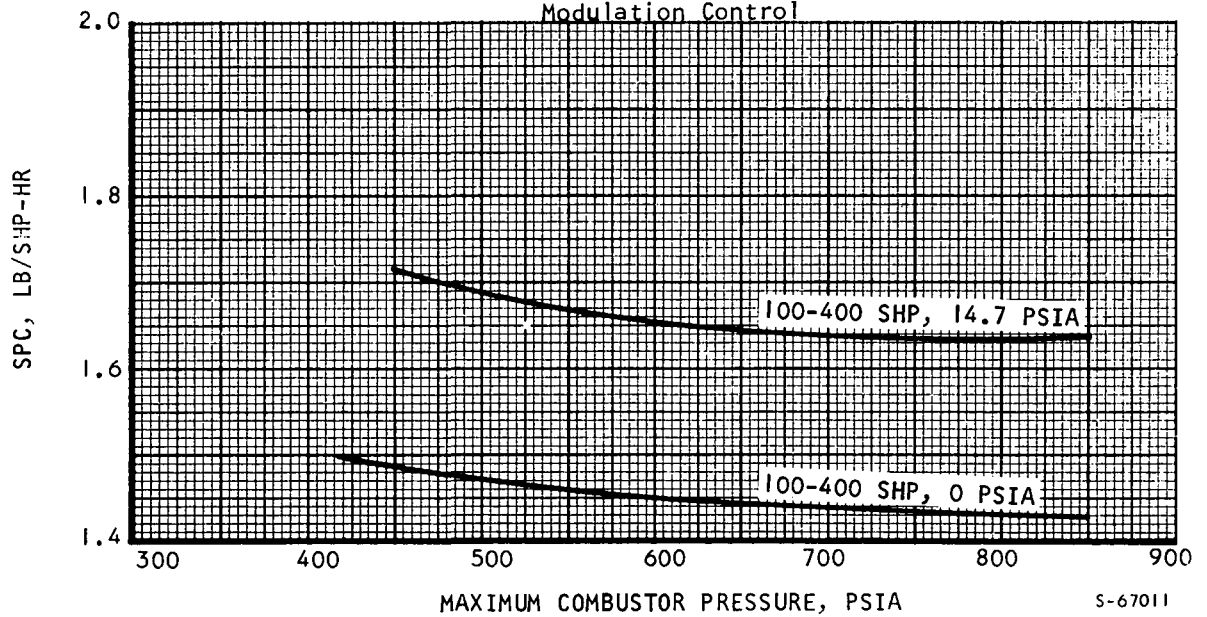

Figure 3-8. APU SPC vs Maximum Combustor Pressure for Pulse-Modulation Control

## Combustor Injector $\Delta P$

Because the flow is discontinuous, a pulsed APU must be designed with a relatively high combustor injection pressure drop to insure stability. On the other hand, a pressure-modulated APU can operate with a low pressure drop (as demonstrated at AiResearch). Thus, for the same supply pressure, the maximum combustor pressure with a pressure-modulated APU will be greater than that for a pulse-modulated APU.

## Heat Exchanger Transient Flow Performance

Transient studies of the APU heat exchangers have indicated that their performance in a pulse-modulated APU is essentially that at a continuous flow equal to the peak pulsing flow. Since the effectiveness of a heat exchanger decreases as the flow is increased, the pulsed system will always be operating at heat exchanger effectivenesses less than those for the pressure-modulated system, assuming identical heat exchangers. Or, alternatively, to obtain identical mission-averaged heat transfer capability, the pulse-modulated system will require slightly larger heat exchangers. The weight penalty to the pulsed system to obtain identical heat transfer capability is estimated at about 5 lb.

## Ducting and Heat Exchanger $\Delta P$ Upstream of Turbine

The total pressure drop between the APU inlet and the flow control valves is small. Consequently, any differences between the two control concepts will not noticeably affect the inlet pressure to the flow control valves.

## Pulsing Flow Effects on Components

The flow discontinuities occurring with a pulse-modulated APU will cause cyclic changes in the pressures. Thus, the heat exchanger joints will be subjected to a slight stress cycling that could lead to fatigue. The flow acceleration and deceleration losses in the jet pump are unknown; however, it is anticipated that jet pump performance would be affected deleteriously. Also, the pressure fluctuations could cause cycling or instability in the pressure regulator at the APU inlet. All three of these problems with pulsed control can be eliminated by placing appropriately sized accumulators in the hydrogen and oxygen lines adjacent to the flow control valves. It is estimated that such accumulators would weigh about 20 lb. Stability studies presented in Section 7 of this volume indicate that accumulators are not required by the pressure-modulated APU.

## TECHNOLOGY STATUS

Pressure- or flow-modulated control systems are standardly used in almost all turbine applications. Thus, there is a broad technology base available for pressure modulation. Pulse modulation systems are standardly used in attitude control systems; thus there is also an established technology. However, most of the attitude control systems are designed for a single mission in which the

total number of valve cycles is on the order of 2000. For the Space Shuttle vehicle, where the design requirement is a 100-mission life, about 2-million valve cycles are required. Consequently, a significant advance in cycling valve life will be required.

The electronics associated with valve control are approximately equivalent for both concepts and have an established technology base.

## SECTION 4

### TURBINE INLET TEMPERATURE CONTROL

#### INTRODUCTION

Turbine inlet temperature varies with the propellant inlet temperature to the combustor and the O/F ratio, as shown in Figure 4-1. This section of the report is concerned with the means of maintaining turbine inlet temperature within desired limits. NASA has specified a 2060°R maximum turbine inlet temperature for the Space Shuttle APU. It is not necessary to control turbine inlet temperature directly. It can be controlled indirectly (for example, by controlling inlet hydrogen temperature and O/F ratio) or allowed to float (limited to a maximum level obtained at a particular condition, such as minimum output power at sea level ambient pressure, for example). This direct and indirect control of turbine inlet temperature can be accomplished by a variety of active and passive control methods that will be described and compared in this section.

#### TEMPERATURE SENSORS

It should be mentioned at this point that the APU system has two additional requirements for turbine inlet temperature sensing. One of these represents a safety device to shut the system down in event of system failure, which would lead to excessive temperatures and would, as a consequence, impose a hazard to safety. The other is a monitoring function, to indicate health and performance capability of the APU. Thus, there is a minimum of two and possibly three requirements for turbine inlet temperature sensing. The requirements for sensor response will not be the same, however, and where the sensor is used for active control of turbine inlet temperature, sensor response will be more important. AiResearch transient-state studies of control system performance indicate no great problem in attaining the required sensor time constant. This conclusion is verified by AiResearch tests with a hydrogen-oxygen APU using closed-loop control of both total propellant flow and O/F ratio. Entirely adequate performance was obtained using a sensor with a 2-sec time constant.

#### Sensor Location

Direct active control of turbine inlet temperature requires temperature sensors that can be located in the turbine inlet, between the turbine stages, or in the turbine discharge (with auxiliary sensors and electronic circuitry to back-calculate inlet temperature). Considerable state-of-the-art experience exists with all of these approaches in gas turbine APU's and propulsion engines. The turbine interstage location is preferred for the present application since it:

Provides a direct indication of inlet temperature without compensation (interstage temperature is directly dependent on turbine inlet temperature and first stage efficiency, which is constant since the first stage always operates at the same pressure ratio)

Provides a convenient location for packaging

Results in high sensor response because of the high gas velocities in the interstage region

Operates at a lower temperature (approximately 1705°R as compared with a 2060°R turbine inlet temperature)

The interstage location has been used successfully at AiResearch on a gas turbine APU for an acceleration power limiting control that required a time constant on the order of 1 sec to avoid turbine overtemperature during startup.

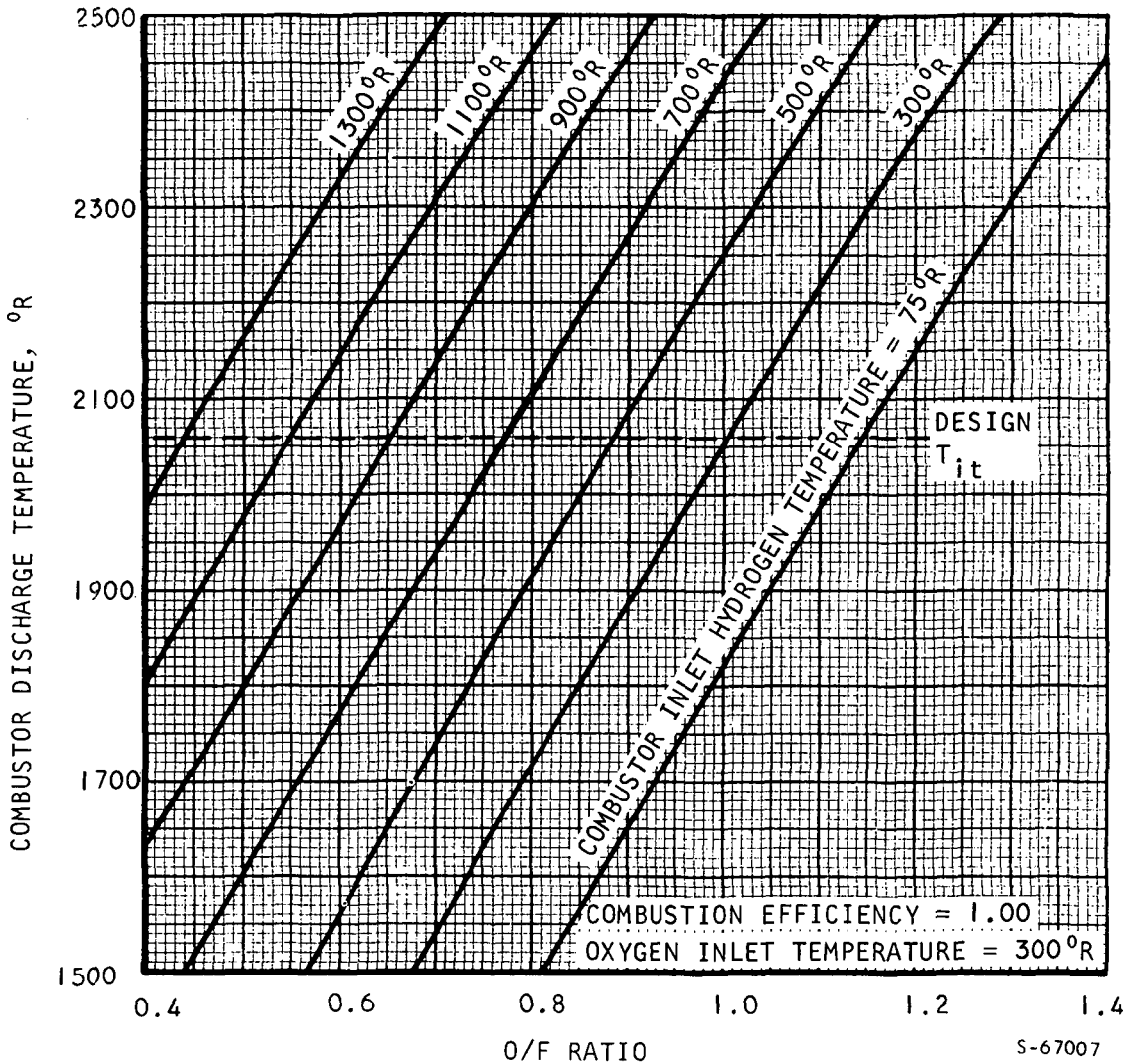

Figure 4-1. Hydrogen-Oxygen Combustion Chart

## Type of Sensor

The Dyna-Soar (X-20) APU control system used thermistor-type temperature sensors. Platinum was found to be an unsuitable resistance material because of excessive drift in calibration ( $80^{\circ}\text{F}$  in 100 hr). Tungsten and molybdenum resistance elements provided satisfactory performance but were fragile and expensive.

Thermocouples are obviously suitable for the temperature range of interest here ( $1705^{\circ}\text{R}$  for the selected sensor location). AiResearch is currently using thermocouples for overtemperature limit controls, turbine inlet temperature controls, and turbine inlet temperature monitors in production gas turbine APU's and propulsion engines at operating temperatures up to  $2060^{\circ}\text{R}$ . From this it can be concluded that temperature by itself is not a problem. Operation in the hydrogen environment could be a problem, since the hydrogen will diffuse through any thermocouple sheathing and cause performance degradation of many thermocouple materials. Thermocouples using tungsten-rhenium and Geminol materials have given satisfactory performance in hydrogen. A tungsten-5%rhenium/tungsten-26%rhenium thermocouple has been selected for the present application, based upon recommendation of a reliable supplier. Tungsten materials must be protected against oxygen and, as a consequence, a shielded design is required. Analysis of the sensor response characteristics indicates that a satisfactory time constant is readily attainable with a shielded design of this type.

## TURBINE INLET TEMPERATURE CONTROL CONCEPTS

Studies were performed of other methods that do not actively sense and control turbine inlet temperature, to evaluate the incentive for active turbine inlet temperature ( $T_{it}$ ) control. These alternate systems (summarized in Table 4-1) either allow a variable  $T_{it}$  (with fixed or variable O/F or maintain constant  $T_{it}$  (at constant O/F by maintaining hydrogen temperature constant and equalizing temperature and pressure to the propellant flow control valves). In general, these alternate systems compromise performance in one way or another to eliminate the active  $T_{it}$  control function. Because these studies were performed at an earlier date than the performance data of Volume V, the baseline system performance data are not quite identical. However the data for all the concepts here are presented on a consistent basis.

### Constant $T_{it}$ Variable O/F Control (Baseline)

The baseline system, shown in Figure 4-2, uses a turbine shaft speed signal (N) to control propellant flow at constant O/F. The oxygen flow control is trimmed to maintain steady-state  $T_{it}$  constant, by sensing and controlling turbine interstage temperature. Figure 4-3 shows the specific propellant consumption and O/F ratio as a function of turbine shaft power and ambient pressure. With this system, the O/F ratio varies over a range from 0.56 (for minimum output power at sea level) to 0.730 (for maximum output power in space).

TABLE 4-1

TURBINE INLET TEMPERATURE CONTROL METHODS

Requirement	Options	Control Type	Remarks
Constant $T_{it}$	Variable O/F } Oxygen or control } hydrogen } flow trim	Active, sense $T_{it}$	Optimum performance.
Variable $T_{it}$	Variable O/F	Passive	Most simple system. $T_{it}$ varies over wide range, decreasing with increasing load.
Constant $T_{it}$	Constant O/F } Hydrogen } tempera- } ture } control	Passive for $T_{it}$ Active for $T_{HYD}$	Reduced cycle recuperation. Propellant temperature and pressure measurement or equilization required.
Variable $T_{it}$	Constant O/F	Passive	Propellant temperature and pressure measurement or equilization required. $T_{it}$ decreases with increasing load, resulting in reduced performance at full power.

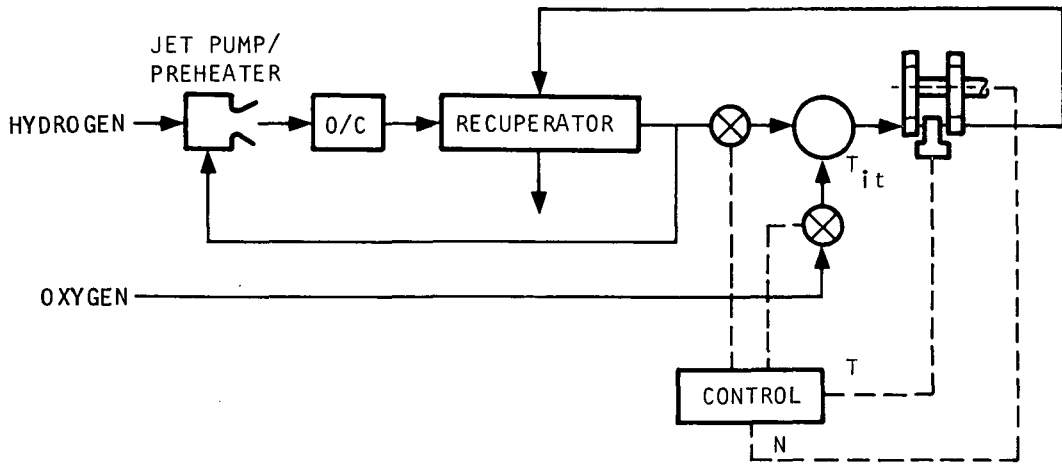

S-67010

Figure 4-2. Constant  $T_{it}$  Variable O/F Control (Baseline)

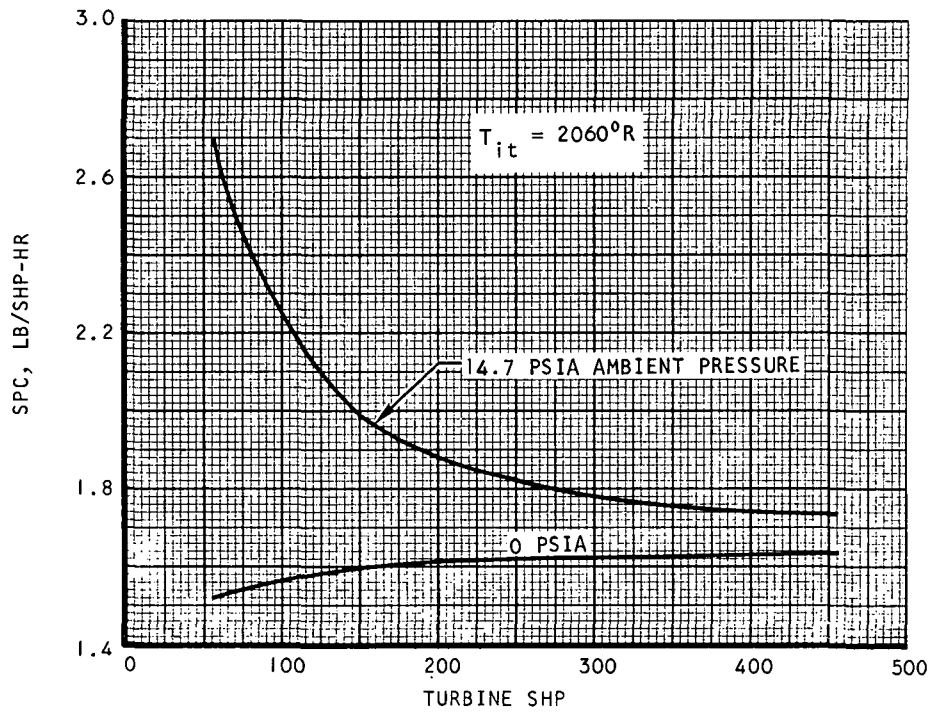
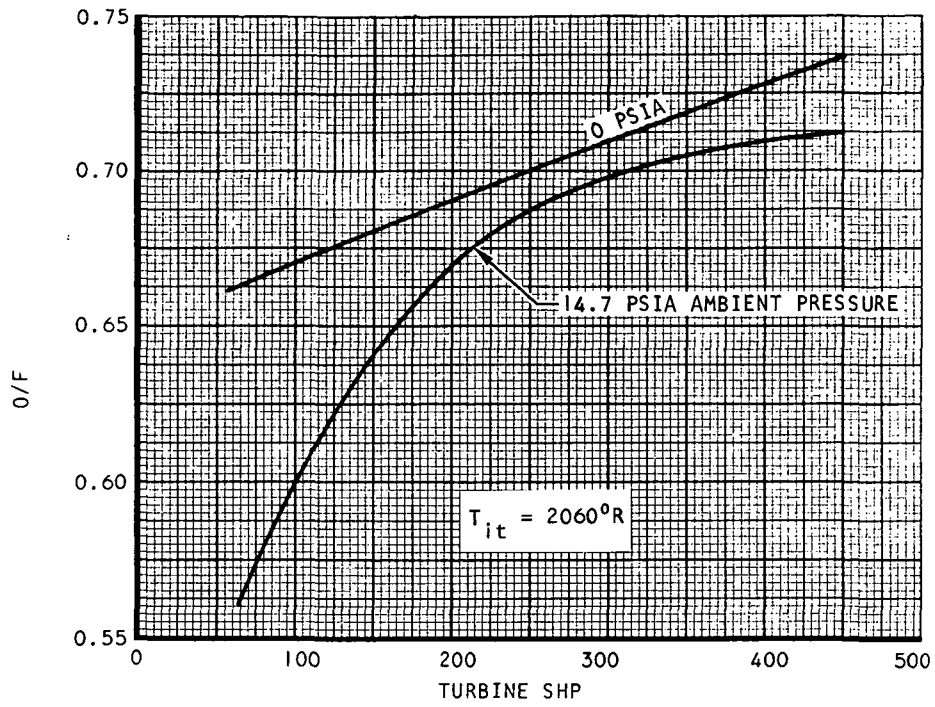

S-66530

Figure 4-3. Typical Constant  $T_{it}$  Variable O/F Control System Performance

## Variable $T_{it}$ Variable O/F System

With this system (shown schematically in Figure 4-4), both propellant flows are modulated to maintain a constant valve area ratio between the oxygen and hydrogen flows. As a consequence, the O/F ratio varies according to the inlet temperatures and pressures of the hydrogen and oxygen. Therefore, both O/F and  $T_{it}$  float and vary as determined by the conditions obtained in the loop.

The steady-state cycle performance program was modified to evaluate the performance of this system with the results shown in Figure 4-5. Maximum turbine inlet temperature is obtained at 14.7 psia ambient pressure and minimum power output. A significant reduction in turbine inlet temperature is obtained under other conditions that would lead to an overall increase in propellant consumption on the order of 50 percent over the baseline system. This analysis did not include consideration of the effect on cycle performance of varying propellant inlet conditions, some of which could result in excessively high turbine inlet temperatures. It is concluded that this approach leads to excessively high performance penalties and has limited flexibility in accommodating a range of propellant inlet conditions. It is therefore noncompetitive as a primary control approach but may be of interest for a degraded performance mode, occurring under certain failure conditions.

## Constant $T_{it}$ Constant O/F Control

To maintain constant  $T_{it}$  at a constant O/F ratio, it will be necessary to modulate the amount of cycle recuperation and control hydrogen temperature from the recuperator. The constant O/F control requires equalization of temperature, that is, a temperature-equalizing heat exchanger (T/E) and pressure-equalizing valves (P/E) upstream from the propellant flow control (F/C) valves. Figure 4-6 shows a system of this type using a recycle loop to control hydrogen inlet temperature to the oil coolers (O/C). In the system schematic shown in Figure 4-7, control of the hydrogen inlet temperature to the oil coolers is provided by a recuperator section.

### 1. Recycle Loop System

This type of system has also been analyzed by modifying the steady-state performance program. It was found that cycle performance is significantly reduced by the requirement for constant recuperator discharge hydrogen temperature. In the case of the system shown in Figure 4-6, the O/F ratio is set at the maximum value ( $O/F = 0.736$ ) required to produce the desired turbine inlet temperature at full load. The 2-percent performance penalty relative to the baseline is represented primarily by an increased oxygen requirement for part-load operation. In other words, cycle recuperation is reduced at part load. This performance penalty excludes the further degradation (totalling 10 percent) required because of the use of open-loop O/F control.

### 2. Split Recuperator System

With the system shown in Figure 4-7, the performance penalty is greater since the maximum recuperation is set at a lower level. For example, the maximum oil cooler hydrogen-side  $\Delta T$  is nearly equal to 250°F at minimum load. At



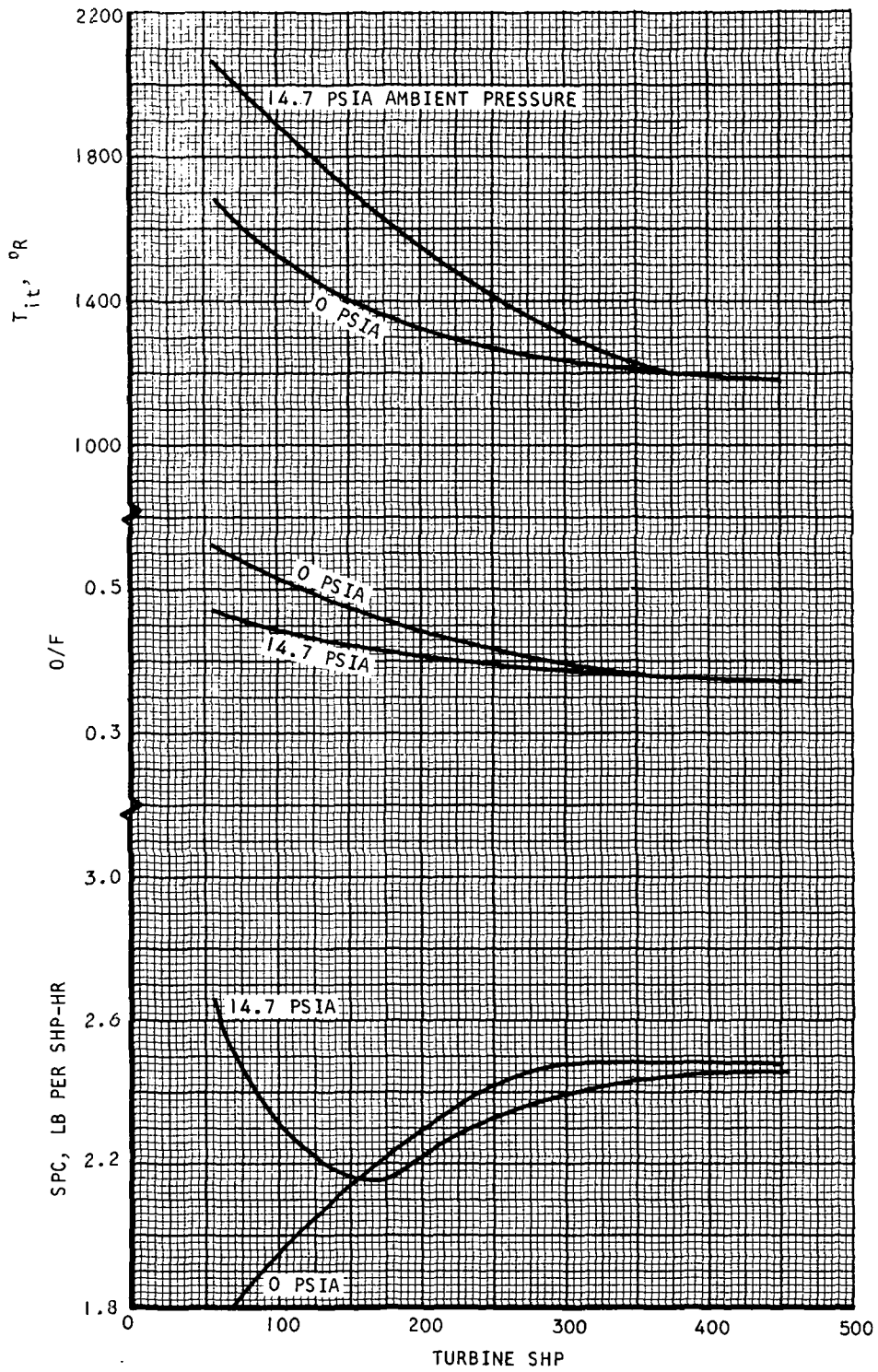

S-67026

Figure 4-5. Variable  $T_{it}$  Variable O/F System Performance

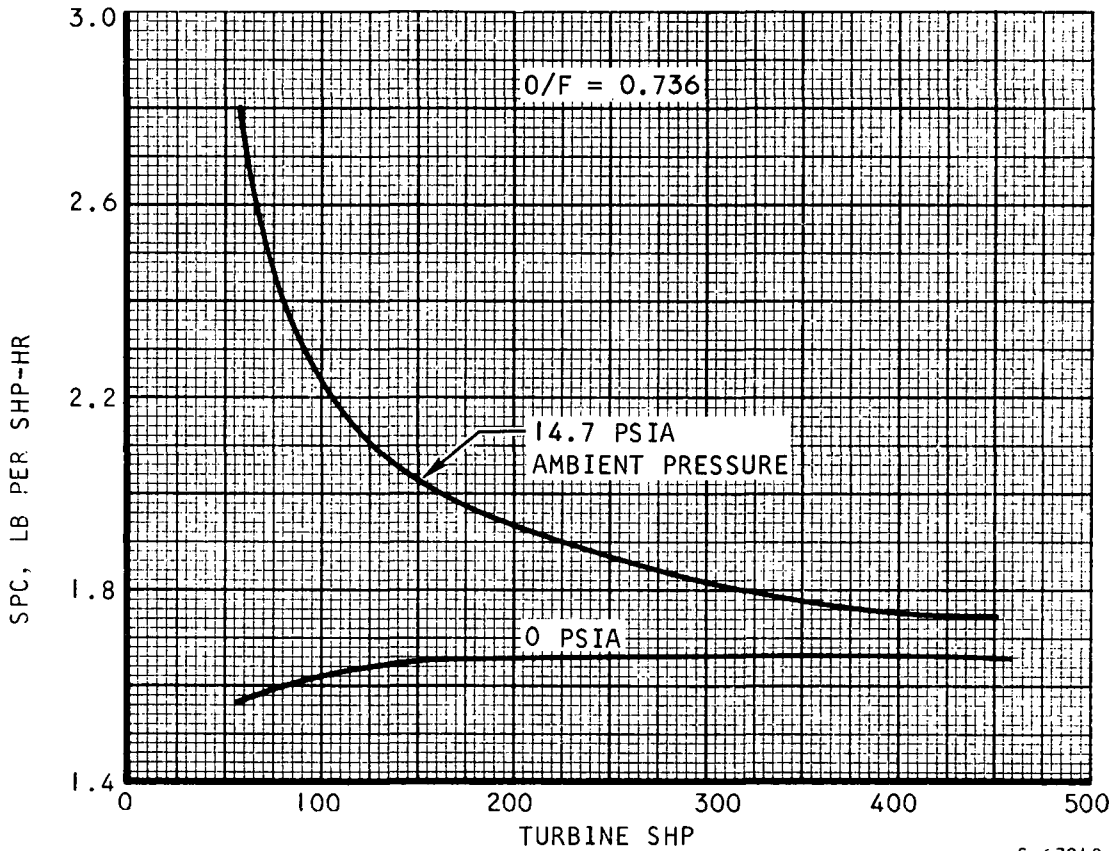
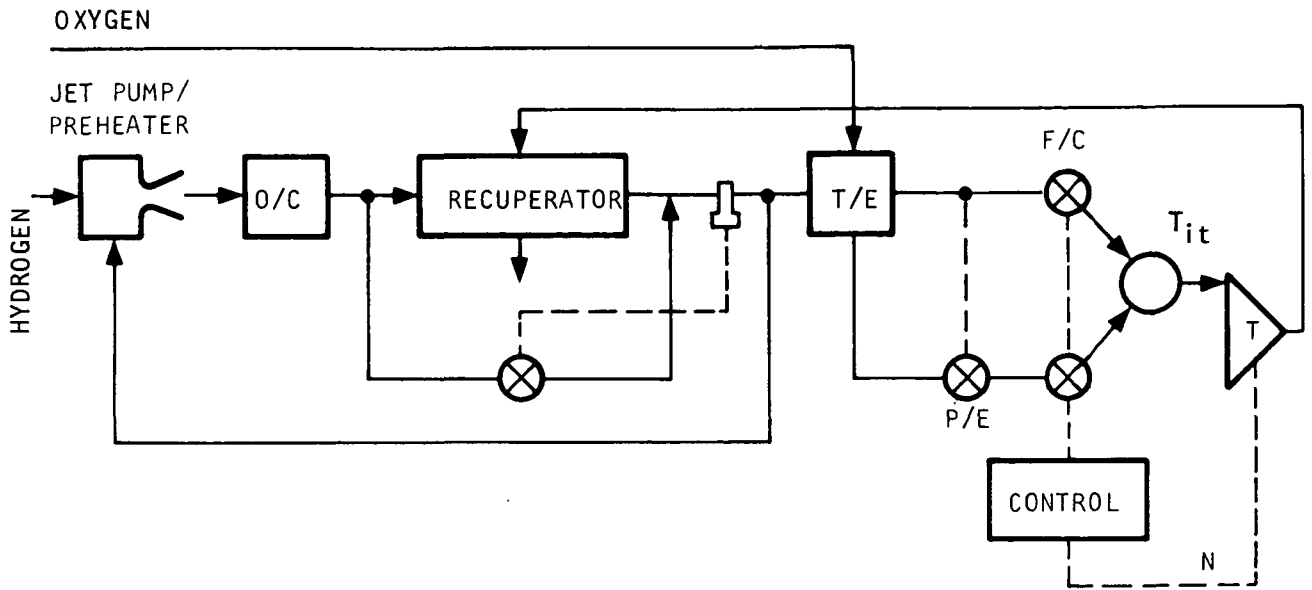

S-67018

Figure 4-6. Constant  $T_{it}$  Constant O/F Control  
(Recycle Loop System)

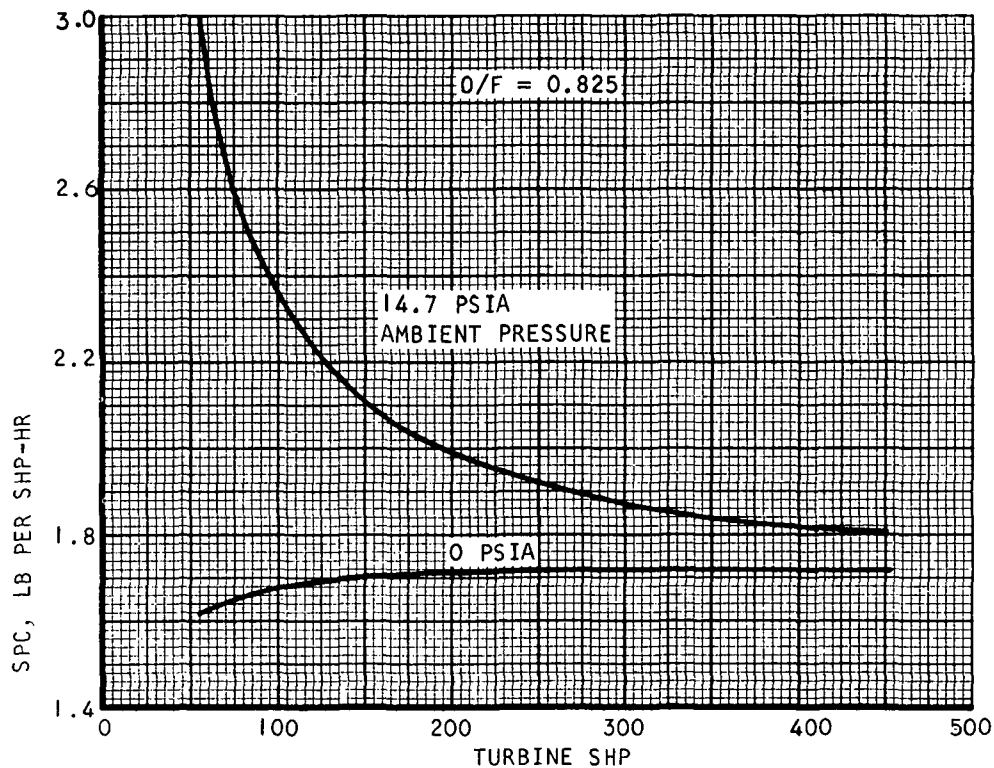
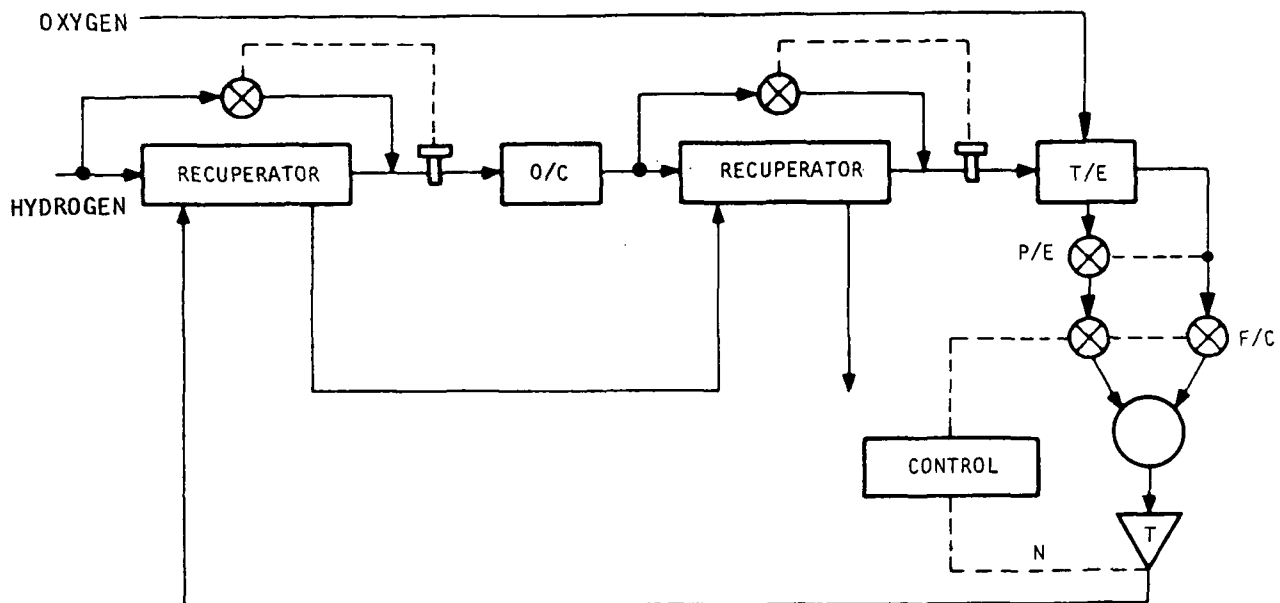

Figure 4-7. Constant  $T_{it}$  Constant O/F Control  
(Split Recuperator System)

S-66532

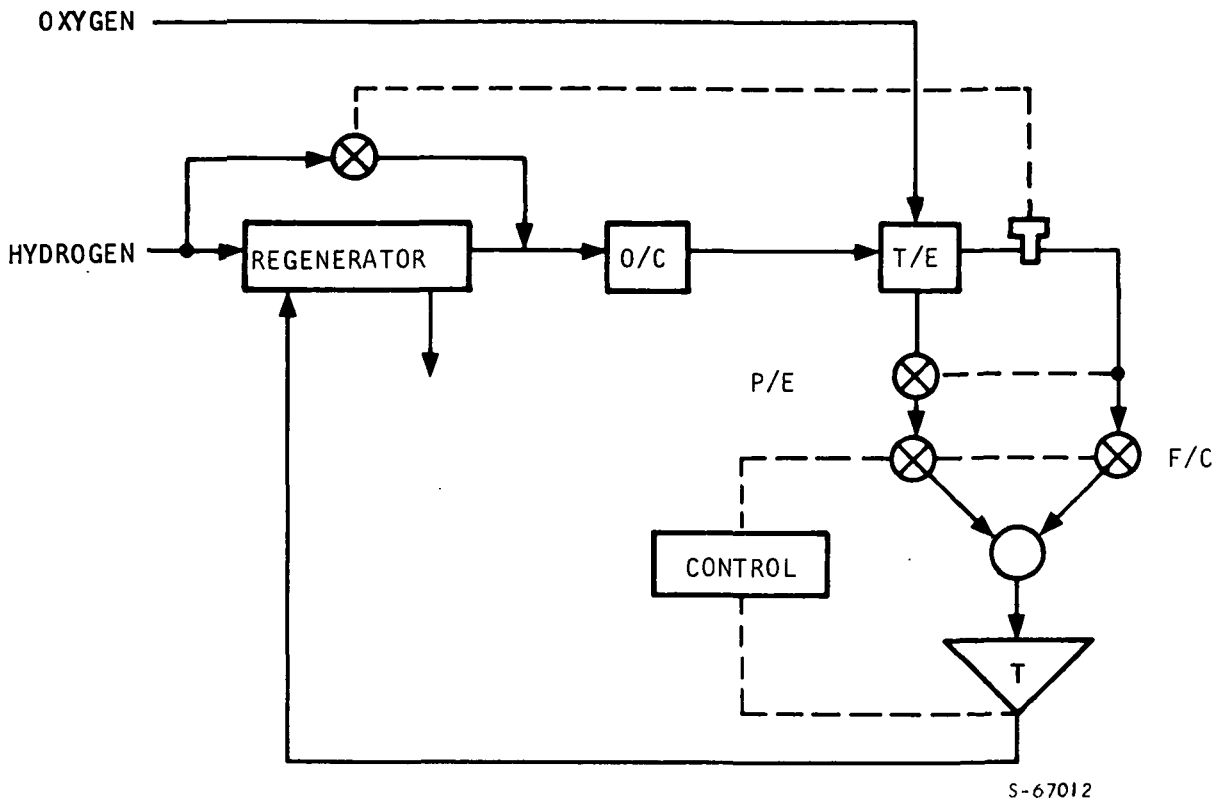

Figure 4-8. Constant  $T_{it}$  Constant O/F Control  
(Recuperator Bypass System)

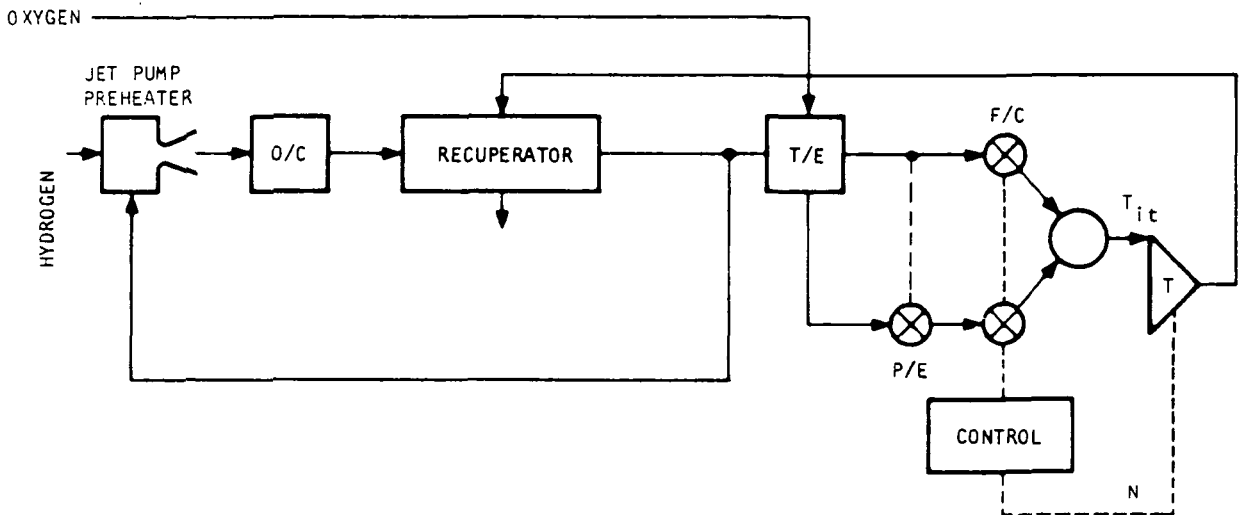

Figure 4-9. Variable  $T_{it}$  Constant O/F System

## Variable $T_{it}$ Constant O/F System

This system, shown in Figure 4-9, maintains constant O/F ratio by temperature and pressure equilization, but has a floating turbine inlet temperature that is determined by the hydrogen inlet temperature obtained in the cycle (with no direct temperature control). Maximum turbine inlet temperature is obtained at minimum load and maximum hydrogen supply temperature to the cycle. It is evident that this system will not accommodate a wide range of hydrogen supply temperature.

The steady-state performance program was again modified for performance analysis of this system. Figure 4-10 shows the variation in  $T_{it}$  with output power for sea level and space ambient pressure conditions and a constant O/F of 0.57. As compared with the baseline system approach (variable O/F, constant  $T_{it}$ ), a 39-lb (13.1-percent) penalty is obtained for the NASA booster mission and a 39-lb (14.2-percent) penalty in propellant weight is obtained for the NASA orbiter mission. Figure 4-10 shows typical system performance.

## CONCLUSIONS

Table 4-2 summarizes the comparison between the various methods of maintaining turbine inlet temperature within desired limits (below  $2060^{\circ}\text{R}$ ). The baseline approach shows the lowest propellant consumption. The temperature sensor required by this system is within the present state of the art. The next best performing system (constant  $T_{it}$  and O/F control with recycle loop) is similar in general configuration to the baseline with the turbine temperature sensor being replaced by a bypass temperature control across the recuperator. The split recuperator approach has a high weight penalty for supplemental cooling (using water as an expendable evaporant) for absorbing the internally generated waste heat. The recuperator bypass concept has a high development risk (discussed in Section 2) because of the very low inlet hydrogen temperature to the heat exchangers.

In summary, the comparison studies discussed in this section show the recycle loop system for constant  $T_{it}$  and O/F control to be competitive with the baseline approach, excluding consideration of the performance degradation associated with the use of open-loop control. When an error analysis is applied to the open-loop control concept, the reduction in combustor pressure (necessary to make variations in valve inlet pressures) have only a slight affect on throughflow, and turbine inlet temperature (necessary to make worst-case temperature less than  $2060^{\circ}\text{R}$ ) results in a performance degradation of over 10 percent. The other turbine temperature control concepts were found to be noncompetitive for various reasons. The baseline approach provides closed-loop control of the O/F ratio while the most competitive alternative provides open-loop control of the O/F ratio. Closed-loop control is preferred because of its suitability for pressure modulation control, ability to accomodate variations in inlet pressure and temperature and in flow control valve orifice areas, and in improved performance.

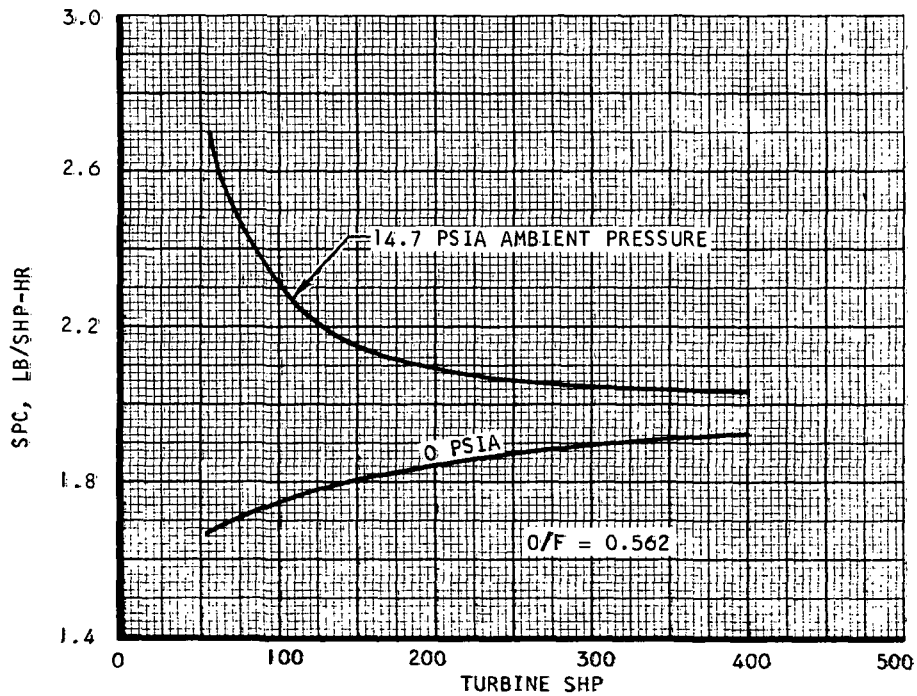
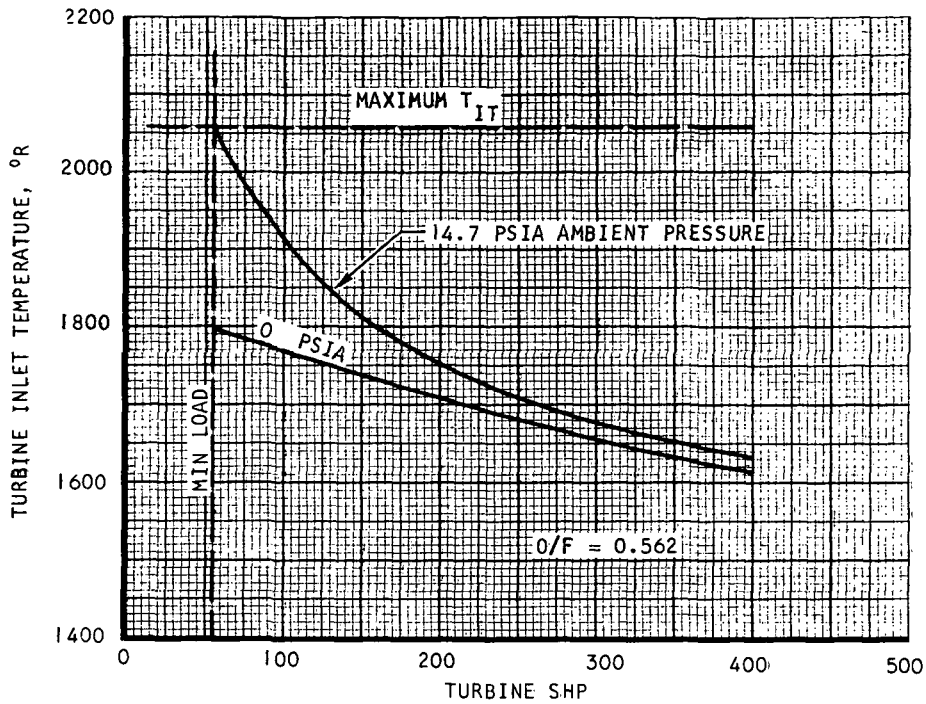

5-66531

Figure 4-10. Variable  $T_{it}$  Constant  $O/F$  Control System Performance

TABLE 4-2  
COMPARISON OF TURBINE INLET TEMPERATURE CONTROL METHODS

Type of Control	Operating Principle	Remarks	T <sub>it</sub> (°R)		O/F		Overall Propellant Consumption	Heat Sink Penalty	Heat Exchanger Design Risk
			Maximum	Minimum	Maximum	Minimum			
Constant T <sub>it</sub> , variable O/F (baseline)	Sense T <sub>it</sub> to modulate oxygen flow	Available control options: 1. Sense T <sub>it</sub> 2. Sense interstage temperature 3. Sense T <sub>egt</sub> , P <sub>amb</sub> , TSHP; calculate T <sub>it</sub>	2060	2060	.736	.56	Minimum	None	Low
Floating T <sub>it</sub> and O/F	T <sub>it</sub> and O/F not directly controlled	Performance sensitive to component tolerances	2060	1180	.56	.37	50 percent penalty	None	Low
Constant T <sub>it</sub> and O/F	Maintain constant hydrogen temperature; O/F control by pressure and temperature equilization	Available cycle options: 1. Recycle 2. Split recuperator 3. Recuperator bypass	2060	2060	.736	.736	2 percent penalty	None	Low
Floating T <sub>it</sub> , constant O/F	Variable T <sub>it</sub> results with varying hydrogen temperature; O/F control by pressure and temperature equilization	-	2060	2060	.825	.825	5 to 6 percent penalty	150 to 200 lb	Moderate
			2060	2060	.835	.835	5 to 6 percent penalty	None	High
			2060	1610	.562	.562	13 to 14 percent penalty	None	Low

## SECTION 5

### HYDROGEN LOOP TEMPERATURE CONTROL

#### INTRODUCTION

As discussed in Section 2 of this volume and summarized in Table 5-1, it is necessary to observe certain temperature limits in providing internal thermal control for the APU. The propellants may enter the system over a wide temperature range (75° to 500°R) and span this range within 2 sec. The baseline system concept uses a recycle loop for hydrogen preheating with a recycle control to maintain hydrogen inlet temperature to the oil coolers at a nominal temperature of 400°R. As indicated in Table 5-1, alternative arrangements are possible; it is apparent from Table 5-1 that all of these will show increased size and weight or other disadvantages relative to the baseline approach, on a component level. On a system level, these alternatives will result in increased SPC (primarily in oxygen consumption) and reduced hydraulic cooling capability.

TABLE 5-1

SUMMARY OF HYDROGEN LOOP TEMPERATURE CONTROL CRITERIA

Parameter	Recuperator Inlet Hydrogen Temperature	Recuperator Hot-gas Side Discharge Temperature	Hydrogen Inlet Temperature to Oil Coolers
Temperature limit	500°R minimum to avoid icing with counterflow recuperator	700°R minimum to avoid condensation in turbine exhaust gas	400°R minimum to avoid oil congealing problems
Baseline system provisions	Locate recuperator downstream of other heat loads	Size recuperator for minimum discharge temperature = 700°R at maximum hydrogen flow	Recycle loop for hydrogen preheating
Alternative provisions	Use parallel flow recuperator	Recuperator bypass	Buffered design for lowered inlet temperatures
Disadvantages of alternative	Increased recuperator size and weight	Additional control function required	Increased size, weight, and difficulty of fabrication

## HYDROGEN LOOP ARRANGEMENTS

Figure 5-1 shows the baseline hydrogen loop arrangement and two alternative arrangements. The baseline arrangement uses a recycle loop while the alternative arrangements place the heat exchangers in series with appropriate bypass valves to provide proper inlet hydrogen temperatures for the various heat loads.

### Baseline Hydrogen Loop Arrangement

The recycle loop used in the baseline concept provides recycling of hydrogen representing 50 to 94 percent of the inlet hydrogen flow. Clearly, a fan pump, or jet pump will be required to recirculate the hydrogen flow to make up the pressure losses in the heat exchangers and ducting, which will range from approximately 0.2 psi at minimum power to approximately 10 psi at full output for the heat exchanger designs selected. Considering that the hydrogen loop operates at a nominal pressure in the 450 to 500 psia range, these pressure losses represent a very small pressure ratio for the pumping device. Clearly, electric-motor-driven fans or pumps can be used for flow recycling. However, this application is ideal for a jet pump, which has flow-pressure rise characteristics that tend to match the characteristics required for the present application. That is, with an increase in the primary hydrogen flow, the jet pump becomes more efficient and provides increased pressure rise with increased secondary flow. Electric-motor-driven fans and pumps, on the other hand, tend to have relatively constant flow- $\Delta P$  characteristic and, as consequence, would require essentially constant input power.

Figure 5-2 shows the recycle flow ratio required to maintain a 400°R mixed-hydrogen temperature. Also shown is the performance capability of a jet pump that is sized to deliver the required flow at the maximum pressure drop. It will be noted that the jet pump has an increasing margin of pumping capability at reduced loads. Figure 5-3 compares the jet pump pressure rise with the hydrogen loop pressure drop as a function of turbine output power. The increased pumping at high loads is obtained with increased pressure drop across the jet pump primary nozzle.

Analysis of jet pump performance in the cycle requires a sophisticated computer program of the type developed for the present program plus considerable experience in accurately predicting jet pump performance. The jet pump state of the art is well developed at AiResearch and has been successfully applied to numerous aircraft air cycle systems and space environmental control systems. Therefore, the jet pump is recommended for this system because it is a passive device with intrinsic performance characteristics that efficiently match pumping capability to the load. In fact, it will be shown elsewhere in this section that an active temperature control is not required for the jet pump recirculation loop if the inlet hydrogen temperature does not vary over too wide a range.

### Alternative Hydrogen Loop Arrangements

With the alternative hydrogen loop arrangements shown in Figures 5-1a and 5-1b, the recuperator is located upstream from the hydraulic cooler and the

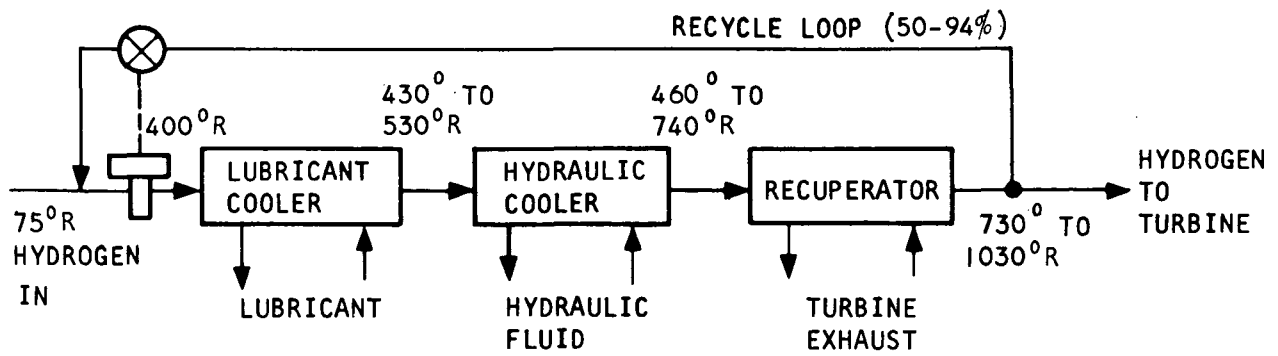

a. BASELINE

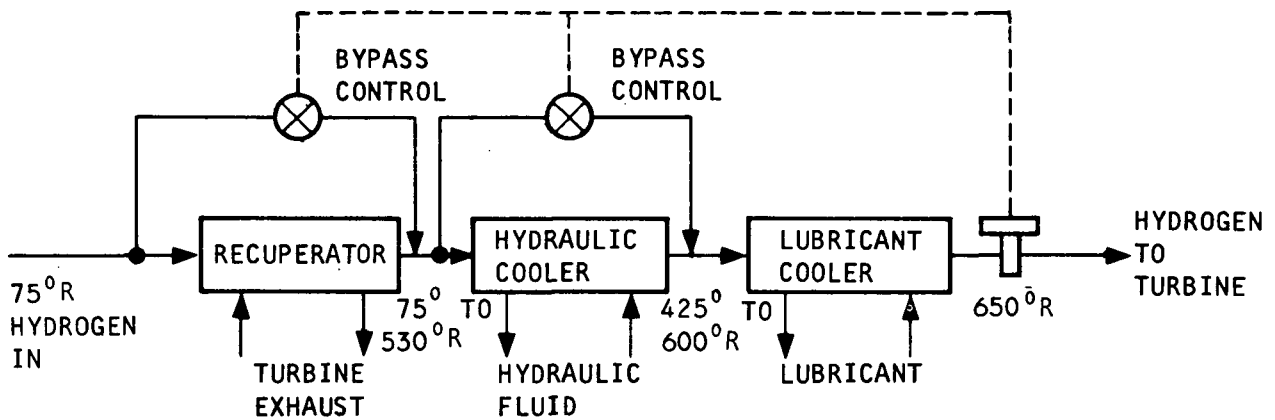

b. ALTERNATIVE NO. 1

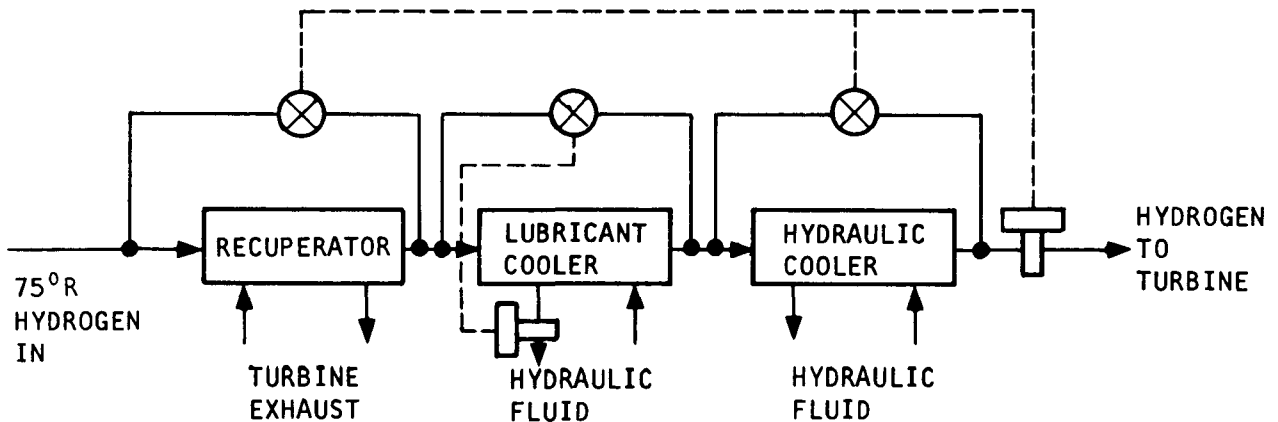

c. ALTERNATIVE NO. 2

S-66998

Figure 5-1. Baseline and Alternative Hydrogen Loop Arrangements

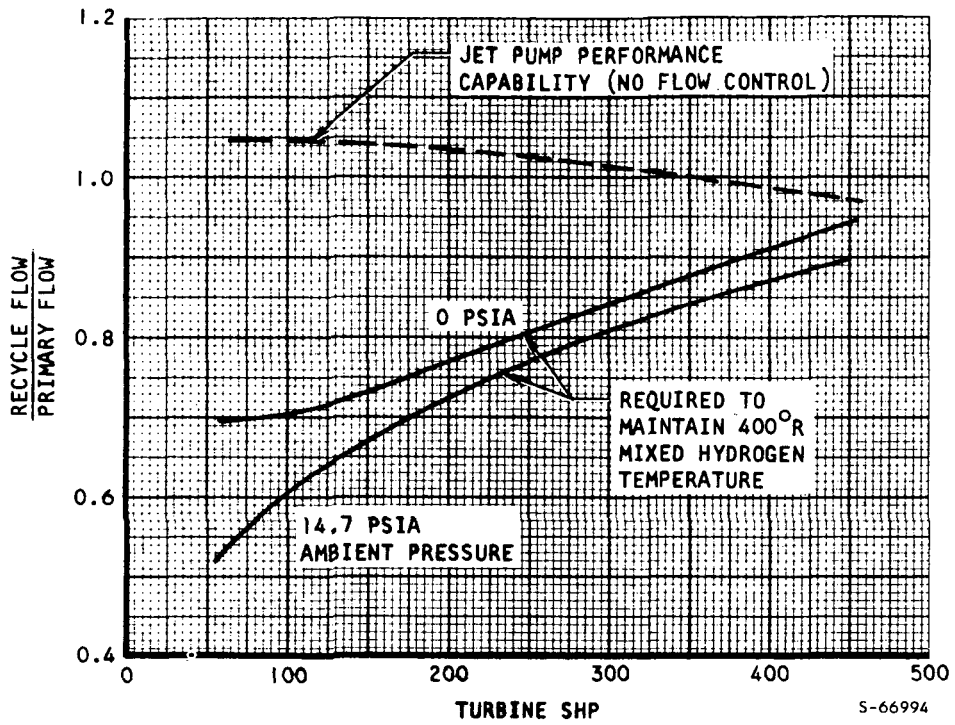

Figure 5-2. Recycle Flow Ratio Requirement for 75°R Hydrogen Inlet Inlet Temperature

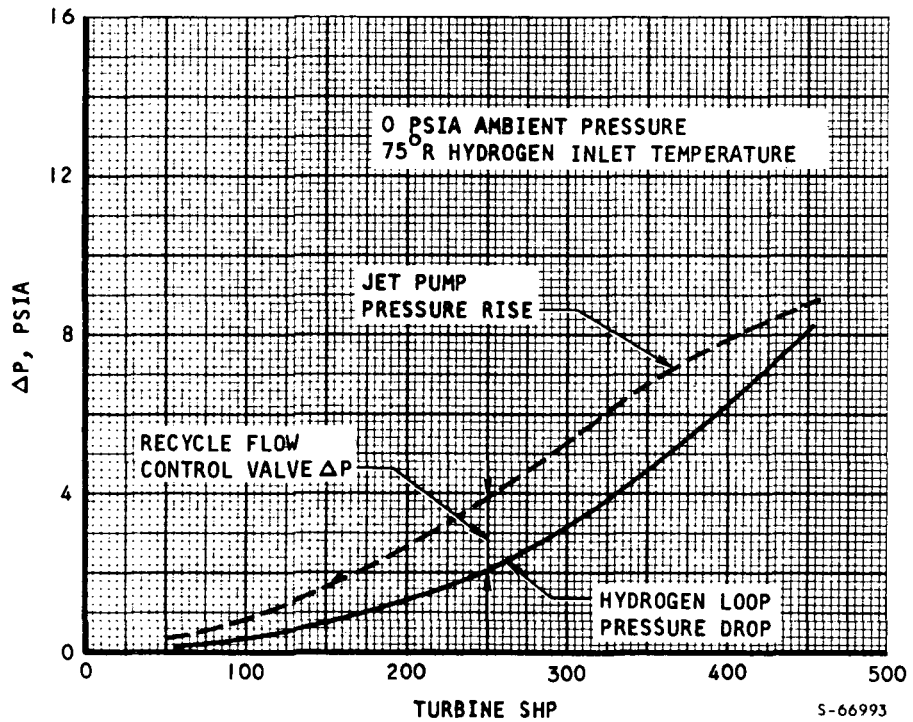

Figure 5-3. Recycle Flow ΔP for 75°R Hydrogen Inlet Temperature

lubricant cooler. Of these two arrangements, alternative No. 1 is preferable because it requires one less control function. In this system, the recuperator bypass control modulates bypass flow to maintain discharge hydrogen temperature constant at 650°R. A hydraulic heat exchanger bypass is also required to permit lubricant cooling at elevated hydraulic fluid temperatures. As mentioned previously in Section 2, these arrangements require full bypass at minimum APU output power, thereby exposing the hydraulic heat exchanger to very low inlet temperatures. As also discussed in Section 2, this will lead to fluid congealment in a conventional heat exchanger design. It appears that it may be possible to overcome this low-temperature problem with a buffered heat exchanger design. However, experience with buffered designs is limited to plate-fin surfaces that are not suitable for the high operating pressures (3000 to 4000 psia) required for the hydraulic heat exchanger. No experience exists with buffered shell-and-tube heat exchanger designs and fabrication of heat exchangers of this type appears to offer difficult problems.

The low inlet temperature to the recuperator can, in theory, be accommodated by use of a parallel-flow heat exchanger design to maintain heat exchanger wall temperature above the condensation temperature for the steam in the turbine exhaust gas. However, AiResearch experience with a somewhat comparable design in the Dyna-Soar program indicates that very careful design and extensive testing are required to insure proper flow distribution and avoidance of cold spots within the heat exchanger under all possible operating conditions.

The downstream location of the temperature control sensor represents another potential problem area for this system. AiResearch transient-state heat exchanger studies indicate that temperature changes will be damped out by the heat exchangers. For example, if the system is set for operation with 500°R inlet hydrogen that drops in temperature to 75°R, there will be considerable lag in response since the heat exchangers will tend to hold the discharge temperature at the lubricant oil temperature. Under these conditions, the lubricant cooler could be exposed to low inlet temperatures, requiring use of a low-temperature buffered design similar to that needed for the hydraulic fluid heat exchanger.

In summary, because of the low-temperature problems with the two oil coolers, the need for two temperature control functions, and exposure of the recuperator to low inlet hydrogen temperature (which will require additional development for that unit), neither of the two alternative hydrogen loop arrangements is recommended. It should be emphasized that the baseline approach by use of a recycle loop to preheat the inlet hydrogen avoids all of these potential heat exchanger problems. In other words, no incentive is seen for accepting the heat exchanger development risk with the alternative hydrogen loop arrangements.

## RECYCLE FLOW CONTROL

As indicated previously, the jet pump provides intrinsic flow characteristics that tend to match recycle flow to that needed to preheat the inlet

hydrogen to a relatively constant temperature. The paragraphs following discuss the performance characteristics of the system with and without a recycle flow control.

#### Performance at 75°R Hydrogen Inlet Temperature

Figure 5-4 shows the hydrogen temperature levels obtained in the cycle as a function of output power and ambient pressure for the baseline system with a recycle flow control valve. At low power levels, the hydrogen exit temperature from the lube oil cooler increases as a result of the relationships between lube oil heat load and hydrogen flow. In this system arrangement, the jet pump is sized to provide the necessary recycle flow for the pressure drop and flows obtained under maximum load conditions (sea level ambient pressure). At part load, the jet pump must deliver a lower pressure rise to circulate the required flow so that a recycle flow control valve is used to limit the recycle flow.

If the recycle flow control function is eliminated, more hot gas will be recycled at part load and the hydrogen inlet temperature to the lube oil cooler will increase. This is illustrated in Figure 5-5. In this case, the hydrogen inlet temperature to the lube oil cooler increases from 400° to 460°R at minimum load by eliminating the recycle flow control. At the same time, the hydrogen temperature to the hydraulic fluid cooler increases from 530° to 575°R at minimum load. As a consequence, for a given hydraulic fluid temperature, the available heat sink capacity for hydraulic cooling is reduced by elimination of the recycle flow control. Another effect is a 10° to 40°F reduction in recuperator outlet temperature, which results in a slight increase in propellant consumption. The reduction in hydraulic cooling capacity is perhaps the most significant effect. As mentioned previously, it is not possible to evaluate this factor in this study. Elimination of the recycle flow control is recommended for systems where the hydrogen will be supplied at relatively constant temperature, such as the low-pressure cryogenic liquid-supplied systems. For the gaseous supplied systems, the inlet temperature probably varies over an excessively wide range (specified to be 75° to 500°R in the APU study guidelines).

#### Performance at 300°R Hydrogen Inlet Temperature

Figure 5-6 shows the temperature levels obtained in the system where the propellants are supplied at 300°R. In this case, the lube oil heat exchanger inlet temperature range is 540° to 650°R. Sufficient cooling capacity is available to meet the lube oil cooling requirement within a maximum temperature of 750°R for the lubricant. However, it will be noted that no hydraulic cooling capacity is available below a hydraulic fluid temperature of 715°R at a minimum load. Hydraulic cooling capacity can be increased by (a) use of a recycle flow control valve or (b) redesign of the jet pump for different flow- $\Delta P$  characteristics.

Figure 5-7 shows the temperature levels in the system for 300°R propellants with a recycle flow control. A significant reduction in temperature is obtained where the recycle flow control valve maintains a 400°R hydrogen

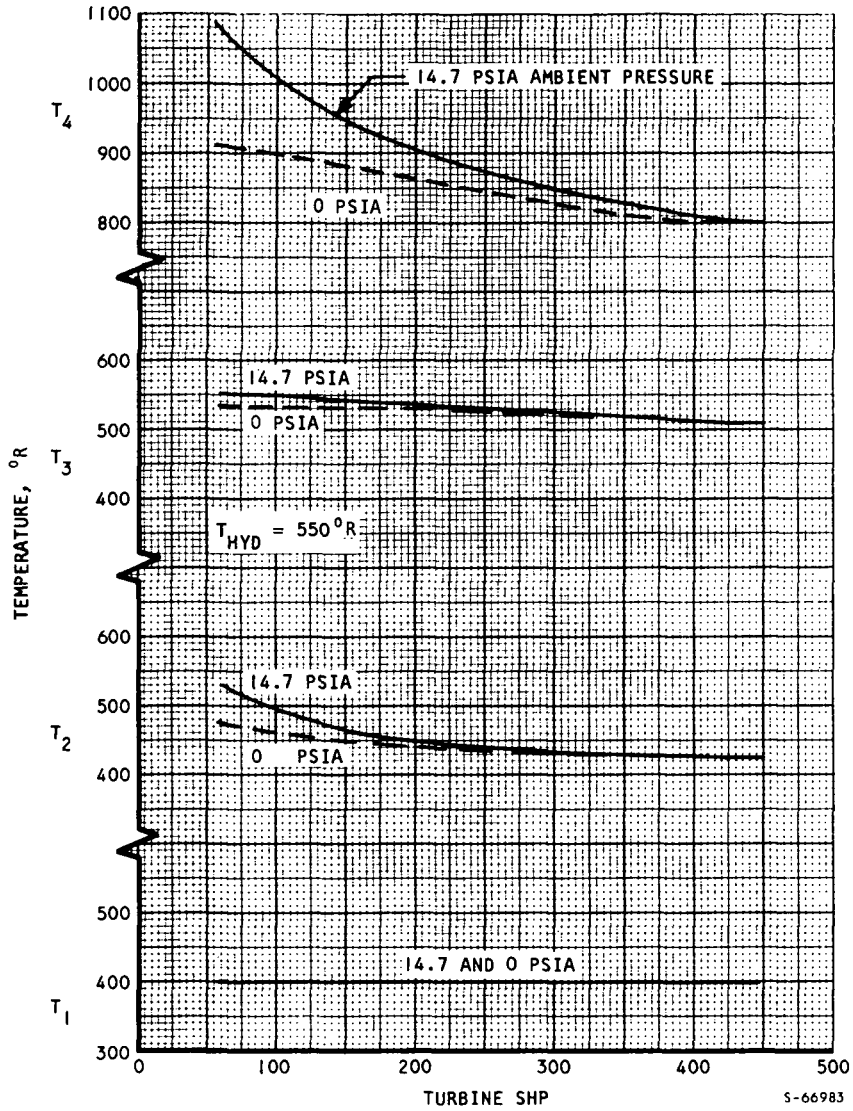
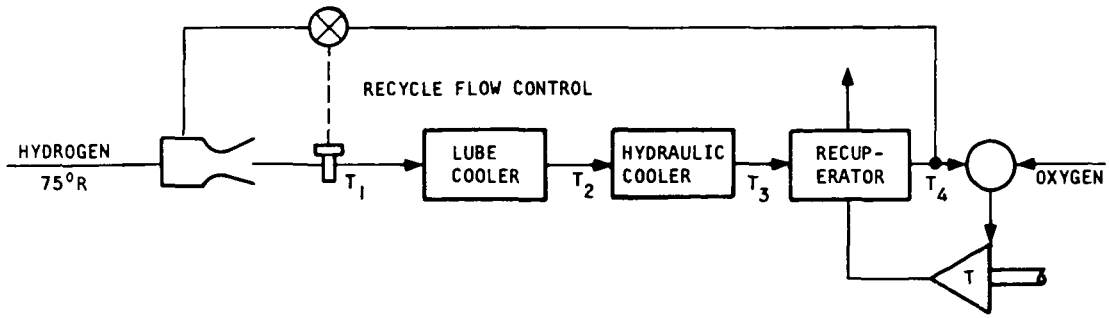

Figure 5-4. Hydrogen Loop Temperature Levels with Recycle Flow Control and 75°R Inlet Hydrogen Temperature

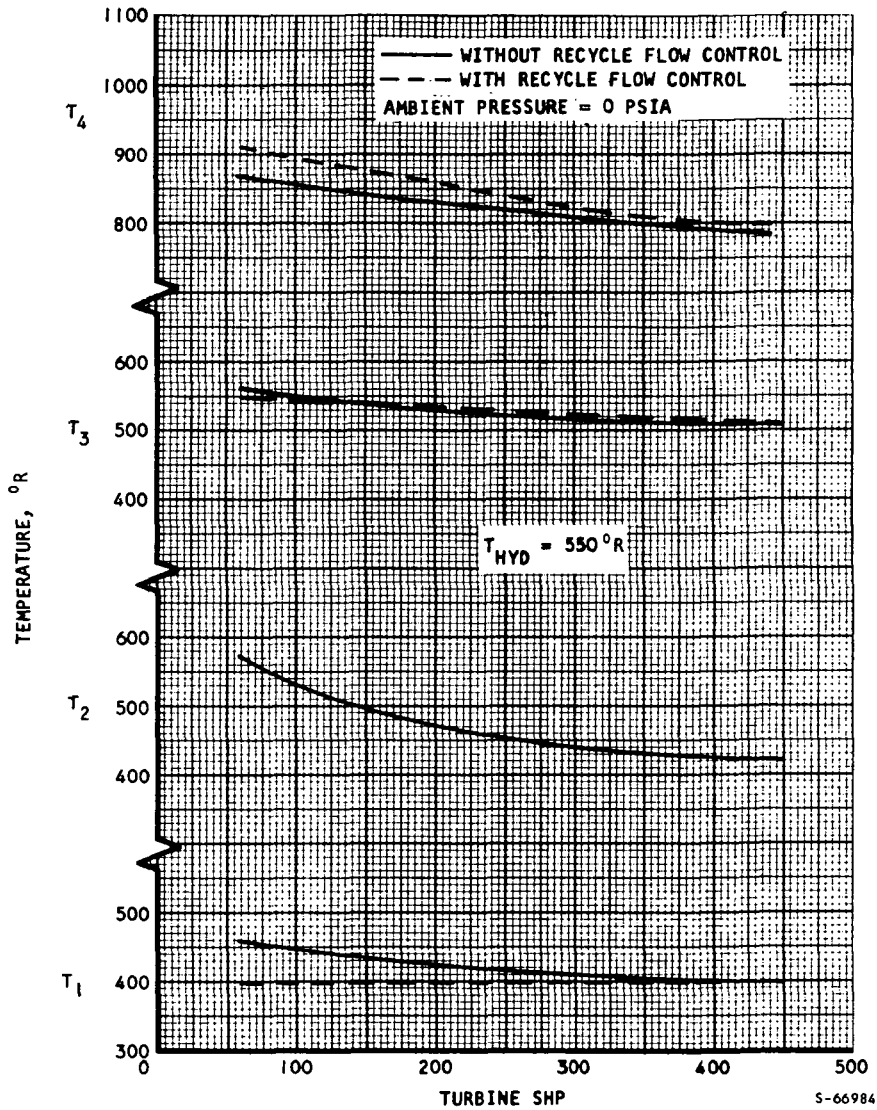
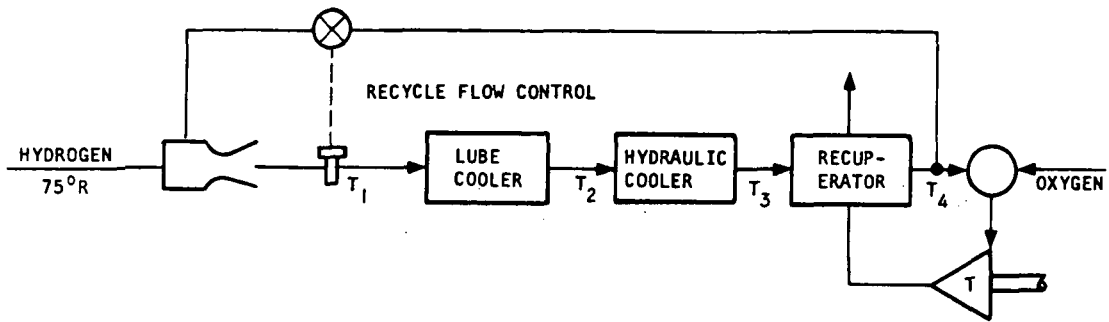

Figure 5-5. Comparison of Hydrogen Loop Performance with and without Recycle Flow Control at 75°R Hydrogen Inlet Temperature

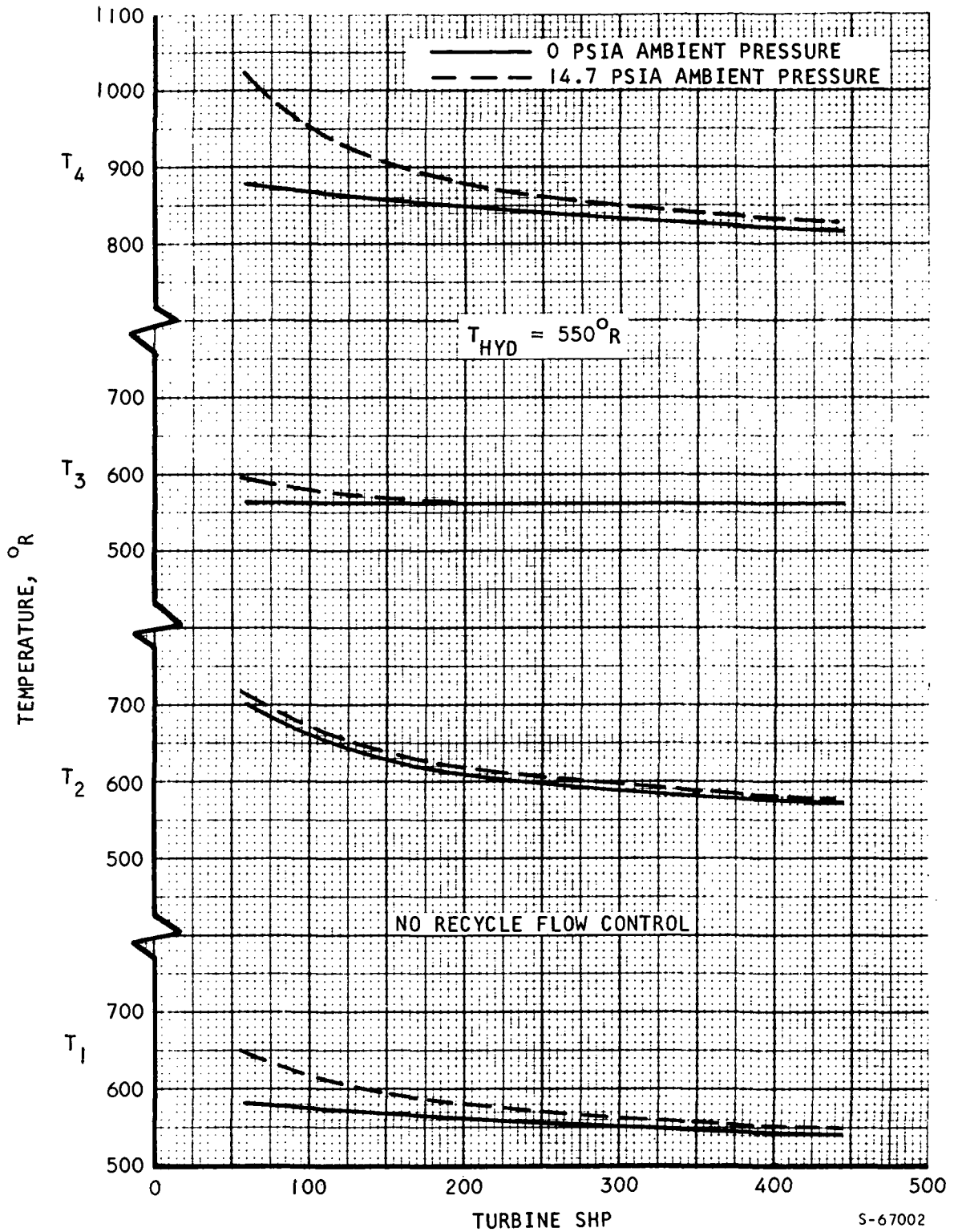

Figure 5-6. Hydrogen Loop Performance for 300°R Hydrogen Inlet Temperature without Recycle Flow Control

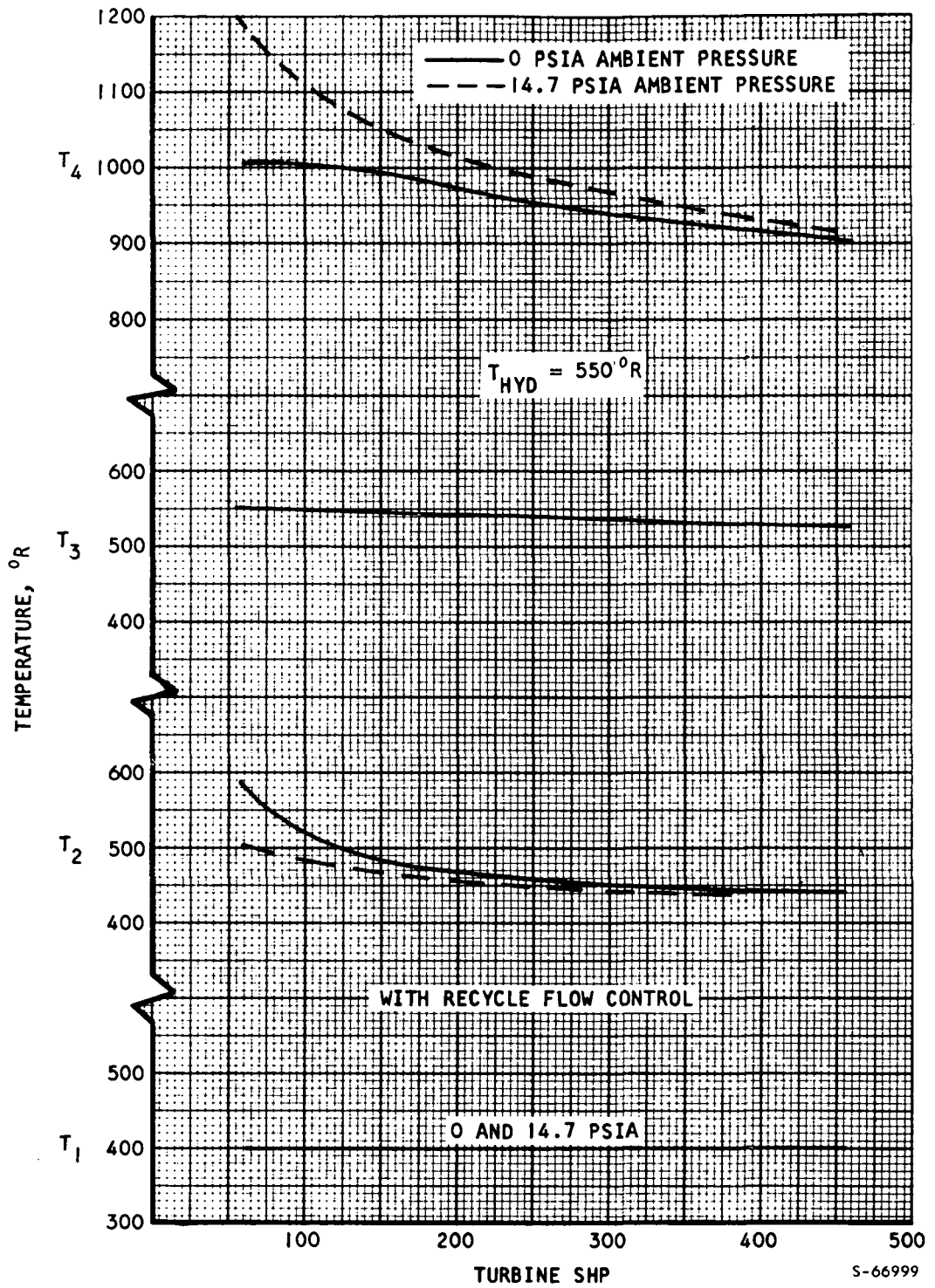

Figure 5-7. Hydrogen Loop Temperature Levels with Recycle Flow Control and 300°R Inlet Hydrogen Temperature

temperature into the lube oil cooler. For example, the hydrogen inlet temperature to the hydraulic cooler is reduced by 100° to 200°F. Use of the recycle valve will also lead to a 100° to 200°F increase in recuperator hydrogen outlet temperature, which will reduce SPC.

From the foregoing discussion, it is apparent that the recycle valve will improve performance. The improvement in available hydraulic heat sink is illustrated in Figure 5-8 for a hydraulic fluid temperature of 550°R and a hydrogen supply temperature of 300°R. For this case, heat will be added to the hydraulic fluid under all conditions for the system without recycle flow control. With recycle flow control, heat sink capacity is available for nearly all operating conditions. The available heat sink capacity increases with increasing temperature. For steady-state operation, the hydraulic system will tend to approach an equilibrium temperature where the heat sink capacity is sufficient to reject the waste heat load. It can be concluded that the hydraulic system equilibrium temperature will be significantly higher with no recycle control.

#### Effect of Recycle Control on Propellant Consumption

As shown in Figure 5-9, the propellant consumption of a system with recycle control will be 2 to 4 percent less than that of a system without recycle control.

#### CONCLUSIONS

The baseline hydrogen loop concept using recycle flow control avoids low-temperature problems obtained in the heat exchangers with other arrangements. The jet pump provides an efficient static means of flow recycling in which the pumping capability increases with flow to match the increased pressure drop obtained in the heat exchangers. For systems operating with essentially constant inlet hydrogen temperatures, the recycle flow control valve can be eliminated and the hydrogen loop becomes purely passive.

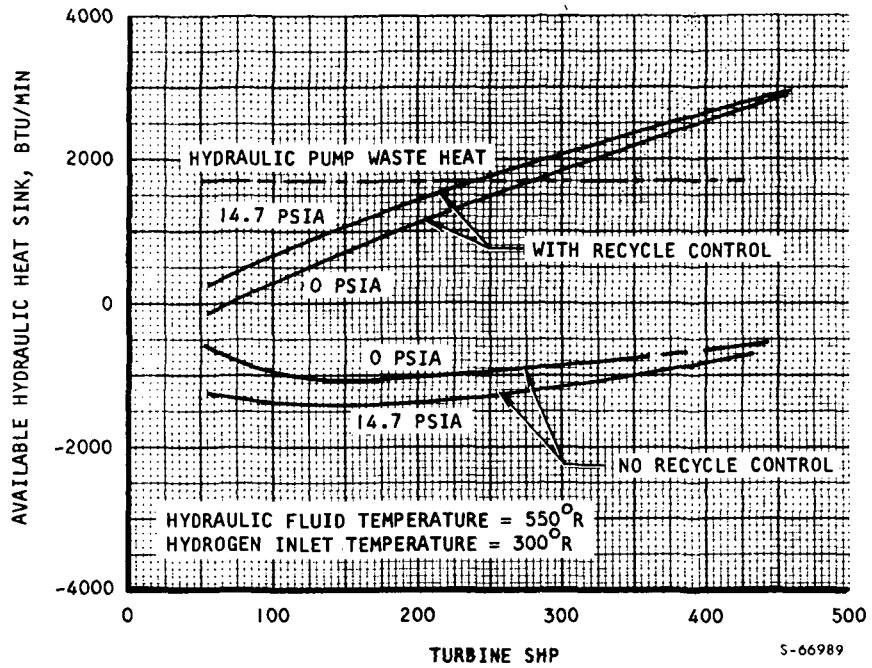

Figure 5-8. Available Hydraulic Heat Sink with and without Recycle Flow Control

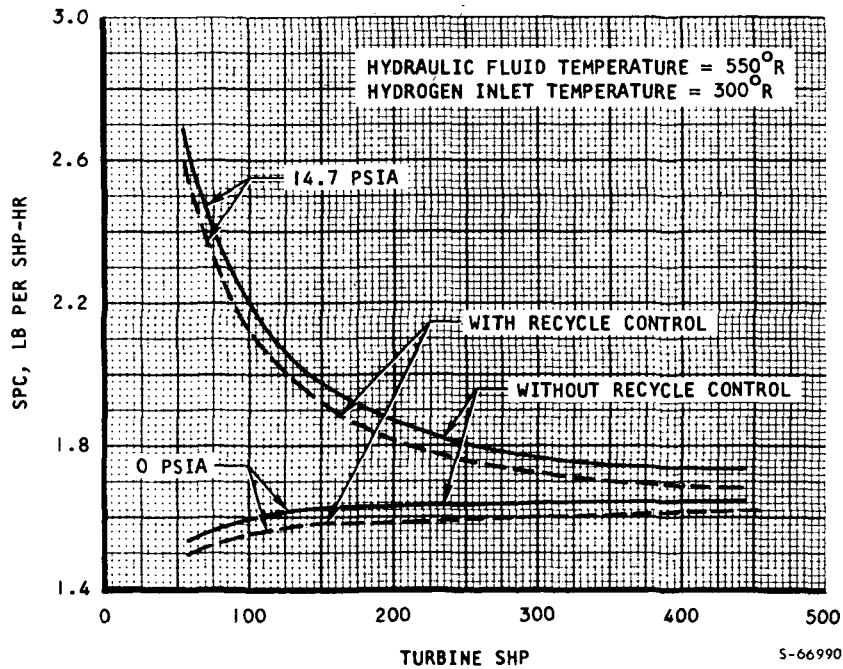

Figure 5-9. Specific Propellant Consumption with and without Recycle Flow Control

## SECTION 6

### HYDRAULIC THERMAL CONTROL

#### INTRODUCTION

As mentioned previously, the heat transferred to the hydrogen flow in the APU hydraulic fluid coolers depends upon the temperature level of the hydraulic fluid, the hydrogen flow, and the hydraulic fluid flow. Hydraulic cooling capacity can be modulated by means of a temperature-control bypass. In the proposed system design, this bypass is not required. If excessive cooling capacity is available for a given operating condition, the temperature of the hydraulic fluid will seek a low operating level where an equilibrium heat balance (heat absorbed by hydrogen = waste heat produced in the hydraulic system) will be obtained. Thermal inertia of the hydraulic system (hydraulic fluid + metal parts in thermal contact with the hydraulic fluid) is large, and, as a consequence, the rate of change in hydraulic fluid temperature will be low. The baseline system concept has the capability of supplying substantial hydraulic cooling in excess of the pump heat load. Therefore, it has considerable flexibility in providing passive thermal control for the hydraulic fluid and in accommodating undefined hydraulic system heat loads at no performance penalty to the APU system. The proposed system concept should be credited with this hydraulic cooling capability, as compared with other systems that have limited cooling capability and therefore will require additional heat sink expendables (water or hydrogen) to provide the necessary supplemental cooling.

#### STEADY-STATE PERFORMANCE

Steady-state hydraulic cooling performance will be given as a function of turbine output power, hydraulic fluid temperature, and ambient pressure for two inlet hydrogen conditions, 75°R and 300°R. These parametric studies utilized the steady-state performance program for the baseline APU system configuration in which the hydrogen recycle flow is regulated to maintain an inlet hydrogen temperature of 400°R to the oil coolers. Figure 6-1 shows the assumed relationships between hydraulic flow and turbine output power.

#### 300°R Hydrogen Inlet Temperature

Figure 6-2 shows the obtainable hydraulic cooling as a function of turbine output and hydraulic fluid temperature for space and sea level ambient pressures with a hydrogen inlet temperature of 300°R. For a given average heat input to the hydraulic system, the hydraulic fluid will approach an equilibrium temperature determined by the average turbine power level. The time required to reach the equilibrium temperature will be determined by the thermal capacity of the system and the other heat transfer paths for loss or addition of heat to the hydraulic fluid flow. Because of the variable conditions of output power and ambient pressure during a Space Shuttle vehicle mission,

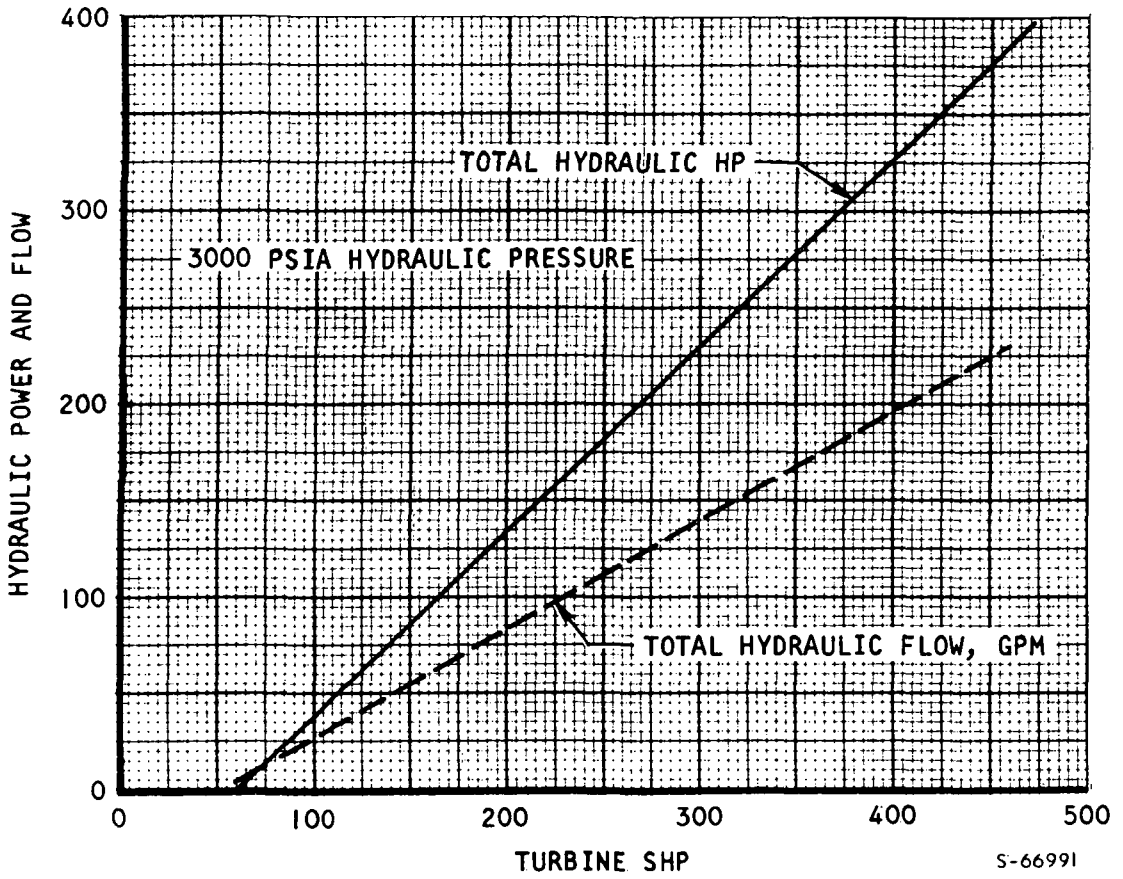

Figure 6-1. Assumed Relationships between Hydraulic Output and Turbine Output Power

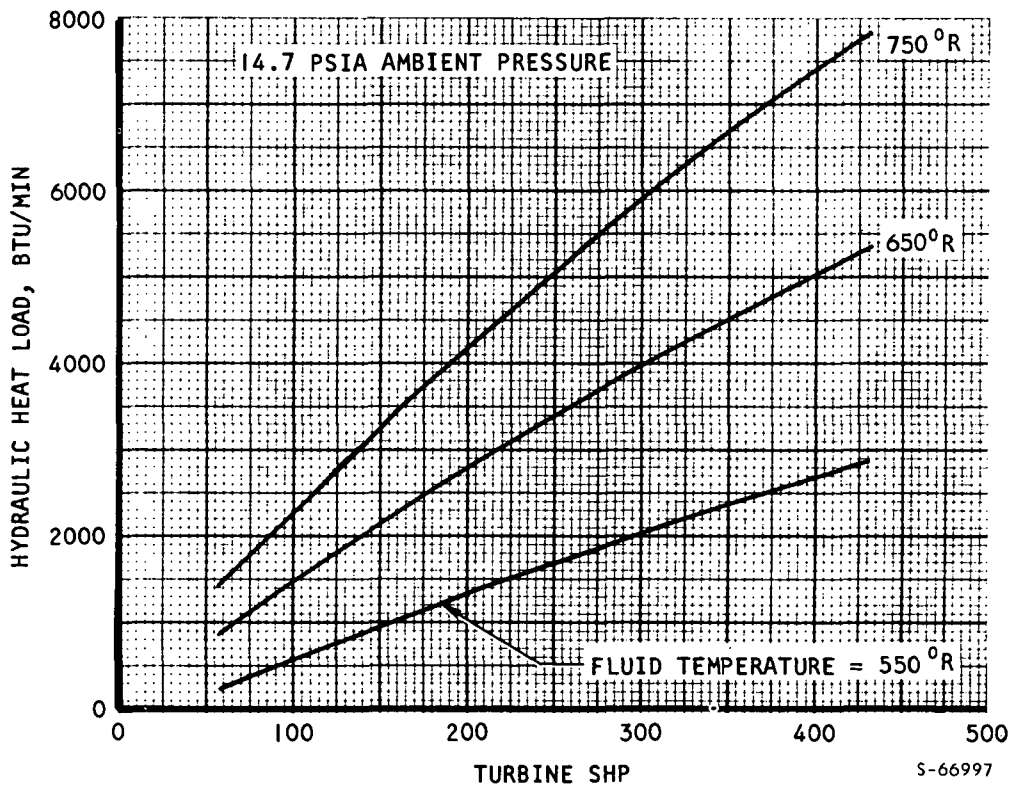
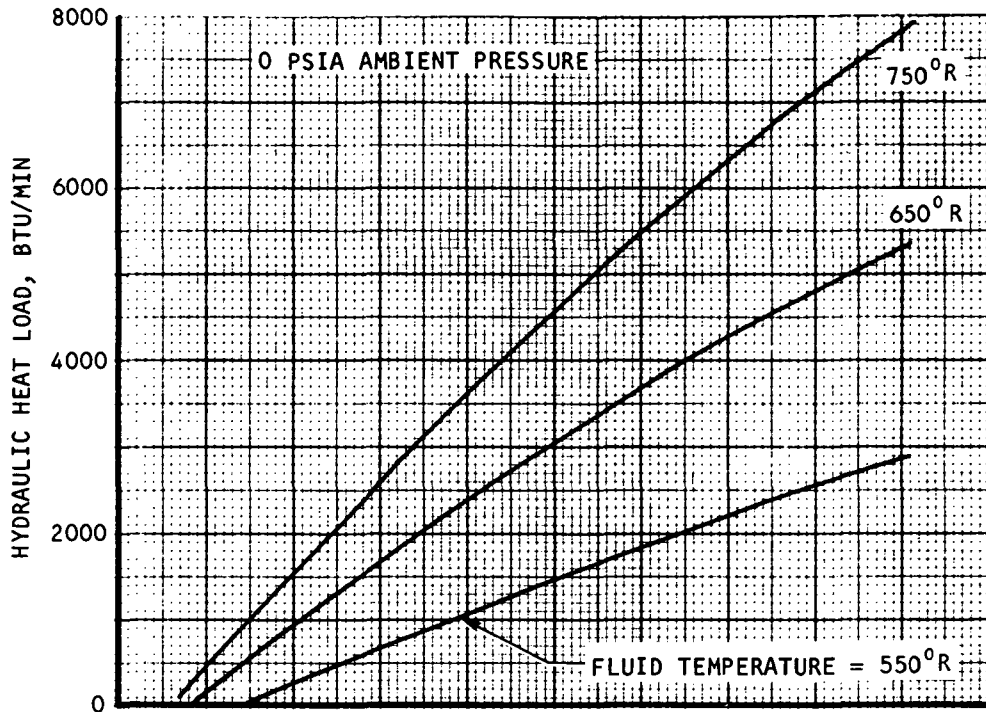

Figure 6-2. Hydraulic Cooling Capacity for 300°R Inlet Hydrogen Temperature

equilibrium conditions may never be attained. However, the equilibrium temperature concept is useful in system studies to insure the adequacy of the thermal design of the system.

Figure 6-3 shows the effects of varying hydraulic fluid temperature on overall cycle performance in terms of the SPC and O/F ratio obtained at space and sea level ambient pressures as a function of turbine output power. With increasing hydraulic fluid temperature, both SPC and O/F ratio decrease, reflecting an increasing hydraulic heat input into the cycle.

Figure 6-4 shows the hydraulic fluid equilibrium temperature for the case where the hydraulic system heat load is equal to the pump losses. In this case, for the hydraulic fluid temperature to be under the maximum allowable limit of 750°R at equilibrium, the APU must have an average output of 67 shp at sea level and 109 shp in space. If the hydraulic pumps are unloaded to 1000 psi, the thermal problem is considerably more severe. It can be concluded from this analysis that available APU hydraulic cooling is probably not adequate under these conditions and that supplemental cooling will be required for the hydraulic system. Of course, these supplemental cooling provisions could be conveniently incorporated into the APU as described in the Phase I studies presented in Volume II.

Figure 6-5, for example, shows the effect on cycle performance (by reducing O/F ratio) of maximizing hydraulic waste heat input to the cycle (in this case, by increasing hydraulic fluid temperature). The simple correlation shown in Figure 6-5 gives O/F ratios within 2 percent of the precisely calculated values given by the steady-state program.

### 75°R Inlet Hydrogen Temperature

If the hydrogen is supplied to the APU at a lower temperature, additional cooling capacity will be available at a given hydraulic fluid temperature. Figures 6-6 and 6-7 show the hydraulic cooling and resulting cycle performance for a hydrogen supply temperature of 75°R. Figure 6-8 gives the equilibrium temperature for the hydraulic pump loss heat load. In this case, to maintain the equilibrium temperature below 750°R, the APU power output must exceed 51 shp at sea level and 81 shp in space. In this case, sufficient cooling capacity appears to be available with a reasonable design margin. It should be noted that if high APU output power is required for sustained periods, it may be necessary to add a temperature control to the hydraulic heat exchanger to maintain the fluid temperature at a desired level for optimum hydraulic system performance. Figure 6-9 shows the effect of hydraulic fluid temperature on system performance in the form of a correction factor to be applied to the O/F ratio calculated for a 550°R hydraulic fluid temperature.

### TRANSIENT-STATE PERFORMANCE

As indicated previously, ability of the system to absorb heat from the hydraulic fluid depends upon the temperature of the hydraulic fluid (in addition to the other factors that determine propellant flow). Any deficiency in hydraulic cooling capacity relative to the hydraulic heat load results in an increase in hydraulic fluid temperature to an equilibrium level where a heat

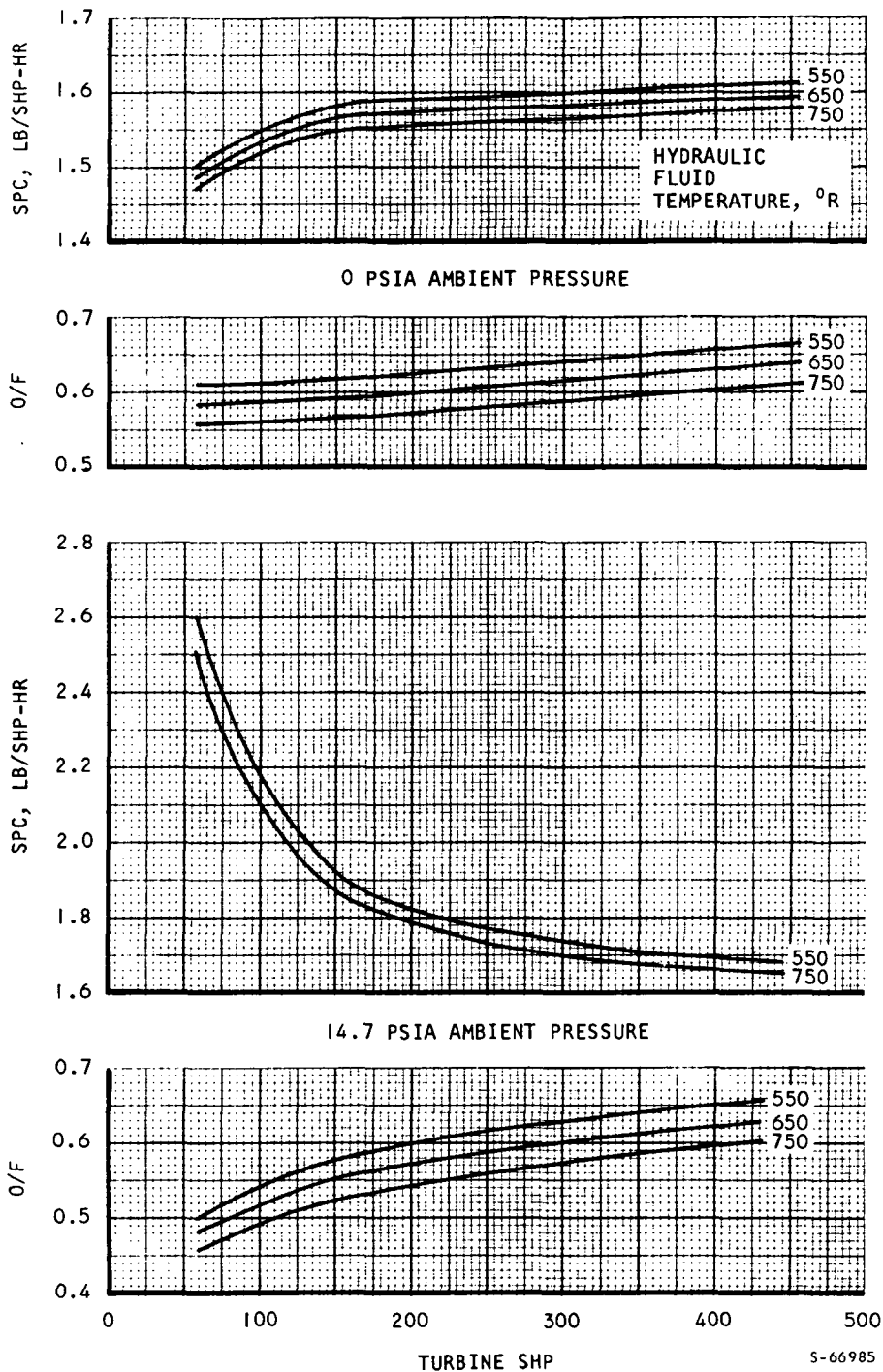

Figure 6-3. APU System Performance with 300°R Inlet Hydrogen Temperature and Varying Hydraulic Fluid Temperature

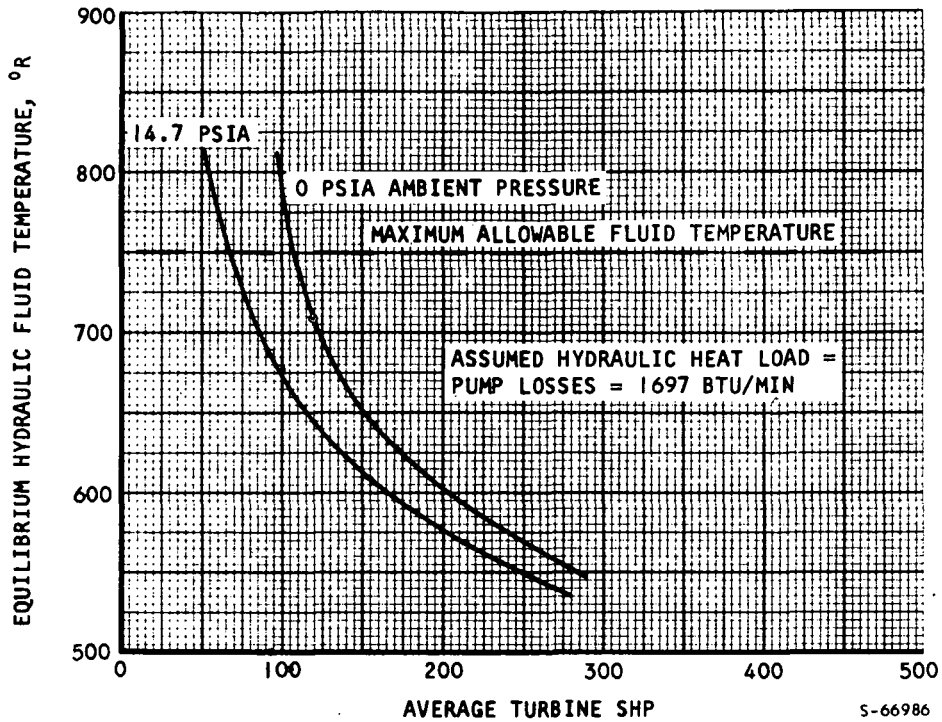

Figure 6-4. Equilibrium Hydraulic Fluid Temperature for 300°R Inlet Hydrogen Temperature

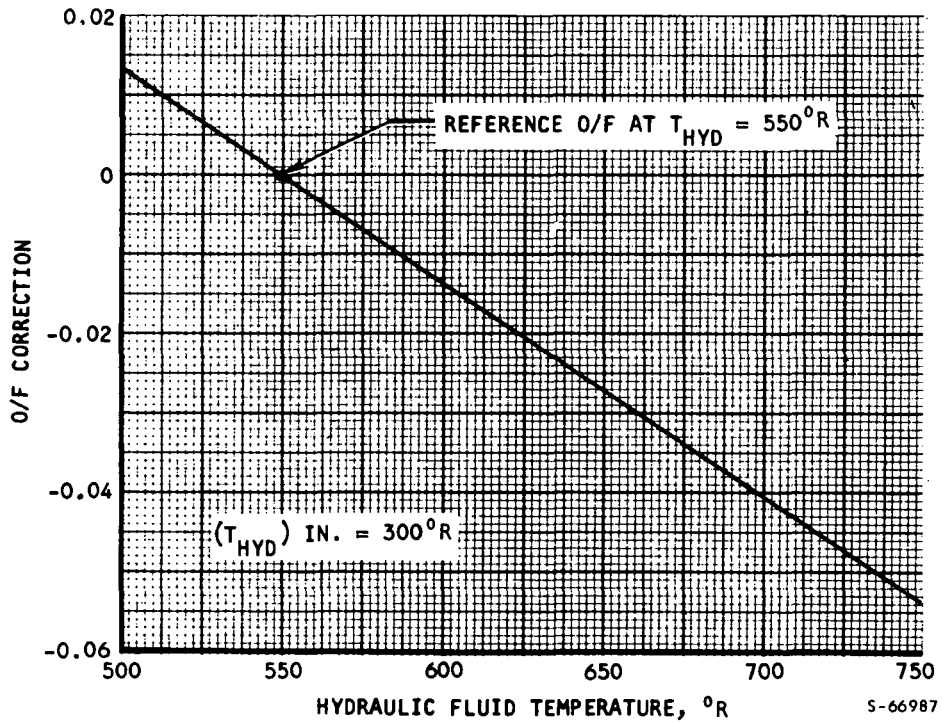

Figure 6-5. O/F Correction for Hydraulic Fluid Temperature Variation and 300°R Inlet Hydrogen Temperature

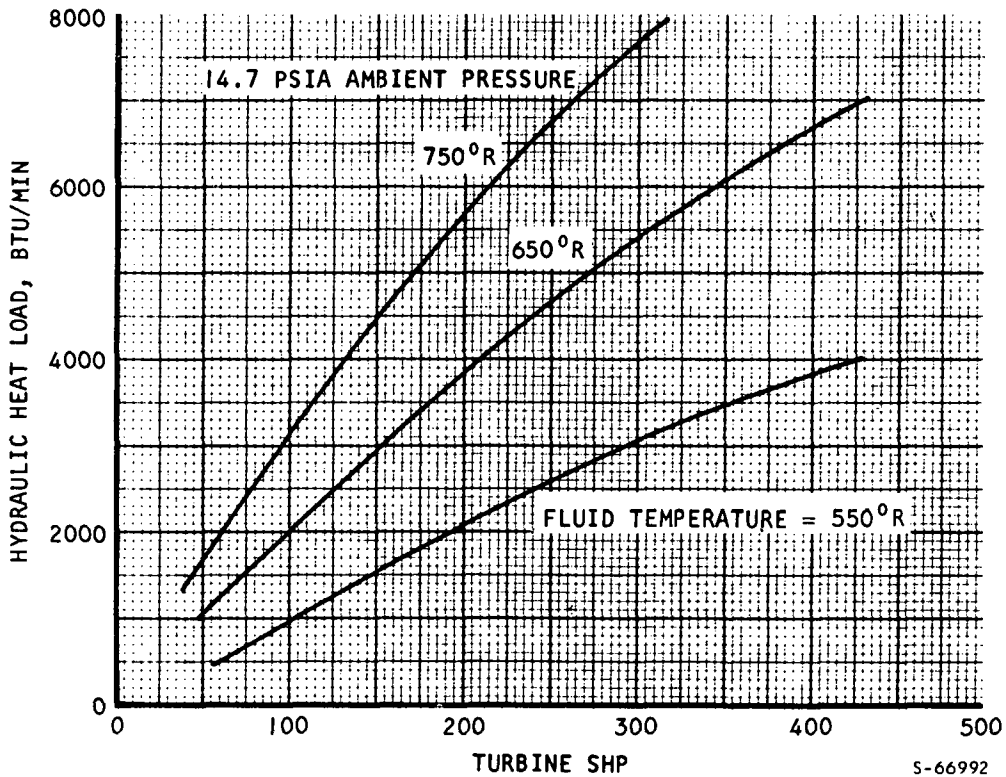
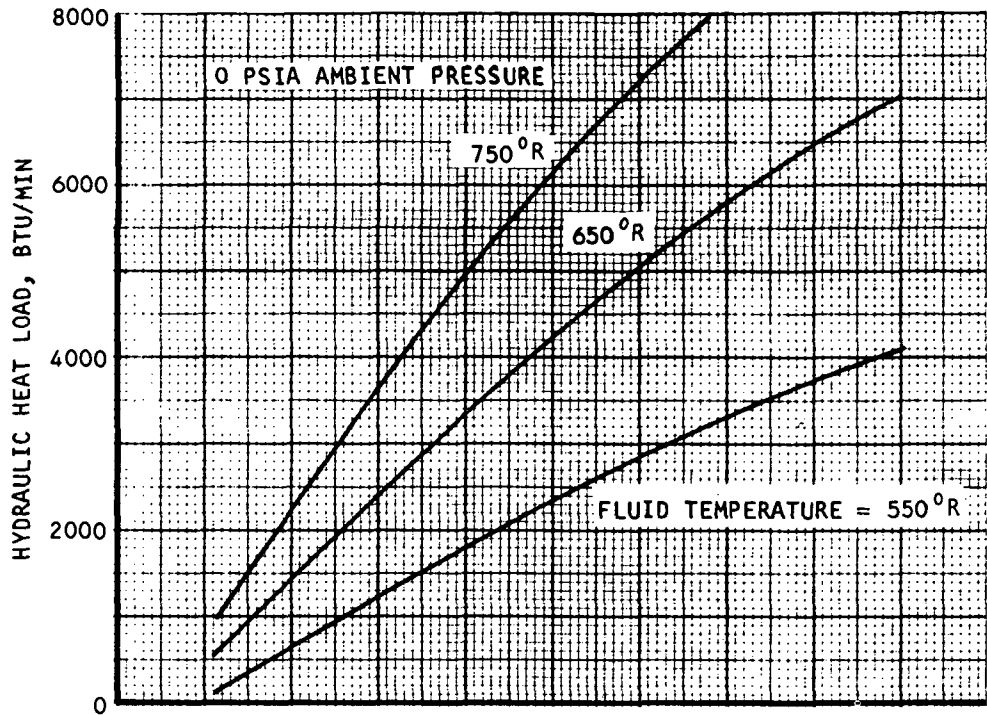
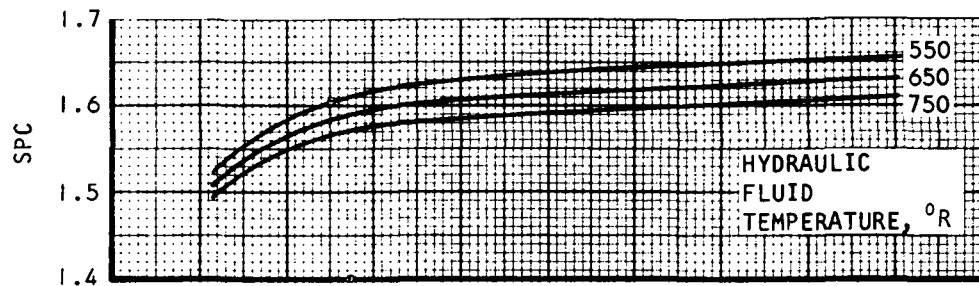
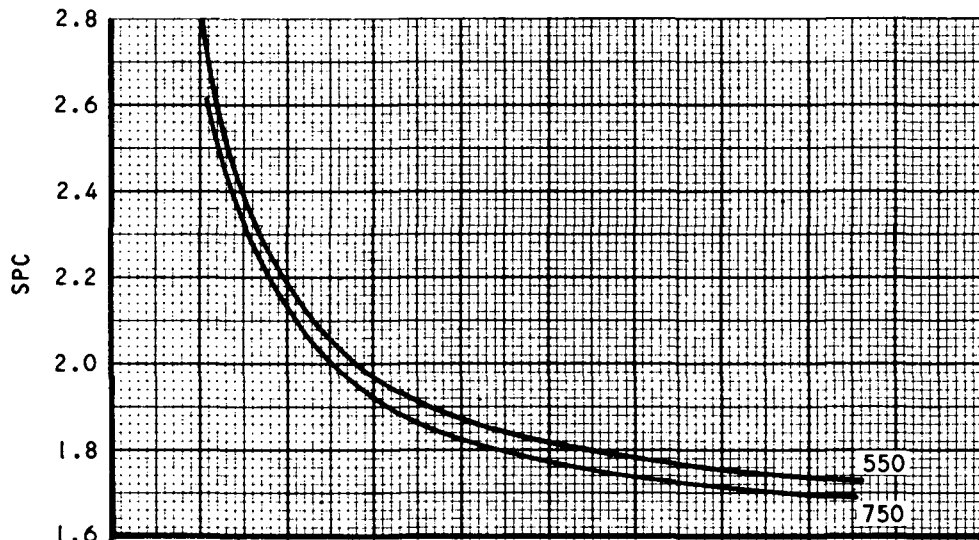
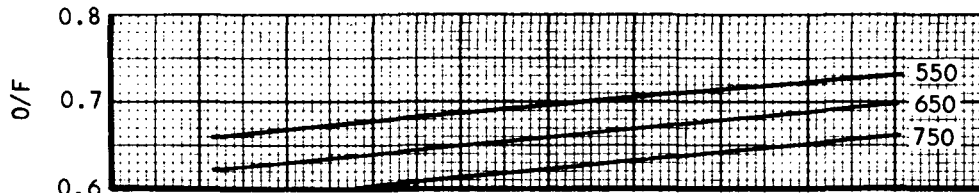

Figure 6-6. Hydraulic Cooling Capacity for 75°R Inlet Hydrogen Temperature



0 PSIA AMBIENT PRESSURE



14.7 PSIA AMBIENT PRESSURE

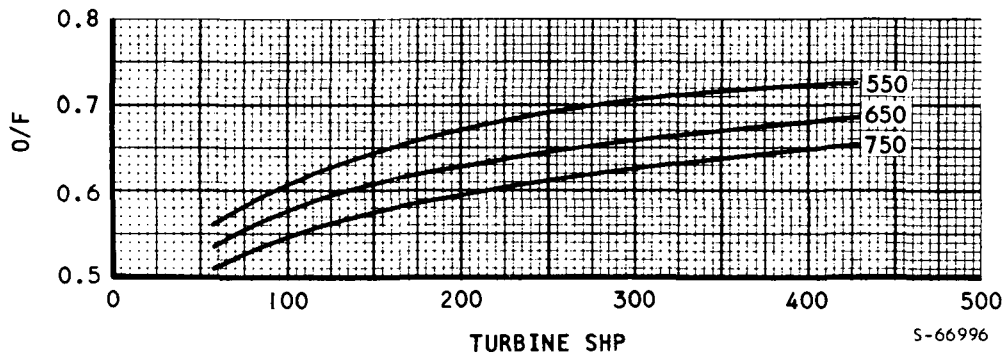

TURBINE SHP

S-66996

Figure 6-7. APU System with 75°R Inlet Hydrogen Temperature and Varying Hydraulic Fluid Temperature

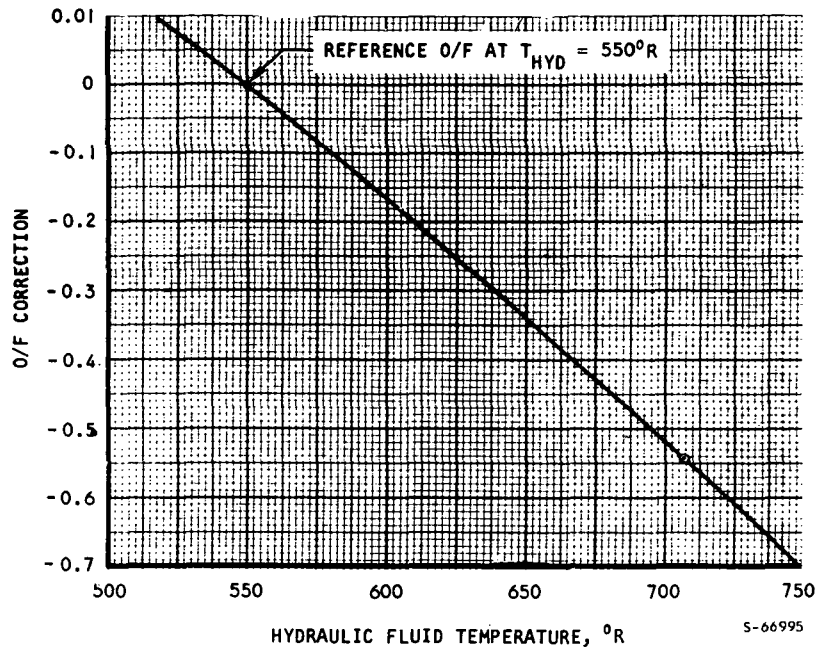

Figure 6-8. Equilibrium Hydraulic Fluid Temperature for 75°R Inlet Hydrogen Temperature

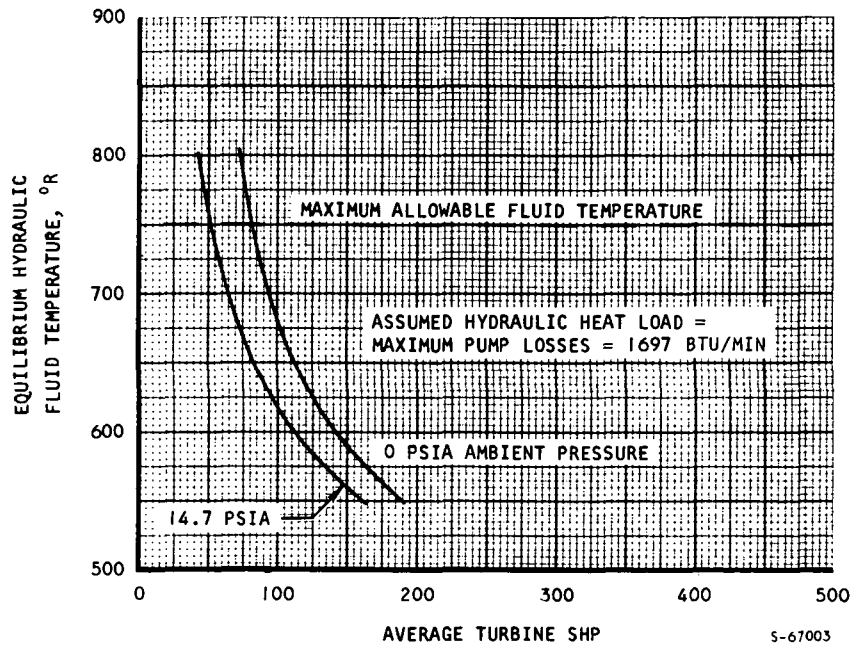

Figure 6-9. O/F Correction for Hydraulic Fluid Temperature Variation and 75°R Inlet Hydrogen Temperature

balance will be obtained. The steady-state performance data show that insufficient cooling will be available at acceptable equilibrium temperature levels for the low output power level conditions. The variation of hydraulic fluid temperature with time is important in determining the adequacy of the hydraulic thermal control provisions of the APU.

### Analytical Model

Figure 6-10 shows the analytical model used for transient-state evaluation of system hydraulic cooling performance. Each hydraulic system is supplied by two pumps from separate APU's. Hydraulic heat load is assumed to be constant and equal to the pump losses at full output. In actuality, the hydraulic system heat load will be somewhat higher because of the leakage and inefficiencies of the hydraulic actuators. The present analysis neglects hydraulic loads other than that of the pump. As shown in Figure 6-10, transient-state performance is given by a heat balance for the hydraulic system, considering the lumped thermal inertia of the hydraulic system as a heat sink.

### Orbiter Vehicle System Analysis

From the NASA-supplied power profiles, the worst hydraulic fluid heating condition is obtained in the orbiter vehicle during a 4000-sec period in which the APU supplies a 10-hp hydraulic output. Assuming the use of a small alternator for the orbiter APU, the net power output from the gearbox is 40 + 3 + 10 or 53 hp. During this time, the ambient pressure is 0 psia.

Figure 6-11 shows the heat rejected to the cycle hydrogen flow as a function of hydraulic fluid temperature and system hydrogen inlet temperature. Assuming the thermal capacity of the hydraulic system (per APU) to be equivalent to 200 lb of hydraulic fluid and 1500 lb of steel, the hydraulic fluid temperature/time relationships shown in figure 6-12 are obtained for the problem condition described previously. For the system hydrogen supply temperature of 75°R, the hydraulic fluid temperature rise will not be excessive with initial hydraulic fluid temperatures up to approximately 600°R. Where the hydrogen is supplied to the APU at 300°R, the initial hydraulic fluid temperature must be less than 500°R to avoid an excessive temperature. Since a minimum hydraulic temperature of 530°R has been specified by NASA, it appears that adequate cooling will not be available from the APU for the problem condition at a hydrogen supply temperature of 300°R. Supplemental cooling provisions will be required to meet this condition for the orbiter vehicle hydraulic system. This can be accomplished by separate cooling provisions for the hydraulic system or by modification of the APU cycle to dump hydrogen to provide sufficient cooling for this condition.

ASSUMED HYDRAULIC SYSTEM PARAMETERS

ORBITER BOOSTER	
METAL WEIGHT, LB	1500 6000
FLUID WEIGHT, LB	200 600
$(WC_p)$ SYSTEM, BTU/°F	350 900

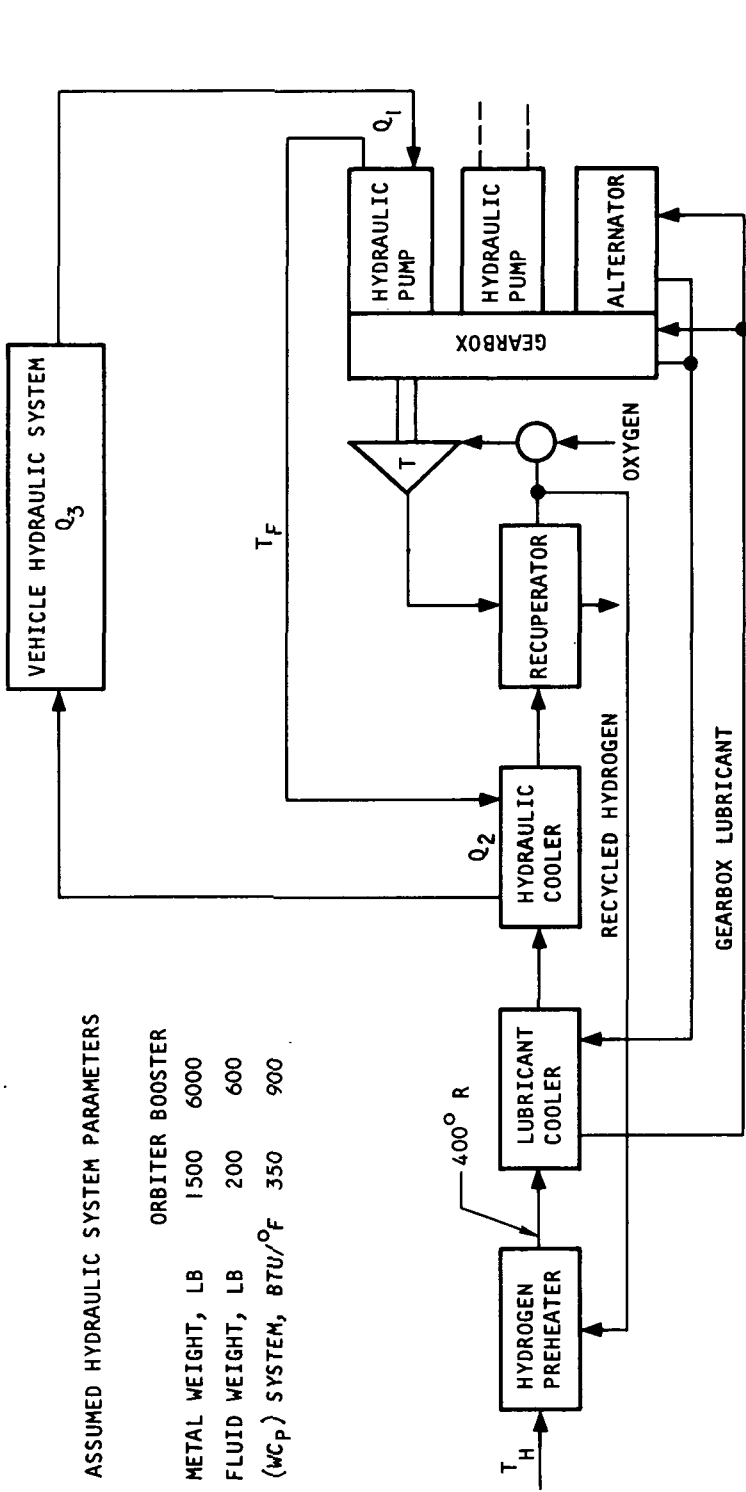

ASSUMPTIONS

- $Q_1 = 1697 \text{ BTU/MIN}$
- $Q_2 = f(T_H, T_F, P_{AMB})$
- $Q_3 = (WC_p) \text{ SYSTEM } (dT_F/d\theta)$

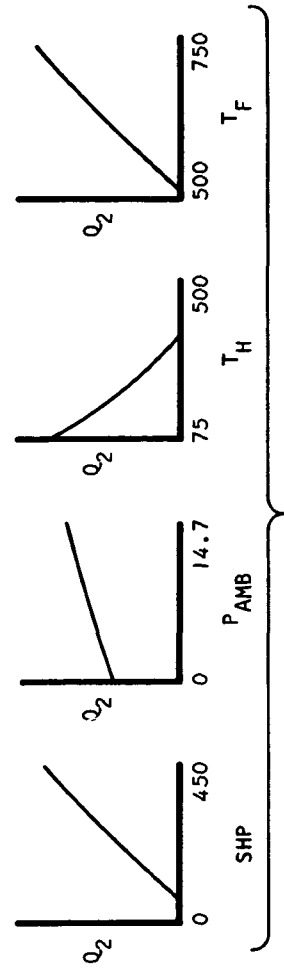

DETERMINED BY APU SYSTEM STEADY-STATE PERFORMANCE PROGRAM

5-66988

Figure 6-10. Hydraulic Transient-State Analysis Mathematical Model

① HYDRAULIC OIL HEAT REJECTION AS A FUNCTION OF HYDRAULIC OIL HEAT EXCHANGER INLET TEMPERATURE AND HYDROGEN SYSTEM INLET TEMPERATURE

② NET  $Q_{INPUT}$  TO HYDRAULIC FLUID OIL MASS AS A FUNCTION OF HEAT EXCHANGER INLET TEMPERATURE AND HYDROGEN SYSTEM INLET TEMPERATURE

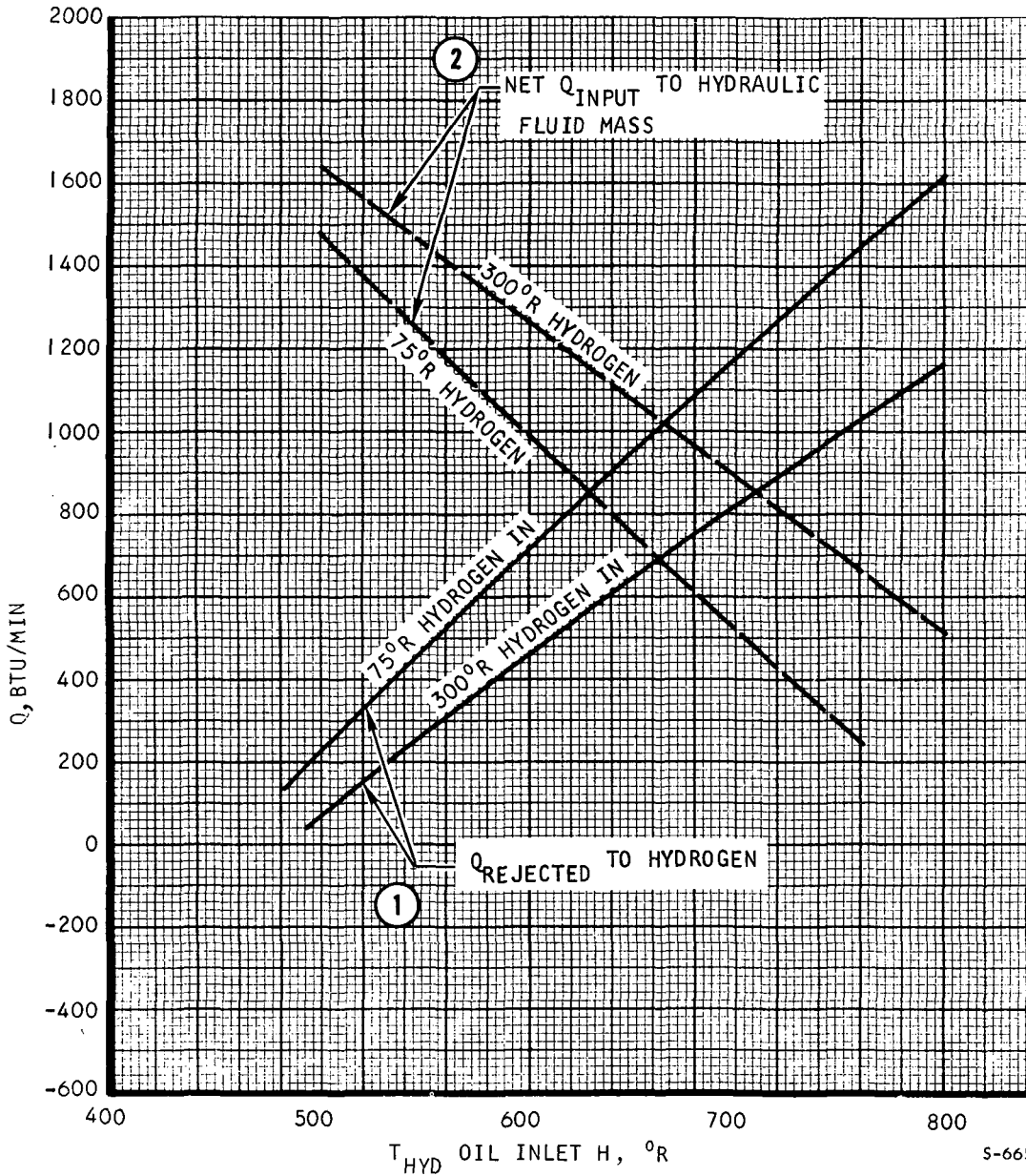

S-66528

Figure 6-11. Heat Rejected to Cycle Hydrogen Flow and Net Heat Input to Hydraulic Oil

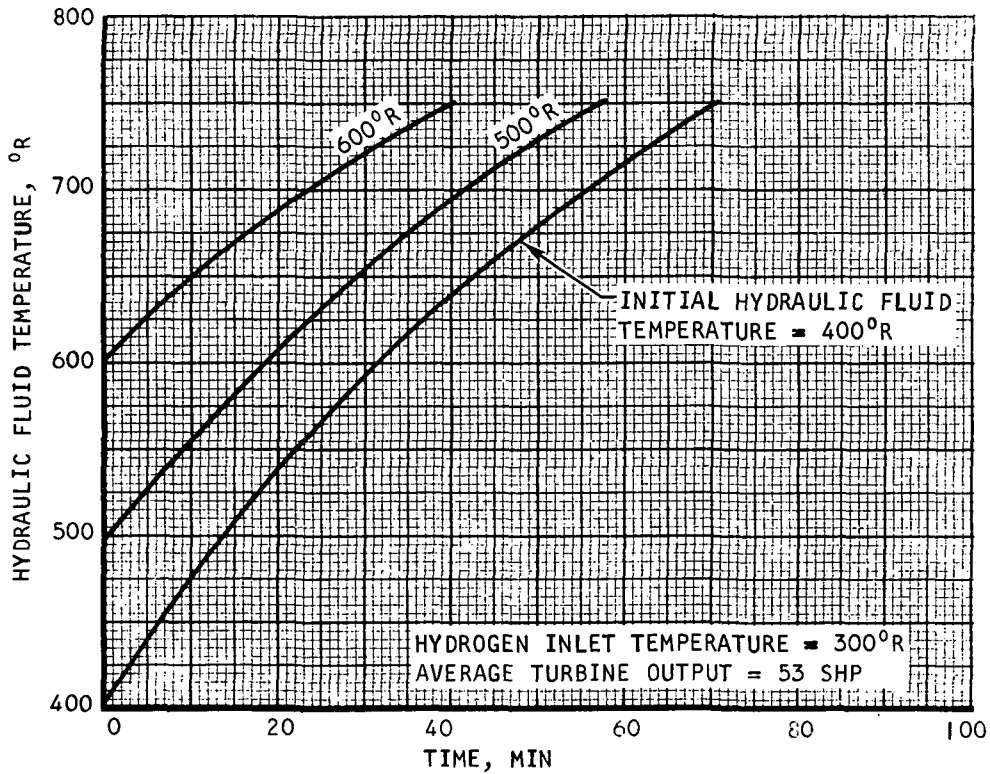
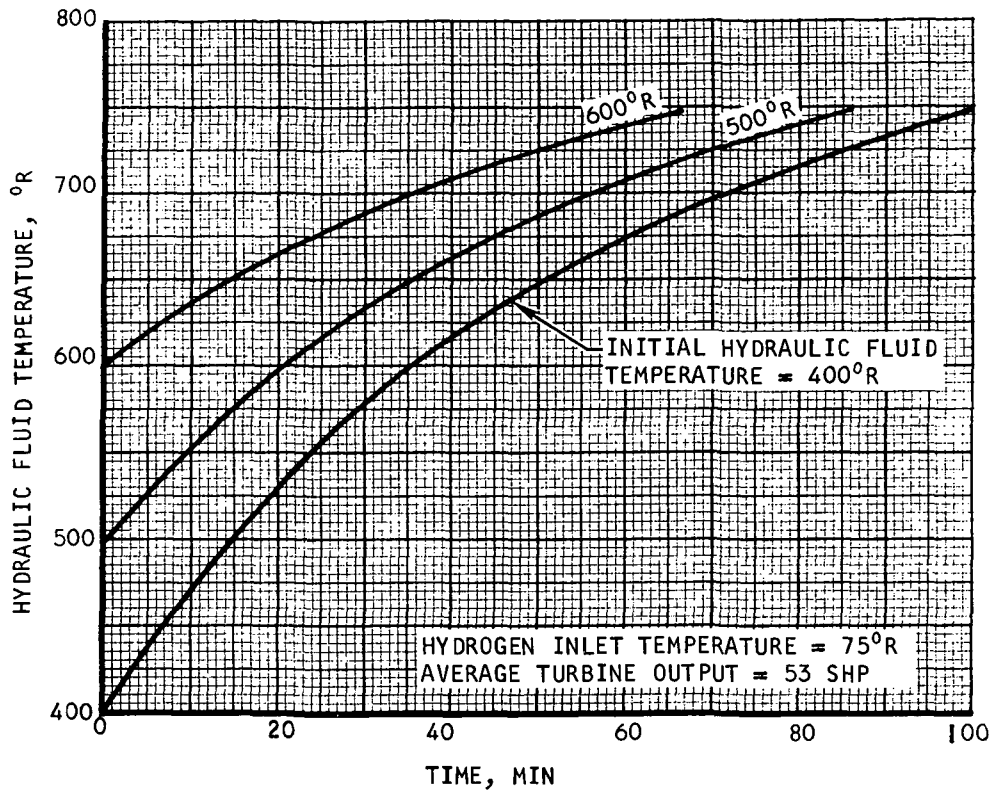

Figure 6-12. Hydraulic Fluid Temperature Variation with Time for Orbiter Vehicle Minimum Load Condition

S-66943

## CONCLUSIONS

The preceding analyses indicate that extended periods of low-power operation may result in excessive hydraulic fluid temperatures since the equilibrium temperature (temperature at which the heat generated by the pump can be dissipated to the hydrogen) is over 750°R. However, the selected cycle concept maximizes the cooling available to the hydraulic load so that any additional cooling by the APU itself is not possible. If the final vehicle power profiles require long-duration, low-power conditions, it may be necessary to provide supplementary cooling in the hydraulic system or to vent hydrogen from the APU overboard for the cooling.

## SECTION 7

### FLUID DYNAMIC STUDIES

#### INTRODUCTION

The fluid dynamic studies reported in this section had the following general objectives:

Develop and compare turbine speed control concepts.

Analyze operational characteristics of control concepts.

Select specific control types and design parameters.

Verify APU system characteristics and operational stability when subjected to various types of transient disturbances.

The work described here used an analog model. Results of the digital transient-state analysis are contained in Volume III.

#### DYNAMIC FLOW MODEL

The analytical model, depicted in Figure 7-1, contained the fluid components that interface directly with control of fluid pressure and flow. Table 7-1 lists the principal study variables. Table 7-2 lists the component parameters and leading characteristics. Figures 7-2 and 7-3 show the programmed sequences for turbine shaft power and propellant inlet pressure that were used in the fluid dynamic studies.

Two basic types of control were investigated, the integrating valve control shown in Figure 7-4, and the droop valve control shown in Figure 7-5. The integrating valve control is operated by opening or closing the valve at a rate that is determined by the difference between the sensed turbine speed and the desired speed. The droop control adjusts the valve position in proportion to the difference between the sensed and the desired turbine speed.

#### ANALOG RESULTS

Results of the analog runs performed on the fluid dynamic model are discussed in the following paragraphs. All runs using integrating control are discussed first, followed by the runs using droop control of turbine speed.

##### Integrating Control

A total of 14 runs was made using the basic integrating control concept for turbine speed control. Table 7-3 summarizes the variables describing the runs. Figures 7-6a, b, and c illustrate the impact upon system flow stability caused by the rate of feedback used in the control loop. For these three runs, the power at the turbine shaft is held constant at 75 hp, while the inlet

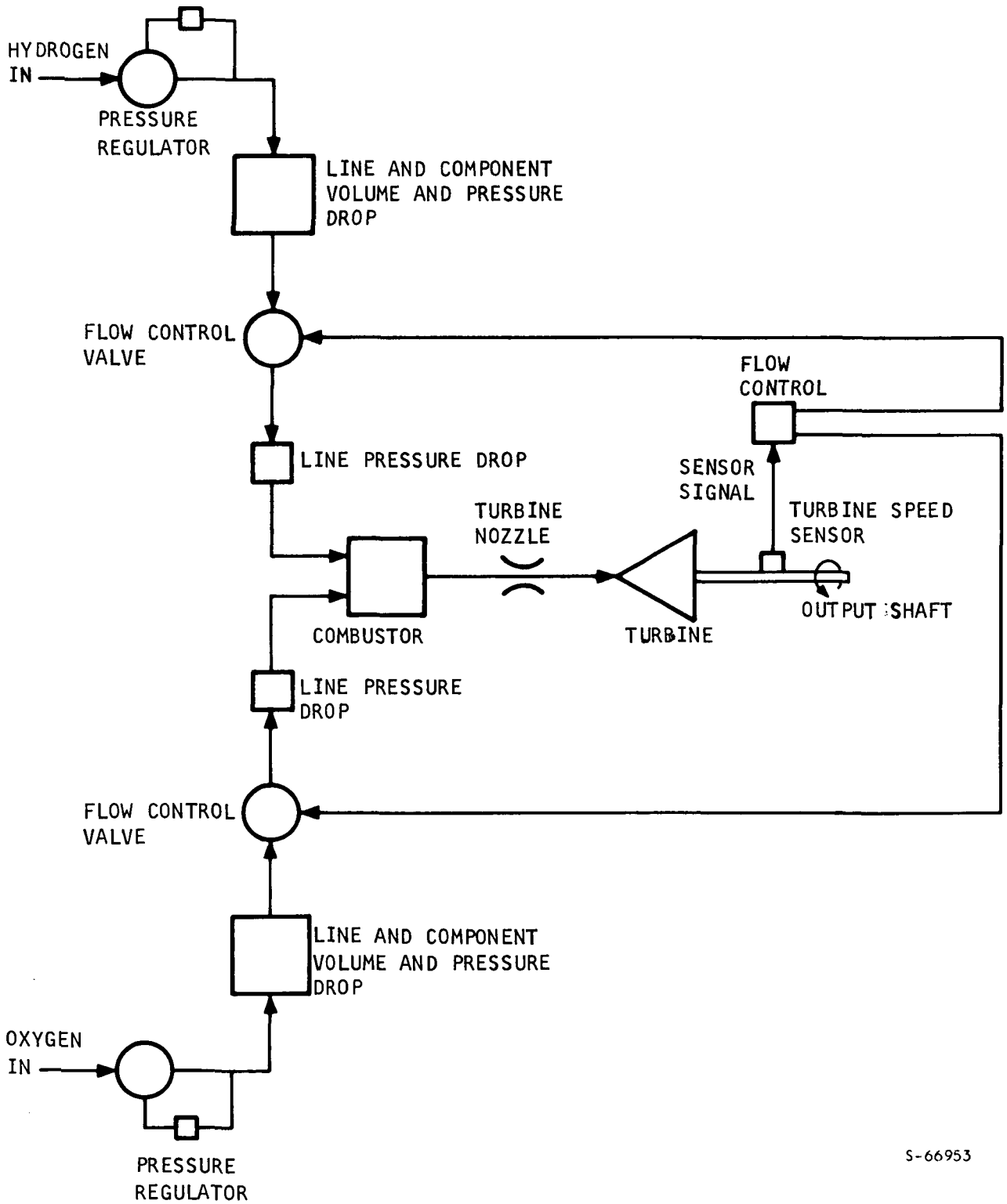

S-66953

Figure 7-1. Dynamic Flow Model, Analog Evaluation

TABLE 7-1

PRINCIPAL STUDY VARIABLES

Operating Requirements		
Propellant supply pressure		500 to 1000 psi
Turbine load horsepower		75 to 380 hp
Turbine startup under nominal load		200 hp
Component Characteristics		
Flow control	Integrating	<ul style="list-style-type: none"> <li>● With/without deadband</li> <li>● Variable feedback rate</li> </ul>
	Droop	<ul style="list-style-type: none"> <li>● With compensation</li> <li>● Time constant variable</li> </ul>
Pressure control	Pneumatic feedback	<ul style="list-style-type: none"> <li>● 100 msec</li> </ul>

TABLE 7-2

LEADING CHARACTERISTICS OF DYNAMIC ANALOG MODEL

Component	Characteristic
Pressure regulator	±25 psia tolerance, valve full open at 475 psia downstream pressure; 100-msec response
Ducts and components	
Hydrogen side	Volume = 3521 cu in. Pressure drop at full flow = 47 psi Maximum flow = 6.93 L/min
Oxygen side	Volume = 5 cu in. Pressure drop at full flow = 0.1 psi Maximum flow = 4.41 lb/min
Combustor	Volume = 26 cu in.
Flow valves	Controlled by either integrating or droop control technique  Valve sizing based on full open at 66,500 rpm, and full closed at 73,500 rpm  Droop valve control includes a time constant for actuation ranging from 50 to 200 msec
Turbine	Turbine shaft output power variation between 75 and 380 hp  Speed change of turbine related to load horsepower and turbine/gear box inertia as follows: $\alpha = \Delta HP \times 12.85$ Turbine speed sensor lag = 50 msec; turbine nozzle area = 0.1127 sq in.
Fluid properties	
Hydrogen side	Average temperature of gas in ducting and components = 491°R
Oxygen side	500°R
Combustion gas	$\tau = 1.36$ $R = 451 \text{ ft lb/lb-}^\circ\text{R}$ $M = 3.48$

CONSTANT LOADS OF 75 AND  
380 HP WHILE OTHER SYSTEM  
INPUT VARIABLES WERE  
EXERCISED

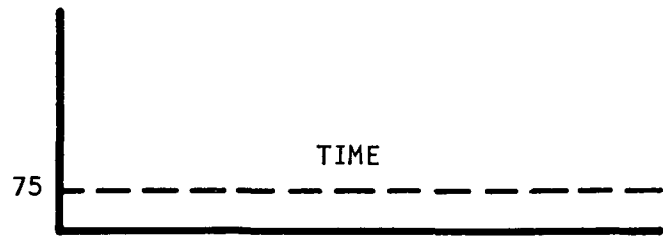

PROGRAMMED LOAD VARIATION  
TO GIVE REPRESENTATIVE  
LOADS FOR ORBITER  
APPLICATION

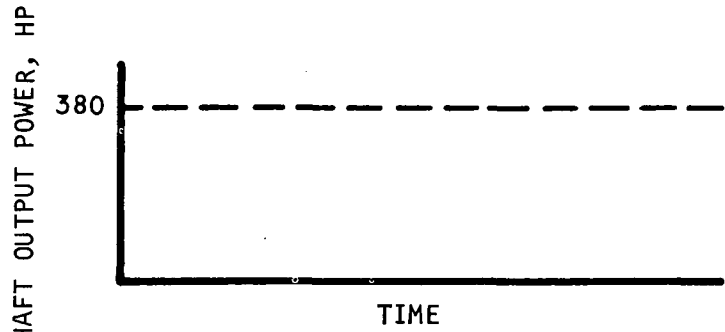

PROGRAMMED LOAD VARIATION  
TO DETERMINE SENSITIVITY  
OF CONTROL AND SYSTEM  
RESPONSE TO SPIKE LOADS  
LIKELY TO BE ENCOUNTERED  
IN APPLICATION

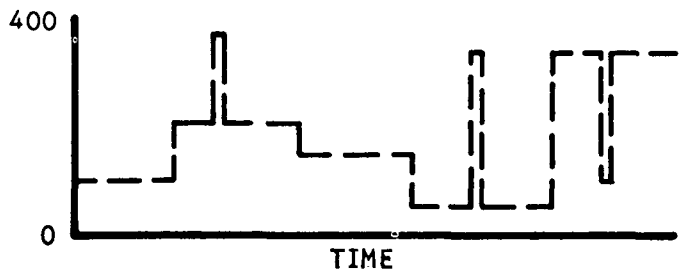
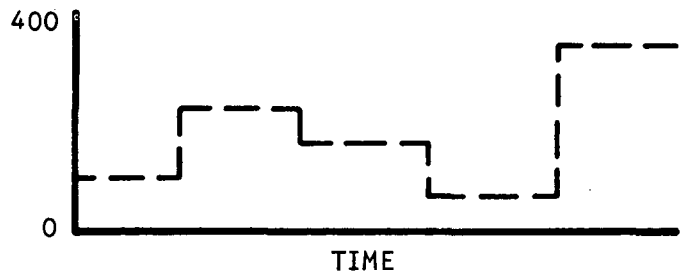

S-66954

Figure 7-2. Turbine Output Shaft Load Programmed Sequence

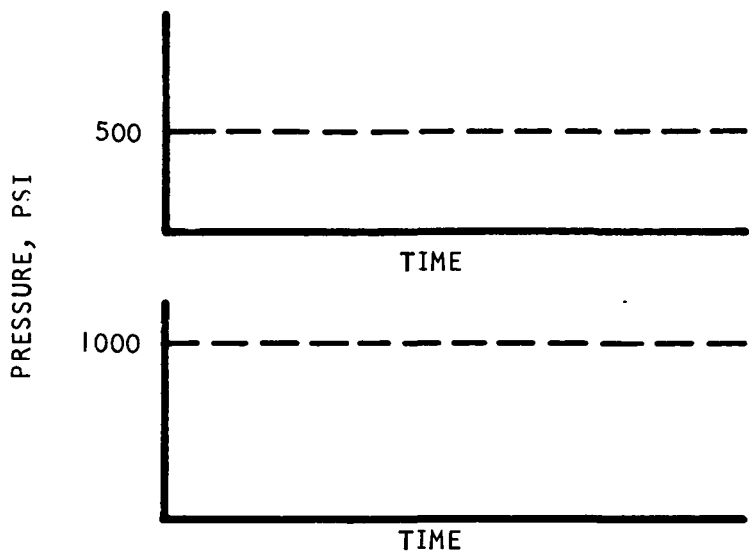

CONSTANT PRESSURES OF 500 AND 1000 PSI WHILE LOAD PROFILES WERE EXERCISED

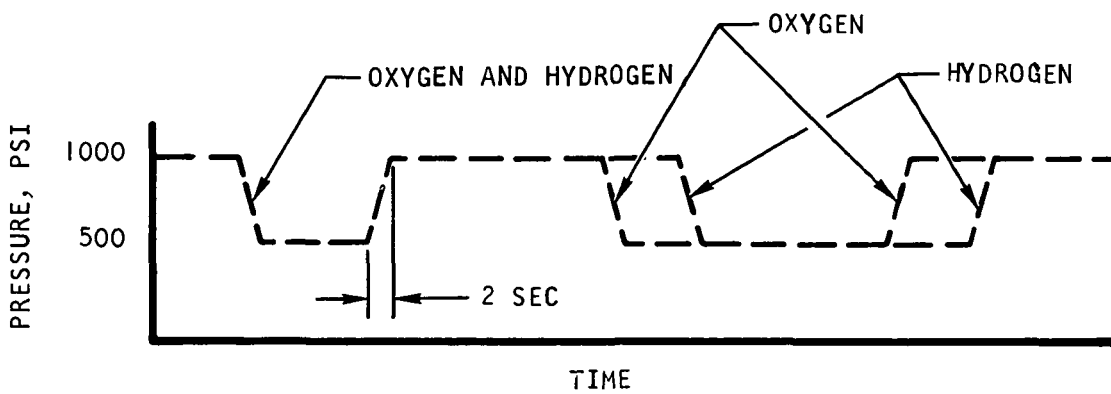

PROGRAMMED PRESSURE VARIATIONS TO PRESSURE REGULATIONS

S-66955

Figure 7-3. Propellant Inlet Pressure Programmed Sequence

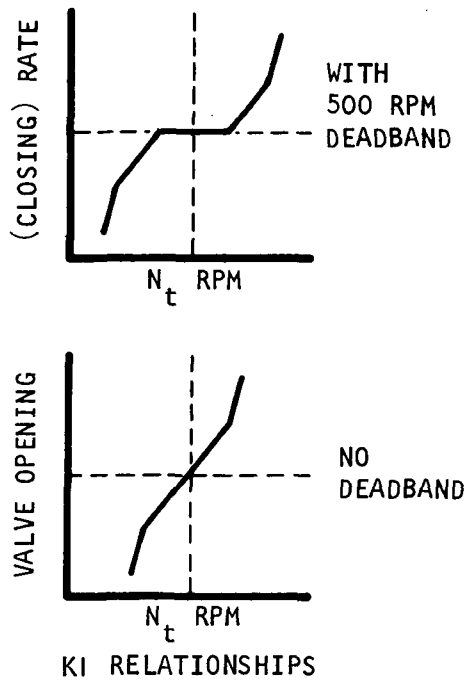
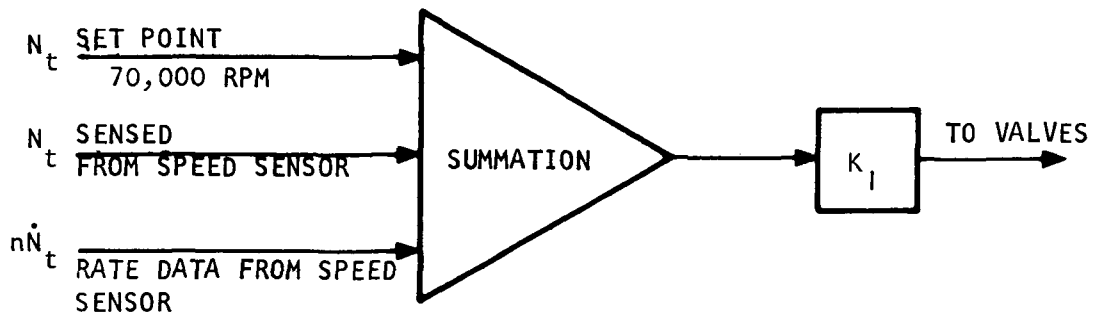

KI RELATIONSHIPS

S-66956

RATE FEEDBACK EVALUATED TO VERIFY STABILITY OF CONTROL AND MINIMIZE VALVE CYCLING. VALUES OF  $n$  ARE 0.0, 0.06, 0.1, AND 0.3

Figure 7-4. Integrating Valve Control

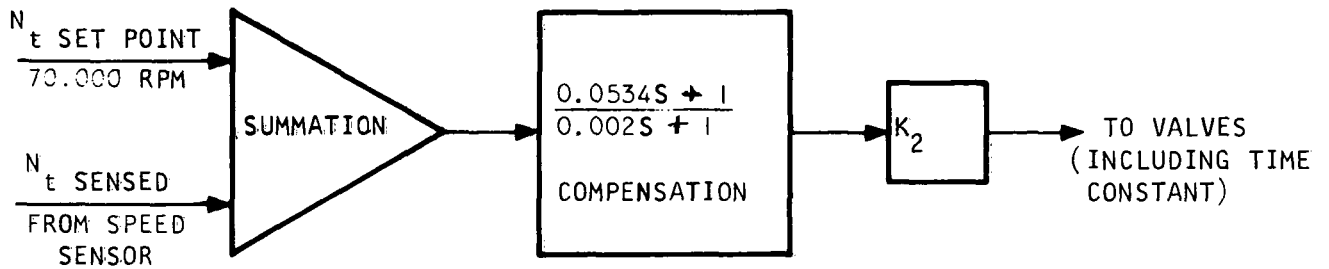

$K_2$  CAUSES THE VALVE TO STROKE FULL OPEN (OR CLOSED), CORRESPONDING TO A 2000-RPM DIFFERENTIAL FROM SET POINT. VALVE TIME CONSTANT VARIED TO DEVELOP VALVE REQUIREMENTS IN TERMS OF SYSTEM OPERATION.

RESPONSE TIME = 50, 100, 200 MILLISECONDS

- COMPENSATION LAG TERM (0.0534) DETERMINED FROM INSTABILITY FREQUENCY OF UNCOMPENSATED DROOP VALVE
- COMPENSATION LEAD TERM (0.002) DETERMINED BY NEED FOR LARGEST PRACTICAL FREQUENCY SEPARATION

S-66957

Figure 7-5. Droop Valve Control

TABLE 7-3

## INTEGRATING VALVE CONTROL RUN CONDITIONS AND RESULTS

Run No.	Reference Figure No.	Turbine Power, hp		Propellant Pressure, psia		Speed Control Feedback Rate	Results
		Constant	Load Profile	Programmed Variation	Constant		
1	7-6a	75		500 to 1000		0	Flow valves and flow rates exhibit instability; operate like pulse-modulated control
4	7-6b	75		500 to 1000		0.06	Stable operation
7	7-6c	75		500 to 1000		0.1	Stable operation
2	7-7a	380		500 to 1000		0.0	Flow valves modulate in unstable manner
5	7-7b	380		500 to 1000		0.06	Underdamped oscillation of flow control valve
8	7-7c	380		500 to 1000		0.1	Underdamped oscillation of flow control valves
3	7-8a		Programmed		1000	0.0	Flow valves and flow rates exhibit instability; operate like pulse-modulated control
6	7-8b		Programmed		1000	0.06	Underdamped oscillation of flow control valves
9	7-8c		Programmed		1000	0.1	Critical damping of flow valves except at highest power output
18	7-9a		Programmed		1000	0.3	Stable operation, no valve overshoot
19	7-9b		Programmed with spikes		1000	0.3	Stable operation
20	7-9c		Startup		1000	0.3	Stable operation, 1-3/4 sec to reach rated speed
21	7-10a		Programmed with spikes		1000	0.3	Stable operation, some valve position overshoot
22	7-10b		Startup		1000	0.3 No deadband	Stable operation, 1-3/4 sec to reach rated speed
						No deadband	

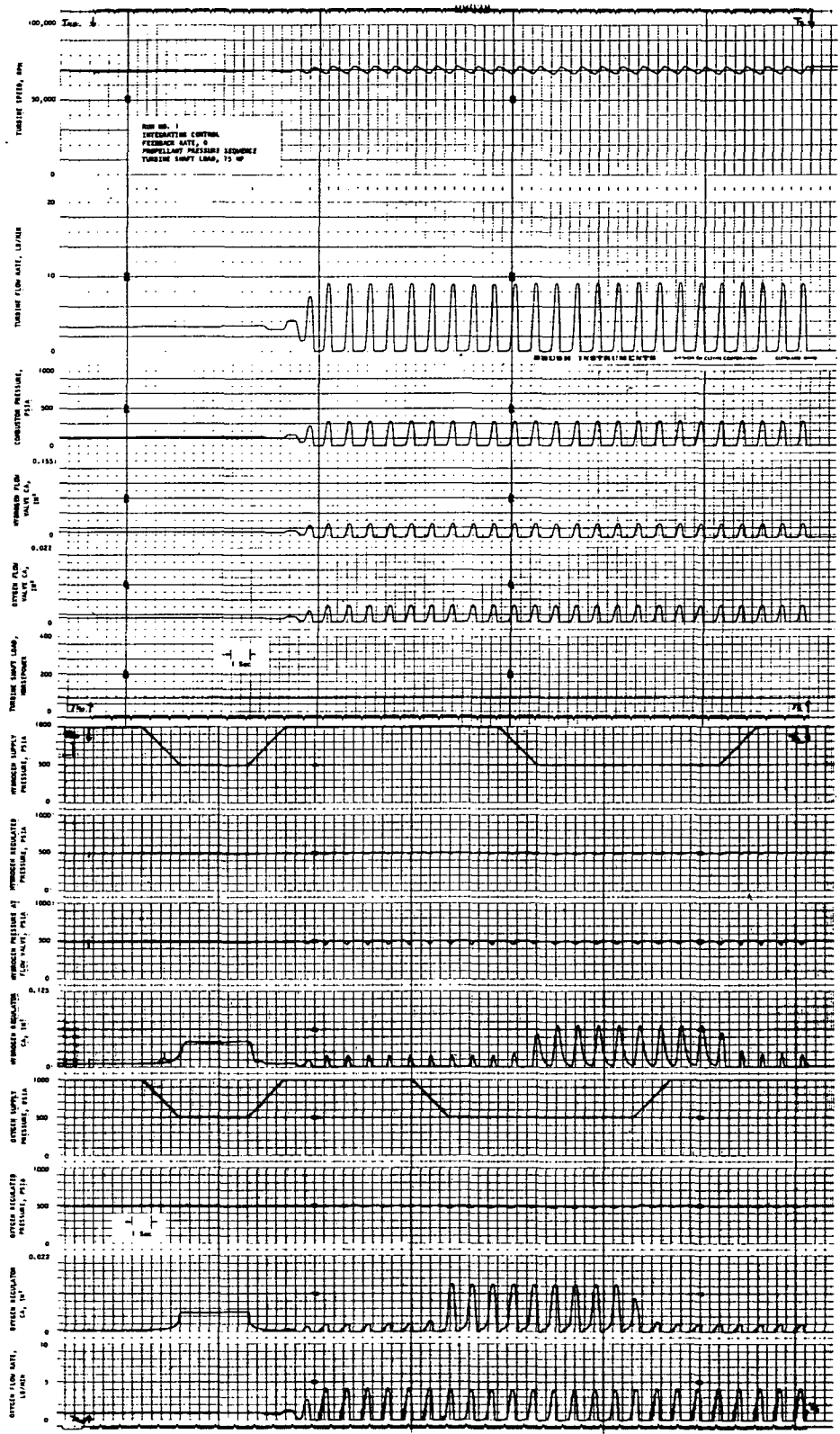

Q

Figure 7-6



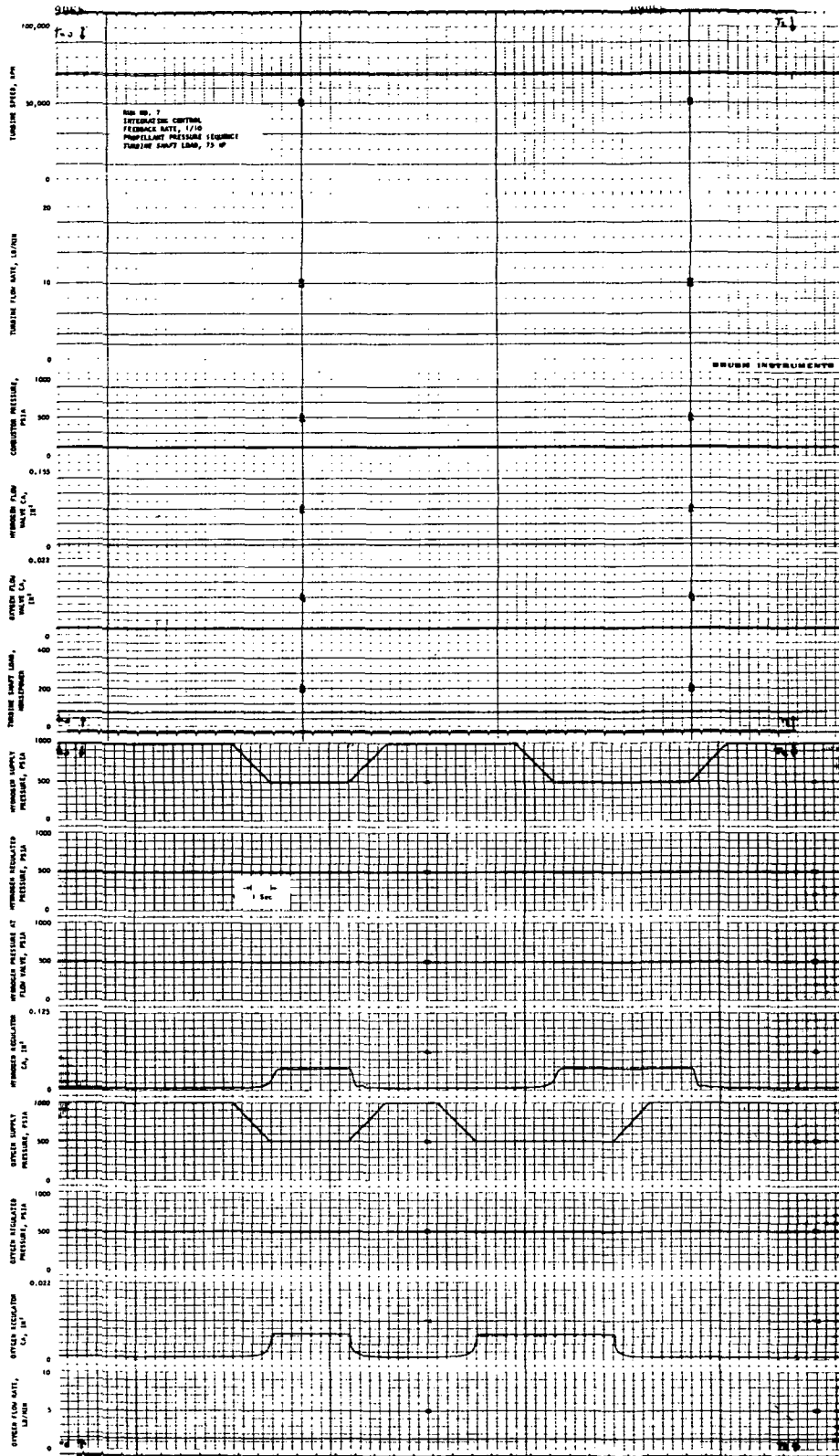

C

Figure 7-6

pressure to the APU pressure regulators is programmed to exercise the pressure control provisions of the loop. Figure 7-6a, no feedback, shows that the system oscillates in an unstable manner with only the smallest excitation force applied to the system. Figures 7-6b and c show that the feedback rates of 0.06 and 0.1 are sufficient to maintain a stable turbine speed and to eliminate the cyclic operation of valves, and the pressure and flow variations evident in Figure 7-6a.

Figures 7-7a, b, and c illustrate system behavior when the turbine shaft power is increased to 380 hp, and the input pressure to the system pressure regulators is programmed to vary between 500 and 1000 psi. Figure 7-7a shows that the valve oscillations are unstable, as evidenced by the increasing amplitude of the hydrogen and oxygen flow valves CA near the end of the trace. This indicates that without feedback, the system flow will likely become unstable when the slightest external perturbation is experienced. Figures 7-7b and c show that the oscillations are reducing in amplitude after a perturbation with higher feedback rates, but that the total time to become stable will exceed 20 sec. The importance of the oscillations of the flow control valves is in the increased valve cycle life requirements caused by the unstable flow control. The valves will be unnecessarily modulating flow, and will be experiencing cycle fatigue orders of magnitude higher than required to satisfy the power variations of a typical mission.

Figures 7-8a, b, c show the results of system performance caused by a programmed variation of the turbine power output and with constant reactant supply pressure of 1000 psi. Figure 7-8a shows a similar pattern of oscillation of the flow valves, as did Figures 7-6a and 7-7a. The flow valves are seen to close completely, then open, and then close. This behavior is similar to the pulse method of speed control. The turbine speed is seen to be maintained within the required 3500-rpm speed tolerance, but the variation in speed is cyclic with a period of approximately 1 sec. At the highest power level, the speed is seen to be relatively constant, and the flow valves do not close completely with each cycle. This is expected since the flow valves must stay open a greater percentage of the time to provide the total flow for power of the turbine.

Figure 7-8b shows a marked improvement in system stability. Although the system oscillates, the amplitude of oscillations is less than the preceding figure, and the oscillations are reducing with time. The significance of this is the excessive valve cycle fatigue imposed on the system. The system can physically tolerate the flow variations and the minor resulting pressure variations, but the valve cycle life will be adversely effected.

Figure 7-8c shows the system to be dramatically more stable with the feedback increased to the value of 0.1. The traces indicate that the flow valves oscillate slightly after a programmed load change, and reveal that the worst oscillation is experienced with the highest flow corresponding to the high load requirement.

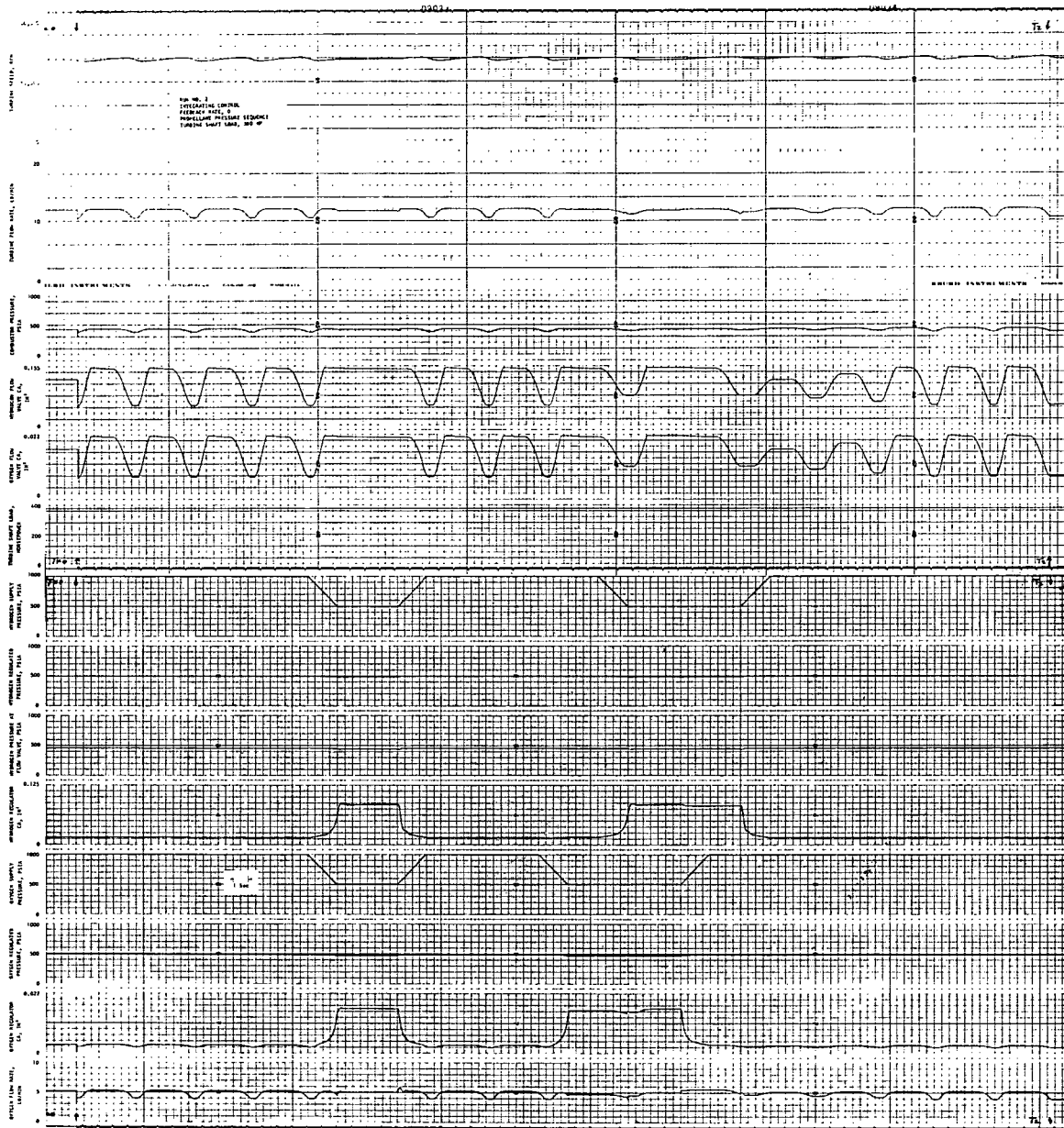

a  
Figure 7-7

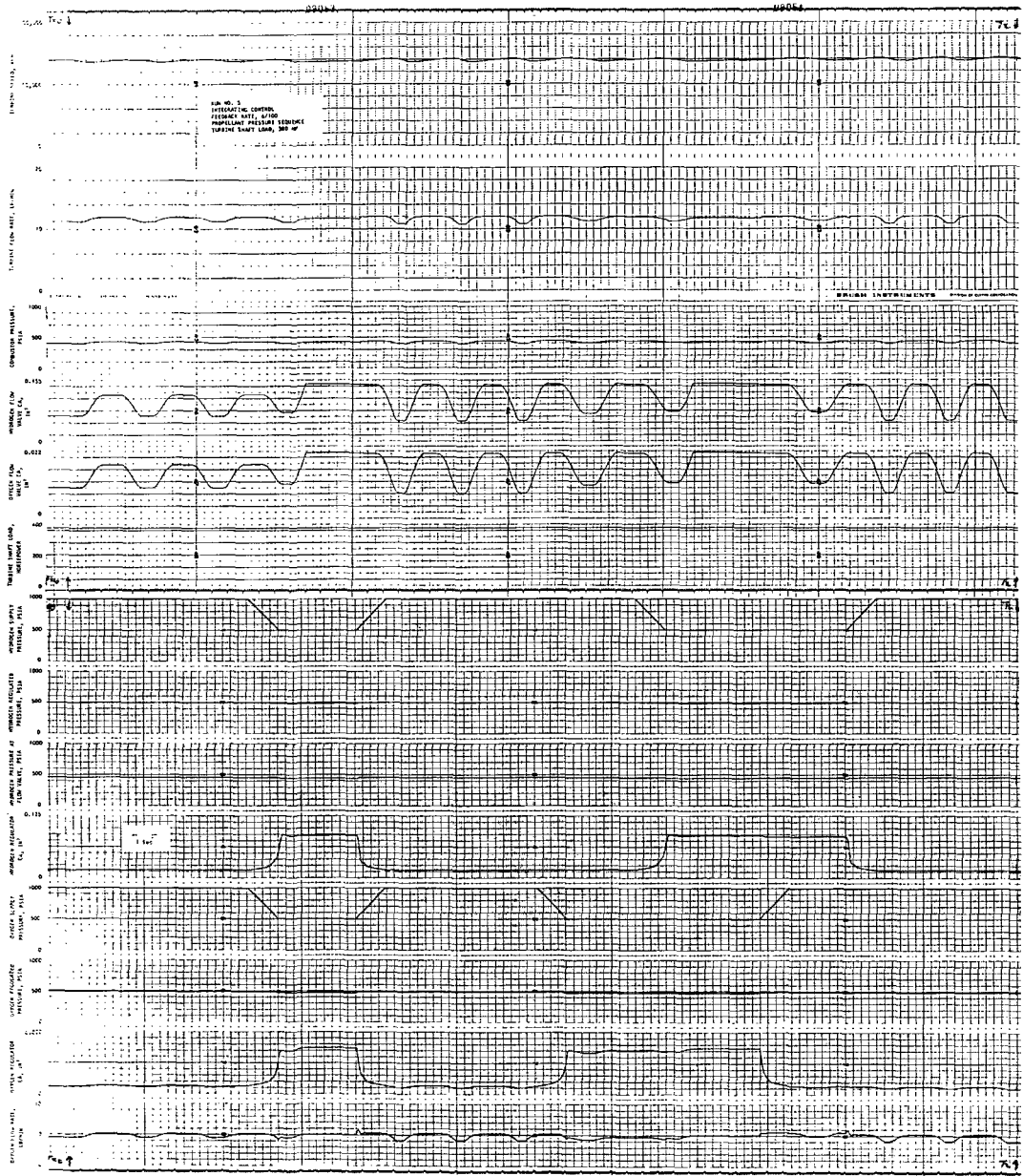

b  
Figure 7-7



**Page Intentionally Left Blank**





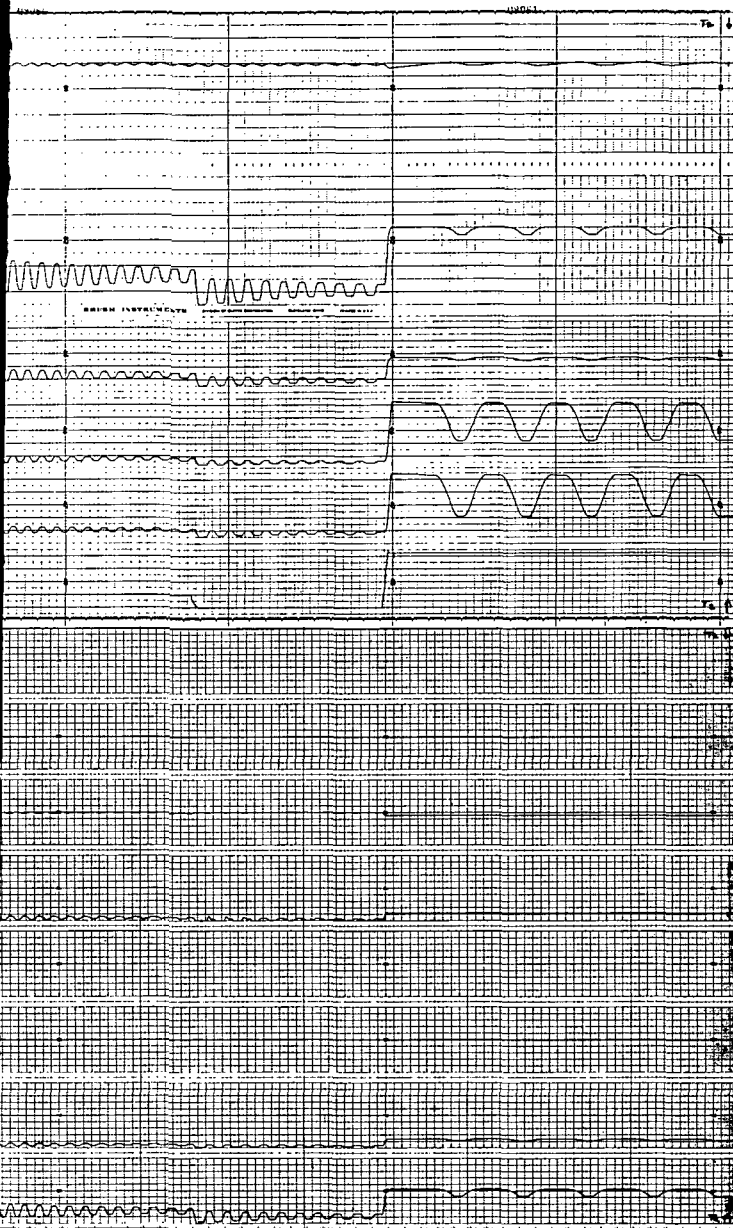

8

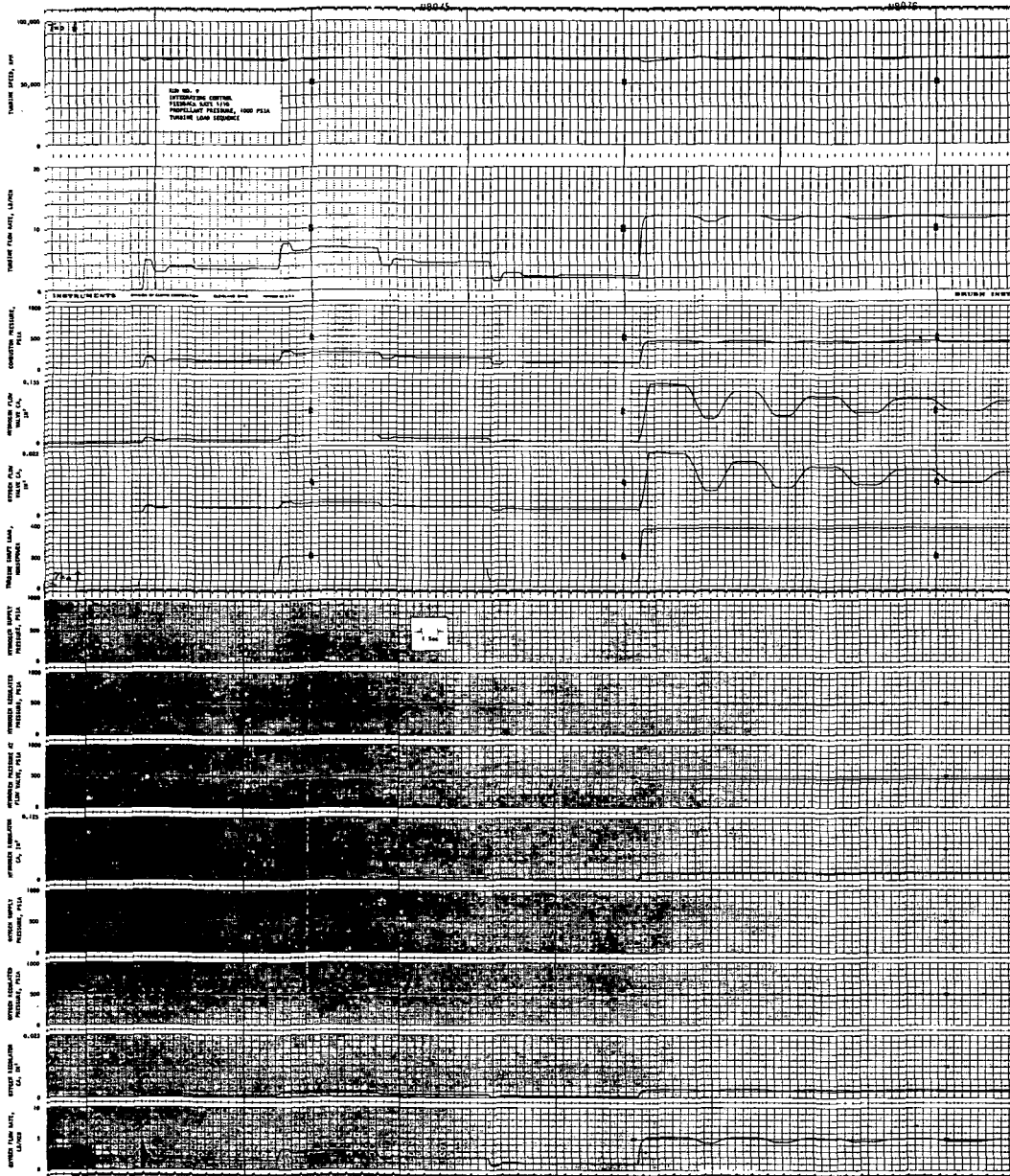

c  
Figure 7-8

Figure 7-9a shows the system response to load variations based on a feedback of 0.3. Here it is seen that the valves are stable, the turbine speed is maintained without oscillation, and the system flows are constant at load. Since this value of feedback appears to provide the required system stability, the load profile was modified to include spike loads lasting only a fraction of a second, to represent practical application to the orbiter or booster hydraulic demands. Figure 7-9b shows the results of this simulation. The spikes result in the system responding in a uniform and stable manner; turbine speed, system flow, and valve positions are all stable. Some minor overshoot is seen in the valve position, which results in an overshoot in the flow to the combustor. The turbine speed responds to this overshoot but always remains within 2000 rpm of the design speed of 70,000 rpm.

Figure 7-9c shows the system response to a simulated startup. Here the turbine was started under a constant load of 200 hp. The control is seen to cause full flow to the turbine until design speed is reached, whereupon the flow is modulated to the required partial load condition and maintained at the constant value. The startup transient occurs in a period of approximately 1-3/4 sec.

Figures 7-10a and b show the system performance using a variation of the integrating control discussed earlier. In the previous runs, a deadband was included in the control of 500 rpm on either side of the design set point of 70,000 rpm. The runs of Figure 7-10 are based on elimination of the deadband, as shown in figure 7-4. Comparing the runs of 7-9b and c with 7-10a and b shows nearly identical system characteristics. The magnitude, or indeed the presence, of the deadband in the control loop therefore seems to be based on other considerations than those developed from these analog runs. For example, the ease of design of the control unit may dictate that a small deadband (10 rpm) be used simply to eliminate ambiguity at the set point.

The startup transient shown in Figure 7-10b indicates results similar to the previous startup transient and a duration of approximately 1-3/4 sec.

### Droop Control

Droop control was evaluated using a total of 8 runs. The droop control was described in figure 7-5. Table 7-4 describes the variables studied and summarizes results of the runs.

Figure 7-11a and b show that the system performs well, without oscillations, at the constant power levels of 75 and 380 hp when perturbations in inlet reactant pressures are experienced. For both runs shown, the time constant for the flow control valves was assumed to be 100 msec.

Figure 7-12 shows a progression of runs based on varying the flow valve time constant from 200 to 50 msec. For each run the reactant supply pressure is held constant at 1000 psi and the load at the turbine shaft is varied according to a program. Figure 7-12a shows that turbine speed is not held within the 3500-rpm speed band when the valve response time is 200 msec. Also, the flow oscillations caused by the valve position oscillations have a

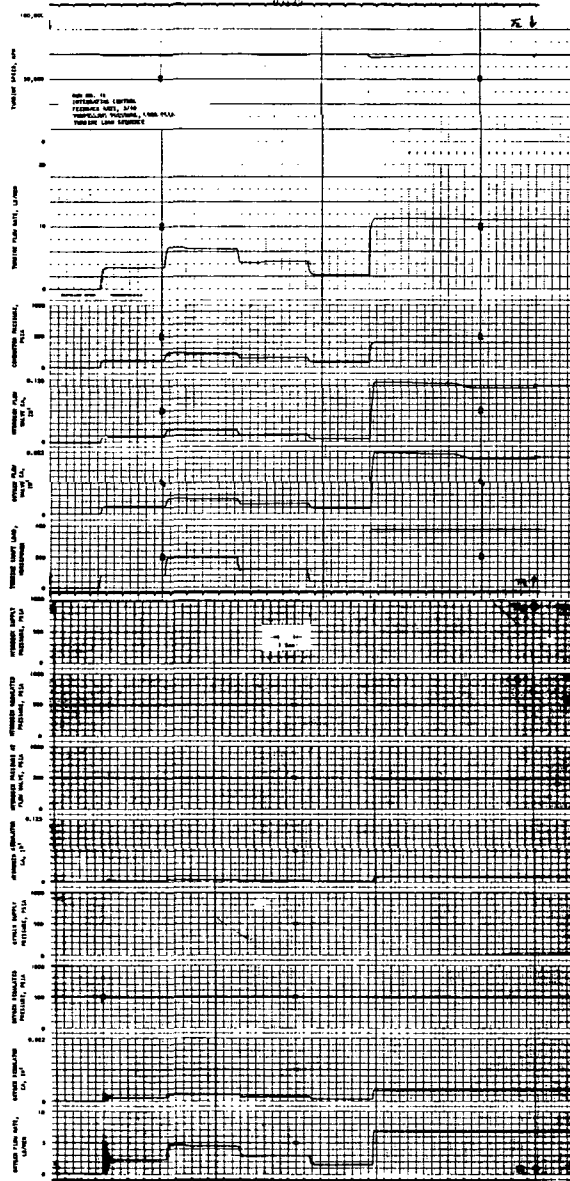

a

Figure 7-9

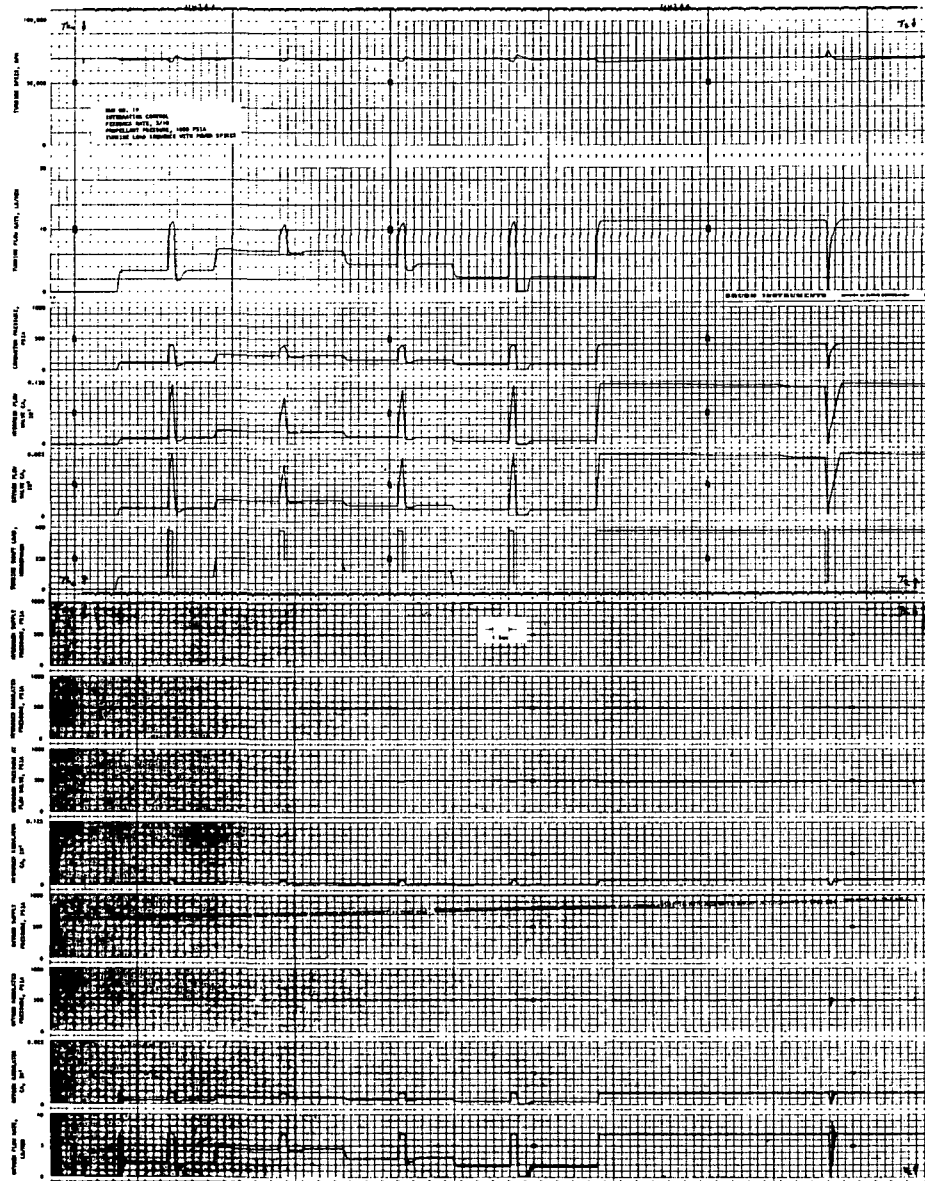

**b**

Figure 7-9



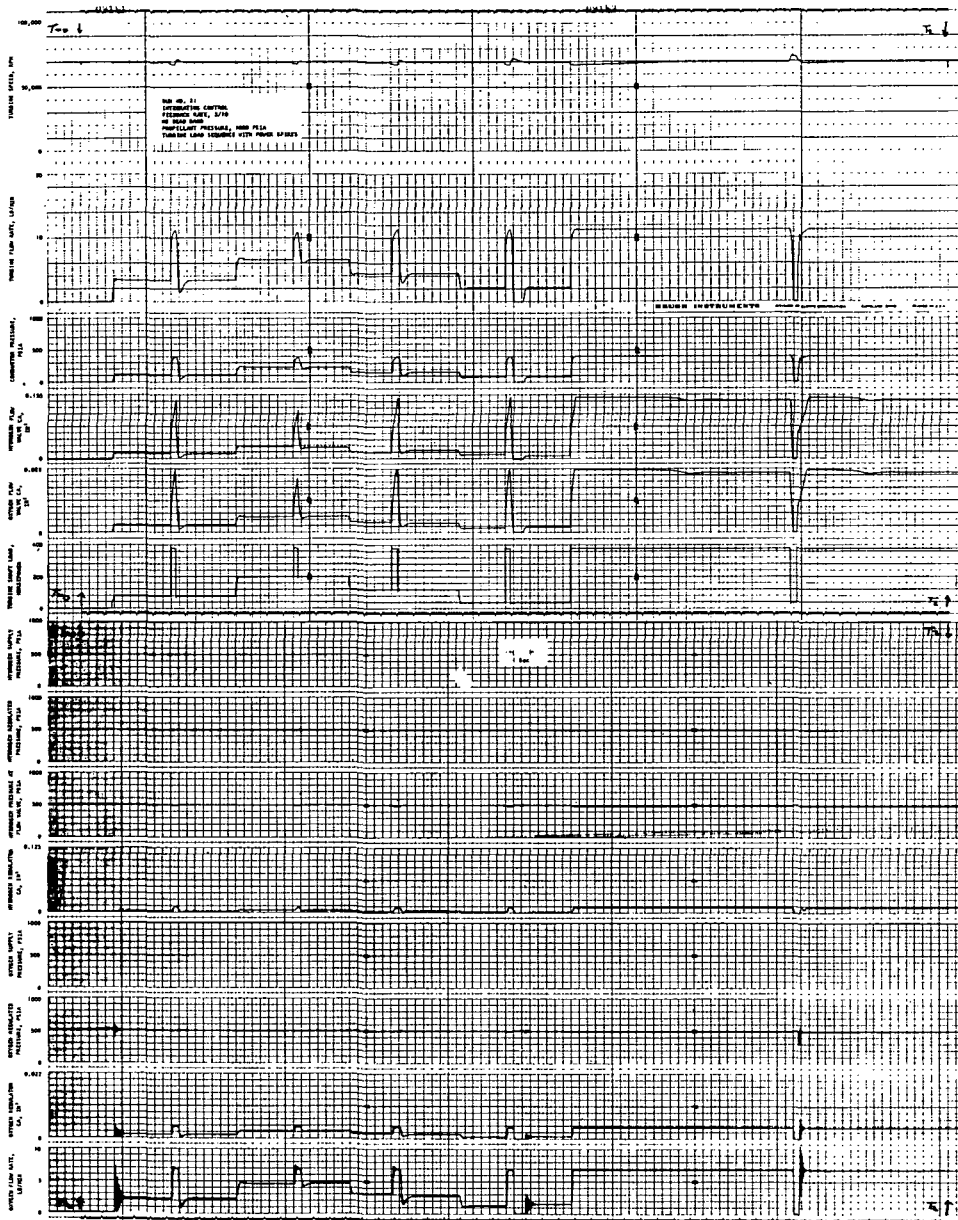

a  
 Figure 7-10

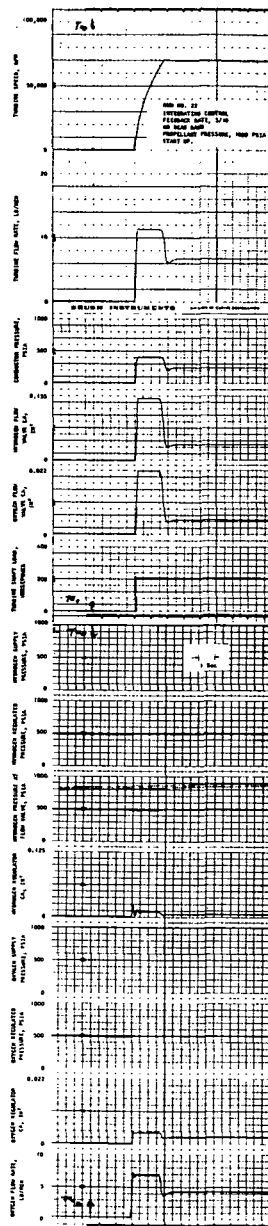

b

Figure 7-10

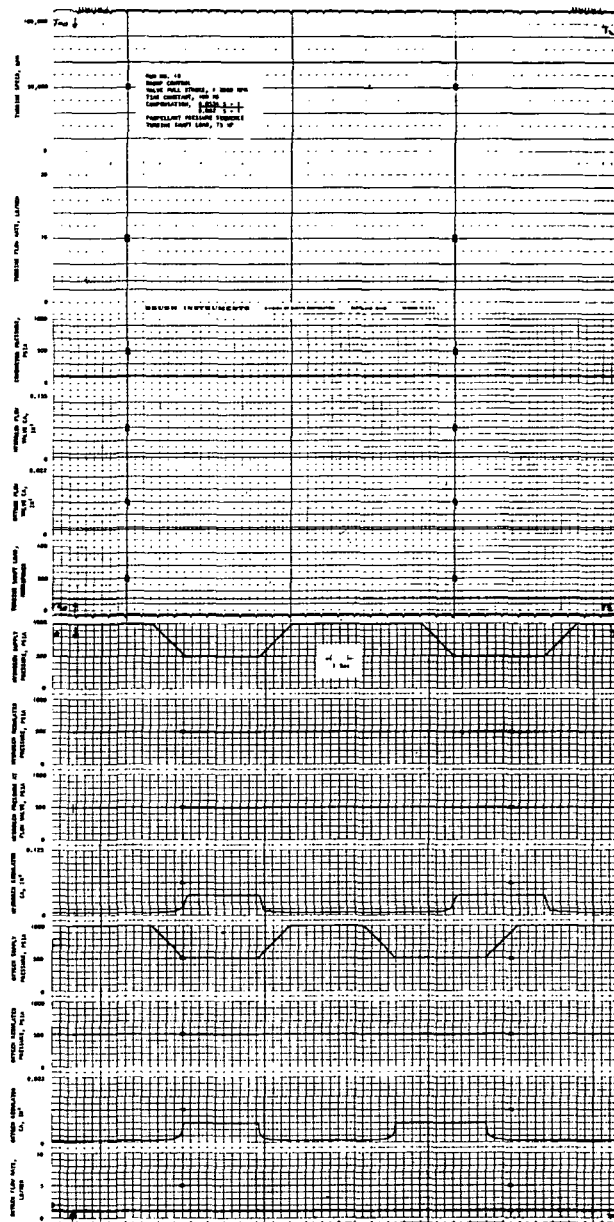

Figure 7-11



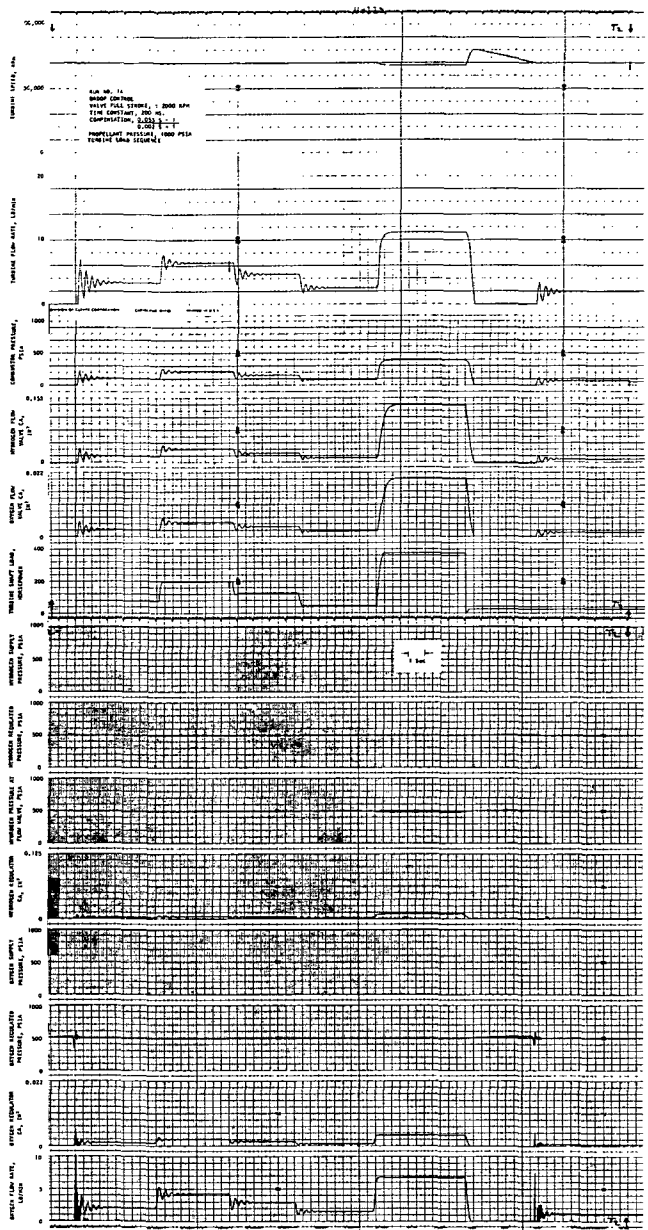
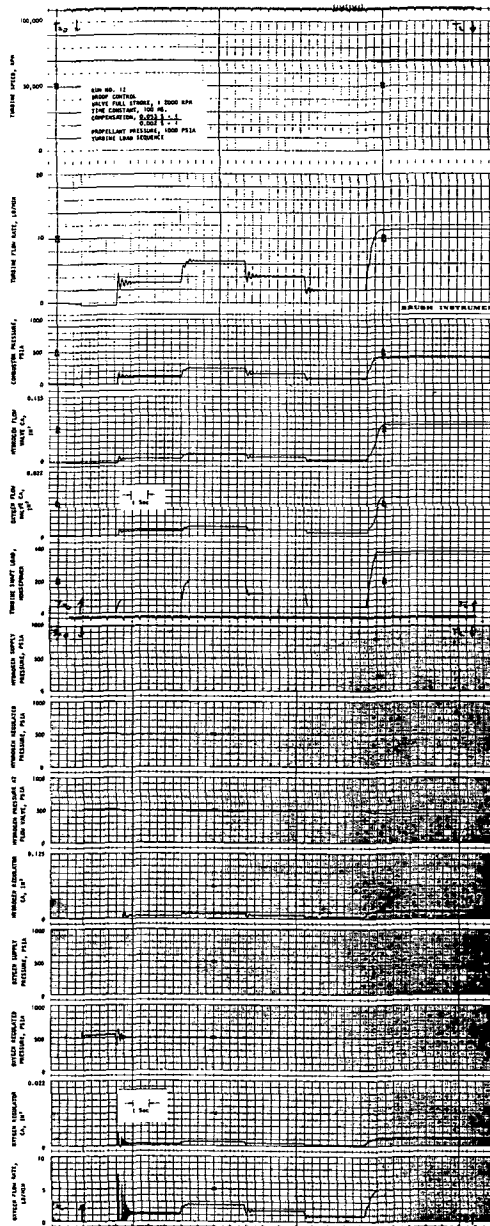

Figure 7-12



b  
Figure 7-12





total duration of approximately 1 1/2 sec before being damped out. Here, again, the flow oscillations do not impact upon APU performance, but the oscillations definitely have an adverse effect upon the required number of valve cycles for a specific mission.

Figure 7-12b shows a definite improvement in turbine speed stability when the valve time constant is reduced to 100 msec. Also, the 1 1/2-sec duration of system oscillations is reduced to approximately 1/2 to 3/4 sec. Figure 7-12c shows system performance when the valve response time is further reduced to 50 msec. It is seen that the flow oscillations are virtually eliminated. Control stability was accomplished at the expense of a valve assembly with a response of 50 msec. By comparison, the droop control with 50-msec valving does not yield as smooth operation as the integrating control concept based on a valve response requirement of only 200 msec. Figure 7-12d illustrates that the introduction of spike loads to the programmed load profile again caused the system to exhibit oscillations, even with the 50-msec valve response. Comparison of this run with those shown in either Figure 7-9b or 7-10b, indicates that the integrating control provides the more stable control of the two concepts studied. The integrating control can provide the improved stability with valve components that are designed to less rigorous requirements than is possible with the droop control.

Figures 7-13a and b show the results of operating the droop control in the startup mode. Here the valve response was varied from 50 to 200 msec. The rated turbine speed is reached in approximately 1 1/2 sec based on 50-msec valve response. The flow oscillations occur for a period of approximately 1/2 sec. When the valve response is relaxed to 200 msec, the startup transient is increased to approximately 2 sec, and the flow oscillations occur for a period of 2 1/2 sec. Again, comparison of these two runs with the stable runs shown in either Figure 7-9c or 7-10b affirms the desirability of the integrating control concept over the droop control.

## CONCLUSIONS

The analog studies have indicated that either the integrating or droop control concept can provide stable control if the proper component response and control circuitry are used. Figures 7-14 and 7-15 summarize the studies in terms of specific parameter effects on the time for the flow oscillation to decay. The data indicate that the integrating control can easily provide complete flow stability, whereas the droop control would require fast-response valves in order to insure reasonable stability.

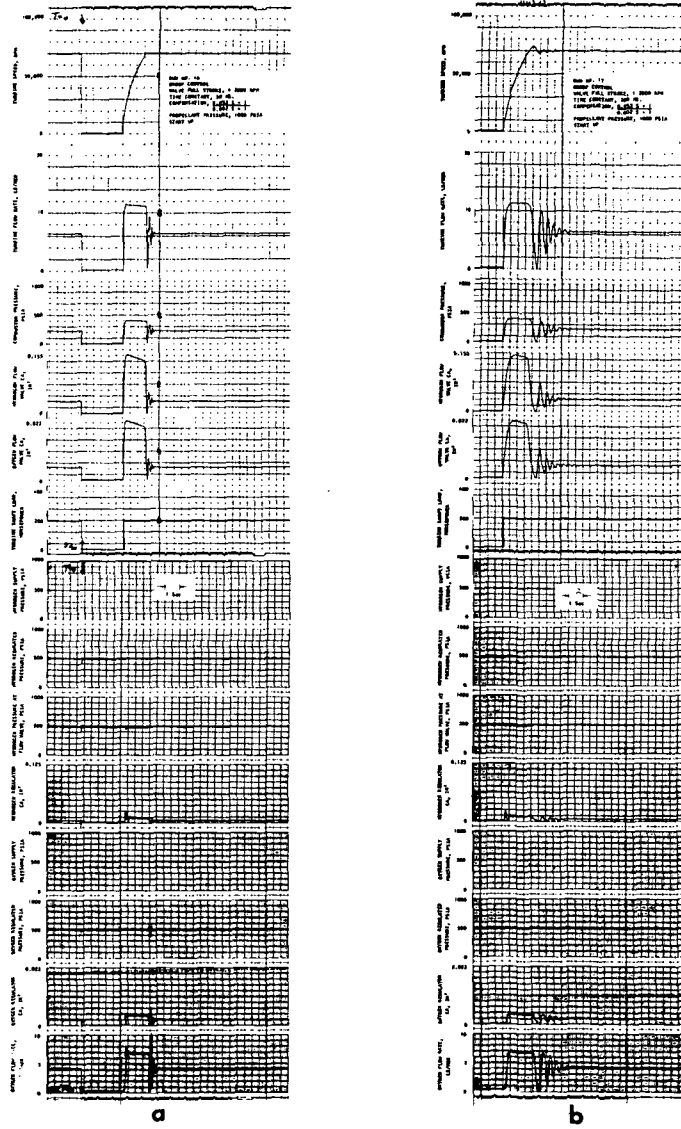

Figure 7-13

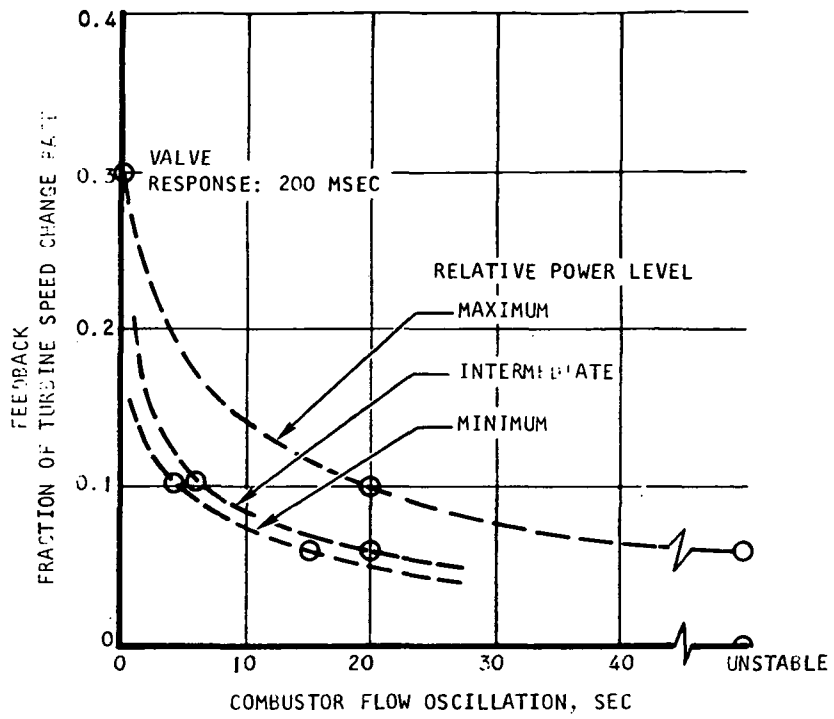

Figure 7-14. Integrating Control--Effect of Feedback Upon Stability of Reactant Flow

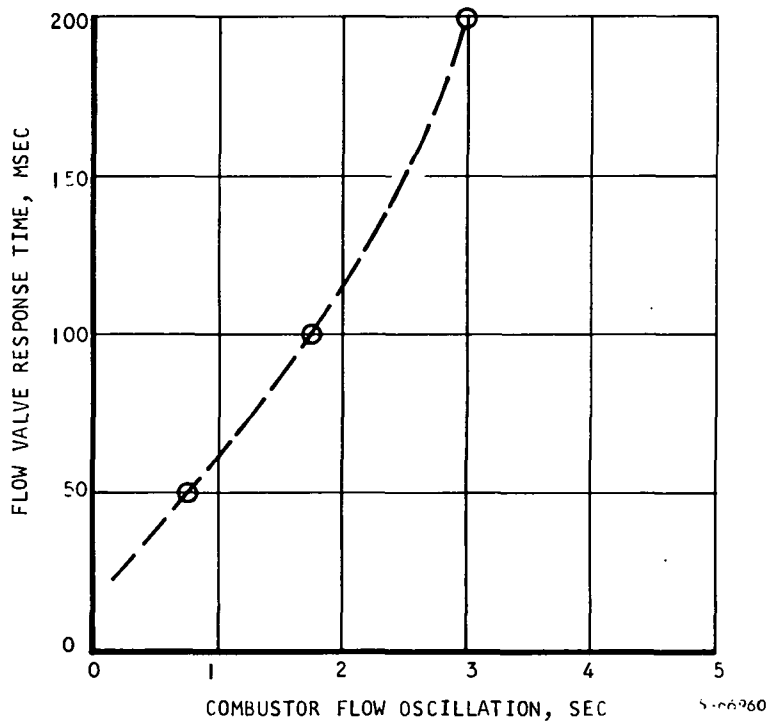

Figure 7-15. Droop Control--Effect of Valve Response Upon Stability of Reactant Flow

## SECTION 8

### RELIABILITY

#### INTRODUCTION

The reliability evaluation was conducted at the system level and at the component level. System level studies highlight component interrelationships for fault determination. This leads to identification of instrumentation and monitoring requirements and system level checkout definitions. The component level studies pinpoint the individual component fault characteristics and define areas of potential weakness. These studies are described separately below.

#### SYSTEM RELIABILITY EVALUATION

System level functional studies result in the identification of a fault logic tree that can be used to develop requirements for monitoring and fault detection instrumentation. Figure 8-1 shows the fault logic tree for loss of the APU function. A gearbox failure or a loss of input to the gearbox are the two reasons for APU function loss. Failure and condition combinations leading to failure are developed in this fault logic tree.

Figure 8-1 illustrates several points that join major branches of the failure logic tree. These points represent locations for monitoring system operation and to detect failure conditions.

Table 8-1 contains three lists of instrumentation for the APU. The first column lists the instrumentation incorporated into the baseline design for the purpose of system control. These functions are required to make the system function in a normal way, responding to variations in load and reactant input conditions. The second column lists the minimum instrumentation needed to evaluate the failure condition of the unit. This list corresponds to the instrumentation shown on the fault logic tree of Figure 8-1. The four parameters to be monitored to determine the requirement for system shutdown are turbine overspeed, turbine inlet overtemperature, hydrogen pressure, and lube oil temperature. The instrumentation points listed are seen to coincide with the junction of fault branches, thereby allowing a single sensor to serve as indicator for failure of a total function.

The parameters of turbine inlet temperature and turbine speed are closely related since they both serve to define the existence of an input to the gearbox. An overtemperature or overspeed condition is cause for shutdown of the APU to prevent the possibility of generating secondary failures, which may result in damage to related subsystems.

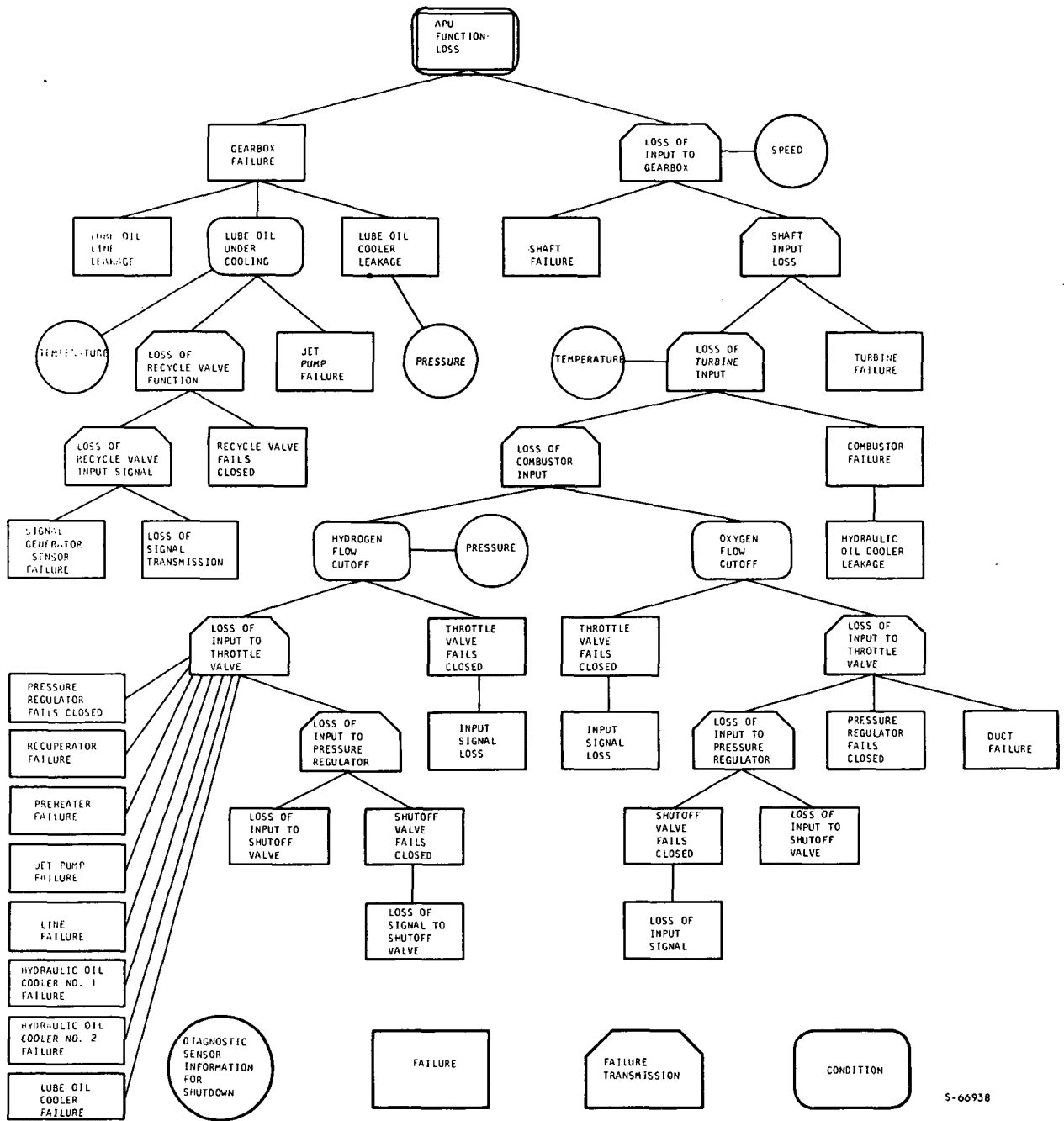

Figure 8-1. Fault Logic Tree

TABLE 8-1

AUXILIARY POWER UNIT INSTRUMENTATION

Sensing Function in Baseline System for System Control	Minimum Data for Fail-Operational Shutdown	Information for Operational Diagnosis and/or Checkout
Recycle hydrogen temperature  Turbine inlet temperature  Turbine speed   Recycle valve position  Flow control valve position	Turbine underspeed  Turbine overspeed  Turbine inlet overtemperature   Hydrogen pressure  Lube oil temperature  Lube oil pressure  Controller internal monitoring	Recycle hydrogen temperature  Turbine inlet temperature  Turbine speed   Recycle valve position  Flow control valve position  Oxygen pressure  Hydrogen pressure  Lube oil temperature  Lube oil pressure

Hydrogen pressure is significant to the decision for APU shutdown. The APU may operate in a safe manner with only hydrogen flowing, although the performance is obviously very poor. However, if hydrogen flow is lost for any reason during a run, and only oxygen is flowing into the combustor, severe oxidation of the combustor, turbine, and recuperator may result. Monitoring of the hydrogen pressure is a simple approach to determining the presence of hydrogen in the flow system, and therefore the continued safe operation of the APU.

A gearbox failure may be determined by monitoring the lube oil temperature. Incipient gear or bearing failures will cause added heat rejection in the gearbox, resulting in increased lube oil temperatures. Monitoring the lube oil temperature directly in the gearbox allows measurement of temperature increase caused by loss of the lube oil flow, which is another reason to initiate APU shutdown. Lube oil temperature monitoring in a lube oil line would not yield this information for shutdown decision making.

The set point for the instruments used to initiate system shutdown will be evaluated in light of the normal transient behavior of the APU caused by normal load and inlet condition variations. Trip points set too far from nominal performance variations may not provide adequate safeguard to the APU and/or to other related subsystems, whereas, trip points set too close to the nominal operation of the system parameters may cause shutdown when no failure condition exists.

Information from other subsystems may also be used to initiate APU shutdown. The circuit protection devices in the electrical distribution subsystem may provide the shutdown signals.

Similar shutdown information may come from the hydraulic components in the hydraulic loop as a result of fault detection/isolation in this area.

If APU shutdown is required, electrical power to the shutoff valves will be removed. The valves will close and the APU will come to a normal off condition. A signal will be initiated to show the status of the APU, which can be displayed to the crew, recorded, and/or transmitted to ground.

The last column in Table 8-1 lists the APU parameters that are candidates for monitoring to determine the operational status of the system during ground checkout, or for purposes of monitoring and recording during a flight. Monitoring these parameters over the range of reactant inlet conditions, and over an exercised load profile, will determine total system health and aid in verification of maintenance requirements.

## COMPONENT RELIABILITY EVALUATION

Figure 8-2 presents the fault logic for individual component/functions of the APU. These logic trees define the operational characteristics of the individual function shown in the component drawings, and further defined in the specification of each part. The detailed fault trees supplement the system level logic tree by presenting the detail leading to a specific fault or failure condition. The failures identified in the figures for components result in the normal shutdown of the APU as described earlier in this section.

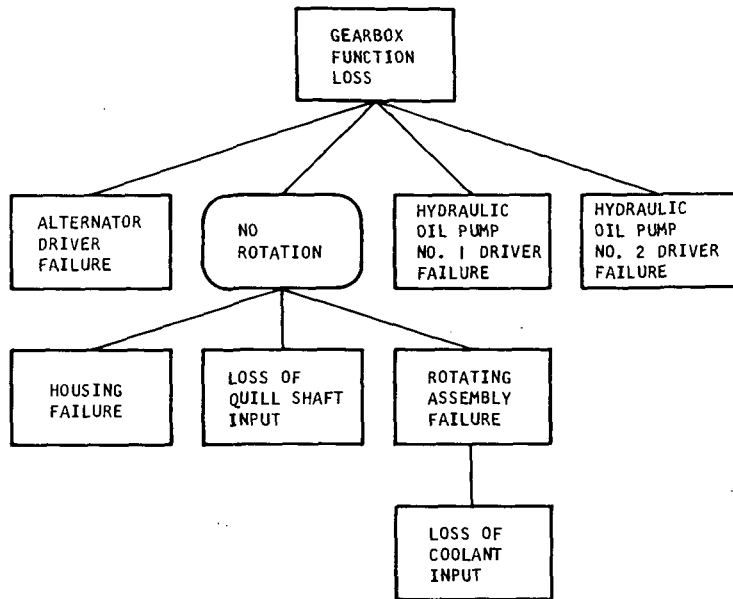

GEARBOX

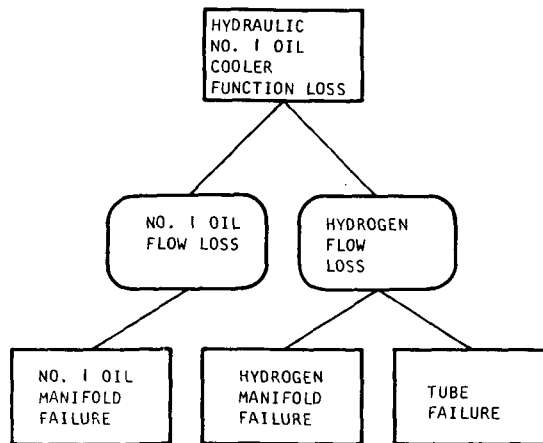

HYDRAULIC NO. 1 OIL COOLER

Figure 8-2. Individual Fault Logic Trees.

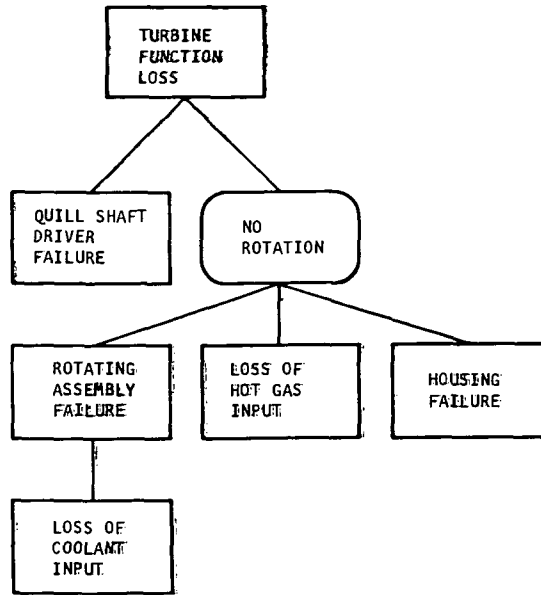

TURBINE

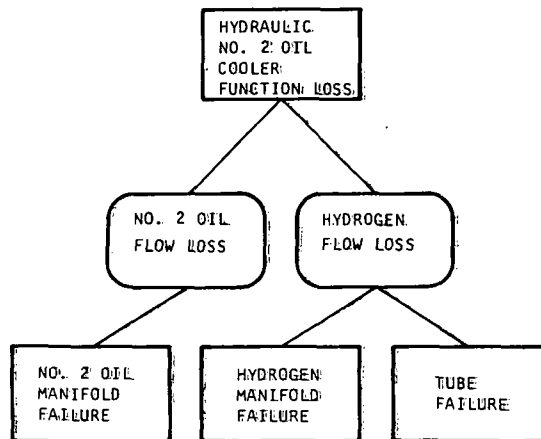

HYDRAULIC NO. 2 OIL COOLER

Figure 8-2. Continued

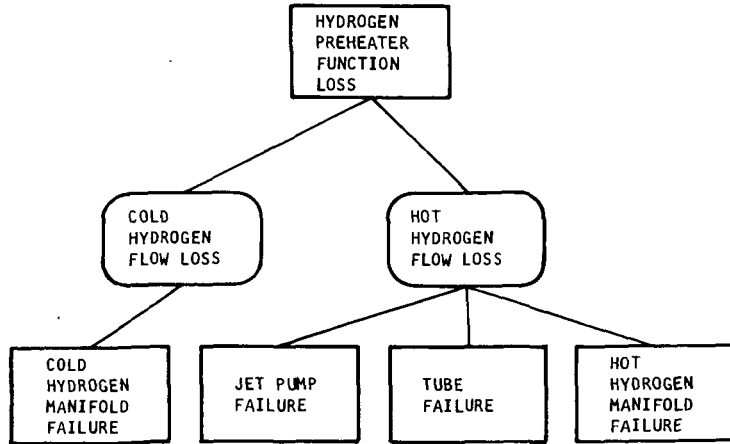

HYDROGEN PREHEATER

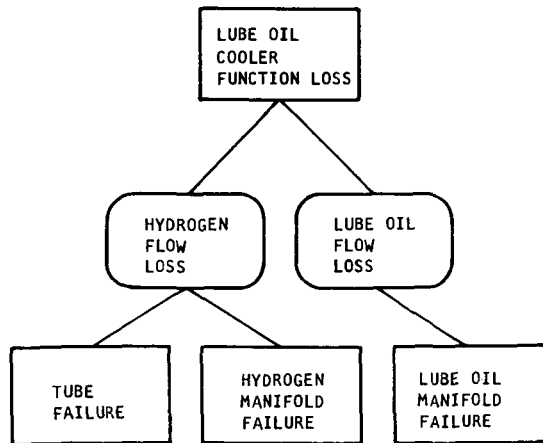

LUBE OIL COOLER

Figure 8-2. Continued.

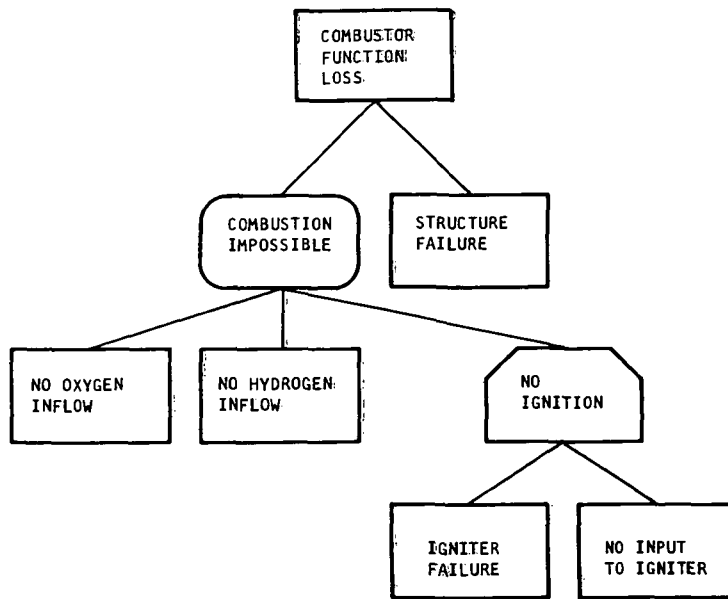

COMBUSTOR

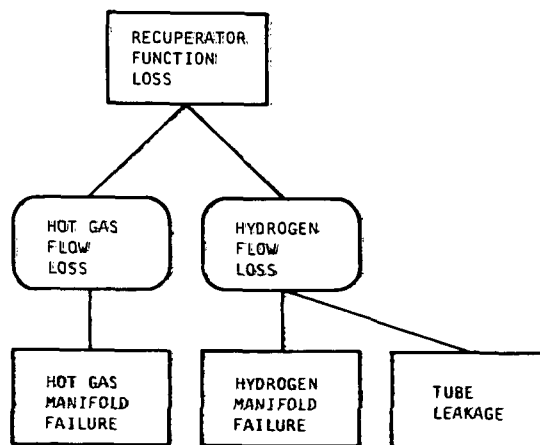

RECUPERATOR

L-66937

Figure 8-2. Continued.

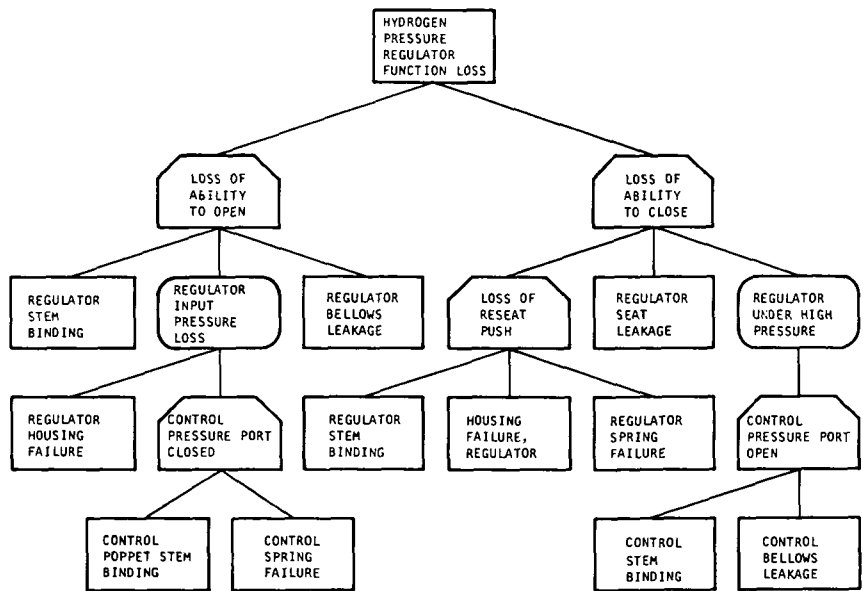

HYDROGEN PRESSURE  
REGULATOR

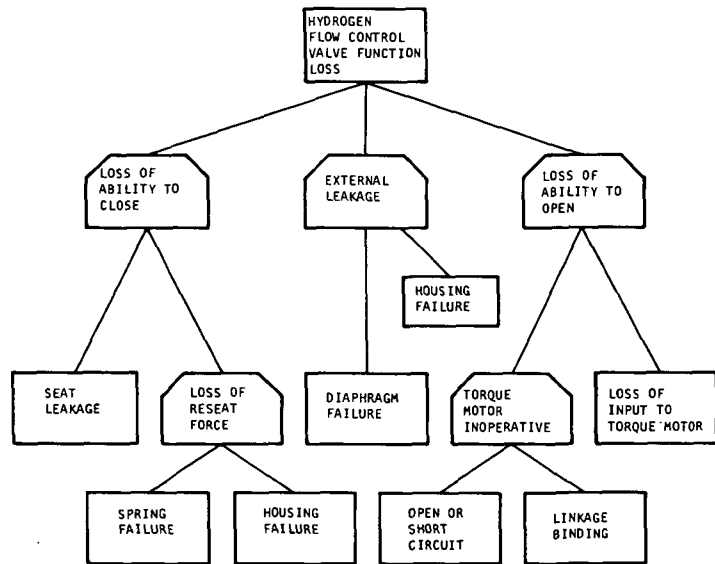

HYDROGEN FLOW  
CONTROL VALVE

Figure 8-2. Continued.

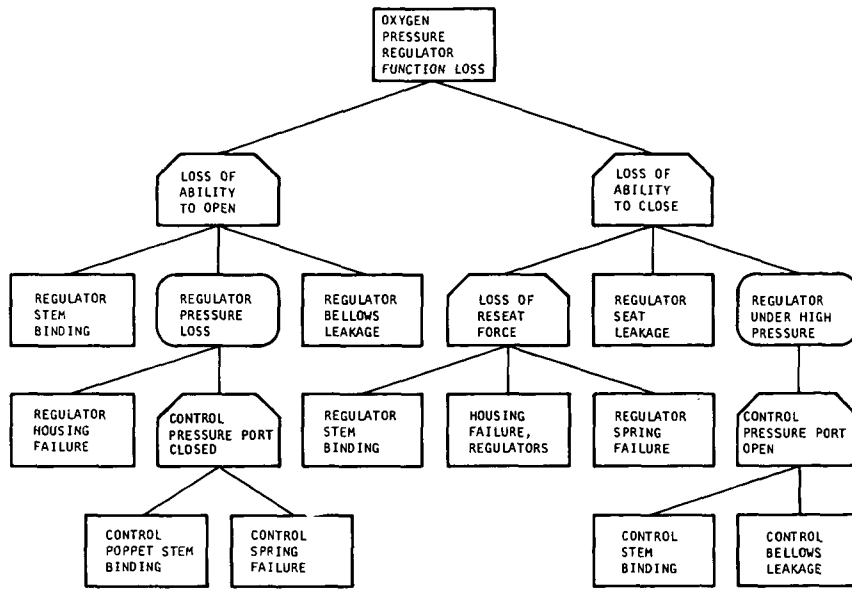

OXYGEN PRESSURE  
REGULATOR

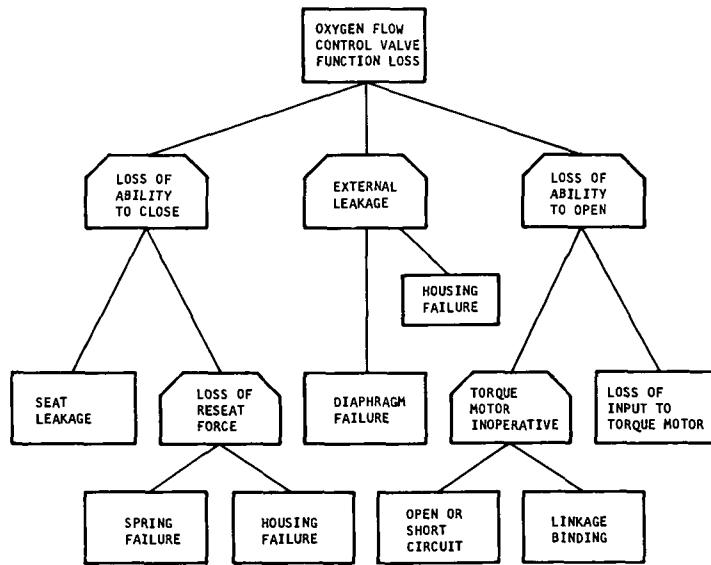

OXYGEN FLOW  
CONTROL VALVE

Figure 8-2. Continued.

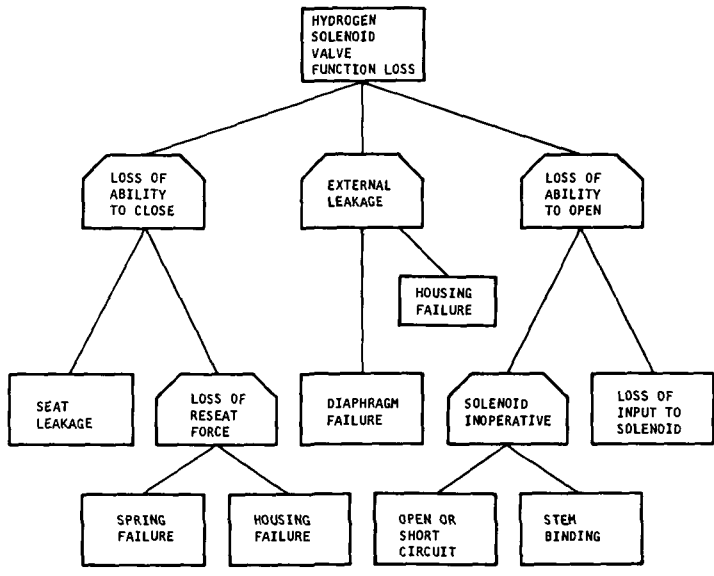

HYDROGEN SOLENOID VALVE

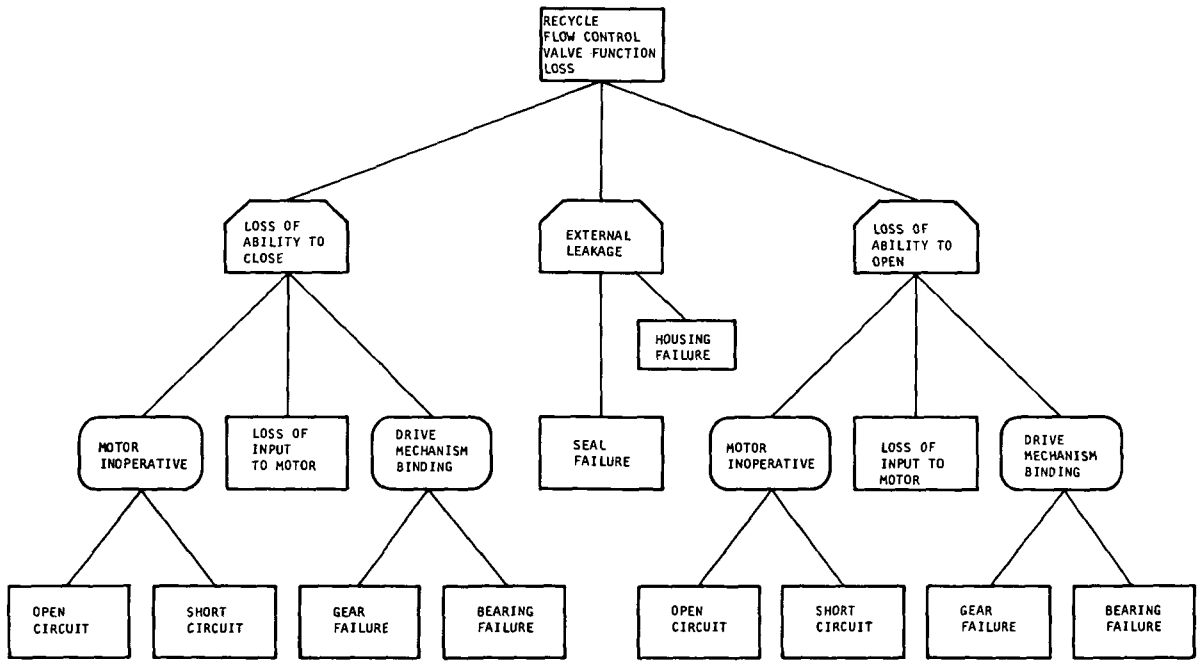

RECYCLE FLOW CONTROL VALVE

Figure 8-2. Continued.

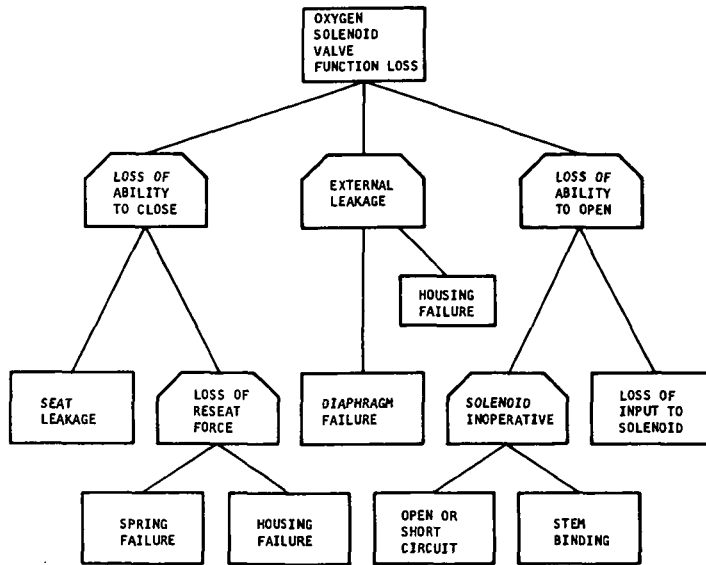

OXYGEN SOLENOID VALVE

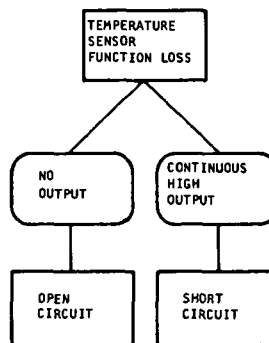

TEMPERATURE SENSOR

Figure 8-2. Concluded.

L-66942

NATIONAL AERONAUTICS AND SPACE ADMINISTRATION  
WASHINGTON, D.C. 20546

OFFICIAL BUSINESS  
PENALTY FOR PRIVATE USE \$300

FIRST CLASS MAIL

POSTAGE AND FEES PAID  
NATIONAL AERONAUTICS AND  
SPACE ADMINISTRATION



POSTMASTER: If Undeliverable (Section 158  
Postal Manual) Do Not Return

*"The aeronautical and space activities of the United States shall be conducted so as to contribute . . . to the expansion of human knowledge of phenomena in the atmosphere and space. The Administration shall provide for the widest practicable and appropriate dissemination of information concerning its activities and the results thereof."*

—NATIONAL AERONAUTICS AND SPACE ACT OF 1958

## NASA SCIENTIFIC AND TECHNICAL PUBLICATIONS

**TECHNICAL REPORTS:** Scientific and technical information considered important, complete, and a lasting contribution to existing knowledge.

**TECHNICAL NOTES:** Information less broad in scope but nevertheless of importance as a contribution to existing knowledge.

**TECHNICAL MEMORANDUMS:** Information receiving limited distribution because of preliminary data, security classification, or other reasons.

**CONTRACTOR REPORTS:** Scientific and technical information generated under a NASA contract or grant and considered an important contribution to existing knowledge.

**TECHNICAL TRANSLATIONS:** Information published in a foreign language considered to merit NASA distribution in English.

**SPECIAL PUBLICATIONS:** Information derived from or of value to NASA activities. Publications include conference proceedings, monographs, data compilations, handbooks, sourcebooks, and special bibliographies.

**TECHNOLOGY UTILIZATION PUBLICATIONS:** Information on technology used by NASA that may be of particular interest in commercial and other non-aerospace applications. Publications include Tech Briefs, Technology Utilization Reports and Technology Surveys.

*Details on the availability of these publications may be obtained from:*

**SCIENTIFIC AND TECHNICAL INFORMATION OFFICE  
NATIONAL AERONAUTICS AND SPACE ADMINISTRATION  
Washington, D.C. 20546**