

## 23

**BREATHING METABOLIC SIMULATOR**

R. G. Bartlett, C. M. Hendricks, and W. B. Morison  
Federal Systems Division  
International Business Machines Corporation  
Gaithersburg, Md.

**INTRODUCTION**

The NASA Office of Advanced Research and Technology and the Bureau of Mines have jointly funded the development of a breathing metabolic simulator (BMS) under contract NASW-2032. This BMS simulates all of the breathing and metabolic parameters required for complete evaluation and test of life support and resuscitation equipment. It is also useful for calibrating and validating mechanical and gaseous pulmonary function test procedures. Breathing rate, breathing depth, breath velocity contour, oxygen uptake, and carbon dioxide release are all variable over wide ranges simulating conditions from sleep to hard work with respiratory exchange ratios (R) covering the range from hypoventilation to hyperventilation. In addition, all of these parameters are remotely controllable to facilitate use of the device in hostile or remote environments. The exhaled breath is also maintained at body temperature and a high humidity. The simulation is accurate to the extent of having a variable functional residual capacity (FRC) independent of other parameters.

**SIMULATION DESIGN CONSIDERATIONS**

The following breathing characteristics were considered in implementing the BMS design.

**Breathing Rate**

The breathing rate adjustment provided by the BMS covers the rates that occur in the human, ranging from rest to hard work conditions. Although this wide range is available, most subjects would fall into a much narrower range.

**Breathing Depth**

The breathing depth adjustment provided by the BMS covers a wide range up to 3 liters/breath. Although an individual breath may exceed 3 liters under some conditions, the depth under continuous hard exercise should not exceed simulator capacity. Individual breath (tidal volume) is normally on the order of 0.5-0.6 liter under rest conditions, and it increases with activity. The minimum simulator capacity includes this normal rest capacity. Selection of the appropriate combination of breathing rate and depth will allow the simulation of a wide range of breathing activity.

For special applications the breathing depth can be made greater than 3 liters. It can be made to simulate a full vital capacity (e.g., 6 liters).

**Velocity-Time Waveform**

The breath velocity pattern in the human is not generally represented by a true sinewave. It may vary from a slightly blunted sinewave under some conditions to a drastic variation under conditions

encountered during forced exhalation. To provide a faithful simulation, a waveform control is provided, allowing a wide range of variations from a basic sinewave.

### **Functional Residual Capacity**

The FRC is the volume of air remaining in the lungs at the end of normal exhalation. To obtain faithful simulation, the FRC must remain constant for breathing rate or depth changes or both. It is also necessary to have the FRC variable so that individuals with different FRCs can be simulated. Both of the conditions are provided by the BMS.

### **Exhaled Breath Temperature and Humidity**

In the human the exhaled breath is at body temperature and, except for conditions of extremely hard breathing, is at 100 percent relative humidity. Both of these conditions are provided by the BMS.

### **Oxygen Consumption**

The simulation of the metabolic range between sleep and medium hard work requires a variable oxygen consumption rate. The range of the adjustable consumption rate of the BMS includes these conditions. For special applications the BMS can be made to simulate maximum oxygen consumption rates for the human undergoing maximum physical work.

### **Carbon Dioxide Production**

The amount of carbon dioxide produced in the human is related to the amount of oxygen consumed. This ratio is 0.707 if the fuel is fat and is 1.0 if the fuel is carbohydrates. This ratio, when referenced to tissue metabolic activity, is referred to as the respiratory quotient ( $RQ$ ). When referenced to the ratio of gases in the exhaled breath (as in the BMS), it is referred to as the respiratory exchange ratio ( $R$ ). (This differentiation is made because an individual may be underbreathing or overbreathing, markedly affecting the amount of carbon dioxide removed from the body and thus the value of  $R$ .) To simulate these conditions, the BMS provides a range of carbon dioxide/oxygen ( $R$ ) wider than the normal range of 0.7 to 1.0.

## **HARDWARE FUNCTIONAL DESCRIPTION**

The BMS has been implemented in a configuration that may be described as consisting of three subsystems: temperature/humidity, breathing, and metabolism. These subsystems are shown in the simplified system schematic (fig. 23.1) and are then described individually. Performance specifications are shown in table 23.1.

### **Temperature/Humidity Subsystem (fig. 23.2)**

*Functions.* Incoming air from the artificial trachea is fed into an exchange box, where it is blocked from entering the humidity chamber by a check valve. The air then passes through another check valve and enters the main connection to the top of the bellows during bellows expansion.

Outgoing (exhaled) air comes from the main connection to the top of the bellows during bellows contraction. The air passes through a check valve and enters the input end of the humidity chamber. The air entering the chamber displaces air from the output end of the chamber through a check valve, where it enters the exchange box and exits to the artificial trachea.

*Features.* The check valves and exchange box are used to control air flow direction and to permit a single connection to the artificial trachea.

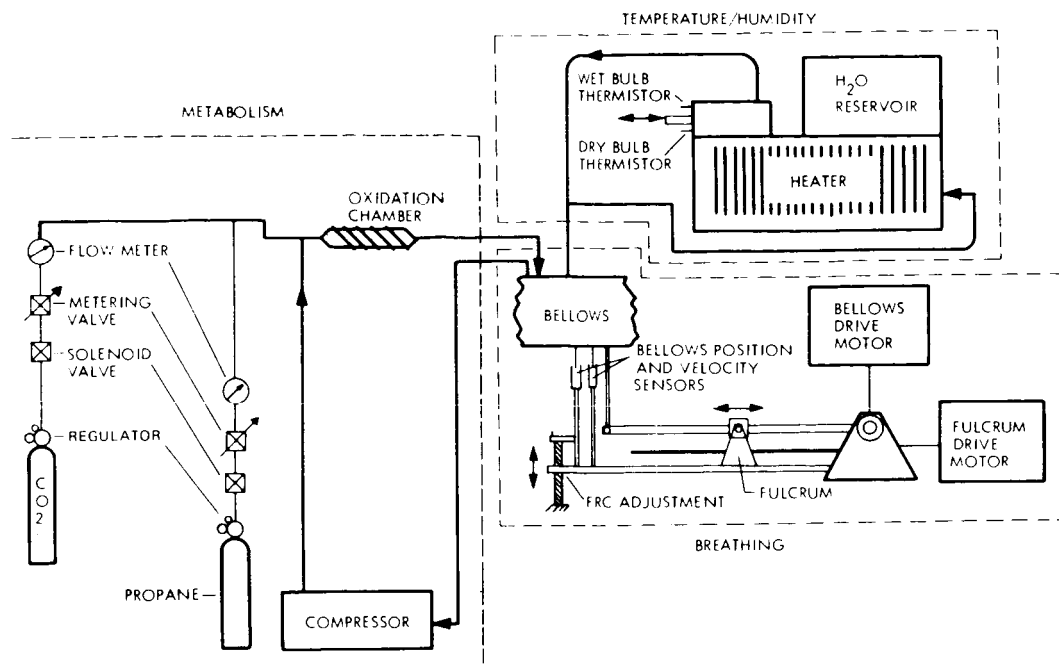

Figure 23.1 Simplified system schematic.

Table 23.1 Performance specifications.

*Breathing Simulation Subsystem*

Rate adjustment	5-60 breaths/minute
Depth adjustment	400-3000 ml/breath (up to 6000 ml for special applications)
FRC adjustment	1.7 - 4.0 liters, constant with rate, depth and wave-form changes
Velocity-time waveform	Variable, from sinewave to other shapes as obtained via 12 separately controllable velocity regions within a breath cycle

*Humidity/Temperature Subsystem*

Humidity	Gas exhaled with a humidity between 96 percent and 100 percent through medium high volumes, to 90 percent for extreme high volumes
Temperature	Gas exhaled with a temperature controlled to 98.6° F within ± 2° F for all volumes

*Metabolic Simulation Subsystem*

O <sub>2</sub> consumption rate	Adjustable within the range of 250 to 2000 ml/min (up to 3000 ml/min for special applications)
CO <sub>2</sub> production rate	Adjustable within a range to produce a respiratory exchange ratio of 0.6 to 1.5.

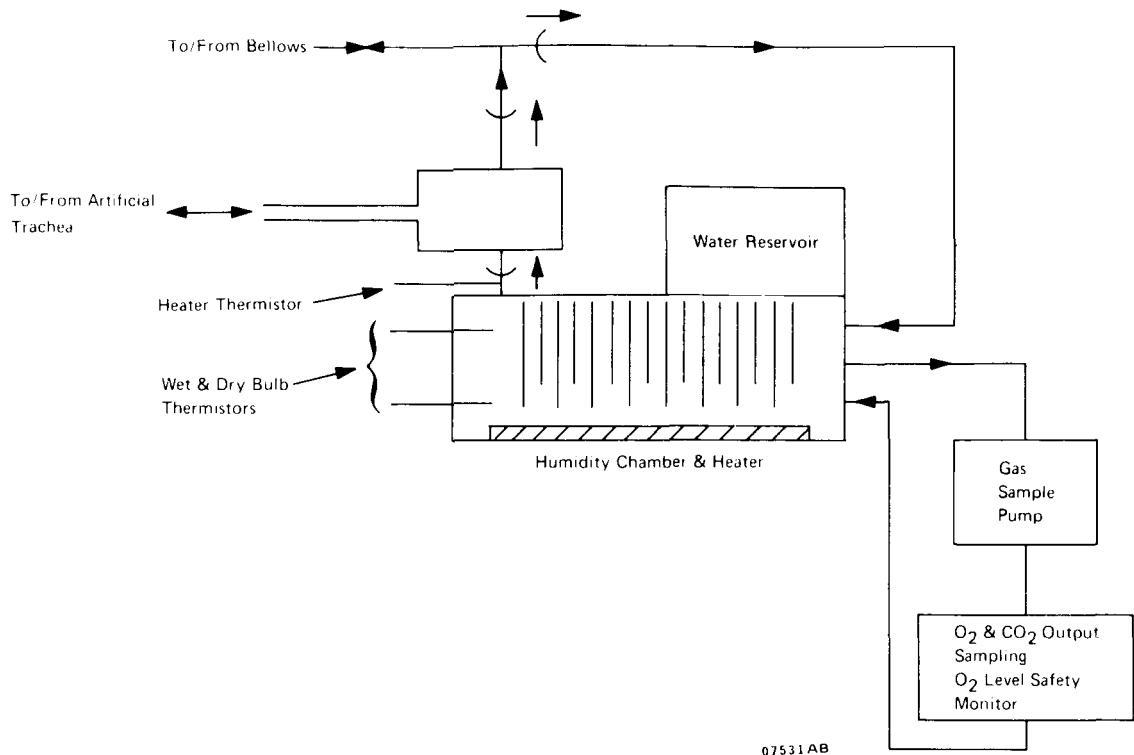

Figure 23.2 Temperature/humidity subsystem.

The humidity chamber is used to add moisture to the exhaled air and to maintain temperature within specified limits. The moisture transfer media (surgical sponges) remain saturated with water from a separate reservoir. (Actual humidity is also affected by the dwell time of a breath inside the chamber.) Temperature maintenance, accomplished by a heater blanket in the bottom of the chamber, is controlled by a thermistor placed in the path of the chamber output. Heater power is remotely controlled by the appropriately labeled switch on the control unit.

This subsystem also contains sensors for monitoring the characteristics of the air to be exhaled. Wet- and dry-bulb thermistors placed in the output end of the chamber can be monitored by positions 5 and 4, respectively, of the control unit digital voltmeter. A gas sample line connected to the chamber input end allows a sample pump, operating when the carbon dioxide analyzer is on, to extract gas samples, that are fed to the sensors of an oxygen analyzer and a carbon dioxide analyzer and returned to the chamber. The readout of these analyzers is accomplished on the control unit. (These analyzers can be calibrated from separate gas inputs, as described in detail in the operations manual.)

### Breathing Subsystem (Fig. 23.3)

*Functions.* This subsystem controls expansion and contraction of a bellows to draw air from and expel air to the temperature/humidity subsystem. The bellows motion is independently variable in rate, magnitude of periodic motion and volume remaining at point of minimum periodic volume change. The periodic motion of the bellows is accomplished by a bellows drive motor operating a crankshaft/connecting rod combination through a 30:1 gear reduction. The drive motor speed is

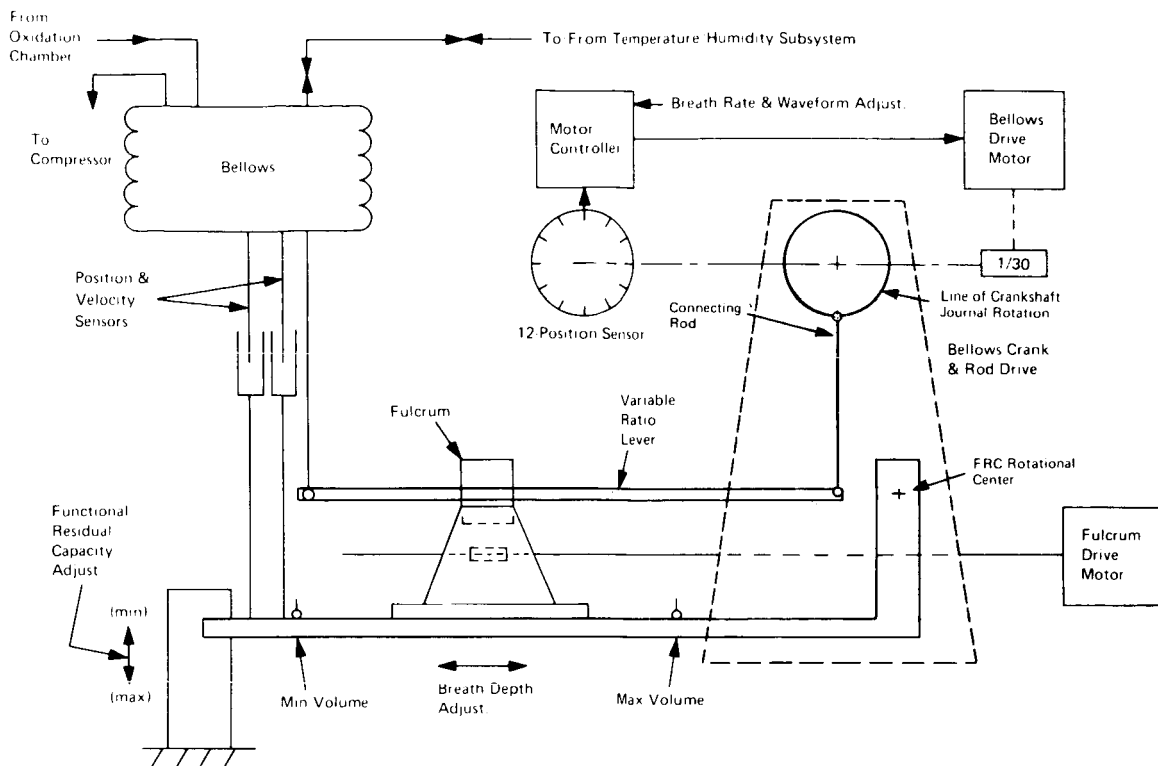

**Figure 23.3** *Breathing system.*

varied by means of a motor controller. Long-term variations, greater than one crankshaft revolution, correspond to changes in breathing rate and are varied from the control unit by means of the labeled control. Short-term variations, within one crankshaft revolution, correspond to changes in breath waveform and are varied by the individual settings of 12 waveform controls on the control unit. Each control is effective during one-twelfth of a crankshaft revolution as determined by a 12-position read switch.

Connecting rod motion is transmitted to the bellows by means of a lever arm operating on a movable fulcrum. Fulcrum motion along the lever arm varies the level arm ratio corresponding to changes in breath depth. This motion is accomplished by means of a lead screw from the fulcrum drive motor, which is in turn controlled by the bidirectional fulcrum switch on the control unit. Fulcrum driving toward minimum and maximum volume per breath is indicated on the control unit by the right and left limit lights illuminating, respectively. (The lights will extinguish if a limit is encountered while driving.) Fulcrum motion normal to the lever arm (i.e., moving the position of the bottom of the bellows for a fixed crank position and lever arm ratio) will change the minimum bellows volume obtainable through periodic motion. This corresponds to a functional residual capacity adjustment and is controlled by a manual screw adjustment on the support for the fulcrum base. This adjustment has a scale calibrated in FRC volume in liters adjacent to the screw.

*Features.* The top of the bellows contains two separate gas lines to provide an output to the compressor of the metabolism subsystem and to receive the output of this subsystem.

Two separate magnetic flux type sensors are mounted between the bottom of the bellows and the adjustable support for the fulcrum base. These sensors measure position and velocity between

mountings (thus sensing breath characteristics independent of FRC adjustment) and are input to the oscilloscope in the control unit, where either may be selected for waveform display.

### Metabolism Subsystem (fig. 23.4)

*Functions.* This subsystem is used to control  $R$ . Since  $R$  is a carbon dioxide to oxygen ratio, metabolism is simulated by consuming oxygen and producing carbon dioxide. This is accomplished by oxidizing propane and adding varying amounts of carbon dioxide in the following manner.

Air is drawn from the top of the bellows by a compressor. The compressed air output is then fed to an accumulator used to eliminate surging caused by bellows motion. The accumulator output is connected to an adjustable orifice used to preset the flow rate for more than sufficient air for all oxidation conditions; the accumulator is then connected to a gas line input to the oxidation chamber. A size D tank of CP grade propane is fitted with a manual regulator (set to 15 psi). The regulator output is connected to a solenoid shutoff valve controlled by the manual switch on the control unit (and the series safety circuitry, discussed later). The solenoid valve output is connected to a remotely adjustable metering valve (controlled by valve enable and carbon dioxide adjustment on the control unit). The metering valve output is connected to a flow meter sensor (the flow meter is located on the control unit panel) and finally to the oxidation chamber input line. A size D carbon dioxide tank is fitted with a duplicate of the propane controls (except safety circuit not required) and also connected to the oxidation chamber input line.

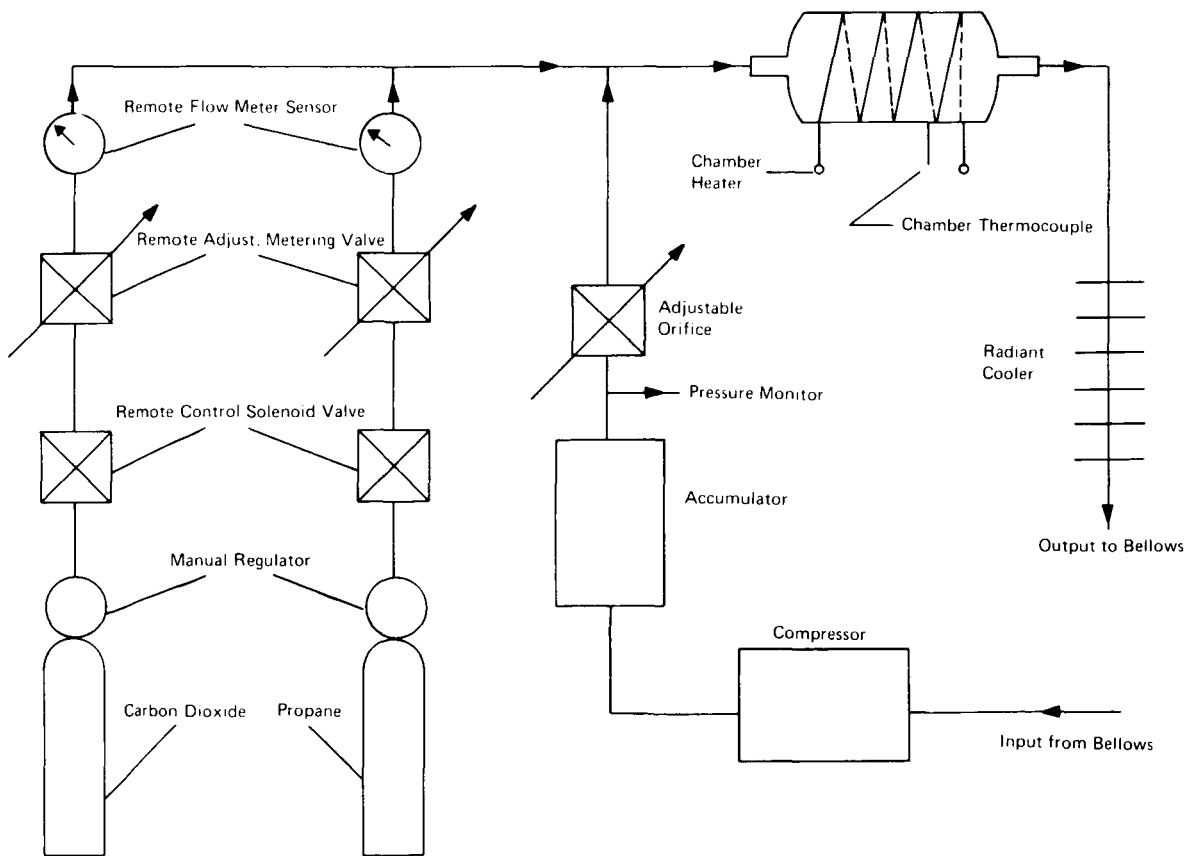
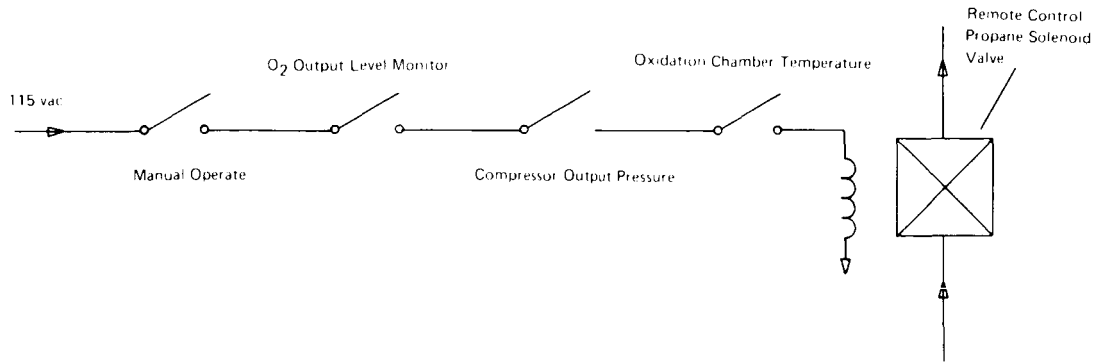

Figure 23.4 Metabolism subsystem.

The oxidation chamber is an expanded line area (made of quartz) containing a probe input for a chamber thermocouple and surrounded by an encased insulated heating element. Power to the heater is manually controlled (ON/OFF only) from the control panel combustion heater switch and maintains the chambers temperature above that required for oxidation of propane. In operation, complete oxidation occurs with the chamber output having a carbon dioxide/oxygen ratio that is variable, dependent upon the carbon dioxide and propane flow rates into the chamber (air input is a constant). The chamber output is fed to a radiant series cooler to reduce temperature to a safe level and then is returned to the top of the bellows.

*Features.* A safety circuit (fig. 23.5) used to control propane flow will not allow the solenoid valve to be opened unless the proper oxidation conditions exist. The conditions monitored are the oxygen output level in the temperature/humidity subsystem, the compressor output pressure at the accumulator, and the chamber temperature at the output end.



**Figure 23.5** Propane safety control circuit.

The chamber thermocouple output can be monitored (position 3 of the digital voltmeter) to determine temperature during preheating or other conditions as desired. Installation considerations are shown in table 23.2. Figures 23.6 and 23.7 are photographs of the device delivered under contract funded by NASA.

**Table 23.2** Installation considerations.

*Physical Characteristics*

Control unit	Size     60 in. H × 20 3/8 in. W × 19-7/8 in. D (including casted support cart) Weight approximately 200 lb
Simulator unit	Size     59 in. H × 18 in. W × 25-1/2 in. D Weight approximately 250 lb
Interconnection	
Electrical cables	4, with disconnects
No other interconnections required.	Length - 8 ft

**Table 23.2** *Installation considerations. (Concluded)*

*Electrical Input Characteristics*

Voltage	115 vac (60 cy) single phase, with ground
Current	Control unit input cable - less than 20 A Simulator unit input cable - less than 20 A

*Safety Consideration*

Contains combustible gas and, for safety, should be used only in a well ventilated area.

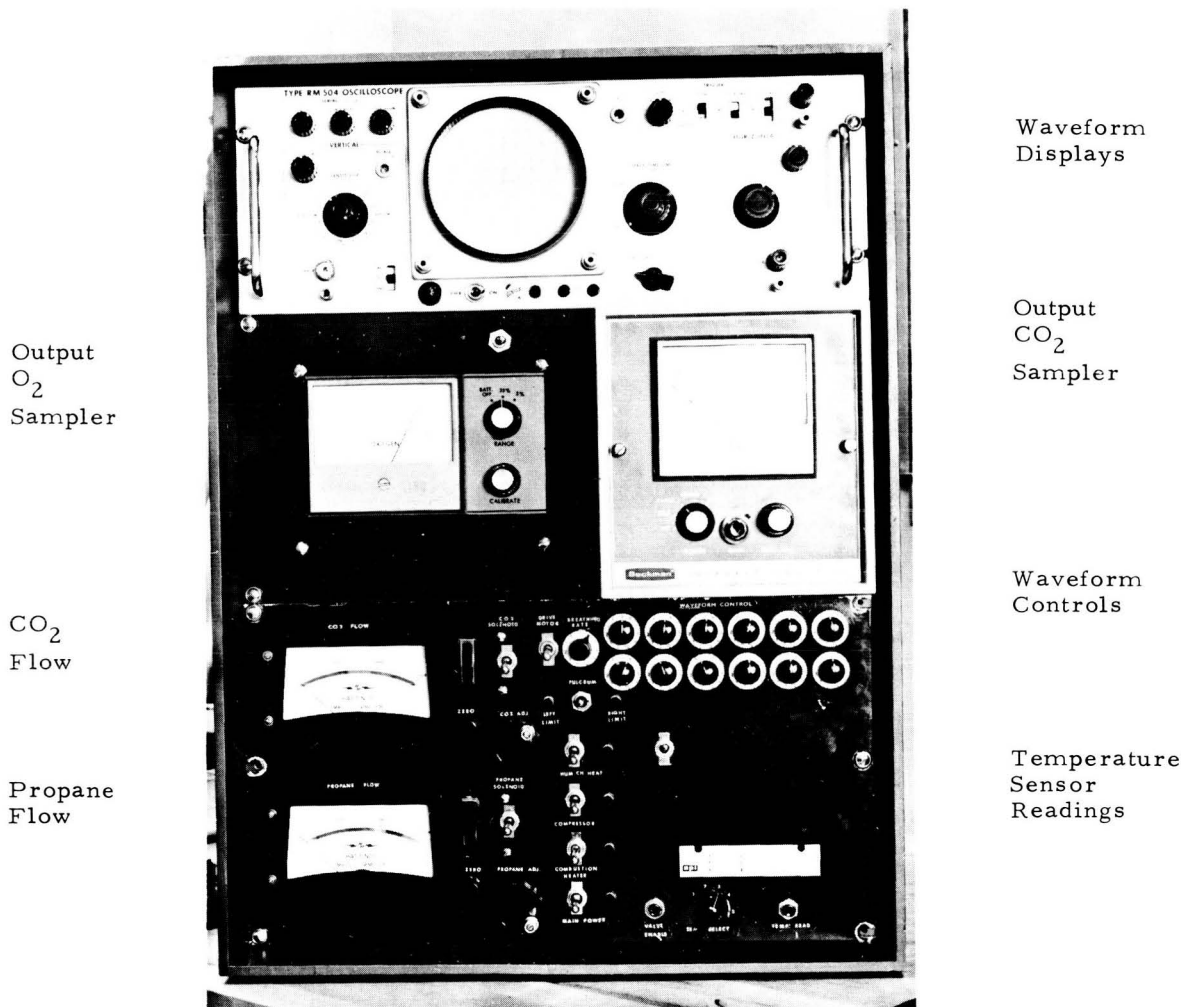

**Figure 23.6** *Control unit functions.*



Temp-  
Humidity

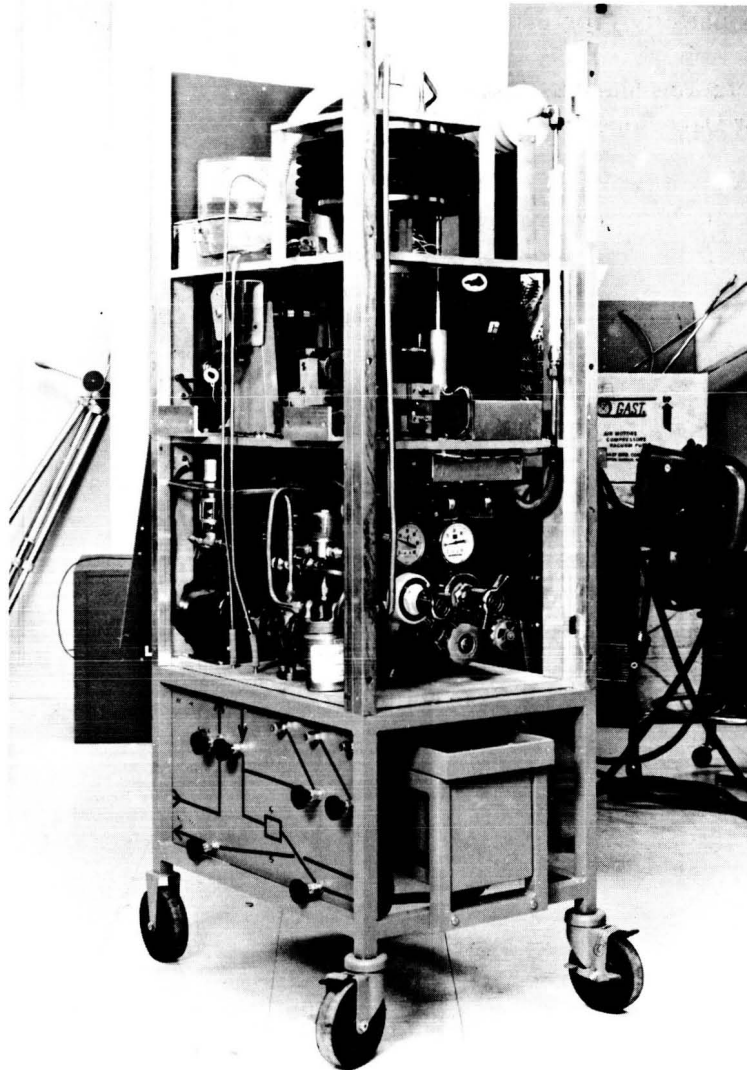

Breathing  
Mechanism

Metabolic  
Functions

Output  
Sampling  
&  
Calibration

Figure 23.7 Simulator unit functions.

The following expendables are required for operation:

Carbon dioxide	Air products size D tank (4 by 17 in.)
Propane (CP)	Air products size D tank (4 by 18 in.)
Distilled water	Reservoir capacity approximately 2.33 quarts
Surgical sponge	Parke-Davis gauze 4 by 8 in. approximately (one package of 100 required for replacement)

## BIBLIOGRAPHY

1. Anon.: First Quarterly Progress Report BMS, April 27, 1970 to July 27, 1970 (IBM No. 70-A95-0001)

2. Anon.: Second Quarterly Progress Report BMS, July 27, 1970 to October 27, 1970 (IBM No. 70-A95-0001)
3. Anon.: BMS Operations Manual, April 1971
4. Anon.: BMS Test Data Report, June 1971