

**SYMPOSIUM
ON
CLEAN ROOM TECHNOLOGY
IN SURGERY SUITES**

let P. 208

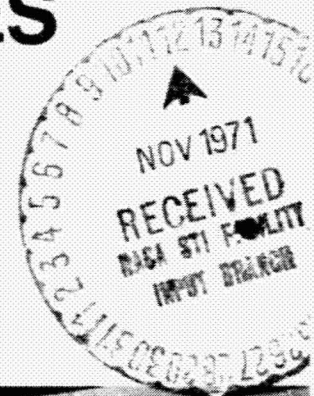

(NASA-CR-127442) CLEAN ROOM TECHNOLOGY IN
SURGERY SUITES (Midwest Research Inst.)
22 May 1971 218 p
CSCL 06E

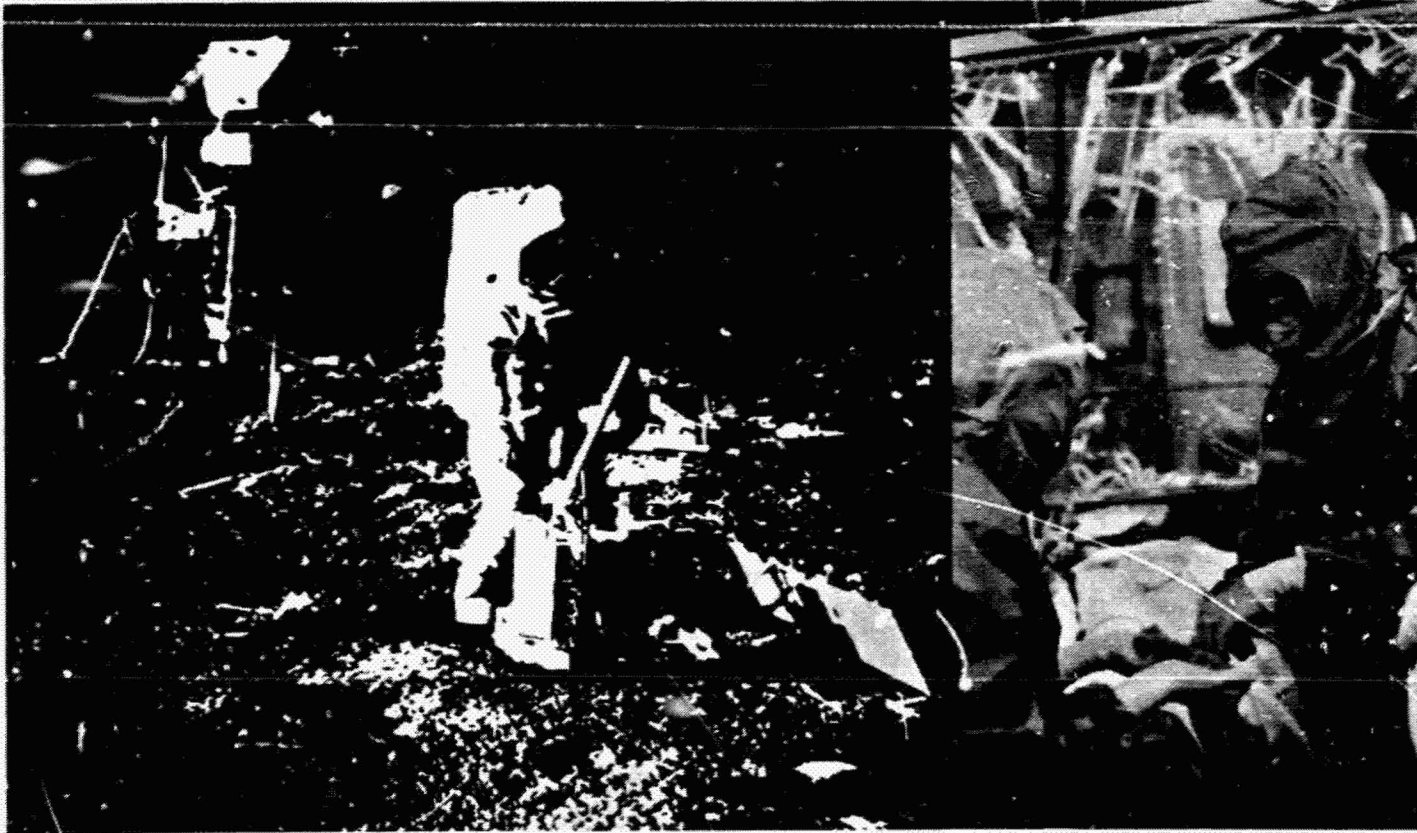

G3/04
Unclas
15677

N72-28034

OFFICE OF INDUSTRY AFFAIRS
AND TECHNOLOGY UTILIZATION



JOHN F. KENNEDY
SPACE CENTER

MIDWEST RESEARCH INSTITUTE 425 VOLKER BOULEVARD, KANSAS CITY, MISSOURI 64110

CLEAN ROOM TECHNOLOGY IN SURGERY SUITES

Proceedings of a Symposium Conducted
May 21 and 22, 1971

at

NATIONAL AERONAUTICS AND SPACE ADMINISTRATION
John F. Kennedy Space Center, Florida

Co-sponsored by

NATIONAL AERONAUTICS AND SPACE ADMINISTRATION
Office of Industry Affairs and Technology Utilization
Technology Utilization Office, Code KT
Washington, D.C. 20546

and

MIDWEST RESEARCH INSTITUTE
425 Volker Boulevard
Kansas City, Missouri 64110

Edited and Published by MRI under NASA Contract NASW-1936
(MRI Project 3332-E(D), Reprint MRI-1064)

PRECEDING PAGE BLANK NOT FILMED

PREFACE

This document presents the proceedings of the symposium on "Clean Room Technology in Surgery Suites" conducted on May 21 and 22, 1971, at John F. Kennedy Space Center in Florida.

The symposium was co-sponsored by NASA's Office of Industry Affairs and Technology Utilization, Washington, D.C., and Midwest Research Institute, Kansas City, Missouri.

The text consists of the presentations and comments recorded during the symposium. It was edited and published by Midwest Research Institute under NASA Contract NASW-1936. Needless to say, the apparent success of the symposium was due to the technical competence and fine presentations of all of the participants.

MRI wishes to acknowledge the support and hospitality of the Director and staff of John F. Kennedy Space Center for hosting the conference. Dr. Harter of NASA-KSC served well as banquet speaker and panel member. A special note of thanks is due to Mr. Jim Harrell, Technology Utilization Officer for Kennedy Space Center and his staff, Mr. Lee DuGoff and Mrs. Carol Ferguson, who made attendance at this meeting a fine experience for all.

Dr. Thomas Castles, Principal Pharmacologist and Director of the Biomedical Applications Team; and John E. Stacy, Jr., Assistant to the Vice President of Technical Operations and Manager of Technology Utilization, were the principal coordinators of the meeting for Midwest Research Institute.

MIDWEST RESEARCH INSTITUTE

Thomas Castles
Principal Pharmacologist

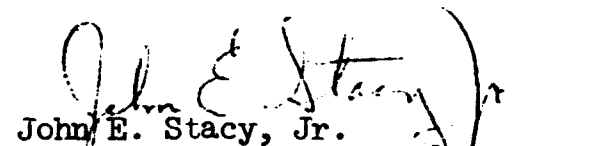
John E. Stacy, Jr.
Assistant to the Vice President

Approved:



F. V. Morriss
Vice President - Technical Operations

PRECEDING PAGE BLANK NOT FILMED

TABLE OF CONTENTS

	<u>Page</u>
Foreword	vii
Welcome to Conference - James T. Richards	1
Welcome to Kennedy Space Center - General D. F. Callahan, L.L.D.	3
<u>Session I</u>	
Introductory Remarks - H. D. Sivinski	7
Microbiology of Surgery Suites - John A. Ulrich, Ph.D.	11
Principles of Laminar Airflow Systems - Willis J. Whitfield, D.Sc.	33
<u>Session II</u>	
Use of Total Horizontal Laminar Flow Systems in Surgery - J. P. Nelson, M.D.	67
The Use of Total Vertical Laminar Systems in Surgery - Charles O. Bechtol, M.D.	81
Use of a Vertical Laminar Flow System Over the Operating Field - Richard E. Clark, M.D. and Kurt F. Bemberg, F.E.	93
Experience with a Wall-Less Horizontal Clean Air System During Total Hip Replacement - Carl L. Nelson, M.D.	107
Improving the Air Environment of the Operating Room - Harry Buchberg, Professor	117
<u>Session III</u>	
The Application of Laminar Airflow to Surgical Operating Rooms - John G. Whitcomb, M.D.	131
Asepsis and the Operating Room - H. C. Amstutz, M.D.	135
New Hips for Old; Total Prosthesis Replacement - Irwin S. Leinbach, M.D.	143

TABLE OF CONTENTS (Concluded)

	<u>Page</u>
<u>Session IV</u>	
Forum	165
<u>Participants and Attendees</u>	
Biographical Sketches of Participants	193
List of Attendees	207

FOREWORD

Clean room technology was born because of the need by the manufacturing community for quality assurance and reliability in complex equipment. The first breakthrough came in the middle 1950's when airborne dust was recognized as the common enemy in the manufacture of small, high-tolerance equipment. This led to the development of particle detectors and methods for maintaining dust-free environments; most notable of which was the use of the laminar flow principle by Dr. Willis Whitfield of Sandia Laboratories in December 1960. Clean room technology grew rapidly. The first laminar flow bench was installed for the Bulova Watch Company in April 1962. NASA's mission requirements for extraordinarily complex systems soon made it the leader in the development of clean room technology. By 1964, the medical community recognized the potential of clean rooms in medicine and the first microbiological tests of laminar flow in hospital areas were performed by USPHS. By 1966, the first medical operating laminar flow suite was used at Bataan Memorial Hospital in Albuquerque under the direction of Dr. John G. Whitcomb. Since this time more than 100 clean room operating suites have been installed in U.S. hospitals.

Last year, the MRI Biomedical Applications Team assisted a surgeon in locating NASA documents which he used to design and construct his own "clean operating suite." During this activity MRI became aware that there were several different types of "clean room" surgery suites and that laminar flow per se was apparently not the only answer. These observations led to the idea of having a conference on the application of clean room technology to surgery suites, primarily to examine the different types of "clean room" surgeries, to explore the total application of clean room technology, and provide open discussion on the problems associated with the use of clean room technology in surgery.

The conference achieved its goals in a realistic manner. Basic types of surgical clean rooms were presented, along with their advantages and disadvantages. Clean room technology was considered in its proper perspective, as an adjunct to good surgical procedure and not as a panacea. The principles of clean room technology were presented, as well as the criteria for their application to surgery. The inherent problems of comparing different types of clean rooms were discussed and several critical areas uncovered which lack the scientific information for valid conclusions.

This conference is the first step in an effort by Midwest Research Institute to mount an all-out effort to develop objective information on the application of clean room technology to medicine. We will use the research expertise of our institute to work with several of the symposium's participants toward our goal.

WELCOME TO CONFERENCE

James T. Richards
Chief, Technology Applications Branch
Office of Industry Affairs and Technology Utilization
NASA Headquarters
Washington, D.C.

Mr. Richards:

Good morning.

I would like to welcome you on behalf of NASA's Technology Utilization Program, and I sincerely hope that in the next day and a half here, you will have a very enjoyable and profitable stay with us. I would like to take this opportunity to thank the many people who have helped to plan and organize this symposium.

Particularly, I would like to extend our thanks to our Biomedical Applications Team at Midwest Research Institute. Most of you have probably met Jack Stacy and Dr. Tom Castles. In case you have not, Tom, I would like for you to stand up. This is Dr. Castles, who heads our Biomedical Applications effort there.

Also, I would like to thank our Technology Utilization people here at Kennedy, who have certainly helped tremendously in planning this operation. Standing in the back are Mr. Lee DuGoff and Mr. Jim Harrell, who is our Technology Utilization Officer. They will be making some announcements concerning logistics during the course of the symposium.

I would also like to thank Jack Sivinski from Sandia Laboratories, who is the manager of the Planetary Quarantine Department there. Jack has kindly volunteered to moderate our sessions. Jack, would you stand up so the folks can see you.

I now turn you over to General Callahan, who is Deputy Director of Administration here at Kennedy, so that he can give you an official welcome to Kennedy Space Center.

WELCOME TO KENNEDY SPACE CENTER

General D. F. Callahan, L.L.D.
Deputy Director of Administration
John F. Kennedy Space Center
Florida

General Callahan:

Good morning.

Ladies and gentlemen, it is my pleasure on behalf of Dr. Debus, the Center Director, and all of us here at the Center, representing NASA and your contacts with this organization, to welcome you to the Center and to let you know of our keen interest in working with you in making any utilization that is appropriate or useful of the technology which has been developed by NASA. We have keen interest in this clean room technology and the applications that you are taking a look at here today and tomorrow. I am sure that you are going to find something useful in these areas.

We endeavor to extend this kind of activity through our Technology Utilization program in whatever areas we can in order to transfer this information. For instance, within the past year we had a group of city managers from across the country in here taking a look at applications which might be of value to their purposes in running the cities of our country.

We are particularly happy to have you with us. I know that you will find Jim Harrell and Lee DuGoff and, of course, Dr. Allen Harter of our staff here, ready to explore and develop any aspects of our business which might be of use to you.

In these days when we see actions taken such as killing the supersonic transport, i.e., the funding and support behind it, it gives us real pause in NASA and real concern about what is going to happen as far as the continued growth and advance in technology in our country. We, and certainly management throughout NASA, are extremely aware of the need to bring home to the American people the applications that we have been able to make, or to participate with such gentlemen and ladies as you in making, and thereby bringing, benefits to our people from this program.

I would just leave this one other thought, my own observation of this kind of business. I ran a plant before I came to NASA 3 years ago where we had people who were making applications in this Technology Utilization area. They had to do with process control and that kind of thing, to run chemical plants, or watershed control systems for the Corps of Engineers. They were applications of technology in the data logging and supervisory control area, and, of course, computer applications were involved. The thing that hit me about all this was that we had people who had backgrounds they had developed in working with NASA and on NASA projects. They were able then to apply that background to these problems. To me, the exposure of our people, our scientists and our engineers, to advancing technology and to living in an environment where these advances had to be compressed timewise has been singularly important. There was real pressure to move ahead rapidly under

a project which was considered, if anything, the Number One project in our country in the last decade. It was to get a man on the moon and back. These people, through this exposure, have acquired a way of thinking that should be a tremendous asset, and I know is a tremendous asset, to our country. I would just like to leave you with the thought that what has been done to the minds of the people that have been involved in the program, and to the minds of the people that have become associated with or in contact with the program, represents the greatest spin-off of benefits to our country. I leave you with that thought.

We are delighted to have you here; we hope you will come back again, and I will look forward to seeing you on some other occasion. Unfortunately, I am not going to be able to be with you this evening because we lost one of our associates here a couple of days ago and I am going to be involved in that kind of activity. I would lots rather be with you.

Thank you very much.

SESSION 1

PRECEDING PAGE BLANK NOT FILMED

INTRODUCTORY REMARKS

H. D. Sivinski
Manager of Planetary Quarantine Department
Sandia Laboratories
Albuquerque, New Mexico

Mr. Sivinski:

Thank you very much, General Callahan, for an inspiring introduction to what hopefully will be a very profitable and worthwhile day-and-a-half session.

In my opening remarks to you I would like to review some things so that hopefully we can get some general consensus as to the purpose of this symposium. Based on my conversations with people I will mention what many of them feel we are trying to accomplish here today.

The first thing we want to do is review the basics of clean room technology because some of you here today are new to the field. This review will permit us to use the same language and will start us all from the same technological base line. Based on my past experience, communications will be our major difficulty these next 2 days, especially so since we have an interdisciplinary group in attendance. The same words will certainly mean different things to different people. The review of basics will hopefully minimize this problem.

After the review we will try to determine the state of the art in clean room technology. We will then examine the current needs and the problems associated with the hospital surgery-suite environment. The people discussing their problems in this area will run head-on into the communication problem, but given an effort on everyone's part we will more truly appreciate what his real problems are.

The next thing we will try to establish is the areas where reliable data exist and from these data, establish guidelines for obtaining the environment desired. These words are carefully chosen, because very seldom is the same environment necessarily desired in different situations because so frequently each man's problem is different. For those of you new to the field you will find in these 2 days that there is no given design that is a panacea for all problems. You will find there are even conflicting opinions as to what the problem is, as well as conflicting data for the environment observed. You will also find that this happens because we all are not even seeing the same things, given that we are observing the same phenomenon, simply because we are not all interested in the same things as we observe the phenomenon. Looking at the same environment we frequently are not even observing the same phenomenon because our requirements are different. So you can see that people having views other than you own are not necessarily wrong and therefore you must keep an open mind these next few days in order to profit most from your investment of time.

I think the fact that clean room technology is a useful thing cannot be argued. From the contamination control point of view it is used extensively to increase reliability (it makes the color television tube possible), and it is also used extensively in the pharmaceutical industries. Boards of Directors of companies are not spending their money foolishly when they authorize clean rooms for such areas because from a business point of view they can, in this way, maximize the return to the stockholder. But what we will try to do in the next day and a half is to determine the need and the utility for such rooms in the hospital surgical area.

We will hold speakers to their allotted time and those finishing early may answer questions. But the main time for questions and discussion will be at the forum tomorrow. We will process your question cards tonight as best we can to give continuity and purpose to the forum tomorrow.

Our first speaker this morning is an old friend to a lot of people. Dr. John Ulrich got his Ph.D. in Bacteriology from Minnesota in 1947. In 1949, he became affiliated with the graduate school at Mayo, where he stayed until 1969, plus a lot of other consulting jobs in between. As you can see, he was with Mayo for 20 years. When he decided to come to a place where the winters are not quite so severe as they sometimes happen to be in Minneapolis, he came to the University of New Mexico. He has a joint appointment at the University of New Mexico Medical School, in the Department of Pathology and the Department of Microbiology, and it keeps John pretty busy. The title of his talk is the "Microbiology of Surgery Suites."

Dr. John Ulrich.

PRECEDING PAGE BLANK NOT FILMED

MICROBIOLOGY OF SURGERY SUITES

**John A. Ulrich, Ph.D.
Chief, Microbiology Section
Bernalillo County Medical Center
Albuquerque, New Mexico**

Dr. Ulrich:

Thank you, Jack. Fellow members of the symposium:

The prime and continuing source of microbial aerial contamination in a surgery is the surgical team. Back in the era of the "golden scourge" in the late fifties when we experienced the pandemic of Staphylococcus phage type 80/81, it was fashionable to check people's noses bacteriologically, because we felt that this was the prime source of the organism. It is true that Staphylococcus aureus did reside and was found in the naris of many operating personnel. However, after carrying on a project for better than 2-1/2 years, sampling the personnel in surgeries at least once a week, and after better than 14,000 cultures, we had a correlation of only 13% between nasal carriers and infections originating in the surgeries.

It was obvious, then, that this was not really the major source of the organism that was causing our problem, so we sought elsewhere for the real source. The most obvious source was one of the largest organs in our body which is in constant contact with the environment: the skin. Thus, we began to study the skin to see if it was one of the problem sources of potential pathogens in surgery. Before we get into this area, I would like to review with you briefly the structure of the skin.

The human skin is a very involved structure, and the bacteriology of this organ is also very involved. It is more than just a contaminated surface, as many think it to be.

One of the techniques employed in surgery is to scrub assiduously to remove the bacterial population. But we only remove part of it, and the reason for this is that actually there are a number of populations on human skin.

First of all, there are microbial populations classified according to source. They can be divided into two different types, transient and indigenous. A transient population is one you pick up from contaminated external sources and then transfer elsewhere. As you shake hands with somebody, you pick up some of his microbial flora and give him some of yours. They are the part of the transient population that can be washed off rather readily and easily.

There is also an indigenous population, which we are concerned with in surgery because it is always with us. It is an important part of us, one of our main lines of defense against other invading organisms. Therefore, we do not want to destroy these bacteria; we only want to control them in surgeries and other sensitive areas.

On skin, we have a surface population that is also of an indigenous nature. Most of this population, however, does not grow readily on the surface of the skin. It comes from a deeper source. The majority of the indigenous population comes from the sebaceous glands and the ducts of the sebaceous glands.

To learn more about these populations we use a number of techniques to track down the dynamics of the bacterial population of the skin. The contact plate method is very simple, reproducible, and gives rather good data. It is nothing more than an aluminum milk-bottle cap that is filled with agar. The agar is placed in contact with the skin, immediately removed and incubated, and then quantitated after incubation.

Using this technique we can develop full-body patterns for the human being (Table I). Notice that the bacterial colony counts on the forehead, temple, eye, nose, upper lip, cheek, jaw, ear, chin, back of the neck and the neck are relatively high counts. Since these are total colony counts on a plate the size of a milk-bottle cap, it is indicated that the skin has a high density of the bacterial population in these areas. The axillary population is much higher in most people than indicated here. The use of underarm deodorants controls and reduces the population in this area. Normally without the use of deodorants the bacterial population is a little higher than around the head and the neck. The trunk and the outer arms have relatively low populations. The hand is high. This is due not only to the indigenous population but also the transient population. Generally, most of the lower parts of the trunk and the legs are relatively low in microbial population. These areas which are high include the groin, perineum, navel and buttocks. The inner thigh, the ankles and feet, although not listed, are found to be high population areas. In summary, each human being has essentially the same pattern of distribution with very high bacterial populations on the head and the neck, the axilla, the hands, the perineum, the groin, and the feet. The other areas are less heavily contaminated or populated. Note that one of the most highly populated sites is the angle of the jaw, and this is not covered during surgery.

Whereas each individual has essentially the same pattern of bacterial population on the skin, each of us is unique in the number of bacteria per square centimeter that we carry. Table II is a compilation of data gathered from a number of individuals, both males and females. Some have relatively high counts; some have relatively low counts. Whatever the level of the count, it remains relatively at the same level for long periods of time. It can be changed from time to time by special techniques which I will not discuss. The important aspect is that each individual has a unique and stable microbial level which can be shed into the air in surgery. Usually an individual that has a very high skin count is also a good shedder. Each of us constantly sheds into the air.

TABLE I
BACTERIAL SKIN POPULATIONS
 (Contact Plate Method: Right Side)

<u>Body Region</u>	<u>Site</u>	<u>Plate Count</u>
Head and neck	Forehead	348
	Temple	560
	Under eye	TNTC ^{a/}
	Nose	TNTC
	Upper lip	TNTC
	Cheek	584
	Angle of jaw	TNTC
	Behind ear	TNTC
	Under chin	TNTC
	Back of neck	211
	Neck	316
	Upper trunk and arms	Axilla
Upper arm--lateral		42
--volar		8
Elbow--lateral		8
--volar		24
Forearm--lateral		41
--volar		11
Wrist--lateral		TNTC
--volar		53
Hand--lateral		224
Palm		Pseudomonas
Lower trunk and arms		Shoulder
	Subclavicular	83
	Breast	50
	Lateral chest	15
	Lateral waist	15
	Groin	TNTC
	Perineum	TNTC
	Navel	TNTC
	Subscapular	128
	Buttock	TNTC
	Hip	104
	Lateral thigh	232
	Inner thigh	TNTC
Popliteal space	241	

^{a/} Too numerous to count.

TABLE II

BACTERIAL SKIN POPULATIONS IN DIFFERENT INDIVIDUALS
(Contact Plate Method)

	<u>1M</u>	<u>2M</u>	<u>7M</u>	<u>4F</u>	<u>5F</u>
Jaw	TNTCa/	TNTC	145	94	TNTC
Arm	2	26	109	13	b/
Breast	6	86	11	8b/	278
Abdomen	47	219	29	8b/	121
Groin	128	132	Cont.	74	113
Buttock	248	207	TNTC	106	52

a/ Too numerous to count.

b/ Spore formers.

We cannot scrape or wash these organisms away because of the subsurface replicating population. The technique by which deep or subsurface populations are studied is called tape stripping. A sticky sterile tape, made by the Minnesota Mining Company, called Tape No. 850, is used. Regular Scotch tape cannot be used as it contains antibacterial agents. The sterile tape is removed from the roll by the operator and pressed onto the skin, smoothed over with a sterile applicator, and removed, put into a Petri dish, agar poured over it, incubated and quantitated.

Each time one of these tapes is applied to the skin and pulled off, it removes a layer of cells and any bacteria that happen to be in that layer. Normally 20 layers of cells are removed serially in these studies. You cannot remove further layers, because minimal bleeding occurs. The type of data obtained using this technique is shown in Table III.

These are bacterial counts from the tape strips. Note again, the varying bacterial levels among subjects. Some people are relatively low-level carriers; some are relatively high, and some are intermediate in levels of populations they carry. After removing ten layers of cells, relatively large numbers of bacteria are still present in the skin. Thus, the bacteriology of the skin is not only a surface phenomenon, but much more complex. In between tape 10 and tape 11, a series of six 2-min surgical scrubs were performed and yet we continued to find demonstrable numbers of bacteria 20 cell layers down. These subsurface organisms cannot be controlled at the present time. These are the organisms that repopulate us, and we want to maintain.

TABLE III

DEEP BACTERIAL SKIN POPULATIONS
(Bacterial Colony Counts per Tape: Tape-Stripping Method)

<u>Tape</u>	<u>Subject and Sex</u>			
	<u>XII M</u>	<u>XIV M</u>	<u>XV F</u>	<u>XVI F</u>
1	72	157	167	35
2	36	145	182	36
3	31	167	260	88
4	51	115	201	46
5	23	160	215	41
6	20	42	132	27
7	29	39	86	10
8	29	56	101	42
9	23	58	61	43
10	43	55	57	37
11	4	24	5	10
12	1	20	3	7
13	5	12	5	11
14	14	8	6	13
15	3	8	8	6
16	8	6	7	12
17	8	10	5	8
18	5	3	7	6
19	6	10	5	7
20	5	6	5	15

The next technique is known as the Price technique and it is a modified surgical scrub. When Price first published this technique, he performed ten 2-min surgical scrubs. The amount of time to put on the detergent, to scrub, the method of scrubbing, and the amount of time to flush are checked by a stop watch. After the 2 min, the detergent is flushed from the skin into the measured amount of water and the bacteria are quantitated from the basic contents. Table IV is a compilation of the type of data gathered by this technique.

TABLE IV

REMOVAL OF BACTERIA FROM HANDS AND ARMS
(Mean Bacterial Count per Basin: Price Technique)

<u>Basin</u>	<u>Subject, Sex, and Number of Tests</u>			
	<u>XIII M</u> <u>(43)</u>	<u>XIV M</u> <u>(18)</u>	<u>XV F</u> <u>(25)</u>	<u>XVI F</u> <u>(29)</u>
1	40 ^{a/}	465	194	196
2	64	295	182	219
3	71	214	156	210
4	65	183	133	175
5	62	154	129	170
6	44	147	124	151

a/ Multiply by 10^5 for total count in basin.

Each one of these basins represents an individual surgical scrub. After the first 2-min scrub, subsequent scrubs are done consecutively, one right after the other. These particular data were gathered while using castile soap without a germicide. The observation that is important and interesting in these particular data is that skin bacteria cannot be completely removed even through six serial scrubs. One of the reasons is the deep population. The ducts and the glands act like little tubes of toothpaste, and as you scrub, massage and squeeze, bacteria are expressed onto the skin surface. Eventually, the surface population will be reduced to a minimal level, but it will continue at that level through subsequent scrubs. Apparently a triggering mechanism takes place as bacteria are expressed from the deeper sources, rapid reproduction commences. This indicates even with the use of germicidal soaps, this population cannot be destroyed. It remains in the deeper sites and the surface population is replaced in a short period of time.

Table V shows data on microbial shedding from humans and is more germane to the intent of this meeting. The reason that we went through the discussions on skin microbiology is to indicate what happens to these bacterial populations that are normally on skin. Some of them die off, but most of them are shed. These particular data were gathered by Mr. Riemensnider^{1/} at CDC in the microbiotank.

^{1/} Riemensnider, D. K., "Space Craft Sterilization Technology," NASA SP-108, 1966, pp. 97-103.

TABLE V

TOTAL VIABLE PARTICLES SHED BY INDIVIDUALS AT
VARIOUS EXPOSURE TIMES IN MICROBIOTANK

<u>Subject</u>	<u>Time in Tank (min)</u>	<u>Total Viable Particles Recovered per Minute</u>
A	10	62,000
	20	5,800
	40	46,000
B	15	6,500
	30	55,000
	30	3,300
C	15	47,000
	30	19,000
	30	28,000

The microbiotank, into which the subject is placed for varying periods of time, collects all of the particles that have been shed. These are quantitated for viable organisms. In the experiment shown in Table V, the subjects were naked. The numbers of recovered viable particles are listed with the elapsed time. From the prolonged studies performed by this group, it was found that the average individual with normal skin sheds on the average 10,000 viable particles every minute. This confirms the work of the English researchers.^{1-7/} With abnormal skin such as an eczematoid process or folliculitis, the shedding rate increases tremendously. The listed data pertain to people with normal skin.

- 1/ Duguid, J. P., and A. T. Wallace, "Air Infection With Dust Liberated From Clothing," Lancet, Vol. 2, No. 6535, November 27, 1948, p. 845.
- 2/ Bernard, H. R., R. Speers, Jr., and F. W. O'Grady, et al., "Modification of Operating Room Clothing and by Ultraviolet Irradiation," Lancet, Vol. 2, September 4, 1965, p. 458.
- 3/ Selwyn, S., and D. Chalmers, "Dispersal of Bacteria From Skin Lesions: A Hospital Hazard," Brit. J. Dermatol., Vol. 77, July 1965, p. 349.
- 4/ Speers, R., H. Bernard, F. O'Grady, and R. Shooter, "Increased Dispersal of Skin Bacteria Into the Air After Shower-Bath," Lancet, Vol. 1, No. 7383, February 27, 1965, p. 478.
- 5/ Bethune, D. W., R. Bowers, and M. Parker, "Dispersal of Staphylococcus aureus by Patients and Surgical Staff," Lancet, Vol. 1, No. 7383, February 27, 1965, p. 480.
- 6/ Hare, R., and G. C. A. Thomas, "The Transmission of Staphylococcus aureus," Brit. Med. J., Vol. 2, No. 4997, October 13, 1956, p. 840.
- 7/ Noble, W. C., and R. G. Davies, "Studies on the Disposal of Staphylococci," J. Clin. Pathol., Vol. 18, January 19, 1965, p. 16.

Fortunately, in surgery, barrier techniques are employed. Gowns, caps, gloves, and shoe covers are worn and these barriers reduce the amount of material shed into the air. The effectiveness of these barriers is shown in Table VI. These data were collected by Riemensnider. The subjects were wearing sterile dress--the gowns were autoclaved, and were completely sterile. Even though completely draped, the subjects shed demonstrable numbers of organisms. They were dressed in ordinary types of cotton gowns currently used in surgery. It is obvious that these gowns are imperfect barriers. Examination of these clothes with a magnifying glass shows large openings in them. It is like shooting a B-B through a tennis fence as far as bacteria getting through these materials. One aspect that helps is to wear a number of layers, which forms a somewhat better barrier. The barrier, however, is still quite imperfect, and even though gowned and draped, we are still shedding bacteria into the air, and these must be controlled in another way.

TABLE VI

CONSISTENCY OF MICROBIAL SHEDDING FROM INDIVIDUALS ON CONSECUTIVE DAYS
(Subjects Wearing Sterile Scrub Suit, Socks and Cap)

<u>Subject</u>	<u>Viable Particles Shed per Minute</u>		
	<u>Day 1</u>	<u>Day 2</u>	<u>Day 3</u>
D	3,660	3,030	3,500
E	2,170	2,130	1,870

Data collected by Mr. Dick K. Reimensnider.

Surface sampling of floors in surgical suites indicates the majority of bacteria recovered are human skin types. Gram-positive cocci and diptheroids are most common, but gram-negative bacteria are noted by their absence. Most of the bacteria on the floor arrive by the airborne route.

We should know more about the airborne bacteria in the surgery, and in Figure 1 are data gathered using samplers, which is a sliptype sampler. Two samplers were used simultaneously. This surgery did not have laminar air flow, but was an ordinary turbulent type of air delivery. Counts from the samplers followed one another fairly closely, even though they were placed in different sites in the room.

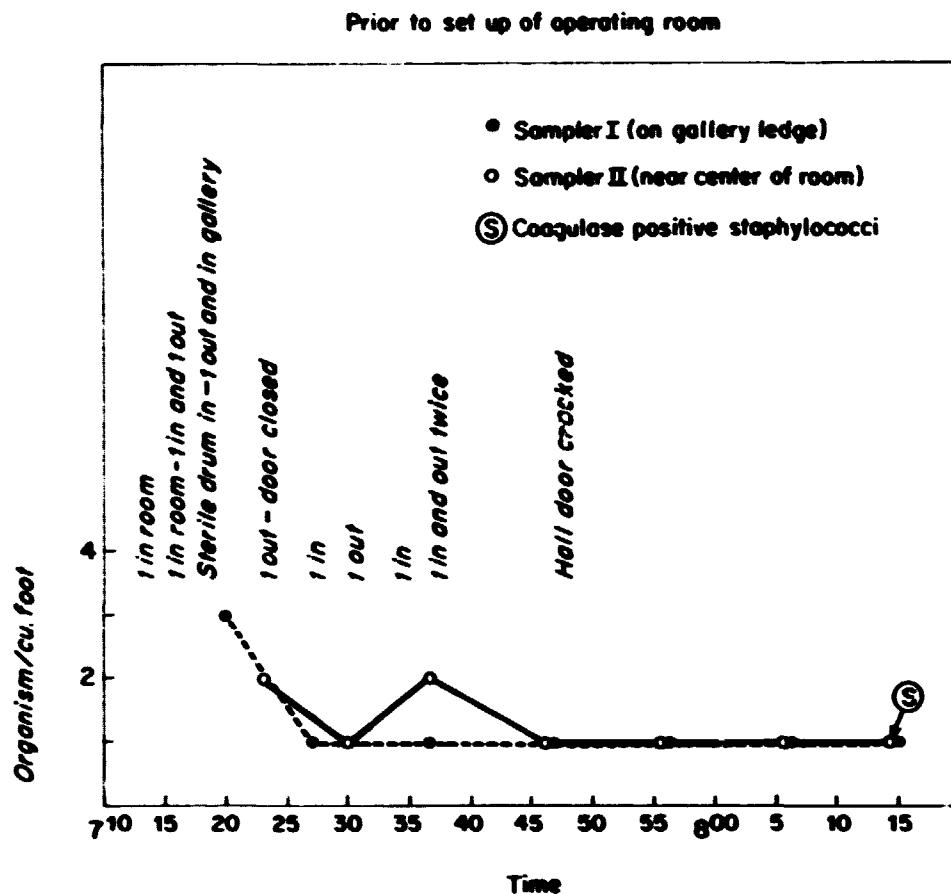

Figure 1 - Preoperative Microorganism Levels

Notice that the level of organisms in the air before the surgical team came in was about one organism per cubic foot. That is a low level with only the Casella operator in the room, and there were a few other personnel that were in and out. The symbol S means that a coagulase positive staphylococcus was isolated on that particular plate. Note again before the surgical team comes, there is a level of one organism per cubic foot in this particular surgery.

After the team arrives and begins work on the patient, the airborne bacterial count increases. The data in Figure 2 were gathered at a time when one surgical case was being finished and another started. There is an average of 10 surgical personnel moving about the surgery suite. The patient has undergone surgery and he is undraped at this point, and of course the activity in a surgery goes up tremendously at this time.

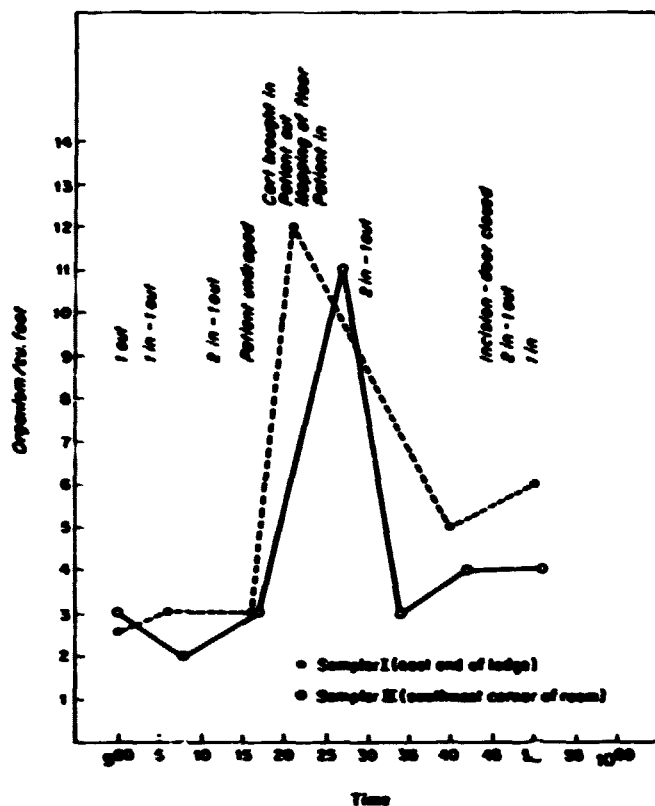

Figure 2 - Effect of Activity in Operating Room on Microorganism Levels

Nurses are moving around, picking up the dirty instruments; the patient is being undraped, picked off the table, put back onto the cart; the floor is mopped. There is an excellent correlation between the degree of activity and the airborne bacterial population. This is probably due to two causes: first of all, due to the activity, we are scuffing up more settled organisms from the floor; but probably more important, as our activity increases, our clothes rub and contact the skin. We break off more skin particles, and as a result, higher serial counts.

The legend indicates one patient is taken out and another brought in. When a patient is brought in, activity is very great, moving him to the table, scrubbing and getting him draped. New instruments are brought in, tables set up, there is a great deal of movement and so the airborne bacterial population stays high. But notice that as soon as personnel activity slows down, the number of organisms in the air drops rather dramatically and rapidly. The samplers, in spite of being in different parts of the room,

collect similar numbers of organisms in the same time periods. One of the important aspects which concerns us in maintaining low aerial counts is to reduce personnel activity as much as possible. Recall that once surgery is in progress, activity, outside of arm activity, goes way down. Again, we get to about one per cubic foot. Another factor that is very important is the number of people in the surgery. The data in Figure 3 point up the importance of the number of people. The more people present, the more airborne microorganisms released. These data were gathered during a very interesting case, which increases the number of spectators. Normally these surgical teams comprise about 10 people, but in this particular case there was approximately double that number. These observers were standing quietly. Notice the airborne bacterial levels. Instead of being around one per cubic foot, they averaged at least 10 times the expected number. It does not matter whether these people are sitting in a gallery or standing around the table, in an ordinary turbulence air system operating room. Bacteria, being the size that they are, follow the gas laws, and they diffuse much as gas does. Although you may have a point source, these organisms will fill the room in a relatively short period of time. The above is true in a conventional turbulent flow surgery, not in the laminar flow type that we will be discussing during the meeting.

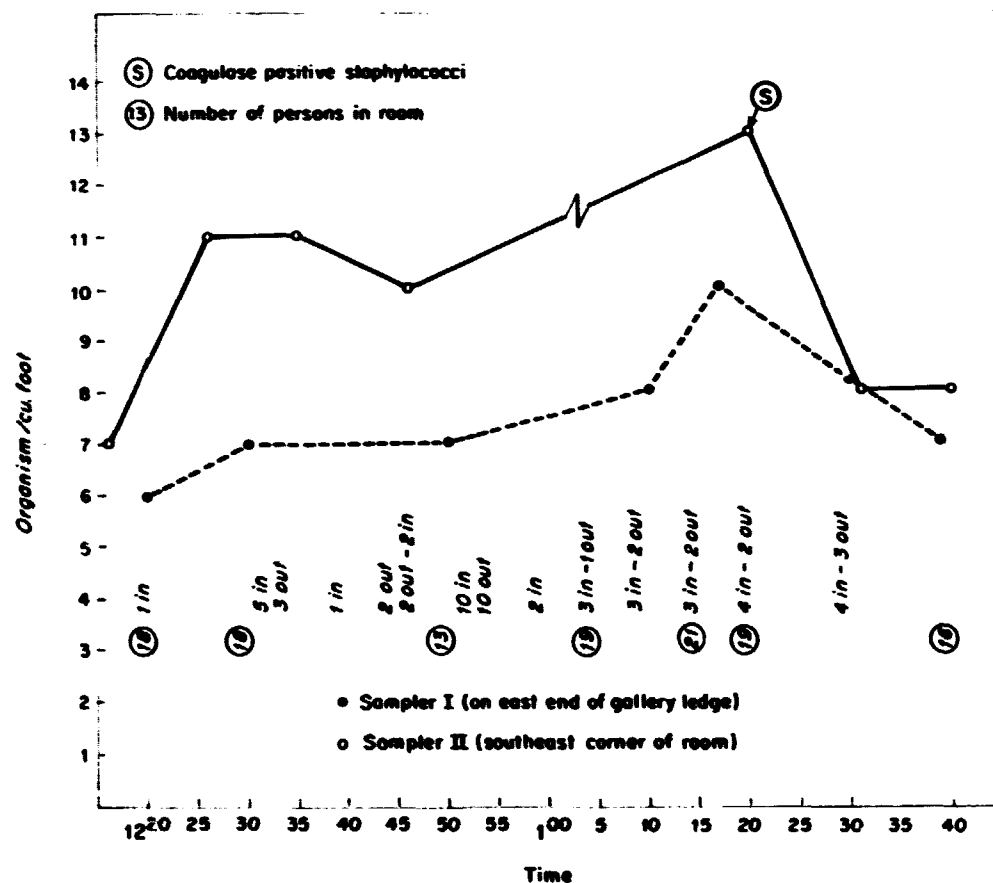

Figure 3 - Increased Activity and Personnel in Operating Room

The levels of airborne bacteria in surgeries are usually very low compared to what you will find right next to the surgery. Figure 4 shows what was obtained bacteriologically in the surgical hall next to the surgical suite. The data were gathered on a normal day. It is of interest that the number of people that traverse a certain point is much greater than expected. The levels in the hall compared to surgery, which is about one organism per cubic foot while surgery is going on, are averaging around 15 bacteria per cubic foot. Many coagulase-positive staphylococci are present in the hall air. Most of the organisms found in hall samples were human skin bacteria.

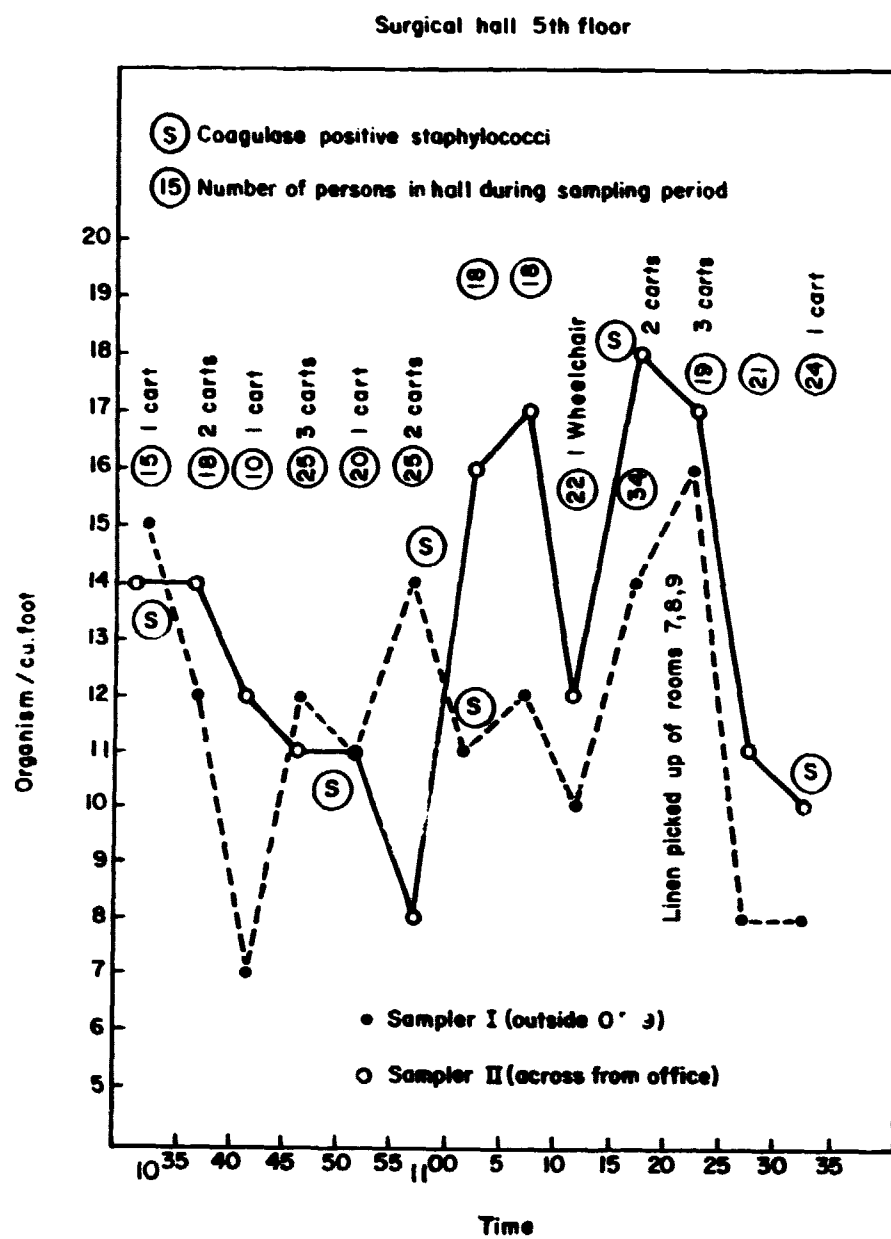

Figure 4 - Levels of Microorganisms in Surgical Hall

The data in Figure 5 indicate what happens when an infected patient is brought into surgery. This was a patient with severe staphylococcal infection. Within a minute and a half after arrival (the bandages were not yet removed), the samplers began to pick up the phage type of staphylococci found in his wound. He continued to shed these organisms all during the procedure in relatively large numbers. Interestingly enough, 2 min after the patient was removed from the surgery, we could not find the organisms in the surgery (walls, floor or air). It had been most likely swept out in the exhaust air.

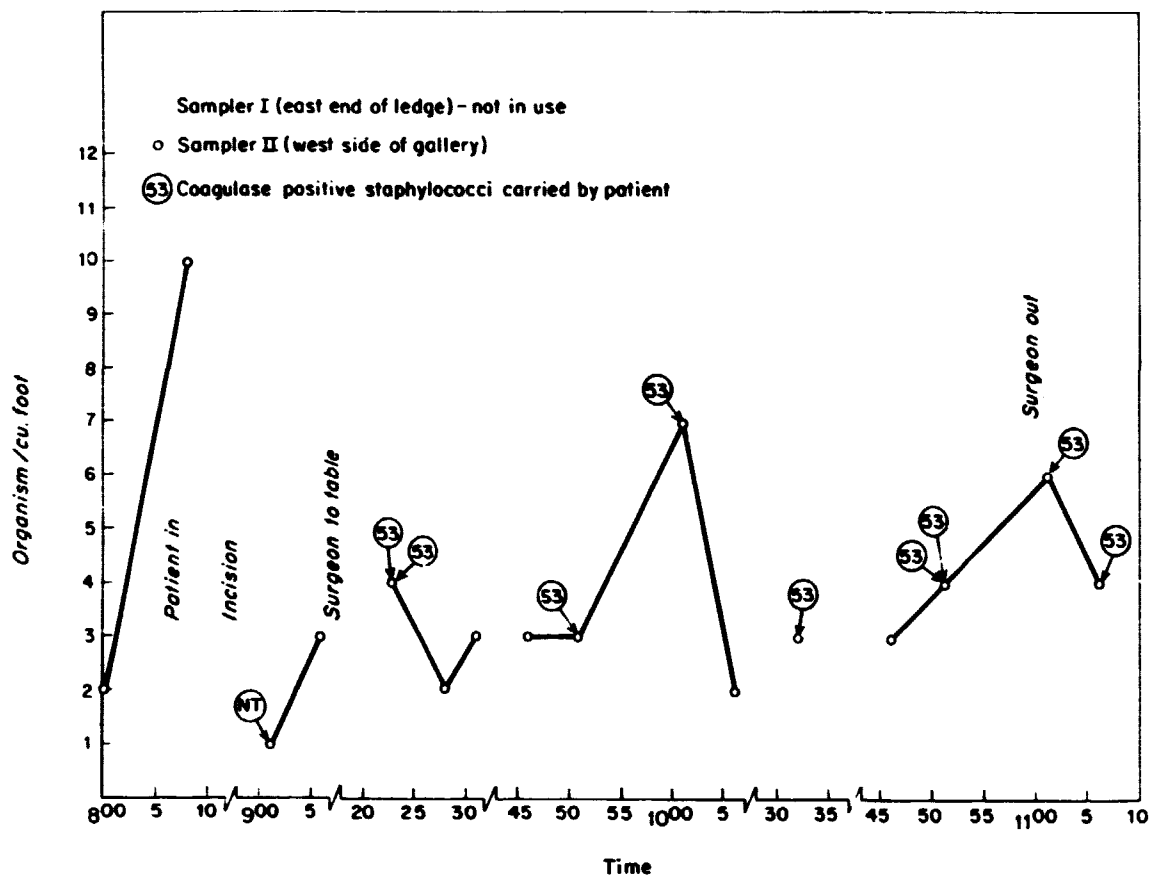

Figure 5 - Patient with Deep Abscess

The rapidity with which microorganisms can be disseminated is indicated in Figure 6. This was rather a peculiar and fortuitous type of situation in which the surgeon happened to cut into a deep abscess, of which he was not aware. One minute from the incision, the phage type of the organisms that was also isolated from the abscess was demonstrated on the sampler plates. Despite complete removal of the abscess, the organism was present in the air in the surgery as long as the patient was present. As soon as he was removed from the room, the staphylococcus disappeared also. The important aspects are the speed with which the organism disseminates and that it is present in numbers that can be sampled readily.

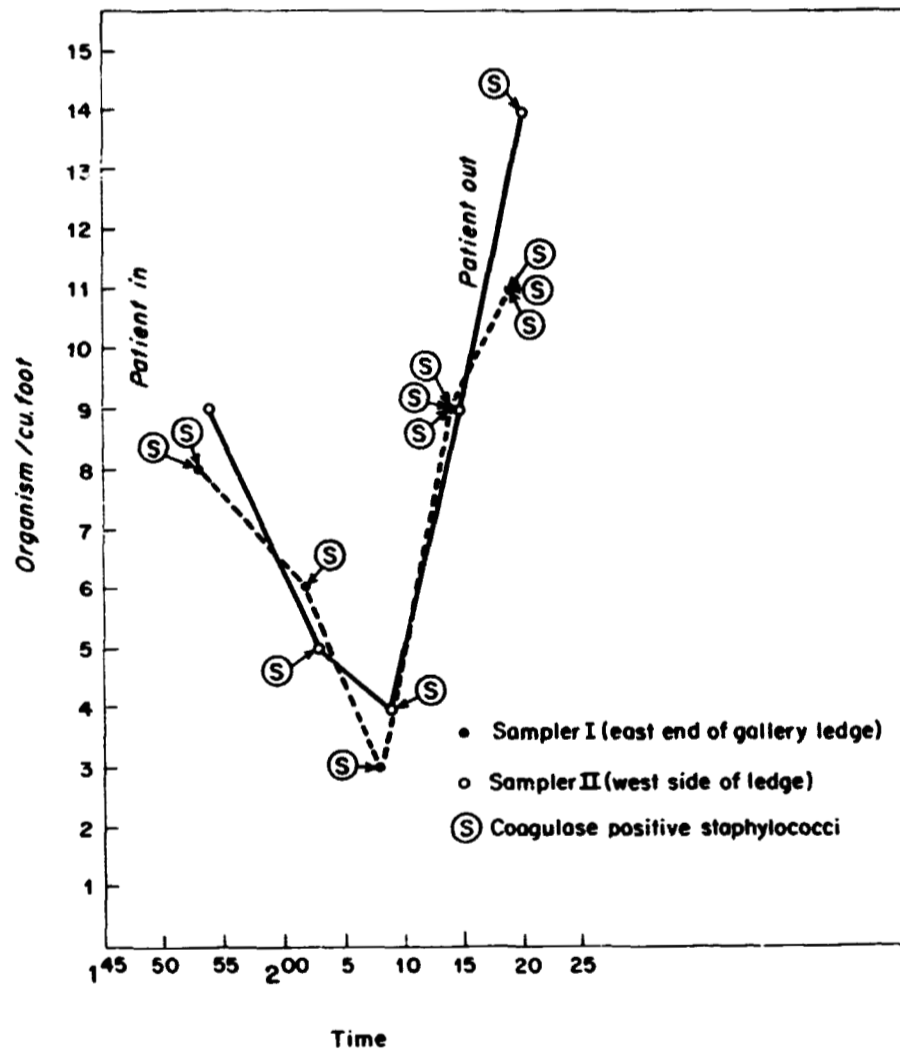

Figure 6 - Patient with Draining Wound

Table VII compiles data that relate surgical team personnel to infections originating in surgery. Twelve patients were infected by one surgeon in a period of 2 weeks with the same phage type staphylococcus. The surgeon had at the time subsurface boils that had not yet erupted, but he was shedding large numbers of organisms. His skin was checked using contact plates and in Table VIII it was noted he was colonized with the proper phage type of staphylococcus. Every site sampled during the third week was positive. At 5 weeks the jaw was negative, but the other sites were positive. At 6 weeks some sites became negative, and at 9 weeks the 80/81 staphylococci remained only in the area where the boils originated. During this period of time he received autogenous vaccine, because the staphylococci could not be controlled or removed with antibiotics.

TABLE VII

SURGICAL INFECTIONS RELATED TO A SHEDDER

Surgical Schedule					
<u>Thursday</u>	<u>Tuesday</u>	<u>Thursday</u>	<u>Friday</u>	<u>Saturday</u>	<u>Thursday</u>
Pt. 1, Sa ₁	Pt. 2, Sa	Pt. 3, Sa Pt. 4, Sa Pt. 5, Sa Pt. 6, Sa Pt. 7, Sa Pt. 8, Sa	Pt. 9, Sa	Pt. 10, Sa Pt. 11, Sa	Pt. 12, Sa ₂

TABLE VIII

COLONIZATION OF A STAPHYLOCOCCUS AUREUS SHEDDER

<u>Site</u>	<u>Duration Weeks</u>			
	<u>3</u>	<u>5</u>	<u>6</u>	<u>9</u>
Nose	80/81	52/52A/80/81	52/52A/80/81	47/53/54
Jaw	80/81	Negative	Negative	Negative
Arm	80/81	80/81	Negative	Negative
Shoulder (front)		80/81	Negative	
Lesion (rt. chest)		80/81	80/81	Negative
Back (midline)	80/81	80/81	Negative	
Waist				80/81

The fact that he carries these organisms on the skin is not of prime importance. The important aspect is the shedding of the pathogen into the air. We differentiate between carriers and shedders, and find that carriers, by and large, in surgery are not dangerous. It is only when they become a shedder that they become dangerous. The shedding studies shown for this individual in Table IX were performed 3 weeks following the outbreak. In doing a shedding study, the individual is placed in a small room with an air sampler, and the air is sampled for three different 10-min periods. First of all, he sits quietly, then he moves around the room rather moderately, and finally he moves about rapidly. Some nontypable staphylococci and some not related were isolated from the room before the subject was allowed to enter. When sitting very quietly, he was not shedding. When he started to move about, he began to shed, and we began to pick his organisms out of the air. The same tests were repeated at 6 weeks when his skin became negative except around the waist, and he was not shedding. He was allowed to go back into surgery with no further problems, even though he did continue to carry the 80/81 staphylococci on the skin in that area of the healed boils.

TABLE IX

SHEDDING STUDIES

<u>Activity</u>	<u>Total Count/ Cubic Feet</u>	<u>Phage Type</u>
Room only	6	47/53/83, no type
Sitting	13	No type
Moderate movement	41	80/81
Rapid movement	51	80/81 (2)
<u>6 Weeks</u>		
Room only	3	
Sitting	6	No type
Moderate movement	12	No type
Rapid movement	10	

In summary, the human being is the important source of airborne organisms in surgery. It is very rare that the mechanical equipment, the walls, or the instruments are sources, if they are cared for properly. Most of the airborne organisms in surgery are gram-positive.

What has been discussed here refers only to a surgery and not to other parts of the hospital such as on nursing stations where direct contact of individual to individual, nurse to patient, and then on to another patient, is probably the prime method by which organisms are spread. In a surgery, the use of barriers indicate the airborne route to be the most important.

Thank you.

Mr. Sivinski:
(Moderator)

Since the speaker has a few minutes left of his time--has not used it all--we will entertain questions for him at this time.

Dr. Tom Marks:
(Georgia Baptist Hospital, Atlanta, Georgia)

I would like to know what you think the optimum time would be for scrubbing and second if you have run any surveys between the cloth and the paper gowning in surgery.

Dr. Ulrich:

Yes, there are optimal times, but the optimal time depends upon the material that you are using and also the system that you are using. I do not want to get too deeply into this at the present time, but iodophores react very rapidly and they cause a very rapid reduction of bacterial population on the surface of the skin. They unfortunately, however, are very short-lived and our studies indicate that in 60 min plus or minus 15 min for each normal individual the effect has been destroyed--it is gone--and then you would have to do another scrub. But with the hexachlorophenes, the reverse takes place. Hexachlorophene is a very slowly reacting germicide, and it may take up to half an hour in many cases before it is most efficient. However, it has prolonged time in which it reacts. Its microbial inhibition increases for about the first 30 min, and then will hold level for approximately 3 hr in most people, after which it is lost. So you cannot set any particular time. You have to know what the agent is. You have to know also the technique that is being used and the skin of the individual itself. In fact, we have had individuals in the series which we were not able to reduce the

surface microbial population. These were people who had abnormal skins. One subject after a brutal half-hour surgical scrub still had as many bacteria on her skin at the end of the scrub as when first sampled. She would be a bad bet in a surgery. And to your next question--Yes, the cloth gown is probably superior to the ordinary cotton--I am talking about the old type linen. There are newer types of cloth now that are much closer woven, that do a far better job than the old type linen. Paper has a random pattern. Most of it is also plasticized today. The pore size here is much less than you will find in cloth, and as a result it holds better for a period of time. One thing you have to keep in mind, however, in all these things, is that it is only for a period of time, and this is true, also, of the masks that are worn. Surgeons during long procedures will have the same mask on for 6 or 7 hr. This is wrong. The mask should be changed about every 2-1/2 or 3 hr, because in that period of time bacteria penetrate the mask.

Dr. Leinbach:

(Private Practitioner of Orthopedics, St. Petersburg, Florida)

Have you done any work with the preoperative vaccination of patients with staphylococcus vaccine? Professor Weber of Saint Gallen in Switzerland claims that he has reduced his infection rates remarkably by this serial vaccination.

Dr. Ulrich:

No, we have not; however, the only way we were able to clean up the skins of surgeons that were like the one I showed you was with vaccines, autogenous vaccines. We have had good luck with these. We have not had any side reactions. The difficulties with these vaccines are side reactions. It appears that the ordinary vaccine, that is the commercial vaccine in this particular case, is not helpful. It has to be autogenous.

Mr. Jerry Post:

(Moore-Hanks Company, Los Angeles, California)

It is indicated by the counts that you had of a totally exposed body as compared to a gowned body that the primary source of contaminant at that time was from the exposed facial area as opposed to through the garments themselves?

Dr. Ulrich:

These studies were not set up to do this; the facial area was exposed. It seems quite likely that a good share of it does come from this area. The English have done some rather nice work in shedding. They feel that probably the greatest source comes from the perineum. They cover their surgeons with Vaseline and also put them in sort of a diaper plus the drapes. This effectively cuts down the number of airborne bacteria. I think they may have overplayed the importance of this area because the other sites may be just as important.

Mr. Sivinski:

The next speaker is probably known to most of you. Willis Whitfield received his degree in physics and mathematics from Hardin-Simmons University, did graduate work at George Washington University, University of New Mexico, and has his Doctorate of Science from Hardin-Simmons University. He came to Sandia Laboratories in 1954, and he has been associated with contamination control and many other things for quite some period of time. He is the Division Supervisor of the Applied Science Division of the Planetary Quarantine Department of Sandia Laboratories. For those of you that do not know, Dr. Whitfield was the one who was assigned the original patents in laminar flow technology. The first patent for the laminar flow clean room, and the one for the laminar flow clean bench are patents that belong to Willis Whitfield. So he started this whole thing. Because of it, he was awarded the Individual Scientific Technical Achievement Award by the American Association for Contamination Control in May of 1969, the Holley Medal by the American Society of Mechanical Engineers, which is rather hard to get, in November of 1969, and the Research Achievement Citation by the European Contamination Control Foundation in Stuttgart, Germany, in 1970. The title of Willis' paper is, "Principles of Laminar Air Flow Systems."

Dr. Whitfield.

PRECEDING PAGE BLANK NOT FILMED

PRINCIPLES OF LAMINAR AIRFLOW SYSTEMS

Willis J. Whitfield, D.Sc.
Sandia Laboratories
Albuquerque

Dr. Whitfield:

Thank you, Jack.

If we might have the house lights off, I would like to put on a simple demonstration after your eyes have become accustomed to the darkness.

Since the clean room is one of the main interest items of this seminar, we should consider what the clean room actually controls. Much has been said about the clean room, what it does and how much it will cost. However, it has one main function--that of controlling airborne particles.

One of the considerations about airborne particles is their tremendous number. They are almost infinite in number, shape, size and material, depending on the source and the manner in which these particles are formed. They vary from much less than $1\ \mu$ in size to hundreds or even thousands of microns in size. Immediately this gives you an idea of the tremendous range and complexity of the airborne particles that we are talking about. The origin of such particles is usually soil, dirt, plants, animals, people, mechanical devices, chemical reactions, etc. Almost every activity that we are concerned with generates particles. The main topic of this symposium is concerned with microorganisms, and certainly many of the airborne particles are microorganisms or have microorganisms attached to them. Obviously, some are dangerous to us and some are not.

Small or low density particles will usually remain airborne for extremely long periods of time. As a matter of fact, some of them settle at a rate of less than one thousandth of an inch per hour, depending on size and density, and may be carried and dispersed over considerable distances with time. This is one of the common means by which diseases are spread to man, plant life and animals.

Such particles are easily seen with the naked eye. I have a light source which I will turn on and aim over your heads. By now your eyes should be quite sensitive. I will show you some of the things that Dr. Ulrich was describing earlier. You can see the very large number of particles in the air, probably in the order of several millions. I think I can illustrate quite graphically how people shed particles and I will rub my hands together and you can see tremendous numbers of particles in the light beam. If I dust my clothing, and this suit came from the cleaners just before I started this trip, you can get an idea of another source of airborne particles.

The purpose of the clean room is to limit or control the kind of particles that you saw in the light beam. And it controls by two basic means: one, it is an enclosure that acts as a barrier which excludes many of the particles that are outside the clean room; and two, it filters particles

from the air before it enters the clean room. Additionally, in the case of laminar flow clean rooms, airborne particles are carried from the room by unidirectional airflow, as you will see as we go into the presentation.

Now, if we could have Slide 1 (Figure 1) you will see some examples of airborne particle sizes. I attempted to circle some of the common atmospheric dusts and their size ranges--you notice that it goes from about a hundredth of a micron all the way up to somewhere between 10 and 100 μ . It shows the size range of virus, the molecular particles, and bacteria. Such things as human hair, pollens, plant spores, and various other kinds of dirt are also shown on this slide.

As particle sizes decrease, the settling rate becomes very, very slow. Consequently, particles that are in the air, even some of the small particles you saw here with the light beam, will not settle out for many, many hours. If this room were closed and all air turned off, there would still be some of these particles gradually settling hours and even days later, depending on particle size and material.

Next slide please (Figure 2). This is a duplicate of the curves in Federal Standard 209a for Clean Rooms. We will refer to this later, but the thing that I would like to point out now is the fact that these curves indicate average particle size distributions that exist in the air. If we were to sample the air in this room, the curve might be much higher, but it would still be parallel to the distribution and size found in clean rooms.

Next slide please (Figure 3). I think this is a rather important slide, in that it shows the relative importance of airborne versus surface particles. In the case of this symposium, we might call the product the patient. The product would come into the clean room with its own load of contamination as the patient would come into the operating room, as Dr. Ulrich pointed out, with his own load of bacterial contamination.

As the product is brought into the room, it accumulates more contamination by five different means or paths. In the commercial clean room, we find that fallout or direct impingement is one of the least troublesome paths of airborne contamination to the product. The two most serious are: one, the contamination that falls on equipment in the clean room, such as tools, bench tops, and other equipment, is then carried directly to the product by contact; and two, the contamination generated by people in the clean room.

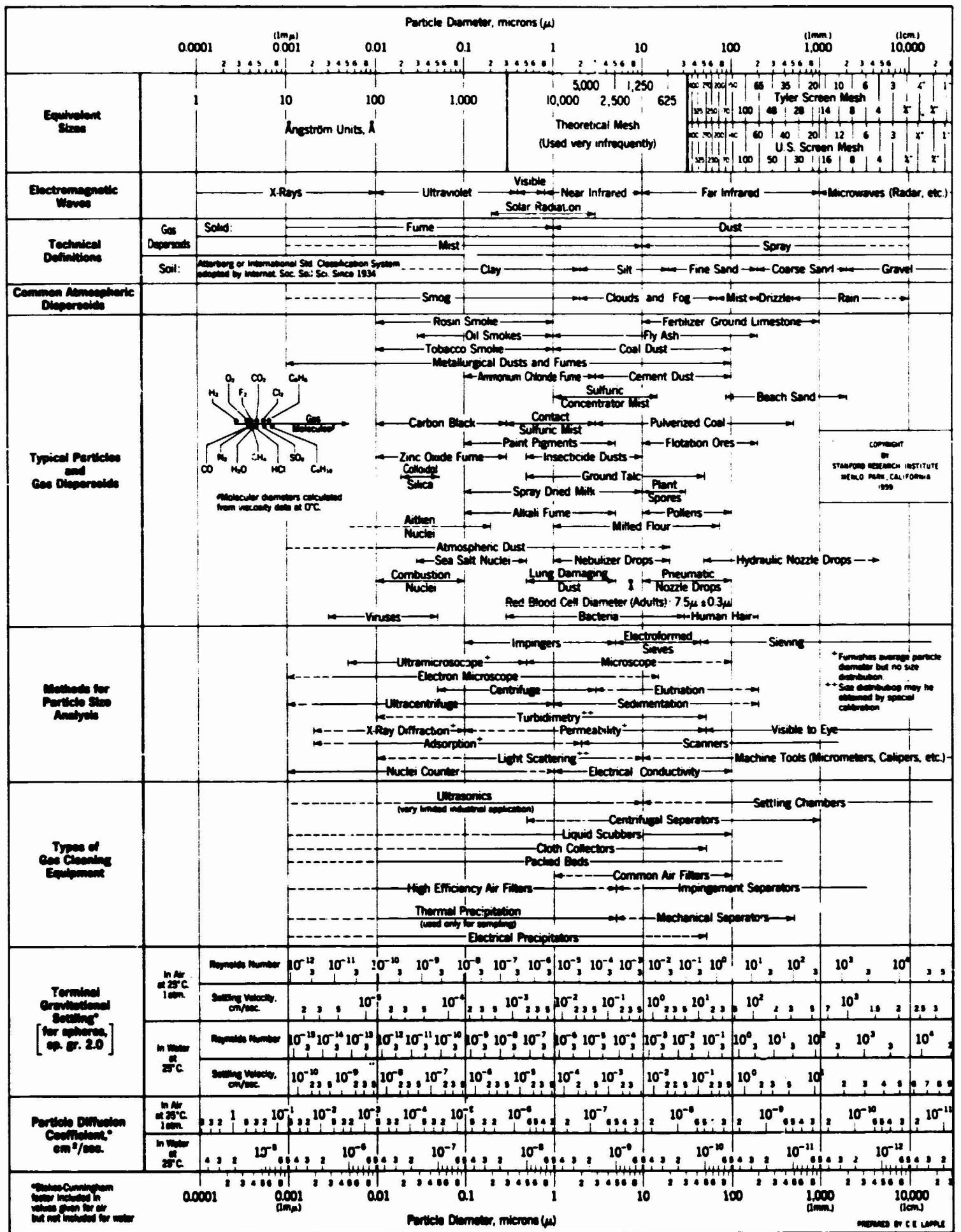
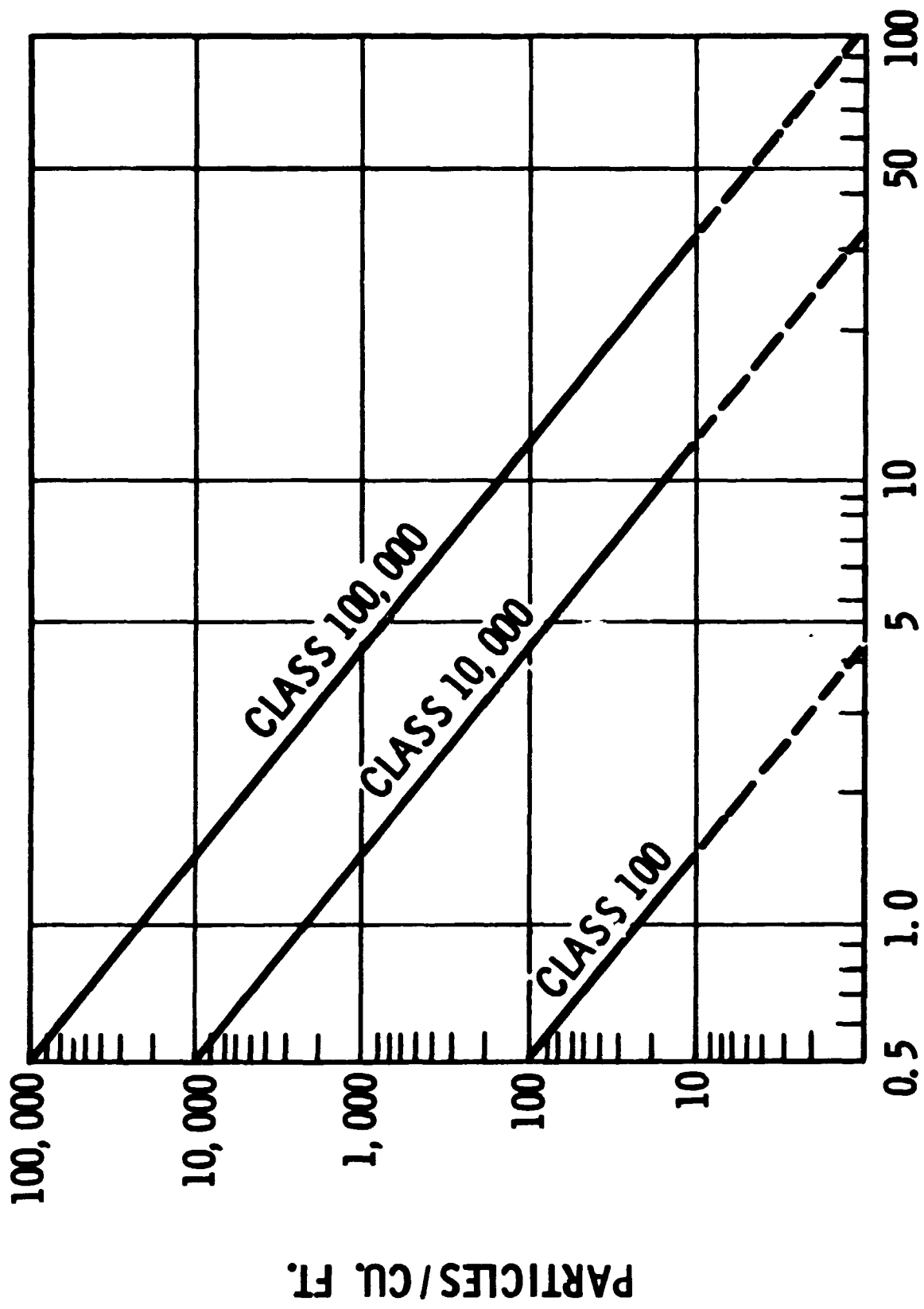

Figure 1 - Characteristics of Particles and Particle Dispersoids



PARTICLE SIZE - MICRONS

Figure 2 - Federal Standard 209a Clean Room Class Curves

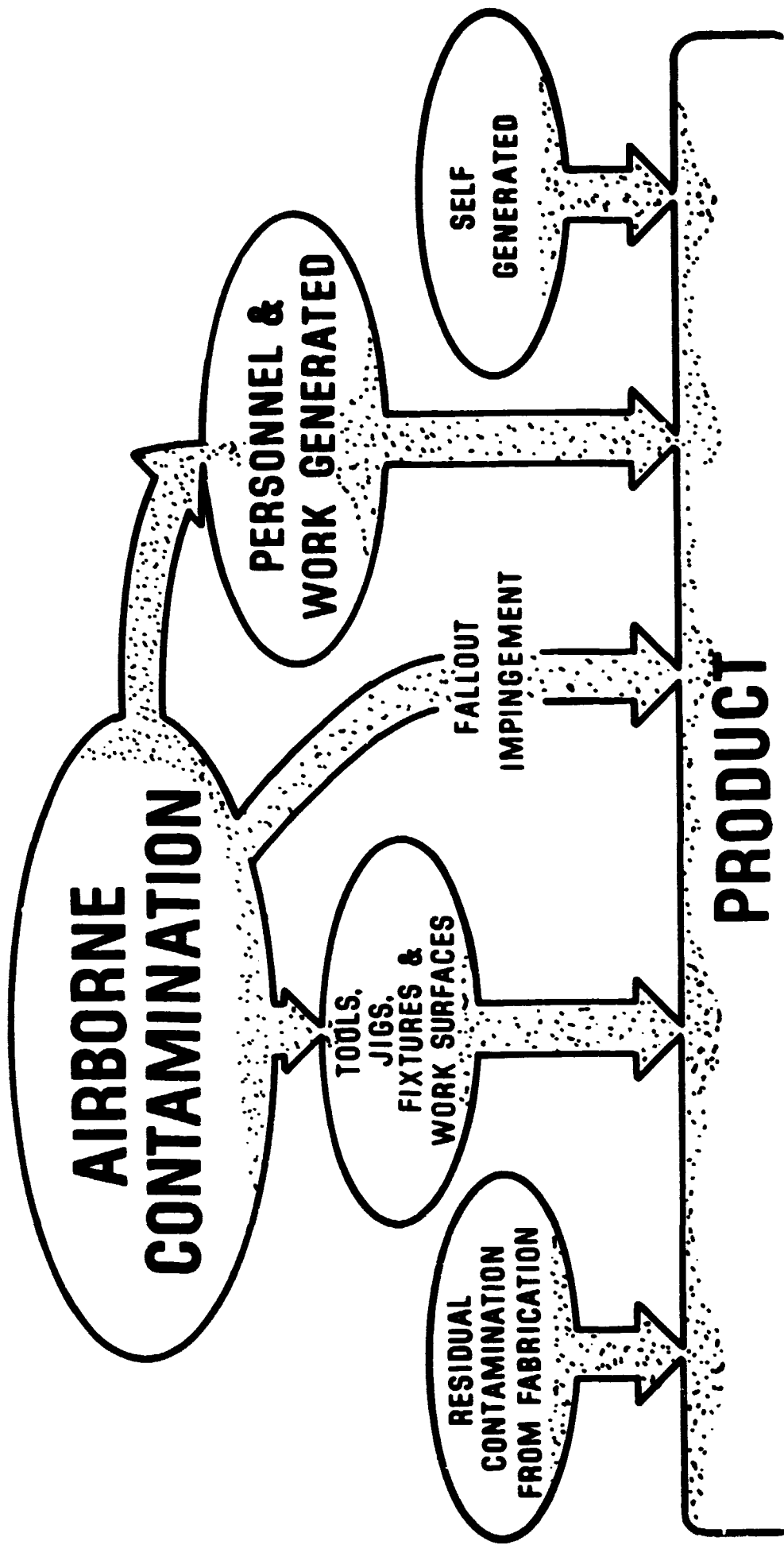

Figure 3 - Relative Importance of Airborne Versus Surface Particles

Next slide please (Figure 4). This is an artist's drawing of what might well be an operating room in your own hospital, or it might represent what we call a nonlaminar flow or a conventional clean room. The filtered air is brought in from the ceiling, allowed to mix in the room and is removed, hopefully, near the floor. It is intentionally a mixing chamber; thus airborne contamination in the clean room will be dispersed throughout the room.

Next slide please (Figure 5). This is just a very simplified drawing of a vertical laminar flow room. As you notice, the whole ceiling is an entry way for air coming into the room. The whole floor is an exit for the air leaving the room. Consequently, the air flowing through the room, without major disturbances, flows in straight lines, and is what we might call unidirectional airflow. Particles released in the room will be carried out very quickly with the air stream.

Next slide please (Figure 6). This is an illustration of what happens in a vertical flow clean room. As the worker standing in the middle of the room sheds contamination it is carried from the room through the floor and removed by the filters. The turbulences and the interferences caused by the person will be discussed later.

Next slide please (Figure 7). This is a cutaway drawing of a vertical laminar flow room showing the filters, lights, grating floor, a prefilter with a return-air plenum underneath, blowers, a subplenum to provide a very uniform airflow which is a necessary item in the design of a laminar flow clean room, and the HEPA filter plenum.

The nextslide (Figure 8) shows a picture of the development model at Sandia. This room is only about 10 ft wide by 20 ft long. So far as I know, it was the first vertical flow room. Notice the grating floor and the filter ceiling. The lights, however, are no longer in this position and are now positioned across the room. We have learned a lot from this room and a number of design changes have taken place since its fabrication. However, this room is a good performer and is still operating at better than Class 100.

Next slide please (Figure 9). This shows a cross section of another vertical flow system. It is what we call a curtain laminar flow system. It consists of a prefilter, blower, plenum and final filter system and has plastic drapes to direct the airflow downward and out under the curtain. The advantages of this are that it is portable, it can be easily moved, and it is less expensive than rigid wall facilities.

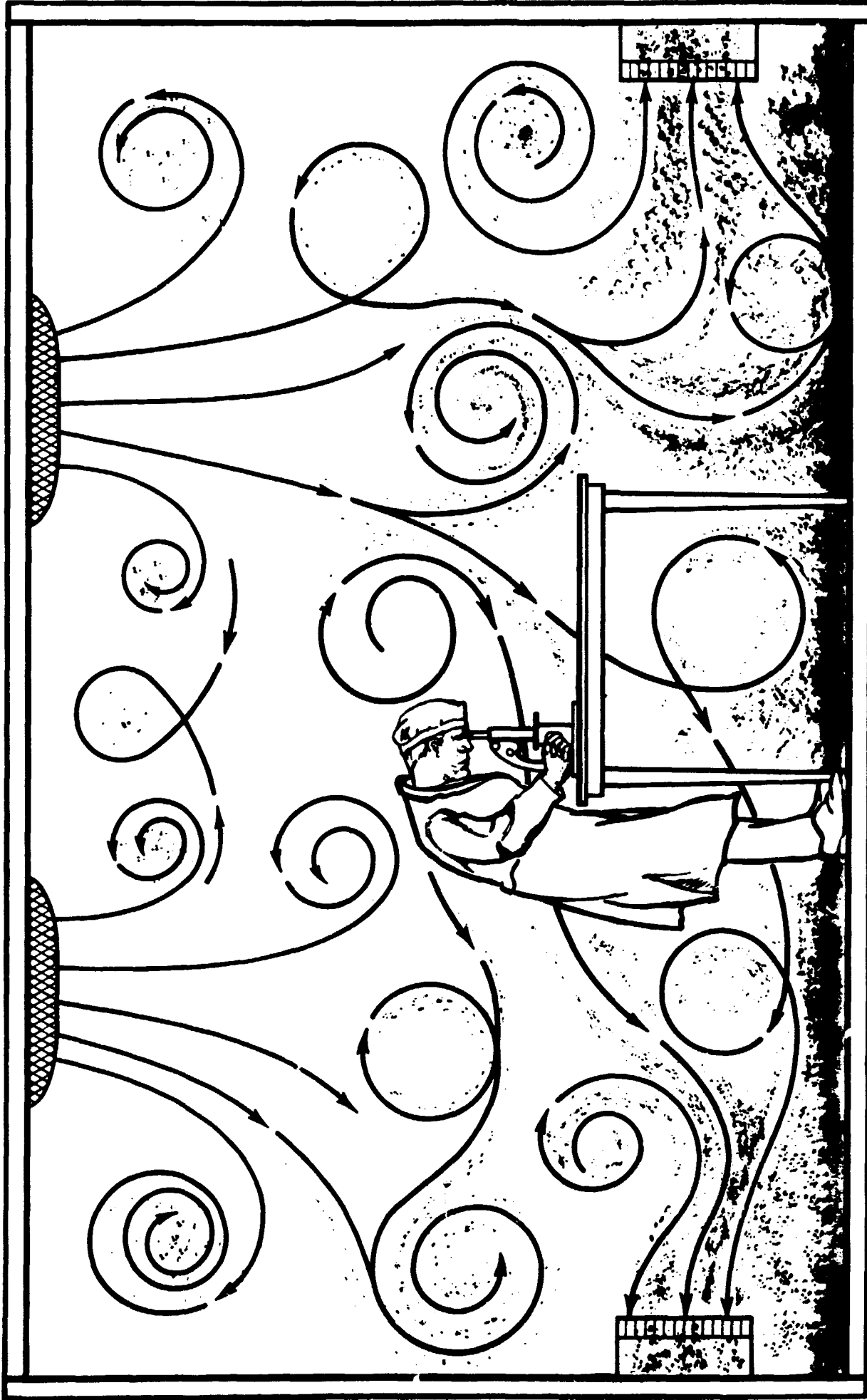

Figure 4 - Conventional Clean Room

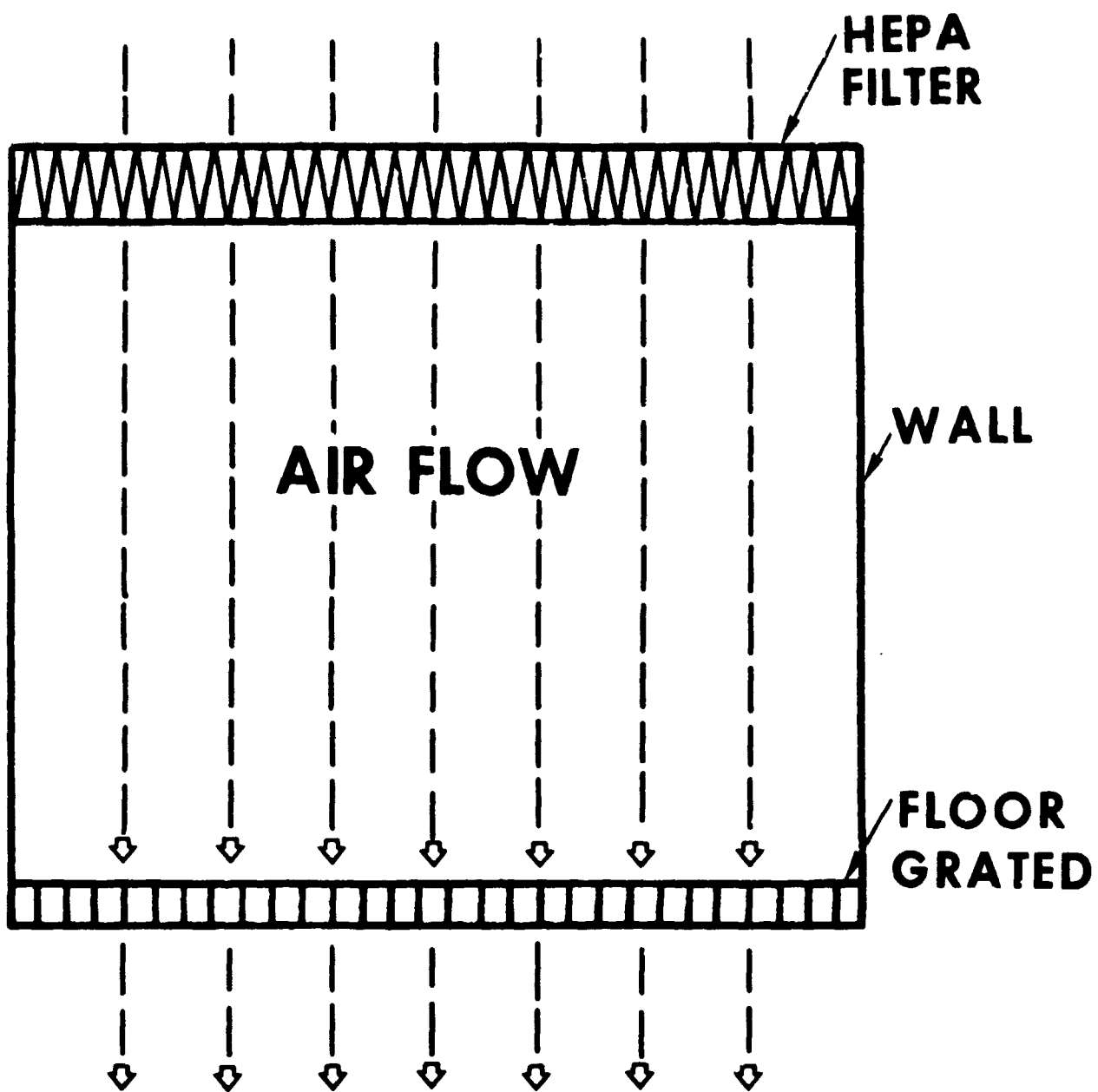

Figure 5 - Basic Laminar Airflow Concept

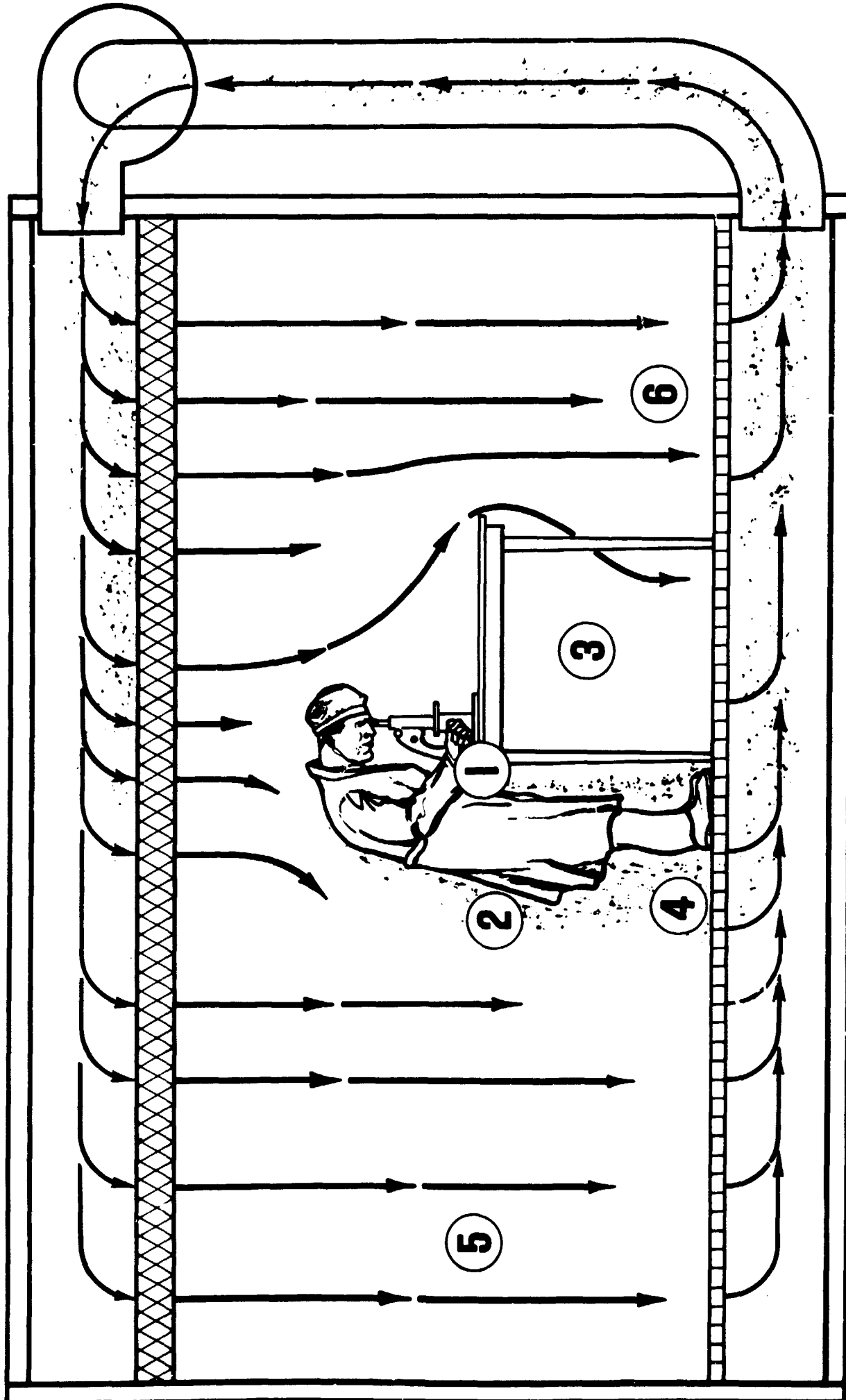

Figure 6 - Laminar Flow Clean Room

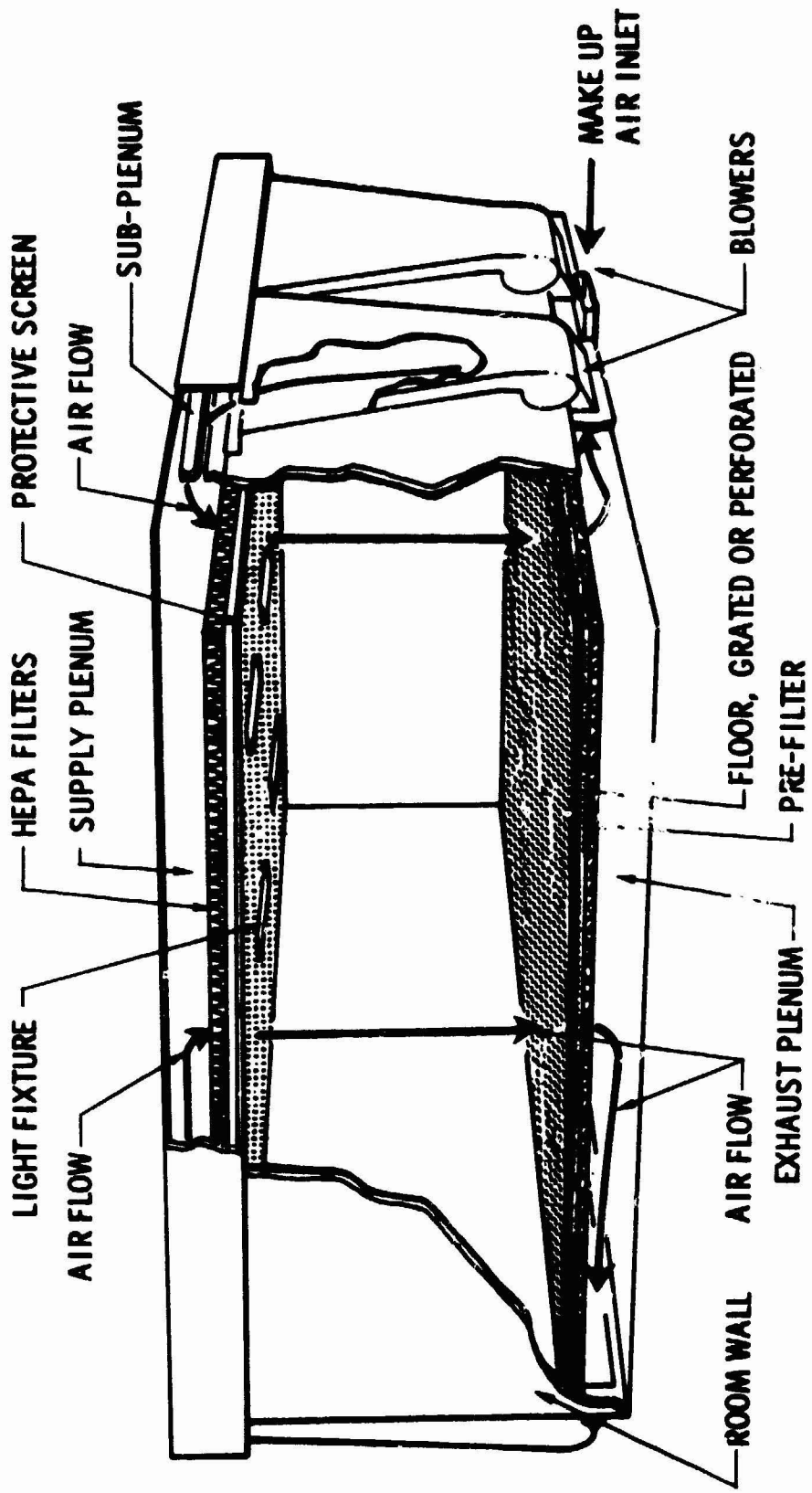

Figure 7 - Vertical Flow Clean Room

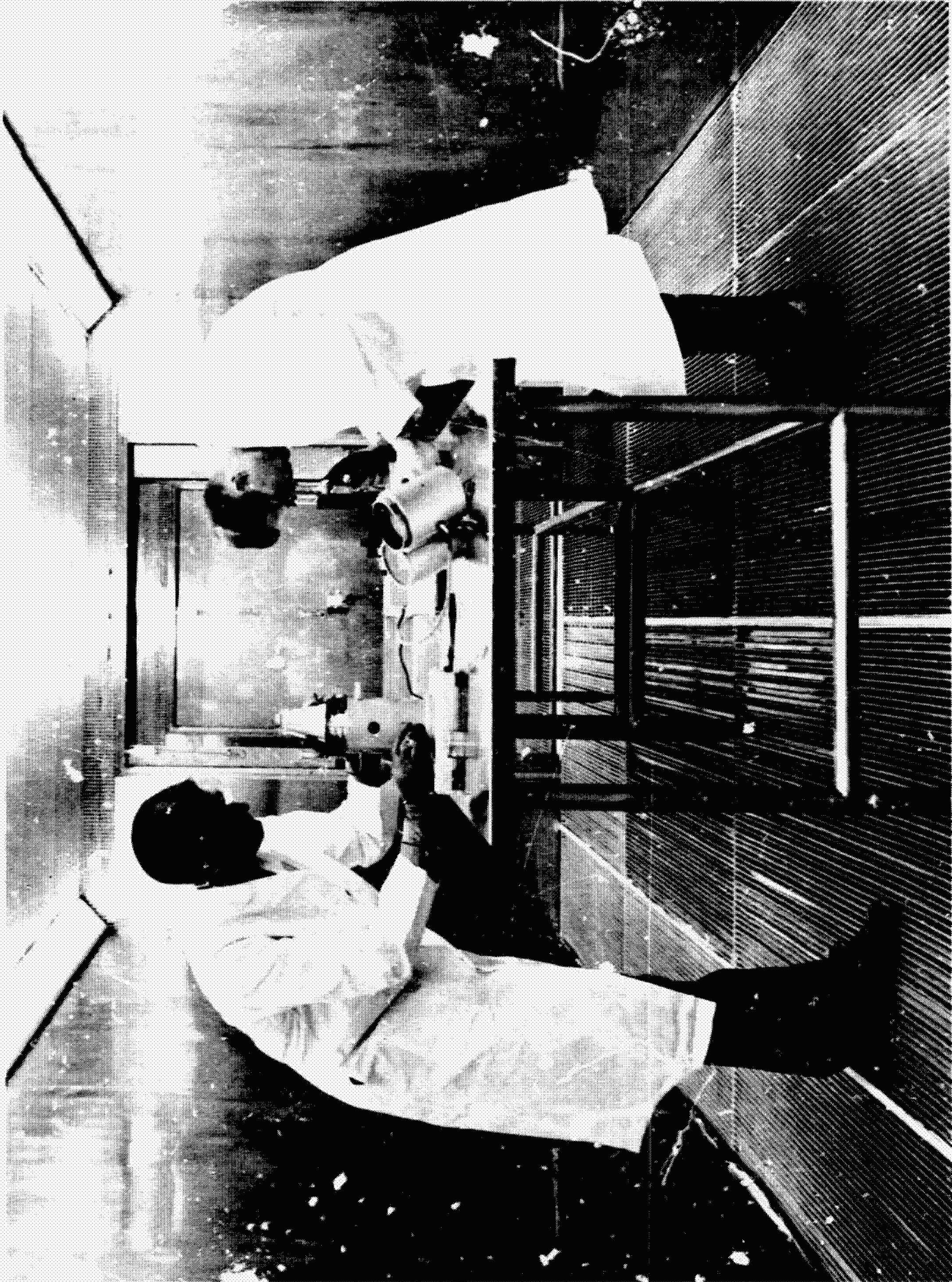

Figure 8 - Developmental Model of Laminar Flow Room at Sandia Laboratories

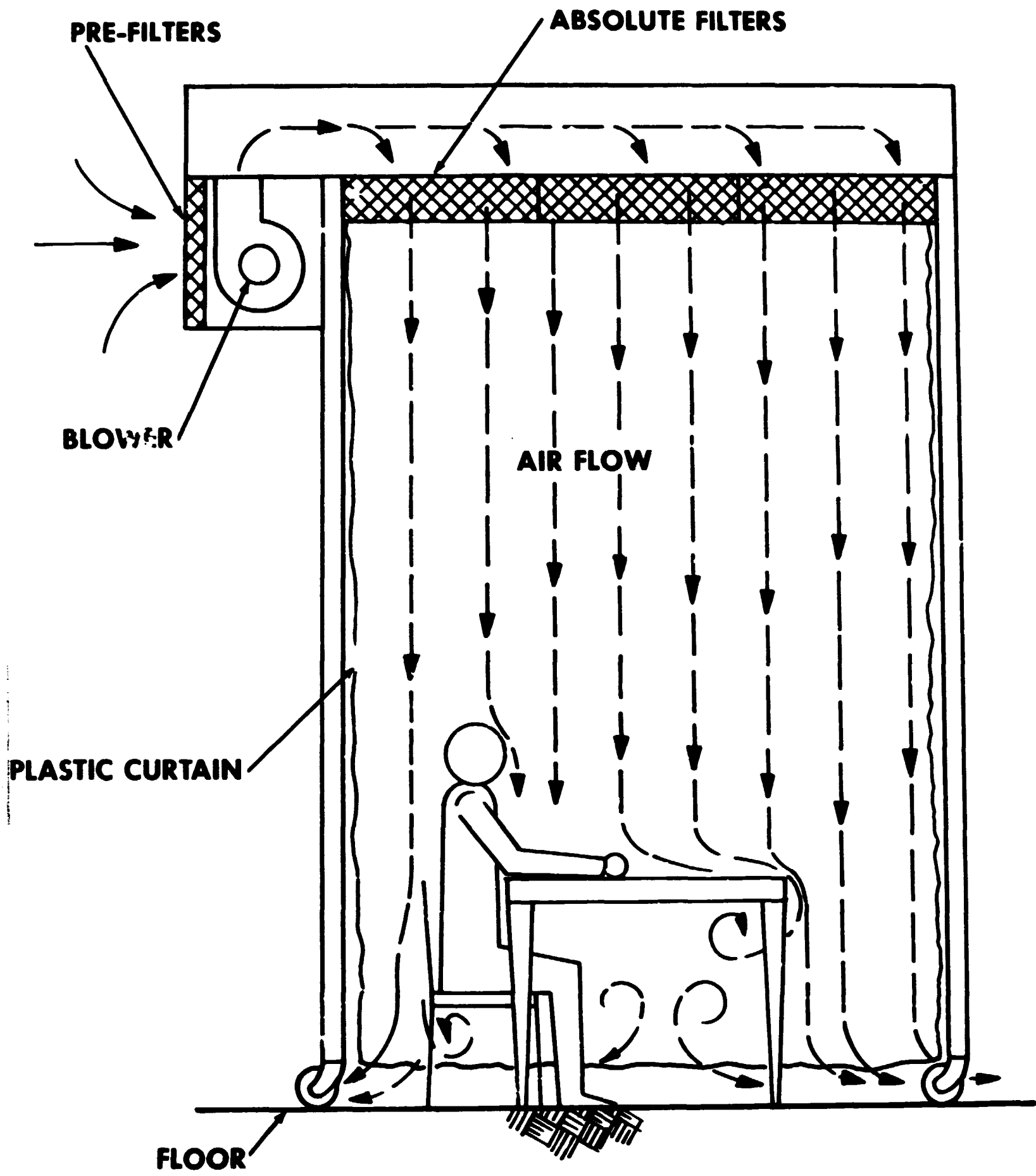

Figure 9 - Airflow Patterns of Unit with Work Bench and Worker

The next slide (Figure 10) will give better detail of the curtain unit, showing a cutaway view. The prefilter is very important in this particular unit because this unit may be located in a dirty area with more gross contamination than that to which other laminar airflow devices are normally exposed. Thus the prefilter ahead of the blower system or immediately after the blower system and before the final filters provides protection for the HEPA filters. Again you see the legs, casters, plastic curtain, etc.

Next slide please (Figure 11). This slide shows another developmental model of a curtain unit. As you can see, it is sitting outside a building. Used in this way, it cleans atmospheric air and provides clean room facilities completely exterior to a building.

The next slide (Figure 12) shows the first hospital operating room to use laminar flow. It is very similar to the curtain units we have just seen. It was installed in an existing operating suite at the Baatan Hospital in Albuquerque and has been in operation for 5 years. The filter bank is located immediately above the lights. As the air exhausts from underneath the curtain, it is refiltered and recirculated over the operating area. The operating room was quite small to begin with, and the addition of the laminar flow unit made it more congested. However, according to Dr. Whitcomb, who is Chief of Surgery at the Lovelace Clinic, the room has worked out quite well. As I remember, microbial count in this room dropped from approximately one to three per cubic foot to an average of less than a hundredth of a microorganism per cubic foot. Dr. Whitcomb found the worst condition in the room immediately underneath the operating room table where three-hundredths of a microorganism per cubic foot count was taken. Most of the counts were zero in open areas of the room. Counter probes were located near the incision points in a number of operations and the counts were very low. In many instances the counter ran for hours without a single count. The room was very difficult to evaluate statistically because of the extremely low count, but we must assume that the microbial count in this room is approaching zero.

Next slide please (Figure 13). Another basic derivation of the laminar flow system is the cross flow or horizontal laminar flow clean room. In this type room the filter bank forms one entire wall while the air exits through the entire opposite wall. It is basically the same device except that now the air flows across the room as opposed to flowing from ceiling to floor as it does in the down-flow room.

One thing I did not mention earlier. Air conditioning is usually added in the return air loop to condition the air for temperature and humidity.

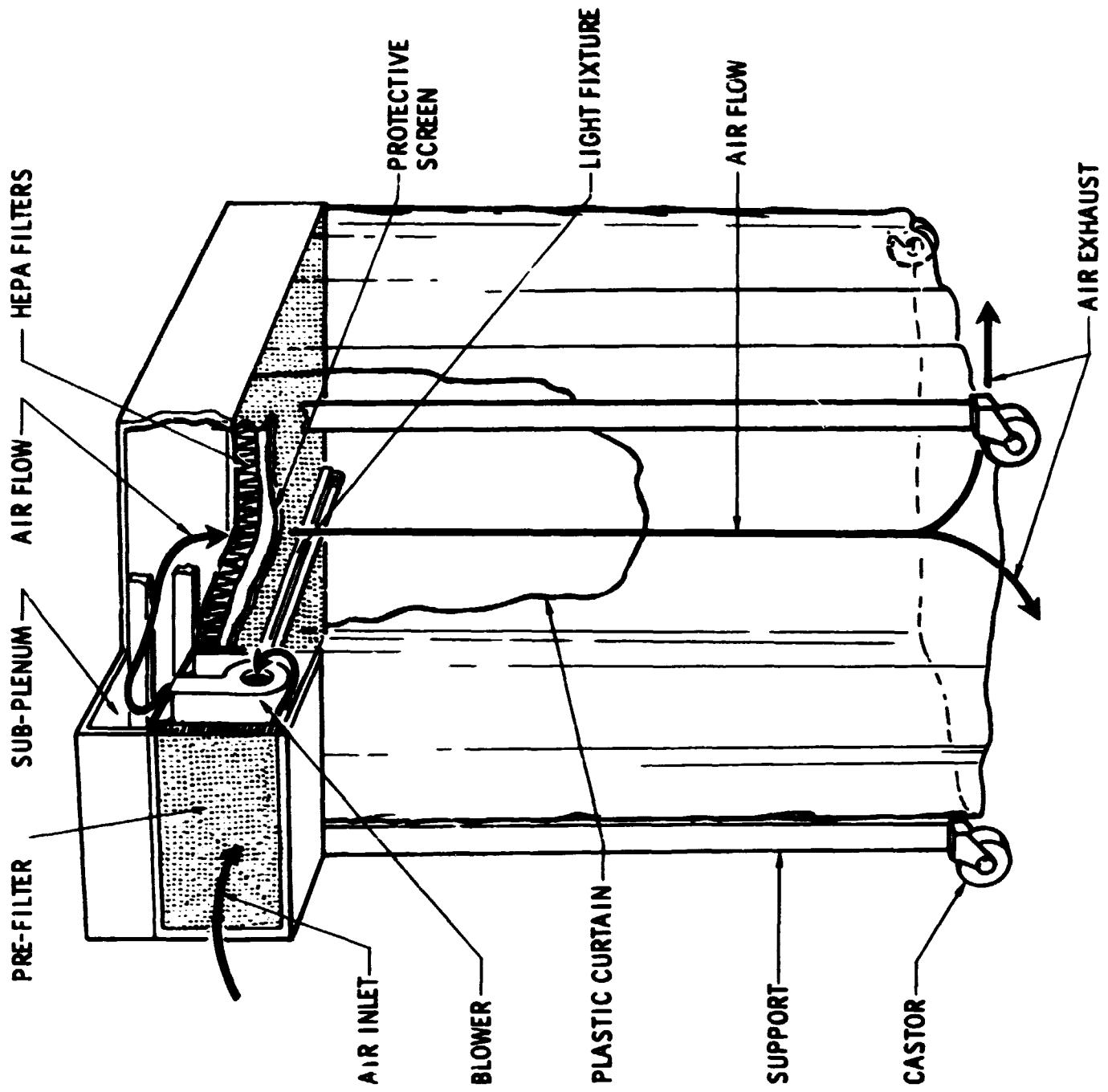

Figure 10 - Vertical Flow Curtain Room (Portable)



Figure 11 - Developmental Curtain Model of Laminar Flow Unit



Figure 12 - First Hospital Operating Room to Use Laminar Flow.
Bataan Hospital, Albuquerque, New Mexico.

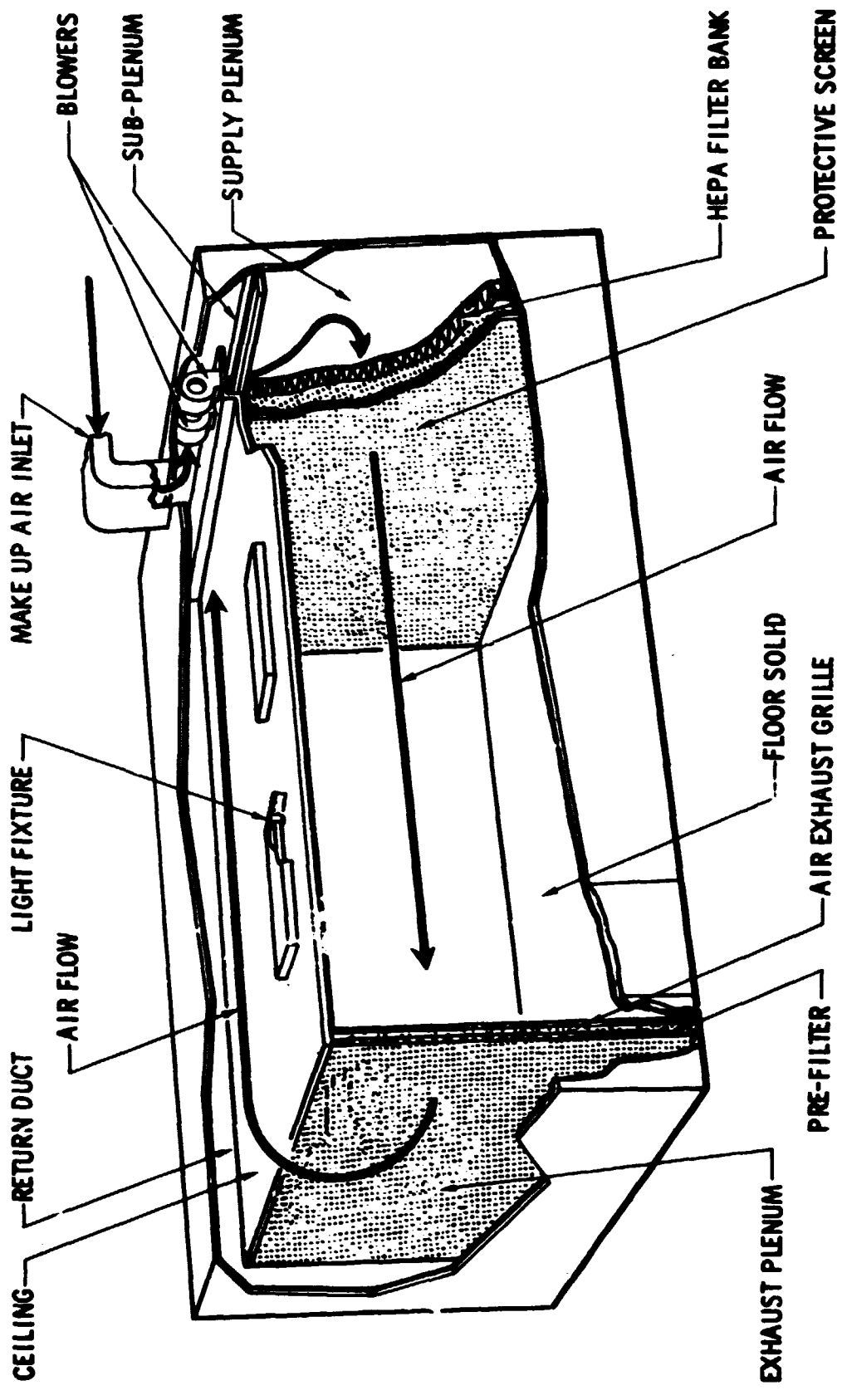

Figure 13 - Horizontal Flow Clean Room

The next slide (Figure 14) is a picture of a large industrial clean room in Albuquerque that is 100 ft long and 34 ft wide. The airflow in this room initially was 120 ft/min. The particle count in this room was much less than we had expected for a room of this size; the total count for particles $1/2 \mu$ or larger was less than 8,000 particles per cubic foot after it passed by a number of workers in the room. As you notice, the workers are wearing only brief smocks and shoe covers and have no head covering. The product that they were assembling in this room was not extremely critical; however, the cleanliness of this room was very good. This room was installed in the mid-1960's for electronic component assembly, and it turns out that the room was entirely satisfactory for the job. I might mention one other thing--a microbial count was made in the room and, even with all the people working, the microbial count was very low.

The next slide (Figure 15) shows another modification of the laminar flow system commonly called a tunnel room. If you have seen some of the newer laminar flow devices used in upgrading hospital operating rooms you may have seen this type unit installed in existing operating rooms. Rather than having its own air conditioning system, it takes the air from the existing room, filters it, and blows it through the enclosure. This type room, 50 or 60 ft long, will usually meet Class 10,000 (10,000 particles $1/2 \mu$ and larger), while the first work location would normally be Class 100. As with the curtain units, the prefilter system is very important on this device to eliminate the heavy load of particles from the room in which it is located. The cost of the tunnel room is reasonable, its installation is simple, and its performance is equivalent to the rigid-wall devices.

Next slide please (Figure 16). I would like to give you just an indication for the next few minutes as to how these devices perform. The lab technician here is holding a very simple smoke gun up near the ceiling of a vertical laminar flow room with the room in operation. Without disturbances the air is carried very quickly to the floor by the air stream. The airflow in this room, incidentally, was about 90 ft/min.

Next slide please (Figure 17). If you have been around people who have built and operated laminar flow rooms, you will know that one of their concerns is turbulence from interferences in the air stream. And certainly, this is a factor to be considered. It is something that you can live with, however, if you properly plan the design and layout of the room. Even in the turbulent area, the particle count is not nearly as high as you would expect in conventional facilities.



Figure 14 - Industrial Clean Room in Albuquerque, New Mexico

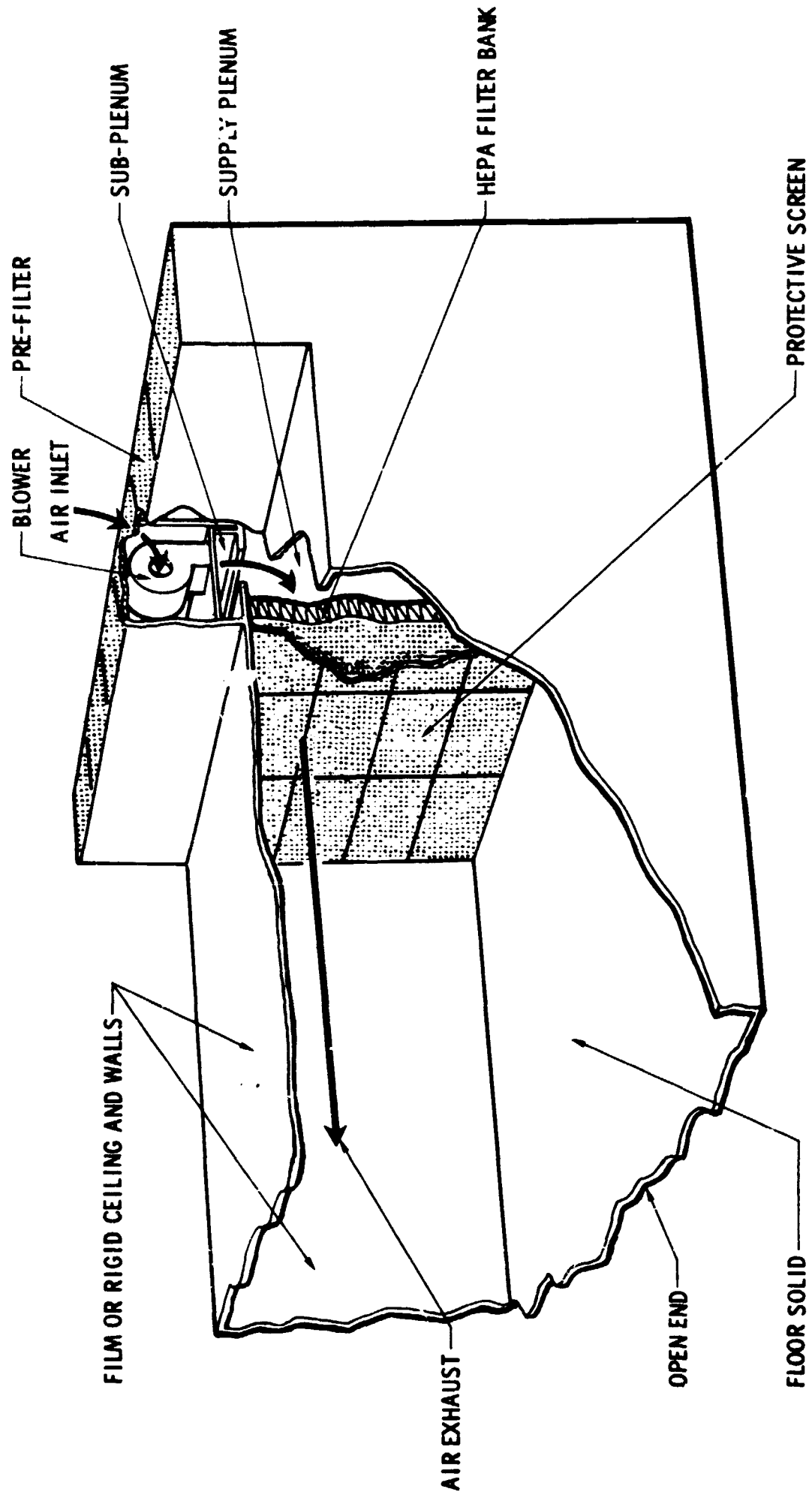

Figure 15 - Tunnel Clean Room



Figure 16 - Smoke Test in Vertical Laminar Flow Room

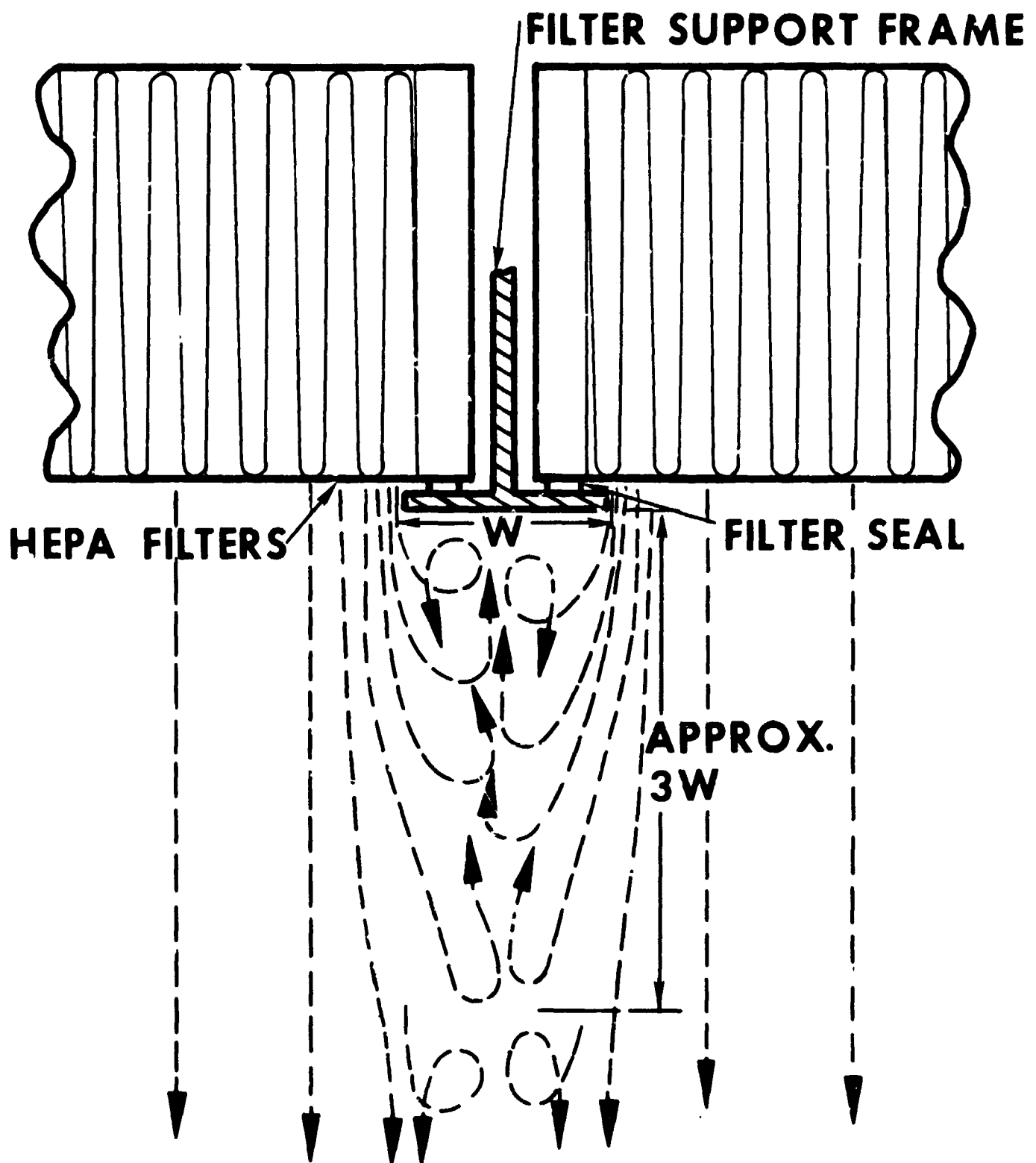

Figure 17 - Turbulence from Filter Support

C2

There is one rule of thumb that you can use for estimating turbulence from obstructions in a laminar flow room. What I call a recirculating turbulence would persist below an obstruction a distance of roughly three times the width of the obstruction. To give you an idea of what I mean by recirculating turbulence, if smoke were introduced at some point downstream from an obstruction within approximately three times the obstruction's width, some portion of this smoke would be brought back all the way behind the obstruction and again remixed and would circulate in this area for a somewhat longer period of time than it would if it were released out in the open area. This occurs beneath tables, behind people, etc., in laminar flow systems. The tests that we conducted at Sandia in the early days of this development showed that if we put a particle counter in an open area and introduced a single burst of smoke upstream, the smoke would be gone in a matter of fractions of a second and the count would be back to zero. In a turbulent area, however, we found that sometimes the detectable smoke might persist for periods of 10 to 15 sec. Even when you consider this, it is a rather rapid response time as compared to particle counts and turbulence in conventional rooms.

The next slide (Figure 18) carries this just a bit further in that we are talking about lamps being suspended from the ceiling. This might become important when these lamps were hanging low enough that people's heads or some operation might be in this turbulent zone. In this situation, particles could be recirculated for some period of time.

The next slide (Figure 19) again shows us another area of turbulence which is more critical than the kind that we have been talking about. When the air is flowing past only one side of an obstruction, this recirculating turbulent zone will extend roughly twice the distance as when the air is moving past both sides of the obstruction. In this case, the turbulence persists roughly six times the obstruction width downstream before the turbulence is carried on essentially with the speed of the air stream. You might also keep in mind that you can apply this same rule of thumb to horizontal flow rooms. So if you are laying out a laminar flow room, keep critical operations away from the walls as much as possible. These again are just rule of thumb guides that you might use in operating laminar flow rooms.

Next slide please (Figure 20). This slide presents a cutaway of the HEPA filter, showing its basic construction features. The filter media is simply one piece of filter paper pleated back and forth. The air travels through the filter by one separator, goes through the filter medium, and follows another separator out. The filter paper or medium is quite fragile and can be quite easily damaged. In most of the pictures you have seen, some kind of a screen or perforated sheet was placed on the room side of the filter to protect it from mechanical damage.

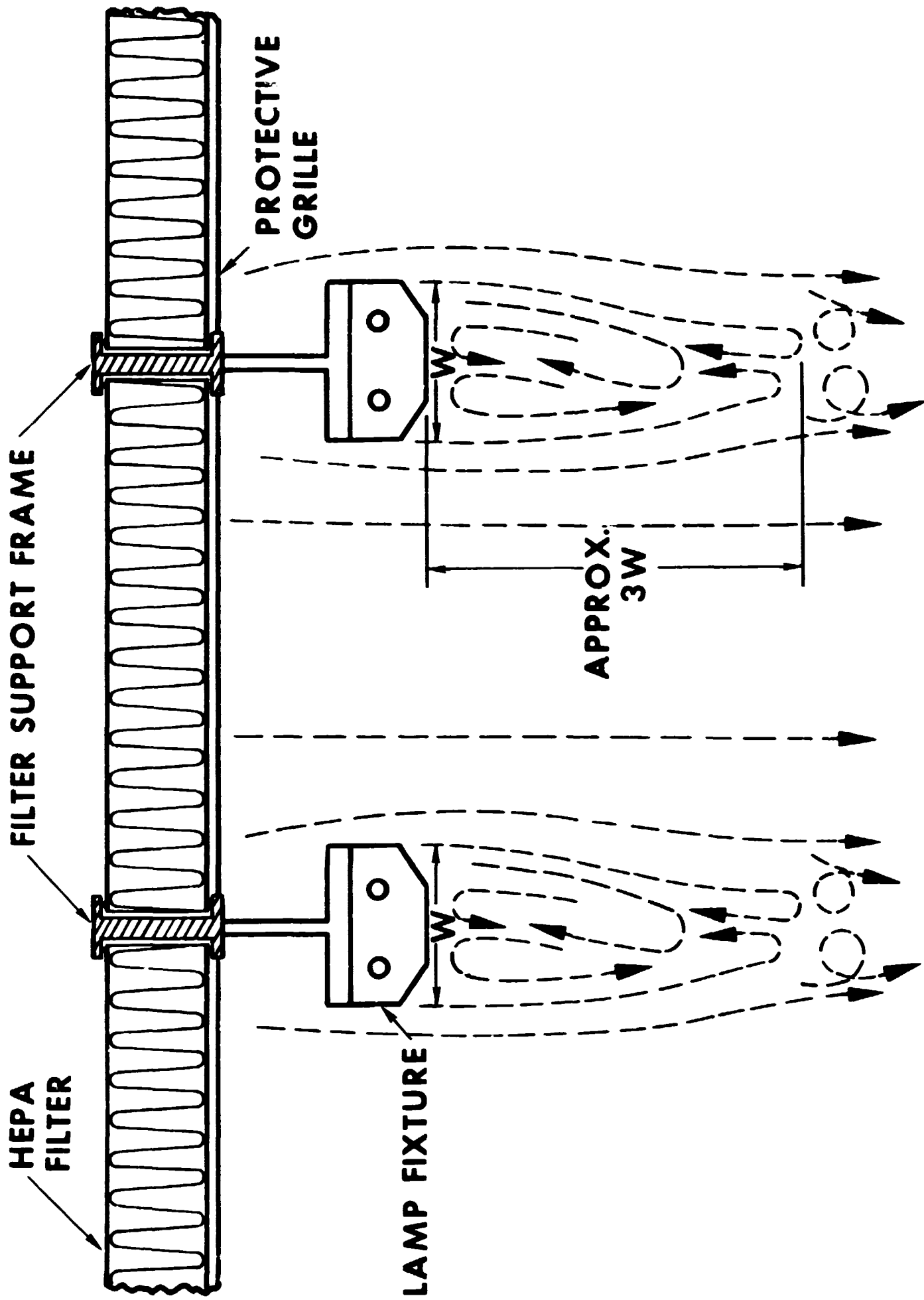

Figure 18 - Turbulence from Suspended Lamp Fixtures

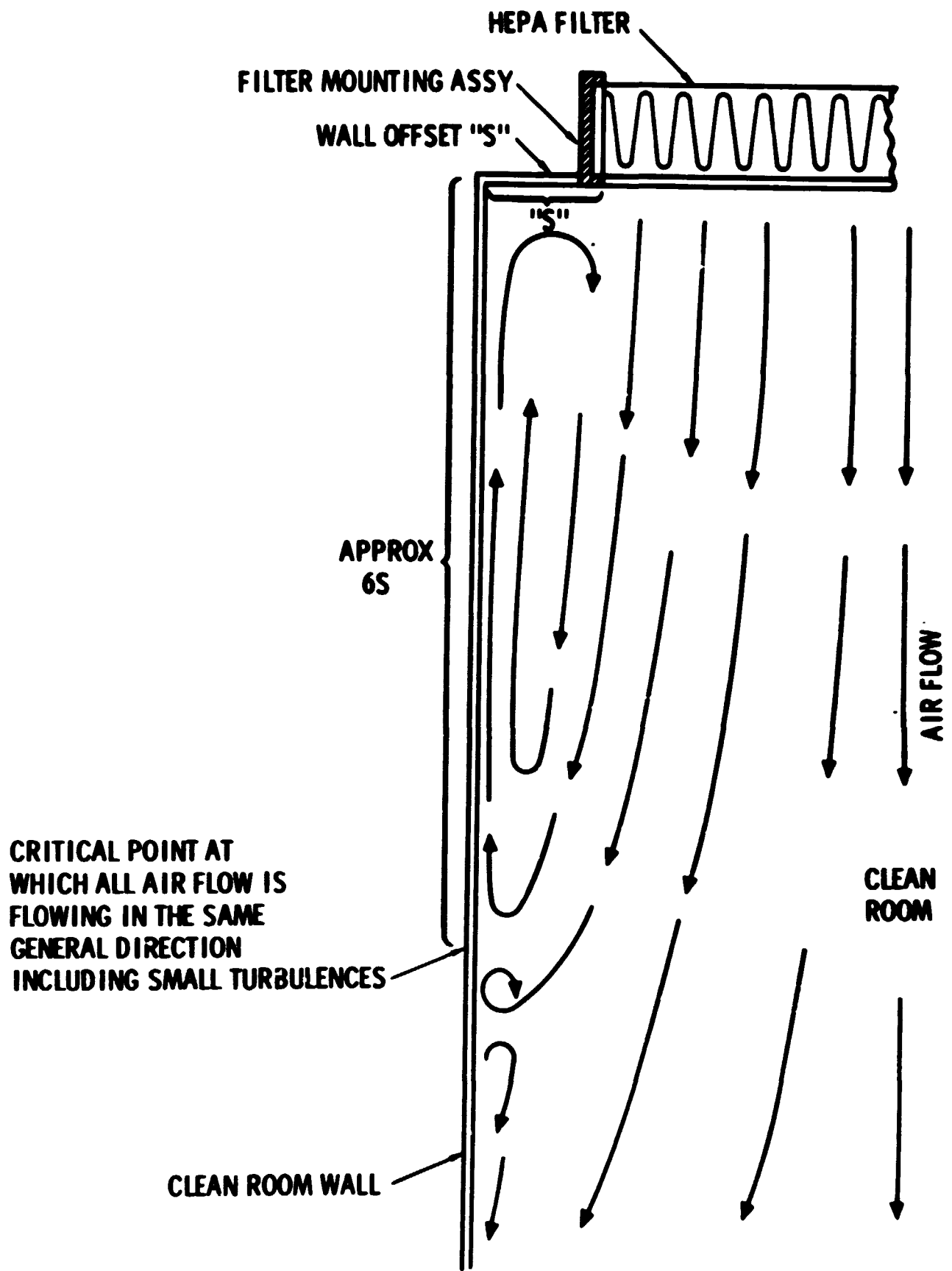
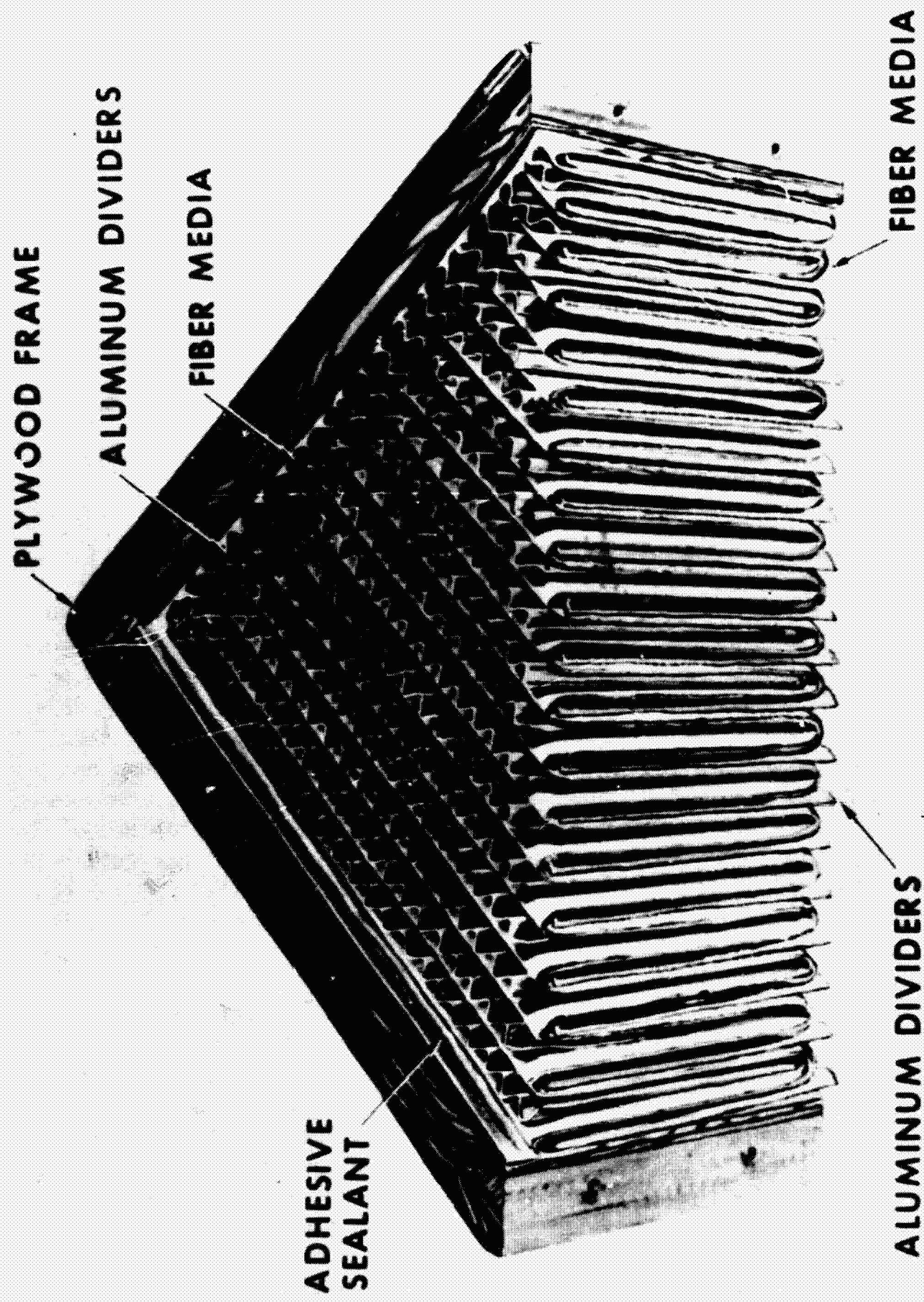

Figure 19 - Airflow Turbulences Caused by Wall Offset



HEPA FILTER SECTION

Figure 20

The next slide (Figure 21) indicates the location of possible leaks in HEPA filters. One of the greatest problems encountered with laminar flow devices is sealing of the filter bank. First, let us consider the filter holding mechanism attached to the clean room wall. When you are talking about hundreds of linear feet of ceiling, leaks in this area can become a problem. Such things as screw holes or just scratches along the clean room wall can provide channels through which the unfiltered air can migrate into the clean room. Of course, the more obvious potential for leaks are the holes in the filter medium itself. Some of these can be detected and repaired while others may require replacement of the filter. Note 3 indicates a leak around the filter gasket where the filter face seats on the filter support frame. We have actually seen weld blow-holes in welded joints as shown in Note 4. These are some of the common leakage points that must be checked if you install a laminar flow room in your hospital. Even though the total particle count in a room may be small, as a result of minor leaks, there is not much reason to put in an expensive installation like this and not reap the benefits of a leak-free filter bank.

Again I would like to call you attention to Figure 2, showing the Federal standard 209a curves, to give you an idea of what kind of performance we may get from various types of laminar flow devices. Remember that each of these curves represents a particle distribution in an area. Class 100 signifies a maximum of 100 particles $1/2 \mu$ or larger in size per cubic foot of air. Class 10,000 represents the same range of particle sizes, but permits a concentration of 10,000 particles per cubic foot of air and so on for the Class 100,000. The early nonlaminar flow clean rooms usually fell in the latter category, with particle counts somewhere between 50,000 and 100,000 particles per cubic foot. The cross flow or horizontal flow room, will fall in the Class 10,000 category 50 ft away from the filter bank. There are exceptions to this; the particle count may be lower but rarely is it higher than this. And of course the vertical laminar flow room throughout the whole room falls well within Class 100. The federal standard, if you are not too familiar with it, is a standard method of describing clean rooms in terms of these classes. This is the heart of the federal standard as you see it in Figure 2. I would caution you about reading this particular set of curves because the abscissa is a logarithmic scale. You will notice that the Class 100 curve, for instance, crosses the bottom line at a little less than 5μ . This is not zero; it is one particle per cubic foot. The next lower line under that would be one-tenth particle per cubic foot, meaning that you would expect larger particles, 10, 50, and 100μ , to occur in a Class 100 room only on a very low frequency basis. So do not interpret this bottom line as meaning zero; it does not mean that you could not have a clothing fiber a couple of inches long in a room on some very low frequency basis, even though it may be one in hundreds of cubic feet of air.

- NOTES:**
1. LEAKS IN FILTER MEDIA.
 2. LEAKS IN BOND BETWEEN MEDIA AND FRAME.
 3. LEAK IN GASKET BETWEEN FILTER FRAME AND SUPPORT FRAME.
 4. LEAK IN SUPPORT FRAME.
 5. LEAK BETWEEN SUPPORT FRAME AND WALL.

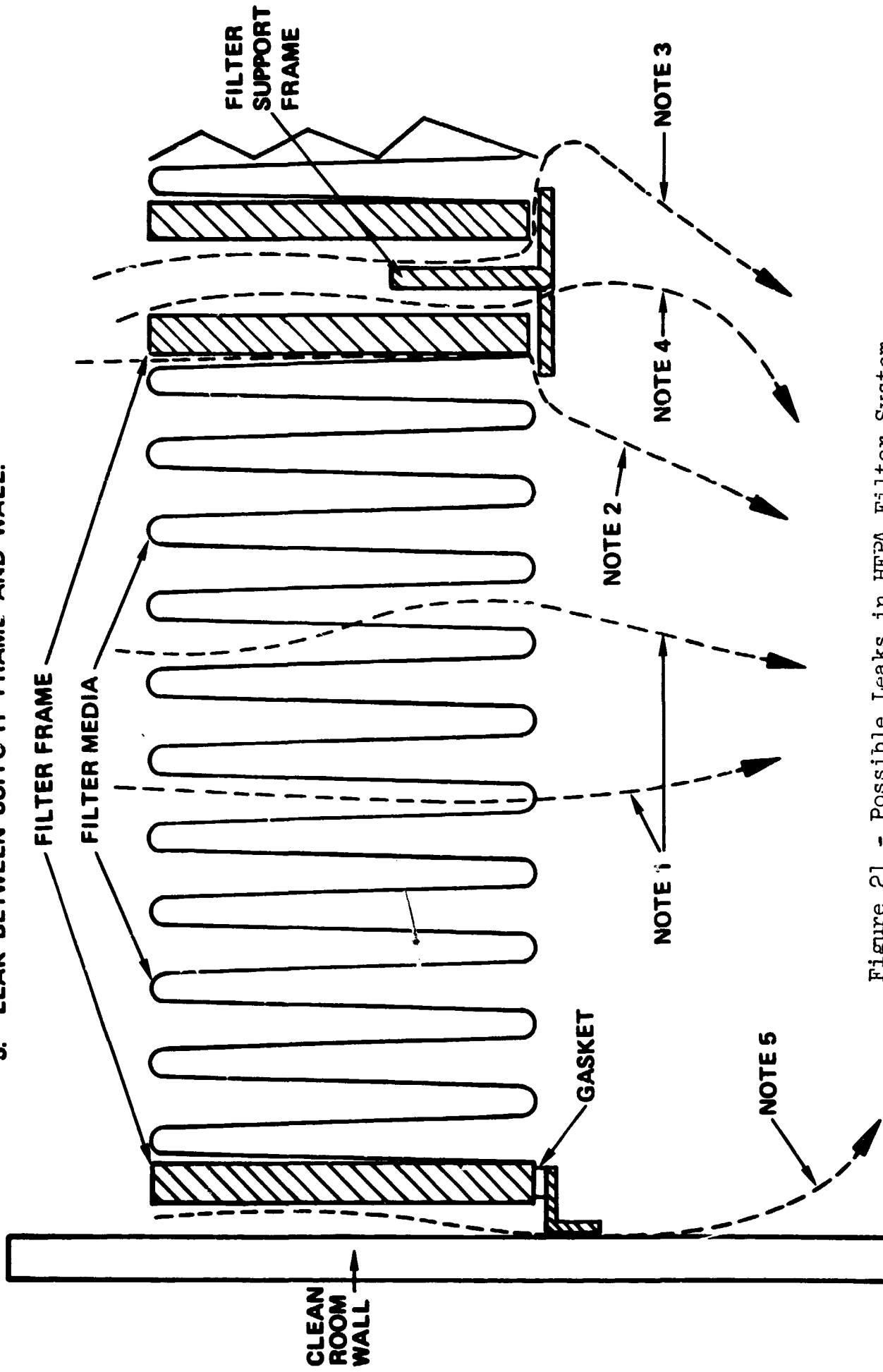
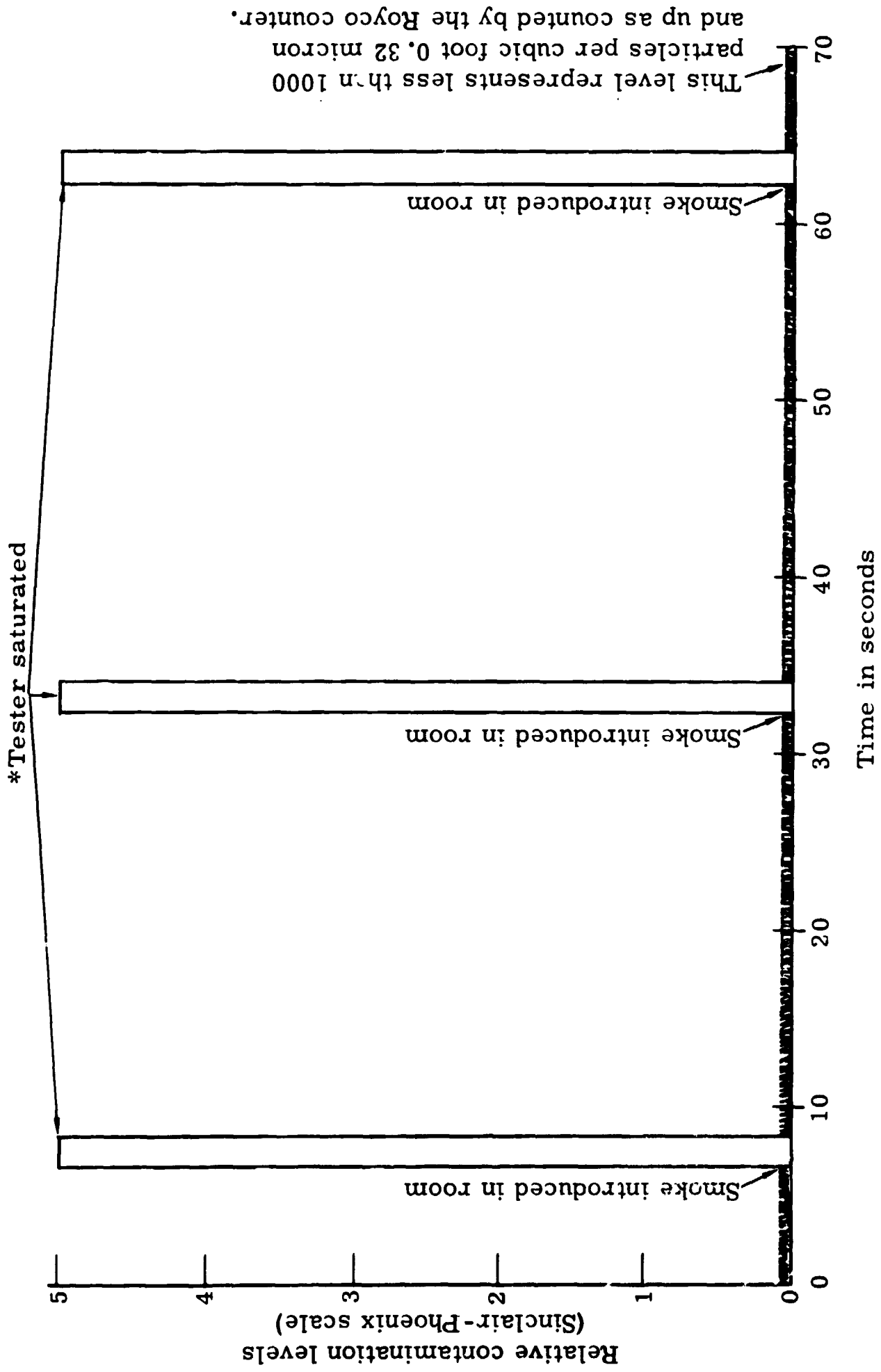

Figure 21 - Possible Leaks in HEPA Filter System

The next slide (Figure 22) shows the self clean-down response time of a laminar flow room. A cloud of smoke was introduced upstream of a sensitive photometer that responded very quickly to particle counts, although the room was probably responding more quickly than the counter. The scale that you see on the left side is a logarithmic scale; the zero line represents a threshold of sensitivity of about 10^5 particles. In most cases, complete recovery from the smoke cloud occurred in a matter of seconds. This will give you an idea of how quickly a laminar flow room can recover from a cloud of particles such as that produced by a person shedding a number of skin particles.

At this time we have about a 12-min film which portrays the laminar flow concept in operation and will enable us to reinforce our thinking about the basic principles of the operation of laminar flow devices. So if we could have the film at this time.



*Approximately 10^{10} particles per cubic foot.

Figure 22 - Room Self-Clean-Down Characteristics

SESSION II

PRECEDING PAGE BLANK NOT FILMED

Mr. Sivinski:

Well, we are ready to commence again, now that the inner man and the inner woman has been refreshed.

This afternoon the first four papers are going to be about different kinds of laminar flow environments for the operating suite. One of the things we are trying to do here is compare the environment, and not necessarily compare data, because some of the people I understand will have data and others will not. So we are not comparing data, we are bringing to the floor those kinds of environments which seem reasonable for an operating suite.

Our first speaker this afternoon is Dr. J. P. Nelson, an orthopedic surgeon from St. Luke's Hospital in Denver, Colorado. He got his B.A. from Grinnell, and his medical school was Northwestern; his orthopedic residency was at Mayo Clinic; and presently he is in the private practice of orthopedic surgery in Denver. His qualifications, he claims, are his interest in the area. The title of his paper this afternoon is "Use of Total Horizontal Laminar Flow Systems in Surgery."

Dr. Nelson.

PRECEDING PAGE BLANK NOT FILMED

USE OF TOTAL HORIZONTAL LAMINAR FLOW SYSTEMS IN SURGERY

J. P. Nelson, M.D.
Orthopedic Surgeon
St. Luke's Hospital
Denver, Colorado

Dr. Nelson:

I. INTRODUCTION

I would like to thank the sponsors of this conference for the opportunity to speak to you. My qualifications for this task are meager, particularly when compared with those of many others who are here. However, my two associates, Dr. Alba Glassburn, Jr., and Dr. Richard Talbott, and I have been interested in the subject of clean-air surgical modules for operating room use for nearly 2 years. This interest has been stimulated directly by the experience of Dr. John Charnley in England whose infection rate in total hip replacement was reduced dramatically utilizing the "greenhouse." This rate reduction was from 9 to 0.5%. Certainly, there are questions about whether his techniques and other variables might have contributed to this reduction, but at least it seems more than a coincidence that the "greenhouse" went along with this. Most of you are familiar with these figures, and I believe that many of the physicians here can also trace their interest in this subject to the same source.

The technology for clean-air surgical modules has been available and refined for many years. Credit should be given in this country to Dr. Whitcomb at the Baatan Memorial Hospital in Albuquerque and to Dr. Fox at the National Institutes of Health for their pioneering work in this area. Despite the available technology, it is of interest to note that it has taken an orthopedic procedure developed primarily in England to popularize the desirability of better operating room environments. As all of you know, surgical technology is also increasing in its capability. Many operations require large exposure of tissue for long periods of time, thereby enhancing the possibility of airborne contamination of the wound. In addition, relatively large amounts of foreign materials are being introduced into people as replacement parts. The prime medical areas for these replacements are in the realms of cardiovascular and orthopedic surgery. I am aware of no other operation in which such large amounts of inert, foreign materials are placed within the body as there are in the several varieties of total hip replacements. Since these materials have no intrinsic ability to combat bacteria, the introduction of only a few bacteria with them into the body at the time of surgery can cause a disastrous infection. Many of the infections now being seen by orthopedists are caused by organisms previously thought to be either saprophytic or of extremely low virulence. These include members of the gram-negative group such as Hafnia, diphtheroids, and Serratia, and Staphylococcus epidermidis. There are a number of possible explanations why these organisms have become more of a clinical problem including increased, widespread use of antibiotics, older patient populations, bacterial mutations and very likely were other factors which bacteriologists could more properly discuss. Suffice it to say that these organisms

are commonly found in the air and on personnel where surgery is performed and that they represent a hazard to the patient's wound and subsequent surgical result. And I should comment that we have sampled our air and we have found gram-negative bacteria in the air.

The possible economic consequences of a deep wound infection, aside from pain, functional disability and prolonged absence from home and job, can be seen by calculating the extra cost engendered by the one deep wound infection in our series of 170 total hip replacements.

Extra hospitalization - 4 months - 120 days at \$80.00
per day = \$9,600.00 plus the cost of three additional
surgical procedures, blood and special consultations.
Total probable cost - \$12,000.00.

If this infection had occurred in a wage earner, then the amount of salary lost and compensation paid can also be added to this figure.

On the basis of economics alone, then, we should consider any method which can reasonably be expected to reduce the incidence of infection. The fact that infection rates in most institutions are already quite low should not be used as an excuse to defer applying improved environmental technology to the hospital and particularly the operating room.

In our particular hospital, which I think is an average hospital, the published infection rate is approximately 1%. I honestly believe that this is open to some question because this is what shows up on the official medical record. There are many wounds which drain that are not cultured and there are instances where infections are hidden. I am sure that anybody who practices in a rather general hospital will find that this is true. I honestly think that the infection rate probably overall must be around 3% or so.

The medical literature on surgical infections is voluminous and great advances in the control and prevention of these infections have been made since the introduction of the principles of aseptic technique. The basic question of how does an infection start in the small percentage of patients who develop them has not been answered satisfactorily. Bacteria may be delivered to the wound by contact with unsterile utensils, gloves, etc.; by the air; or from the patient himself. The first method of delivery can now be controlled very well and, except for breaks in technique, should not be a factor. With the advent of the HEPA filter, we now have a method of controlling airborne delivery. From a purely scientific standpoint alone, then, the clean-air surgical module is important as a method of controlling one variable in the infection equation, and, therefore, allowing more intensive investigation of the patient himself as a source.

I should also like to be a little philosophical before going on and observe that it seems very important that there be a very close alliance between members of industry, the scientific community, and those involved in the day-to-day delivery of health care services when new technological systems are developed. The ultimate objective is improved, and if possible, more economical patient care, and this requires teamwork. It seems to me that there is no longer room for the autocratic surgeon or the ivory-tower scientist or the industrial entrepreneur whose sole motivation is profit. It appears that this conference, surprisingly sponsored by a government agency ostensibly devoted to outer space, is an example of the desire for teamwork in the application of new technology to health care.

II. INITIAL HORIZONTAL FLOW DESIGN CONCEPTS

When we initially investigated the possibility of installing a clean room, most of the designs extant at that time were of the vertical flow variety. It seemed that there are two drawbacks to this system, namely, the expense--and prices quoted to us when we investigated this ranged in the neighborhood of \$30,000-\$35,000 for installation of such a facility--and lighting--in the vertical systems which we visited, the lighting was cumbersome and usually required extra lighting facilities. I understand that now many of these problems with regard to lighting have been overcome. We therefore elected to pursue the horizontal flow design based on a room-within-a-room concept. We used as precedence in this design the published works of Fox and Martland. We were concerned about the possible adverse effects of turbulence, causing updraft contamination of the wound. However, there seemed to be little reason for this to occur.

Our initial design objectives then were:

- (1) Easy installation and maintenance.
- (2) Utilization of existing lighting.
- (3) Utilization of existing air conditioning.
- (4) Minimal disturbance of existing architecture.
- (5) Utilization of existing power supply.
- (6) Utilization of recirculated air.
- (7) Portability of the system.

(8) Decreased cost.

(9) Minimal interference with existing operating techniques.

Now, part of what we had in mind was that it would seem in our country that we have enough hospitals and we have enough structural facilities. If you are not going to start from scratch and build "brand-new" operating rooms, and there probably will not be too many of those built in the future, then you should be able to use existing facilities. These differ greatly, so that the system should have adaptability to existing architecture and it should be mass-produced if possible. The portability factor was added because surgeons usually have very set ideas about what is right and what is wrong. If you bring a new system into play in their operating room without their consent, they will generally rebel.

Such a unit could be moved around a hospital and used for reverse isolation of persons accidentally irradiated, of burn victims and immunosuppressed patients. These concepts were initially taken to the Martin-Marietta Corporation in Denver because of their experience with industrial clean rooms in spacecraft manufacture. Subsequently, a proposal for this type of system was submitted to NASA and this has recently been approved. Initial construction of the system and a program for evaluation of the use of ventilated space helmets with self-contained communication gear has begun. We hope to combine the space helmets with special impermeable gown materials so that the possibility of contamination from operating room personnel can be further reduced.

Last summer we also discussed our plan for a horizontal flow room with the Envirco Corporation of Albuquerque. Their design for this system was discussed on several occasions and finally approved in January 1971 (Figure 1). It was installed in March 1971, and we performed our first operations in it on March 15, 1971. The following discussion is based on our experience with this unit.

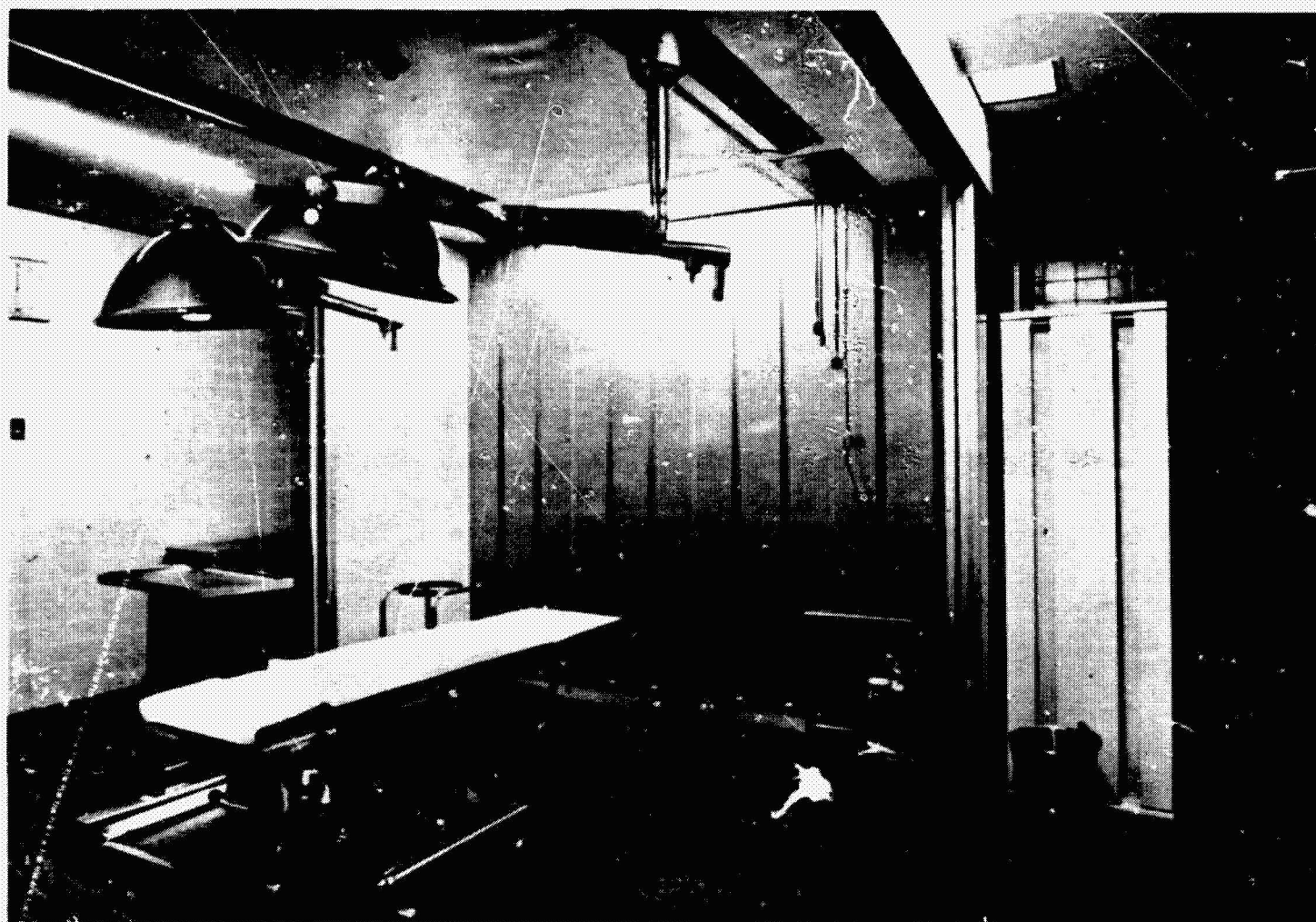

Figure 1 - Horizontal Laminar Flow System in St. Luke's Hospital, Denver

III. OUR EXPERIENCE WITH THE HORIZONTAL FLOW ROOM

Because of our desire to interfere the least possible amount with normal functioning of the operating suite at St. Luke's Hospital in Denver, we chose the least desirable operating room. I should note that the operating suite was constructed in 1968, and that the air exchange within each of nine rooms is 12 to 14 times per hour. The room we chose has dimensions of 18 ft by 18 ft and is located next to the operating suite air conditioning equipment which generates a substantial noise level. The air conditioning had previously proved to be somewhat inadequate, particularly on hot summer days. We felt that if we were going to test the system adequately, we should do it under the most adverse conditions available.

The system consists of two portable blower units located on either side of the plenum. The plenum extends from the ceiling to the floor with the dimension of 10 ft in breadth. The walls are composed of one solid section approximately 4 ft in length and an additional sliding door section of approximately 8 ft in length. The sliding doors are suspended on a rigid extension from the plenum itself with one tie rod into the ceiling. They are made of heavy duty glass with aluminum frame and slide quite easily. These doors were constructed so that they can slide back towards the plenum to provide easy maneuverability for the staff and during times between operative cases. The solid side walls are advantageous because they keep the flow directional for a distance of approximately 3 ft. In this base area we keep our back tables with instruments while the patient is prepared.

I shall try now to evaluate the system under a series of headings, with appropriate comments under each heading.

A. Maintenance

Each blower unit contains the prefilters. The blower units are on casters and are easily detachable from the plenum so that they may be serviced if necessary outside the operating rooms. The materials utilized to construct the system have proven to be quite easily kept clean. We have noticed absolutely no dust within the room or on the lights. Our contract with the manufacturer has provided for quarterly inspection and testing of the HEPA filters and other hardware to be certain that they continue to measure up to specifications. We have had no difficulties with any of the mechanical or motorized parts of the system. We turn the system on at approximately 5:30 in the morning and continue to run it until the conclusion of the operating schedule.

B. Acceptance of the System by Personnel

Before installation, we made a determined effort to inform all personnel in the operating suite of the purpose of the system and its approximate dimensions. This included both the surgical staff and the operating room nursing staff. Consequently, we have had little difficulty with personnel acceptance and since there are eight other rooms, none of the surgeons who might object have voiced any strenuous objections. We have carefully questioned our anesthesiologists, and occasionally they mentioned slightly excess noise which is distracting. They have not felt that the noise interferes with auscultation of the heart through an esophageal scope. They have not been aware of the airflow.

C. Utilization

The sliding doors have made it quite easy to get the patient into and out of the room. Generally, we transfer the patient from his bed in the hallway outside the room to the operating table. Preparation of the skin has been done routinely within the enclosure itself. We have generally done all of our preparation including draping with one sliding door part way open. We then remove several stands from the room and move the patient deeper into the room just prior to beginning the operation. We have had to make modifications in our back table setup by reducing the number of tables and consolidating our instruments. We do not use special instrument packs for the total hip replacements. It has been somewhat cumbersome to get two x-ray machines into the module in order to take biplane x-rays for fractured hips. We have solved this problem by placing the patient obliquely within the room. Our anesthesiologist has utilized tanks of oxygen, cyclopropane and nitrous oxide as well as a rather large stand containing emergency drugs and a cardioscope. This does cramp the open end portion of the room. We are in the process of designing more adequate shelving on the existing operating room wall to take much of this equipment and this should give us considerably more space at the open end of the system. Even though our module is in a rather small room, we have found that the 4 ft leeway on either side of the module has provided satisfactory room for observation of procedures as well as movement of support personnel. There is an approximate 3-in. space between the bottom edge of the collapsible wall and the floor. Tubing, cords, and wires can easily be led out beneath this space. On the first day of use of the room several of us noted a brief feeling of claustrophobia. However, this feeling rapidly passed and, subsequently, we have not experienced it.

D. Noise Level

The noise level within the room has been measured at 64 decibels. I am told that this is the approximate amount of noise which a standard room air conditioner produces. We are able to converse in a normal tone of speech with ourselves and the anesthesiologists. The noise level has not been irritating after being in the room several hours. However, we are unable to converse with people outside of the room except if they come to the open end of the room. Certainly a loudspeaker system would be helpful in this situation if teaching were of prime importance.

E. Surgeons' Comfort

We have noted no discomfort from the moving air which is essentially imperceptible. Since we thought about working within a 10 ft by 10 ft enclosure for a long time, we have not found any difficulties in adapting our procedures to this space limitation. As will be noted below, we have had some difficulty with increasing temperatures during the day. Particularly during strenuous procedures, the warmth of the room has proved to be somewhat uncomfortable.

F. Potential Hazards

There are two hazards which I think deserve some mention, and about which I think there is some confusion. The first is that of a leak of anesthetic gas, particularly combustible anesthetic gas. We believe because of the rapid exchange of air, which in our system is 90 ft/min, that there is a very rapid mixing, and should even a very large amount of anesthetic gas such as one or two canisters of cyclopropane escape, that this amount of gas would be rapidly mixed to a subexplosive level. We have done some calculations regarding this and it would appear that at least two canisters of cyclopropane escaping into that 18 ft by 18 ft by 9 ft room would have to be released in order to come close to an explosive mixture. And as I recall, the percentage on that is something like 2.5%. Certainly more expert opinion than this should be gotten before we make a definitive decision about that. With regard to this, in a horizontal clean room, as most of you know, the public health standards are that electrical outlets should be 5 ft above the floor. Now, if you are mixing and the reason for this is the gas is heavier than air and that it layers out and if you have a spark, you should not have any possible spark source below 5 ft. Well, actually, this is a lot of nonsense because if you bring an extension cord in, you have a tremendous spark source, and there are spark sources going on all the time. If you have a clean room with very rapid mixing, then this negates the 5-ft level, essentially. And I think that there are some

questions, as far as code requirements are concerned, about the utilization of a clean room, and these ought to be discussed and some decision be made about it.

The second possible hazard is an electrical leak, and I am sure you have heard much about this; I know very little about it except that it can and does occur, particularly where there are electrical installations, and therefore certainly explosion-proof electrical connections and isolation of the motors should be done.

G. Patient Acceptance

I think many people who are doing this type of surgery have found that patients are becoming more sophisticated and have read stories particularly about hip replacements. They are aware of the existence of clean room facilities, and many ask about them. It is our belief that the environment can only be improved by using such a system and we should, therefore, make it available to our patients. There have been no adverse comments from patients.

H. Studies

During the brief time that the system has been available to us, we have performed the following studies:

The first one is that with smoke, and we just have a small smoke gun, and we have used this to determine the effects of turbulence, and we have found that there is turbulence. We have found that we must not allow obstructions between the plenum and the wound. If this is done, then there is no turbulence in the wound area; if back tables are allowed to be placed in front of the plenum, there is substantial turbulence, and there is a tendency on some tests for the air to rise from the floor towards the wound.

Temperature: As noted above, the room in which we placed our module has relatively poor air conditioning. The average room temperature is approximately 72°F, and generally speaking, at least in warm weather, we are unable to lower it below that temperature. The motors give off 14,000 Btu per hour. In addition there are generally between six and eight personnel in the outside operating room and module, and, of course, the surgical lights also give off heat. With this background in mind, we have found that the temperature during the day does rise an average of 3.9°F over an 8-hr period. During rather strenuous activities, we do notice some perspiration. We believe that this may be a place for additional air conditioning in our system, and it is certainly a consideration in installation of this type system in existing facilities.

Humidity: We have measured the humidity in our room at 35% and 46%, and are in the process of trying to make the humidity more constantly approach the desired 50% level.

Bacterial cultures: Initially we sampled a regular room during four total hip procedures with a total sampling time of 11.3 hr. We collected samples from the time the patient was brought into the room until the time the patient left the room. The average number of bacteria collected in our regular operating room was 3.9 bacteria per cubic foot of air sampled. These were bacilla species, micrococcus, diphtheroid and Staphylococcus epidermidis. We did not collect any Staphylococcus aureaus. Sampling was done with a Gelman bacterial collector. We noted, as others, that with the door open our counts rose.

In the clean room environment we have monitored the room in three separate ways. The first was by affixing agar plates to standards at 1-ft intervals in a vertical fashion. There were seven plates for every standard. We have done this on four separate occasions with two standards on the opposite side of the wound and two standards on the same side of the wound. These were placed downwind of the surgeons. Total exposure time was 90 min on one test and 115 min on the second test. Taking into consideration that our room air was moving at 90 ft/min, we calculated that we were sampling an approximate 784 cubic feet per plate. The total number of colonies grown was 15, giving approximately 0.5 colonies per 1,500 cubic feet. All of the bacteria were Staphylococcus epidermidis or diphtheroids. It was noted that there were more bacteria on the wound side downwind where the concentration of personnel was. We used the Gelman counter to sample the room in areas on two occasions. On one occasion we obtained a figure of 0.14 bacteria per cubic foot and on another occasion 0.63. Both of these were done downwind; one, on the wound side where the personnel were; the other, lesser count, on the opposite side. Our last method of sampling in the room was by means of a sterile suction tube at the wound site collected to the Gelma sampler. Collection time was 3.4 hr and the average count was 0.1 bacteria per cubic foot.

I think these studies speak for themselves and that there has been a significant improvement.

One last subject is particle counts; we measured this on one occasion and in the hallway we got 10^5 ; in the external room, 10^4 ; downwind of the surgeons, 10^2 - 10^4 ; at the wound, 1 - 10^2 ; and upwind, 10^0 . We have done approximately 150 operations in this room; we have had no infections in this 2-month period; there have been 30 total hips, but this experience is far, far too limited to draw any conclusions about that.

I should like to summarize by saying that it has been our impression that the concept of the clean room can do nothing but improve the environment and therefore render more protection to the patient. The question to be resolved is whether the vertical system or the horizontal system is superior in this respect. Personally, I believe that there is little to choose from in terms of the objectives which are desired. We have found that the design of our room has generally been well conceived and has required very minimal modifications in existing superstructure and our techniques.

Thank you.

Mr. Sivinski:

Thank you very much Dr. Nelson.

That was the paper on the horizontal laminar flow; the next paper, "The Use of Total Vertical Laminar Flow in Surgery," will be given by Dr. Charles O. Bechtol, an orthopedic surgeon from Hollywood, California. Dr. Bechtol received his degree in medicine from Stanford, did his residency in orthopedic surgery at Wisconsin General Hospital, and also at Merritt Hospital in Oakland; subsequent to that he became a professor of orthopedic surgery at Yale and is now a professor of orthopedic surgery in Los Angeles, California. "Use of Total Vertical Laminar Flow Systems in Surgery"--
Dr. Bechtol.

PRECEDING PAGE BLANK NOT FILMED

**THE USE OF TOTAL VERTICAL LAMINAR
SYSTEMS IN SURGERY**

**Charles O. Bechtol, M.D.
Hollywood Presbyterian Hospital
Hollywood, California**

Dr. Bechtol:

The problem of surgical infection has been improved greatly in the past few centuries and has gone through many stages, such as the antiseptic phase, the aseptic phase, the development of the proper principles of surgical technique and the antibiotic phase. The achievement of a low infection rate is an extremely complex problem and involves the cooperation of a large number of people.

The clean room technique may offer an additional factor in the fight against surgical infection. It is quite evident that extensive careful studies will be necessary to evaluate and clarify the role of the clean room in fighting surgical infection. The purpose of this paper is to report the experience of over 850 hr in a vertical flow clean room surgical enclosure and to state the surgeon's point of view on the desirable design criteria for such a clean surgical enclosure.

DESIGN CRITERIA

The two major considerations in design of a clean operating enclosure are:

1. A Class 100 unidirectional flow area in which to successfully accomplish the surgical procedures.
2. An adequate sterile envelope or operating suit for the surgical personnel.

THE CLEAN OPERATING ENCLOSURE (Figure 1)

1. Size

An enclosure 10 by 10 ft appears to be adequate for almost all procedures. (Mr. Charnley's original room was 7 ft by 7 ft and was satisfactory only for the very specialized hip operation.) Minimum height of the ceiling in the clean area should be 7 ft 6 in. (The installation discussed here is that of a clean enclosure placed in an existing operating theatre. This has the advantage of being less expensive, it excludes the nonsurgical personnel, it can easily be placed in an established operating room and if necessary can be dismantled and moved to another area. Further discussions are related to this type of enclosure.)

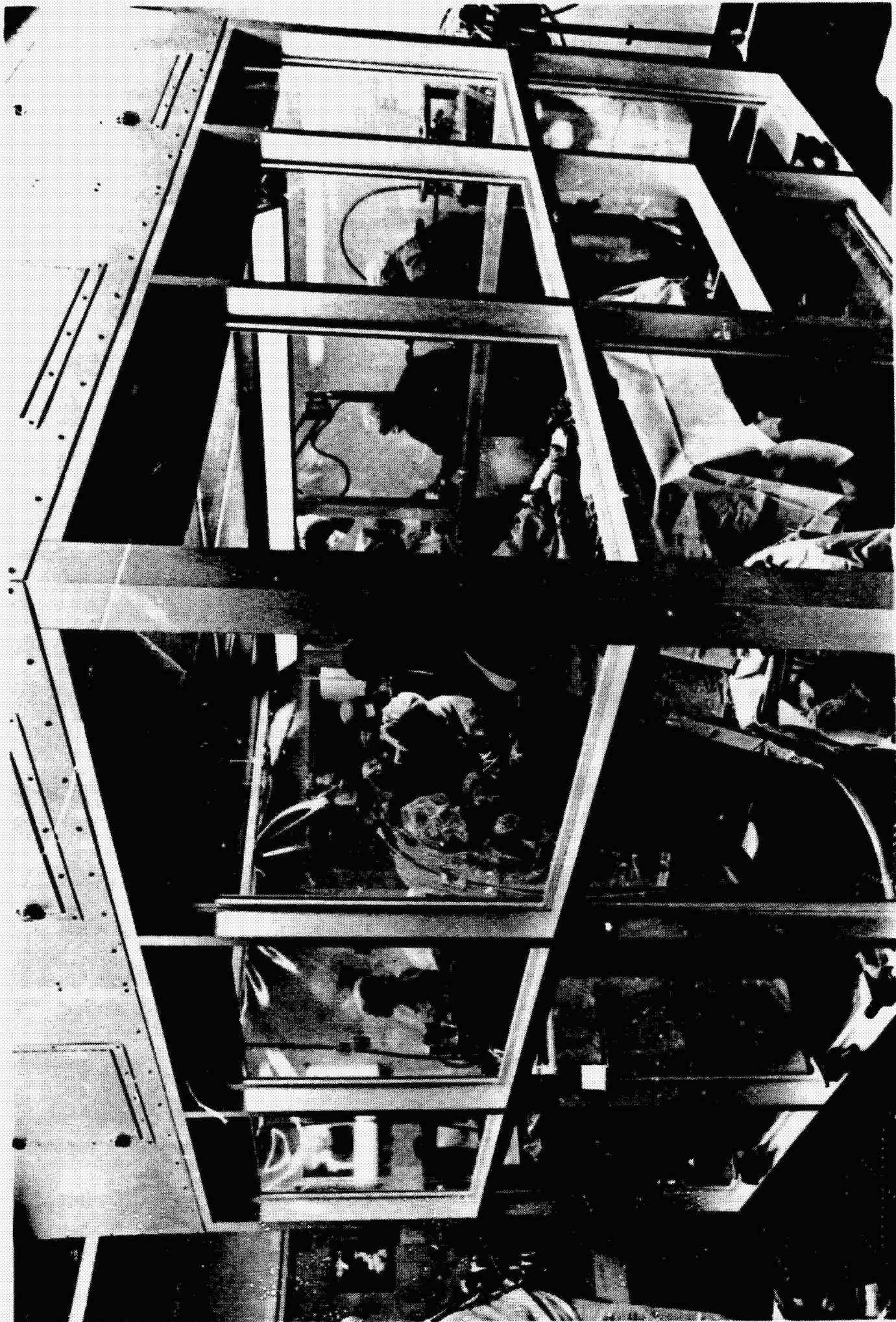

--Los Angeles TIMES Photo

Figure 1 - Vertical Laminar Flow Operating Room at Hollywood Presbyterian Hospital, California

2. Mobility of Surgical Personnel

This is perhaps the most important of all criteria and here the clean room application differs markedly from industry. In industry it is possible to place the work and the worker in such position that the flow of air will be in the proper direction and there will be no possibility of contamination by reverse turbulence. In the operating room this is not possible because the surgeon must be free to move about the patient in any position as necessary. This particularly applies when a complication of the operation arises, when complete freedom of mobility by the surgical team, to move about the patient and to change from one side to another, is an absolute necessity. It should be noted that this necessity for mobility applies not only to the surgeon but the entire team as well as instrument tables.

3. Lighting of the Clean Surgical Area

The conventional type of lighting with its large overhead surgical lights is difficult to apply in the clean room concept because it can create reverse turbulence. Several small spot lights of appropriate size can solve this problem. Such lights which are freely mobile will not cause reverse turbulence and can give shadow free illumination. The use of fibre-optics may be helpful in illuminating a deep surgical cavity, though it must be remembered that fibre-optics do not give shadow free illumination but a point source of illumination.

4. Access to the Clean Enclosure

The author's experience has been with a clean enclosure with three fixed walls and a transparent curtain enclosure of the open end. This allows easy entry of the operating table and personnel. The curtain then excludes the anesthetist and the patient's head from the operating area. In a room which is 10 ft square additional equipment such as portable x-ray machines and so forth can have access through this open end. It is possible that in some situations additional doors in the side walls would be useful to bring in other types of equipment and the installation would also be entirely satisfactory if all four walls were made of transparent curtains.

It is also necessary to have a pass-through window so that additional sterile surgical implements can be passed in as the operation progresses. This window should be placed at the same height as the instrument table to be used in the room. Because of the flow of clean air out the window, the lower edge of the window can be draped and used as a sterile area.

5. Communication

Because of the walls of the clean enclosure, communication is a little limited from the inside to the outside; however, the use of a small tap bell to get attention allows the surgical team to transmit their needs to the outside personnel. This is done through the pass through window. If teaching is to be carried out it is a considerable advantage to have a public address system with the microphone under the surgeon's mask.

It should not be necessary to have special equipment inside the enclosure for communication within, between members of the team. This can be necessary if there is a considerable amount of noise from the exhaust tube used by the surgical personnel. This will be discussed in greater detail later in describing the sterile envelope for the surgical personnel. The noise of the clean enclosure blowers should not be higher than the usual level of a room air-conditioner.

6. Temperature and Humidity Control

The motors and the surgical team generate some heat. In many already established operating rooms, particularly if they are older, the air conditioning system may be marginal. This should be carefully evaluated and additional air-conditioning capacity added if necessary (the operating room also generates considerable lint and lint filters should be added to the HEPA filter system).

THE STERILE ENVELOPE FOR THE SURGICAL TEAM

The sterile envelope for the surgical team has two important purposes; first, it should exclude the personnel of the surgical team as a source of contamination of the operating field. It has been well established that skin scales, dandruff, particles of hair and the exhaled breath of the surgical team are the greatest source of contamination in the operating room. A second and equally important function of the sterile envelope is to allow the surgical team to operate in comfort and with free mobility.

1. Adequate Air Exchange

An adequate exchange of air is necessary for the comfort of the surgical team. It should be particularly noted that in many orthopaedic operations the surgeon may be doing the equivalent of hard physical labor.

The addition of an exhaust tube (Figures 2 and 3), under the surgeon's mask, not only removes his expired air and removes a possible source of contamination but affords him much greater comfort, since he is continuously breathing fresh air. The flow of air through the exhaust tube must be a compromise between an adequate amount for ventilation and an excessive amount which can become very noisy. Minimum flow is about 20 cubic feet per minute. Greater flows can be accommodated and are more comfortable; however, a noise level can easily be reached if turbulence is created in the tube. It should be noted that a tube about 3/4 in. inside diameter is the minimum to allow adequate flow without excessive noise. It is also necessary to have more than adequate apertures in this tube because as the tube shifts it may come against the surgeon's mask or against his face and occlude some of these apertures. It is ideal to have the apertures 3 to 4 times the area of the tubes.

2. Air Cooled Personnel Envelope

The use of the exhaust tube under the surgeon's mask gives the opportunity to make the surgeon much more comfortable than usual by drawing air up underneath his gown and thus, making his entire gown air cooled. This can be most effectively accomplished if he wears a hood and some type of transparent face plate. This forces all the air to flow up under the gown before breathed and then exhausted through the tube. Our experience to date has been to use a motorcyclist's "Bubble shield" attached to a welder's head piece. This is covered by a cloth or paper hood, the lower portion of the hood being enclosed inside a paper gown. The increase in comfort to the surgeon, particularly when he is working hard, is truly remarkable.

3. Acceptable Air Noise

An excessively high rate of airflow or improperly designed tube openings can create an unpleasant hissing noise. This may be so severe that communication between the operating room personnel may be very difficult. I know of one instance in which the flow of air was carried to such an excessive degree that it was necessary for the surgical personnel to wear earphones and directional microphones in order to communicate with one another within the enclosure.

4. Ease of Communication

The use of a complete personnel envelope, as mentioned above, does not interfere with communication within the operating enclosure. Excessive noise either from the filter system or particularly from the exhaust tube will interfere with this ease of communication and should be avoided.



Figure 2 - Exhaust System



Figure 3 - Exhaust System Under Sterile Envelope

5. Absence of Fogging of Face Shield

The "motorcycle bubble mask" may fog if an adequate flow of air is not supplied by the exhaust tube. The face shield will also fog if the surgeon does not wear a conventional surgical mask over his exhaust tube. In the absence of the conventional surgical mask, his expired air will not be deflected and the face shield will fog unless a very high rate of flow is used in the exhaust tube. This high rate of flow frequently leads to excessive air noise. With the presently available design of hoods and face shields it is felt most satisfactory for the surgeon to wear a conventional surgical mask with his exhaust tube beneath the mask.

The preceding five subjects related to the comfort of the surgeon, the following four in increasing order of efficiency and complexity, relate to his exclusion from the surgical area as a source of contamination.

6. Sterile Personnel Envelope (not face or back)

The simplest arrangement, and that used by Mr. Charnley initially, is a conventional operating gown in which the back of the gown is not considered sterile and a hood covering the personnel's head and neck with the exception of the face.

7. Sterile Personnel Envelope (not back of gown)

The addition of some type of transparent face plate allows further exclusion of the surgical personnel and gives additional safety for contamination from the area of the face and expired air. The back of the gown is not sterile; however, for the usual surgical procedure it may be an unnecessary refinement to have the back of the gown sterile.

8. A Completely Sterile Personnel Envelope

By the use of a gown which has an integral hood and is closed down the back, it is possible to entirely enclose the surgical personnel. This coupled with a transparent face plate which can be sterilized allows the entire exterior of the personnel envelope to be sterile. This raises some additional complications in sterilizing and in gaining entrance to the operating room. There are some surgical procedures, however, in which this may be desirable.

9. Cough and Sneeze Safety

The sudden blast of air released by a cough or sneeze contains many infected particles. It is considered wise to prevent the escape of these particles if possible. If the surgeon does not wear a conventional surgical mask a very high flow of air in the exhaust tube is necessary to give cough safety. This may lead to problems of noise level and communication. We have determined that cough and sneeze safety can be accomplished if the surgeon will wear a conventional mask since this deflects the force of the blast and entraps most of the sneeze or cough particles.

SUMMARY

The surgical experience of more than 850 hr in the clean operating room has been presented with design criteria which seemed desirable from the standpoint of the surgeon. It is evident that an extensive and carefully coordinated period of evaluation will be necessary to define the place of the clean unidirectional enclosure as an additional factor in reducing infection in surgical procedures.

Mr. Sivinski:

Thank you very much sir.

We have one more paper before the coffee break. This is by Dr. Richard E. Clark, who received his Bachelor of Science in chemical engineering from Princeton University, got his degree in medicine from Cornell University, Master's of Science in Surgery from the University of Virginia, his internship and residency between 1960 and 1967 in general surgery and thoracic and cardiovascular surgery at the University of Virginia, Charlottesville, Virginia. From 1967 to 1969, he was Assistant Chief and Director of Laboratories of the Department of Thoracic and Cardiovascular Surgery at the National Naval Medical Center in Washington, D.C., and in 1969 he went to his present position, which is Assistant Chief, Division of Cardiothoracic Surgery, and Director of the Surgical Laboratories at Washington University and Barnes Hospital in St. Louis, Missouri. The title of his paper is "Use of Vertical Laminar Flow Systems Over the Operating Field." You notice now we have had horizontal and vertical flows in general areas; we are now going into specific subsystems of these and this one is on the vertical laminar flow system over the operating field.

Dr. Richard Clark.

PRECEDING PAGE BLANK NOT FILMED

USE OF A VERTICAL LAMINAR FLOW SYSTEM OVER THE OPERATING FIELD

Richard E. Clark, M.D.

and

Kurt F. Bemberg, P.E.

Washington University and Barnes Hospitals Complex
St. Louis, Missouri

Sixteen months ago, concern over bacterial contamination of operating rooms prompted a culture survey. High bacterial counts were obtained and a more extensive investigation was undertaken. Prosthetic material handling, scrubbing, gowning, and room cleaning techniques were all evaluated. Regulation of the steam autoclaves and gas sterilizers, and the aerating procedures were evaluated. All personnel were cultured repeatedly and a variety of other factors were also investigated. Settling plate and swab cultures were taken. High counts of Staphylococcus albus were found consistently in the cardiac operating room. The room was closed down for 3 weeks. Initially the room was washed three times a day for 3 days and then daily thereafter. The old chill water air cooler was removed, sterilized and replaced, as was the conventional window air conditioner. Subsequent bacterial monitoring revealed a marked reduction but persistence of the same organism. Air sampling was performed with an Andersen air sampler for 10 min. These studies revealed that prior to room shut-down and intense cleaning, the bacterial concentration of the air within the operating room was approximately 10-15 culturable bacteria per cubic foot of air sampled. This is in accord with reported values of ordinary general surgery operating rooms in the cities of Philadelphia and New York. Following the cleaning process, bacterial counts had been reduced to approximately two bacteria per cubic foot of air for 3-1/2 months prior to renovation. This was achieved by good housekeeping, strict adherence to sterile technique and reduction of the number of personnel. All cultures showed persistence of the same organism.

Renovation of this 42-year-old operating room was approved by the Board of Trustees of the Barnes Hospital. Forty-seven thousand dollars were allocated which was to include all the refurbishing including the ventilation system. The monitoring system was excluded. Six weeks were permitted for reconstruction.

Figure 1 shows the operating theater as it appeared in July 1929, immediately prior to its official opening. The operating surgeon was Everts A. Graham, one of the Deans of Thoracic Surgery for many decades. The theater is basically a 24 x 26 area with a gallery along the east wall. Note the operating room light which is still in use in the Barnes Hospital in many other operating rooms. Note also the cabinet built into the wall to contain a variety of dressings and cannisters. The doorway in the middle of the picture led to a scrub room. The door on the right led to a hallway. To my knowledge there was no provision for ventilation.

Thirty years later, that is in 1959, this same operating theater had changed little (Figure 2). This is a view from the gallery section in 1959, and illustrates one of the first open-heart procedures being performed. One will note the similarity to the room illustrated in the 1929 slide.

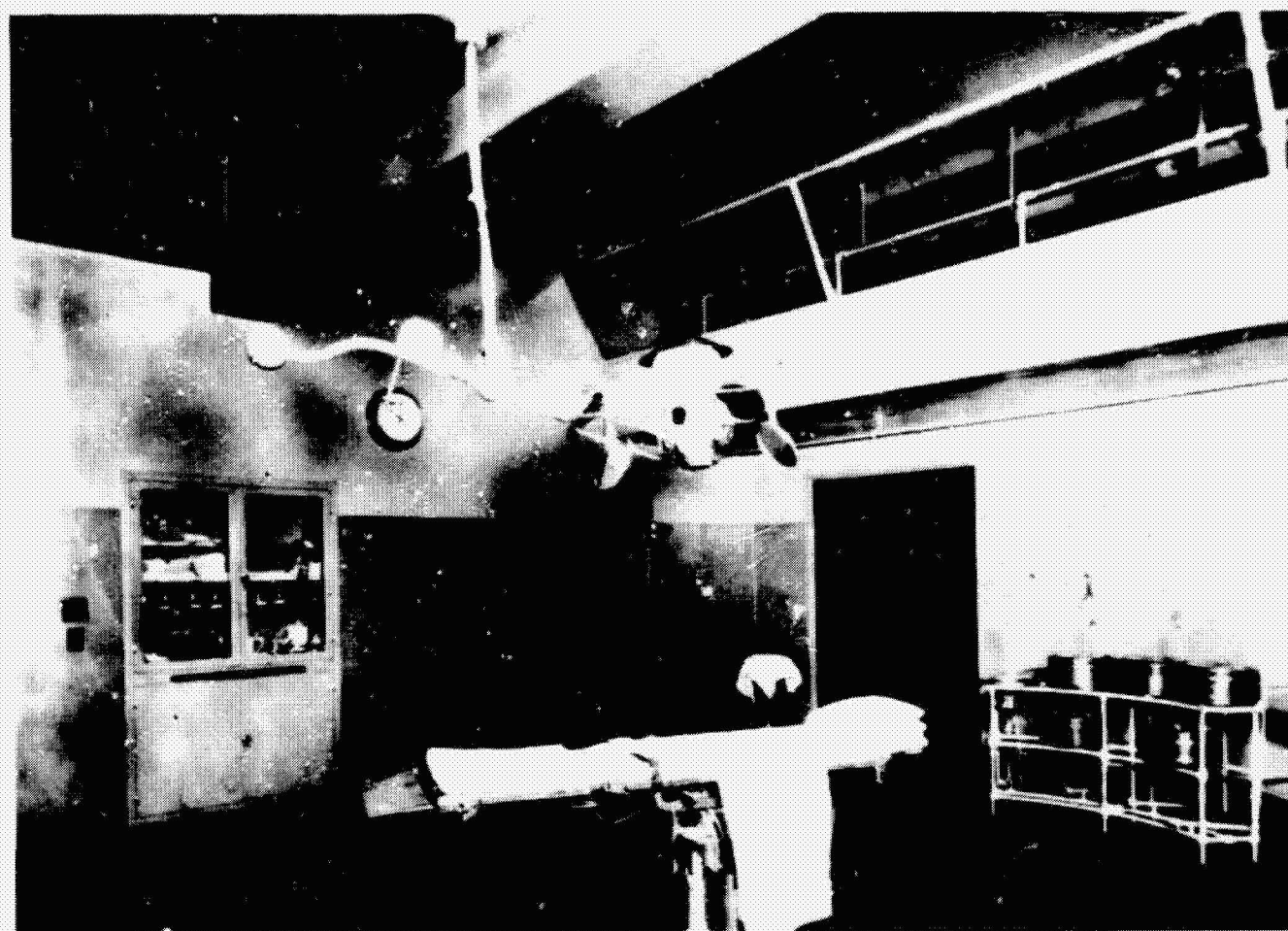

Figure 1 - Operating Theater at Barnes Hospital Complex (1929), St. Louis



Figure 2 - Operating Theater at Barnes Hospital Complex (1959)

By 1969, that is, 40 years after the room was opened, no changes had essentially occurred except for the addition of a single window air conditioner.

On September 1, 1970, following the renovation and installation of the laminar flow system, the room appeared as is illustrated in Figure 3.

The development of this laminar flow system was the result of scrutiny of available NASA/AEC data as provided by the Biomedical Applications Team from the Midwest Research Institute. Figures 4, 5, and 6 illustrate the type of general data which I show to my medical colleagues to illustrate the relationships between particle size and concentration, environmental classifications, and most importantly the relationship between airborne bacteria and the total number of particles.

A vertical versus (Figure 7) a horizontal system appeared superior for our purpose. There were three basic compromises made in the development of this system. These had to do with the method of air return, location of the HEPA filters and the volume of airflow.

The problem of air return was considered and although the optimum in a vertical installation is to have the return through a perforated floor this was not possible in this renovation because of the thick concrete slab of the present facility and the St. Louis City Code which required a permanent conductive floor. Circumferential return (Figure 8) was next considered but because of the many doorways and the few locations available for adequate ducting, the four corners were chosen. The next compromise was the matter of the position of the HEPA filter. It was quickly realized that the most desirable configuration would be to place the HEPA filter in the ceiling. The filter selected was 99.97% efficient for particles equal to and greater than 0.3μ in diameter. However, the initial and the recurring replacement costs of HEPA filters covering the 96 sq ft of perforated ceiling were considered excessive. It was, therefore, necessary to place the one large HEPA filter in the ventilation conduit and duct the air through the false plenum and through a perforated epoxied aluminum ceiling.

The third compromise involved the rate of airflow. Although 500 to 600 room changes per hour were recognized as necessary to achieve a Class 100 room with activity in a total ceiling-floor system, the cost effectiveness of this in terms of infection rates has not yet been established for surgical operating theaters. On the basis of limited work by others, it was decided that 100 room changes per hour would be sufficient. The present flow rate and lineal velocity of this system are 7,300 cubic feet per minute and 1.27 feet per second, respectively. The room is pressurized to 0.25 in. of water relative to the peripheral rooms. The system contains

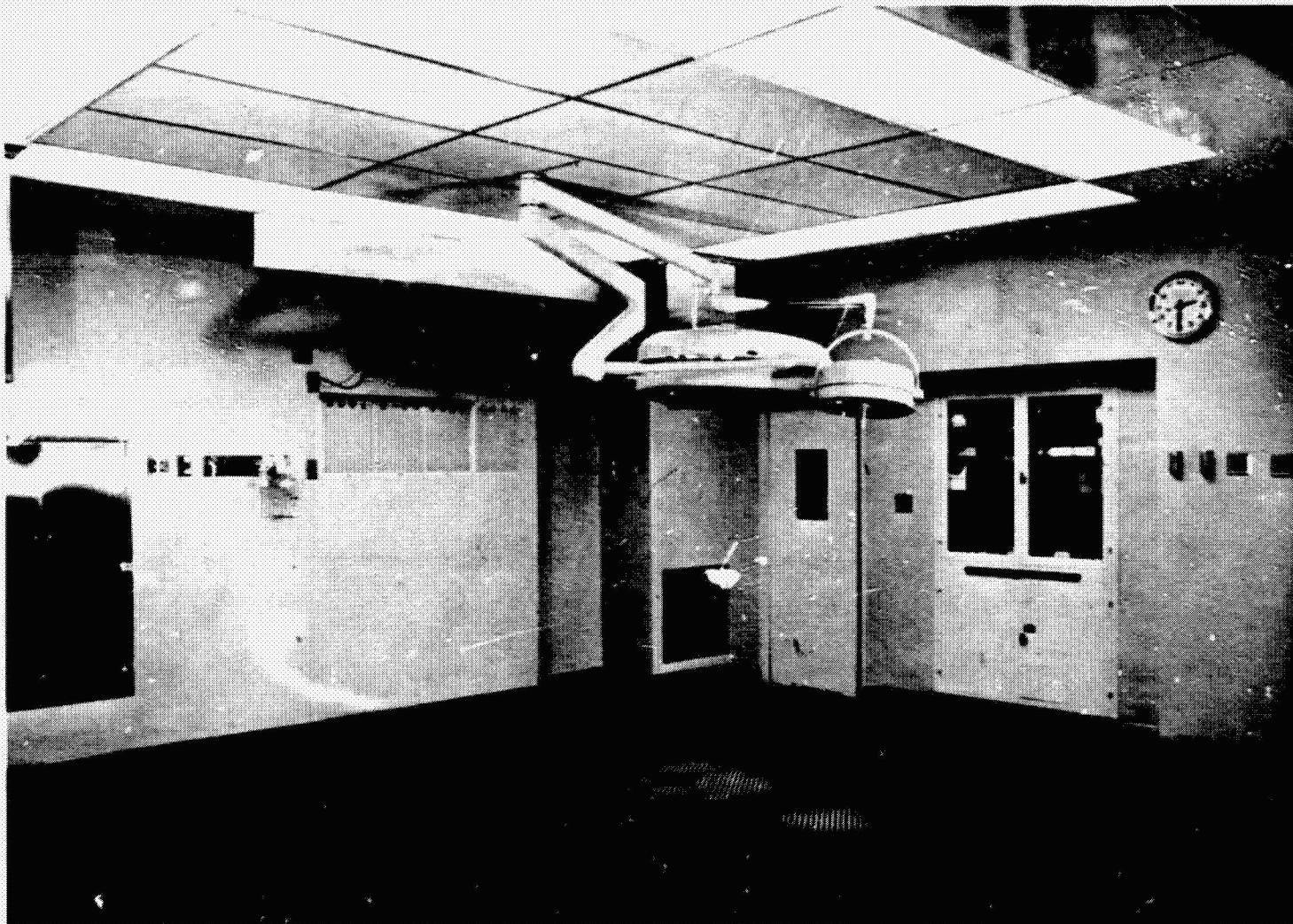

Figure 3 - Laminar Flow Installation in Operating Theater
at Barnes Hospital Complex, St. Louis

PARTICLE SIZE DISTRIBUTION CURVES CLASS 100,
 CLASS 10,000 & CLASS 100,000 ARE BASED ON
 FEDERAL STANDARD, NUMBER 209.

AIR FORCE STANDARDS ARE BASED ON 1 JULY 1963
 ISSUE OF T. O. 00-25-203.

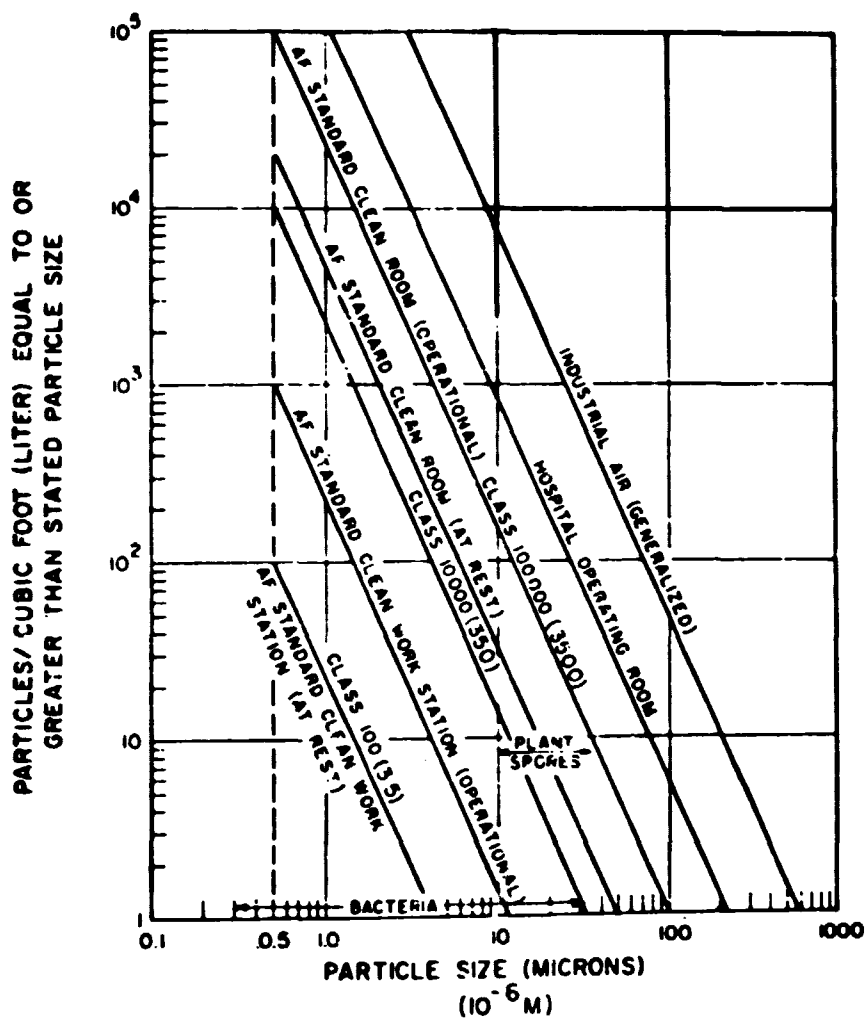

Figure 4 - Comparison Among Classes of Clean Rooms
 and Clean Work Stations

Class English System Metric System	Maximum Number of Particles per Cu. Ft. 0.5 micron and Larger per liter	Maximum Number of Particles per Cu. Ft. 5 microns and Larger per liter	Maximum Number of Viable Particles per Cu. Ft. per liter	Average Number of Viable Particles per Sq. Ft. per Week per M ² per week
100	100	1	0.1	1,200
3.5	3.5	0.035	0.0035	12,900
10,000	10,000	65	0.5	6,000
350	350	2.3	0.0176	64,600
100,000	100,000	700	2.5	30,000
3,500	3,500	25	0.0884	323,000

Figure 5 - Air Cleanliness Classes

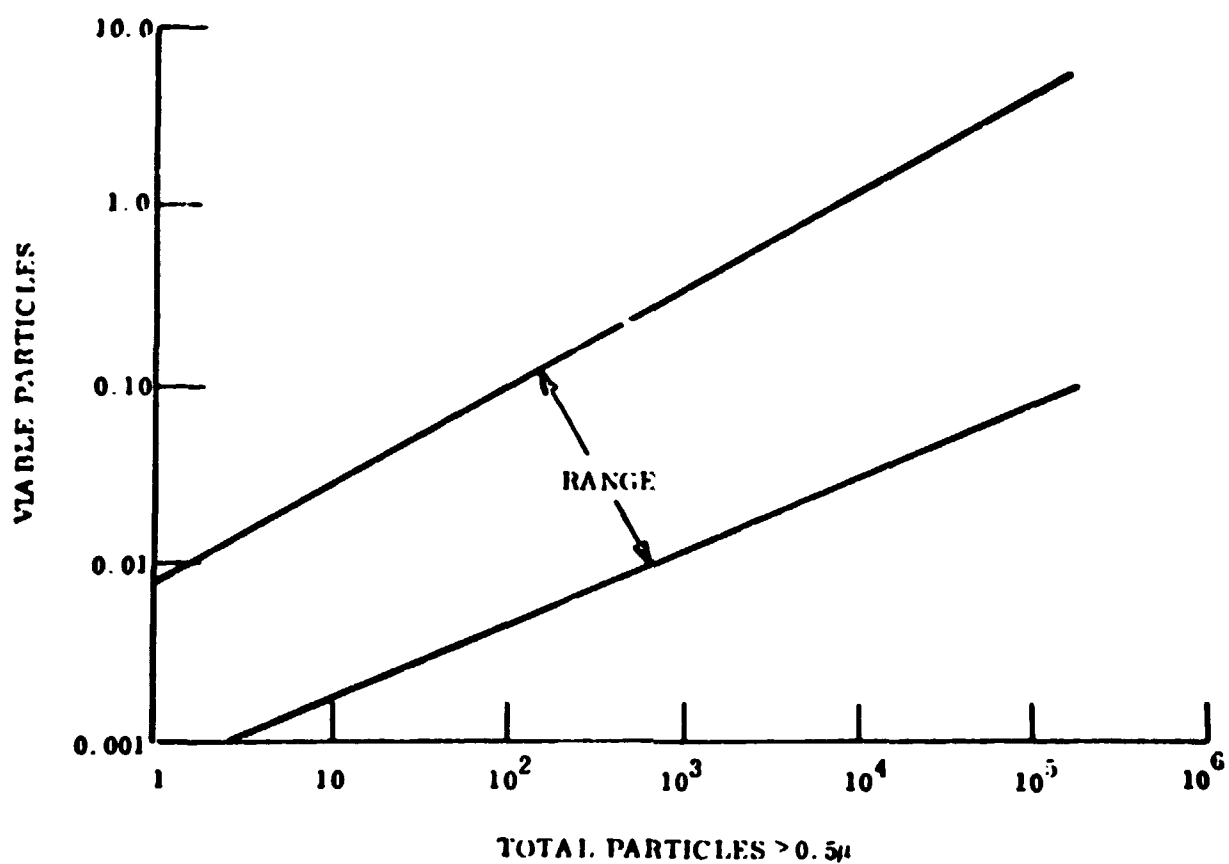

Figure 6 - Relationship Between Particulate and Microbial Contamination Per Cubic Foot of Clean Air

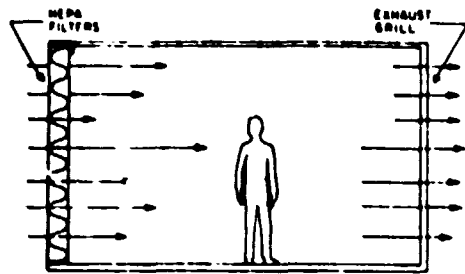

FIGURE A. LAMINAR FLOW TYPE CLEAN ROOM (AIR FLOW FROM WALL TO WALL)

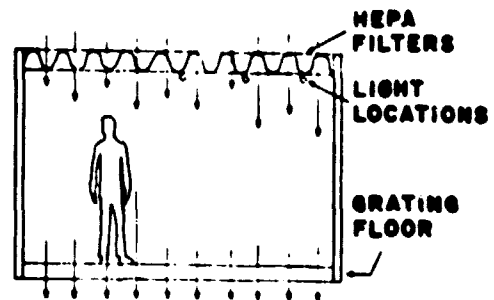

FIGURE B. LAMINAR FLOW TYPE CLEAN ROOM (AIR FLOW FROM CEILING TO FLOOR)

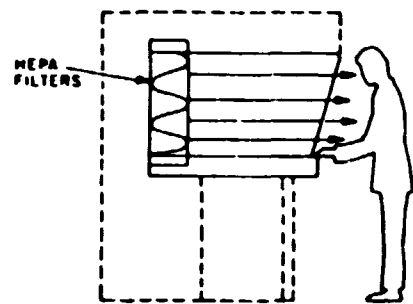

FIGURE C. LAMINAR FLOW TYPE CLEAN WORK STATION

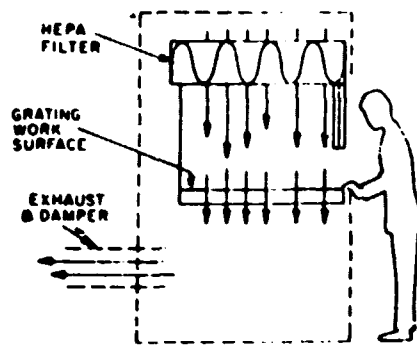

FIGURE D. LAMINAR FLOW TYPE CLEAN WORK STATION

Figure 7 - Laminar Flow Clean Rooms and Work Stations

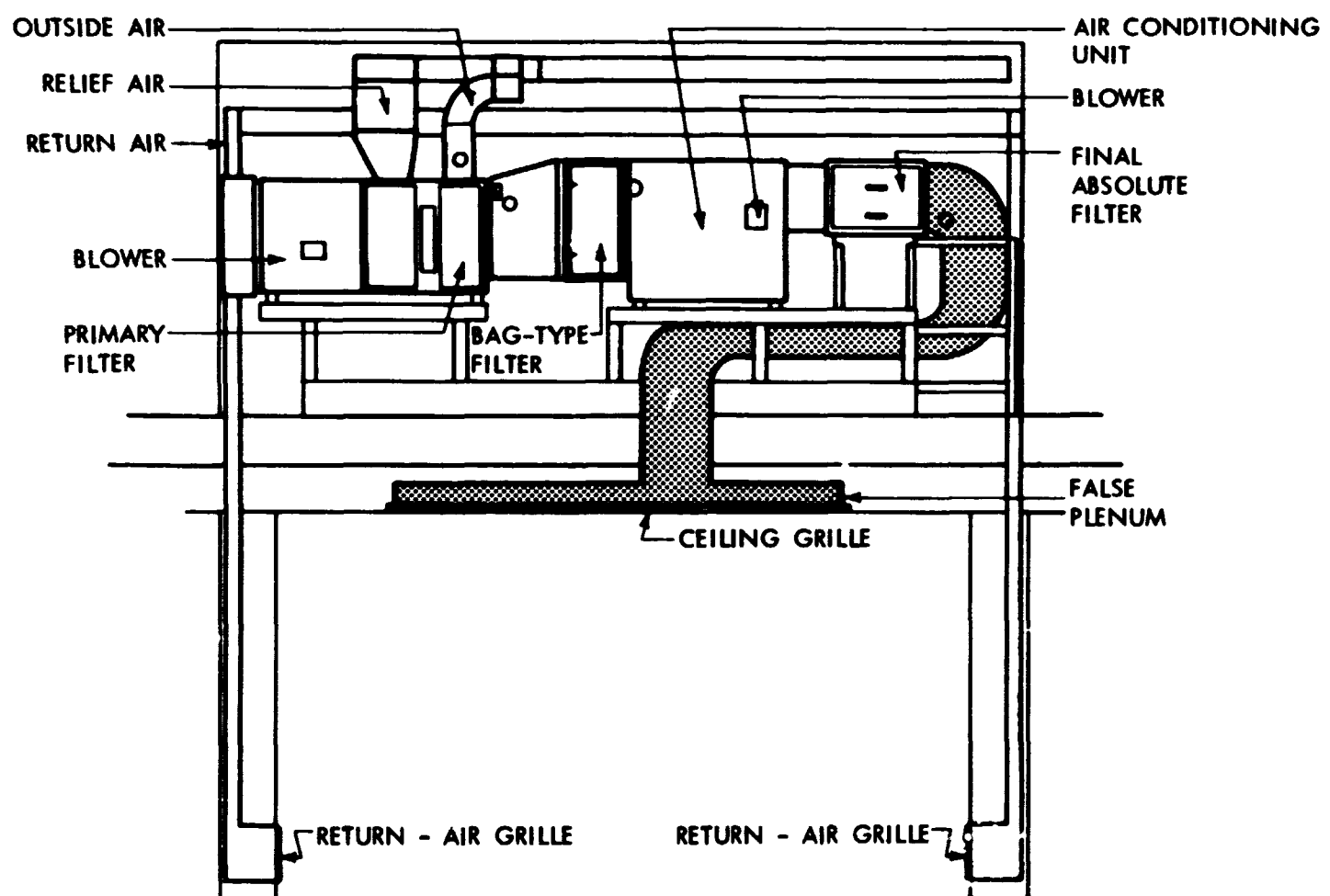

Figure 8 - Schematic Side View of Clean Air System

three stages of disposal filters with efficiencies of 30% to 5 μ , 95% greater than 3 μ and 99.97% greater than 0.3 μ . The temperature and humidity are closely controlled to $70 \pm 0.5^\circ\text{F}$ and $55\% \pm 1\%$, respectively.

Figure 9 is a view of the air handling system in the old gallery. Figure 10 shows a schematic of the surgery suite layout. The results of this effort were surprisingly good. The first thing that was noted by all personnel was the uniform comfort throughout the room. Although the noise level was 53 db at 100 room changes an hour, it was constant and acted as a muffler for sharp noises of instruments hitting the floor or metallic surfaces. No breeze was felt by the operating team. Sweating was minimized. One was able to operate in the room for many hours with less fatigue than previously.

After renovation two parallel studies were conducted. First, a particle counting system was utilized to sample total particles in various places in the room and during each case. The instrument utilized was a Coulter Counter, model 130, with a fractional count range of 0.5-0.1 μ , 1.0 - 5.0 μ , 5.0 - 10.0 μ and greater than 10 μ .

Figure 11 shows the Coulter Counter we used to make our particle counts. This instrument was not available to us prior to renovation so no data are available for comparison here. The instrument was made available to us by the manufacturer's representative and for an extended period of time by the Midwest Research Institute.

Figure 12 gives the average counts and the ranges at 100 room changes per hour. During surgical activity from 8:00 A.M. to 4:00 P.M., based on 256 sampling periods, there was a range of particles from 1,470 - 14,850 particles per cubic foot with a mean value of 9,600 total particles per cubic foot. Note that this is in marked contrast to the peripheral areas of this same surgical suite which include the anesthesia induction room, the sterilizer and heart-lung machine room, the monitor room, and the service hallways. Note that the particle counts in these areas ranged from 50,000-400,000 particles per cubic foot of air.

Data were obtained from other operating rooms in the surgical suite of the Barnes Hospital. Although this information is preliminary and requires much more sampling to be authoritative and statistically significant, the other operating rooms had a range of 11,000-150,000 particles per cubic foot.

The second part of the study was bacterial sampling. This has been performed for 3-1/2 months prior to renovation and has been carried out continuously since renovation at both 25 and 100 room changes per hour.

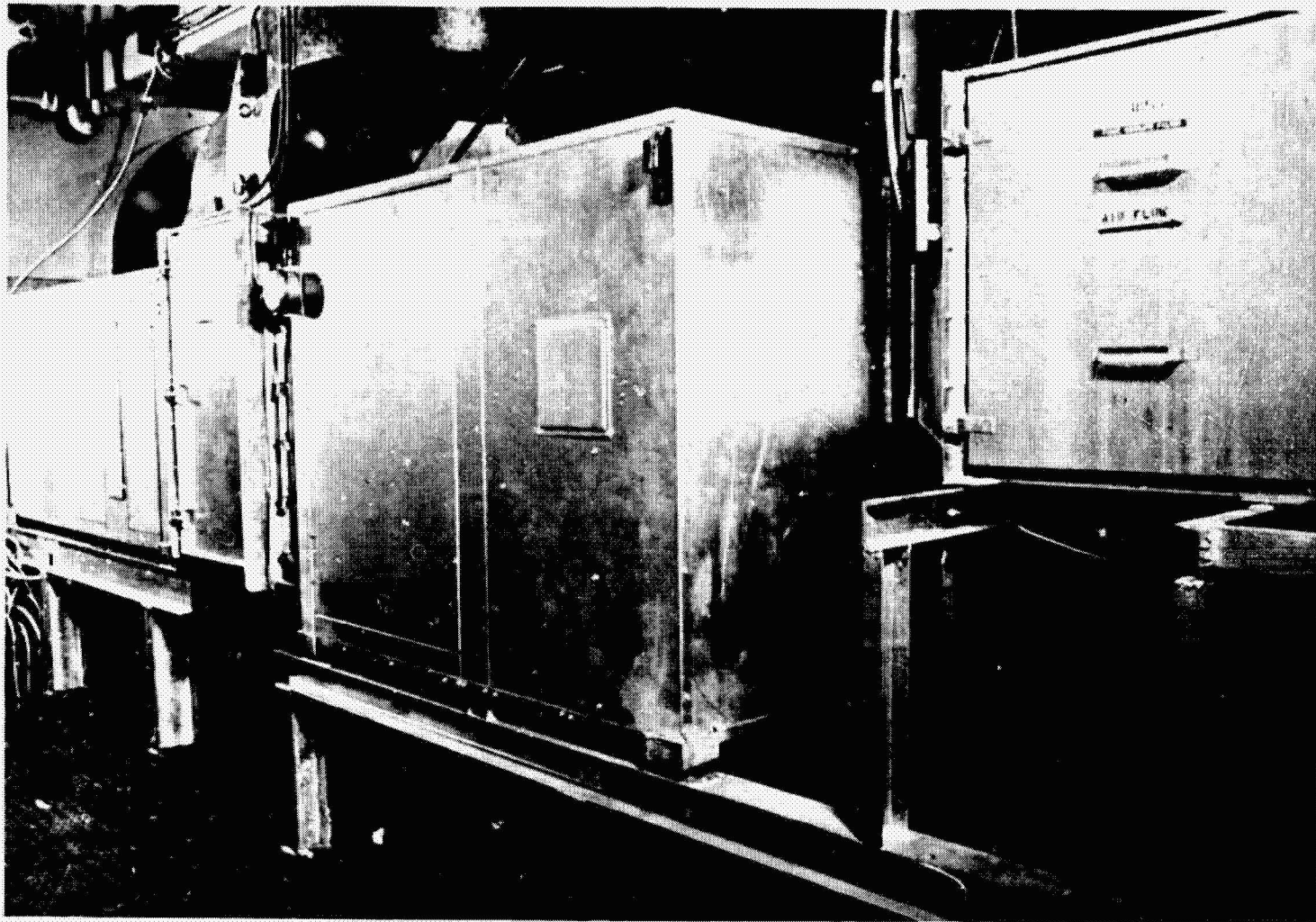

Figure 9 - Ventilation System Located in Previous Viewing Gallery

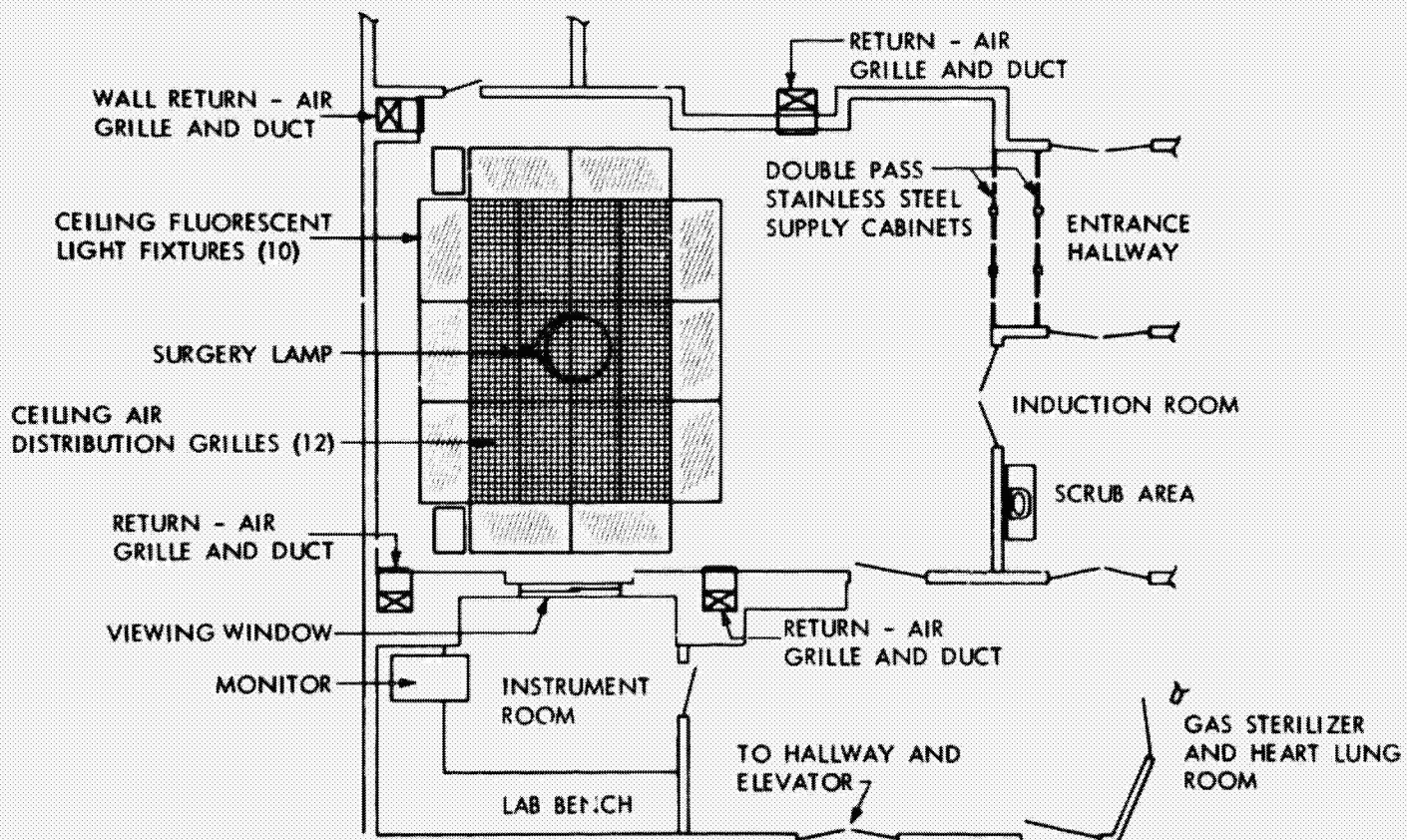

Figure 10 - Floor Plan for Cardiothoracic Surgical Suite, Barnes Hospital Complex

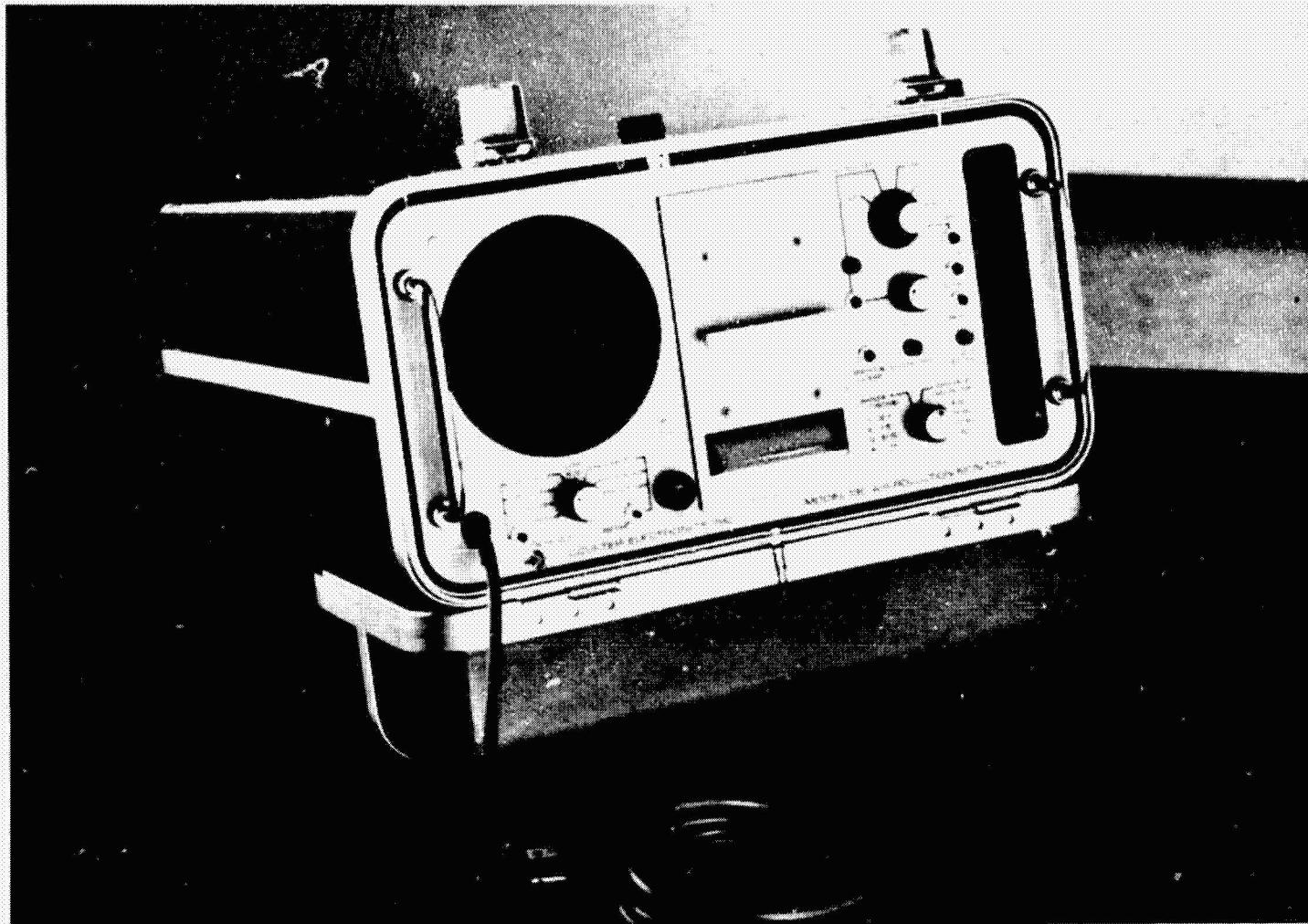

Figure 11 - Coulter Particle Counter

<u>LOCATION</u>	<u>TIME</u>	<u>PARTICLES PER CUBIC FOOT AIR</u>	
		<u>RANGE</u>	<u>MEAN</u>
Cardiac O.R. (100 Rm.Ch./Hr.)	8:00 AM - 4:00 PM	1,470-14,850	9,600
	12:00 PM - 8:00 AM	116- 3,790	1,720
General Surgery Operating Rooms (4)	8:00 AM - 2:00 PM	11,000-152,000	67,100
Cardiac Induction	8:00 AM - 4:00 PM	30,000-120,000	45,200
O.R. Hallway	8:00 AM - 4:00 PM	33,700-340,000	83,200

Figure 12 - Total Airborne Particle Analysis

Figure 13 shows the bacterial sampling data. Six blood agar plates were used in the Anderson air sampler. Each run was 10 min. Three samples were obtained per case. The first sample was obtained immediately after completion of the median sternotomy, a standard incision for most procedures. The second sample was at the initiation of cardiopulmonary bypass. The third sample was taken at the cessation of cardiopulmonary bypass. The first period was chosen, that is, after completion of the incision because this represented a time when the operative team was settled down and there was little movement in the operating room except for that of the circulating nurses. The time frame of cardiopulmonary bypass represented the maximal period of time that a prosthesis would be exposed to airborne bacteria in the operating field. All prosthetic material and prosthetic valves were maintained in their closed containers prior to use by the surgeon. Thus, there was no possibility of contamination from the air while lying on a back table.

Results shown here illustrate the fact that following cleaning of the room we had an exceptionally low number of bacteria per cubic foot prior to renovation. This simply illustrates what compulsive house cleaning can do in an operating theater in which there were essentially no room changes per hour. Following renovation, the ventilation system was initially set at 25 room changes per hour. One will notice here that the bacterial concentrations as measured for 13 cases were 2.24 ± 1.27 bacteria per cubic foot. There was no statistical significance between pre- and post-renovation values at 25 room changes per hour. However, at 100 room changes per hour 27 cases were monitored and the bacterial concentration was found to be reduced to 0.88 ± 0.64 bacteria per cubic foot. This is statistically significant compared to either the prer renovation value or the value at 25 room changes an hour at a p value of less than 0.01.

In summary, the purpose of the installation of the laminar flow system was to add a protective adjunct as an aid toward the prevention of prosthetic material infections. This laminar flow system has yielded high flow ventilation, superior cleanliness, excellent thermal, humidity and noise characteristics in a 42-year-old operating theater. The cost was \$8,000 for the commercially available components and 2,304 labor hours by in-house personnel. This includes all the electrician, plumbing, metal work, and engineering time.

During the first 6 months after renovation, there were 159 consecutive operations performed in this operating theater. To date there have been no known acquired prosthetic material infections, and but one superficial wound infection in a groin incision. We realize, of course, that a great deal more experience must be gained and a great deal more data analysis performed over the ensuing years to be able to make a statistically firm statement concerning the effect of this ventilation system on both wound and prosthetic material infections. However, we are greatly encouraged by early preliminary data.

Thank you.

<u>No. Bacteria Per Cubic Foot Air</u>					
<u>Condition</u>	<u>No. Cases</u>	<u>No. Plates</u>	<u>Mean</u>	<u>Std.Dev.</u>	<u>Std. Error of Mean</u>
Prerenovation	25	444	1.98	±1.66	±0.17
Post renovation 25 Room Ch./Hr.	13	216	2.24	±1.27	±0.19
100 Room Ch./Hr.	27	456	0.88	±0.64	±0.07

Figure 13 - Airborne Bacterial Analysis

Mr. S: hi:

This is our last session for today, and we will have one more paper on an experience with a wall-less horizontal flow clean air system. This paper will be given by Dr. Carl L. Nelson, who received his degree in medicine from Indiana University, served his internship in Los Angeles, took his orthopedic training at the Cleveland Clinic in Cleveland, Ohio. He took a year of special training at the Nuffield Orthopaedic Center at the University of Oxford in England; he is now a member of the staff at the Cleveland Clinic, and his title is Associate Professor of Orthopedic Surgery. He has had only a couple of weeks to get this paper ready; it was a last-minute type affair, and we do apologize for putting him on a spot like this. I guess, probably, if he had it all to do over again, right now he would have said, "Hell, no," but we are very happy to have you, Dr. Nelson, and we appreciate your efforts in the very short preparation time period we gave you.

Dr. Carl L. Nelson.

**EXPERIENCE WITH A WALL-LESS HORIZONTAL
CLEAN AIR SYSTEM DURING TOTAL HIP REPLACEMENT**

**Carl L. Nelson, M.D.
The Cleveland Clinic Foundation
Cleveland, Ohio**

Dr. Nelson:

Mr. Chairman, ladies and gentlemen, 2 weeks ago Dr. Castles phoned and asked me to speak about the clean air system. I said I would have difficulty presenting scientific data at such short notice, but I would be glad to come. He said, "don't worry, just tell us what you are doing and what you have done." I would not accuse Dr. Castles of misrepresentation, but more of salesmanship. I am reminded of the aphorism that the difference between rape and rapture is salesmanship.

Clean air is of common interest and it has stimulated the ecologist, the scientist, and now the surgeon to look into the concept. Needless to say anyone who has been to Cleveland recently can appreciate my concern with clean air in the city as well as in the surgical suite. Clean air implies unclean air, and as we have seen today, there certainly is unclean air. There is also an emotional connotation that is attached to it, it seems, as much as is attached to motherhood and the flag. One must separate fact from hypothesis and attribute to the clean air system only those things we are sure of. If unproven features are dogmatically attributed to this system, it will detract from what appears to be a logical, useful and beneficial adjunct in combating infection. It is our responsibility as well as that of the manufacturer and the engineer, to evaluate the system, clearly define its practical use and characterize its proven scientific merit.

At a meeting such as this, it is hoped that a more standard method of evaluation will evolve, and we can better determine exactly what each of us is measuring, and then compare accurately. The problems that are faced in any evaluation system are the standardization of data and the standardization of controls.

To the engineer clean air technology eliminates contamination, and the failure of the clean air system is a failure to eliminate contamination which produces failure of the mission. To the surgeon, failure of the clean air system produces infection and this is a failure of our mission. All surgeons dread infection and there are certain specialty groups to whom infection is of more significant consequence. The orthopaedic surgeon deals with bones and joints and has a special concern because of the propensity of bone to become infected, and then to retain infection.

Advances in treating diseases of the hip by the total hip replacement arthroplasty have been the stimulus for again trying to reduce infection rate. Why has this one operative procedure led to the utilization of the clean air system? One of the most significant reasons is that the development of a serious deep infection in the total hip replacement prosthesis usually produces a total failure. Because of the fear of such a deep hip infection developing, more emphasis has been placed on eradicating infection. This is better understood if one can realize that this operation usually gives quite good results, but with an infection, total failure usually is incurred.

The other significant feature about the total hip replacement arthroplasty is that it is one of the most sensitive indicators of wound infection, and is probably more sensitive than any other previously used operative procedure in orthopaedic surgery. This one orthopaedic procedure, in fact, may be a more sensitive indicator of infection than most commonly used laboratory bacterial testing systems. The reason that the procedure is such a sensitive indicator is that there is a great deal of dead space in the area, and secondarily there is no living tissue in contact with the prosthesis to combat infection. This one procedure is a delicate indicator of infection and from it one may be able to determine significant statistical data confirming the effectiveness of the different types of clean air systems.

In discussing the clean air system, the historical background of infections and attempts to eradicate infections should be reviewed. What is an infection? By definition an infection is "An invasion of the body by pathogenic microorganisms and the reaction of the tissue to their presence, and to the toxins generated by them, often applied to the presence of microorganisms within tissue, whether or not this results in detectable pathological effects;" the last part of the definition is the key. If an infection is deep and serious, the results are obvious. "Lesser infections" or contamination on a bacterial basis produces heated discussions in an attempt to define it. The lesser wound infections causing redness, swelling and fever, although not clinically significant, are bacteriologically important. Therefore, in reviewing and comparing statistics, one must be sure to define exactly what we are speaking of, and the emphasis here is just made for that one purpose: careful comparison. It is also axiomatic that the number of infections recorded in the hospital will vary directly with the diligence with which they are sought out and reported; also the number of minor infections will vary according to the impression of the observer.

Infection is not a recent problem in surgery. In 1880 Moynihan stated that two-thirds of his patients died of infection after he opened the belly. In 1895, Brewer showed that clean operations were followed by a 39% infection rate. Lister then proposed the concept of antiseptic technique and through the application of this concept, the infection rate decreased. This concept led to the era of aseptic surgery in which preoperative skin cleansing was combined with sterile scrub for the surgeon, rubber gloves, masks, sterile drapes, sterile clothing and gowns, sterile instruments, adequate housekeeping and sterilization. In orthopaedics, there developed a procedure called the no-touch technique, as well. Instruments were placed so that only the handles could be touched by the hands of the surgeon and only the working portion of the instrument touched the patient. How effective have these procedures been in the past, and what can we expect from them now? The first principle that one must concede in discussing infection is that there is no substitute for strict adherence to standard aseptic surgical techniques. Meleny, in 1933, reported that by carefully following

aseptic techniques and rigidly enforcing movement in the operating room, by carefully preparing the patients and being gentle with the tissues, he reduced the serious wound infection rate from 4 to 1.7% and minor wound infections from 10 to 5%. McKissick reduced the surgical infection rate from 15.1 to 1.1% by the introduction of more rigid aseptic techniques. Henderson, in 1961, reviewing 3,290 operations, showed that the serious infection rate could be kept to 1.7%, and Steele, in 1966, in doing one of the most thorough pieces of detective work in the field of wound infection, reduced their infection rate from 5 to 0.58%.

All had similar criteria for a decreased infection rate: (1) rigid enforcement of movement in the operating room, (2) careful preparation of the patient, (3) gentleness of tissue handling, and (4) making everyone in the hospital acutely aware of the problem of infection. It must be emphasized that if one new adjunct is added to reduce infection, and at the same time one begins to enforce rigidly aseptic techniques, then a decrease in infection cannot be attributed alone to one new adjunct. One must be careful when many things are changed not to attribute improvement to one change alone. Even with the most rigid enforcement techniques, there continues to be a significant infection rate, and the search for methods to reduce this rate continues.

From where does the bacterial contamination come that causes infection? Almost everyone agrees that infection occurs at the time of surgery. There is less agreement as to whether the infection of bacterial contamination is exogenous or endogenous. A single human will shed from 3,000 to 50,000 organisms per minute, depending on how recently he has showered and on the type of clothing that he is wearing. Blowers have also shown that surgeons, by movement of their arms and legs, will pump bacteria into the wound. There is no question that if one releases particles with attached bacteria above the wound, they will be deposited into the wound; even the most staunch non-believer of airborne contamination can agree with the concept that bacteria should not be deposited into an open wound.

In light of this knowledge what attempts have been made in the past to eradicate infection, and how does it effect our present attempts with the clean air system? In the era of introduction of antibiotics into medicine, prophylactic antibiotics were used in an effort to reduce infections. In reviewing statistics on prophylactic antibiotics, almost all studies were made postoperatively. Stinchfield's study in which antibiotics were given at the time of surgery shows the decrease in the wound infections. It is probably not justified to say that antibiotics will not reduce the infection rate. This points out that an attempt to reduce infection rate must be done scientifically, carefully, and with clear thinking to avoid this type of apparent misinterpretation of data.

Ultraviolet light also has been used in an attempt to reduce the infection rate by reducing the amount of airborne bacteria. What have been the results of the use of ultraviolet light? There is no question that ultraviolet light decreased the amount of bacterial contamination in the operating room, but by using a double blind study with dummy lamps in one room, it was shown that the infection route was almost identical whether there was ultraviolet light on or not. By removing bacteria from the air, it has been shown in this instance that it has not made a significant difference in the infection rate. Therefore, in looking at data one must be careful not to state what is logical, but what is factual.

With these two somewhat negative studies in the past and other poor attempts at reducing infection, is there any justification for further study, and is there any justification for believing that the clean air system is of value? Altemeier^{1/} quotes the estimated statistics for 1967. Approximately 31,600,000 people were admitted to hospitals of whom 18,000,000 underwent surgical procedures. It is estimated that 7.4% or 1,300,000 of these people became infected. It was further calculated that wound infections cost on an average of \$7,000. If you take 7,000 times 1.4 million you come up with the staggering figure of over 9 billion dollars for wound infection. Although this is a significant monetary figure, only the individual and the surgeon can truly understand the suffering, the disability, and the deformity that occur with infection. With an average estimate of \$7,000 per wound infection, there is no question that this alone by monetary standards justifies any rational attempt to reduce wound infection.

There are also other studies available, such as that by Fox^{2,3/} which have shown a significant decrease in the number of organisms collected at the wound site in a clean air system. His studies showed an almost ten-fold decrease in bacterial contamination at the wound site in comparison to that in a room with a laminar airflow system on, and one with it off.

We know then that there can be a decrease in bacterial contamination by the use of a clean air system. Is there any practical proof that it will decrease infection rate? Charnley's statistics have shown that with increased flow he reduced the infection rate from 8.9 to 1.3%. There is no

^{1/} Altemeier, W. A., Levenson, S.: Trauma Workshop. Report: Infection, immunology, gnopobiosis. J. of Trauma, 10: 1084-1086.

^{2/} Fox, D.G., and Maitland, B.: Contamination levels in a laminar flow operating room. J. Amer. Med. Assoc. 42: 108-112, June 1968.

^{3/} Fox, D.G.: A study of the application of laminar flow ventilation to operating rooms. Public Health Monograph No. 78 (PHS Publication No. 1894) U.S. Government Printing Office, Washington D.C., 1969.

question that during this period he also changed his technique, changed his criteria for operation, improved his technique and more rigidly enforced aseptic technique. However, this is a significant drop and combined with the other data we know, certainly influences all of us to consider the clean air system as a valuable adjunct in reducing hospital infections. It appears that just as medicine has accepted the sterilization of instruments as a means of preventing transmission of infection, it is to be expected that there will be widespread acceptance of means to control airborne infections as well. In a large clinical teaching institution where there is a great deal of care by residents, anesthetists, and visitors, there must be an effort made to reduce the amount of airborne infection. Consequently, this led us to adopt a horizontal wall-less airflow clean air system as an adjunct in an attempt to reduce the infection rate. We then looked at the clean air systems on four points: efficiency, versatility, ease of installation and economy.

The clean air system we selected is a wall-less horizontal model consisting of two parts: a self-contained blower filter system projecting a horizontal laminar flow of Class-100 air, and a vacuum aspirator system for the surgeon. The blower module placed at one end of the operating theater propels a flow of clean air across the room. On each lateral edge of the module is a projector vane. This is an engineering device which eradicates backflow around the edge and projects a flow of clean air outward; it produces a curtain of air over the wound site itself.

In a standard operating theater air change is a form of dilution, in which both air and particles flow through the room evenly and are diluted into the system. With this type of system the air enters the ceiling, is diluted and passes out through the lower portion.

The horizontal laminar flow system sends airflow in one direction. In this manner, particles are removed from the worksite of the operating area. This system produces 200 changes per hr in the room in comparison to the standard operating room which has approximately 12 changes. These 200 changes are for the entire room. During the process, however, there are 549 changes per hr directly over the work area. The air produced is likened to a piston of air that is forced across the room sweeping those particles, shed by the surgeon and the staff, away from them and across the room. The air then strikes the opposite wall, turns, returns laterally, flows along the wall and enters the system at its side. The high efficiency particulate air filter lies within the front part of the machine behind the perforated metal cover. The filter needs to be checked periodically and changed approximately every 2 to 5 years. It is made of fiber glass and is 99.97% effective in removing particulate matter and attached bacteria and viruses. A pre-filter area on the lateral side also has a filter, which must be removed, washed and replaced monthly. The suction apparatus attaches

to the surgeon's mask next to his cheek, and then attaches to the manifold. The manifold attaches to the machine itself and the purpose of this apparatus is to vacuum away particulate matter from the mouth area.

This apparatus can be installed easily and quickly. It does not interfere with the lighting system and x-rays can be taken with ease. The use of x-ray in the total hip replacement arthroplasty is unusual. However, in one instance, x-rays were necessary for a case of "marble bone disease" (osteopetrosis). It was necessary and its use was easily facilitated by the system.

To emphasize the other things we do, we also use prophylactic antibiotics; we give a therapeutic prophylactic dose of antibiotics to the patient the night before, during and after surgery. We treat for one specific organism; Staphylococcus aureus, and we use Oxycillin. Secondly, all patients are carefully prepared for surgery. We use the double glove technique, as we and many others have found one pair of gloves rip rather easily. Outside the operating theater we have this gentle reminder--"Do Not Enter This Room."

The following, Figures 1 and 2, demonstrate the magnitude of the exposure for the total hip replacement arthroplasty. The types of instruments used in this procedure certainly produce great air turbulence and the activity of the surgeon is significant. Because of this activity questions are sometimes asked regarding the use of the mask and the suction tubing. We find that the suction apparatus attached to the manifold has a pleasant and cooling effect and is not an impediment to the surgeon. Occasionally there is some irritation from the apparatus at the cheek, and also a twisting can occur. I think, however, there will be significant advances in the engineering of this apparatus in the near future.

What has been our impression in using it? First of all, we feel the use of this system is logical, economically feasible and effective. I do not have statistically significant data to present to you today, but our platelet count directly in front of the module has shown that the air is essentially sterile. That is, there is a definite production of Class-100 air. Over the wound site we have a significant drop in bacterial contamination compared with the non-clean air rooms. There is a significant increase of bacterial count in the area of anesthesia and we interpret this as flow of particulate matter into this area. The system described is versatile. We have not had to adjust our lighting system, we have only minimally changed the air conditioning system, and there is very little noise. One can speak normally with the system in operation, and noise produced by the module is not disturbing. The system is safe and is used as an adjunct to reduce infection. The maintenance and care for this apparatus is adequate and the overall cost for the apparatus is less than \$10,000.

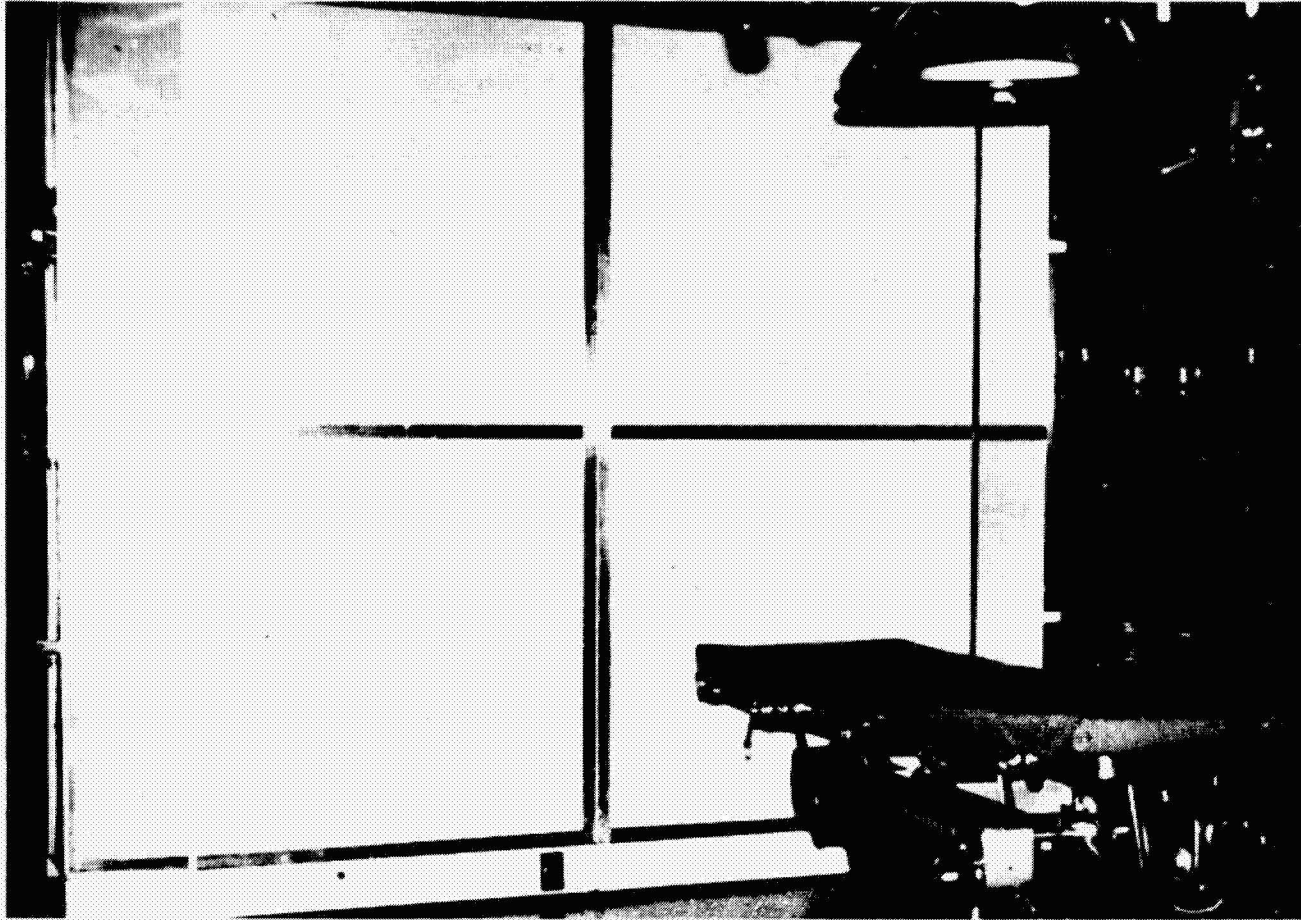

Figure 1 - Laminar Flow System Used at Cleveland Clinic, Cleveland



Figure 2 - View of Wound Size During Total Hip Replacement

What is our overall result and what does it mean? Presently, we do not have anyone who wishes to do half of his cases in the nonlaminar airflow system and the other in a laminar airflow system. Also getting surgeons to discuss their infection rate has been likened to discussing chastity with a group of young ladies. There may be those who have had the experience that is valuable to know, but it is difficult to get an unemotional accurate evaluation. In over 350 Charnley-Müller total hip replacement arthroplasties, we have had no immediate wound infection. We have had two which occurred some time after the procedure, both with extenuating circumstances; one patient who had pneumonia, was receiving Cortisone, and then developed hip pain; and the other patient had a secondary wound at the hip.

Our impression has been that this apparatus is a valuable adjunct. We have no scientific data to prove that it reduces infection, but the concept is logical and this type of apparatus operates efficiently and effectively.

Mr. Sivinski:

Our next speaker as listed on the schedule, Dr. Amstutz, will not be here today. He will be here tomorrow for the panel, but he just could not get back from Spain in time to make it today. Instead, one of his co-workers will be presenting a paper which has a little bit different title; it is called, "Improving the Environment of the Operating Room." This is a summary paper, by Dr. Harry Buchberg from UCLA. He is Professor of Engineering and Applied Science at UCLA; he is a registered professional engineer in the state of California; in 1970 he was appointed chairman of a Steering Committee on Bioengineering at the School of Engineering and Applied Science. I visited there last year, and they have a very good program going between the medical school and the engineering school which I think is a model program that many more schools ought to copy. He is chairing that particular committee now; he was a member from 1966 to 1969 on the Committee on Basic Research of the National Research Council of the National Academy of Science, and has numerous other papers and publications which he has done in the area of environmental control problems.

"Improving the Environment of the Operating Room"--Harry Buchberg.

IMPROVING THE AIR ENVIRONMENT OF THE OPERATING ROOM

Harry Buchberg, Professor
Energy and Kinetics Department
School of Engineering and Applied Science
University of California
Los Angeles, California

Professor Buchberg:

Mr. Chairman, ladies and gentlemen, it is a real privilege to have been invited to review with you methods for improving the air environment of the operating room.

I would also like to express my regrets that Dr. Amstutz was not able to come today. He has been detained in Chicago attending an Executive Committee meeting of the Academy of Orthopedic Surgeons. He has consented to make his remarks prior to the Forum tomorrow morning.

It is particularly difficult to be the last speaker after so many fine presentations and I know that I am going to repeat many things that other people have already said; this is inevitable. I thought it might be useful in my presentation to simply state the problem of the air environment in operating rooms and then to describe the various improvements that have been proposed, tried and in some cases analyzed. Finally, a discussion of methods for the evaluation of the effectiveness and the optimum utilization of these systems might be useful.

The present concern with the operating room environment stems from a desire to reduce the number of post-operative infections. There appears to be ample evidence recorded by Howe^{1/} in 1958; Blowers, et al.,^{2/} in 1960; Greene, et al.,^{3/} in 1962; Burke^{4/} in 1963; Fraser^{5/} in 1963;

^{1/} Howe, C. W., "Staphylococcal Disease on Surgical Services," Proceedings of National Conference on Hospital-Acquired Staphylococcal Disease (1958), p. 75.

^{2/} Blowers, R., and B. Crew, "Ventilation of Operating Theaters," J. of Hygiene, Cambridge, Vol. 58, No. 427 (1960), pp. 427-448. Blowers, R., and D. K. Wallace, "Ventilation of Operating Rooms-Bacteriological Investigations," American Journal of Public Health, Vol. 50, No. 4 (April 1960), pp. 484-490.

^{3/} Greene, V. W., D. Vesley, R. G. Bond, and G. S. Michaelson, "Microbiological Contamination of Hospital Air," Applied Microbiology, Vol. 10 (1962), pp. 188-189.

^{4/} Burke, J. F., "Identification of the Sources of Staphylococci Contaminating the Surgical Wound During Operation," Ann. Surg., Vol. 158 (1963), pp. 898-904.

^{5/} Fraser, David A., "Evaluation of the Performance of Ventilation Systems," Final Report under Contract PH-43-63-503, Environmental Sciences Branch, Division of Research Services, National Institutes of Health, Bethesda, Maryland (August 29, 1963).

Nahmias, et al.,^{1/} in 1960; Walter, et al.,^{2/} in 1963; Whitcomb, et al.,^{3/} in 1965; Charnley, et al.,^{4/} in 1969; and Dr. Ulrich this morning and previously, that viable airborne particles, i.e., droplet nuclei and dust-carrying bacterial organisms in the 1 to 20 μ range may account for a significant number of infections. There seems to be little doubt that potentially pathogenic organisms can be and are transported by the air environment. The exact route of entry to a surgical patient is very seldom known; sedimentation on items that eventually contact the patient or sedimentation directly on the wound site are possible routes. From a quantitative standpoint there is still considerable skepticism among some physicians and life scientists as to the significance of the air environment in post-operative infections when adequate acceptable aseptic procedures are followed in the surgery. I am not in a position to comment authoritatively on this issue. It appears clear that additional research is needed to pinpoint the role of the air environment in the infection process. Definitive animal experiments could be useful in dealing with the problem.

Viable particles found in the air environment of the surgery may be brought in through infiltration and ventilation, and may be the result of sources within the space, primarily people and objects brought in. It is well known that actual particle counts are very sensitive to personnel activity in the space, rising sharply during periods of high activity and dropping to low levels when activity ceases. Studies have indicated that from 1,500 to 50,000 viable particles per minute may be shed from personnel, depending upon the individual, upon the degree of activity, and the type of gowning.

The requirements for a nearly sterile environment in the operating room are: a sterile air supply, best achieved, I believe, by filtration; elimination of infiltration of contaminated air; proper aseptic techniques in the handling of materials, instruments, and personnel coverings; isolation of critical space from less critical areas; adequate purging of the critical space around the surgical wound through sufficient air movement, maintaining flow patterns free from large-scale recirculating vortices; proper location of operating table and equipment; and an activity plan that maximizes the continuous purging of the space in the vicinity of the surgical site.

-
- 1/ Nahmias, A. J., J. T. Godwin, E. L. Updyke, and W. A. Hopkins, "Post-surgical Staphylococcic Infections," J.A.M.A., Vol. 174 (1960), pp. 1269-1275.
 - 2/ Walter, W. C., R. B. Kundsinn, and M. M. Brubaker, "The Incidence of Airborne Wound Infection During Operation," J.A.M.A., Vol. 186 (1963), pp. 908-913.
 - 3/ Whitcomb, J. G., et al., "Ultra Clean Operating Rooms," Lovelace Clinic Rev., Vol. 2 (1965), p. 65.
 - 4/ Charnley, J., and N. Eftekhari, "Penetration of Gown Material by Organisms from the Surgeon's Body," The Lancet (January 25, 1969), pp. 172-174.

Before proceeding with a discussion of possible improvements in the ventilation of operating rooms over conventional systems let us first describe the base line or reference. The conventional system will be considered to be a ceiling diffuser system with an "air change rate" of 5 to 15 changes per hour and no recirculation. Alternative approaches to achieve improvements over conventional systems may be given as follows:

A first-order improvement over a conventional system; that is, a modified dilution-purging system, can be achieved with inlet ceiling diffusers to achieve approximately 25 air changes per hour and recirculation through medium- or high-efficiency air filters; or through perforated ceiling inlets with at least 25 air changes per hour and recirculation through medium- or high-efficiency air filters.

A second-order improvement over conventional systems, again a modified dilution-purging system, can be achieved with a perforated ceiling plenum with vertical air curtain partitioning and recirculation through high-efficiency air filters.

A third-order improvement over conventional systems that I will refer to as unidirectional purging can be achieved with a ceiling filter bank inlet giving a 70 to 100 ft/minute vertical parallel airflow pattern with recirculation through the high-efficiency filters, or by inlet wall filter banks giving a 90 to 120 ft/min horizontal parallel airflow pattern with recirculation through high-efficiency filters.

It is obvious from the presentations that have already been made that there are many perturbations on the basic systems described which are possible, depending upon the details of partitioning, location of return registers, manner of entry and recirculation, etc. Quality control, maintenance and the minimization of extraneous detrimental effects are important factors.

With respect to evaluation of systems, I believe that basically there are five facets of evaluation. There is the proof testing for quality control, flow pattern visualization, biological assay, identification of detrimental extraneous effects, and clinical experience.

To meet operating room requirements, the essential performance tests are to determine whether release of a contaminant in any location will subsequently contaminate the critical region around the surgical site or sediment on any surface that might communicate directly or indirectly with the surgical site, and to determine the purge time in the region of the surgical wound. It seems to me that this is the only way that you can really determine effectiveness short of the long-term controlled clinical study.

Next I would like to elaborate a bit on the various alternate approaches referred to previously, but first a few comments about the conventional ceiling diffuser system are in order. The inlet ceiling diffuser systems with low wall exits generally result in random turbulent airflow patterns, depending on the location of inlets and outlets, and on inlet air temperature and wall and floor temperatures. Unstable, unpredictable flow patterns result. Under working conditions with surgery lights on, the flow is generally upward over the operating table, forming vortices that may permit contaminated air several sweeps over the table before being purged to the outlets. Several vortex zones of this nature may be established in the room, depending on many details, inlet and outlet locations, and location of heat sources, and wall, floor, and inlet air temperatures. If uniform mixing could actually be established with a conventional distribution system, the best achievable result would be dilution purging of locally produced airborne contamination and recirculation through adequate filters.

For a given size room, number of air changes per hour, number of viable particles released per minute, and filter effectiveness, one can accurately predict the number of particles per unit volume in the room at any instant. The only trouble is, that uniform mixing is never achieved.

The first-order improvement which I referred to previously was to spread the inlet over a larger ceiling area and modestly increase the air changes to, say, 25 changes per hour with recirculation through filters, with the objective to achieve a downward displacement system. Flow patterns in this situation are governed mainly by temperature gradients. Stanley, et al.,^{1/} (1964), through various experiments, found that air change rates from 8 to about 25 had minimal effect on the flow pattern. If the air supply is a cool air supply, that is, if the temperatures near the ceiling are less than the temperatures near the floor, there results an upward streaming at the walls and general turbulence in the room as shown in Figure 1. With a warm air supply, that is, a temperature difference of as little as 2° for the ceiling temperature above the floor temperature, a rather stable air pattern resulted with streaming down walls and horizontal striations through the center, implying a very slow downward movement as shown in Figure 2. For the random turbulence case, with the cool air supply, dispersion of the bacteria-carrying particles is completely unpredictable. For the relatively stable case, with a warm air supply, the larger particles have a maximum opportunity to settle and a minimum chance at dispersal. The small particles will follow the horizontal striations. Purging rates are low.

^{1/} Stanley, E. E., D. N. Shorter, and P. J. Cousins, "A Laboratory Study of the Downward Displacement System of Ventilation in Operating Theatres," The Heating and Ventilating Research Assoc., Laboratory Report No. 19 (March 1964).

[After Stanley et.al. (1964)]

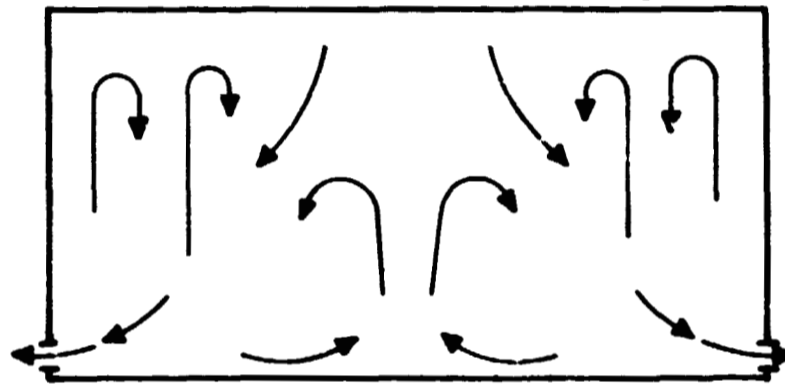

Low Velocity-Distributed Ceiling Inlet
Unstable Flow - Cold Air Supply

Figure 1

[After Stanley et.al. (1964)]

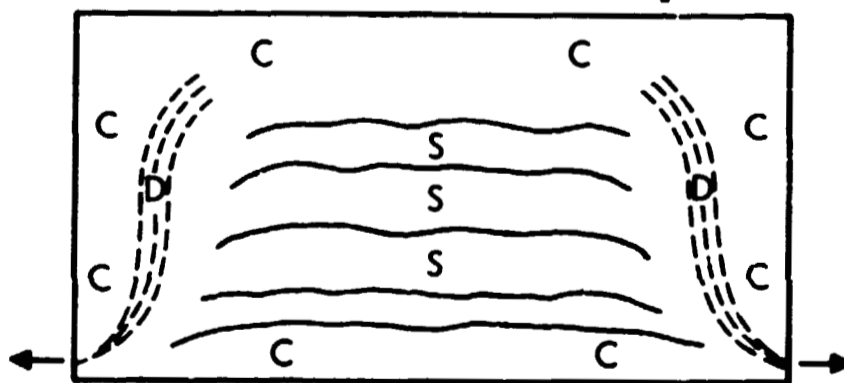

Low Velocity-Distributed Ceiling Inlet
Stable Flow - Warm Air Supply

Figure 2

To improve the purging rates, experiments were conducted with exits relocated directly below the center of the perforated ceiling. The flow patterns are shown in Figure 3. Here you see the formation of a stagnant region at the center above the table and vortices in the corners. When heat sources, that is, people and lights, are superimposed on the stabilized flow, the flow pattern changes markedly as shown in Figure 4, where airflow is directed upward in the center with large circulating vortices on either side. This permits contamination to be swept up from the lower region.

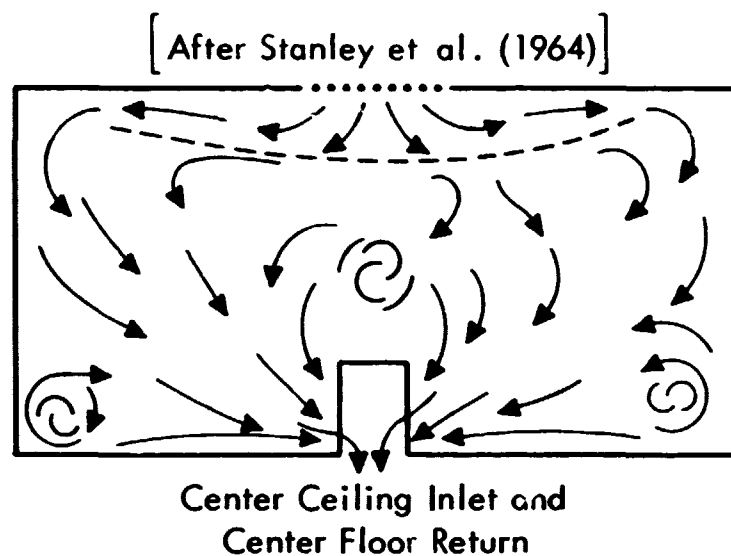

Figure 3

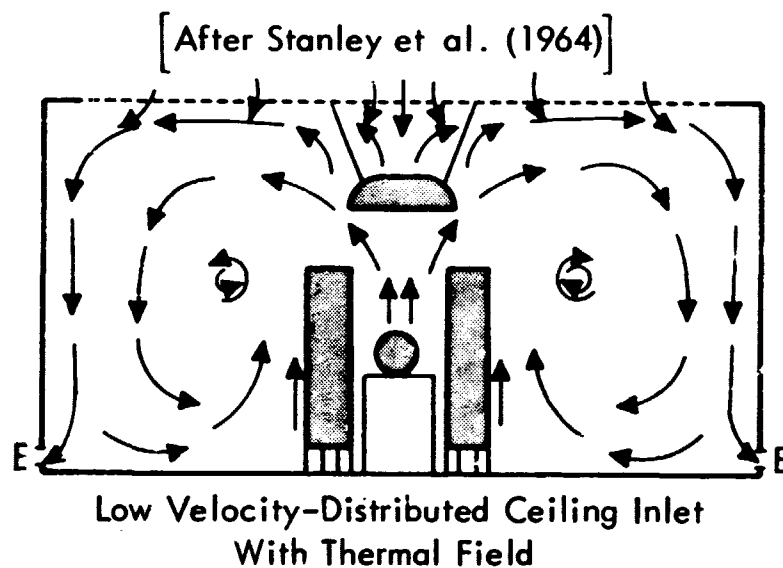

Figure 4

The second-order improvement is to increase the air changes per hour over a limited critical region, retaining the distributed ceiling inlet and recirculation through filters. The critical region may be partitioned by means of air curtains or flat-diverging air jets. Figure 5 illustrates the type of stabilized flow pattern sought, with approximately 100 air changes per hour; center air velocities at the 4-ft level are about 25-30 ft/min, while the curtain air velocity goes from approximately 80 ft/min at the issue slot to about 30 ft/min near the floor. When the thermal field is superimposed on the stabilized flow pattern, mixing takes place, and purging depends essentially on dilution; therefore, the primary improvement in this case is due to an increase in the air change rate of about a factor of four over a limited region of space.

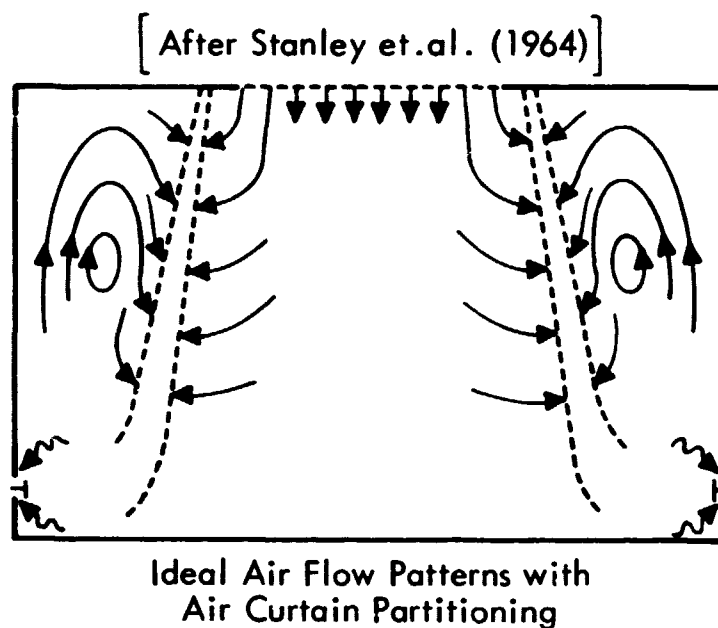

Figure 5

The third-order improvement consists of the establishment of parallel or unidirectional flow (that we talked so much about today) that continuously purges the critical space of locally generated contamination, using an essentially sterile air supply. From a technical point of view, the use of the expression "laminar flow" to describe this concept is incorrect. The meaning actually intended is stable parallel flow with small-scale turbulence only, superimposed on the main flow direction. The actual dispersion of viable particles generated at a point can be predicted as a function of distance downstream if the small scale of turbulence is known. An interesting factor is that the degree of small-scale turbulence present is influenced significantly by conditions upstream from the point of entry into the room. Suffice it to say that with stable parallel flow, continuous purging of a space is possible without the dependence on dilution.

This is not accomplished without penalty, however. Air velocities of the order of 90 ft/min are required, and if we estimate the resulting number of air changes, say, for a 9-ft ceiling, we get about 600 changes per hour, which is a considerable flow rate and requires considerable energy.

Now, as you have seen previously, several different parallel flow concepts are possible. I am not going to burden you with slides which I brought that are similar to some that you have seen today. Possible configurations include the downflow system with plastic curtain partitioning; the horizontal flow room; the horizontal flow tunnel where the critical space is partitioned off with one end open, and of course you saw another iteration of that today where actually two small vanes were used instead of full partitions. Suffice it to say that it is rather obvious that different parallel flow adaptations to the surgery are possible, depending upon the choice of downflow or horizontal flow, of the method of partitioning, of the location of return collectors, and the inlet design. There is no simple rule of thumb to be used in the identification of the best system. It is well to keep in mind that the essential requirements for airflow control are, presentation of air free from viable particles, prevention of transport of in-house contaminants into the critical space around the surgical site or sedimentation on any surface that might eventually contact the surgical wound, and finally adequate purging of the critical space in the vicinity of the surgical site.

As I said previously, and I think I should repeat, the evaluation of any system must include proof testing for quality control, determination of actual flow patterns and dispersion characteristics, identification of detrimental extraneous effects including: location of equipment, draping practice, operating table orientation, activity patterns, locations of heat sources, and finally biological assay coupled with clinical experience.

In the matter of proof testing, we are interested in detecting filter pinholes, failure of media seals or gasket seals, and in making proper damper adjustments to achieve required air velocities and distribution. Identification of extraneous effects is particularly important because the presence of any object, personnel or heat source in the space may change the airflow patterns very significantly. A considerable amount of useful information in this phase can be obtained with simply a particle photometer, a smoke source and an appropriate anemometer. Clinical experience, of course, is the final proof of the whole system and procedure.

I do not think I can stress more emphatically the fact that there is no real panacea. There are many possible systems, and the problem really is how to evaluate these. How do we determine the effectiveness of the system, or the extent to which our airflow system permits penetration of in-house contamination, produced in some part of the space from penetrating the

critical region around the surgical site and perhaps sedimenting on the surgical wound? How do we measure the purge rate? The purging of contamination that is generated within this critical region is another important function of the clean air system. It seems to me that what is needed at this point is the development of some standardized procedures or measurements that will help people to utilize their new clean rooms with the greatest effectiveness by determining how to set up their procedures, how to control movement patterns, where to place furniture and equipment.

Many thanks for the opportunity to discuss the matter of improving the air environment of operating rooms.

Mr. Post:
(Moore-Hanks Company, Los Angeles)

I wanted to ask what is laminar flow and how does it differ from the three or four things that were discussed earlier?

Professor Buchberg:

Laminar flow is said to exist when adjacent layers of the fluid remain parallel. If we were able to follow the motion of a tracer substance released in the fluid we would observe motion in the same direction as the fluid with no visible dispersion (excepting molecular diffusion). In other words, there would be no velocity component perpendicular to the direction of flow. In all "laminar flow" clean room systems there is present a small scale of turbulence, i.e., a low velocity fluctuation superimposed on the main direction of flow. Hence, small particles released at a point will suffer a certain degree of dispersion depending upon the scale of turbulence present. The engineering job is to reduce small scale turbulence to the point where it is acceptable and to prevent the development of large scale turbulence (such as large recirculating vortices) resulting from thermal fields, objects placed in the flow field, movement of people, etc. Rapid recovery from transient disturbances, such as personnel motion, is also an important requirement. Users of "laminar flow" systems must recognize these principles and seek to achieve the best possible arrangements of equipment, personnel and movement to maximize the effectiveness of these systems. For this reason, development of good evaluation tools and measures should be given high priority.

Mr. Post:

With the majority of systems that we have talked about, some with a controlled return and some without, current state of the art would seem to dictate that a facility with a controlled supply and controlled return with maximum filter area and velocities--gross velocities--averaging at 100 ft/min, that the horizontal velocities you are speaking of would be extremely minimal, and usage from that point on would be primarily a matter of discipline within the room, that is probably under current state of the art the best possible place to start and from there work on discipline within the room.

Professor Buchberg:

Accepting the velocity range mentioned earlier for horizontal "laminar flow" systems (90-120 ft/min) as being optimal, this will result in a certain base line dispersion characteristic depending upon the scale of turbulence present (or the value of the turbulent diffusion coefficient for the particular system). This base line represents the best control of contamination achievable. The same is true for the vertical flow system. When objects, people, and thermal fields are superimposed on the base line flow field it is essential that resulting undesirable effects be minimized. Yes, I believe it is important to "work on discipline within the room."

I would like to take this opportunity to mention that at UCLA we are installing a horizontal unidirectional flow tunnel system in one of the orthopedic surgeries. Our hope is to be able to develop some measuring tools that will permit us to use the system most effectively and perhaps result in a reasonable standardized evaluation procedure. I think this is needed badly.

Mr. Goddard:
(Consultant, Atlanta, Georgia)

In reply to Jerry's question there, the horizontal dispersion has been published on, and from a paper by Keith and Cowen which was work done in horizontal laminar flow room at Oak Ridge Laboratories in Tennessee, I think, if I recall it right, the horizontal dispersion factor that you mentioned could amount to as much as 14 to 16 in. in a 60-in. lateral transmission. So there is a considerable horizontal dispersion even in your parallel flow situation.

Professor Buchberg:

As I mentioned previously, the dispersion characteristics downstream of a contamination source in a uniform unidirectional flow field can be predicted if the turbulent diffusion characteristic D is known. For an instantaneous contamination source (N , number of particles), Fuchs (1964) gives for the resulting contamination downstream (n , particles per unit volume of air) the expression in rectangular coordinates,

$$n(x,y,z,t) = \frac{N}{\sqrt{(4\pi Dt)^3}} \text{Exp} - \left[\frac{(x-ut)^2 + y^2 + z^2}{4Dt} \right]$$

and for a continuous source (\dot{Q} , particles per unit time, t),

$$n(x,y,z) = \frac{\dot{Q}}{4\pi Dx} \text{Exp} - \left[\frac{u(y^2 + z^2)}{4Dx} \right]$$

These expressions hold equally for vertical and horizontal flow fields as long as the particles follow the flow patterns. The unidirectional velocity is u and x , y and z are space coordinates, x being the direction of flow.

Schandler (1968) showed interesting dispersion patterns in a Class 100 vertical flow clean room (70-90 ft/min velocities) resulting from slight room imbalances, interaction with lighting fixtures and faulty furniture placement. The dispersion of smoke released at a point was tracked by means of a light-scatter particle counter. Deviations from the base line were very considerable which again emphasizes the need for "room discipline".

Question: Why is the 100 ft/min picked out as the figure most of you quoted? Why is that a critical factor?

Professor Buchberg:

Actually, I would like Dr. Whitfield to answer this question and I would urge you to bring it up again at the panel discussion. A velocity of about 100 ft/min appears to be a reasonable value for well designed uni-directional flow systems to achieve minimum dispersion and rapid recovery downstream from flow disturbances. The range of velocities generally quoted is the result of considerable practical experience with the systems and, therefore, I believe it would be well for Dr. Whitfield to add his comments.

Dr. Skeats:
(Hospital Center at Orange, New Jersey)

I believe you said that you are going to put in a horizontal flow at UCLA. Could you give us the reasons why you selected horizontal?

Professor Buchberg:

Well, let us see; cost was one. Ease of installation on our particular space was another. Third, I felt that horizontal flow presented the possibility of minimizing the sedimentation from sources above the surgical site, such as shedding from the upper part of the surgeons' bodies. Also there is the possibility of minimizing the effect of luminaires deployed from above. Our system has not yet been installed so there is no experience yet that we can share with you. We know that it will be important to keep the space upstream from the surgical site free from obstructions, as much as possible.

SESSION III

PRECEDING PAGE BLANK NOT FILMED

THE APPLICATION OF LAMINAR AIRFLOW TO SURGICAL OPERATING ROOMS

John G. Whitcomb, M.D. .
Department of Surgery
Lovelace Clinic and Foundation
Albuquerque, New Mexico

Dr. John Whitcomb, pioneer in the application of laminar airflow to surgical operating rooms, was unable to participate in this conference. Dr. Whitcomb kindly provided us with the following summary of his experiences.

The effort and cooperation of the Sandia Corporation, Enviroco and the entire staff of the Bataan Memorial Hospital, all of Albuquerque, New Mexico, made it possible to design and install our first, vertical, laminar airflow operating room (Figure 1). This room has been in continuous operation since 3 January 1966, and this note reports on our infection rate and clinical surveillance program in this facility.

Clinical Surveillance Program: For the past 54 months we have been recording our rate of surgical wound infection and the following table gives these results.

VERTICAL LAMINAR FLOW OPERATING ROOM
(October 1966 - March 1971)
(54 Months)

<u>Room No.</u>	<u>Operations</u>	<u>Infections</u>	<u>% Rate</u>
1 (Laminar flow)	3,408	27	0.79
2 (Control)	4,162	39	0.93
3 (Control)	4,091	46	1.14

These figures are collected on a monthly basis as a confidential report form that lists the operations done for a specific month by a specific surgeon. The surgeon is asked to grade the operation as a clean or contaminated procedure and then to state the outcome of the wound healing. Tabulation of these figures is done by the operating room secretary. Notations are never entered in the patient's clinical chart; we feel that this form of reporting gets the fullest cooperation from our surgical staff.

Horizontal Laminar Flow Operating Room: New construction has just been completed at the Bataan Memorial Hospital and we are now ready to put into use our first, horizontal, laminar flow operating room. It is a large 20 ft x 26 ft room with the filter bank across the narrow, inner wall. The room will be used for orthopedic surgery concerned with prosthetic implants and for open-heart surgery.

Figure 2 is a photograph of the room taken from the entry way.



Figure 1 - First Vertical Laminar Flow Operating Room,
Bataan Memorial Hospital, Albuquerque

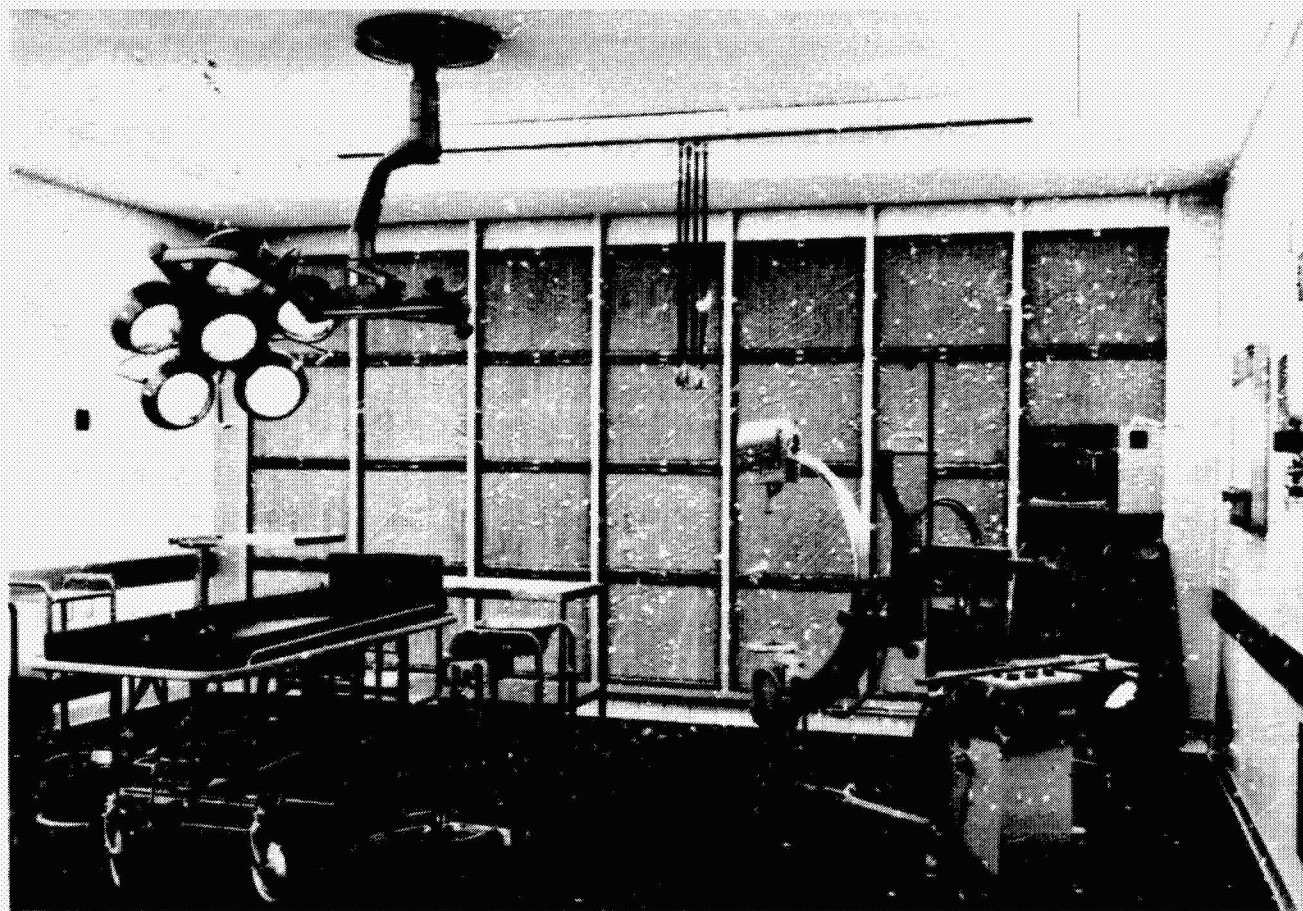

Figure 2 - New Horizontal Laminar Flow Operating
Room at Bataan Memorial Hospital

Mr. Sivinski:

Good morning, ladies and gentlemen. If you will take your seats, we will begin.

We did have a lavalier type microphone here yesterday which is not here today, and the only reason it might become important is because we will have two speakers who will give very short talks from this area this morning.

Two of the people on the panel would like to make a statement. This is how we will start out this morning. Dr. Amstutz and Dr. Leinbach have very short presentations; we will then move the panel members up onto the stage for the forum. We will then address the questions which were given to us yesterday and some of those which were given to us this morning. When I asked you to leave the questions yesterday, you answered in spades. We certainly had more questions than we can even begin to cope with this morning, so what we have done--with your permission--is that we have doled them out to the people on the panel who had some degree of competence to answer them. We tried to lump them into generic type questions and hopefully each author will get a chance to answer at least two of the generic type questions. By the time we get around twice to each one of the speakers, we believe that we will have answered 99.9% of the questions, at least in general, that you people have asked, and if we have additional time, then we will begin to go through the others in detail. We decided this was really probably the way we could most profitably spend the time this morning. We may not necessarily use the question the way you worded it, but hopefully you will see your question in the generic one that the panelist is trying to answer from the group this morning.

Dr. Amstutz is here this morning, and we will start out with a short presentation by him. Dr. Harlan C. Amstutz is the Professor in Chief of Orthopedic Surgery of the UCLA College of Medicine in Los Angeles. He has just come back from a meeting that has some bearing on what we are trying to do here and I understand he might make a comment or two about it during the course of his talk this morning.

Dr. Amstutz.

ASEPSIS AND THE OPERATING ROOM

H. C. Amstutz, M.D.
Professor and Chief of Orthopedic Surgery, UCLA

Dr. Amstutz:

Thank you very much for the introduction. I am sorry that I was unable to be here yesterday as I had wanted to be, but I do bring greetings from the Executive Committee of the Academy of Orthopedic Surgeons' meeting in Chicago. I believe you have already heard from one member of our tripartite team at UCLA, Harry Buchberg. The third member of our team, Larry Johnson, provides us with expertise in infectious diseases. I probably will not be telling you much that is new but I might emphasize some important aspects with respect to the operating room environment which do not require alteration of existing operating rooms.

Our interest stems from a high infection rate following total hip replacement which developed over a 3-year period at the Hospital for Special Surgery in New York.

Orthopedic surgeons have been acutely aware of the disastrous effects which follow acute infection in reconstructive surgery of the joints. A similar awareness is now much more in evidence because of close follow-up of total hip replacements. In our first 100 McKee-Farrar total hips (P. D. Wilson, Jr., and author), now followed a minimum of 2 years and a maximum of 4 years, there were 11 failures due to post-operative infection. Only one of these manifested itself acutely in the immediate post-operative period while 10 were latent and developed 3 to 23 months later. Of the latter patients, all wounds had healed per primum and the patients were discharged routinely following surgery. Pain, particularly in full weight-bearing situations, heralded a suspicion that some were not doing well while others functioned normally for a time before onset of pain and loss of function.

The organisms recovered were Staphylococcus epidermidis in five and one each of Staphylococcus aureus, E. coli, Herellea species with Micrococcus tetragenes, and anaerobic micrococcus. Positive cultures were not obtained from two patients although a positive smear with gram-positive cocci was obtained from one patient who was receiving antibiotics.

Both had evidence of acute inflammation from tissue removed at reoperation and are therefore considered infections. Many of the organisms have in the past been considered nonpathogenic or of low grade virulence, but our experience as well as that of others indicates that any organism can produce a serious infection.

All patients who are not doing well following total hip replacement have had one or more aspirations in an attempt to identify organisms which might be responsible for a low grade infection. Of those patients with positive cultures, not all have been reoperated although we suspect that this will eventually be necessary.

What are the possible mechanisms of infection? We suspect that many of the infections are the result of contamination at surgery. This is based on analysis of a second 100 total hip replacements operated upon using truly prophylactic antibiotics (methacillin) given before, during and after surgery. In addition, a triple antibiotic (bacitracin, neomycin, polymyxin) irrigant was used. In this group there was not one deep infection reported. Admittedly, in this analysis the follow-up period was much shorter--6 months to 18 months--but it is clear that there has been a marked reduction in the rate of infection. Other factors are to be considered, however, such as reduced operating time and blood loss, etc.; but, we have found the main factor in reducing the rate of infection has been the administration of antibiotics. On further analysis of the infected cases in the first 100 hips, all but two failed to progress satisfactorily or had one or more warning signs such as prolonged elevated temperature post-operatively or elevated sedimentation rate.

However, two patients did well and had no signs which may have indicated that trouble lay ahead. In these cases one must consider the possibility of bacterial seeding at the site of a large implant from an otherwise incidental bacteremia. Dr. Lamar Johnson believes this to be a real possibility, citing the experience of the cardiovascular surgeons who implant heart valves and are troubled with latent infections as well. Dr. Johnson states: "Transient bacteremias have been demonstrated following trauma to tissues such as tooth brushing and defecation."

There is also ample evidence to suggest that this mechanism of infection has occurred previously in orthopedic surgery. Most of us have observed patients who have had plate and screws used for internal fixation 25 or more years ago and suddenly develop pain and localized infection readily cured by removing the implant and excising the surrounding tissue. Similarly arthroplasty patients who had been doing well suddenly become symptomatic. Often surrounding bone absorption and infection is uncovered at aspiration or at surgery. All of these situations suggest to us that bacterial seeding can occur at the site of an implant.

However, if many of the infections reported following total hip replacement are iatrogenic, as we suspect, because of contamination occurring at the time the surgical procedure is performed, then all reasonable measures to eliminate the source of contamination should be initiated. The problem is particularly acute in orthopedic surgery where large endoprotheses are implanted such as in total hip replacement. An infection in these patients caused by organisms with low virulence has been difficult to control and eventually the prosthetic devices have to be removed. Therefore, antiseptic measures, especially when supplied post-operatively, have been of little benefit as far as controlling contamination is concerned. Our emphasis must be placed on asepsis.

What can be done then to produce an environment which is aseptic or nearly so? There are many relatively simple measures which can be instituted to improve the environment and these have been outlined in prior surgical literature. However, since there are so many factors which are difficult to control or evaluate, most remain theoretical with the criteria for determining the importance of any one individual factor almost an impossibility to gauge. Nevertheless, since many cost nothing and others are relatively inexpensive to initiate, I have incorporated these measures into operating room procedure. Some factors are of obvious importance and will be stressed even though I am certain they are a repetition of previous presentations given during this seminar.

Of primary concern is the size and movement of the surgical team within the operating room. The number of persons within the operating room should be kept to an absolute minimum commensurate with mission of the surgical procedure and mission of the teaching institutions. Prior to control of this factor in our own room it was not unknown to have 12 or more persons within the OR at one time. Movements within the operating room should be minimized and, therefore, organization and pre-operative planning should be maximized. Our own operating room had five doors and two of these were double doors. During one 2-1/2 hr procedure these doors were opened an amazing 186 times--over one per minute. Since each opening and closing disturbs the airflow, especially particles and bacteria which are circulating within the room, this had to be rectified. It was found, for example, that our operating room was "conveniently" placed between corridors and was even occasionally used as a hallway between the two. It is now our custom to tape shut all but two doors and to instruct the operating room team sufficiently in advance so that all needed instruments and supplies are within the operating room before the incision is made. The instruments are sequentially arranged on separate trays as described by Charnley so that they will be uncovered and exposed to the air for a minimal amount of time.

The methods of preparation of the skin of the operating personnel and the clothes they wear are quite controversial factors. However, common sense would dictate you do everything you can to protect yourself and the team from the patient. For example, due to frequent breakage of gloves in orthopedic surgery we use double gloves. The use of masks covering hair and beards is also a basic requirement. Regarding the patient, we believe that it is not satisfactory to prep the night before. Surgical technicians frequently nick the skin while shaving a limb, particularly over bony prominences, leaving an area open for bacterial multiplication. We would like to prep all of our patients for major implant surgery on the morning just prior to surgery. Since we haven't convinced the administration of the necessity to change to this schedule, the interns and operating room nurses must do this chore using one of the preparations containing Iodine.

While transferring the patient, strive to choose a route so that the bed or gurney, which has been in the so-called "dirty" areas of the hospital, doesn't come into the OR.

I won't go into the preparation and cleaning of the operating room itself to any great degree except to note its importance and to suggest that all surgeons familiarize themselves with the protocol used by those responsible and be certain that the methods are acceptable.

Similarly, keep in mind the importance of good surgical principles and techniques:

1. Reduce operating time to a minimum.
2. Damage tissue as little as possible and excise that tissue unavoidably devitalized during the procedure.
3. Control hemorrhage.
4. Eliminate dead space.
5. Use suction drainage.

I might point out that repetition of the surgical procedure using the same team, in our experience, has markedly contributed to reducing the operating room time and has a positive effect on the other measures as well.

The fitness and health of the team itself is nearly impossible to screen, but operating room personnel with open wounds or heavy colds should disqualify themselves.

The most topical item for decreasing OR contamination is the introduction of a "laminar airflow system". We are looking further into the operation of these systems because there are no statistical data one way or the other to prove their effectiveness. Since we are building a new operating suite, a laminar airflow room is planned back-to-back with older style rooms, providing a perfect opportunity to do an in-depth study with an engineer and a microbiologist present to help with the study.

The question is essentially whether a vertical flow or horizontal flow of air should exist in the OR. We hope that, from our study, data will be obtained which will be useful in determining the value of a horizontal high velocity system compared to the conventional, more or less random low velocity flow. Hopefully, data will emerge from those using vertical systems as well. I want to emphasize that improving the operating room environment is important and the simple inexpensive measures are the

first and easiest to introduce. However, there is a cost factor which must be considered in any major overhaul of the OR environment and we feel it should be based on performance, not speculation.

The use of a vertical high velocity airflow system makes it prerequisite to use some type of "space suit". This type of equipment makes communication more difficult and inhibits teaching. In addition, lighting remains a problem and particularly when using the lateral approach to the hip with the patient on his side--a preferred approach for some--and for those who must use their operating room for other procedures. The lights must be positioned laterally in the vertical flow room from the side in order not to introduce undesirable vortices due to objects or heat impedance. We have no substantiated proof that by using a horizontal airflow system we can eliminate this space suit, since it will be difficult to place the OR team so that flow is undisturbed, but we think that it is a definite possibility and plan to find how effectively we can work without a special helmet, gear and so on. We do not at this time believe that this is feasible as far as a vertical airflow system is concerned. Lighting should not be a problem with the horizontal system although careful evaluation of this factor is in order. Perhaps with development of fiber optics, lighting can be improved for the vertical system so that it will minimally disturb the flow of air.

Also, we need to consider the size and the temperature capacity of the room and of the air within the room. For example, at our institution, including the new suite and other rooms, the air comes in at 68°C. This could not be lowered without a large financial investment because of the need for the installation of additional expensive equipment. Any of these high velocity systems which are installed on a portable or permanent basis are going to raise the temperature a few degrees, soon causing it to rise above the tolerable level. By modifying what was already planned for our particular operating room, an inexpensive nitrogen cooling system could be installed to cool the air to 65°C and keep it at 65°C.

As I emphasized before, improving the operating room environment by initiating the simple inexpensive measures should be the first step. Each institution should analyze its own requirements as far as improvements needed in its airflow systems. There is a considerable need for all of us to develop one standard protocol in order to evaluate the effectiveness of the vertical and horizontal laminar flow systems, especially with respect to the all-important statistics of reduced infection rates. The use of prophylactic antibiotics appears to substantially reduce the rate of sepsis in major implant surgery.

The following issues remain to be decided:

1. How effective and practical are "laminar flow" systems in minimizing contamination and infection?
2. Will it be safe to perform major implant surgery in a "laminar flow" room without prophylactic antibiotics?

We feel that only through the actual initiation of a laminar flow system can we formulate a situation offering a plausible basis for objectives and realistic comparison to conventional systems now in use.

PRECEDING PAGE BLANK NOT FILMED

NEW HIPS FOR OLD; TOTAL PROSTHESIS REPLACEMENT

Irwin S. Leinbach, M.D.
Orthopedic Surgeon
St. Petersburg, Florida

Dr. Leinbach:

Ladies and gentlemen, I would like to first express my gratitude for the privilege of enjoying your intellectual companionship during the past several days. It was through the kindness and courtesy of Mr. Claude Marsh that I came here and, incidentally, through the thoughtfulness of Dr. Joseph Snyder, that I was kept informed about his activities and new developments in laminar airflow for surgical suites.

I listen to many of the discussions about why I do not have this and that: "It costs too much;" "My administration won't let me have it," etc., etc. In a court of law this is not sufficient reason. It will intimidate both the defense and the plaintiff. It is not an excuse for not having something good. Fortunately, I have been able to eliminate this problem. I spend some of my own money. I cannot wait for an administrator to tell me I cannot spend \$20,000 for a clean operating room. If I have it, I spend it. It is deductible, and after all it is only money. So money is only a relative thing, but maximum benefit to the patient is a tangible thing, and must be offered. So when the administration says to me, "We don't have \$15,000 to put into a clean room," I can say to my wife, "Instead of tithing it to the church this year, we'll give it to the hospital." That is exactly what we did.

There is general agreement that contamination of surgical wounds comes from three sources: contact, endogenous and airborne. Contact is a major source as shown by the universal adoption of aseptic procedures such as surgical scrub, gloves, masks, gowns, sterile supplies, and equipment. We all seem to agree that endogenous bacteria are a major source of infection whenever the skin is broken and especially when a hollow viscus is entered during surgery. Since the time of Lister, there have been major disagreements about the relative importance and frequency of airborne infection in surgical wounds, and this continues today. I came here confused, but now I am confused at a much higher level. But it does not bother me really, for someone once said that "Not to be confused means not to be properly informed."

For what reason am I here? I have been hired to deliver something, and I am going to do it as quickly as possible. I shall try to give the engineers an idea of what a surgeon does who replaces hip joints in a clean air environment.

I moved to St. Petersburg because it is a collection center for hip pathology, either disease or injury. When I first came, some days we would operate on five hip fractures. Twelve orthopaedic surgeons operate in St. Petersburg on about 3,000 hips a year, so this operation with which we are concerned, namely, total replacement of the hip, is useful.

We call this a salvage procedure because it is a destructive operation. It is a salvage procedure at 60 and over. Then after we used the total prosthetic replacement for 10 years, we decided to reduce it to 50; now we call it salvage at 50. If a 22-year-old comes to me who has had bilateral cup insertions at 15 years of age and they are worn out at 22, I might put in a total prosthetic hip in one side, especially if she wants to be married. That is exactly the case I am talking about--a 22-year-old who has had cups put in at 15, cups worn out at 22, painful hips, rheumatoid, wanted something done with one hip, mainly for toilet facilities. She was informed that the life expectancy of the hip would be about 10 years--then repeat it.

Figure 1 shows a type of prosthesis, a total replacement which is put in without cement. This is a variety that I started with before I felt that cement should be used and before I had approval from the FDA to use cement. The upper portion is the acetabular component which is screwed into the ilium, and I prefer, like No. 2 and No. 4, nonfenestrated so I can cement them in if I think they are loose at a later date. If you use cement in a fenestration, you have a problem. You knock not only the prosthesis out if you have to change it, but you could bring a piece of the femur along with it.

Figure 2 shows another variety which is the McKee-Farrar prosthesis with the studs on the acetabular component, nonfenestrated. I did 125 of these and then I felt that it was logical to use the high-density polyethylene pelvic component and I prefer this now. However, with new machining, the coefficient of friction has been reduced, so perhaps we will go back one day to the metal-to-metal.

Next (Figure 3) is a picture of a patient who has double replacements; incidentally, there is a gentleman with me who is a consulting engineer, who is sitting in the audience now who has two of these. This is a replacement, longer stemmed, in a patient who is very porotic, who had no head or neck of the femur when she came to me. We were able to restore 2-1/2 in. of length in this patient.

Figure 4 shows the Charnley type, the low friction coefficient, high-density polyethylene, small head; it is very popular. I think, and I say this truthfully, that if I were learning to do prostheses and wanted to know how to reconstruct as well as replace, I would advise learning the Charnley method. I use five methods which I fit into the type of patient in whom I think they belong. For instance, a man with a large medullary canal where I would probably have to use two or three units of cement, I would rather use more metal and less cement. It is only my opinion, and it is an opinion gained from an impression after experience; with nearly 500 total prostheses in 3 years.

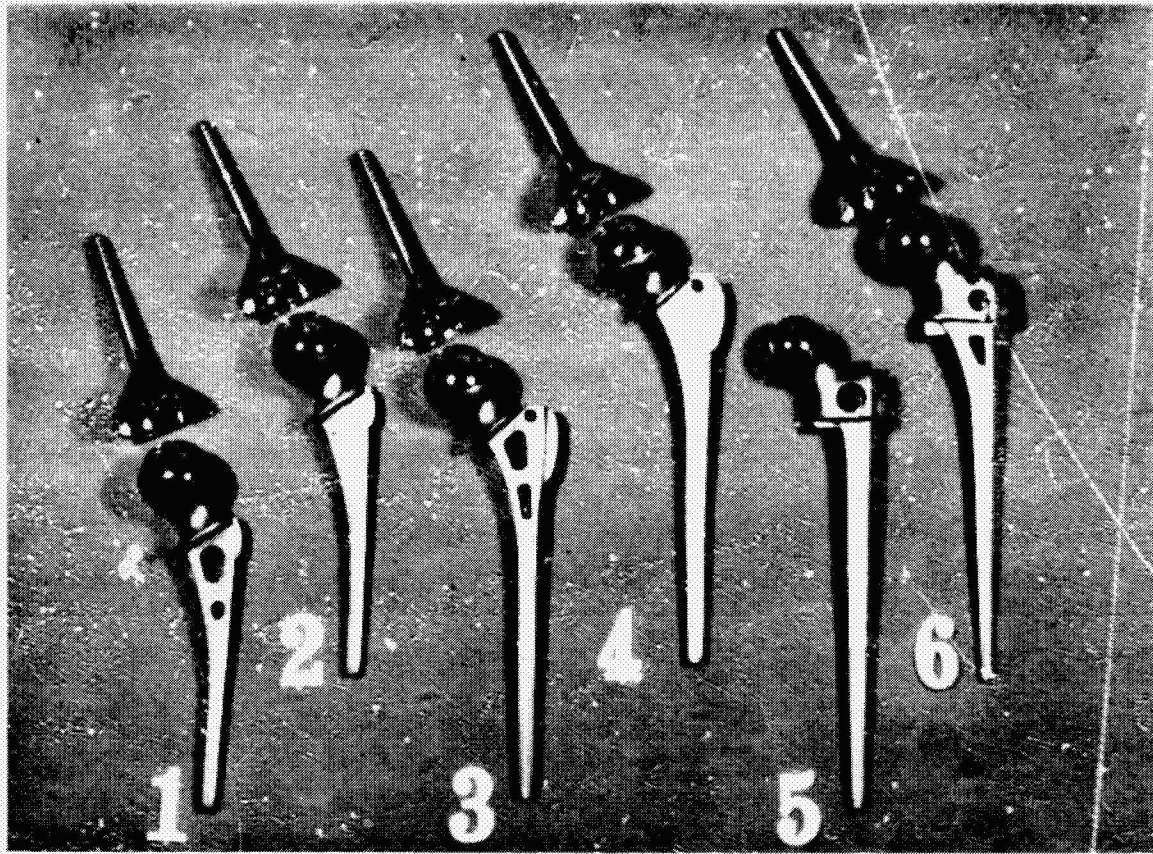

Figure 1 - Ring Prosthesis. No cement used in regular techniques. Cement can be used for more firm fixation in non-fenestrated stems.

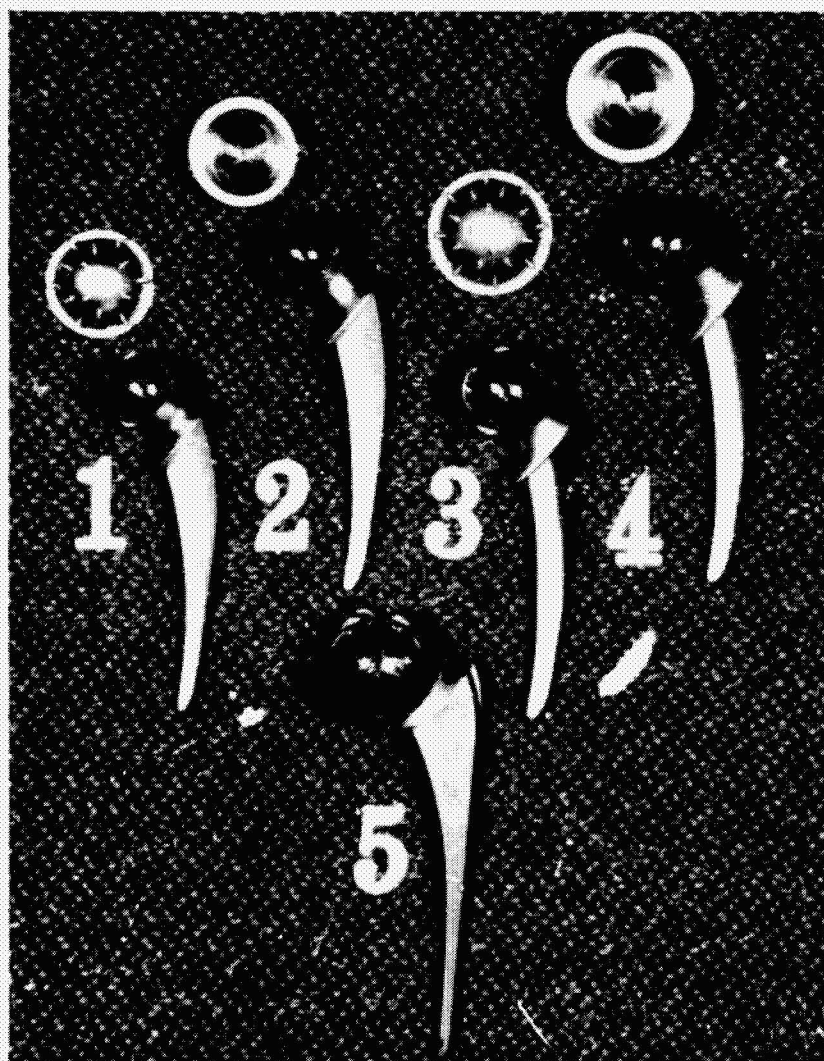
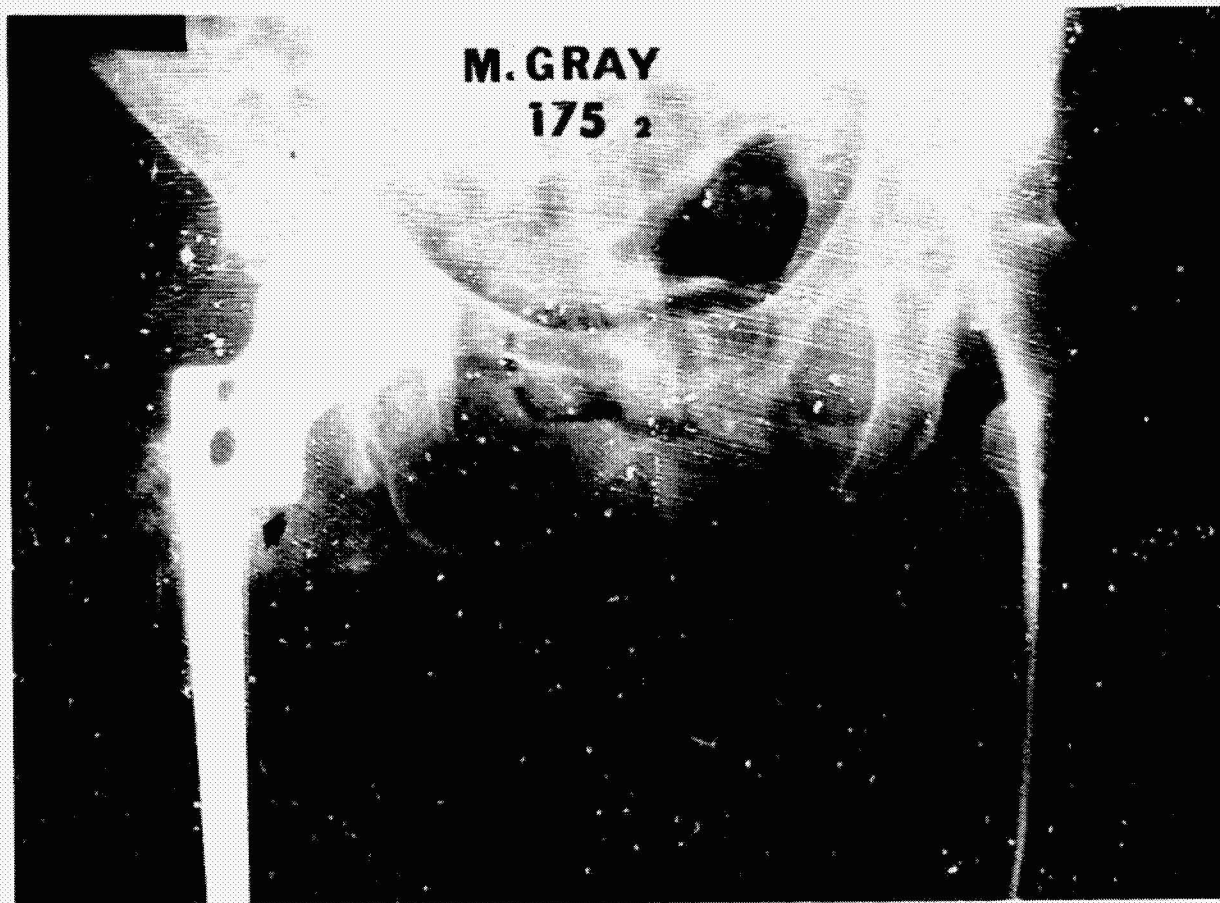

Figure 2 - The McKee-Farrar Type Total Hip Prosthesis



(a) Double hip replacement. Note the two screws in the ledge of the socket to reenforce the lateral shelf.



(b) Shows a woman who had no head or neck of the femur.

Figure 3 - Total Hip Replacement

**VITALLIUM
CHARNLEY-TYPE
TOTAL HIP PROSTHESES**



Photo courtesy of Hawmedica, Rutherford, N.J.

Figure 4 - Charnley Type of Total Hip Prosthesis

Figure 5 shows a unipolar prosthesis in place, the one on the left. This is a unipolar prosthesis which will eventually pound its way into the pelvis, you cannot hammer metal against bone like that and expect it to remain stable; it can become loose and painful. I would say almost one out of three of these are "built-in" failures.

Figure 6 shows a Müller-Charnley type which I use and I prefer because it has variable neck length; I can restore some muscle tone without removing the trochanter. If the trochanter is in abutment against the ileum, I take the trochanter off and put it back with screws and wire.

Figure 7 shows Müller's variety; look from the left and to No. 1 you have a short neck, the medium, and the long neck. You have, in the upper left-hand corner, a small polyester acetabular component; the next one is polyester; the next one is a high-density polyethylene. The polyesters are very handy if you operate in foreign countries, you can use moist sterilization. You can take these polyesters along and autoclave and boil them up in a minute and a half to 3 min. When you have variance in the canal; for instance, if you have a long, thick medullary canal, where you might have to use three units of cement, you can take No. 3 and put it in there and fill it up with metal rather than cement. You do need cement, but not as much.

Figure 8 shows Weber's prosthesis, a replacement, looks like a billiard ball. We use this as a traction prosthesis. It spins on the ball; it has a very low friction coefficient; and I have used these in younger patients, and I have told them, if any of these components wear out, we make a little incision in the side, dislocate the assembly, and put in another "billiard ball." I give them one when they leave the hospital, but I also give them the name and address of the man who invented it in Switzerland.

Figure 9 shows the Buchholz German prosthesis, a high-density polyethylene cup. On the right you see R, up above, is a cutout for the iliopsoas muscle. I use these in people who have large medullar canals and I think I cut down the amount of cement. For example, this man had a shallow acetabulum. I use two screws to build up the lateral aspect of the ileum, or shelf. I prefer to get in deeper medial ward. In this case I could not, so I built up the acetabulum.

This is a useful suction system (Figures 10 and 11). This was simple. I do not think I have ever done anything original, but I have been a fairly good collector; I have visited a lot of people; I have picked a lot of brains, and this is a modification of the first one I saw in Charnley's clinic. We found this little crown arrangement in the welder's machine shop and adapted it to use. Figure 12 shows the way to cover the face; this is over the apparatus you just saw and I try not to have hair exposed. I wear antistatic boots made by Dunlop Rubber Company in England and they are scrubbed between cases with a detergent solution.

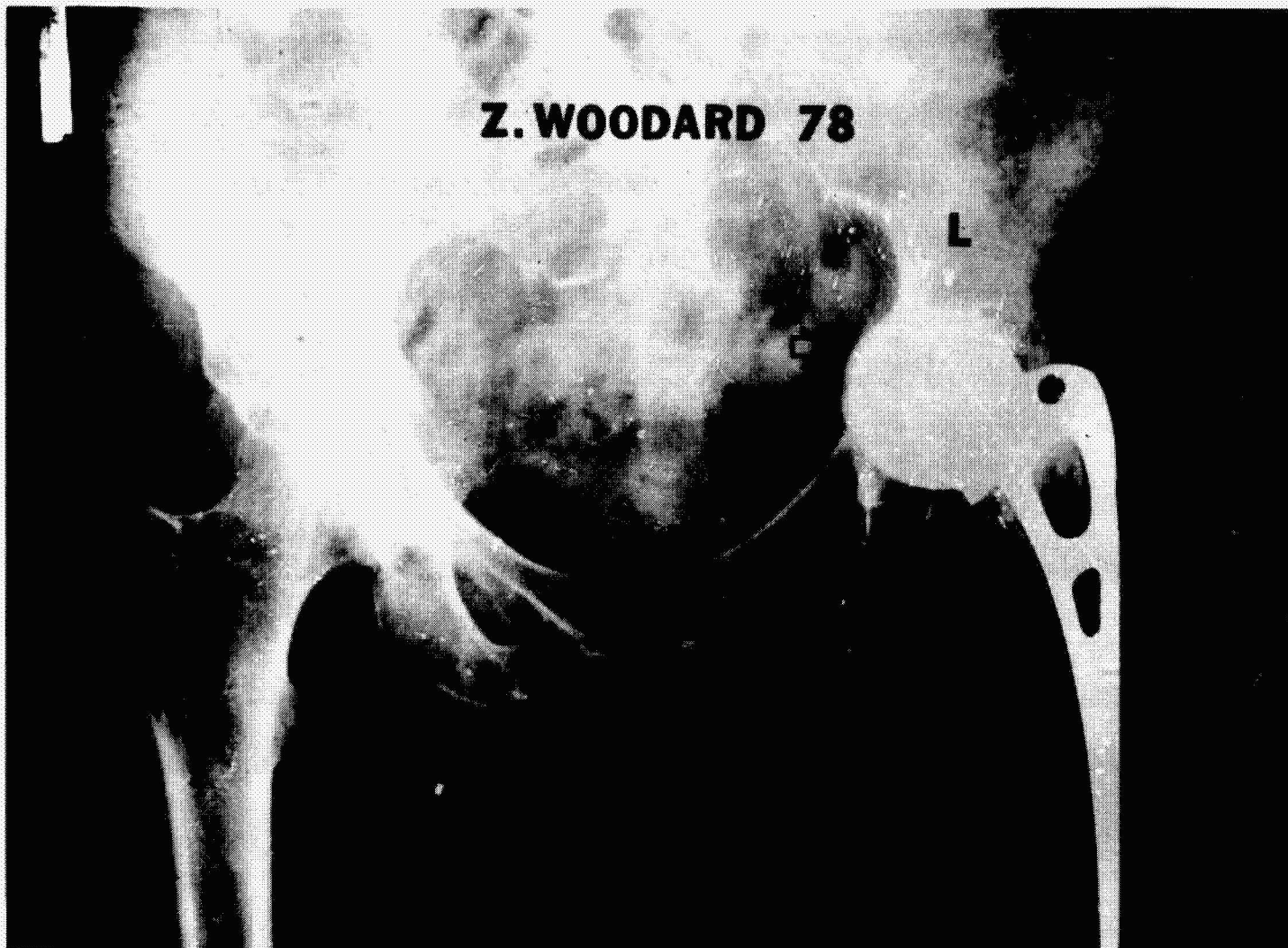

Figure 5 - A Unipolar Prosthesis

Note how the metal will drive against and eventually protrude through the acetabulum. This happens in at least 20% of the cases in the upper age groups with porotic bone.

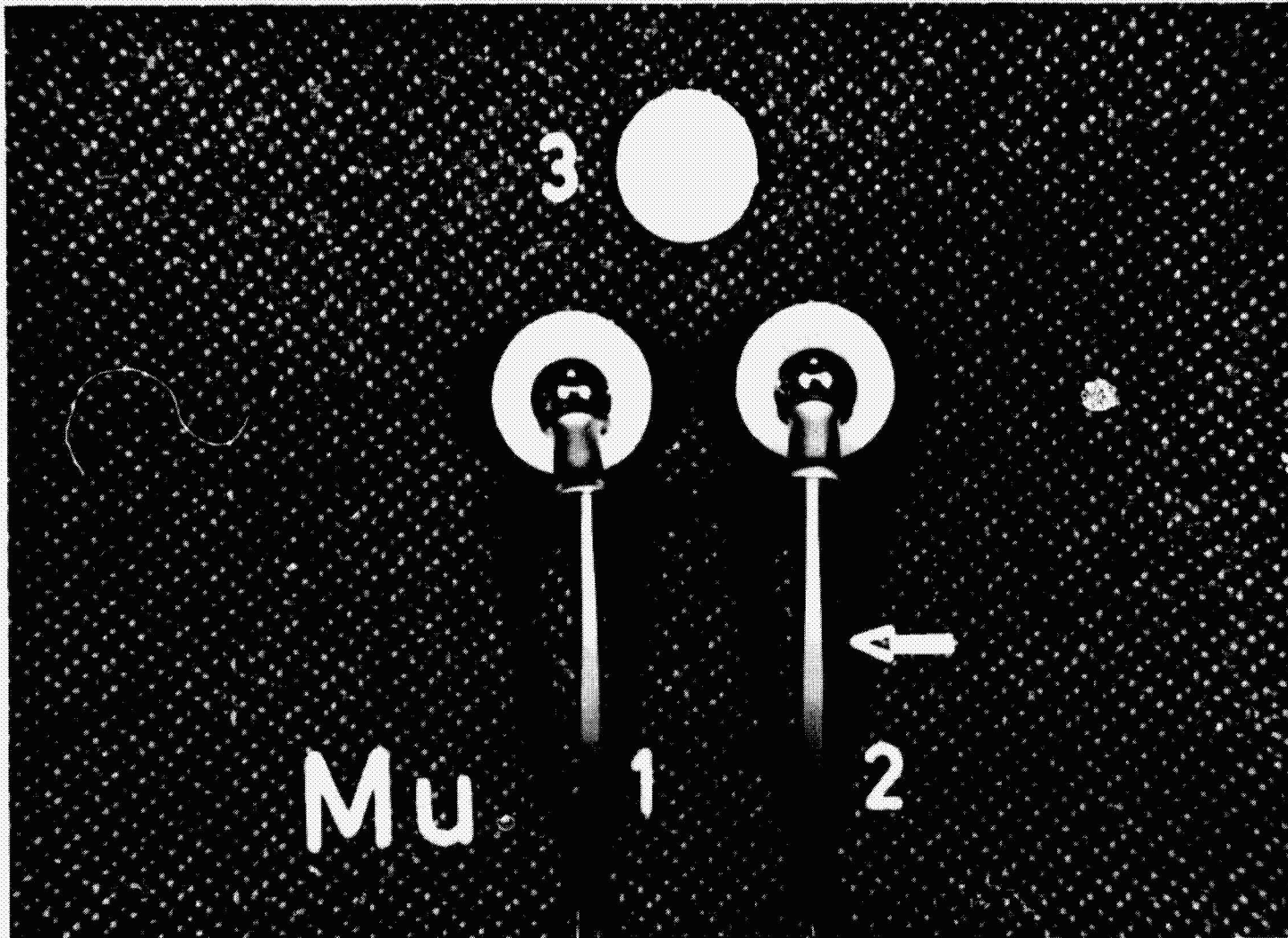

Figure 6 - Müller-Charnley Type

If the assembly needs revision the thick stem (2) can be removed and the thinner one (1) replaced without removing the cement cone. Part 3 is the smaller cup used in patients with small sockets. The head of the femoral component is constant.

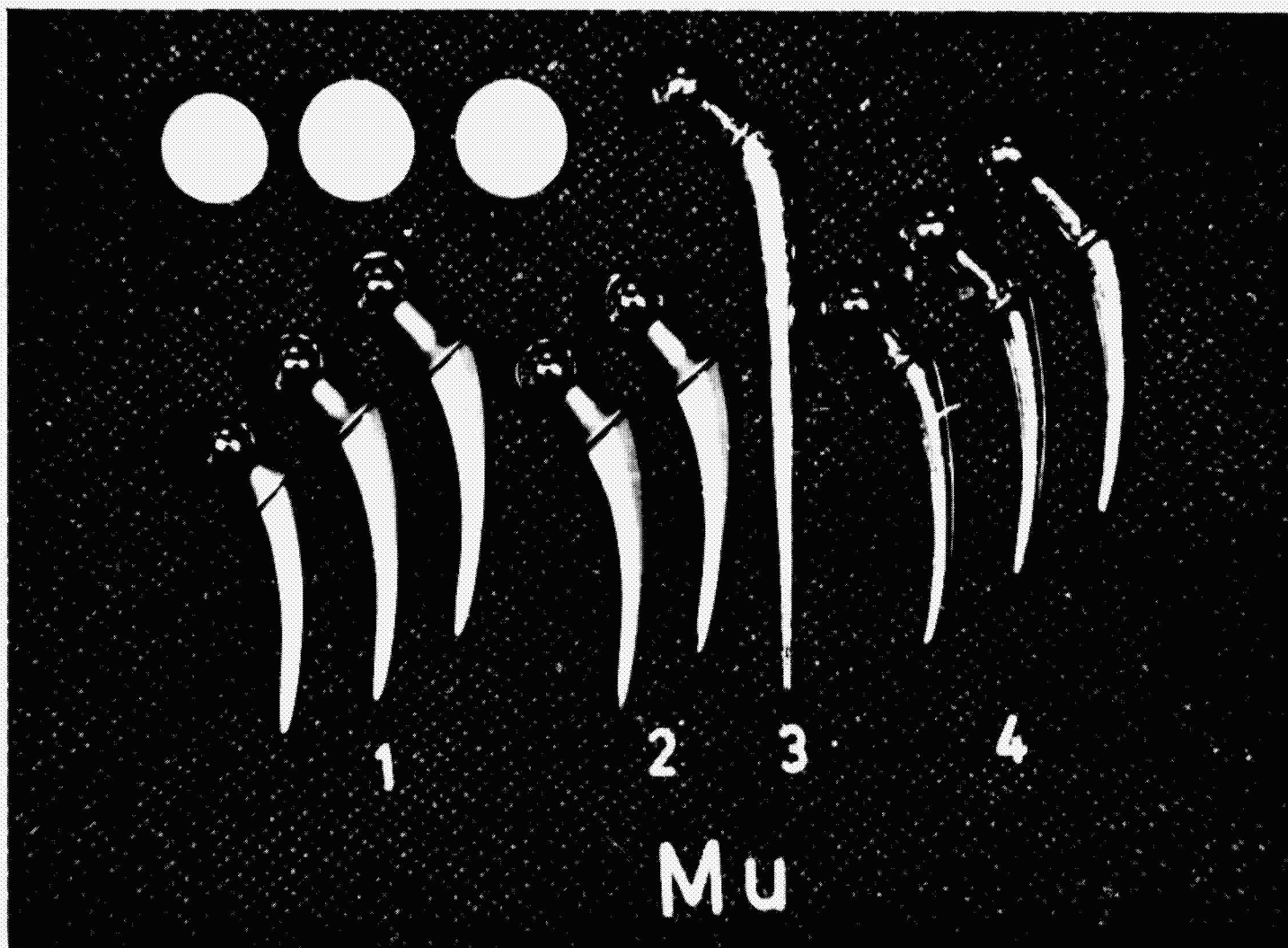

Figure 7 - Variants of the Müller Prosthesis

The white cup on the left is polyester with an outer diameter of 44 mm. The second from the reader's left is the polyester standard cup size. The third is the high-density polyethylene cup. The polyethylene must be sterilized by gas or gamma radiation. The polyester cups can be sterilized by boiling or autoclaving in the standard hospital procedure.



Figure 8 - The Weber Prosthesis Assembly

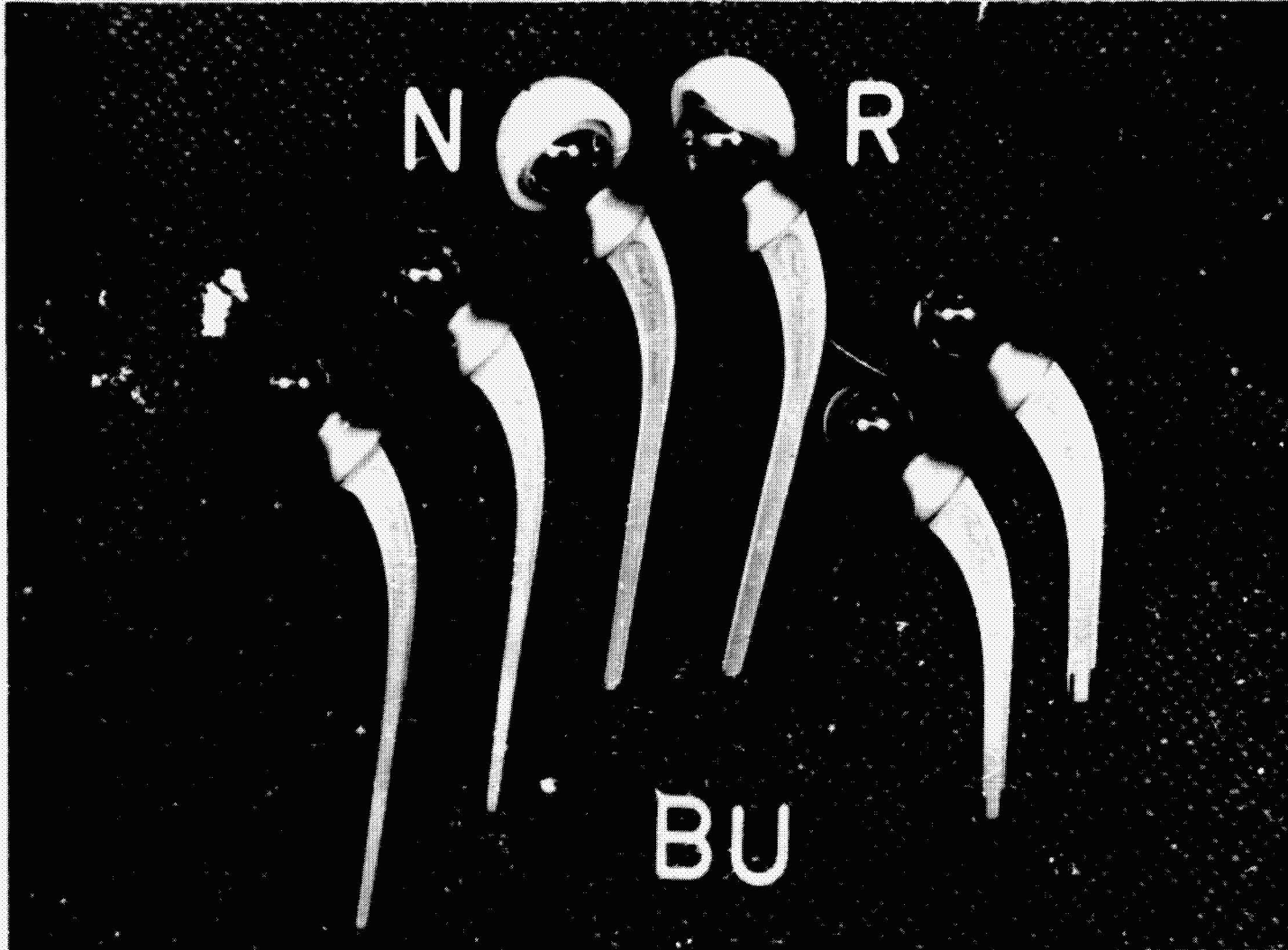

Figure 9 - Bucholz Model "St. George" (Hamburg, Germany)

This prosthesis allows about 1.5 mm of "play" between the head and and the socket. Professor Bucholz feels this approaches the normal hip more so than the "tight fit".



© Copyright 1971 Joe Scheff

Figure 10 - Front View of Suction System



©Copyright 1971 Joe Scheff

Figure 11 - Side View of Suction System



©Copyright 1971 Joe Scheff

Figure 12 - Gowning Over Suction System

This is the back view of the situation (Figure 13); incidentally, the x-ray view boxes are not in the operating room; they are outside. In the draping procedure, we have plastic on the front of us so that if we perspire, or if we push an instrument against the body, theoretically we do not contaminate ourselves or the instrument. I wear cuffs; they are simple things; my father used to wear these when he was a bookkeeper and you can buy them in any stationery store and gas sterilize them.

This is our laminar flow operating room (Figure 14). The source of light is outside. We need very little light for a hip replacement. If you put a light in there the general surgeons will want to use the room.

This room is worth \$15,000, if for no other reason than to keep the talkers away from the patient. You see that the walls are draped. We drape with paper because it is nearly lint-free. The anesthesiologist is outside of the room.

Someone else mentioned the turbulence around the operating room table. All you have to do is drape the table and run the drapes down to the floor and you have eliminated some of the problem of turbulence. You can cover the whole table. My drapes go down from the table to 4 in. above the floor.

We do not have all lint-free drapes now. We have lint-free paper on the sides, and we will begin using lint-free drapes when a particular type of lint-free material is available. After we have draped with conventional material, you can go along the outside on the ledge of this room with your finger and pick up green lint. This means it came out of the room. Without laminar flow these lint particles would still be in the operating room.

Figures 15 and 16 show the Goodrich Vacumask which I like. They are light in weight and very efficient against expired particles. I have two of these vacumasks. I will demonstrate them later. I have tested this system by smoking a cigarette, blowing the smoke, and the smoke will not pass out the aperture if your suction is adequate. Thus, you would not have to wear the polyurethane mask; however, it is not a good discipline for the other people in the room to be masked, so I wear the polyurethane mask over my face so not to violate our rules of discipline.

Dr. Snyder asked me yesterday about Dr. Weber's (St. Gallen, Switzerland) statistics on the use of vaccines to prevent infections. In 1967, Weber vaccinated none of his patients and had 11% infections. In 1968, out of 155 cases which received vaccine, he had three infections or 2%. Between January and July of 1970, he did 176 total prosthesis operations and had one infection or 0.6%. Because Weber's vaccine contains several strains of Staphylococci the FDA will not let it in this country. So, you might use an autogenous vaccine, which Dr. Ulrich says is better anyway.



© Copyright 1971 Joe Scheff

Figure 13 - Backview of Suction System



Figure 14 - Laminar Flow Operating Room

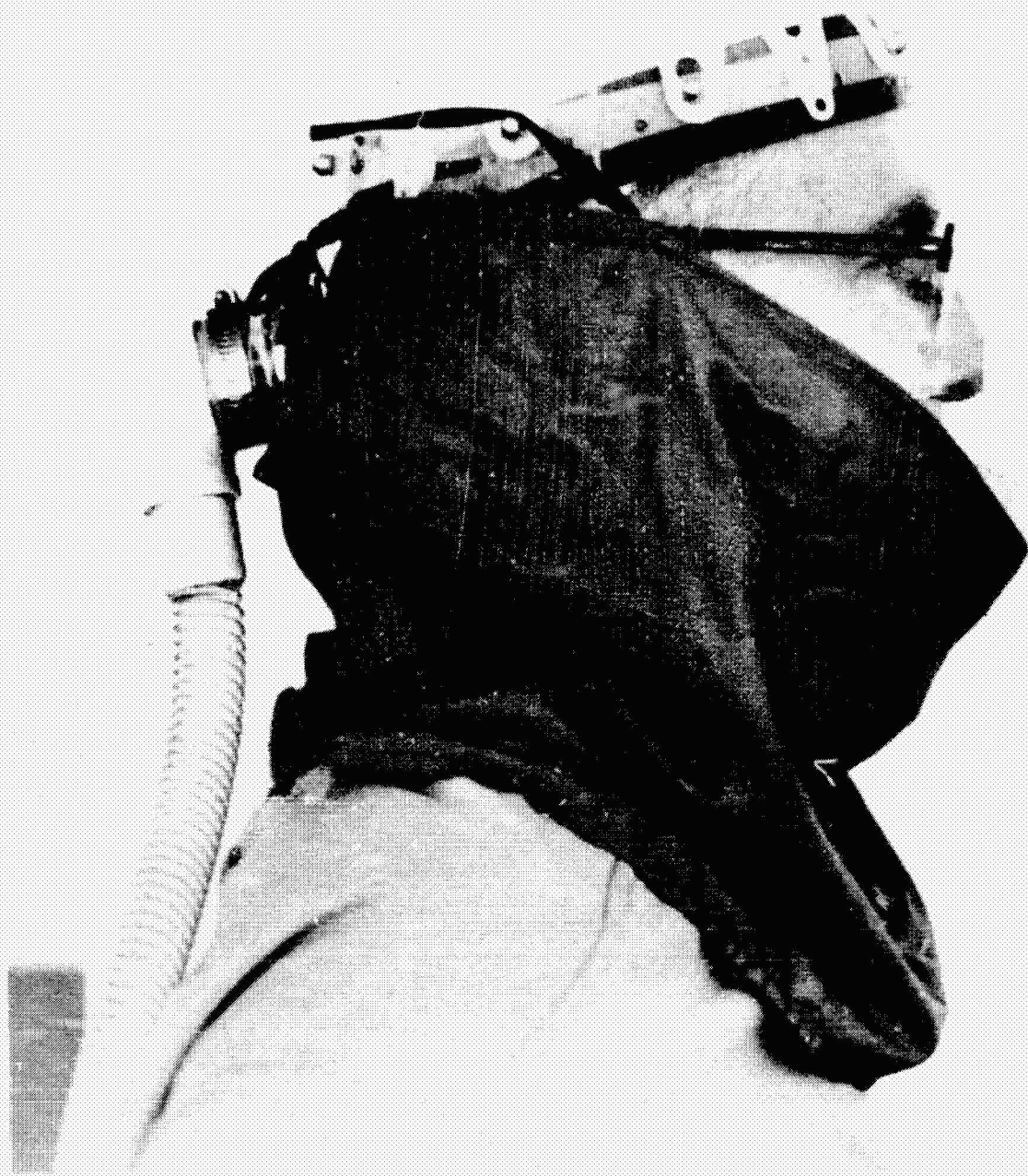

© Copyright 1971 Joe Scheff

Figure 15 - Side View of Goodrich Vacuum Mask



© Copyright 1971 Joe Scheff

Figure 16 - Front View of Goodrich Vacumask

Statistics are sometimes like a lamppost to a drunk; they offer some means of support, but they are not very enlightening. I have 19% complications, but they are not major complications. It is just a frank admission of what happens: deep vein thrombosis, 20; infections, deep, 3; dislocations, 4. However, I have never had a dislocation with the Charnley-Müeller prosthesis. I had three with the McKee-Farrar. There is no single mishap which one could call an error that has been the fault of anyone else, or any room.

Figure 17 shows my compression dressing, a big time saver. It is a modification of Charnley's compression. I have used 50-60 of these to date and have only one patient, a very obese lady, who had a small seroma at the proximal end of the wound. One may leave this compression for 8 days and have a technician remove it.

I shall be happy to demonstrate the exhaust systems to anyone who would like to see them. It has been a distinct pleasure to have shared your knowledge in exchange for a few facts from my own experiences. I thank you.

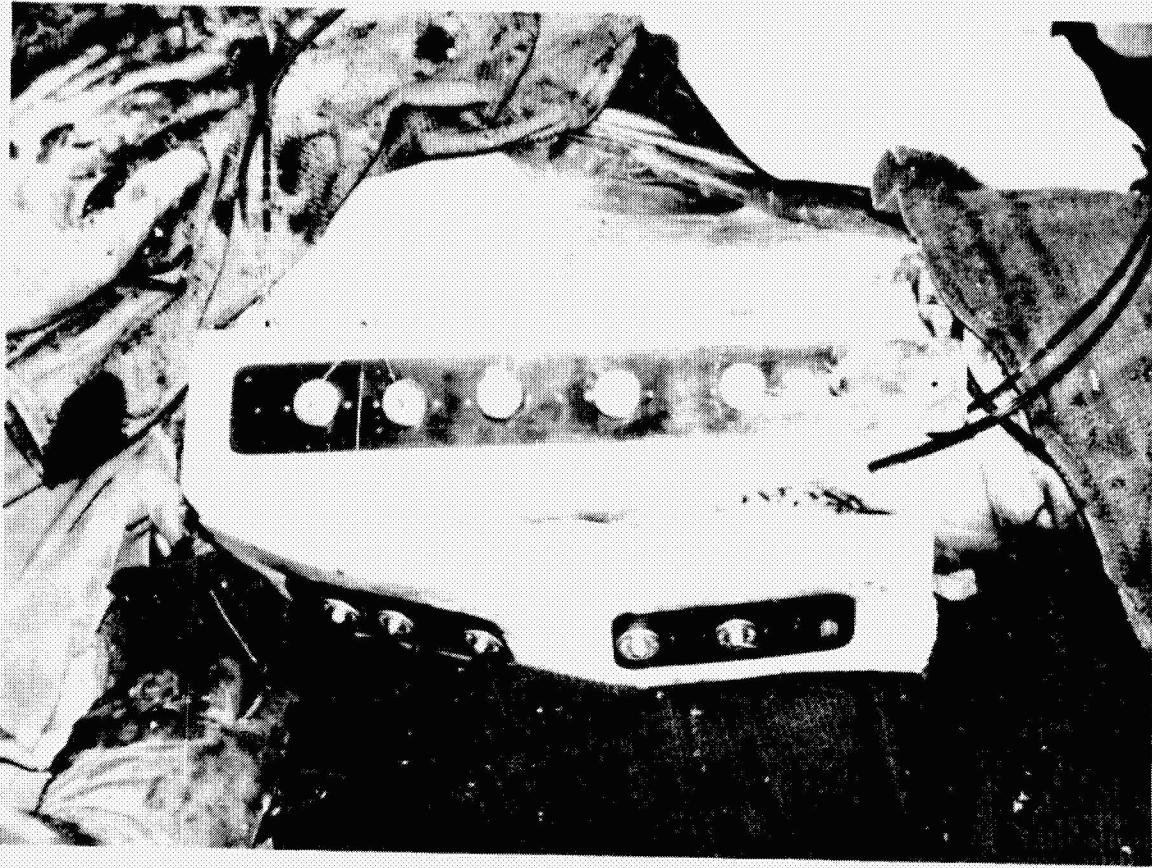

(a) The application of the upper or anterior half of the compression dressing in the operating room. A flexible steel strip is held on to a 2 in. x 2 in. strip of polyurethane foam under pressure and tension which is maintained by stainless steel wire sutures which fix the padding to the patient.

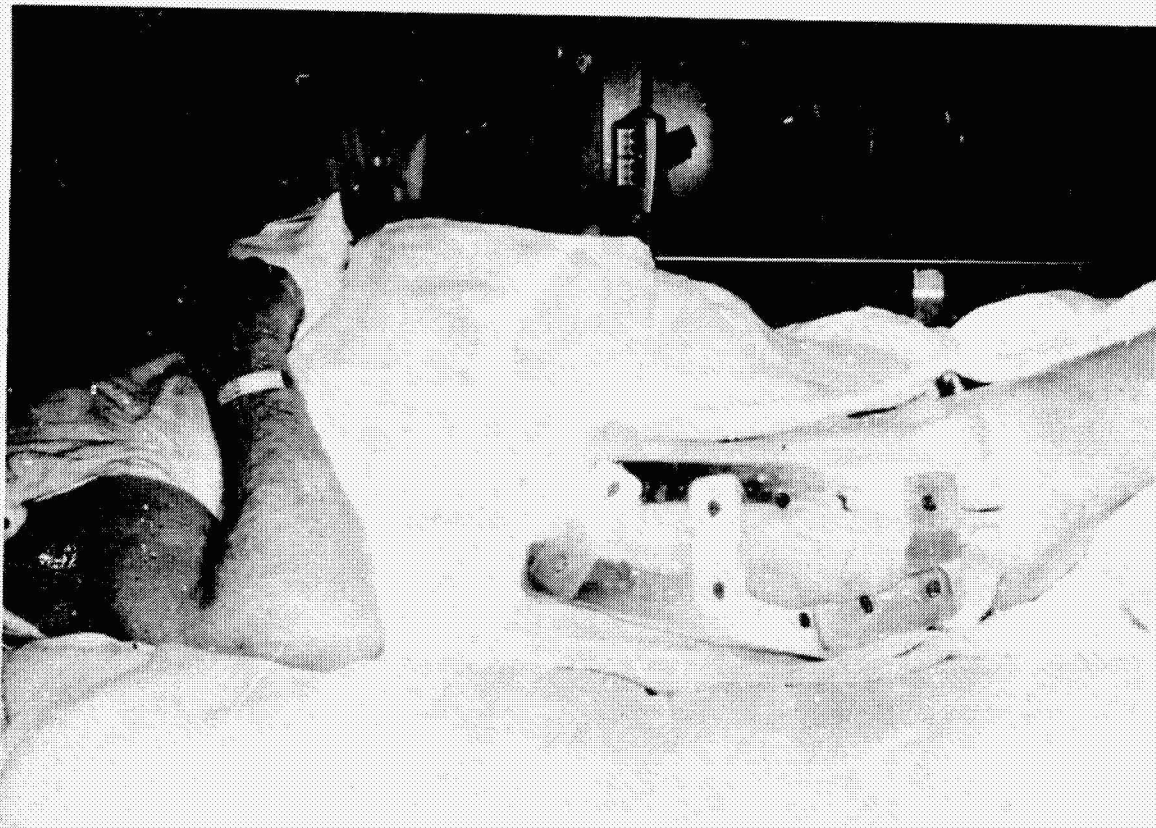

(b) The dressing in place with cross strips of stainless steel. The compression is constant and the patient is able to walk, turn, rest on the dressing without altering the compression on the fatty tissue and small vessels in and under the skin.

Figure 17 - The Compression Dressing

SESSION IV

FORUM

Panel Members

Dr. Harlan Amstutz
Professor Harry Buchberg
Dr. Alan Harter
Dr. Irwin Ieibach
Mr. Claude Marsh
Mr. Jack Sivinski (Moderator)
Dr. John Ulrich
Dr. Willis Whitfield

Mr. Sivinski:
(Moderator)

We have assigned many of the questions to the people on the panel and unfortunately, we will not be able to answer each one individually. But as I mentioned earlier, the answers to the generic type questions will cover most of those, and the remaining problems that are still unanswered can perhaps be covered individually before we are finished.

I think we will just move along the way we have planned. I took no questions; that is my privilege as a moderator so I exercised it. We will start with Dr. John Ulrich, and we will go around one time to each panel member; and if each panelist will start out with his first generic type question and give an answer to it, then we will pass on to the next person.

Dr. Ulrich:

Most of these questions are on bacteria in surgery, and I will not treat any one question; I will take it as a general discussion.

We are always going to have bacteria in a surgery. A number of you have seen articles, I looked at two of these this morning, on the use of a sterile operating room. There is no such thing; as long as you have a human being in the room, you have got an unsterile situation. Essentially, what we are trying to do is control the numbers and also the removal of these organisms, so they do not contaminate the wound.

When an organism does contaminate a wound, there appears to be a difference of opinion whether that organism is one that has derived from the patient or has come from an outside source. The best data--as far as the staphylococci are concerned--were compiled when the investigators checked the patients as they first came into the hospital, and periodically through their stay. These data show that organisms that the patient did not have when he came into the hospital, caused more severe and prolonged infections than organisms that he brought into the hospital with him. Again, I think it is probably true that we are able to live a little bit better with our own bugs.

One of the questions here was, "Do we have antibodies against our own indigenous flora?" To some of them, yes; to many of them, no. At least, not on levels that are demonstrable. We do have other general systems, however, that are present in all of us, for example, against staphylococcus. All of us normally have serum components that will cause coagulation of staphylococci. This is a good thing in some cases, because it can cause clumping. It is bad in others, in that with clumping, it is probably harder to treat with antibiotics. There was also discussion this morning on prophylactic use of antibiotics. There is considerable literature on prophylactic

use. Investigators on both sides are equally vocal and equally concerned as to whether antibiotics should be used prophylactically. There is one large group who feels that in many cases we direct infections by the type of antibiotic used, especially with gram-negative organisms, particularly Pseudomonas, which is one of the most difficult organisms to treat. It may be that with at least some prophylactic regimens, we may actually be endangering the situation.

Dr. Whitfield:

In looking over the questions, Jack, there is one that seems to be rather common: How can turbulence be avoided over a surgical wound when vertical or horizontal laminar flow hits the surgeon's arms or hands? To me, the answer is that you cannot avoid turbulence. I think the thing that you need to consider is keeping harmful contamination out of this turbulence. After listening to the surgical people talk yesterday and this morning, it appears quite clear to me that you are worrying about single-particle contamination. We were worrying a few years ago and still are about this in the electronics industry where a single particle could possibly give us trouble. In that case, you go to extreme measures to avoid single-particle contamination. From what I have heard at this symposium, the proper use of clothing is very necessary in avoiding single-particle contamination, even in vertical or horizontal laminar flow systems. I know of no way to eliminate the turbulence in either of these systems, although obstructions that cause turbulence should be minimized as much as possible. The objective here is to keep contamination out of the turbulent area.

Dr. Amstutz:

The question I have is: What is the official position of the Academy of Orthopedic Surgeons regarding the use of laminar flow in surgery suites? At the present time, there has been no announced official position from the Academy. However, I do have some background information which reflects my own personal view and many others within the Academy Executive Committee who feel that total hip replacement, where the components are fixed with the cement-like substance (methylmethacrylate), has advantages, particularly with respect to loosening over the total hip replacement prosthetic devices which are press fitted into bone. There are data which suggest that there will be significant incidence of loosening, while at least through periods of up to 8 years polyethylene-metal total hips seem to remain well fixed. However, the use of methylmethacrylate has been restricted by the Federal Food and Drug Administration to a group

of investigators around the country. The short-term safety and efficacy has now been established and methylmethacrylate (Simplex P brand) is scheduled for release. The package insert will contain the usual warnings and will make reference that the operating room should be provided with adequate air circulation. There is no mention about "laminar airflow" per se, and I believe there will be none until such time that adequately controlled studies are available to substantiate or deny the need.

Dr. Leinbach:

I have a question here from Dr. Joseph Snyder (Presbyterian Hospital, New York). He asks, "Is there an optimum airflow rate?" I recall that it was suggested in one of the references the range would be 25 to 60 ft/min. Below 25, you get thermal convection currents, and above 60, you get undesirable vortices. Dr. Snyder also says the New York City Board questions the explosion hazard of recirculating air in an enclosure. Is there pro and con evidence that the recirculation of air in an enclosure will or will not result in generating a potentially explosive mixture? I have a comment about it; the National Fire Prevention Act refers to tests which show that the dilution rate is so high that actually 1-1/2 ft from the source there is no explosive potential, and no explosive hazard has been found. Recall also, that even in a recirculating system, fresh air must be introduced at a rate of five out of 12 changes so that if the air must be introduced, and there is an equal amount, you don't run the hazard of dumping contaminants and so forth into your area. I don't know what the Act says, but I would say with this interchange of air and the fact that you must have fresh air in with the recirculated air, that you reduce the hazard considerably. Seriously, I would consult the hospital attorney about this before you just assume what I am saying is true. You don't get a build-up of particles if you have air change, especially at the flow rate that we use.

Dr. Ulrich:

Just one little point, as far as explosion hazard is concerned: the people most concerned are the underwriters, and they have stated that this is no longer a hazard in surgeries.

Dr. Leinbach:

I agree with this. As a matter of fact, you should go one step further and get your room certified and exhibit the certificate. If it does nothing else, it alerts people against negligence and it shows them

that you're aware of the hazard. You can have a room certified easily by the manufacturer. It will cost you \$400 to certify a room; you bring in \$5,000 worth of equipment to do it.

Dr. Carl Nelson:

I wanted to ask, then, why do you have your room posted with "No explosive anesthetics will be used in this room?"

Dr. Leinbach:

We have no hazard because we do not use cyclopropane. We use spinal anesthesia in 90% of the cases and this is one of the reasons. You don't allow things against your own interest. But when you are not allowing these, you publicize the fact that you are doing everything possible to give the patient maximum surgical and medical benefits.

Mr. Sivinski:

Willis, we actually did some studies too, instrument studies, to determine what the explosive levels were in a laminar downflow operating room at Bataan. Do you remember the results of that work?

Dr. Whitfield:

Yes, it certainly agrees with what Dr. Leinbach stated here. There was no buildup at all.

Question:

Would you comment on paper versus plastic drapes and the patient's body temperature; also the merits of paper or plastic drapes versus linen?

Dr. Leinbach:

I cannot suggest anything that I am not entirely familiar with as to the pros and/or cons. Paper is supposedly lint-free. Nonwoven fabrics have the advantage of disposability and eliminating the laundry factor. At the moment, I am investigating a product from the E. I. du Pont de Nemours and Company, Wilmington, Delaware, which is a gown, sterilized by the manufacturer and returned to the same laundry for reesterilization. The Micron-Clean Uniform Service, a division of Valley Linen Service,

Inc., M.D. 25, Newburgh, New York, offers white-room garments, cleaned to government-micron specifications. These manufacturers give the pros and cons for the use of their materials. At the present time, I am using paper drapes which are waterproof and nearly lint-free.

Question:

A doctor stated that doctors know more about laminar flow as it pertains to hospitals. Is this a possibility?

Dr. Leinbach:

Let us first define "possibility" as an uncertain thing which may happen. Therefore, it is a possibility, but more so if the doctor is an engineer as well. Up to now, and certainly in the future, engineers will play a greater role in infection control through their contributions in contamination control. One must get to the source of the contamination. We as physicians know about the endogenous sources. We speak of an infection being haematogenous. An engineer knows that personnel and equipment are the source of exogenous material and other contaminants. Humans shed bacteria. The average nude person sheds 50,000 bacteria per cubic foot per minute. It is my contention that there should be no bare skin exposed in the operating room. It should be covered with fine closely knit material which is filter-type woven cotton. Much of the material discussed in our conference is well covered in the Biological Handbook for Engineers, NASA, CR-61237, given to all those attending the Symposium. Had this handbook been distributed prior to the meeting, many questions and their answers would have been eliminated. The material distributed at this Symposium is invaluable and should be abstracted and published for general availability to the medical profession at large.

Dr. Harter:

I have a question here pertaining to the prevention of infectious disease in astronaut crews. The questioner asks "What steps has Kennedy Space Center taken to isolate the astronauts from preflight infections?"

In almost 80% of the Apollo Missions, one or more of the crew members have become ill, either before, during, or after the flight. These illnesses have usually been viral in origin and of the so-called "low-grade" type. However, it should be pointed out that a runny nose or mild diarrhea which may be only a nuisance here on earth, could reach very serious proportions in the hostile environment of Space--not that the disease itself would be different, but that even the slightest degradation in human performance might have grave consequences for the success of the mission. Also, the space suits and the spacecraft, itself, have not been designed to cope

with the special problems presented by a sick crewman to himself and his fellow astronauts.

To prevent the occurrence of preflight infectious disease, a multifaceted program was adopted for the final weeks before launch. This program consisted of: (1) isolating the crews to the maximum extent possible in a clean room environment; (2) limiting their contacts to approximately 150 individuals; (3) keeping these individuals, called "Primary Contacts," under close surveillance for infectious disease; and (4) maintaining a catalog of illness, if you will, in the Brevard County, Florida area.

The Flight Crew Training Building and the Crew Quarters were identified as those places where the crew would spend most of their time during the final preparations for launch. These areas were set up on separate air conditioning systems incorporating 0.3 μ filters. Positive pressures were maintained in these systems relative to adjacent areas in the same buildings. Access to these areas was restricted to the primary contact group. When in the course of their schedule activities, the astronauts were required to spend time in nonrestricted areas, they either donned biological filter masks or else the nonrestricted area was cleared of all individuals save the Primary Contacts for a period of 1 hr before the astronauts arrived there.

In the crew kitchen, special precautions were followed for the procurement and preparation of food. Drinking water samples for residual chlorine and approximately 40 random swabs for bacterial culture were obtained daily in the crew areas. Special antiseptic cleaning procedures were employed in the daily cleaning of the living areas, kitchen and bathrooms.

Every effort was made to ensure that the primary contact group was free from communicable disease. Comprehensive physical examinations were carried out on these individuals when the program got under way. In addition to the usual laboratory work, the examination included chest x-rays, throat cultures, stool cultures, and serum titers for such viral diseases as Rubella, Rubeola, and mumps. Immunizations against nine viral and bacterial diseases were administered. The Primary Contacts were then placed under close surveillance for communicable disease. At the slightest symptom, they were evaluated with appropriate physical and laboratory examinations and removed from Primary Contact status if disease was detected. The health status of family and other contacts was also a subject of concern. Illness at home or chance exposure to communicable disease was reported to the Health Surveillance Team. Close check was kept on the illness running through the community by liaison with the County Health Department, the public schools and the local medical community.

It was important to attain a comprehensive knowledge of the communicable disease prevalent in the area. Viral cultures, antibody titers and symptom complexes were all utilized to catalog disease.

Armed with an inventory of Brevard County microflora, we felt that we had a head start on the diagnosis and treatment of symptoms that might crop up in the astronauts. Preflight microbiology studies were done on the persons of the astronauts. Knowing the bioburden carried by the crew when they left on their mission, more meaningful data could be acquired about the effects of space flight on these microflora by comparison studies after the astronauts returned to Earth.

You may be interested in some of the results from the mission of Apollo 14. The observation period ran roughly from the middle of December 1970 until the middle of February 1971--the height of the winter virus season for this part of Florida. Among the primary contact group, we experienced an incident of illness 1% per day with a prevalence of 4 to 5%. Close to 95% of observed illness involved the upper respiratory tract. The primary object of the program was achieved. The Apollo 14 crew was launched in good health and remained free from disease throughout the mission and the 3 weeks quarantine period which followed it.

In summary, this health maintenance program, though new and somewhat cumbersome, may have considerable significance on future concepts of the control of communicable disease among healthy populations.

Professor Buchberg:

Mr. Edge (Powell-Edge Architects, Florida), posed the following questions: Airflow--what are optimum speeds, temperatures, and humidities? Velocities--where does turbulence begin? That is, at what speed does air begin to not flow smoothly around a curvilinear object?

Beginning with the first question dealing with "optimum" values of the design parameters, air speed, temperature and humidity; let me say that seeking an optimum implies the existence of a criterion function which has not been defined by the questioner. In the design of engineering works we generally would like to maximize the benefit/cost ratio. It is not yet possible with the systems under discussion to define a benefit/cost function. Therefore, the specification of optimum values for various design parameters is not possible in a technical sense. The best that can be done now is to suggest a range of values for each of these parameters that reflect the experience so far accumulated, including knowledge of specific effects investigated over many years. For "dilution" or "modified dilution" purging systems, no air velocity specification is meaningful because

of the random nature of the flow. For unidirectional flow systems, the suggested velocity is 90 ± 20 ft/min in the empty space. This specification comes about from the integration of the following experiences:

1. Pressure drop through new HEPA filters is less than 1/2 in. H_2O which is a reasonable fan specification and assures long filter life;
2. Purging and recovery from transient disturbances is rapid;
3. Normal flow is reestablished a reasonable distance downstream from small blunt bodies;
4. For well-designed systems, the dispersion downstream from a point source of contamination is within acceptable bounds providing a succession of critical spaces are not located downstream from one another;
5. Based on Stoke's law for spherical particles, 20μ or less in diameter, the vertical drop in a horizontal flow field will be about 1/2 ft or less in 10 ft of horizontal displacement; and
6. Perception of air movement is minimal--equivalent to standing in a 1.5 mph wind.

The specification of air temperature and humidity is quite elusive. If it is acceptable to base thermal requirements on Comfort Criteria, the ASHRAE* recommendations which are based on subjective experiments with human subjects performed by investigators over many years should be applied. The recommended thermal condition is described in terms of an arbitrary index (Effective Temperature, ET) which accounts for both air movement and humidity but essentially neglects radiation exchange. To achieve thermal neutrality ASHRAE* recommends an ET of $68^\circ F$ during the winter and $71^\circ F$ during the summer. These values should be slightly amended to take account of radiation exchange with elevated temperature surfaces such as luminaries. The desirable ET value must then be translated into combinations of air temperature and humidity taking account of air movement and personnel activity level.

Factors other than comfort also need to be considered in the operating room. For example, it has been shown that relative humidity held between 50 to 55% is more lethal to certain bacteria than lower humidities. The minimization of drying potential near the wound site may also be important. ASHRAE recommends a relative humidity of 50% for operating rooms.

* "Handbook of Fundamentals," published by the American Society of Heating, Refrigeration and Air-Conditioning Engineers, Chapter 7 (1967).

To answer the second question: "Where does turbulence begin, that is, at what speed does air begin to not flow smoothly around a curvilinear object?" let us consider what happened when a long (6 in. diameter) cylinder is immersed in a uniform velocity flow field such that its axis is perpendicular to the direction of flow. For Reynolds Numbers (Re) less than about 0.5 or an air velocity (v) at 80°F less than 0.01 ft/min, the flow pattern is perfectly symmetrical about the axis of the cylinder. At $Re \cong 10$ or $v \cong 0.2$ ft/min a definite small zone of separation forms downstream of the object. At $Re \cong 50$ or $v \cong 1$ ft/min the wake develops a waviness or oscillation. At $Re \cong 200$ or $v \cong 4$ ft/min a well developed system of alternating vortices downstream of the cylinder is observed and finally at $Re \cong 10^4$ or $v \cong 200$ ft/min the wake becomes fully turbulent.

I am not sure of the point the questioner had in mind, but one thing that can be inferred is that after air flows through a HEPA filter bank and protective perforated plate at a face velocity of about 100 ft/min there is superimposed on that flow a scale of turbulence. However, the important point in the "laminar flow clean room" concept is that essentially unidirectional flow results in the rapid purging of a space of particles generated in the space or particles that penetrated the space from without. Small scale turbulence superimposed on the flow does not alter the purging quality. It is only when larger scale recirculating vortices form in the critical space that the cleansing effect is degraded.

Question:

What is the ideal temperature for a laminar flow operating room?

Dr. Leinbach:

I wanted to comment on that a bit ago. There has been recent literature in the AMA Journal about this, that the ideal temperature for the patient is 75°. Dr. Bechtol and I have discussed what is the ideal, comfortable temperature for the surgeon--we are paying a little attention to him too, and I will discuss that--and someone also asked me if we can eliminate oral exhaust systems with laminar flow? But if the AMA writes an article, or someone with relatively good documentation does so, and states that the comfort of the patient, the ideal physiological temperature for him in the operating room is 75°, and if you reduce him to 65° and he has a chill, the chill constitutes a type of shock. So I think ideally you would keep the patient's surrounding temperature at 75°; you may have to use hot water bottles around the parts not inside the "sterile room."

Dr. Ulrich:

I just wanted to fortify some of the statements on humidity where bacterial survival is concerned. Staphylococci survive least well at 50% relative humidity. Gram negatives die off very rapidly at almost any humidity below 65% so 50% probably is optimal.

Comment:

The comment I had was referenced to the optimal temperature; obviously, that is a bit controversial. I think that--I have not seen any data on measuring the temperature of the patient adjacent--underneath the operating room drapes, and I think this is where the problem arises, that if the surgeon is working in a room that is 68° and has a relatively impermeable gown, or paper drapes--the old soft gowns have obviously permitted much more evaporation than the paper or plasticized unit--and in that situation if you work in 68° you very rapidly become too warm; at least I do, especially when working. Now the patient is also under a series of drapes and I'm sure that his temperature does not fall to the room temperature. Now, when you are working in an exhaust system, then that is, of course, quite another thing; then I think your temperature could be up, but I think you have got to define which system you are working in and also the rate of flow that you are working in too, because if you are working in a crossflow or downflow system then without anything you are obviously going to be cooled more rapidly than you would in the usual conventional operating room.

Dr. Whitfield:

I think this whole thing is buried in a rather complex series of considerations, when you are talking about airflow velocity. The statement made about the increased turbulence occurring with the higher velocities is true for some limited conditions; however, the thing that you must consider in this framework is that more rapid recovery or cleanup occurs even in turbulent zones, with higher airflow velocities. Generally speaking, in an industrial clean room situation, which is not too unlike what we are talk about here, the higher airflow velocities will usually result in much er contamination levels, because of the more rapid recovery in turbulent areas as well as the entire clean room due to better particle flushout capabilities.

Mr. Marsh:

I am the only one on the panel that has not spoken before, so I am not answering any previous discussion. I would like to discuss a number of questions related to an area that has been mentioned, but not

discussed. This is the best method for frequent checkout of the filters and evaluation of the performance of the laminar flow system. In addition, I want to point out the importance of certifying the clean room itself as well as evaluation of the total situation, including the surgical procedure.

I wrote a paper many years ago about the application, or the adaptability of laminar airflow, which described the clean room as a tool that can be well defined. How that tool is applied, and in this case, how it is applied to surgery gives rise to considerable discussion as far as the clean room itself, particularly the laminar flow room. We know quite precisely what its capabilities are. They have been evaluated industrially for quite a number of years, and just to reiterate, in the laminar flow room two things are paramount; one is the filtration efficiency, the second is the airflow pattern. These two factors basically define the room performance and must be carefully evaluated to assure optimum performance

Filtration efficiency basically has to do with the removal of particles. The most effective way to evaluate this parameter is to introduce a particulate challenge to the system and then see how many of the particles go through. The standard filters are high-efficiency filters which have a manufacturer's specification of no greater than 0.03% penetration at the 0.3 μ level. This can be established by creating an upstream particle challenge, measuring that challenge, putting the challenge through the filters and then measuring downstream. The level that is established in the Federal Standard is no greater than 0.01% penetration. This was specified because the typical challenge is not homogeneous. Air operated generators are normally used which give a particle distribution with some larger particles and some smaller than 0.3. The 0.01% penetration value, thus, exceeds slightly the 0.03% penetration allowed by the filter manufacturer on 0.3 particles. It is also a good range which is easy to achieve with the available instrumentation. The test is accomplished with a light-scattering optical device which provides an immediate readout of the event of leakage. So this then establishes the efficiency of the filters. This relates to Dr. Whitfield's paper, and one other speaker who showed the potential of the filter system leaks. This includes the filters themselves as well as the construction quality and integrity of the room system.

The tests should be done about every 3 months because of the aging factor and the economics of testing these systems.

The second factor, then, is airflow. Airflow can be simply measured with a velometer and with visual smoke pattern tests. Limits again are established by the Federal Standard at 90 ± 20 ft/min average flow rate. Certifying the filter efficiency and the airflow characteristics in terms of velocity and direction establishes the efficiency of the room.

The efficiency of how that room is applied or adapted to surgery and the assessment of its medical efficacy is a question which must be primarily answered by the medical profession.

Question:

Did I hear you correctly--did you recommend that filters be changed every 3 months?

Mr. Marsh:

I recommended that they be tested this often. This is our experience, which has been verified in industry.

Question:

How do you know when to change the filters?

Mr. March:

The filters must be changed when the airflow can no longer be maintained by the air fans. In other words, the measurement of the airflow will determine when the filters must be changed.

Question:

Isn't this extremely important from a legal point of view?

Dr. Leinbach:

Right. A point about checking the HEPA filters. If there is a question of negligence action against the hospital, in the earthquake area, the first question I would ask is, since you had the earthquake, have you checked your HEPA filters?

Question:

Should a portable unit be tested each time it is moved?

Mr. Sivinski:

You probably should because every time you move a portable system or you make some structural change, or something like that, the integrity is very apt to be violated. You need to do this periodically. And Claude has brought up a good point; you need to do it even if you do not have an earthquake, and another point too, is measuring how dirty your filters are. You, of course, measure this by the amount of air pressure drop across the filters. If there are no holes developing through them, they still tend to clog up over a period of time; however, the life of HEPA filters is sometimes fantastic. In very dirty areas, use good clean prefilters and change them regularly. We have got systems that have been going--how many years?--5, 6 years, and that is good because HEPA filters are not cheap--they are one of the most expensive parts of the clean-room installation.

Dr. Leinbach:

I question the expensiveness of HEPA filters. How much are they? Eighty dollars apiece? This is not too high a price for clean air.

Mr. Sivinski:

That is true. But that is not the only cost; that is just the cost of the acquisition. The actual installation, recementing, and testing with a photometer of every square inch of that face; it mounts up to considerably more than that. I do not disagree with what you are saying; do not misunderstand me. But, you do not get it out of petty cash--the secretary does not carry it around.

Comment:

Another point, in checking HEPA filters and particularly in horizontal flow rooms where the filters are somewhat susceptible to damage, is an occasional visual check. This is a very wise idea in the case of a ceiling bank or in the case of a horizontal filter wall. They're very easily damaged, and a very quick visual check even almost on a daily basis is a good idea.

Mr. Sivinski:

By the way, I did not introduce Mr. Claude Marsh here on my left--on your right--who answered the last question. We have all gone around one time, and we will give the boom operator a chance to answer a question which came in here addressed to one of the speakers who was here yesterday,

Dr. Carl Nelson. Is Dr. Nelson here? The question is: "Is your module made by DePuy-Agnew?"

Dr. Carl Nelson:

It was made by Agnew-Higgins.

Mr. Sivinski:

Do you have trouble keeping people out of the upwind area?

Dr. Carl Nelson:

No; you just don't let them go there.

Mr. Sivinski:

Okay, then anyone--this third one is addressed to you too; do you bring beds into the OR?

Dr. Carl Nelson:

Yes, and we are changing that now so that we have an apparatus to transfer them to the operating room and not let it go beyond the mark in the surgical area.

Mr. Sivinski:

Here is another general question; "Cannot the air be cooled in the clean-air system to prevent the rise in the room temperature complained of or does it have to depend on a separate efficient air conditioning system in the operating room?" Of course, that is an architect-engineer type problem. If you have a complete system on recirculating air that also pulls out so much air, air conditions it, and brings the temperature down as you are bringing it in, sure you can have a system that, in fact, does drop the temperature down. Whether you have got room to do this when you are changing existing facilities, is a horse of another color; very frequently it is difficult, because it does take a lot of space; it takes refrigeration, new air, makeup air--this kind of thing. So the answer to that, of course, is an architect-engineering problem, as I say, but it can be done. But whether it is possibly based on the dimensional limitations you have, if you are changing an existing room, you have to have your A&E department take a look at that problem.

Professor Buchberg:

Jack, I think Claude may want to talk about the peak cooling capability incorporated in our system; that is, liquid nitrogen cooling.

Mr. Marsh:

I have no knowledge of the details of that system.

Professor Buchberg:

Well, I thought you knew the details of it. This was a case where the available hospital air conditioning was insufficient for peak load requirements. The basic concept is to inject liquid nitrogen into the air stream as required during peak load periods.

Mr. Agnew:

(Agnew-Higgins, California)

We have a very fortunate circumstance in this regard of additional heat. If you put equipment of this nature into an operating room, it is very likely that you are adding a heat load that the room is not designed to take care of. And this accounts for the temperature rise that we have been hearing about. But there is also a built-in factor called 100% exhaust. These air changes that are brought through the surgical suite are exhausted to the outside atmosphere, and not recirculated. So in every operating room we have 3 or 400 cubic feet of air we are going to throw away anyway, and in our system we throw that out through the laminar flow equipment; therefore, it picks up the heat and exhausts it and does not allow it to get into the occupied area.

Miss Peers:

(Association of Operating Room Nurses, Colorado)

A very mundane kind of question; the emphasis has been primarily on orthopedic surgery, except for Dr. Clark's discussion on cardiothoracic surgery. Am I hearing from this panel that the optimum would be for laminar airflow in all surgery rooms, or is this only particular to the problems that you have discussed orthopedically.

Dr. Leinbach:

We want to give everybody the best, and if we agree that we need discipline in these units that we are talking about--let us start from scratch and say, "Can I prove that this clean air room has made a difference in my surgery from the standpoint of reducing infection?" I cannot.

But I know what it has done to my personnel. I operated in South America 10 days ago; there were 22 surgeons in the room talking Spanish, and when Spanish is spoken, the bugs are stronger; I mean, they do it with emphasis and even the garlic that they have on their breath will not kill the bugs. But there were 22 people in the surgical amphitheater standing around me. When I first started with my present total hip operation, there were three and four people observing. Now I do not care whether there are six or seven. They are outside the enclosure. Not only that, what about the personnel; will they wear hoods? Will they wear the masks? Will they do what I ask them to do? They will if you have a set of rules and say, "Here is a room; this is an enclosure; we are proud of this; and everything is cleaner here than it is across the way." This is a discipline; you begin with some rules and regulations, even if you have to build a box around it. Certainly the neurosurgeons will use your room; and so will the thoracic surgeons. I read recently about new hospitals in Australia. The entire suite of operating rooms are HEPA filtered. So your question would be answered by what are other people doing. If the Australians can have clean air all over, I think we should; I think it constitutes a maximum environment. Everybody is polluted. You saw the film here yesterday. If I drive from my home to the hospital and I follow a bus, I am certainly contaminated when I get there. And another thing that no one mentioned, I worked for my uncle who was an orthopedic surgeon. He would not allow us to have a BM the morning we operated unless we wore gloves for cleansing. Human feces are more than 50% bacteria. And before we operated, I soaked my fingertips in 7% iodine for 3 min. Think about all these little things. You clean up the whole room, and all of a sudden you bring a bunch of boobs into this room; like a Cadillac with a hippie convention in it.

Dr. Amstutz:

I think that Miss Peers has presented us with a very germane question and I am not certain where the current interest in "laminar air-flow" will lead us. There are definitely surgical procedures which have a higher risk for infection. At my former institution in New York, the Hospital for Special Surgery, I think the statistics would show a negligible infection rate in clean hand cases and others have shown that a very low rate can be anticipated even when there has been significant contamination from hand injuries as long as there has been proper surgical debridement. Obviously, then the hand is a special anatomical area which would be considered low risk. Perhaps this is due to abundant blood supply or perhaps specialized lymph structures which provide protection from infection although hand operations are also usually of short duration.

Some other areas or procedures are not so easily classified, but I believe that any surgery where implants are used, especially large implants such as total hip replacement, constitutes higher risk surgery with respect to post-operative infection. I am certain that there are procedures within other surgical specialties which have similar high risks

especially where implants are used. Among these procedures which do not involve implants, joint reconstruction, long operative procedures or those attended with hematoma formation also must be considered high risk.

However, most of these are subjective impressions and not based on facts or well controlled studies just as the importance of "laminar flow" remains to be established. At this time, there is little to recommend that all operating rooms be converted to laminar flow until more data are available. It must be remembered that a contaminated object inappropriately placed near the open wound in a high-velocity flow could potentially increase contamination and that the practical effectiveness of these systems during actual or simulated procedures very much needs to be investigated. This must be done for different types of procedures where the personnel and light arrangements are different. However, if a hospital is planning a new addition with new operating rooms, laminar flow is something to consider. I agree that any reasonable measure should be taken to minimize the risk of infection and improve the operating environment, but I differ from Dr. Leinbach in that justification is necessary to keep the spiraling medical costs within reason. I would like to point out once again how effective the use of prophylactic antibiotics and other control measures outlined seem to have been in minimizing the incidence of post operative latent infection in total hip surgery.

Dr. Leinbach:

I have a comment and since there has been a reference to me, I would like to say that if cement is approved, it will cost the United States government \$30 million in the first year for hospital care, rehabilitation, etc., on Medicare alone. There will be roughly 10,000 hip replacements at a minimum cost of \$3,000/operation. Infected cases, double the cost.

Mr. Agnew:

I must disagree respectfully with Dr. Amstutz. I think that laminar flow will save money, not cost money. In one of the speeches yesterday, it was brought out that we are spending a couple billion dollars a year taking care of patients who get infections. Another statistic I have heard is that every day the patient stays in the hospital increases his risk of infection by 1%. This has got to be a burden on the hospital and a burden on the taxpayer and a burden on everybody. If we can avoid the infections that cause this, which laminar flow can do, not only in surgery but in the rest of the hospital, it will immeasurably reduce the cost of medical care. People will be able to leave the hospital sooner because they won't get something that they did not have when they got there. They

will get over what they had when they got there sooner. I think the figure was \$7,000 that it costs for each surgical infection. Two infections will pay for converting a hospital suite to a laminar flow, and it is good for the next 10 years.

Comment:

After 6 months of intensive literature research, I think the majority of opinion is that the endogenous organisms are mostly causing infections, and therefore, there is no real proof that the laminar flow devices are going to lower the infection rate appreciably.

Question:

Dr. Harter, since you were describing the methods you go through in getting the astronauts into the capsule, what were your reasons for choosing to use HEPA filter applications and other clean room techniques for keeping your people in a state of good health just prior to the launching? Did you have reasons for using clean room techniques, for isolating them and keeping them in good health?

Dr. Harter:

Yes, we felt that the installation of HEPA filters would tend to cut down on the chances for exposure to airborne infective agents. No one expected that filters would eliminate viral disease except to the extent that they filter out dust to which the viruses adhere. The program of health surveillance carried out here at Kennedy Space Center was not airtight because people do not live in an airtight world. When the subjects did leave the clean-room areas, we tried to get them to wear masks, but it was not always practical to do this. Therefore, our "reverse quarantine" program did have gaps in it and because of these gaps, one must accept the possibility that the success of the program could, to some degree, be based on chance. It is my own feeling that the use of clean room techniques is a vital component of a disease control program such as the one we employed prior to Apollo 14 and will continue to use in the future.

Mr. Sivinski:

All right, we will start the second round of questions. I guess, John, since you were first last time, we will let you be first again.

Dr. Ulrich:

Thank you, Jack. There is a series of questions here relating to organisms in the air, in the wound, and survival in relation to infections. It has been already amply stated by both Dr. Clark and Dr. Amstutz that we have to be concerned with all organisms in the air, even those of low pathogenicity that we commonly carry on the skin and in the gut. Any particular organism may act as a pathogen for any particular patient, and that we have to keep in mind. We should be concerned with all organisms even though many of these may be of very low virulence. You'll recall that Dr. Clark yesterday mentioned that he had six infections caused by Staphylococcus epidermidis, which we carry on our skin. It's a very low-grade pathogen. But once it causes an infection, it's just as dangerous as any other pathogen. We should be concerned with all organisms and their removal. There are questions also as to organisms in the wound, especially the German report of 51% of the cases having organisms in the wound in a turbulent system and none in a laminar flow. I've not seen, other than a popular report, exactly how this work was done. Something very similar was done in this country by John Burke in Boston who finds a very high percentage of his cases have organisms in the wound. The mere fact that you have an organism in the wound does not necessarily mean that you have an infection. This term infection is treated semantically different by different people. There are some microbiologists unfortunately who use the term infection to indicate simply the mere presence of an organism. I can't accept this particular definition of an infection. To me, an infection is the presence of an organism with tissue invasion and tissue response. If you want to accept this, then the mere presence of organisms is not an infection. I like to think of an infection as a balance; in one pan you have an organism that has all its factors, invasion, virulence, and so forth; and on the other pan you have the host's response, the tissue, the cell response, and serologic response. If the host has a better armament, his pan is going to be heavier and he's going to win. If the invading organism is better equipped to overcome the defense of the host, then you're going to have a true infection. It's not a simple thing of just having organisms present.

A question here on, "What is the recommended period of time that we should leave a surgery empty after infected cases?" It can be used immediately after a good cleanup. Cleanup procedures have been researched by a group in the American Public Health Association and have been published. The important aspect is mechanical removal, but proper use of germicidal detergent is a factor.

A question asking, "whether pseudomonas has been cultured from air in the operating room?" Yes, we have done it on occasion, rather uncommonly, however.

Dr. Whitfield:

Jack, I have a question here, "Please analyze the various types of units, the vertical, the horizontal, and the wall-less horizontal, and please classify them in accordance with Federal Standard 209a." The vertical room is Class 100 over the entire room; and really what we are talking about there is that the air does not pass more than one work location in the room. Work location is the thing that contaminates the air in laminar airflow systems. In other words, how many people did it pass?

Now in the horizontal laminar flow situation, for industrial use where you have a room some 50-60 ft long with a number of workers upstream of the points which you measure, a room will normally meet Class 10,000. This situation does not pertain to the surgical suite where you have one work location, namely, the operating room table and surgical team. The downstream total particle count in an average horizontal room will more likely be 5,000 particles per cubic foot than 10,000. Federal Standard 209a specifies that Class 100, Class 10,000 and Class 100,000 are operational particle count levels at the critical work site. These levels do not represent the air quality entering the clean room area. Certainly, if you have a good laminar flow system with the filters sealed properly, probably you will not be able to detect more than a particle or two per cubic foot, even with a good counter in the incoming air. So we are talking about a working situation for the laminar flow clean room.

And the third part of this question is concerning the performance of the wall-less horizontal flow type unit. Again, you start from the filter bank with Class 100 conditions; however, when you deviate from what I call a hard system which has side walls to guide the air and a balanced air exit wall, there is a slight degradation of control as you move away from the filter bank. This may not be all bad, because it may do the job you want to do; so I think you have to look at the situation to evaluate the performance of the wall-less horizontal units. As you move away from the filter bank there is always a tendency for the air to short-circuit but maybe for your particular requirement you can tolerate the degradation in control. Getting back to the question we discussed previously regarding how much control should be exercised in the surgical suite, I think you must investigate your requirements and use the proper device. This is very similar to what we faced in industry some 8 to 10 years ago, and we finally adopted the philosophy that many times it is more economical to go well beyond your requirements than it is to find what your exact requirements are, particularly if your requirements are constantly changing or difficult to define. It appears to me, as Dr. Ulrich and others have said about the infection situation, that it is continually varying with patient resistance and the type of infectious organisms present. It may be more economical to go to full control than to try to ascertain an exact level required for a given set of conditions.

Dr. Leinbach:

I have a question from Dr. Harold Hansen (The Hospital Center at Orange, New Jersey); he says, "Can we come to a concrete conclusion regarding the virtue of space suits versus hoods and exhaust systems?" Well, I suggest a combination of hood and gown will cool the body to a comfortable level, and will also remove the fallout and the epidermal scales by suction. For example, the Charnley gown does not have fitting shoulders. This permits passage of air over the body into the exhaust system. I tend to support the higher temperature in the room (70°-75°F). First of all, because I'm perhaps a slower operator than Dr. Bechtol and I need that extra 20 min that I can get from the cement curing more rapidly. I am not uncomfortable. If I have an adequate exhaust system, such as a modification of a Charnley or any of the Charnley combination hood and gown, I am comfortable at 75°. One of the reasons I moved to Florida is that I was never warm anywhere else. So I like a temperature of 75°. Someone else mentioned this, about the difference in people's workability in different temperatures and that the exhaust system gives comfort to the operating team, which again Dr. Bechtol asked me to emphasize. So the exhaust system I think, at least the combination of the hood and gown, will cool the body, and I think we can't come to any concrete conclusions for everyone, but I'm more comfortable in it and that's enough conclusion for me.

Dr. Hansen's second question is, "Are there any concepts of localized laminar airflow in which a fairly portable unit, comparable to the bench models used in industry, have been devised?" Well, I'm going to ask Claude Marsh to answer that, but I'll ask one thing. Have any of you ever worked on a bench? I visited the Minneapolis Honeywell Plant in St. Petersburg, and sat at a bench. I learned that the airflow depends on the size of the object you handle. If you're using a small object, you have a different situation than a large one; if you're working your hands horizontally you need the horizontal flow; if you're working your hands vertically you need the vertical flow. I'm trying to learn from the industrial workers and until you put yourself into a situation, you never know why a truck driver gets a backache until you drive his truck. What about it Claude, can you answer this question about the portable units?

Mr. Marsh:

This relates to controlling, say, only the critical surgical site as opposed to controlling the entire room. There have been some things done; there have been some reports in the literature and I think the various companies making the laminar flow devices have at one time or another probably manufactured or used localized control devices for controlling smaller areas.

The smallest area control that I know of is what Dr. Beck at Guthrie Clinic has played around with for a number of years, just a 1 ft diameter ring to control the area right around the wound site. Dr. Leinbach has been thinking in terms of something he can transport with him that would control just the surgical table and maybe the team just around the table. A number of these kind of devices are available and could be adapted. I think this approach to the situation is definitely a compromise in order to achieve portability, yet at the same time achieve some local control. I don't think these units will replace or achieve equal results with the total room. It is possible to control a very small area or scale it up as large as possible. It's a matter of how much do you want to control and what are the factors for consideration. Dr. Clark in his heart room controlled only part of the entire room for economic reasons. Most of the room-within-a-room systems attempt to control, in the case of hip surgery, approximately a 10-ft square area, because that is felt to be adequate.

Dr. Leinbach:

Dr. Hansen has another question; he says, "In view of the apparent fact that turbulence is going to take place over the operative area, is there demonstrable proof that vertical or horizontal airflow is more efficient at this point?" Now, this is semantics; this is a loaded question, for the simple reason that what is demonstrable proof? I don't want to go on record for this in particular, but there are many variables to decide how you can demonstrate that turbulence is taking place over the operating area or prove that vertical or horizontal airflow is more efficient. I can only quote from, for example, a paper by Louis L. Corriell, "Use of Laminar Flow in Surgery." I've just asked my colleague on the right whether this man is acceptable as an authority, from the Institute of Medical Research in Camden, New Jersey, Department of Pediatrics, School of Medicine, University of Pennsylvania. "The theoretical objection to horizontal flow in the operating room is that a cone of contaminated air extends across the room downstream from every occupant in the room. This makes it difficult to keep the patient in freshly filtered air." This is a statement from a man who supposedly is an authority. I would say, how can you control anything in an operating room with four people moving around? One of the reasons is that if my assistant walks around me, he either steps on my exhaust tube or he twists up his own tube and then the both of us are asphyxiated. So we have a blocked out area marked on the floor in which we remain. My assistant on the opposite side is not allowed to lean over the table. Now, these are variables that we can control. You saw the picture from Charnley's operating room yesterday. It looked like a huddle of a football team. How can you choose vertical or horizontal flow? I don't think anybody has the answer to this. Does laminar airflow produce any appreciable drying of the operating wound? Have you worked in laminar airflow? You can have wet hands and walk in, wait for your gown, and you don't have to dry your hands. It can do the same thing to the wound.

If the air speed is rather rapid, it'll create an evaporative situation so that a viscous will even change its position by drying out. What about the operating room with a light above? I don't have a light above, but dehydration depends again on how much hydration you use. Every 5 or 10 min I irrigate my area with a solution of neomycin and bacitracin and Ringers solution. Before the field becomes too dry, we moisten it.

Mr. Marsh:

I would like to make a statement about crossflow and downflow, and maybe open some additional discussion. What I see personally being said here, is that in neither case is it possible to guarantee that there will not be upstream sources. You can identify in this huddle sources upstream, whether the flow is vertical or horizontal, and then it's a question of evaluating the potential of these sources and the frequency of them. Beyond that one must understand what is the effect of occasional upstream blockage of the air in a laminar flow system. This involves an understanding of what happens in a turbulent region. You go from what is very easy to draw on paper, nice straight-line flow which seems to be easy to understand to a situation behind obstructions which is extremely difficult to understand, and extremely difficult to describe. There have been many attempts already in this conference to describe these turbulent regions. Dr. Whitfield has shown that the flushing rate in the downstream turbulence is a matter of a few seconds as opposed to maybe a fraction of a second, depending on how small an area you want to consider. But, it is important to realize that in these downstream turbulences there is a very high flushing rate and you can go back to the physics of turbulent flow. Because of this very high flushing rate obstructions may not be a problem. In addition, the source of contamination that can enter these turbulences can also be limited. I'd like to state for the record that I don't think you can guarantee in either case, downflow or crossflow, the elimination of the possibility of blockage. If you really look at the situation very closely, you can see that there is very little difference in the frequency and amount of blockage in either configuration.

Professor Buchberg:

To continue the discussion of the use of a portable sterile air supply for local control it is important to point out that the boundaries of the sterile field downstream from the plane of issue is not determined by an extension of the entry plane. Entrainment of room air occurs at all of the boundaries and turbulent diffusion causes mixing of the entrained air into the sterile zone as you proceed downstream, limiting the region of sterile air. My friends at Sandia tell me that a useful "rule of thumb" is

to construct a cone or pyramid on the jet entry plane in the downstream direction such that the sides make about a 45-degree angle with the base. The region of the cone or pyramid should then be free of entrained contamination. This usually requires that the portable supply must be located quite close to the space being purged. Undoubtedly, there are applications where small portable sterile air supplies, properly deployed, may be useful. Cook and Boyd (1971) have recently reported on the use of a portable cabinet supply with an entry plane of about 15 x 36 in. in a surgery.

Mr. Agnew:

I don't disagree with the drawing that was just put there, but since a wall-less system has been presented, I would like to point out the difference between a completely wall-less system and one with air deflectors on each side. The reason why a stream of air moving away from the plenum will pull dead air from the sides into it, has been ascribed to Venturi effect or an aspiration effect, and these jets of air or liquid moving in a laminar fashion, can pull surrounding liquid or surrounding air into that stream. There are boat bailing systems that make use of this principle. You can bail a boat with a garden hose if you have the right kind of a T fitting. It would pull all the water out of the boat. In the wall-less system with air deflectors, we have a different situation. We have an essentially square room; it can be slightly rectangular. If we put this jet of air in that room, and we induce an opposing flow, we create a different situation. If the opposing flows are at the same rate as the outgoing flow, or nearly so, they cancel each other out. To prevent the short-circuiting that Mr. Whitfield referred to, we created a high-velocity hook of air here that acts as an air curtain. We have short-circuiting around the hook, but the velocity for the curtain and the rest of the 10,000 ft goes clear across the room. Now, I have two other things to say about that. We've had this system on display around the country for the last year; it will be in the Mid-Atlantic Health Congress in Atlantic City, this coming week. This flow goes for nearly 30 ft. It loses some of it from its hooks but you can go across the aisle and feel it. But we get entrainment just as the diagram that you saw before, because we don't have any way of creating an opposing flow. All this system does is recycle the air that's already in the room. By throwing out a column of air 10 ft wide across the room, we're producing over 500 air changes in the operating field and nearly 200 in the room as a whole, in an 18-ft square surgery. This flow will shorten and it will slow down under one condition, if the room is very old fashioned (to cite an extreme example, a 50-year-old surgery that is only 14 ft wide). This system is nearly 10-1/2; the opposing flows are faster than the outgoing. They were losing that way. We're getting, if anything, a mixing of our Class 100 zone into the return air stream. We're losing velocity and it won't go clear

across the room at 125 ft/min. I just wanted to take the opportunity to tell you that there are many advancements in the state of an art possible and urge you to keep an open mind, because we're going to find out a lot more things as we go along. The Federal Standard set up guidelines for this after it had been in effect for a very short space of time, because they wanted to transfer the knowledge in an orderly way to the Defense program. It served a very useful purpose. We had one change; we'll no doubt put out additional changes. We're able to treat air because of this discovery of Mr. Whitfield's for benefits that none of us have seen yet.

Dr. Castles:
(Midwest Research Institute, Kansas City)

How important are nonviable particles in wounds?

Dr. Ulrich:

They may be bad, and they may be good. In a conventional surgery, I think particles are a good thing, especially lint particles. Bacteria are normally negatively charged, and they'll attach to other particles, in fact. Most bacteria ride particles of one sort or another as evidenced by the many studies using Anderson samplers. So if you have particles of a larger size that bacteria can attach to, they certainly can be trapped by the filters much more readily. We carried out a 3-1/2 year study in a turbulent flow system that indicated it was better to recycle air within the surgery, adding only a certain percentage of air, usually about 15 to 20% to make up losses. We were able to keep the air cleaner by recycling than by bringing in fresh air, tempering it and throwing it away. This related very well with particle size. The reason is that the average particle size generated in a surgery is larger than the average particle size in fresh air. As a result, it's easier to trap in filters. There's one other thing I might say here about exhausts related to turbulent systems and not laminar flow. Blowers in England has shown that pickups 4 ft from the floor are more efficient than those at base line. Our results indicate he's right. You get a lower particle count by keeping the exhaust 4 ft up rather than at base-board level.

Mr. Sivinski:

A room like this auditorium?

Dr. Ulrich:

Yes.

Mr. Sivinski:

Unfortunately, we've run out of time. There are many questions yet--good questions--which have not been answered, and we simply have not had the time for them. What I'd like to do is review what we initially stated our purpose to be and how well we achieved it.

At the beginning I said that we would review the basics of clean room technology and try to determine what the state of the art was, and I think we did that fairly well.

Second, we wanted to examine the current needs and problems associated with the hospital surgery suite environment, and we've heard quite a bit about that, particularly from the surgeons involved.

Third, we wanted to identify, if possible, the areas where reliable data exist and to establish guidelines for obtaining the environment that a particular person desires and to help you identify just what kind of environment is needed. I think we started that very well, and we're going to continue it.

Throughout the day and a half I've heard various people ask questions like, "Based on principles only, which should I choose, vertical or horizontal laminar flow?" This bothers me because the principle is no different in either a horizontal or a vertical room. Only the application of the principle is different. The principle of so-called laminar flow clean room technology is sweeping the area clean all the time instead of trying to clean it up by housekeeping or some other way. Laminar flow systems are very simple, and frequently people try to make more out of them than they should; they think there's black magic to it. What you try to do is sweep a room out with sterile air and that's the environment you work in. That's really the important thing to remember. How you should sweep a room, vertically or horizontally, depends on your particular application. What we really need is a way to intelligently determine whether you need a laminar flow system or not, and if you do need one, how to choose the system best suited for your needs.

Those of us participating in this program recognize that these are very important problems and propose to pursue them in the following ways.

First, the proceedings of this meeting will be published. Second, steps will be taken to revise Federal Standard 209a. NASA has produced an addendum to 209a which includes some microbiology. This was done by Jack Foulks in the NASA Headquarters Bio-Sciences Group in Interplanetary Quarantine, and if Willis and I remember correctly, it was a pretty good piece of work. Midwest Research Institute is going to send this document to all who

have come here for commentary as to whether this document might be a starting point for building a system of guidelines to help understand your clean air problems. I think it's probably not bad; it deals with the microbiology of laminar flow rooms, as far as determining bioburden on spacecraft, but that's only a trivial detail of application. The important thing is, how does one go about evaluating and solving his problem and what are the important areas, whether it's a patient or a spacecraft. To tell you further about NASA plans and MRI's role in this endeavor is Mr. Jim Richards of NASA Headquarters.

Mr. Richards:

There are three brief things I would like to say here in wrapping up.

First of all to reiterate about the Proceedings, we will publish a Proceedings; we will try to get this done within a period of about 60 days. I think the MRI people are going to have fun putting this together, but we will get Proceedings out to all the attendees.

The second thing is that we have over the last day and a half, I think, seen some areas where perhaps some of the work that we have done in NASA concerning clean rooms and clean room technology might be of assistance to the people who are now trying to apply the techniques in medicine. We do intend to pursue this and see if in fact we can assist in some of these areas, so we will be in touch with many of you to pursue some of these problem areas.

Third, I think the participants here at the symposium have done an outstanding job. I think that you join me in expressing our appreciation for their participation. Thank you very much.

PARTICIPANTS AND ATTENDEES

BIOGRAPHICAL SKETCHES OF PARTICIPANTS



Harlan C. Amstutz, Professor and Chief, Division of Orthopaedics, UCLA School of Medicine, Los Angeles, California; Physician/Consultant in Orthopaedic Surgery, Veterans Administration Center, Los Angeles; and Associate Director, Institute of Chronic Disease and Rehabilitation, UCLA.

Dr. Amstutz holds a B.A. (1953) and an M.D. (1956) from the University of California at Los Angeles. Dr. Amstutz completed an internship at Los Angeles County General Hospital (1956-57); a residency in surgery at the UCLA Medical Center Hospital (1957-58); and an orthopaedic residency at the Hospital for Special Surgery (1958-61). He received post-graduate education in London, England, as an Honorary Registrar at the Royal National Orthopaedic Hospital, London, England (1963-64), and a Research Assistant in the Institute of Orthopaedics.

Besides several academic appointments in the area of orthopaedic surgery, Dr. Amstutz has served as the Director of Bioengineering at the Hospital for Special Surgery and as a Lecturer in Bioengineering at the Polytechnic Institute of Brooklyn.

Dr. Amstutz is a member of the Academy of Orthopaedic Surgeons, Orthopaedic Research Society, American Society for Testing and Materials, the American College of Surgeons, American Medical Association and the Association of Bone and Joint Surgeons. He has served on several committees on orthopaedics for the National Academy of Science and is currently on the executive committee of the American Academy of Orthopaedic Surgeons. In 1970, Dr. Amstutz served as chairman of the Gordon Research Conference on the Science and Technology of Biomaterials and was awarded an ABC Traveling Fellowship.

Charles O. Bechtol, Professor of Surgery, Department of Orthopaedic Surgery, and Director of Courses for Physicians in Upper and Lower Extremity Prosthetics, University of California School of Medicine, Los Angeles.



Dr. Bechtol received his B.S. (1934) from Stanford University and M.D. (1940) from Stanford Medical School, Palo Alto, California.

Dr. Bechtol completed his internships at the Stanford Hospital (1939-40) and Highland Hospital (1940-41). His surgery residency was completed at Highland Hospital (1941-42) and his orthopaedic surgery residencies were completed at Wisconsin General Hospital (1942-44) and the Samuel Merritt Hospital, Oakland (1944-45). Between 1946-51, Dr. Bechtol was a clinical instructor in Orthopaedic Surgery and an Assistant Clinical Professor (1951-54) at the University of California, San Francisco. He was an Associate Professor of Surgery (orthopaedics) and Chief of the Division of Orthopaedic Surgery at the Yale Medical School (1954-57). He accepted his present position in 1957.

Dr. Bechtol is a member of 21 societies, which include the International Society of Orthopaedic Surgery and Traumatology, the American Academy of Orthopaedic Surgeons and the American Orthotics and Prosthetics Association. He has held several government appointments and has published several texts on hip-prosthesis.



Harry Buchberg, Professor of Engineering and Applied Science, Energy and Kinetics Department, School of Engineering and Applied Science, University of California, Los Angeles.

Professor Buchberg holds a B.S. (M.E., 1941) from the University of California, Berkeley, and an M.S. (Engineering, 1954) from the University of California, Los Angeles.

Professor Buchberg was a research engineer (1941-45), Lockheed Aircraft Corporation; an engineering designer (1945-47); a research engineer (1947-55); Associate Professor of Engineering (1955); and Professor of Engineering, University of California, Los Angeles.

Professor Buchberg is Chairman, Steering Committee on Bioengineering (1970-present), UCLA; a member of the committee on Basic Research [ARO(D)] National Research Council, National Academy of Science (1966-69); Editor (1959), Proceedings of Conference on Designing the Indoor Environment, UCLA.

Professor Buchberg is twice a recipient of a Fulbright Award (1952, 1971); he is a member of several societies including American Society of Mechanical Engineers, American Society of Electrical Engineers and American Society of Heating, Refrigeration, and Air Conditioning Engineering. He is the author of several publications related to control of hospital environments.

Richard E. Clark, Assistant Professor of Surgery and Biomedical Engineer, Division of Cardiothoracic Surgery, Schools of Medicine and Engineering and Applied Science, Washington University, St. Louis, Missouri.



Dr. Clark holds a B.S.E. in Chemical Engineering (1956), Princeton University; an M.D. (1960) from Cornell University; and an M.S. in Surgery (1962) from the Graduate School of Arts and Sciences, University of Virginia.

Dr. Clark completed both his internship and residency in the Department of Surgery, University of Virginia Hospital from 1960-67. During 1967-69, he was Assistant Chief in the Department of Thoracic and Cardiovascular Surgery and Director of Thoracic and Cardiovascular Surgical Research Laboratory, National Naval Medical Center, Bethesda, Maryland. In 1969, he accepted his present position.

Dr. Clark is a member of 14 societies, among which are the American College of Surgeons, American Medical Association, American Society for Artificial Internal Organs and the Society of Engineering Science. He has been the recipient of several research fellowships and grant awards.

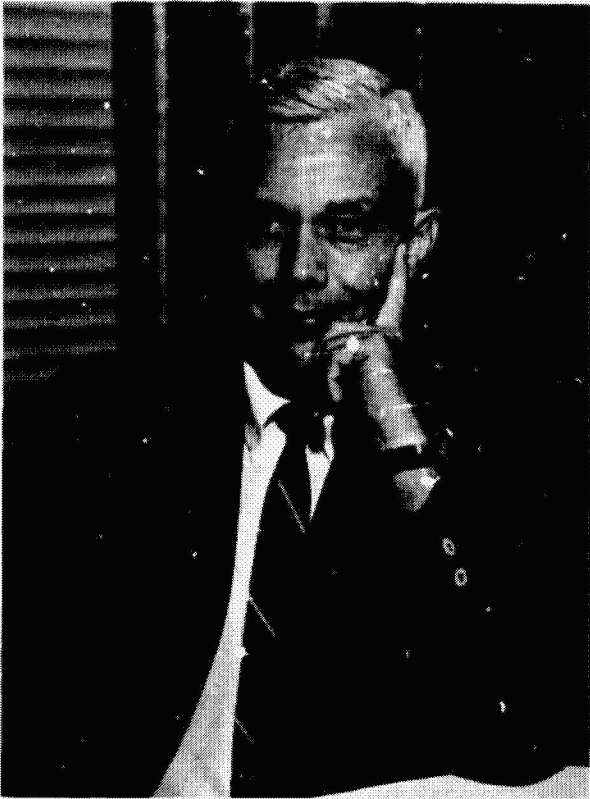

Alan C. Harter, Chief, Medical Services Office, John F. Kennedy Space Center, NASA, Kennedy Space Center, Florida.

Dr. Harter holds a B.A. (1949) in Economics from Williams College, an M.D. (1965) from the University of Buffalo, and an M.P.H. (1966) from the Harvard School of Public Health.

Dr. Harter practiced internal medicine in Lenox, Massachusetts; was an attending Physician and Associate in Cardiology at Pittsfield General and St. Luke's Hospitals, Pittsfield, Massachusetts; was a clinical instructor of Medicine, Pittsfield Affiliated Hospitals; and a Staff Internist at the Austin Riggs Psychiatric Center, Stockbridge, Massachusetts. Dr. Harter was Chief, Launch Site Medical Operations Branch, Manned Spacecraft Center, NASA, Houston, Texas, from 1966-70. In 1970, he assumed his present position as Chief, Medical Services Office, John F. Kennedy Space Center, NASA, Kennedy Space Center, Florida.

Dr. Harter is currently a Fellow in the American College of Preventive Medicine; an Adjunct Professor of Aerospace Medicine at the Florida Institute of Technology, Melbourne, Florida, a board member of the Florida East Coast Multiple Sclerosis Society and a member of the American Institute of Aeronautics and Astronautics and the Aerospace Medical Association.

Irwin S. Leinbach, Orthopaedic Surgeon (private practice) and Senior Consultant in Orthopaedics, Bay Pines Veterans Hospital, St. Petersburg, Florida. He also is a visiting professor, Law-Medicine, Stetson University College of Law, St. Petersburg.



Dr. Leinbach received his A.B. (1929) from Ursinus College, Collegeville, Pennsylvania; his M.D. (1935) from the University of Pennsylvania Medical School.

Dr. Leinbach served his internship at Reading Hospital (1934), his externship at the Hospital for Joint Diseases, New York (1934) and was an Assistant in the Department of Anatomy at Temple University Medical School (1935). He was an Assistant Orthopaedic Surgeon, Reading Hospital (1936-41); Chief Resident Orthopaedic Surgeon, American Hospital in Britain, Oxford, England (1942); and a Gibney Fellow in Orthopaedic Surgery, Hospital for Special Surgery, New York (1943). He was Chief, Orthopaedic Surgery (1943-45), Drew Field Station Hospital, Tanya, Florida, and has been in private practice in St. Petersburg since 1946.

Dr. Leinbach is active in several areas and associations. A selected few include Director, Cerebral Palsy Clinic, St. Petersburg; President's Committee for Rehabilitation of the Disabled; International Society for Orthopaedic Surgery and Traumatology; Swiss Society for Research in Osteosynthesis; and Yugoslav Association of Orthopaedics and Traumatic Surgery. He is a Fellow in many of the major medical associations as well as being a founding member of the Law-Science Academy and Foundation of America.

Among the honors Dr. Leinbach has received are the Eisenhower award for Service to the Handicapped, the Kennedy award for Service to the Handicapped; the AMA award for Meritorious Service (South Viet Nam) and the Arthritis Foundation National Award.



R. Claude Marsh, Director of Research and Development for Envirco, Division of Becton, Dickinson and Company, located in Albuquerque, New Mexico.

Mr. Marsh received B.S. degrees in Physics and Mathematics (1958) from the Pasadena College, Pasadena, California, after which he continued his course of study in the Graduate Physics Department of the University of New Mexico.

From 1959 to 1966, he was associated with the Sandia Laboratories in Albuquerque, New Mexico, as a Technical Staff Member. During this time, he performed laboratory research studies of airborne and liquid-borne monitoring techniques and instrumentation, and was intimately involved with the development of the laminar airflow clean room principle. In 1966, he accepted a position as Senior Engineer with Texas Instruments in Dallas, Texas, where he was responsible for design and installation of contamination control facilities for the manufacturing of thin-film microelectronic devices.

Mr. Marsh is the author of numerous articles and technical papers in the contamination control field. He served as Technical Advisor for the Federal Standard Working Group which wrote the first federally coordinated document for clean room standardization. He is a member and National Director of the American Association for Contamination Control, and a member of the American Society for Testing Materials.

Carl L. Nelson, Jr., Assistant Professor, Staff, Department of Orthopaedic Surgery, and Head, Section of Orthopaedic Research, the Cleveland Clinic Foundation, Cleveland Ohio.



Dr. Nelson holds a B.S. (1955) from Purdue University and an M.D. (1959) from the Indiana University School of Medicine.

Dr. Nelson completed a residency in internal medicine (1960-61) and was in General Practice in San Gabriel, California, from 1961-62. During 1962-63 he completed a residency in General Surgery at Los Angeles County General Hospital, and then in Orthopaedic Surgery (1963-66) at the Cleveland Clinic Foundation. He was Chief of the Department of Orthopaedic Surgery (1966-68) at Kenner Army Hospital, Fort Lee, Virginia; and was a Nuffield Scholar (1968-69), Nuffield Orthopaedic Center, University of Oxford, Oxford, England.

Dr. Nelson has received several awards including the Resident Award from the American Orthopaedic Association and the Nuffield Scholarship from the University of Oxford. He is a member of the American Medical Association, Orthopaedic Research Society, American Academy of Orthopaedic Surgeons, and is a Fellow in the American College of Surgeons.



J. Philip Nelson, Orthopaedic Surgeon,
St. Luke's Hospital, Denver, Colorado,
and Instructor of Orthopaedics.

Dr. Nelson received his B.A. (1957) Grinnell College, Grinnell, Iowa, and his M.D. (1961) Northwestern University.

Dr. Nelson completed his internship (1962-63) at King County Hospital, Seattle. He was an orthopaedic surgery resident (1963-66) at Mayo Clinic; practiced orthopaedic surgery (1966-68) in the U.S. Naval Hospital, Memphis; and completed his residency (1968-69) in orthopaedic surgery at Mayo Clinic. Dr. Nelson began the private practice of orthopaedic surgery (1969) and became an instructor of orthopaedic surgery (1970) at the University of Colorado.

Dr. Nelson belongs to the American Medical Society, Colorado Medical Society and Denver Medical Society. He is also a Diplomate of the American Board of Orthopaedic Surgery.

H. D. Sivinski, Manager, Planetary Quarantine Department, Sandia Laboratory, Albuquerque, New Mexico.



Mr. Sivinski received a B.Sc. (1957) in Mechanical Engineering from Iowa State University, Ames, Iowa. He joined Sandia Laboratory in 1957 where he served as a staff member until 1960; as a Supervisor, Facility Planning Section (1960-64); Supervisor, Advanced Systems Research Department (1964-66); and was appointed to his present position in 1966.

Mr. Sivinski has received several honors which include: National Chairman for a joint 3-day AEC/NASA Symposium on "Instrumentation and Automation for Contamination Control" (1967), and Membership on the Spacecraft Sterilization Advisory Subcommittee to NASA on Systems Analysis and Mathematical Modeling (1967-Present). He is also a member and past chairman (1954-55) of the American Society of Mechanical Engineers and holds memberships in the American Institute of Aeronautics and Astronautics, and the American Association for Contamination Control.

Mr. Sivinski's activities in the contamination control area include: Chairman, "Man in Space" Colloquium, New Mexico Academy of Science (1961); State Convention, New Mexico Society of Medical Technicians (1963); Joint Regional Meeting, American Society of Mechanical Engineers, American Society of Industrial Engineers, and American Society for Quality Control, Albuquerque, (1964); New Mexico Business and Manufacturers Association (1966); Instrument Society, Albuquerque (1966); Sandia Research Colloquium, "Planetary Quarantine Program" (1967); UNM Naval Reserve Research Group, "Planetary Quarantine Program" (1967); "Techniques for the Limitation of Biological Loading of Spacecraft Before Sterilization," COSPAR, London, England (1967); "Laminar Flow Clean Room Technology," presented to American Academy of Pediatrics Committee on Fetus and Newborn, Washington, D. C. (1967); "Contamination Control Principles," NASA-SP-5045, U.S. Government Printing Office (1967); "The Use of Laminar Airflow in Contamination Control," Chapter in Methods in Microbiology, Academic Press, London (in press).



John A. Ulrich, Ph.D., Professor, School of Medicine, University of New Mexico, Albuquerque, New Mexico.

Dr. Ulrich received his B.S. (1938) from St. Thomas College, St. Paul, Minnesota, and his Ph.D. in Bacteriology (1947) from the University of Minnesota. He completed post-doctoral courses in Medical Mycology and Tuberculosis (1949) at the Communicable Disease Center, Atlanta, Georgia.

Dr. Ulrich's professional experience includes: Research Assistant, Teaching Assistant, and Instructor in Bacteriology, University of Minnesota (1941-45); Research Associate, Hormel Institute, Austin, Minnesota (1945-49); Instructor (1949-55), Assistant Professor (1955-66), Mayo Foundation; Associate Professor, Mayo Graduate School of Medicine (1966-Present); Associate Professor, University of Minnesota (1966-Present); and Professor, School of Medicine, University of New Mexico (1969-Present).

Dr. Ulrich has had numerous honors including: Member (1961-69) and Chairman (1966-69), Executive Board for Certification in Public Health and Medical Laboratory Mycology, American Board of Microbiology; Member, American Public Health Association, Laboratory Section Committee on Microbial Contamination of Surfaces (1963-Present); Member, American Public Health Association, Hospital and Facilities Committee (1962-Present); Member, Spacecraft Sterilization Advisory Committee, AIBS-NASA (1965-68); Member (1967-70) and Chairman (1968-69), Communicable Disease Prevention Study Section, Communicable Disease Center; and Member, Planetary Quarantine Advisory Committee, AIBS-NASA (1968-Present).

Dr. Ulrich belongs to many professional societies and has over 70 publications and papers covering his professional activities. His work in post-operative wound infections and bacterial skin populations originated back in 1960.

John G. Whitcomb, Staff Surgeon, General and Cardiovascular Surgery, Lovelace Clinic and Foundation, Albuquerque, New Mexico.



Dr. Whitcomb received his B.S. (1947) from the University of Michigan; M.D. (1951) from the University of Cincinnati; and M.S. (Surgery, 1956) from the University of Michigan.

Dr. Whitcomb completed his residency (1952-59) and served on the staff (1959-61) at the Henry Ford Hospital in Detroit. He assumed his present position at Lovelace Clinic and Foundation in 1961.

Dr. Whitcomb is a member of the staff at several Albuquerque hospitals, which includes Bataan Memorial Hospital, where much of his pioneer work using laminar airflow was accomplished. He is a member of the American Medical Association and the American College of Chest Physicians, to name a few.

Among Dr. Whitcomb's honors are Past-President, American Cancer Society, New Mexico Division (1968-70); Chairman, Hospital Committee, American Association for Contamination Control, National (1969-present); and Vice-Chairman, Executive Committee, Education Board, Bataan-Lovelace Medical Center.



Willis J. Whitfield, Division Supervisor,
Applied Science Division, Sandia Labor-
atories, Albuquerque, New Mexico.

Dr. Whitfield holds a B.S. (1952) in Physics and Mathematics from Hardin-Simmons University, completed graduate work in Physics at George Washington University (1953), the University of New Mexico (1959) and received his D.Sc. (1970) from Hardin-Simmons University.

Dr. Whitfield's experience includes Division Head, Naval Research Laboratories (1952-54); Staff Member, Research and Development, Sandia Laboratories (1954-66); and Division Supervisor, Applied Science Division (1966-present).

Dr. Whitfield has served as Chairman of Surface Monitoring Committee of the American Society for Testing Materials, F-1 Section (1963-64); was a member of the Society for Non-Destructive Testing (1961-64); is a member of the American Association for Contamination Control (AACC); and is presently Chairman of the Particle Counting Committee for the National AACC Organization. He was awarded the Individual Scientific Technical Achievement Award by the American Association for Contamination Control (May 1969); the Holly Medal for the laminar flow clean room principle by the American Society of Mechanical Engineers (1969); and the Research Achievement Citation by the European Contamination Control Foundation in Stuttgart, Germany (1970).

LIST OF ATTENDEES

SYMPOSIUM
ON
CLEAN ROOM TECHNOLOGY IN SURGERY SUITES

John F. Kennedy Space Center, Florida
21 and 22 May 1971

Ackerman, Elliot A., M.D.
Chief of Orthopedics
Atlanta V.A. Hospital
Clairmont Road
Atlanta, Georgia

Agnew, Boyd
President
Agnew-Higgins, Inc.
P.O. Box 857
Garden Grove, California 92642

Amstutz, Harlan C., M.D.
Professor and Chief
Orthopedic Surgery
UCLA College of Medicine
Los Angeles, California 90024

Bailen, Burton
Presbyterian Hospital
622 West 168th Street
New York, New York 10032

Baisier, Walter P., M.D.
Orthopedist
Springfield Clinic
1025 South 7th Street
Springfield, Illinois 62703

Bechtol, Charles O., M.D.
Orthopedic Surgeon
7080 Hollywood Boulevard
Hollywood, California

Bemberg, Kurt F., P.E.
Chief Engineer
Barnes and Associated Hospitals
Barnes Hospital Plaza
St. Louis, Missouri 63110

Bermann, Pedro F., M.D.
St. Joseph's Hospital
Patterson, New Jersey

Biondi, Frank J.
Chairman, Board of Trustees
The Hospital Center at Orange
Orange, New Jersey 07051

Bishop, Donald
Manager, Clean Room Systems Sales
American Air Filter
215 Central Avenue
Louisville, Kentucky

Borg, Janet L., R.N.
Operating Room and Recovery Supervisor
Baptist Hospital of Miami, Inc.
8900 Southwest 88th Street
Miami, Florida

Buchberg, Harry
Professor of Engineering and Applied Science
Department of Engineering, UCLA
5531 Boelter Hall
Los Angeles, California 90024

Callahan, General D.F., L.L.D.
Deputy Director, Administration
Kennedy Space Center
Kennedy Space Center, Florida 32899

Carson, Donald
Medical Consultant
Box 263
Evergreen, Colorado 80439

Castles, Thomas R., Ph.D.
Director, Biomedical Application Team
Midwest Research Institute
425 Volker Boulevard
Kansas City, Missouri 64110

Clark, Richard E., M.D.
Assistant Professor of Surgery
Washington University School of Medicine
4960 Audubon
St. Louis, Missouri 63110

DuGoff, Lee
Technology Utilization Office
Kennedy Space Center
Mail Code AD-PAT
Kennedy Space Center, Florida 32899

Dunn, Harold K., M.D.
Asst. Professor of Orthopedic Surgery
University of Utah
50 North Med Boulevard
Salt Lake City, Utah 84112

Edge, Donald R.
Architect
Powell-Edge Partnership, Architects
Phipps Plaza Building
Palm Beach, Florida 33480

Edwards, John
Distributor
Depuy, Inc.
P.O. Box 701
Maitland, Florida

Errera, Mrs. Dorothy W., R.N.
Operating Room Consultant
Hospital Topics
5773 Southwest 31st Street
Miami, Florida 33155

Ferguson, Carol
Technology Utilization Office
Kennedy Space Center
Mail Code AD-PAT
Kennedy Space Center, Florida 32899

Fitzgerald, Robert H., M.D.
Resident Orthopedic Surgery
Mayo Clinic
200 First Street, Southwest
Rochester, Minnesota 55901

Fremstad, Charles
Director of Surgical Services
Rochester Methodist Hospital
201 West Center Street
Rochester, Minnesota 55901

Gelvin, Dennis
Sales Manager
Agnew-Higgins, Inc.
P.O. Box 857
Garden Grove, California 92642

Goddard, Kenneth R.
Bio-Engineering and Hospital Consultant
P.O. Box 3783 Station "B"
Savannah, Georgia 31404

Hall, Marshall F., M.D.
Orthopedic Surgeon
Suite 405
Dadeland Medical Building
7400 North Kendall Drive
Miami, Florida 33156

Hansen, Harold T., M.D.
Chief, Orthopedic Surgery
New Jersey Orthopedic Hospital Unit
The Hospital Center at Orange
188 South Essex Avenue
Orange, New Jersey 07051

Harrell, James O.
Technology Utilization Officer
Kennedy Space Center
Mail Code AD-PAT
Kennedy Space Center, Florida 32899

Harter, A. C., M.D.
Chief of Medical Services
Kennedy Space Center
Kennedy Space Center, Florida 32899

Harvey, Colleen K.
Associate Director, Operating Rooms
Indiana Medical Center
1100 West Michigan Street
Indianapolis, Indiana 46202

Hess, Wallace E., M.D.
Orthopedic Surgeon
333 South 9th Avenue East
Salt Lake City, Utah 84103

Irons, Alexander
Senior Research Scientist
Jet Propulsion Laboratory
Pasadena, California

Kao, Jim
Engineering Design Branch
National Institute of Health
Bethesda, Maryland

Ketelhohn, Alan F., M.D.
Orthopedic Department
St. Joseph Hospital, Denver Clinic
701 East Colfax
Denver, Colorado

Knight, Francis J.
Director of Engineering
Codman and Shurtleff, Inc.
Pacella Drive
Randolf, Massachusetts 02368

Leinbach, I. S., M.D.
Orthopedic Surgeon
631 6th Avenue South
St. Petersburg, Florida 33701

Marks, Thomas, M.D.
Atlanta Orthopedic Clinic
Georgia Baptist Hospital
Suite 545
340 Boulevard Northeast
Atlanta, Georgia 30318

Marsh, Claude
Manager, Project and Development
Envirco
Albuquerque, New Mexico

Mosley, Ray
Consulting Engineer
Bay Front Medical Center
5143 3rd Avenue South
St. Petersburg, Florida

Nelson, Carl L., M.D.
Orthopedic Surgeon
Cleveland Clinic Foundation
2020 East 93rd Street
Cleveland, Ohio 44106

Nelson, J. Phillip, M.D.
Orthopedic Surgeon
St. Luke's Hospital
1707 East 18th Avenue
Denver, Colorado 80218

Pederson, Paul D., Jr.
SCI-MED
Litton Industries
103010 County Road 6
Minneapolis, Minnesota 55427

Peers, Miss Jerry G.
Executive Director
Association of Operating Room Nurses
8085 East Prentice Avenue
Englewood, Colorado 80110

Pittman, Jerry R.
Manager, Engineering and Sales (Med)
Moore and Hanks, Company
9702 East Rush Street
South El Monte, California

Post, Jerry
Manager, Environmental Systems
Moore and Hanks, Company
9702 East Rush Street
South El Monte, California

Puleo, John R.
Research Microbiologist
Spacecraft Bioassay Unit
U.S. Public Health Service
P.O. Drawer Y
Cape Canaveral, Florida 32920

Ray, Dwain C.
Richards Manufacturing Company
1450 Brooks Road
Memphis, Tennessee 38116

Richards, James T., Jr.
Chief, Technology Applications Branch
Office of Technology Utilization
NASA Headquarters
Code KT
Washington, D.C. 20546

Ritter, Merrill A., M.D.
Orthopedic Surgeon
Indiana University Medical Center
1100 West Michigan Street
Indianapolis, Indiana 46202

Sivinski, H. D.
Manager, Planetary Quarantine Dept.
Sandia Laboratories
Albuquerque, New Mexico 87115

Skeats, John M., M.D.
President, Medical Staff Board
The Hospital Center at Orange
188 South Essex Avenue
Orange, New Jersey 07051

Smith, Albert R., M.D.
Chairman, Department of Surgery
Grant Hospital
363 East Town Street
Columbus, Ohio 43215

Smith, Justin
Engineering Design Branch
National Institute of Health
Bethesda, Maryland

Snyder, Joseph E., M.D.
Assistant Vice-President
Presbyterian Hospital
622 West 168 Street
New York, New York 10032

Stacy, John E., Jr.
Assistant to the Vice President,
Technical Operations
Manager, Technology Utilization
Midwest Research Institute
425 Volker Boulevard
Kansas City, Missouri 64110

Stokes, Hope L. (Mrs.)
Director of Nursing
John F. Kennedy Memorial Hospital
P.O. Box 1489
Lake Worth, Florida

Stoner, Theodore, M.D.
Director of Anesthesia
Good Samaritan Hospital
3217 Clifton Avenue
Cincinnati, Ohio 45220

Sularz, Frank D.
General Manager
Envirocc
P.O. Box 6458
Albuquerque, New Mexico 87107

Swenson, Orvar, M.D.
Surgeon-in-Chief
Children's Memorial Hospital
2300 Children's Plaza
Chicago, Illinois 60614

Ulrich, John A., Ph.D.
Professor of Microbiology and Pathology
University of New Mexico Medical School
915 Standford, Northeast
Albuquerque, New Mexico 87106

Unfred, Robert
Plant Manager
St. Mary's Hospital
P. O. Box 1628
Grand Junction, Colorado 81501

Vinograd, S. P., M.D.
Director, Bioresearch Division
NASA Office of Life Sciences
NASA Headquarters
Washington, D.C.

Watson, William S.
Consultant, Operating Room Techniques
202 Park Road
Pittsford, New York 14534

Welch, Richard B., M.D.
Orthopedic Residency Program Staff
St. Mary's Hospital and Medical Center
4141 Geary Boulevard
San Francisco, California 94118

Weseli, Roger W.
Associate Administrator
Good Samaritan Hospital
3217 Clifton Avenue
Cincinnati, Ohio 45220

Whitfield, W. J., D.Sc.
Division Supervisor
Applied Science Division
Sandia Laboratories
Albuquerque, New Mexico 87115

Worrell, John, Ph.D., M.D.
Sandia Laboratories
Albuquerque, New Mexico 87115

Zak, George J.
Chief Engineer
Bay Front Medical Center
701 6th Street North
St. Petersburg, Florida

Zaro, Mike
Bio-Engineering and Hospital Consultant
P.O. Box 3783 Station "B"
Savannah, Georgia 31404

Zylstra, Donald
NASA Public Affairs Officer
Code K
Room 5032
Federal Office Building 6
NASA Headquarters
Washington, D.C.