

N72-28838

CR 115415

MSC-03978

LMSC-A984262D

JULY 15, 1971



CASE FILE COPY

LUNAR MISSION SAFETY AND RESCUE

PREPARED FOR
NATIONAL AERONAUTICS & SPACE ADMINISTRATION
MANNED SPACECRAFT CENTER HOUSTON, TEXAS
CONTRACT NAS 9-10969



OFFICE OF PUBLIC AFFAIRS

SF

OPEN



SSD

SPACE SYSTEMS DIVISION

ESCAPE/RESCUE ANALYSIS AND PLAN

LOCKHEED MISSILES & SPACE COMPANY
A GROUP DIVISION OF LOCKHEED AIRCRAFT CORPORATION
SPACE SYSTEMS DIVISION · SUNNYVALE, CALIFORNIA

MSC-03978
LMSC-A984262D
Revision 1

LUNAR MISSION SAFETY AND RESCUE
ESCAPE/RESCUE ANALYSIS AND PLAN

Prepared for
National Aeronautics and Space Administration
Manned Spacecraft Center
Houston, Texas 77058

Under
Contract NAS9-10969
MSC DRL-T-591
Line Item 4

LOCKHEED MISSILES & SPACE COMPANY
SPACE SYSTEMS DIVISION
P.O.Box 504 SUNNYVALE, CALIF. 94088

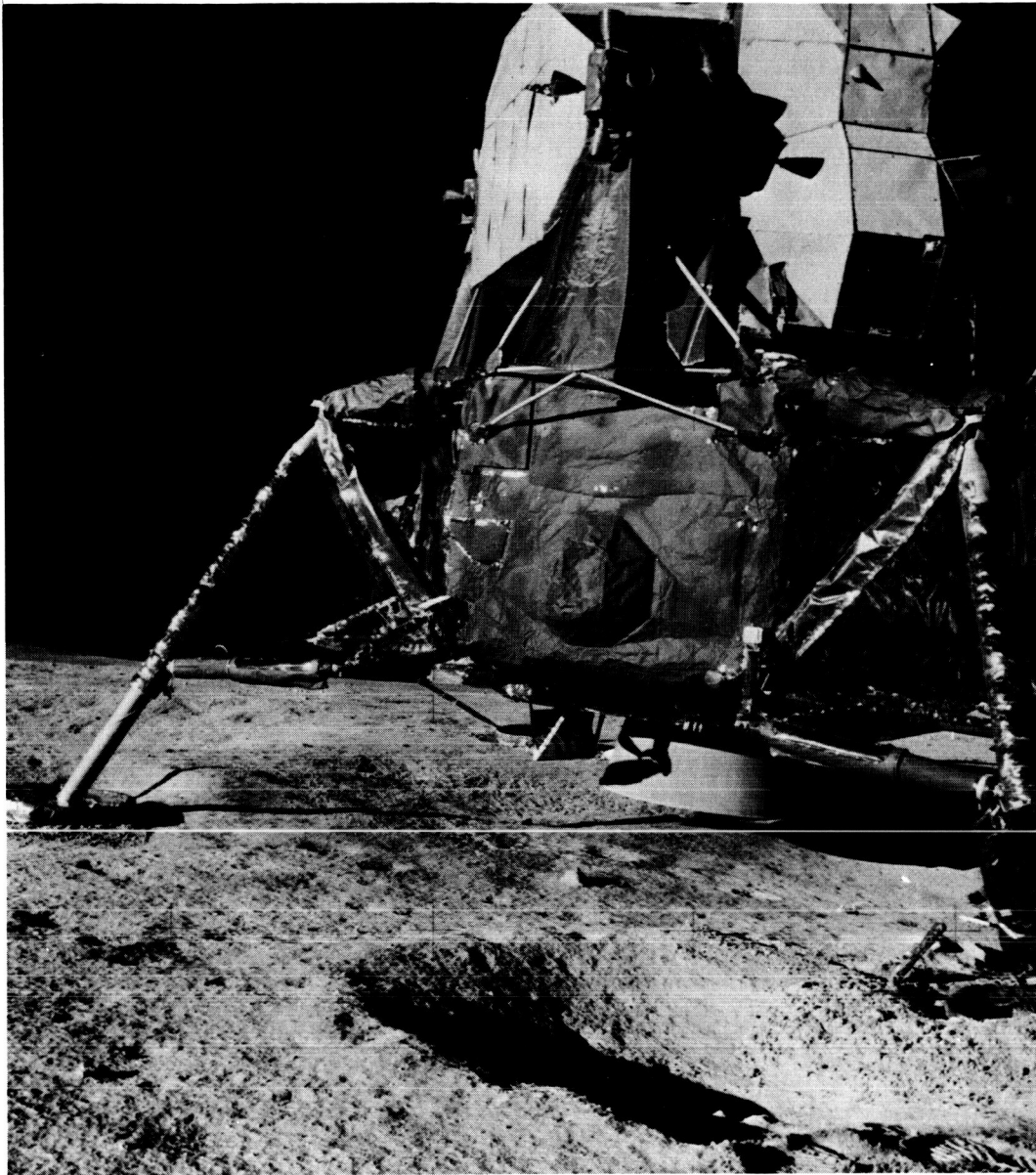

Lunar Surface Landing Hazards - Apollo 14 Mission

FOREWORD

This report was prepared by the Lockheed Missiles & Space Company, Sunnyvale, California, and presents a technical summary of results of the Lunar Mission Safety and Rescue Study performed for the National Aeronautics and Space Administration, Manned Spacecraft Center, under Contract NAS9-10969. This is one of the following four reports documenting the contract findings:

MSC-03975,	LMSC-A984262A	Lunar Mission Safety and Rescue - Executive Summary
MSC-03976,	LMSC-A984262B	Lunar Mission Safety and Rescue - Technical Summary
MSC-03977,	LMSC-A984262C	Lunar Mission Safety and Rescue - Hazards Analysis and Safety Requirements
MSC-03978,	LMSC-A984262D	Lunar Mission Safety and Rescue - Escape/Rescue Analysis and Plan

CONTENTS

Section		Page
	FOREWORD	iii
	GLOSSARY	xi
1	INTRODUCTION	1-1
	1.1 Scope and Objectives	1-1
	1.2 Approach	1-1
	1.3 Ground Rules	1-2
	1.4 Assumptions	1-3
2	LUNAR ARRIVAL/DEPARTURE OPERATIONS	2-1
	2.1 Situation Description	2-1
	2.1.1 Lunar Orbit Insertion	2-1
	2.1.2 Trajectory Velocity Vectors	2-2
	2.2 Lunar Arrival Operations	2-6
	2.2.1 Propulsion Malfunction	2-6
	2.2.1.1 Hyperbolic Trajectory	2-9
	2.2.1.2 Elliptical Orbit	2-10
	2.2.1.3 Elliptical Orbit Impact Trajectory - Propulsion Overburn	2-10
	2.2.2 Guidance System Failure	2-11
	2.2.2.1 Escape from Trajectories	2-11
	2.2.2.2 Escape/Rescue from Hyperbolic Trajectories	2-12
	2.3 Lunar Departure Operations	2-12
	2.3.1 Coplanar Departure	2-12
	2.3.2 Non-Coplanar Departure	2-14
	2.4 Nuclear Propulsion Effects	2-14
	2.4.1 Nuclear Powered Vehicle Trajectories	2-14
	2.4.2 Nuclear Radiation Effects	2-17
	2.5 Escape/Rescue Requirements and Concepts for Lunar Orbit Arrival/Departure	2-17
	2.5.1 Escape/Rescue Requirements for Lunar Orbit Arrival/Departure	2-17
	2.5.1.1 Impact Trajectories	2-20
	2.5.1.2 Non-Impact Trajectory	2-20
	2.5.2 Escape/Rescue Concepts for Lunar Orbit Arrival/Departure	2-20
	2.5.2.1 Initial Manning Flight	2-20
	2.5.2.2 Routine Crew Rotation Flights	2-21
	2.5.2.3 Nuclear Propulsion Effects	2-21

Section	Page
2.5.3 Earth Based Rescue	2-21
2.5.3.1 Rescue Vehicle Based in Earth Orbit	2-21
2.5.3.2 Rescue Vehicle Based on the Surface of Earth	2-23
2.5.3.3 Lunar Orbit Alignment	2-23
2.5.3.4 Earth Based Rescue Requirements	2-26
2.6 Escape/Rescue Guidelines for Lunar Arrival/Departure	2-26
2.6.1 Escape/Rescue Guidelines for Initial Manning Flight	2-28
2.6.2 Escape/Rescue Guidelines for Routine Crew Rotation Flights	2-28
 3 LUNAR ORBITAL OPERATIONS	 3-1
3.1 Situation Description	3-1
3.2 Orbital Station Operations	3-2
3.2.1 Initial Manning and Activation	3-2
3.2.1.1 Major Subsystem Failure - Station Inoperative	3-3
3.2.1.2 Life Support/Environmental Control Subsystem Failure	3-4
3.2.1.3 Critical Failures	3-4
3.2.1.4 Critical Failure - Tug Inoperative	3-7
3.2.1.5 Radiation Environment Effects	3-8
3.2.1.6 Tumbling Orbiting Lunar Station	3-9
3.2.2 Routine Operations	3-9
3.2.2.1 Orbiting Lunar Station as Primary Rescue Operations Base	3-10
3.2.2.2 Escape to Lunar Surface Base	3-10
3.2.2.3 Orbiting Lunar Station Rescue from Lunar Surface	3-11
3.2.3 EVA Activities	3-15
3.2.3.1 Extra Vehicular Crewman Attached to an Orbiting Station	3-15
3.2.3.2 Crewman Separated from Station	3-18
3.2.3.3 Pressure Suit Tear	3-21
3.2.4 Deactivation	3-22
3.2.4.1 Subsystem Failure on Orbiting Lunar Station	3-22
3.2.4.2 Critical Failure of Orbiting Lunar Station	3-23
3.2.5 Escape/Rescue Guidelines	3-23
3.3 Lunar Tug Operations	3-27
3.3.1 Near Vicinity of Station	3-27
3.3.1.1 Orbital Tug Unable to Complete a Rendezvous and Docking Operation	3-27

Section		Page
	3.3.1.2 Loss of Tug Electrical Power	3-28
	3.3.1.3 Critical Failure of an Orbital Tug	3-30
	3.3.1.4 Logistics Cargo Transfer to and from the Orbiting Lunar Station	3-32
	3.3.1.5 Orbiting Lunar Station Maintenance and Repair	3-33
	3.3.1.6 Tug/Station Collision	3-33
	3.3.1.7 Tug Critical Subsystem Failure	3-34
3.3.2	Orbital Operations	3-36
	3.3.2.1 Scientific Satellite Placement	3-36
	3.3.2.2 Lunar Lander Tug Surface Sortie Flights	3-40
	3.3.2.3 Lunar Surface Base Logistics Flights	3-41
3.3.3	Escape/Rescue Guidelines	3-43
3.4	ORBITAL PROPELLANT DEPOT OPERATIONS	3-47
	3.4.1 Vehicle Servicing at the Propellant Depot	3-48
	3.4.2 Replenishment of Propellant Depot Supplies	3-52
	3.4.3 Escape/Rescue Guidelines for Propellant Operations	3-52
4	LUNAR SURFACE OPERATIONS	4-1
	4.1 Permanent Lunar Surface Base Operations	4-1
	4.1.1 Base Configurations	4-1
	4.1.2 Situations	4-4
	4.2 Lander Tug Local Operations	4-8
	4.2.1 Operational Phases	4-8
	4.3 Lunar Surface Traverse Operations	4-9
	4.3.1 Traverse Situations	4-9
	4.4 Lunar Surface Escape/Rescue Analysis	4-12
5	LUNAR SURFACE BASE ESCAPE/RESCUE ANALYSIS	5-1
	5.1 Lunar Surface Base Escape/Rescue Situations	5-1
	5.2 Lunar Surface Base Escape/Rescue Concept Definition	5-7
	5.3 Lunar Surface Base Escape/Rescue Operations Analysis	5-12
	5.3.1 Operations from Rescue Alert to Ready for Rescue Tug Separation	5-12
	5.3.1.1 Rescue Alert Signal	5-12
	5.3.1.2 Rescue Decision Making	5-16
	5.3.1.3 Orbital Operations	5-17

Section	Page
5.3.2 Operations from Rescue Tug Separation to Touchdown	5-17
5.3.2.1 Time Phasing of the Orbit	5-18
5.3.2.2 Descent and Landing	5-18
5.3.2.3 Crew Preparation (Denitrogenization)	5-25
5.3.2.4 Rescue Tug Descent Procedure	5-27
5.3.3 Escape/Rescue Operations on the Lunar Surface	5-28
5.3.3.1 Landing Distance for a Rescue Tug	5-28
5.3.3.2 Denitrogenization of a Distressed Crew	5-30
5.3.3.3 Rescue Equipment Capacities	5-32
5.3.3.4 Egress from Tug Rescue Vehicle	5-32
5.3.3.5 Unload Mobility Vehicle	5-32
5.3.3.6 Traverse to Disabled Base	5-33
5.3.3.7 Ingress to Disabled Base	5-34
5.3.3.8 Egress from Disabled Base	5-36
5.3.3.9 Traverse to Tug	5-41
5.3.3.10 Load Escape/Rescue Tug	5-42
5.3.3.11 Crew Base-to-Tug Transfer Time	5-44
5.3.4 Escape/Rescue Tug Operations to Return to Orbit	5-45
5.3.4.1 Time Phasing for Escape/Rescue Tug Ascent	5-48
5.3.4.2 Escape/Rescue Tug Ascent to Orbit	5-50
5.3.4.3 Rendezvous of Tug/Orbiting Lunar Station	5-52
5.3.4.4 Transfer of Rescued Crew from Tug to Orbiting Station	5-52
5.4 Lunar Surface Base Escape/Rescue Concept Tradeoffs	5-53
5.4.1 Escape from Lunar Surface Base	5-53
5.4.1.1 Escape in the EVA Mode to Standby Tug	5-53
5.4.1.2 Escape Via Pressurized Cabin Rover to a Standby Tug	5-54
5.4.1.3 EVA Escape in LESS (Lunar Escape System)	5-55
5.4.2 Rescue from Lunar Orbit	5-56
5.4.2.1 Rescue Response Times	5-56
5.4.2.2 Rescue Crew Pressure Suit Time Requirements	5-58
5.4.2.3 Rescue ΔV Requirements	5-58
5.4.3 Lunar Surface Base Escape/Rescue Concept Conclusions	5-59
5.5 Lunar Surface Base Escape/Rescue Guidelines	5-60

Section		Page
6	LANDER TUG LOCATION OPERATION	6-1
	6.1 Escape/Rescue Situations	6-1
	6.2 Escape/Rescue Concepts	6-3
	6.2.1 Escape	6-4
	6.2.2 Rescue	6-4
	6.3 Escape/Rescue Guidelines for Lander Tug Local Surface Operations	6-7
7	LUNAR SURFACE TRAVERSE OPERATIONS	7-1
	7.1 Traverse Escape/Rescue Situations	7-1
	7.1.1 EVA Traverse Escape/Rescue Situations	7-2
	7.1.1.1 Walking Traverses	7-2
	7.1.1.2 EVA Rover Vehicle Traverses	7-2
	7.1.1.3 Lunar Flyer Traverses	7-5
	7.1.1.4 Ground Effects Machine Traverse	7-9
	7.1.1.5 EVA Traverse Rescue Requirements	7-9
	7.1.2 Pressurized Cabin Rover Vehicle Traverses	7-9
	7.2 Traverse Escape/Rescue Concepts and Analysis	7-17
	7.2.1 Walkback Escape/Rescue Concept	7-17
	7.2.2 Escape/Rescue Rover Vehicle from Base	7-17
	7.2.3 Rescue Flyer from Base	7-23
	7.2.3.1 Response Time for Rescue Flyer	7-23
	7.2.3.2 Range for Rescue Flyer	7-23
	7.2.3.3 Payload Capacity of Rescue Flyer	7-25
	7.2.3.4 Search Capabilities from a Rescue Flyer	7-25
	7.2.3.5 Landing Distance for a Rescue Flyer	7-28
	7.2.3.6 Conclusions Regarding Rescue Flyer	7-29
	7.2.4 Lunar Lander Tug for Rescue from Surface	7-29
	7.2.5 Lunar Lander Tug for Rescue from Orbit	7-32
	7.2.6 Portable Emergency Escape Systems	7-33
	7.2.6.1 Surface-to-Surface Concepts	7-34
	7.2.6.2 Surface-to-Orbit Concepts	7-36
	7.2.6.3 Comparison of Escape Techniques	7-38
	7.2.7 Survival Package Drop for Rescue Support	7-39
	7.2.8 Buddy Vehicles for Escape/Rescue	7-41
	7.2.9 Comparison of Lunar Surface Traverse Escape/Rescue Concepts	7-43
	7.3 Escape/Rescue Guidelines for Lunar Surface Traverse Operations	7-47
8	EFFECT OF NO ORBITING LUNAR STATION ON ESCAPE/RESCUE PLAN	8-1
9	EFFECT OF NO LUNAR SURFACE BASE ON ESCAPE/RESCUE PLAN	9-1
10	EFFECT OF NO FOREIGN LUNAR ORBIT/SURFACE OPERATIONS ON ESCAPE/RESCUE PLAN	10-1
11	DESCRIPTION OF PORTABLE AIRLOCK AND EMERGENCY PRESSURE SUIT	11-1

Section	Page
Appendix A Lunar Escape/Rescue Orbital Velocity Needs	A-1
Appendix B Lunar Emergency Communication	B-1
Appendix C Tumbling Vehicle Escape/Rescue Analysis	C-1

Glossary

SYMBOLS, ABBREVIATIONS, AND DEFINITIONS

AMU	Astronaut Maneuvering Unit (generic term)
Activation Time	The time required to ready the rescue vehicle and crew for a rescue operation following receipt of the alert signal
Backpack	Portable Life Support System (PLSS) carried on the back of an astronaut (generic term)
Base	Lunar Surface Base (generic term)
Buddy System	Two or more men working together in the same location and environment
CC	Crew Compartment used to house and transport men on the PTV and tug (generic term)
Communications Lag	The time required for the distressed crew to communicate a request to the rescue crew
C-PTV	Chemically Powered Prime Transport Vehicle (generic term)
Delta V or Delta Velocity	Change in vehicle velocity in inertial space
Earth Vicinity	A general, unspecified location in Earth orbit or on Surface
EC/LSS	Environmental Control/Life Support System (generic term)
ECS	Environmental Control System (generic term)
EMV	Extravehicular Maneuvering Unit (generic term)
Escape	Utilization of on-hand equipment and resources, without outside assistance, to effect immediate removal from the proximity of danger
ESS	Emplaced Scientific Station (generic term)
FD	Propellant Depot (generic term)
Flyer	Generic term for any flying vehicle designed for limited travel over the lunar surface (LFV)
G&N	Guidance and Navigation
Hazard	Presence of a potential risk situation caused by an unsafe condition, environment, or act

IPP	Integrated Program Plan
IVA	IntraVehicular Activity
LCG	Liquid Cooled Garment
Lander	See Lunar Lander Tug (LLT)
LEAP	Lunar Escape Ambulance Pack
LESS	Lunar Emergency Escape System
LFV	Lunar Flying Vehicle (Flyer)
L ₂ Libration Point	Point of stable equilibrium in orbit on the far side of the Moon
LLT	Lunar Lander Tug (generic term); space tug with landing gear
LM	Lunar Module
LMP	Lunar Module Pilot
LOD	Lunar Orbit Departure
LOI	Lunar Orbit Insertion
LRV	Lunar Roving Vehicle (Rover)
LSB	Lunar Surface Base
LSSM	Lunar Scientific Survey Module
Maneuvering Work Platform	Platform designed for use in working on the exterior of an Orbiting Lunar Station
Mev	Million Electron Volts
MOLAB	Mobile Laboratory
MPL	Manned Payload
N-PTV	Nuclear-Powered Prime Transport Vehicle (generic term)
OLS	Orbiting Lunar Station (generic term)
OPS	Oxygen Purge System (generic term)
PDD	Project Description Document (produced by NASA-MSD)
PDI	Powered Descent Initiation
PGA	Pressure Garment Assembly

PLSS	Portable Life Support System or Backpack (generic term)
PTV	Prime Transport Vehicle used to transport personnel and cargo between Earth orbit and lunar orbit (generic term)
RCS	Reaction Control System
Rescue	Utilization of outside assistance to effect a return to a safe haven
rem	Roentgens equivalent man
Response Time	The span of time between the occurrence of an emergency and the placement of the stranded crew into a temporary or permanent safe haven
RNS	Reusable Nuclear Shuttle (N-PTV) (generic term)
Rover	Generic term for any lunar surface transport vehicle moving on tracks, wheels, etc. (LRV)
Safety	Freedom from chance of injury/loss
SLSS	Secondary Life Support System (generic term)
Survival	Refers to the utilization of resources immediately at hand to extend the lives of crewmen to permit escape or rescue
Survival Time	Refers to the maximum length of time that a crew can live following an emergency, using resources immediately at hand
Space Tug	Multipurpose vehicle used to transport men and cargo in lunar orbit and to the lunar surface (generic term)
Tug	Space Tug
TEI	Transearth Injection
Tumbling	Random angular motion about any axis
ΔV	Delta velocity
Pogo	A minimal weight, cabinless, rocket propelled vehicle for horizontal flights in which the crew manually stabilizes and flies the vehicle from a standing position.

Section 1

INTRODUCTION

This report presents the results of the technical analysis of escape/rescue/survival situations, crew survival techniques, alternate escape/rescue approaches and vehicles, and the advantages and disadvantages of each for advanced lunar exploration. Candidate escape/rescue guidelines are proposed and elements of a rescue plan developed.

The recommended escape/rescue guidelines and the detailed rescue plan are extracted from the analysis results contained in this volume and are presented in MSC-03976, Technical Summary.

1.1 Scope and Objectives

This escape/rescue study analysis task has been directed at all hardware and operational situations associated with advanced lunar missions under consideration. The spectrum of situations starts with the first advanced manned flight to the lunar area and includes the final deactivation of both surface and orbital program equipment elements.

The overall study task objective is to identify escape/rescue safety guidelines, to develop realistic hardware and operational concepts, and to prepare an escape/rescue plan applicable to future manned lunar programs.

1.2 Approach

The escape/rescue analysis addressed the use of various hardware elements such as the orbital lunar station, prime transport vehicle, and lunar surface base, involved in the advanced lunar program, and the activities of the crewmen operating this equipment. For analysis purposes, the task was separated into three parts based on hardware element deployment: lunar arrival/departure; lunar orbit; and lunar surface.

Escape/rescue situations were developed based on both planned operations with the various types of possible hardware elements and on inputs from the hazards

analysis task. A requirements envelope was then established, expressed in terms of operational and performance limits and constraints. Critical requirements categories are: communications capability, crew survival time following an emergency, rescue or escape response time, and delta velocity (ΔV) needs. Candidate concepts - including some possible design solutions - were then defined, based on operations analyses and tradeoff evaluations. Recommended concepts and guidelines were then re-evaluated from the standpoint of safety considerations.

1.3 Ground Rules

In accordance with directions from the Statement of Work, the study complied with the following ground rules:

- a. Lunar surface activities commenced with the final flight phase immediately preceding spacecraft touchdown on the lunar surface.
- b. The lunar surface activities concluded when the crew had returned to a lunar ascent vehicle and ascent had begun.
- c. Lunar orbital activities commenced at lunar orbit insertion and concluded either with spacecraft contact with the lunar surface or upon completion of the transearth maneuver.
- d. It was assumed that the design and routine internal operation of major lunar orbital elements such as the tug, nuclear shuttle, or orbital station were optimized; however, failure of these elements to accomplish their intended mission was examined.
- e. No significant effort was devoted to hardware design.
- f. It was a study goal that results were to be general enough that the escape/rescue guidelines and plan would be valid regardless of lunar program hardware and operational plan changes.

1.4 Assumptions

The following assumptions were used to establish a baseline from which typical operational sequences and escape/rescue situations were developed.

- a. Basic hardware elements that will be used in the Lunar program will be generally similar in design and function to those described in the Integrated Program Plan and the Program Description Documents.
- b. Apollo Program techniques and experience can be used as a general guide, particularly in the area of human factors and operational time lines.

Section 2
LUNAR ARRIVAL/DEPARTURE OPERATIONS

2.1 SITUATION DESCRIPTION

The basic relations of velocity and time for lunar arrival and departure of the Prime Transport Vehicle (PTV) are described in order to determine the escape/rescue requirements. Consideration is given to both the initial manning flights and subsequent crew rotation and logistics flights.

Rescue operations for the initial manning flights will not have the benefit of personnel in the lunar vicinity. Consequently, rescue operations must be Earth based, either orbit or surface, with a resultant response time in days. The alternative to rescue is to provide self-contained escape capability for either autonomous Earth return or escape to a temporary safe haven to await Earth based assistance. The routine crew rotation flights will usually be made with the use of a crew compartment in contrast to the initial manning flights which will probably include fueled tugs. The absence of autonomous vehicles such as the tug makes escape impossible without augmenting the crew compartment.

In the following sections, the velocity requirements for Lunar Orbit Insertion (LOI) are given. The family of possible trajectories at lunar arrival/departure in terms of velocity vectors is described and subdivided into two classes; those that will result in an impact with the lunar surface, and the so-called safe trajectories, i.e., those that will not result in impact with the lunar surface. The effects of failure of the propulsion or guidance system during lunar arrival operations are examined, and the resulting escape/rescue situations are defined. Similarly, lunar departure operations are analyzed. An examination of the effects on escape/rescue of using nuclear propulsion in the prime transport vehicle is also included. Escape/rescue concepts and requirements are presented for both initial manning and routine logistics flights, including an analysis of Earth-based rescue concepts. The resulting escape/rescue guidelines for arrival/departure operations are then listed.

2.1.1 Lunar Orbit Insertion (LOI)

All practical circumlunar trajectories approach the periselene at velocities exceeding the lunar escape velocity. Therefore, a velocity impulse is required to insert a vehicle into lunar orbit and prevent it from escaping

the lunar sphere of influence. The required velocity impulse to establish a circular orbit coplanar with the approach asymptote is a function of the translunar flight time and the inclination of the trajectory plane to the moon's orbital plane. Figure 2-1 shows the spread of velocity impulses required to establish a coplanar, 60 n.m. lunar orbit as a function of flight time and trajectory inclination (i_R). Application of these velocity impulses results in a circumlunar velocity of 5340 ft/sec. The maximum velocity to establish a lunar elliptical orbit and thus avoid escaping the lunar sphere of influence is 7550 ft/sec. Velocity impulses of approximately 2210 ft/sec less than those shown on Figure 2-1 will provide lunar capture in a high elliptical orbit. For example, nominal translunar trajectory is 96 hour flight time at an angle of 75 degrees corresponding to an Earth orbit of 260 n.m. at 55° inclination which requires a ΔV of 2930 ft/sec to establish a 60 n.m. coplanar orbit. In an emergency, a ΔV of 720 ft/sec would provide a highly elliptic lunar orbit from which a crew could be rescued later.

2.1.2 Trajectory Velocity Vectors

Assuming the PTV has arrived at the 60 n.m. altitude for Lunar Orbit Insertion into a coplanar orbit, two classes of trajectories can be generated from this point, elliptic or hyperbolic depending on the magnitude and direction of the velocity vector. Figure 2-2 shows the velocity vector dividing line between elliptic and hyperbolic trajectories for a point 60 n.m. above the lunar surface. The velocity vector for a 60 n.m. circular orbit (5340 ft/sec) is shown along with the velocity vector for arrival and departure from or to a 96-hour flight time trajectory (8270 ft/sec).

Velocity vectors whose flight path angles are above the horizontal are for trajectories that have passed perilune and are headed for apolune in the case of ellipses, and outside the lunar sphere of influence for hyperbolas. Velocity vectors with flight path angle downward are headed directly toward perilune which may be less than the radius of the lunar surface.

Figure 2-3 presents an envelope of velocity vectors whose trajectories have perilunes at 50,000 feet above the lunar surface. This envelope is superimposed on the Figure 2-2 velocity vectors for both ellipses and hyperbolas (dotted lines). Trajectories with perilunes above 50,000 feet are those whose velocity vectors terminate to the right of the cone shaped envelope. However, a hyperbolic trajectory whose velocity vector is above the horizontal has passed perilune and consequently will not impact. Elliptic trajectories above the horizontal and to the left of the envelope will

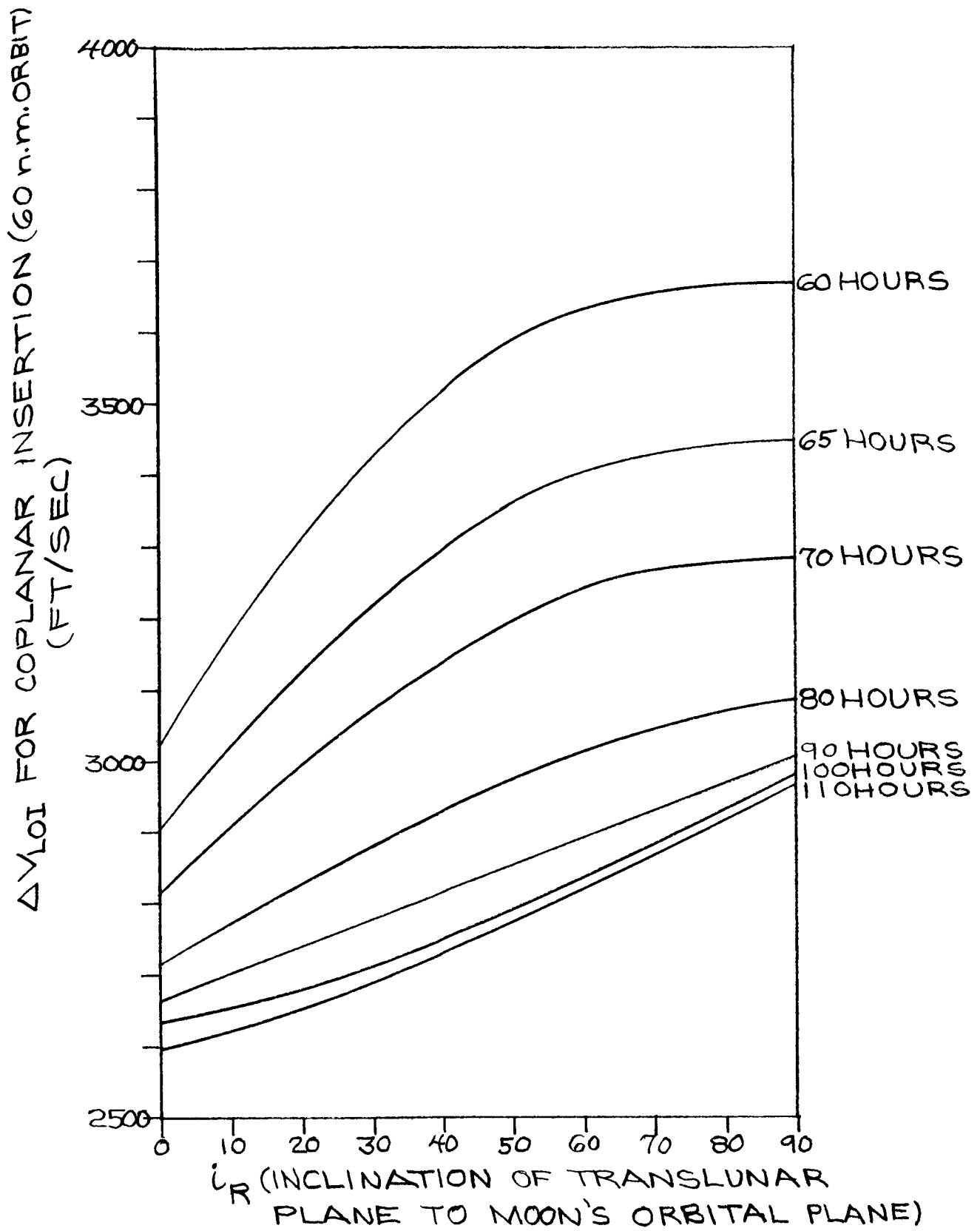

Fig. 2-1 Lunar Orbit Insertion ΔV - Coplanar

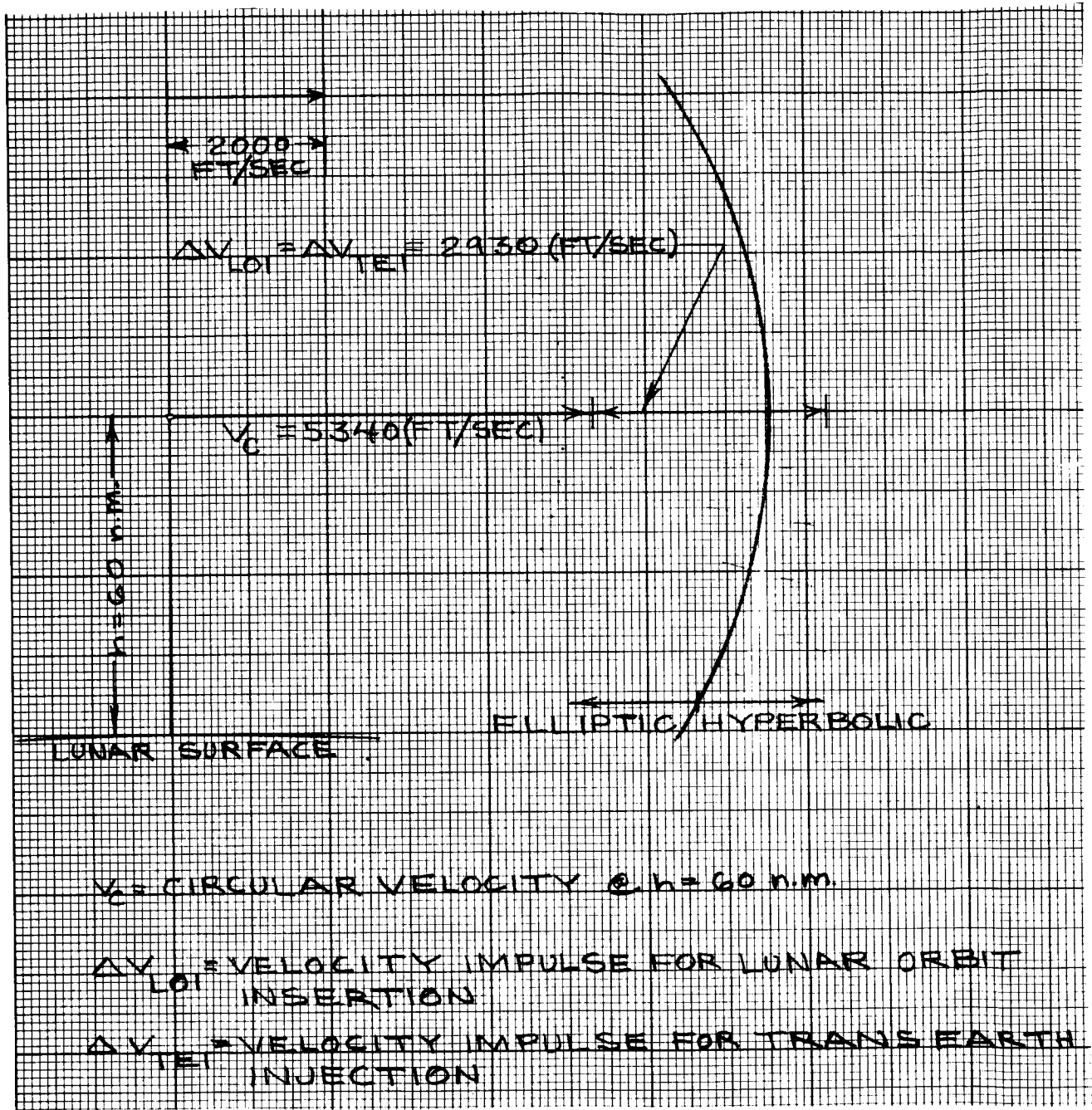

Fig. 2-2 Lunar Trajectory Velocity Vectors

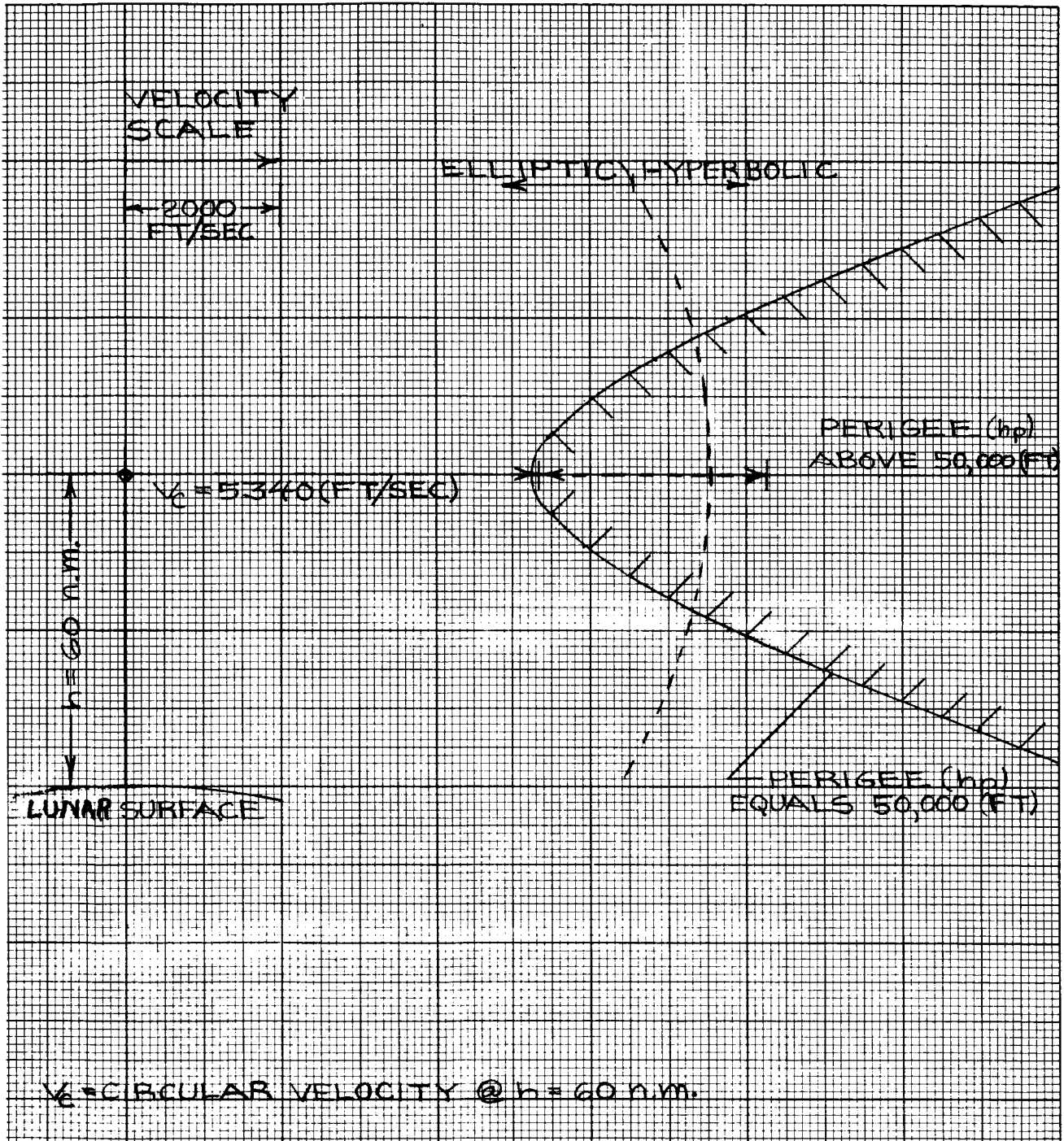

Fig. 2-3 Envelope of Velocities for Trajectories With Perigees Above 50,000 Feet

pass through apolune before returning to an impact perilune, thus allowing longer reaction time than for those below the horizontal. The envelope of velocity vectors in Figure 2-3 are modified in Figure 2-4 to show the line between impact and non-impact trajectories. It should be noted that the difference between the velocity for a 60 n.m. circular orbit and the velocity of an elliptic orbit with a 50,000 foot perilune is quite small (approximately 70 ft/sec). The impact/non-impact envelope is applied to lunar arrival and departure operations in the following sections.

2.2 LUNAR ARRIVAL OPERATIONS

As shown in Section 2.1, failure to achieve proper lunar insertion can result in either a hyperbolic trajectory or an elliptic orbit, either of which may be on a course that will impact the lunar surface. The crew can be provided the means to control propulsion and guidance to avoid extreme conditions, but the following analysis is presented in the interest of completeness.

Malfunction of either the propulsion system or the guidance system for maintaining thrust vector control could be responsible for failure to achieve the planned orbit. The solid circle on Figure 2-5 shows the locus of possible final velocity vector end points that could result from either type of malfunction if corrective action is not taken. The example shown is for a case where the propulsion system imparted the proper ΔV , but the thrust vector was misaligned and resulted in a greater than desired velocity magnitude and a flight path angle downward; an elliptic orbit whose perilune is below 50,000 feet.

The inner dotted circle is the locus of the resultant velocity vector end-points of an initial retro velocity impulse whose magnitude (approximately 1940 ft/sec in this case) is limited to a value that cannot produce an impact trajectory. Thus, if the lunar orbit insertion maneuver was accomplished by using a series of such impulses, the magnitude of each being limited in a fail-safe manner (say by using solid propellants), the possibility of an impact trajectory could be eliminated.

2.2.1 Propulsion Malfunction

A propulsion system failure not complicated by guidance malfunction can result in either underburn or overburn including zero burn. The resultant velocity vector lies along the horizontal in Figure 2-5, and either terminates to the right of the near-vertical curved line (hyperbolic trajectory) or

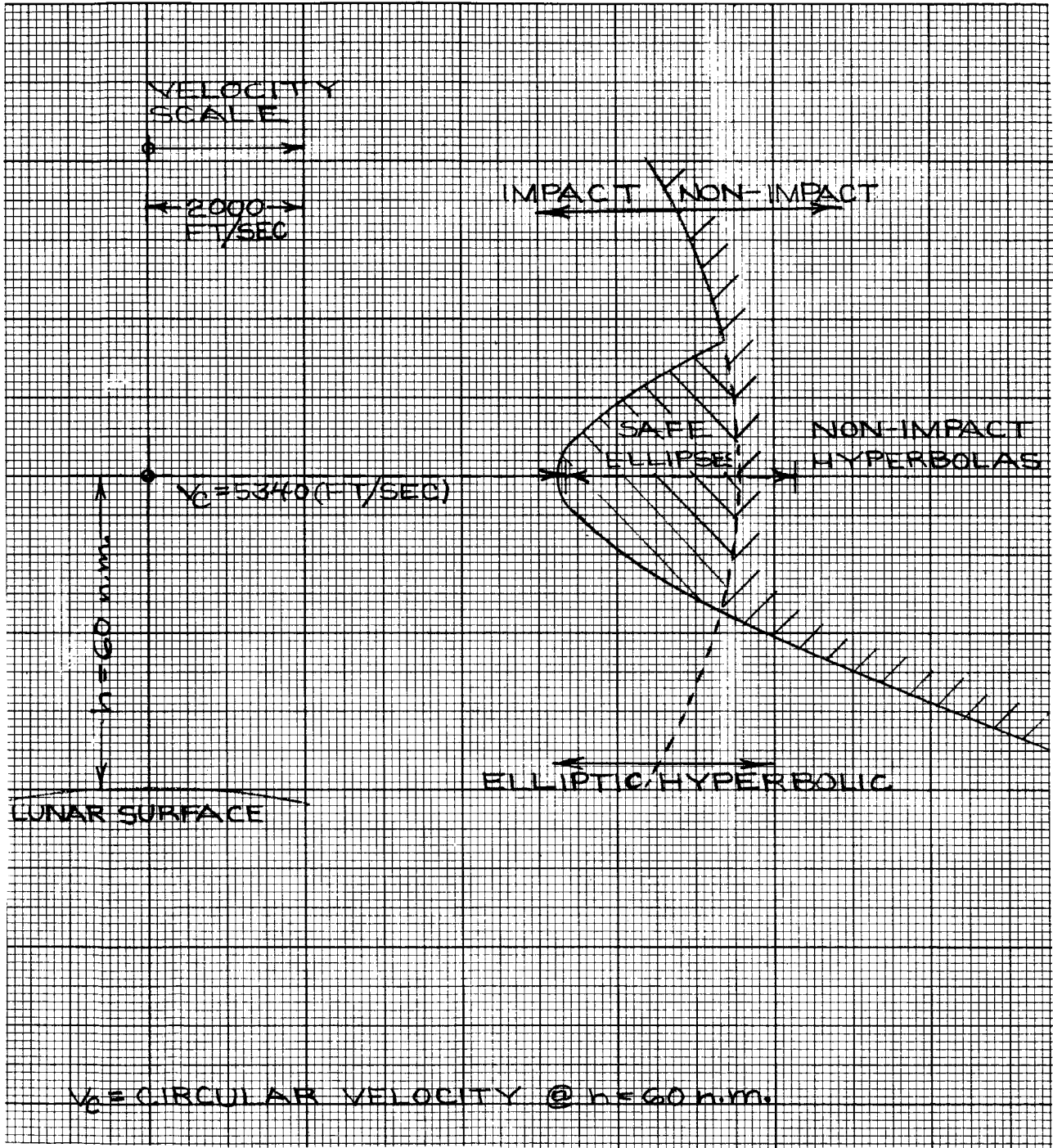

Fig. 2-4 Envelope of Velocities for Non-Impact Trajectories

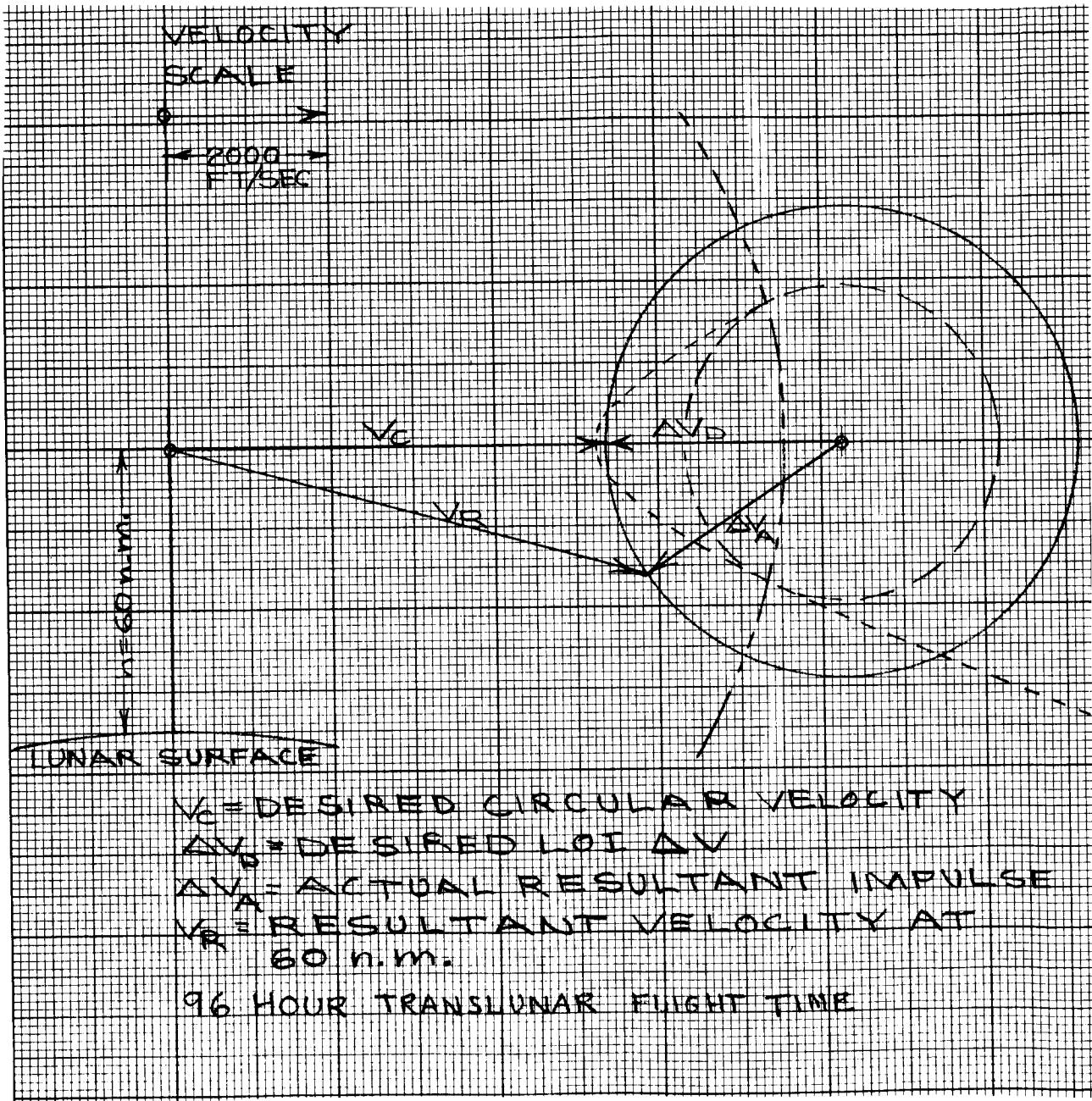

Fig. 2-5 Lunar Orbit Insertion Failure Envelope

to the left of it (elliptic trajectory). Note that an impacting hyperbolic trajectory is not possible for a pure propulsion failure because the resultant velocity vector is coincident with the desired circular velocity vector.

2.2.1.1 Hyperbolic Trajectory

A zero or partial burn, not complicated by guidance malfunction, which results in a velocity of more than 7550 ft/sec at periselene places the prime transport vehicle (PTV) on a hyperbolic escape trajectory out of the lunar sphere of influence. The approach velocity for a nominal 96-hour translunar flight exceeds the parabolic escape velocity of 7550 ft/sec for a 60 n.m. periselene by approximately 720 ft/sec. Complete propulsion failure at insertion would result in the vehicle continuing back out of the lunar sphere of influence on a mirror image of its hyperbolic approach trajectory. For the initial manned flights, no assistance in the form of rescue from the lunar vicinity is available. Consequently, an escape situation exists unless the PTV is on a free Earth return trajectory which passes the problem off to Earth. Assuming complete failure of the propulsion system, another means of propulsion must be used to effect an escape. This can be either in the form of an attached, fueled, tug or a crew compartment with its own propulsion and guidance system. The propulsion requirement to return to lunar orbit, in terms of velocity impulse, is a direct function of the time from periselene until initiation of the retro maneuver. If procedures are set up to respond immediately in the event of propulsion failure during lunar orbit insertion, the crew can detach the crew compartment from the prime transport vehicle (PTV) and with an expenditure of approximately 1000 ft/sec attain a lunar elliptical orbit. For times from periselene in the order of hours, Table 2-1 presents the velocity impulse and time requirements to place the crew back in lunar orbit where they could await rescue.

Table 2-1
HYPERBOLIC ESCAPE VELOCITY REQUIREMENTS

TIME FROM PERISELENE (HOURS)	TOTAL ΔV (FT SEC) REQUIRED TO RETURN TO 60 N.M. LUNAR ORBIT IN:		
	6 HOURS	12 HOURS	18 HOURS
4	7,200	5,400	4,800
6	9,000	6,200	5,300
8	10,700	7,000	5,800
10	12,300	7,800	6,300
12	14,100	8,500	6,800

NOTE: 108 Hour Translunar Flight Time

2.2.1.2 Elliptical Orbit

For partial burn resulting in a velocity of less than 7550 ft/sec at 60 n.m., the prime transport vehicle would be placed on an elliptic orbit. As the crew for the initial manning flight would have supplies for a long period of time, no immediate danger would exist and they could await Earth rescue similarly to the previous case of returning to lunar orbit. For the case of overburn in the propulsion system, an excess velocity change of 70 ft/sec results in a perilune of 50,000 ft which is reached in approximately one hour from periselene. Any overburn that exceeds the desired by more than 70 ft/sec will result in an impact trajectory which is considered in the next section. For the case of a small overburn, corrective action can be taken using secondary systems such as the ACS to establish the 60 n.m. circular orbit.

2.2.1.3 Elliptical Orbit Impact Trajectory - Propulsion Overburn

Lunar impact trajectory can result from a failure of the propulsion system to cut off, thereby imparting more velocity impulse than required. For overburn the time before lunar impact, consequently the escape time, is a direct function of the amount of additional velocity change imparted to the PTV. For a small overburn, in the order of 70 to 100 ft/sec, a time of 40 to 50 minutes is available before impact. For large overburns, in the order of 1000 to 1300 ft/sec, the time to impact is in the order of 8 to 10 minutes. For the initial manned flight the crew must escape from the PTV for the case of excessive overburn. The only alternative is to be able to reorient the

thrust vector and apply a corrective thrust to take out the effects of the overburn. The time requirements imply that the means of escape (either fueled tug or powered crew compartment) must be manned and activated at time of lunar insertion.

2.2.2 Guidance System Failure

In the event that the propulsion system imparts the correct magnitude of velocity impulse, but the guidance system fails to maintain the proper thrust vector control, the resulting envelope of velocity vectors is shown by the solid circle on Figure 2-5. By decoupling the propulsion system and guidance system failures, the resultant velocity vectors must either lie along the original velocity vector for propulsion failures, or be contained in the set whose ends lie within or on the circle for guidance system failures. The possible trajectories that may result from a malfunction at lunar insertion at 60 n.m. altitude are defined by the dotted curve on Figure 2-5. The area to the right of the dotted curve are those velocities that result in a non-impacting trajectory. The definition of non-impacting is a trajectory whose perilune is 50,000 feet or more above the lunar surface. Those velocity vectors below the horizontal and cone-shaped curve are impact trajectories, including the hyperbolic escape trajectories which pass through perilune before escaping. As mentioned earlier, the dividing line between elliptical and hyperbolic orbits is the near vertical curved line. The velocities above the horizontal to the left of the dotted curve represent elliptical orbits which will pass through apolune first, but will impact because their perilunes are below 50,000 feet. However, the time to react is in the order of an hour compared to the impact trajectories below the horizontal which are headed directly towards an impact perilune with reaction times in the order of minutes.

2.2.2.1 Escape from Impact Trajectories

For those trajectories with an imminent impact (below the curve in Figure 2-5) rescue is not feasible within the few minutes reaction time available. The crew must take action to provide a corrective impulse to at least get back on an impact-free trajectory even though it may be hyperbolic. For the 96 hour case illustrated by the circle, the ΔV for a safe trajectory is in the order of a 1000 feet/sec while that to regain a safe ellipse from the right hand side of the circle is 4000 ft/sec. For those cases where a fueled tug is available, the tug could provide the escape ΔV providing it is manned

and activated. For normal crew rotation flight with only a crew compartment and no tug, a separate propulsion capability must be provided.

2.2.2.2 Escape/Rescue from Hyperbolic Trajectories

The velocity impulses required for rescue or escape from a hyperbolic trajectory are shown on Table 2-2. The left part of the Table gives the ΔV required to leave a 60 n.m. lunar orbit and rendezvous with the distressed vehicle, while the right hand part gives the ΔV to return to lunar orbit either in a rescue or escape mode. These values are based on 108 hour translunar flight time. Faster flight times will require slightly higher values. (See Appendix A)

TABLE 2-2
ESCAPE/RESCUE VELOCITY IMPULSE REQUIREMENTS
FROM HYPERBOLIC TRAJECTORIES (108 HOUR TRANSLUNAR FLIGHT TIME)

DISTRESSED VEHICLE TIME FROM PERISELENE (DELAY + CHASE) (HOURS)	RENDEZVOUS INCLUDING A DELAY TIME OF:			RETURN TO LUNAR ORBIT IN:		
	2 HRS	4 HRS	6 HRS	6 HRS	12 HRS	18 HRS
4	9,600	-----	-----	7,200	5,400	4,800
6	5,700	16,000	-----	9,000	6,200	5,300
8	4,600	8,600	20,000	10,700	7,000	5,800
10	4,000	6,400	11,500	12,300	7,800	6,300
12	3,600	5,400	8,300	14,100	8,500	6,800

(Delay time is the elapsed time from the distressed vehicle passing periselene until the rescue vehicle leaves the 60 n.m. lunar orbit)

2.3 LUNAR DEPARTURE OPERATIONS

2.3.1 Coplanar Departure

The resulting velocity vectors from a coplanar trans-Earth injection burn are shown by the solid circle on Figure 2-6 along with the envelope of impact trajectories. As mentioned previously in the lunar arrival section, for a straight propulsion failure the resultant vector will lie along the horizontal. For guidance system failure, but with a proper burn time, the end point of the resultant velocity vector will lie on or within the circle. The most severe case is contained within those that result in an immediate impact trajectory, i.e., below the horizontal and the dotted cone. Reaction

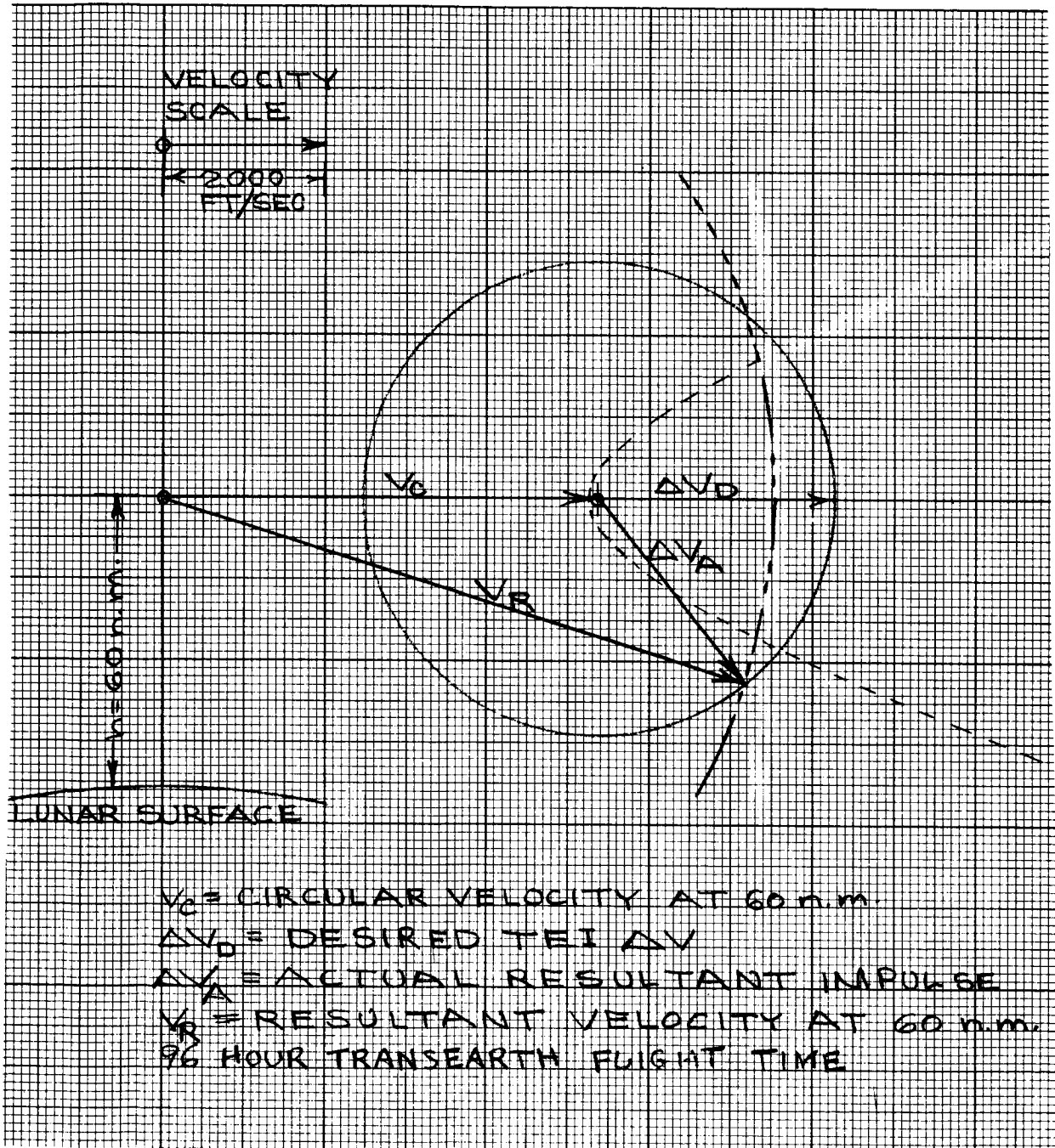

Fig. 2-6 Transearth Injection (TEI) Failure Envelope

time is in the order of minutes and any remedial action must be self-generated in the form of escape capsule, self-propelled crew compartment, or fueled tug. The magnitude of the correction velocity impulses required can be ascertained from Figure 2-6 and must be sufficient to get the crew on a non-impact trajectory. If a non-impact trajectory can be attained, then the crew can await rescue.

2.3.2 Non-Coplanar Departure

Normal lunar departure may require large plane changes in order to properly align with the Earth-Moon line due to the rotation of the moon about the Earth while the PTV is in lunar orbit (refer to Section 2.5). For small changes (less than 20 degrees) a single burn insertion may be satisfactory. However, for large plane changes, the 3-burn sequence involving an intermediate ellipse can be used. A typical sequence for a 90 degree plane change is shown on Figure 2-7. The velocity impulses are as follows:

Burn 1	(36 hour ellipse)	1960 ft/sec
Burn 2	(90 Degrees)	910 ft/sec
Burn 3	(72 hour TEI)	1596 ft/sec

Burn #1 involves the same hazards as for a coplanar injection only with smaller velocities. Burn #2 has the hazard that a failure could result in an impact trajectory, but magnitude of velocity required to correct is smaller than previous cases and the reaction time is long enough to allow rendezvous and rescue to be considered. Burn #3 is of smaller magnitude and will be made at a higher altitude with a resulting higher periselene. In general the three-burn departure has less stringent escape/rescue requirements than the single-burn transEarth injection.

2.4 NUCLEAR PROPULSION EFFECTS

The use of nuclear propulsion will affect two areas of Lunar Arrival/Departure Escape/Rescue consideration; the actual arrival and departure altitudes, and the radiation danger to an escape or rescue effort.

2.4.1 Nuclear Powered Vehicle Trajectories

A lunar orbit insertion sequence suggested in Appendix E of MSC-03977 for a nuclear powered Primary Transport Vehicle (PTV) is shown on Figure 2-8. This sequence uses the cooling pulses to provide the last increments of velocity impulse required for lunar insertion. The initial burn for lunar orbit insertion is initiated at an altitude of 100 n.m. or more. Several orbits of cooldown pulses are employed to attain the desired 60 n.m. orbit.

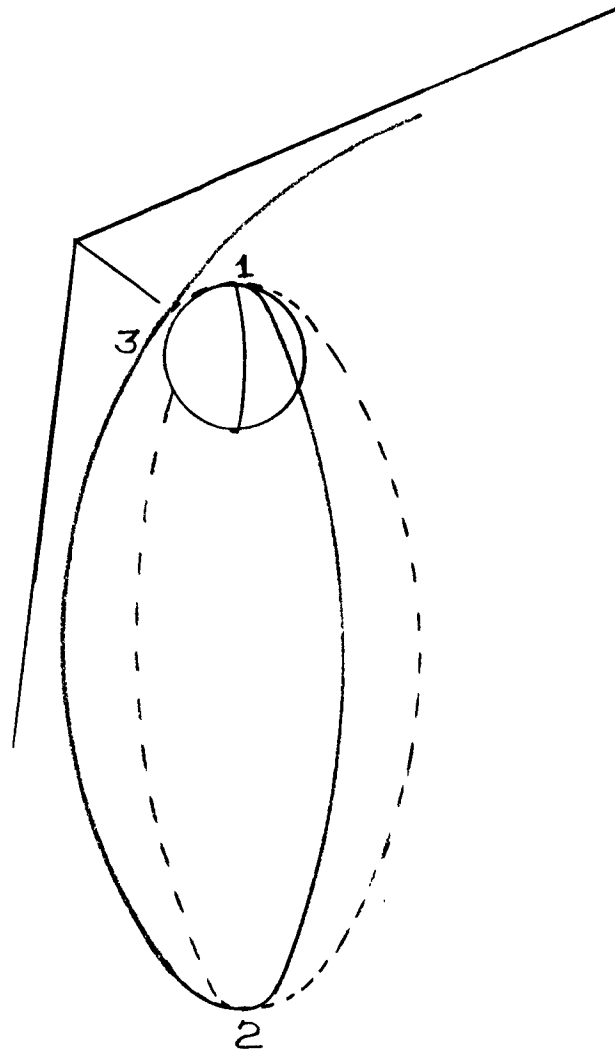
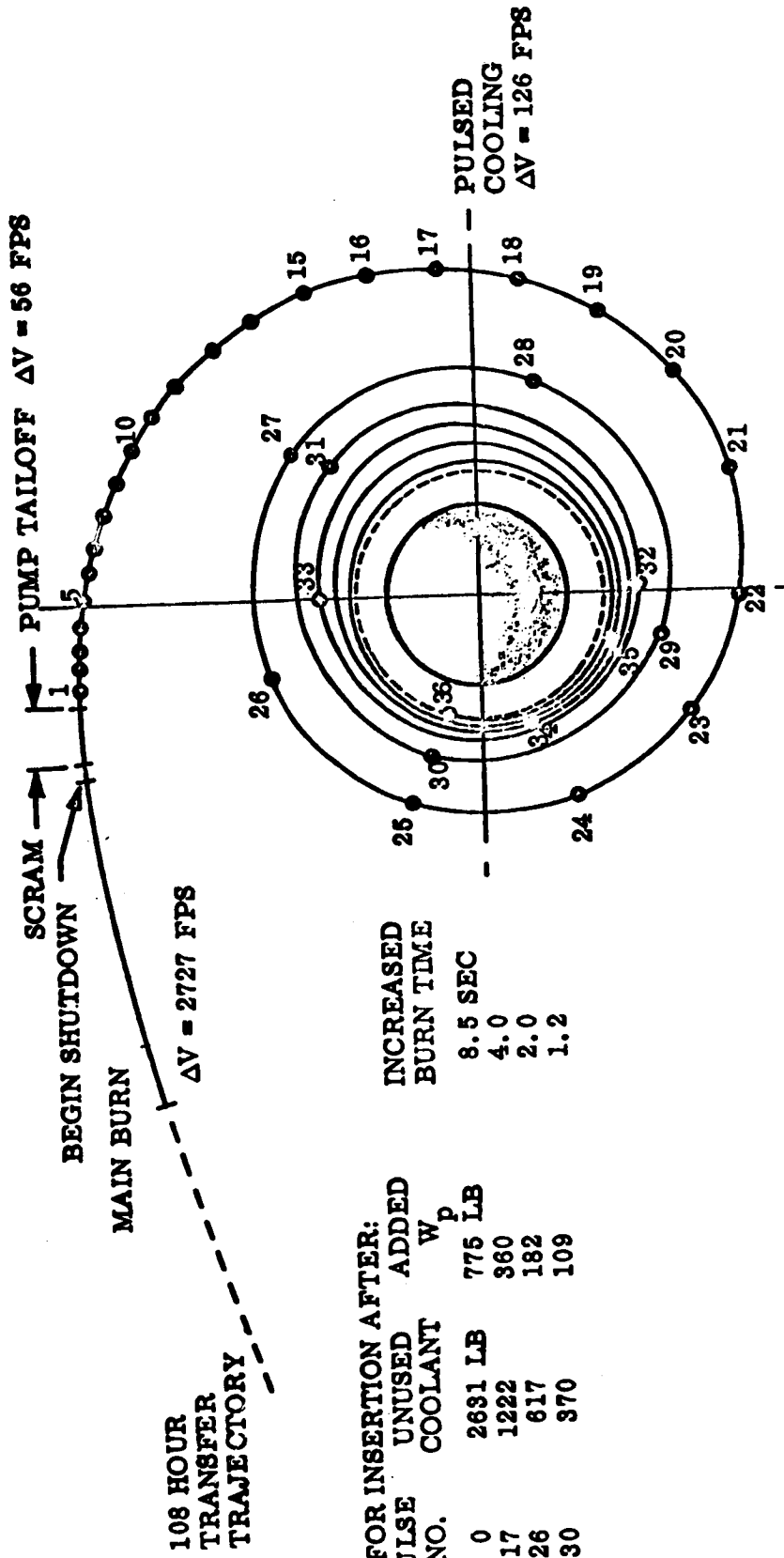

Fig. 2-7 Three-Burn Departure



FOR INSERTION AFTER:	
PULSE NO.	UNUSED COOLANT
0	2631 LB
17	1222
26	617
30	370

INCREASED BURN TIME	
W _P	REVS
775 LB	0.29
360	0.56
182	0.99
109	1.85

PULSE NO.	TIME AFTER SCRAM	REVS	TIME TO NEXT PULSE	% IMPULSE RECOVERED
17	36.3 MIN	0.29	4.5 MIN	54
22	1.1 HR	0.56	9.8	66
26	2.0	0.99	19.7	76
30	3.8	1.85	37.0	85
32	5.1	2.55	1.0 HR	90
33	6.2	3.06	1.4	93
34	7.5	3.73	1.8	95
35	9.3	4.62	2.4	98
36	11.7	5.85	-	100

Fig. 2-8 Lunar Orbit Insertion with Nuclear Propulsion, Using Cooldown Pulses

The insertion could be accomplished with a single burn if the cooldown pulses were nullified by venting them through a null thrust arrangement. The effect of raising the initial insertion altitude is to open the non-impact cone of velocities given previously in Figure 2-5. In other words the higher the altitude the steeper the flight path angle must be for impact for the same magnitude of velocity. The velocity requirements for escape and rescue are of the same magnitude as the 60 n.m. case, with the difference in circular velocity approximately 200 ft/sec.

The lunar departure of a nuclear vehicle is quite similar to chemical propulsion with the exception that the initial impulse is a little less and the additional velocity is imparted by cooling pulses after each main burn.

2.4.2 Nuclear Radiation Effects

The dose rates generated by the NERVA engine immediately after shutdown are shown in Figure 2-9. For escape or rescue these dose rates must be avoided. For escape from a vehicle on an immediate impact trajectory the reaction time is in the order of minutes. Figure 2-9 gives a dose rate of 2 Rem/sec 100 seconds after shutdown, decreasing to 1 Rem/sec 300 seconds after shutdown. Escape will have to be accomplished in this time frame with consequent radiation of 1 to 2 Rem/second. This radiation is for the engine viewed at 90 degrees. The crew compartment is located at the end opposite the engine and consequently is shielded by the PTV. The effect of this shielding is shown on Figure 2-10 which indicates an attenuation of 10^{-3} within an angle of 15 degrees of the center line.

For either escape or rescue, a separate means must be provided so that the attitude of the PTV can be oriented and held so that escape or rescue can be accomplished through this safe view angle.

2.5 ESCAPE/RESCUE REQUIREMENTS AND CONCEPTS FOR LUNAR ORBIT ARRIVAL/DEPARTURE

In the preceding sections no distinction has been made between the initial manning and activation flight and the subsequent routine crew rotation and logistics flights, because the resulting situations were not dependent on the flight program. In this section the escape/rescue requirements are summarized and the escape/rescue concepts for each set of flights are detailed.

2.5.1 Escape/Rescue Requirements for Lunar Orbit Arrival/Departure

Based on the analysis in the previous sections, the lunar orbit arrival/departure escape/rescue situations have been defined as follows:

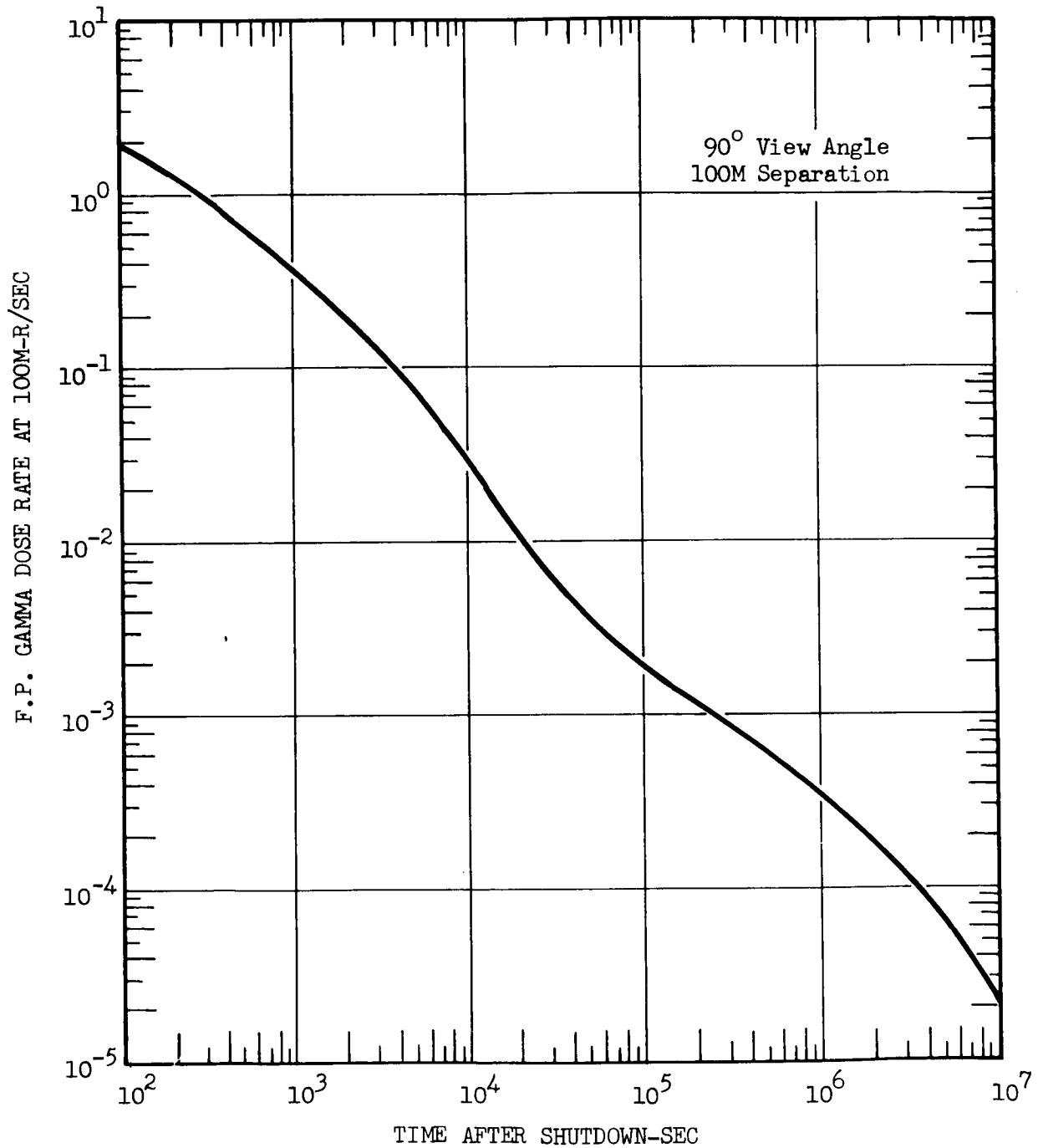

Fig. 2-9 Fission Product Gamma Dose Rate vs Time After Shutdown from the NERVA Core - LOI Burn

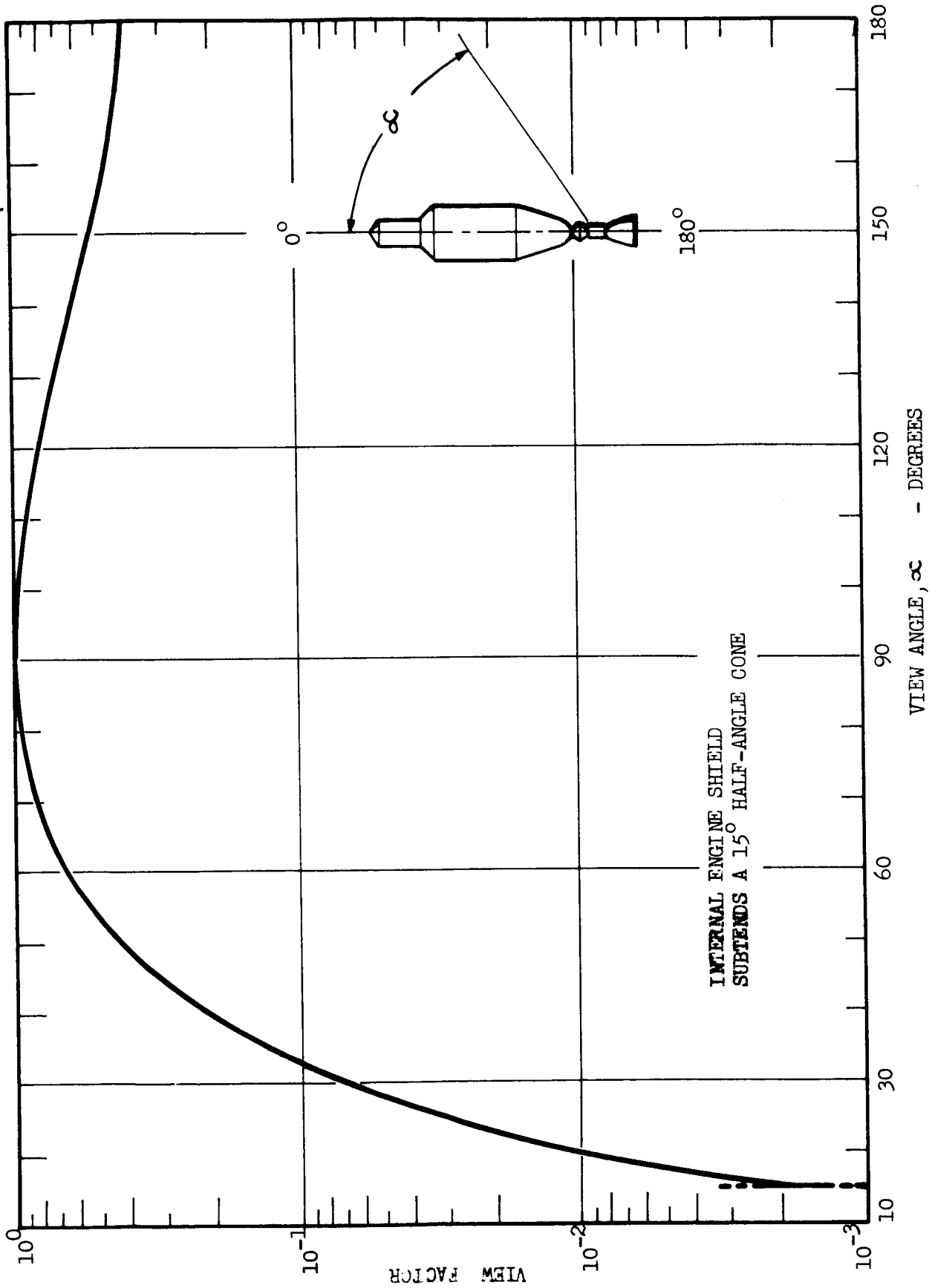

Fig. 2-10 Effect of View Angle on Fission Product Gamma Dose Rate

Impact Trajectory

Hyperbolic

Elliptic

Non-Impact Trajectory

Hyperbolic

Elliptic

2.5.1.1 Impact Trajectories

Impact trajectories are not considered realistic, since crew control of either propulsion or guidance will avoid such trajectories. Any impact trajectory that could reasonably be allowed to occur can be escaped from by a crew compartment with a ΔV capability of 1000 ft/sec used to reach a safe elliptical orbit.

2.5.1.2 Non-Impact Trajectory

The elliptical non-impact trajectory is the safest condition outside of the planned lunar orbit. The crew can be rescued, or if propulsion is available, they can place themselves in a circular lunar orbit for an additional 2000 ft/sec or less.

For the non-impact hyperbolic orbit, the time to initiate escape or rescue is still critical. The longer the delay the larger the velocity impulse required to return to lunar orbit as shown previously in Table 2-2. An on-board crew compartment or tug propulsion capability of 1000 ft/sec should be provided in order to avoid a hazardous chase for rescue.

2.5.2 Escape/Rescue Concepts for Lunar Orbit Arrival/Departure

2.5.2.1 Initial Manning Flight

The initial flight must include the capability for the crew to escape from the Prime Transport Vehicle (PTV) and to attain either a safe lunar orbit to await Earth rescue or to return to Earth orbit. For the lunar orbit option, sufficient consumables should be aboard for the crew to survive in lunar orbit for 14 days.

The lunar orbit option requires a total of 1000 ft/sec while the Earth orbit return will require an additional 10,000 ft/sec for Earth orbit insertion. A fully fueled and provisioned tug capable of abort and Earth return provides the most flexibility.

2.5.2.2 Routine Crew Rotation Flights

For rotation flights, the crew may be transported in a crew compartment attached to the Prime Transport Vehicle, but without the tug propulsion module. At lunar arrival, the crew could find itself on an impact trajectory with no time available to await rescue. The crew compartment should be augmented to provide an escape capability. This will include a propulsion system with a nominal ΔV capability of 1000 ft/sec to allow the crew to attain a safe trajectory. The propulsion system must also have quick reaction capability and long storage life. The guidance system should be separate from the main PTV and activated and updated before the lunar insertion burn. Normal emergency life support for 12 hours should be provided.

In order to minimize reaction time to rescue a crew that has achieved a safe elliptical orbit, the rescue tug in lunar orbit should be fully prepared for a rescue mission wherever a crew arrival or departure is scheduled.

2.5.2.3 Nuclear Propulsion Effects

The use of nuclear propulsion for the Prime Transport Vehicle (PTV) offers the advantage that the initial lunar orbit insertion burn will be made at a higher altitude, thereby decreasing the chance of an impact trajectory somewhat.

A major disadvantage for escape or rescue is the radiation environment. For either escape or rescue an independent attitude control system is necessary in order to maintain the PTV in a proper attitude so that the escaping crew can stay within the 30 degree radiation shadow cone of the PTV while escaping or being rescued. The system must be capable of maintaining attitude for a long enough duration for the crew to attain a safe distance of at least 150 n.m.

2.5.3 Earth Based Rescue

Two concepts can be considered for using vehicles based in the Earth vicinity to rescue personnel from lunar orbit; a rescue vehicle stationed in Earth orbit and a dedicated rescue vehicle on the surface of Earth.

2.5.3.1 Rescue Vehicle Based in Earth Orbit

The rescue vehicle based in Earth orbit would seem to offer the quickest reaction. However, the orbit must have the proper relation to the Earth-Moon line for translunar injection (see Fig. 2-11) and this relation changes at

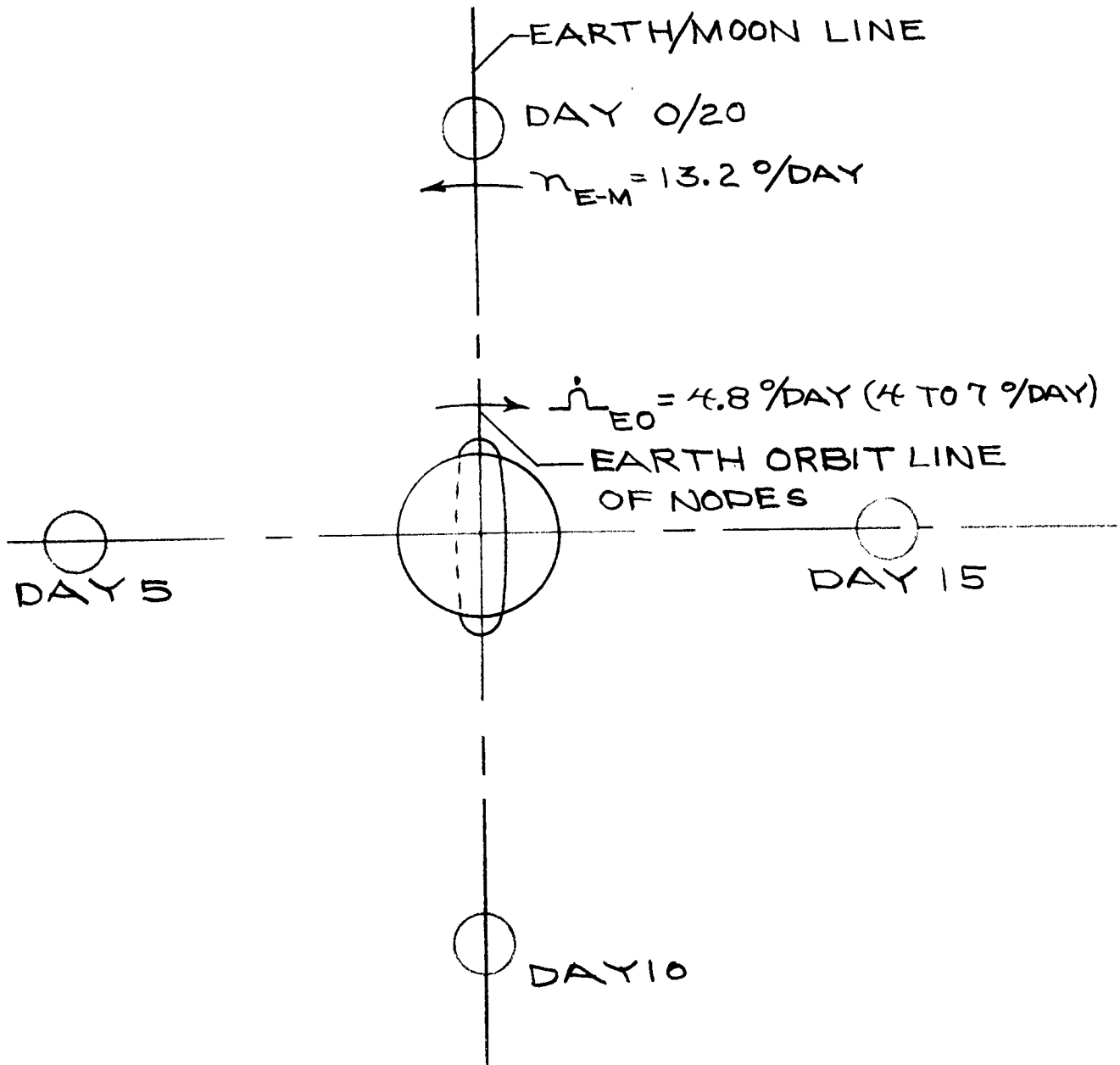

Fig. 2-11 Translunar Injection Alignment

a rate of 18 degrees/day ($55^\circ \times 262$ n.m. orbit). Consequently, a waiting time of up to 10 days for orbit alignment could be required. The alternative is to change the plane of the Earth orbit at a cost in the order of 36,000 ft/sec ΔV for 90 degrees. The use of 36 hour transfer ellipse would save about 60% of this ΔV for the 90 degree case, but this is still not a feasible solution. To avoid plane changes in Earth orbit for rescue vehicles, the missions should be planned to wait out the orbit phasing. The PTV flight time between Earth orbit and lunar orbit is in the order of 96 to 120 hours. Assuming the need for rescue would not arise until Lunar Orbit Insertion, 5 days from Earth orbit departure, the rescue vehicle in Earth orbit would wait another 5 days for the proper alignment. It can be argued that, since the fastest transfer time is still 2 days, an additional 5 days will not make that much difference. If the lunar crew can survive for two days, provisions for five additional days would not be difficult to provide. For lunar departures, the mission could be planned to coincide with the Earth orbit alignment for translunar insertion.

For rescuing a lunar crew as a result of a random incident, the response time for a rescue vehicle based in Earth orbit could be as much as 14 days. If this mode is planned, then provision must be made for the crew to survive for a minimum of 14 days.

2.5.3.2 Rescue Vehicle Based on the Surface of Earth

A dedicated vehicle on a launch pad on the surface of Earth has the advantage of the Earth's rotation (15 degrees/hour) to position it for alignment with the Earth-Moon line; i.e., the surface launched rescue vehicle has two opportunities each day to launch into a translunar injection orbit. The problems of launch, ascent, and orbit insertion of a vehicle capable of performing a rescue mission to lunar orbit requires further study before the question of rescue originating from Earth orbit vs. Earth surface can be resolved.

2.5.3.3 Lunar Orbit Alignment

As shown on Figure 2-12, the Earth orbit/Earth-Moon line alignment is not the only consideration in avoiding costly plane changes. The Right Ascension (RA) of the lunar orbit to the Earth-Moon line varies on a fourteen day basis. As shown in Figure 2-13 the approach asymptote of the lunar trajectory is not aligned with the Earth-Moon line but is at some angle in terms of the right ascension. To avoid the necessity of a plane change at lunar orbit insertion, the lunar orbit must have the proper angular relation to the approach asymptote.

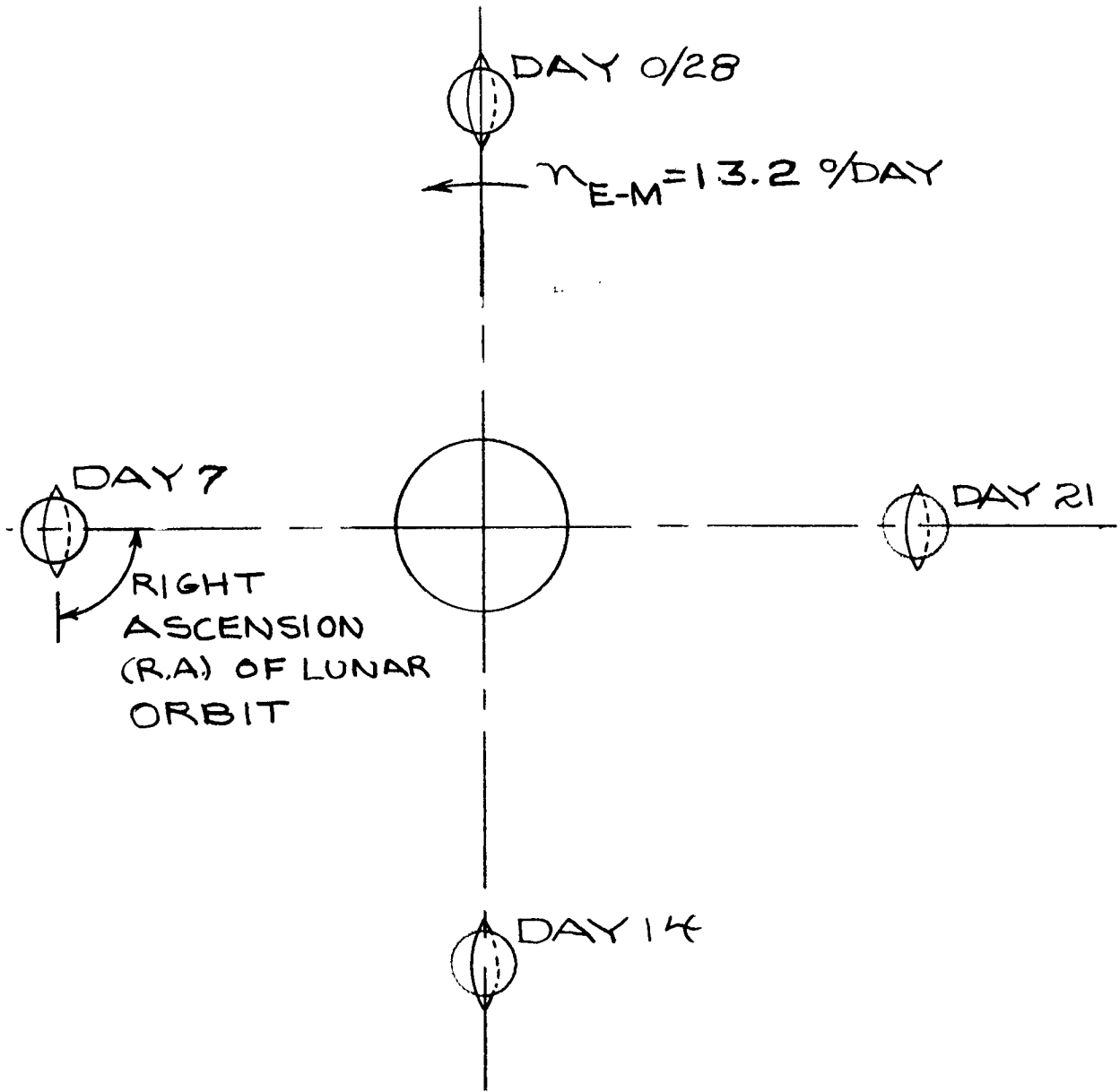

Fig. 2-12 Lunar Orbit Alignment

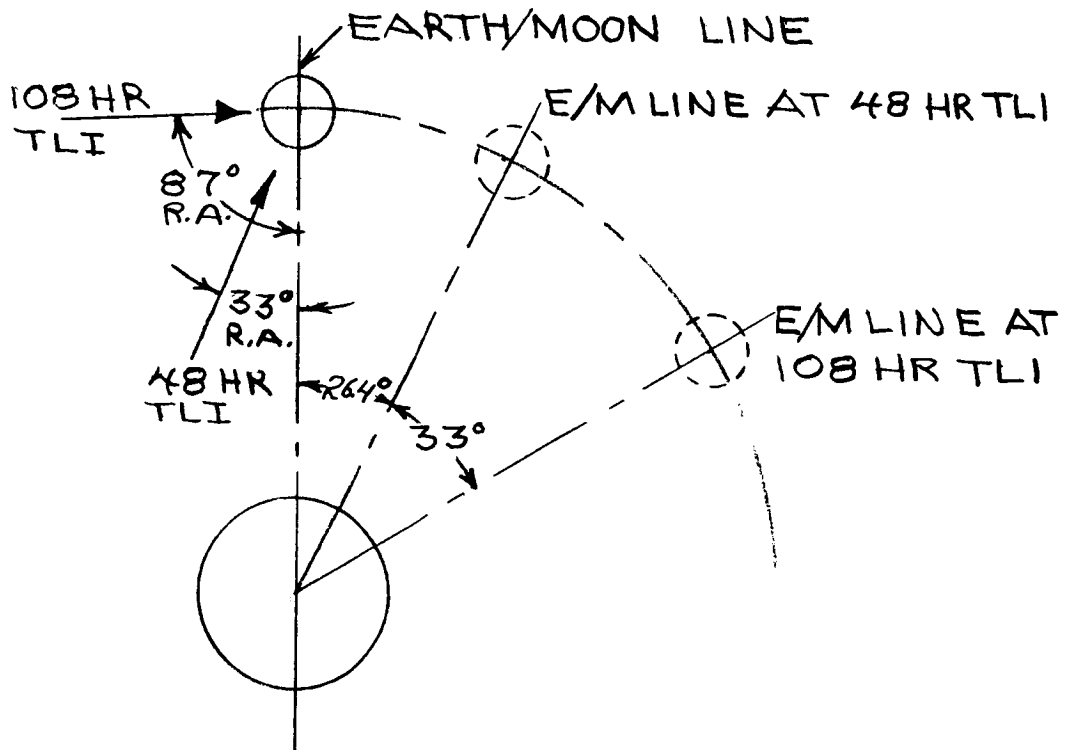

Fig. 2-13 Lunar Approach Asymptotes (Simultaneous Arrival)

The approach asymptote is a function of several factors, predominately the translunar flight time which determines the arrival velocity and position at the lunar sphere of influence.

At first glance, it would appear that varying the flight time, consequently the RA of the approach asymptote, may be a way of decreasing a plane change requirement at lunar orbit insertion, but closer examination shows that this method is quite limited. As shown in Figure 2-13 the approach asymptote will vary over a range of 54 degrees as a function of translunar flight time. However, certain delays for TLI are introduced.

In order to change the approach asymptote from 87° to 33° (Figure 2-13) the translunar injection must be delayed 60 hours (108 minus 48); a rather heavy penalty for a rescue mission. If the injection is not delayed by the difference in flight time, the result is self canceling due to the change in lunar orbit right ascension. This is illustrated in Figure 2-14 which shows the arrival conditions for a 48 and a 108 hour flight with the same (Moon's position) translunar injection time. The right ascension of the lunar orbit increases at the rate of $.55^\circ/\text{hr}$, while increasing the flight time increases the approach asymptote right ascension an average of $.9^\circ/\text{hr}$, for a net gain of $.35^\circ/\text{hr}$ or a total of 21 degrees for a 60-hour delay in arrival.

In view of the above, this approach is not practical. Consequently, the rescue vehicle may require the capability to correct a lunar orbit misalignment of up to 90 degrees.

2.5.3.4 Earth Based Rescue Requirements

The nominal Earth based rescue mission introduces the following approximate time and ΔV requirements:

Earth Orbit Alignment	10 days
Translunar Injection	10,000 ft/sec
Translunar Flight Time	60 hours
Lunar Orbit Insertion (90° plane change using 24 hour ellipse)	24 hours and 4,800 ft/sec
Phasing, Rendezvous, and Rescue	12 hours
TOTAL RESCUE TIME AND ΔV	14 days and 15,000 ft/sec

2.6 ESCAPE/RESCUE GUIDELINES FOR LUNAR ARRIVAL/DEPARTURE

The arrangement of personnel and equipment for the initial manning flight is quite different from the subsequent routine crew rotation flights. Consequently, two distinct sets of guidelines arise as given in the following.

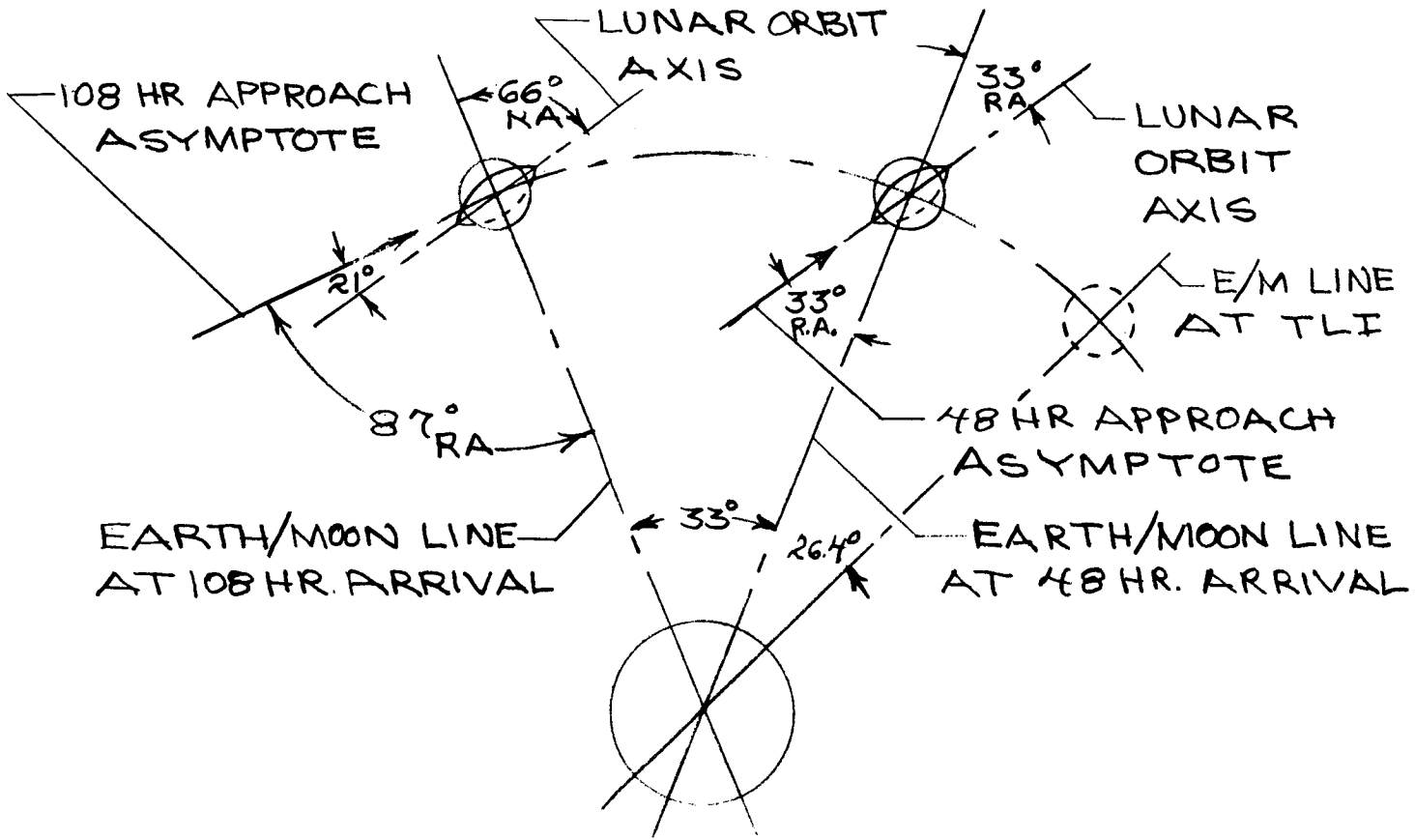

Fig. 2-14 Approach Asymptote/Lunar Orbit Alignment Vs. TL Flight Time (Simultaneous TLI From Earth Orbit)

The initial manning flight guidelines pertaining to the tug are for the initial tug only.

2.6.1 Escape/Rescue Guidelines for Initial Manning Flight

1. The initial manning flight should transport the crew to lunar orbit in a tug which is fueled and provisioned to make an autonomous escape from the Prime Transport Vehicle (PTV) and choose rendezvous with the Orbiting Lunar Station or return to Earth orbit.
2. Prior to lunar orbit insertion the tug must be manned and activated for immediate escape.
3. The guidance system of the tug must be activated and capable of warning the crew of any maneuvers that place them on a trajectory requiring escape.
4. The tug guidance and navigation system must be capable of generating the commands for the escape maneuvers.
5. The tug should be able to return to and rendezvous with the orbiting lunar station following an escape from the PTV.
6. The PTV must contain a redundant attitude control system capable of overcoming any tumbling sufficiently for the crew to escape in either the tug or crew compartment. In addition, a nuclear PTV should have an autopilot/attitude control system capable of holding the PTV in a stationary position long enough for the crew to escape to a safe radiation distance.
7. The PTV redundant attitude control system shall be activated and operated from the tug or crew compartment.
8. Standby rescue should be available from Earth during the initial manning flight, or else the tug should have the capability to return to Earth orbit on an autonomous basis.

2.6.2 Escape/Rescue Guidelines for Routine Crew Rotation Flights

1. The crew compartment of the Prime Transport Vehicle should have its own propulsion system (1000 ft/sec ΔV) including attitude control which will allow the crew to escape in the event of faulty lunar arrival or departure maneuvers. The propulsion system should have quick activation time coupled with long dormant storage life.
2. The crew compartment of the prime transport vehicle should contain an autonomous guidance and navigation (G&N) system capable of monitoring the effect of any maneuver in the lunar areas. This G&N system should be able

to generate commands for escape maneuvers including placing the compartment on a safe trajectory.

3. The crew compartment should have a communications system capable of signaling the station of the need for rescue.
4. The crew compartment should have aids, both electronic and visual, to allow a rescue vehicle to locate, track, and rendezvous.
5. During arrival and departure maneuvers the standby rescue tug at the station should be manned and activated in the event that rescue is needed.

SECTION 3
LUNAR ORBITAL OPERATIONS

Lunar orbit escape/rescue situations are related to the proposed hardware, its deployment, and operational utility. The proposed key hardware elements are the orbital station, space tug, prime transport vehicle (PTV) could contain either a chemical or nuclear propulsion unit, one or two tugs, or a self-sufficient crew compartment and cargo. A propellant depot is a possible additional hardware element; however, it is doubtful if its deployment would occur until well after initiation of the lunar program.

3.1 SITUATION DESCRIPTION

It is assumed that the advanced lunar exploration program starts with the injection of the unmanned orbiting lunar station into lunar orbit. In approximately 2 months the first manned flight occurs, using a prime transport vehicle (PTV), one or two tugs, and delivering the initial crew. After arrival in the lunar area the PTV injects into lunar orbit and completes rendezvous with the station. The crew then separates their tug from the PTV and docks with the station. The station is then activated, checked, and placed on operational status.

Regular and periodic logistics flights are then made between the Earth vicinity and the station, bringing up additional crews, lander tugs, and cargo. Surface landings will be made by the lander tugs at various sites. Each landing and scientific sortie is for a span of time of up to 28 days.

The orbital station can maintain a nominal manning level of approximately 8 crewmen. Typical station operations include the docking/undocking of tugs, unloading and loading cargo, station housekeeping and EVA activities in support of the station.

A propellant depot may be placed into orbit in the near vicinity of the station at some future date. This depot would act as a storage facility for various consumables and propellants and would service tugs for various missions. The range and position of the depot relative to the station has not yet been determined.

In the following paragraphs the operations and escape/rescue situations in lunar orbit are described. The references to Hazard Studies by number pertain to the studies presented in MSC-03977 from which requirements for escape and rescue were derived.

3.2 ORBITING LUNAR STATION OPERATIONS

The escape/rescue situations arising from the orbital station operations listed below are presented, their requirements are defined, and the escape/rescue alternatives are analyzed and evaluated;

- o Initial Manning and Activation
- o Routine Operations
- o EVA Activities
- o Deactivation

In conclusion the resulting escape/rescue guidelines for the lunar orbital station are listed.

3.2.1 Initial Manning and Activation (Refer to Hazard Studies 1 and 4)

The initial activation and manning of the orbiting lunar station is expected to occur after the unmanned station has been placed in the desired lunar orbit, has stabilized, and after remote systems status checks have been satisfactorily completed.

The first manned flight consists of a prime transport vehicle (PTV) and a payload consisting of initial cargo, a crew, and at least one and possibly two lunar tugs. The PTV propulsion can be either chemical or nuclear. The planned mission operation includes insertion into lunar orbit, rendezvous with the lunar orbital station, unloading of supplies, and station activation and checkout. For the purposes of this analysis it is assumed that the tug and cargo has successfully separated from the PTV and docked with the station. The tug separation from the PTV and docking with the station is covered in Section 3.3.1, Tug Operations Near Vicinity of Station.

3.2.1.1 Major Subsystem Failure - Station Inoperative

The failure of a critical station subsystem, including any backup and emergency capability could result in a decision to discontinue or even to abort the initial mission. As a result of the subsystem failure two immediate options are available to the crew:

- a. Remain at the station and await a flight from Earth with either repair or subsystem replacement capability.
- b. Abandon the station and return to Earth in the docked tug vehicle.

Under option (a) the crew could elect, depending on the station failure mode, to either remain in the station or in the docked tug. If necessary the tug could support the station, by means of a tug/station umbilical, in areas such as communications, station-keeping, attitude control, and perhaps data management so that a station failure would not necessarily result in total loss of capability. Such support could enable the crew to continue station activation while awaiting a repair flight from earth.

If the subsystem failure was of such a nature that the crew had to abandon the station, the docked tug should have sufficient capability to enable the crew to return to Earth orbit. In order to accomplish this return, the tug must have life support capability of at least seven days and a ΔV capability of 15,000 feet per second. The seven days allows 36 hours for phasing, plane change, and departure maneuvers (including a 24 hour elliptical plane change maneuver), 60 hour trans-Earth flight time, and a 3 day contingency for rescue in Earth orbit.

If the tug does not have the required ΔV capability (because of performance inadequacy or because of off-loading tug propellant to satisfy PTV payload restrictions), the crew must remain in the tug in lunar orbit until a PTV can either bring a repair crew from Earth to repair the station and enable continuation of the station activation mission or return the stranded crew to the Earth vicinity. Provisions for 14 days are required to await the arrival of a PTV from Earth orbit.

3.2.1.2 Life Support/Environmental Control Subsystem Failure

A failure of the station primary life support/environmental control subsystem alone would probably not seriously affect the station activation mission because of station design redundancy and the proposed two pressurized compartment design philosophy. Assuming that the failure mode is such that the entire station life support/ECS subsystem fails (including all backup capability) the crew could retreat to the docked tug and remain until repairs could be made or until a repair crew with replacement parts could arrive from Earth. An alternative is to abandon the station and return to Earth in the docked tug. The operational decision would be strongly influenced, of course, by the remaining tug life support/ECS capability with respect to the length of time required to bring a crew from Earth and to repair the failed subsystem.

3.2.1.3 Critical Failures

In a critical failure situation the station sustains severe physical damage that results in a sudden loss or deterioration of a critical capability, structural damage, and crew injury or jeopardy. Such a failure could be caused by a collision or meteoroid strike and could be accompanied by fire or an explosion. Sudden and rapid depressurization may also occur as a result of shrapnel, explosive force or meteoroid damage. Any serious or critical injuries will complicate personnel removal from the station and ingress into the docked tug.

Figure 3-1 presents some of the possible event sequences and alternatives that could result following this type of failure.

If a fire occurs, smoke will be produced, oxygen will be consumed in the combustion process, and noxious or perhaps even toxic gases will be produced or released. Emergency portable oxygen masks and supply bottles or pressure garments with a built-in portable oxygen supply would provide sufficient protection from smoke or gases and the effects of depressurization to enable crewmen to evacuate and perhaps seal-off the affected area or to traverse to the docked tug.

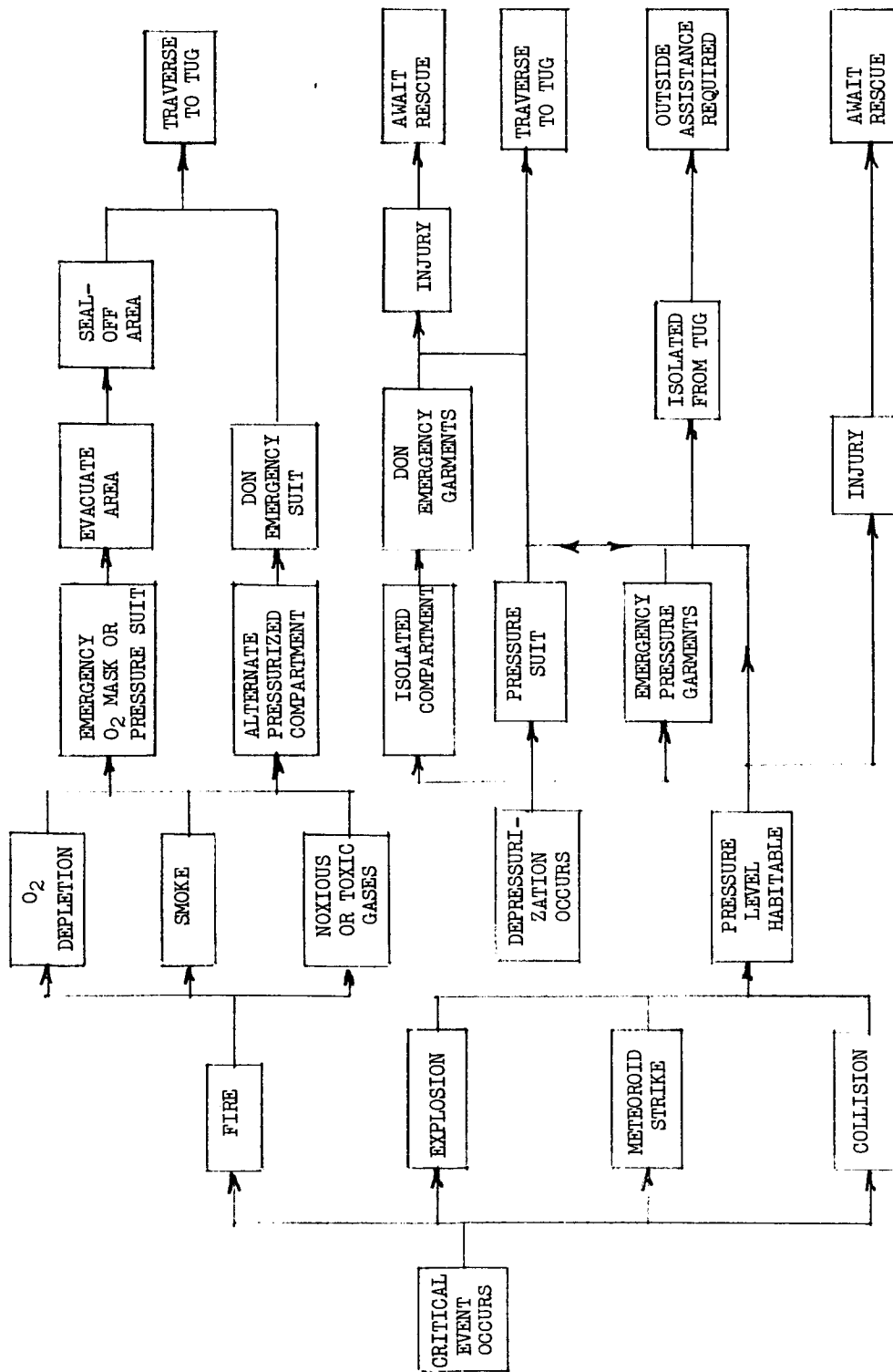

Fig. 3-1 Orbiting Lunar Station Critical Event Sequence

If the rate of oxygen depletion or production of smoke or toxic gases was so rapid that the crewmen could not traverse to the site of stored emergency gear or could not don and activate an emergency garment rapidly enough, perhaps due to an injury, the crewman could enter a second pressurized compartment that would provide a temporary safe haven. Any gases or smoke that filtered into the compartment with the crewmen could be cleared by a self-contained life support/ECS subsystem. The crewman would then have sufficient time to don and activate emergency gear. Such a compartment should be separate but interconnected and have self-contained and independent life support, environmental control, power source, lighting, communications, first aid supplies, emergency garments and a pressurized stretcher. In addition, provisions should be made to convert the local ambient pressure in the compartment in a programmed manner from the station pressure to suit pressure in order to provide a denitrogenization capability and thereby decrease the span of time required to don pressure suits or emergency garments.

An emergency situation involving an explosion, meteoroid strike or a collision would probably be complicated by depressurization. A crewman already in a pressure suit would, of course, have no problem and could proceed directly to the docked tug. If the crewmen were not in pressure suits, an alternative would be to don emergency pressure garments and immediately traverse to the docked tug. A second alternative, depending on the depressurization rate, would be for the crewman to enter one of the alternate pressurized compartments previously mentioned.

Once in an alternate compartment the crewman could either await rescue or could don an emergency pressure garment, depressurize the compartment to the local station ambient pressure level and translate to the tug. If injuries prevented this procedure, the crewmen would have to retain a shirtsleeve environment in the compartment and await rescue. The rescue crew would then proceed to the compartment through the depressurized station and would require access into the pressurized compartment through an airlock. If the compartment airlock is inoperative, or if there was no airlock available, a portable airlock would be

required. After entering the pressurized compartment the rescue crew would be able to either assist injured crewmen in donning emergency pressure garments and in traversing to the tug or could place the crewmen in the pressurized stretcher for transporting to the tug.

The alternate compartment and its subsystems should be sized for the normal station crew complement (current thinking is 8 crewmen). Storage space would be needed for consumables sufficient for 14 days and emergency equipment such as oxygen masks, portable oxygen supplies, and emergency pressure garments. In addition, dedicated equipment is needed in the areas of power, first aid supplies, communications and environmental control.

A properly configured and sized compartment would be quite large, perhaps as much as 150 feet² of floor space and a total of 1,000 feet³ of volume as a minimum. Even one compartment will penalize the station in terms of space, weight, resources, data management, and maintenance and repair, unless it can perform a normal function for routine operations. One possible solution is to use the crew sleeping quarters as the alternate compartment. In addition to the obvious potential savings in space and weight there could be an added advantage in that 1 or 2 crewmen could, as a minimum, always be in the sleeping quarters/alternate compartment and immediately available for rescue work.

In order to ensure the availability of a rescue crew and immediate access to pressure suits, two crewmen should remain in the docked tug at all times during the station activation period. In this manner, mobile and suited crewmen would be immediately available for rescue work if required.

3.2.1.4 Critical Failure - Tug Inoperative

A critical failure could result in major damage to both the station and all docked tugs. In this situation critical personnel injuries are probable, coupled with rapid depressurization and loss of environmental control. The only available temporary safe haven would be station alternate compartments.

It is conceivable that one or more crewmen might be able to traverse to and enter an alternate compartment and hence extend his survival time.

No rescue crew would be available in the lunar area and no means of escape from the station would exist since the tug is presumed to be inoperative. A survival time of 14 days (refer to Table 3-1 for derivation of the 14-day span) would be required in order to allow for a rescue crew, based in the vicinity of the Earth, to arrive at and enter the seriously damaged station, search for and find any crewmen that are still alive, and remove them to the rescue vehicle. It follows that any station pressurized compartments must have the capability for communicating with the Earth vicinity and must have life support capability for 14 days, including a contingency allowance to compensate for rescue crew activities after their arrival at the station.

Table 3-1
RESPONSE TIME FOR RESCUE OF CREW IN LUNAR ORBIT
BY A RESCUE VEHICLE FROM EARTH ORBIT

Event	Time Span	Accum. Time	Remarks
Phasing	10 days	10 days	Maximum time for Earth orbit/ Moon alignment
Trans Lunar Injection	--	--	--
Coast	60 hr	12.5 days	Relatively fast transfer
Lunar Orbit Insertion	24 hr	13.5 days	Elliptical Plane Change Maximum 90°
Phasing, Rendezvous, Docking, & Rescue	12 hr	14 days	Nine hours for entrance and rescue

3.2.1.5 Radiation Environment Effects

The presence of a radiation environment in the orbiting lunar station can occur as a result of a failure in on-board nuclear reactor power systems or

other types of nuclear systems. The possibility of radiation contamination must be taken into account in the design and performance requirements for masks, pressure suits, emergency pressure garments, pressurized stretchers and station pressurized compartments. Radiation level measurement instruments and sensors with appropriate alarm and display systems must be designed into the tug, station, and any potential Earth-vicinity-based rescue vehicle. In addition, portable instruments must be available for use by a rescue crew to measure and monitor local ambient radiation levels during a rescue operation. Operation and interpretation of these instruments must be included in the safety training of all crew members.

Tugs used in the lunar area must have the on-board capability and trained crewmen for the emergency treatment of radiation sickness.

3.2.1.6 Tumbling Orbiting Lunar Station

There is a high probability that the orbiting lunar station will achieve a tumbling mode in the event of a critical failure, particularly if depressurization results.

In general, escape from a tumbling spacecraft is more desirable than for a rescue vehicle to either attempt to arrest the tumbling motion or to phase and dock with it. Refer to Appendix C for a more complete discussion and analysis of escape/rescue from a tumbling spacecraft. A backup, emergency, manually controlled attitude control system would permit arresting station tumbling motion or at least reducing the rate to a level that would permit a rescue vehicle to dock with the station.

3.2.2 Routine Operations (Refer to Hazard Study 3)

Following activation and checkout the lunar orbital station will be placed on a routine operational status. The escape/rescue situations analyses that were presented in Section 3.2.1, Initial Manning and Activation, also apply to the station routine operations phase and will not be repeated here.

Lunar surface missions will begin soon after station activation. These sites will be considered as a potential base for a rescue vehicle.

3.2.2.1 Orbiting Lunar Station as Primary Rescue Operations Base

The relatively large store of consumables, flexibility of life support facilities, and advantageous orbital trajectory make the orbiting lunar station the leading candidate as the primary lunar escape/rescue operations base and safe haven.

It follows that the station design must be capable of accommodating the assigned station crew, any additional crewmen being rotated or transferred, plus any additional crewmen who might be using the station as a safe haven following an escape/rescue operation.

In order to provide surface escape/rescue capability, the station orbit trajectory must conform to two general requirements:

- a. The station altitude must be high enough to provide a suitably large area of surface line-of-sight coverage for station/surface communications and visual observation for tracking purposes.
- b. The station inclination must be equal to or greater than the latitude of any surface site or exploration party traverse track in order to minimize the amount of plane change required by an escape/rescue mission.

3.2.2.2 Escape to Lunar Surface Base

An emergency in lunar orbit calling for rapid transfer to a safe haven to obtain medical aid might call for escape to a lunar surface base. If no base exists, escape to the lunar surface would only compound the problems.

Deorbit and touchdown of the escape tug at any specific site on the lunar surface will probably require phasing and an orbit plane change. In any

case, the exact location of the desired site must be known as well as the specific tug ephemeris. If a station hazard has caused the need to escape it is possible that failures resulting in depressurization or in a run-away attitude control or stationkeeping reaction control nozzle may have altered the station velocity vector. A station ephemeris or tug navigation update would then be required. The tug must have sufficient on-board capability to make a 90° plane change and to descend to the lunar surface in order to touchdown at surface base site. If the tug performance capability is marginal, and if a 90° plane change change is necessary, the velocity requirement could be reduced from approximately 14,850 to 12,100 ft/sec by injecting into a 24 hour period ellipse and making the required plane change maneuver at apolune.

3.2.2.3 Orbiting Lunar Station Rescue from the Lunar Surface

The lunar surface base will include a standby lunar landing tug to be used as an escape/rescue vehicle. In addition, lunar lander tugs used for solo surface exploration sorties could, by aborting their mission, return to orbit to perform a rescue operation.

Table 3-2 presents a rescue time sequence for an orbiting lunar station rescue operation originating at either a lunar lander tug surface exploration sortie site or the lunar surface base.

With no plane change required, the rescue tug needs approximately 6690 ft/sec

ΔV capability to launch from the lunar surface, inject into the station orbit, phase, and rendezvous and dock with the station. If a 90° plane change is required, there are two available choices: Refer to Appendix A for additional information concerning ascent maneuvers and plane changes.

- a. Make the plane change at station orbit altitude. This is a minimum time maneuver, but will require approximately 7550 ft/sec of additional impulse.
- b. Make the plane change at apolune of a 24 hour period ellipse for an additional impulse requirement of approximately 4800 ft/sec.

Table 3-2

TIME SEQUENCE FOR ORBITAL RESCUE MISSION FROM LUNAR SURFACE

Sequence	Time Span (Min)	Cum. Time (Min)	Remarks
Emergency Occurs	-	-	
Communications to Lunar Surface Base	75	75	Must be Able to Communicate with Earth for Assured Link to Lunar Surface Base
LSB Originates Rescue Operation	15	90	Approval from Earth Vicinity May be Needed
Rescue Crew Alerted	15	105	Crew May be on EVA Traverse Operation in Near Vicinity of Base
Rescue Crew Reports to Base	120	225	EVA Traverse Range at Least 2 Hours from Base
Rescue Operation Briefing Meeting	15	240	Rescue Operations Plan Agreement
Crew Preparation	30	270	PLSS Recharge or Change, and Equipment Selection
Tug Activation and Checkout	10	280	Tug Readiness Checks Previously Accomplished in Parallel with Other Sequence Checks
Launch and Orbit Maneuvers	300	580	Direct Ascent with Any Required Plane Change Made at Station Orbit Altitude
	1440	1720	Direct Ascent with Any Required Plane Change Made at Apogee of 24 Hour Period Ellipse
Rendezvous and Dock	70	650 1790	May Require Rendezvous and Dock with Uncooperative Station, Requiring Specialized Equipment
Rescue Operation in Station	60	710 (12 hrs) 1850 (31 hrs)	If Station Entry is Difficult, Could Require Considerably Longer Time for this Sequence Step
Rescue Accomplished	-	-	Tug is Temporary Safe Haven and Could Remain in Orbit Awaiting PTV Flight from Earth Vicinity

Thus the minimum ΔV requirement for ascent, injection into the station orbital altitude and 90° plane change, varies between a minimum of 11,490 ft/sec and 14,240 ft/sec depending on the selected orbit plane change maneuver technique.

There are several alternatives available after the stranded station crew survivors have been placed in the rescue tug (temporary safe haven) and the tug has reached an orbital position at a safe range from the station:

Return to Lunar Surface Base

This option requires an additional ΔV of 7300 ft/sec if no plane change is required and approximately 14,850 ft/sec if a 90° plane change is required with the plane change maneuver performed at station orbital altitude. If the plane change is performed at the apolune of a 24 hour period ellipse the ΔV requirement drops to approximately 12,100 ft/sec. In either of the above outlined cases it is doubtful if the tug capability would be sufficient. For example, even assuming that any required plane changes were made with a minimum impulse maneuver, the following tug total ΔV capability would be required:

Maneuver	ΔV
Original Tug Descent to Lunar Surface Base	7,300 ft/sec
Station Rescue Mission-Ascent	12,100 ft/sec
Tug Descent to Lunar Surface-with minimum impulse plane change	12,100 ft/sec
Total	31,500 ft/sec

Take Crew to Earth Orbit

To return to Earth orbit from lunar orbit will require approximately 15,000 ft/sec ΔV including a 90° , 24 hour, elliptical plane change. This ΔV requirement in addition to the original descent and rescue mission ascent (see table above) exceed the probable capability of the tug without refueling. If propellant is available in lunar orbit, the return to Earth orbit is feasible.

Recommended Mode

The recommended mode is for the tug to remain in lunar orbit, after completing a station rescue operation until a PTV can arrive from the Earth vicinity. The stranded crew would then be transferred to the PTV for Earth return. The tug could refuel from the PTV and return to the lunar surface base to support crewmen left on the surface.

The tug life support system and consumable stores must be sufficient to support both the rescue crew and the stranded crew until the PTV arrives from the Earth vicinity and completes rendezvous, docking, and transfer of crewmen.

It follows that both the lunar surface base and the Earth vicinity must function as bases in support of potential orbiting lunar station rescue needs. The LSB, with a rescue response time of 12 to 31 hours, serves as the more immediate response base, with the PTV based in the Earth vicinity supporting the rescue tug and completing the transfer of the stranded crew to a permanent safe haven. The PTV response time is 14 days. If response time is not critical the Earth orbit based PTV could function as the rescue vehicle with the LSB based tug on an alert status at the LSB until transfer of the stranded crew into the PTV has been accomplished.

3.2.3 EVA Activities (Refer to Hazard Study 7)

Hazard Study 7 - Orbital Extra Vehicular Activity (EVA) presents requirements for escape/rescue for several different extra vehicular situations. For escape/rescue analysis purposes these situations can be divided into two general categories: (1) the crewman on EVA is attached to the orbital station (or some other spacecraft) by means of a tether, umbilical, or both, and (2) the crewman is in an astronaut maneuvering unit (AMU) or cherry picker.

Escape from an extra vehicular situation implies that the crewman has the capability to return to the station or tug (safe haven) without outside assistance. Rescue implies that the crewman on EVA cannot reach a safe haven unless outside assistance is supplied.

3.2.3.1 Extra Vehicular Crewman Attached to an Orbiting Lunar Station

Possible extra vehicular missions for a crewman on a tether include:

- a. Routine inspection of critical exterior equipment such as thermal radiators, antennas, or solar arrays
- b. Maintenance - both planned and unplanned
- c. Replacement of exterior components such as RCS thrusters
- d. Servicing science equipment

There are several rescue situations that could occur while carrying out functions similar to the above. During these operations the crewman is continuously on a tether. He can either be on a backpack or be attached by a "short" umbilical to a locally placed connection for life support, communications, environmental control, and power. These external connections should be strategically located both in equipment areas needing planned periodic maintenance attention and also close to equipment needing attention in the event of a malfunction or failure.

If station or tug equipment clearances preclude the wearing of a complete backpack, the crewmen should at least have a minimum 90-minute duration emergency life support system. This duration is a function of the probable rescue response time, based on Table 3-3 plus a contingency factor. An emergency life

Table 3-3

EVA RESCUE TIMELINE SEQUENCE

Sequence	Rescue Crewman in Station		Rescue Crewman Outside Station		Remarks
	Time Span (min)	Cum Time (min)	Time Span (min)	Cum Time (min)	
Emergency Occurs	-	-	-	-	-
Communication to Rescue Crewman	1	1	1	1	Two Modes: (a) Normal Communication Voice Band (b) Emergency Communication Voice-On Rescue Carrier, RF Beacon, Flashing Light
Denitrogenization	180	181	-	1	Denitrogenization on Pure O ₂ with Exercise
Egress Through Airlock	24	205	-	1	
Traverse/Pickup Crewman and Return to Airlock	30	235	30	31	
Ingress Through Airlock	24	259	24	55	
TOTAL	259		55		Recommendation: Suited Rescue Crewman Outside Station During EVA

support system is needed in case the umbilical connection is interrupted either as part of the emergency situation failure mode or is made necessary in order to effect timely rescue or extrication from a failed structural area.

In general there are two rescue modes as a function of whether the rescue crewmen are located inside the station in a shirtsleeve environment or located outside the station in full space environment.

Table 3-3 presents a comparison of the time span required to reach the immediate location of a stranded extra vehicular crewman who is in need of outside assistance. The crewman in the station is in his suit, with helmet off, and in the nominal 14.7 psi station atmosphere. The crewman outside the station is suited, has a backpack, and has an umbilical connection to the station. A quick disconnect is needed so that the extra vehicular rescue crewman can disconnect the umbilical at his suit to provide maximum maneuverability during the rescue operations. By remaining on umbilical until an emergency occurs the full backpack metabolic capability is available.

The EVA crewman can ordinarily "sound-the-alarm" by means of his standard voice communications link. However, a power loss, illness, or injury could preclude this capability. If so, the crewman should have a separate, self-contained voice communications link operating on a carrier that is reserved for escape/rescue emergency use. In addition, since the crewman may not be able to talk, a self-contained RF beacon and flashing light located on the crewman's helmet should be designed into pressure suits. This emergency equipment should be capable of being activated manually by the crewman and should also be automatically activated in the event of such conditions as:

- a. Suit power loss
- b. Umbilical failure
- c. Activation of emergency oxygen system
- d. Suit pressure decaying below some minimum level
- e. Failure of normal communications system

The pressure suit emergency oxygen system must have an operational capability at least as long as the rescue response time plus a contingency allowance. Ninety minutes is a recommended minimum based on the 55 minutes rescue response time of a crewman stationed outside the station. A more productive alternative to having a rescue crewmen standing by outside the station during EVA is to use the buddy system for EVA activities, i.e., conduct all EVA activities with a pair of crewman. Precautions would have to be taken that they were not simultaneously exposed to the same hazard.

3.2.3.2 Crewman Separated from Station

In this Extra Vehicular mode the crewman is not attached to the station, but instead uses an astronaut maneuvering unit (AMU) to translate around the station. The AMU may range in design complexity from a simple handheld propulsion device or may weigh as much as 100 to 200 lbs. and include capability for propulsion, attitude control, communications, power and life support. Use of an AMU would be necessary under the following typical types of conditions:

- a. Transport of a quantity of bulky or heavy tools or supplies
- b. A working platform is needed
- c. Translation across short distances of open space between station hardware elements was needed

The AMU would require redundancy and fail/safe design philosophy similar to that of the station or tug. The crewman would need the 90-minute capability emergency O₂ system and emergency communications capability previously described. The rescue crewman would require an AMU with at least the propulsion, ΔV , and other capability of the AMU assigned for use by the Extra Vehicular crewman. The rescue assigned crewman would also require line-of-sight direct observation of the Extra Vehicular crewman and therefore might have to maneuver his AMU to successive positions around the station.

One of the critical rescue situations occurs when the Extra Vehicular crewman is drifting away from the station. He may be in an AMU or free floating. This situation could occur as a result of injury or sickness with the crewman unable to control the AMU, could result from a failure of a critical AMU capability, or

could result as a planned maneuver in the unlikely event of a catastrophic station failure during the EVA mission.

Table 3-4 presents a summary of the expected orbital motion of an EVA crewman drifting away from the station as a result of an undesired ΔV increment. This increment could result from a propulsion, attitude control, or power failure.

Table 3-4

EXTRA VEHICULAR CREWMAN FREE FLOATING MOTION

Motion Direction	Return to Station	Return Time Span	Remarks
In Track	Once per Orbit	120 min	Possible Collision with Station
Cross Track	Twice per Orbit	60 min	Possible Collision with Station
Radial	Once per Orbit	120 min	Possible Collision with Station. If Added Velocity Vector is in Downward Direction Surface Impact is Possible

If the drifting velocity is relatively low, the backup rescue crewman and AMU should be able to reach the drifting crewman and return him to the station. If the velocity is high and the drifting crewman reaches a range beyond the safe operating range of the rescue AMU, several alternatives are available:

- a. Wait until the drifting crewman's orbit trajectory returns him to the vicinity of the station
- b. Use docked tug to chase and pick up drifting crewman
- c. Use station velocity capability to chase and pick up drifting crewman
- d. Provide the rescue AMU with upgraded capability

The recommended approach is to provide the rescue AMU with the capability to achieve 150 ft/sec velocity with respect to the station to catch the drifting crewman and then be able to return to the orbiting lunar station. In turn, the

AMU used for normal EVA activities should be limited to a total ΔV capability of approximately 100 ft/sec. Thus, the rescue AMU, with a total ΔV capability of approximately 400 ft/sec, would be able to chase, catch, and return the drifting crewman even if his total AMU velocity capability were expended in a runaway propulsion failure. If the total ΔV capability of the AMU were limited to 70 ft/sec, at 60 nm altitude the AMU would not be able to get on a trajectory that would impact the lunar surface.

1. Tumbling Crewman

A guidance system failure, attitude control, failure, or runaway reaction control nozzle could result in a tumbling AMU and crewman. (Refer to Appendix C for details on tumbling.) Rescue of the crewman requires that the tumbling motion be stopped. No satisfactory means is presently known for stopping the tumbling motion of body in space by another spacecraft. It is therefore recommended that the Extra Vehicular crewman in a tumbling AMU have available some means for stopping any tumbling motion without outside assistance.

The crewman would have available the lunar surface, the station or other spacecraft vehicle, and the Stars and Earth for use as a visual reference in determining his relative orientation and tumbling direction. Once the tumbling direction was determined an emergency corrective reaction nozzle could be used to stop or at least to reduce the tumbling motion to a manageable level. This emergency jet could consist of clusters of manually activated solid motors oriented along the AMU [†] 3 principle axes. By firing one corrective jet from a cluster at a time the magnitude and duration of the corrective velocity vector could be controlled. Also, deceleration forces on the crewman would be minimized by using lower thrust-level motors with low thrust-to-weight ratios.

If the crewman were separated from the AMU, in a free drifting mode with a tumbling motion, a hand-held jet nozzle (probably cold gas) could be used to arrest the tumbling motion.

2. AMU Propulsion Failure

An AMU propulsion failure could result in a shorter than desired propulsion burn or in no burn. As a result the crewman could be stranded and unable to return to the desired station location, he could be on a collision course with the station, or he could be on an escape trajectory. The escape or free floating trajectory has been previously covered in this section. If the crewman was unable to return to his point of origin, the rescue crewman and AMU would simply move out to the stranded crewman and return both crewman and AMU to the desired location.

If the EVA crewman was on a collision course with even a relatively low velocity in feet per second, contact with the station would probably occur prior to arrival of the rescue crewman and AMU. It follows that the EVA crewman must take some type of corrective action to avoid a collision. The EVA crewman could use the backup emergency attitude control jets used to stop AMU or crewman tumbling motion to null out a collision velocity vector or at least to reduce it to a relatively harmless level. The same jets could be used to roughly control the AMU until the rescue AMU arrived.

3.2.3.3 Pressure Suit Tear

A pressure suit tear poses two potential, difficult rescue situations: (1) a critical drop in suit static pressure, and (2) exhaustion of either or both backpack and emergency oxygen supplies. Even if the EVA crewman is attached to the station oxygen supply by an umbilical, a suit tear could cause a critical and even fatal suit static pressure drop. In this circumstance, the survival time will be a matter of seconds or minutes at best, thus making rescue marginal and escape out of the question.

If the suit tear could be repaired or sealed off, survival could probably be extended. Another possibility is to provide a pressure garment or bag which could be unfolded/deployed quickly around the crewman and sealed. The oxygen escaping from the suit tear would fill the garment and thereby provide a satisfactory static pressure level. An exhaust pressure relief valve then could maintain the static pressure and composition within acceptable limits during the rescue operation.

3.2.4 Orbiting Lunar Station Deactivation

Deactivation of the orbiting lunar station can result in escape/rescue situations similar to those occurring during initial station activation. There will be, however, certain differences as follows:

- a. The lunar surface base may be operational during station deactivation
- b. Deactivation involves turn-off and securing of equipment whose functional status is well known

Following station deactivation the crew could enter a docked tug, transfer to a prime transport vehicle (PTV) and return to Earth orbit.

Refer to Table 3-5 for a summary of the following paragraphs.

Table 3-5

ORBITING LUNAR STATION DEACTIVATION ESCAPE/RESCUE SITUATIONS

Situation	Functional LSB Available	No LSB Available	Remarks
Major Station Subsystem Failure	Option of Escaping to LSB or to Earth Vicinity	Escape to Earth Vicinity or Wait For Rescue Flight From Earth Vicinity	Can Wait in Either Docked or Orbital Tug
Critical Failure-Tug Operational	Same as Above	Same as Above	Deactivation of Pressure Compartments Should Occur Last
Critical Failure-Tug Not Operational	Option of Rescue From LSB or From Earth Vicinity	Rescue From Earth Only	Same as Above

3.2.4.1 Subsystem Failure on Orbiting Lunar Station

Failure of a major subsystem, including life support and environmental control, will result in the crew proceeding to the docked tug to either return to Earth in the planned manner or to complete station deactivation in pressure suits, if necessary.

3.2.4.2 Critical Failure of Orbiting Lunar Station

The same option available during station activation are also available during deactivation with the possible exception of the existence of a functional lunar surface base (LSB). A functional LSB could support either escape or rescue. If the LSB has previously been deactivated, the Earth vicinity serves as the potential escape or rescue base in the manner previously discussed in Section 3.2.1.

3.2.5 Escape/Rescue Guidelines for an Orbiting Lunar Station

The following escape/rescue guidelines are proposed for operations at the orbiting lunar station:

1. A dedicated rescue vehicle should be maintained in the Earth vicinity during lunar orbital station activation and deactivation. The vehicle and crew must be on a ready-alert status with a total response time less than the probable survival time of the stranded crew. A ΔV capability of 30,000 ft/sec and a response time of 14 days from alert to rescue are required.
2. During routine station operation a critical emergency that makes it impossible for the station crew to use docked tugs for escape will result in a need for rescue either from the lunar surface or from the Earth vicinity. Due to the shorter response time (9 to 35 hours from lunar surface versus 14 days from Earth orbit), the initial rescue should be made by a surface based tug. After the rescue is completed, the rescue tug will have to remain in orbit in the general vicinity of the station until a supporting rescue vehicle can arrive from the Earth vicinity.

In addition to picking up the stranded station crew the rescue vehicle from the Earth vicinity must refuel the tug for its return to the surface and the continuation of its interrupted mission. Note that a surface based tug that is used for a station rescue mission will probably not have sufficient remaining ΔV capability to either return to a lunar surface site or to reach Earth orbit.

3. At least two crewmen should remain in the docked tug during both station activation and deactivation as a dedicated rescue team.

4. Alternate pressurized compartments must be available in the station to provide crew members a temporary safe haven. These compartments must be self-contained with respect to the station subsystems and must, as a minimum, include the following capabilities:

- a. Life support
- b. Environmental control
- c. Electrical power
- d. Communications with Earth vicinity, tugs whether docked or orbital, PTV whether in lunar area or between Earth and Moon, lunar surface sites, and to rescue crews inside the station
- e. Lighting
- f. Airlock into station interior
- g. Emergency equipment
- h. Operable by one crewman whether injured or in good health
- i. Atmospheric filters and atmospheric recirculating capability to clear any contaminants that might enter with a crewman
- j. Instrumentation displays both in the compartment and outside to aid the rescue crewmen in determining conditions in the compartment
- k. The life support system must include capability to reduce the compartment ambient pressure and to control the mixture ratio of O_2 to any inert diluent gas

5. Emergency portable oxygen masks and supply bottles and pressure garments with a built-in portable oxygen supply should be strategically located throughout the station.

6. The orbiting lunar station design must provide a means for the crewmen to find their way to emergency gear, alternate pressurized compartments, or docked vehicles under extreme conditions of smoke, lighting, motion, or toxic gas.

7. The alternate pressurized compartment communication system must include the capability for the rescue crew and stranded crew to converse regardless of the ambient atmospheric conditions in the compartment and in the station.
8. The orbiting lunar station alternate pressurized compartment equipment must include first aid supplies, portable oxygen masks and pressure garments with built-in portable oxygen supplies, and pressurized stretchers for moving injured men who cannot don protective garments or pressure suits.
9. The following types of emergency equipment must be available for use by station crewmen for rescue purposes:
 - a. Oxygen masks and portable O₂ supplies
 - b. Pressure garments with built-in O₂ supplies
 - c. Lighting equipment
 - d. Pressurized stretchers
 - e. Radiation monitoring equipment
 - f. Portable airlock (including equipment for attaching the airlock and cutting through a wall or bulkhead)
 - g. First aid supplies
10. The alternate pressurized compartments must provide survival capability for a span of time greater than the Earth vicinity based rescue vehicle response time. It is estimated that this survival time should be 14 days.
11. The possibility of radiation contamination must be taken into account in the design and performance requirements for all emergency gear including pressure suits and backpack units.
12. Crew safety training must include operation of all emergency equipment and compartments as well as the interpretation of radiation monitoring instrumentation.
13. Emergency first aid kits must include the capability for the treatment of radiation sickness and crewmen must be trained to recognize and treat exposed crewman.

14. An emergency, backup, manually controlled attitude control system is needed to arrest station tumbling motion or at least to reduce it to a level that permits tug docking and undocking operations.

15. The orbiting lunar station is the leading candidate for use as the primary lunar area escape/rescue base and safe haven. It follows that the station must be able to accommodate the assigned station crew, crews being rotated including surface crews, plus any crewmen using the station as a safe haven following an escape/rescue operation.

16. The orbiting lunar station orbit altitude must be high enough to provide a suitably large area of station-to-surface line-of-sight coverage for communications and tracking purposes. A minimum altitude of 60 nm is recommended.

17. The orbiting lunar station orbit inclination must be equal to or greater than the latitude of any surface site or exploration party traverse track in order that escape/rescue operations could be carried out with no requirement for a plane change.

18. In order for the tugs based at the orbiting lunar station to conduct escape/rescue operations, the station ephemeris must be known at all times. This knowledge will provide a precisely known point in space from which the tug ephemeris, in turn, can be computed.

19. The rescue tug in lunar orbit must be provided with navigational updates after making plane changes or other orbital maneuvers that introduce significant errors into the tug guidance system. The orbiting lunar station may be required to provide these updates.

3.3 LUNAR ORBITAL TUG OPERATIONS

In this section escape/rescue alternatives are considered for lunar tug operations in the near vicinity of the orbiting lunar station and for lunar tug operations on solo missions. Included in the latter are lunar surface sorties and logistic flights. The concluding section lists the escape/rescue guidelines for lunar tug operations.

3.3.1 Tug Operations Near Vicinity of Orbital Station (Refer to Hazard Study 5)

Tug operations in the near vicinity of the orbiting lunar station should consist primarily of the following:

- a. Short orbital transfer of 5 nm or less
- b. Rendezvous and docking with the PTV, orbital station and propellant depot
- c. Transfer of cargo to and from the station
- d. Orbital station maintenance, repair, and assembly
- e. Refueling from either the PTV or from a propellant depot

The tug will probably always be manned whenever it is performing a mission or operation. The nominal crew should consist of not less than 2 men. At least 2 tugs should always be in the near vicinity of the station. One tug should be fully serviced, with a full load of propellants, life support and other expendables, and will be identified as a dedicated escape/rescue vehicle. The tug used for orbital operations may be off-loaded and, depending on its ΔV and thrust-to-weight-ratio requirements, could be configured with only a crew compartment and intelligence module.

3.3.1.1 Orbital Tug Unable to Complete a Rendezvous and Docking Operation

The failure of tug equipment such as the docking mechanism, docking sensors, attitude control system, etc. could result in the tug being unable to complete a rendezvous and docking operation. Survival time would not be an immediate problem since the tug life support/environmental control system would not be affected. Communication with either the PTV (if still manned) or the orbiting lunar station should be no problem unless the tug antenna location and type, and tug aspect angle with respect to the station results in RF interference. The use of several omni antennas for short range operation would preclude these types of communications difficulties.

If the stranded tug docking mechanism has failed, external attach points would be needed to provide a positive and rigid attachment between the stranded and rescue tug for maneuvering purposes.

3.3.1.2 Loss of Tug Electrical Power

The loss of all electrical power will result in the loss of all tug functions including the critical ones of communication, life support, environmental control, attitude control and propulsion. The tug will drift as a function of any velocity vector dispersions existing at the time of power failure. In addition, the tug will slowly tumble as a function of any residual vehicle torques.

Refer to Fig. 3-2 for the sequence of events related to life support. If a shirtsleeve environment exists in the crew compartment at the time of the emergency the crew and any passengers could use oxygen masks and await rescue. If the ambient pressure decays, the crew would be forced to don pressure garments or suits. If the crew were already in pressure suits, they could simply await rescue.

In a situation with all power lost, the tug environmental control system stops functioning and the crew compartment immediately begins to cool down. The lack of power to electronic equipment would deny this usual source of heat.

The limiting survival factor then is seen to be not life support but environmental control. If the crew were in pressure suits, with backpack units, there would be no immediate problem. If pressure suits and backpack units were not available, the crewmen would have to depend on the thermal insulative capability of available pressure garments.

Table 3-6 presents a rescue timeline sequence for rescue from a drifting tug in the near vicinity of the orbital station and with all electrical power out. The rescue vehicle is a tug docked to the orbital station. With a response time of 145 minutes, the interior ambient temperature of the crew compartment of the stranded tug would probably reach subfreezing levels. It follows that the stranded crew must have some form of environmental control capability such as pressure suits and backpack units, must have insulated pressure garments, or the crew compartment must be insulated to maintain a habitable ambient temperature in the crew compartment for a minimum of 3 hours, including a contingency factor.

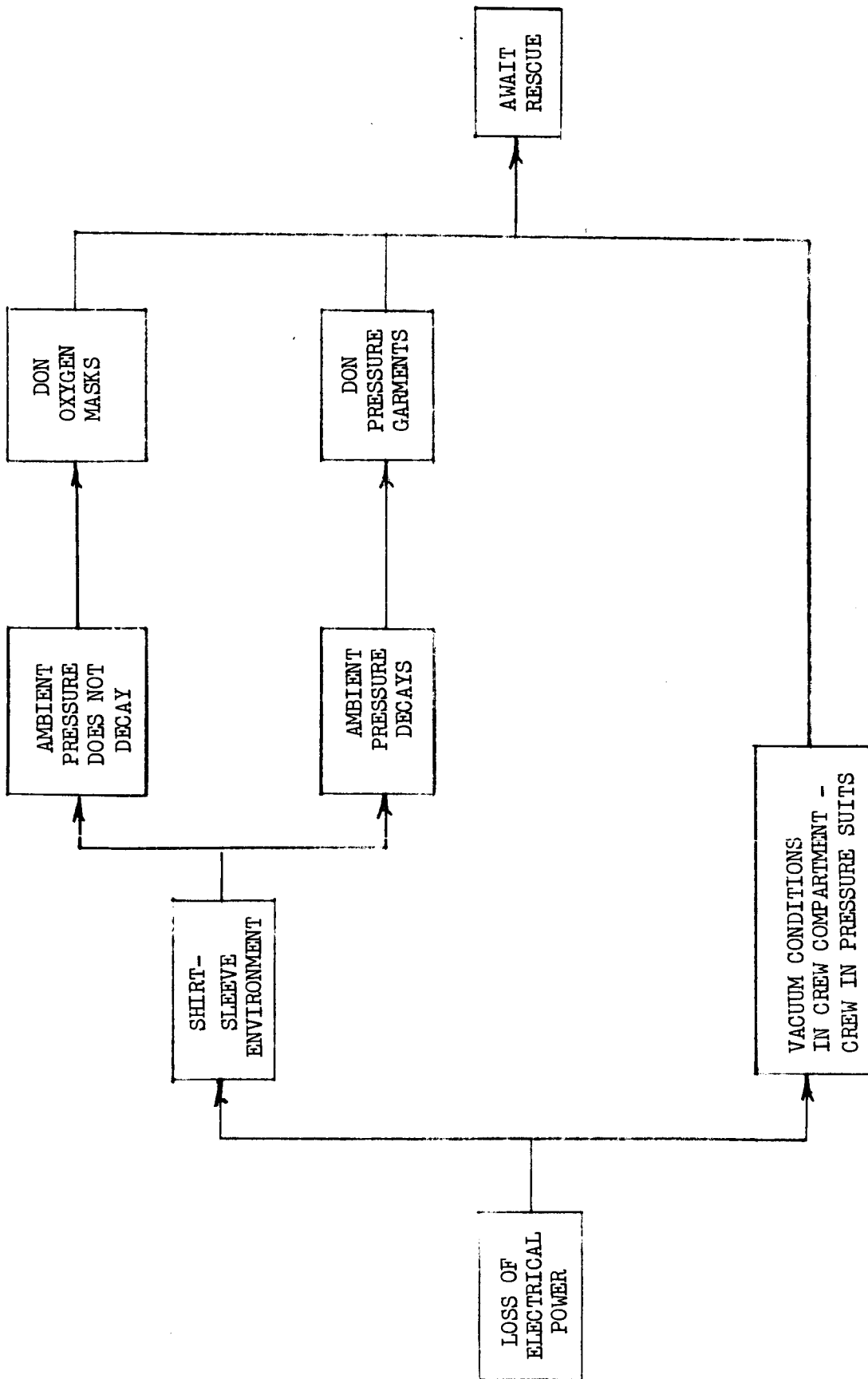

Fig. 3-2 Sequence of Events Following Loss of Tug Electrical Power and Life Support

Table 3-6

RESCUE TIMELINE SEQUENCE FOR A TUG DRIFTING IN LUNAR ORBIT
(time in minutes)

Event	Time Span	Accumulated Time	Remarks
Rescue Decision Made	-	-	Automatic decision based on non-receipt of voice communication from tug.
Activate Tug and Rescue Crew	120	120	
Separate from Station and Transfer to Stranded Tug	10	130	100 ft./sec. Δ velocity and 5 nm range to stranded tug.
Rendezvous and Dock	10	140	
Remove Crew	5	145	Rescue tug serves as temporary safe haven.

3.3.1.3 Critical Failure of an Orbital Tug

Crew and passenger survival in the event of a critical tug failure will depend on the location and nature of the damage. In this type of failure the tug sustains severe physical damage causing possible loss of structural integrity and deterioration or loss of a critical subsystem. Crew injury or jeopardy is probable. A critical situation could be caused by a collision during docking, or by a meteoroid strike, and could be accompanied by fire or explosion. Sudden and rapid depressurization could also occur as a result of shrapnel, explosive force or meteoroid damage.

Figure 3-3 presents an event sequence for an orbital tug critical failure. Contamination of the crew compartment ambient atmosphere could be counteracted by donning oxygen masks or emergency pressure garments. If the life support system remained functional, the crew could remove the masks as soon as the atmosphere was cleared. Proper design of the recirculation system, including the providing of suitable filters or precipitators, could provide this capability.

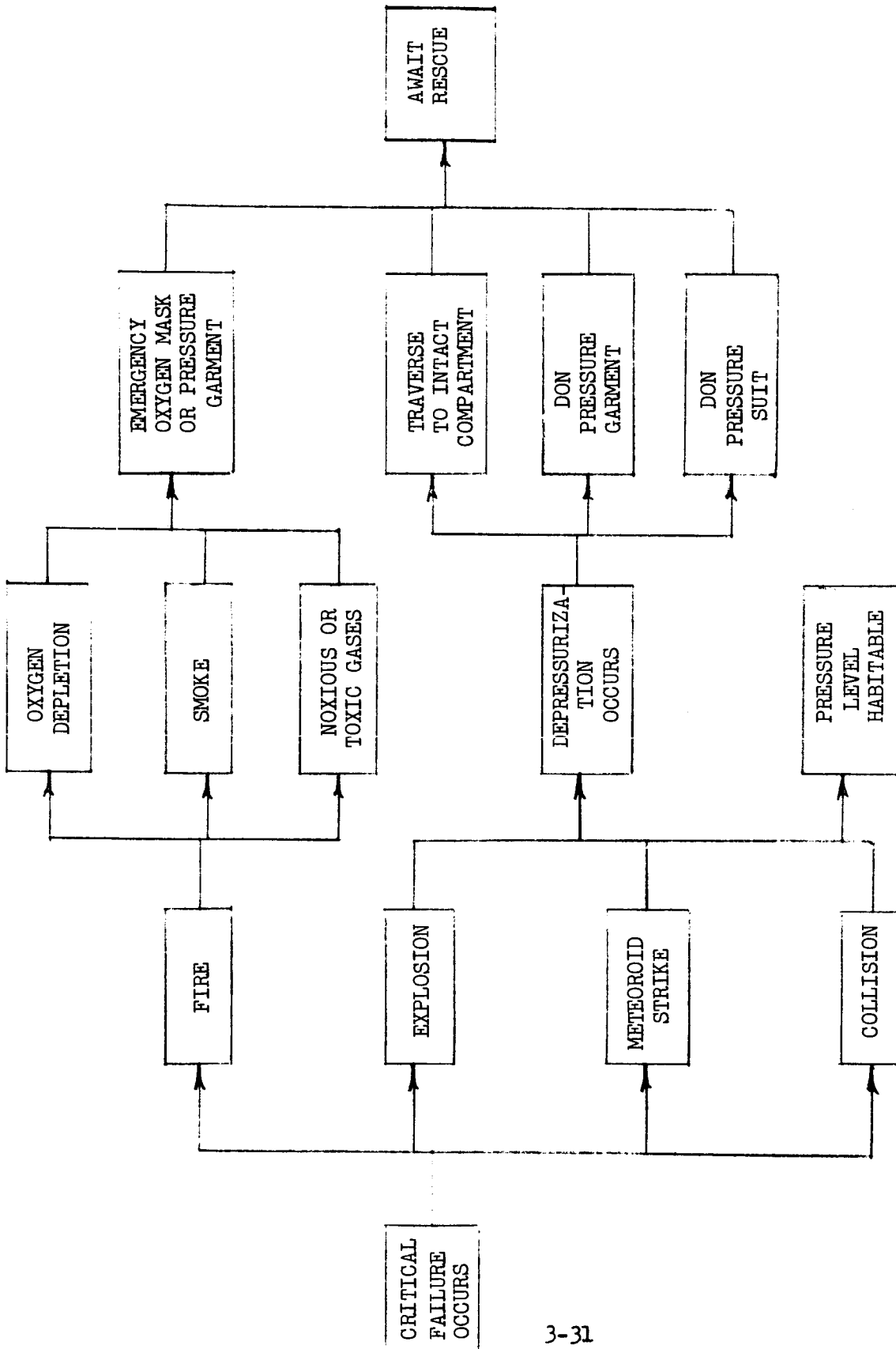

Fig. 3-3 Orbital Tug Sequence of Events Following Critical Failure

Crew compartment depressurization would require the immediate donning of pressure suits or emergency pressure garments. An umbilical connection into the tug life support system would provide extended life support and environmental control capability.

Design of the tug crew compartment as two separate and independent pressure cells would provide increased possibility for the survival of at least one compartment in a critical situation. Either cell must be capable of supporting the crew and any passengers for a minimum of 3 hours.

Either pressure suits with backpack units, or insulated emergency pressure garments, would be needed to counteract the probable loss of environmental control capability and the loss or deterioration of crew compartment atmosphere.

3.3.1.4 Logistics Cargo Transfer to and from the Orbiting Lunar Station

A critical failure in the tug during cargo transfer operations could result in the tug's functional capability being compromised by the on-board presence of cargo as tug payload. Some examples of the effect on tug capability by this type of situation are as follows:

- a. A low thrust-to-weight ratio resulting in significant decreases in ΔV capability for rescue or escape purposes
- b. Maneuvering impaired due to loose cargo
- c. Restrictions in maneuvering due to handling limits incident to the particular type of cargo
- d. Low ΔV capability due to off-loading the tug to preserve suitable thrust-to-weight ratios for heavy cargo maneuvering purposes.

It follows that tug and cargo container design must be amendable to rapid and selective jettisoning or separation from the tug. The separation systems must be self-contained, and operable regardless of the tug failure mode. Separation springs could be installed in the cargo attachment mechanisms to provide a separation ΔV (with respect to the tug) of 5 to 10 ft./sec.

Following the end of the emergency period, it would be desirable to recover any jettisoned cargo. Cargo module design should therefore include corner reflectors or repeaters for laser or RF radar detection.

3.3.1.5 Orbiting Lunar Station Maintenance and Repair

The tug will probably be used for the maintenance, repair, and assembly of the orbiting lunar station. This task involves tug operations close to and in direct contact with the orbital station. In a typical mission of this type, the tug would carry a payload consisting of a bulky and/or heavy replacement part such as a solar array or antenna. The tug would move a short distance away from the station, perhaps a hundred feet, and maneuver around the station until it is opposite the repair point. The tug then moves into position for removal of the hardware to be replaced and maintains this position until the hardware exchange is completed.

Because of the possibility of collision with the station or structural damage to the tug while handling large, bulky, heavy parts and possible loss of integrity of the tug pressurized compartment, it is recommended that the tug crew wear pressure suits at all times during maintenance and repair operations. The helmets should be close at hand and ready to be donned by the crewmen.

3.3.1.6 Tug/Station Collision

A collision between the tug and the orbiting lunar station could disable the tug and cause major damage to the station. Depressurization of both spacecraft is probable. Even though the tug communication system might be inoperative as a result of the collision, the station damage control and data management system would detect either the collision itself or its damage effects on the station. Inability to contact the tug would provide a positive indication of need for rescue.

As a result of the collision, the tug could slowly drift away from the station, could be slowly tumbling, and the crew compartment could depressurize due to structural damage. The depressurization will undoubtedly accentuate the tumbling. There is also a high probability that one or more on-board crewmen may be injured.

The 145 minute response time for a docked tug to be activated, separated from the station, and to complete rendezvous and docking is consistent with the probable tug crew survival time provided:

- a. The tug crew was in pressure suits at the time of the collision and depressurization
- b. Pressure suit helmets were readily accessible and could be donned in a few minutes
- c. The backpack design is such that activation and functional operation can be achieved in a few seconds
- d. The cabin atmosphere was of such a composition and pressure that denitrogenization is not required

The alternative to the above outlined requirements is to provide the tug crewmen with a pressure garment that can be placed into position around the crewmen and sealed in a matter of seconds. This garment must either provide a survival time of at least 3 hours, including a contingency factor, or there must be an additional provision for the crewmen to don a pressure suit and activate a backpack unit.

The rescue operation for the disabled tug would be performed by either one of the docked tugs at the station, or by a tug from a surface sortie site or the lunar surface base, or by a rescue vehicle from the Earth vicinity. In the latter case the required minimum survival time of 14 days is probably inconsistent with pressure suit and backpack survival time or with the probability of survival of injured tug crewmen. The recommended rescue procedure is to: (1) use station crewmen and docked tug, or (2) use surface site or lunar surface base tug and crew.

3.3.1.7 Tug Critical Subsystem Failure

The failure of a tug critical subsystem while the tug is operating near the orbiting lunar station could result in a collision between the tug and the station or appendage-type hardware such as solar arrays or antennas. The loss of a subsystem such as communications, life-support, data management, and even

power would not result in a critical situation as long as attitude control and some means of velocity vector control were still available. It is therefore strongly recommended that the tug design provide for manual control, through mechanical linkages or cables, of an emergency attitude control and propulsion subsystem. The propulsion subsystem could be either liquid or solid propellant and would be used to prevent collision or undesired contact with the station or other spacecraft such as PTV, propellant depot, other tugs, or scientific satellite. The attitude control subsystem should be capable of low-thrust velocity vector control and tumble arrest, as well as tug attitude control.

Rescue of personnel aboard tug damaged as a result of a collision or meteoroid strike poses several critical problems. If the crewmen are injured or ill, these problems are further compounded.

It would be particularly difficult to effect entry into a damaged tug if there were no means for positioning and mechanically linking the damaged tug and rescue tug. The simplest method of attachment would be by means of a standard docking mechanism. If the available docking mechanism is not usable an emergency linkage or attachment mechanism will have to be used. Attachment points could be designated and positioning marked on the exterior surface of tugs (as well as other manned spacecraft and the orbital station) to permit attachment of a grappling hook or other attachment device. Manipulator arms with hooks or heavy duty pincer type claws could be used to tie into these emergency attachment points or even to break through the tug skin to grasp a primary structural member.

Once the two vehicles were firmly and positively linked, the rescue crew would egress, attach an airlock if the crew compartment retained sufficient atmosphere, and enter the vehicle. If tug instrumentation was not available to determine the presence and composition of a cabin atmosphere, portable instruments could be used with the sensing end inserted through small holes drilled into the cabin interior. If there were no cabin atmosphere the cabin

wall could be cut open and direct entry made. If cabin atmospheric pressure was high enough to sustain life (approximately 2 psi) a means of communicating to the disabled tug crewmen would be needed through the crew compartment walls. If the disabled crewmen were not in pressure suits or emergency pressure garments, a portable airlock would be required to effect entry.

The possible necessity to effect forced entry into the tug or other manned vehicle crew compartment or quarters must be taken into account in the design phase. In addition, rescue crewmen should be familiar with the general structural characteristics of all manned spacecraft.

3.3.2 Lunar Tug Orbital Operation (Refer to Hazard Studies 12, 14)

The tug lunar orbital operations away from the near vicinity of the orbital station will probably consist of three primary activity areas:

- a. Placement, maintenance, repair, and return of scientific or communications satellite
- b. Logistics and crew rotation flights to and from the lunar surface base
- c. Scientific sorties flights to the lunar surface of approximately 28-day duration

Preliminary data on lunar operations sequencing indicate that the first surface sortie flight will take place about 6 months after station activation, and the lunar surface base will become operational about 3 years after activation of the orbital station.

3.3.2.1 Scientific Satellite Placement

The tug vehicle may be used to transfer scientific satellites from the PTV or the station to various orbital positions within the lunar sphere of influence, make return maintenance and repair flights, and in some cases return the satellite to the station. The general operational sequence for a satellite placement flight to a high lunar orbit is presented in Table 3-7.

Table 3-7

SEQUENCE OF EVENTS FOR PLACEMENT OF SCIENTIFIC
SATELLITE INTO HIGH ALTITUDE LUNAR ORBIT

Event	Time Span (min.)	Accum. Time (min.)	ΔV Required (ft/sec)	Remarks
Pick Up Payload	-	-	-	Payload is one or more scientific satellites
Transfer to Desired Orbital Position Relative to Station	60	60	100	
Transfer to Elliptical Orbit	5	65	1950	30-hour period orbit
Coast to Apogee	900	965	-	
Circularize at Apogee Altitude	5	970	580	1,380 ft./sec. Circular velocity required
Coast to Desired Orbital Position	60	1030	-	Time span required depends on desired orbital position
Separate Satellite	5	1035	-	
Coast to Desired Orbital Position	5	1040	-	
Inject into 30-Hour Period Elliptical Orbit with 60 nm Perigee	5	1045	580	
Coast to Perigee	900	1995	-	
Circularize in Parking Orbit	5	2000	1950	
Phase with Station	60	2060	-	
Rendezvous & Dock with Station	30	2090	150	
Total	-	2090 min. (35 hr.)	5310	Well within normal tug capability

For this type of mission, approximately 5310 feet/second of impulse and 35 hours is required. In general, these requirements leave ample margins for crew survival, as far as life support is concerned, regardless of when an emergency occurs during the mission and assuming the life support subsystem remains functional. The trajectory is such that, if planned and executed properly, there would be no danger of surface impact, collision with another spacecraft, or insertion into a lunar escape trajectory.

Providing the crewmen with planned vehicle trajectory and attitude data along with the capability to monitor vehicle maneuver and propulsion performance would enable them to cut off their propulsion system prior to achieving an undesired trajectory condition. An emergency backup cutoff control system should be provided that positively shuts off the primary propellant flow to the propulsion system.

Table 3-8 consists of a tabulation of rescue situations that could occur during performance of this type of mission, along with corresponding survival and response times. Note that a successful rescue can be accomplished, with ample survival time margins, in all cases except those involving direct or indirect failure of the tug life support system or power.

A failure in the life support system (a power failure would have the same effect) would not require an immediate switchover to pressure suits or garments and backpack units. A breathable atmosphere would exist in the crew compartment at the time of failure and for perhaps as long as an hour or more. The exact span of time cannot be predicted, but an hour seems a reasonable estimate, assuming that the failure produced no toxic gases or smoke. If electrical power was available, and cabin heaters still functional, it is conceivable that several hours could pass before activation of backpack units would be required. If cabin pressure remained above about 2.5 psi the crew could switch to oxygen masks and survive indefinitely as far as breathing is concerned. Under these conditions, an insulating thermal garment could passively utilize body heat to maintain a liveable thermal balance. The crew then should be able to survive at least 36 hours and perhaps 48 hours even without water and food.

Table 3-8
 POSSIBLE RESCUE SITUATIONS FOR HIGH ALTITUDE
 SCIENTIFIC SATELLITE PLACEMENT MISSIONS

Rescue Situation	Survival Time	Response Time					Successful Rescue Probable?	Remarks
		Communica- tions Delay (Min)	Tug & Crew Activation (Min)	Flight Time (Min)	Crew Removal (Min)	Total Response Time (Hrs)		
Propulsion Failure	7 days	60	120	1035	1055	38	Yes	Dock with disabled tug and return it to station
Communications Failure	7 days	Function of Report Time Span 30 min	120	1035	1055	37	Yes	Same as above
Navigation Subsystem Failure	7 days	60	120	1035	1055	38	Yes	Same as above
Guidance/Attitude Control Failure	7 days	60	120	1035	1055	38	Yes	Same as above
Power Failure	Emergency Backpacks, 2 per man, 24 hours	Function of Report Time Span 30 min	120	1035	30	20	Yes, if backpack capability is 20 hours or cabin pressure maintained above safe level	Transfer crewmen from disabled to rescue tug
Life Support Failure	Same as above	60	120	1035	30	20	Same as above	Same as above
Critical Failure	Same as above	Function of Report Time Span 30 min	120	1035	30	20	Yes, if backpack capability is 20 hours	Survival is function of vehicle damage and severity of any injuries

If cabin pressure decays below a safe minimum, pressure garments and backpacks would be required. The available pressure garments and backpacks must permit a minimum of 20 hours (Table 3-8) survival time to make rescue feasible. Two 6,000 Btu backpacks per man would provide 24 hours survival, if the crew were resting while awaiting rescue (500 Btu/hour).

A critical failure, such as an internal explosion or meteoroid strike, would probably structurally damage the crew compartment and result in rapid depressurization. In this type of situation, survival will depend on the availability of pressure suits or garments and backpack units, and the crew's ability under emergency conditions to don and activate them within an acceptable time.

The maintenance of a safe crew compartment ambient pressure level is critical to crew survival. An emergency method of plugging or sealing holes, rips, or jagged tears in the crew compartment walls would permit the crew to use oxygen masks and thermal garments with a potential survival time of at least 48 hours. Without compartment ambient pressure, the crew must resort to some type of closed cycle pressure suit or emergency garment with performance capability comparable to that of pressure suits and backpack units.

3.3.2.2 Lunar Lander Tug Surface Sortie Flights

Scientific sortie flights by a lunar lander tug are assumed to start six months after activation of the orbiting lunar station. The nominal tug crew will typically consist of 4 men with a 28-day nominal life support capability, plus a 14-day contingency. These sortie flights will be planned for descent and ascent in the orbit plane of the orbiting station. Landing sites on the Earth side of the Moon will always have potential communication capability with the Earth. Communication with the orbiting station will be possible during the landing phase, depending on phasing conditions. Proper operational sequencing would also permit the station to be within communications range and line of sight during the ascent phase.

A critical subsystem failure prior to powered descent initiation (PDI) would permit a mission abort and, at most, would leave the lander tug in a slightly elliptical orbit with apolune at the orbital station altitude and perilune at PDI altitude. (For Apollo missions, these altitudes were 60 nm and 8 nm, respectively.) Rescue from the station would require only 330 minutes to accomplish versus a minimum survival time of 12 hours for the worst-case situation of either a total power or life support failure. Rescue time of 330 minutes

is based on the following sequence:

60 min.	Communications Delay (Assuming Relay satellite)
120 min.	Tug and Crew Activation
120 min.	Flight Time
<u>30 min.</u>	Crew Removal
330 min.	Total Response Time

The possibility of rescue after initiation of PDI depends on the nature of the subsystem failure and its side effects. A propulsion failure after initiation of PDI will result in impact unless a second stage or auxiliary propulsion system is available. To increase the chances and duration of survival following a crash landing, the crew should be in pressurized suits with freshly charged backpacks during powered descent. This would provide life support for 12 hours, which is sufficient time for a rescue tug to come from the orbiting lunar station. If the rescue tug were manned and activated during the powered descent phase of the lunar landing, it could get down in 2 hours (one orbital period), because the orbiting lunar station would be in line of sight and coincident with the lunar lander. Because essentially no plane change would be required, the rescue tug (with a total ΔV of 15,000 ft/sec) could immediately return to the orbiting lunar station with the distressed crewmen for medical treatment. Loss of the guidance system can be counteracted by resorting to full manual control of the vehicle propulsion and attitude control subsystem. With this capability, a surface landing is possible; however, the recommended procedure is to switch to an ascent mode and return to an altitude above 8 nm and inject with an orbital velocity sufficient to provide a perigee minimum of 8 nm. An orbital rescue operation can then be accomplished.

Lander tug ascent to orbit from surface sortie flights could provide situations similar to those listed in Table 3-9 for descent flights.

3.3.2.3 Lunar Surface Base Logistics Flights

Lunar surface base (LSB) logistics flights will be faced with the same type potential rescue situations as are encountered on the lander tug surface

Table 3-9
LUNAR LANDER TUG RESCUE SITUATIONS - POWERED DESCENT INITIATION TO TOUCHDOWN

Rescue Situation	Survival Time	Response Time				Successful Rescue Possible?	Remarks
		Communication Delay (min.)	Tug & Crew Activation (min.)	Flight Time (min.)	Crew Removal (min.)		
Primary Propulsion or Attitude Control Failure	Max. of 12 min.	Max. of 60	120	120	30	330	No 2nd Stage or back-up propulsion needed to brake fall and decrease any horizontal velocity
Guidance/Navigation Failure	Max. of 12 min.	Max. of 60	120	120	30	330	See Remarks Manually controlled landing or ascent to orbit possible
Life Support	Backpack	-	-	-	-	-	See Remarks Abort and return to station - no rescue required
Power Failure	Backpack	Report time span or 60	120	120	30	330	See Remarks Manually controlled landing or ascent to orbit possible
Communication or Other Sub-System Failure	42 Days	Report time span or 60	120	120	30	330	See Remarks Abort and return to station - no rescue required

sortie flights previously discussed. One notable exception is in the area of communication. The LSB site will probably be permanent and manned at all times after activation. Logistics tugs will be within line of sight of the LSB communication and tracking capabilities during the powered phases of descent and ascent. In case abort was necessary and possible during either ascent or descent, the LSB could support the aborting tug with tracking information and navigation data. In addition, the LSB could also support a manual landing at the LSB tug landing site.

3.3.3 Escape/Rescue Guidelines for Lunar Tug Operations

The following escape/rescue guidelines are proposed for operations with a space tug in lunar orbit, landing, and surface operations.

1. A minimum of two space tugs are needed to support the orbiting lunar station. One tug should be fully serviced, with a full load of propellants, life support and other expendables, and emergency rescue equipment, and then function as a dedicated escape/rescue vehicle. The second tug would be used for near vicinity orbital operations. A third tug is required at the start of surface operations.
2. Properly positioned omni antennas should be used for short-range space tug voice and data communications to insure no loss of signal due to the aspect angle or attitude relative to the orbiting lunar station, Prime Transport Vehicle, propellant depot, surface site, or Earth vicinity. This capability is particularly important to maintain continuous communications with a tumbling vehicle.
3. Any spacecraft in the lunar vicinity should have external attach points by which a rescue vehicle such as a tug could attach rigid couplings and maneuver or provide thrust vector control as required. Rescue tug crewmen will probably require visual, direct line-of-sight capability or remote optical sensors and visual displays to maneuver relative to the stranded vehicle and complete the hookup.
4. Passive thermal control garments are needed for use by the crew following either an electrical power or environmental control subsystem (ECS)

- failure. There would be ample time to don such a garment, because cabin cool-down would be relatively slow. A less desirable alternative is to insulate the crew compartment walls to maintain a livable temperature for a minimum of 3 hours after an ECS or power failure.
5. Sudden depressurization of a crew compartment requires rapid response emergency techniques and/or equipment to prevent subjecting the crew to dangerously low ambient pressure.
 - a. The crew should be in pressure suits during those operations in which the tug or spacecraft is maneuvering close to other spacecraft, the orbiting lunar station, or propellant depot.
 - b. If helmets cannot be worn because of visibility requirements, the helmets should be so designed, and so located relative to the crewmen, that they could be donned at least to the extent that suit ambient pressure integrity is assured within 5 seconds after occurrence of the emergency.
 - c. Visual and aural warning signals are needed to inform the crew of a critical broaching of cabin ambient pressure integrity.
 - d. Emergency pressure garments should be available that could be donned even over a pressure suit, and that would attain pressure integrity within about 5 seconds.
 6. An emergency attitude control/translation subsystem, manually controlled, is needed in the event a space tug subsystem failure occurred, leaving the tug on a collision course with another spacecraft. The thruster subsystem might need a throttling capability, depending on thrust-to-weight variations (and consequent acceleration variations) due to payload and/or propellant weight variations.
 7. A routine space tug crew report-in sequence is needed as a backup alarm system. A recommended report-in sequence is a minimum of one contact every 30 minutes, with an automatic rescue alarm if communications contact is not made within five minutes after the scheduled contact time. This time span and automatic alarm interval could be adjusted as a function of the particular tug, spacecraft, or crew operation mode.

8. The space tug ambient atmospheric recirculation and purification loop should include the capability to remove noxious or toxic contaminants that may be present due to failure, fire, or a critical situation.
9. The space tug and other manned spacecraft should be designed with two or more separate and independent pressure compartments. Each compartment should have a dedicated and separate emergency life support and ECS subsystem that will provide a survivable atmosphere and ambient condition for a minimum of 3 hours. This approach would increase the possibility for the functional survival of at least one compartment.
10. Cargo modules to be carried by the space tug should be so designed that they can be selectively jettisoned with a ΔV , with respect to the tug, of at least 10 ft/sec. Modules that could be jettisoned should be equipped with passive and active acquisition, rendezvous, and tracking devices to aid in their search and recovery following the end of the emergency period.
11. Tug crew compartment ambient atmosphere should be maintained at 3.5 psi and of a pure oxygen composition to prevent possible crew disablement in the event of cabin depressurization and the need to switch rapidly to pressure suits, backpack units, or emergency pressure garments.
12. Space tug design should include provisions for manual control, through mechanical linkages or cables, or an emergency attitude control and propulsion subsystem.
13. Some means is needed to rigidly link a rescue vehicle to a distressed vehicle to provide a stable platform from which a forced entry could be made into a distressed vehicle. Attachment points should be clearly marked, and potential rescue crews instructed in their location and methods for attaching link-up devices.
14. A portable airlock is needed that can be handled by two EVA crewmen, and that is large enough to accommodate an injured crewman and at least one other crewman.

15. Portable instrumentation is needed, together with some technique for determining the pressure and composition of the stranded vehicle's crew compartment ambient atmosphere. If there were no compartment pressure, access could be made by direct cutting through the spacecraft wall.
16. On all spacecraft, areas acceptable for entry by either direct means or by means of a portable airlock should be clearly identified and marked. Structural design must provide for sufficient space between primary load-carrying structural members so that entry could be made using simple skin-cutting tools rather than torches or heavy-duty cutters. It is assumed that insulation and micrometeoroid barriers can be removed quickly by simple hand tools. One possibility is to provide pyrotechnic installations that would cut the skin between structural members by means of an applied electric current. The cut-through area should be sized to be consistent with the effective area of a portable airlock, and consistent with the requirements for handling injured crewmen in emergency pressure garments.
17. The space tug crewmen should be able to monitor and evaluate their ephemeris in order to detect a potential or actual undesirable trajectory condition.
18. Pressure suits, backpacks, or emergency pressure garments must provide a minimum of 20 hours of survival time. Under emergency conditions, a crewman could be provided with a potential survival capability of up to 48 hours by a combination of a passive thermal garment, emergency pressure garment, and oxygen sufficient to maintain at least 3.5 psi ambient pressure and a breathable atmosphere within the pressure garment.
19. Techniques and materials are needed to quickly find and seal holes, rips, or jagged tears in the crew compartment pressure cell walls.
20. Emergency manual control of the tug propulsion and attitude control subsystem would permit a manually controlled emergency landing in the event of a guidance system failure after powered descent initiation.

21. The rescue tug in lunar orbit must be provided with navigational updates after making plane changes or other orbital maneuvers that introduces significant errors into the tug guidance system.
22. In order for the rescue tug to operate autonomously in the lunar area a correct lunar gravitational model must be determined and the exact location of all manned surface sites must be known in terms of a coordinate grid system that is compatible with the tug navigational computer algorithm.

3.4 ORBITAL PROPELLANT DEPOT OPERATIONS (Refer to Hazard Study 13)

A lunar orbital propellant depot may be used to supply cryogenic propellants and other expendable liquids and gases for the tug propulsion, intelligence, and crew modules. Thus, the propellant depot would serve no other purpose than to supply and store consumables.

Although a propellant depot configuration has not been defined, it is expected that it would include the following types of subsystems if it were located remote from, and unattached to, the orbital station:

- a. Tanks, pumps, plumbing, and transfer mechanisms for liquids and gases
- b. Electrical power source
- c. Data management system - probably computer-controlled (including instrumentation and control)
- d. Communication system for transmitting logistics and status information to the orbital station, Earth vicinity, and tugs, and for remotely controlling the fuel depot from the orbital station
- e. Guidance system, including altitude and range control between the depot and the station
- f. Active and/or passive rendezvous and docking devices and sensors
- g. Stationkeeping reaction system that probably would serve double duty for attitude control as well as stationkeeping
- h. Life support (may include a shirtsleeve environment control compartment)

If the propellant depot were attached to the orbital station, or were an integral part, most of the above configuration items would not be necessary, and could be eliminated entirely, or the required capability could be supplied by the station.

The fuel depot could be located in three possible general areas relative to the orbital station:

- a. In close proximity
- b. Approximately 5 nm distant and in same orbital plane and at same altitude
- c. On different orbit plane and at hisher altitude

By locating the propellant depot in a suitable different orbit from that of the station, a possible collision between the orbital station and any debris originating at the depot could be minimized. There is a tradeoff between this minimization and the added maneuvering costs required for a tug to traverse between the station and the depot. This tradeoff is beyond the scope of this study.

Three types of operations will result in one or more crews being at the depot:

- a. Routine and emergency vehicle servicing
- b. Routine and emergency propellant depot maintenance and repair
- c. Replenishment of depot supplies by transferring consumables from the PTV to the depot

3.4.1 Vehicle Servicing at the Propellant Depot

Vehicle propellant servicing requires that the manned vehicle rendezvous and dock with the depot, that liquid and gas transfer lines be connected, the transfer of consumables into the tug, and disconnecting and separating the tug from the depot. Depending on depot design and operations requirements, it may be necessary for one or more tug crewmen to go on EVA in order to service the vehicle, although this should be avoided if possible.

A tug vehicle failure while in transit between the orbital station or PTV and the depot should be handled in a manner similar to that discussed under Section 3.3.1, Tug Operation Near Vicinity of Orbital Station, and will not be discussed here. A disabling critical failure occurring while docked to the propellant depot could be handled by a second tug - normally docked at the station - making an orbital transfer to the depot.

Communications should not be a problem, since both the depot and tug communications systems will be available. The rescue tug would simply dock with the stranded tug, separate it from the depot, return to the orbiting lunar station, and dock the stranded tug (and crew) to the station.

If the stranded tug could not undock from the depot, the rescue tug should be able to actuate an emergency mechanical undocking, or unlatching, mechanism that would uncouple the disabled tug from the depot docking port, remove the crew if necessary, then return to the station.

Crew survival following a critical propellant depot failure while the tug is docked to the depot and being serviced, will primarily depend on the tug's capability to disconnect fueling and servicing lines and to undock under emergency conditions. Control and power for this operation must be from the tug side of the interface. The use of pyrotechnic devices to cut lines, pull latching pins, or cut bolts might be appropriate and necessary, even if open-and-still-flowing lines remained on the depot side of the interface.

If the docked tug could not undock as a result of a critical failure, crew survival will depend on: (1) the tug life support subsystem functional status

and crew compartment ambient pressure integrity, or (2) their backpack residual. Crew survival would be unpredictable, of course, in the event of a depot fire or explosion.

The worst-case survival situation occurs if the crew is dependent on pressure suits and backpack units or emergency pressure garments for survival. The response time for rescue by a tug docked at the station is of primary concern. Table 3-10 presents a tabulation of the rescue tug sequence of events and time spans.

Table 3-10 PROPELLANT DEPOT CRITICAL FAILURE - TUG CANNOT UNDOCK

Sequence of Events	Time Span (Min.)	Accum Time (Min)	Remarks
Receive notification of Emergency	15	15	Notification may be failure to report at designated times
Tug & Crew Activation	120	135	
Separate and Transfer to Depot	10	145	100 ft/sec orbital transfer speed - Depot 5 miles range from station
Assess Situation & Dock with Stranded Tug	5	150	Dock with stranded tug crew module
Transfer Crewmen to to Rescue Tug	15	165	Rescue tug is temporary safe haven
Return to Station	-	-	-

A critical situation with one or more crewmen on EVA on the depot could result in a situation in which the docked tug would be forced to undock and separate from the depot leaving the EVA crewmen behind. A dangerous emergency on the

depot involving fire, smoke, or escaping high-pressure gases or cryogenics would probably preclude a rescue tug from docking, or even moving into a position in close proximity to the depot. In this type of circumstance, the EVA crewmen could be stranded and in extreme jeopardy unless some means of escape were provided. An astronaut maneuvering unit (AMU) located on the depot could provide a means of escape - not only to leave the depot, but also to return to the station, using nothing but the AMU. A cold gas, manually operated vehicle, with perhaps some emergency oxygen on board, could easily provide the 100 ft/sec of impulse velocity needed to return to the station or to provide an additional 1 to 2 hours of survival time away from the station. An emergency flashing light, homing beacon, and corner reflectors, would be needed on the AMU for locator purposes. A short-range voice communications system would also be essential.

Depending on the range between the propellant depot and the orbiting lunar station, an AMU located at the station could be used as a one-man rescue device. Table 3-11 presents the sequence of events and response time for a typical rescue mission using an AMU based at the station.

Table 3-11 SEQUENCE OF EVENTS FOR RESCUE OF CREWMEN AT A PROPELLANT DEPOT BY AMU FROM THE ORBITING STATION

Sequence of Events	Time Span (Min)	Accum Time (Min)	Remarks
Prebreathe-Denitrogenization	60	60	Pre-breath oxygen, with exercise
Egress/Ingress thru Airlock	48	108	Include donning pressure suit
Activation	45	-	Activation accomplished in parallel with denitrogenization
Transfer, Station-to-Depot-to-Station & Pick up Stranded Crew	10	118	No contingency for search or for handling injured men

The denitrogenization process could be performed using exercise to reduce the time span. Note that AMU activation could be performed by another crewman in parallel with the denitrogenization process, and would therefore not add to the accumulative time span.

If the depot were located as much as 5 nm from the station, the AMU might require a rendezvous sensor package including a range sensor.

The rescue of a crewman by another crewman using an AMU has been covered in Section 3.2.3, EVA Activities, and will not be further discussed here.

3.4.2 Replenishment of Propellant Depot Supplies

Replenishment of propellant depot supplies would probably involve the transfer of tanks or containers of cryogenics and other liquids or gases. The method of attachment of these containers to the tug must provide for rapid and positive uncoupling. This rapid uncoupling need could result from either a critical tug failure, or because of a need for a rescue mission.

3.4.3 Escape/Rescue Guidelines for Propellant Depot Operations

The following escape/rescue guidelines are proposed for operations at a propellant depot in lunar orbit.

1. The propellant depot must include emergency locator devices such as flashing lights, running lights, RF or optical beacons, corner reflectors, and active transponder.
2. An escape device such as AMU is needed for emergency use by an EVA crewman under critical emergency conditions at an orbiting propellant depot. A cold gas propulsion and attitude control reaction system with mechanical linkage control would permit virtually instantaneous actuation of the AMU followed by separation from the depot and translation to a safe range. After a safe position was reached, the escaping crewman could activate more complex and slower reacting electronic guidance, navigation, power, and communications hardware. The escape device would also need locator devices such as flashing lights, RF, or optical beacons, and active transponder.

3. An emergency despin system (3-axis) is needed to counteract tumbling torques or rates and reduce angular rates of a propellant depot to safe levels conducive to completion of docking and undocking maneuvers.
4. An emergency kit should be available on the propellant depot, with equipment items available such as
 - a. First aid supplies
 - b. Emergency pressure garments
 - c. Oxygen masks (for use in the emergency compartment or with pressure garments)
 - d. Portable lights
 - e. Flares - perhaps similar to photographic flashcubes, only larger in size and power
 - f. Passive thermal garments
5. Propellant depot docking mechanisms should be designed so that a docked vehicle could be uncoupled by actuating mechanical releases or pin pullers. It would be acceptable if the emergency uncoupling system caused disengagement with part of the depot docking mechanism remained locked to the tug mechanism.
6. An emergency decoupling system is needed on the propellant depot to sever servicing lines connected to the tug by pyrotechnic-actuated mechanisms. This system should be powered and controlled from either the tug or depot side of the interface.

Section 4

LUNAR SURFACE OPERATIONS

The lunar surface mission will involve the conduct of experiments and the gathering of data relating to both lunar phenomena and to phenomena external to the Moon (such as stellar and solar astronomical observation). These experiments may be located at any latitude, range over most Earthside longitudes and perhaps some farside locations. Their performance may require traverses, temporary experiment bases, and permanent surface bases. Considerable EVA activity may be required. The surface operations divide into lander tug operations to establish a temporary base and a permanent lunar surface base. The latter will be characterized by a fixed location on the Earth side of the Moon; immobile installation; crew compartments that may be elevated, surface mounted, or buried; substantial resources; scheduled resupply and crew rotation flights; and traverse operations that are backed up with several types of mobility vehicles. The temporary surface bases will have fixed locations including farside sites, elevated crew compartments, moderate resources, a scheduled lift-off, return to lunar orbit, and traverse operations with a limited number of mobility vehicles.

In this section the crew and equipment deployment and capability are described for the three types of lunar surface operation;

Permanent Lunar Surface Base Operations

Lander Tug Local Operations

Lunar Surface Traverse Operations

4.1 PERMANENT LUNAR SURFACE BASE OPERATIONS

4.1.1 Base Configuration

The lunar surface base will include living quarters for the base personnel, laboratories, science equipment, mobility vehicles for lunar traverses, electrical power generators, landing sites for lunar lander tugs, communica-

tions and equipments needed to support the base operations and possibly a propellant depot. The living quarters and laboratory may be elevated (on top of the propulsion module), surface mounted, or buried to obtain sheltering from the lunar environment including solar flare radiation. These configurations have an effect not only on the types of hazards which may arise, but also on the ingress and egress requirements of escape and rescue. Typical base hardware elements are shown in Figure 4-1. In this figure the base proper is elevated, sitting on top of a lunar lander propulsion module. This configuration places severe technical requirements upon the escape and rescue mission. The removal or escape of an incapacitated crew could involve the use of an elevator. Placing the base facilities on the surface relieves the dependency of escape or rescue on elevators and/or ladders, and may offer the opportunity of docking cabin rovers directly with the base. Buried bases may require elevators or ladders, but these may be inside the base in a shirtsleeves environment.

An additional factor in escape and rescue is the type of ambient atmosphere and pressure of the surface base. Denitrogenization is required of the crew in a transfer from an oxygen-nitrogen atmosphere to the space suit environment. The time needed to denitrogenize is three or more hours depending upon the techniques used, and this amount of time could influence the escape and/or rescue mission.

The separation between the lunar surface base and the normal tug landing site could be about 1-1/4 nm. This requirement limits the possibility of damage to the surface base because of tug explosion and lunar soil ejecta stirred up by the tug engines, but at the same time the separation influences escape and rescue timelines.

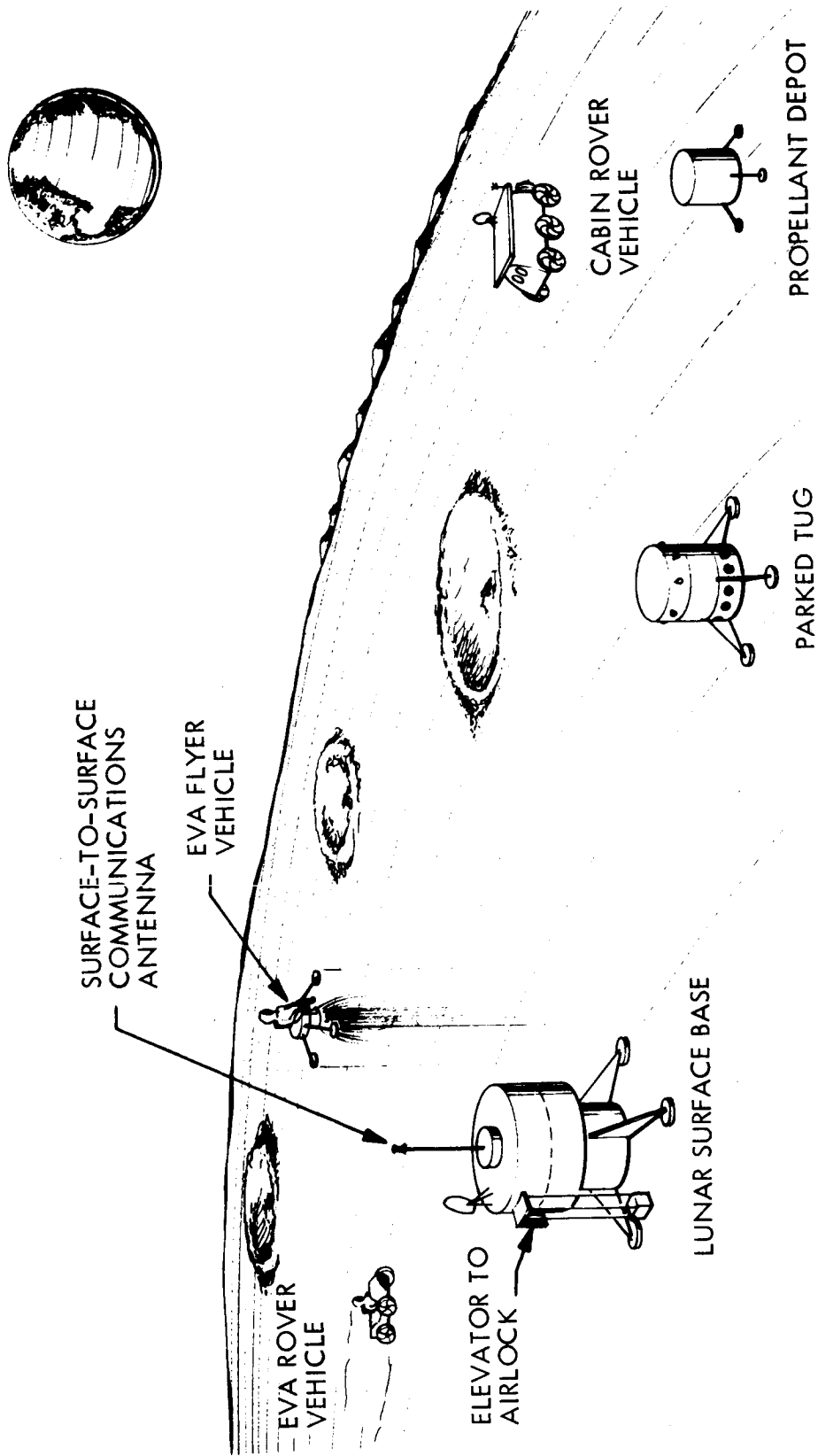

Fig. 4-1 Lunar Surface Base Elements

4.1.2 Operational Phases

The operational phases of the lunar surface base consist of initial manning and activation, routine operations, and deactivation.

As presently conceived, the base proper is landed unmanned. Manning and activating the base could require that the initial crew live temporarily in a lunar lander tug, and perform a number of construction tasks. For example, the base may need leveling, or a surface mounted base may need sandbagging. These types of outside activity raises the possibility of personnel injury.

The routine operations phase consists of housekeeping activities, outside exploration, and, periodically, logistics resupply and crew rotation.

The deactivation phase will probably consist mainly in preparing the base for storage, deactivating nuclear power plants (if any), removing salvageable equipment and instruments from the base, and loading the tugs.

4.1.3 Situations

The general situations during the base operations are listed in Table 4-1. There are significant differences between the initial and final phases and the routine phase of the base operations. During activation the base may not be habitable. Hence, a bad landing could leave the crew stranded on the lunar surface without a safe haven available. During deactivation, there may be no safe haven available should the tug fail during liftoff. In either case, the crew compartment of the tug may provide a safe haven for some time assuming that the integrity of the crew compartment has not been violated. The "worst" case for these situations is where the crew must resort to space suits and portable life support systems for survival. This class of emergency situations can be summarized as one in which the crew survival is limited by portable life support systems, and there is no primary vehicle available for leaving the surface of the Moon.

TABLE 4-1 GENERAL AND EMERGENCY SITUATIONS DURING SURFACE BASE OPERATIONS

	Initial Manning & Activation	Routine Operations	Deactivation of Base
Lunar Population	6	<ul style="list-style-type: none"> o 6 nominally o 8-12 during crew rotation 	6
Number of Tugs at Base	1	<ul style="list-style-type: none"> o 1 standby tug for safety o Add one during logistics resupply/crew rotation 	1
Normal Habitability at Base	No	Yes	No
Significant Hazards	<ul style="list-style-type: none"> o Lander tug damaged in landing (hard landing) o Rover vehicle damaged in unloading o Injury or equipment failure of personnel on outside activity o Men trapped or injured in base 	<ul style="list-style-type: none"> o Loss of communications o Injury or equipment failure of personnel on outside activity o Base crew incapacitated o Base unpressurized o Base atmosphere toxic o Base airlock inoperable o Logistics vehicle damaged in landing o Logistics vehicle damaged in liftoff o Logistics vehicle power failure 	<ul style="list-style-type: none"> o Injury or equipment failure of personnel on outside activity o Lander tug power failure prevents liftoff o Lander tug crashes at liftoff

In the initial manning and activation phase or during routine operations, the men may become trapped and/or injured inside the lunar surface base. This might occur as a result of an inoperable airlock or a critical failure.

The loss of communications at the base when no tug is available with alternate communications is a severe emergency. The escape/rescue plan must provide emergency communications to circumvent this possibility.

The routine operation of the base includes Internal Vehicle Activity (IVA) and External Vehicle Activity (EVA) situations after the base has been established. In the EVA situations, there will be only a fraction of the crew on EVA while the other members of the crew are inside the base (or in tugs during the other phases of base operations). Hence, a rescue can be mounted by the base crew, and the base offers a safe haven to which the EVA crew may be removed. If a portion of the crew is on EVA, it may be possible for the EVA crew to help those inside a disabled base. The base crew may be evacuated to the parked tug.

A particular IVA situation is where the majority of the crew in the lunar surface base are distressed to a point where they cannot help themselves. They require aid to correct the problems on-board the base, and to prevent further deterioration of their position. Subsequently, they may need evacuation, and help to perform this evacuation. The lunar lander tugs will nominally land or be parked up to approximately 1-1/4 nm from the lunar surface base. The distressed personnel probably cannot make this journey unaided. In addition, they need a crew to fly the tug from the surface to escape to orbit.

The typical situations in the vicinity of the base during routine operations are shown in Table 4-2. Lunar rover vehicles are at the base or on traverse. Extravehicular suits and mobility vehicles are available, including pressurized stretchers. There is one tug near the base for each 6 men at that base. In addition, there is a standby rescue tug in lunar orbit.

TABLE 4-2 TYPICAL SITUATIONS IN THE VICINITY OF A LUNAR SURFACE BASE DURING ROUTINE OPERATIONS

Case No.	Distribution of Personnel			Total Number of Personnel	Number of Tugs near Base*	Situation
	Base	on Traverse	Tug			
1	6	0	0	6	1	Rest Cycle
2	4	2	0	6	1	Normal Working Day
3	2	4	0	6	1	Special Projects Working Day
4	6	2	4	12	2	Unloading Supplies & Equipment
5	6	4	2	12	2	Transferring Personnel & Supplies
6	8	2	2	12	2	Initial Crew Rotation & Briefings
7	4	2	6	12	2	Final Crew Rotation
8	6	0	6	12	2	Preparation to Return to Orbit

* Assuming a standby tug parked near the base as a safety measure.

4.2 LANDER TUG LOCAL OPERATIONS

The lunar lander tug will make individual landings at various lunar sites. These sorties will permit the exploration of widely separated areas of the Moon, initially prior to establishment of the lunar surface base (LSB), but continuing on an on-going basis throughout the lunar program. A typical sortie will be characterized by the landing of a single tug having a total crew of four. The crew compartment may be elevated with the propulsion module below. The nominal mission duration will be up to 28 days. The site terrain may be somewhat rougher than that of the LSB, and landing aids will be minimal. Unlike the LSB, some sortie bases may be set up on the far side of the Moon.

Unless special landing sensors are used, the planned tug landings will be made at optimum sun elevation angles using techniques similar to that of Apollo. Ascent and descent will be within the orbital station orbit plane with only small plane changes required.

4.2.1 Operational Phase

Hard landings, subsystem failure, communications failure and severe injury to the crew members are situations that may arise during the landing and activation phase.

The routine operations following activation include housekeeping, crew personal activities, data acquisition and transmission, and ingress and egress operations. The tug will probably be pressurized with a two-gas atmosphere. Hazardous situations include communications, electric power, and life support failures, fire, meteoroid hits, and sickness and injury.

The deactivation and departure will be scheduled to reload the vehicle and perhaps to abandon certain equipment. The hazardous situations include the failure of the liftoff engine to fire, life support and environmental control system failure, lander subsystem failure, and severe injury during

equipment packaging and unloading.

The characteristics of the operational phase of the lander tug local operations and the significant hazards are shown in Table 4-3.

4.3 LUNAR SURFACE TRAVERSE OPERATIONS

The traverse operations take place in the vicinity of, or between, the permanent and temporary lunar surface bases. The traverse may be made by the crews on foot with and without a handcart, or in an EVA mobility vehicle, or in a pressurized cabin mobility vehicle. The objectives of these traverses include the following: To permit the crew to explore the lunar surface, perform experiments, set up instruments, transport cargo and/or crew, and construct base facilities.

4.3.1 Traverse Situations

Table 4-4 lists a number of proposed mobility vehicles. Range in the table is defined as the total distance that the vehicle can travel without refueling.

The EVA vehicles operate relatively close to a parked tug and/or a lunar base. The separation distance of base and vehicle should never be more than the distance that the vehicle can travel in one half the operating time of the EVA life support equipment.

The cabin rover vehicle may travel between two widely separated points on the Moon. The sortie base tug from which it originates may return to orbit after the rover vehicle reaches its point of no return, and the pick-up tug may not land until the rover vehicle nears its destination.

EVA traverses may lead to situations which require rescue. A critical factor is the condition of the pressure space suits and portable life support systems. A torn suit would require immediate remedy. For tears on the limbs, automatic, expanding, sealing diaphragms are a possibility. Effects of small punctures may be temporarily modified by increased pumping by the PLSS until a patch or pressure garment can be donned. In the event of damage to

Table 4-3
 ESCAPE AND RESCUE FACTORS OF LANDER TUG LOCAL OPERATIONS

RESCUE FACTOR	OPERATION	OPERATIONAL PHASE		
		Landing & Deployment	Routine Operations	Deactivation & Departure
Location Coordinates		Precise coordinates of location not yet established	Coordinates established	Coordinate Established
Lighting for Escape/Rescue		Daybreak Sun angle good	Day or night	Daybreak or night fall
Landing Aids		Not deployed	Deployed	Deployed
Angle between landing site and space station orbit plane		0 - 15 degrees	15 - 90 degrees	0 - 15 degrees
* Normal Survival Resources		28 days	28 - 0 days	0 days
Personnel Environment		Suited at Landing	Suited or Shirtsleeves	Suited at Takeoff
Significant Hazards		<ul style="list-style-type: none"> o Hard Landing o Subsystem Failure (Life Support System) o Communications Failure o Severe Injury to Personnel o Attitude Control 	<ul style="list-style-type: none"> o Subsystem Failure (Life Support System) o Communications Failure o Integrity of Crew Compartment Lost (Fire/Explosion/Meteorite) o Sickness/Injury to Personnel 	<ul style="list-style-type: none"> o Propulsion Failure (No takeoff) o Crash at Takeoff o Subsystem Failure (Life Support System) o Severe Injury to Personnel

* Does not include emergency/backup capability

Table 4-4
PROPOSED LUNAR SURFACE MOBILITY VEHICLES

Class of Vehicle	Name	Crew	Nominal Traverse Time	Typical Range (nm)	Typical Velocity (Knots)	Typical Dry Wt (Propellant Wt) (Lbs)	Typical Payload Inc. Crew (Lbs)
EVA	Apollo Rover Vehicle 4 Wheel	2	Backpack Duration	16	3	400	950
	Dual Mode Rover Vehicle 6 Wheel	2	Backpack Duration	16 Manned 540 Unmanned	4	700-1000	1000-1500
	Lunar Flyer Vehicle	1	Backpack Duration	10	180	300 (300)	400 + 1 man
	Up-rated Lunar Flyer	2	Backpack Duration	30	180	400 (600)	400-500 + 2 men
	Ground Effects Machine	1	Backpack Duration	22	14*	250-300 (300)	1000
Pres-surized Cabin	Small Cabin Rover	2	14 Days	270	5.4	5800†	700 + 2 men
	Large Cabin Rover	2	24 Days	400	5.4	8000 Δ	700 + 2 men

* Two stops every 2.7 nm

† Including 1000 lb. expendables

Δ Including 1700 lb. expendables

the space suit or PLSS unit, the capability of the individual to walk-back or drive-back is entirely or severely impaired.

4.4 LUNAR SURFACE ESCAPE/RESCUE ANALYSIS

In the following major sections, the escape/rescue situations, concepts, and guidelines are presented for each type of operation:

- a. Permanent Lunar Surface Base (Section 5)
- b. Lander Tug Local Operation (Section 6)
- c. Lunar Surface Traverse Operations (Section 7)

The general escape/rescue situations pertaining to the surface operations are described by the following factors:

1. Communications availability,
2. Availability of primary vehicle for escape,
3. Survivability of crew and availability of a safe haven,
4. Crew condition as a result of an emergency,
5. State of base as a result of an emergency (pressurization, atmosphere, airlock operability), and
6. Distribution of personnel at the time of an emergency (inside base, outside in lander tug).

There are many possible situations, not only because many emergencies can be postulated, but also because the equipment characteristics and deployment are parametric. Because of this proliferation of situations, an attempt is made to find "worst" or limiting cases which may have different escape/rescue requirements. The various classes of situations having common requirements suggest appropriate classes of escape/rescue plans. Hence, the setting up of situations is a prime motivation in the subsequent analysis of the escape/rescue requirements, and the evaluation of candidate plans.

Because the permanent surface base has the largest variety of escape/rescue situations and alternatives available, it is presented first, including a detailed analysis of the use of the lunar lander tug as an escape/rescue vehicle. The results of the permanent lunar surface base analysis are then

applied to the lunar lander tug temporary base operations in Section 6 taking note of the differences, such as crew size and stay time.

For the purposes of analysis, the traverse operations of both the permanent and temporary bases are discussed together in Section 7. This is because the traverse operations have many common escape and rescue requirements. The traverse operations are characterized by variable locations, mobile installations, limited resources, and variable scheduling.

Section 5

LUNAR SURFACE BASE ESCAPE/RESCUE ANALYSIS

This section analyzes operations at a lunar surface base and presents situations, concepts, operations, concept tradeoffs, and recommended guidelines for escape and rescue. Concepts examined include escape to orbit in a stand-by tug, rescue by a tug from lunar orbit, escape in EVA and IVA modes, use of unpressurized and cabin-type rovers for escape and rescue transportation, and use of an EVA surface-to-orbit escape system.

5.1 LUNAR SURFACE BASE ESCAPE/RESCUE SITUATIONS (Hazard Study 19, 20)

The lunar surface base will include living quarters for the base personnel, laboratories, science equipment, mobility vehicles for lunar traverses, electrical power generators, landing sites for lunar lander tugs, communications, and equipment needed to support the base operation, and possibly a propellant depot. The living quarters and laboratory may be elevated (on top of the propulsion module), surface mounted, or buried to obtain sheltering from the lunar environment including solar flare radiation. These configurations have an effect not only on the types of hazards which may arise, but also on the ingress and egress requirements of escape and rescue. Typical base hardware elements are shown in Figure 4-1. In this Figure the base proper is elevated, sitting on top of a lunar lander propulsion module. This configuration places severe technical requirements upon the escape and rescue mission. The removal or escape of an incapacitated crew could involve the use of an elevator. Placing the base facilities on the surface relieves the dependency of escape or rescue on elevators and/or ladders, and may offer the opportunity of docking cabin rovers directly with the base. Buried bases may require elevators or ladders, but these may be inside the base in a shirtsleeves environment.

An additional factor in escape and rescue is the type of ambient atmosphere and pressure of the surface base. Denitrogenization is required of the crew

in a transfer from an oxygen-nitrogen atmosphere to the space suit environment. The time needed to denitrogenize is 3 or more hours, depending upon the techniques used, and this amount of time could influence the escape and/or rescue mission.

The separation between the lunar surface base and the normal tug landing site is assumed to be about 1-1/4 nm. This requirement limits the possibility of damage to the surface base because of tug explosion and lunar soil ejecta stirred up by the tug engines, but at the same time the separation influences escape and rescue timeliness. The operational phases of the lunar surface base consist of initial manning and activation, routine operations, and deactivation.

As presently conceived, the base proper is landed unmanned. Manning and activating the base could require that the initial crew live temporarily in a lunar lander tug, and perform a number of construction tasks. For example, the base may need leveling, or a surface mounted base may need sandbagging. These types of outside activity raises the possibility of personnel injury.

The routine operations phase consists of housekeeping activities, outside exploration and, periodically, logistics resupply and crew rotation.

The deactivation phase will probably consist mainly in preparing the base for storage, deactivating nuclear power plants (if any), removing salvageable equipment and instruments from the base, and loading the tugs.

The general situations during the base operations are listed in Table 4-1. There are significant differences between the initial and final phases and the routine phase of the base operations. During activation the base may not be habitable. Hence, a bad landing could leave the crew stranded on the lunar surface without a safe haven available. During deactivation, there may be no safe haven available should the tug fail during liftoff. In either case, the crew compartment of the tug may provide a safe haven for some time assuming that the integrity of the crew compartment has not been violated. The "worst" case for these situations is where the crew must resort to space suits and portable life support systems for survival. This class of emergency situations can be summarized as one in which the crew

survival is limited by portable life support systems, and there is no primary vehicle available for leaving the surface of the Moon.

In the initial manning and activation phase, or during routine operations, the men may become trapped and/or injured inside the lunar surface base. This might occur as a result of an inoperable air lock or a critical failure.

The routine operation of the base includes IVA and EVA situations after the base has been established. In the EVA situations, there will be only a fraction of the crew on EVA while the other members of the crew are inside the base (or in tugs during the other phases of base operations). Hence, a rescue can be mounted by the base crew, and the base offers a safe haven to which the EVA crew may be removed. In the IVA situations, there may or may not be a portion of the crew on EVA. If a portion of the crew is on EVA, it may be possible for the EVA crew to help those inside a disabled base. The base crew may be evacuated to the parked tug.

A particular IVA situation is where the majority of the crew in the lunar surface base are incapacitated to a point where they cannot help themselves. They require aid to correct the problems on-board the base, and to prevent further deterioration of their position. Subsequently, they may need evacuation, and help to perform this evacuation. The lunar lander tugs will nominally land or be parked up to approximately 1-1/4 nm from the lunar surface base. The incapacitated personnel probably cannot make this journey unaided. In addition, they need a crew to fly the tug from the surface to escape to orbit.

If a minority of the crew is incapacitated, the situation probably requires no rescue operation. The incapacitated crew members can be cared for by the other base personnel until arrangements can be made for their evacuation.

Typical situations in the vicinity of the base during routine operations are shown in Table 4-2. Lunar rover vehicles are at the base or on traverse. Extravehicular suits and mobility vehicles are available, including pressurized stretchers. There is one tug near the base for each six men at that base. In addition, there is a standby rescue tug in lunar orbit.

Cases 1, 2, and 3 of Table 4-2 differ from those of 4 through 8 in that the latter are connected with a transition situation. That is, the presence of a second crew and lunar landing tug is due to a logistics resupply and crew rotation operation. This mode of operation may last about two weeks. The arrival and departure of the lunar lander tug is keyed to the position of the lunar orbit space station orbit plane. For the lower latitudes, the polar orbit plane passes within one degree of the lunar surface base about every 14 days. Cases 1, 2, and 3 prevail for the remainder of an approximate 2-month logistics cycle.

Case 1 requires rescue from orbit because there are no crew members available in the vicinity of the base to render help. A rescue crew must be landed near the base. They may walk to the base or use a surface vehicle that has been brought with them. Once they have reached the base, they may use transportation equipment stationed at the base to transport the incapacitated crew to the ascent vehicles. One member of the rescue crew will have to operate the tug carrying the evacuees on its ascent. The tug crew capacity will be limited. The rescue could therefore require the use of two or more tugs. If eight men can be carried to lunar orbit in one tug and the base manning level was 6 men, only one tug will be needed for evacuation.

Cases 2 and 3 are potentially surface rescue situations. This is because the crew on traverse may return to the base. They may render aid and transport the incapacitated crew to the parked tug. They may also pilot the tug to lunar orbit. Rescue could be required if the team on traverse requires a longer span of time to reach the base than the response time of a rescue tug, or if the traverse crew's residuals are near exhaustion.

Cases 4 through 8 are surface rescue situations requiring a parked tug(s) to return to lunar orbit. The crew outside the lunar surface base can effect the removal of the incapacitated crew and pilot the ascent vehicle(s). Case 8 is a special case in that the men in the tug are preparing to return, which means that the plane change will be small during this time period. This crew, if they react quickly, may get the incapacitated crew to the tug

in time for a normal return to orbit.

The following "worst case" situations determine the general requirements of the rescue plan.

1. During initial manning and activation or base deactivation, the primary liftoff vehicle is inoperable and the crew of six is surviving on portable life support systems.
2. During routine base operations, (a) all six men are trapped or are incapacitated inside the base, or (b) the base emergency occurs when the men on EVA have only a partial PLSS residual.
3. During a crew rotation mission, eight men are trapped, or are incapacitated inside the base, four men are elsewhere. The logistics tug is available on the surface.

An escape plan may be appropriate where the minority of the crew members are incapacitated in the emergency. In some cases, where crew members are outside the base during an emergency, the outside crew may render help, followed by an escape if a suitable vehicle is available.

An escape is feasible if the base personnel have the capability to help themselves. Conversely, if the base personnel are not capable of helping themselves, the need for rescue is apparent. The critical factor is whether a majority of the crew in the base are incapacitated or not.

Figure 5-1 shows the possible rescue options, given an emergency on-board the lunar surface base which leaves the majority of its crew members incapacitated. The evacuation of personnel proceeds via the orbiting lunar station, the Earth-Moon shuttle (either nuclear or non-nuclear), the Earth orbit space station, and the Earth orbit shuttle. This assumption rules out the use of a direct shot back to Earth with an Earth reentry (Apollo style).

For the case where the majority of the crew is in normal condition, the plan is to escape to a parked tug where the crew may proceed to orbit or wait for a lunar lander tug to pick them up.

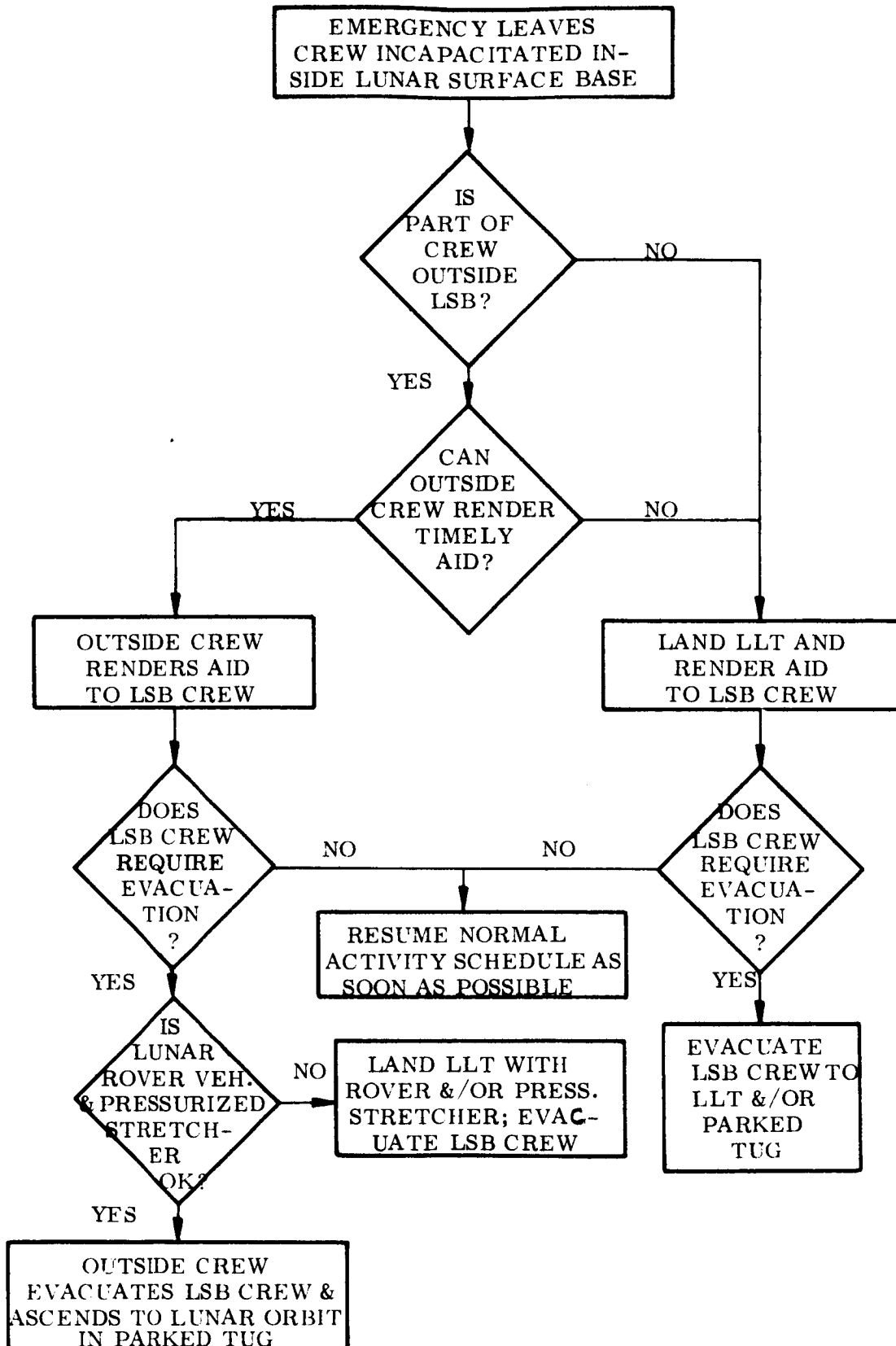

Fig. 5-1 Rescue Options

5.2 LUNAR SURFACE BASE ESCAPE/RESCUE CONCEPT DEFINITION

The situations described above suggest the following escape/rescue approaches:

1. Escape (Figure 5-2)
 - a. Escape via IVA
 - b. Escape via EVA
2. Escape/rescue (Figure 5-3)
 - a. Integral temporary shelter and rescue
 - b. Detached temporary shelter and rescue
3. Rescue
 - a. Lunar orbit rescue (Figure 5-4)
 - b. Surface crews rescue (Figure 5-5)

TO ORBIT

- 1. SPACE STATION ORBIT
- 2. OTHER

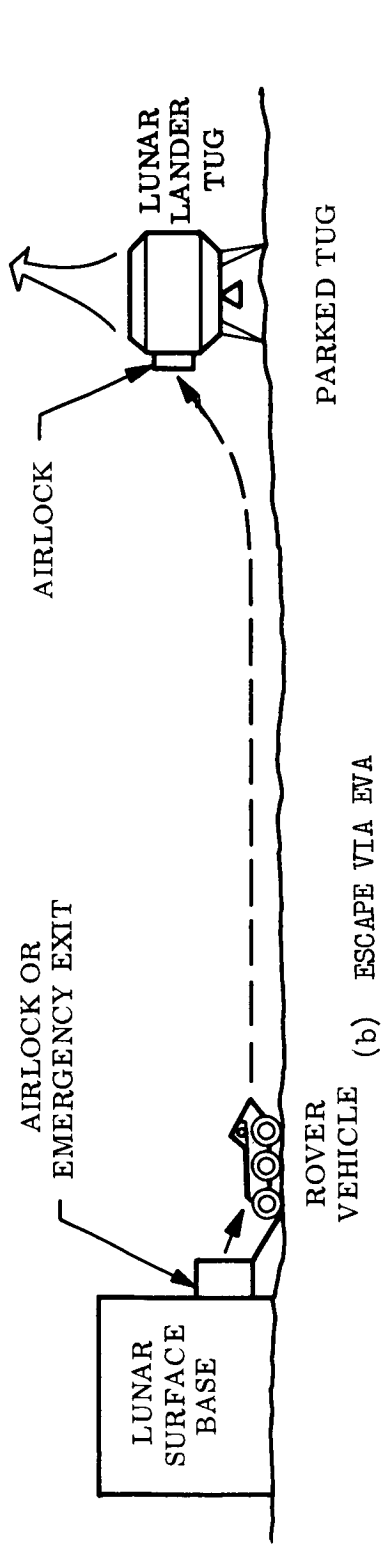

(b) ESCAPE VIA EVA

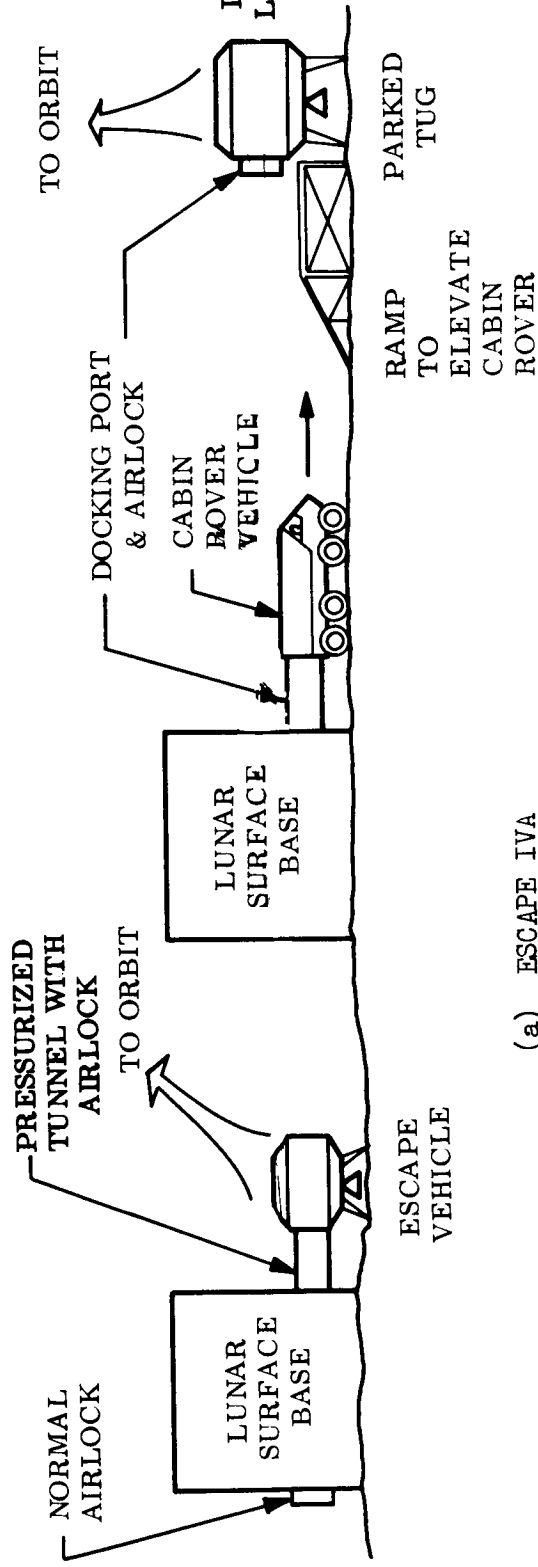

(a) ESCAPE IVA

Fig. 5-2 Candidate Escape Concepts

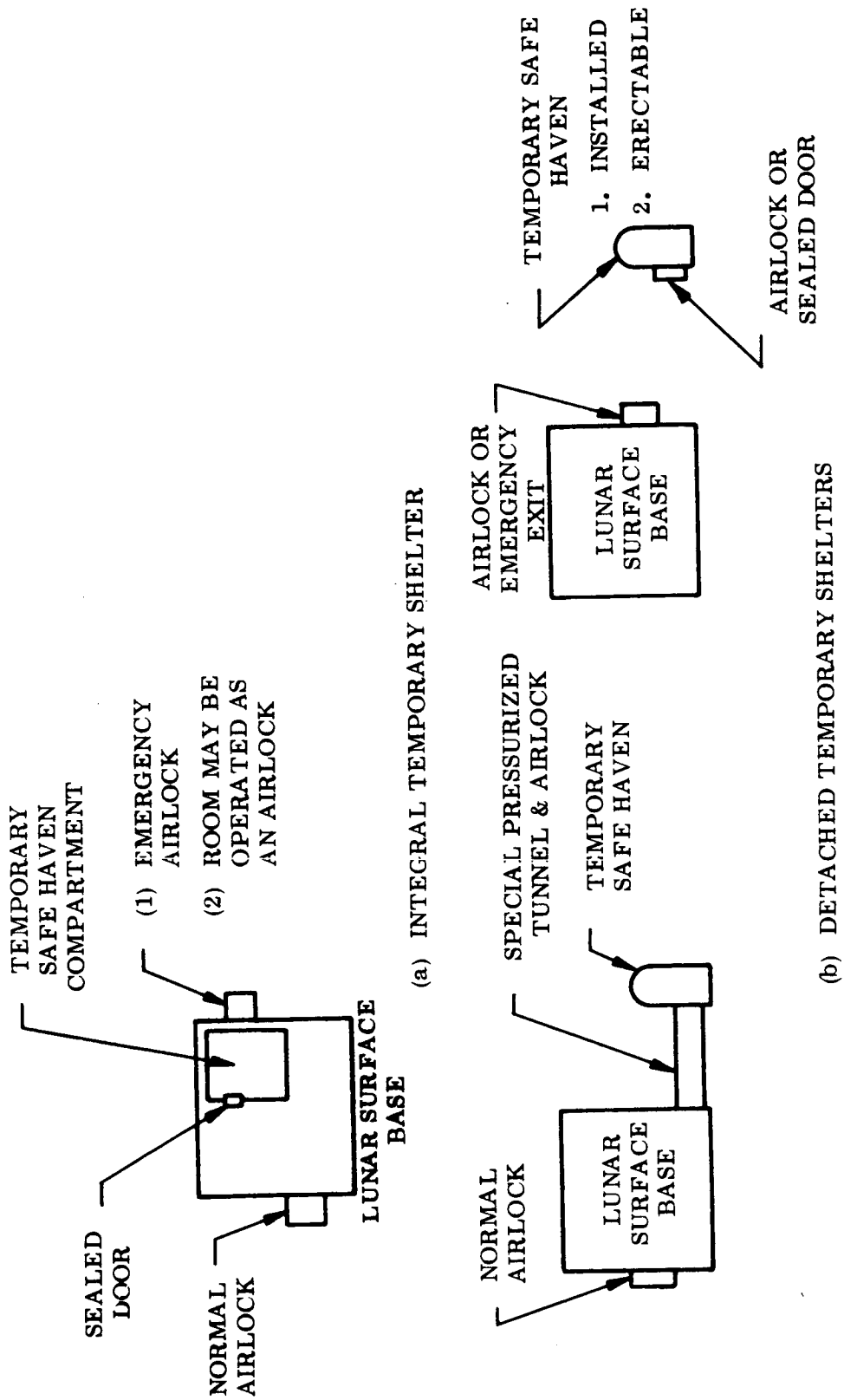

Fig. 5-3 Candidate Escape/Rescue Concepts

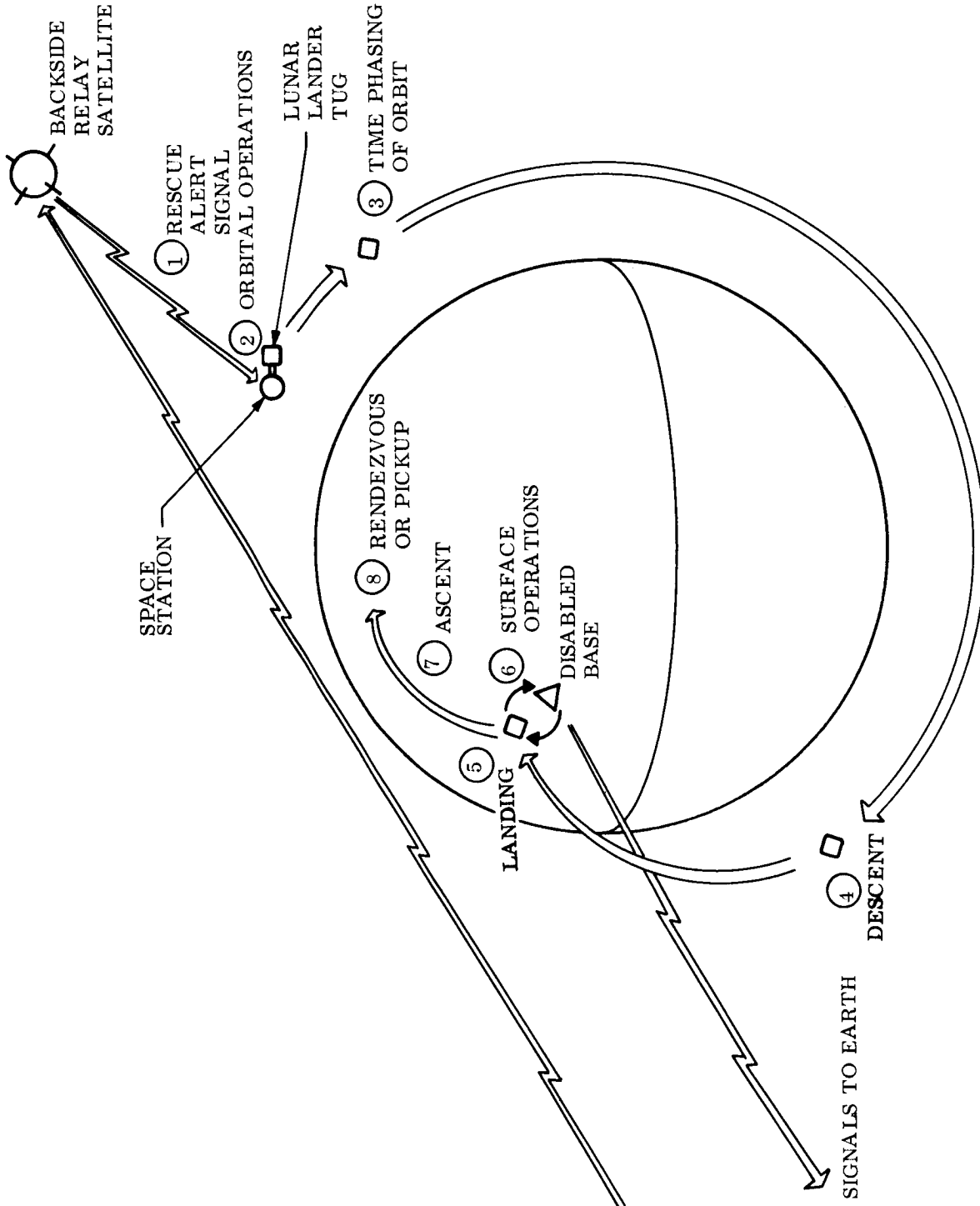

Fig. 5-4 Candidate Concept for Rescue from Lunar Orbit

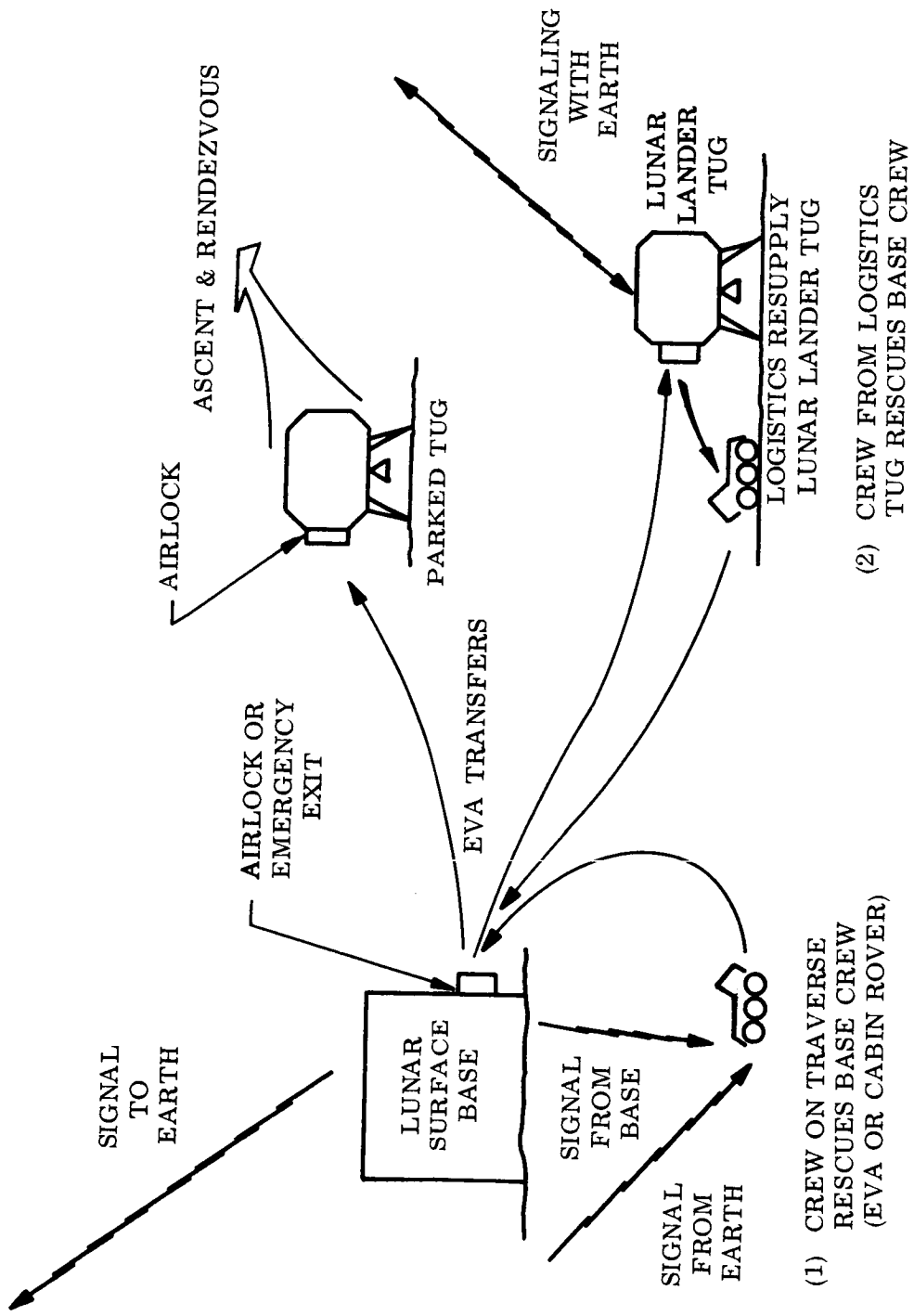

Fig. 5-5 Candidate Concepts for Rescue of Surface Crews

5.3 LUNAR SURFACE BASE ESCAPE/RESCUE OPERATIONS ANALYSIS

The operations involved in the basic escape/rescue concepts are shown in Table 5-1. The commonality of operations are indicated by X's. However, the details of the operations vary according to the concept. The following analysis steps through the operations shown on the Table to: (1) establish the nominal timeliness of the operations and their relationship to the parameters of the escape/rescue mission, and (2) determine equipment features and performance requirements necessary for the conduct of the operations.

5.3.1 Operations from Rescue Alert to Ready for Rescue Tug Separation

The operations from rescue alert to separation encompasses (1) the signaling of the control center, (2) the rescue decision making function, and (3) orbital operations in the preparation of the rescue vehicle for descent (in the case of a rescue) or the space station tug for rendezvous with an escape vehicle. These three are discussed below.

5.3.1.1 Rescue Alert Signal

Communications are needed for escape and rescue in order that the following functions be fulfilled:

1. Sending an S.O.S. via base to Earth or orbiting lunar station, base to EVA crew or parked tug, and EVA crew to base, parked tug, or Earth.
2. Verifying S.O.S. and explaining the nature and intensity of the emergency.
3. Coordinating activities of stranded crewmen and rescuers, and coordinating rendezvous of escape vehicle with other space elements.
4. Providing location aids.

The latter is mainly confined to disabled EVA crews signaling the base as to their location. The first three functions are common to all base situations.

The rescue alert signal is sent from the lunar surface base to the Earth vicinity. It may also be sent directly to the orbiting station or orbiting

Table 5-1 OPERATIONS OF BASIC ESCAPE/RESCUE CONCEPTS FOR LUNAR SURFACE

	Rescue Concept			
	Rescue from lunar orbit. Rescue crew in LLT.	Rescue from Surface		Escape
		Rescue crew on EVA traverse.	Rescue crew in parked tug.	
<u>Operations</u>				
<u>A. Alert to Separation</u>				
1. Rescue alert signaling	X	X	X	X
2. Rescue decision making	X	X	X	X
3. Orbital operations	X	-	-	-
<u>B. Separation to Touchdown</u>				
4. Time phasing of orbit	X	-	-	-
5. Descent & landing	X	-	-	-
<u>C. Surface</u>				
6. Egress from rescue vehicle	X	-	X	-
7. Unload mobility vehicles	X	-	X	-
8. Traverse to disabled base	X	X	X	-
9. Ingress into disabled base	X	X	X	-
10. Egress from disabled base	X	X	X	X
11. Traverse to return vehicle	X	X	X	X
12. Load rescue vehicle	X	X	X	X
<u>D. Return to Orbit</u>				
13. Time phasing for ascent	X	X	X	X
14. Ascent to orbit	X	X	X	X
15. Rendezvous	X	X	X	X
16. Transfer of rescue crew	X	X	X	X

tugs provided that these elements are in line-of-sight of the base. In any case, the Earth vicinity must be able to contact the lunar orbit elements as soon as is possible. In the worst case, the emergency occurs when the orbiting lunar station just passes into the communications shadow of the Earth-to-Moon link. This delay may amount to as much as one-half period of the station, i.e., 1 hour for a 60 nm orbit altitude. If a backside relay is provided, the delay time is negligible.

Alternate ways of contacting the orbiting station may be envisioned, e.g., lunar orbit relay satellites (refer to Appendix B). However, it is most important to contact Earth vicinity as well so that the Mission Control Center can institute any required verification procedures in the decision making process.

The absence of signals from the lunar base may also be interpreted as an emergency situation. This may occur if a time check to Earth of the orbiting station is missed. This type of warning must be avoided if at all possible because (1) it adds delays to the alert signal, and (2) it provides no information about the status of the base so that an intelligent rescue plan can be instituted. Any automatic S.O.S. should, if possible, indicate the nature of the disturbance causing the S.O.S.

The nominal time to alert Earth vicinity and the lunar orbiting elements is approximately 15 minutes, provided that a backside relay is available. Without the latter, the alert time to the lunar orbiting elements may be as much as 1 hour.

Because of the necessity for communications, the surface base must have a redundant, independently powered emergency communications system. The system should be capable of communicating directly with Earth vicinity. A two-way system is required so that the base crew can confirm the reception of its signals to Earth vicinity, and verify the contents of its original message to the satisfaction of the Earth base. During the foreseeable future, the lunar surface base will be located on the Earth side of the Moon so that it will always be in line-of-sight with the Earth.

The surface-to-surface communications in the vicinity of the base are required to alert any crew members on EVA traverse, or in the parked tug. However, an emergency link to Earth vicinity will also accomplish the same end because (1) the Earth vicinity facility can relay messages to all lunar surface units, and (2) the emergency line-of-sight communications can be picked up by lunar surface crews with appropriate receivers out to a range of several miles. The emergency system antenna should transmit to the lunar surface as well as to Earth. The mobility vehicles, tugs, and space suits should be equipped with a receiver capable of intercepting any emergency signals from Earth vicinity.

Conversely, the EVA crew, or crew in mobility vehicles and parked tug should have emergency communications with the base and Earth vicinity. Hence, two-way emergency communications gear are required on the space suits and vehicles.

An emergency communications system will solve the problem of equipment failure by providing redundancy. What it does not solve is the lack of communication because of the incapacity of the crew in the surface base.

The absence of signals from the lunar base may also be interpreted as an emergency situation. This absence will be noted when the Earth vicinity, orbiting station, and/or remote surface elements attempt to contact the surface base and receive no answer, or when the surface base fails to meet a scheduled check-in time. The failure of communications in this instance, where emergency communications have been provided, would be attributed to the incapacitation of all of the base crew or that part of the crew which is on duty. The nature of the hazard could cause the men on duty: (1) to become mentally confused or incapable of taking any kind of action, or (2) to evacuate the communications center. The latter may be averted by requiring that there be an alternate communications center in the base with access to both the normal and emergency communications equipments.

For an incapacitated crew, two approaches are evident. A bell or other signal

must be installed in the communications center and crew sleeping quarters which can be activated by a signal from Earth. Thus, Earth may try to arouse a sleeping crew if Earth fails to obtain a response to an inquiry. Secondly, the surface base should have an automatic S.O.S. system. The latter may be a time operated device working through the normal and/or emergency communications systems. Periodically, the duty crew would have to reset the timer. Failure to do so would alert Earth of a possible emergency. Alternately, the automatic S.O.S. could operate from sensors designed to detect under-pressure, oxygen partial pressure, toxicity, or abnormal temperature. This circuit could be a part of the on-board warning system.

The frequency of check-in times is keyed to the time effects of possible hazards on the crew. Hazards likely to cause crew drowsiness or mental confusion are heat prostration, carbon dioxide narcosis, and anoxia. The check-in frequency must be determined together with the warning system limits and the survival times of the crew associated with these limits.

With safeguards such as those pointed out above, the failure of communications would be detected within a check-in time interval, and would indicate the need for sending a rescue team to the base. The rescue situation would be characterized by:

1. An urgency of rescue response,
2. The expectation that the surface base crew would be of little help in effecting the rescue, and
3. The conditions in the base are unknown to the rescuers.

5.3.1.2 Rescue Decision Making

The bulk of the decision-making time interval will be used in verifying the rescue alert message and in determining the exact status of the disabled base. The reaction of the Escape/Rescue Control Center will be to recommend, and follow the progress of, remedial measures or escape at the lunar surface. If these are inadequate, or clearly inappropriate, the control center will evaluate alternate rescue plans, select one, and notify the proper space elements. In the event of a clear cut case of rescue, the Escape/Rescue

Control Center will be able to relay orders to the appropriate rescue elements in approximately 15 minutes.

5.3.1.3 Orbital Operations

The orbital operations of Table 5-1 pertain to a rescue mission from a vehicle located in lunar orbit. In the baseline situation, a space station, propellant depot, and a lunar lander tug are assumed to be in a polar orbit about the Moon. The lunar lander tug is docked to the space station. There may or may not be a primary transport vehicle at the space station or near by.

The first step is to alert the rescue crew and brief them on the rescue mission. The trajectory computations and rescue plan may be made on Earth or in the station concurrently with this activity. These operations may occupy as long as one-half hour for briefing the rescue crew.

Subsequently, the rescue crew is transferred to the tug. This operation will be IVA through the docking port. A lunar rover vehicle is required to be carried by the tug to serve as a backup mobility vehicle. This equipment should be standard equipment in the rescue tug and thus would already be loaded on the tug. Tug activation, check-out, and separation may require 20 to 45 minutes. The total orbital operation up to maneuvering for descent may occupy a minimum of from 50 to 75 minutes.

5.3.2 Operations from Rescue Tug Separation to Touchdown

The separation to touchdown operation applies to the concept of rescue from lunar orbit.

5.3.2.1 Time Phasing of the Orbit

The descent to the lunar surface must be accomplished so that the rescue vehicle can land near the lunar surface base. The time phasing of the orbit refers to the positioning of the rescue vehicle in the orbit for the first burn. It does not refer to the waiting for the orbit plane and the lunar surface base to become coincident. Consequently, the maximum time for phasing

is one orbit, or about two hours for a 60 nm orbit. This time phasing interval is not always concurrent with the orbital operations preceding launch. The rescue vehicle may remain docked to the orbiting station during most of the time phasing interval. Thus, the actual separation of the rescue vehicle from the station may occur any time during the time phasing, up to just before the first burn of the descent operation.

5.3.2.2 Descent and Landing

The rescue mission places the following requirements upon the descent and landing of the rescue vehicle:

1. The time to descend and land must be minimized to widen the survival time margin of the crew in the disabled lunar surface base.
2. The rescue vehicle must be able to perform the worst plane change without waiting. The plane change is $i + L$ or $180^\circ - |i| + L$ degrees, whichever is less than 90° , where i is the inclination of the rescue vehicle's orbit, and L is the latitude of the lunar surface base. If $i = 90^\circ$, and $L = 0$, a 90° plane change could be required.
3. The landing should be accurate to within a few hundred feet to allow the rescue vehicle to land as near the disabled base as permitted by the surface ejecta safety criterion.
4. The landing technique must be adaptable to all lighting and night conditions.
5. The landing field should be relatively smooth.
6. The descent should be performed so as to allow abort opportunities at each stage of the operation.
7. Options for saving ΔV during the descent, where feasible, should be provided so that the ΔV capability remaining after landing is maximized.

Abort capability can be provided by the vehicle design, e.g., providing two stages or redundant engines. However, it is best to use trajectory techniques to lessen the dependency of crew safety upon these expensive design

alternatives. The descent trajectories should be such that no new burn is required to prevent an impact on the lunar surface. This rules out the use of a short arc descent. An elliptical descent to a 50,000 foot perilune is recommended. A Hohmann transfer orbit provides this feature and at minimum energy expenditure.

It is desirable that the rescue vehicle be able to operate as autonomously as practical, particularly in the areas of guidance and navigation. The rescue vehicle landing error (using Apollo program error budgets) is estimated at 12,000 feet if a 90° plane change is required. A navigation update from some source external to the rescue vehicle (such as the LSB, orbital station, or Earth vicinity) would reduce this to a level of about 3500 feet. A technique that would permit rescue vehicle autonomous operation is to overfly the landing site after any required major plane change or other orbit maneuver has been accomplished. The vehicle could then track a landing beacon located at the landing site and compute a navigation update from these data. Large corrections could then be made prior to initiation of the powered descent initiation maneuver. Small corrections, based on approach tracking data from this same beacon, could be made during the powered descent phase. The latter technique should permit the rescue vehicle to land within a few hundred feet of the desired site.

The requirement for a 90° plane change is costly in terms of ΔV . A considerable savings in impulse velocity can be obtained by making the required rescue vehicle plane change at apogee of an elliptical orbit with perigee at the station circular orbit altitude. However, this velocity saving is obtained at the cost of an increase in elapsed time (response time) due to the elliptical orbit period increase. Figure 5-6 presents the tradeoff between this increase in elapsed time versus the corresponding decrease in the 90° plane change required ΔV .

3-Burn Descent - No Ellipse or Overflight

The trajectory for shortest time to descend from orbit altitude using a Hohmann transfer to a 50,000 feet perilune is shown schematically in Figure

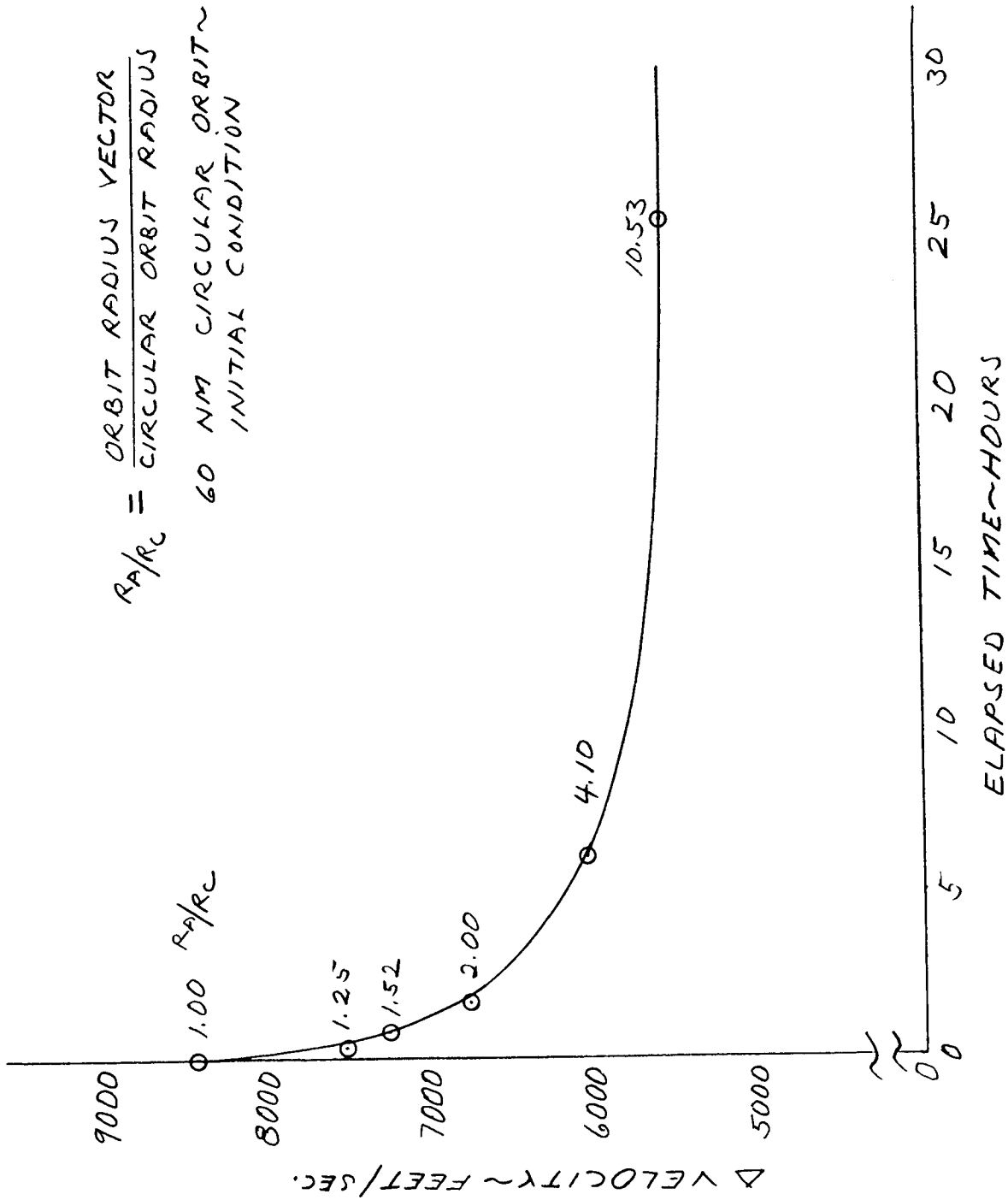

Fig. 5-6 Velocity Requirement for 90° Plane Change at Apolune

5-7. This trajectory does not provide any opportunity for an elliptical orbit nor an overflight of the landing site. The first burn is made 270 degrees from the landing site and makes the calculated plane change at orbit altitude.

After orbiting $1/4$ revolution, the second burn puts the vehicle into a Hohmann transfer ellipse to a 50,000 foot perilune. The third burn occurs at perilune, braking the vehicle and continuously powering the vehicle to within a few feet of the surface. Only one orbital maneuver is performed at each burn.

At about 125 nm from the landing site, the rescue vehicle comes within line-of-sight of the landing field. If a surface location beacon is tracked for about 30 seconds, the rescue vehicle can make a corrective maneuver at a maximum range of about 100 nm from the landing field. Assuming a maximum cross range error of 24,000 feet, the required correction ΔV is 218 feet per second. The total time for this descent is about $3/4$ orbit or 1- $1/2$ hours.

4-Burn Descent - Overflight, No Ellipse

In Figure 5-8 a method for more accurate descent by overflying the landing site is presented. In this case the first burn makes the major plane change 90° away from the landing site at an orbit altitude. The rescue vehicle flies over the landing site and tracks a location beacon at the site. When the vehicle is 270° away from the landing site, it makes a correction to the orbit plane, if required. At 180° away from the landing site, the third burn places the vehicle into a Hohmann transfer to 50,000 foot perilune. Subsequently, the landing is the same as that for the 3-burn case. In this approach, only one maneuver is performed at each burn. The total descent time is equivalent to 1- $1/4$ orbits, or 2- $1/2$ hours.

4-Burn Descent - Ellipse, No Overflight

The next trajectory (Figure 5-9) provides option for an elliptical orbit but no overflight of the landing site. The first burn occurs 90° away from the landing site, injecting the vehicle into an elliptical orbit to a higher altitude. At apolune, the second burn makes the major plane change and corrects

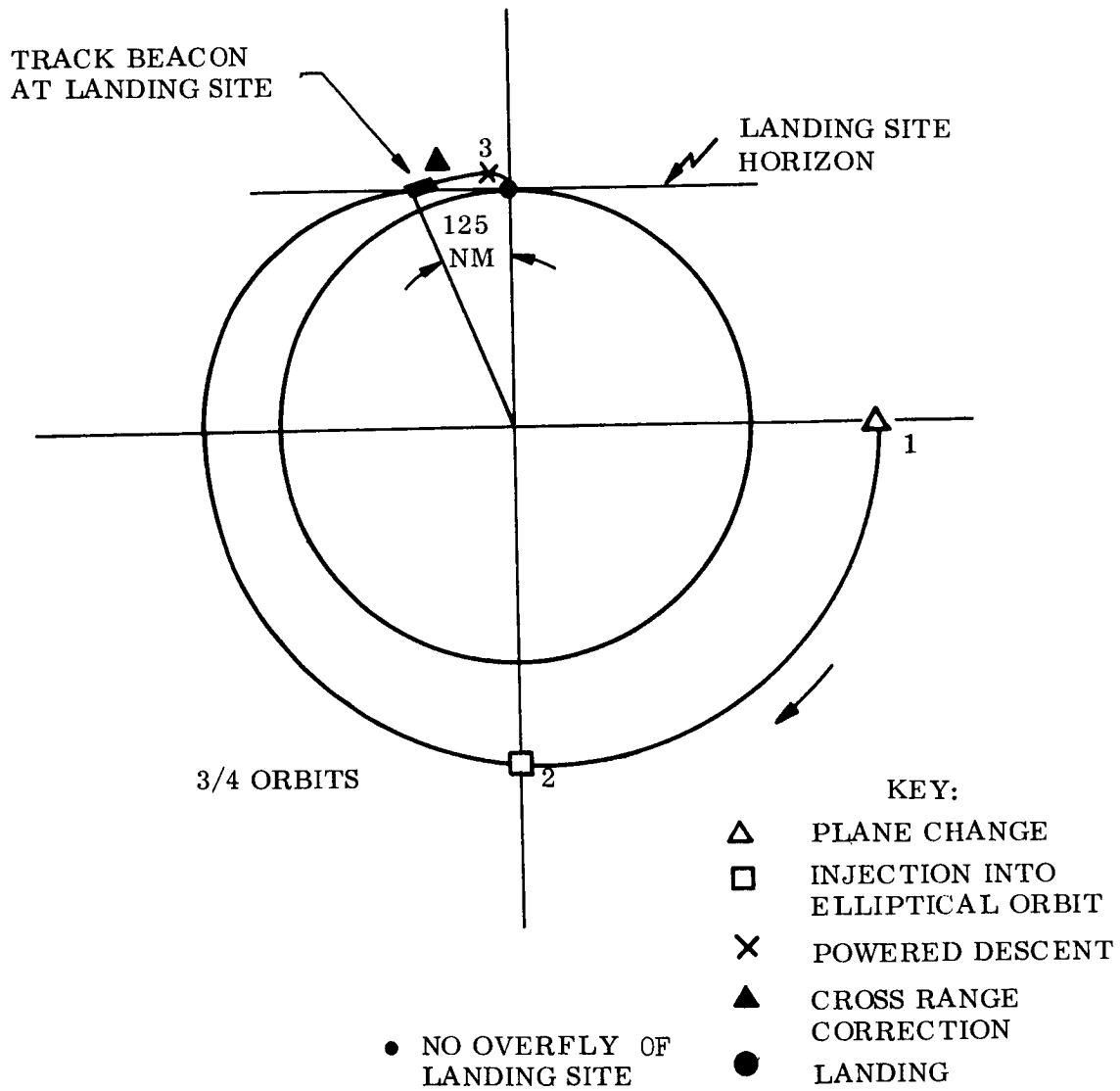

Fig. 5-7 3-Burn Descent

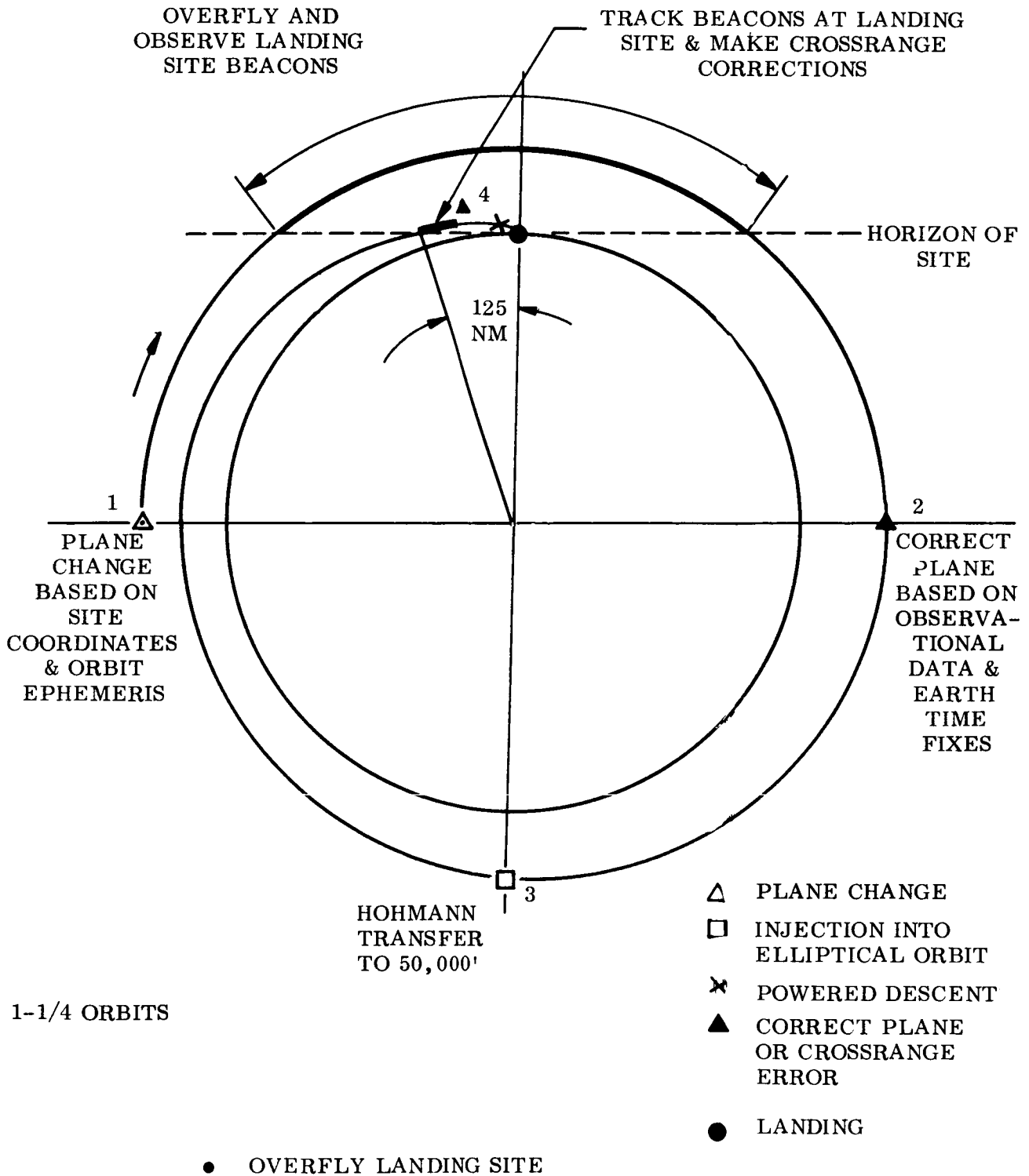

Fig. 5-8 4-Burn Descent

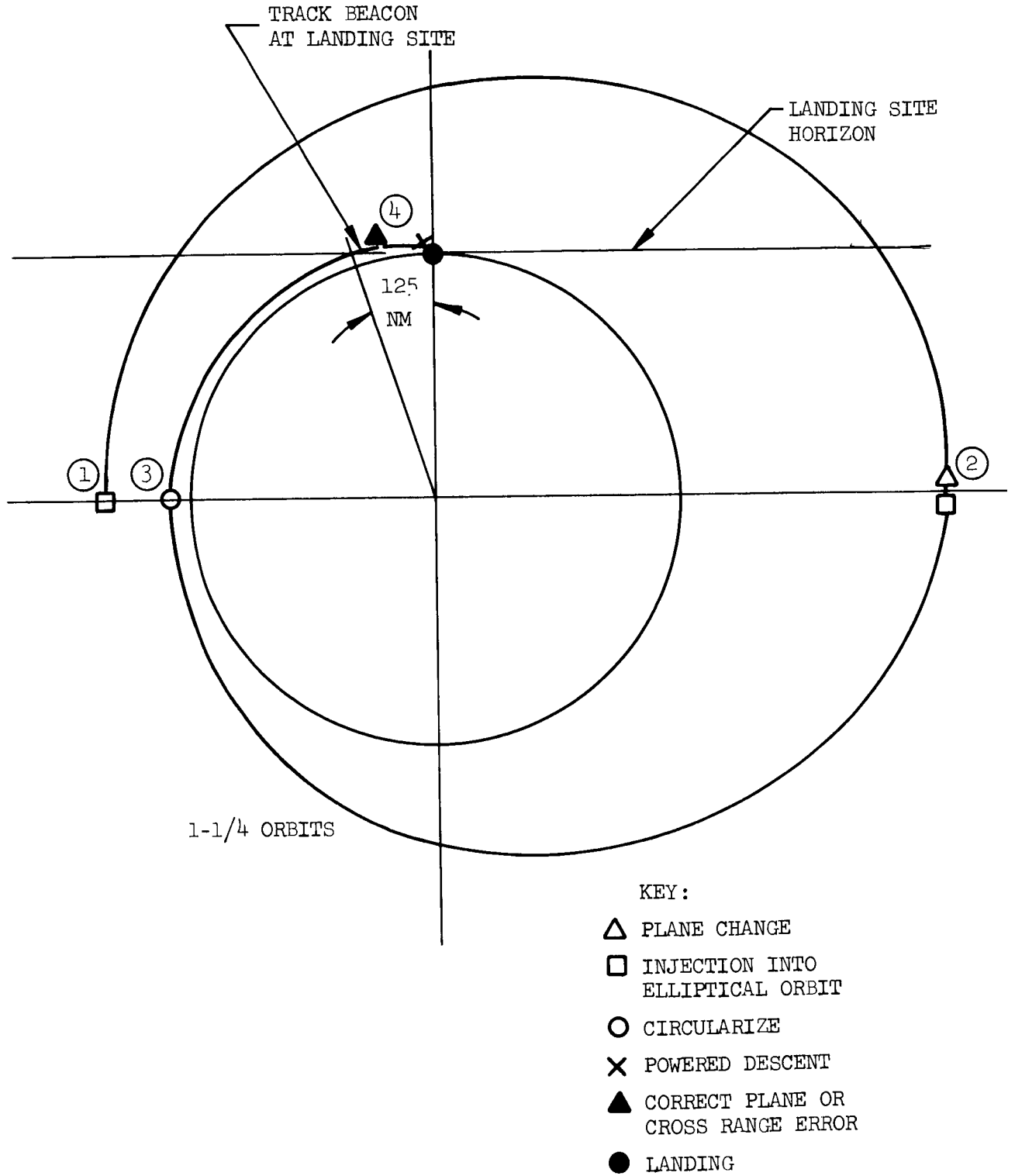

Fig. 5-9 Four-Burn Descent - Elliptical, No Overflight

the perilune to 50,000 foot altitude. At 90° away from the landing site, a third burn circularizes the trajectory at 50,000 feet altitude. The rescue vehicle will come within line-of-sight of the landing site at about 110 nm from the site. It may track the location beacon at the site and make cross range corrections. Burn 4 makes the powered descent. In this case, two maneuvers are performed at the second burn. The constant altitude approach to the landing site may have some advantages for tracking purposes. The total descent time is equivalent to 1-1/4 orbits or 2-1/2 hours or more depending upon the elliptical orbit apogee altitude.

5-Burn Descent - Ellipse and Overflight

The final case consists of an elliptical orbit option and an overflight of the landing site. In Figure 5-10 the first burn is 270° from the landing site and injects the rescue vehicle into an elliptical orbit to a higher altitude.

The second burn at apolune make the plane change. The rescue vehicle overflies the landing site as it descends to the initial orbit altitude. At perilune, the third burn makes a plane correction, if necessary, and circularizes the vehicle at the original orbit altitude. The 4th burn occurs 180° away from the landing site, injecting the rescue vehicle into an elliptical orbit with a 50,000 perilune. Subsequently, the vehicle tracks the beacon at the landing site and makes cross range corrections, if any. Burn 5 is the powered descent to landing. The third burn may perform two functions if a plane correction is required. The total time is equivalent to 1-3/4 orbits or 3-1/2 hours or more depending upon the elliptical orbit apolune altitude.

5.3.2.3 Crew Preparation (Denitrogenation)

During the time interval between separation and touchdown, the rescue crew must acclimate themselves to a space suit environment. The orbital station is assumed to have a normal Earth atmosphere. For those crewmen who emerge from the space station two-gas, 14.7 psi atmosphere, the acclimation consists

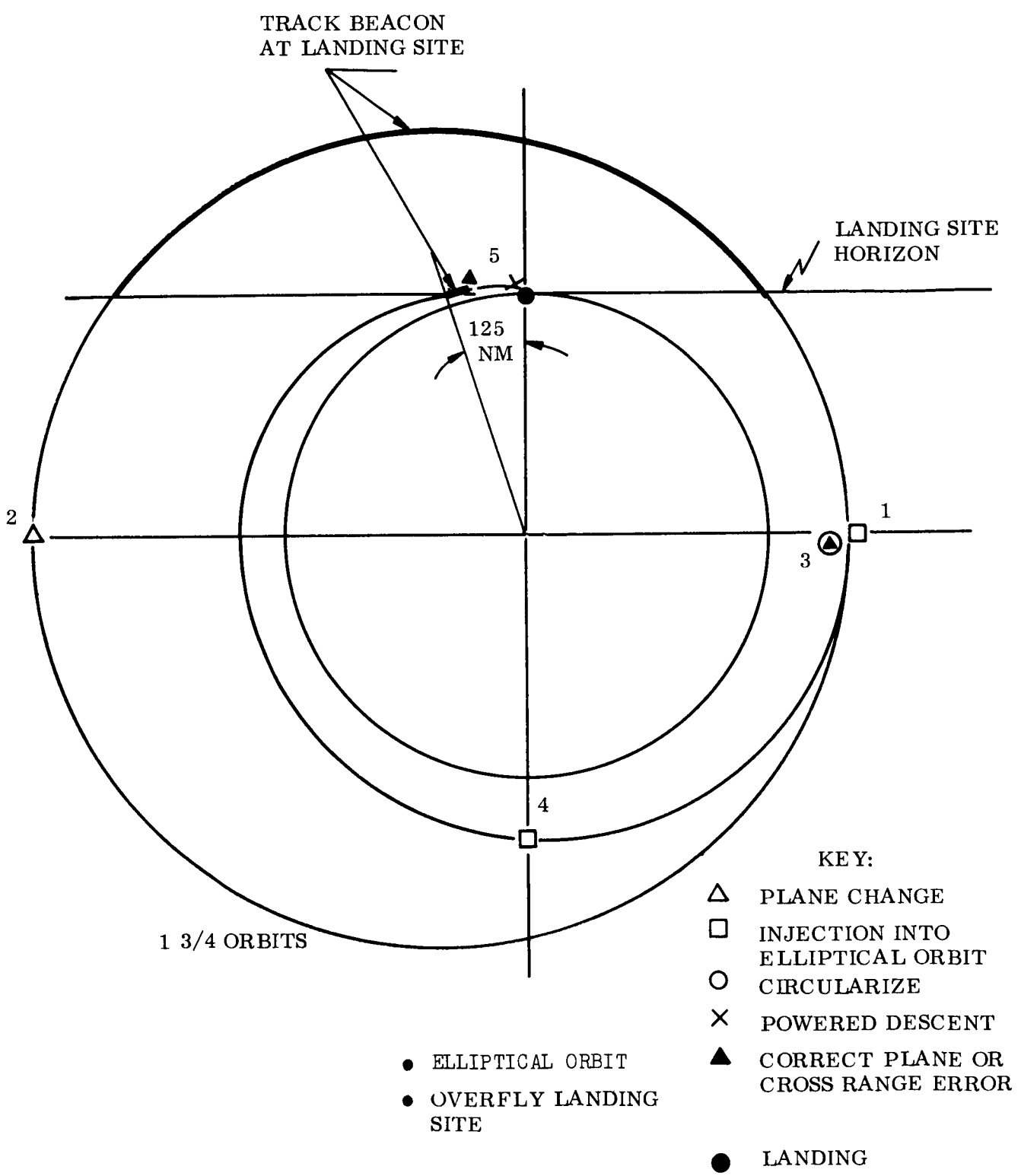

Fig. 5-10 5-Burn Descent

of pre-breathing pure oxygen at a total pressure of 6.8 psia or more. In this case, the pre-oxygenation period is about 3 hours. This time interval is sufficient to protect against most of the decompression sickness symptoms.

At separation the rescue crew will don space suits and begin to pre-oxygenate. They must perform the necessary descent and landing maneuvers while pre-oxygenating. Before landing, the crew compartment will be depressurized to 3.5 psia and the atmosphere changed to pure oxygen. After landing, the crew will don their space suit helmets and put on the portable life support units, and proceed to egress. The interval from separation to landing is adequate for denitrogenization for any of the descent schemes suggested.

5.3.2.4 Rescue Tug Descent Procedure

In order to be able to render assistance as soon as possible, the rescue plan requires that provisions be made to allow use of the 4-burn direct descent with overflight for time-critical rescue. This procedure requires a basic 7,300 ft/sec for descent and landing, plus provisions for an additional 7,550 ft/sec for a 90° plane change. Maximum time from separation to touch-down is 4.6 hours including 2 hours for orbit phasing.

The reliance on an elliptical transfer orbit descent to conserve ΔV carries too big a penalty in time for the saving in ΔV . Referring to Figure 5-6, reducing the 90° plane ΔV to 6,000 ft/sec requires an additional 5 hours, more than double the direct-descent time.

The allowance for an overflight in terms of time (one hour more than the 3-burn direct descent) is considered worthwhile in that the rescue tug can be autonomously capable of achieving the essential accuracy to land within 1/2 nm of the distressed crew. The necessity for landing accuracy is discussed in the succeeding section.

The capability to land at night and all sun angles is necessary to meet the above timeliness. Because the base is a fixed installation, the possibility of preparing a landing site is realistic. Beacons and landing site lights

may be installed. The landing site should be relatively smooth. It may be semi-hardened by chemical treatment to reduce the dust problem although this feature is not a requirement set by the rescue operation.

5.3.3 Rescue Operations on The Lunar Surface

Typical surface operations are shown in Figure 5-11. The timeliness and procedures of the surface operations depend on a number of system parameters including the following:

1. Distance between the lunar surface base and the escape or rescue vehicle.
2. Crew compartment pressurization and atmosphere.
3. Space suit pressurization and atmosphere.
4. Elevation of the airlocks above the lunar surface.
5. Capacity of the airlocks.
6. Capacity of the rover vehicles.
7. Velocity of the rover vehicles.

5.3.3.1 Landing Distance for a Rescue Tug

The nominal distance between the lunar surface base and the lunar lander tugs is one and one-fourth miles. This distance is required to give safety to the base from the surface ejecta stirred up by the tug engines and/or debris ejected by an exploding tug. A parked tug, either on standby or on a normal logistics resupply mission, should be located at this distance. However, this distance may be reduced for the rescue vehicle. The logic here is that the normal safety rule does not apply in the case of a rescue, the increased risk to the base hardware being offset by the increased efficiency in rescue.

Landing the rescue vehicle within 1/2 nm of the base will reduce trip times to the rescue vehicle by 60%. It also will enable the crew members, in a normal condition, to walk between the base and rescue vehicle.

In moving the landing distance from 1-1/4 to 1/2 nm, the particle diameter that could reach the base increases from 0.06 to 0.16 inches in the ejecta stirred up by a 10,000# thrust engine 5 ft. above the lunar surface. The

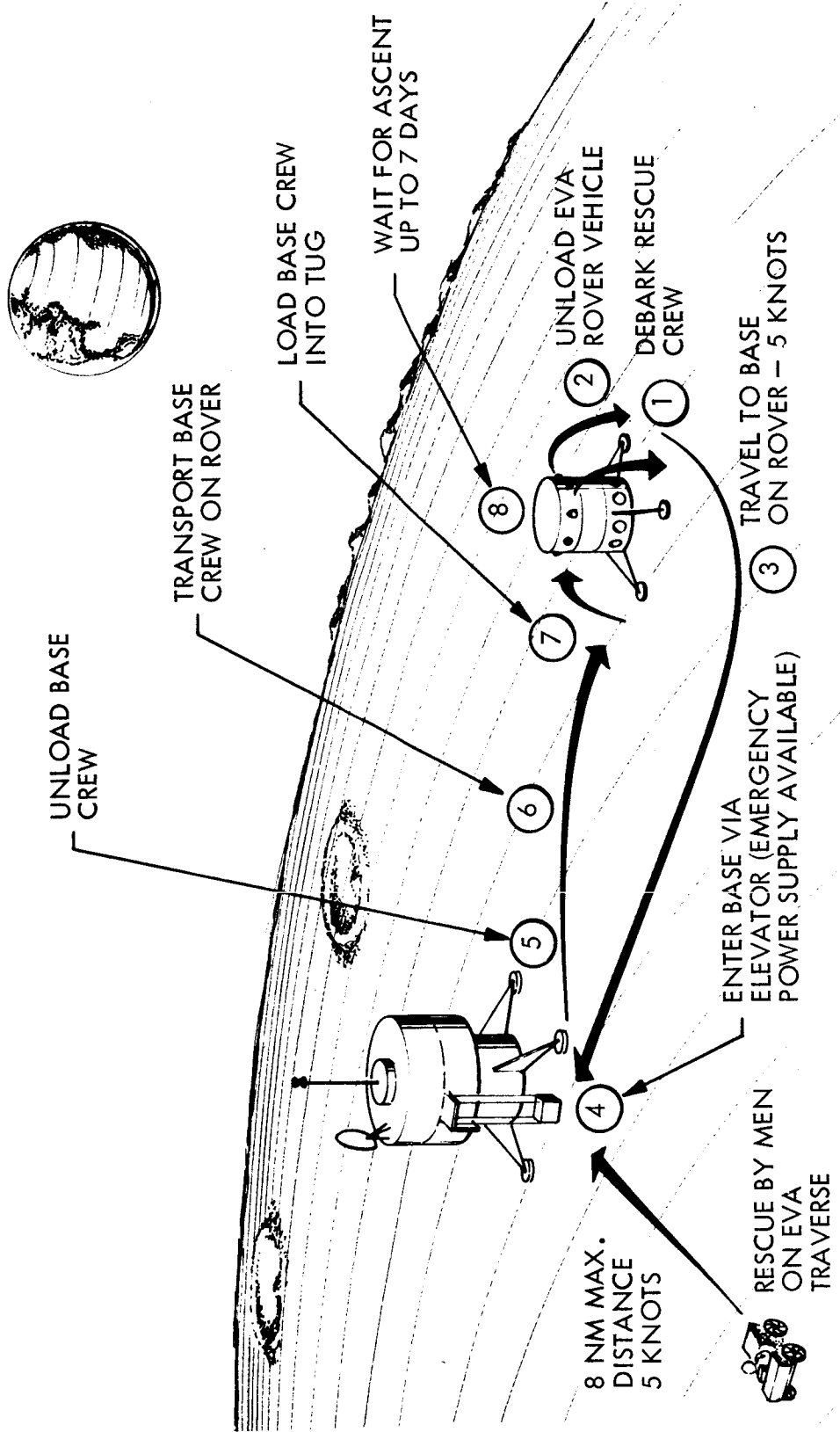

Fig. 5-11 LSB Surface Rescue Operations

probability of a hit is increased by a factor of about 2.5.

The IVA transfer of personnel from the base to the rescue vehicle would be possible if the rescue vehicle could land next to the base. This idea does not appear realistic at this time. The accuracy of landing has not been demonstrated sufficiently to permit the acceptance of this idea. No landing data is available for night landings or landings at unfavorable sun angles. Hence, the danger of a direct collision between rescue vehicle and base in a side-by-side landing cannot be ruled out at this time.

This analysis assumes that the rescue vehicle must land 1/2 to 1-1/4 nm from the base. It is also assumed that the rescue vehicle cannot move to the base (on tracks, for example) nor that an aerial tram is rigged between base and the rescue vehicle. These possibilities are considered too futuristic in this time period.

5.3.3.2 Denitrogenization of a Distressed Crew

The base crew compartment is generally assumed to be pressurized at 14.7 psia with a normal Earth atmosphere. This pressurization has the disadvantage of requiring a lengthy denitrogenization of the crew before their emergence in a standard space suit having a 3.5 psia, 100% oxygen atmosphere.

In an emergency, the crew may go directly to the space suit without pre-oxygenating. The onset of the symptoms of the decompression sickness is delayed according to the amount of work the men perform. Table 5-2 shows these delay times for about a 10% cumulative incidence of symptoms for a moderate exercise. This Table is derived from data for men going from a sea level atmosphere to the space suit environment.

Table 5-2
 TIME FOR OCCURRENCE OF 10% CUMULATIVE INCIDENCE
 OF SYMPTIOMS OF DECOMPRESSION SICKNESS

Initial Pressurization & Atmosphere	Final Pressurization & Atmosphere	
	7.5 psia (15,000' Equiv) 50% O ₂ - 50% N ₂	3.5 psia (35,000' Equiv) 100% O ₂
14.7 psia (sea level) 20% O ₂ - 80% N ₂	15 minutes* 45 minutes#	10 minutes* 30 minutes#
7.5 psia (15,000' equiv) 50% O ₂ - 50% N ₂		30 minutes* 90 minutes#

* For standard exercise consisting of 10 step-ups onto a 9 inch stool in 30 seconds every 5 minutes.

For 1/3 standard exercise.

The delays in feeling the decompression sickness may allow the crew members to perform some escape or rescue activity, or allow them to be moved passively in a rescue.

While the standard pressure suit has a 3.5 psia, 100% oxygen environment, it is possible for a suit to be constructed for a 7.5 psia, 50% oxygen atmosphere. This would have the advantage of being perfectly adaptable to a similar atmosphere in the cabin, or extending the delay time in the onset of decompression sickness symptoms if the cabin has a normal sea level atmosphere. The disadvantages are the restrictions placed on the movements of the men in the suit, its extra weight, its development costs, and the fact that it would be a dedicated safety gear probably without a practical use during normal operations.

5.3.3.3 Rescue Equipment Capacities

An elevated airlock requires the use of an elevator to raise and lower crew members who are not able to use a ladder or steps. This would include the pressurized stretcher. In addition, the docking of a cabin rover to the airlock would require either a large elevator or a ramp. Hence, the IVA transfer of crew members becomes complicated and impractical for the elevated base and tug. Even if the base is surface mounted, the lunar lander tug will probably be elevated. Emergency elevator power and control must be provided where elevators are present.

The capacity of the airlocks should accommodate two men in pressure suits, or one man in a pressure suit and one in a pressurized stretcher. Portable airlocks should have the same capacity. The airlock capacity affects the time it takes to evacuate or load a vehicle or the base.

The capacity and speed of the rover vehicles affects the number of trips and the trip time between the disabled base and the escape or rescue vehicle.

Each operation in the general escape/rescue procedures are examined below.

5.3.3.4 Egress from Tug Rescue Vehicle

The rescue crew may egress from the rescue vehicle through the airlock in a normal manner. This operation should occupy no more than 15 minutes especially if the pressure of the crew compartment has been reduced to 7 psia (50% O₂ - 50% N₂) or 5 psia (100% O₂). The rescue team would be prepared for EVA as was pointed out in the discussion of the preceding separation to touchdown sequence.

5.3.3.5 Unload Mobility Vehicle

The rescue vehicle will probably land at least 1/2 nm distance from the lunar surface base. The rescue crew has the option of walking to the lunar surface base. However, a rover vehicle will be needed to carry rescue equipment such as pressurized stretcher or portable airlock, and can provide both lighting, for night travel, and vital communications gear. In addition,

because the condition of the rover vehicles at the base are unknown, it will be a safer procedure to bring a fresh rover vehicle with the rescue crew. This vehicle would provide transportation for the rescue crew to the base and elsewhere. The time allowed to unload the rover vehicle from an unpressurized cargo compartment is 15 minutes, using a powered hoist.

5.3.3.6 Traverse to Disabled Base

For separation distances between $1/2$ and $1-1/4$ nm, a man walking at 2.7 knots (5 km per hour) will require from 10 to 30 minutes time to make the trip. A 3.5 knot rover vehicle will require from 8 to 20 minutes.

Some rescues may originate at the parked tug, usually the one which is on a crew rotation trip (Cases 4 through 8 of Table 4-2). In this situation the tug to base distance will be $1-1/4$ nm, and the longer times apply. In another rescue case (numbers 2 & 3 of Table 4-2, the crew on EVA may return to the base to perform the rescue. Assuming the range of the EVA rover is 16 nm, the maximum distance from the base would be about 8 nm. Hence, a 3.5 knot vehicle would require 2.3 hours to return to the base, and a five knot vehicle would require 1.6 hours. The traverses for Cases 4 through 8 of Table 4-2 would probably be performed during daylight. This is because the logistics vehicle will probably arrive at the base during the lunar day. In Cases 2 and 3 of the Table 4-2, the traverses will probably be in the daylight because of the inherent danger of night traverses far from the base.

For Case 1 of Table 4-2 the rescue rover vehicle brought by the rescue vehicle must be capable of night traverses at speeds of five knots. It should be capable of carrying a driver in a space suit, plus, at the least, any one of the following:

1. passenger in a space suit,
2. passenger in a pressurized stretcher, and
3. portable airlock.

The rescue rover vehicle must have a power supply capable of providing (1) all the traverse power requirements, (2) floodlighting for ingress and egress

operations at the base and tug, (3) emergency power for an elevator or hoist, and (4) power for wrenches or cutting tools to open sealed access doors in the base.

5.3.3.7 Ingress to Disabled Base

The status of the disabled base and its crew must be established by the rescue crew. If communications are normal, this status may be easily established by talking to the distressed crew. In other cases, however, the distressed crew may be too incapacitated to reply, or the crew may be ignorant of some of the problems on board the base. In particular, the crew may be isolated in a life support compartment, unable to check out conditions of the base elsewhere. Therefore, the second step in the process of ingress depends upon the information that the rescue crew can obtain from the base crew. The sequence of events and decision points are shown schematically in Figure 5-12.

An investigation of conditions on board the base is required if the information is inadequate. If the base crew is alert, but the communications are defunct, some form of simple emergency communications are assumed to be feasible. These communications could vary from a simple code pounded out on the base shell with a hammer, to plug-in voice circuits powered by batteries brought by the rescue crew. If the base crew is in satisfactory condition, they could proceed to egress when this signal announces the arrival of a rescue crew.

In investigating the condition of the base, the rescue team tests for pressure and atmospheric composition and contamination. The elevator (if present) and the airlock(s) are checked out. The required instruments must be brought in by the rescue team. It is desirable to be able to quickly locate the position of the crew in the base. Special emergency life support compartments could have an automatic signal that indicates its occupancy.

If the crew compartment is unpressurized, the rescue crew opens the airlocks and enters directly. In case the airlocks are inoperable, and to avoid having the rescue team cut a hole in the base shell, an additional emergency sealed door is needed to provide ingress/egress to the crew compartment. The door

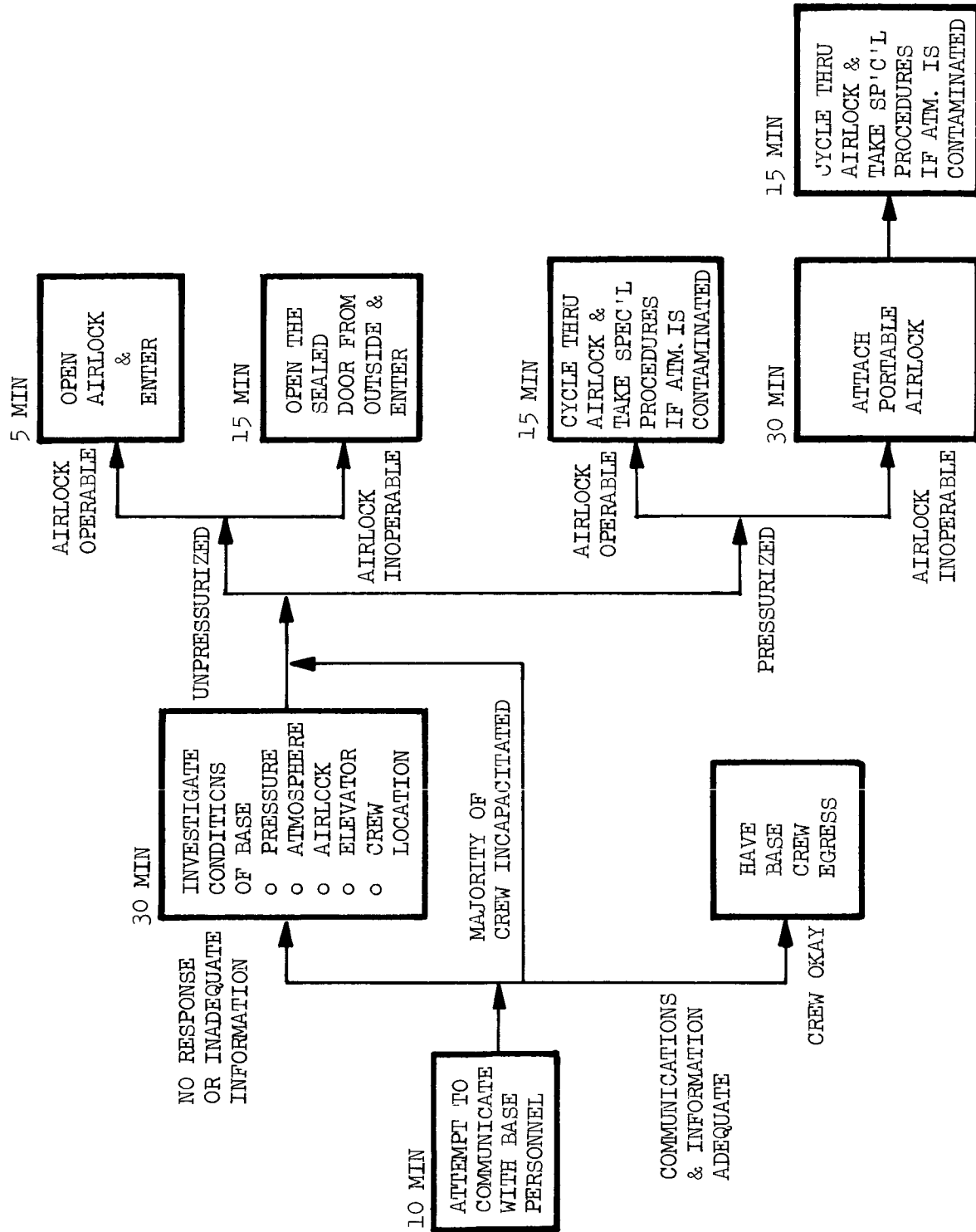

Fig. 5-12 Ingress of Rescue Crew into Disabled Base

should be operable from either side.

If the crew compartment is pressurized, an airlock is required for entry by the rescue team to avoid depressurization in case some of the survivors are still in shirtsleeves. If the regular airlock is inoperable, a portable airlock must be used. The portable airlock should be compatible with the sealed emergency door and sized to handle a pressurized stretcher and suited crewman.

Passage through the airlocks is conventional provided that the atmosphere in the base is not contaminated. If it is contaminated, the rescue crew will have to put on oxygen face masks after venting their suits in the airlock. Suit venting is required to prevent a pressure differential from developing in which the base pressure exceeds the suit pressure. The rescue crew should always use an oxygen face mask if the base atmosphere contains a second gas. This will keep the rescue crew denitrogenized allowing them to egress at any time.

The estimated times for the ingress operations are also shown in Figure 5-12 with a maximum of 85 minutes (1.4 hours).

5.3.3.8 Egress from Disabled Base

The most general escape/rescue procedure requires that the base crew egress in the EVA mode. Hence, a pressure suit should be provided for each person on board the surface base. Additionally, a pressurized stretcher must be provided for any individual who is injured and cannot be placed in a pressure suit. The pressurized stretcher may have an atmosphere similar to that of a space suit, or it may be pressurized to 7.5 psia with a 50% oxygen - 50% nitrogen atmosphere. While the latter prevents the effects of decompression sickness, it has the disadvantage of requiring a special portable life support system. The man in the pressurized stretcher will be passive throughout the operation. His decompression symptoms will not be severe. There is also the possibility that he can be pre-oxygenated before entry into the pressurized stretcher. Hence, the pressurized stretcher could have the same

atmosphere and pressure as a pressure suit.

In general, the base crew must accommodate themselves to a pressure suit environment. The able bodied crew members must be prepared to take an active role in the escape/rescue. They must definitely be denitrogenized because they will have to perform work in pressure suits.

The egress for EVA evacuation is discussed next, and subsequently, the alternative IVA transfer.

If the base has been depressurized, the base personnel will already be in pressure suits, or inside special life support compartments. In the first case, the time to evacuate is simply the time required to pass through doors or opened airlocks. In the second case, where the crew is in special compartments, the requirements are the same as those when the total base is pressurized. These requirements are that the personnel must don pressure suits (or enter pressurized stretchers) and must accommodate themselves to the space suit atmosphere.

An EVA egress, from a 14.7 psia normal atmosphere crew compartment is shown in Figure 5-13. The crew pre-breathes 100% oxygen for three hours at pressures greater than 6.8 psia, after which they may don pressure suits and go to a 3.5 psia 100% oxygen atmosphere. The crew may egress through the airlock, or if the latter is inoperable, they may depressurize the whole cabin, open a sealed door, and egress through this opening. As an alternative, the crew could don pressure suits built especially for 7.5 psia and a 50% nitrogen - 50% oxygen atmosphere.

If the lunar surface base normally has a 7.5 psia 50% nitrogen - 50% oxygen atmosphere, the crew may pre-breathe 100% O₂ for two hours, and then don the standard pressure suits, as is shown schematically in Figure 5-14.

It seems best to employ standard pressure suits for the escape and rescue purposes. The suits are not dedicated. The denitrogenization time may occur concurrently with the response time of the rescue system in the case of rescue. It is recommended that the pre-breathing of pure oxygen be carried out, because

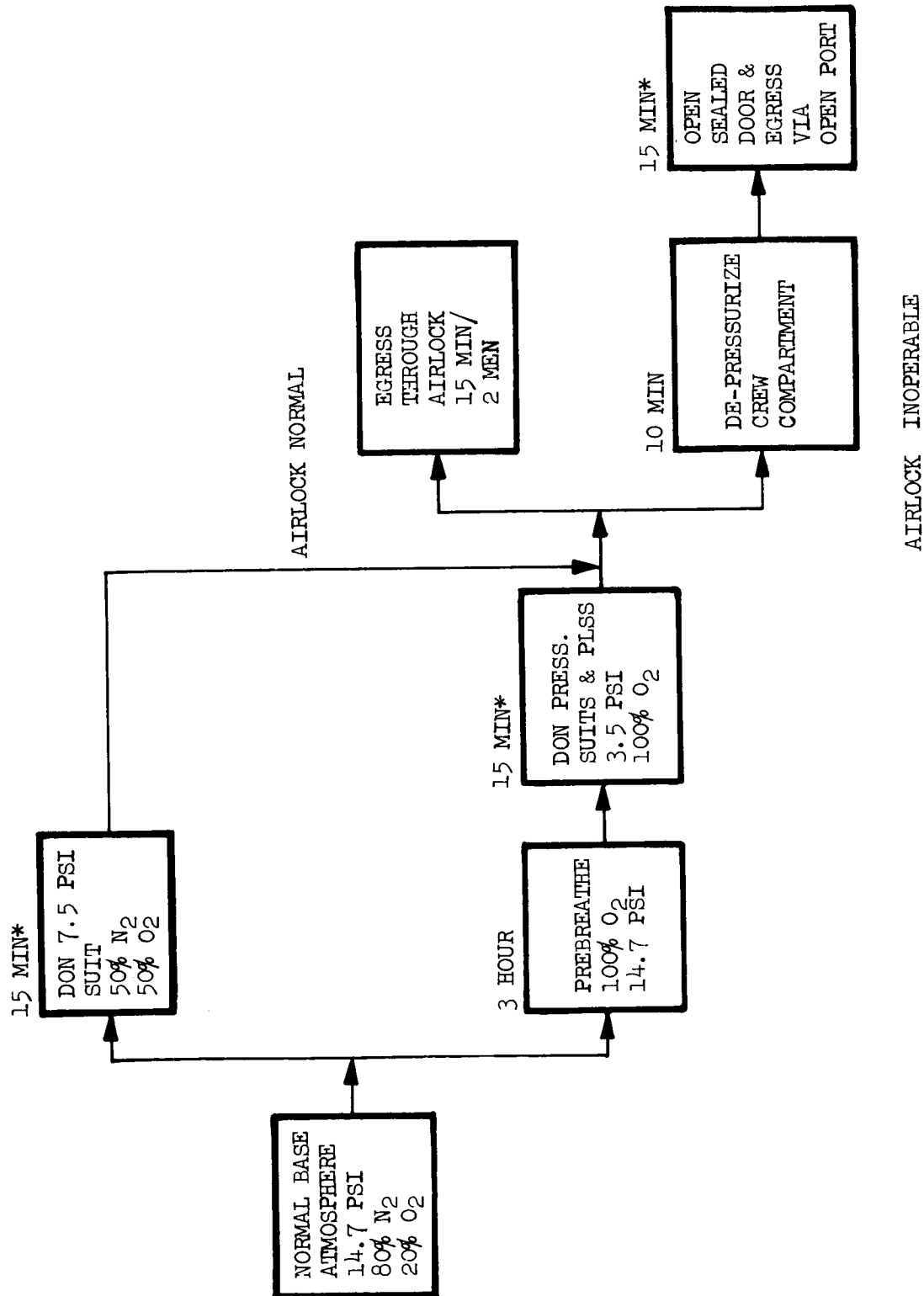
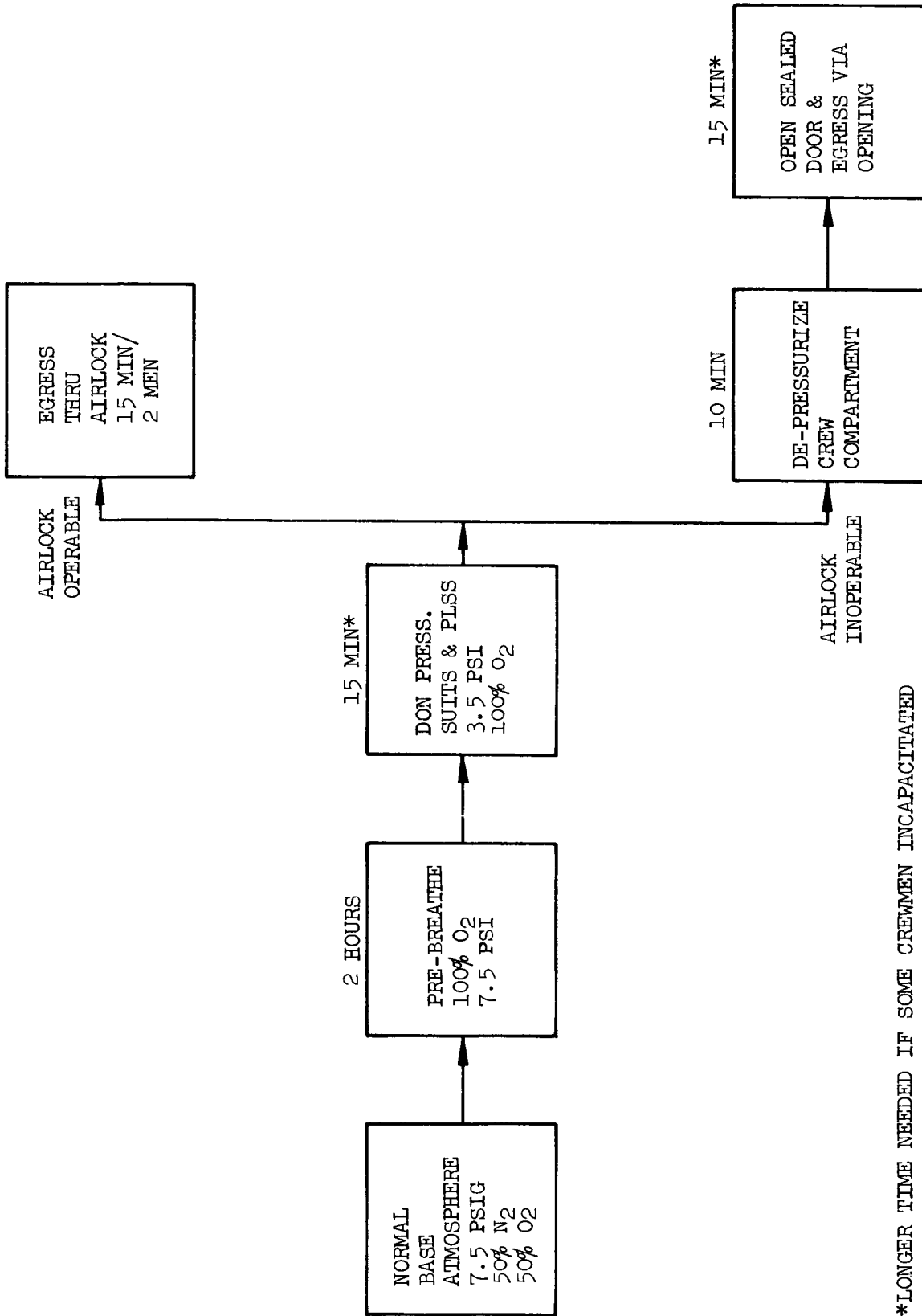

Fig. 5-13 EVA Egress of Crew from 14.7 psi Atmosphere Disabled Base



*LONGER TIME NEEDED IF SOME CREWMEN INCAPACITATED

Fig. 5-14 EVA Egress of Crew from 7.5 psi Atmosphere Disabled Base

the men who are not incapacitated will have to perform some work in the escape and rescue operation.

The internal, special life support compartment must be compatible with the requirements for an egress in the EVA mode. Each compartment (if more than one) must be a virtual airlock so that it can adjust pressures from the normal base pressure to zero. This is because of the possibility that the base may accidentally become depressurized, or is deliberately depressurized to facilitate the egress or rescue crew ingress. The compartment must accommodate a pressurized stretcher so that injured personnel can be prepared for egress. The compartment capacity must be commensurate with the total base population. Case 6 of Table 4-2 sets this limit at eight people, but that is based on a nominal population of six.

Each compartment must have a sealed door to the exterior. Hence, in the event of an inoperable main airlock, the men may egress from the opened sealed door, using the compartment as an airlock.

The pressure suits should be stowed in the special compartments so that the men have only one operation to perform in case of a serious emergency - viz., enter the special compartment(s). The compartments must provide a means for pre-oxygenating at pressures above 6.8 psia.

The compartments are required to contain an autonomous life support and pressurization system. Thus, the lunar surface base would have a redundant life support and airlock system.

In the event a critical failure occurs in the special compartment, that compartment is simply sealed off from the rest of the base.

The alternative plan of providing an external shelter is not a substitute for the special internal compartment unless a pressurized tunnel is constructed between the base and the external shelter. Otherwise, the base crew is faced with the problem of egressing in the EVA mode to gain a temporary safe haven. An external emergency shelter may be needed to provide a temporary safe haven for the outside crew who may return to the disabled base with depleted portable

life support residuals. However, this latter requirement is not coupled with the egress of the base crew from the base.

The IVA transfer of the base crew from the base to the rescue vehicle depends upon the capability to dock a pressurized cabin rover vehicle to the base and also to the rescue tug. Practicality dictates that the base and tug crew compartments be relatively near to the lunar surface level. The pressurized cabin rover vehicle must be docked to the base when not in use. It need not dock to the base airlock because it has its own airlock. However, its airlock must be capable of pressurizing to the base pressure, which will generally be greater than the 5 psia cabin rover pressurization. The alternative is to dock to the base's airlock which can then reduce the pressure to that of the cabin rover. This procedure is not general, however, because the base's airlock may be inoperable in the emergency. The cabin rover pressure will be compatible with the rescue vehicle if the latter is reduced to 5 psia during rescue, as was previously recommended.

In summary, the general docking requirements are as follows:

1. The base airlock must be compatible with the cabin rover docking mechanism.
2. The base must have a sealed door to which the cabin rover can dock.
3. The cabin rover airlock must be capable of pressurizing to the normal base pressure.
4. The rescue vehicle airlock must have the capability to dock with the cabin rover, or an alternative docking port.

5.3.3.9 Traverse to Tug

The time to traverse between the base and the return vehicle will be about 15 minutes based on a maximum separation distance of 1-1/4 nm and a 5 knot rover vehicle speed. A distance of 1/2 nm reduces the traverse time by 60%. If both the rescue vehicle at 1/2 nm and the parked tug of 1-1/4 nm are used to evacuate the personnel, the trip time is reduced 30%. However, reducing trip times does not reduce the total evacuation time correspondingly if egress and loading times are greater than individual trip times. The driver of the traverse vehicle must return to the base to pick up new personnel. Hence,

the driver will be one of the rescue crew. In the case of the cabin rover used for the transfer of the rescued crew in the IVA mode, the driver should be in a pressure suit at all times. (This requirement implies that the cabin rover has redundant external controls.) This has the advantage of freeing the cabin for more rescued men, and also allowing the driver to perform tasks on EVA more easily.

It is possible that the movement of the traverse vehicle could be remotely controlled by a RF link so that no driver would have to go with the vehicle. However, the loss in speed under remote guidance would probably be a greater penalty than carrying a driver. For a two-man vehicle, the loss of more than one-half the speed would make the remote guidance procedure less effective than carrying a driver. For larger vehicles, the payoff of remote guidance would be even less attractive.

The main disadvantage of the escape approach technique of entering the cabin rover in the IVA mode, thus ignoring docking and pressurization hardware penalties, is the fact that the rescue vehicle would have to bring a cabin rover with it in order to be certain that an operational cabin rover was available. This disadvantage is reason enough to place the transfer method, based on the IVA mode, as a secondary approach.

5.3.3.10 Load Escape/Rescue Tug

The general requirements for the loading of personnel in the EVA mode onto the escape or rescue vehicle are as follows:

1. Access to the rescue vehicle must be compatible with the transfer of passive crew members in space suits.
2. A means for transferring personnel in pressurized stretchers is required.
3. The crew capacity of the rescue vehicle must be compatible with the combination of number of rescue crewmen and evacuees.

The transfer of personnel in the IVA mode using a cabin rover vehicle requires the following:

1. A means to dock the cabin rover with the rescue vehicle.
2. A means of equalizing pressures between the cabin rover and rescue vehicle.

If the crew compartment of the rescue vehicle is at a higher level with respect to the traverse vehicle, an elevator or hoist must be provided to meet the requirements of docking above. The elevator or hoist could be carried by the traverse vehicle. For the transfer in the IVA mode, a ramp must be provided. The maximum slope of the ramp should be less than thirty degrees. This is based upon the mobility requirements of the cabin rover vehicle for surface exploration.

Two methods of transfer in the EVA mode are evident. The rescue vehicle may be pressurized, say at 5 psia and 100% oxygen, when it lands. In this case the rescue vehicle must have an airlock. The airlock must accommodate two men in pressure suits, or one suited man and a pressurized stretcher. In the second method, the rescue vehicle is depressurized before the rescue crew egresses. Life support umbilicals are required so that crew members who are loaded into the depressurized rescue vehicle may plug in their suits, and the pressurized stretcher may also be connected to the life support system.

The first method is superior as far as the rescue is concerned. In this method, the rescued crew may get to a shirtsleeves environment earlier. This will be especially valuable to an injured person in the pressurized stretcher; it will be difficult to medically treat a crewman in the stretcher. In addition, the stretcher could be used again for another man. The disadvantage of this method is the size of the airlocks needed to accommodate a stretcher.

The second method exposes the rescued crew to a pressure suit environment for a longer period of time. It does not materially shorten the total evacuation time interval because the loading can be concurrent with the trips between the rescue vehicle and base.

Another possibility is to fasten the pressurized stretcher on the outside of

the rescue vehicle, and recover the stretcher after the rescue vehicle and space station rendezvous. This procedure is probably not acceptable, however, because the man would have to remain in the stretcher for a long length of time. The minimum is 4 hours for ascent. In addition, there is the waiting time on the surface of the Moon before takeoff. This time interval can be substantial as is described later.

A large volume airlock may be provided in the rescue vehicle by designing one of the regular compartments in the vehicle to have the capability of changing pressure and atmosphere, and having an internal and external pressure door.

The preferred rescue method via the EVA mode is to place the rescued men in a shirtsleeves environment at the earliest time in the rescue vehicle.

For transfer in the IVA mode, the rescue vehicle must have a port capable of docking with the cabin rover vehicle. If the cabin rover has an airlock, the docking port need not be placed on the airlock of the rescue vehicle. A 5 psia 100% O₂ crew compartment atmosphere is compatible with the current cabin rover designs. The docking adapter could be an inflatable or expandable structure.

5.3.3.11 Crew Base-to-Tug Transfer Time

In the case of the previous three items (egress from disabled base, traverse to return vehicle, and load rescue vehicle), the following analysis gives typical total times for evacuation of a distressed crew. In this analysis, it is assumed that the base crew have been properly pre-oxygenated, and are in pressure suits or are ready to be placed in pressurized stretchers. Four operations are considered: disembark base crew from disabled base, traverse to tug, return to base, and load base crew into tug. Part of the rescue crew is at the base, one rescue crew member pilots the rover vehicle, and the balance of the rescue crew is at the tug to help load the base crew aboard.

For purposes of this analysis, each of the four operations is assumed to

require one-fourth hour, and assumes one man is capable of handling an incapacitated crewman on and off the rover and in and out of the airlocks.

The total time for evacuation is made up of intervals needed for debarking base crew, rover vehicle travel time from base to tug and return, and loading crew on board the tug. Some of these operations may be carried on concurrently, depending upon the availability of rescue crew members to help the incapacitated crew members, or the capability of the latter. The time intervals for rescue ends when the last incapacitated man is aboard the tug in a shirt-sleeves environment. The time that is required for the rescue crew to enter the tug(s) is not counted.

The time required to remove six crewmen from the base and place them in the safe haven is determined in a parametric form for a base-rescue tug spacing of $1/2$ and $1-1/4$ nm, 2 and 3 man capacity surface vehicles, and 2 and 3 man rescue crew. The results are shown in Table 5-3. Total traverse distance of the surface vehicle is a function only of its capacity and the spacing. The total distance is the same for 2 or 3 rescue crewmen. Rescue time is most sensitive to spacing and surface vehicle capacity. Increasing the rescue crew from 2 to 3 decreases the rescue time only fractionally for the same capacity and spacing. Based on these results, a surface vehicle with minimum 3 man capacity is recommended for rescue of six or more men. This is reaffirmed when considering the total time the rescue crewmen are required to be outside the rescue vehicle, as is shown on Table 5-3. Allowance will have to be made for a spacing of $1-1/4$ nm in the worst case as discussed in the next section on return to the orbiting lunar station.

5.3.4 Escape/Rescue Tug Operations to Return to Orbit

The return operation is common to both escape and rescue. Its purpose is to take the crew from the lunar surface to the station in lunar orbit. This may be accomplished by

1. waiting on the surface of the Moon for a co-planar ascent with no plane change required,

Table 5-3
CREW EVACUATION TIMES

EVA Rover Capacity	Time to Rescue 6 Crewmen		Total Rover Traverse Distance (nm)		
	Number of Rescue Crewmen		Distance (nm)		
	2	3	Spacing		
	1/2 nm	1-1/4 nm	1/2 nm	1-1/4 nm	
Two Men	Evacuation Time	4.5 hr	1.6 hr	3.25 hr	7 hr
	Rescue Crew EVA Time	5.3 hr	4.05 hr	6.15 hr	
Three Men	Evacuation Time	3.25 hr	1.25 hr	2.0 hr	4 hr
	Rescue Crew EVA Time	4.95 hr	3.7 hr	4.9 hr	

2. making an ascent plane change with the escape or rescue vehicle to complete rendezvous with the station, or
3. making a zero plane change ascent with the escape or rescue vehicle, and relying on an orbital vehicle to rendezvous with the escape or rescue vehicle.

In the absence of an orbiting lunar station, the escape or rescue vehicle could

1. wait on the lunar surface for an opportunity to rendezvous with the primary transport vehicle in lunar orbit,
2. go to a lunar orbit and wait to rendezvous with a primary transport vehicle from Earth,
3. go into lunar orbit, and, if necessary, rendezvous with a propellant depot, refuel and return to Earth orbit either in the plane of the Earth orbit space station, or some other orbit, or
4. refuel on the lunar surface, if necessary, and go directly to an Earth orbit if tug ΔV capability permits.

Direct flights to the Earth with Earth reentry are ruled out because the penalties associated with the required reentry equipment are not compatible with the planned lunar hardware elements.

The total time required to return a crew to Earth orbit is the time required to attain a lunar orbit plus the time waiting for an opportunity to arrive at the Earth space station orbit with zero plane change. The latter opportunities occur every ten days for a 55° inclination Earth orbit. Waiting for the primary transport vehicle, in lieu of returning to Earth orbit in a space tug, could easily double this time. However, with an orbiting lunar station available, there is usually no great urgency in returning a crew member to Earth because the space station should have medical facilities capable of coping with most injuries. An isolation capability should be available on both space station and escape/rescue vehicle to prevent contagious diseases from being transmitted via the environmental and life control systems. The main emphasis of this analysis is concerned with the return to a lunar orbit.

5.3.4.1 Operational Modes for Lander Tug Escape/Rescue Missions

The alternative operational modes for lunar surface rescue missions using the lander tug are to either time phase (waiting) the descent trajectory with that of the orbital station or to decouple the descent and ascent ΔV . To have the capability to perform an anytime, all point, direct rescue mission is too expensive from a ΔV requirement viewpoint.

Time phasing consists of an orbit time phasing and a surface waiting time to obtain a favorable angle between the lunar space station orbital plane and the lunar surface base. The waiting for the station orbital plane to change with respect to a point on the lunar surface must take place at the lunar surface base. The angle between the space station polar orbital plane and a lunar site is shown in Fig. 5-15 as a function of time. The largest plane change rate is 13.2 deg/day at the equatorial latitude and decreases with increases in latitude.

The ΔV available to the escape/rescue vehicle determines the required on-surface and on-orbit waiting time span. Fig. 5-15 shows that if the escape or rescue vehicle can wait on the surface, or survive, for up to 14 days, the space station orbit will be coplanar with the lunar surface base sometime within this waiting period. This mode is applicable for non-time critical rescue missions and represents the minimum ΔV requirements. The ascent ΔV can be decoupled from the descent ΔV provided (a) a dedicated, fully loaded escape vehicle which is located on the surface of the moon is used, or (b) the rescue vehicle is refueled on the lunar surface. If an escape vehicle is used, its performance requirements are similar to those for a lander tug in orbit which performs a 90 degree plane change and descends. In this case, the need for a rescue lander tug is obviated by the escape tug, and the time for the distressed crew to reach a safe haven in orbit is minimized.

If no escape vehicle is provided or if it is unable to perform the escape mission, the crew must be rescued. Table 5-4 shows the ΔV required to perform the various descent and ascent maneuvers. The amount of ΔV required for a 90 degree plane change is a function of the base orbital altitude and the orbital altitude at which the plane change maneuver is performed. A

more thorough discussion of lunar surface plane change requirements is presented in Appendix A along with alternative operational modes to a three burn ascent and plane change maneuver. The ΔV data for the five burn ascent/descent mission for Table 5-4 is discussed in Appendix A. If the rescue vehicle is required to make an immediate descent with a 90 degree plane change (three burn sequence), it has already expended 14,850 ft/sec. Consequently a 15,000 ft/sec rescue vehicle would serve as a temporary safe haven for the distressed crew and could provide some limited medical assistance, but could not return to orbit. The rescue and distressed crews are in effect stranded and would have to wait for outside help to refuel the rescue vehicle or to transfer the distressed crew for return to the orbital lunar station. A rescue vehicle with 15,000 ft/sec ΔV capability that did not have to make a plane change on descent would be able to make an ascent with no plane change but could require a waiting period of 14 days if the rescue operations become extensive.

Rather than using the rescue vehicle for return, a standby tug may be available at the lunar surface base. If it has been completely refueled, it is capable of

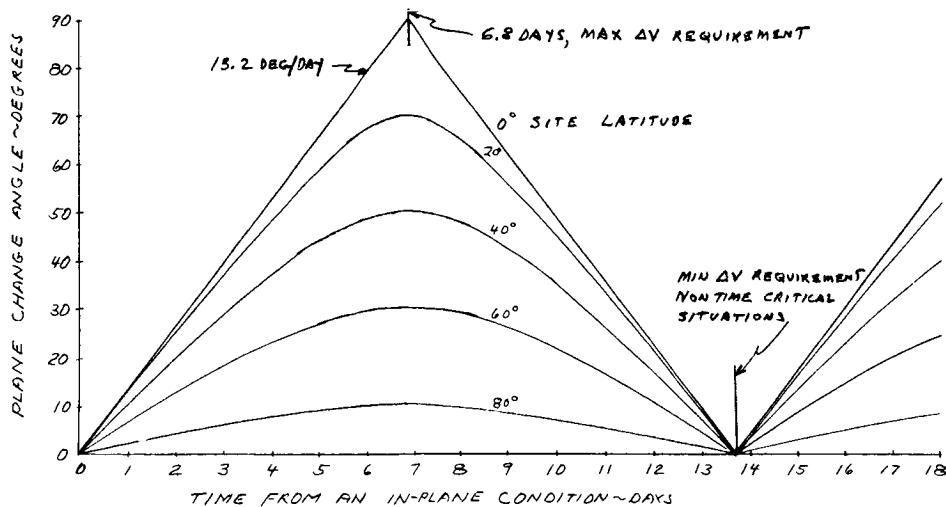

Fig. 5-15 Angle Between Lunar Station Polar Orbital Plane and a Lunar Surface Site vs Time

returning immediately with 90° plane change. If it is not refueled it would still have the capability for ascent with no plane change with the attendant wait of up to 14 days. To use the standby tug for return of the distressed crew means transporting them over a distance of at least 1-1/4 nm rather than 1/2 nm as discussed in the previous section on Crew Evacuation Time.

In general, a 14 day emergency survival capability is recommended.

Table 5-4

Δ V REQUIREMENTS FOR RESCUE ORBITAL MANEUVERS 60 NM POLAR ORBIT

<u>Event</u>	<u>3-Burn Ascent/ Descent Sequence</u>		<u>5-Burn Ascent/Descent Sequence With 24 Hr. Elliptical Orbit</u>	
	<u>Δ V Ft/Sec</u>	<u>Cum.ΔV Ft/Sec</u>	<u>Δ V Ft/Sec</u>	<u>Cum.ΔV Ft/Sec</u>
90° Plane Change	7,550	7,550	4,800	4,800
Descent & Landing	7,300	14,850	7,300	12,100
Ascent & Insertion	6,690	21,540	6,690	18,790
90° Plane Change	<u>7,550</u>	<u>29,090</u>	<u>4,800</u>	<u>23,590</u>
Total		29,090		23,590

5.3.4.2 Escape/Rescue Tug Ascent to Orbit

The main requirements for the ascent is that the procedure be simple and safe. The simplicity is desirable in order to relieve the need for a trained pilot and a high degree of coordination among the escape or rescue vehicle, lunar orbit space station, and Earth control center. The safety requirements are similar to the abort opportunities specified in the descent trajectories. To aid in meeting the simplicity requirements, it is desirable to keep the plane change small. This is, therefore, another reason for providing adequate surface survival time. Figure 5-16 shows a three-burn ascent which provides

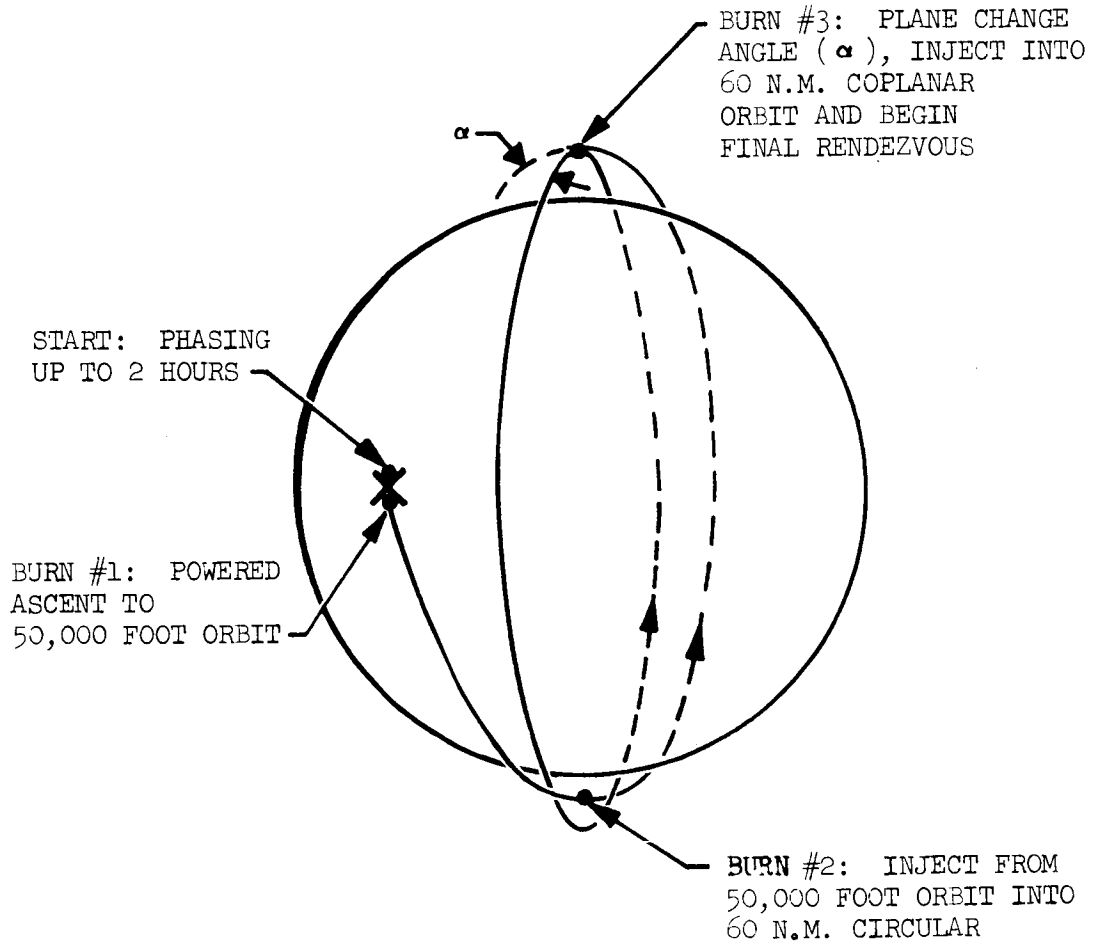

THREE-BURN ASCENT

TIME: 4.9 HOURS

ASCENT + COAST	.7
180 TRANSFER	1.0
RENDEZVOUS	1.2
PHASING (ON GROUND)	2.0
	<u>4.9</u>

Fig. 5-16 Three-Burn Ascent

for a plane change and circularization at 60 nm altitude. The advantage of injecting into a 50,000 foot altitude orbit at the end of a powered ascent is that a safe orbit is attained on one burn. The total ascent time, including orbit phasing on the ground and rendezvous is 4.9 hours. The ΔV required for a zero plane change ascent is about 6600 ft/sec.

A more elaborate method is available which places the vehicle in a high altitude apolune ellipse from the 50,000 foot orbit. In principle, this maneuver saves ΔV when a large plane change is involved. However, because the ascent will most likely be made with a small plane change, this added complexity is not justified.

5.3.4.3 Tug/Orbiting Lunar Station Rendezvous

The main requirements for rendezvous are the ΔV and a method for guiding the vehicle to a docking position that does not require a trained pilot and may be accomplished for all sun angles and lighting conditions. A ΔV of 150 ft/sec (included in 6690 ft/sec ascent ΔV) is sufficient for a co-planar rendezvous.

The guidance capability must be independent of pilot training because, in an escape, the trained pilots may be incapacitated. The above requirements also apply to the case in which the escape vehicle requires a rescue operation by a second rescue tug after injecting into orbit.

5.3.4.4 Transfer of Rescued Crew from Tug to Orbiting Station

The main requirement here is a capability of transferring incapacitated or injured crew members. The docking of the escape/rescue vehicle to the space station to provide transfer in the IVA mode is the best solution. The alternative method using the EVA mode may require the use of a pressurized stretcher. The latter should be available in the escape/rescue vehicle in case the transfer must be performed in the EVA mode. For the same reason, pressure suits and portable life support units should be available.

5.4 LUNAR SURFACE BASE ESCAPE/RESCUE CONCEPT TRADEOFFS

The purpose of the following analysis is to compare the advantages and disadvantages of the various concepts. Because rescue response times are in the order of hours, escape and survival concepts are considered first. However, the case of a completely incapacitated crew cannot be ignored and can only be remedied by use of an outside rescue team.

5.4.1 Escape from Lunar Surface Base

A parked tug is the basic escape vehicle for the crew if they have to abandon the surface base. The tug is parked a distance of 1 1/4 nm from the base to prevent damage to the base during landing and takeoff. Two methods are considered for traversing from the base to the parked tug; EVA rover and pressurized cabin rover.

5.4.1.1 Escape in the EVA Mode to Standby Tug

This concept depends upon the availability of a standby tug and the capability of at least two members of the crew to effect the transfer of personnel from the base to the escape tug, and to pilot it to orbit. The transfer of personnel may be accomplished by walking or riding a mobility vehicle. Of these vehicles, the rover is the most satisfactory because it can get close to both the base and the tug. Thus, walking distance is reduced to a minimum. More importantly, it reduces the distance that a pressurized stretcher must be carried. A handcart similar to the Apollo 14 type handcart could be provided which is capable of supporting a pressurized stretcher and being converted to a wheel chair for suited but incapacitated men.

Based on a 15 minute airlock cycle time, a 15 minute traverse time (1 1/4 nm) and that two capable crewmen are available, the time for a six-man crew to escape to the standby tug is 3.75 hours using a two man EVA rover and 3.0 hours using a three man EVA rover. For the two man rover, the one capable crewman with one incapacitated crewman cycles through the base airlock, traverses to the standby tug, cycles through the tug airlock, and returns to the base (one hour). In the meantime, the other capable crewman has cycled a second

incapacitated man through the base airlock to be loaded on the rover as soon as it returns. The complete evacuation requires nine $1\frac{1}{4}$ nm traverses including picking up the other capable crewman. Allowing three hours for denitrogenization, the total escape time after deciding to evacuate is 6.75 hours which is well within a 12 hour backpack time for the incapacitated crewmen. For the capable crewman the time margin of the backpack is dependent upon the amount of work required in transferring personnel. In the worst case, each man of a crew of two outputs about 1050 Btu per trip. This is based on metabolic rates of 700 and 1,400 Btu per hour for riding, and for handling a stretcher, respectively. If four incapacitated men are evacuated, the total work done per man is 4,150 Btu. Hence, a backpack unit have a capacity of 6,000 Btu gives a reasonable margin of safety. For a three-man EVA rover, two incapacitated crewmen are transferred at a time on the rover. This requires double cycling at the tug airlock by the capable crewman for a two-man capacity airlock, but the total traverses are reduced to five. Once all personnel are transferred to the parked lander tug, a surface waiting time of up to 14 days may be required before an ascent can be attempted. Hence, the parked tug should have an emergency surface survival time capability of 14 days.

5.4.1.2 Escape Via Pressurized Cabin Rover to a Standby Tug

The transfer of personnel in the IVA mode from the base to the tug eases the problem of handling incapacitated men in the EVA mode, and avoids dependency of the escape upon portable life support systems. The design penalties are associated with the docking of a cabin rover vehicle to the base and the lander tug. These docking ports could be surface-mounted. If elevated, the cabin rover could climb a ramp to mate with the docking ports, or may dock with a pressurized elevator compartment. The ramps and pressurized elevators are penalties to the lunar mission in that they are heavy and complex.

The cabin rover vehicle must have a docking port. If the docking ports on the base and tug are not on airlocks, the rover vehicle airlock must be capable of pressurizing itself to the base and tug 6.8 psia. This would enable the driver of the vehicle to stay in the vehicle throughout the

evacuation operation without decompression sickness, provided he were using an oxygen mask. This procedure would be equivalent to preoxygenating. The passengers would not be in the cabin rover long enough to experience decompression sickness.

Assuming a docking airlock cycle time of 15 minutes and a traverse time of 15 minutes each way (1 1/4 nm), the escape of a 6-man crew involving the transfer of four incapacitated men by two capable men will require a total time of 4.75 hours using a 2-man pressurized cabin rover. If a 3-man rover is used, the total time is reduced to 2.75 hours. Because the operation is in shirtsleeves, and all operations are sequential, one capable man could accomplish the transfer of the entire crew in the same times.

5.4.1.3 EVA Escape in LESS (Lunar Escape System)

LESS is a cabinless two-man flyer vehicle using a two- or three-step, bent ascent trajectory to a 60 nm orbit. It is manually controlled, and nominally seats two men in pressure suits. The ascent takes about ten minutes, and requires about 7,500 fps ΔV . A ΔV of less than 750 fps should be adequate for the orbital elements to rendezvous with the LESS. This is because the ascent and rendezvous will be nearly coplanar during the applicable situation.

The LESS vehicles may be stationed within a few hundred feet of the lander tug. The crew may walk from the tug to the LESS vehicles. Incapacitated men may be carried. The LESS vehicles may be fueled and essentially ready for takeoff. The feasibility of the concept depends upon the capability of the crew to manually control the LESS vehicle. At least one crew member per vehicle must be capable of piloting the LESS. The vehicle must be designed to carry an incapacitated individual, including a pressurized stretcher.

The concept is expensive because the LESS vehicle must be carried to the surface and several LESS vehicles would be required to return a base crew to orbit. Upon deactivation, the unused LESS vehicles would probably be abandoned. It is also considered hazardous and is not recommended.

5.4.2 Rescue from Lunar Orbit

In the category of rescue, the most general approach is that of surface rescue from lunar orbit. This concept requires that a lander tug always be on orbit at the station and on standby alert. A rescue crew must also be readily available. A second tug, as a minimum, must also be at the LSB during those periods of time that the base is manned. A third tug is then needed to perform landing sorties at remote sites or to perform orbital missions. Thus, a minimum of three tugs are required in the lunar area during the operational use of the base and station, and for other manned missions in orbit or on the surface.

5.4.2.1 Rescue Response Times

The nominal response times for a rescue from lunar orbit is given in Table 5-5.

The nominal response is defined as follows:

- There are no communication problems
- The decision to rescue is clear-cut
- The rescue tug and crew are available for immediate assignment
- The space station orbit plane is random with respect to the base
- The orbital phasing is random with respect to the base
- Two-man rescue crew
- Two-man airlock capacities

Nominal times are given for two landing distances ($1/2$ nm and $1\ 1/4$ nm) and two rover vehicles (2-man and 3-man). The total times are for transferring six incapacitated crewmen to the temporary safe haven of the rescue tug or the standby tug. In all but one case, the rescue time is less than the 12 hours survival time provided by a 6,000 Btu backpack for crewmen resting while awaiting rescue. It should be noted that the rescue crew will gain access to the base to render aid to the distressed crew in 8.1 hours which include bringing additional backpacks and/or suits depending on the status of the distressed crew.

Table 5-5
 NOMINAL RESPONSE TIMES FOR RESCUE BY CREW IN
 TUG FROM LUNAR ORBIT

Rescue Operation	Rescue Times (hours)			
	2-man Rover		3-man Rover	
	1/2 nm	1 1/4 nm	1/2 nm	1 1/4 nm
Rescue Alert to Separation From Station				
1. Rescue Alert Signaling			0.25	
2. Rescue Decision Making			0.25	
3. Tug Activation			1.00	
Separation to Touchdown				
4. Orbit Phasing			2.00	
5. Descent & Landing*			2.60	
Surface Operations				
6. Egress from Rescue Tug			0.25	
7. Deploy Rover			0.25	
8. Traverse to Distressed Vehicle	0.10	0.25	0.10	0.25
9. Ingress into Distressed Vehicle (Elapsed time until temporary aid available)	(8.10)	(8.35)	1.40	(8.10) (8.35)
10. Egress from distressed vehicle, traverse to return tug, load distressed crewmen	2.85	4.50	2.50	3.25
Totals	10.95	12.85	10.60	11.60

- Notes:
1. Tug carries either 2-man or 3-man rescue rover.
 2. Rescue rover one-way trip may be either 1/2 nm to rescue tug or 1 1/4 nm to standby tug.
 3. Crew of 6 to be rescued.
 4. Rescue Crew Size, 2.
- * 4-burn with flyover of base site.

A fast-response rescue is possible in the case of the rescue of a tug which fails at routine lift-off or landing. In this case, the space station orbit plane is approximately coincident with the base; the orbiting tug is in a dedicated, standby status; the space station orbital plane includes the base site at the time of surface lift-off or touchdown from orbit; and an investigation of conditions at the emergency site is not required. Under these conditions the rescue crew can reach the distressed tug in 2.6 hours including 2 hours for descent and 0.6 hours to unload and traverse to the distressed tug (1/2 nm).

5.4.2.2 Rescue Crew Pressure Suit Time Requirements

The total time span that the rescue crew must survive on portable life support systems is given below:

1/2 nm distance	-	3-man rover:	4.95 (hours)
1/2 nm distance	-	2-man rover:	5.3 (hours)
1 1/4 nm distance	-	3-man rover:	6.15 (hours)
1 1/4 nm distance	-	2-man rover:	7.4 (hours)

These times are all within the *8-hour nominal physical activity limit for a man in a space suit but will probably require changing backpacks.

5.4.2.3 Rescue ΔV Requirements

The penalty, in terms of ΔV , imposed by a rescue mission can be severe. The primary contribution (it should be recognized that the normal ascent/descent ΔV requirement is relatively fixed, and will be similar to the 13,990 ft/sec experienced on the Apollo program) to this penalty is derived from plane change requirements. In general, rescue vehicle plane change velocity can be expressed as a function of two operating modes (refer to Appendix A for a discussion of the velocity requirements for these two modes): (a) plane change accomplished at orbital altitude, and (b) plane change accomplished at apogee altitude of an elliptical orbit.

* See Bio Astronautics Data Book, NASA SP-3006, Paul Webb, M.D. Editor, 1964.

Note that no time limit is placed on an inactive crewman in a space suit, except availability of life support and power.

The rescue tug will, for a given configuration, have a specific velocity potential. The descent and ascent-to-orbit velocity requirements are relatively fixed. The remaining tug capability, if any, is available for accomplishing an orbit plane change during either descent or ascent, or both. After an orbital rescue tug has accomplished a landing at an emergency site, it is probable that the tug will have a very little ΔV capability available for a plane change.

The minimum remaining capability must be equal to, or greater than, that required for an in-plane ascent and rendezvous with the station. If the required ascent plane change and ascent ΔV requirements exceed the tug capability, it must remain on the surface until the Moon's orbital rotation reduces the required plane change to a level within the rescue tug's capability.

Table 5-4 presented typical ΔV rescue vehicle requirements for the two plane change modes. The choice between the two depends on the tradeoff advantage between ΔV needs and response time. For a 90° plane change at both descent and ascent, the table shows a ΔV savings of approximately 4,900 feet per second, if the plane change is made at apogee of a 24-hour period elliptical orbit. On the other hand, the elliptical orbit period represents the consequent cost in terms of increased response time (refer to Appendix A). Another approach to minimizing ascent rescue vehicle ΔV requirements calls for the rescue vehicle, after recovering and loading the stranded crew, to ascend and inject into a circular orbit on a trajectory that minimizes the orbit plane angle with respect to the station orbit. A vehicle in orbit, such as the PTV, another orbital tug, or even the station itself, would then make the required phase change and recover the crew and perhaps the rescue tug.

5.4.3 Lunar Surface Base Escape/Rescue Concept Conclusions

It is concluded that rescue capability using an orbital based rescue vehicle is required at all times. Therefore, one rescue tug should always be stationed in orbit. During tug landing and takeoff from the surface, the tug in orbit should be placed in a rescue alert, standby condition. A standby tug stationed at the lunar surface base at all times is advisable. The penalties of providing

for the IVA transfer of personnel between base and lander tug are sufficient to reject this plan for escape purposes.

An EVA rover vehicle must be carried by the rescue tug for surface transportation. The EVA rover vehicle must carry at least two men in suits, plus one man in a pressurized stretcher. The rover must operate at night and day.

The rescue tug must be capable of landing within 1/2 nm of the base under all lighting and night conditions.

Rescue and escape equipment should include the following:

1. Portable airlock
2. Handcart which can carry a pressurized stretcher, or serve as a wheel chair
3. Floodlights on the rover vehicle to light night operations during travel and ingress to the base
4. Tools to gain ingress to the base
5. Emergency power supply on rover vehicle to operate tools and elevators
6. Emergency communications equipment
7. Internal shelter in the base with 12 hour survival resources
8. A 6,000 Btu packpack with 12-hour battery life, for survival, escape, and rescue operations.
9. An EVA Rover, as described above.

5.5 LUNAR SURFACE BASE ESCAPE/RESCUE GUIDELINES

The following Escape/Rescue Guidelines are proposed for application at a lunar surface base.

1. Planned flights to and from the lunar surface base (LSB) should be made when the LSB surface site is in-plane with the station orbital plane.
2. An automatic (with manual override) rescue signal alert system is needed to transmit alarm signals to the Earth vicinity, orbital station, PTV, or other orbital elements. This system should be

- triggered by such items as: (a) unplanned depressurization, (b) base atmospheric contamination by toxic gases, (c) fire, (d) explosion, (e) bacteria, and (f) temperature extremes.
3. Provision must be made for a redundant, independently powered emergency communication with the Earth from a lunar surface base.
 4. The lunar surface base should be located on the Earth side of the Moon to ensure continuous communications with the Earth vicinity.
 5. Rescue operations in the near vicinity of a lunar surface base would be materially aided by the capability of direct unit-to-unit communications linked through the LSB as a repeater station.
 6. One or more lander tugs with crew-carrying capacity equal to the number of men in the lunar surface base area must be in a standby condition at the LSB at all times.
 7. The normal logistics vehicle landing site, and a backup site 1/2 nm (approximately) from the lunar surface base, must be marked with landing aids and equipped with location and tracking beacons to enable a landing at either site during day and night conditions.
 8. Any lander tug parked at the lunar surface base must have the life support capability to remain on the surface with a capacity load of escaped crewmen for a minimum of 14 days to ensure take-off conditions with no plane-change required.
 9. Emergency power and external control must be provided for any elevator or other means at the lunar surface base for ingress/egress into the LSB crew compartment.
 10. The lunar surface base airlocks should accommodate a minimum of two men in pressure suits or one man in a pressure suit and one man in a pressurized stretcher.
 11. An emergency internal communication system must be provided so that a rescue crewman can talk to stranded crewmen inside the lunar surface base regardless of the internal ambient atmospheric condition.
 12. At least one emergency sealed door is needed in the external shell of the lunar surface base. This door should be operable from either side and should be compatible with the portable airlock and sized to handle a pressurized stretcher and suited crewmen.

13. All airlocks should be equipped with power, controls, instrumentation and life support capability that is independent of the primary systems and operable regardless of the primary systems functional status.
14. Alternate compartments are needed in the lunar surface base to provide crew temporary safe havens. These compartments must be self-contained with respect to base subsystems. The minimum compartment life support capability span is forty-eight hours to enable rescue tug from orbit to complete a 90° plane change utilizing a 24-hour period elliptical orbit to minimize descent ΔV requirements.
15. The emergency gear carried by a rescue crew must include instrumentation for determining the base atmospheric composition including the level and type of any radiation that might be present. An external connector should be provided that ties into the base instrumentation system. An emergency backup system should be available at the vicinity of each airlock and emergency access hatch in case the primary instrumentation system has failed. Portable instruments should be carried by the rescue crew for use after access into the base has been obtained.
16. Emergency gear of the following types is required for use by the rescue crew for rescue operations at the lunar surface base:
 - (1) oxygen masks and portable oxygen supplies, (2) pressurized stretcher, (3) emergency pressure garments, (4) emergency communication gear, (5) portable airlock, (6) portable instrumentation, (7) cutting tools, (8) 3-man rover vehicle, and (9) first aid supplies.
17. The rescue tugs must be capable of completing rendezvous and docking with the orbiting lunar station regardless of orbital position and lighting conditions.
18. A rescue capability from orbit is required at all times that a crew is on the lunar surface.
19. An EVA rover vehicle with a 3-man capacity must be carried by the rescue tug from lunar orbit. The rover vehicle must carry at least two men in suits plus an incapacitated man in a pressurized stretcher.

20. The rescue tug must be capable of landing within 1/2 nm of a surface base under all lighting and night conditions.
21. Floodlights are needed on a rescue rover vehicle to provide light during night operations and ingress to the base.
22. A 6,000 Btu backpack with 12-hour battery life is required.

Section 6

LANDER TUG LOCAL OPERATION

The lunar lander tug will make individual landings at various lunar sites. These sorties will permit exploration of widely separated areas of the Moon, initially prior to establishment of the lunar surface base (LSB), but continuing throughout the lunar program. A typical sortie will be the landing of a single tug, with crew of four. The crew compartment may be elevated with the propulsion module below. The nominal mission duration will be up to 28 days. The site terrain may be somewhat rougher than that of the LSB, and landing aids will be minimal. Unlike the LSB, some sortie bases may be set up on the Moon's far side.

Unless special landing sensors are used, the planned tug landings will be made at optimum sun elevation angles using techniques similar to that of Apollo. Ascent and descent will be within the orbital station orbit plane with only small plane changes required.

For escape/rescue analysis the sortie consists of three operational phases:

- a. Landing and Activation
- b. Routine Operations
- c. Deactivation and Departure

A number of traverse operations may be performed. The escape/rescue requirements for these operations are discussed in Section 7.

6.1 ESCAPE/RESCUE SITUATIONS

The characteristics of the operational phase of the lander tug local operations and the significant hazards are shown in Table 4-3.

A hazard that is common to all phases of operations is that of injury to personnel. Four possible plans of action are considered.

1. The injured man is given medical care in the lander tug crew compartment. He is evacuated when the tug normally returns to orbit. This possibility is feasible depending on the nature of his injury. Injuries occurring during the initiation or routine phases are particularly hazardous because the surface crew will be short handed and may not be able to complete all assigned tasks.
2. The injured man may be returned to lunar orbit in an escape vehicle such as the Lunar Escape System (LESS). This approach is feasible if the ascent does not require piloting by the injured man, and if the escape vehicle environment is compatible with his injury, e.g., has a shirt-sleeve environment. If more than two men are injured, this mode of escape becomes impractical.
3. The tug mission may be terminated and the entire crew returned to the lunar orbit space station in the tug. This may require a large plane change.
4. A second lander tug may be sent down to pick up the injured man. This procedure requires that the rescue tug have a large plane change capability for both landing and return. If the capability limits the return to a small plane change, then the injured man will have to wait in the rescue tug. This option has an advantage over (1) above in that the injured man is replaced by a new crew member to carry on the lunar mission.

Of the four potential plans, 3 and 4 are the most general. Both pose large penalties to the lunar mission if they occur, but do not penalize the lunar mission if no emergency occurs. Plan 2 does penalize the lunar mission even in the absence of an emergency because of the weight of the escape vehicle carried to the surface. Plane 1 is always an available option, but should not be relied upon to solve the general case.

The communications failure hazard can be obviated by the carrying of emergency communications. In the event that the normal communications fail, the sortie crew may ask the space station to land a special communications package. This procedure would prevent the termination of the sortie because of inadequate communications. Such a device for deorbiting and landing an emergency package is discussed in Section 7 under the topic of survival kits. An automatic S.O.S. as discussed in Section 5.3 will be required to sound the alarm if all the sortie crew is incapacitated.

With regard to the landing and departure emergency situations, the men should be in pressure suits and on backpacks. Such is not the case during routine operations where the men may be in shirtsleeves at the time of the accident, which points out the need for an internal shelter for the incapacitated men in shirtsleeves. An external shelter may be (1) established as a routine safety operation, or (2) erected after the emergency as a temporary surface shelter. However, the use of this external shelter requires that some of the crew be able to don space suits, and to move the incapacitated men in pressurized stretchers to the external shelter.

The internal shelter may be a separate compartment or could even be one or more pressure garments. The pressurized stretchers and pressure garments may be similar. The addition of two rods or poles to the garment could convert it to a stretcher configuration.

6.2 ESCAPE/RESCUE CONCEPTS

The escape concept is that of employing the lander tug to ascend to the orbiting lunar station. The alternative escape concept of using a dedicated escape vehicle, such as a LESS, is rejected because of its lack of generality and its penalties to the lunar mission for routine operations.

The rescue concept is that of using a second tug from lunar orbit space station as a rescue vehicle. The escape requires that the return time must be short enough so as to be less than the survival time of a crew in space

suits and backpacks. This return response time requirements was not present in the case of the permanent surface base of Section 5. The reason is that the escape tug at the permanent base is not involved in the emergency at the base; therefore, it is available as a safe haven.

6.2.1 Escape

To meet the escape response time, the lander tug must have a 90-degree plane change capability so that the tug does not have to wait on the surface for an orbit plane reorientation with respect to the space station. The three-burn ascent of Figure 5-16 in Section 5.3 requires 4.9 hours. The transfer of personnel to the space station after docking should require less than an hour. The return response time is thus less than 6 hours, which is less than the nominal 8-hr physical activity limit in space suits. Thus, the safety margin is over 2 hours providing the 90° ascent capability exists. For a nominal tug with a total ΔV capability of 15,000 ft/sec, this will not be possible because some 7,300 ft/sec will have been used in the original descent. The ascent will require 6,690 ft/sec and a 90° plane change 7,500 ft/sec. Consequently, escape using the tug during routine sortie operations is not feasible except for those times when the plane of the orbiting lunar station is coincident with the lunar lander tug sortie site (once every 14 days). Therefore, rescue is the only practical plan to handle critical situations during a lunar lander tug sortie.

6.2.2 Rescue

The rescue from lunar orbit must be fast in those cases where: (1) the integrity of the crew compartment is violated, and (2) all or most of the crew is incapacitated so that they must survive on backpacks. The principal different assumptions between arrival/departure and routine operations are as follows:

1. For arrival/departure of the lunar lander tug, the emergency occurs during the planned landing or liftoff. Therefore, the orbiting station is passing over the landing site at about the same time. The landing site is essentially in the plane of the orbiting station's orbit. The communications

are satisfactory and a direct line-of-sight to the station is available. The rescue signaling and decision making can be accomplished in one quarter revolution of the station. At this point the rescue tug may make a slight plane change correction. At the end of another quarter revolution, the rescue tug makes a Hohmann transfer to 50,000 feet and initiates a power descent maneuver. The rescue vehicle has previously been readied for the possibility of rescue; it is manned, separated from the space station; the rescue crew is denitrogenized. Hence, the total time from rescue alert to landing is one orbit or 2.1 hours with the rescue crew ready to disembark.

2. For routine operations the station is in random phase and plane orientation with respect to the landing site. In addition, the rescue tug is not in a rescue mode, but is on normal standby. The descent trajectory is a four burn type with a flyover of the landing site to increase landing accuracy as was described in Section 5 for rescue of the lunar surface base crew by a tug from the orbiting space station.

The time from rescue alert to landing is 6.1 hours based on the following steps:

Rescue Alert Signaling	0.25 hours
Rescue Decision Making	0.25
Rescue Vehicle Activation	1.00
Orbit Phasing	2.00
Descent and Landing (4 burn descent with flyover)	2.60
	<hr/>
	6.1 hours

The assumptions common to both cases are as follows:

1. The disabled tug crew compartment is pressureless. Hence, the men may egress through an open airlock or an opened door.
2. The communications are adequate so that the nature of the emergency is understood by the rescue team.

3. A backside communications relay is available in support of any farside operations.
4. A two-man EVA rover vehicle is carried by the rescue tug.
5. The rescue tug lands 1/2 nm from the disabled tug.

Rescue crew egress, unloading the rover, traversing, and ingress into the disabled tug will take one hour if the tug is depressurized and an additional 1.15 hours if pressurized. Evacuation of 4 men to the rescue tug using a two man EVA rover will take 0.7 hour for 1/2 nm separation if the distressed crew are already in pressure suits and backpacks. If they are in shirtsleeves, they must be suited and cycled through airlocks on the distressed tug (may be a portable airlock) and the rescue tug which will remain pressurized to prevent decompression sickness of the distressed crewmen. This will require an additional 0.5 hour for the first and last cycle assuming the other distressed crewmen are cycled while the two man EVA rover is traversing back and forth (requires a 3 man rescue crew, one in rescue tug, one in distressed tug, and one driving).

The total rescue times are thus 3.8 hours for arrival/departure (distressed crewmen in pressure suits) rescue situations and 9.45 hours for rescue during routine operations if the distressed crew are in shirtsleeves in a pressurized lunar lander tug.

The crew survival time must be greater than 9.45 hours. This should be feasible with portable life support systems. A 6,000 Btu capacity backpack should last at least 12 hours when the men are resting (500 Btu hour). The battery life of the backpack would have to be compatible with this time duration.

A nominal rescue could be accomplished in a manner similar to that for the permanent surface base. Since the tug crew compartment is not pressureless, the ingress and egress procedures are similar to that for the base. The same requirements for information and special tools apply. The latter include

an emergency elevator power supply, rover vehicle equipped for night driving and lighting rescue operations, and pressurized stretchers. The temporary sortie base should install landing aids and a beacon during the deployment and activation phase. The survival time in the crew compartment or temporary surface shelter should be at least 12 hours. The rescue tug ΔV and survival time are the same as for the permanent surface base rescue.

6.3 ESCAPE/RESCUE GUIDELINES FOR LANDER TUG LOCAL SURFACE OPERATIONS

The following guidelines summarize the equipment and operational requirements for the escape and rescue of crews on the Moon's surface. The guidelines are keyed to major operational phases of the surface mission. Implicit in this summary is the selection of the most acceptable concepts as derived in the preceding analyses.

1. A minimum of one dedicated and serviced lunar lander tug must be docked at the orbiting lunar station at all times during a lander tug sortie operation.
2. A lander tug assigned to rescue in support of a lander tug sortie mission must have the capability to land at a planned site any time during the lunar day or night.
3. The lander tug used on sortie missions should contain pressure suits, backpacks, pressurized stretchers, and pressure bags or garments adequate to support the crew.
4. The lander tug should have a handcart capable of carrying a pressurized stretcher and crewman, or an incapacitated crewman in a pressure suit.
5. A rescue alert signal system is needed in the lander tugs that will automatically initiate a rescue needed signal based on sensed critical items such as hard landing, unplanned loss of crew compartment pressure, fire, explosion, or other situations with a high probability of crew incapacitation.
6. The lunar lander tug design should include at least one emergency access door that is compatible with the portable airlock design or could be used for egress/ingress when the tug is depressurized.

7. If the lunar lander tug design is such that the crew compartment is significantly above the lunar surface an elevator and emergency power supply are needed to enable a rescue crew to easily and quickly enter a disabled tug and remove incapacitated crewmen.
8. An uprated backpack is needed with a minimum metabolic capacity of 6,000 Btu's and a lifetime of at least 12 hours.
9. It is highly desirable that the lunar lander tug have a 15,000 ft/sec ΔV capability to ascend to orbital velocity, make up to a 90° plane change, and complete rendezvous and docking with the orbital station.
10. As an alternative or backup to guideline No. 9, the tug must have the life support capability to remain on the lunar surface until the ascent velocity (and plane change) requirements are within its performance limitations.
11. One of the first crew tasks, after a landing has been completed, is to deploy the rescue location aids. As a minimum these should include:
 - a. A tracking beacon for use by a rescue tug
 - b. Marker lights to designate the emergency landing site and desired touchdown point
 - c. A kit of rocket propelled rescue beacons
 - d. Emergency communication system
12. A lunar backside communications satellite is needed prior to initiation of surface landings on the backside.
13. The lander tug should have a capability for maintaining ambient atmospheric pressure about 3.5 psi. This capability could be in the form of a separate compartment or even emergency pressure garments.

Section 7

LUNAR SURFACE TRAVERSE OPERATIONS

The traverse operations take place in the vicinity of, or between, the permanent and temporary lunar surface bases. The traverse may be made by the crews on foot with and without a handcart, or in an EVA mobility vehicle, or by using a flying vehicle, or in a pressurized cabin mobility vehicle. The objectives of these traverses include the following: to permit the crew to explore the lunar surface, perform experiments, set up instruments, transport cargo and/or crew, and construct base facilities.

Table 4-4 lists a number of proposed mobility vehicles. Range in the table is defined as the total distance that the vehicle can travel without refueling.

The EVA vehicles operate relatively close to a parked tug and/or a lunar base. The separation distance of base and vehicle should never be more than the distance that the vehicle can travel in one-half the operating time of the EVA life support equipment.

The cabin rover vehicle may travel between two widely separated points on the Moon. The sortie base tug from which it originates may return to orbit after the rover vehicle reaches its point of no return, and the pick-up tug may not land until the rover vehicle nears its destination.

7.1 TRAVERSE ESCAPE/RESCUE SITUATIONS

In this section the EVA escape/rescue situations are defined for walking and vehicular traverses. The pressurized cabin rover escape/rescue situations are then described. The major difference between the two types of traverses is the range requirement.

7.1.1 EVA Traverse Escape/Rescue Situations

A critical factor during EVA traverses is the condition of the pressure space suits and portable life support systems. A torn suit would require immediate remedy. For tears on the suit limbs, automatic, expanding, sealing diaphragms are a possibility. Effects of small punctures may be temporarily modified by increased pumping by the backpack until a patch or pressure garment can be donned. In the event of damage to the space suit or backpack, the capability of the individual to walk back or drive back is entirely or severely impaired.

7.1.1.1 Walking Traverses

The maximum walking range is determined by the capacity of the portable life support system. The average metabolic rate during walking is 1,400 BTU/hour, and a man can walk about 2.16 knots (4 km/hour). A residual in the backpack amounting to 20 minutes upon return is a nominal requirement. Hence, the walking ranges are nominally 6.7 and 8.5 nm for the 4,800 and 6,000 BTU backpack units, respectively. The maximum distance from a base will be one-half these ranges. The time-distance envelope for a walking traverse is shown in Figure 7-1 for a man with a 6,000 BTU unit. The envelope is based on walking to a given distance and performing science activity until the backpack residuals require that the man turn back. The metabolic rate of performing science activity is 1,100 BTU/hour.

7.1.1.2 EVA Rover Vehicle Traverses

Figure 7-2 shows a time-distance envelope for an EVA rover vehicle. The crew rides out to a given distance at 4 knots. The maximum range of the rover vehicle is 16 nm. The metabolic input to the suit is 700 BTU/hour when the men are riding; when not riding, the men are engaged in science activity. Two backpacks are furnished each man. The ground rules require that 20 minutes of life support residuals be available upon return, and that the total physically active time in suit should not exceed 8 hours. The men switch their backpacks at the dashed turnback line in Figure 7-2. This line is chosen such that the men can ride back to the base using the first backpack if they

6000 BTU BACKPACK
1400 BTU/HR WALKING
1100 BTU/HR NORMAL SCIENCE
EXPERIMENT ACTIVITIES
2.16 KNOTS WALKBACK

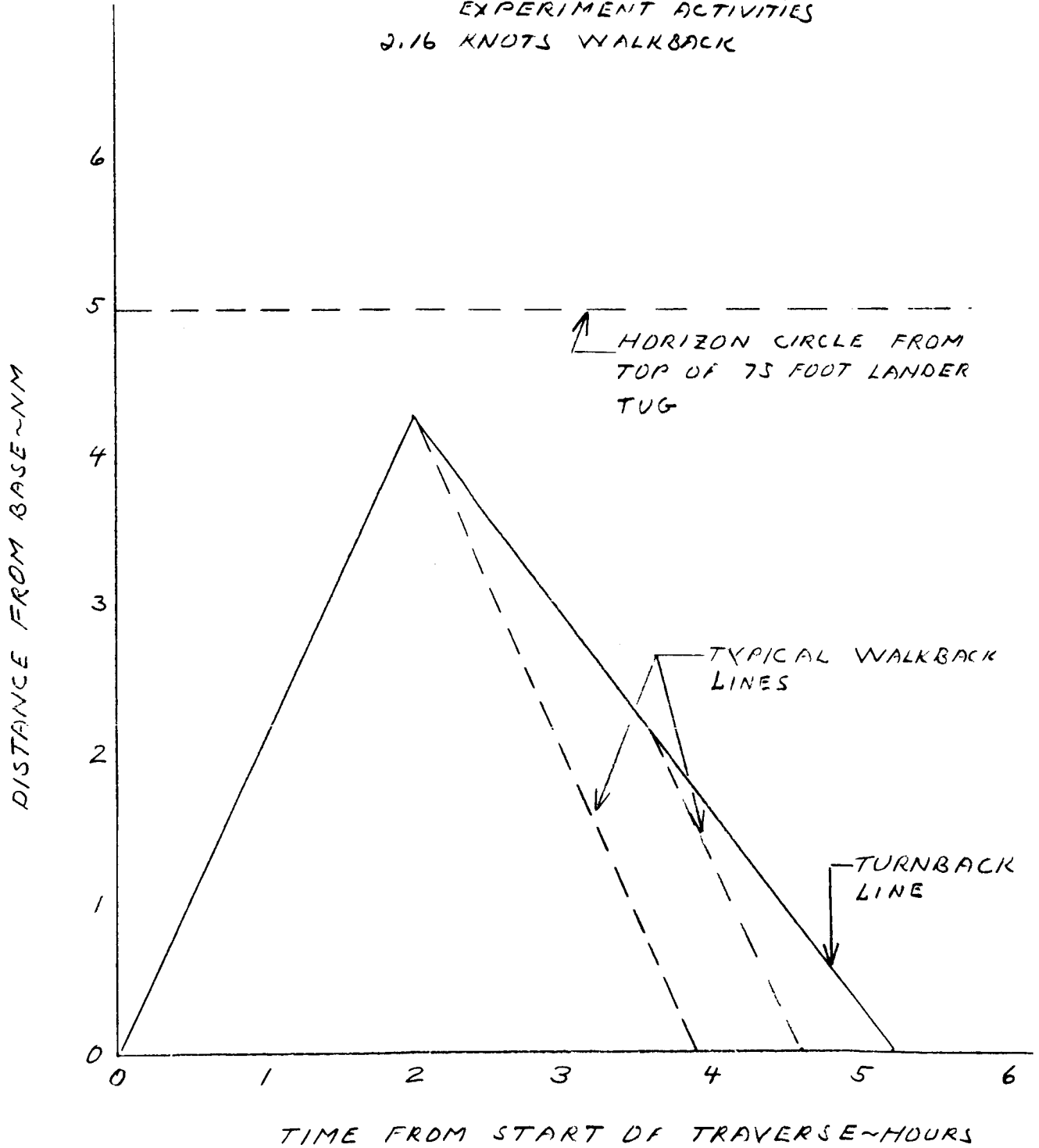

Fig. 7-1 Envelope of Walking Traverses

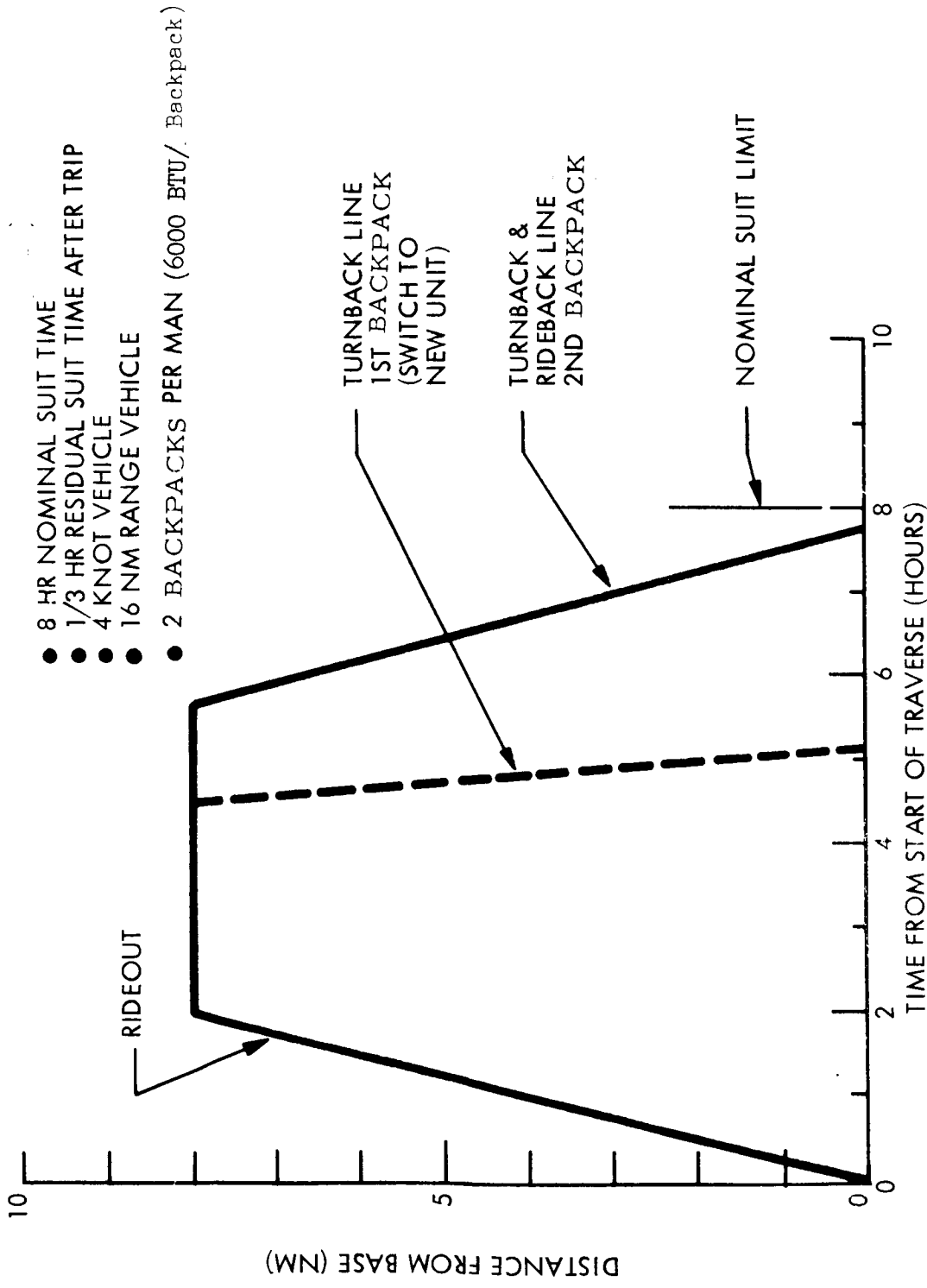

Fig. 7-2 EVA Rover Vehicle Traverse Envelope

cannot switch to the second unit. If the switch is accomplished, the men will turn back at the solid line in the figure. This turnback line is the same as the ride back because the men are not limited by the backpacks, but rather by the 8 hour physical activity time limit in space suits. In the above analysis, it is assumed that a technique of switching a suit from one backpack to another in a vacuum environment has been satisfactorily developed.

Walkback capability has not been used as a criterion for establishing the rover traverse envelope. Such a criterion would severely limit the usefulness of the EVA rover vehicles.

In case rescue is necessary, the rescue party may be uncertain as to the location of the rover vehicle and its crew, especially if communications are disrupted. The men on Apollo traverses are required to report in at least every 5 minutes. Under this circumstance, the maximum distance that the rover vehicle could travel is $1/3$ nm or 2,000 feet. There will be some uncertainty in the location because of the navigation of the rover vehicle. Assuming a gyro compass with a $1/2^{\circ}$ /hour drift rate, the maximum error in 8 nm is about ± 840 feet, assuming a 2 hour travel time. Hence, the position of the vehicle would be somewhere in an error footprint about 4,000 feet long and 1,700 feet wide.

7.1.1.3 Lunar Flyer Traverses

The lunar flyer will probably be used to deploy scientific payloads at various points of interest around the lunar surface base or an isolated lunar landing tug. The advantage of the flyer is that it can quickly travel to distant points, ascend to high altitude points, and cover rugged terrain as is shown in Figure 7-3. A flight time of only two minutes is required for a 5 nm journey. A small lunar flyer could have a range of 10 nm and carry one man. An uprated flyer may carry two men and have as much as a 30 nm range.

A typical mission takes about 3 hours. Of this time, about $1\frac{1}{2}$ hours are spent away from the vicinity of the base. The other $1\frac{1}{2}$ hours are divided between the preparation for flight and the post flight activity at the base.

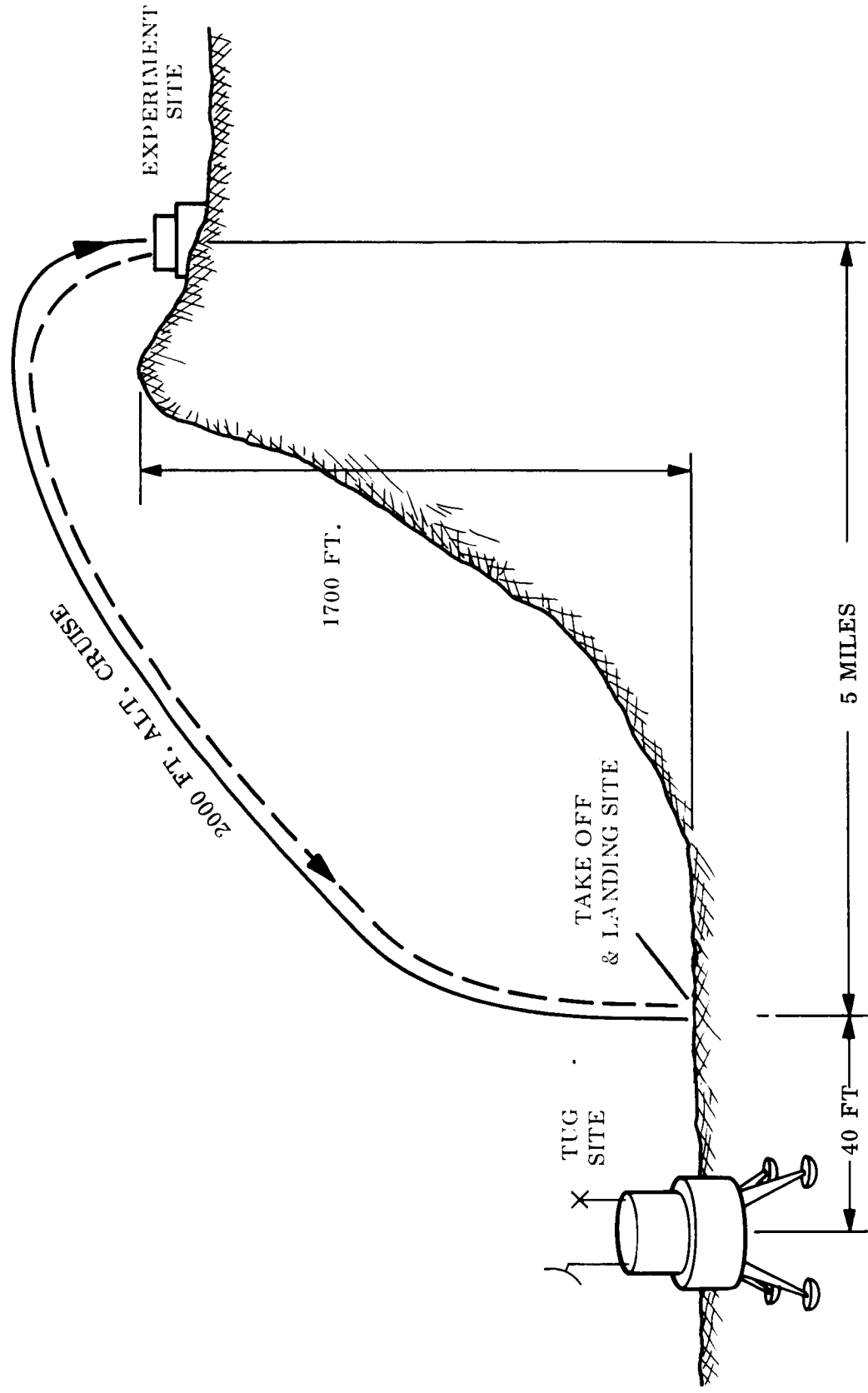

Fig. 7-3 Typical Lunar Flyer Mission

The science time is sufficient to deploy an experiment, collect a soil sample, or check an instrument that has been posted earlier. In any case, the flyer mission will most likely be arranged to return the astronaut(s) well before their nominal suit time has elapsed, or before their backpack resources have been exhausted. If an extra backpack or an emergency life support system is provided, the crew survival time is lengthened accordingly. The envelope of the lunar flyer traverses are shown in Figure 7-4.

The position of uncertainty of the flyer is dependent upon the type of emergency encountered. The following are believed to be possibilities.

1. After landing, the lunar flyer cannot be restarted. In this case, the position uncertainty is small because the landing site has been pre-selected.
2. The flyer is forced to land somewhere between the base and one of the landing sites. Since the crew reports to the base at each landing site, the last landing site and the next landing site will be known to the base personnel. The flyer will be somewhere between the two sites. If no communications are available, the base personnel will only know the line along which the flyer may be located, and the limits of this segment. In the case where the flyer visits one landing site at the maximum one-way range, the position uncertainty along the straight line flight path is equal to the one-way range. If two sites are to be visited, the maximum position uncertainty will be about one-third the total range of the vehicle.
3. The flyer may overshoot a landing site. This may occur, for example, because the attitude hold circuit will not decouple from the pitch servo network. Hence, when the pilot attempts to pitch the vehicle in order to decelerate the flyer horizontally, the control system realigns the thrust vector vertically. After the pilot recognizes the problem he may disconnect the control system, throttle back and attempt to land under manual control. Assuming the pilot response is 15 seconds, the vehicle, traveling at 180 knots, may overshoot as much as 4,500 feet.

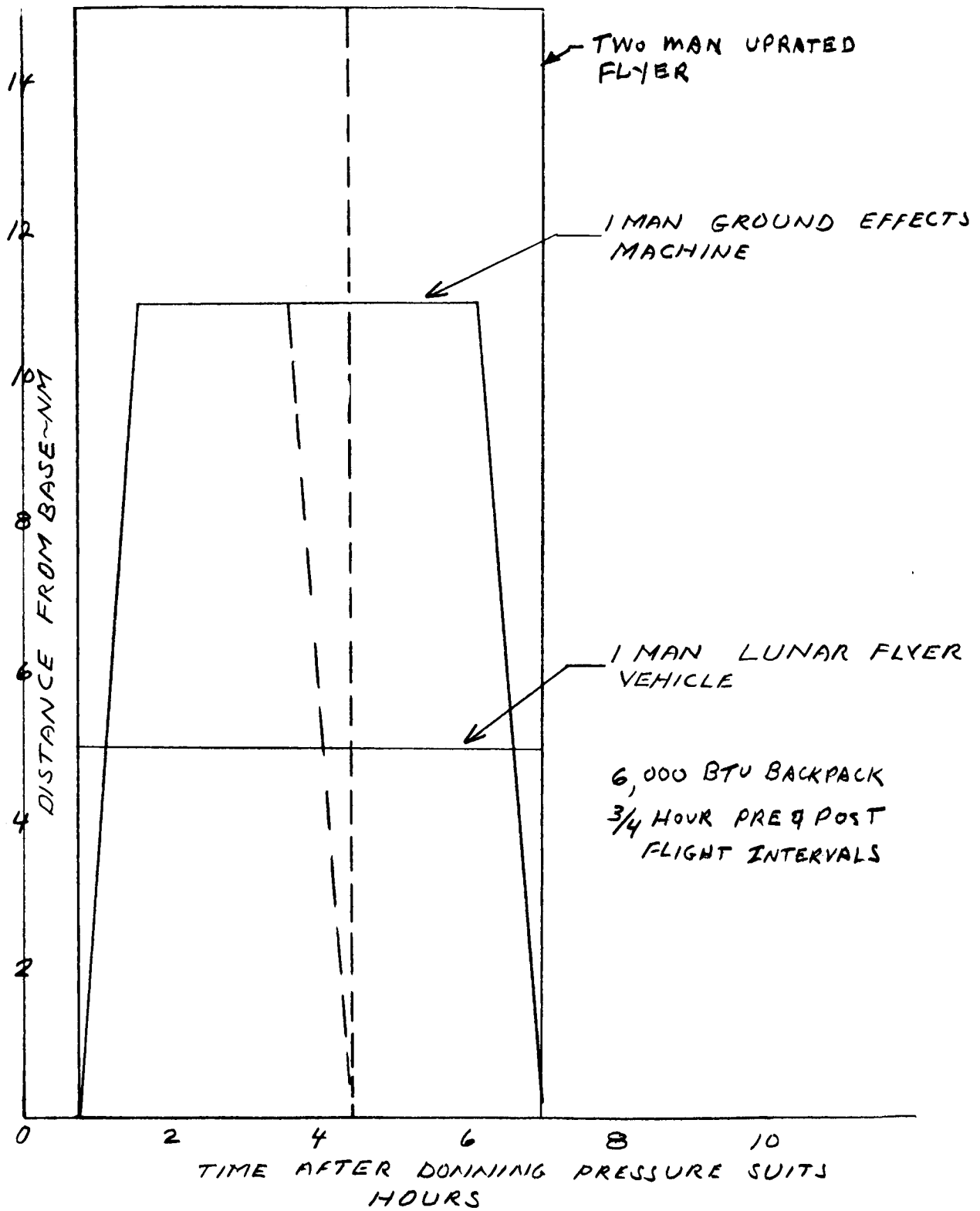

Fig. 7-4 Lunar Flyer and Ground Effects Machine Traverse Envelopes

It is emphasized that the rescue of the flyer may be complicated by the fact that the landing sites selected for the flyer may be in rugged uplands, or inside craters.

7.1.1.4 Ground Effects Machine Traverses

The ground effects machine may be used in the scientific exploration of the Moon to reduce the time to visit test locations. It can be used in a manner similar to that of the lunar flyer, except that the flight path must pass over less rugged terrain. One man may be carried as far as 11 nm from the base. The average velocity (with stops) is 14 knots. Return is planned to meet the backpack and suit limitations. The distance-time envelopes are shown in Figure 7-4. The location error in event of an emergency is probably restricted to the distance between preselected stopping sites. Since the vehicle will probably stop often, the position uncertainty should be no more than about 1.5 nm.

7.1.1.5 EVA Traverse Rescue Requirements

The rescue plan must cope with the situations summarized in Table 7-1 in terms of crew size, terrain features, and position uncertainties. The distance-time envelopes established the possible events at which an emergency may occur. The lighting conditions at the time of a traverse and rescue will probably be daylight. However, some science work could be done during the night considering that both the permanent and temporary bases will be on the lunar surface during the night. The night distance-time traverse envelopes may be restricted to within line-of-sight of the lander tug or lunar surface base. The horizon circle of a 75-foot high tug or base is about 5 nm.

7.1.2 Pressurized Cabin Rover Vehicle Traverses

Failure of the communications, mobility, or life support functions are situations to which a cabin rover vehicle may be exposed. In addition to the communications and mobility functions, there is the cabin life support function which may be impaired. The proposed cabin rover has 7 days of life support

Table 7-1 EVA TRAVERSE RESCUE SITUATIONS

VEHICLE	CREW	TERRAIN LIMITS	POSITION UNCERTAINTY
ROVER	2	SMOOTH, GENTLE SLOPES	1700 FT X 4000 FT (5 MINUTE REPORTING PERIOD)
FLYER	1	ELEVATED LOCATIONS, SEVERE SLOPES	0-5 NM ALONG TRAVERSE PATH 4500 FT OVERSHOOT OF LANDING SITE
UPRATED FLYER	2	ELEVATED LOCATIONS, SEVERE SLOPES	0-15 NM ALONG TRAVERSE PATH 4500 FT OVERSHOOT OF LANDING SITE
GROUND EFFECTS MACHINE	1	SMOOTH TO ROUGH, GENTLE SLOPES	0-1.4 NM ALONG TRAVERSE PATH

under emergency conditions. This means that the emergency power is sufficient to maintain life support functions while the vehicle is stationary for a minimum of 7 days.

The accidents which may befall a cabin rover are characterized by the condition of its mobility and the integrity of the pressurized compartment. If the latter is violated, the crew must survive on their portable life support systems. When the pressurized compartment is intact, the crew can survive a minimum of 7 days. The latter is based on an emergency system where the rover vehicle is stopped and all non-essential gear is turned off. If neither the pressurized compartment nor the mobility fails, the crew may have problems if their communications systems fail. In this case, the crew must decide whether to drive on to the appointed base, return to the starting point, or wait for rescue. Hence, while a driveback capability exists, it may be extremely risky to employ it, especially if the rover vehicle is near the middle of a one-way traverse.

A position uncertainty of less than 3 miles is predicated upon a reporting period of 30 minutes. If driveback is attempted without communications, this uncertainty would be increased. Rescue may be required to take place at night for long traverses.

Two types of traverse are apparent. The first traverse consists of a closed path that starts and ends at the lunar surface base or a parked lunar lander tug. The second traverse is an open ended path which ends at a base or tug other than the one at the starting point. In the latter case, the tug at the starting point may re-orbit after the cabin rover has passed the point of no return. In addition, the terminal tug could delay landing until the cabin rover nears its destination.

The maximum range and the stay times are shown in Figure 7-5 for two versions of the cabin rover. The small rover, plus payload but minus crew, weighs about 6,000 lb. Typical recurring nonscientific operations requirements in man hours per day for a two man crew are as follows:

Range vs. Staytime

- Limited by maximum expendables capacity
- No experiment power included
- Manned vehicles provide additional 7 days emergency layover
- Speed 10 kph for 2 men, 5 kph for 1 man, 2 kph unmanned

VEHICLE -01

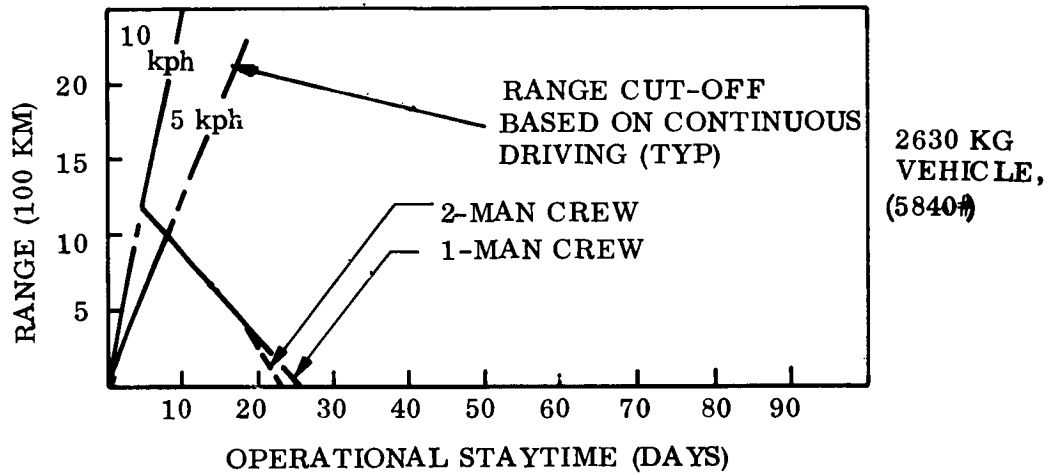

VEHICLE -02

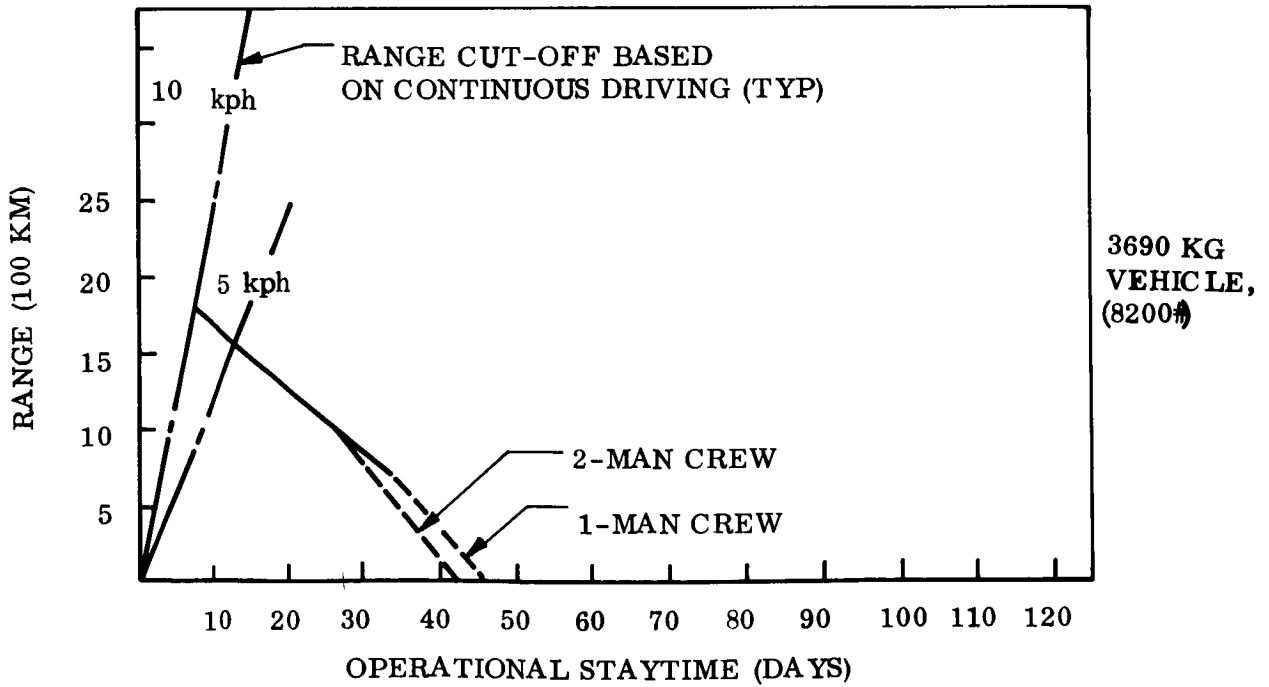

Fig. 7-5 Cabin Rover Traverse Envelopes

	<u>Shirtsleeve</u>	<u>Pressure Suited</u>
Housekeeping and Maintenance	5	0.5
Crew Rest	16	-
Crew Personal Activity	8	-
Airlock Operations (1.5 cycles per man day)	2.4	1.2
	—	—
Total Man Hours/Day	31.4	1.7

This total amounts to about 69% of the crew's time. The crew may perform scientific activity to the extent of the capacity of a pressure suit and backpack, that is, one sortie per day.

At an average rate of 1,100 Btu/hour for scientific activity, the 4,800 Btu unit would be good for 4-1/3 hours, and the 6,000 Btu unit good for about 5-1/2 hours. Considering all things, we can therefore anticipate that EVA scientific activity will be limited to 5 hours per man at the maximum. This amounts to about 20% of the crew's time. The balance could be used in driving a vehicle, or about 11% of a day.

Figure 7-6 shows the percentage time required for driving to cover the range along the abscissa of the curve. These data are derived from Figure 7-5 using a speed of 5.4 knots (10 km per hour) and a crew of two men. If the driving time is to be about 11%, the maximum range of the two vehicles are about 250 and 410 nm, for the small and large cabin rovers, respectively. Hence, the maximum distances from the base will be 125 and 200 nm for the respective rover vehicles in a return route path. These distances are also the points of no return for the two vehicles in an open ended, non-return, path.

The maximum distance from base to a large cabin rover vehicle in a circular traverse of 400 nm length is $400/\pi = 127$ nm.

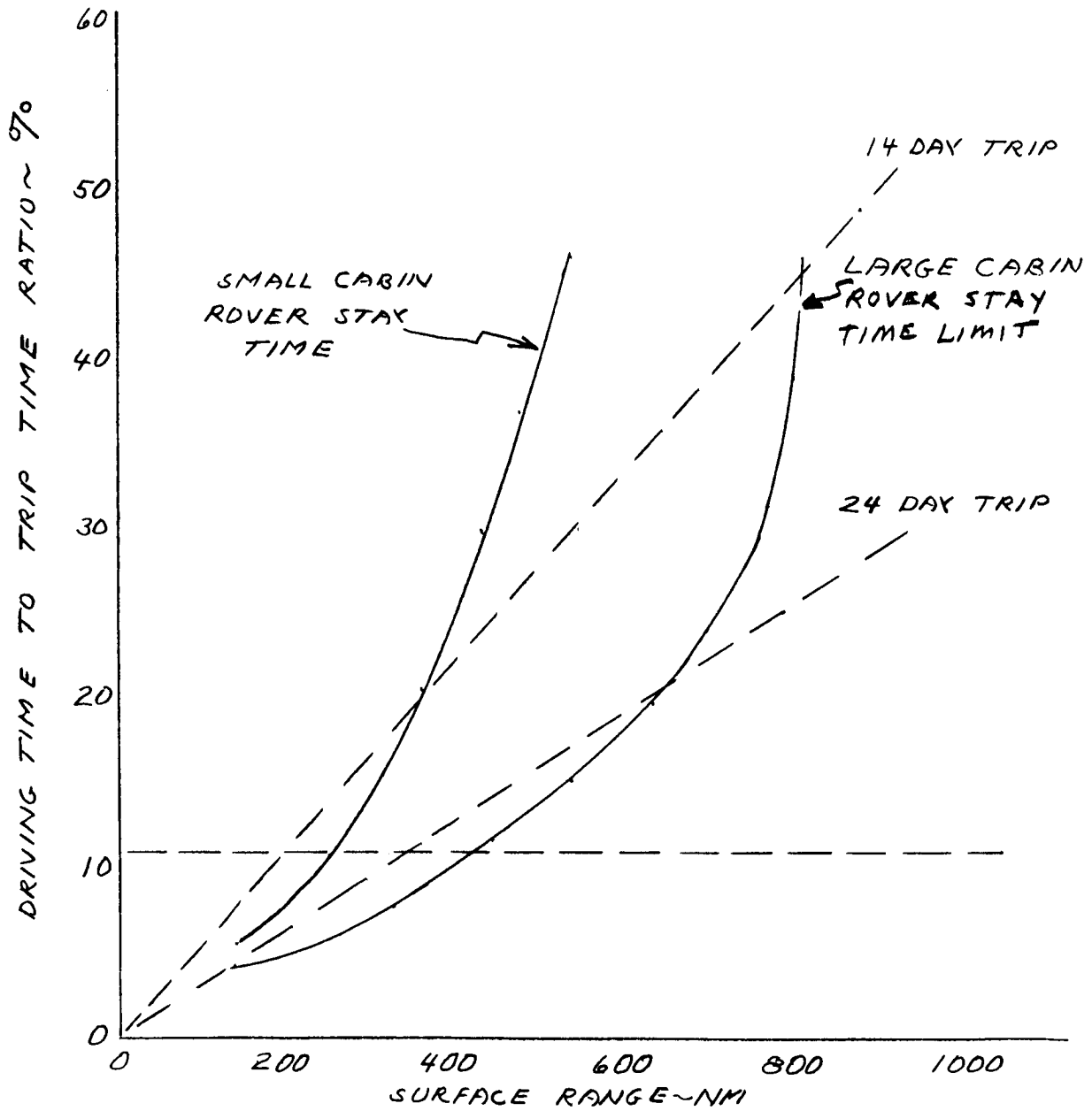

Fig. 7-6 Driving Time as a Percentage of Total Trip Time Vs Cabin Rover Range 5.4 Knot (10 km/hr) Speed Crew of Two

In case the rover vehicles become immobile, the minimum survival time is 7 days. This assumes that the pressurized compartment is not damaged. If the integrity of the pressurized compartment is violated, the theoretical survival time will depend upon the backpack units available. Assuming that one unit is available per man, the survival time is 9.6 to 12 hours depending on whether the 4,800 or 6,000 Btu units are available. These data assume that battery life is not a limiting factor, and that the man output an average of 500 Btu/hour at rest. The driveback range using one backpack is 38 and 46 nm for the 4,800 and 6,000 Btu units, respectively. These data are based on a 700 Btu/hour metabolic rate for driving the rover vehicle and a vehicle speed of 10 km/hour (5.4 knots).

The emergency may occur in the daylight on a 14 day or shorter duration traverse. Where survival times are short because the integrity of the pressurized cabin has been violated, the rescue would therefore be made in the daylight. Where the cabin is intact, the survival time is at least 7 days so that the actual rescue could take place at nighttime if the emergency took place after the first half of the trip. On longer duration traverses, night rescue may be required.

The position of the cabin rover on a traverse as known by the rescue crew is a function of the communications check-in cycle, the speed of the vehicle, and the navigation of the rover crew. The rover vehicle will probably be equipped for voice communications directly with the Earth and the lunar orbit space station when the latter is in line-of-sight. PCM telemetry television and scientific data will probably also be transmitted. Assuming that the rover vehicle checks in every 1/2 hour, the maximum position uncertainty would be $1/2 \text{ hour} \times 5.4 \text{ knots} = 2.7 \text{ nm}$ plus the navigation errors. If the vehicle checked in only before and after a traverse, the position uncertainty might be $11\% \times 24 \text{ hours} \times 5.4 \text{ knots} = 14 \text{ nm}$. This would occur if the communications failed at the end of the driving period. In general, the crew would not deliberately move the vehicle if they knew that the communications were out. Hence, a sensor that indicated whether the communications were viable might be helpful in reducing position uncertainty.

The position errors at check-in may be those associated with navigation using heading and velocity techniques, updating techniques, or the sighting on a known lunar landmark. A recent study shows that a hand held space sextant gives an error of 1,700 feet or 0.28 nm. If the position is computed from a directional gyro and odometer, the maximum error after 4 hours and 5.4 knots travel will be about 0.1 nm. This is based on a 700 feet odometer error, and a maximum 2° heading error.

Hence, if the communications are lost, the position uncertainty is 2.7 nm based on a 1/2 hour check-in period. If communications are not lost, the rover crew can identify their position within 0.28 nm.

7.2 TRAVERSE ESCAPE/RESCUE CONCEPTS AND ANALYSIS

Table 7-2 presents some possible approaches to the escape/rescue of crews on traverses. Each approach is analyzed as it applies to the traverse indicated by the X's.

7.2.1 Walkback Escape/Rescue Concept

Walkback from the scene of an emergency is practical if (1) the personnel are not injured, (2) the backpack capacity is adequate, and (3) if the physiological limit of the suited man is not exceeded. Figure 7-7 shows the walkback limit superimposed on the EVA vehicular traverses. The limits are based on an eight-hour physical exertion limit. It is apparent that walkback does not offer a general procedure even if all the above conditions are met.

In the case of foot traverse, the men could take a handcart (similar to the one used on Apollo 14) with them. An extra backpack may be carried along to replace a damaged backpack so that walkback is possible. A survival bag may be carried to encase the man if he tears his suit. In this latter case, he would have to wait for rescue.

The emergency garment concept is a temporary, individual shelter that must be portable so that it can be placed on the EVA rover vehicle or passed through an airlock of the pressurized cabin rover vehicle. It might be converted to a pressurized stretcher if designed for lifting poles or rods to be attached.

7.2.2 Escape/Rescue Rover Vehicle from Base

A rover vehicle can be used to make a surface rescue of men on foot, in EVA rover vehicles, and on flyers whose locations are accessible. Pressurized cabin rovers have the advantage of bringing a shirtsleeves environment to the disabled crew. This means that the survival time of the disabled crew in their space suits or emergency garments is minimized. The range of the EVA rover vehicle will probably be less than that of an uprated flyer or ground effects machine.

Table 7-2
LUNAR TRAVERSE RESCUE/ESCAPE APPROACHES

CONCEPT	EVA TRAVERSES					CABIN TRAVERSES	
	On Foot	Rover Vehicle	Flyer	Up-rated Flyer	Ground Effects Machine	Vehicle Immobile	Pressure Compartment Integrity Violated
1. WALKBACK	X	X	X				
2. ROVER VEHICLE FROM BASE	X	X	X	X	X		
3. LESS/FLYER FROM BASE	X	X	X	X	X	X	X
4. LUNAR LANDER TUG FROM SURFACE				X	X	X	X
5. LUNAR LANDER TUG FROM ORBIT				X	X	X	X
6. PORTABLE EMERGENCY ESCAPE SYSTEMS				X	X	X	X
7. SURVIVAL PACKAGE DROPS FROM ORBIT				X			X
8. BUDDY VEHICLES		X	X	X	X	X	X

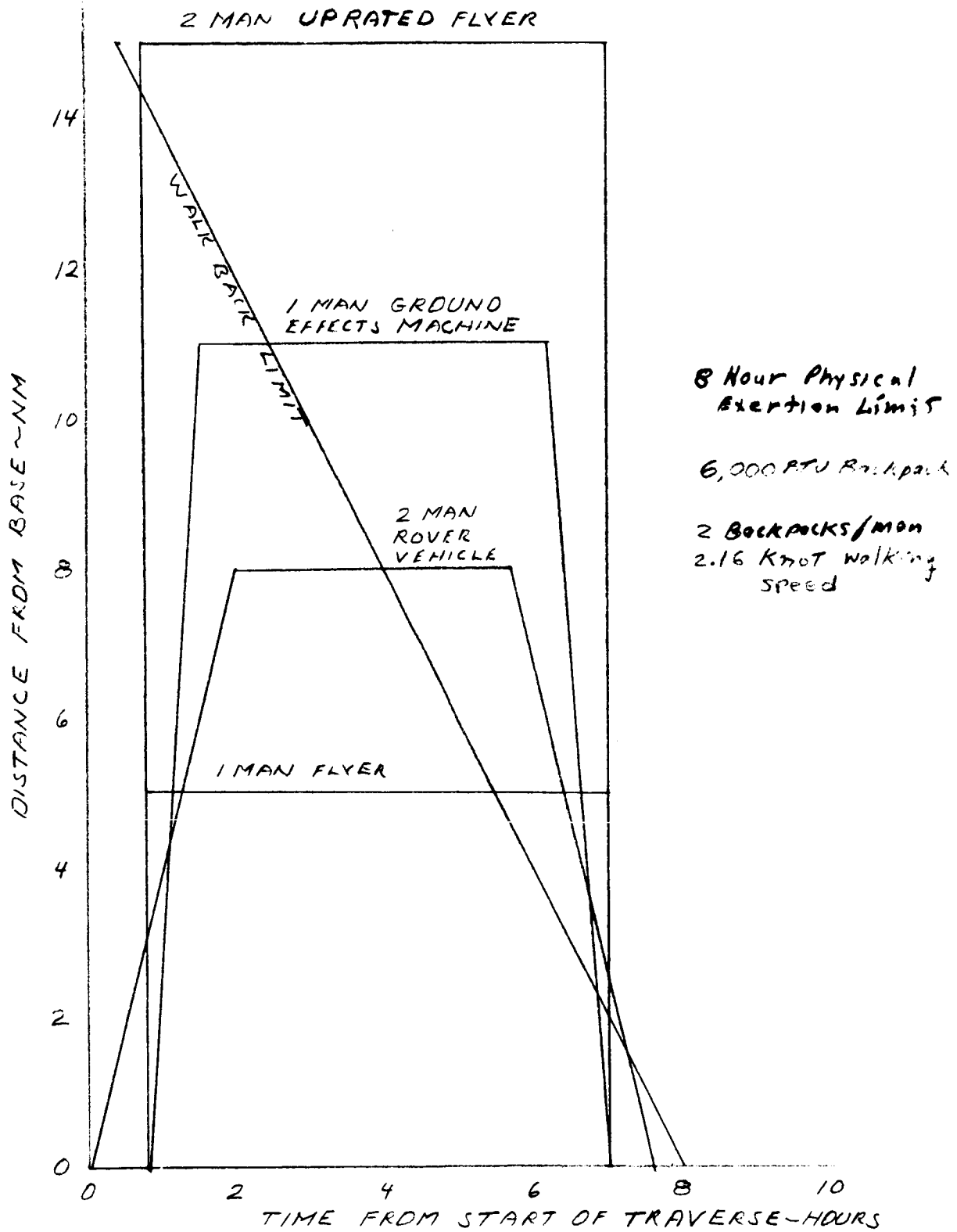

Fig. 7-7 Walkback Limits Superimposed on EVA Vehicle Traverse Envelopes

The response time of a rover vehicle for rescue is $T = t_c + t_p + d/V$ where t_c is the communications and rescue decision time, t_p is the time for the rescue personnel to be suited and in the rover vehicle, d is the distance to the emergency site, and V is the average velocity of the rescue rover.

The value of t_c ranges from virtually zero to the time period of the check-in cycle. A nominal value of the latter is five minutes. Some values of t_p are tabulated below:

Condition	t_p (Minutes)
Remote guidance of rover to rescue site (activate guidance system)	5
Manual guidance of EVA rover vehicle	
Driver in base denitrogenized	20
Driver in base not denitrogenized	200

The denitrogenization is assumed to require three hours. Ten minutes is allowed for egress from base, and a similar amount of time for ingress or mounting the rover vehicle.

Remote guidance may extend beyond the horizon circle of the base because Earth or the lunar orbit space station may control the vehicle. Farside operation will be possible if a farside communications relay is available.

The velocity of the vehicle depends upon the terrain to be traversed. The following engineering estimates of vehicle speeds are presented.

Terrain Features	Speed in Knots	
	Four Wheel Vehicle	Six Wheel Vehicle
Maria	3	4
Uplands	1.7	3
Uplands Assumed Average	.9	1.5

Table 7-3 gives the response times of four and six wheel vehicles assuming the above performance, a maximum distance from base and the percentage of uplands travel shown in the table. The data can be interpreted as survival time

Table 7-3
 RESCUE TIME OF ROVER VEHICLES FOR EVA TRAVERSES
 (HOURS)

Distressed Crew Situation	On Foot 1-2 Men	EVA Rover Vehicle 2 Men in	Flyer 1 Man on	Ground Effects Machine 1 Man on	Uprated Flyer 2 Men on
Distressed Crew Location (NM)	4.25 nm	8 nm	5 nm	11 nm	15 nm
% Uplands Travel to Distressed Crew	0	20	80	40	60
Rescue Time with Remote Guidance for Rescue Rover					
4 Wheel Vehicle	1.6 hr	4.1 hr	4.9 hr	7.3 hr	12.2 hr
6 Wheel Vehicle	1.2	2.8	3.1	4.8	8.4
Rescue Time with Manual Guidance for Rescue Rover					
Driver Denitrogenized or in Cabin Rover					
4 Wheel Vehicle	1.9 hr	4.4 hr	5.2 hr	7.6 hr	12.5 hr
6 Wheel Vehicle	1.5	3.1	3.4	5.1	8.7
EVA Rover with Driver Not Denitrogenized					
4 Wheel Vehicle	4.9 hr	7.4 hr	8.2 hr	10.6 hr	15.5 hr
6 Wheel Vehicle	4.5	6.1	6.4	8.1	11.7

requirements of the disabled crew in their EVA accoutrements. The response times for the manual guidance, and driver not denitrogenized, are used because:

1. The remote guidance mode is not applicable to situations in which only one man is on traverse. The remote guidance rescue does not provide a man to help an injured person or one who is encapsulated in a survival bag.
2. In the general case, the rescue crew will be in the base and not denitrogenized. An exception which rules out the need for immediate denitrogenization is where a cabin rover vehicle is docked to the base.

The comparison of the survival time requirements for rescue with the survival capabilities shows which rover vehicles are generally applicable to a rescue. The survival time for men on traverse can be established at 12 hours by providing a spare 6000 BTU backpack for each crewman. A six-hour survival time could be provided two men on a walking traverse where only one emergency unit was used on a buddy system. These survival times (12 hours for vehicle traverses and 6 hours for walking traverses) are adequate for all EVA rescue situations given in Table 7-3 except for using a 4-wheel rover to rescue the crew of an uprated flyer. The use of the EVA rover (either 4 or 6 wheel) for the rescue of a crew of a Ground Effects Machine or an uprated flyer is not applicable in the general case because of range limitations (refer to Table 7-1).

The general conclusion is that the rescue by rover vehicles is sensitive to the duration between the base and the crew on traverse. The particular conclusions are as follows:

1. The 6 wheel pressurized rover vehicle is a versatile rescue vehicle.
2. An emergency 6000 BTU backpack for each crewman is required to enable a rescue by a rover vehicle.
3. In the case of a damaged suit, some type of pressure garment must be provided which can utilize the residual backpack capability.
4. The rover vehicles should be capable of carrying one-to-three men.
5. The rover rescue vehicle must be equipped with a means of picking up a man in a pressure garment.
6. A remotely guided rover rescue vehicle is not a general rescue vehicle.

7.2.3 Rescue Flyer from Base

In principle, the lunar flyer vehicle (LFV) or the lunar emergency escape system (LESS) can be used to rescue men on traverses. The two vehicles are similar except that the LESS is designed mainly to lift men from the surface to orbit. It may, however, be used as a constant altitude flyer (LESS/Flyer). The advantage of LFV and LESS/Flyer are their response time, and their capability to fly over rough terrain. The disadvantages are their altitude, speed, and controllability as it affects the search capability, and the required landing distance to the disabled vehicle because of the dust cloud.

7.2.3.1 Response Time for Rescue Flyer

The response time of the LFV or LESS/Flyer as a rescue vehicle is determined mainly by the activation time of the rescue crew. This is because the flight time constitutes only a small portion of the time to rescue. As was pointed out in the discussion of the rover vehicles, the activation of the rescue crew may be three hours for denitrogenation. The checkout and balancing of the vehicle requires five to ten minutes; fueling, if required, may take 30 minutes. Typical flight times are $2\frac{1}{2}$, $3\frac{1}{2}$, and 7 minutes for 5, 10, and 30 n.m. distances, respectively. The greatest times required to get to the scene of an emergency are 3.7 and 3.9 hours for ranges up to 30 n.m. The return trip requires, say, 30 to 45 minutes for loading and balancing the flyer for a return trip. These response times meet all EVA traverse requirements. They are adequate for cabin rover traverse situations provided that the range of the flyer is satisfactory.

7.2.3.2 Range for Rescue Flyer

The range of the uprated LFV is 30 n.m. The radius of a round trip for the LESS/Flyer is given in Figure 7-8. In this figure, the dry weight and payload of the LESS/Flyer is held constant and the propellant is varied. LESS/Flyer designs of 60 n.m. round trip ranges have been proposed. Ranges in excess of this amount will probably entail design penalties.

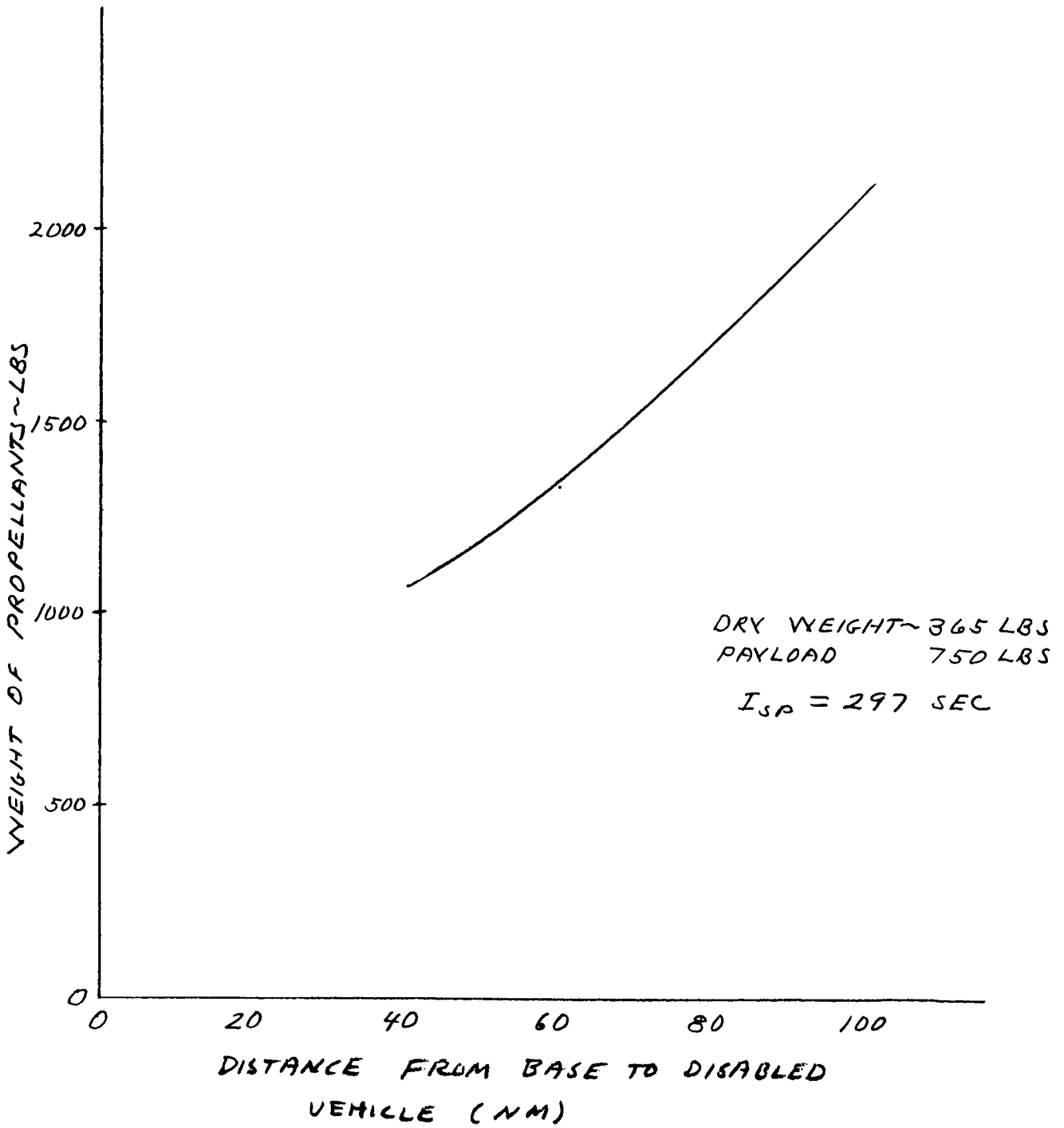

Fig. 7-8 Propellant Requirements vs. LESS/Flyer Round Trip Radius

The LESS/Flyer must have a minimum radius of 200 n.m. to accommodate the cabin rover open-ended traverses. This is the midpoint of a 400 n.m. traverse. A radius of 127 n.m. is needed to accommodate a 400 n.m. circular traverse by the cabin rover.

The conclusion is that current flyer and LESS/Flyer preliminary designs are adequate for all EVA traverses, but that additional range is needed to rescue a crew on a long distance cabin rover traverse.

Minimum ranges of the flyers may prevent them from rescuing crews on foot traverses.

The LFV and LESS/Flyer meet the requirements of traversing rough terrain to rescue the flyer, updated flyer, and ground effects machine.

7.2.3.3 Payload Capacity of Rescue Flyer

The capacity of the one-man flyer is one man plus 400 pounds cargo. If the cargo facilities can be modified to carry a passenger, the one man flyer may be used to rescue another one-man flyer. Similarly, the updated two man flyer has the payload capacity to carry three men. Hence, the updated flyer can rescue all EVA traverses. The LESS/Flyer seats two men and has an additional payload capability equivalent to the weight of two more men. The problem is to convert the cargo mass carrying capability to passenger carrying capability. Balancing of crew and cargo is a requirement for flight. The cargo platforms are generally fore and aft with the engine in the center. A three or four seat design, where the two seats can fold down to accommodate pressurized stretchers, appears to be the most desirable. The balancing of the vehicle will be a problem with the current design approaches.

7.2.3.4 Search Capabilities from a Rescue Flyer

Another requirement for the flyer is to search for the disabled vehicle while in flight. The requirements were given in Table 7-2. The speed, altitude, and attitude of the flyer vehicle during the approach to the search area are

factors in a successful search, The time available to the rescue crew to visually scan the lunar surface is also a factor in search.

In order for the flyer to slow down, it must rotate its thrust towards the landing site.

Table 7-4 shows the surface range to the landing site at which slowdown begins, and, hence, when the thrust vector must be rotated. These data assume a thrust to weight ratio of 1.4 during slowdown, and a pitch angle of 45° . The distance is computed from the formula

$$\Delta s = \frac{1}{2} \frac{V^2}{g_m}$$

where V is the cruise velocity, and g_m is the lunar gravitational acceleration (5.31 ft/sec^2). The time to slowdown, without hovering, is V/g_m . A greater pitchover angle (from vertical) will reduce the slowdown distance and time but will reduce the region of pilot vision even more.

Table 7-4

FLYER CHARACTERISTICS

Flyer Range (NM)	Optimum Cruise Speed (fps)	Slowdown Initiation	
		Distance from Landing Site (NM)	Time-to-go (Minutes)
5	300	1.4	1
10	425	3.8	1.6
30	750	8.7	2.4
60	1040	15.5	3.1

The data shows that either search must occur during slowdown, or the search must be successfully completed before slowdown begins. Two search situations are apparent.

1. For the EVA rover, cabin rover, and ground effects machine, the rescue search area is localized. The rescue flyer may aim at the center of the uncertainty area and make flight corrections during slowdown provided that the search is successful. For the longer range flights, the data shows that it is problematical that the disabled vehicle can be seen before slowdown is initiated. Hence, search again occurs during slowdown.
2. For the rescue of a crew of a one-man flyer or an uprated flyer, the search area extends along the whole path of the traverse. Hence, the search must determine the location of the disabled vehicle before slowdown if the disabled vehicle is not down at its furthest traverse point. The search may have to be successful as much as four miles ahead of the rescue flyer. In addition, the search may also have to occur during slowdown if the disabled vehicle is at its maximum traverse distance. Thus, in the case of the rescue of another flyer, two situations arise: Search before slowdown and search during slowdown.

The requirements for a search during slowdown are considered first. One flyer design approach is to reorient with a fixed engine. This would prevent the rescue crew from seeing the search area. The rescue flyer must, therefore, have a movable engine or platform, and stability control, to facilitate the search during slowdown.

Another factor in the search during slowdown is also common to the search before slowdown. That is the ability of the rescue crew to concentrate on the searching operation. A completely manual stabilization system leaves the pilot concentrating on the horizon, sun, or some lunar landmark. If the rescue crew consists of one man only, there will be little time for him to perform the search operation. Thus, stability control is highly desirable for the rescue flyer, and a must where the flyer is passenger limited.

In the case of search before slowdown, the cruise speed of the flyer should be reduced to give the searcher the most time. The small flyer's speed of 300 fps (180 knots) seems acceptable. Lowering the longer range flyer's optimum speed of 500 fps to 300 fps will entail a penalty of about 500 fps in the characteristic velocity. This penalty does not appear significant in using the long range LESS/Flyer for a short range rescue.

Search before slowdown may be obviated or helped by the proper employment of communications. Every reasonable effort should be made to include an automatic radio location beacon on the disabled vehicle. This beacon would reveal the range and azimuth of the disabled vehicle. A lunar rocket rescue beacon, sighted before the rescue flyer started on its mission, would give the location of the disabled vehicle so that search before slowdown would be obviated. The ranging and azimuth accuracies for the radio beacon and the lunar rocket beacon would be about 1600 ft and 0.115° , respectively. The latter amounts to an accuracy of 1200 and 2400 feet for ranges of 10 and 20 nm, respectively.

7.2.3.5 Landing Distance for a Rescue Flyer

The final factor in the use of a flyer for a rescue mission is the closeness with which the flyer can land to the disabled vehicle. The distance will depend upon the terrain features and the accuracy of the landing. The latter is affected by the dust cloud created by the rocket engine. In addition, it will not be good practice to subject the disabled vehicle and crew to a shower of particles. If the last ten seconds of landing is blind, a distance of 70 feet would be required. This is based on the maximum of 7 fps horizontal landing speed. Probably the miss distance will be on the order of one-to-two hundred feet.

This distance will be greater than the requirements in many cases. If the crew of the disabled vehicle are injured, or in pressure garments, the rescue craft should be in close proximity of the disabled craft. Otherwise, the loading of the injured crew on the rescue vehicle will require two rescue crewmen to carry stretchers. An alternative may be to carry a wheeled stretcher, or handcart, on the rescue vehicle. A one man rescue crew could possibly transport an injured man in this manner.

7.2.3.6 Conclusions Regarding a Rescue Flyer

The general conclusion regarding flyers as a rescue vehicle is as follows: They avoid the sensitivity of the rescue mission to the emergency life support requirements of the crew on traverse, but require several design features to make them practical as a rescue vehicle. These required design features are given below:

1. One way ranges up to 200 n.m. are needed to rescue a cabin rover crew.
2. The rescue flyer must have a gimbaled engine or platform.
3. The flyer should have stability control.
4. The flyer should carry a minimum of three men.
5. Two seats must be adaptable to carry pressurized stretchers.
6. Beacon ranging and azimuth instrumentation should be installed on the flyer.
7. A wheeled stretcher cart should be carried on the rescue flyer as standard equipment.
8. The cargo capacity of the flyer on the outbound leg of the mission should be used to carry special gear as required by the situation, such as tools to get inside a wrecked cabin rover.

The search for a downed flyer vehicle is facilitated if the crew of the disabled vehicle can fire several rocket beacons before the rescue flyer starts out to insure receipt of rescue alert and to facilitate location determination.

7.2.4 Lunar Lander Tug for Rescue from Surface

The lunar lander tug could fly to the disabled surface vehicle using a ballistic trajectory. Figure 7-9 shows the theoretical ΔV required to take off and land. Subsequent to the pickup, the tug could go into lunar orbit with the rescued crew. A 200 n.m. surface range, needed for a cabin rover rescue, appears to be feasible.

The concept is rejected, however, primarily because it exposes the rescue crew to a hazard upon landing. Failure of the engine to restart will cause a crash landing.

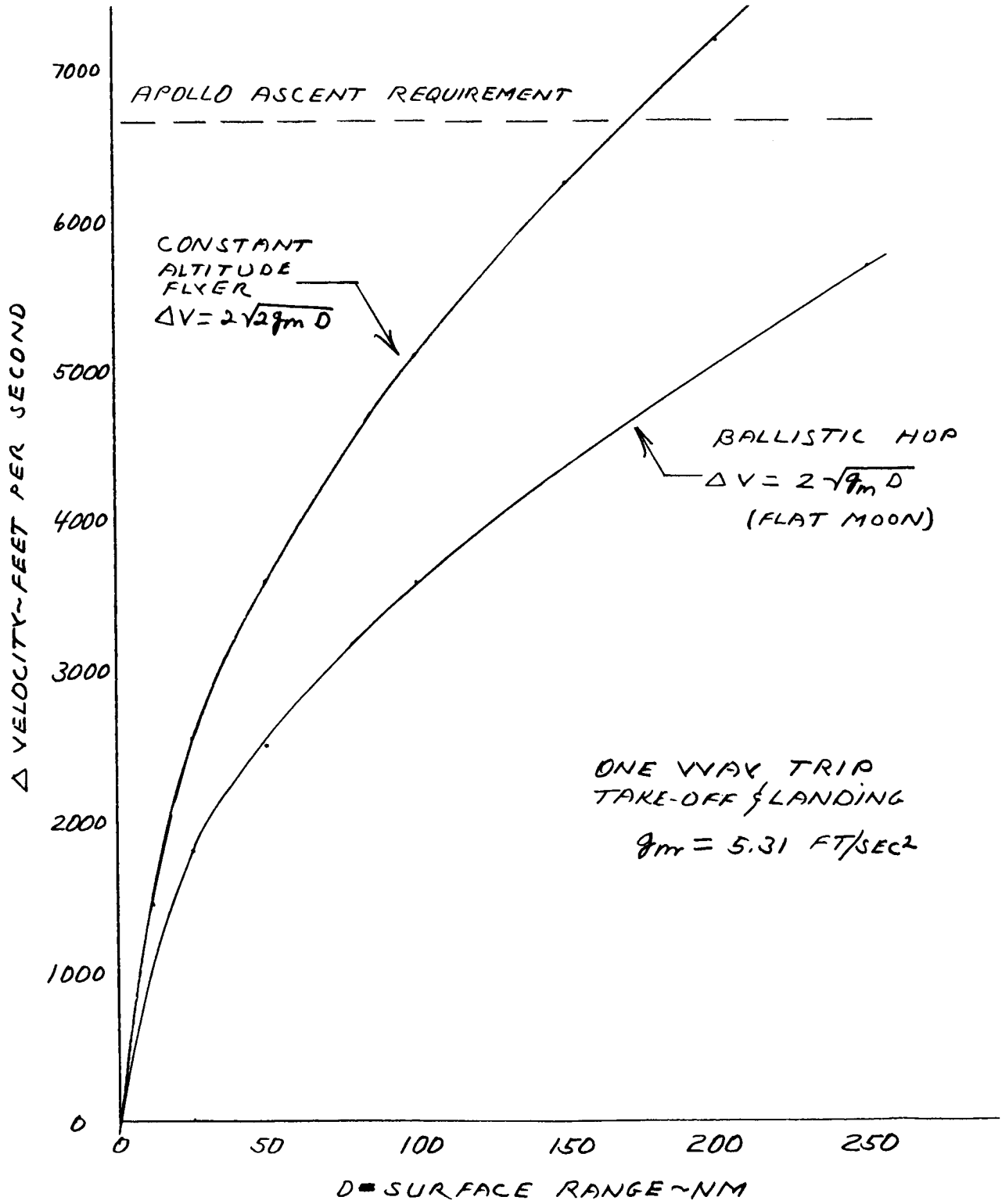

Fig. 7-9 Ballistic Hop Surface-to-Surface Velocity Requirements

As an alternative, the lander tug could (1) fly to the site of the emergency in a manner similar to that of the lunar flyer or LESS/Flyer, or (2) ascent on a short arc and inject into a 10 n.m. orbit followed by a powered descent to the landing site. Both methods offer more safety than the ballistic trajectory. The ΔV requirements for flying at constant altitude and at optimum velocity is shown in Figure 7-9. These requirements are theoretical. The theoretical requirements for the second case are equal to the potential energy in ascending to 10 n.m. plus the orbital velocity of 5500 fps. These requirements are twice 6300 fps or 12,600 fps.

The flyer mode ΔV requirements are less than the 12,600 ft/sec required for orbiting, up to a range of about 600 n.m. Since the cabin rover traverse will be less than this, there is no need to use the orbiting method.

The tug will be unable to land close to the disabled vehicle because of the dust cloud and surface ejecta that it raises during descent. Hence, a second step in the rescue is required to get the rescue crew to the disabled vehicle after the tug lands.

The advantages of using the tug as a flyer are (1) the response time is satisfactory, (2) the size of the rescue crew is not limited to one or two men, (3) the crew compartment provides a shirtsleeves environment, safe haven for the rescued personnel, and (4) a potentially large payload capability is available for carrying emergency gear.

The response time is about $4\frac{1}{2}$ hours, allowing $\frac{1}{2}$ hour for signaling and decision making, three hours for the rescue crew to denitrogenize during which interval the tug is activated and flown to the site of the emergency, $\frac{1}{4}$ hour for egress of rescue crew, $\frac{1}{4}$ hour for unloading an EVA rover, and $\frac{1}{2}$ hour to locate and travel to the disabled vehicle.

The design penalties for adding a flyer capability to the tug may be substantial because (1) a means of increasing the field of vision for the pilot must be provided, and (2) the stabilization system requirements may be severe.

7.2.5 Lunar Lander Tug for Rescue from Orbit

The lunar lander tug in a lunar orbit offers an approach to the rescue of personnel on traverse. The approach is not general, however, for the following reasons:

1. The lander tug cannot land in rough terrain to rescue a lunar flyer.
2. The lander tug will have difficulty in searching for a disabled vehicle if the latter is without an active beacon.

In both of these cases, the rescue would have to be performed in two steps. The first step would be to land the tug from orbit. The second step would involve the use of a mobility vehicle to search for the disabled vehicle and/or rendezvous with it. For the rescue of personnel on EVA traverses, there would be little advantage in landing a tug from orbit over mounting a rescue from the lunar base or a tug on sortie which is in the vicinity of the disabled traverse vehicle.

The rescue of the personnel in a cabin rover traverse is a potential application of the tug from orbit. The procedure would be essentially the same as rescue of a lunar surface base crew (Section 5.4.2) or a lunar lander tug crew (Section 6). In the previous cases 1.4 hours was allowed for ingress by the rescue crew which is a long time for a pressurized cabin rover. However, this time should be allowed for search and traverse to the cabin rover. Consequently, the time required to reach the distressed crew of a pressurized cabin rover by a lunar tug from the orbiting space station is 8.1 hours (Table 5-7). The response time of the tug from orbit is competitive with a cabin rover vehicle in those situations where the distance between base and disabled cabin rover is more than 32 nm. The ΔV requirements are similar to those of Section 5.4.2 for the rescue of personnel in a base. The design penalties are the same as those for other surface rescue missions performed by a tug from orbit with the possible addition of a beacon tracking system. The tug will be required to carry an EVA rover vehicle. The tug will not be able to land immediately adjacent to the disabled vehicle because of the dust cloud and surface ejecta problems.

In the situation of an open ended cabin rover traverse, the following operational procedure should be of advantage. In the open ended traverse, the cabin rover vehicle departs from the lunar surface base, travels two to four hundred nautical miles, and meets a tug on sortie for pickup. The pickup tug should remain on orbit until the cabin rover vehicle nears the rendezvous point, say within an EVA traverse range of eight miles. This procedure allows the tug on orbit to rescue the cabin rover if the latter gets into trouble before it completes its traverse.

7.2.6 Portable Emergency Escape Systems

In this concept, a cabin rover vehicle carries or tows an escape vehicle during its journey. The escape vehicle may have a surface-to-surface or a surface-to-orbit capability. Candidate escape concepts are as follows:

1. Surface-to-Surface
 - a. Two one-man or one two-man POGO type flying vehicles can be used for surface-to-surface transportation. The current design weighs 147 pounds without fuel or men, and is $22\frac{1}{2}$ inches wide, $45\frac{1}{2}$ inches long, and about 5 feet high. A hydrogen peroxide propulsion system has a thrust level of 600 pounds for 21 seconds flight time. A lunar version could use nitrogen tetroxide and an equal blend of hydrazine and unsymmetrical dimethyl hydrazine for propulsion. Its flight time could be extended to 14 minutes or more. The range will probably be less than that of the Lunar-Flyer or LESS/Flyer.
 - b. An uprated Lunar Flyer Vehicle can also be used for surface-to-surface transportation up to about 30 nm range with two men.
 - c. The LESS/Flyer is capable of flying up to 200 nm range with two men.
2. Surface-to-Orbit
 - a. The LESS may fly to orbit with two men.

- b. Two one-man Lunar Escape Ambulance Packs (LEAP) can carry the men to lunar orbit for pickup by an orbiting space tug. The vehicle could carry an incapacitated man in a pressurized stretcher. The operation and control of the vehicle is automatic during ascent, and is controlled by the space tug during rendezvous.

7.2.6.1 Surface-to-Surface Concepts

The surface-to-surface concepts must have one-way ranges of 127 nm to accommodate a large circular traverse with a cabin rover and 200 nm for an open-ended traverse. Using the data of Figure 7-8, we can construct the graph of Figure 7-10. In this figure, the weight of a two-man flyer vehicle is plotted against the total one-way range of the vehicle. The two-man Uprated Lunar Flyer falls on this curve if part of the payload (other than passengers) is converted to propellant. It is assumed that POGO also follows this trend.

For a 200 nm return range, the weight of the flyer vehicle and propellant is about 2,540 lb. This weight penalty, if carried or towed by a large cabin rover, will increase the power requirements by roughly a factor of 1.25 if the velocity is to remain the same. The response time, in returning to base, would be well within the life of a PLSS unit.

The POGO vehicle's range is too short to be used with a cabin rover. Assuming that it has a 16 nm one-way range, it would be satisfactory for all EVA traverses. A two-man POGO will weigh about 460 lb per Figure 7-10. An Uprated Lunar Flyer may carry this amount of payload. The one-man Lunar Flyer and ground effects machine appear capable of carrying a one-man POGO. Hence, it is feasible for these vehicles to carry an escape vehicle. The disadvantage of this procedure is that it displaces the scientific payload that could be carried by the flyers or ground effects machine.

The EVA rover vehicle could carry or tow a two-man POGO with an increase of vehicle power by a factor of about 1.35 for the small EVA rover, and 1.25 for the large EVA rover vehicle.

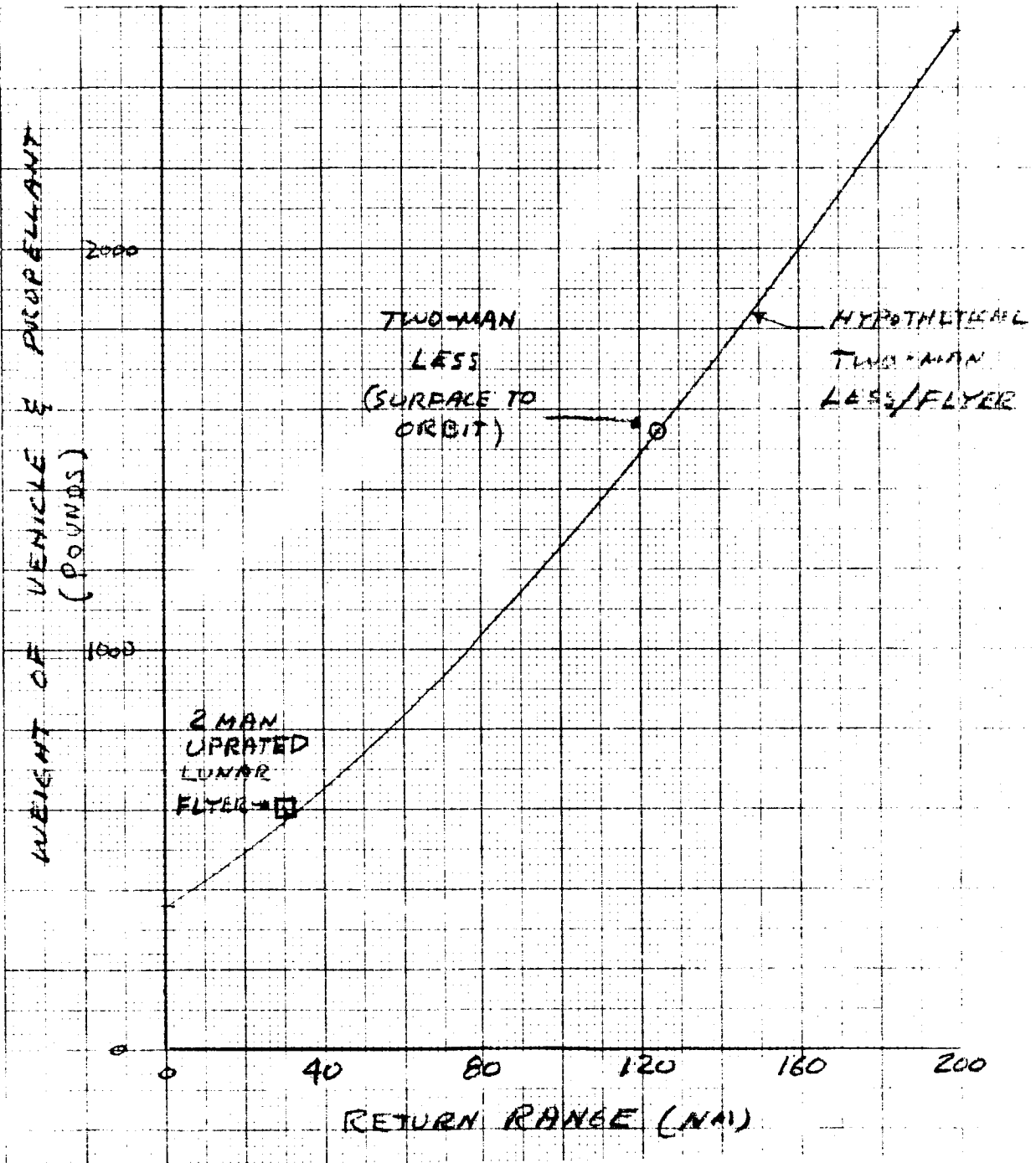

Fig. 7-10 Weight Penalty of Surface-to-Surface Flyers Vs One Way Range

7.2.6.2 Surface-to-Orbit Concepts

The surface-to-orbit LESS weighs about 1,540 lb. The power requirements of the traverse vehicle will increase by a factor of about 1.15 in carrying or towing the LESS. The response time of the escape system depends upon the degree of coordination between the escape vehicle and the space tug on orbit. Figure 7-11 shows the operations involved. Initially, the orbit plane of the space tug may be offset from the position of the emergency site. At point 'A' the space tug is notified of the decision to perform an escape using the LESS vehicle.

After an orbit phasing time delay, point 'B', space tug performs a plane change at orbit altitude. As the space tug approaches the site of the emergency, the LESS makes an ascent at point 'C'. The latter is a bent, two-step trajectory with a vertical rise time of 10 seconds. The total ascent time is about 10 minutes into a circular orbit. This is followed by a rendezvous with the space tug at point 'D'.

The ascent of the escape vehicle requires a high coordination of the vehicle and space tug. The space tug in its new orbit, after plane change, should be tracked electronically by the escape crew.

The total maximum response time is about 5.7 to 7.7 hours, depending upon the vehicle's guidance capability. Table 7-5 summarizes the time requirements for the LESS type vehicle. These response times are marginally compatible with the capacity of a PLSS unit.

A similar operation is performed in the case of an escape using a LEAP-type vehicle. The LEAP-type vehicle requires a 180 degree elliptical ascent transfer orbit because of its limited propulsion capability. The LEAP definitely requires tracking by the orbiting space tug because its ascent is automatically controlled to accommodate the escape of an incapacitated man in a pressurized stretcher; the tug must control the rendezvous maneuvers by the escape vehicle after the latter attains orbit. The response time of this

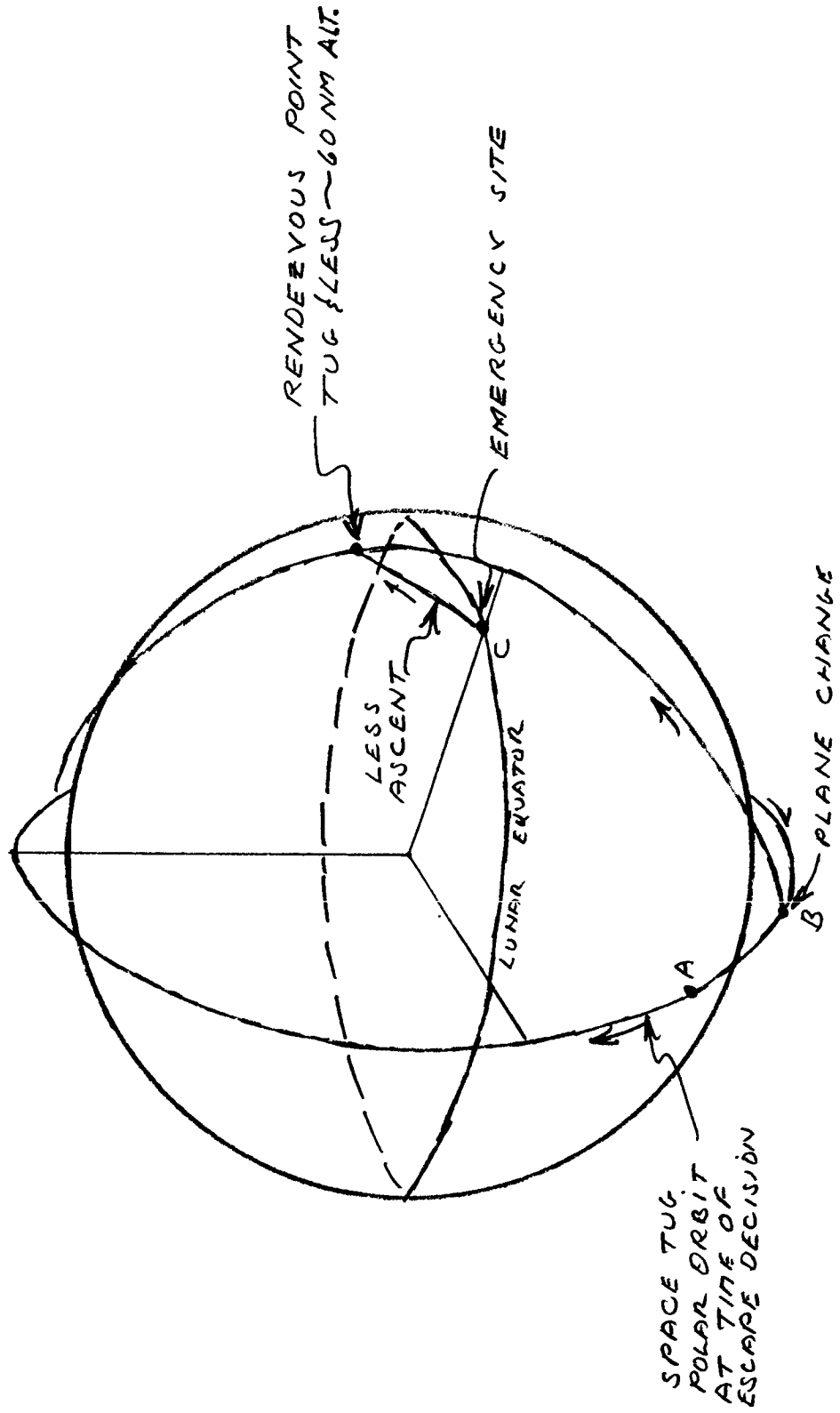

Fig. 7-11 Lunar Escape System (LESS)

concept is 8.5 hours as shown in Table 7-5, and imposes a requirement for life support capacity.

Table 7-5
SURFACE-TO-ORBIT ESCAPE RESPONSE TIME (HOURS)

Operation	Escape Vehicle	
	LESS	Leap-Type
Alert Signal & Escape Decision	0.5	0.5
Space Tug Activation	2.0	2.0
Orbit Phasing (1 orbit)	2.0	2.0
Plane Change of Space Tug	0.5	0.5
Track New Tug Orbit (1 orbit)	2.0	2.0
Ascent to Orbit	0.2	1.0
Rendezvous & Transfer of Personnel	0.5	0.5
Total	7.7	8.5

The use of one two-man flyer vehicle instead of two one-man flyers is preferable because the flyer needs to be manually guided. Therefore, one incapacitated man can be brought back by a normal man on a two-man vehicle. In addition, a two-man vehicle is preferable because it obviates the possibility that one man will be left behind in case the second vehicle fails to lift off. The conclusion is that one two-man vehicle is preferable to two one-man vehicles for escape.

7.2.6.3 Comparison of Escape Techniques

A comparison of the surface-to-surface and surface-to-orbit techniques reveals that the weight penalty is less for the surface-to-orbit technique than for the surface-to-surface method when the return distance is greater

than 120 nm. On the other hand, the space tug may have to make a large plane change in order to rendezvous with the surface-to-orbit escape vehicle.

One solution for the cabin rover traverse escape is to combine the two techniques by having a two-man LESS capable of both a flyer and orbiting mode.

Towing the escape vehicle on a trailer is preferable than attempting to mount the escape vehicle on the cabin rover. It should be easier to prepare the LESS for flight if it is mounted on a trailer; the trailer may also serve as a launch platform.

The carrying of a POGO type vehicle on a lunar flyer has some merit because of the difficulty in rescuing a flyer in rough terrain. The penalty to the mission is severe because the payload capability of the lunar flyer is used to carry the escape vehicle.

The LESS and POGO rescue concepts do not appear to be attractive. In addition, the use of these vehicles appears to be inherently hazardous. They are, therefore, not recommended.

7.2.7 Survival Package Drop for Rescue Support

In case of an emergency on traverse, either the life support capability of the crew is diminished or the vehicle mobility is lost, or both. Dropping a survival package from orbit can, in principle, supply the traverse crew with additional life support equipment. It is doubtful that a survival package can restore mobility since a variety of causes are possible for the loss of mobility. Hence, the purpose of the survival package drop is to provide additional life support equipment.

It seems reasonable that the survival package should provide more life support capability than that provided by an extra backpack per man. A 6,000 Btu backpack can provide a man, who is resting, an additional 12 hours of life support. If the survival package doubles this capability, it will carry the equivalent

of four backpacks for a two-man traverse situation. Hence, the survival package would probably weigh at least 320 pounds. An erectable shelter would also be helpful so that the men can take off their helmets and take on nourishment and water.

The main technical requirements for dropping the survival package onto the surface are as follows:

1. The package must soft land.
2. The landing site must be within a few hundred feet of the traverse vehicle.
3. The package must be launchable through any plane change angle.
4. The response time should be less than the survival time of the men using backpacks.

The first requirement is self-evident. The second requirement is predicated on the reduced capability of an incapacitated man to walk to the survival package, or for two men to walk when they are coupled together on one PLSS in a buddy fashion. The one sigma accuracy of landing system should be $1/3$ the desired landing separation.

It does not seem advisable to use the technique for a walking traverse, or one man traverses. The latter is so because an incapacitated man in a survival bag cannot retrieve the survival package.

The nominal response time for a survival package drop is 3 hours including a 2 hour orbit phasing period, $\frac{1}{2}$ hour for signaling and decision making, and $\frac{1}{2}$ hour for descent.

There are two general concepts for survival package guidance design:

- a. The package acquires, tracks, and generates its error signals based on on-board tracking sensors and a tracking beacon set up by the stranded crew.

- b. The package is acquired, tracked, and error signals are transmitted to the package by the tracking beacon subsystem setup by the stranded crew.

In the second concept the survival package requires only a minimum of on-board guidance, navigation and landing sensors and computation capability. Total weight is lower thus permitting lower thrust levels, and permits the economical use of propellants.

The penalties in providing a survival package drop are as follows:

- o The guidance system will be sophisticated.
- o The propulsion system will probably need a throttlable or restartable motor, and a gimbaled or multi-nozzled engine.
- o The package is a dedicated piece of safety equipment not required for normal lunar operations.

In summary, we can say that the survival package does not add an appreciable increment of success in those cases where it is most needed, viz., where the crew of the disabled vehicle are confined to the vehicle or pressure garments, or when a guidance beacon is inoperable. In addition, survival time may be extended in other ways which impose less penalties on the mission, e.g., carrying extra backpacks or secondary life support systems.

7.2.8 Buddy Vehicles for Escape/Rescue

The buddy concept can be extended to that of providing redundancy in mobility. The portable emergency escape system was one method of providing self-help to the traverse crews. Another method is to send two vehicles on each traverse. In case of the loss of mobility in one vehicle, the second vehicle can return all the men to the base. This system does not reduce the requirements for emergency personal life support.

(This Page Left Blank Intentionally)

The possible combinations of vehicles and their crews are as follows:

1. Two one-man vehicles travel together or independently but within rescue distance of each other. Each must carry and support two men in an emergency.
2. Two two-man vehicles travel together with one man in each vehicle.
3. One two-man vehicle with two men tows an unoccupied two-man vehicle.
4. Two three-man vehicles with two men each travel together or independently but within rescue distance of each other. Each must carry and support four men in an emergency.

Case 1 can be applied to a ground effects machine or a lunar flyer, provided that the vehicle can carry a passenger in lieu of payload. The two vehicles would have to be in constant communication with each other. The advantages of this approach over a rescue from base is that the search requirement is obviated, and the traverse range is not reduced.

Cases 2 and 3 may be applied to the rover vehicles. The advantages are that search is unnecessary and that the range of the traverse is not reduced.

Case 4 is recommended for the rovers.

The main advantage of the plans is the short time to respond to an emergency; the disadvantage is the inefficiency of using two vehicles for one mission.

7.2.9 Comparison of Lunar Surface Traverse Escape/Rescue Concepts

A summary of the main characteristics of the various escape/rescue concepts is given in Table 7-6. The several factors which have been evaluated are defined as follows:

1. Applicable Traverse Situation. Those situations for which the concept is most suitable.

TABLE 7-6
SUMMARY OF ESCAPE/RESCUE CONCEPTS
FOR LUNAR SURFACE TRAVERSES

Concept	Applicable Traverse Situation	Nominal Escape/Rescue Response Time (hrs)	Sensitivity to Crew Incapacitation
Walkback	Foot Traverses	2	One crewman must be mobile
4-Wheel EVA Rovers	Foot Traverses	4.9	Insensitive
6-Wheel EVA Rover Vehicles	Foot Traverses EVA Rover	4.5 6.1	Insensitive
Pressurized Cabin Rover	Foot Traverses EVA Rover Lunar Flyer Ground Effect Machine	4.9 7.4 8.2 10.6	Insensitive
LESS/Flyer from Base	All EVA Traverses Pressurized Cabin Rover	3.7 3.9	Insensitive
Lunar Lander Tug from Surface (Flyer Mode)	Pressurized Cabin Rover	5.5	Insensitive
Lunar Lander Tug from Orbit	Pressurized Cabin Rover	8.1	Insensitive
Portable Escape System Combined Surface-to-Surface & Orbit-to-Orbit	Pressurized Cabin Rover	8.5	Crew must be able to fly vehicle in EVA mode
Portable Escape System, Surface-to-Surface	Lunar Flyer EVA Rover Ground Effect Machine	1.0	Crew must be capable of erecting & flying vehicle in EVA mode
Survival Package Drop	All vehicle traverses	3.0	Crew must traverse to drop site and operate guidance and beacon
Buddy Vehicles	All vehicular traverses	-	Relatively insensitive

Escape/Rescue Vehicle Requirements	Mission Penalties	Design Penalties
Need means of moving incapacitated crewmen -- hand cart	Extra equipment Limits Range	Extra Weight
3-Man minimum crew capacity	Dedicated vehicle - not used for normal oper'ns	-
3-Man minimum crew capacity	Dedicated vehicle - not used for normal oper'ns	-
Driver position for EVA mode & emergency 3-man cabin capacity	Dedicated vehicle - not used for normal operations	-
Capability to carry 2 pressurized stretchers & 1 tracking beacon	Dedicated vehicle - not used for normal operations	Gimballed engine Attitude control Handcart needed
Carry EVA rover vehicle & tracking beacon	High Δ velocity reqmt; Tug assigned mission terminated	Wide search field of vision; Land under any lighting conditions
Carry EVA rover vehicle & tracking beacon	90° plane change; 14-day survival on surface	Land under all lighting conditions
Automatic ascent & orbit insertion; 2-man capacity	Traverse velocity & mobility decreased; Tug makes 2 plane changes	Vehicle trailer & automatic guidance/navigation system needed
POGO-type vehicle characteristics	Mission payload decreased	Flyer must carry escape vehicle
Minimum 24-hrs survival capability; Shelter location aids	Dedicated hardware	New orbital & landing spacecraft needed
Vehicle-to-vehicle characteristics	2 vehicles used on each mission	

2. Nominal Escape/Rescue Response Time. The time from the rescue alert until the rescue team arrives at the site of the emergency, or until the crew escapes to a safe haven. Rescue team preparation is included but no time allowances are made for extended search.
3. Sensitivity to Crew Incapacitation. The dependency of the evacuation of the distressed crew upon their capability to walk and/or perform tasks, such as flying a vehicle.
4. Rescue, Escape Vehicle Requirements. The main features of the vehicle needed for traveling, searching, and carrying of crew and passengers.
5. Mission Penalties. The cost to the lunar program in terms of dedicated equipment, added ΔV , redundancy, and performance degradations that diminish scientific payload and exploration.
6. Design Penalties. The main features of design above and beyond that needed for the normal lunar mission.

The data of Table 7-6 shows that no single concept is adequate nor preferred for all situations. The practicality of the concepts is dependent upon whether the traverses are associated with the permanent lunar surface base or a temporary tug on sortie. The resources on the surface available to the latter are considerably less than the former, especially if the sorties are accomplished with one tug and if the scientific equipment and payload are substantial.

A reasonable general approach for both the permanent base and the tug on sortie is based on the backup principle rather than the buddy principle. The backup approach reduces the useless expenditure of consumables, i.e., an expenditure when no emergency occurs. It depends on having a mix of vehicles available which gives several rescue or escape alternatives.

The one exception to the general approach is that for the long range pressurized cabin rover traverses, buddy rovers are preferred. The lander tug on orbit may perform a surface rescue in the event that both cabin rovers fail.

For EVA traverses in the near vicinity of a base or lander tug, one vehicle should be kept near the base or tug while the other vehicle is on traverse. Emergency survival capability should be carried on the traverse vehicle sufficient to allow time for the second vehicle to perform a rescue. In the special case where a lunar flyer traverses to location inaccessible by rover vehicle, buddy flyers or standby rescue flyers at the base are recommended.

The development and deployment of a survival package for unmanned landings at the emergency site appears less desirable than providing extra personal life support equipment on the traverse vehicle for purposes of extending survival time.

A dedicated lander tug at the lunar orbiting lunar station is required to back up escape and rescue operations. This requirement is consistent with the needs of the safety of the permanent surface base and the tug on sortie.

7.3 ESCAPE/RESCUE GUIDELINES FOR LUNAR SURFACE TRAVERSE OPERATIONS

1. Pressure suits must have the capability for automatically sealing suit rips or tears.
2. Each crewman needs an emergency pressure garment available at all times (including when in pressure suits and on EVA). These garments should be capable of being converted to a stretcher by the addition of rods or poles.
3. Backpack units must be so designed that a second EVA crewman could plug into a unit worn by a 'buddy' crewman. The time span required for plug-in and switch-over should be on the order of a few seconds.
4. An emergency backup life support system or oxygen supply system is required to extend the survival time of a traverse crew. The choice and design of each will be a function of the required survival time needed to satisfy the requirements of a particular traverse mission.
5. Rover vehicles that are to be used as potential rescue vehicles must have the payload capability to carry the rescue crew (including vehicle driver) and the stranded crewmen. The vehicle payload area and volume must have the capability for carrying the stranded crewmen whether they are in

- pressure suits, emergency garments, or in a pressurized stretcher.
6. A pressurized cabin rover vehicle used for rescue should have dual controls: one set inside the pressurized cabin, the other outside the cabin and so arranged that a crewman in a pressure suit could control the vehicle.
 7. All rover vehicles should be capable of carrying a nominal minimum of three crewmen including the driver. Each rover should have a minimum emergency capability to support and transport four crewman, including the driver. Capability should be provided to care for two men in pressurized stretchers.
 8. Lunar surface mobility vehicles operated beyond walk-back distance should be used in pairs, with each vehicle capable of carrying and supporting all crewmen of both vehicles in an emergency.
 9. All surface rescue vehicles should have the capability for hoisting and carrying an incapacitated man in a pressurized stretcher. Implied here is the capability of interconnection between the vehicle life support system and the stretcher.
 10. Mobile vehicles used for traverse missions should carry the following types of emergency communication equipment:
 - a. Rocket propelled radio beacons
 - b. Tracking beacon to aid a rescue tug in locating an emergency site
 - c. Landing and touchdown location aids
 11. All rover and flyer vehicles must be capable of activation in no more than 2 hours.
 12. Any vehicle that is designed for automatic (hands-off) operation must be capable of full manual operation and control by a crewman in a pressure suit.
 13. A handcart, similar to that used on Apollo 14, should be carried by each lander tug. The handcart should be capable of carrying an incapacitated man either in a pressure suit or a pressurized stretcher.
 14. Lunar flyers used on missions into rough terrain areas that are inaccessible for surface vehicles should be sent in pairs, with each capable of returning the crews of both vehicles.

15. A flyer that is used as a rescue vehicle must have a minimum range radius greater than the traverse radius of the surface vehicles that it is supporting.
16. The flyer must be capable of acquiring and tracking the location beacons to be carried by all traverse and flyer vehicles.
17. A lunar flyer used for rescue should have a payload capability of a minimum of three men - one pilot plus two incapacitated men in either pressurized stretchers or normal pressure suits.
18. The cargo capacity of a flyer on the outboard leg of a rescue mission should be used to carry special gear such as tools, stretcher cart, etc. This equipment can be abandoned for the return trip, thereby providing additional cargo capability.
19. The time required for activation of the rescue mission (time span from receipt of rescue alert communication to departure of the rescue vehicle and crew) must be no more than 2 hours.
20. A wheeled "stretcher" cart should be carried by a rescue flyer as standard equipment.
21. A lunar lander tug used as an orbital rescue vehicle for surface rescue missions must carry an EVA-type rover vehicle with a minimum three-man capacity, including the driver.

Section 8

EFFECT OF NO ORBITING LUNAR STATION ON ESCAPE/RESCUE PLAN

It is possible that the orbital lunar station could be deleted from the lunar program or that its deployment into lunar orbit could be delayed. The purpose of this section is to explore some of the possible consequent effects on escape/rescue and to define at least one possible operating mode for supporting lunar surface activities.

With no orbiting station one possible operating mode is similar to that used during the Apollo program lunar landing operation. The PTV and lander tug combination would probably insert into a lunar orbit that minimizes plane change requirements with respect to the desired surface landing site. After a suitable checkout and phasing interval the lander tug would separate from the PTV and perform an Apollo-type landing sequence. The lander tug would then remain on the surface long enough to await the orbiting PTV orbit plane to become aligned (due to the lunar rotational rate) with the landing site. This minimum plane change requirement opportunity occurs once every 14 days.

Once manned and activated the LSB could function as the primary lunar rescue base. The LSB would require a means for rescue using surface traverse, flyer, or orbital type rescue vehicles. Remote surface sites would require the capability for survival (perhaps shelters) or escape into orbit. Such an orbital escape vehicle would need up to a 14 day survival capability to ensure that its orbital track would pass close enough to the LSB that a rescue vehicle from the base could ascend into orbit and complete rendezvous with the escape vehicle with only a minimum plane change.

If the LSB was to serve as the primary rescue base consideration should be given to landing and activating the LSB prior to start of the lunar lander sortie program. In addition the LSB surface site should be optimized with

respect to the time-phase deployment and site location of the lander tugs. If no optimized location could be found, consideration should then be given to more than one LSB.

With no orbiting station one of the primary escape/rescue problem areas would be that of the required delta velocity needed for escape/rescue operations. This problem could be handled by locating a fuel depot at the LSB so that the standby/rescue tug vehicle would have full delta velocity capability available for rescue or for escape to Earth vicinity directly from the base.

Another alternative would be to maintain a PTV, manned or unmanned, in a 60 nm polar lunar orbit to provide the required delta velocity for transfer to Earth vicinity. This approach would permit a tug, located at the lunar base to be able to make a 90° ascent plane change, and complete rendezvous and docking with the PTV for a return to Earth vicinity. Locating a fuel depot at the LSB would provide the capability for rescue tug refueling at the LSB and thus provide sufficient delta velocity capability for lunar orbital injection with up to a 90° plane change.

Section 9

EFFECT OF NO LUNAR SURFACE BASE ON ESCAPE/RESCUE PLAN

The effect on the escape/rescue plan of not locating a lunar surface base on the lunar surface should be relatively minor. For orbital-based rescue the lack of a LSB is of no serious consequence since, in effect, this lack simply eliminates a potential rescue situation and site.

Without an LSB, surface based rescue would probably be impractical since there would be no permanent base at which surface rescue vehicles could be stored and maintained. All rescue operations would therefore normally originate from orbit. The safe haven would either be the orbiting station or the Earth vicinity. If no station were available all escape or rescue vehicles would have to return to the Earth vicinity either via the orbiting PTV or using direct tug delta velocity capability. The latter alternative is probably impractical unless the capability existed in the lunar vicinity for tug refueling prior to trans-Earth injection.

It follows that the station should be manned, functional, and operational prior to the initiation of manned landings and surface operations.

Section 10

EFFECT OF FOREIGN LUNAR ORBIT/SURFACE OPERATIONS ON ESCAPE/RESCUE PLAN

It seems probable that other nations (primarily USSR) will initiate lunar exploration programs that could function virtually independent of any NASA program. For example, a Russian lunar program almost certainly will use hardware and vehicles different from that of NASA in design, function, and purpose. Deployment in terms of such items as orbital inclination, altitude, surface landing sites, and operational sequencing will probably differ markedly from that of NASA.

It follows that any foreign lunar exploration program could generate escape/rescue situations similar in nature to those presented in other sections in this report. However the effects of this potential increase in rate and frequency of situations is at least partially offset by the additional resources in terms of crewmen, communications capability, equipment deployment, types of hardware, and functional capability.

In order to take advantage of these additional resources, a coordinated escape/rescue plan should be prepared involving at least the following:

- a. Compatibility of equipment in critical functional areas such as communications, docking, rendezvous, forced entry, entry point size and number, and emergency equipment.
- b. Location aids.
- c. Escape/rescue procedures and techniques.
- d. Crew training including familiarization with each nation's emergency equipment.
- e. Operational coordination at the working level.
- f. Language or some means of direct person to person communication. Perhaps a common sign language that includes symbols for potentially critical bits of information.

- g. Compatible atmospheres.
- h. Common emergency alarm equipment and techniques. The same signal should mean the same thing to all participating countries.

SECTION 11

DESCRIPTION OF PORTABLE AIRLOCK AND EMERGENCY PRESSURE GARMENT

Two items of emergency equipment recommended for use in advanced lunar exploration are identified below. These are a portable airlock and an emergency pressure garment.

11.1 EMERGENCY PORTABLE AIRLOCK

The emergency portable airlock is shown in Figure 11-1 in both the packaged and expanded configuration. The airlock depicted is currently planned as a Skylab experiment (D-021). In its current version the D-021 portable airlock packaging system consists of a series of flexible nylon straps, located around the periphery of the mounting structure (upper left view in Figure 11-1), to restrain the expandable portion of the airlock structure in a packaged configuration. Deployment is manually controlled by an easily reached lanyard pull mechanism.

The airlock expandable structure consists of a composite wall material which is bonded and joined to aluminum terminal rings at each end of the airlock. These rings provide a rigid termination for the flexible material of the airlock and also provide a smooth flat surface for hatch and pressure bulkhead seals. The expandable portion uses elastic recovery materials to permit folding and packaging into a compact configuration for storage and ease in carrying. When actuated the airlock deploys to its full expanded configuration by the recovery action of the wall material, augmented by low level pressurization for final shaping. After final shaping, the inherent stiffness of the wall structure will ensure the final shape is maintained under both lunar orbital and surface conditions. Full expansion of the airlock requires 120 seconds.

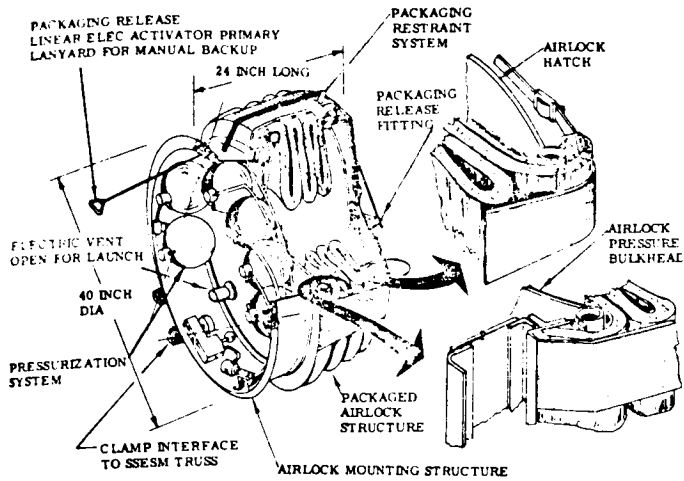

← **Packaged Configuration**

Major Components and Subassemblies ↗

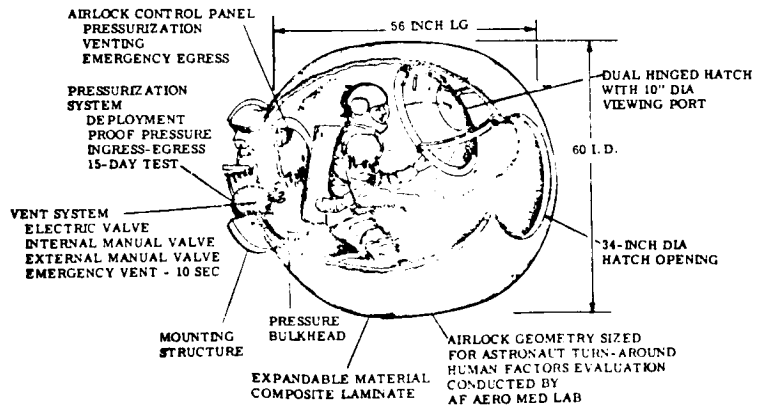
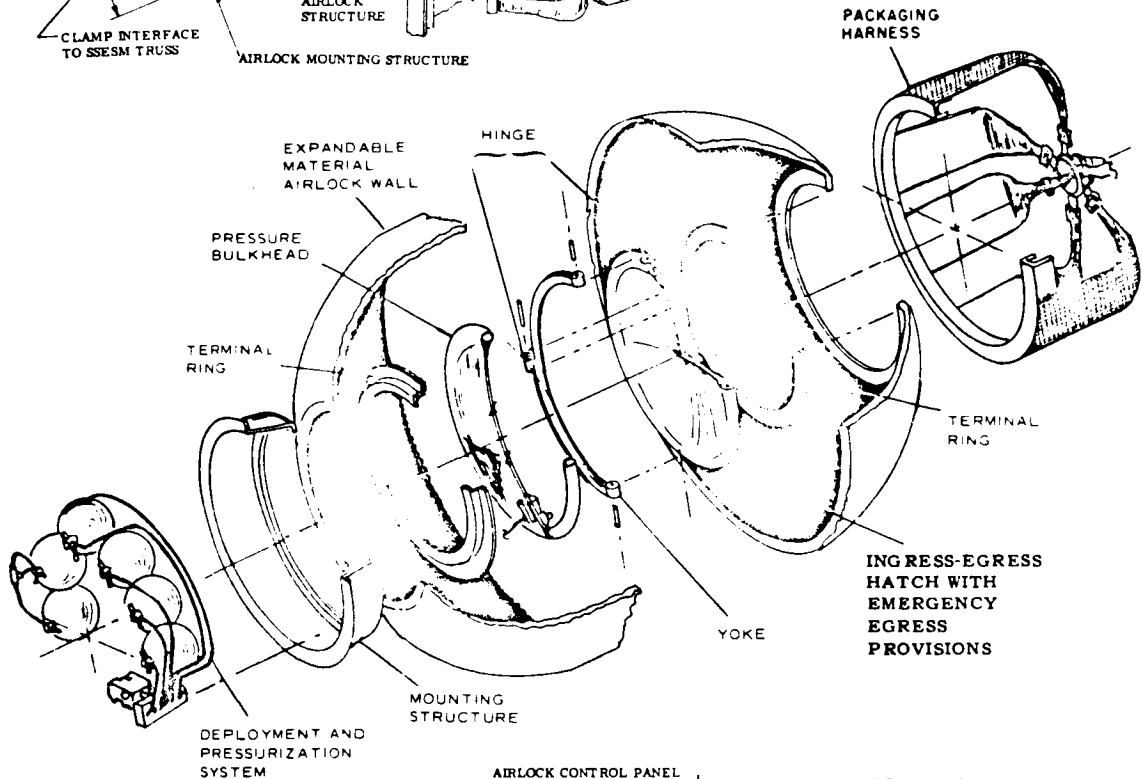

Expanded Configuration ↗

Ref: Second National Conference on Space Maintenance and Extravehicular Activities
 6, 7, 8 August 1968, Page VII. 4.15

Fig. 11-1 Emergency Portable Airlock
 (Skylab Experiment D-021)

11.2 EMERGENCY PRESSURE GARMENT

The emergency pressure garment is a system designed to provide backup protection for a suited crewman or for a crewman in shirtsleeves. Figure 11-2 illustrates a concept for use by an EVA astronaut in the event of damage to the normal pressure suit. Figure 11-3 illustrates a concept for use by a crewman in shirtsleeves in a pressurized cabin environment where pressure is decaying or atmosphere has become contaminated.

The garment consists of two primary parts: (1) a loose fitting coverall made of clear plastic, which may require reinforcement, and (2) a pressure regulated oxygen supply system.

The clear plastic coverall can completely enclose the crewman including a pressure suited crewman's backpack. There is a pressure tight closure on the front. The garment is in one size only and can be donned and activated by an unsuited crewman without assistance. However, a crewman in a full pressure suit would require assistance by another crewman, as illustrated in Figure 11-2.

The garment contains either a pressure relieving check valve or a calibrated orifice that maintains the garment internal pressure at 3.5 ± 0.3 psi. The oxygen supply system can be supported and retained by a pair of velcro backed over-the-shoulder supports. The facing velcro pads would be mounted on the crewman's coveralls or pressure suit shoulder area.

The oxygen supply system is an open loop flush flow system that provides thirty minutes of oxygen at a flow rate of 8 lbs/hour to the garment helmet area. This flow rate would provide sufficient oxygen for breathing, respiratory flushout, visor defogging and maintenance of garment pressure.

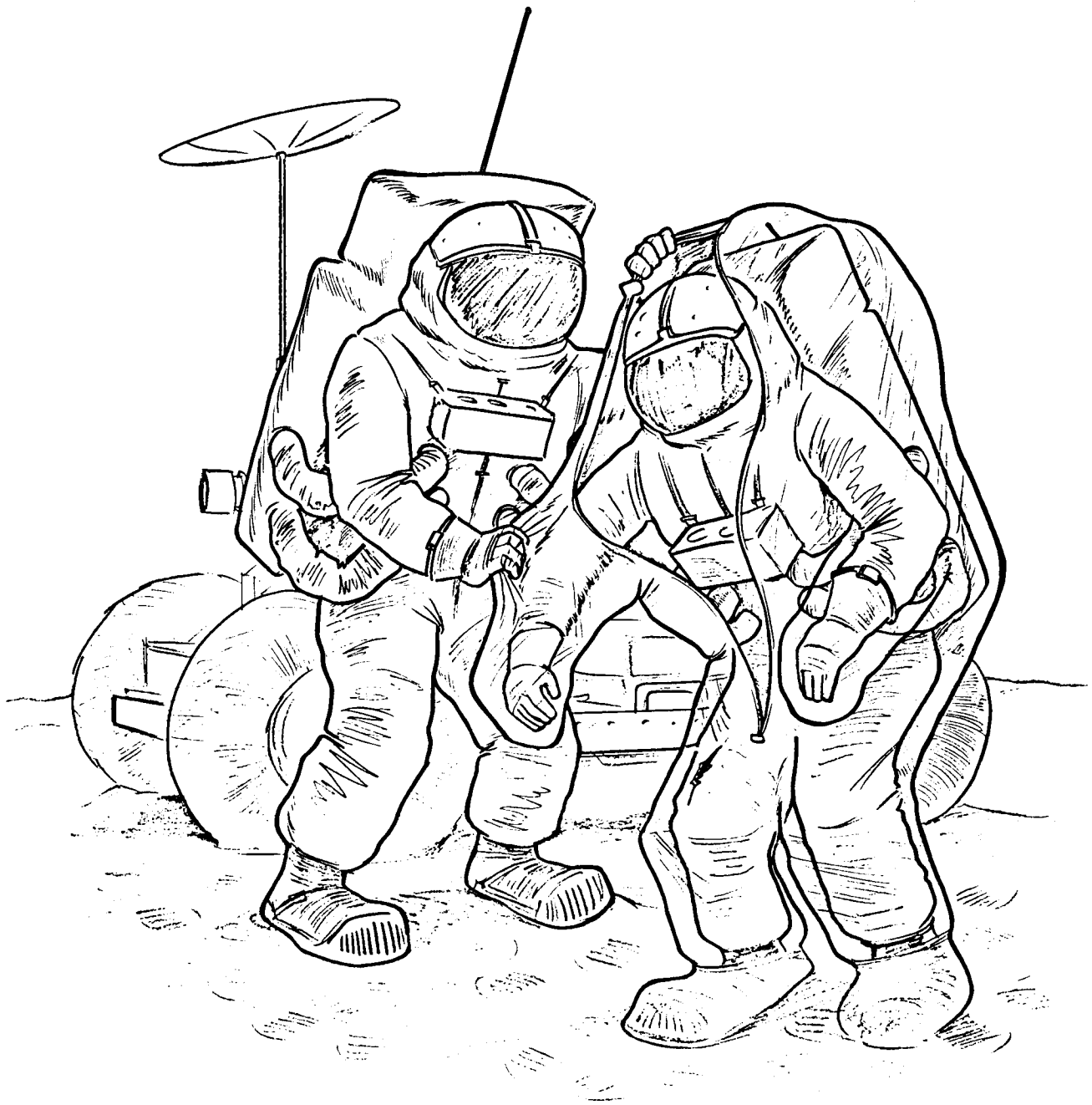

Fig. 11-2 Emergency Pressure Suit for EVA Crewmen



Fig. 11-3 Emergency Pressure Garment for Crewmen in Shirtsleeves

The oxygen supply system consists of a single tank holding 4 lbs. of useable oxygen at 5,880 psi, a single-stage pressure regulator that maintains suit inlet pressure at 3.7 ± 0.3 psi, a heater to maintain suit inlet oxygen temperature between 30 and 80°F, a temperature sensor connected to an automatic heater controller, and a small battery to provide power. A hand control valve is provided to initiate oxygen flow after the garment is donned and sealed. The oxygen supply unit should weigh less than 40 lbs (Earth weight) and should have a volume less than 1400 cubic inches.

The proposed emergency oxygen supply system would not be required by crewmen on EVA since the emergency pressure garment would be donned over the normal backpack.

APPENDIX A
LUNAR ESCAPE/RESCUE ORBITAL VELOCITY NEEDS

This section presents baseline data from which the delta velocity requirements can be estimated for performing various escape/rescue operations involving orbital flight. These data are presented in four parts as a function of the required orbital operation:

1. Lunar orbital rescue from each orbit.
2. Lunar surface rescue from lunar orbit.
3. Lunar rescue from libration point.
4. Missed lunar insertion rescue from lunar orbit.

1. Lunar Orbit from Earth Orbit

- a. Translunar injection velocity requirements from Earth orbits of 100 and 262 n.m. are given. These same curves are also valid for Earth orbit injection.
- b. Lunar orbit insertion and departure velocities are given for both co-planar and out-of-plane insertions and departures using optimized single impulse and three burn techniques.

2. Lunar Surface from Lunar Orbit

Rescue from the lunar surface by descent from lunar orbit involves two considerations; the maximum plane change angle that will be required and the velocity requirements to accomplish the plane change and descent. The independent variable is time to rescue which, in general, is inversely proportional to the velocity requirements for descent.

Maximum plane change angles for various latitudes and orbit inclinations are given along with descent and ascent velocity requirements including plane changes for various trajectories.

In addition, the velocity requirements for orbital plane and altitude changes are included:

3. Lunar Rescue from Libration Point L_2

Velocity requirements for entering lunar orbit from the L_2 libration point are given as a function of flight time. The minimal requirement for any plane change is pointed out.

4. The concluding set of curves is for velocity requirements to rendezvous with a vehicle that failed to burn at lunar orbit insertion, and the velocity requirements required to return to lunar orbit for various delay times after the vehicle has passed the approach hyperbola periselene.

Earth/Moon Geometry

The basic relations of the Earth and Moon to the ecliptic plane and each other are shown in Figure A-1. The Moon Orbital Plane (MOP) about the Earth is inclined at 5.15 degrees to the ecliptic. The orbit itself is not quite circular, thereby providing a variation in the Earth/Moon distance. The effect of the variation is slight, resulting in approximately a difference of 100 ft/sec in translunar injection delta V requirements between maximum and minimum distance.

Translunar Injection

The delta V required for co-planar translunar injection from an Earth orbit is shown on Figures A-2 and A-3 for Earth orbits of 262 n.m. and 100 n.m., respectively. The velocity requirements are a function of translunar flight time primarily. The max and min curves match the variation in the Earth/Moon distance.

Inclinations and Plane Change Angles

The basic reference for Earth and lunar orbit inclination is the Moon orbital plane. The lunar equator (perpendicular to its spin axis) is inclined at a constant 1.55 degrees to the ecliptic, and consequently 6.7 degrees to the Moon orbital plane. The Earth's equator is inclined 23.5 degrees to the ecliptic. Inclination of orbiting vehicles is normally referenced to the equator of the central body. The Moon orbital plane is the common reference between the Earth and Moon. The inclination of the Earth to the Moon orbital plane as shown in Figure A-1 is 23.44 degrees plus 5.15 degrees or 28.6 degrees.

Due to the rotation of the line of nodes of the Moon's orbital plane with a period of 18.6 years, the inclination of the Earth's equator to the

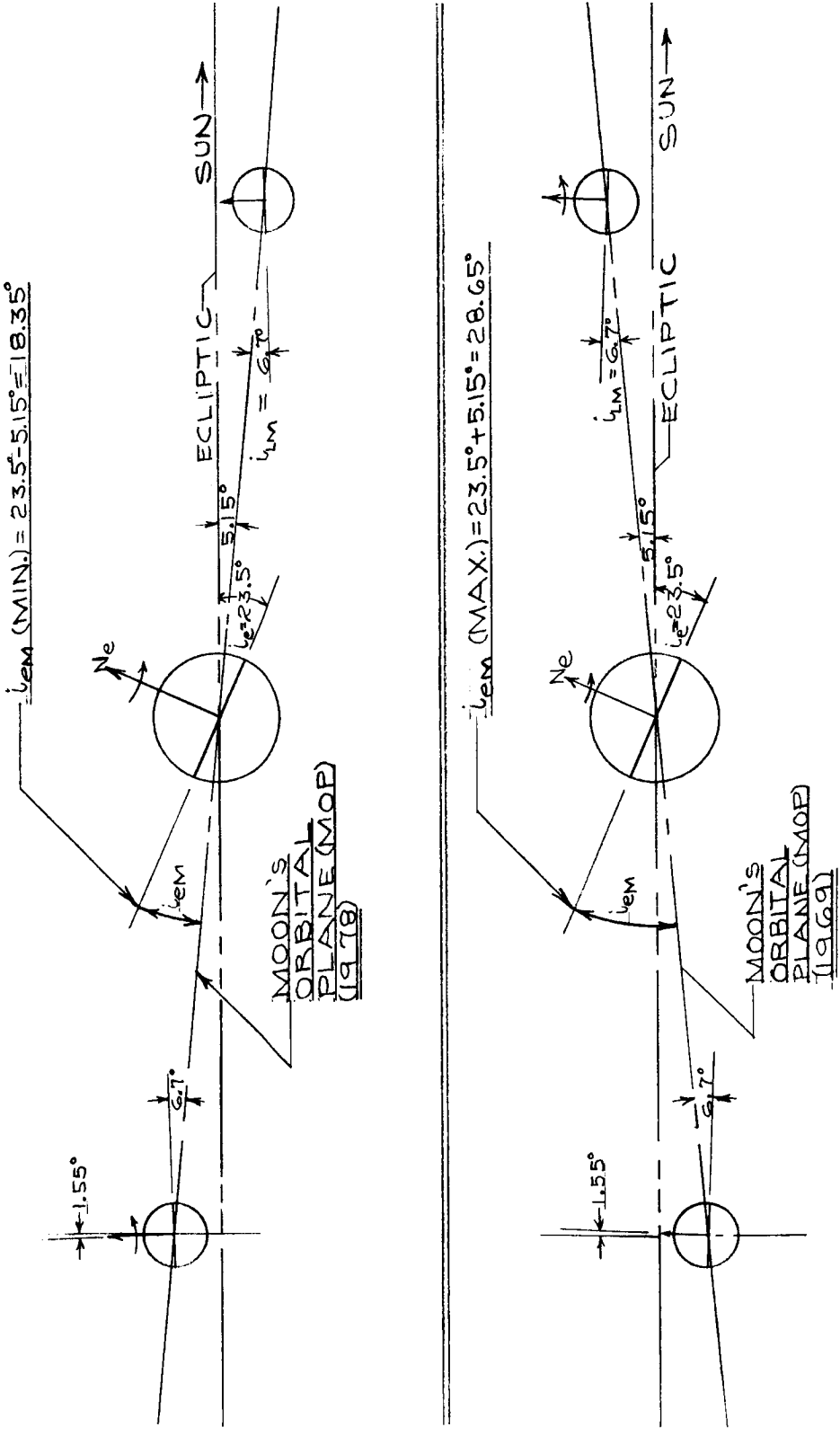

EARTH-MOON GEOMETRY SHOWING EFFECT OF THE REGRESSION OF THE LUNAR ORBIT NODES (PERIOD = 18.6 years) ON INCLINATION OF THE EARTH EQUATOR TO THE MOON'S ORBITAL PLANE (i_{em}).

Fig. A-1 Earth-Moon Geometry

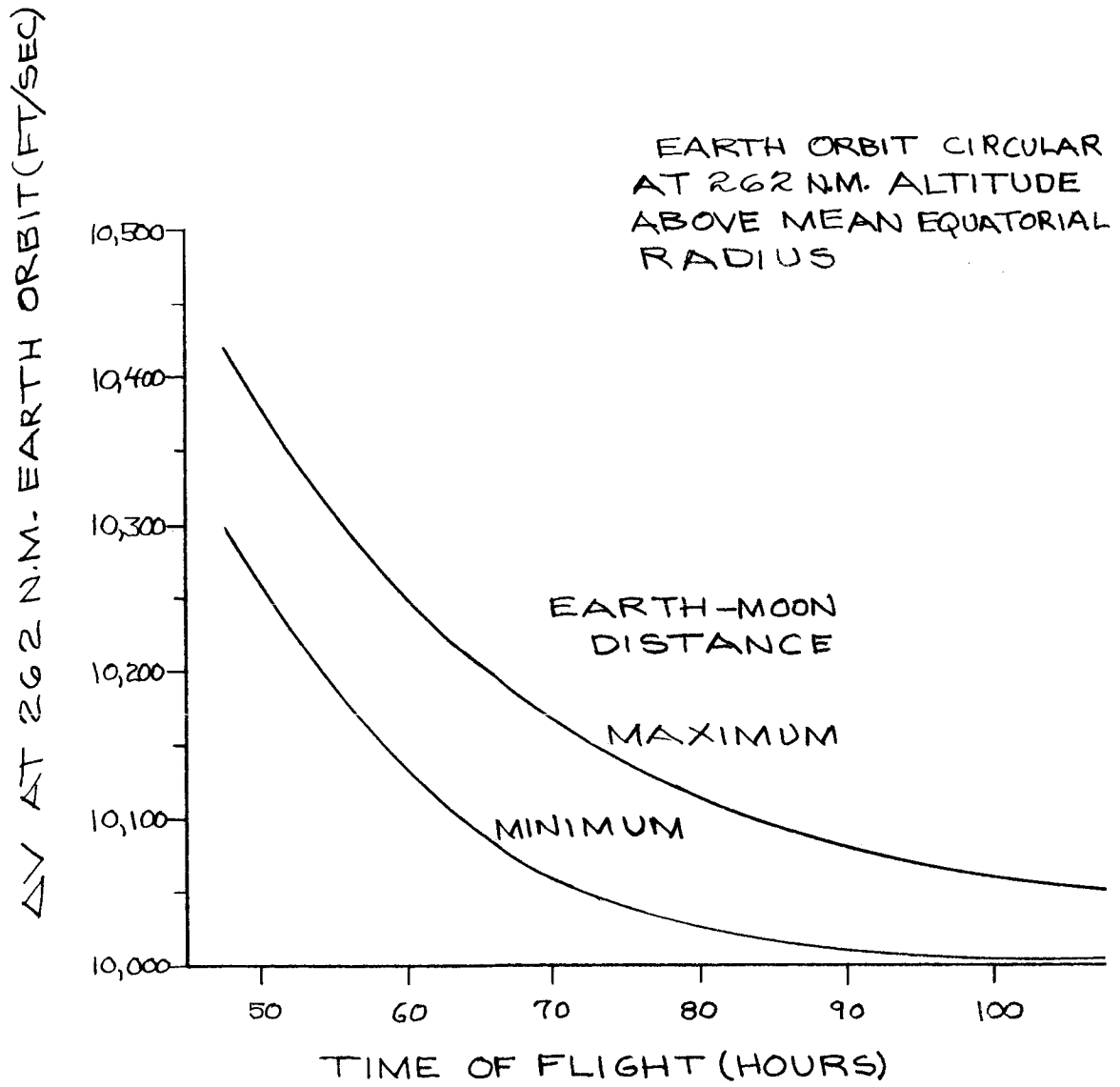

Fig. A-2 Lunar Mission ΔV at Earth Orbit Departure or Return

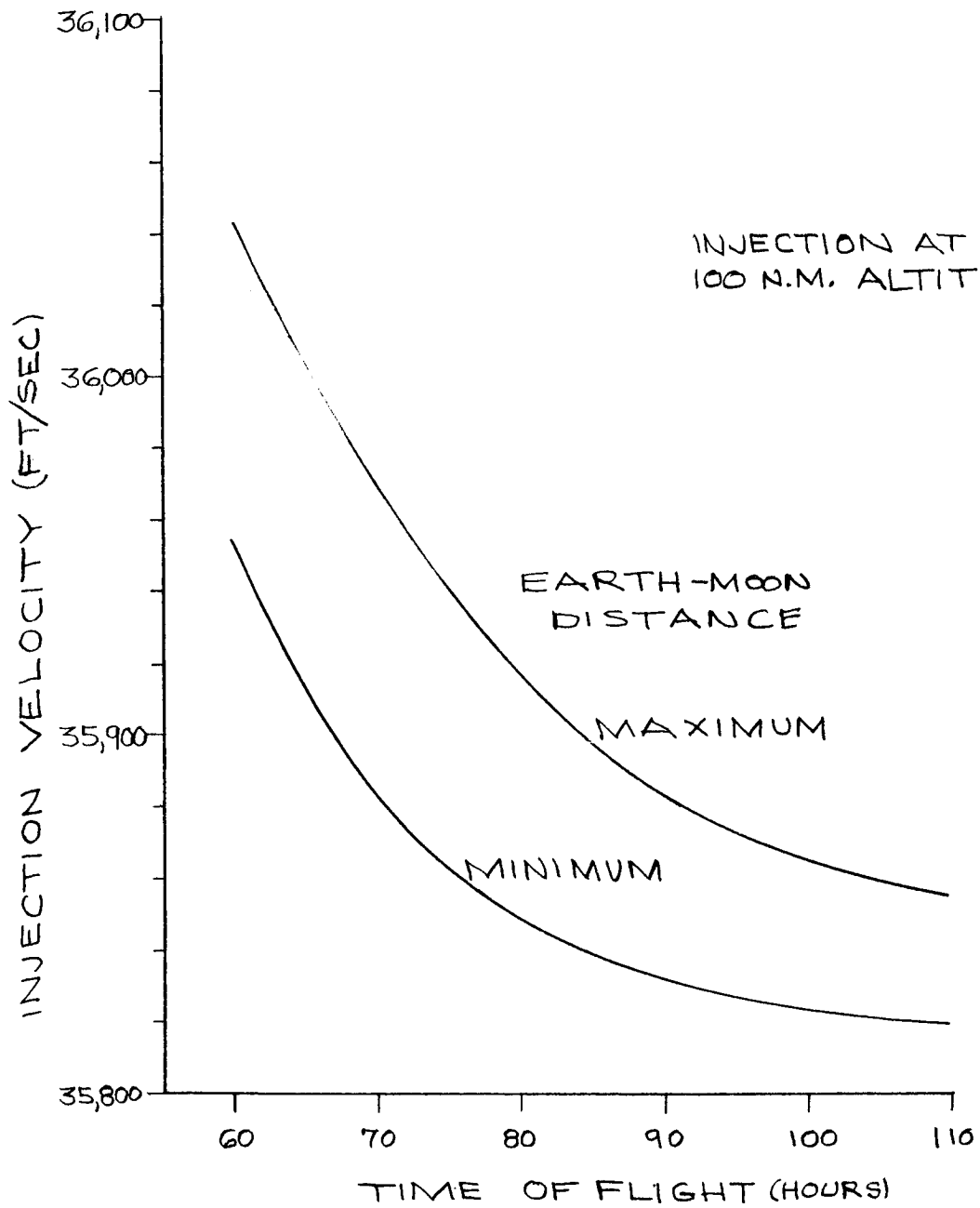

Fig. A-3 Translunar Injection Velocity Requirement

Moon's orbital plane (i_{em}) varies by $\pm 5.15^\circ$, the inclination of the Moon's orbital plane to the ecliptic. This effect is shown in Figure A-1 which depicts the relationship 9.3 years later. The variation of i_{em} as a function of time is illustrated in Figure A-4. More precise values can be obtained from the "American Ephemeris and Nautical Almanac." A value of $i_{em} = 20^\circ$ for 1980 has been chosen for the determination of the inclination of the plane of the translunar trajectory to the Moon's orbital plane (i_r) in the following graphs according to the equation:

$$i_r = i_{eo} \pm i_{em}$$

where

i_{eo} = inclination of Earth orbital plane

i_{em} = inclination of Earth's equator to the
Moon's orbital plane

i_r = inclination of trajectory plane to Moon's
orbital plane

Figure A-5 is a plot of delta V versus flight time for i_r 's of $8.5^\circ/48.5^\circ$, corresponding to a 28.5° Earth orbit inclination and 75 degrees for an Earth orbit inclination of 55 degrees.

The angular relations of the various inclinations for these trajectories are shown on Figure A-6. For each Earth orbit there are two possible translunar trajectories corresponding to injection after passing the ascending node or the descending node.

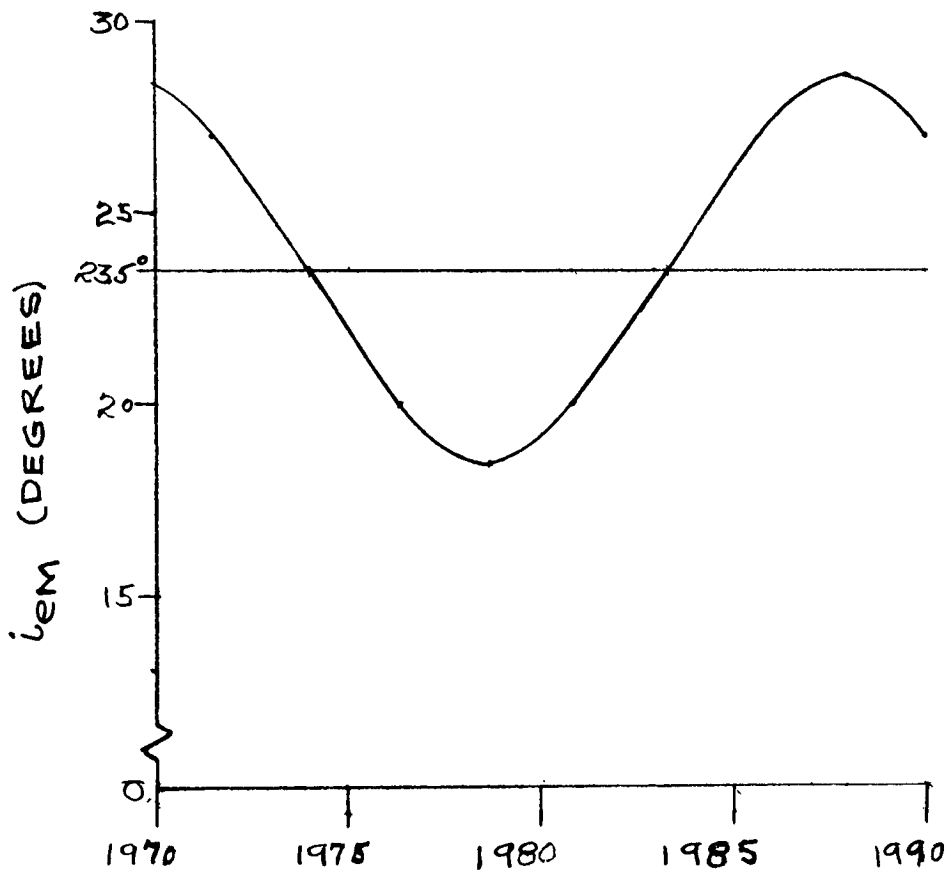

Fig. A-4 Inclination of Earth Equator to Moon's Orbital Plane

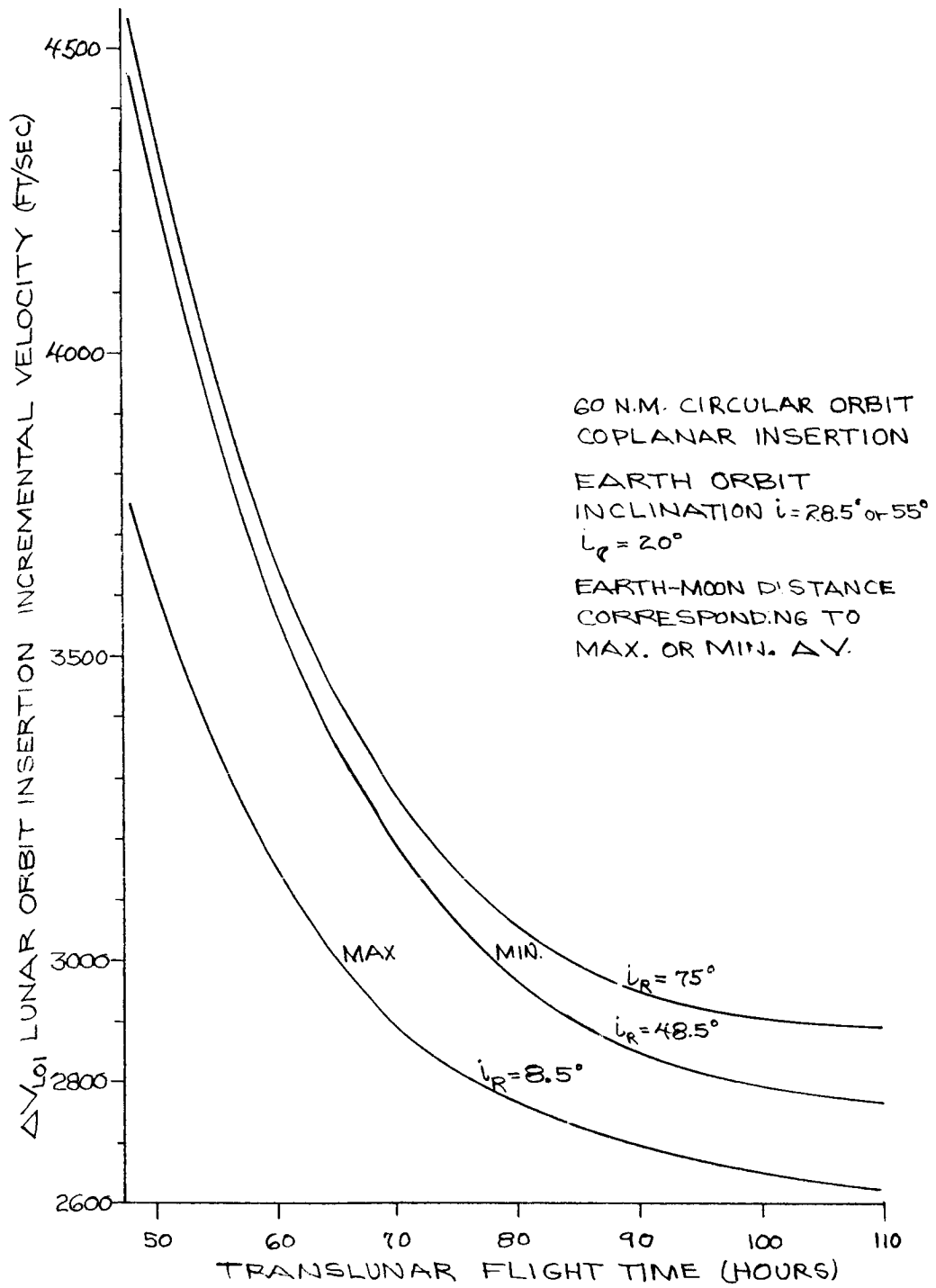

Fig. A-5 Lunar Orbit Insertion ΔV

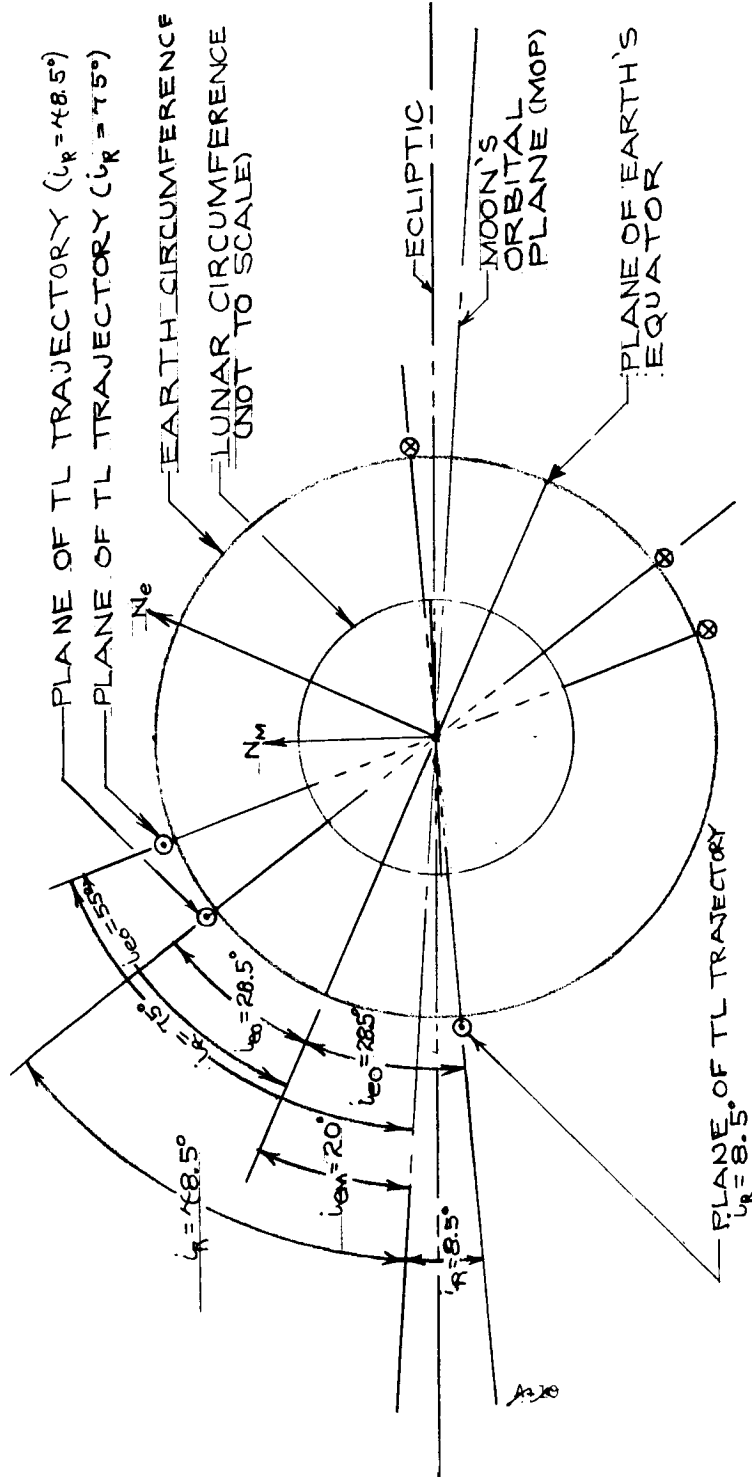

Fig. A-6 Inclinations for Trajectories on Fig. A-5
 $i_{eo} = 28.5^\circ$ & 55° ; $i_{em} = 20^\circ$ (1980)

Velocity Requirements (ΔV) for Plane Changes (α)

The velocity requirements for out-of-plane angles at Lunar Orbit Insertion (LOI) for optimum single impulse burn are shown on Figure A-7 with flight time as a parameter. The reference Earth orbit for these requirements is 262 n.m. and 28.5 degrees inclination.

The minimum/maximum values for each flight time represent the effect of varying Earth/Moon distance as shown in Figure A-2 and the inclination of the transfer plane to the Moon's orbital plane (i_T) for $i_T = 8.5$ (minimum) and $i_T = 48.5$ (maximum) as given previously in Figure A-5.

To use the optimum single impulse for lunar orbit insertions with out-of-plane angles (α), the pericenter must be targeted at translunar injection. For the larger α 's the targeted pericenter is below the desired circular orbit. This is shown in Figure A-8 which gives the difference between the targeted pericenter and the 60 n.m. lunar orbit that would occur if the lunar orbit insertion burn failed to occur.

This hazard can be removed by raising the targeted pericenter by an amount equal to the altitude above 60 n.m. circular orbit that would result if the ΔV 's for plane change from Figure A-7 were used for insertion with no plane change. The resulting pericenter altitudes are shown on Figure A-9 as a function of out-of-plane angle (α) for various flight times.

If plane change angles are constrained to targets no lower than 60 n.m., the resulting maximum allowable out-of-plane angles are shown on Figure A-10 which is a cross-plot of Figure A-9 with this constraint. The min/max curves correspond to the minimum/maximum ΔV cases of the previous figures which are a function of Earth/Moon distances and trajectory plane inclination $i_T = 8.5/48.5$.

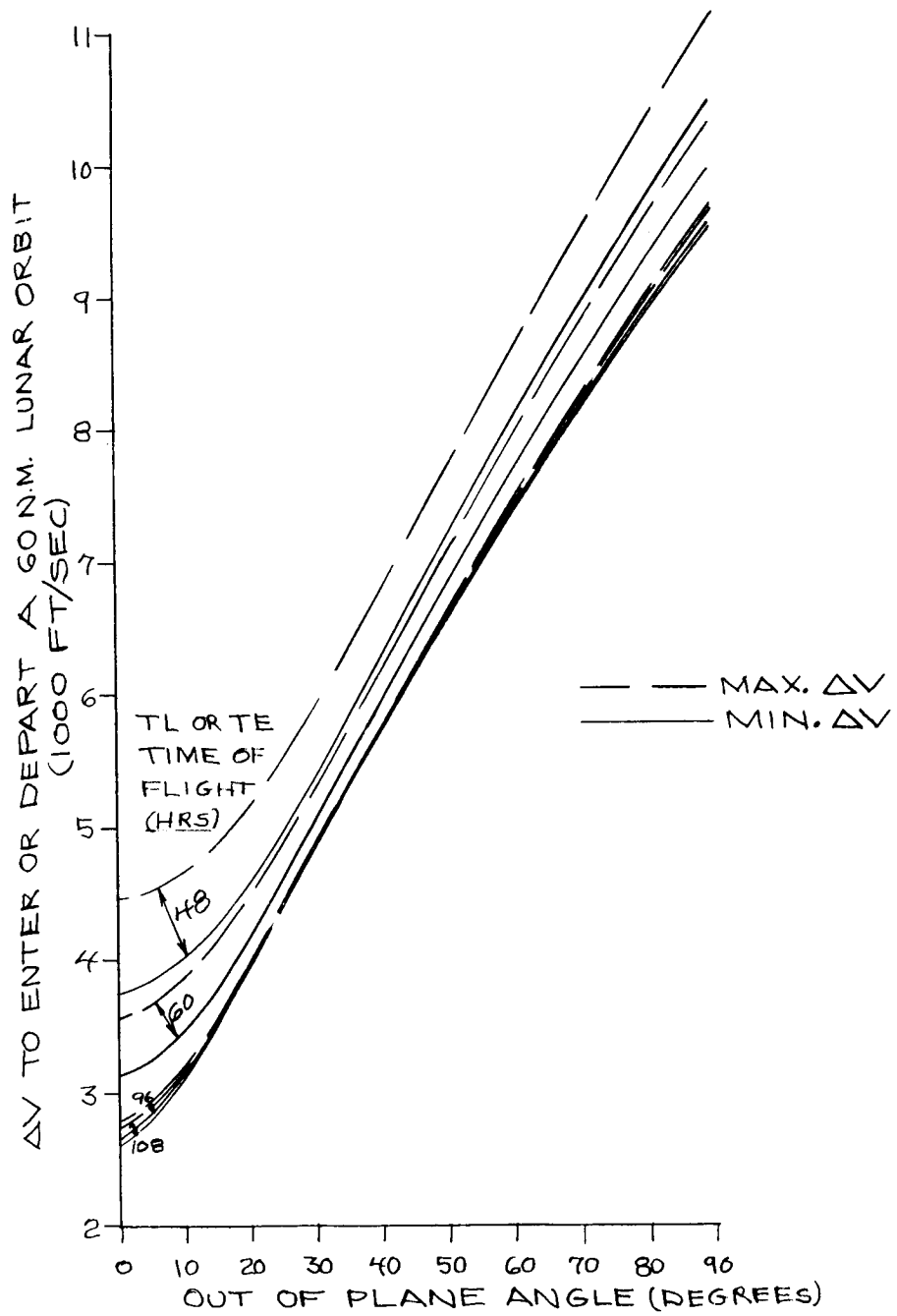

Fig. A-7 Optimum Single Impulse ΔV Requirement to Enter or Depart Lunar Orbit

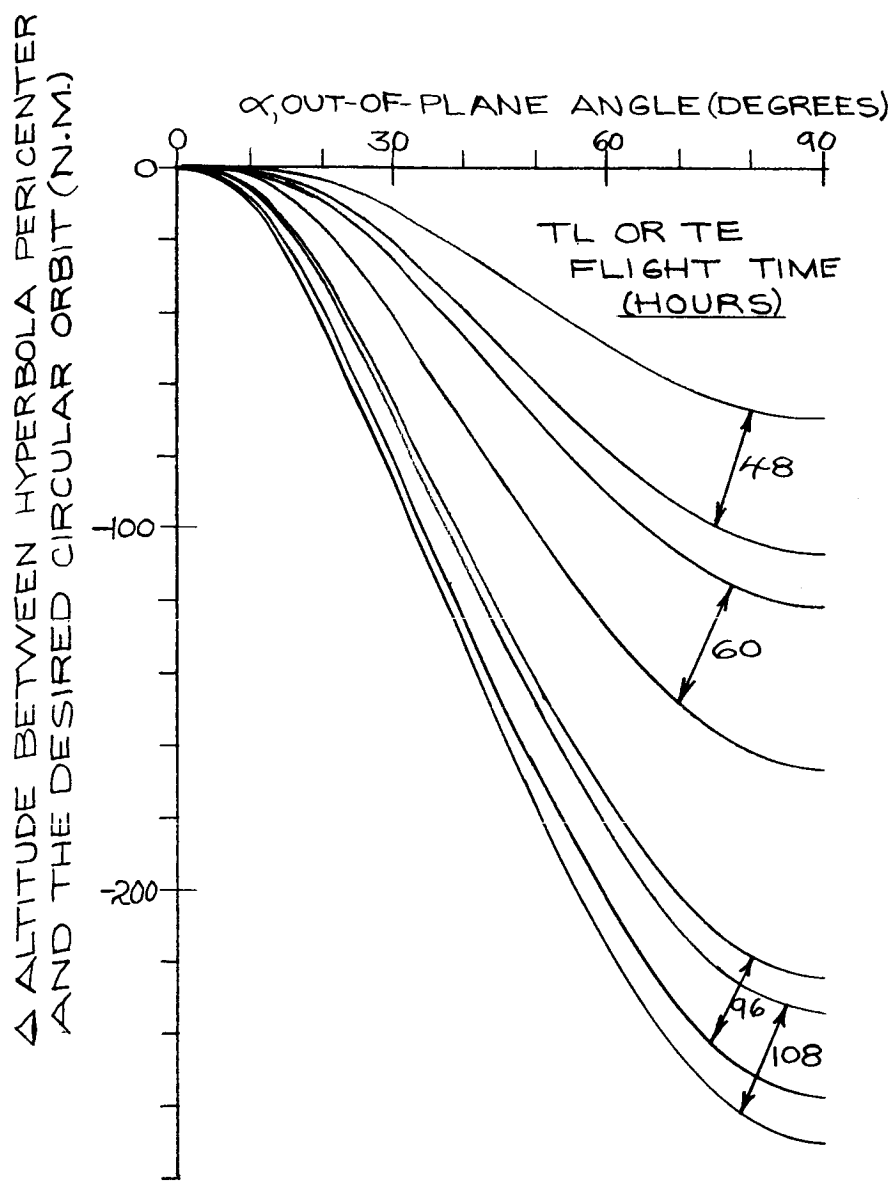

Fig. A-8 Δ Altitude for Optimum Single Impulse LOI or TEI

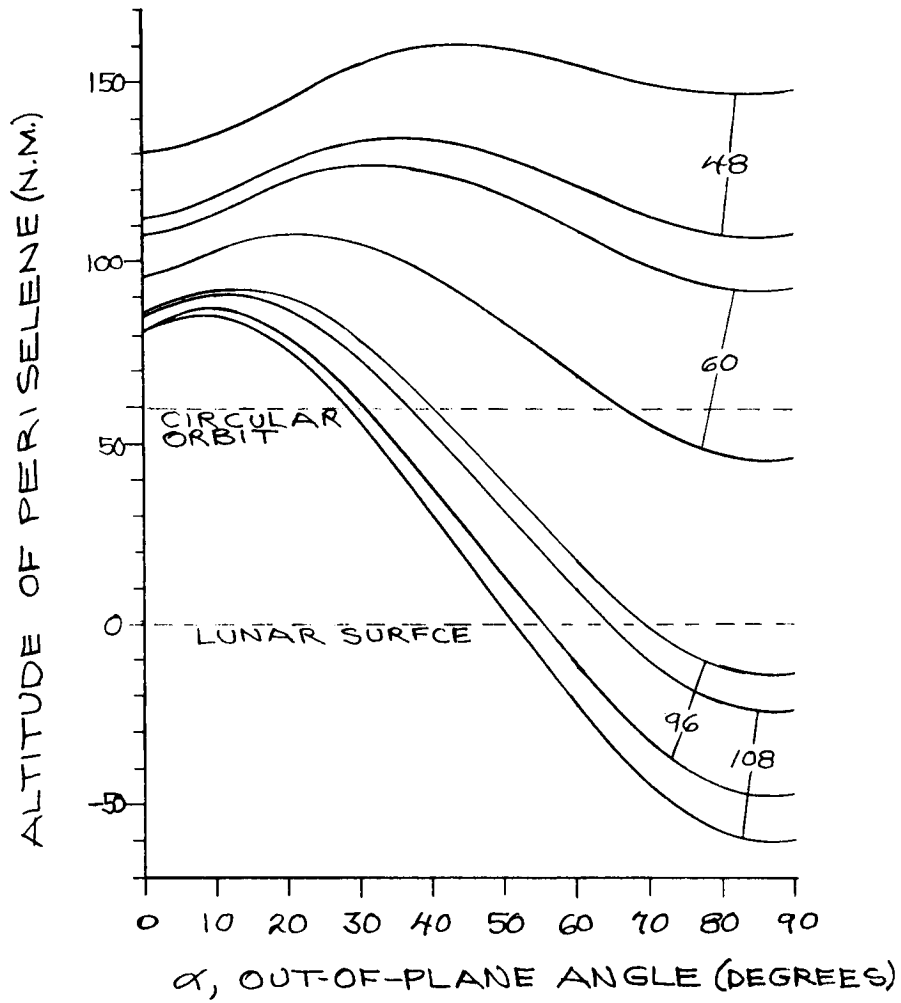

Fig. A-9 Required Target Altitude for Adjusted Hyperbola Pericenter for Optimum Single-Burn Insertion

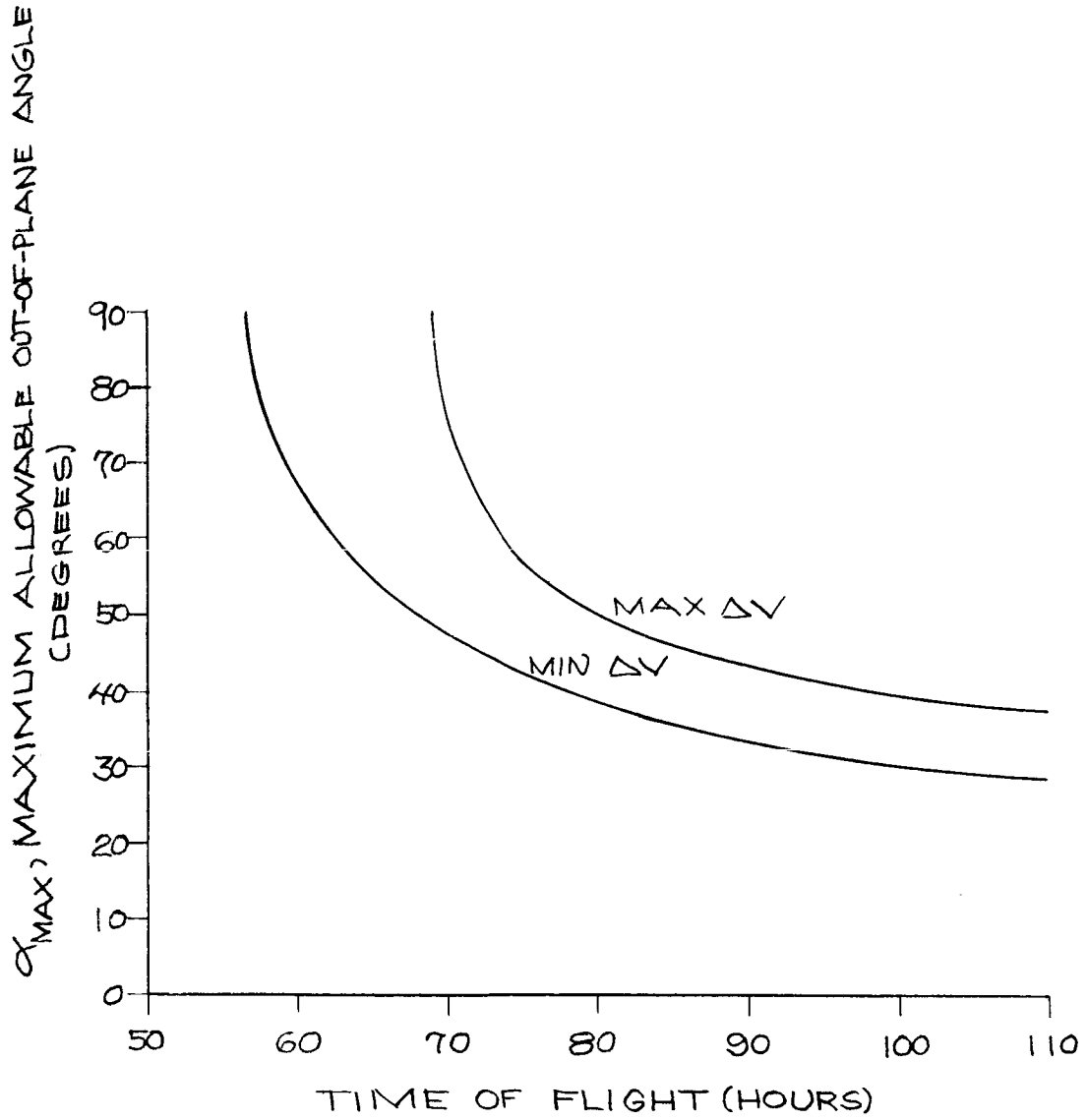

Fig. A-10 Maximum Plane Change for Constrained Periselene with Optimum Single Burn LOI

Trans-Earth Injection vs Lunar Orbit Injection

The previous pericenter constraints do not apply for trans-earth injection because the pericenter is behind on the trans-earth trajectory. Figure A-11 shows the velocity requirements vs out-of-plane angle for optimized single burn lunar departure and three burn departure using an intermediate ellipse. The departure curves are also good for lunar orbit injection if the previously mentioned constraints are removed. Another way of avoiding impact in the event of LOI burn is to perform the single burn at the pericenter of the approach hyperbola. The velocity requirements are shown as solid lines and are for an i_p of 60 degrees. However, by burning at the approach hyperbola half angle of the incoming asymptote whose ΔV is equal to the optimum, single burn, $\alpha = 90^\circ$ case.

Another method for lunar orbit insertion is the optimized two burn which provides an impulse just inside the Moon's sphere of influence plus a second burn at lunar orbit insertion. This approach has not been included in this write-up, but offers advantages over the single burn particularly for large out-of-plane angles. For an α of 90° , the two burn offers about a 40% reduction over the one burn, and the three burn provides another 20% decrease over the two-burn.

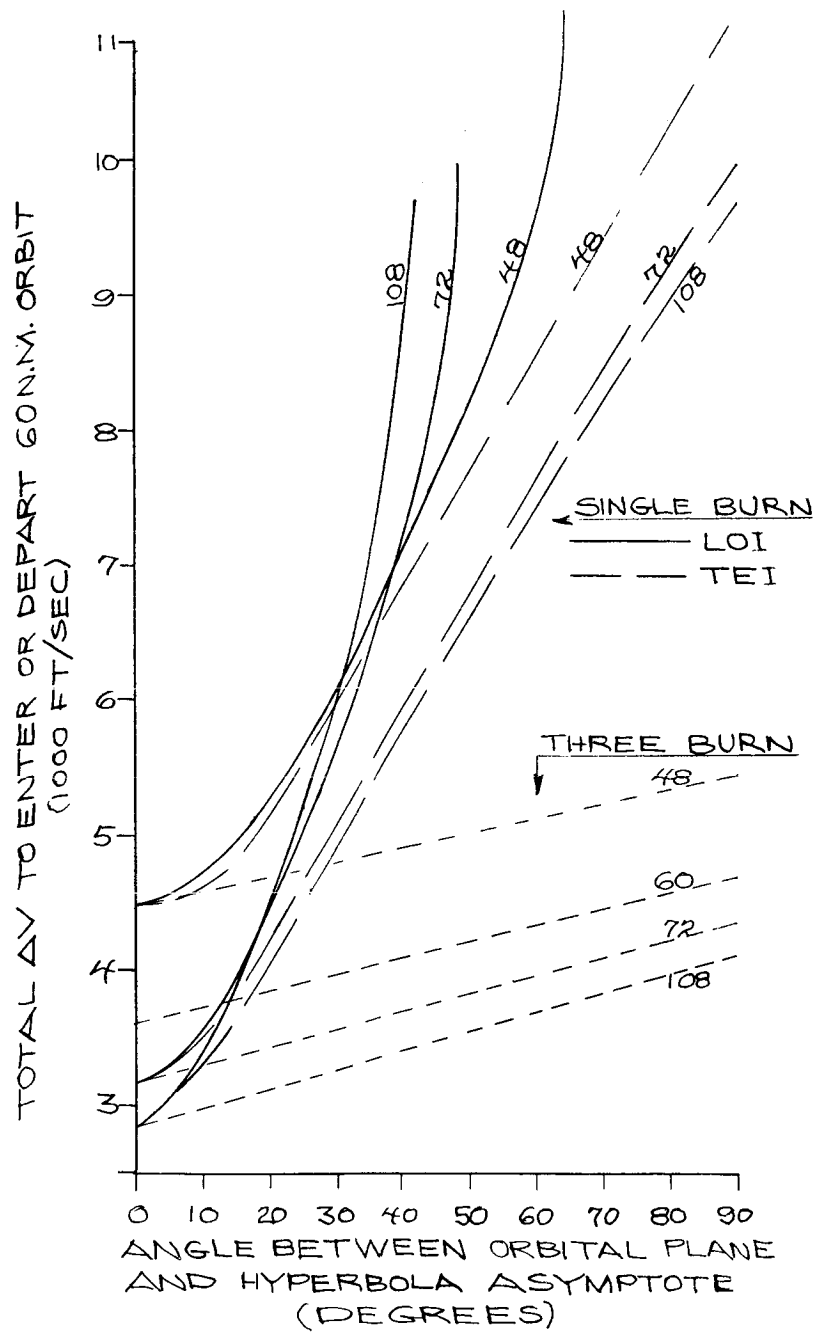

Fig. A-11 LOI or TEI Velocity Impulse

Lunar Surface Rescue Plane Change Requirements

The lunar surface rotates under the orbit track at a rate of 13.2 degrees of longitude per day. Consequently immediate descent to the rescue site may require up to a 90 degree plane change for a site on the lunar equator. The relation between plane change angle (α) and site latitude is shown as a function of time on Figure A-12 for a 90 degree polar orbit. Because of the continuous movement of a site into or out of the orbit track the plane change requirements for rescue descent and/or ascent must be based on the worst case.

The plane change requirements of various rescue based orbit inclinations for rescue from any place on the lunar surface are given in the following figures. The results are for one quadrant of the lunar surface but because of symmetry are applicable for the entire surface.

The definition and relation are shown on Figure A-13 for ascent from a site to an orbit. The results are equally valid for the descent case.

Polar Orbit

The results for polar orbit are given on Figure A-14 which gives the plane change angle (α) required as a function of longitude from the ascending node for various site latitudes. The longitude changes by 13.2 degrees per day due to the Moon rotation around its axis.

Equatorial Orbit

The lunar station equatorial orbit requirements are given on Figure A-15 which shows that for this orbit the plane change angle is equal to site latitude and is unaffected by the rotation of the lunar surface. Note that for a rescue site located any place except on the lunar equator a plane change will always be required.

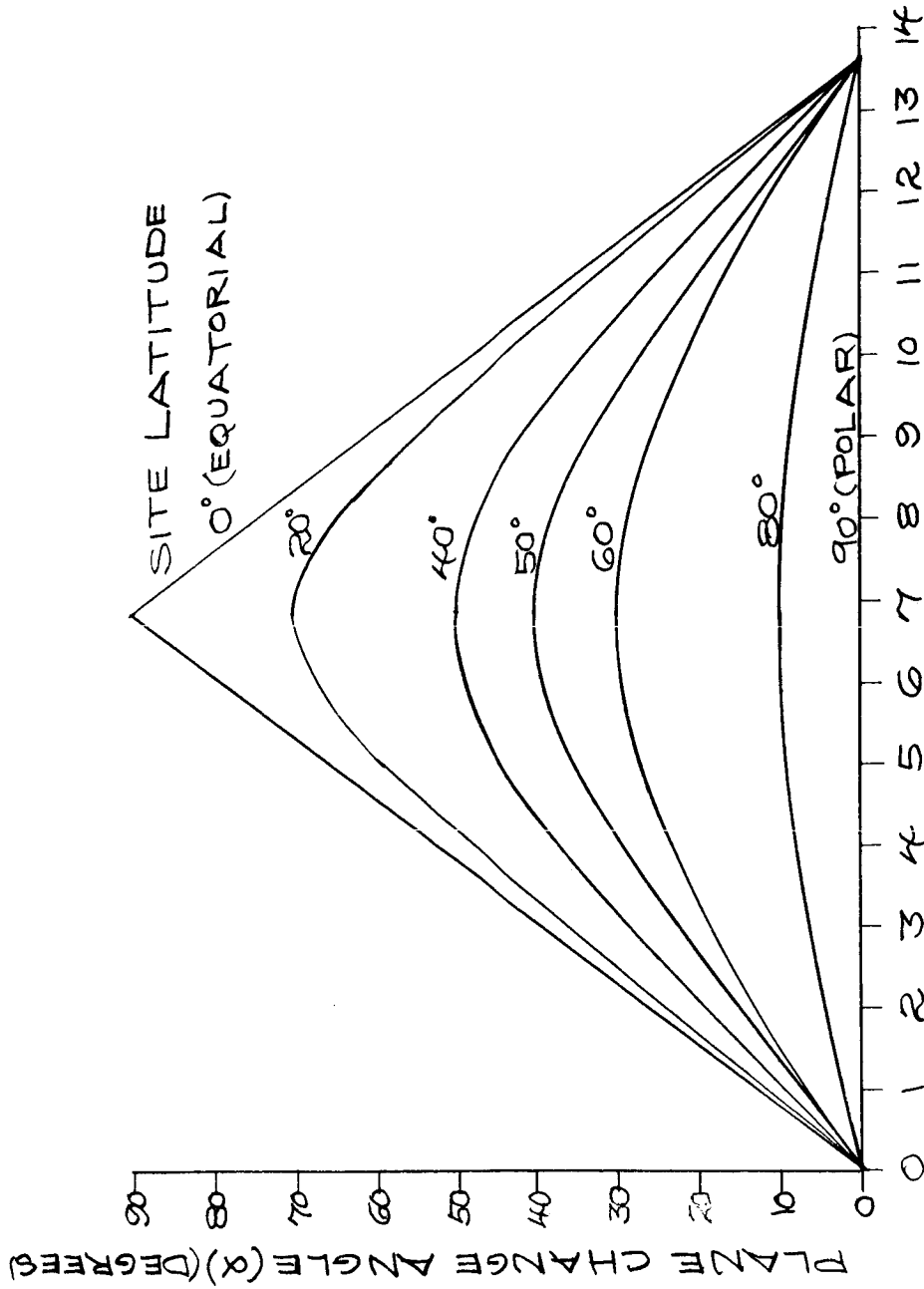
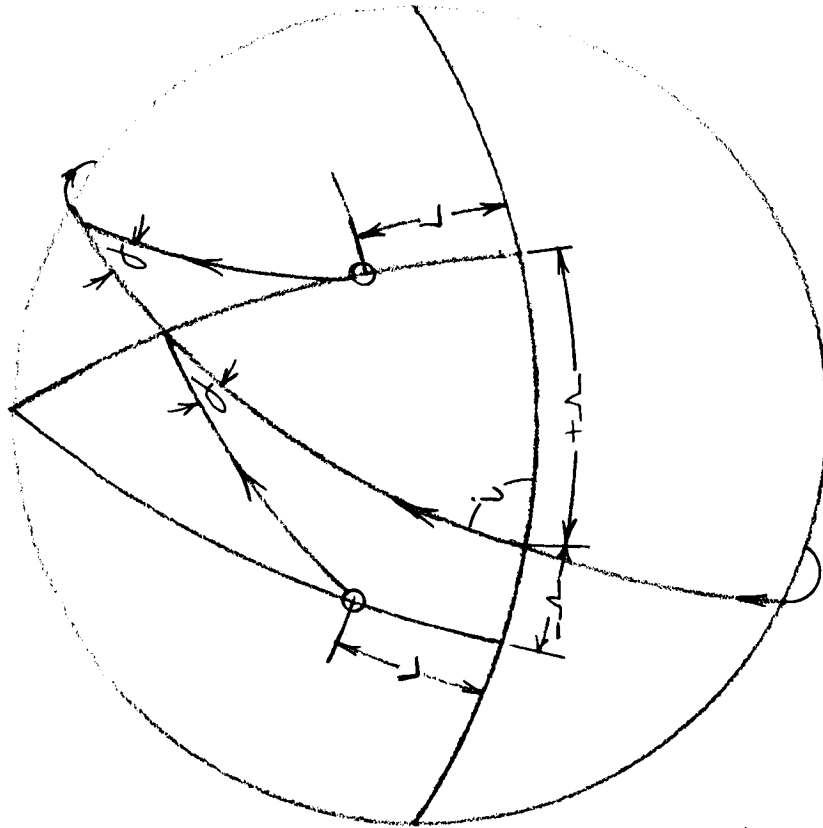

Fig. A-12 Plane Change Angle (α) vs Time for 90° Polar Orbit



- i = INCLINATION OF RESCUE ORBIT
- L = LATITUDE OF RESCUE SITE
- λ = DISTANCE IN LONGITUDE FROM A SCENDING NODE TO LONGITUDE OF RESCUE SITE
- α = PLANE CHANGE ANGLE REQUIRED FOR 90° ASCENT ARC

Fig. A-13 Orbit/Surface Geometry

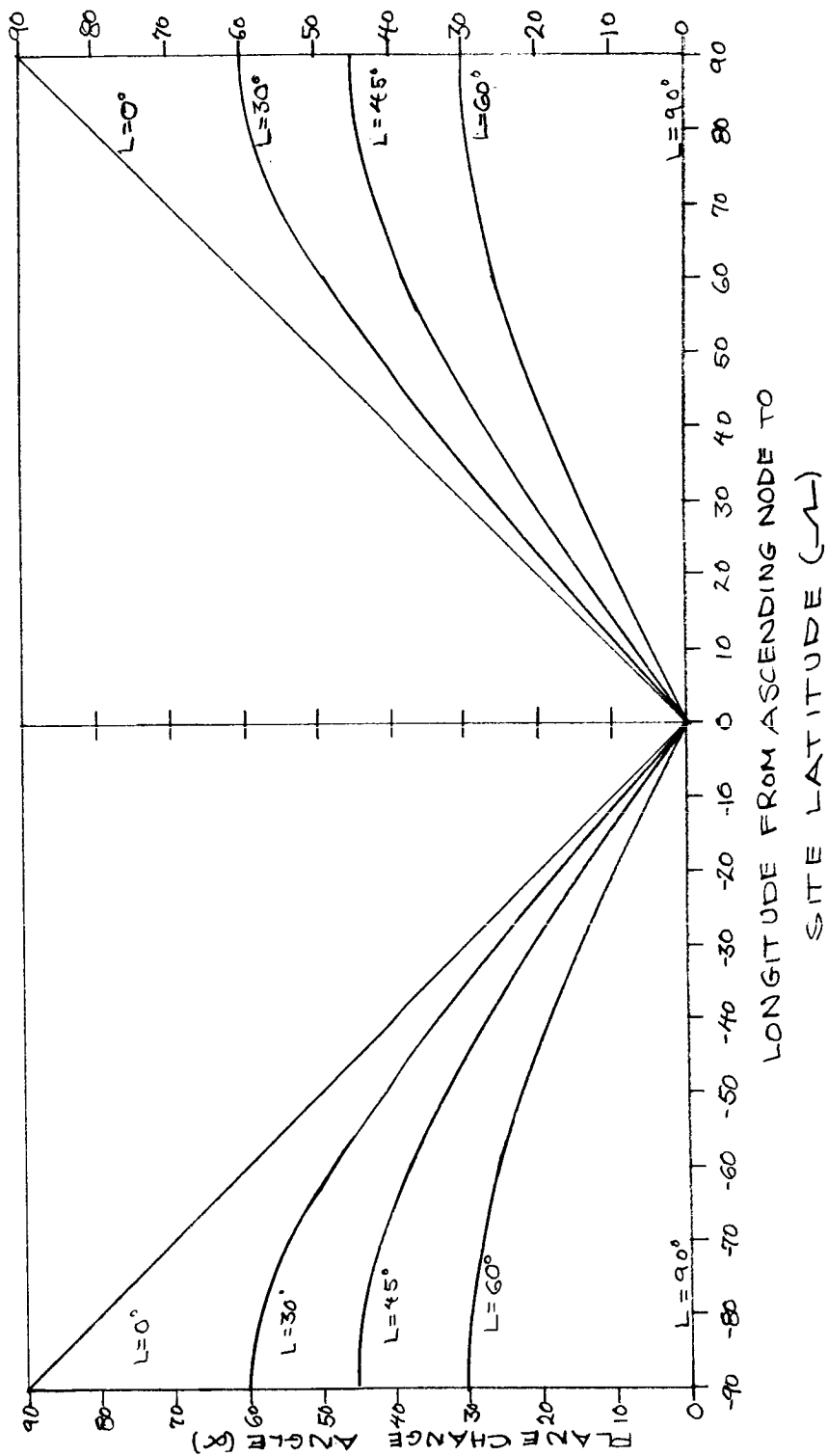

Fig. A-14 Plane Change Angle (α) vs Longitude (λ) for Constant Site Latitude (L) at Inclination (i) = 90° (Polar)

Fig. A-14

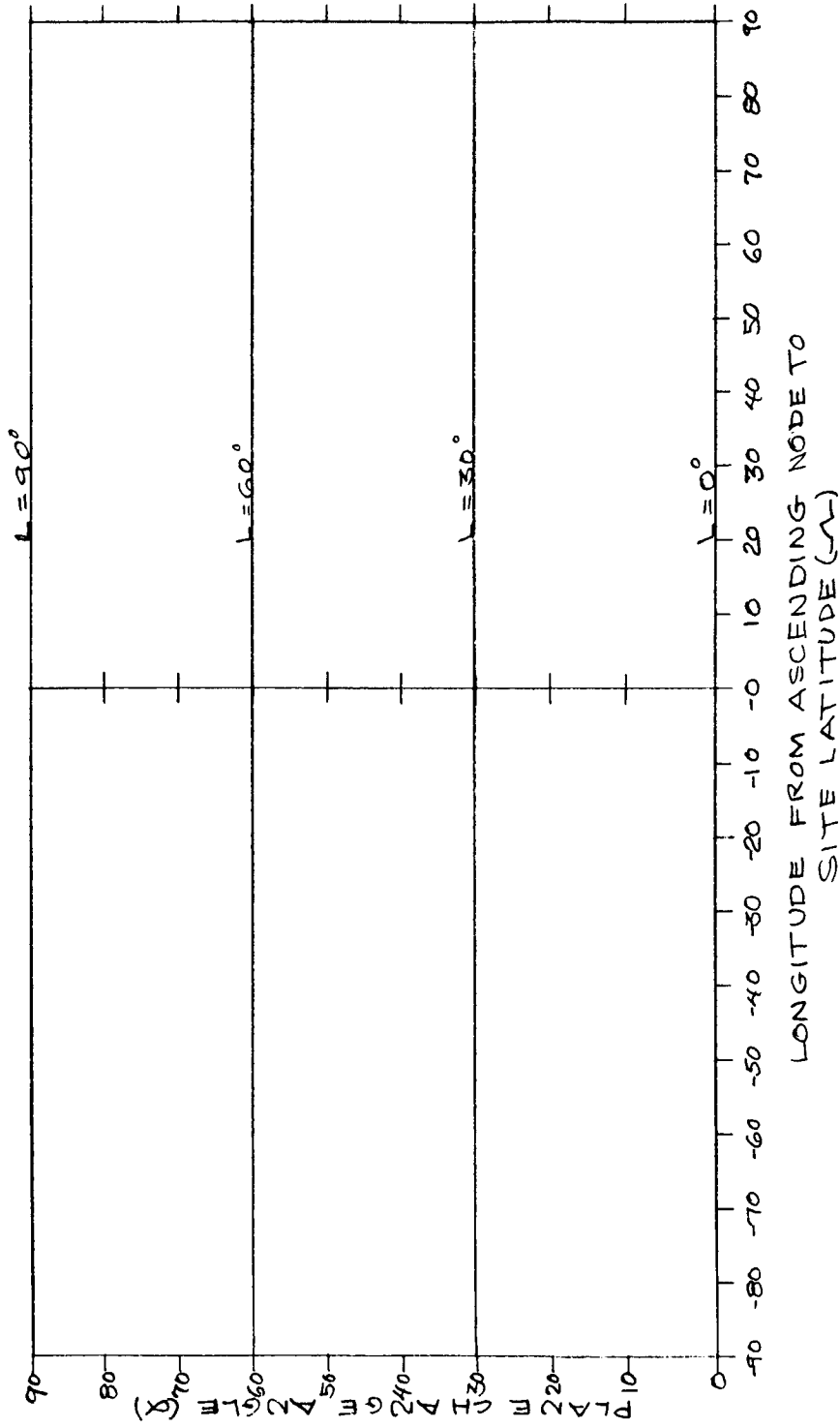

Fig. A-15 Plane Change Angle (α) vs Longitude (λ) for Constant Site Latitude (L) at Inclination (i) = 0° (Equatorial)

45 Degree Orbit

The results for an inclination of 45 degrees are given on Figure A-16 which shows that as long as the site is to the right of the ascending node the maximum plane change angle is 45 degrees for any latitude. However, when the site is to the left, the angle goes to 90 degrees for the extreme case of $\lambda = -90^\circ$. As mentioned previously, λ increases by 13.2 degrees, so that by waiting a maximum of seven (7) days the plane change angle can be held to 45 degrees or less for any latitude.

Maximum Plane Change Angles

The results of the previous charts have shown that worst case (maximum α) occurs at $\pm \lambda = 90^\circ$. The maximum plane change angle is given as a function of site latitude and inclination on Figure A-17 for the $\lambda = \pm 90^\circ$ case. Examination shows that by restricting site latitudes for a particular orbit the maximum plane change angle that must be provided for can be reduced.

Limited Plane Change Capability

If the available plane change capability is less than 90 degrees, the options available are presented on Figure A-18. For $\alpha = 90^\circ$, ascent from any latitude to any inclination is possible without delay. The permissible combinations are also given for $\alpha = 30^\circ$ and 60° . Because the relations are all straight lines, the allowable areas can be easily drawn in for any other plane change capability.

Descent Case

The previous figures were based on analysis of ascending from a surface site to rendezvous with an orbiting station without any delay in launch except for phasing and to insure the vehicles were coplanar and their velocity vectors in the same direction. The results are equally valid for the descent case

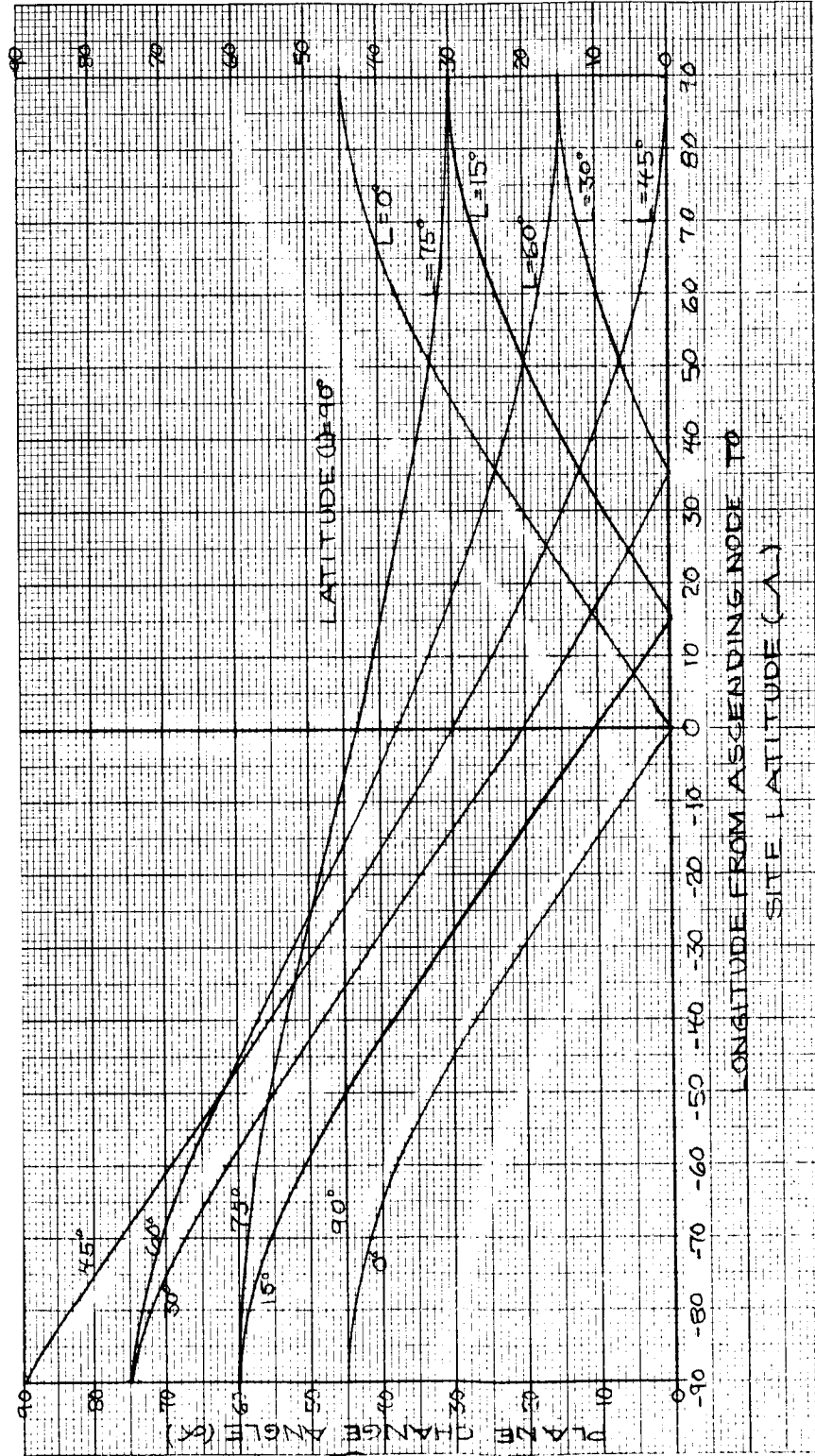

Fig. A-16 Plane Change Angle (α) vs Longitude (λ) for Constant Site Latitude (L) at Inclination (i) = 45°

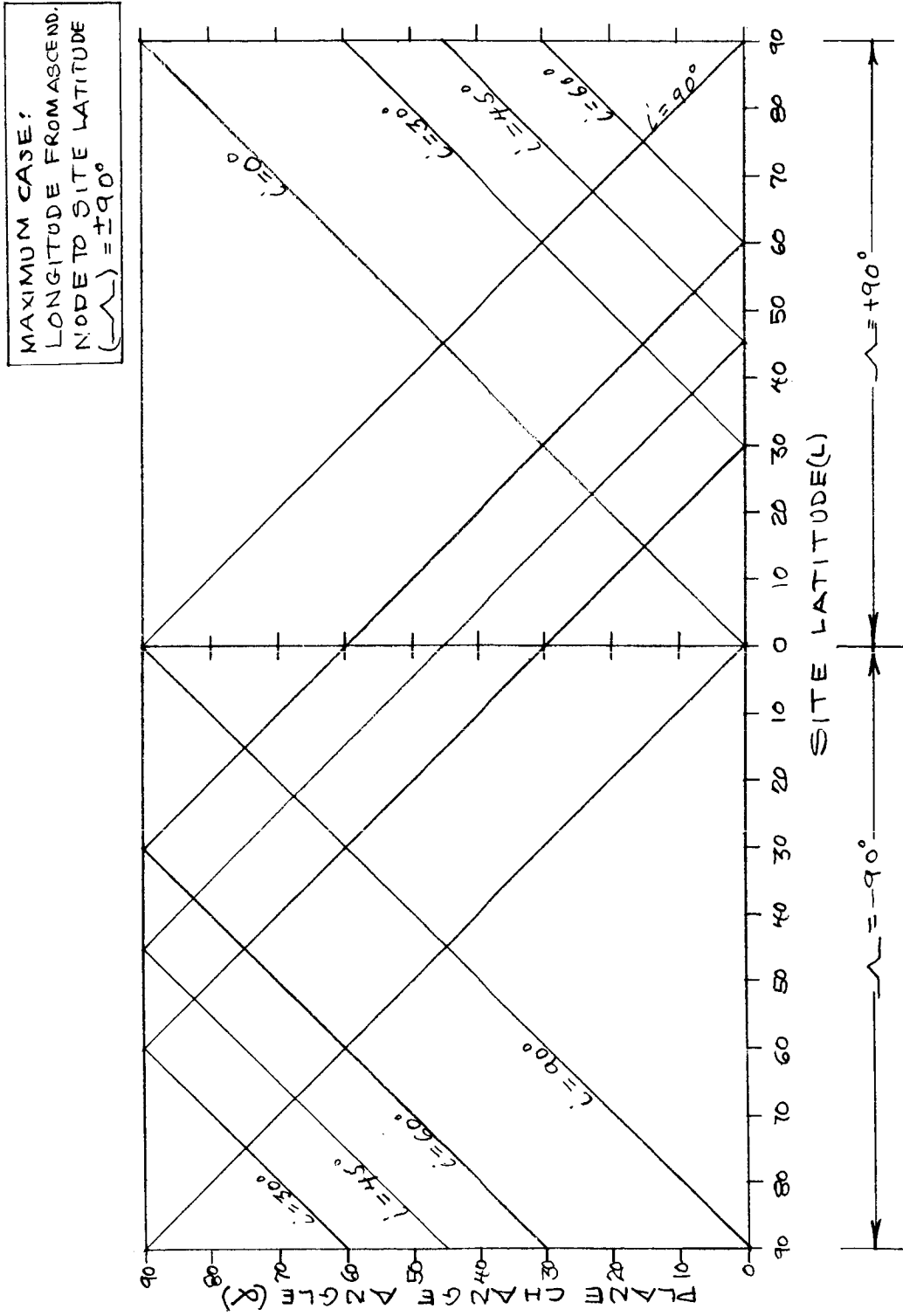

Fig. A-17 Maximum Plane Change Angle (α) vs Site Latitude (L)

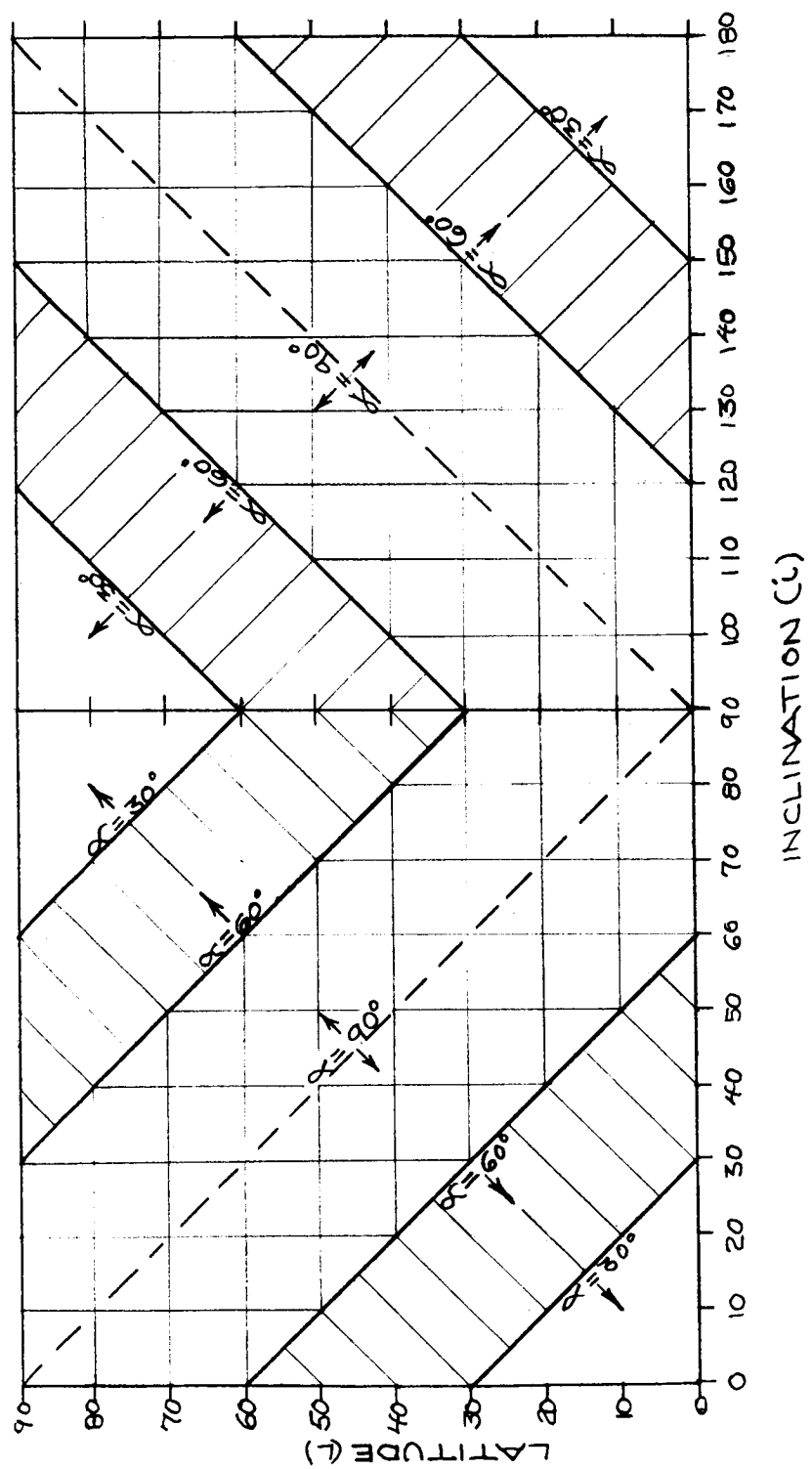

Fig. A-18 Available Latitudes (L) vs Inclination (i) as a Function of Maximum Plane Change Angle (α) for Longitude from Ascending Node (λ) = $\pm 90^\circ$

except that in Figure A-13 the directions are reversed and are referenced to the descending node of the orbit. A 90 degree range angle is used from site to plane change point for both ascent and descent to minimize the plane change angle.

Time Considerations

Considerations of surface stay time or delay between descent and ascent have not been included. For example, if $\lambda = -90^\circ$ (worst case) at descent and the ascent is delayed for two days due to surface rescue operations, the ascent case would be $90^\circ - 26.4^\circ = 63.6^\circ$. In addition, phasing for descent and ascent have not been included which could be a maximum of two hours for each.

Velocity Requirements for Descent

The requirements for the following four types of descent trajectories have been defined in terms of ΔV and time:

1. Two-Burn Co-Planar
2. Three-Burn Plane Change
3. Four-Burn Elliptical
4. Five-Burn Elliptical

Two Burn Co-Planar Descent

The two-burn co-planar trajectory is shown on Figure A-19 using a modified Apollo landing technique. A descent ellipse from 60 n.m. to 50,000 feet of approximately 180° is followed by a powered descent to the surface from 50,000 feet. The total time of 3.1 hours is broken down as follows:

Phasing Orbit	2 hours
Descent	.9 hours
Powered Descent	<u>.2</u> hours
	3.1 hours

The total ΔV budget of 7400 ft/sec for the descent and landing based on Apollo experience.

The results presented in this analysis are addressed to the question of minimum times for rescue and it should be noted that no specific time has been allotted for navigation and guidance updating and the correction of dispersions.

Three-Burn Plane Change

If the orbit plane must be changed in order to be co-planar with the landing site, two methods are available, three-burn and elliptical transfer.

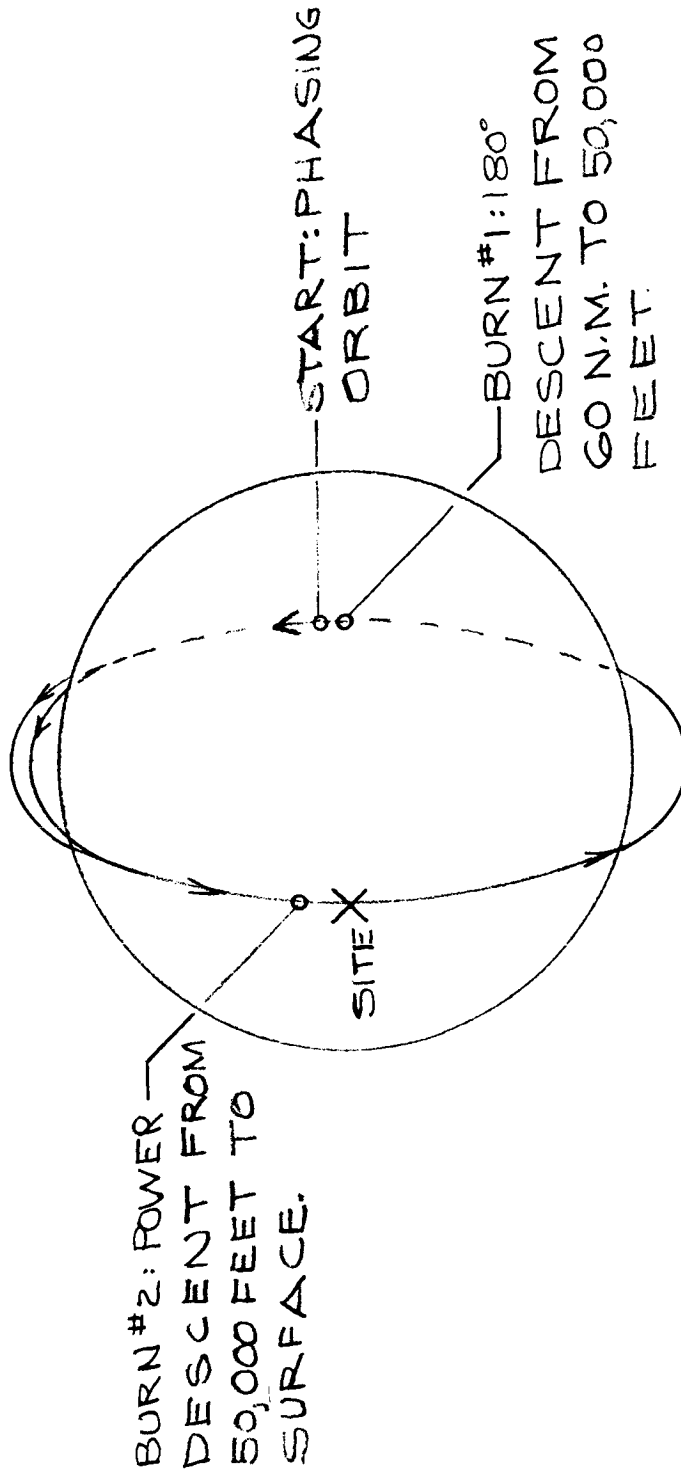

TIME: 1 1/2 PERIODS \approx 3.1 HOURS
 $\Delta V = 7400$ FT/SEC.

Fig. A-19 Two-Burn Co-Planar Descent

(For the three-burn case a straight plane change of angle (α) is made at a range angle of 90° from the site as shown on Figure A-20. The 90° range angle provides the minimum (α) to become co-planar. The additional ΔV to be added directly to the basic 7400 ft/sec is determined according to the equation:

$$\Delta V_\alpha = 2V \sin \frac{\alpha}{2}$$

where V is the velocity at plane change.

For a 60 n.m. lunar orbit the circular velocity is 5340 feet.

Elliptical Transfers

The four and five burn elliptical descents take advantage of the velocity factor by transferring to a highly elliptical orbit and performing the plane change at the apolune where the velocity is reduced by:

$$\frac{V_A}{V_C} = \frac{R_C}{R_A} \sqrt{\frac{2}{1 + \frac{R_C}{R_A}}}$$

Where: subscript C is for 60 n.m. circular and A is apolune conditions

or almost directly to the inverse of the ratio R_A/R_C . The term under the radical increases V_A/V_C slightly.

The period, however, increases with an increase in the ratio of R_A/R_C as:

$$\frac{P_A}{P_C} = \left(\frac{\frac{R_A}{R_C} + 1}{2} \right)^{3/2}$$

The decrease in velocity and increase in period as a function of R_A/R_C are plotted on Figure A-21 for the range of values considered in this study.

Optimum vs. R_A/R_C

For each value of plane change angle (α) there is an optimum tradeoff between the ΔV saved in the plane change and the extra ΔV required to enter and exit the intermediate ellipse. The results of this tradeoff are shown on Figure A-22 as a function of R_A/R_C .

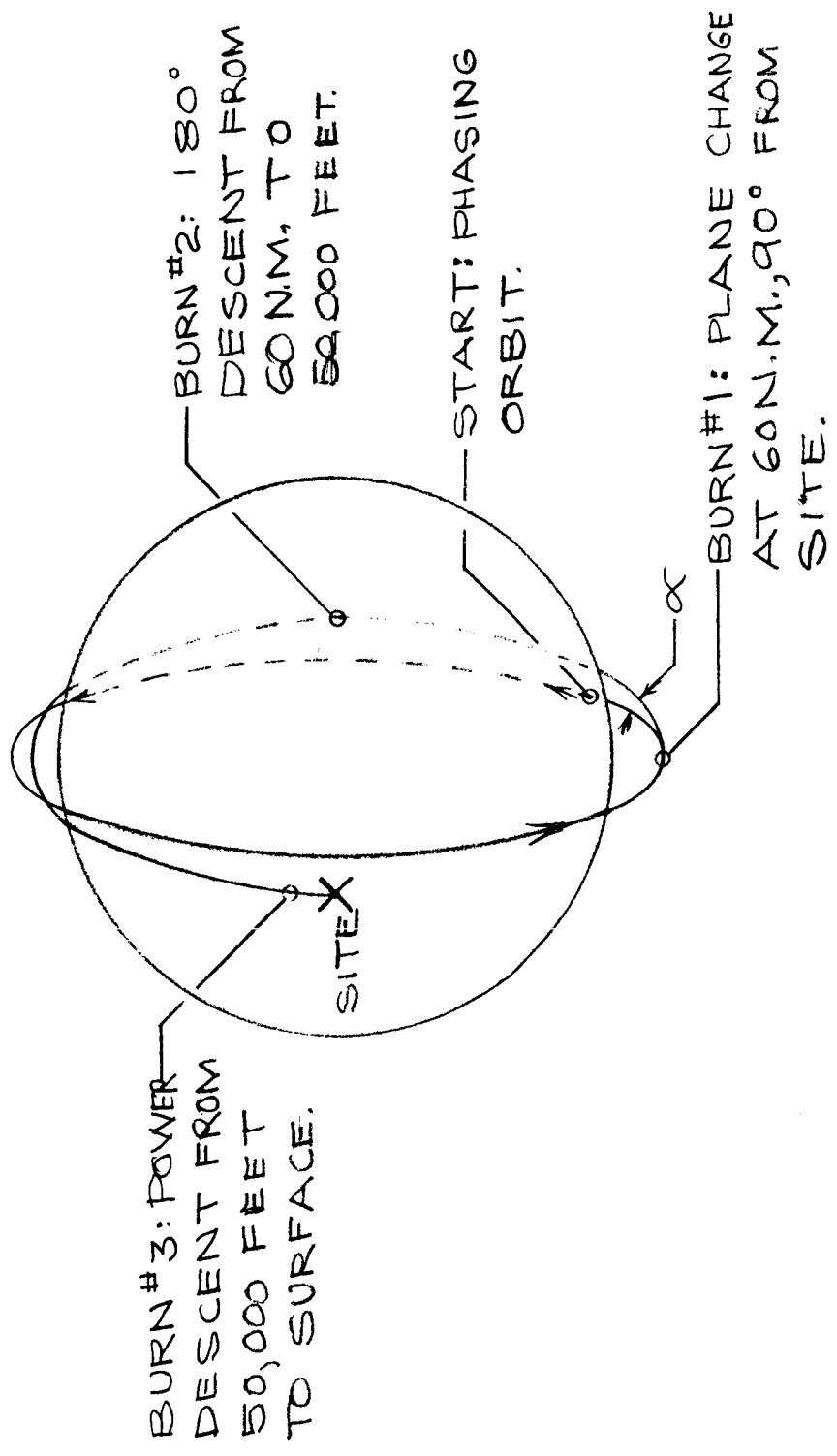

TIME: 1 3/4 PERIODS ≈ 3.6 HOURS

Fig. A-20 Three-Burn Descent

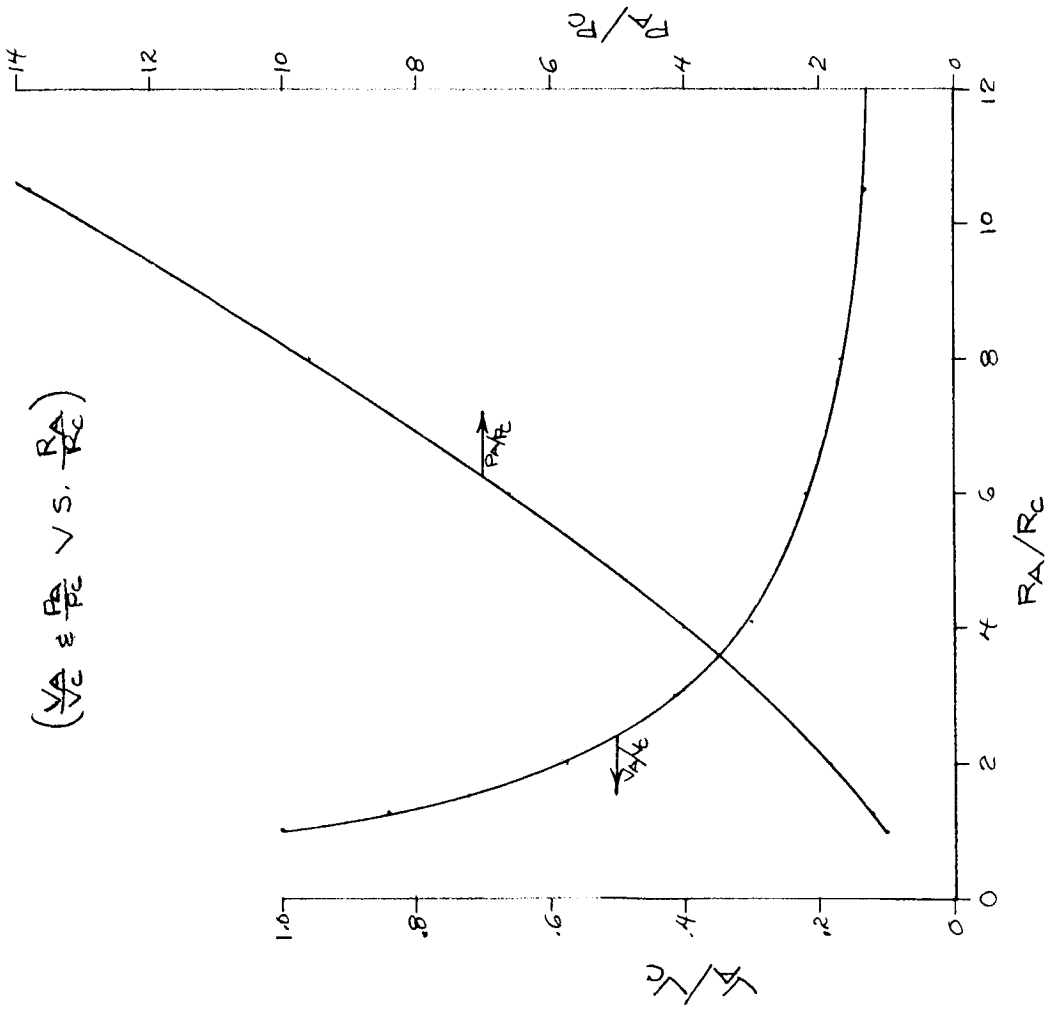

Fig. A-21 Velocity Decrease & Period Increase vs Ratio of Circular Radius to Elliptical Radius

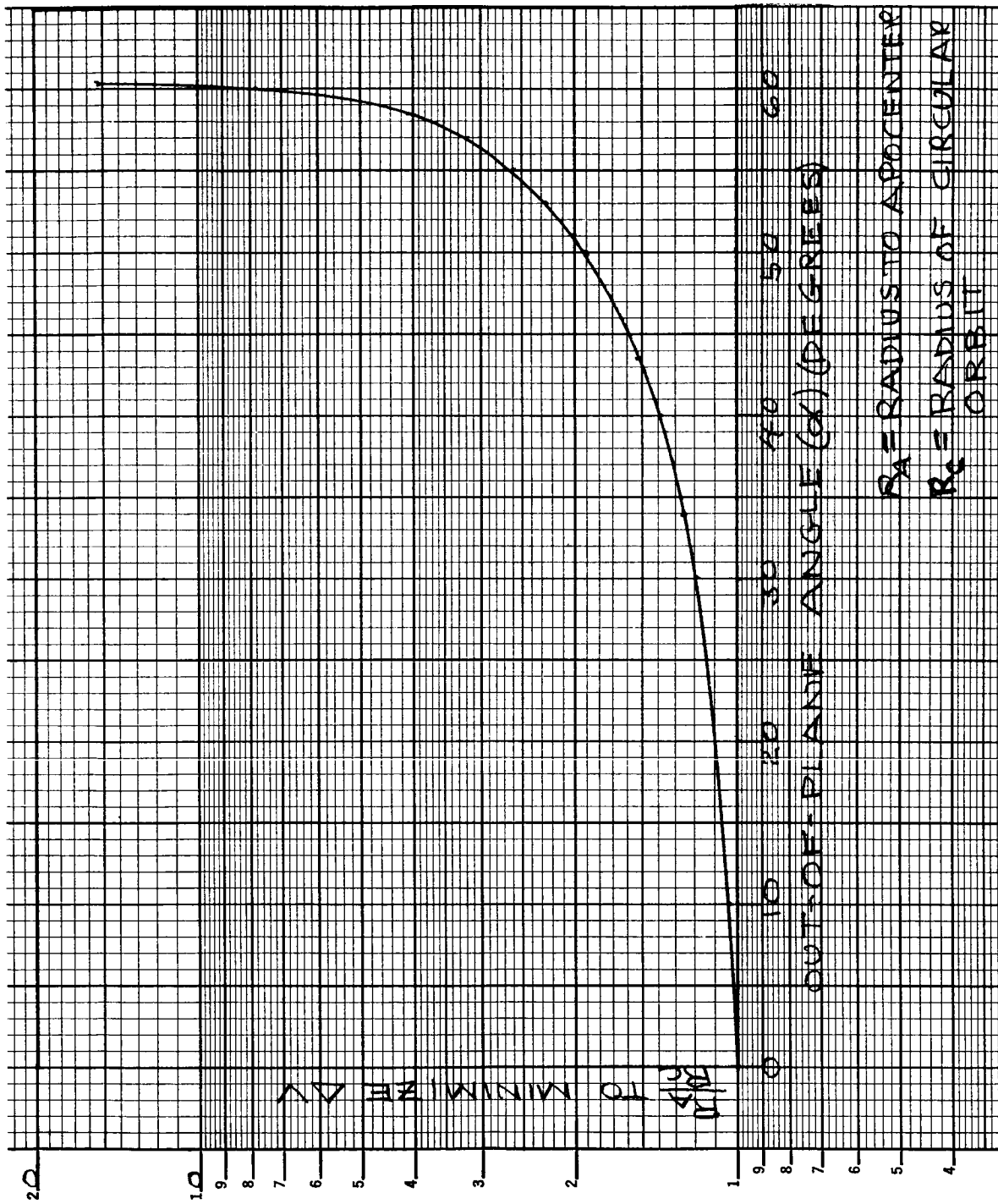

Fig. A-22 Optimum Apocenter Radius for Plane Change Intermediate Ellipse

Four-Burn Elliptical Descent

The technique for taking advantage of the elliptical transfer orbit is shown on Figure A-23. The major part of the plane change is made at apolune, but computer runs were made to optimize the first three burns to provide minimum ΔV . The results are shown on Figure A-24 as a function of (α). The solid line with its corresponding time is actually the limit of the four-burn case with $R_A/R_C = 1.0$.

The results of Figure A-24 are cross plotted on Figure A-25 to show the trade-off between delta V and descent time. The curves for 30° , 50° , and 60° are terminated at the optimum value of R_A/R_C (Figure A-22). Beyond that point ΔV starts to increase as time increases.

Five-Burn Elliptical Descent

A difficult part of the four-burn sequence is burn #2 for large ellipses where the periselene of the transfer ellipse must be adjusted from 60 n.m. to 50,000 feet. This combination is made to reduce total descent time. A more conservative sequence is shown on Figure A-26 where an extra 180° is used to transfer from 60 n.m. to 50,000 foot orbit. The ΔV requirements are essentially the same as for the four-burn case (Figures A-24 and A-25), but the times are increased by one hour.

Short-Arc Descent

A 180° transfer is normally used from 60 n.m. to 50,000 feet to minimize ΔV .

In addition, the 180° transfer results in a trajectory whose periselene is still at 50,000 feet which provides a safe orbit if the second burn does not occur. By using a shorter arc, the transfer time can be reduced from approximately one hour at an increase in ΔV . In addition,

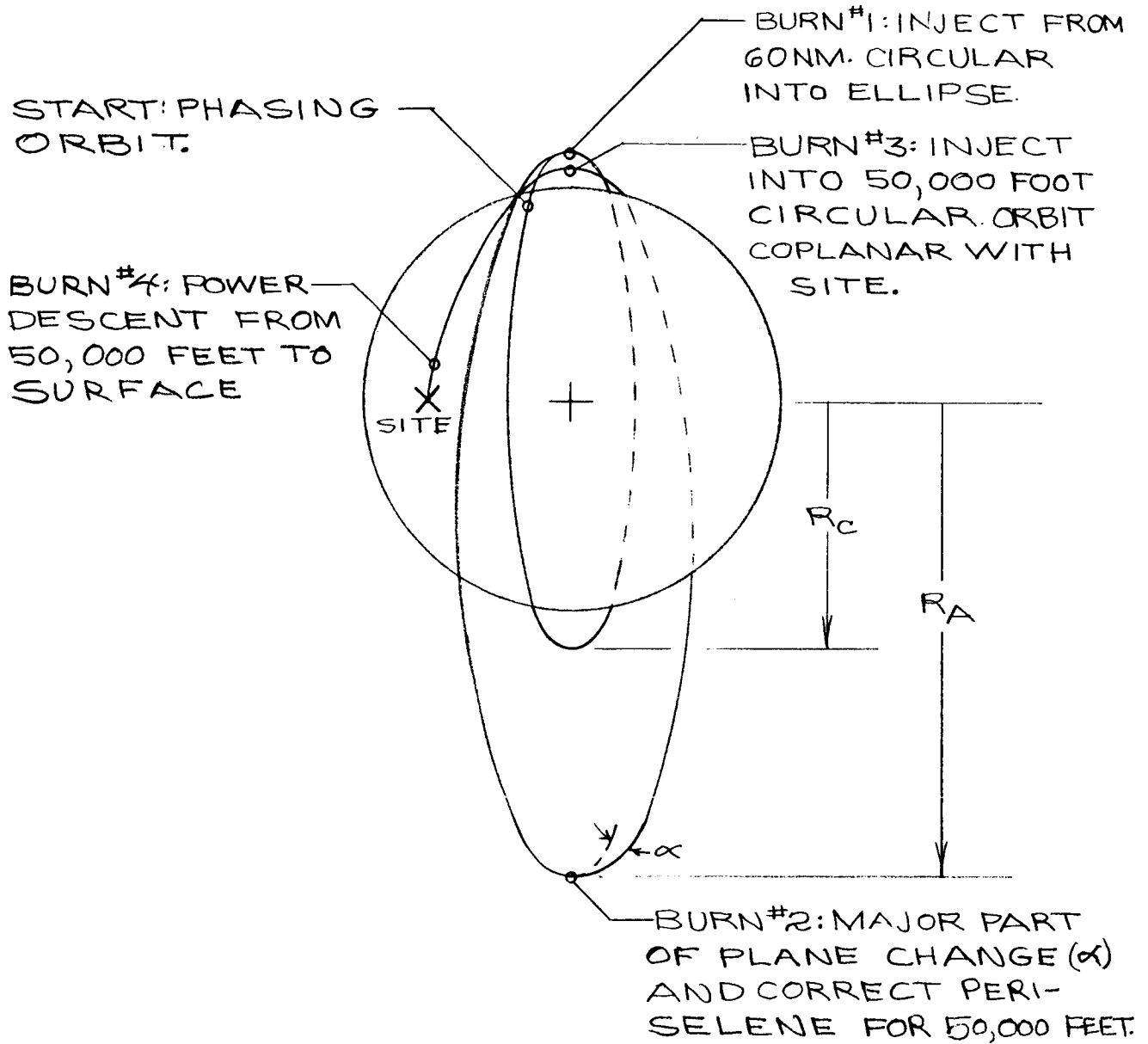

FOUR-BURN DESCENT
 TIME: 4.6 HOURS FOR $R_A/R_C \rightarrow 1.0$

Fig. A-23

Four-Burn Descent

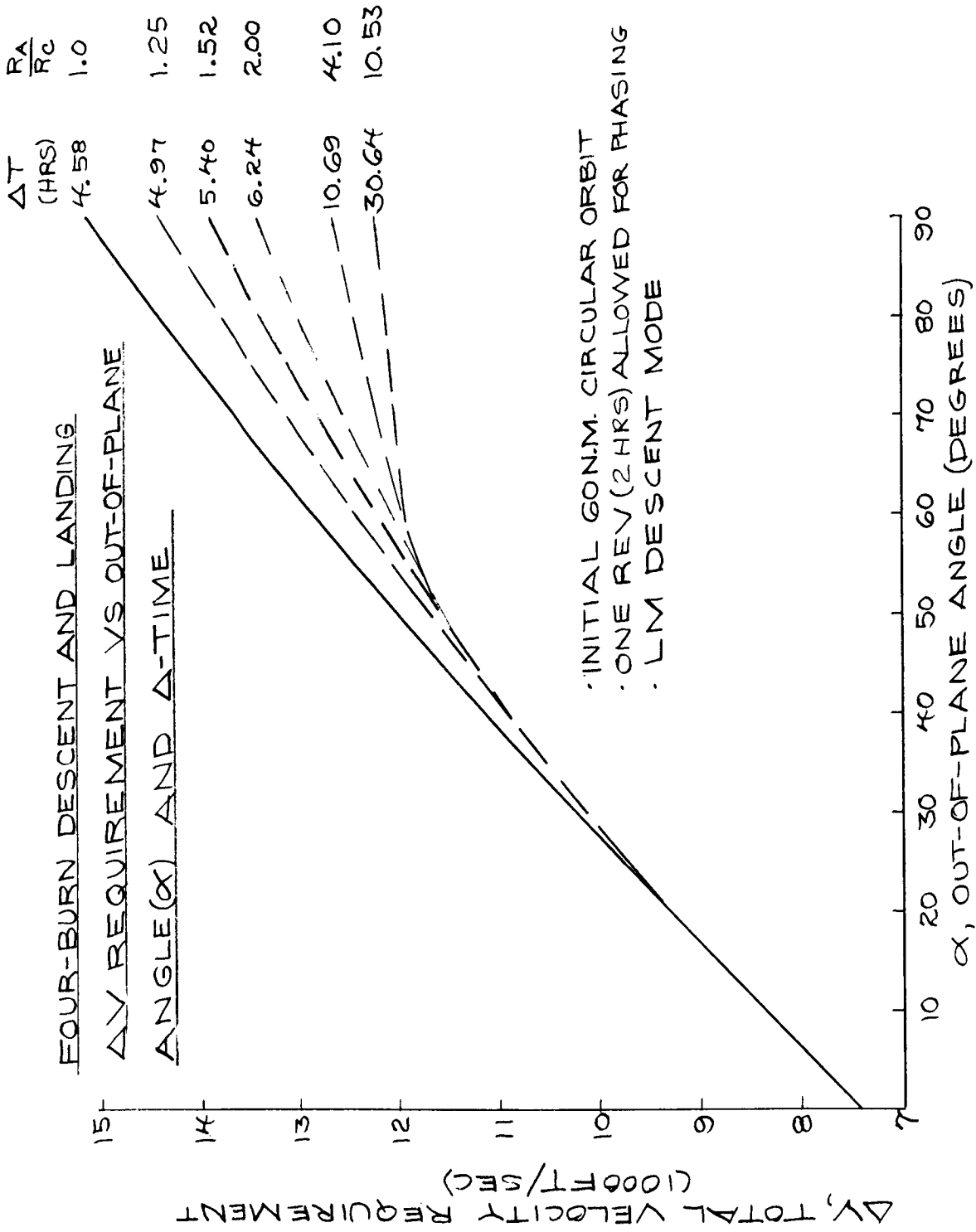

Fig. A-24 Four-Burn Descent and Landing ΔV vs α

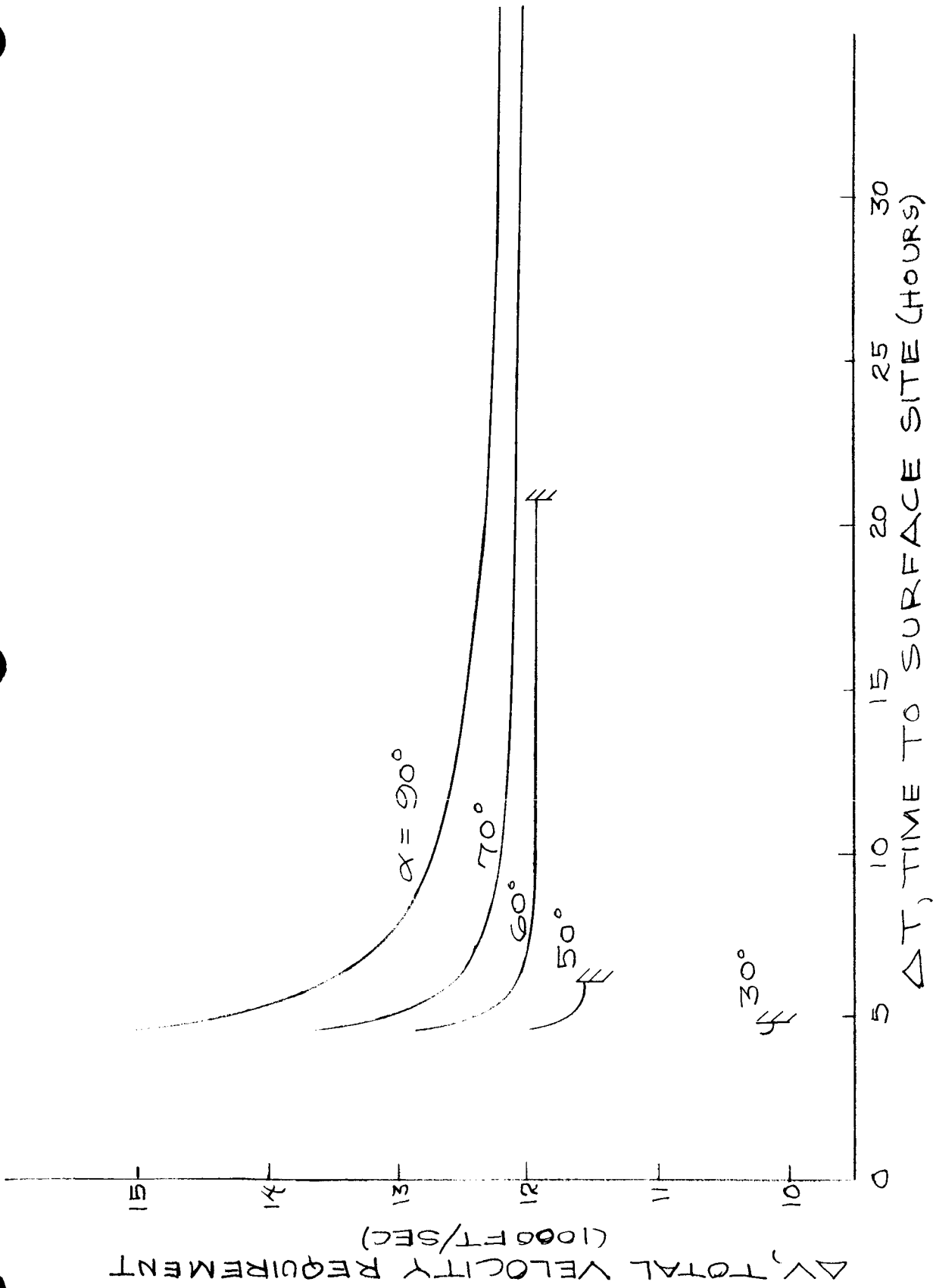
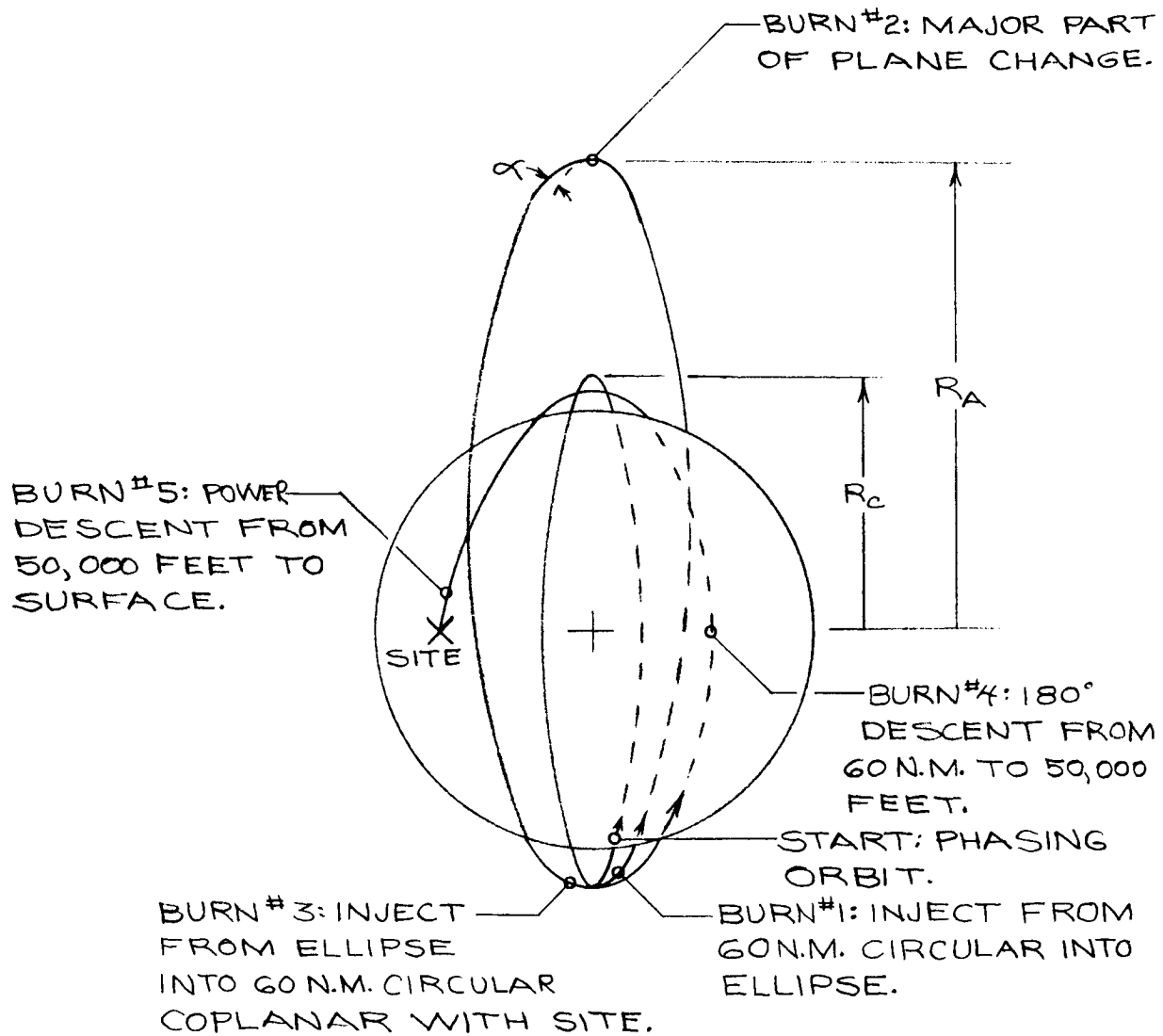

Fig. A-25 Four-Burn Descent and Landing ΔV vs ΔT



FIVE-BURN DESCENT

TIME: 5.6 HOURS FOR $R_A/R_c \rightarrow 1.0$

Fig. A-26 Five-Burn Descent

the periselene of the transfer trajectory goes to negative altitude, thereby placing the vehicle on an impact trajectory. Figure A-27 provides the ΔV requirement for shortening the descent time. It approaches an asymptote of 2.2 hours which includes one period for phasing. The normal descent would be 180 degrees (approximately one hour) plus descent from 50,000 feet (0.1 hour) and one period (2 hours) for phasing for a total of 3.1 hours. Figure A-27 does not include any plane change requirements which must be made a range angle of 90 degrees from the site in order to minimize (α) and consequently ΔV .

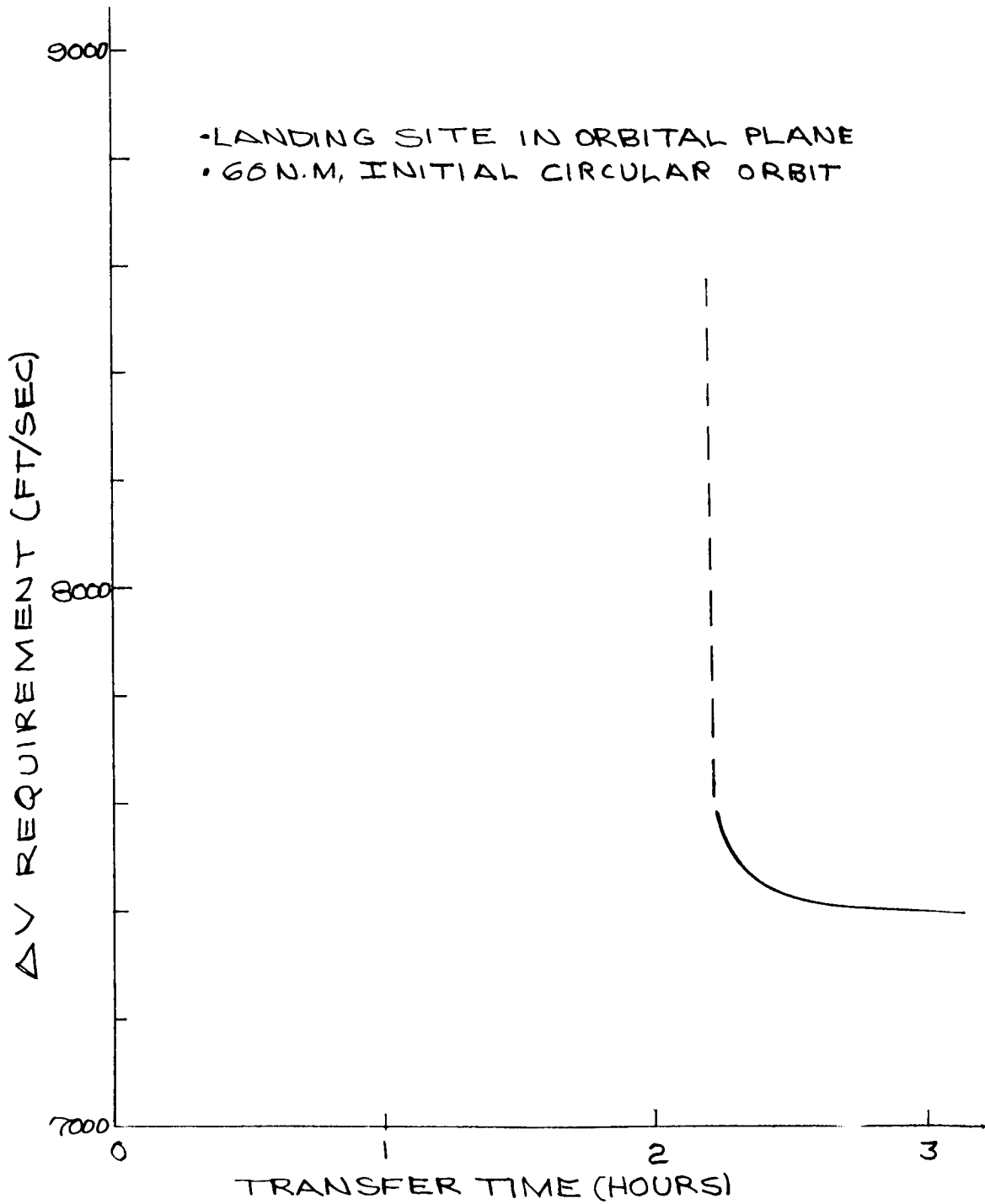

Fig. A-27 Short Arc Descent and Landing ΔV Requirement

Ascent and Rendezvous Requirements

The basic ascent sequence is shown on Figure A-28. The three-burn sequence is used whether a plane change is required or not. The basic time requirement is 4.9 hours and a ΔV budget of 6,600 ft/sec. These budgets include phasing time on the ground before launch of 2.0 hours and a final rendezvous sequence of 1.2 hours.

As in the descent case ΔV for plane changes may be traded for time by using the transfer ellipse method requiring five burns as shown on Figure A-29. The computer optimization results are shown on Figures A-30 and A-31 for the ascent case, the solid line is the limit of the five-burn case. The times include:

Phasing	2.0 hours
Ascent & Coast	.7 hours
Intermediate ellipse	2.0 + hours
Final Rendezvous	<u>1.2 hours</u>
	5.9 hours +

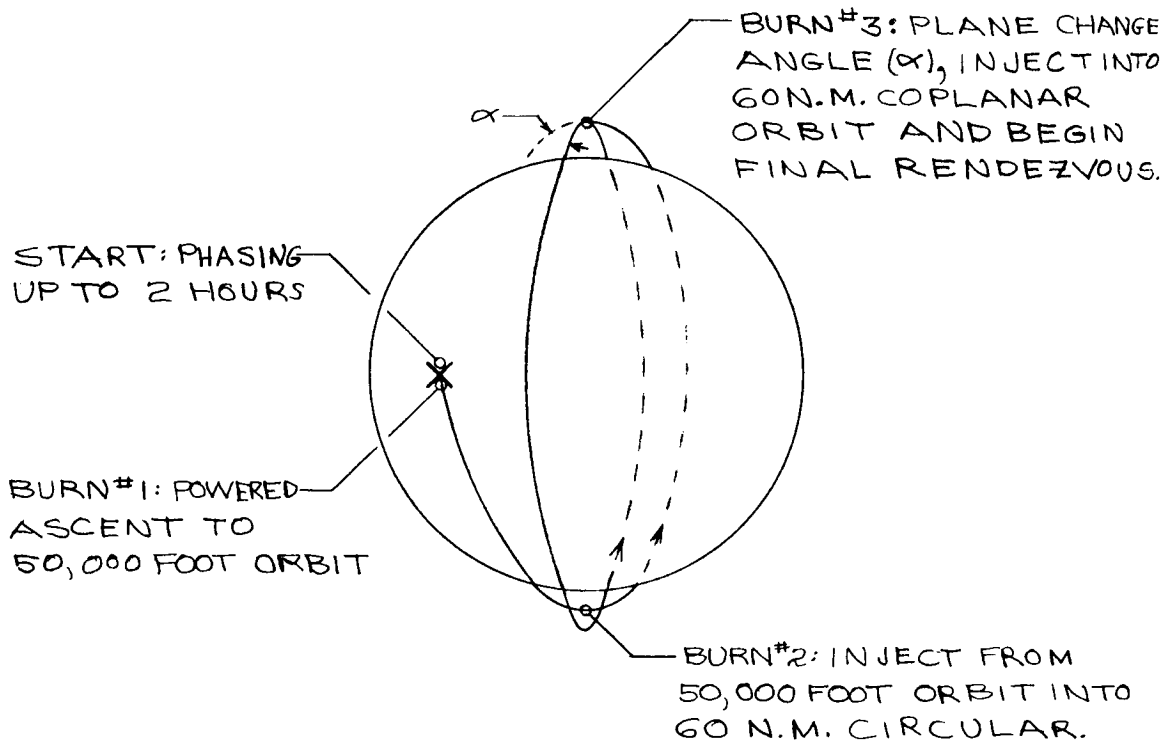

THREE-BURN ASCENT

TIME: 4.9 HOURS

ASCENT + COAST	.7
180 TRANSFER	1.0
RENDEZVOUS	1.2
PHASING (ON GROUND)	<u>2.0</u>
	4.9

Fig. A-28 Three-Burn Ascent

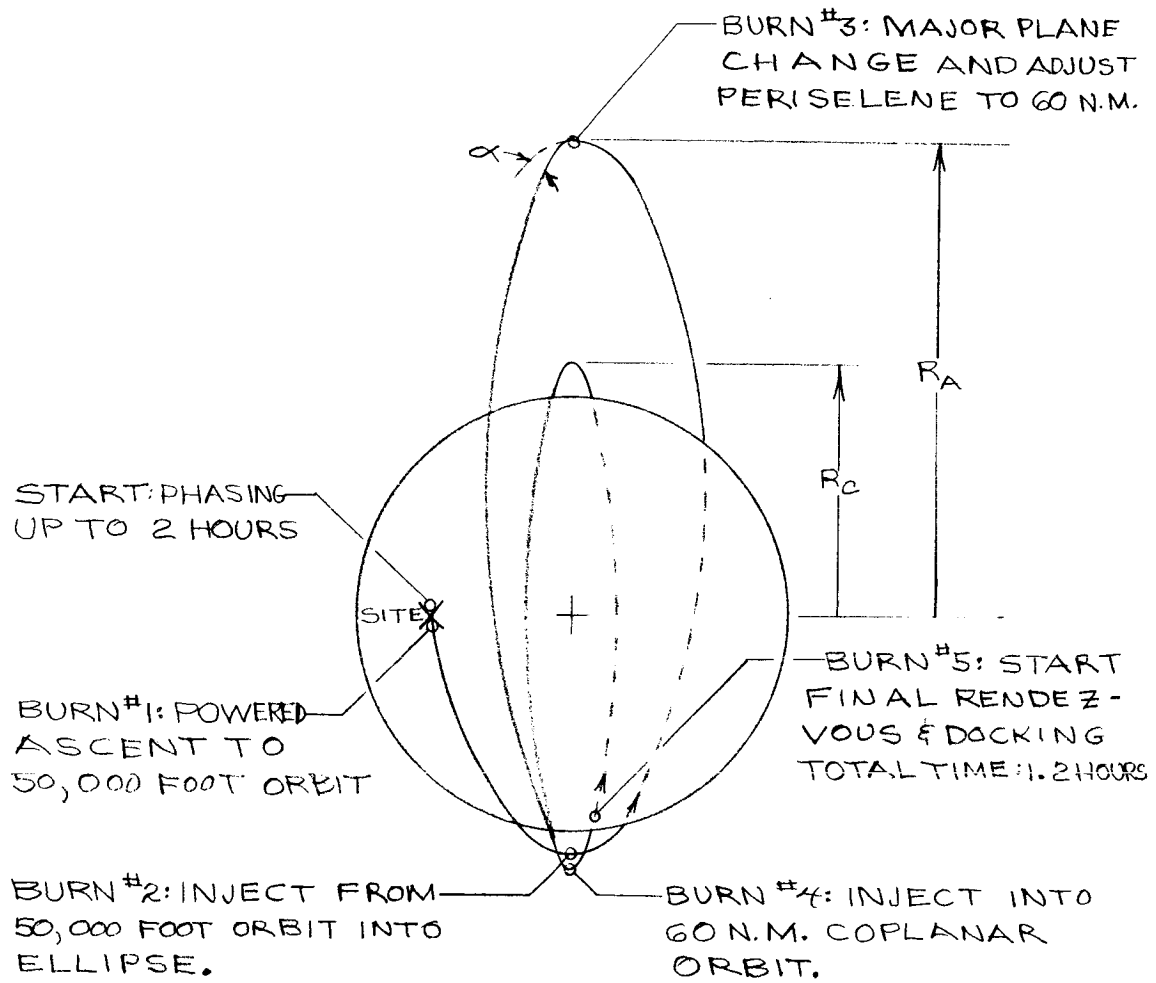

FIVE-BURN ASCENT

TIME: 5.9 HOURS FOR $R_A/R_C > 1.0$

Fig. A-29 Five-Burn Ascent

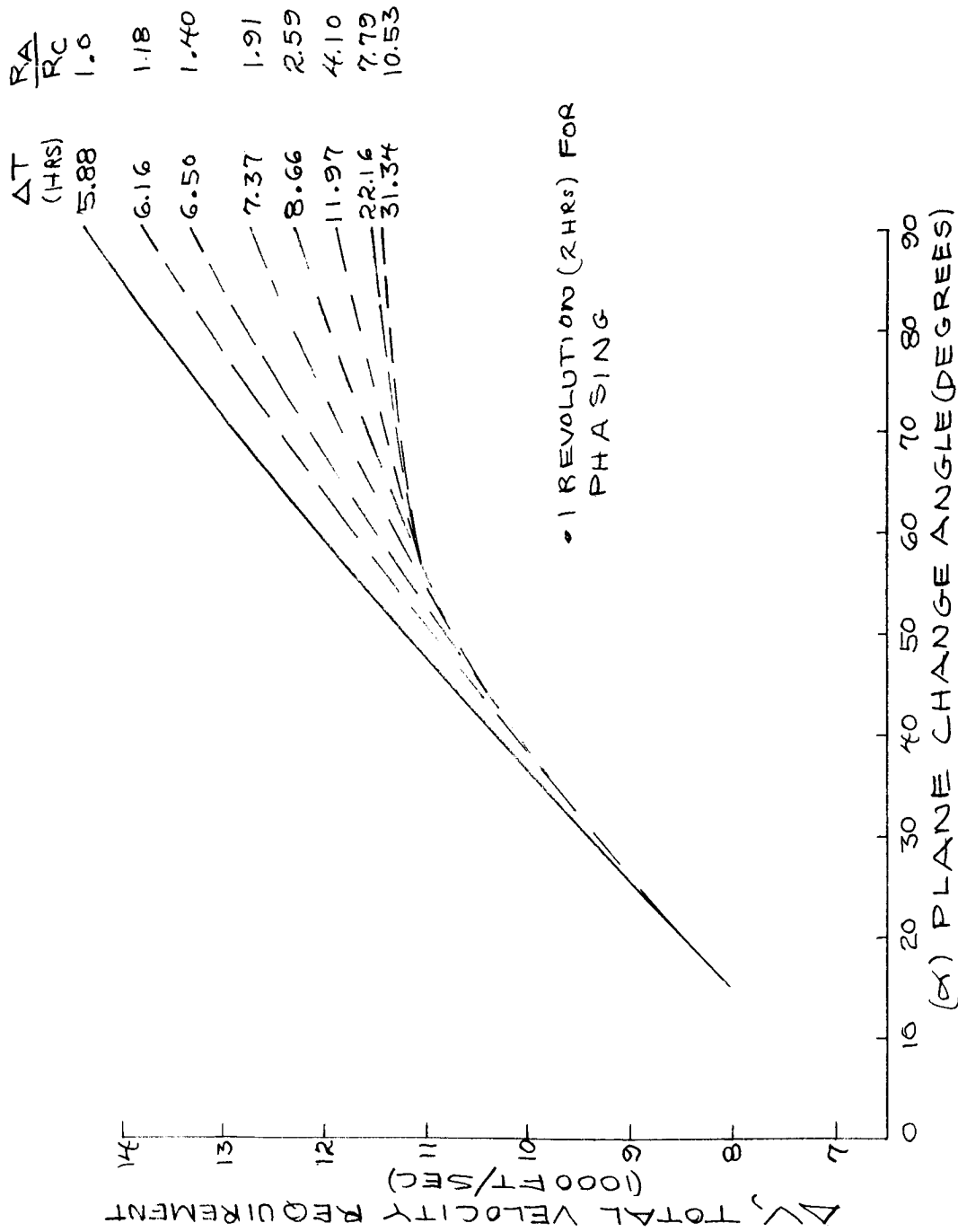

Fig. A-30 Five-Burn Ascent and Rendezvous ΔV vs α

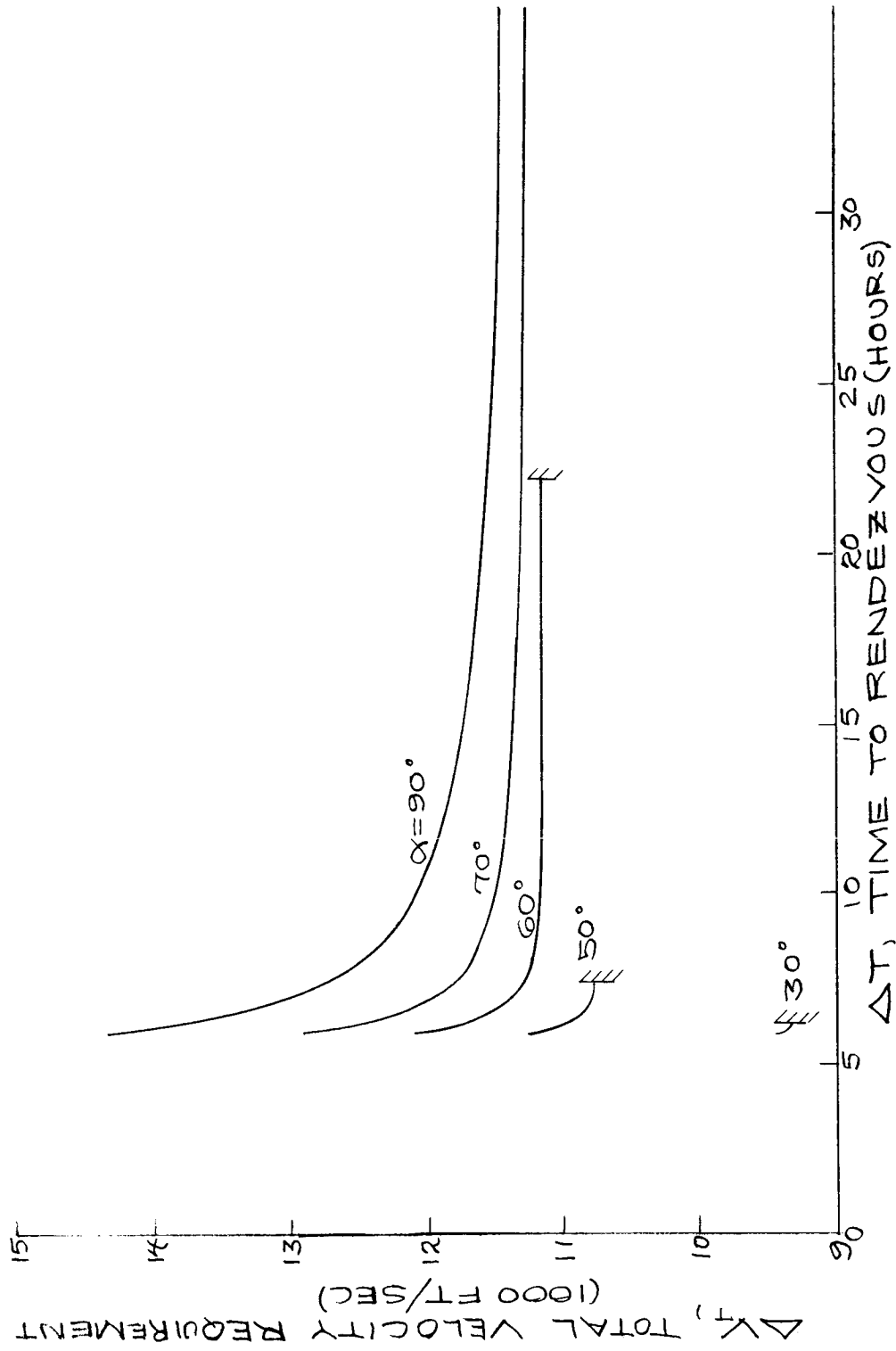

Fig. A-31 Five-Burn Ascent and Rendezvous ΔV vs Δ -Time

Orbit-to-Orbit Rendezvous

The plane change angle (α) required to make two orbits co-planar can be determined from the law of cosines from spherical trig:

$$\cos \alpha = \cos i_1 \cos i_2 + \sin i_1 \sin i_2 \cos a$$

as defined on Figure A-32

The simplest approach is the single burn at the line of nodes or intersection of the two orbit planes with ΔV required as:

$$\Delta V_{\alpha} = 2V \sin(\alpha/2)$$

where V is velocity at plane change.

Delta V can be saved using the previously described intermediate ellipse and optimizing the three burns to minimize ΔV . The results for the three burn case are given on Figure A-33 and cross-plotted on Figure A-34 as for the descent and ascent cases. The time shown for the solid line (one burn case) is the limit of the three burn case for $R_A/R_C \rightarrow 1.0$.

The time budget includes one-half period to arrive at plane change point (1 hour), labeled phasing on Figure A-33, 2 hours plus for ellipse, and 1.2 hours for final rendezvous as for the ascent case. Not included is the time required for phasing between the resulting two co-planar vehicles at the same altitude which may be as much as 180 degrees apart. The curves on Figure A-34 are terminated at the optimum ΔV as in the previous descent and ascent data.

Combined Plane and Altitude Change

Figure A-35 presents the ΔV required to simultaneously change plane and altitude. The two-burn method optimizes the normal 180 degree transfer for minimum ΔV while the "three burn optimal" utilizes the previously described transfer ellipse optimized for minimum ΔV for the required (α) and new circular orbit altitude.

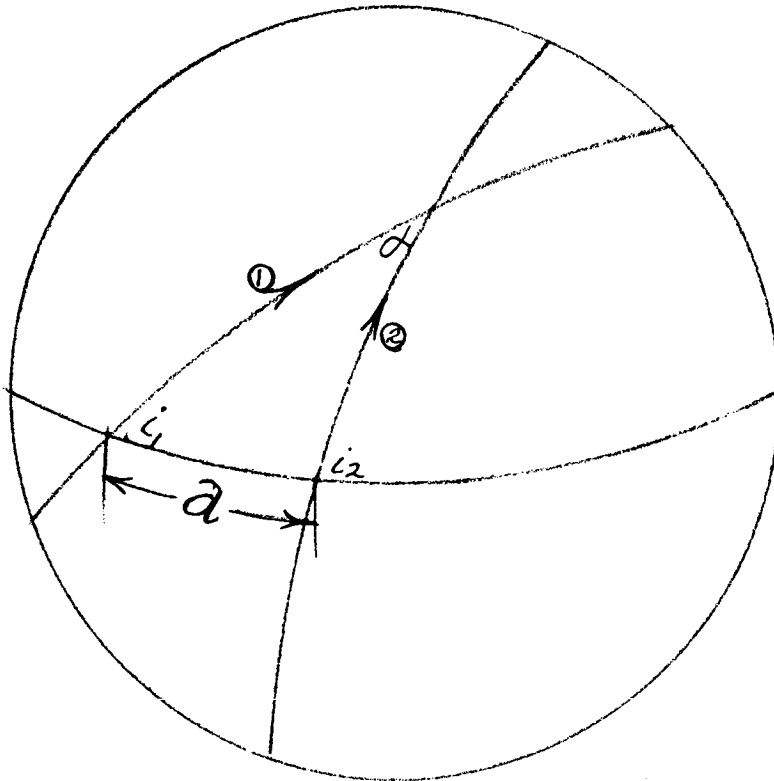

$$\cos \alpha = \cos i_1 \cos i_2 + \sin i_1 \sin i_2 \cos a$$

where a = the longitude difference
between the ascending
nodes of orbits 1 & 2

Fig. A-32 Orbit Plane Change Angle (α)

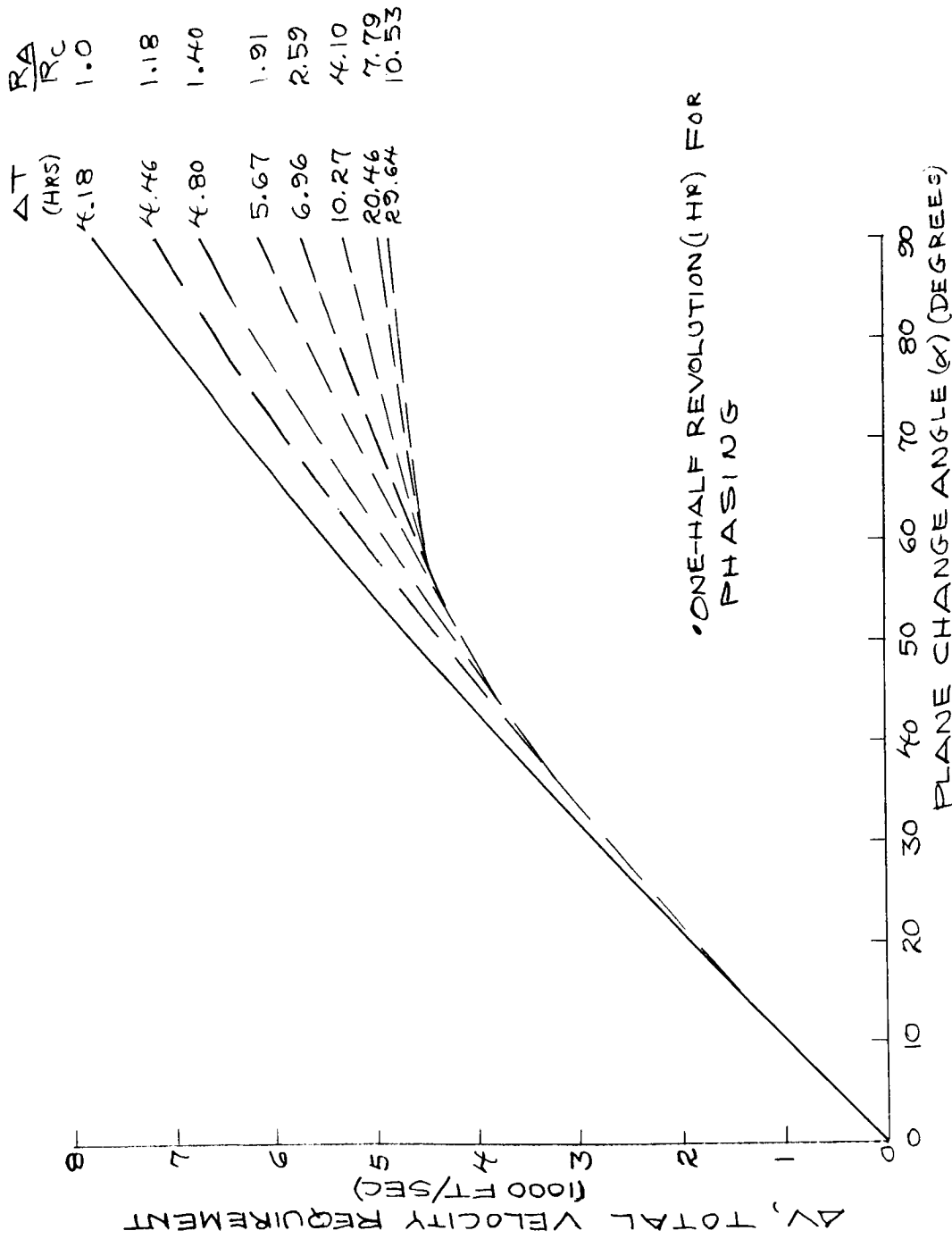

Fig. A-33 Orbit Plane Change (α) vs ΔV and Δ -Time Intermediate Ellipse

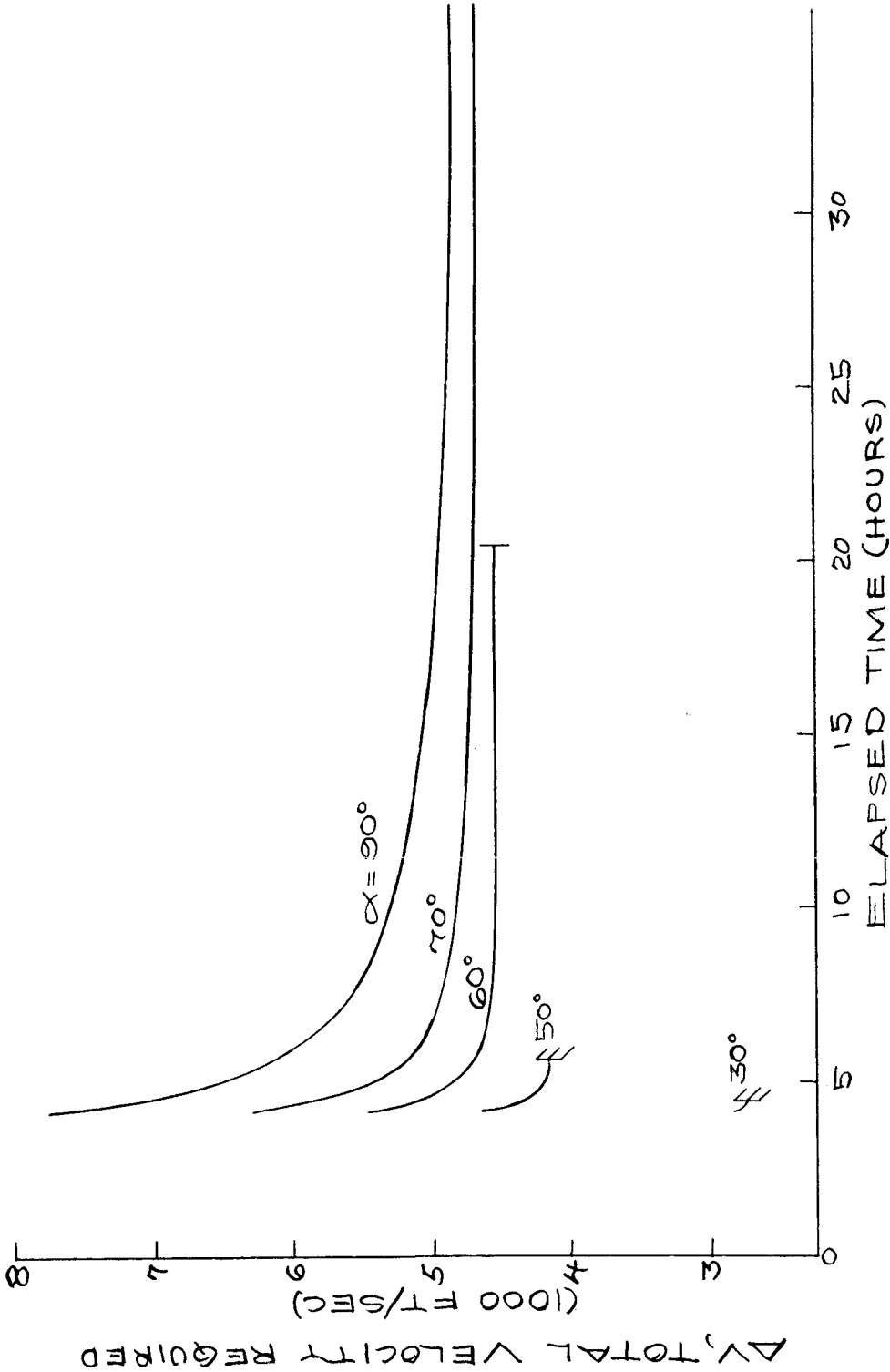

Fig. A-34 Orbit Plane Change Requirements ΔV vs ΔTime

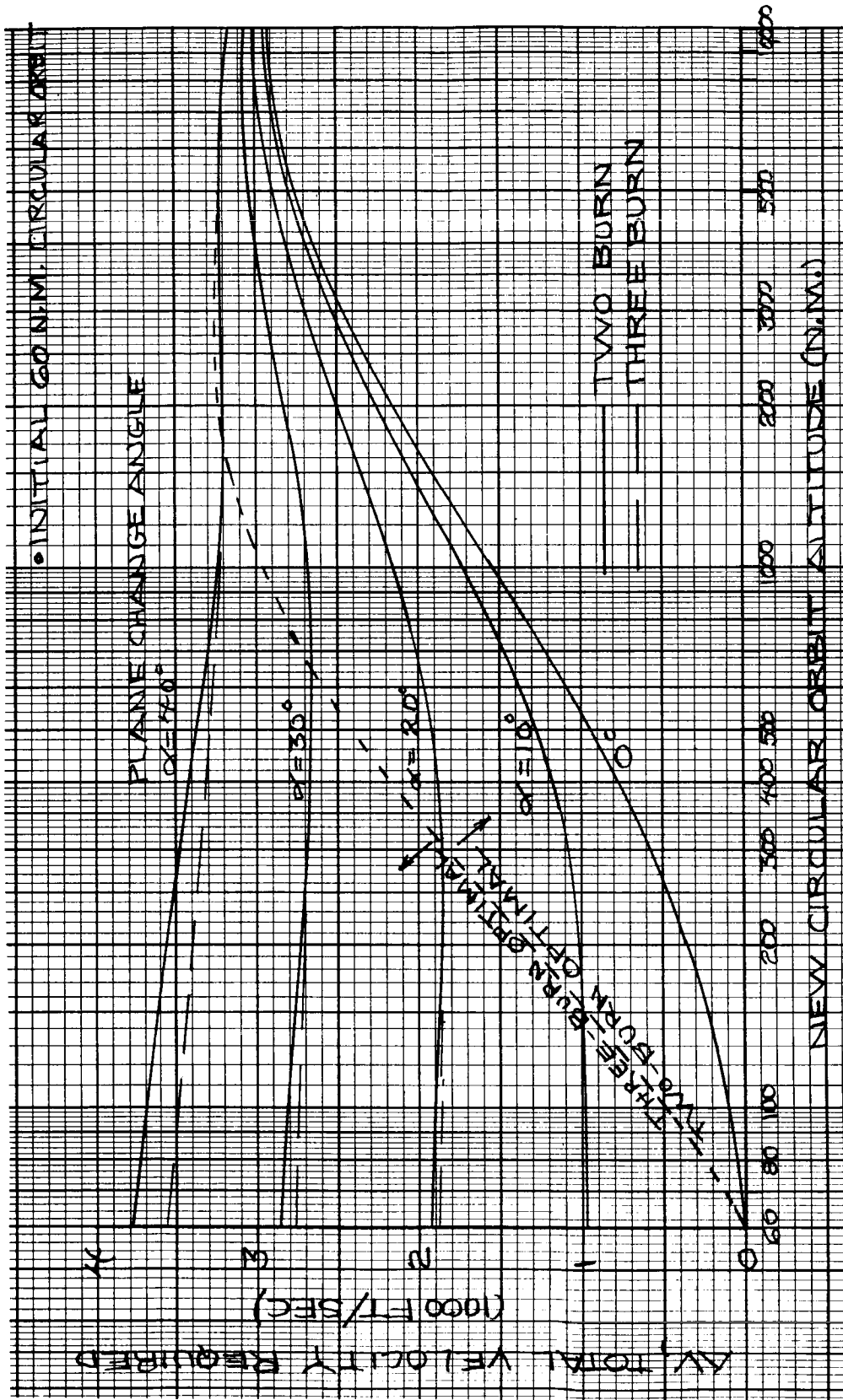

Fig. A-35 ΔV Required to Change Altitude and Plane

Rescue by Vehicle Based at L2 Libration Point

The previous sections have shown that rescue based in lunar orbit or even Earth orbit may require maximum plane changes of 90 degrees with the attendant large ΔV expenditures. One method of decreasing these ΔV requirements is to use intermediate transfer ellipses at the expense of response time. Another approach is to base the rescue vehicle at the libration point. Figure A-36 gives the ΔV required as a function of transfer time to arrive at a 60 n.m. lunar orbit. The libration point transfer offers the advantage of being able to enter any lunar orbit with a minimum ΔV for plane change. The total spread is approximately 400 ft/sec for orbits from 0 to 180 degrees. Phasing requirements (maximum 2 hours) may be met by adjusting the transfer time.

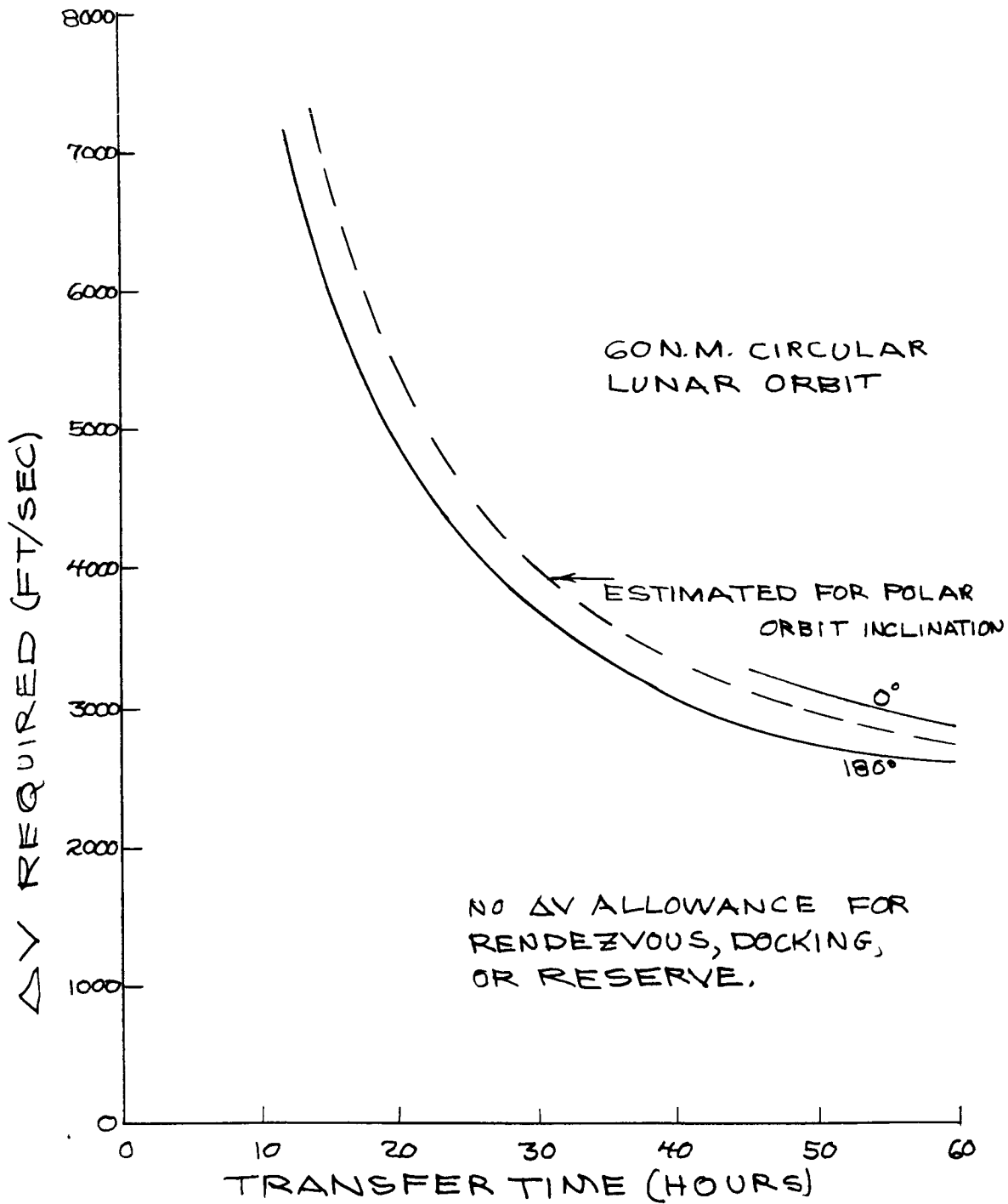

Fig. A-36 ΔV vs Δ -Time for One-way Transfer Between L_2 Libration Point and Lunar Orbit

Missed Lunar Orbit Insertion Rescue

The case of a trans-lunar vehicle failing to inject into lunar orbit at the approach hyperbola periselene was investigated for two trans-lunar flight times, 72 hours and 108 hours. The worst or maximum velocity case of zero burn at lunar orbit injection was postulated to determine maximum ΔV requirements for a rescue vehicle to overtake and rendezvous with the disabled vehicle from a 60 n.m. lunar orbit. The results are shown on Figure A-37, entitled "Rendezvous Velocity Requirements for Rescue," as a function of time to rendezvous.

The parameter is the delay or reaction time to launch the rescue vehicle. The case of zero delay is also included which represents the case of the nuclear shuttle where insertion burn is scheduled well before periselene is reached. Upon failure to burn, the lunar rescue vehicle could be notified and readied to rendezvous with zero delay from periselene. Rendezvous times longer than 12 hours do not provide much saving in ΔV . In addition, the longer the time taken to rendezvous, the longer the time required to return to lunar orbit as shown in the next two figures.

Using the span of rendezvous time given in Figure A-37, the velocity requirements were determined to return to lunar orbit as a function of return time for 108 hours and 72 hours trans-lunar flight times. The results are given on Figures A-38 and A-39, respectively.

The rescue from a missed lunar orbit insertion is feasible from a velocity requirement point of view with a total budget of 12,000 to 14,000 ft/sec.

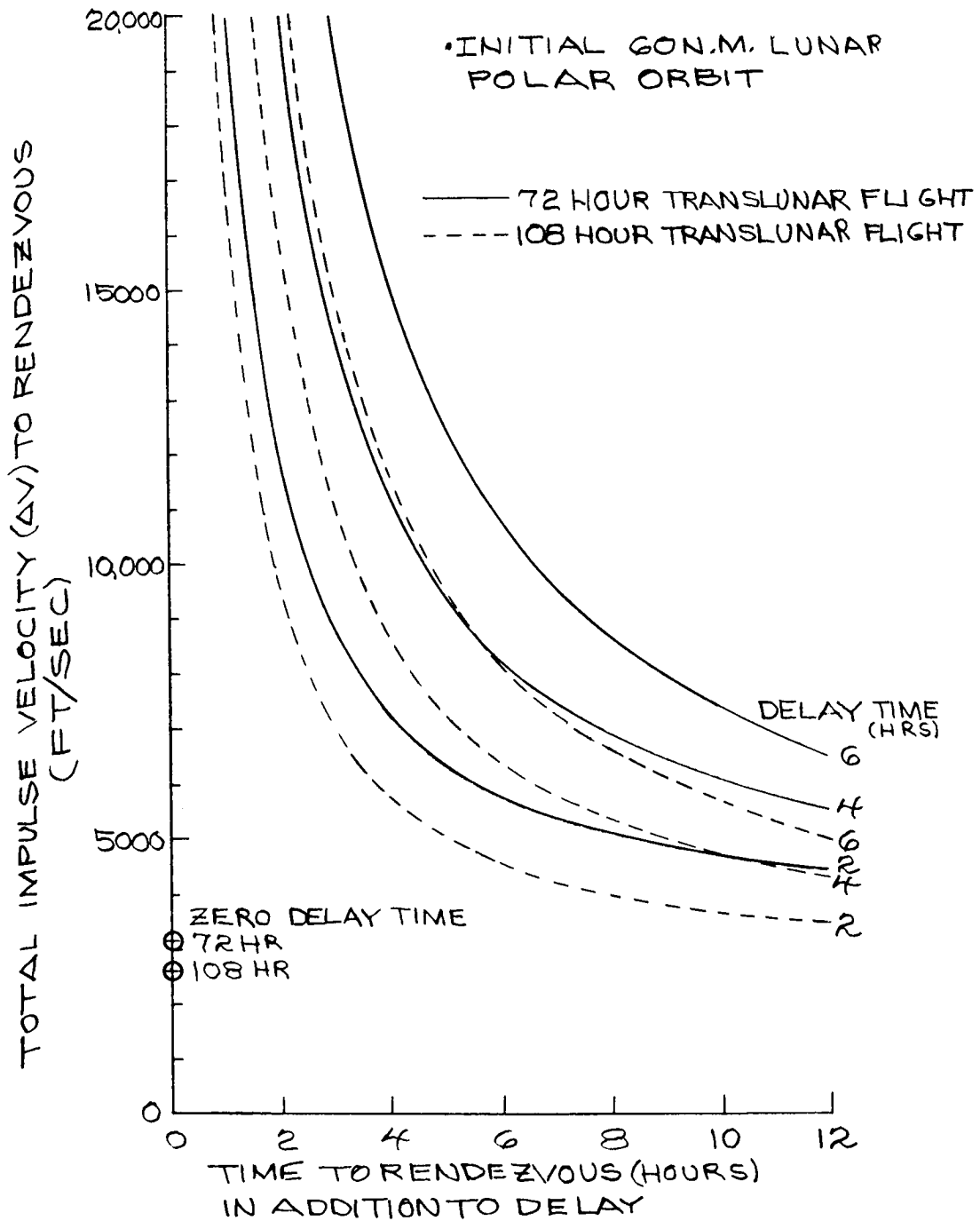

Fig. A-37 Rendezvous Velocity Requirements for Hyperbolic Rescue

VELOCITY REQUIREMENTS TO RETURN FROM RENDEZVOUS TO LUNAR ORBIT
FOR CONSTANT RENDEZVOUS TIMES MEASURED FROM APPROACH HYPERBOLA PERISELENE

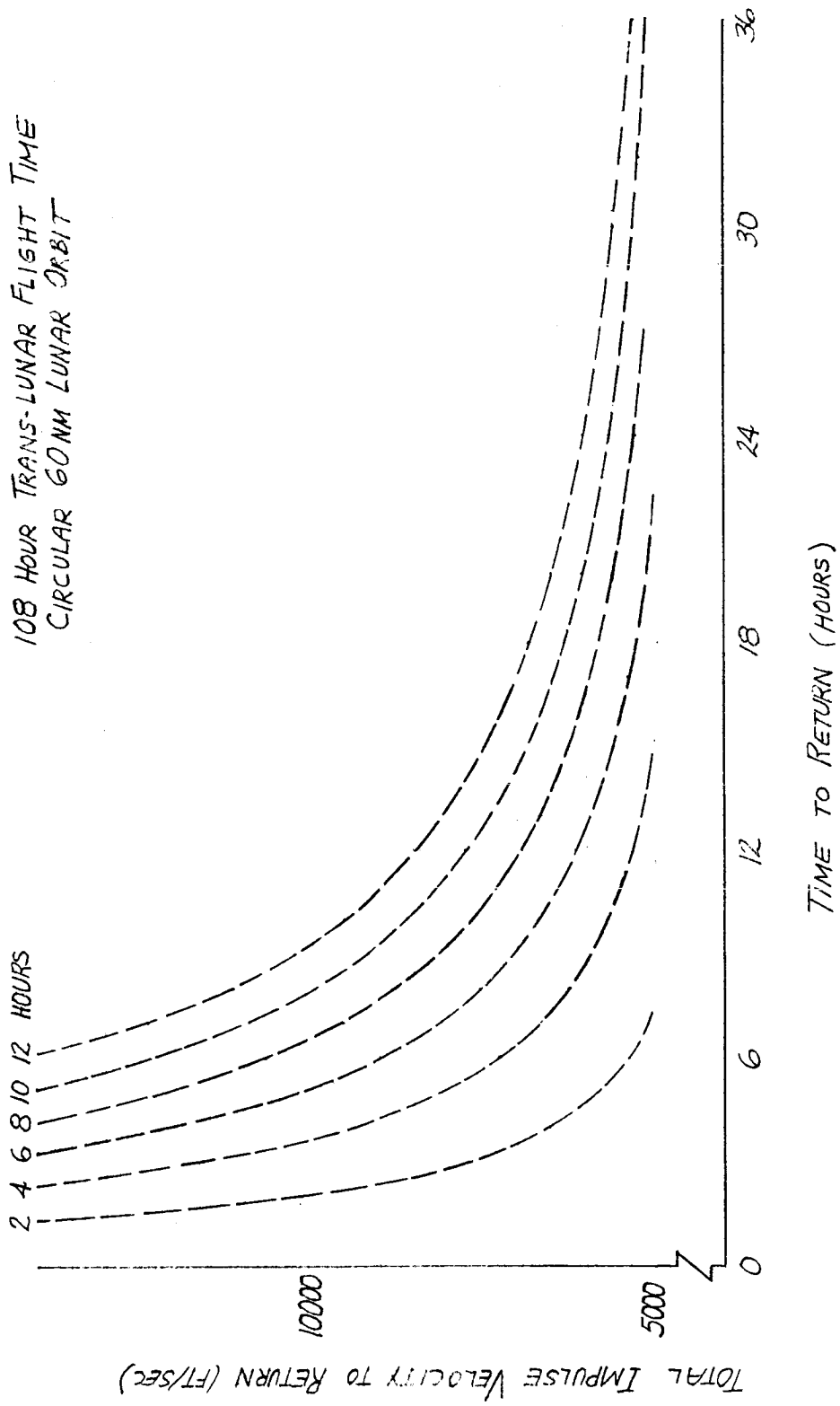

Fig. A-38 ΔV to Return from Rendezvous to Lunar Orbit - 108 hr Trans Lunar ΔT

VELOCITY REQUIREMENTS TO RETURN FROM RENDEZVOUS TO LUNAR ORBIT
FOR CONSTANT RENDEZVOUS TIMES MEASURED FROM APPROACH HYPERBOLA PERISELENE

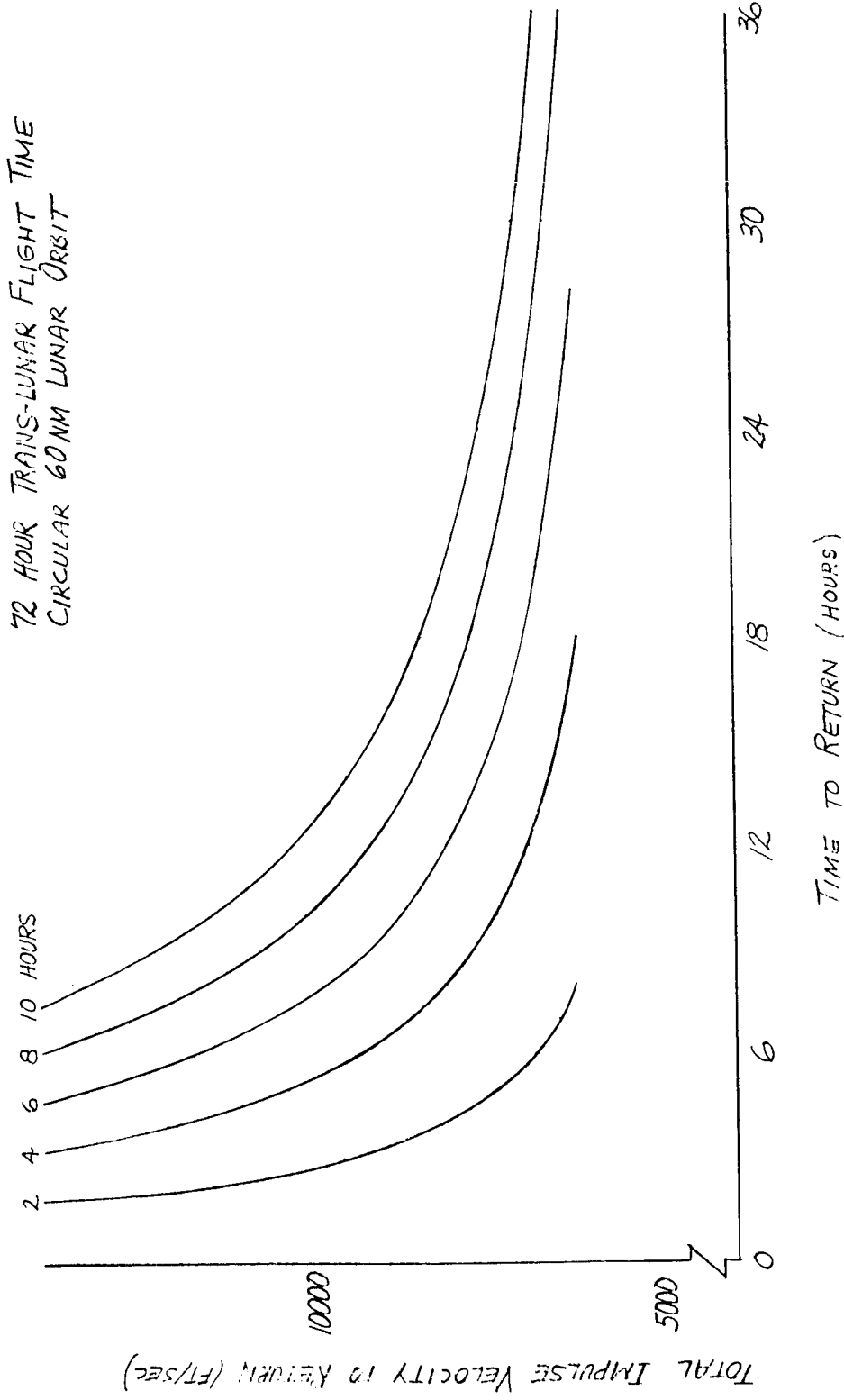

Fig. A-39 ΔV to Return from Rendezvous to Lunar Orbit - 72 hr Trans Lunar ΔT

Appendix B

LUNAR ESCAPE/RESCUE COMMUNICATIONS GUIDELINES

1.0 LUNAR EMERGENCY COMMUNICATION

This appendix presents the characteristics of various candidates for lunar communications. Particular emphasis is placed on communications between various surface elements. The advantages of various modes and frequencies are considered followed by detailed discussion of alternate systems to those already in use in the Apollo program.

1.1 Communication Modes

Five modes of lunar surface-to-surface communications beyond the line of sight can be considered:

1. Low-frequency surface wave
2. Transmission line
3. Line-of-sight relays
4. Satellite relays
5. Earth relay

No conclusion can be drawn which clearly favors one mode over all the others because the utility of a particular mode depends on the mission, particularly the range. In the event of an extensive lunar program all of these modes can be used. Comparisons among various modes were made on the basis of power required to supply transmission losses and antenna losses and/or weight. Some comparisons are shown in Tables B-1 and B-2.

A low-frequency surface-wave system could be optimum for a mission which requires a lunar rover to always operate within 25 n.m. of a lunar base.

Transmission lines might be optimum between the main base and a remote, fixed shelter five miles away.

Line-of-sight relays could be optimum between fixed sites separated by a maximum of 50 n.m.

Real time communication from the Earth to the far side of the Moon seems to have only one solution, i.e., satellite relays, either lunar orbit or libration point.

The Earth relay mode could be optimum for missions which require movements of hundreds of miles over the Moon's surface.

Table B-1
PERFORMANCE CHARACTERISTICS OF VARIOUS COMMUNICATION MODES

Communication Mode	Bandwidth Capability	Distance Capability	Power Requirements
Surface Wave	<u>Narrow</u> , voice bandwidth	Depends on surface electrical characteristics 50 to 125 n.m.	<u>Severe</u> , hundreds of watts
Transmission Lines	<u>Narrow</u> , voice bandwidth (light weight line)	20 km 2 to 7 lbs/km	<u>Low</u> , fraction of a watt
Line-of-sight relays	Wideband (video)	About 15 km between stations	<u>Modest</u> , few watts
Satellites - Lunar Orbit and Libration Point	Wideband (video)	Not limited	<u>Modest</u> , several watts
Earth Relay	Wideband (video)	Complete coverage of visible side of moon	<u>Modest</u> , several watts

Table B-2
RELATIVE MERITS OF VARIOUS COMMUNICATIONS MODES

Communication Mode	Advantages	Disadvantages	Utility
Surface Wave	Omni-directional beyond the horizon	Large, inefficient bandwidth-limited antennas, requires high power for long ranges	Short range, beyond horizon voice and homing beacon
Transmission Lines	Not line-of-sight limited	Large weight for long ranges, deployment difficult	Short range
Line-of-sight Relays	Wide bandwidth, modest power requirements	Large number of active relay stations for long ranges	Short range links of one or two stations
Lunar Orbit Satellite (VHF)	Omni antenna can be used. No surface tracking or pointing for communications	Slight power increase for omni antenna. Tracking required for navigation	Communications between surface elements & OLS. Navigation Beacon
Libration Point Satellite (S-band)	Wide bandwidth. Modest Power. Surface Antenna tracking not reqd.	Surface Antenna pointing required. Stationkeeping required.	Long range communications for far side and relay to Earth and near side
Earth Relay	Wide bandwidth, modest power, complete coverage of near side of Moon.	Not applicable to far side of Moon. Antenna pointing reqd.	Communications to near side of Moon and relay between elements

1.2 Frequency Considerations

Three frequencies or bands may be considered for emergency communications:

- Low Frequency (LF) (50 KHz)
- Very High Frequency (VHF) (300 MHz)
- S-Band (2 GHz)

Propagation loss is proportional to the square of the frequency and the distance. Consequently, VHF requires less power than S-Band using isotropic antennas which require no pointing or tracking.

S-Band can operate on low power by taking advantage of large directional antennas. These large antennas concentrate the radiated energy into a narrow beam rather than radiating in a spherical manner. The larger the antenna, the smaller the beam, consequently higher gain or lower transmitter power.

The penalty in using narrow beams is the pointing accuracy required. At large distances such as Earth/Moon this is no problem. The following table gives the beam widths and diameters to cover the target object.

<u>Location</u>	<u>Target</u>	<u>Beam Width (θ)</u>	<u>2-GHz Antenna Diameter (ft)</u>
Earth	Moon	.52°	67.2
Moon	Earth	1.91°	18.3
Libration Point (L ₂)	Earth	1.6°	21.8
Libration Point (L ₂)	Moon	3.1°	11.3
Libration Point (L ₂)	Moon/Earth	4.7°	7.5

As long as the beamwidth covers the target object in its field, pointing is not required except for movement of the antenna such as Earth rotation where the antenna must be steered to keep the target within its beam. For all other combinations above, the motion of the locations is so slow that point-

ing presents no problem. For lunar satellites the beam width can be made large enough to cover the area in view from the satellite. Thus the requirement for steering the satellite antenna is avoided. However, at low altitudes (4000 Km or less) the beamwidth to cover the surface in view is too wide for S-band antennas. Consequently, S-band for Lunar Satellite to surface is less attractive than VHF. For moving antennas such as on a rover vehicle directional antennas are not practical unless the vehicle is stopped. For S-Band the CSM or LM use 3 to 5 degree beams and an antenna tracking and steering system to maintain contact with the Earth and in practice this has worked very well. However, for a moving lunar surface vehicle the absence of an active attitude control system to maintain a stable platform would require much higher response times and attendant energy requirements.

The Apollo program has demonstrated the capability of S-band for lunar distances and VHF for line-of-sight between lunar orbit and surface (CSM/LM). In addition, future lunar programs will incorporate as much or more capability than already exists for Apollo for a communications between Earth and the program elements, i.e., Orbiting Lunar Station (OLS), Prime Transport Vehicle (PTV), Lunar Surface Base (LSB), and Space Tugs. For lunar nearside operations contact can be made directly with the Earth and the use of the Earth as a relay point will allow communication between any of these elements. For lunar farside operations, additional means will be provided for continuous contact with Earth and each other. Two options are available as relay point, the libration point, and a satellite relay. For a libration point relay, the characteristics are similar to Earth/Moon, and S-band is the likely candidate.

Assuming that normal communications will consist of S-band and VHF as outlined above, this appendix is devoted to the characteristics of other candidate systems for emergency communications between lunar surface elements. The systems are low frequency, surface relay, and lunar satellite.

1.3 Bandwidth Considerations

Emergency communications in contrast to normal scientific requirements require only narrow bandwidths. Voice or even code (telegraphy) is entirely adequate. The use of narrow band has an attendant decrease in power requirements. Required transmitter power in decibels (dbw) referenced to one watt is directly proportional to the bandwidth in cycles per second (Hertz). Voice requires approximately 3000 (Hertz) while code is nominally 10 (Hertz).

The use of narrow bandwidths allows consideration of possibilities other than S-Band relays. These are low frequency, line-of-sight relays including satellites, and hardline or wire transmissions.

VHF walkie-talkie type of equipment with power of less than a watt is adequate, but only for line of sight. Estimates based on lunar topography place the range at 20 Kilometers at best. A variation of VHF line of sight is the use of relay stations placed every 15 to 20 Kilometers along the exploration path. This has the obvious rigidity of a hardline system coupled with the difficulty of emplacement.

2.0 LUNAR SURFACE EMERGENCY COMMUNICATIONS

The characteristics of various systems considered for emergency communications have been summarized on on Figure B-1 in terms of power versus range. These are power requirements for a 3 (KHz) voice channel. In addition, the power requirements for LF telegraphy are given.

2.1 S-Band Relays

The use of Earth-relay and libration point relay for near and far-side exploration, respectively, is most attractive from a transmitter power required viewpoint. A four to six foot dish antenna is not excessive. However, communications while the rover vehicle is moving is not possible because of the pointing accuracies required unless a sophisticated antenna system similar to the CSM is used. Consequently, the base cannot contact the rover or vice versa unless it has stopped and the antenna has been aligned.

2.2 Surface Relays

VHF provides the simplest and lightest installation for continuous communications with astronauts out on a sortie. However, for long traverses, the burden is shifted to the installation of relay stations. The curve on Figure 2-1 is taken from the results of reference (2). A concept for microwave relays (1 GHz) is given in a later section. This concept includes wide-band capacity for scientific data transmission in addition to emergency communications power requirements, for either VHF or microwave are comparable. VHF or microwave relays have comparable power and weight requirements being in the order of 10 watts input and 10 pounds of weight. A description of a 15 watt Radioisotope Thermoelectric Generator (RTG) for powering the relay stations is also given. This unit provides 15 watts and weighs 25 pounds.

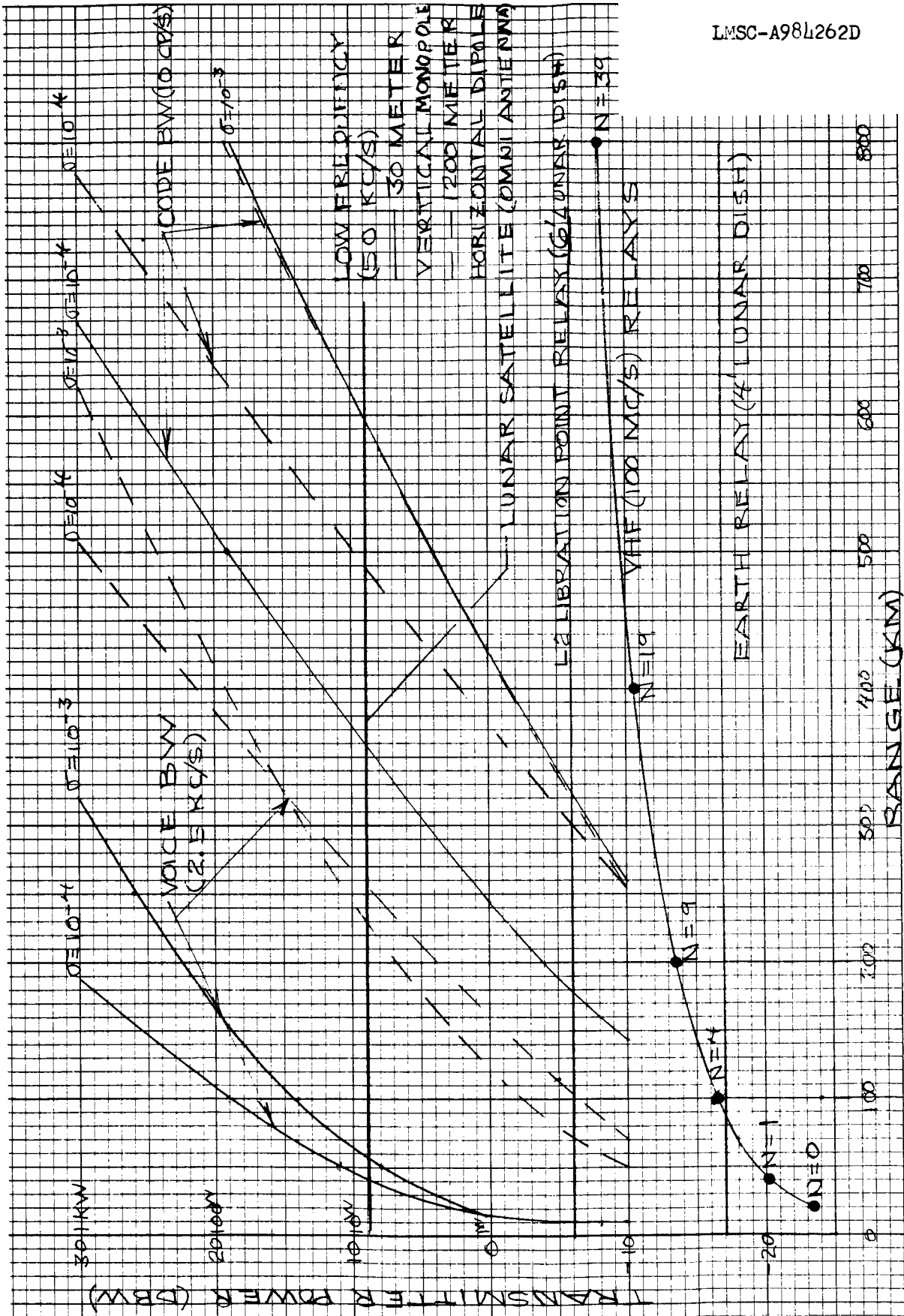

Fig.B-1 Lunar Surface System Voice and Code Transmitter Power Vs Range

2.3 Hardline System

Not shown is the use of wire phone line from the rover to the base. Continuous contact could be provided by slip-rings on the rover. Reference (2) gives estimates from 1.8 to 3.5 pounds per Kilometer including insulation and loading coils for aluminum and 3.2 to 7 pounds/Km for copper wire.

2.4 Low Frequency

The use of low frequency for lunar surface communications has been the subject of much theoretical study. The missing information has been the conductivity of the lunar surface. It is estimated that the value lies between 10^{-3} and 10^{-4} mhos/meter. Early Apollo information confirms this range. References (1) and (2) both postulate Low Frequency Systems. Low Frequency systems have two distinct characteristics, large transmitter power and long antennas. In their favor is simplicity of operation, equipment, and antenna.

2.4.1 Transmitter Power

The transmitter power has been limited to 1 Kilowatt for our considerations. Reference (2) postulates a 1 Kw transmitter design weighing 34 pounds and having an efficiency of 85 to 90%. Figure B-2 presents transmitter power versus weight from references (1) and (2). Reference (1) postulates the use of two transmitters at the lunar base and the use of a ferrite loop antenna on the rover to provide direction finding (DF) capability using code signals from two horizontal dipoles at right angles similar to the old aircraft beam of "a" and "n."

2.4.2 Antennas

The major problem of low frequency is the transmitting antenna on the rover vehicle. Two concepts are presented on Figure B-1; the use of a $.2 \lambda$ (.2 of the wavelength) horizontal dipole (at 50 KHz $.2 \lambda = 1200$ meters) laid on the lunar surface, and a 30 meter vertical monopole. The horizontal dipole gives

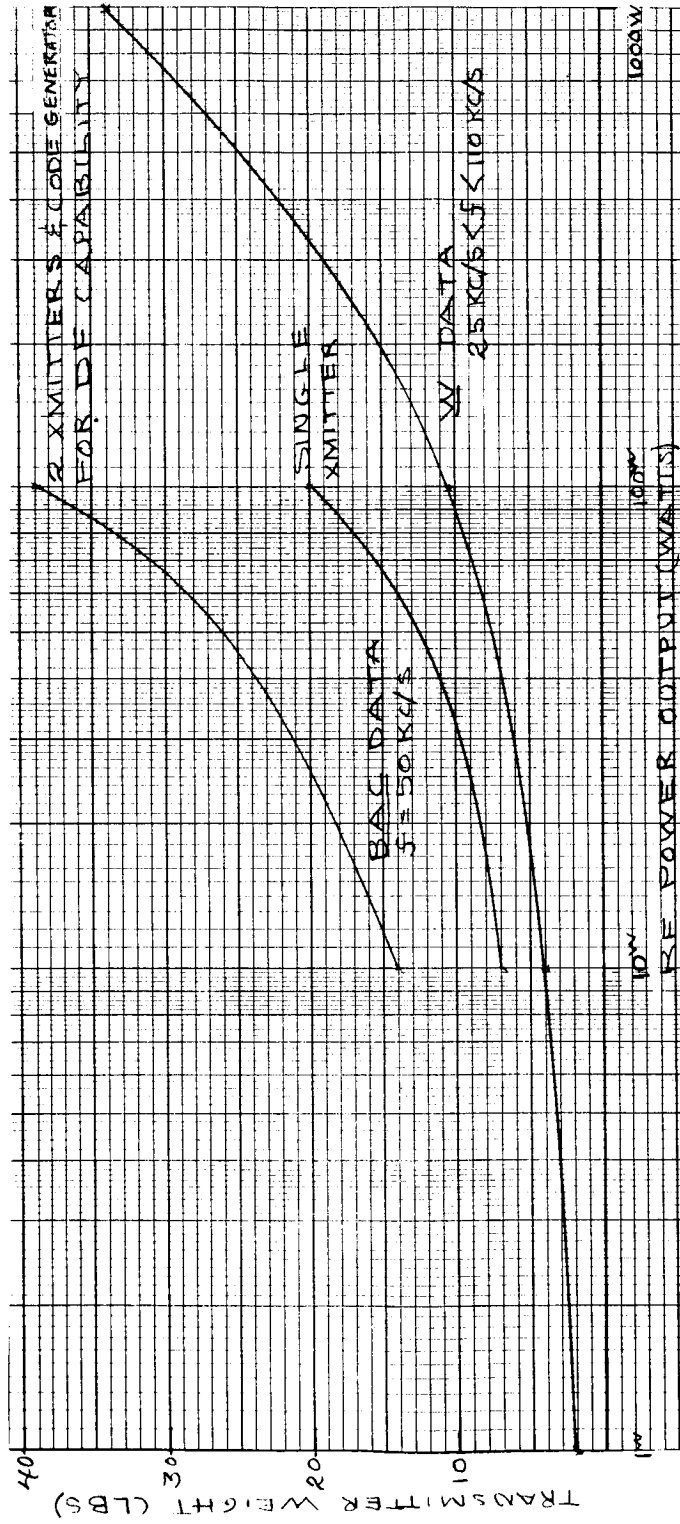

Fig. B-2 Low Frequency Transmitter Weight Vs RF Power Output

better range because it is longer than the vertical monopole. The two antennas are compared on Figures B-3. The horizontal dipole system (Reference (1)) has two horizontal dipoles at the base weighing 67 pounds with a single dipole at the rover which must be deployed for transmitting. For receiving and direction finding at the rover, a ferrite loop (74 pounds) is used. The vertical monopole system offers the capability of continuous transmitting and receiving but requires more power. On Figure B-1 the solid lines are the 30 meter vertical monopole (10 pounds) and the dashed lines for the 1200 meter horizontal dipole at a frequency of 50 KHz.

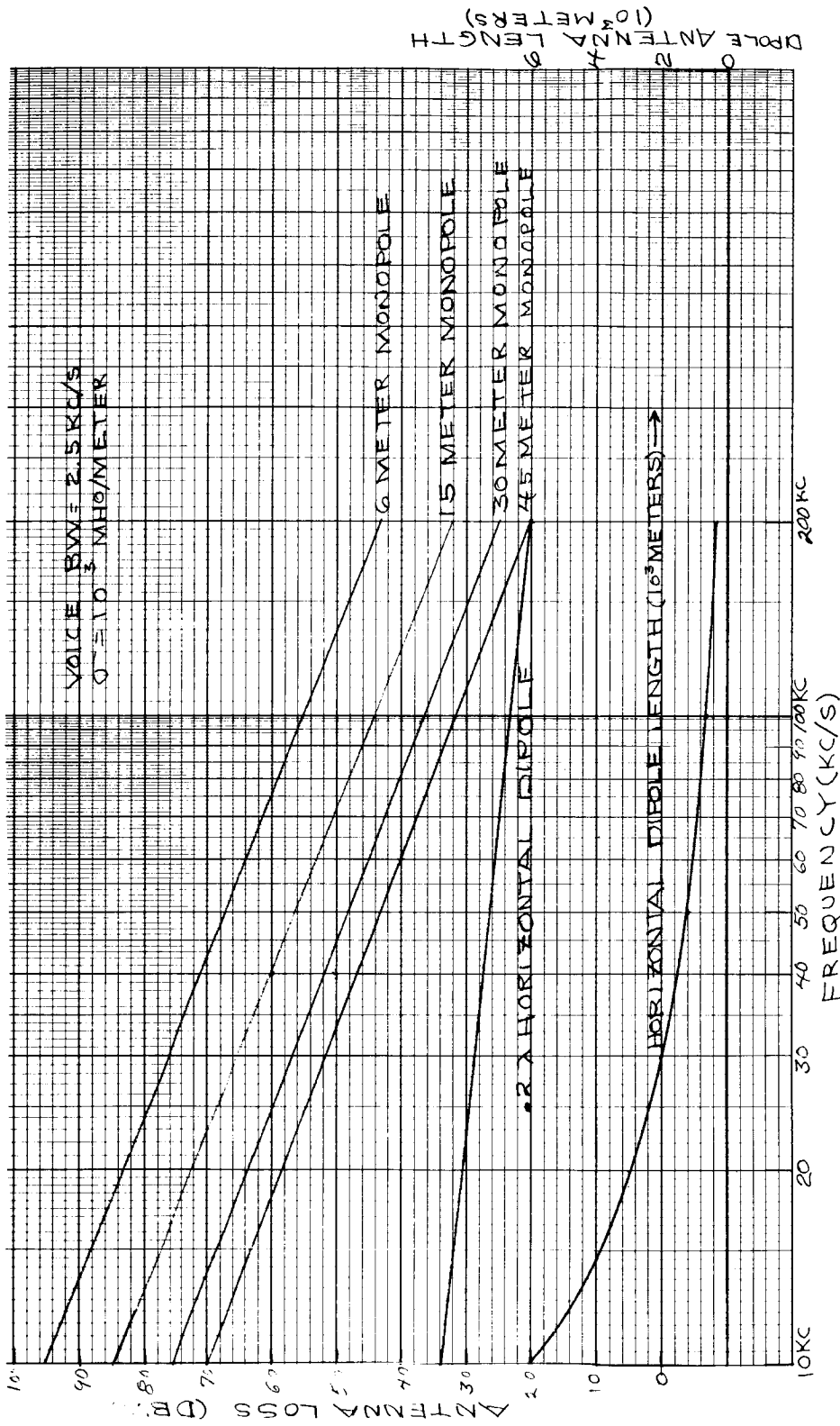

Fig. B-3 Antenna Loss of Vertical Monopole and Horizontal Dipole Vs Frequency

3.0 LUNAR SATELLITE RELAY

The various factors involved in lunar satellite to surface communications are presented. In the following discussion, the use of satellites at varying altitudes from 100 to 7000 kilometers are considered including the Orbiting Lunar Station (OLS) in a 60 n.m. (111 Km) polar orbit. Bandwidth considerations are limited to voice and telegraph for emergency situations. Extensive treatment is given on satellite coverage for both single and multiple satellites in an orbit and for multiple orbits.

3.1 Lunar Satellite Geometry

The geometric relations for a lunar satellite to lunar surface link are shown on Figure B-4. The forcing variable is satellite antenna beamwidth (θ). The beamwidth should be as narrow as possible to conserve transmitter power. On the other hand, the beam width must be wide enough to cover the lunar surface in view, in order to eliminate the need for tracking of surface points by the satellite antenna. Beamwidth is a function of altitude (h) and lunar radius (r) according to the equation:

$$\theta = 2 \sin^{-1} \left(\frac{r}{r+h} \right)$$

where $r = 1738$ (km)

Contact Angle (CA) is the swath width of the satellite antenna in surface degrees according to the expression:

$$CA = 180^\circ - \theta \quad \text{or} \quad CA = \cos^{-1} \left(\frac{r}{r+h} \right)$$

The slant range (SR) is the maximum distance from the satellite to the edge of swath width and is expressed as

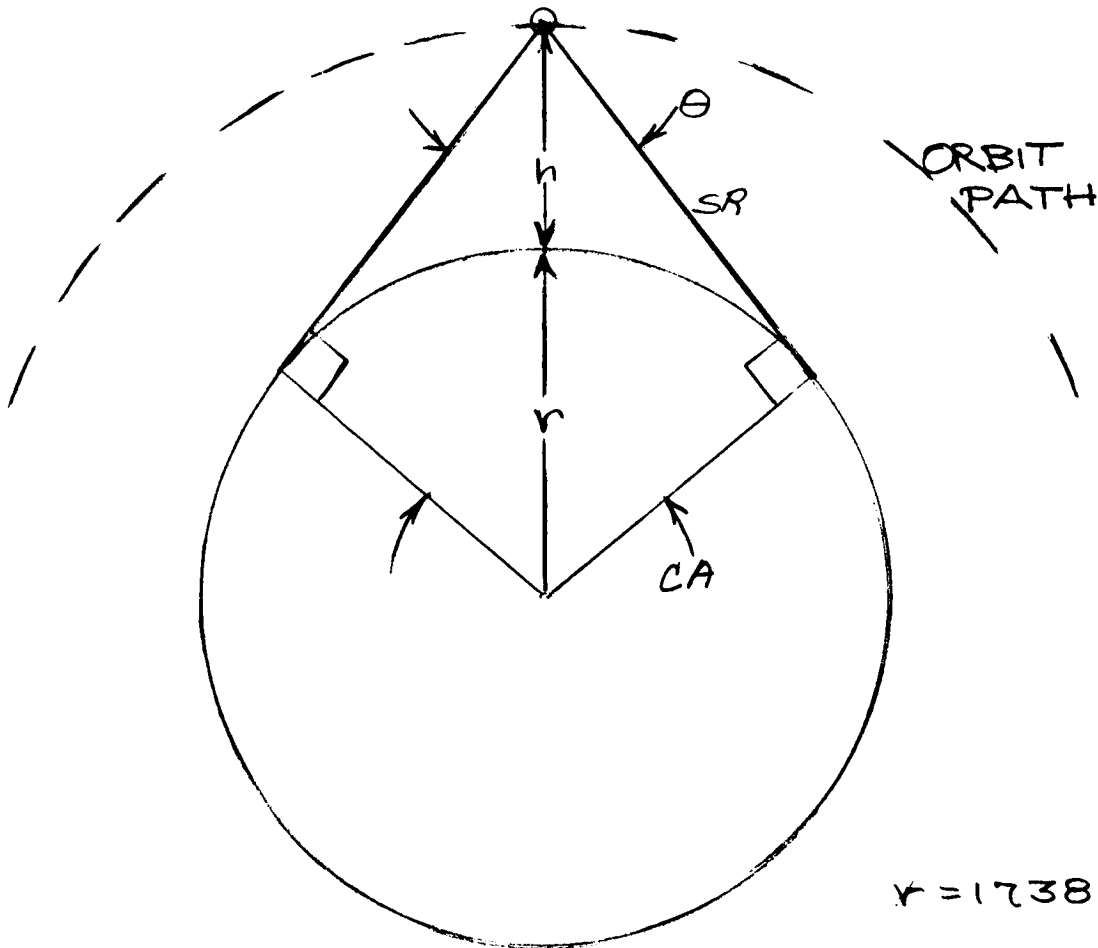

$$r = 1738 \text{ KM}$$

$$\frac{\theta}{2} = \sin^{-1}\left(\frac{r}{r+h}\right)$$

$$\frac{CA}{2} = \cos^{-1}\left(\frac{r}{r+h}\right)$$

$$SR = \sqrt{h(2r+h)}$$

Fig. B-4 Lunar Satellite Geometry

$$SR = \sqrt{h (2 r + h)}$$

h = altitude (km)

r = lunar radius = 1738 (km)

Beamwidth (θ), Contact Angle (CA), and Slant Range (SR) are shown on Figure B-5 as a function of satellite altitude (h).

Lunar Satellite Coverage Time (CT), the time that a point directly under the satellite orbit is in view can be determined from the Contact Angle (CA) and the orbit period (τ):

$$CT = \frac{CA}{360} \tau$$

where τ is the period and CA is the Contact Angle in surface degrees

is given by the expression:

$$\tau \text{ (sec)} = 2\pi \frac{(r + h)^{3/2}}{\mu_m^{1/2}}$$

where r = radius of Moon = 1738 Km

h = altitude in km

μ = gravitational parameter for Moon

$\mu_m = 4.903 \times 10^3 \text{ Km}^3/\text{sec}^2$

The coverage geometry for a point directly under a single satellite is shown on Figure B-6. For a point in the center of the swath width the contact length is equal to the Contact Angle (CA).

The orbital period (τ), Contact Time (CT), and No Contact Time (NCT) are shown on Figure B-7 in hours and percent as a function of altitude. Because of the rotation of the lunar surface under the satellite track, these times are only exact for an equatorial surface point and orbit or a polar surface

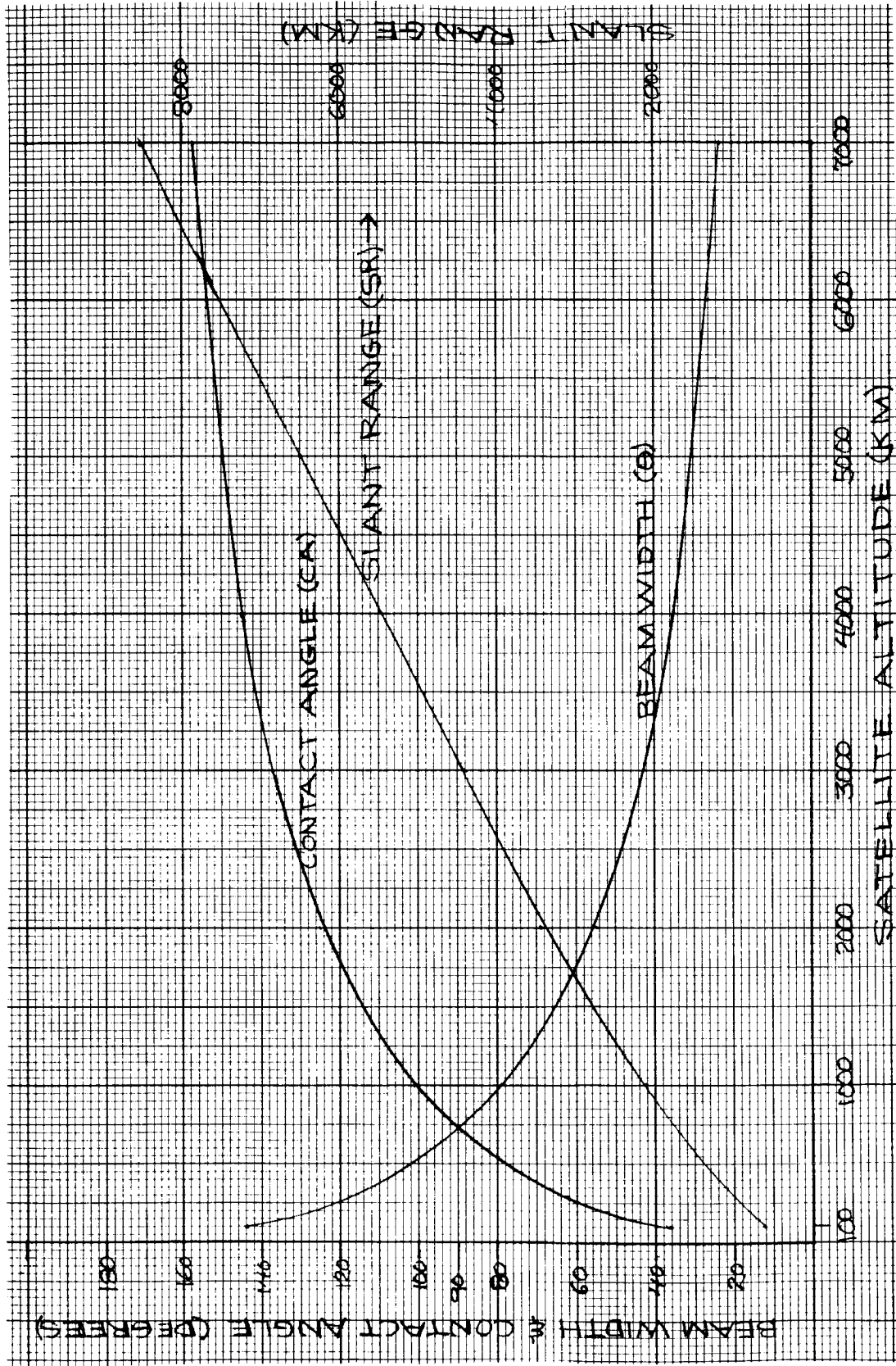

Fig. B-5 Lunar Satellite Coverage

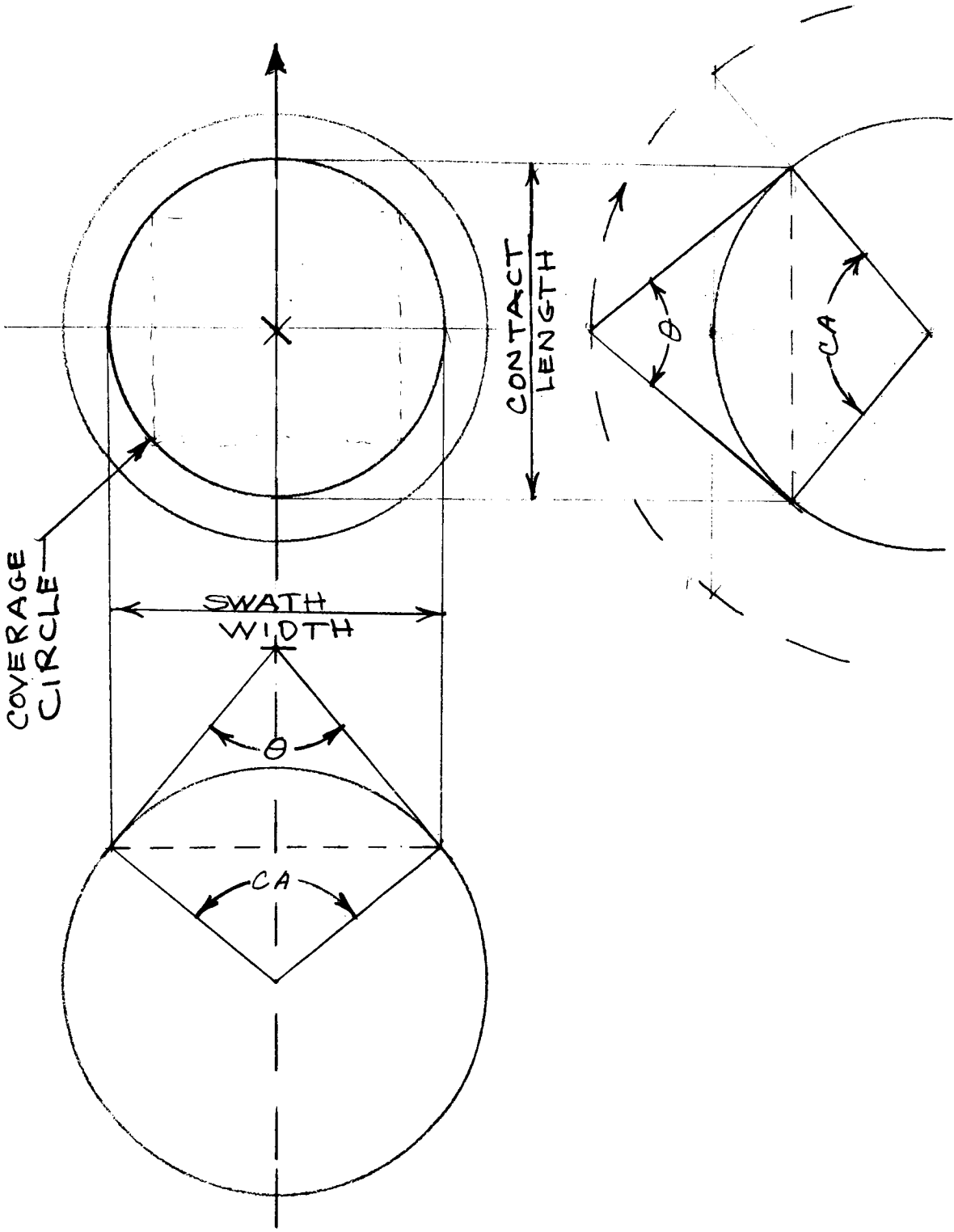

Fig. B-6 Coverage Geometry

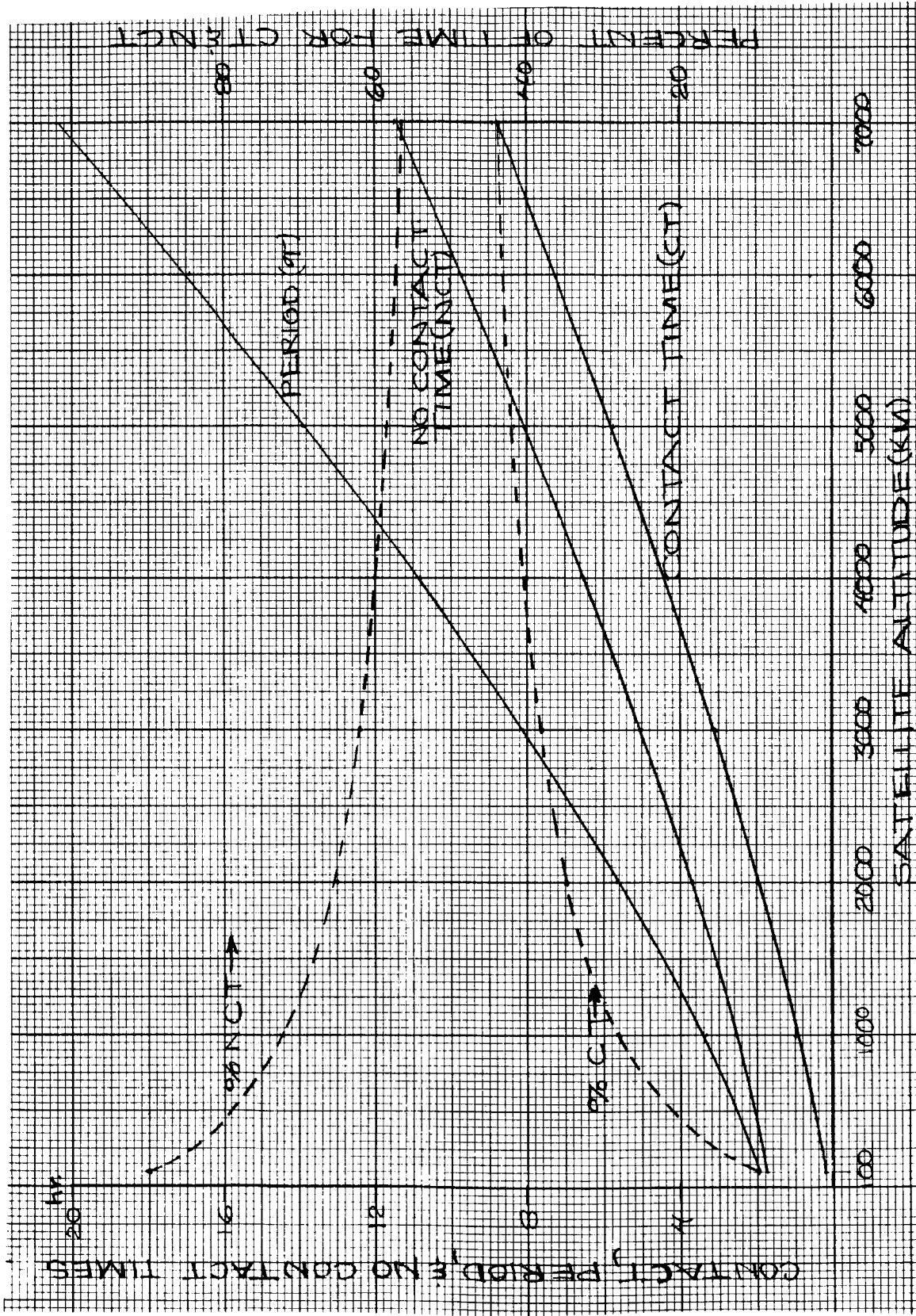

Fig. B-7 Lunar Satellite Coverage Time Along Track

point and orbit. The maximum time for an equatorial surface point to pass across a polar satellite's swath is shown on Figure B-8.

As given by the expression:

$$CT = \frac{CA}{360} \tau$$

where $\tau = 28$ days, the period of the Moon's rotation.

Because the satellite is viewed on both its ascending and descending path the maximum time a point is not directly under the satellite track is 14 days.

The preceding curves are theoretical limits for points directly under the local vertical. Allowance for a finite contact time at edges of the swath width must be considered.

The effect of this consideration is to change the shape and reduce the area of effective coverage as shown in Figure B-9 by the solid lines. The contact length and swath width are defined as the central angles α and φ , respectively, in terms of surface degrees. The swath width (φ) and contact length (α) are related to each other as a function of altitude according to the expression:

$$\cos \varphi + \cos \alpha = 2 \left(\frac{r}{r+h} \right)^2$$

where r = radius of moon

h = altitude.

In that beam width (θ) to cover the visible surface and the resulting contact angle (CA) are also functions of altitude and radius, the following relations obtain:

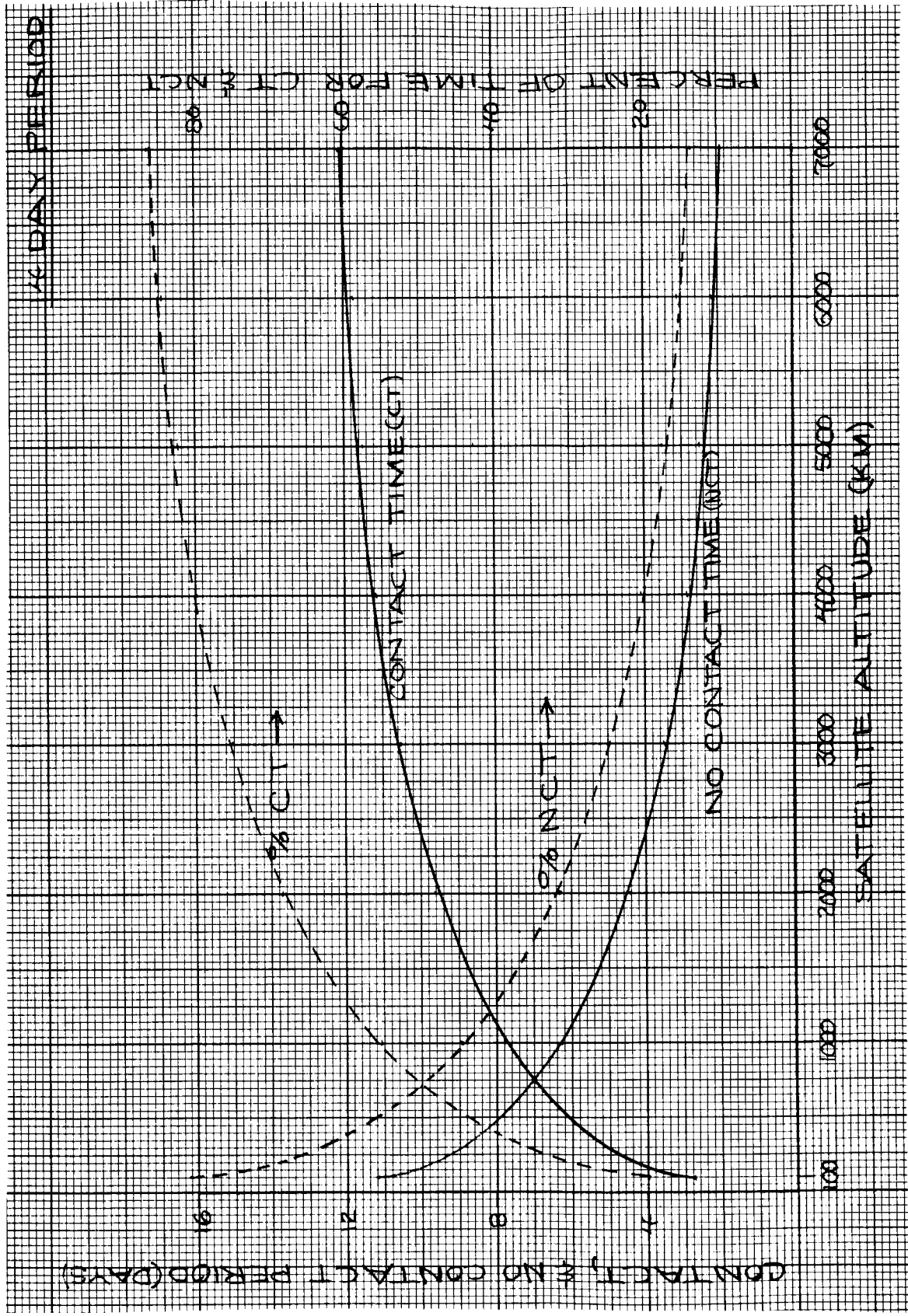

Fig. B-8 Lunar Satellite Coverage-Cross Track

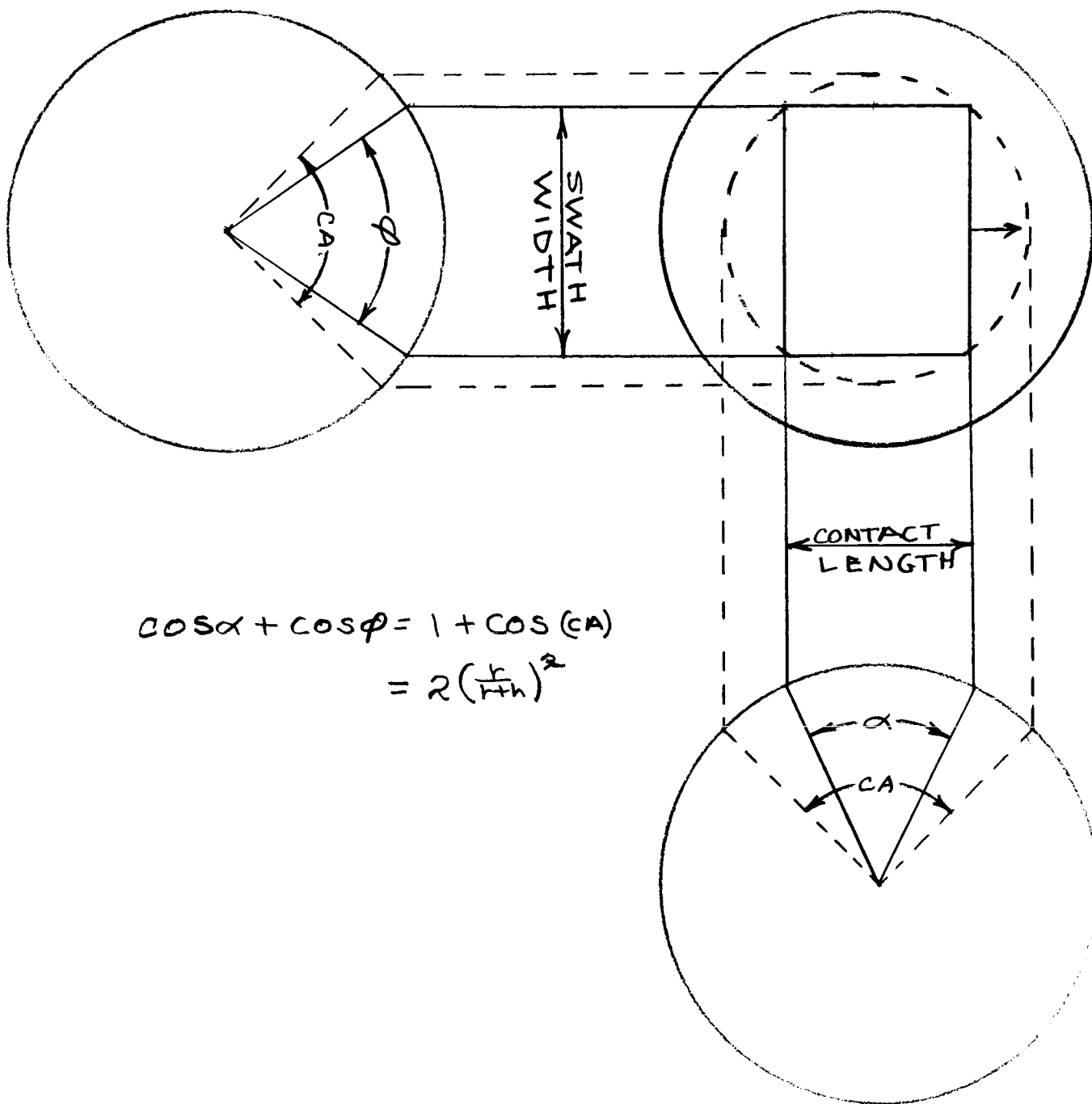

Fig. B-9 Effective Satellite Coverage

$$\cos \alpha + \cos \varphi = 1 + \cos \theta \quad (CA)$$

or:

$$\cos \alpha + \cos \varphi = 1 - \cos \theta$$

with the obvious limitation

$$\alpha \text{ \& } \varphi \leq CA$$

Contact Time (CT) can be easily obtained using the expression:

$$CT = \left(\frac{\alpha}{360} \right) \tau$$

where τ is the period (Figure 3-4)

The relations between contact length (α), contact time (CT), and swath width (φ) for a 100 Km (60 nm) satellite are shown in Figure B-10.

3.2 Single Satellite Coverage

Figure B-10 can be used to investigate the communications between the Orbiting Lunar Station (OLS) and a surface base. For Earth orbit operations a five minute contact is considered adequate including acquisition time. However, most large Earth based stations are equipped with automatic acquisition and tracking antennas. For lunar operations the need for tracking can be eliminated by the use of omni directional antennas on the surface. The effect of this is considered later in discussion on antenna sizes and gain. For emergency communications, 5 minutes contact time seems adequate. From Figure B-10 a 5 minute contact time provides a swath width (φ) of approximately 35 degrees compared to a maximum of 38.2 degrees, a reduction of approximately 8%. For an equatorial OLS, a minimum contact of 5 minutes with surface bases within the band of $\pm 17.5^\circ$ latitude from the equator is possible with a period of 118 minutes. Similarly a polar OLS can communicate with a surface base within 17.5° latitude of either pole.

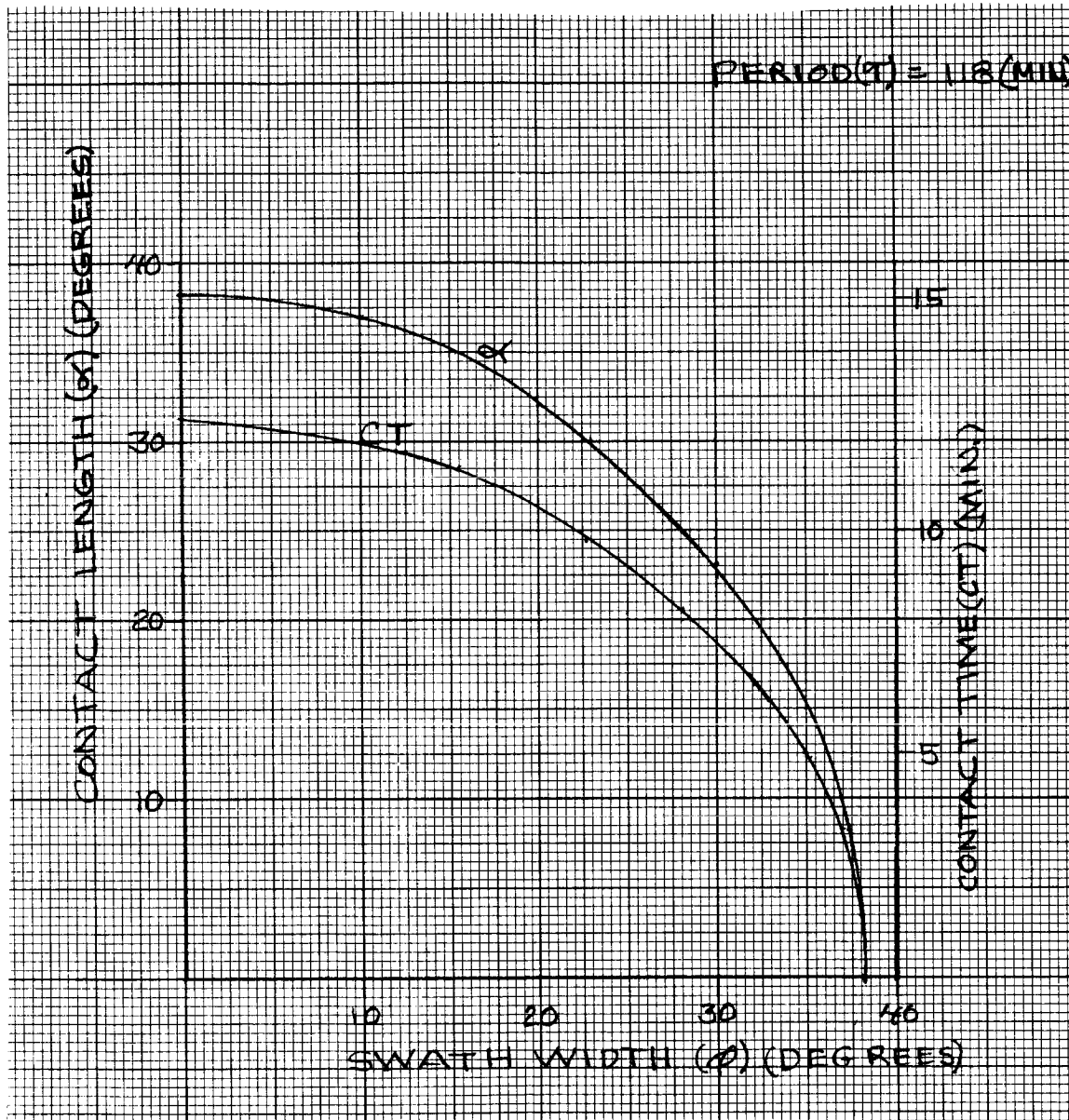

Fig. B-10 Contact Length (α) & Contact Time (CT) vs Swath Width (ϕ)
100 KM (60 nm) Lunar Satellite

For the more general case of contact between a polar OLS and the lunar surface, an equatorial site has the longest periods of no contact caused by the surface base moving out of the OLS track due to the moon's rotation. The contact times or periods within the swath width were given previously on Figure B-8. As shown above, these swath width or cross-track times should be reduced by about 8% to allow for a minimum 5 minute contact time each revolution. At higher altitudes the correction is less because of the increase in contact angle and periods with altitude.

3.3 Multiple Satellite Coverage

The curves of Contact Length (α) vs swath width (ϕ) for constant altitudes from 100 to 7000 kilometers are plotted on Figure B-11. The previous discussion on a single satellite applies except that the contact times increase with altitude as given previously by the expression:

$$CT = \left(\frac{\alpha}{360} \right) \mathcal{T}$$

where \mathcal{T} is the period (Figure B-7).

Similarly for time across swath width

$$CT = \left(\frac{\phi}{360} \right) (14) \text{ (days)}$$

For any altitude, the curves in Figure B-11 provide the tradeoff between contact length (α) and swath width (ϕ). From Figure B-8 it is obvious that for a single satellite the longest blank in contact or No. Contact Time (NCT) is due to the rotation of the Moon. This period ranges from 2 days at high altitude down to 11 days at 100 kilometers. On the other hand, the No Contact Time due to a satellite's rotation in its orbit is 2 to 12 hours (Figure B-8). A delay of hours may be acceptable for emergency communications, but a period of days is not. To eliminate the cross track delay, single

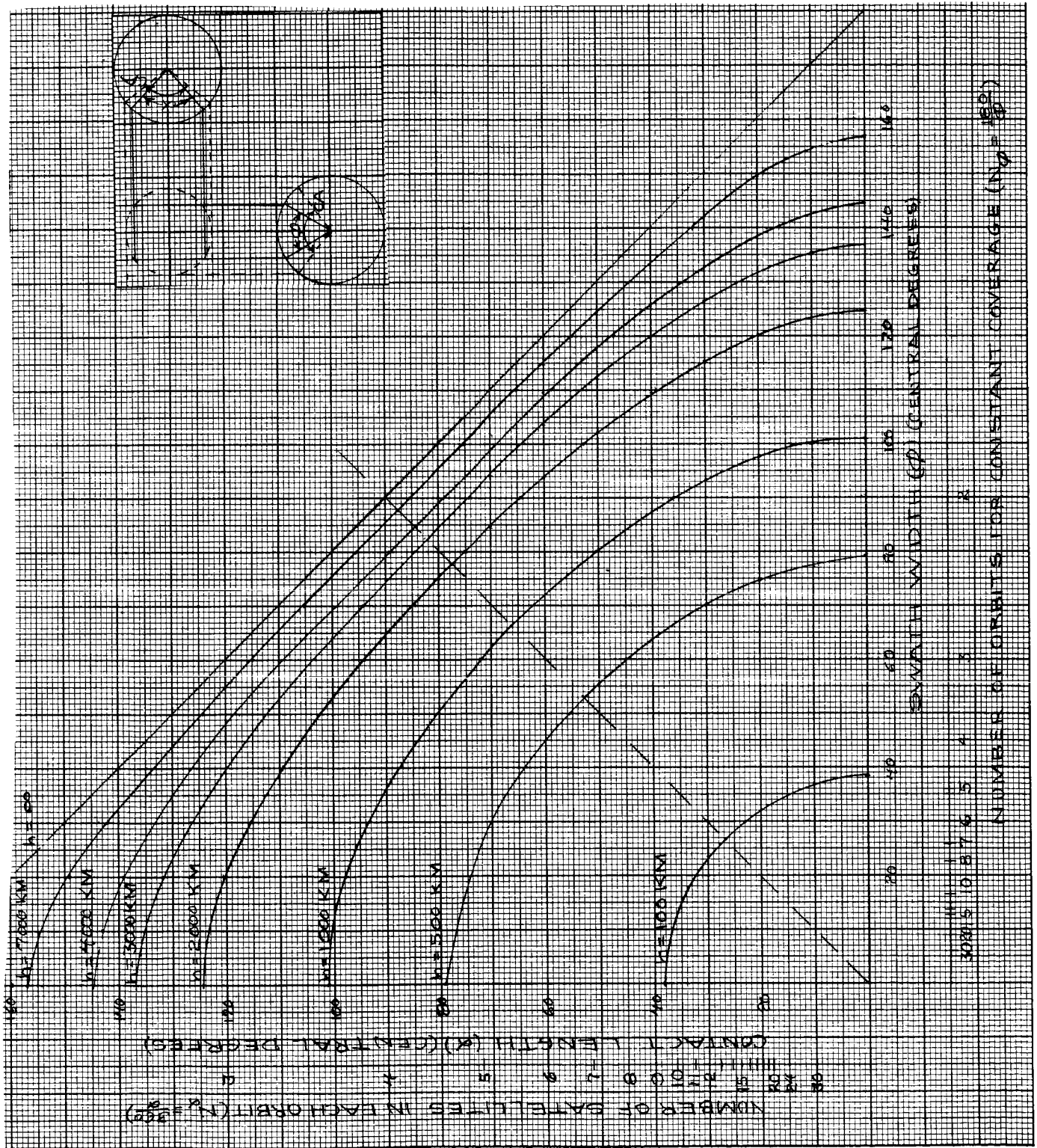

Fig. B-11 Lunar Satellite Coverage

satellites in multiple orbits could be employed. The integral number of orbits (N_{ϕ}) required to provide 360° coverage around the equator for polar orbits is shown beneath the swath width (ϕ) scale on Figure B-11. Note that with 2 satellites in orbits 90° apart at an altitude of 1000 (Km) or more would provide one contact of 35 degrees or more each period. For 1000 Km the maximum gap in communication time would be a little over 3 hours.

To provide continuous coverage of an equatorial base, the integral number of satellites (N_{α}) required in each orbit can be determined as a function of contact length (α). For a fixed altitude, the minimum number to provide continuous coverage of the lunar surface lies as close to the dashed diagonal as possible. On the other hand, for a fixed number of orbits (N_{ϕ}) and satellites in each orbit (N_{α}), the minimum altitude to provide continuous coverage at the equator can be interpolated from the constant altitude curves.

In discussing continuous coverage for polar orbits, the criteria of equatorial locations has been used, because at the equator the degrees of longitude covered is equal to the swath width (ϕ). The swath width (ϕ) is defined as a central angle and expressed in surface degrees. Consequently, its value is constant, but the degrees of longitude spanned is a function of the latitude of the local vertical being equal to ϕ at the equator and approaching 180 degrees as a limit at the pole.

For a polar orbit the actual degrees of longitude spanned by a swath width (ϕ) can be determined by the expression:

$$\tan \frac{LS}{2} = \frac{\tan \frac{\phi}{2}}{\cos (\text{Lat})}$$

where LS = Longitudinal Swath
 ϕ = Swath width
 Lat = Latitude of local vertical

The Longitudinal Swath vs latitude as a function of Swath width (ϕ) is given on Figures B-12. To provide continuous coverage for polar satellites the longitudinal swath width of N equally spaced orbits must equal or exceed 180 degrees. As shown in Figure B-12 the increase in Longitudinal Swath is minimal below 40 degrees latitude particularly for low altitude satellites with their attendant narrow swath widths (Figure B-11).

3.4 Horizon Limitations

The geometric relations for contact at the horizon are shown on Figure B-13. The dashed lines present the theoretical arrangement on the left of the diagram. For earth orbiting satellites a minimum elevation angle (ϵ) above the horizon must be allowed for before contact can be established. A general rule of thumb is to allow a minimum elevation angle of 5 degrees in determining acquisition and fade times. No similar figure is available for lunar surface to orbit communications, but it will be considerably less for three reasons:

1. Lack of atmosphere.
2. Lunar radius is only 27% of the earth radius.
3. Omni-directional antennas will be used on the lunar surface to eliminate the acquisition and tracking of the satellite (See Antenna discussion).

The major effect of using a finite elevation angle on the previous calculations is to reduce the contact angle (CA) by the factor of twice the elevation angle (2ϵ). In Figures B-11 and 12 this lowers the α vs ϕ curves by the same amount equivalent to flying the satellite at a lower altitude. For reasons considered above, this angle will be much less than 5 degrees and is mentioned for the sake of completeness.

3.5 Satellite Antenna Size and Gain

The required beam width of the satellite's directional antenna is a function of the altitude according to the expression:

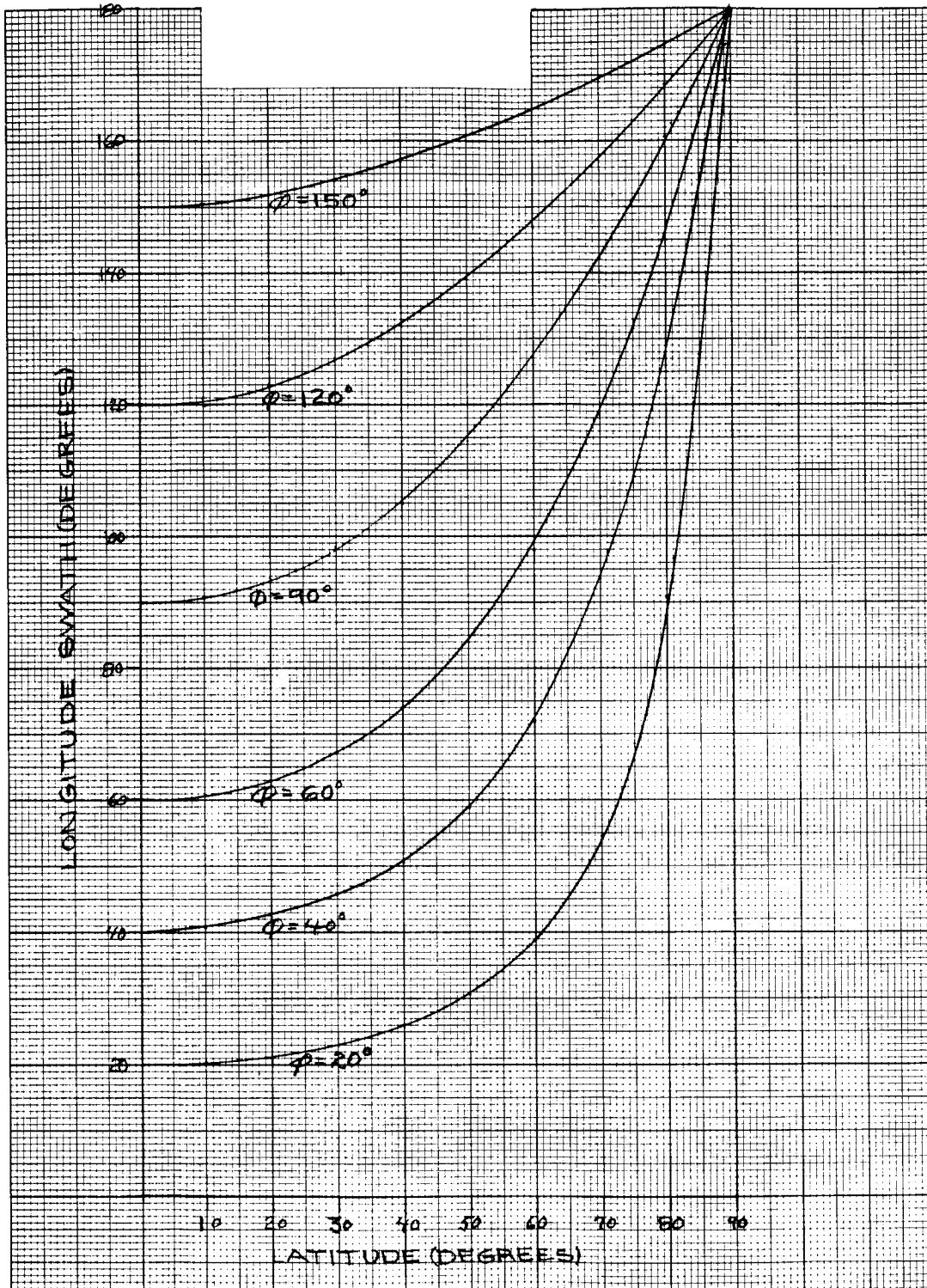

Fig. B-12 Longitude Swath vs Latitude

$$\frac{\sin(90 + \epsilon)}{r+h} = \frac{\sin(\theta'/2)}{r}$$

$$\sin(\theta'/2) = \frac{r}{r+h} (\sin 90 + \epsilon)$$

$$\sin(\theta'/2) = \frac{r}{r+h} (\cos \epsilon)$$

$$\# \quad CA'/2 = 180 - (90 + \epsilon) - \frac{\theta'}{2}$$

$$CA' = 180 - \theta' - 2\epsilon$$

$$\Delta CA = CA - CA' = 180 - \theta - 180 - \theta' - 2\epsilon$$

$$\theta \cong \theta'$$

$$\Delta CA \cong -2\epsilon$$

$$\frac{\sin(90)}{r+h} = \frac{\sin(\theta/2)}{r}$$

$$\sin(\theta/2) = \frac{r}{r+h}$$

$$\# \quad CA/2 = 90 - \theta/2$$

$$CA = 180 - \theta$$

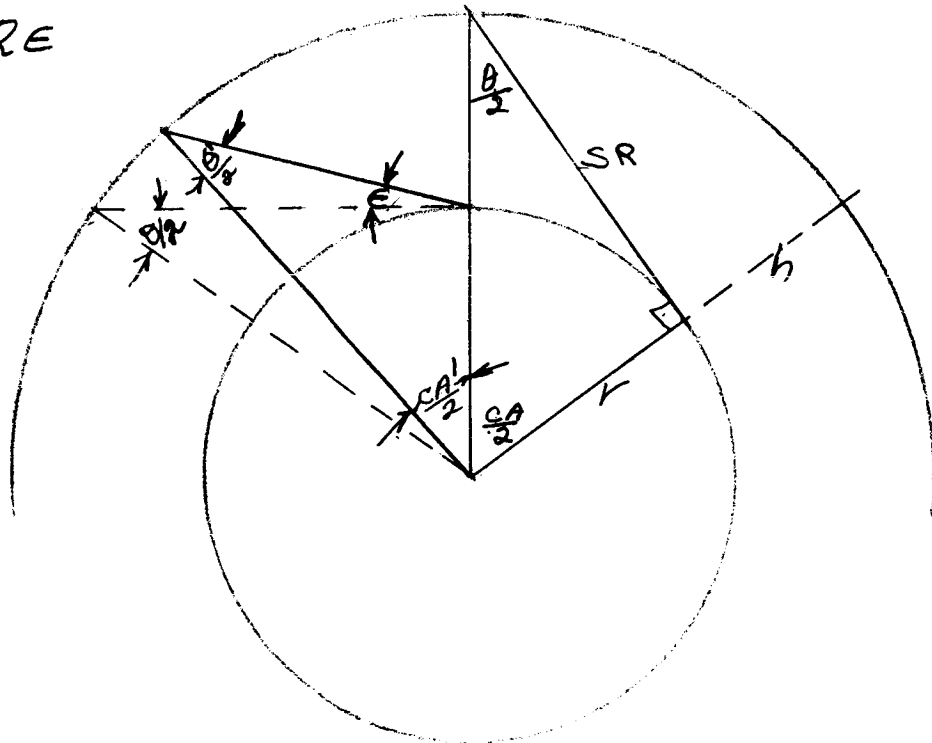

Fig. B-13 Effect of Horizon Limitations

$$\theta = 2 \sin^{-1} \left(\frac{r}{r+h} \right)$$

where h = altitude (Km)

r = lunar radius = 1738 (Km)

The beam width is sufficient to cover the area of the lunar surface in view at any time from the satellite.

The gain (G) of a parabolic antenna is a function of beam width and is related by the expression:

$$\theta^2 = \frac{27000}{G}$$

Consequently, the satellite's antenna gain (G) is a function of altitude and independent of frequency if the beam width criteria applies.

However, the gain (G) of a parabolic antenna is a function of frequency (f) and diameter (D) according to the expression:

$$G = 5.5 \times 10^{-6} f^2 D^2$$

where f = frequency (MHz)

D = diameter (ft)

The diameter can be expressed as a function of beam width and frequency:

$$\theta^2 = \frac{27000}{G} = \frac{49 \times 10^8}{f^2 D^2}$$

$$\text{or } \theta = \frac{7 \times 10^4}{f D}$$

$$D = \frac{7 \times 10^4}{f}$$

$$\text{and } \theta = 2 \sin^{-1} \left(\frac{r}{r+h} \right)$$

Consequently, the required diameter is a function of frequency (f) and altitude (h).

The gain for the satellite antenna (G_{SA}) in (db) ($10 \log G_{SA}$) and the diameters for S-band (defined as 2 GHz) and VHF (defined as 300 MHz) are plotted on Figure B-14 as a function of altitude. For S-Band below 4000 (Km) the diameter is less than a foot which is not practical. Use of larger antennas results in a narrower beam width than required and necessitates tracking of the surface station by the satellite at the lower altitudes. The other alternative is to use omni directional antennas with the resultant loss of gain. Because of this physical beamwidth limitation for S-Band antennas, the S-Band is not desirable for lunar satellite communication at lower altitudes. Also, the path losses are greater for S-Band than VHF as shown in the next section.

It is this same antenna characteristic that favors S-Band over VHF for long distances, e.g., Earth/Moon, Moon/libration point, where narrow beam/high gain requirements result in excessive diameters for VHF antennas.

Propagation Loss

The free space propagation loss is a function of frequency and distance as given by:

$$L_p = \left(\frac{4\pi R}{\lambda} \right)^2 = \left(\frac{4\pi}{C \cdot 10^6} \right)^2 R^2 f^2 = 1760 R^2 f^2$$

where C = speed of light = 3×10^8 (Km/sec)

R = Range (Km)

f = frequency (MHz)

The path loss L_p is plotted on Figure B-15 versus altitude using the maximum slant range corresponding to altitude. There is a constant 17 db difference between S-Band and VHF due to the frequency term in the above expression. The transmission loss consisting of path loss minus satellite antenna gain is also plotted. As mentioned previously, the antenna gains below

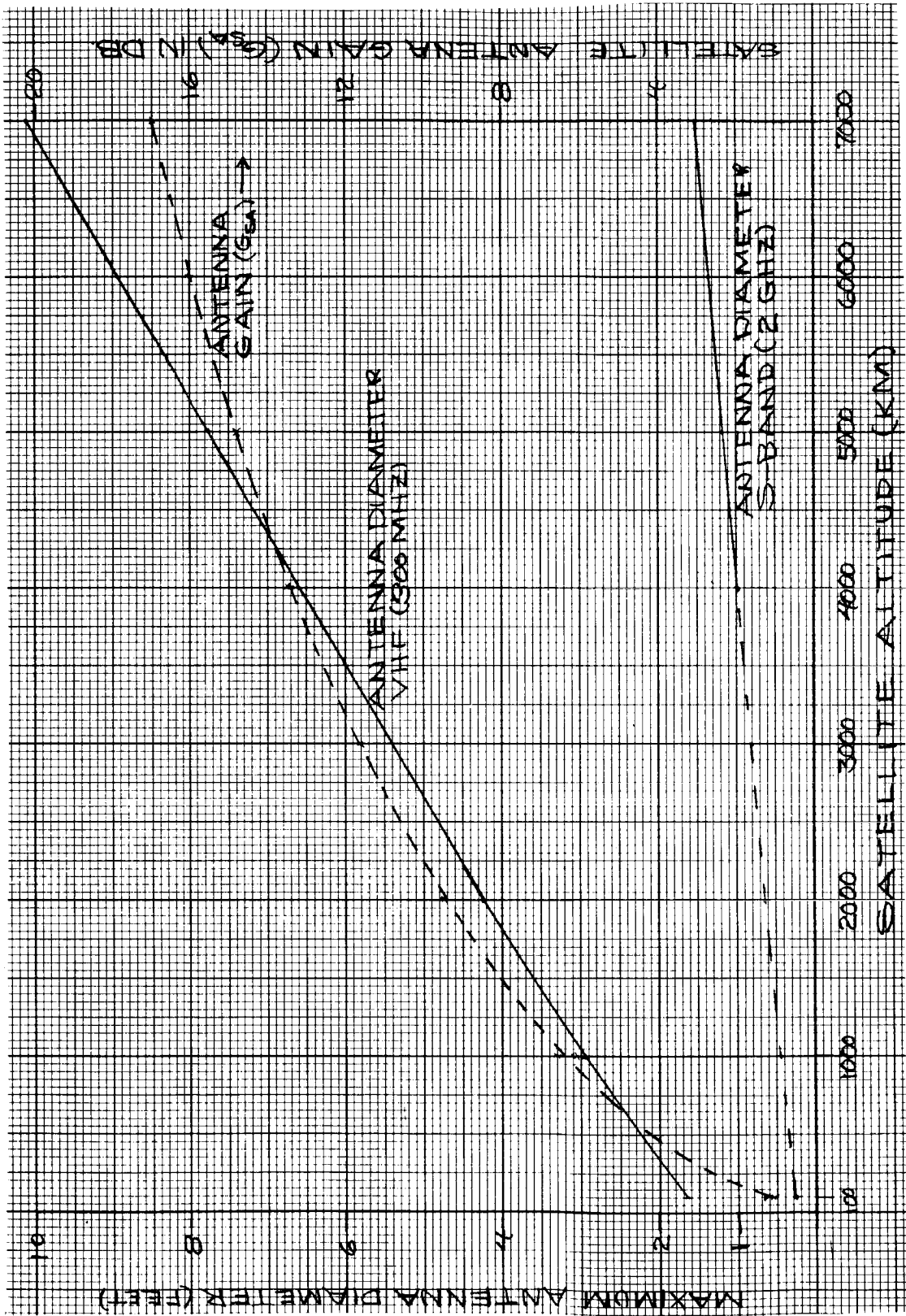

Fig. B-14 Maximum Satellite Antenna Diameter and Antenna Gain

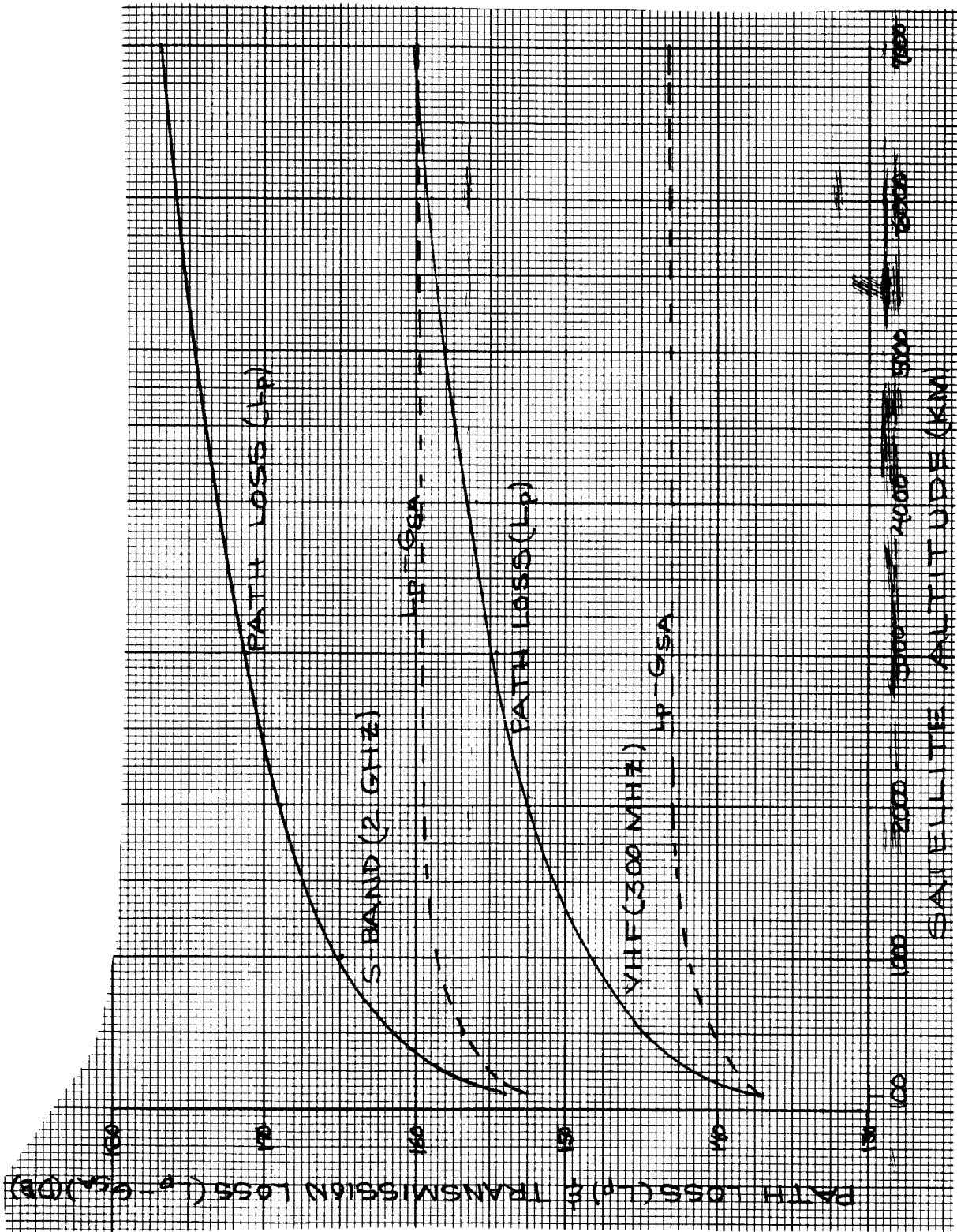

Fig. B-15 Satellite Transmission Loss vs Altitude

4000 (Km) for S-Band are rather academic for parabolic antennas. Figure B-15 demonstrates a 17 db advantage of VHF over S-Band when considering antenna gain and propagation loss of lunar satellites.

The most significant factor is that above 1000 (Km) the choice of altitude does not affect power requirements for VHF. This is theoretically true for S-Band also, but practical limitations interfere. Consequently, the criteria for altitude selection can be limited to operational considerations such as coverage, deployment, and maintenance. Coverage as a function of altitude has been explored in detail in a previous section.

3.6 Satellite Transmitter Power

A detailed analysis of individual communication link factors such as equipment losses, cabling losses, noise factors, and modulation techniques which all have an effect on required transmitter power is not appropriate nor would it be very valid when 10 years of development must be considered. However, transmitter power is a dominant factor in comparing alternate approaches. In the following analysis a range of power is developed based on present equipment and techniques for VHF (300 MHz). S-Band requirements are not included because of the considerations of additional path loss and antenna size.

Transmitter power may be expressed as the algebraic sum of the following factors in decibels (db):

$$P_T = (L_p - G_{SA}) + L_E + N_o + BW = S/N$$

P_T is required transmitter power in dbw = $10 \log P_T$ (watts)

$(L_p - G_{SA})$ is the previously defined transmission loss consisting of pathloss minus satellite antenna gain. (143 db)

L_E is the combined losses due to cabling, modulation, omni directional antenna at the surface. (5 to 10 db)

N_o is the receiver noise spectral density in dbw per hertz referred to receiver terminals conservatively estimated at -190 dbw/hertz based on LM and CSM.

BW is the predetection bandwidth at the receiver which ranges from 2 KHz to 8 KHz for voice (33 to 39 db). For telegraphy BW is in the order of 10 hertz or 10 db.

S/N is the signal to noise ratio of the received signal and is a measure of clarity or error rate. (10 to 15 db).

Minimum/Maximum Power can be based on taking the optimum value for each of the above factors for voice communications.

		<u>Min P_T</u>	<u>Max P_T</u>
$(L_p - G_{SA})$	=	143	143
LE	=	5	10
N_o	=	-190	-190
BW	=	33	39
S/N	=	<u>10</u>	<u>15</u>
P_T	=	1 dbw	17 dbw
		1 watt	50 watts

For telegraphy, P_T is much lower because the bandwidth (BW), is only 10 hertz or 10 db resulting in transmitter powers of -22 and -12 dbw or 8 and 18 dbm (decibels in milliwatts) corresponding to 6.3 and 63 milliwatts.

Based on the foregoing a transmitter output power of 10 watts is a conservative allowance for providing a lunar satellite/surface link for emergency communications.

4.0 Microwave Surface Relays

4.1 Application

Line-of-sight microwave communications can be used for the following surface-to surface links:

- 1) Base to roving astronaut,
- 2) Roving astronaut to roving astronaut,
- 3) Base to remote experiment instrumentation,
- 4) Roving vehicle to roving astronaut,
- 5) Base to remote base.

The maximum distance for line-of-sight communications between two astronauts for five-foot-high transmit and receive elements is about 2.4 n.mi. over a smooth surface. Increased coverage for surface communications can be obtained by erection of remote repeater towers or surface units strategically located on top of local elevated topographical features. The use of this type of system allows communications which are independent of local terrain irregularities.

4.2 The use of VHF, UHF, or microwave relay repeaters for surface-to-surface remote communications should be considered. One concept for a microwave repeater system has the nominal repeater parameter values of ten cubic feet, ten earth pounds and requires about fifteen watts of prime power. This system can be used to maintain continuous or time-shared channels for voice, status telemetry, and location telemetry. A digital modulation system is assumed for efficiently combining multiple data sources, i.e., voice, telemetry and PRN ranging.

A voice channel can be digitized with acceptable quality at 20 kbps. Therefore, with 4 kbps for a nominal 1000 foot ranging accuracy and 1 kbps for telemetry and multiplexer address data, a total of 25 kbps is assumed adequate for a typical communication channel.

4.3 Link Calculations

The transmitter-receiver power requirements for a nominal free-space path of ten miles are shown in the following table. These requirements are conservative and merely demonstrate a concept.

Assume:

- 1 GHz carrier frequency
- Regenerating relay
- Differentially coherent PSK data demodulator
- Bit error rate = 10^{-4}

Microwave Relay Power Example

Manpack transmitter power at antenna (30 milliwatts)	+14	dBm
Manpack antenna gain	0	dBm
Free Space Loss	-117	dB
Polarization and Misc. Losses	-3	dB
Relay antenna Gain	+3	dB
<hr/>		
Receiver Signal Strength	-103	dBm
Receiver Noise Power Density (5 dB Noise Figure)	-169	dBm/Hz
Receiver Signal-to-Noise Density Ratio (S/N_0)	+66	
Required S/N for DPSK (25 kbps, 10^{-4} Error Rate)	56	dBm
System Margin	+10	dB

Trades can be made in the selection of system parameters, e.g., transmitter power or receiver sensitivity can be traded for antenna gain if constraints on package size are imposed.

4.4 Power Supply Requirements

Requirements for a repeater power supply are discussed in the following paragraphs. It is possible to locate the power supply remote from the repeater for easier access by connecting the units with a cable.

The requirements for the electrical power supply may be summarized as follows:

- Power for receiving and transmitting -- 15 watts
- Maximum duration of continuous and transmitting -- 50 hours
- Time of day -- any time during lunar day or night
- Location -- any place on lunar surface
- Life -- 10 years

4.5 Radioisotope Thermoelectric Generator (RTG)

The electrical power source judged most applicable to the requirements is a radioisotope thermoelectric generator, RTG, fueled with Plutonium 238 which could be used on the lunar surface as is the present Apollo Lunar Surface Experiment Package (ALSEP), which uses the SNAP-27 RTG.

It is estimated that a 15 watt RTG would weigh in the neighborhood of 25 pounds. The fuel elements could be contained within the RTG during transport or all 15 Pu-238 fuel capsules could be transported within the same radiation shield and placed in each RTG on the moon's surface. In that way the weight of each RTG might be reduced to 20 pounds.

Pu-238 is selected because of its 87 year half-life, where less than 8 percent of the original fuel capability will have decayed in ten years. If a thermoelectric conversion efficiency of 5% is used, with allowance for degradation from an initially higher value, we then would need 325 thermal watts of fuel. The AEC has projected the cost of Plutonium 238 at from \$500 to \$700 per thermal watt. At that price, the fuel per communications link would cost in the order of \$200,000 but the fuel is recoverable.

The RTG should present no thermal problem since the very low cold sink temperature during the lunar night should improve operating efficiency; also the maximum cold sink temperature during the lunar day can be effectively controlled by a reflective sun shield. The ALSEP RTG was expected to see a cold sink temperature range of 170 to -280 deg. F.

Life expectancy of the RTG is limited by the thermoelectric couples, which may be susceptible to vaporization if the inert gas seals fail and expose the couples to the combination of high temperature and hard vacuum. In any case the failure mechanism should be gradual, allowing for manual replacement of the thermoelectric generator. Life of ten years may be an attainable goal, but it may be well to plan on one to three generator replacements in that time period, for each communications link.

4.6 Solar Array - Battery Supply

A solar array-secondary battery system was considered, with the nickel-cadmium batteries storing energy for a potential 50 hour operational period during the lunar night. Since battery operation is temperature dependent a minimum temperature of 0 deg.F. was considered, which would be maintained by battery powered resistance heaters. Super insulation of the batteries is necessary, since an allowable heat leak of only 0.15 watts/sq. ft. was calculated from the following assumptions:

Power to communications link 15w (50 hrs.) =	750 wh
Heat loss made up by heaters,	
6 sq. ft. (.15 w/sq. ft.) (320 hr) =	<u>288 wh</u>
Total power	1038 wh
Battery depth of discharge	75%
Battery power density	14 wh/#
Battery surface area	6 sq. ft.

The above battery would be estimated to weigh 100 pounds. However, the lunar day operation would require removal of the super insulation from the battery to allow radiation of heat generated during battery charging. It is felt that any active means of thermal control is undesirable from a reliability standpoint; therefore the battery-solar array system is not considered as an attractive alternate. Battery operational temperature during the lunar day could be easily controlled by a sun shield. The solar array portion of the system should offer few problems; however, the battery charge controller is an electronics device which would have to be carefully designed to incorporate adequate reliability.

4.7 Solar Array - Fuel Cell Supply

Also considered was a solar array-regenerative hydrogen-oxygen fuel cell system, but the technology is not being advanced at a very rapid rate which makes it difficult to project long life capability or availability. The thermal environment is all important as in the battery case; however, a higher temperature limit should be practical which might permit passive thermal control. The endothermic charging (electrolysis of water) occurs in the daylight and the exothermic discharge (fuel cell combination of hydrogen and oxygen) occurs at night; this is consistent with the environment and makes passive thermal control a feasible possibility.

On electrolysis hydrogen and oxygen gas are generated and must be stored. This means pressure vessels, operating up to 500 psi, would be required. The long-term storage of gases is a problem since the smallest leak would degrade the system. A minimum system weight would be estimated at 50 pounds based on an ideal thermal design where heat is conserved to an extent eliminating heaters. Since an ideal system is unlikely, heater power requirement could easily double the system weight to 100 pounds.

Relative system costs aside from radioisotope costs, are not deemed significant because the cost of delivery to the lunar surface overshadows basic hardware cost for any of the systems.

In summary, the RTG is the lightest weight system and is the least affected by the thermal environment; therefore it is selected for the tentative baseline design.

REFERENCES
(Appendix B)

1. "Initial Concept of Lunar Exploration Systems for Apollo" The Boeing Company, March 1964, Volume III, Part 2, NASA CR-55764
2. Communications and Control, Lunar Exploration Systems for Apollo, Volume 2, Technical Report, Westinghouse Defense and Space Center, March 1965, NASA CR 63176.

APPENDIX C
TUMBLING VEHICLE ESCAPE/RESCUE ANALYSIS

One complication that may occur whenever a spacecraft (tug, propellant depot, PTV, orbital station, AMU, EVA crewman) sustains a critical failure involving guidance, attitude control, reaction control nozzles, or depressurization is that tumbling may occur. For analysis purposes it is assumed that any tumbling will occur about one of the three major axes and that the desired docking or spacecraft attachment mechanism can be located on any one of the three axes. An added complication is that radiation levels from a nuclear propulsion powered vehicle (such as a nuclear shuttle) may fix a minimum range at which the rescue vehicle must be able to match the nuclear shuttle vehicle tumbling motion sufficiently to remain within the nuclear shuttle safe radiation cone. Figure C-1 presents some of the pertinent details of a typical design for a nuclear shuttle that could be used as a prime transport vehicle (PTV). The normal docking port of this vehicle is located at the forward end of the vehicle and within the safe radiation shielded cone.

Approach

The critical factors that determine the capability for escape/rescue from a tumbling spacecraft are:

- a. tumble rate of the disabled vehicle
- b. acceleration forces on crewmen (both stranded and rescue crewmen) must be less than approximately 2.5 gs for time spans longer than about 10 seconds
- c. minimum safe range due to physiological radiation limits

A typical non-nuclear tumbling vehicle rescue situation is presented in Figure C-2, and C-3. The stranded vehicle is tumbling at a fixed ω . As the rescue vehicle moves into a position in the plane of rotation of the crew compartment and docking port of the stranded vehicle it must maneuver so that the rotational rate of the rescue vehicle phases with that of the

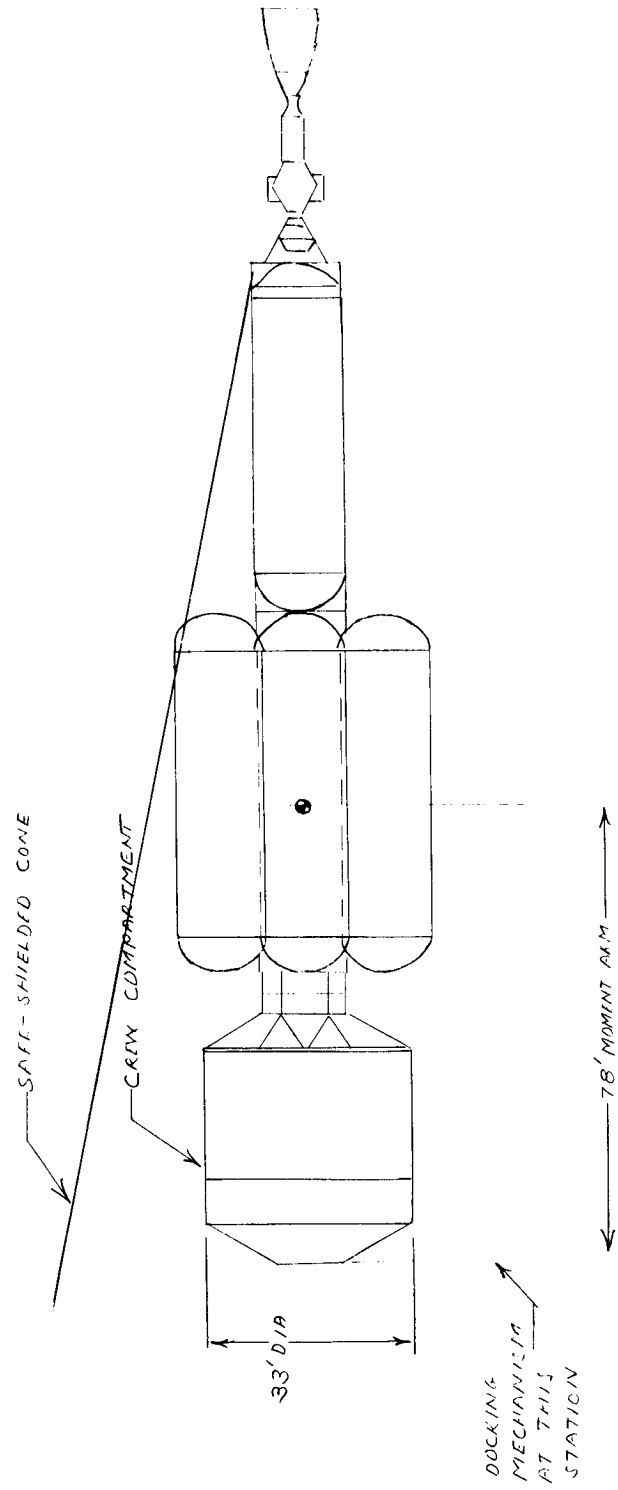

Fig. C-1 Typical Nuclear Prime Transport Vehicle

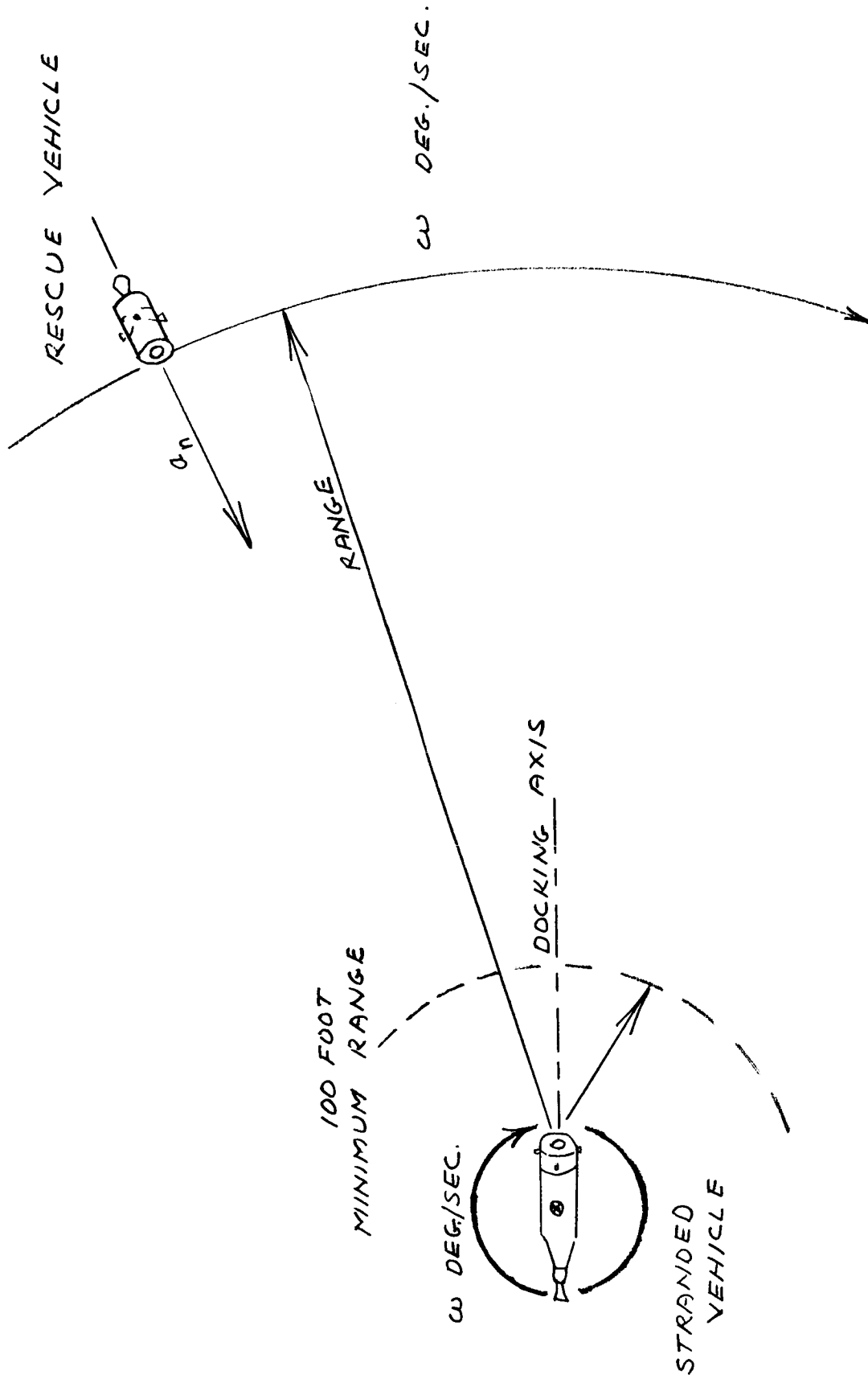

Fig. C-2 Non-Nuclear Tumbling Vehicle Geometry

stranded vehicle. The rescue vehicle must then reach a final position relative to the stranded vehicle on its docking axis, and phased with its rotational rate by the time the rescue vehicle reaches the minimum range of 100 feet.

An additional restriction is that the normal acceleration to which the rescue vehicle is subjected cannot exceed approximately 2.5 gs for time-spans beyond about 10 seconds.* The stranded crew is also subject to this restriction, but since the normal acceleration force is a function of both tumbling (rotational) rate and range it follows that the rescue vehicle will always be subject to a higher normal acceleration since it will always be at a longer range from the center of rotation. The center of rotation is at the center of gravity of the tumbling stranded vehicle. Therefore, the acceleration force on the rescue vehicle can be used as the limiting case.

Two general cases will now be presented. The first case that will be considered will be that of a disabled non-nuclear spacecraft that is tumbling at some constant rate. The second case will be similar except that it will be assumed that the tumbling spacecraft is a nuclear shuttle.

Case 1 - Non-Nuclear Tumbling Manned Spacecraft

For the purposes of this study it is assumed that the dimensions and center-of-gravity location of the tumbling non-nuclear powered spacecraft are as indicated in Figure C-1. Previous studies* have determined preliminary maximum rotational rates and axes for various conditions. The rates quoted in the reference** ranged from 18° to 24° /sec., depending on the particular conditions causing the vehicle to tumble.

*refer to Figure C-3

**General Electric Co., SS-TK-060-4,
Preliminary Analysis of Escape from a
Tumbling Space Station, June 1970

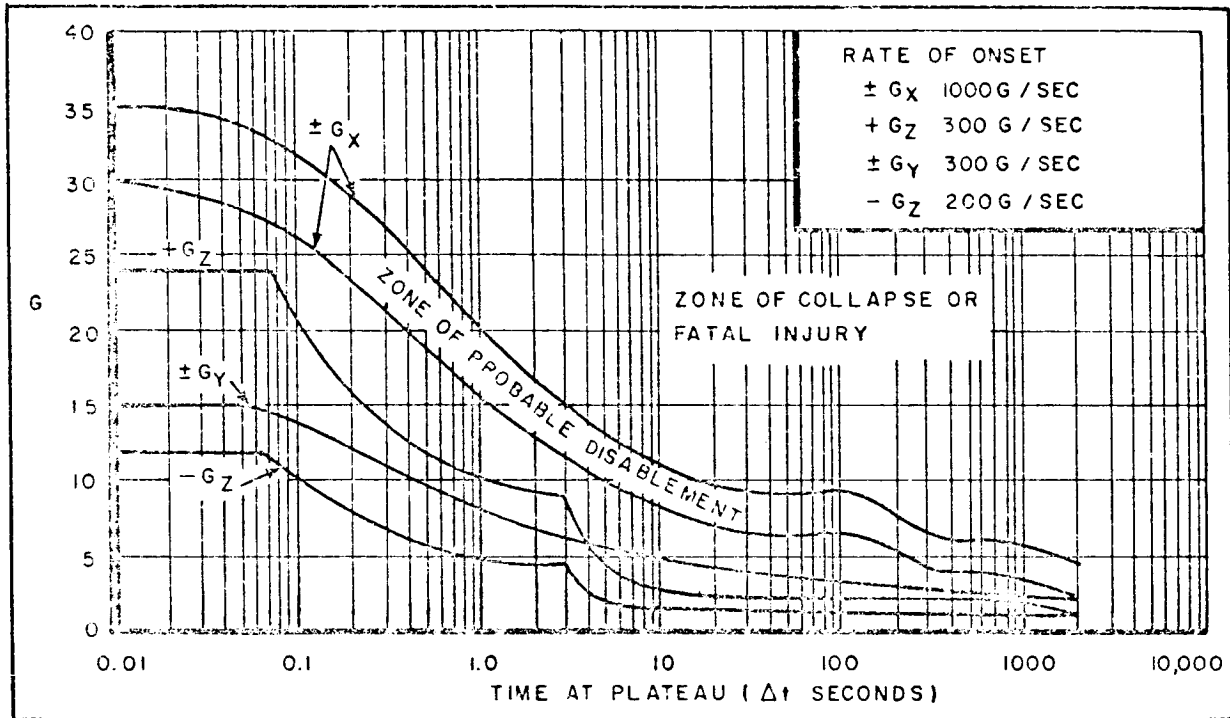

Taken from AFSC Design Handbook
 Series 1-0
 DH 1-3 Personnel Subsystems

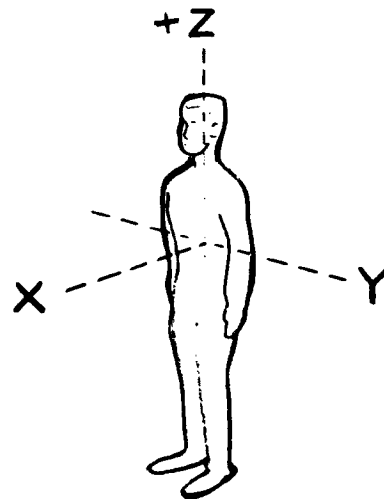

Fig. C-3 Acceleration Limits of Human Tolerance

For the non-nuclear tumbling vehicle there is no range restriction on the rescue vehicle relative to the stranded vehicle other than an operational minimum range based on docking maneuver requirements. A reasonable minimum is 100 feet. This minimum range is measured between the stranded vehicle docking port and the docking port on the rescue vehicle.

The rescue vehicle must match the angular motion of the stranded vehicle and be aligned with its docking axis by the time the rescue vehicle reaches a range of 100 feet from the stranded vehicle's docking port.

Figure C-4 presents the range of stranded vehicle tumbling rates for which rescue can be attempted without exceeding the 2.5 g crew acceleration limit. Note that for the PTV example sized in Fig. C-1 (giving a 178 foot rotational radius) the tumbling rate limit is approximately 40° second. At this limiting tumble rate the rescue vehicle can phase with the stranded vehicle tumble rate, align itself along the docking axis then move along this axis at a slow closing velocity of 1 foot per second or less, and not exceed the 2.5 g limit.

Once docking has been accomplished the rescue vehicle must use its attitude control and reaction control subsystems to stop the tumbling motion or at least to reduce it to a low level. The rescue crew could then proceed with the rescue operation.

Case 2 - Nuclear Tumbling Manned Spacecraft

A typical nuclear tumbling vehicle rescue situation is presented in Figure C-5. The stranded nuclear vehicle is tumbling at some fixed rate, ω . The intensity of the radiation level associated with the nuclear vehicle, NERVA type engine is a function of the time-span since shutdown and the range to the NERVA engine. The nuclear engine internal shield configuration results in a radiation-free cone that includes the crew compartment and extends indefinitely in range. Since the radiation

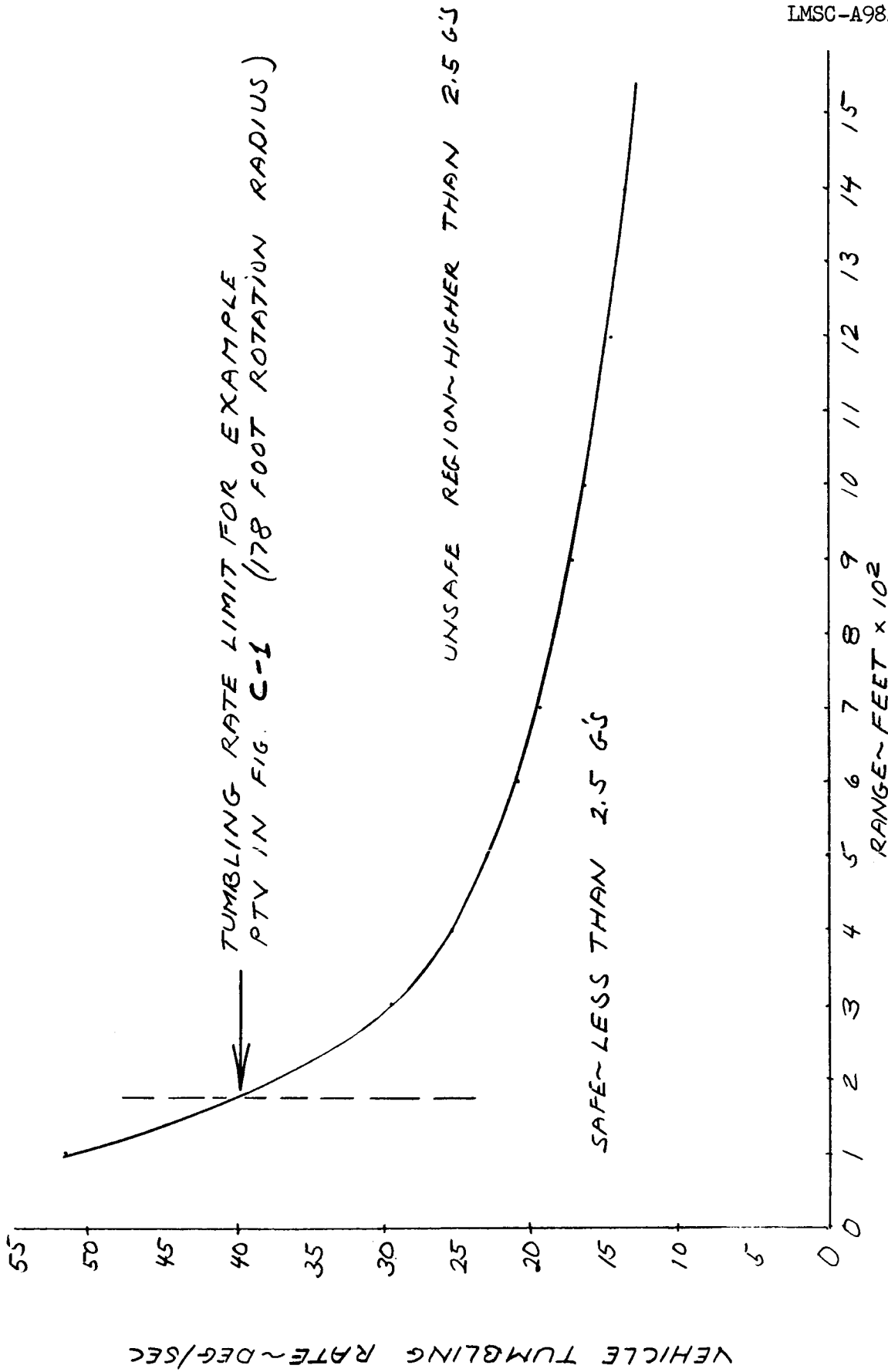

Fig. C-4 Non-Nuclear Stranded Vehicle Tumbling Limits for Rescue

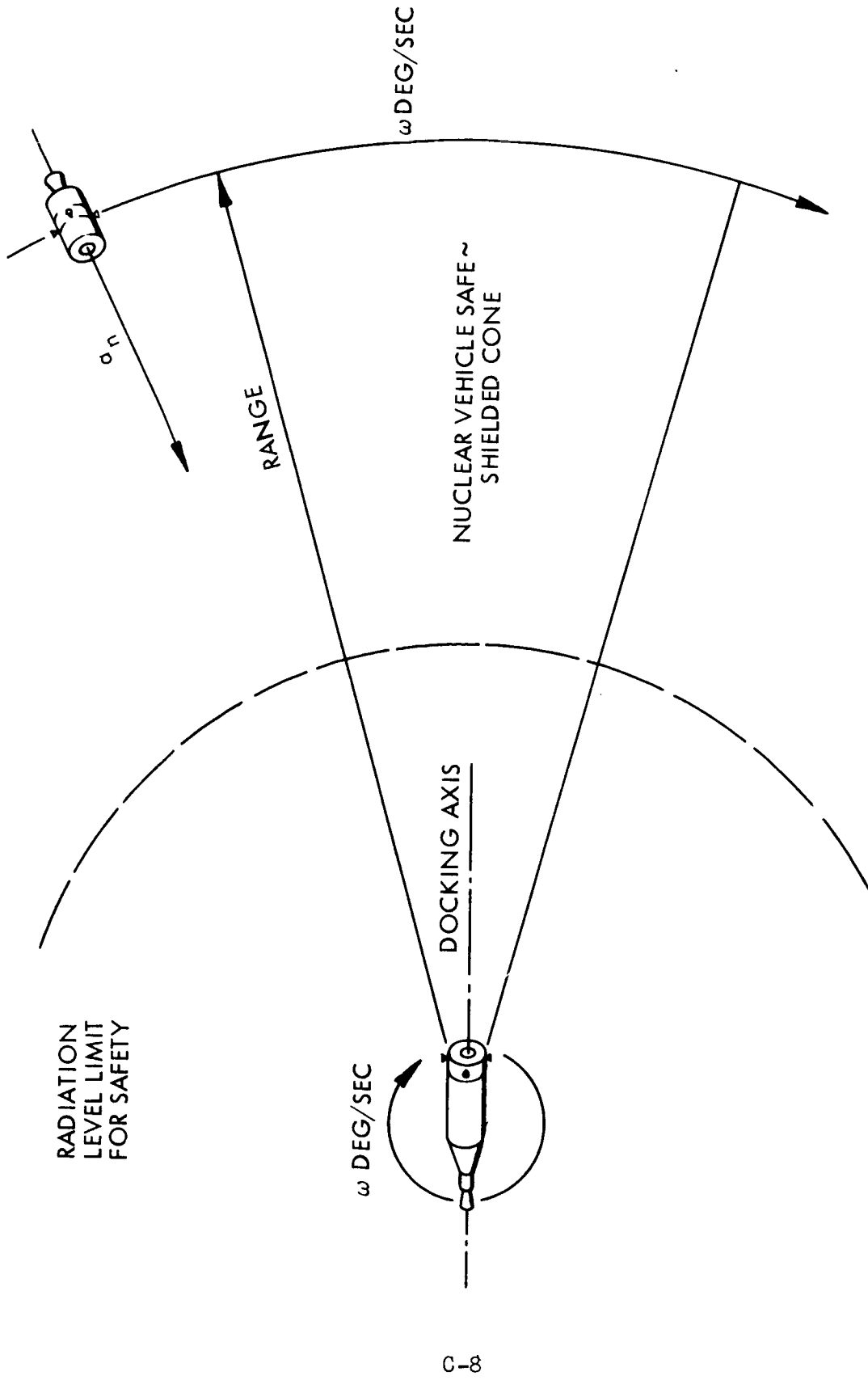

Fig. C-5 Nuclear Tumbling Vehicle Geometry

energy after NERVA shutdown consists primarily of gamma radiation, the radiation level at any given range will decay with time.

It follows that a rescue vehicle attempting to rescue crewmen from a stranded, tumbling nuclear vehicle must contend with not only the problems presented in Case 1, but must also face the necessity to accomplish rotational phasing with the tumbling vehicle at a far greater range. The net effect will be, since normal acceleration is a function of both rotational rate and range, that the stranded vehicle tumbling rate at which rescue can be attempted will be lower than that for a non-nuclear vehicle.

Referring to Figure C-6 it can be seen that a rescue vehicle attempting to phase with and dock with a tumbling nuclear vehicle one hour after shutdown of the nuclear engine would be limited to a tumble rate of about $16.5^{\circ}/\text{sec}$. This limit is due to a combination of two limits: (1) 2.5 g's of normal acceleration, and (2) safe radiation level. The acceleration limit is the same as that for the non-nuclear tumbling vehicle. The radiation limit is a function of the elapsed time after nuclear engine shutdown* and the range. In the example presented in this figure a radiation limit of 25 REM/hour was selected. This radiation level occurs at a range of 985 feet 1 hour after shutdown and 190 feet 1 day after shutdown.

The rescue vehicle, for this example, in order to complete a rendezvous and docking sequence one hour after shutdown would be forced to complete the nuclear vehicle rotational rates phasing operating at a minimum range of 985 feet. From this range point the rescue vehicle must move along the docking axis and remain within the nuclear vehicle safe radiation internal shield cone until docking is completed. The additional normal acceleration limit of 2.5 g's results in a rotational rate limit of $16.5^{\circ}/\text{sec}$. Any higher rate and the rescue operation could not be completed.

*refer to Supplemental Data Report #1
Appendix E, MSC 03977

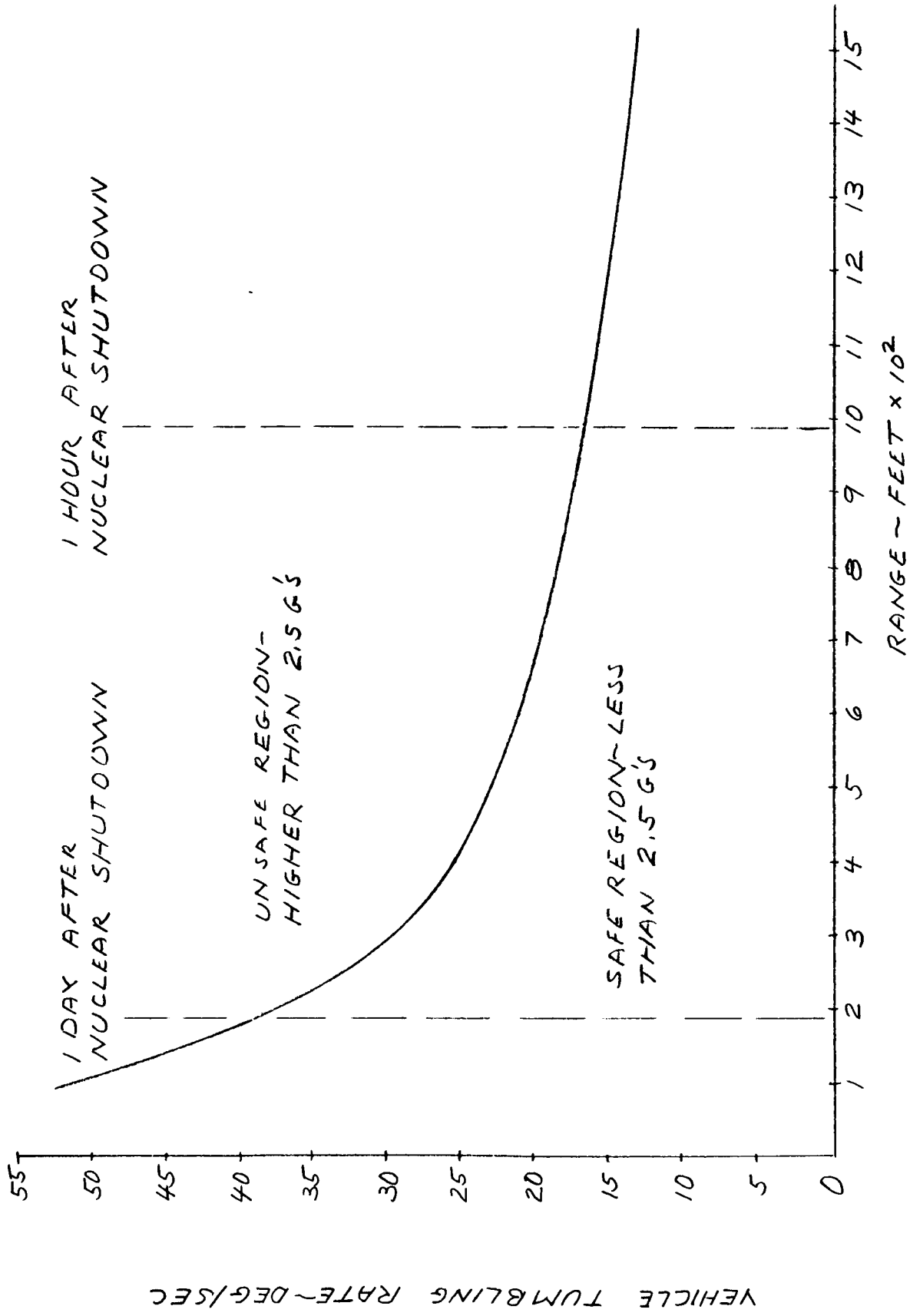

Fig. C-6 Nuclear Stranded Vehicle Tumbling Limits for Rescue

Similarly a rescue attempt one day (24 hours) after nuclear shutdown would be restricted to a rotational phasing range of 190 feet and a rotational rate of about $39^{\circ}/\text{sec}$.

It should be noted that a realistic estimate of a rescue vehicle's capability to phase with a tumbling, stranded vehicle's rotational rate is also dependent on the required thrust-to-weight ratio of the rescue vehicle. For example, in order for a 2800 slug (90,000 lb. gross weight) rescue vehicle to maintain the 2.5 g acceleration required for the phasing maneuver a thrust-to-weight ratio of 2.5 is required.

A more realistic thrust-to-weight ratio would be 1.0 or less. The corresponding maximum rotational phasing capability at the minimum range of 100 feet would be $24^{\circ}/\text{sec}$ at a normal acceleration level of 1 g.

Escape

There are two general stranded vehicle tumbling conditions that make rescue impossible:

- a. the combination of radiation level, tumbling rate and vehicle thrust-to-weight ratio makes it impossible to phase with the tumbling vehicle at the required range.
- b. the stranded vehicle tumbling rate exceeds the phasing capability of the rescue vehicle at any range.

Under the above conditions the stranded crew should separate the crew-compartment from the tumbling vehicle, null out residual rotational rates and await rescue. If the crew compartment has the capability for communications, life support, environmental control, power, attitude control, and Δ velocity the rescue vehicle should then be able to locate, rendezvous with, and dock to the stranded crew compartment and recover the crew.

Fig. C-7 presents some separation data for a crew compartment that separates from a tumbling vehicle at various tumble rates. Notice that even at a tumble rate as high as $55^{\circ}/\text{sec}$. the crew is subjected to an acceleration force less than 1 g.

There are two potential critical problems associated with escape from a tumbling vehicle. The first is that the crew compartment could be struck by a protruding structural member. The second is that separation from a tumbling nuclear vehicle could subject the crew to unsafe radiation levels.

For the first case, a combination of careful location of protruding structural members and providing some Δ velocity capability should make separation safe.

There are two approaches to handling the radiation level exposure problem. The simplest approach is simply to delay the escape-separation maneuver until normal radiation decay results in a decrease to a safe radiation level. The second is to add Δ velocity capability to the crew compartment to decrease the length of time that the crew is exposed to an unsafe radiation level.

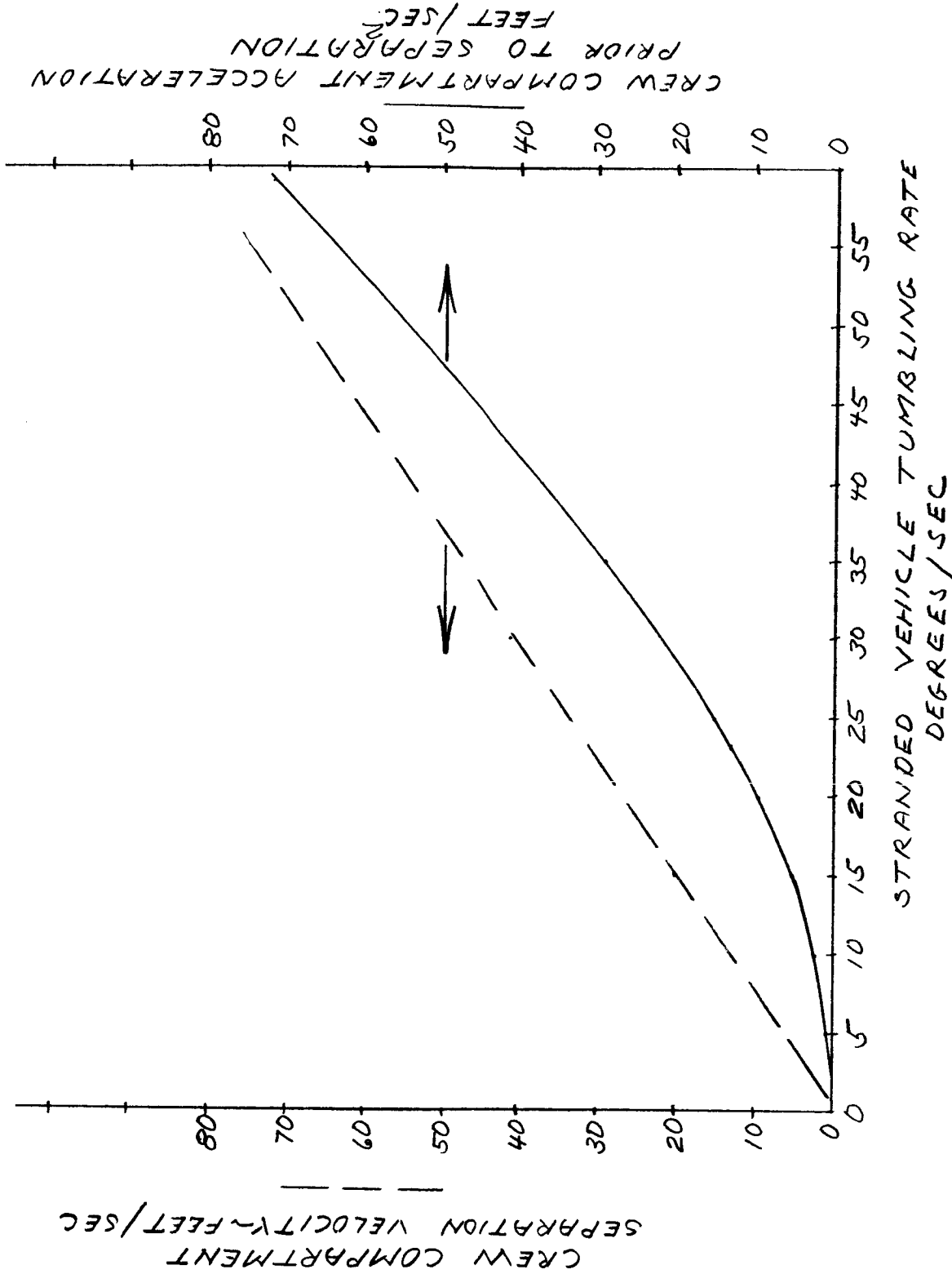

Fig. C-7 Tumbling Vehicle Crew Compartment Separation Data