

N 72-29081

Repro Copy:

1.0 INTRODUCTION

1.1 Introductory Comments

The National Aeronautics and Space Administration (NASA) has been a leader and innovator in the establishment, study, and assessment of technology transfer programs since that agency was established by the Space Act of 1958. Through its Tech Brief, Special Publication, Technology Survey, and Regional Dissemination Center programs, NASA has been successful in transferring the results of aerospace R&D to an impressive number of nonaerospace applications.

More recently NASA has established a program which uses an active and directed methodology. In this program, Application Teams have been established under contract to the NASA Technology Utilization Office. The Application Team methodology is active in that specific problems are identified and specified through direct contact with potential users of aerospace technology. The process is directed in that teams interact only with potential users who are involved in reaching selected national goals. Three teams concentrate in the biomedical area while others work in such fields as air pollution control, water pollution control, transportation, mine safety, and crime and law enforcement. The three teams specializing in biomedicine have been established at the following institutions:

Research Triangle Institute
Post Office Box 12194
Research Triangle Park, North Carolina 27709

Stanford University School of Medicine
701 Welch Road
Palo Alto, California 94304

Southwest Research Institute
8500 Culebra Road
San Antonio, Texas 78228

This report covers the accomplishments and activities of the Team located at the Research Triangle Institute for the period April 1, 1971, to December 31, 1971. In the remainder of Section 1.0, Team objectives and methodology are presented.

1.2 Application Team Program

The specific objectives of NASA's Application Team Program in biomedicine are as follows:

- (a) The transfer of a maximum number of specific items of aerospace technology to medicine in order to partially or fully solve problems in biology and medicine;
- (b) The transfer of aerospace technology to medicine in order to enhance the understanding of active processes of technology transfer; and
- (c) The motivation of potential adopters of aerospace technology in medicine, organizations involved in generating advanced technology, and individuals who can influence technology transfer programs to become actively involved in more comprehensive technology utilization programs.

A summary representation of the Application Team Program can be facilitated by referring to Figure 1. Basically, the Team represents an interface between medical investigators and clinicians and the body of scientific and technological knowledge that has resulted from the national aerospace R&D effort.

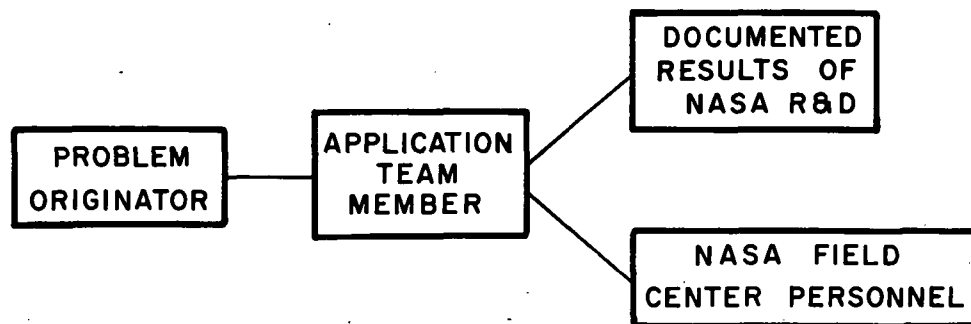

Figure 1. Possible mechanisms for transfer of technology.

The Team attempts to couple the technological problems and requirements in medicine with relevant aerospace technology and, in particular, NASA-generated technology. The problems and requirements are those being encountered in medical research programs attempting to improve general medical practice. The Team actively engages in identifying these problems through direct contact with medical staffs or problem originators. The identification and specification of medical problems is followed by a search for technology which may be relevant to solutions to these problems.

PREFACE

This report covers the medically related activities of the NASA Application Team Program at the Research Triangle Institute between April 1, 1971, and December 31, 1971. The activities were performed in accomplishing NASA Contract Nos. NASW-1950 and NASW-2273. This work was performed in the Center for Technology Applications of the Research Triangle Institute under the technical direction of Dr. J. N. Brown, Director. Full-time members of the Team who participated in the project are Dr. F. T. Wooten, Director of the Application Team; Mr. Ernest Harrison, Jr.; Mr. E. W. Page; and Mrs. Mary Carpenter. Assistance from other members of the RTI staff was obtained as needed.

Medical consultants who contributed significantly to the project are Dr. E. A. Johnson, Duke University Medical Center, Durham, North Carolina; Dr. George S. Malindzak, Jr., Bowman Gray School of Medicine, Wake Forest University, Winston-Salem, North Carolina; Mr. William Z. Penland, National Cancer Institute, Bethesda, Maryland; and Professor Hal C. Becker, Tulane University School of Medicine, New Orleans, Louisiana.

ABSTRACT

This report presents the results of the medically related activities of the NASA Application Team Program at the Research Triangle Institute. This experimental program in technology application was supported by NASA Contract Nos. NASW-1950 and NASW-2273 for the reporting period April 1, 1971, to December 31, 1971. The RTI Team is a multidisciplinary team of scientists and engineers acting as an information and technology interface between NASA and individuals, institutions, and agencies involved in biomedical research and clinical medicine. During the reporting period, participants in the Application Team Program included Dr. J. N. Brown, Jr., Electrical Engineer; Dr. F. T. Wooten, Electrical Engineer; Mr. Ernest Harrison, Materials Scientist; Mr. E. W. Page, Electrical Engineer; and Mrs. Mary Carpenter, Research Assistant. In addition, the Team draws upon the capabilities of other members of the RTI staff as needed.

Fourteen medical organizations are presently participating in the RTI Application Team Program: Bowman Gray School of Medicine, Wake Forest University, Winston-Salem, North Carolina; Duke University Medical Center, Durham, North Carolina; Emory University School of Medicine, Atlanta, Georgia; Institute of Rehabilitation Medicine, New York University, New York, New York; Medical University of South Carolina, Charleston, South Carolina; National Cancer Institute, Bethesda, Maryland; National Heart and Lung Institute, Bethesda, Maryland; National Institute of Environmental Health Sciences, Research Triangle Park, North Carolina; Ochsner Clinic and Foundation, New Orleans, Louisiana; Tulane University School of Medicine, New Orleans, Louisiana; University of Miami School of Medicine, Miami, Florida; University of North Carolina Dental School and Dental Research Center, Chapel Hill, North Carolina; University of North Carolina School of Medicine, Chapel Hill, North Carolina; and Virginia Department of Vocational Rehabilitation, Fishersville, Virginia.

The accomplishments of the Research Triangle Institute Application Team during the reporting period are as follows: The Team has identified 38 new problems for investigation, has accomplished 5 technology applications and 9 potential technology applications, has closed 50 old problems, has reactivated 2 old problems, and on December 31, 1971, has a total of 77 problems under active investigation.

LIST OF ABBREVIATIONS

| | |
|--------|---|
| AAMI | <i>Association for Advancement of Medical Instrumentation</i> |
| ARC | <i>Ames Research Center</i> |
| Team | <i>Application Team</i> |
| COSMIC | <i>Computer Software Management and Information Center</i> |
| FRC | <i>Flight Research Center</i> |
| GSFC | <i>Goddard Space Flight Center</i> |
| Hdqtrs | <i>NASA Headquarters</i> |
| IAA | <i>International Aerospace Abstracts</i> |
| KSC | <i>Kennedy Space Center</i> |
| LeRC | <i>Lewis Research Center</i> |
| LRC | <i>Langley Research Center</i> |
| MSC | <i>Manned Spacecraft Center</i> |
| MSFC | <i>Marshall Space Flight Center</i> |
| NCSTRC | <i>North Carolina Science and Technology Research Center</i> |
| RDC | <i>Regional Dissemination Center</i> |
| RTI | <i>Research Triangle Institute</i> |
| STAR | <i>Scientific and Technical Aerospace Reports</i> |
| TUO | <i>Technology Utilization Officer</i> |

TABLE OF CONTENTS

| | <i>Page</i> |
|---|-------------|
| 1.0 INTRODUCTION | 1 |
| 1.1 Introductory Comments | 1 |
| 1.2 Application Team Program | 2 |
| 1.3 Methodology | 3 |
| 1.4 Application Team Composition and Participating Medical Institutions | 6 |
| 1.5 Definition of Terms | 9 |
| 2.0 TECHNOLOGY APPLICATIONS, POTENTIAL TECHNOLOGY APPLICATIONS, AND IMPACTS | 13 |
| 2.1 Technology Applications | 13 |
| 2.2 Potential Technology Applications | 21 |
| 2.3 Impacts | 35 |
| 3.0 SUMMARY OF TEAM ACTIVITY DURING REPORTING PERIOD | 39 |
| 3.1 Problem Activity Summary | 39 |
| 3.2 Presentations by Team Members at Conferences, Meetings, and Symposia | 39 |
| 3.3 Visits to NASA Field Centers | 41 |
| 3.4 Association for Advancement of Medical Instrumentation (AAMI) | 41 |
| 4.0 SUMMARY OF APPLICATION TEAM STATUS AT USER INSTITUTIONS | 43 |
| 4.1 Introduction | 43 |
| 4.2 Summary Status for User Institutions Participating in the Program on December 31, 1971 | 43 |
| 5.0 APPLICATIONS ENGINEERING ACTIVITY | 45 |
| 6.0 CONCLUSIONS AND RECOMMENDATIONS | 53 |
| APPENDIXES | |
| A Project Activity Summary | A-1 |
| B Currently Active Problems | B-1 |
| C Application of Aerospace Technology to Medicine | C-1 |

1.0 INTRODUCTION

1.1 Introductory Comments

The National Aeronautics and Space Administration (NASA) has been a leader and innovator in the establishment, study, and assessment of technology transfer programs since that agency was established by the Space Act of 1958. Through its Tech Brief, Special Publication, Technology Survey, and Regional Dissemination Center programs, NASA has been successful in transferring the results of aerospace R&D to an impressive number of nonaerospace applications.

More recently NASA has established a program which uses an active and directed methodology. In this program, Application Teams have been established under contract to the NASA Technology Utilization Office. The Application Team methodology is active in that specific problems are identified and specified through direct contact with potential users of aerospace technology. The process is directed in that teams interact only with potential users who are involved in reaching selected national goals. Three teams concentrate in the biomedical area while others work in such fields as air pollution control, water pollution control, transportation, mine safety, and crime and law enforcement. The three teams specializing in biomedicine have been established at the following institutions:

Research Triangle Institute
Post Office Box 12194
Research Triangle Park, North Carolina 27709

Stanford University School of Medicine
701 Welch Road
Palo Alto, California 94304

Southwest Research Institute
8500 Culebra Road
San Antonio, Texas 78228

This report covers the accomplishments and activities of the Team located at the Research Triangle Institute for the period April 1, 1971, to December 31, 1971. In the remainder of Section 1.0, Team objectives and methodology are presented.

1.2 Application Team Program

The specific objectives of NASA's Application Team Program in biomedicine are as follows:

- (a) The transfer of a maximum number of specific items of aerospace technology to medicine in order to partially or fully solve problems in biology and medicine;
- (b) The transfer of aerospace technology to medicine in order to enhance the understanding of active processes of technology transfer; and
- (c) The motivation of potential adopters of aerospace technology in medicine, organizations involved in generating advanced technology, and individuals who can influence technology transfer programs to become actively involved in more comprehensive technology utilization programs.

A summary representation of the Application Team Program can be facilitated by referring to Figure 1. Basically, the Team represents an interface between medical investigators and clinicians and the body of scientific and technological knowledge that has resulted from the national aerospace R&D effort.

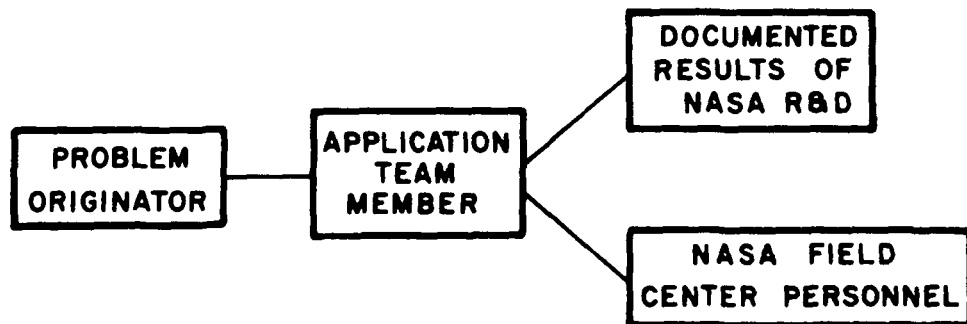

Figure 1. Possible mechanisms for transfer of technology.

The Team attempts to couple the technological problems and requirements in medicine with relevant aerospace technology and, in particular, NASA-generated technology. The problems and requirements are those being encountered in medical research programs attempting to improve general medical practice. The Team actively engages in identifying these problems through direct contact with medical staffs or problem originators. The identification and specification of medical problems is followed by a search for technology which may be relevant to solutions to these problems.

Generally, technology relevant to specific problems is identified through two approaches: (1) manual and computer searching of the aerospace information bank created by NASA as part of its R&D effort, and (2) direct contact with the engineering and scientific staff at NASA Field Centers. Technology representing potential solutions to problems is channeled through the Team to the problem originator for evaluation and implementation as a solution to his problem. Alternatively, and less frequently, the Team establishes a contact between the problem originator and NASA Field Center personnel, and the transfer of information between NASA and the medical field becomes more direct.

Assistance to the problem originator in implementing solutions to problems is an important part of the Application Team Program. This assistance may take any one of a number of different forms. Direct assistance to the problem originator in his efforts to implement a solution is frequently involved. During this reporting period, NASA's Technology Utilization Division has utilized reengineering or adaptive engineering facilities of various NASA centers in those cases where feasibility had to be demonstrated. The Teams are responsible for identifying the NASA technology which is potentially a solution to a specific problem and for specifying the changes required in this technology. This allows the Teams to demonstrate that the technology is in fact a solution to the problem and allows the problem originator to make use of the NASA technology in his work which might otherwise be impossible.

The successful transfer of information on aerospace technology to an individual or group in the medical field followed by successful implementation of the technology with resulting benefits to the accomplishment of some medical objective is called a "technology application." Also included in the definition of technology application is the constraint that the medical application and objective involved in the technology application be different from the aerospace application and objective for which the technology was originally developed. Thus, the accomplishment of technology applications is indeed a difficult and long-term objective. This objective should be distinguished from that involved in a program to enhance the diffusion or broad utilization of demonstrated applications of technology. Technology transfer involves crossing what may be thought of as an "application or objective barrier," and it involves complete evaluation of the new application; diffusion involves neither of these requirements.

A specific methodology is applied by the Team in its efforts to effect applications of aerospace related technology. This methodology is discussed in the following section.

1.3 Methodology

The methodology used by the Team consists of four basic steps: problem definition, identification of relevant technology, evaluation of relevant technology, and documentation. This methodology can be better

understood, however, if it is separated into the steps shown in Figure 2. These steps are described in the following paragraphs.

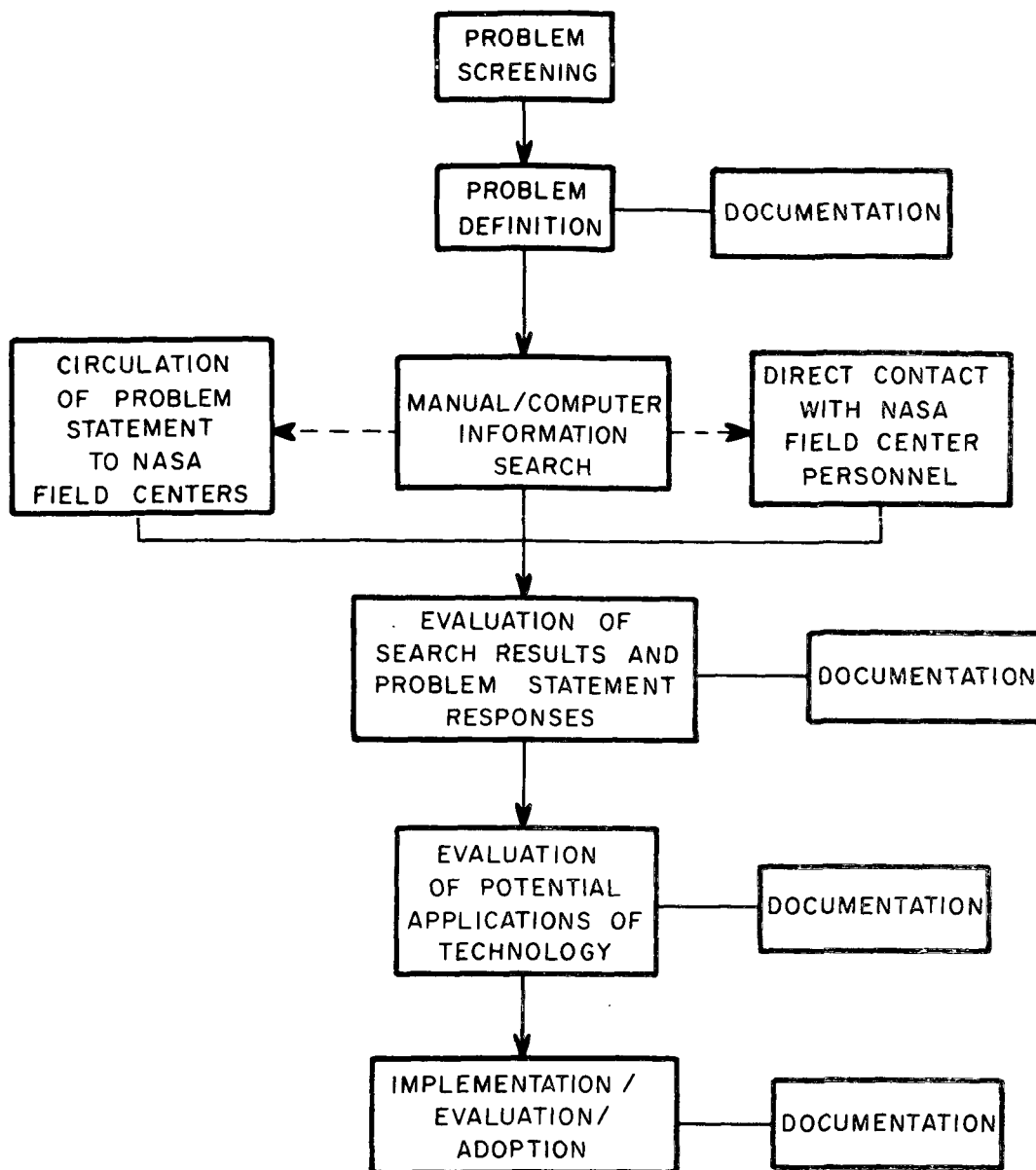

Figure 2. Flow chart of application team transfer methodology.

Problem Screening - Effective problem screening is at least as important to the success of the Application Team Program as any of the operational steps identified in Figure 2. Analysis of the RTI Team's accomplishments in the early days of the program indicates clearly that a very significant fraction of the problems which were investigated unsuccessfully could have been rejected very early in discussions with problem originators. Problem selection criteria have since been developed with the objective being to increase the probability that a technology application can be accomplished for those problems accepted by the Team. At the present the following criteria are being applied:

- (a) Solving the problem would enhance medical diagnosis, treatment, or patient care to the extent that implementation and adoption would be rapid.

OR

- (b) The problem has been encountered in an ongoing research program and is impeding progress of that program.

OR

- (c) Either some unique characteristics of the problem or the problem originator indicates that investigating the problem will enhance the overall Team program.

AND

- (d) Solving the problem is given high priority by the problem originator.

AND

- (e) The problem is one of *at most* two being investigated with an individual problem originator. (This is violated only in the case of mission-oriented group efforts.)

Problems which do not satisfy these criteria are rejected. Problems may also be rejected following partial completion of the next step, problem definition.

Problem Definition - The objective of this step is to define precisely and accurately the characteristics of the technology required to solve a problem. In many cases, following the characterization of required technology, it is found that the problem should be rejected or closed for any of a number of reasons. These reasons include, as examples, the following: (1) the problem can be solved using commercially available equipment; (2) the problem cannot be solved, so that an entirely different approach is indicated; (3) the real problem is medical and not technical in nature; and (4) the requirements cannot be specified because insufficient information exists on the objective involved.

The end result of problem definition is the preparation of a problem statement. This statement, to be complete, must contain (1) a complete characterization of what is required to solve the problem, and (2) the related medical problem or objective and the benefits to be realized by solving the problem.

Identification of Relevant Aerospace Technology - Aerospace technology which may be relevant to the solution of a problem is identified by three approaches. First, a manual or computer search is made of the aerospace information bank. These searches are made at one of NASA's six Regional Dissemination Centers (RDC). The RDC used by the RTI Team is the North Carolina Science and Technology Research Center (NCSTRC)

located in Research Triangle Park, North Carolina. The information which can be assessed through the RDC's bank consists of approximately 700,000 documents, articles, and translations which have been abstracted in the Scientific and Technical Aerospace Reports (STAR) and the International Aerospace Abstracts (IAA). Second, the Team contacts individuals at the Field Centers directly without circulating problem statements. This is done when a Team member can identify a relatively few individuals at the Field Centers who are likely to have a good overview of all work being done which is related to the requirements of a specific problem. Third, problem statements are circulated to engineers and scientists at NASA Field Centers who may be able to identify relevant technology and suggest possible solutions to problems. These statements are circulated in a highly selective manner with the distribution being determined by the Team, Technology Utilization Officers (TUO) at the NASA Field Centers, and other individuals at the Field Centers.

Evaluation - All potentially relevant technology identified in the preceding step is evaluated by the Team to determine whether a potential solution to a specific problem has been found. Those items of technology which represent potential solutions to problems are presented to problem originators along with available supporting data and information. Any required reengineering and details of implementing the potential solutions are discussed with the problem originator.

The problem originator must then evaluate potential solutions. His decision to implement a proposed solution will depend upon a number of factors: (1) his assessment of the validity of the proposed potential solution, (2) the cost of implementing the potential solution, (3) the potential benefits to be gained, etc. The Team may be asked to supply additional information and technical details in this evaluation.

Implementation, Final Evaluation, Adoption - The final step in the technology application process is the implementation and experimental evaluation of potential solutions. The Team is available for assistance in this step when required. Hopefully, when a potential solution is shown to be a valid solution to a problem, this solution is adopted and implemented by the problem originator which completes the transfer.

Documentation - Documentation is an integral part of the Team methodology; it is involved at most steps in the process, as indicated in Figure 2. Documentation allows analysis of the technology application process and assessment of the program in general. At present, the Teams report on a weekly, monthly, and semiannual schedule. Effective communication is required between Teams, potential problem originators, and other individuals who are in a position to make use of information resulting from technology applications accomplished by the Teams.

1.4 Application Team Composition and Participating Medical Institutions

The RTI Team is a multidisciplinary group of engineers and scientists. The educational backgrounds of the group are in physics and electrical engineering; their experience includes industry, education,

and research at both basic and applied levels. The individuals who have participated in the Application Team Program during this reporting period are:

| <i>Name</i> | <i>Background</i> | <i>Responsibility</i> |
|----------------------|---------------------|-----------------------|
| Dr. J. N. Brown, Jr. | Electrical Engineer | Laboratory Supervisor |
| Dr. F. T. Wooten | Electrical Engineer | Team Director |
| Mr. E. Harrison, Jr. | Materials Scientist | Solution Specialist |
| Mr. E. W. Page | Electrical Engineer | Solution Specialist |
| Mrs. Mary Carpenter | Research Assistant | Documentation |

The experience and special capabilities of other individuals at RTI--particularly in the Engineering and Environmental Sciences Division--are frequently used as needed in the Application Team Program.

At present, 14 medical institutions are participating in the RTI Application Team Program. These institutions are as follows:

Bowman Gray School of Medicine, Wake Forest University,
Winston-Salem, North Carolina;

Duke University Medical Center, Durham, North Carolina;
(Including Veterans Administration Hospital, Durham, North Carolina);

Emory University School of Medicine, Atlanta, Georgia;

Institute of Rehabilitation Medicine, New York University, New York,
New York;

Medical University of South Carolina, Charleston, South Carolina;

National Cancer Institute, Bethesda, Maryland;

National Heart and Lung Institute, Bethesda, Maryland;

National Institute of Environmental Health Sciences, Research
Triangle Park, North Carolina;

Ochsner Clinic and Foundation, New Orleans, Louisiana;

Tulane University School of Medicine, New Orleans, Louisiana;

University of Miami School of Medicine, Miami, Florida;
(Including Veterans Administration Hospital, Miami, Florida);

University of North Carolina Dental School and Dental Research
Center, Chapel Hill, North Carolina;

University of North Carolina School of Medicine, Chapel Hill,
North Carolina;

Virginia Department of Vocational Rehabilitation, Fishersville,
Virginia.

Figure 3 shows the geographical distribution of the RTI Application Team user institutions as well as the location of the major NASA resources.

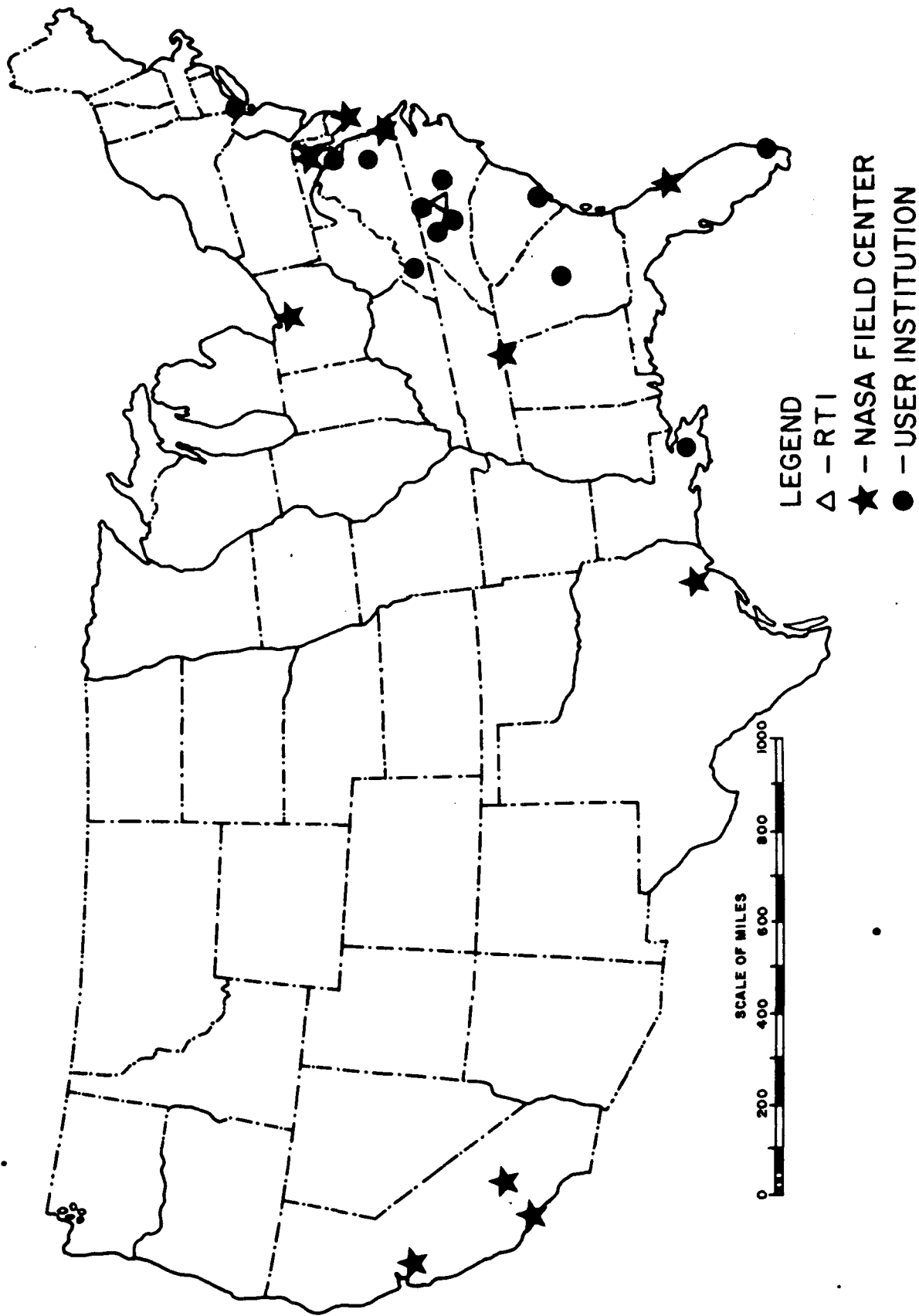

Figure 3. Team activity centers in the United States

The RTI Team is assisted at various stages of the technology application process by consultants who are on the medical staff at participating institutions. These consultants or communicators coordinate Team activities at their institutions and assist Team members primarily in problem definition and evaluation of potential solutions. At present, the following individuals are consultants to the RTI Team:

| <i>Name</i> | <i>Specialty</i> |
|---|--------------------|
| Dr. E. A. Johnson Duke University Medical Center | Cardiac Physiology |
| Dr. George S. Malindzak, Jr. Bowman Gray School of Medicine, Wake Forest University | Physiology |
| Professor Hal C. Becker Tulane University School of Medicine | Radiology |
| Mr. William Z. Penland National Cancer Institute | Engineering |

Problems at each institution are coded by a letter and number symbol (e.g., DU-49); the coding for each institution or special problem area is as follows:

- CP - Computer software-type problem
- DU - Duke University Medical Center
- EU - Emory University School of Medicine
- IRM - Institute of Rehabilitation Medicine, New York University
- MISC - Miscellaneous
- MUSC - Medical University of South Carolina
- NCI - National Cancer Institute
- NEHSC - National Institute of Environmental Health Sciences
- NHLI - National Heart and Lung Institute
- NIMH - National Institute of Mental Health
- OF - Ochsner Clinic and Foundation
- TU - Tulane University School of Medicine
- UNC - University of North Carolina School of Medicine
- UNCD - University of North Carolina Dental School and Dental
Research Center
- VAM - University of Miami School of Medicine
- WF - Bowman Gray School of Medicine, Wake Forest University

1.5 Definition of Terms

In the Application Team Program, a number of terms have evolved which describe the elements and processes in this program. Because of their number and unfamiliarity to many readers, these terms are listed and defined in this section for easy and quick reference.

Problem Originator or Researcher - An individual actively involved in an effort to reach a specific objective in biology or medicine and faced with a specific technological problem which is impeding progress toward that objective.

Participating Institution - A medically oriented educational institution, hospital, medical center, or government agency having as one of its organizational objectives the improvement of medical health care.

Consultant - A member of the biomedical staff at a participating user institution who has committed a portion of his time and effort to assist the Team in identifying and coordinating visits with appropriate problem originators at his institution, in understanding and specifying problems in biology and medicine, and in evaluating technological solutions to problems.

Application Team (Team) - A multidisciplinary group of engineers and scientists engaged in problem-solving activities in biology and medicine with the specific objectives of effecting the transfer of aerospace technology to solve or aid in solving problems in medicine and of understanding and optimizing the methodology for effecting such transfers of technology. The methodology used by the Team involves (1) problem selection, definition, and specification; (2) identification of potential solutions to problems by manual and computer information searching, circulation of problem statements to NASA Field Centers, and contacts with NASA engineers and scientists; (3) evaluation of potential solutions; (4) implementation and adoption by problem originators of aerospace technology as solutions or partial solutions to medical problems; and (5) documentation.

Problem - A specific and definable technological requirement that cannot be satisfied with commercially available equipment or through the application of information or knowledge available to the problem originator through routinely used information channels.

Technology Application - This is the implementation and adoption of aerospace technology which solves a problem in biology or medicine. The medical application involved is one which is different from that application for which the aerospace technology was originally developed.

Problem Statement - This is a concise, written statement of a problem which is used for communicating (1) sufficient details to allow a computer search to be performed by the information search specialists, and (2) sufficient information to enable NASA engineers and scientist to consider possible solutions to the problem.

Computer Information Search - This is a computerized information search of the aerospace information bank established by NASA and made available through six Regional Dissemination Centers in the United States. This information bank consists of the approximately 700,000 documents which have been indexed and abstracted in the Scientific and Technical Aerospace Reports (STAR) and International Aerospace Abstracts (IAA).

Impact - Information is given to a problem originator with the result that he changes his activities in a way that enhances his progress toward a medical objective. An impact is thus analogous to a technology application except that one or more of the requirements for a technology application are not satisfied.

2.0 TECHNOLOGY APPLICATIONS, POTENTIAL TECHNOLOGY APPLICATIONS, AND IMPACTS

2.1 Technology Applications

During the reporting period, five applications of aerospace technology were accomplished and are discussed in the following summaries:

PROBLEM EU-4 *A Simple Method of Obtaining Electrical Connection to 25-Micron Wire*

A NASA development in electrocardiographic electrodes has been modified to solve a problem in measuring electromyographic (EMG) signals which are frequently measured in rehabilitation mediums.

In EMG studies of the spinal musculature, fine wire (25-micron) subcutaneous electrodes are hypodermically injected into the muscle whose EMG signal it is desired to monitor. The end of the electrode wire not in the muscle protrudes through the skin approximately 1 to 1-1/2 inch. The external end of the electrode wire must be electrically connected to the input of an integrated circuit preamplifier strapped or taped nearby. Soldering, welding, or other bonding techniques which pose a real or psychological danger to the patient cannot be employed. The technique in use when this problem was defined employs a coil spring which is attached to the input terminal of the preamplifier as the connector. Connection is made by pulling the spring apart, inserting the bare electrode wire, and allowing the spring to compress back down on the wire. Although handy and easy to use, electrical connection is essentially accomplished by means of "smeared" point contacts with this method so that reliable contact is not always achieved or maintained. Significant and time-consuming difficulties have been frequently experienced using this technique. A better method of connecting the electrode lead to the preamplifier is desired. The connection technique must be easy to use with this fine wire, must provide reliable and low impedance connection, and must not be hazardous or threatening to the patient.

The Team suggested a connection technique employing a conductive adhesive based on the NASA-developed dry electrode techniques as a potential solution to this problem. This technique is described below. The terminals to the preamplifier are constructed by forming two tabs or "lands" of copper separated by a small distance on a chip of printed circuit board (see Figure 4).

These terminals are attached to the preamplifier, and connection from the preamplifier to the terminals is accomplished by soldering. Because of the small size of the electrode wire and resulting difficulty in handling, it is necessary to fix the wire in place before the electrical connection can be made. To accomplish this, a small double-backed adhesive template shaped as shown in the illustration is applied to each terminal tab. Next, the electrode wire to be

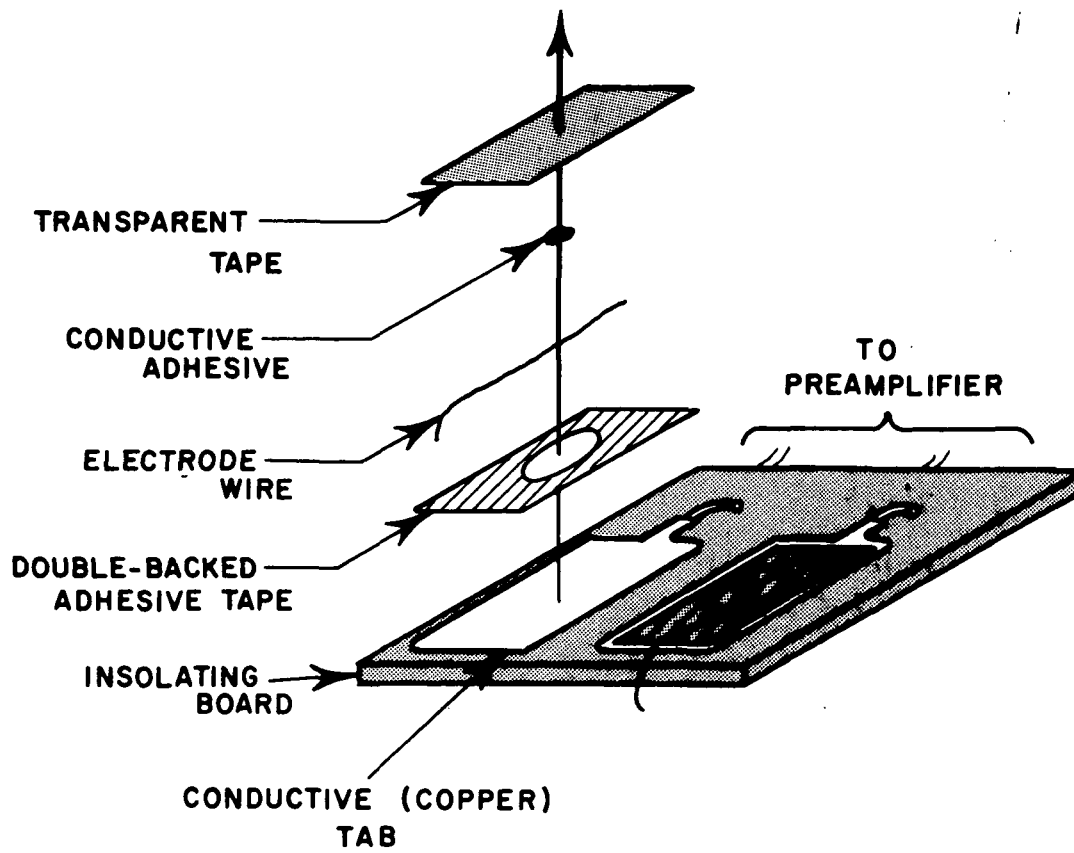

Figure 4. Connection technique for EMG electrodes.

attached is stretched across the tab and pressed into the adhesive at each end of the tab. This holds the wire in a fixed position so that the conductive cement can be easily applied. The conductive adhesive is applied using a camel's hair brush, a Q-Tip, or other convenient applicator. Using a small hand-held blower of the hair dryer type, the cement can be dried in less than 15 seconds. Then, to obtain additional mechanical strength, a piece of transparent adhesive tape is applied over the terminal. This technique has provided excellent electrical connection between the preamplifier and the electrode wires and has been very reliable. In addition, because of its ease of attachment, technicians have quickly learned the technique and become proficient in its application. Tests have been conducted clinically with human subjects and also in a research program in which gorillas were used as test animals. In both cases, this connection technique was highly successful. The researcher considers the connection problem completely solved and is using this technique routinely as a part of his standard procedures.

PROBLEM NCI-8 *Elliptical Lens*

An optical design computer program developed by NASA has been used to design an unusual lens necessary for basic cancer research.

In many advanced medical research studies (e.g., cancer studies), the basic unit of study is the human cell. As medical science has demanded more information on cellular activities, technology has frequently played a critical role in extracting the information from regions within each cell.

An excellent example of this fact is a study being conducted by the National Cancer Institute (NCI) in which an optical microscope is controlled by a digital computer in order to get quantitative microspectrophotometric histochemical data. This study could not be conducted otherwise because of the limitations on the human eye as a colorimeter. In addition, this same system can be used to obtain three-dimensional microarchitecture of human tissue.

Although this study has been underway for some time, a difficulty has been encountered in obtaining sufficient light intensity from the monochrometer which is focused on the specimen. The light source has been increased in intensity to the maximum possible.

One possible solution is to use an elliptical lens between the monochrometer and the specimen which will make more effective use of the available light.

This improvement in efficiency results because an elliptical lens converts the rectangular beam of light from the monochrometer to a more circular shape and thus more of the monochrometer output is focused on the sample. The researchers have been unable to locate a commercial source for the desired lens. The National Bureau of Standards Optical Shop has indicated a willingness to grind the lens if procedures for grinding elliptical lenses can be obtained.

Two circular 60 millimeter diameter lenses are required. One lens has a focal length in the X direction of 150 millimeters and focal length in the Y direction of 40 millimeters. The second lens has a focal length in the X direction of minus 500 millimeters and a focal length in the Y direction of 50 millimeters. The wavelength of light used varies from 220 to 700 nanometers.

A direct contact was made with Juan Pizzaro at Marshall Space Flight Center who suggested a NASA-developed computer program which is used for designing complex optical systems. This program has not been used for elliptical lenses, but NASA personnel believed that the program would perform the desired design. The Fortran language program documentation and tapes were obtained from COSMIC and shipped to the researcher. The program, resulting from a study funded by the Jet Propulsion Laboratory, was capable of designing optical systems containing up to 100 planes, conic or aspheric surfaces, seven object points, six colors, and 200 rays. The program was written in Fortran IV for use on the IBM 7094 computer.

The NCI researcher used the program in order to design the desired lenses. The National Bureau of Standards Optical Shop will grind the lenses.

The availability of the lenses will improve the ability of the NCI research team to extract detailed histochemical data from human cells. This will be used in a system for automatic microspectrophotometric analysis of biological specimens.

PROBLEM NHLI-5 *Bonding of Metal to Ceramic*

A bonding technique developed by NASA for use in rocket nose cones has been used to solve a bonding problem in an artificial heart being developed under a National Institute of Health (NIH) contract.

In attempting to achieve an artificial heart system for man, the guiding objective is not only to prolong life per se but also to provide full rehabilitation to the patient. To the extent that this goal can be realized, the patient should experience a minimum of discomfort and encumbrance. Ideally, the prosthetic heart system should be totally implantable, i.e., all its parts should be contained within the body. In addition to the many physical and physiological requirements that must be met to realize a compatible, safe, and reliable system for long-term use, the artificial heart must also satisfy many stringent design and functional requirements typically demanded of high performance aerospace systems.

A variety of systems have been suggested for supplying electrical energy to an implantable artificial heart. An unanswered problem is that of the type of electrical-to-mechanical energy conversion system which will be used to carry out the pumping function of the heart. A piezoelectric system in which a column of ceramic disks is excited axially by electrodes interspaced between the disks is one of the candidates for this task. Such a device is illustrated below in Figure 5.

The ceramic disks are constructed so that they will exhibit piezoelectric properties, i.e., when subjected to electrical excitation they become mechanically deformed. Thus, upon the application of an electric field across the stack, each disk lengthens axially and the net result is an additive linear movement in the axial direction of the stack. An alternating current excitation, therefore, results in successive expansions and contractions of the column. It is this mechanical energy that will power the blood pump.

Because of the importance of the physiological function performed by the energy conversion system, design configurations and techniques take on increased significance. In seeking to provide the desired longevity and high reliability of the energy conversion system, the technique of bonding the interspaced electrodes to the ceramic disks becomes an important consideration. In addition to the requirement for a mechanically strong bond, the bonding technique should neither contribute to the electrical breakdown of the ceramic disk nor decrease the conversion efficiency of the device.

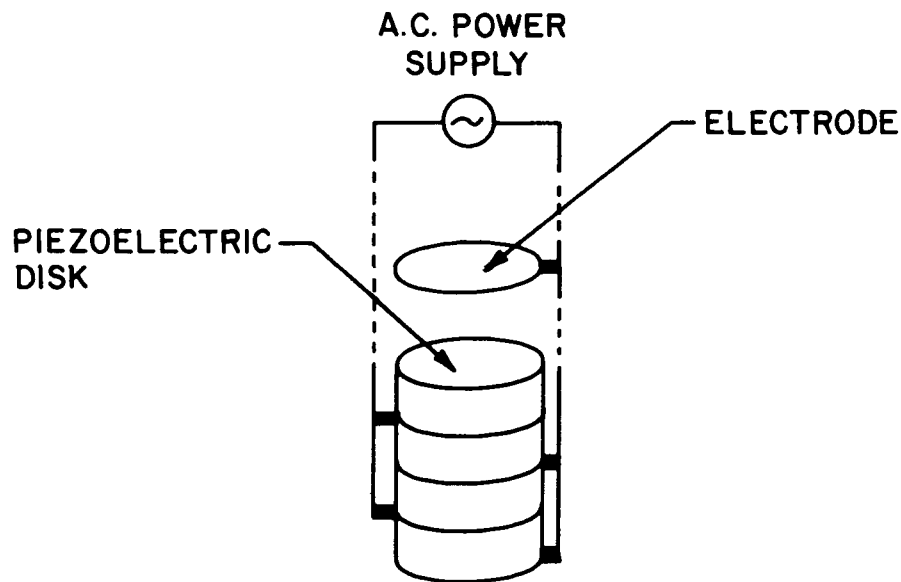

Figure 5. Piezoelectric stack bonding.

The Technology Utilization Office at Langley Research Center was informed of this problem, and Mr. John Samos was successful in locating an engineer, Mr. Ray Lovelady, who had constructed several piezoelectric stacks for preliminary investigations. The piezoelectric systems constructed by NASA were intended for use as ultrasound transducers to provide an acoustic signal to aid in locating rocket nose cones and other payloads which are submerged in water following reentry.

Of the variety of bonding techniques which had been explored by the Sensor Development Section at Langley, two techniques had emerged as being the best suited for the application in question: one employing epoxy and the other making use of mechanical loading. Epoxy bonding has been used at Langley in such devices as strain gauges and sound pressure sensors.

The NIH contractor was advised of the NASA development and tested the technique in the artificial heart. The bonding technique proved successful and was incorporated by the NIH contractor.

PROBLEM WF-103 *Liquid Crystal Sterilization*

The kidney is supplied with blood by the renal artery which consists of at least two major branches, a large anterior and a smaller posterior. The former supplies the anterior part of the kidney exclusively, and the latter supplies the posterior part exclusively. Consequently, there exists a line, called Broedel's line, which passes between the two main arterial divisions in which there are no large blood vessels. When it is necessary to open the kidney surgically, it is desirable to make the incision along this line for obvious reasons. It is difficult to locate the boundary line between the various regions visually, however. The researcher raised the question of the applicability of liquid crystals to determine these boundaries. Samples of encapsulated liquid crystals were obtained by the researcher from a commercial supplier and from Marshall Space Flight Center (MSFC). Tests were made on dogs, and the researcher reported that the liquid crystal films were very effective in establishing these boundaries. It is now necessary to establish methods for sterilization of the liquid crystal films before they can be used in regular procedures. The Team has been requested to assist the researcher in determining a suitable sterilant for the liquid crystal films which will not impair their effectiveness.

The Team contacted MSFC with respect to this problem since MSFC has been active in using liquid crystals for nondestructive testing purposes. The medical researcher was placed in contact with personnel at MSFC, and the overall problem was discussed. The encapsulated liquid crystals developed for MSFC's use under NASA contract were considered to be an ideal solution to this particular problem. Mr. Juan Pizzaro of the Technology Utilization Office at MSFC obtained a variety of liquid crystal materials in encapsulated form. Also, personnel at Marshall who had experience in working with liquid crystals were consulted concerning the best means of sterilizing the encapsulated liquid crystals. Gas sterilization was suggested by the researchers at Marshall. Evaluation proved this to be the best solution to the sterilization problem. The liquid crystal material obtained from Marshall Space Flight Center was used by the researcher in several animal experiments to perform surgery on the kidney of dogs. The results of these tests indicated that the technique was very effective. The tests were performed in the following manner. The kidney of the dog was surgically exposed and then one of the arteries leading to the kidney was ligated. Then the kidney was placed in a cooling bath. Upon removal from the cooling bath, the artery not ligated furnished blood to the kidney, heating that portion of the kidney. The researcher was then able, using small strips of liquid crystals, to trace out the line of demarkation between the two arterial supplies. (See Figure 6). The juncture between the light and dark areas of the liquid crystal strips indicates the location of Broedel's line. This permitted incision into the kidney to be made without severing any major arteries.

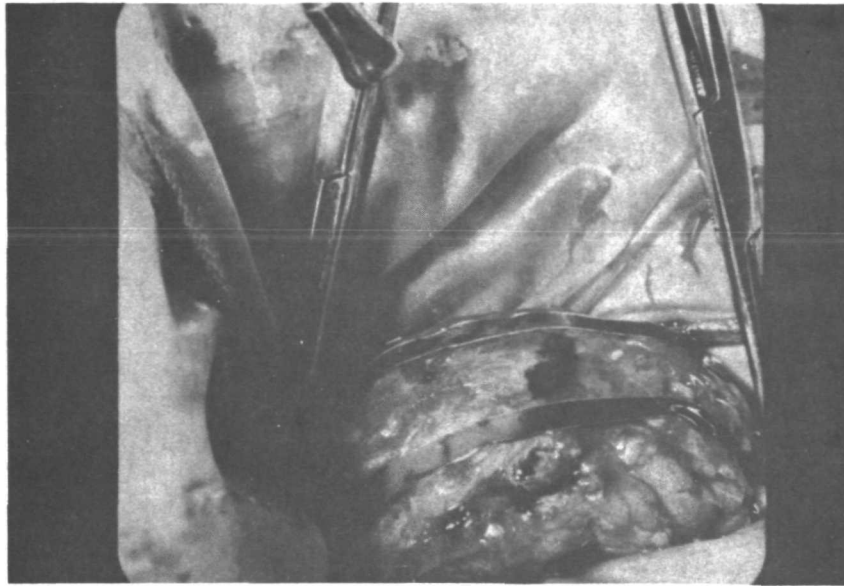

Figure 6. Liquid crystal on canine kidney.

The advice on sterilization and the encapsulated liquid crystals supplied by the Marshall Space Flight Center was vital in the accomplishment of this transfer. The researcher is currently discussing, with a commercial supplier, the possibility of obtaining prepackaged sterile liquid crystal strips for general use in this surgical application.

PROBLEM WWRC-14 *An Improved Axillary Strap*

A material developed for use in spacecraft cushions has been used to improve a widely used arm prosthesis.

Commonly used upper extremity prostheses employ a cabling arrangement to operate the hook which achieves pinch, thus permitting items to be grasped and transported. In operation, the cable is passed across the back of the patient, then around the arm near the shoulder joint so that, by flexing the shoulder muscles, the cable can be pulled causing the hook to close. Usually, a saddle-type arrangement to which the cable is attached is used around the arm at the shoulder. It is not infrequently constructed of canvas to which padding has been added. Unfortunately, when the wearer of the prosthesis flexes his shoulders to achieve pinch on the prosthetic hand, the saddle tends to roll up or curl up until it actually resembles a rope, causing concentration of all of the force being exerted by the shoulder and arm on a very small area. This frequently results in tender spots caused by the excess pressure being exerted and reduces the effectiveness of the patient in operating his prosthesis. Basically, a means of distributing the force exerted on the axillary strap over a larger surface area is desired in order to reduce the force per square unit of area on the arm and shoulder. In order to be economically feasible, the strap must essentially be a universal device which can be applied to any patient requiring an upper extremity prosthesis. This means

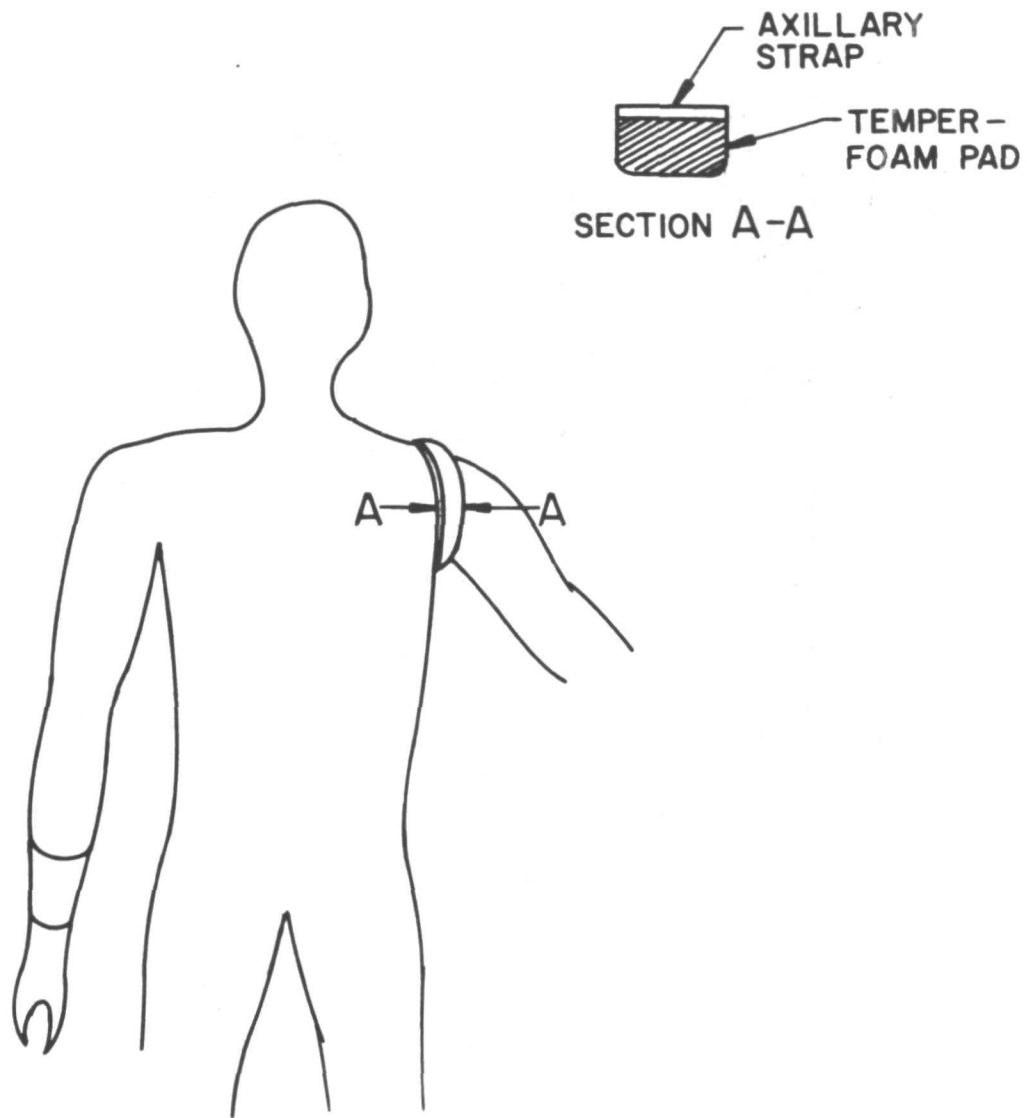

Figure 7. Axillary Strap Pad

that individually fitted straps that might be contoured to the patient's arm or shoulder would not be acceptable. This strap must be capable of being used by a large number of people.

The NASA-developed polymethane foam material proposed by Ames Research Center was felt to offer the possibility of solving this particular problem. (See Figure 7). The foam is a special material which has some unique characteristics. It absorbs energy which would make it attractive in this application because cushioning and spreading of the force exerted by the shoulder is considered to be the primary means whereby this problem can be solved. The material will mold to the form of the body with which it is in contact. Because of the thermal characteristics of the material, it is sensitive to temperature and pressure which both affect its elastic properties. This thermoviscous material, when used in a shoulder strap such as this, would conform to the body and with the application of pressure would deform to yield uniform pressure across the pad rather than concentrating the pressure which is the source of the problem. A sample of the material was obtained for the medical researcher who then initiated an evaluation program. Evaluation has proved that this material is better than anything previously tested in preventing soreness caused by the axillary strap.

2.2 Potential Technology Applications

During the reporting period, eight problems achieved the status of potential technology applications. This status indicates that an adequate solution to the problem has been identified and implementation is in various stages of accomplishment. These eight problems are discussed in the following summaries.

PROBLEM EU-5 *Sensors to Define the Position of Specific Parts of the Human Anatomy in Space During Normal Locomotion*

A suit developed for NASA may prove to be a key factor in the diagnosis of various disorders of locomotion.

Many studies involving gait, locomotion, spinal damage, etc. require time-spatial measurement of various bones with respect to each other or some external reference. These studies are important for the diagnosis of gait abnormalities and for the evaluation of the effectiveness of therapeutic procedures and prosthetic attachments in improving treatment of disabilities associated with locomotion. In the past, photographic and TV techniques against one or more reference grids have been employed to obtain this information in a more or less fragmentary and hard to measure fashion. These techniques require that the measurements be taken in a laboratory or other prescribed environment in order to maintain proximity to the optical recording apparatus and the reference grids. It is desired to obtain a method of measuring the position of bones of the legs and hips with respect either to an external reference point or to a movable reference point on the body. For preliminary applications the

attachment of mobility limiting devices such as cables will be permitted to prove feasibility of the measurement techniques. The eventual goal of these studies, however, is to obtain such measurements when the subject is free-ranging in his normal environment. This will require telemetric transmission of these data to a remote point. Essentially, sensors which can provide quantitative data on their positions with respect to each other or some external reference are desired.

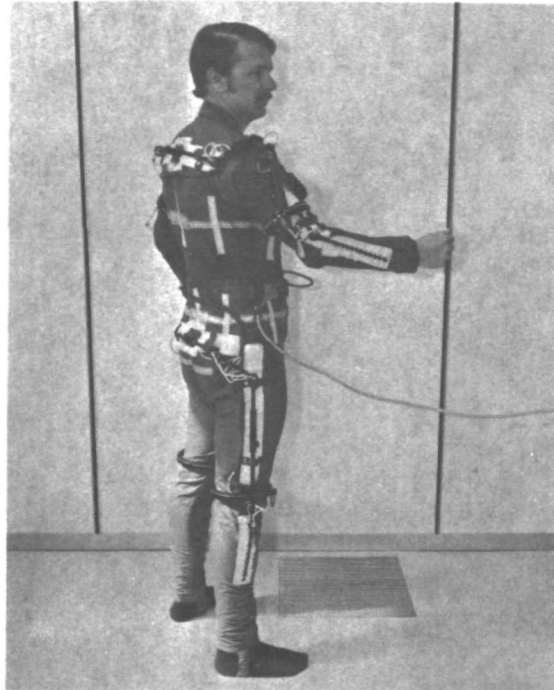

Figure 8. NASA exoskeleton suit.

The potential solution to this problem was discovered as a result of personal communications with personnel at the Langley Research Center. (See Figure 8). A specially instrumented suit for the Crew Vehicle Disturbances Study in the 1973 Skylab Mission was developed at the Langley Research Center. The suit essentially consists of a partial exoskeleton which is fitted to the individual by means of a suit. Potentiometers are used at the various joints and also on rings located on the arms and legs to provide information on the angular relationships between the joints. The rings on the arms and legs provide information on rotation of the arms and legs. This unit is lightweight and compatible with the overall requirements of the problem. The results at LRC indicate that precision of measurement of rotation of one member with respect to the other using this technique approaches plus or minus one percent. It is anticipated that some difficulty may be encountered in affixing the exoskeleton to the patient. However, this difficulty may be overcome by the light weight and relatively small size of the exoskeleton. For these preliminary studies it is anticipated that only the lower half of the exoskeleton unit will be required since the studies are primarily concerned with gait analysis. The present suit developed at LRC uses an umbilical cable to transmit data from the potentiometers on the exoskeleton to the data processing equipment. A study has been made of the

requirements involved in instrumenting a telemetric system and the design of the telemetry apparatus has been completed. If evaluation of the exoskeleton proves that this approach will provide the necessary data for the analysis of gait abnormalities and the other aspects of the planned locomotion studies, then it is expected that telemetric techniques will be required to obtain the greatest utility and versatility in the use of this technique.

PROBLEM EU-12 *A Rapid Method of Applying EEG Electrodes*

A special helmet developed by NASA may prove useful in measuring neurological disorders.

People with neurologic dysfunction represent a significant portion of the patients undergoing rehabilitation in the United States. Neurologic dysfunction can occur as a result of birth defects, disease, or traumatic injury. Emory University Regional Rehabilitation Research and Training Center is active in the rehabilitation of such patients. One of the first things to be determined about such a person is the degree of neurologic dysfunction. One program objective at Emory University Regional Rehabilitation Research and Training Center is to develop techniques to measure the degree of neurologic dysfunction. This information is required at the beginning of treatment because, if the patient cannot process sensory information, there is little hope for rehabilitation.

At the present time, evoked responses as measured by electroencephalograms (EEG) are used as an index of dysfunction. In this technique, stimuli of various kinds (auditory, visual, tactile, etc.) are presented to the patient, and the EEG is recorded from electrodes attached to the patient's skull at points appropriate to the type of stimulus. Multiple electrodes are required, varying from three to 16, depending on various circumstances. Attachment of these electrodes by conventional techniques (e.g., collodion) is very time-consuming and frustrating to the patient. It can also be downright alarming to the patient, particularly to those who have received shock therapy.

Severely mentally retarded children present a particular problem. It is desired to employ these techniques to determine neurologic dysfunction in severely mentally retarded children, but conventional EEG techniques are impossible with these children. They present very significant problems in handling. They are very difficult to engage in any long-term activity; e.g., it is virtually impossible to persuade such a child to remain seated for the 10 or 15 minutes required to attach the EEG electrodes. In addition, hostile reactions are not infrequent in which the child will reach up and rip an electrode off while another is being applied. As a result, a simpler means of obtaining EEG data is required--specifically, a technique which will permit the installation of electrodes in a very rapid fashion.

An EEG helmet developed by NASA in the astronaut program was identified as potentially useful in this application. One of the EEG helmets, a three-electrode design, was borrowed from the NASA biomedical applications team at SwRI, which has been modifying the helmet design for civilian biomedical applications. The researcher tested the helmet at Emory University Regional Rehabilitation Research and Training Center using the following procedure.

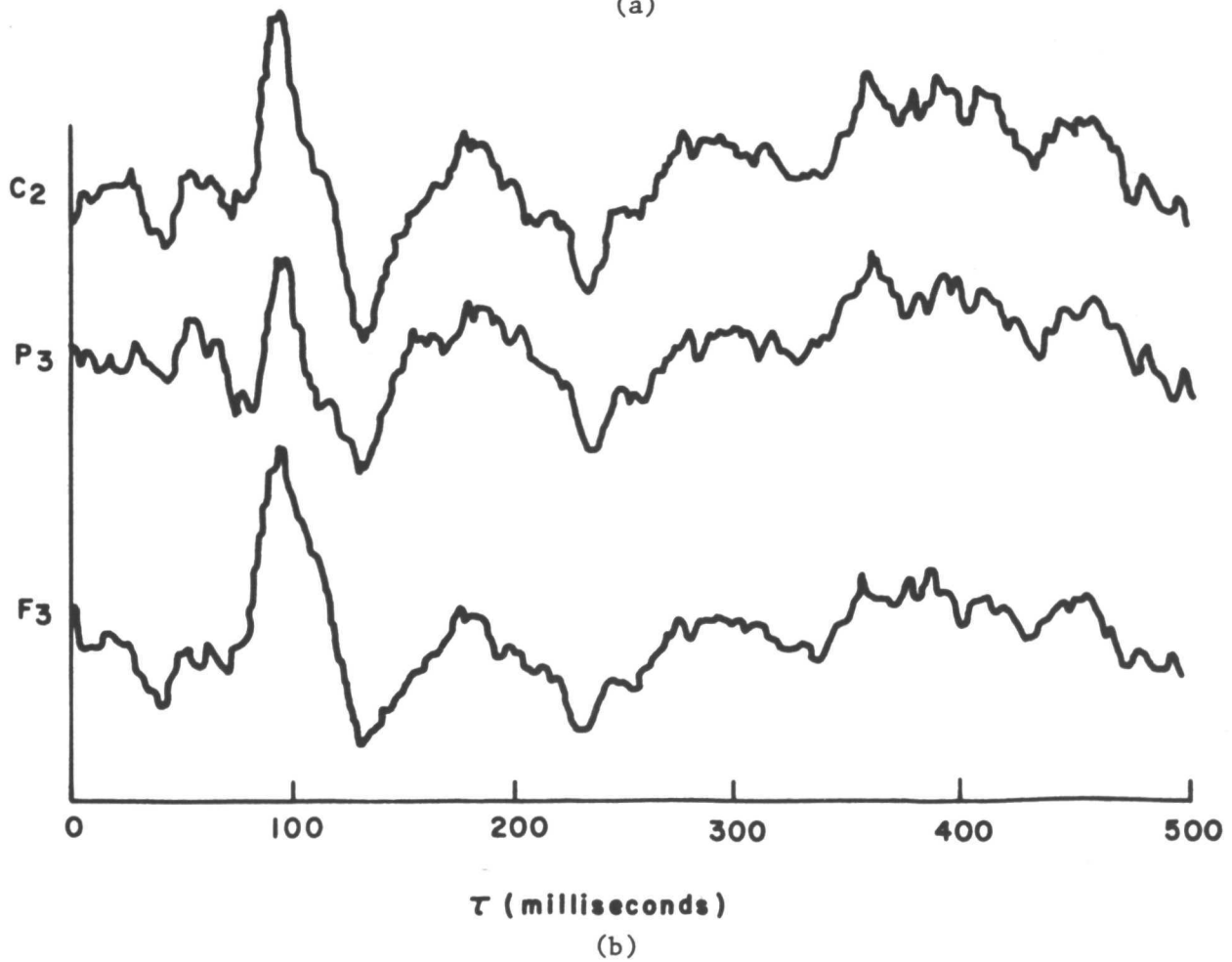
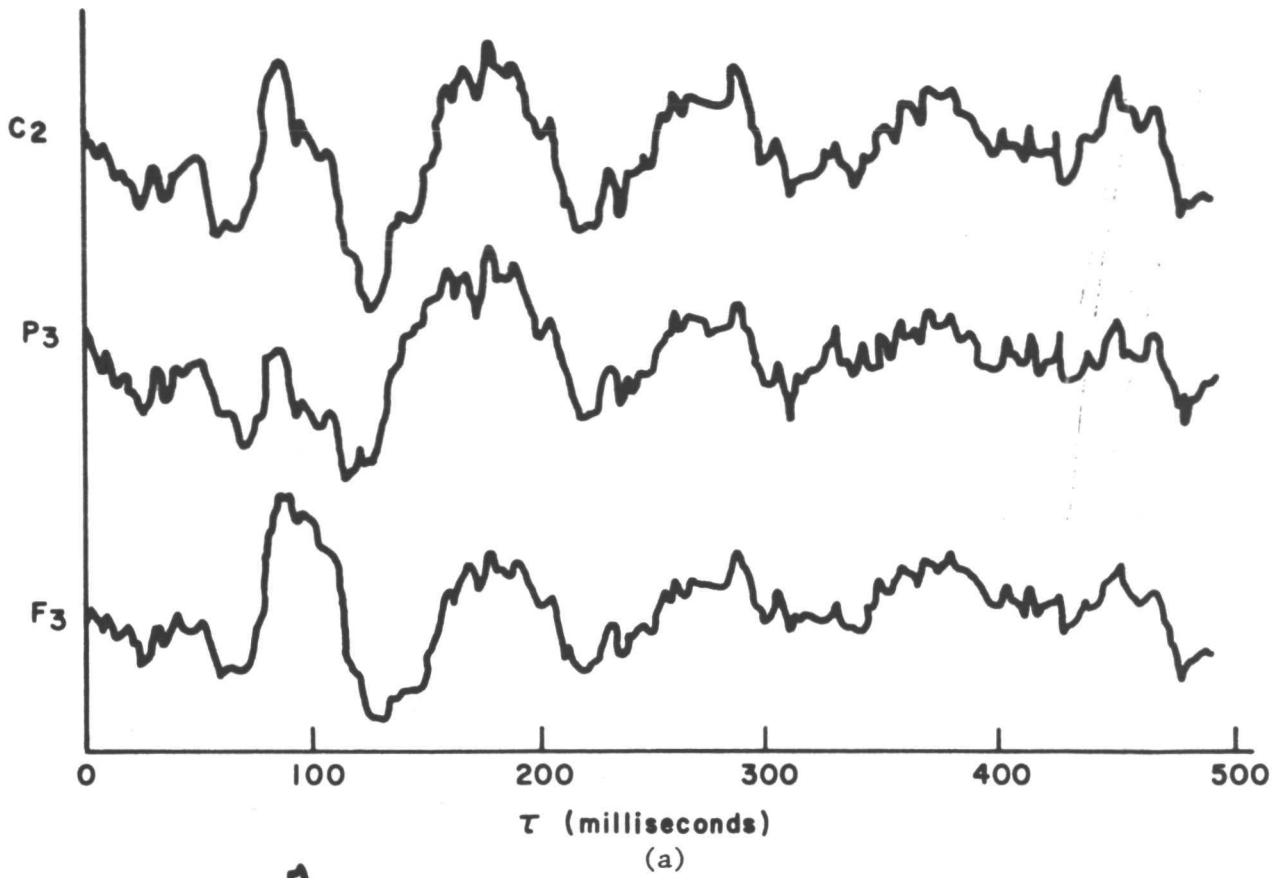
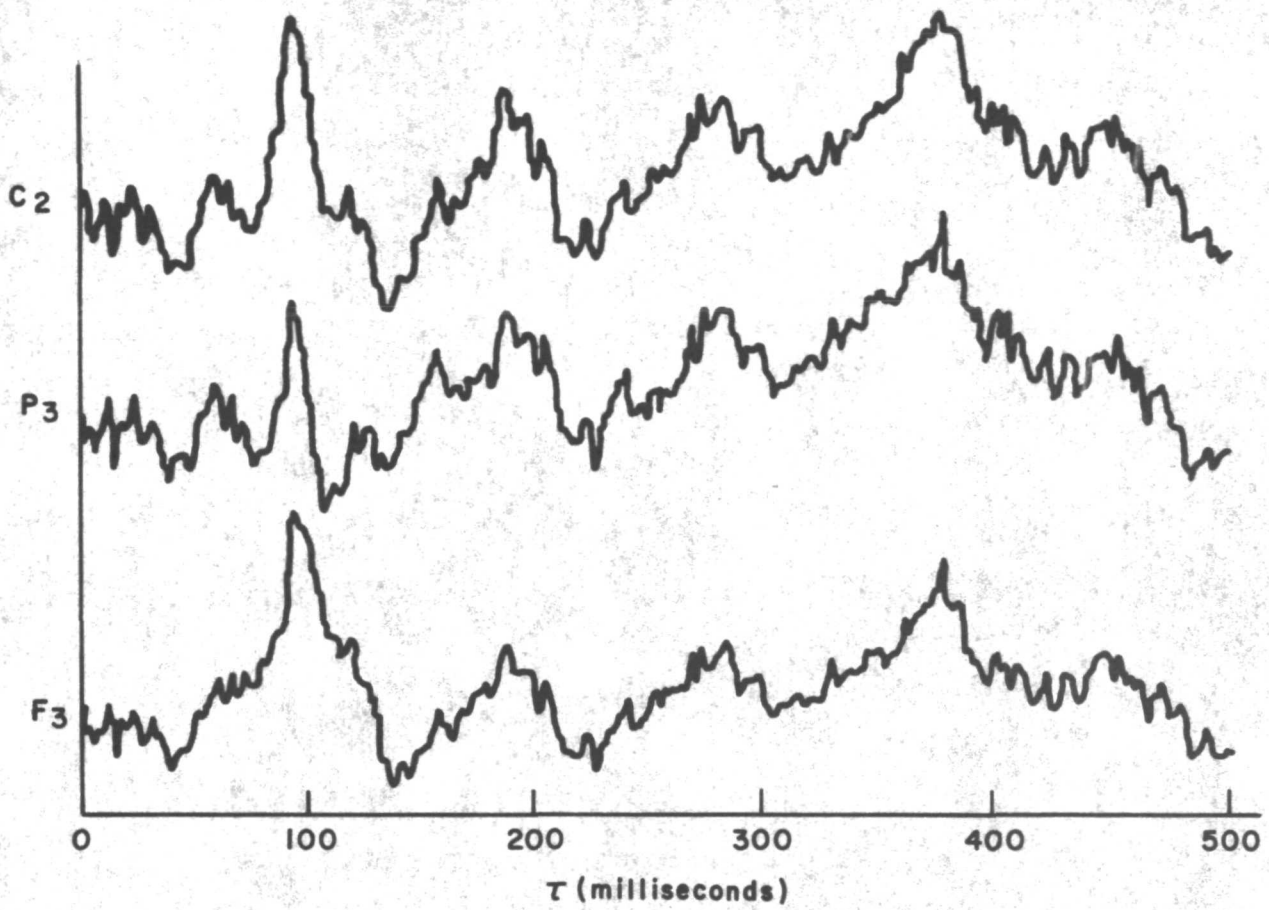
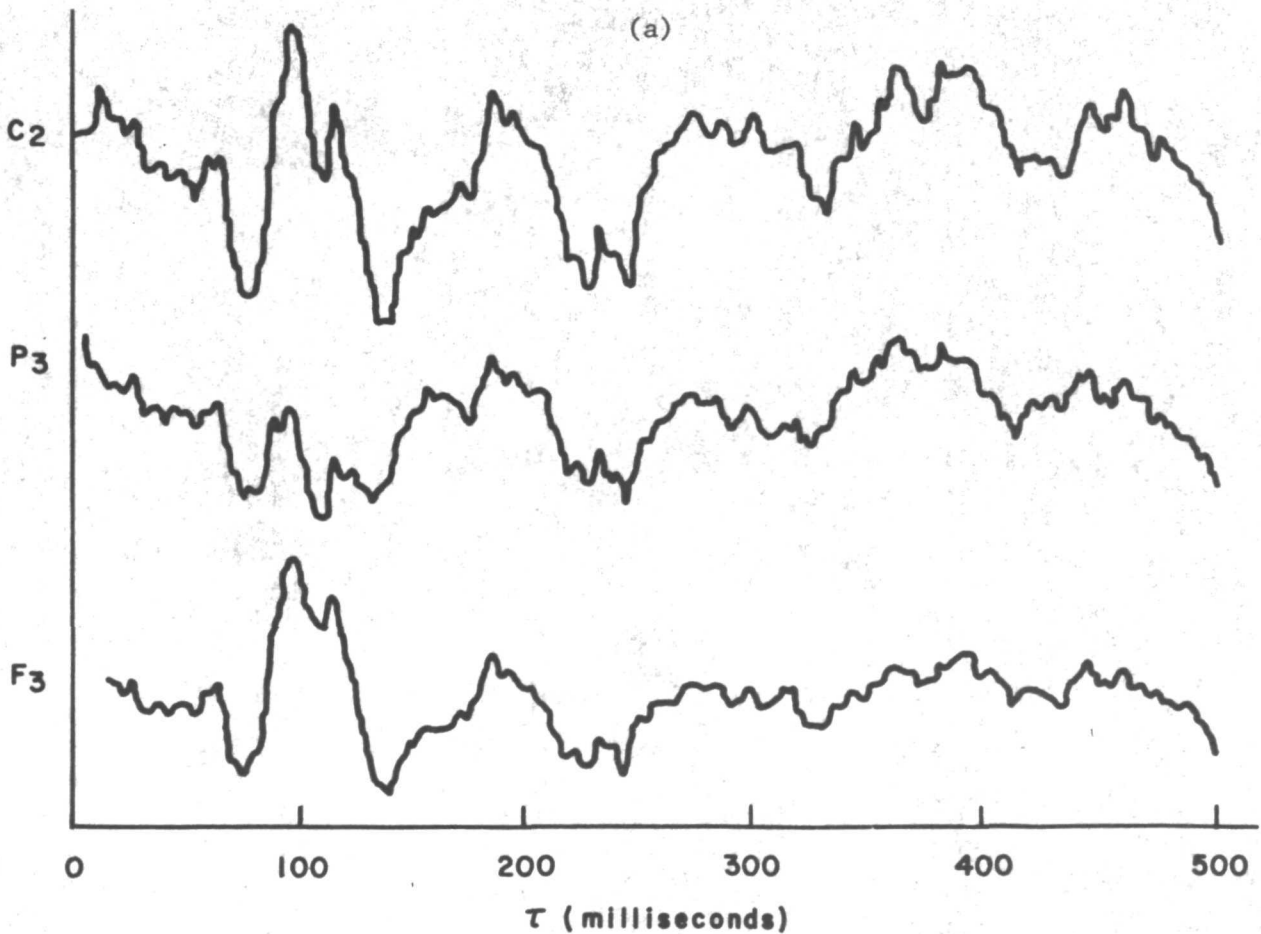

Figure 9. Visual Evoked Response with Conventional Electrodes (Average of 200 Trials).



(a)



(b)

Figure 10. Visual Evoked Response with EEG Helmet (Average of 200 Trials).

First, a subject was fitted using EKG solution and conventional silver dish electrodes mounted with collodion. Three electrodes were employed, one each at the C_2 , P_3 , and F_3 positions, with all signals referred to the left ear. Visual evoked potentials, obtained by using a strobe lamp, were recorded for 200 stimuli. The data were averaged by computer and the average evoked potential for each lead was plotted (See Figure 9a). The test was repeated using the same electrodes in order to obtain some idea of the variation to be expected with this subject. These data are plotted in Figure 9b.

The conventional electrodes were removed, the skull carefully cleaned to remove collodion, and the helmet was fitted. Electrode placement was adjusted to obtain, as nearly as possible, the same locations as in the previous trials. The subject was then stimulated using the strobe for 200 flashes as before, and the averaged EEG curve for each lead was plotted (See Figure 10a). Since the electrode conductor in the helmet electrode is actually saline solution, it was decided to inject saline into the electrodes (as might accidentally occur occasionally). Saline was injected until it ran down the sides of the patient's head and the tests were repeated. The data from this test are shown in Figure 10b. It can be clearly seen that excess saline has little observable effect on the records. It was concluded from these tests that (1) the helmet technique provides EEG records that are of comparable quality to those using conventional techniques, and (2) the helmet method is faster and easier than conventional techniques if more than one electrode is involved. Further, it would be significantly faster and easier for the application of seven electrodes on children as is desired by the researcher.

The EEG helmet will definitely solve the researcher's problem: however, during the time period in which the EEG helmet trial was arranged, another technique developed under a NASA contract at UCLA was identified. This unit employs techniques basically similar to those used in the EEG helmet. In the UCLA-developed unit, the cap is made from a stretchable polymer and is donned much like a bathing cap. Because it stretches, electrode adjustment to fit each child's skull is not required. It is significantly lighter in weight than the helmet, which is a distinct advantage with children. One further advantage, at least in a screening program such as that planned by the researcher, is that the electrode positions and spacings remain relatively constant.

The EEG helmet has fully demonstrated its capability to solve the researcher's problem, and efforts are being made to obtain one for his use through the reengineering activities of TUD.

PROBLEM MISC-6 *Motor for Powering Prosthetic Unit*

A small powerful motor developed for space craft may solve a significant problem in prosthesis for children born without arms and legs.

The researcher is working with a boy four years old who was born without arms and legs. With prostheses and intensive training the boy could stand up and walk independently at the age of 19 months. He is now using both legs and arms prostheses. In addition to walking, he can eat, drink, and draw using his prostheses.

The basic problem is to design a prosthesis that will permit the boy to go up and down stairs. The researcher has contacted many specialized prosthetics and rehabilitation centers both in Europe and the United States. Unfortunately, little practical experience is available to draw upon in the rehabilitation of one so severely handicapped. The researcher has evolved a design in which the prosthetic legs can be made to telescope by means of a drive motor in the leg. (See Figure 11). Such a telescoping prosthesis would allow one of the legs to be lengthened to the height of the stair tread so that the other foot could be placed on the next step. The boy would then transfer his weight to the upper leg, and the extended leg would be shortened to the proper height to permit him to stand on the level with both feet on the upper stair tread. The process would then be repeated, thus allowing the boy to traverse the stairs.

The basic problem in the design is to locate a motor that is small and lightweight enough to fit into the prosthetic leg while at the same time powerful enough to lift the entire weight of the boy. Hard and fast specifications on the motor performance are somewhat difficult to assign. As a result, information on the smallest and most lightweight motors that can be obtained and which can provide the power to lift approximately 50 pounds a distance of eight to ten inches within a time span of five to ten seconds is desired.

Size and weight are the primary constraints, provided the motor can produce sufficient power. Because the final design of the prosthesis will be determined by the motor, we hesitate to assign a minimum size and weight. Rather, the smallest, lightweight motors with adequate power which can be identified will be considered. When this has been established, studies will be made to determine if the prosthesis design parameters can be modified sufficiently to permit implementation of a prosthesis which the boy can effectively use.



Figure 11. Hydraulic version of prosthesis.

An authority on small motors at Duke University was consulted. He advised us that brushless DC motors designed under NASA contract by Sperry Marine Systems Division to provide motive power in positioning satellite solar panels and unfurling antennas were the most likely to fit this particular application. Information on the motors was obtained from Sperry and forwarded to the problem originator. After reviewing the motor characteristics with his technical staff, the researcher has decided that these motors are well-suited for fulfilling the motive function in the prosthesis for the young boy. At the present time, efforts are being made to obtain the motors.

PROBLEM NHLI-1 *Intramyocardial Stress Measurement*

A pressure transducer designed by NASA for aerospace use is proving useful in basic heart research.

Myocardial infarction is a process resulting in the death of an area of the heart muscle following a reduction in the blood supply to that area. Acute myocardial infarction is the main cause of premature death in the population of the developed countries. Myocardial infarction can usually be diagnosed by electrocardiography; however, no method is available for determining the precise location of the affected tissue which is necessary to assure the success of surgical procedures for repairing the injured muscle.

Since the damaged or dead tissue (whose size and location is dependent on degree of compromised blood supply) results in a "weak area" of the heart muscle, it is expected that a measurement of the forces sustained during the successive contraction and relaxation of the heart will differ from similar measurements made in unaffected areas. The myocardium cannot be treated as though it were a fluid since the heart develops tension in its muscle fibers while exerting pressure on its contents. If the heart is treated as a solid, stresses upon any one element can be resolved into three purely compressive or tensile stresses mutually perpendicular to each other. A probe which could be used to make stress measurements within a small region of muscle tissue would lead to a refined location of the region which needs to be removed by surgery. It would also improve our understanding of hemodynamic performance and several other pertinent physiological problems. This should in turn lead to improved surgical procedures and, therefore, to a higher probability of successful recovery for thousands of persons who must undergo surgery for this disorder each year. The physiological assessment might also provide rationale for other therapeutic interventions.

A search of the aerospace literature uncovered many interesting types of pressure and stress transducers; however, none was well suited for the application in question. The Team was aware of two NASA-developed pressure transducers that are significantly smaller than commercially available devices: one developed by Mr. Grant Coon at Ames Research Center, the other by Dr. Wilhelm Rindner, formerly at Electronics Research Center (ERC). The Ames transducer is potentially applicable to this problem; however, more developmental work is necessary. The ERC transducer appears to offer a possible solution to the problem.

The Team loaned an ERC transducer to the problem originator, Dr. Karl Weber, of the National Heart and Lung Institute (NHLI) and assisted in a preliminary experiment with a live animal. Although the preliminary experimental results are not yet fully understood, it is evident that mechanical stress in the heart muscle does undergo changes as the region surrounding the transducer becomes ischemic. Additionally, Dr. Weber has detected changes in the myocardial stress characteristics as the hemodynamic properties of the heart are altered by the administration of certain drugs. Dr. Rindner has provided the transducer in the form of a needle in order to make it somewhat more suitable for probing the heart; evaluation tests are underway. (See Figure 12).

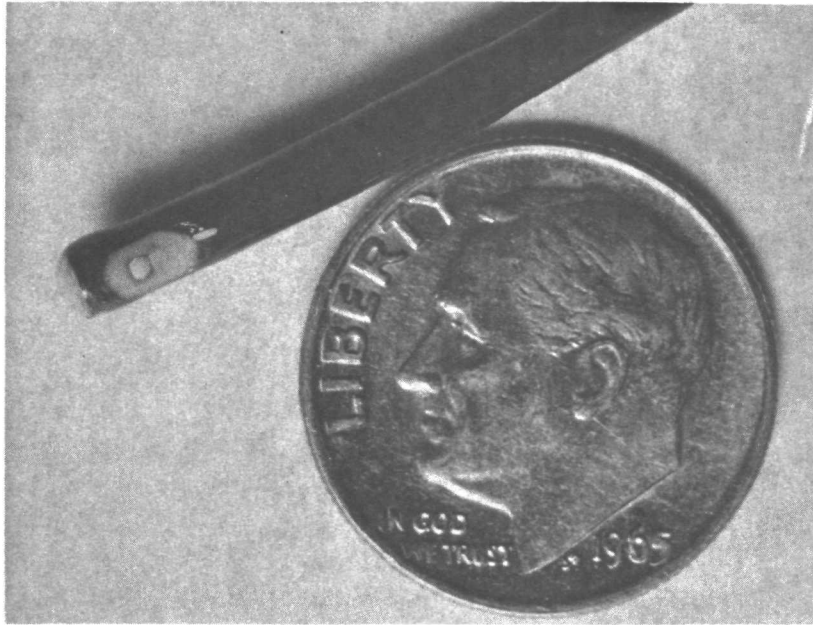

Figure 12 NASA pressure transducer. (ERC)

PROBLEM VAM-2 *Diagnosing Gait Abnormalities*

A suit developed for NASA's 1973 Skylab flights may prove to be a key factor in the diagnosis of gait abnormalities.

Thousands of Americans suffer loss or impairment of their limb functions. Artificial limbs and therapeutic treatment offer a degree of rehabilitation for many of these persons who are then able to resume many of their normal activities. Presently, gait abnormalities are diagnosed and progress is followed by a physician's visual observation of the patient while walking. The physician has little trouble in determining the type of affliction (e.g., Parkinson's disease, cerebral palsy) by his observation of the patient during walking; however, it is difficult to determine the degree of impairment of gait function. It is perhaps more difficult to quantitate progress made by the patient. This is an important task of the physician since therapeutic treatment must be tailored to a particular individual's needs. More rapid and more complete recovery might be expected if the gait abnormalities could be analyzed in more than a subjective manner.

An equally important need for quantitating gait abnormalities exists in the design and fitting of prosthetic limbs. Here quantitative gait information might be used to design better prostheses. In addition, the prosthesis adjustments could be refined to yield a more normal pattern of walking.

Preliminary experiments employing triaxial accelerometers attached to various points on a patient's leg indicate that a knowledge of the acceleration of the limb segments while walking might be used to detect and quantitate gait abnormalities. It is desired to find a method of determining the acceleration of the body's lower limb segments.

The problem was posed to Mr. John Samos, Technology Utilization Officer at Langley Research Center (LRC), who contacted an LRC engineer experienced in accelerometer instrumentation. Discussions with this engineer revealed that there were several problems involved in instrumenting a patient with accelerometers and that an alternate approach should be considered. He suggested that we contact the LRC staff concerned with the Crew Vehicle Disturbances study which is scheduled for NASA's 1973 Skylab mission. This experiment was designed to assess the effects of crew motion on the attitude stability of a manned spacecraft. To conduct the study, a device for determining the position of an astronaut's limb segments relative to the torso was developed. This system is actually a type of exoskeleton incorporated into a pair of coveralls which measures joint rotations in real time. (see Figure 8).

Team members discussed the applicability of this system to the study of pathologic gait and concluded that the system provides an excellent method of determining acceleration of the body's limb segments. In addition, the system yields the actual position of the limb segments in space which will be of even greater benefit than the acceleration data alone. The Team has made arrangements with the principal investigator for the Skylab Crew Vehicle Disturbances experiment to obtain the limb position sensing system on loan to assess its potential in rehabilitation of patients with gait abnormalities.

PROBLEM WWRC-11 *A Valve to Permit Easy Emptying of Leg-Bag Urinals by Handicapped Patients*

Many handicapped people do not have control of their urinary functions. These people must wear a polyethylene bag strapped to their leg which collects the urine. The present leg-bag urinals have a tube coming out the bottom end of the bag which is used to empty the urinal. The tube is closed by a clamp which compresses the tube thus preventing the flow of urine except when the patient wishes to empty the bag. The presently used clamp must exert a significant amount of pressure on the tube in order to eliminate all leakage. Unfortunately, the clamp is very difficult to operate in that it requires a large amount of force and significant manual

dexterity to either open or close. The people who wear these leg-bags generally have severe disabilities and experience great difficulty in operating these clamps. Another means of draining the leg-bag urinal is desired. Whatever valving system is employed must permit easy operation. Exertion of pressure is the most effective mode in which these patients can perform a controlled action. Therefore, the best method for operation as far as the handicapped patient is concerned would be in a compression mode; that is, it is desired that the valve technique be capable of operation by the application of pressure not to exceed two pounds, preferably less.

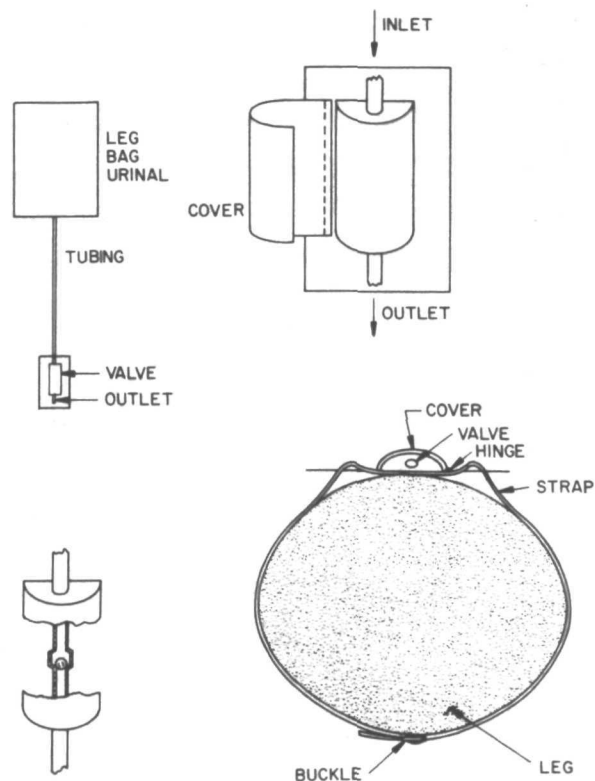

Figure 13. Urinal leg-bag valve (prototype).

When this problem was received, the Team realized that the specially developed check valve used in the fabrication of Applications Engineering Project WF-3, "Prosthetic Urethral Valve," might potentially be useful in this particular application since this check valve could be actuated by a simple pressure application. The details of this check valve were discussed with the medical investigator. As a result of the evaluation of this suggestion, it was concluded that the check valve from the prosthetic urethral valve had potential as a solution to this problem. In order to perform an actual "in use" evaluation of the valve, one was obtained from Dr. McCartney at the University of Virginia who performed the application of engineering on the prosthetic urethral valve. The main question was whether or not the patients

could actually actuate the valve whenever desired. The "in use" evaluation by the medical investigator has indeed determined that the patients could operate the valve very effectively.

It was also apparent that the small diameter of the valve would require an inordinantly long time to empty the leg-bag urinal. The medical investigator now feels that if two prototype valves can be obtained and modified to the proper size, then full evaluation could be completed. In addition, the medical investigator intends to contact commercial suppliers to discuss the possibility of having a commercial supplier manufacture these devices for widespread use. The Team is fabricating one of the valves for evaluation by the medical investigator. (see Figure 13).

PROBLEM WWRC-7 *A Signalling (Nurse-Call) System for Multiple Sclerosis Patients*

A NASA engineer has designed a call system for multiple sclerosis patients which is being evaluated in a major rehabilitation center.

The Woodrow Wilson Rehabilitation Center (WWRC) of the Virginia Department of Vocational Rehabilitation is planning a new building for the Medical Services Division. Among those who will be housed in the new building are a number of multiple sclerosis patients with severe disabilities. Such patients have little or no use of hands or feet. Consequently, they must depend on the services of nurses for practically all of their needs. Their disabilities are often so severe that they cannot accomplish the relatively simple task (for a person without disability) of operating the call button used in most hospitals to initiate signalling system.

The patients requiring such a signalling system generally have voluntary control of one or all of the following functions which could conceivably be used for control:

- (1) Breath (respiration)
- (2) Eye movement and blink
- (3) Head motion -- the head can generally be raised two inches and can be turned from side to side.

Most patients cannot change their positions except for the head so that they remain essentially stationary unless moved by attendants. It is desirable that the signalling system be capable of activation by a patient sitting in a wheelchair beside the bed. Generally, complicated electronic and optical systems of high sensitivity which require frequent adjustment or maintenance are undesirable because of the lack of skilled technicians. On the other hand, if an electronic or optical system of great ruggedness and high reliability could be achieved, it would certainly be given consideration. In summary, a system capable of operation by one of the three control mechanisms available to the patient is required, but ease of maintenance and high reliability cannot be ignored as constraints on this problem.

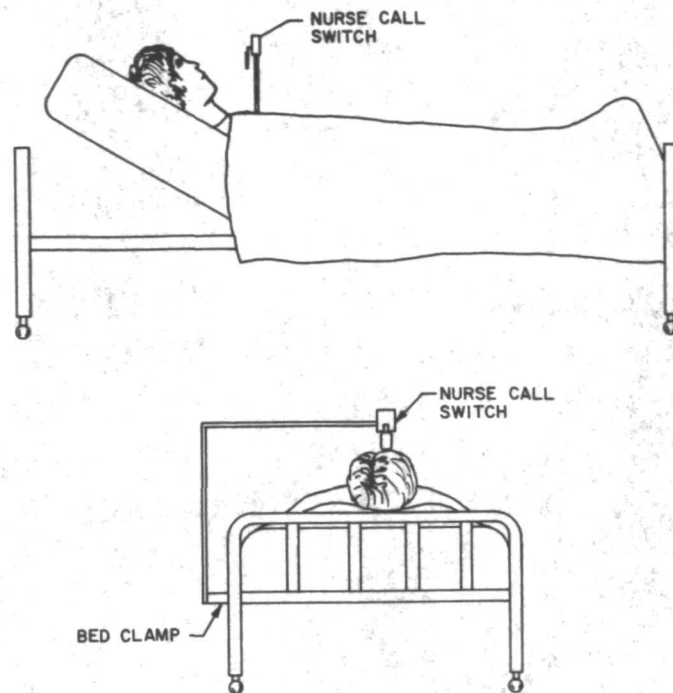

Figure 14. Breath-actuated switch.

The Southwest Research Institute (SwRI) Team has been working for some time with the Marshall Space Flight Center and the Langley Research Center on a device to permit paraplegics to perform a number of functions from their beds. The system which is being developed employs a breath-actuated switch suggested by personnel at the Langley Research Center along with a logic circuit which permits the patient to control a number of electrically **activable** devices from his bed. The system being developed for the application identified by the SwRI Team is more complex than that required by the problem at WWRC. The Problem at WWRC is merely to call the nurse and, essentially, a substitute for the hand activated nurse-call button is required. (see Figure 14). At WWRC a commercially available unit is used to permit communication between the nurse station and the patient by means of an intercom system. The system is activated by a call button. Although the problem at WWRC does not require the complexity of that required at SwRI, the breath-operated microswitch suggested by LRC as the control element for the more complex system can be used in conjunction with the commercially available system at WWRC. The Langley suggested breath-actuated switch appears to be completely compatible with the current installation at WWRC. This, of course, is a very significant advantage. One of the breath-actuated switches has been obtained for evaluation at WWRC. Should the evaluation prove that the breath-actuated switch is a viable solution to the problem, it is anticipated that WWRC will convert all multiple sclerosis and paraplegic call stations to the use of the breath-actuated microswitch.

PROBLEM WWRC-13 *A Remotely Controlled Device to Pick Up and Transport Single Sheets of Paper*

A NASA engineer has designed a device which may have significant benefit in the vocational rehabilitation of severely disabled quadriplegics. The number of vocations available to such handicapped people is extremely limited. Many such patients maintain so little control of their musculature that the only basic proficiency which they can acquire is to punch pegs or to depress keys on a keyboard. The Training Division of the Woodrow Wilson Rehabilitation Center is constantly seeking vocations for which these patients can be trained. The Friden Business Machine Company has a bookkeeping machine called Add-Punch. With this machine, a bookkeeping function can be accomplished by merely entering data into the proper categories on the Add-Punch machine keyboard.

Quadriplegics can operate the machine in as far as entering the data is concerned, but generally the data are not in a form which is readily visible to them. In most instances, businesses which would employ a quadriplegic to do this sort of activity (perhaps in his home) would bring a stack of tickets to the quadriplegic for him to enter into the machine. This poses a difficulty since the quadriplegic cannot reach over and remove the tickets from the stack. Consequently, he cannot gain access to the tickets underneath the top ticket unless someone is present to transport the top ticket off the pile and into another pile as he enters the data. A simple device which can be remotely controlled by means of a single button is required to pick up or attach to the top ticket on a stack and remove that ticket to another spatial position nearby. Stacking from one tray to another is desirable, but it is not absolutely necessary that the tickets be maintained in a neat stack as they are removed. The person who delivers the tickets would be able to stack them in the tray or other device for holding the tickets in some specified position as needed by the pickup device. Since the quadriplegic will certainly be marginal in performing even this kind of task, the cost of implementing any solution to this problem must not be so high as to make employment of a quadriplegic in this task unfeasible from an economic standpoint. A cost of \$200 or less would not be considered prohibitive in this application.

This problem was discussed in the Langley Researcher Newspaper by Mr. John Samos, Technology Utilization Officer at the Langley Research Center. In June 1971 we received a suggested solution from Mr. George M. Dudley of the Force Measurements Section, Instrument Research Division of the Langley Research Center. The suggested solution involved a vacuum pickup with a transport mechanism operated by an electric motor. Mr. Dudley was interested in this problem and decided to fabricate a working model shown in Figure 15 for evaluation by the researcher at the Woodrow Wilson Rehabilitation Center. In December the unit was completed, and the Team visited Langley for a demonstration. The device will be placed in the hands of the researcher at the Woodrow Wilson Rehabilitation Center for evaluation. It is expected that a refinement of the model to reduce size and mechanical complexity will be undertaken should this phototype model be acceptable to the researcher.

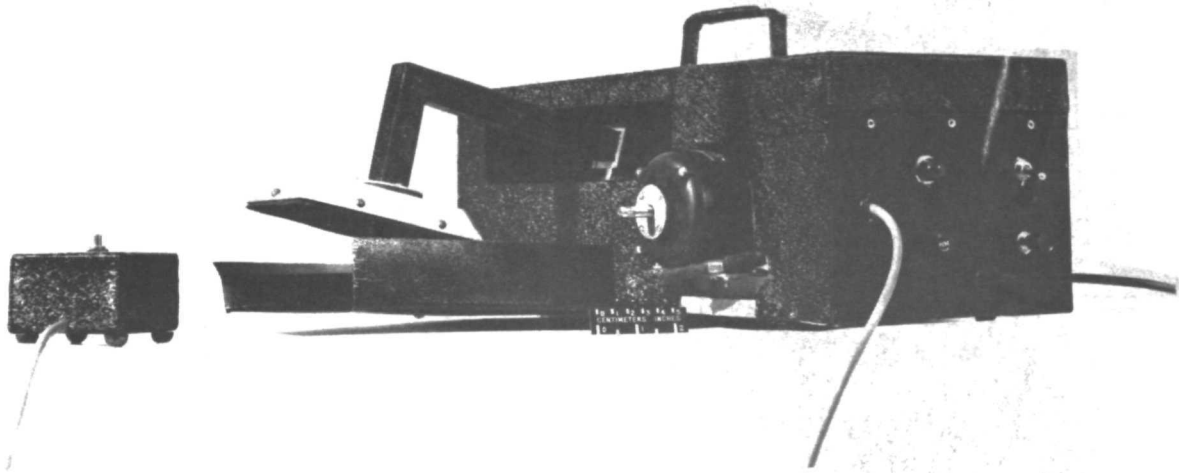

Figure 15. Paper transport device.

2.3 Impacts

The Application Team's efforts often provide a significant benefit to the researcher even though no technology application has been accomplished. During this reporting period, Team activities had a significant impact on the researcher's activities in three such problems which are discussed in the following summaries:

PROBLEM NCI-7 *Method of Fast Warming of a Frozen Liquid*

Leukemia, a disease which kills about 15,000 Americans annually is characterized by a proliferation of the tissue which forms white blood cells. Treatment of leukemia involves killing the cancerous white blood cells in the blood and in the bone marrow so that normal white cell production cannot occur.

When this loss of bone marrow occurs, white cells must be resupplied to the patient from a bank or storage facility of white cells. This is impossible

at present because adequate storage procedures are unavailable. One part of the storage problem is a controlled freezing method which is the subject of problem number RTI/NCI-4, "Method of Controlled Rate of Cooling in Liquids." The second part of the storage problem being studied by the National Cancer Institute (NCI) is the warming or thawing of the frozen white blood cells which is the subject of this problem.

One important parameter in the successful warming of cells is believed to be the rate of temperature change because experiments with spleen cells have indicated that very fast warming rates can significantly increase the yield or survival rate of frozen cells.

The present method for warming cells is an infrared heating system for the cells contained in a flat Teflon bag. (To prevent contamination of the cells, it is desirable that any new technique allow the use of a Teflon container). This infrared system is unsuitable because the cells are warmed neither uniformly nor fast enough. Because of the high rate of thermal energy transfer required, it is unlikely that any system utilizing conduction as the major mode of heat transfer will be sufficient.

The basic requirement is to have a method of rapidly and uniformly warming a volume of frozen liquid from -150°C to room temperature. The method should be capable of warming a 20 milliliter volume of cells from -150°C to room temperature in one minute. The thermodynamic properties of white cells are not known, but a good approximation is that they are similar to water. A problem statement was circulated to the NASA Field Centers, and the use of microwave heating was suggested by Mr. Charles H. Gresslin of Lewis Research Center. Mr. Gresslin's idea was relayed to the NCI researcher who stated his strong interest in the approach. The Team then calculated the microwave requirements and identified a commercial microwave oven as a possible solution. Although this oven had been used for other biological purposes, it had not been used for thawing of frozen or white cells.

After careful study of the microwave oven characteristics, the researcher has ordered the oven. The use of this oven will enable the researcher to determine whether the proposed rapid warming of frozen white cells is a valid solution to the cell preservation problem. Successful conclusion of these tests will permit a partial solution to the major problem of cell preservation.

PROBLEM WF-67 *A Filter to Separate Physiologic Data Occurring at Nominal Heart Rates from Lower Frequency Data*

At the Bowman Gray School of Medicine, large quantities of data have been and are being accumulated on blood flow, blood pressure, heart rate, and other measurable and derivable quantities that are related in time to the heart rate. These data are recorded on magnetic tape and strip charts. The heart rate is, of course, periodic, nominally occurring approximately once per second. Superimposed on this data, and appearing as noise, is a much more slowly occurring waveform. The undesirable long period data appear to be related in some fashion to the respiration cycle. The amplitude of this slower rate

waveform is large with respect to the heart rate related data. It causes serious baseline distortion and makes interpretation of the data difficult. The researcher wishes to obtain a filter which will separate the low rate waveform from the heart rate data. The researcher has requested that the Team aid him in identifying a low-cost filter design that can be used in this application.

The researcher made inquiry to the Team independently of this problem concerning a source for a high rate cardi tachometer to be used on primates. The Team suggested a Model MTH cardi tachometer manufactured by Microtronic Corporation, Carrboro, North Carolina. The design of this unit makes use of R-wave detection principles evolved by NASA. The researcher purchased one of the Microtronics cardi tachometers and has been using it in his laboratory. This unit has input filters that are very effective in removing the unwanted, respiratory-related signal fluctuations. It has been used in a number of applications, and tests have shown it to satisfy all the problem requirements.

PROBLEM WWRC-5 *An Improved Connector for Polyvinyl Tubing*

Many males with urinary incontinence wear a leg-bag urinal which is supported on the inside of the leg by straps around the leg. Whenever urine is emitted by the patient, it is conducted by gravity through a sheath and one-quarter inch polyvinyl tubing to the leg-bag which functions as a collector and temporary storage for the urine. When the patient retires at night, the leg-bag can no longer be used, and a night bag which is attached to the patient's bed at a level lower than the patient is used. This means that the tubing must be removed from the leg-bag and attached to the night bag. Presently, the connection to the leg-bag consists of a sleeve slightly larger than the tubing, over which the tubing must be forced to complete the connection. This requires considerable grip and strength in the hands. Removal of the tubing from the leg-bag is much more difficult and can be quite hard for a person of normal hand strength to accomplish. Many of these patients have reduced strength and partial loss of function in their hands, so it is even more difficult for them. Upon arising in the morning, the tubing must be removed from the night bag and connection again made to the leg-bag. It is extremely important that these patients be made as self-sufficient as possible, not only from a practical standpoint, but also to lower their sense of dependence and thus improve their mental outlook.

Because of the difficulty presented by the connectors now in use, many of these patients require assistance both in the evening upon retiring and in the morning. This is extremely undesirable both from the patient's and the therapist's viewpoints. A new type of connector which requires less strength to connect and disconnect but which provides a leak-proof connection is desired. It is also desirable that use of the connector not require highly coordinated motions or great skill.

The month following acceptance of this problem, Mr. R. R. Zimmerman of George Washington University suggested that a commercially available connector from the Cole-Parmer Instrument Company might prove to be a solution to this problem.

Information on the connector was obtained from the manufacturer and forwarded to the medical investigator who then ordered one of the connectors to determine its applicability to this problem. The connector has been evaluated in the clinical environment and has been found to be completely acceptable as a solution to the problem. This problem. The connector has been evaluated in the clinical environment and has been found to be completely acceptable as a solution to the problem.

3.0 SUMMARY OF TEAM ACTIVITY DURING REPORTING PERIOD

3.1 Problem Activity Summary

The following is a summary of project activity undertaken by the RTI Team during the period April 1, 1971, to December 31, 1971.

| | |
|--|----|
| <i>New Problems Accepted</i> | 38 |
| <i>Problems Rejected</i> | 6 |
| <i>Problems Inactivated</i> | 50 |
| <i>Problems Reactivated</i> | 2 |
| <i>Total Problems Currently Active</i> | 77 |
| <i>Preliminary Problem Statements Prepared</i> | 38 |
| <i>Problem Statements Disseminated</i> | 3 |
| <i>Responses to Problem Statements</i> | 22 |
| <i>RDC Computer Searches Initiated</i> | 25 |
| <i>Impacts</i> | 3 |
| <i>Potential Technology Applications</i> | 9 |
| <i>Technology Applications</i> | 5 |

A description of currently active problems categorized by health area is attached as Appendix B.

Table I lists the currently active problems by impact area.

3.2 Presentations by Team Members at Conferences, Meetings, and Symposia

On May 6, 1971, Dr. F. T. Wooten presented a discussion of the Application Team Program to the Sanderson High School in Raleigh, North Carolina.

On May 18, 1971, Mr. Ernest Harrison presented, by invitation of the Long Island Rehabilitation Association, a discussion of the Application Team Program with particular emphasis on the relationship of the program to rehabilitation problems.

On May 18, 1971, Dr. F. T. Wooten presented a discussion of the Application Team Program to two civic clubs in eastern North Carolina.

On October 6, 1971, Dr. F. T. Wooten presented, by invitation, a paper entitled "Future Needs for Biomedical Transducers" at the Transducer Conference sponsored by the Institute of Electrical and Electronic Engineers in Washington. This paper is attached as Appendix C of this report.

On October 14, 1971, Mr. Ernest Harrison presented the keynote address at the Regional Physical Therapist Association meeting in Asheville, North Carolina. This presentation included a discussion of the Application Team Program as well as a movie of the Apollo 15 flight.

On November 1, 1971, Mr. Ernest Harrison presented the keynote address at the annual American Occupational Therapy Association meeting in Cleveland. This paper is attached as Appendix D of this report.

On November 17, 1971, Mr. E. W. Page presented Dr. Wooten's paper entitled "Advancements in Medicine from Aerospace Research" at the National Space Congress in Huntsville, Alabama. This paper is attached as Appendix E of this report.

3.3 Visits to NASA Field Centers

In order to continually increase Team knowledge of NASA research, members make frequent visits to field centers for technical discussions. During this reporting period, visits were made to Goddard Space Flight Center, Langley Research Center, Lewis Research Center, Jet Propulsion Laboratory, and Marshall Space Flight Center.

3.4 Association for the Advancement of Medical Instrumentation (AAMI)

In order to enhance the impact on the medical community of technology applications, the Team is actively seeking industrial manufacture of marketable devices. One approach being used is a committee within the Association for the Advancement of Medical Instrumentation (AAMI) which is considering ways to advise and interest the industrial community in applications of technology. The second meeting of this committee was held on November 3, 1971, in association with the Conference on Engineering in Medicine and Biology in Las Vegas, Nevada. During this meeting, a number of significant problem areas were discussed. It is interesting to note that a major conclusion of the committee was that simplification of the patent right availability procedures is not a significant factor in whether a manufacturer will consider a particular product. A second significant point concerned how a particular industry selects a new product for marketing. This discussion seemed to indicate that some initial market research was necessary in developing significant interest in a new product. This particular point will be explored by correspondence of committee members before the next meeting of the committee in April, 1972.

4.0 SUMMARY OF BIOMEDICAL APPLICATION TEAM STATUS AT USER INSTITUTIONS

4.1 Introduction

In Section 1.4 of this report, the 14 medical institutions participating in the RTI Application Team Program were listed. In order to put into perspective the relative activity and history of the activity at each school, the following brief summaries are presented.

4.2 Summary Status for User Institutions Participating in the Program on December 31, 1971

Duke University Medical Center - This institution has been active in the Application Team Program for five years, and a total of 84 problems have been considered at this school. During the past two years, there has been a noticeable slackening of activity because of the reduction in Federal funds at this school.

Bowman Gray School of Medicine of the Wake Forest University - This school has been active in the Application Team Program for five years during which time a total of 107 problems have been considered. Activity has slowed noticeably in recent months and this lower level of activity is expected to continue at this school over the next year.

University of North Carolina Medical School and Dental School - A total of 90 problems have been defined at the schools of medicine and dentistry during the past five years but activity at the present time is at a virtual standstill. The primary reason for this is the lack of a suitable consultant at this school making it very difficult for the Team to reach the potential users of the program. No change in the low activity level at this school is anticipated in the near future.

Tulane University School of Medicine - Team activity started at Tulane in December 1969 making this school one of the more recent additions to the Application Team Program. The cooperation and enthusiasm of the Tulane staff have contributed to a very successful program. Thus far, a total of 26 problems have been considered and activity is expected to continue at a very satisfactory level.

Institute of Rehabilitation Medicine of the New York University - Since activity started in this school in April 1969, a total of 26 problems have been considered. This institution is a small group within a large university and most of the acceptable problems have already been considered. No further activity is anticipated with this institution.

National Cancer Institute - Activities at the National Cancer Institute (NCI) started in August 1969, and a total of 12 problems have been considered. NCI personnel have expressed satisfaction with the success of the program and continued activity is anticipated during the coming months.

Ochsner Clinic and Foundation - The Ochsner Foundation is a small research group associated with a private clinic in New Orleans. Only two problems have been defined at this institution but both problems have a high probability of solution.

Virginia Department of Vocational Rehabilitation - This department operates the Woodrow Wilson Rehabilitation Center. An unsolicited request for Team assistance was received and problem definition started in November 1970. A total of 16 problems have been considered at this institution. Activity over the next year will emphasize implementation of existing potential solutions.

National Heart and Lung Institute - Activities started within the Medical Devices Application Branch of NHLI in September 1970. A total of seven problems have been defined and continued interaction is anticipated with this prestigious institution.

National Institute of Environmental Health Sciences - This is the smallest institute of the National Institutes of Health and activities started here in October 1970. A total of three problems have been accepted and a low level of problem activity is anticipated from this institution.

Emory University School of Medicine - Activities at this school started in January 1971 and a total of sixteen problems have been considered. Continuing substantial activity is anticipated at this school.

University of Miami School of Medicine - In answer to an unsolicited request, the Team initiated activities in December 1970 at this institution. In September 1971 a presentation was made to the Dean of Medicine and a substantial problem activity level resulted.

Medical University of South Carolina - In answer to an unsolicited request, the Team initiated activities at this school in March 1971. Activities are presently concentrated in one group of individuals in the Department of Surgery but efforts are being made to expand this activity to other departments.

5.0 APPLICATIONS ENGINEERING PROGRAM

Selected problems have been accepted for implementation of technology under the Applications Engineering Program. In the program, the technology is actually implemented by NASA. Activities for these seven problems are presented in the following summaries.

PROBLEM DU-31 *Catheter-Mounted Pressure Transducer*

A pressure transducer developed for use in the aerospace program has been modified for measurement of pressure in human hearts.

Heart disease is the major cause of death among the American people. The disease affects every age group, and it is extremely interesting that the youngest age group, infants, demonstrates nearly all varieties of abnormal cardiac condition. Thus the study of pediatric heart diseases is of major importance. Many types of abnormal heart conditions in children can be surgically corrected, but proper diagnosis becomes of paramount importance. The correct diagnosis of heart disease in children requires very careful measurements of pressure and volume of the heart. The arteries and heart chambers are very small and require an unusually small catheter for making various measurements. One of the measurements of great importance is pressure in the aorta and all four chambers of the heart. This pressure measurement is more difficult in small children because heart rates can range as high as 300 beats per minute. Thus the pressure transducers must be able to measure rapid changes in pressure and very small gradients in pressure in order to detect the abnormalities in heart condition.

A major research effort at Duke University Medical Center is devoted to understanding the heart diseases in children. In particular, the research is devoted to determining a correlation between pressure changes in all four chambers of the heart with motions of the chest wall. The motions of the chest wall can be detected by an apex cardiogram. Thus a correlation will be made between a measurement technique requiring penetration of the heart and a measurement technique entirely external to the body. It is necessary to measure pressure, but the existing methods of measuring pressure do not have sufficient sensitivity, frequency response, or size capability. Also fluid-fill catheters which are commonly used cause significant overshoot in the contraction pressure waveform. Thus a new pressure measuring device is required.

A pressure transducer with size #5 French (1.5 mm) or smaller is required. The pressure range is -30 mm to +300 mm Hg. The maximum frequency of response is undetermined but frequencies as high as 100 Hz may be encountered. Pressure resolution of 1 mm Hg is required, and temperature compensation from 35°-40° C is required. The transducer should be mounted on the side of a catheter to prevent erroneous readings due to motion of the catheter against the heart wall.

The solution to this problem appears to be the tunnel diode transducer developed by Dr. W. Rindner at Electronics Research Center. Dr. Rindner has formed his own company, Device Research Incorporated and is presently offering the NASA-developed transducer. The Duke researcher has examined the specifications of the Rindner TD-1 Transducer and believes that this will solve his problem.

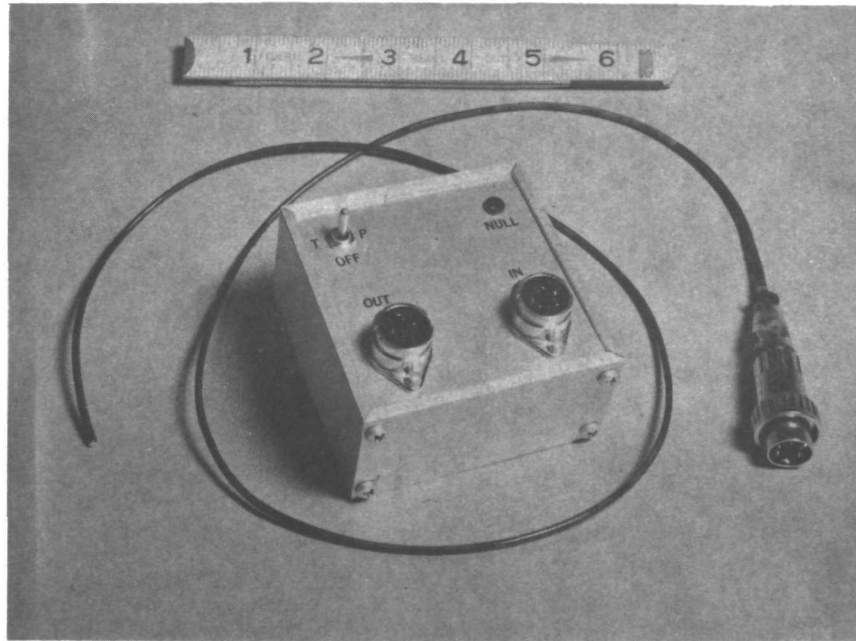

Figure 16. Tunnel diode pressure transducer.

The TD-1 pressure transducer, shown in Figure 16, is presently undergoing tests at Duke University Medical Center to determine its characteristics in animal experiments. Initial tests indicate excellent sensitivity but some problem in thermal draft. Dr. Rindner is now modifying the transducer to solve this problem.

PROBLEM NCI-3 *Automatic Blood Pressure Measurement of Critically Ill Patients*

Equipment designed to monitor astronauts during ground training is being used in the monitoring of leukemia patients. Leukemia, a major form of cancer, is a disease characterized by a self-penetrating proliferation of white blood cell forming tissue.

The National Cancer Institute (NCI) is conducting a vigorous program directed toward finding the causes and cure for this disease. In the clinical phase of this program, a problem exists in the early detection of shock which is defined as a sudden reduction in the volume of circulating blood. Shock often occurs as the result of hemorrhage, infection, or a combination of the two; but if not recognized early, shock becomes irreversible and rapidly fatal. Thus a need exists for an accurate indicator of the onset of shock so that corrective measures can be taken.

One important measure of the onset of shock is a reduction in blood pressure. Blood pressure is defined as the pressure exerted by the blood within the arteries. The two pressures of interest, systolic and diastolic, are the maximum and minimum pressures exerted on the walls of the arteries by the pulsatile pumping of the heart.

The primary method for measuring blood pressure is the sphygmomanometer which is a cuff placed around the upper arm. The cuff method is undesirable for continuous monitoring of blood pressure because the repeated inflation of the cuff disturbs the patient.

A method of monitoring blood pressure on a continuous basis is needed for bed patients. The method should not significantly disturb the patient. The pressure range of interest is 0-200 mm Hg and a sensitivity of 5-10 mm Hg is required. An invasive technique (i.e., one which punctures the skin) is considered undesirable.

A computer search of the NASA document file was made as the first step toward finding a solution to this problem. Although the search revealed a number of interesting documents, no adequate solution was found. However, the search revealed that Ames Research Center had conducted much of NASA's research in blood pressure measurement. During a trip to Ames Research Center, the Team discussed the problem with Mr. Joseph R. Smith who suggested that an alternate approach would be to use the oximeter developed by ARC for measuring blood oxygen content. This device was designed to clip onto the upper part of the ear and measure the oxygen content of the peripheral blood during various ground testing operations such as centrifuging. This approach was discussed with the problem originator and it was agreed that the approach was a useful one.

The oximeter, shown in Figure 17, operates by measuring the infrared absorption through the upper part of the ear by placing an infrared source and a detector on opposite sides of the ear.

The output of the meter is a measure of the oxygen in the blood of the ear. Since the constantly changing blood volume of the ear is caused by the blood pressure changes, the output of the oximeter is affected by changes in the blood pressure. Thus, the unit can be used to obtain a relative measure of blood pressure but not an absolute measure. The problem originator stated that the relative change in blood pressure was of major interest because it is this relative measure that is of importance in detecting the onset of shock. The

problem originator also stated that tests needed to be conducted to determine whether the peripheral blood pressure could be used as an adequate measure of the onset of shock.

The NASA ear oximeter is presently on loan for clinical trials at NCI. Studies of stability, sensitivity, etc. are being made in normal and hypotensive patients and an alarm circuit is being designed.



Figure 17. NASA ear oximeter.

PROBLEM NCI-4 *Controlled Rate of Freezing a Liquid*

Leukemia, a disease which kills about 15,000 Americans annually, is characterized by a proliferation of the tissue which forms white blood cells. Although the white cells in the blood can either increase, decrease, or remain constant in number, the bone marrow where the cells are formed will proliferate.

Treatment of leukemia involves killing the cancerous white blood cells in the blood and in the bone marrow using drugs or radiation. This process can cause loss of all bone marrow so that normal white cell production cannot occur.

When this loss of bone marrow occurs, white cells must be resupplied to the patient. For this purpose a bank or storage facility of white cells is required. This is impossible at present because adequate storage procedures are unavailable. Although red cells can be preserved by freezing, white cells are now destroyed by the existing freezing and thawing procedures. One important parameter in freezing white blood cells is believed to be the rate of freezing. Rate of freezing cannot at present be controlled because of the plateau in cooling rate when the latent heat is released at the freezing point.

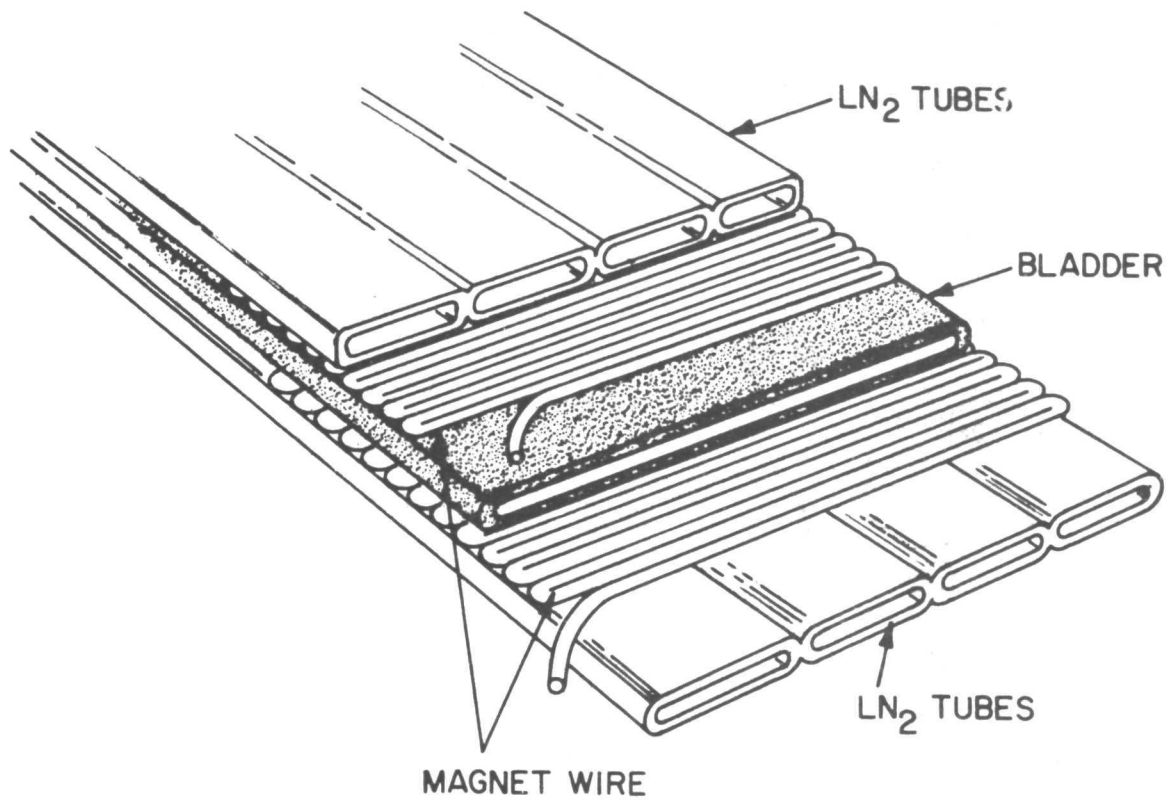

Figure 18. Controlled freezing unit.

The present method for freezing is a liquid nitrogen system which cools a secondary liquid which in turn cools the cells contained in a flat Teflon bag. To prevent contamination of the cells, it is desirable that any new technique utilize a Teflon container.

The basic requirement is to have a method of detecting the onset of freezing and then increasing the heat transfer rate during the release of latent heat so that a nearly constant rate of freezing can be maintained from room temperature to -50°C .

This problem was forwarded to the Jet Propulsion Laboratory where Mr. L. S. Doubt and Mr. W. Tener suggested the configuration shown in Figure 18. The cells are held in a Teflon bladder which is surrounded by a copper heating element and liquid nitrogen tubes. During the cooling cycle from room temperature to the freezing point, the heating coils control the cooling rate. At the freezing point, the heat is turned off and the latent heat of the cells is rapidly removed. Then the heat is turned on again to control the rate until -50°C is reached.

This proposed solution is being implemented by NASA personnel at Goddard Space Flight Center (GSFC). Coordination between NCI and GSFC research staff members will be closely maintained to insure that the final device will meet all medical and engineering requirements.

PROBLEM OF-2 *Bone Density Measurement*

A technique developed for measuring calcium loss in astronaut bones may prove useful in measuring calcium loss of cancer patients.

One of the many effects of a cancer is the secretion of a hormone which leaches calcium from the bone. This can produce lethal hypercalcemia. For example, 20 percent of lung cancer victims and 40 percent of breast cancer victims have hypercalcemia during the course of their diseases. Although some forms of hypercalcemia can be treated medically, the fundamental cause of its occurrence is unknown. In studies of experimental, tumor-bearing animals which secrete a hypercalcemia-producing substance, measurements of bone density would be useful in order to follow the progress of demineralization. Thus, a method of measuring bone density in experimental animals to be used in basic research on cancer is required.

At present, bone density is measured using the radiographic method in which an X-ray is made of the bone and the density of the X-ray film is used as a measure of the bone density. This method is unsuitable for repeated measurements because of the high doses of X-rays required. A method which does not involve X-rays would be desirable.

Although the technique will be used eventually on human beings, initially it will be used on rat tibia (3×0.5 cm). Changes in bone density as high as 50 percent are expected and the accuracy of detection should be

±5 percent. Preferably, the rat will not be sacrificed so that repeated measurements can be made over a fourteen-week period. Large numbers of animals bearing tumors can be utilized allowing for destructive measurement comparisons to be made.

A technique developed to measure astronaut bone density on the Skylab flights has been identified as applicable to this problem. Basically, this device (shown in Figure 19) measured the ultrasonic velocity through the bone which could be correlated with bone density.

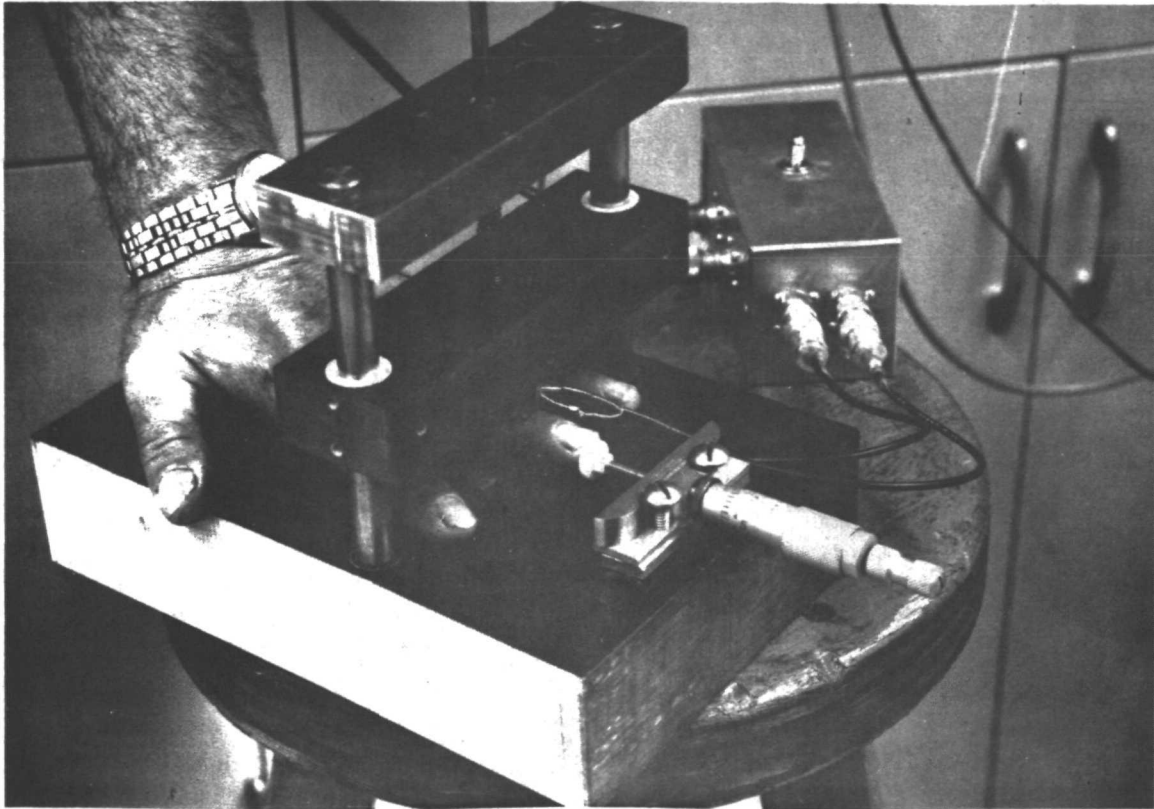

Figure 19. NASA bone densitometer.

Discussions with Dr. Ray Gause and Mr. Jim Hoop of MSFC revealed that this instrument was directly applicable to this particular problem. A complete description of the instrument was given to the problem originator, who has stated that he would like to obtain such a unit for his experimental studies. Plans are now being made to loan the MSFC bone densitometer to the Ochsner research group. Initial tests on the densitometer at the Baptist Hospital in Memphis have indicated that the device will be an excellent solution to this problem.

PROBLEM WF-103 *Liquid Crystal Sterilization*

Activities for this problem are discussed in the Technology Application Report in Section 2.1.

PROBLEM EU-5 *Sensors to Define the Position of Specific Parts of the Human Anatomy in Space During Normal Locomotion*

Activities for this problem are discussed in the Potential Technology Application Report in Section 2.2.

PROBLEM VAM-2 *Diagnosing Gait Abnormalities*

Activities for this problem are discussed in the Potential Technology Application Report in Section 2.2.

PROBLEM WWRC-7 *A Signalling (Nurse-Call) System for Multiple Sclerosis Patients*

Activities for this problem are discussed in the Potential Technology Application Report in Section 2.2.

PROBLEM WWRC-11 *A Valve to Permit Easy Emptying of Leg-Bag Urinals by Handicapped Patients*

Activities for this problem are discussed in the Potential Technology Application Report in Section 2.2.

PROBLEM WWRC-13 *A Remotely Controlled Device to Pick Up and Transport Single Sheets of Paper*

Activities for this problem are discussed in the Potential Technology Application Report in Section 2.2.

6.0 CONCLUSIONS AND RECOMMENDATIONS

During this reporting period the Team has accomplished a total of five applications and eight potential applications of aerospace technology to medicine. The major source of solutions for these problems has been direct contact with NASA field centers by Team personnel. During this reporting period 55 percent of the applications and potential applications of technology were solved by direct contact with the field centers and 8 percent were solved by information searching. In the reporting period for March, 1970, through March, 1971, direct contact with the field centers resulted in 68 percent of the solutions while information searches resulted in 21 percent of the solutions. Thus, it can be seen that the primary source of information is still direct contact with the field centers which demonstrates the need for continual close contact with all the NASA field centers.

Over the past several years the Team philosophy in problem solving has shifted from accepting large numbers of problems to accepting a fewer number of problems in order that more attention can be given to each individual problem. Our experience has shown that an adequate base of technology is available for solution of most problems. However, the diversity of technology available within the NASA system requires that significant effort be devoted to each individual problem, and if new and innovative uses of aerospace technology are to be developed, significant study must be made of each individual problem. Our philosophy is thus directed toward accepting fewer but higher quality problems and attempting to devote significant effort to each problem.

The philosophy of limiting the number of new problems enhances the image of the Application Team in the medical institution because of the increased probability of solution. If the physician is aware that an important effort will be devoted to his individual problem and that a good probability of solution exists, the Team is able to have access to more significant medical problems. This philosophy also allows the Team to operate at a specific medical institution for a longer period of time which helps to institutionalize the Application Team Program.

During the past nine months the number of user institutions has not changed. The Team recommends that activities now be expanded by establishing further interaction with the National Institutes of Health. Team experience with three of the National Institutes of Health has shown the NIH-originated problems to be of great medical significance.

Another advantage to the acceptance of problems from the NIH is the fact that an improved probability of implementation exists for any potential solution because of the availability of resources within the NIH and their contractors.

In a previous report, a discussion was presented on the difficulty of attempting to solve problems using sophisticated aerospace technology. In using highly sophisticated technology (for example, computer solutions), the interaction of medical and NASA personnel for a short time may not be sufficient to solve the problem. In these highly sophisticated problem areas, it becomes necessary for the medical researcher and the aerospace scientist to work together for a substantial period. This situation still exists and the Team again recommends that a format such as the summer fellowship program be established to allow these more lengthy interactions to occur. This action would increase the number of solutions with very high impact in the Application Team Program.

The availability of reengineering resources became a significant factor during this reporting period. This resource considerably increases the probability of solution implementation and has the potential for greatly increasing the impact of the program. It is anticipated that the concrete results of this new direction of the Application Team Program will become increasingly evident over the next six months.

Since the beginning of the Application Team Program in 1965, emphasis has been placed on solutions for medical problems originated by individual investigators. If the program is to increase its impact on the medical community, a broader scale utilization of individual technology applications must be accomplished. It has been recognized for some time that this broader scale utilization can only occur through the commercialization of individual technology applications. The Aerospace Technology Committee of the Association for the Advancement of Medical Instrumentation is now attempting to find ways to bridge the gap between the first new application of aerospace technology and the broad scale utilization that will occur when an individual device is manufactured. In bridging this gap, it may be of benefit to utilize the NASA reengineering capability to assure that several medical investigators are utilizing an individual technology application. Although the main thrust of reengineering is to determine feasibility of a specific technology application, it may prove beneficial to show that multiple applications exist when attempting to interest manufacturers in the individual technology applications. This must be done with considerable care to assure that the particular technology application has considerable impact. It appears that some incentive more than simply showing the existence of a solution of one individual problem is needed in order to interest manufacturers in a new product area.

Finally, the Team notes that one indication of the growing importance of the Application Team Program in the medical community is the increase in numbers of requests for invited presentations in the biomedical community. The number of presentations has increased significantly during the past year, and some of these presentations are reported in the appendixes of this report. The number of presentations and the reception of the individual presentations demonstrates that the Application Team Program

has grown significantly in maturity over the past several years and now shows significant promise of achieving the true potential of assuring that technology developed for the aerospace community is adequately used in other areas of major national interest.

APPENDIX A

PROJECT ACTIVITY SUMMARY

TECHNOLOGY APPLICATIONS ACCOMPLISHED

- EU-4 *A Simple Method of Obtaining Electrical Connection to
25-Micron Wire*
- NCI-8 *Elliptical Lenses*
- NHLI-5 *Bonding of Metal to Ceramic*
- WF-103 *Liquid Crystal Sterilization*
- WWRC-14 *An Improved Axillary Strap*

POTENTIAL TECHNOLOGY APPLICATIONS IDENTIFIED

- EU-5 *Sensors to Define the Position of Specific Parts of the
Human Anatomy in Space During Normal Locomotion*
- EU-12 *A Rapid Method of Applying EEG Electrodes*
- MISC-6 *Motor for Powering Prosthetic Unit*
- NHLI-1 *Intramyocardial Stress Measurement*
- VAM-2 *Diagnosing Gait Abnormalities*
- WWRC-7 *A Signalling (Nurse-Call) System for Multiple Sclerosis Patients*
- WWRC-11 *A Valve to Permit Easy Emptying of Leg-Bag Urinals by
Handicapped Patients*
- WWRC-13 *A Remotely Controlled Device to Pick Up and Transport Single
Sheets of Paper*

IMPACTS

- NCI-7 *Method of Fast Warming of a Frozen Liquid*
- WF-67 *A Filter to Separate Physiologic Data Occurring at Nominal
Heart Rates from Lower Frequency Data*
- WWRC-5 *An Improved Connector for Polyvinyl Tubing*

CURRENTLY ACTIVE PROBLEMS AS OF 31 DECEMBER 1971

| <u>Problem Number</u> | <u>Status Code*</u> | <u>Problem Title</u> |
|-----------------------|---------------------|--|
| CP-3 | E | <i>Automated Measurements from Coronary Angiograms</i> |
| CP-6 | D | <i>Utilization of Hodgkin-Huxley Equations for Determining the Propagation of Cardiac Action Potentials</i> |
| DU-31 | E | <i>Catheter-Mounted Pressure Transducer</i> |
| DU-48 | E | <i>Urine Flowmeter</i> |
| DU-72 | D | <i>Shadow Coating in Electron Microscopy</i> |
| DU-74 | E | <i>Testing of Neuropathic Patients</i> |
| DU-80 | B | <i>Measurement of Pleural Pressure</i> |
| DU-81 | C | <i>Detection of Blood Vessels in Bronchus</i> |
| DU-82 | C | <i>Maintaining Position of Telemetry Capsule in Digestive Tract</i> |
| DU-84 | D | <i>Liquid Radiation Shields</i> |
| EU-5 | E | <i>Sensors to Define the Position of Specific Parts of the Human Anatomy in Space During Normal Locomotion</i> |
| EU-7 | B | <i>Precise, Remote Micromanipulator Control</i> |
| EU-9 | B | <i>A Means of Uniquely Numbering Events Using One Channel of a Hard Copy Recorder</i> |
| EU-10 | D | <i>An Implantable, Four-Channel Telemetry System</i> |
| EU-12 | E | <i>A Rapid Method of Applying EEG Electrodes</i> |
| EU-13 | D | <i>A Sampling Manifold for Use with Multiple Gases</i> |
| EU-14 | D | <i>A Low Power DC-DC Converter</i> |
| EU-15 | B | <i>A Small Moisture Resistant Microphone</i> |
| EU-16 | B | <i>Means of Scrubbing Odors</i> |
| IRM-22 | E | <i>A Means of Tracking Eye Movements While Viewing Printed Matter, Geometric Forms, and Pictures</i> |
| IRM-23 | F | <i>A Respiration Alarm</i> |
| MISC-6 | E | <i>Motor for Powering Prosthetic Unit</i> |
| MISC-9 | B | <i>p_o₂ Telemetry Capsule</i> |
| MISC-11 | D | <i>Electrodes for Emergency Coronary Unit</i> |

*See explanation of status codes at end of listing.

| <u>Problem Number</u> | <u>Status Code</u> | <u>Problem Title</u> |
|-----------------------|--------------------|--|
| MISC-15 | B | <i>Fabricating Improved Membranes</i> |
| MISC-16 | B | <i>Cerebral Oxygen Measurement</i> |
| MISC-17 | B | <i>An Underwater Core Sampling Unit</i> |
| MUSC-1 | B | <i>Accurate, Inexpensive Method to Weigh Patients on Hemodialysis</i> |
| MUSC-2 | B | <i>A Rate-Sensitive Clutch to Decelerate Falling Patients</i> |
| MUSC-3 | B | <i>A Rapid Means of Sensing the Onset of Shock</i> |
| MUSC-4 | B | <i>Signal Conditioning Circuitry</i> |
| MUSC-5 | D | <i>Means of Controlling Infusion Pressure</i> |
| MUSC-6 | D | <i>Improved Method of Stabilizing a Respirator Tube in the Trachea</i> |
| MUSC-7 | D | <i>Automatic Recording of Time on Magnetic Tape</i> |
| MUSC-8 | D | <i>An Accurate Method to Control the Temperature of Air Beds</i> |
| MUSC-9 | B | <i>An Omnidirectional Microphone for Intensive Care Units</i> |
| NCI-3 | F | <i>Blood Pressure Measurement</i> |
| NCI-4 | E | <i>Controlled Rate of Freezing A Liquid</i> |
| NCI-9 | E | <i>Improved Emulsion for Autoradiography</i> |
| NCI-10 | E | <i>Scanning Tumors in Small Animals with Gallium-67</i> |
| NCI-12 | D | <i>New or Improved Methods of Detecting Breast Cancer</i> |
| NEHSC-1 | B | <i>Miniature Telemetry</i> |
| NEHSC-2 | B | <i>A Means of Characterizing Seizures in Laboratory Animals</i> |
| NEHSC-3 | B | <i>A Means of Determining the Quantity and Size of Cell Colonies in a Transparent Gel</i> |
| NHLI-1 | E | <i>Intramyocardial Stress Measurement</i> |
| NHLI-2 | D | <i>Enhancement of the Efficiency of Transfer of Oxygen through the Boundary Layer in Flowing Blood</i> |
| NHLI-5 | F | <i>Bonding of Metal to Ceramic</i> |
| OF-1 | E | <i>Blood Embolism Detection</i> |
| OF-2 | E | <i>Bone Density Measurement</i> |
| TU-3 | E | <i>Lung Sound Detection</i> |
| TU-9 | E | <i>Human Voice Analysis</i> |
| TU-10 | E | <i>Quantization of Heart Tissue Hardness</i> |
| TU-20 | D | <i>Cell Area Measurement</i> |
| TU-22 | E | <i>X-Ray Microplanigraph</i> |

| <u>PROBLEM NUMBER</u> | <u>PROBLEM STATUS</u> | <u>PROBLEM TITLE</u> |
|-----------------------|-----------------------|--|
| TU-25 | B | <i>Blood Damage Measurement</i> |
| TU-26 | B | <i>Water Purification</i> |
| UNC-60 | B | <i>Counting Exposed Points on Autoradiographs</i> |
| UNC-61 | D | <i>Pen Force Measurement</i> |
| VAM-1 | D | <i>Passive Stress Measurement</i> |
| VAM-2 | E | <i>Diagnosing Gait Abnormalities</i> |
| VAM-4 | D | <i>Microanalysis of Hormone Levels in Blood</i> |
| VAM-5 | B | <i>Safety Mechanism for Patients Medicines</i> |
| VAM-6 | D | <i>Negative Pressure Chamber</i> |
| VAM-7 | B | <i>Bacteria Detection Using Fluorescent Labelling</i> |
| VAM-8 | D | <i>Impedance Cardiographic System for Infants</i> |
| WF-56 | E | <i>An Improved Fluid Pressure Calibration System</i> |
| WF-89 | E | <i>Animal Restraints for Primates</i> |
| WF-96 | D | <i>Method of Determining the Time of Transit of a Time-Varying Waveform between Two Points in Space</i> |
| WF-104 | D | <i>Encapsulation Techniques for Long-Term Implantation of Electronic Components</i> |
| WF-107 | B | <i>An Inexpensive Method of Monitoring Respiration in Anesthetized Primates Being Ventilated by Mechanical Respirators</i> |
| WWRC-7 | E | <i>A Signalling (Nurse-Call) System for Multiple Sclerosis Patients</i> |
| WWRC-8 | D | <i>A Waterproof Sealant for Rubber-Coated Nylon Stretcher Pads</i> |
| WWRC-10 | D | <i>A Means of Reducing Friction in Upper Extremity Prostheses Control Mechanisms</i> |
| WWRC-11 | E | <i>A Valve to Permit Easy Emptying of Leg-Bag Urinals by Handicapped Patients</i> |
| WWRC-13 | E | <i>A Remotely Controlled Device to Pick Up and Transport Single Sheets of Paper</i> |
| WWRC-15 | B | <i>An Improved Valve for Total Contact Lower Extremity Prostheses</i> |
| WWRC-16 | D | <i>Improved Wheelchair Cushions for Prevention of Decubitous Ulcers</i> |

STATUS CODE DEFINITIONS

A. Problem Definition

Problem definition includes the identification of specific technology-related problems through discussions with biomedical investigators and the preparation of functional descriptions of problems using nondisciplinary terminology.

B. Information Searching

Information relevant to a solution is being sought by computer and/or manual information searching.

C. Problem Abstract Dissemination

An information search has revealed no potential solutions, and a problem abstract is being circulated to individual scientists and engineers at NASA Centers and contractor facilities to solicit suggestions.

D. Evaluation

Potentially useful information or technology has been identified and is being evaluated by the Team and/or the problem originator.

E. Potential Technology Application

Information or technology has been evaluated and found to be of potential value but has not been applied.

F. Followup Activity

A technology application has been accomplished, but further activity (e.g., documentation, obtaining experimental validation of utility, continuing modification, etc.) is required.

APPENDIX B

DESCRIPTION OF CURRENTLY ACTIVE PROBLEMS (CATEGORIZED
BY HEALTH AREAS)

(This description does not include those active problems previously discussed in Section 2 as technology applications, potential technology applications, and impacts.)

REHABILITATION MEDICINE

PROBLEM DU-74 *Testing of Neuropathic Patients*

A system designed to measure pilot performance has been adapted for the study of neuromuscular disorders.

Many people suffer neuromuscular disorders which result in the loss or impairment of muscular control. The cause of these disorders is damage to the nervous system which controls the musculature. One symptom of this disorder is uncontrollable contraction and relaxation of muscles.

Modern therapeutic treatment allows many thousands of patients to improve the degree to which they can exercise voluntary control over their muscles and, therefore, to assume a more active and useful role in society. Therapeutic treatment, however, is presently hampered by the difficulty of measuring the improvement that individual patients make during the course of therapy. As an example of a currently employed technique for measuring a patient's progress, the patient is presented with a drawing of a thin-lined geometrical pattern and is asked to trace the pattern with a pencil. From this experiment, one can make a subjective judgment regarding the degree to which a patient is able to control the movement of his hand. A more quantitative measurement of a patient's progress would lead to refined therapeutic techniques which, in turn, should bring about more rapid and more complete recovery for the many patients suffering from neuromuscular disorders.

In the design of highly reliable aircraft and space systems which are to be operated under direct manual control, the problem of the man-machine interface becomes critical. Scientists at NASA's Langley Research Center have been working for several years on the problems of designing flight vehicles which are well suited for control by a human operator. Of major importance is the understanding of the motor and perceptual characteristics of the human pilot. To measure pilot characteristics such as limb controllability, response time, rate of movement, etc., LRC researchers developed a variety of tests and testing apparatuses. This research resulted in a mathematical model of the human pilot.

The Team learned of this research at Langley and arranged a visit to talk with two of the pioneers in pilot modeling. Upon discussing this problem with the Langley researchers, it became evident that the tests they had devised to determine pilot characteristics had much in common with the requirements for testing patients with motor disorders. The Team was given a demonstration of a tracking task which was employed at LRC. In this case, aircraft pilots

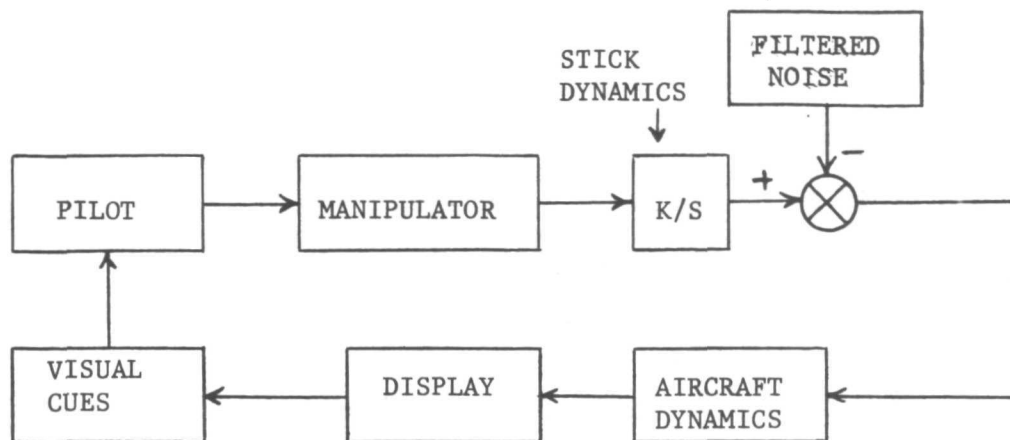

Figure 20. Single axis LRC tracking task block diagram.

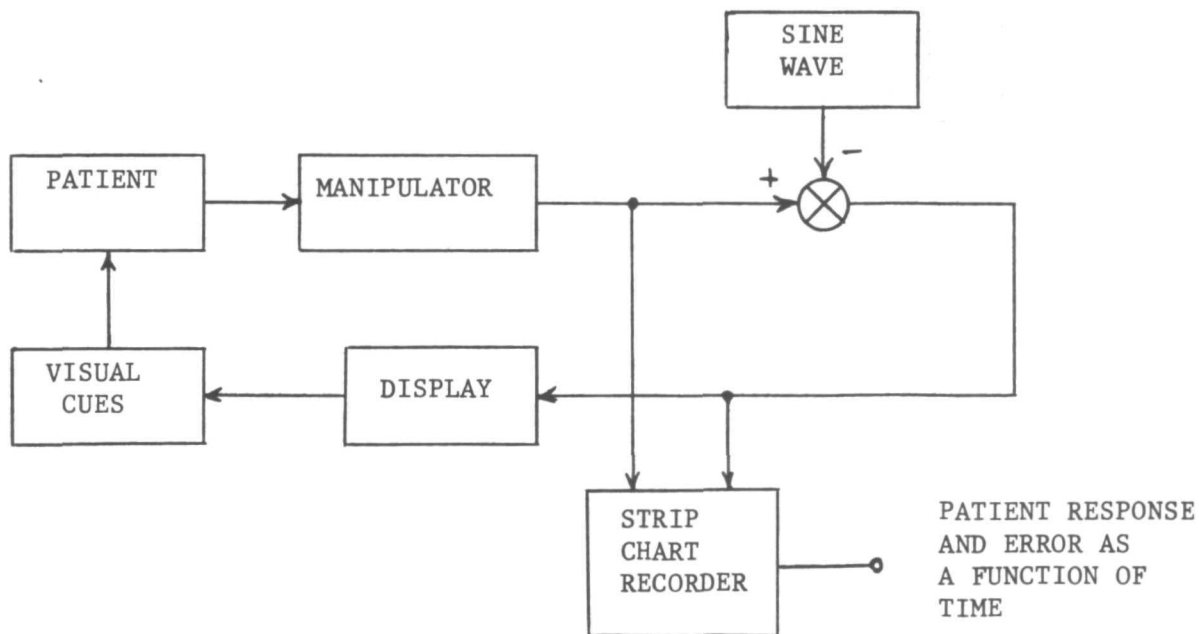

Figure 21. Block diagram of single axis track task for testing neuropathic patients.

were required to track a random disturbance by positioning a joystick in a manner which maintains an oscilloscope trace in the zero position. With this configuration, it was possible to record both pilot response and instantaneous error in tracking random disturbance. Included in the task were model stick and aircraft dynamics. This configuration is illustrated in Figure 18 for a single axis tracking task. The Langley researchers suggested that the stick and aircraft dynamics be removed from the tasks in order to acquire a better measurement of the motor performance of neuromuscular patients. The LRC tracking task with the suggested modifications as shown in Figure 19 has been evaluated by the problem originator. The problem originator is presently preparing a proposal to solicit funds for implementing the system.

PROBLEM EU-7 *Precise, Remote Micromanipulator Control*

Field mapping of potentials using microelectrodes is a technique employed in neurophysiological research. In this technique a micromanipulator is used to position microelectrodes in X, Y, and Z directions. Positioning must be accurate to ± 5 microns in the X and Y directions and ± 1 micron in the Z direction. Manual positioning of the micromanipulator is thus a time-consuming and laborious process in order to provide the field mapping required. A means of automatically positioning the micromanipulator in X and Y directions and then stepping in the Z direction in steps of one micron under remote control is desired. Such control of the micromanipulator would greatly facilitate the gathering of these data. Basically, X-Y control with a micromanipulator may be accomplished separately from the Z control. Once the X-Y position is achieved, the Z direction must then be stepped in one-micron increments. The micromanipulator employs three orthogonal lead screws to control X, Y, and Z movement. One complete revolution of the lead screw produces a linear motion of 500 microns. A search of the NASA literature failed to retrieve any direct solutions to this problem. A search of NASA tech briefs revealed two tech briefs which are peripherally related to this application. These tech briefs have been supplied to the researcher. If, in the researcher's evaluation, the techniques described in the tech briefs are applicable to this problem, then contact will be made with researchers at the NASA Research Center from which the tech briefs originated for further information.

PROBLEM EU-9 *A Means of Uniquely Numbering Events Using One Channel of a Hard Copy Recorder*

At the Rehabilitation Research and Training Center, most research projects and studies in neurophysiology employ computerized data processing techniques. In many of the clinical tests, however, the data is recorded on hard copy using a multichannel recorder because relatively small amounts of data are involved. During these tests, EMG signals are recorded as the patient follows a specified protocol of movements. The EMG signals are thus recorded sequentially. In order to analyze these signals, it is absolutely necessary that any given signal be uniquely identified with the precise motion of the individual. Extraneous signals are produced by the patient between steps in the protocol; not infre-

quently, patients do not perform the movement properly and it must be repeated. This leads to confusion and difficulty in correctly identifying the EMG signal with the particular step in the protocol which produced it. A simple means of uniquely indicating on one channel of a hard copy recorder, the number of the step in the protocol being accomplished by the patient, as well as the beginning and ending of the step is desired. Entry of the data into the recorder should be easily accomplished by the researcher or clinician--preferably by depressing a pushbutton. Up to 100 steps may be required in the protocol, although most procedures are considerably shorter in length. A computer search of the aerospace literature has been conducted, and the researcher is presently evaluating the material contained in this speech.

PROBLEM EU-10 *An Implantable, Four-Channel Telemetry System*

As part of a continuing research program in neurophysiology at the Rehabilitation Research and Training Center, a number of large primates (apes) are to be instrumented so as to obtain records of the EMG signals from specific muscles during free-ranging activities in a pen. No restriction on the motion of the apes, other than the geographic bounds of the pen, are desired; therefore, a telemetry system is required. Implantable units are desired although some compromise may be possible in this area. Four data channels are required, and the signals to be transmitted vary from 50 microvolts to 2 millivolts within a frequency spectrum of 10-200 Hz. Linear output from the telemeter is desirable. A total battery life of 24 hours is adequate. Remote activation and deactivation of the transmitter is desired so that data can be collected for one or two hours a day over a nominal ten-day period. It is expected that the receiver and remote control unit can be placed 10-15 feet from the animals so that a range of 15 feet is required. Information on multichannel implantable telemetry systems developed at the Ames Research Center has been forwarded to the researcher. It is felt that these units meet all the specifications of this problem. The researcher is currently evaluating the Ames-developed telemetry systems to determine the feasibility of fabricating units for use in this research program.

PROBLEM IRM-22 *A Means of Tracking Eye Movements While Viewing Printed Matter, Geometric Forms, and Pictures*

Visual scanning difficulties in one side of the visual field are often encountered in the hemiplegic patient. These scanning difficulties interfere in the processing of visual information. They prevent the hemiplegic from singling out pertinent cues that are involved in visual-perception tasks. Some tend to ignore visual stimuli located on their impaired side; others render false information on the impaired side, and as a result, spoil the information on their intact side; while still others compensate by turning their heads. These difficulties affect the cognitive functioning of the hemiplegic and have consequences for activities in his daily life--such as reading, dressing, and manipulation of his wheelchair. There is also a relationship between scanning difficulties and accidents in the hemiplegic population. The researcher wishes to explore the movements of the eye while the patient is viewing printed matter,

geometric forms, and pictures. This information will permit comparison of hemiplegic patients with normals and hopefully will permit the characterization of eye movements. This information could then be employed in appropriate individual programs of retraining to eliminate or reduce the visual difficulties of the hemiplegic.

An oculometer developed at the NASA Electronics Research Center has all the technical capability required to solve this problem. Unfortunately, its cost is quite high, and efforts to obtain a unit on a trial basis have been unsuccessful. Efforts are continuing to be made, however, to obtain such a unit for the researcher's use. Another unit has been identified which potentially could be of value to the solution of this problem. This unit is an automated visual sensitivity tester developed at the NASA Ames Research Center. Detailed information on the automated sensitivity tester has been obtained from the Ames Research Center and is being evaluated by the medical researcher.

PROBLEM UNC-61 *Pen Force Measurement*

Drug abuse in the United States is now one of our major societal problems. In order to combat this problem, research is under way at several institutions to understand more about drug effects on humans and to find better methods of rehabilitating habitual drug users. Verbal behavior (e.g., coherence and intelligibility of speech and text) may provide a key to understanding more about the effects of drugs as well as the underlying causes of drug abuse in particular individuals. The problem originator plans to study verbal behavior by having a subject write a response to questions that appear before him automatically. The psychologist conducting the test would determine future questions by the subject's response to the present question. The subject's response is not only what he says but how he writes it. For example, hesitancy in response might indicate reluctance to answer the question. A question which arouses a sense of anger (perhaps "Do you like cops?") might result in more force exerted on the writing paper. A means of measuring force exerted by a pen on the paper while writing would provide this auxiliary information which could aid psychologists in discovering the underlying problems in patients that have turned to drugs. This, in turn, would lead to more appropriate therapy to promote patient rehabilitation.

Several suggestions were received from NASA's Langley Research Center and are under evaluation by the problem originator.

PROBLEM VAM-1 *Passive Stress Measurement*

Thousands of Americans suffer loss or impairment of their limb functions. Artificial limbs offer a degree of rehabilitation for many of these persons who are then able to resume some of their normal activities. A problem which is impeding the development of improved limbs is the lack of knowledge as to why certain designs lead to more complete rehabilitation than others. To resolve this problem and, therefore, to establish better design criteria for artificial limbs, a researcher wishes to implant a stress sensor within certain muscle and

fatty tissue of the knee. The information derived by this approach should define those stress conditions that are brought about by various artificial limb configurations and identify those stress conditions that are compatible with more complete rehabilitation.

An implantable, passive stress measurement system, i.e., one which accepts power from a remote location and reradiates it with a modulation determined by the applied stress, would provide a means of extracting stress parameters from patients without interfering with their limb movements. Of primary concern is that the device be completely implantable and capable of periodic use over a 3- to 5-year period.

No solution to this problem has been found. Hewlett-Packard plans to market a passive stress measuring system within a year but the applicability of this device is questionable. The Team is searching for an alternate solution to the problem.

PROBLEM WWRC-10 *A Means of Reducing Friction in Upper Extremity Prostheses Control Mechanisms*

Many currently used upper extremity prostheses rely upon cables to perform the actual control function. Generally speaking, a cable harness arrangement is used to permit operation of the hook so as to obtain pinch. One of the difficulties encountered with these types of prostheses is the fact that a significant amount of effort is required to operate them. In examining the causes of this effort which is required to operate the unit, it has been determined that as much as 40 percent of the energy is consumed as friction loss in the cabling mechanism. An effective means of reducing this friction loss to as low a value as possible is desired. The Team is continuing to investigate this problem and search for solutions.

PROBLEM WWRC-15 *An Improved Valve for Total Contact Lower Extremity Prostheses*

Total contact prostheses depend in part on suction and friction to hold them in place. The limb to which a prosthesis is attached cannot be readily cooled (as the normally exposed skin is) so that perspiration becomes a problem. In the leg prosthesis, perspiration pools in the lower part of the socket causing improper fit and loosening of the prosthesis. The wearer must occasionally remove this collected perspiration. This is accomplished by opening a valve in the base of the socket while placing his weight on the prosthesis, thus forcing the perspiration from the socket. The valve is then released to close it and maintain suction. The perspiration wets the trousers or other clothing the patient is wearing on the legs. This is unsightly and embarrassing to the patient. The present valve is so constructed that drainage tubes cannot be attached because the patient must have access to the valve in order to operate it. A different kind of valve is required so that a drainage tube can be attached without interfering with operation of the valve. Dead air space between the prosthesis socket and the valve must be held to a minimum. Operation

of the valve must be accomplished with the drainage tube intact. No useful information has yet been identified that is applicable to this problem.

PROBLEM WWRC-16 *Improved Wheelchair Cushions for Prevention of Decubitous Ulcers*

The Woodrow Wilson Rehabilitation Center, as one of the larger elements of the Virginia Vocational Rehabilitation Program, has enrolled in its educational and training programs large numbers of patients who are paralyzed to the extent that they must spend their awake hours in a wheelchair. The continual sitting in such wheelchairs leads to soreness and eventual ulceration causing significant difficulties with this particular population. In addition, many of these patients have lost sensory function and cannot determine when pressure points are developing. The result is that they do not shift position because they are not aware of their difficulties and this leads to ulceration. The fundamental requirement of the suspension technique or cushioning material is that it should eliminate the presence of pressure points which normally occur when most conventional cushions and seats are used.

The NASA-developed Temperfoam material has been suggested to the researcher for his evaluation.

ARTIFICIAL ORGANS

PROBLEM EU-14 *A Low Power DC-DC Converter*

The researcher is interested in the possibility of using biologically powered fuel cells as power sources for various components required for implantation in the body--for example, as pacemakers. Pacemakers as now employed are battery powered, and periodic operations are required in order to replace the battery. Usually battery replacement is required about once a year. The development of biologically powered fuel cells would permit long term implantation of devices requiring power without the necessity of additional operations to replace batteries. The researcher has developed a biologically powered fuel cell which shows promise as a power source for this application. The output of the fuel cell, however, is extremely low voltage making it difficult to use as a power source for conventional devices. The output of the fuel cell is approximately 1/2 volt DC. It is felt that the voltage must be stepped up to about 5 volts DC to become useful with currently available components. A DC-DC converter is required to convert the low level DC output of the fuel cell to the nominal 5 volt output desired.

The voltage output of the fuel cells is 0.5 volts DC, and the total output of the cell is approximately 200 microwatts. The DC-DC converter should change this 0.5 volt DC level to a 5.0 volt output at around 80% efficiency. This would mean an output power of approximately 160 microwatts. Since the converter must be implanted within the body, small size is also required. The maximum useful size DC-DC converter is approximately 1/2 in. x 1 in. x 1 in.

The Wilmore Electronics Company has developed a number of DC-DC converters for NASA under contract. Dr. Towson Moore of Wilmore was contacted and the feasibility of solving this problem using the technology they have developed was discussed. There is some promise that a suitable solution can be effected. Several trade-offs are involved, however. Evaluation of these trade-offs is underway to determine if an acceptable compromise can be reached.

PROBLEM NHLI-2 *Enhancement of the Efficiency of Transfer of Oxygen through the Boundary Layer in Flowing Blood*

Heart disease is the major cause of death in the United States. Although much advancement has been made in the treatment of diseased hearts, it is unlikely that complete rehabilitation will be possible unless the patient's heart is returned to full health. Artificial heart systems are being developed as one of the possible future therapeutic methods of restoring circulation. One of the critical technology areas in the artificial heart program is concerned with the power sources to be used to operate the various devices that are necessary to perform the heart function. A totally implanted biological fuel cell operating on reactants (chiefly oxygen) derived from the blood stream, if feasible, would be a nearly ideal power source for operating an implanted artificial heart. Basically, the biological fuel cell will employ membrane-coated electrodes over which arterial blood will flow, transferring oxygen from the blood to the electrode by diffusion. The efficiency of the transfer of oxygen through the boundary layer in flowing blood must be high in order to generate sufficient power to carry out the function of the heart. A method of increasing the rate of diffusion of oxygen through the boundary layer of the blood adjacent to the membrane coated electrode is needed.

A literature search failed to produce a solution to this problem. A problem statement is being prepared for dissemination to the NASA field centers.

ORGAN ASSIST DEVICES

PROBLEM IRM-23 *A Respiration Alarm*

NASA expertise in monitoring air flows has been applied to monitor flow in respirators at the Goldwater Memorial Hospital of the New York University Medical Center, one of the largest respiratory centers in the United States. Users of these respirators are permanently disabled; e.g., stroke victims, paralysis victims, and others permanently unable to respire themselves as a result of accident or disease. This means that the respirators must be used on the patients continuously. The respirators have battery-operated alarms connected to their mechanisms which function when the respirator becomes disabled. The alarms are not foolproof, however, because the alarm system itself is subject to failure; circuit failures can and do occur. In addition, the batteries that power the alarm system can become depleted without the knowledge of the nurse, and maintenance personnel must be relied on to insure that the batteries are always adequate. Consequently, the nurses do not fully

trust the alarm system. This results in closer surveillance by the nurses and, correspondingly, requires more of their time. There have been reported cases in which patients have died when respirators with faulty alarms became inoperative before medical personnel became aware of the situation. As a result, a separate alarm system is desired, independent of the respirator alarm, which can sense when a patient is not being respired. It is desired that the alarm be attached to the patient and monitor some parameter that is a direct index of whether the patient is being respired or not. Detection of a mechanical parameter, such as change in volume of the chest with respiration, would be acceptable.

The alarm must be reliable. It must be sensitive enough to detect loss of respiration, but not so sensitive as to give frequent false alarms. If frequent false alarms occur, the unit will be turned off or ignored and will serve no useful purpose. Attachments to the patient must not be so bulky as to cause patient discomfort. In summary, simplicity, reliability, and low false alarm rate are primary requirements.

NASA's Ames Research Center has developed a thermistor alarm system for determining respirator failure or for monitoring breathing rate. This technique depends upon the rise in temperature of the inspired air when it is passed into the lungs and held there. The temperature rise is sensed by means of a thermistor placed in the expired airstream from the lungs. The NASA technology, as originally developed, employed telemetric techniques permitting remote location of alarms. In this particular application, remote alarms were not required; therefore, the system could be simplified considerably by removing the telemetric portion of the system. Mr. Jack Pope designed and fabricated a hard-wire system with an audible alarm which could be used on the respirators available at the Goldwater Memorial Hospital. The system, shown in Figure 22, consists of a thermistor placed in the exhaust tube.

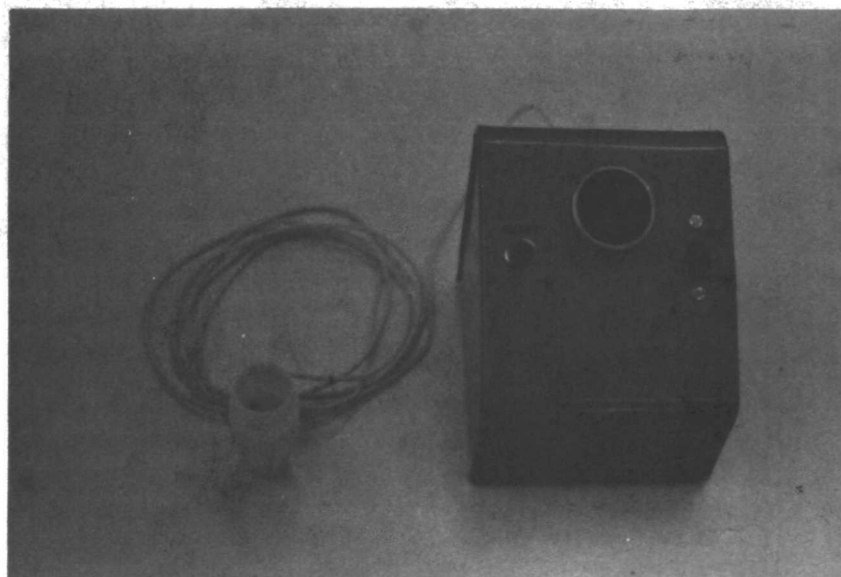

Figure 22. Respiration alarm.

The thermistor detects the thermal fluctuation of the air as the patient is respired. This thermistor is hard-wired to a signal processor and alarm circuit. Adjustments are provided for depth of respiration, and a delay is incorporated into the circuit which can be adjusted for individual requirements. When a failure is detected, an audible alarm is actuated.

This unit will permit one of the more seriously ill patients to be monitored for respiration failure on a long-term basis with significant confidence. This will eliminate much of the monitoring which is presently done by the nurse and will free her for other duties for which she is badly needed in the hospital. Favorable final evaluation is likely to result in a number of the units being constructed for use at the Goldwater Memorial Hospital on those patients who are critically ill and who must be maintained on respirators for long periods of time. If final evaluation of this technology is favorable, it is recommended that information on these techniques be disseminated to some of the major hospitals which maintain large numbers of patients on respirators; for example, an effective alarm system might find application in many of the VA hospitals across the United States.

PROBLEM MISC-15 *Fabricating Improved Membranes*

The artificial lung under development by the National Heart and Lung Institute is a temporary assist device which can be used to perform the respiratory function while the patient's lungs are being returned to health. Perhaps the most critical part of the artificial lung is the oxygenator. The oxygenator is a device for exchanging gases in red blood cells. It consists of a blood-gas interface separated by a thin membrane. When the patient's blood is brought in contact with the membrane, oxygen is transferred to the red blood cells as carbon dioxide leaves.

The membrane is made of a thin sheet of silicon rubber onto which a Dacron fabric is attached. The fabric gives mechanical strength to the membrane and serves to alter the conditions of blood flow causing turbulence which brings red blood cells in contact with the membrane. The quality of commercially available membranes does not permit the efficiency of gas exchange that is desired. Becton-Dickinson scientists are studying ways of fabricating more suitable membranes. There are three problems associated with the process of manufacturing the membranes: (1) trapped air bubbles, (2) particulate matter, and (3) gel particles. While some air bubbles and particulate matter are present in the silicon rubber sheet prior to attaching the Dacron fabric, these problems are made worse by the addition of the fabric. Methods of overcoming these problems are necessary in order to produce better quality oxygenators.

The Team has discussed this problem with persons at NASA's Lewis Research Center. It is felt that the quality of the membrane could be improved with more advanced fabrication techniques and a Lewis engineer is considering the problem.

PROBLEM MUSC-1 *Accurate, Inexpensive Method to Weigh Patients on Hemodialysis*

The patient with kidney failure can usually be classified in one of the following three categories: (1) chemicals are not cleared from the blood and only water is excreted by the kidneys; (2) the kidneys are not cleared of either water or toxins in the blood; (3) the kidneys clear some of both, but not an adequate amount. In a significant number of cases, inadequate amounts of water are removed from the patient by the kidneys. In these cases, an ultrafiltration method is required to remove the water. The method essentially involves an external shunt in which the patient's blood is passed through an external dialyzer machine and fed back to the patient. For the average patient, four or five quarts of water are removed by the dialyzer in one treatment. This is usually accomplished over a period of approximately six hours. In the hospital, special metabolic beds are employed which can accurately weigh the patient to small fractions of a pound. By observing the weight loss for the first hour or so during dialysis, the rate of water removal can be controlled to achieve the desired water loss in the period of time that it is desired to keep the patient on the dialysis machine. In addition, the nurses can periodically check the progress of dialysis by noting the patient's weight and can terminate dialysis when the proper amount of water loss has occurred. Control is more difficult in the home environment. First, the metabolic beds, which cost from \$1200 to \$5000 depending upon brand and complexity, are too expensive for normal home use, so the patient cannot monitor his rate of water loss. Since the objective of home dialysis is to make the patient as self-sufficient as possible, most home dialysis is done at night while the patient is sleeping. As a result, it is very important that the patient set up the dialysis rate so as not to exceed the desired amount of water loss during his sleeping period.

It is very important that the patient does not adjust the machine in such a fashion as to achieve a water gain, because this would mean that the menodialysis unit is adding water rather than extracting and could lead to serious difficulties. A method of weighing the patient in his own bed at home which is accurate to 1/4 pound would permit the patient to set up the dialysis procedure and monitor its progress for approximately an hour to determine whether or not he is dialyzing at the proper rate. Once a stable and acceptable rate of water loss has been achieved, the patient could sleep for the prescribed time. The use of such a weight-measuring device in the home would overcome many of the objections to home hemodialysis and would permit more people to be dialyzed in the home rather than in the hospital.

One method which has been attempted is the use of an air mattress connected to a sensitive manometer. This technique has not yielded accurate results, however, because of the changes in shape of the air mattress with position of the patient and the consequent loading changes that occur. From a practical standpoint, it appears that use of a conventional air mattress in this application would not permit the desired accuracy.

Basically, a device is needed which can weigh the loss of water achieved by a patient during hemodialysis. If placed directly under the patient, it must be comfortable enough for the patient to sleep on and would, no doubt,

be placed on the patient's bed. In this case, the unit would be required to weigh the patient alone, who might have a maximum weight of 200 pounds. A more reasonable approach might be to place the patient's bed on the weight-measuring device in such a fashion that the total weight of the bed and the patient is monitored. The bed can be assumed to weigh less than 200 pounds so that a maximum weight of 400 pounds is expected. Although in most applications, it is expected that the total weight would be significantly less than this, perhaps on the order of 300 pounds or possibly as low as 250 pounds. Accuracy of 1/4 pound is desired. Cost is an important factor in the widespread use of any product which might result for home use. It is felt that the maximum cost which could be tolerated in such a weight-measuring device is \$500. The lower the cost, the more likelihood of any widespread implementation. It is not necessary to continuously monitor the weight. It would be desirable to have a manual mode in which the patient could check his weight periodically as desired during the initial set-up to the dialysis unit. In addition, one can readily see that it would be extremely desirable if the patient's weight were automatically sampled approximately every hour and an alarm sounded when the proper weight loss has occurred.

A number of weighing techniques have been identified in the aerospace literature, but none has been acceptable within the constraints of this problem. Searching is continuing.

PROBLEM MUSC-3 *A Rapid Means of Sensing the Onset of Shock*

When the patient is put on a dialyzer, his blood pressure may be checked and found to be in a relative normal range, perhaps 120/80 mm Hg and the flow output of the artery in which the shunt is placed may be 400 cc per minute. In such a circumstance, the external pump which feeds the dialyzer coil may be set to pump approximately 200 cc of blood per minute. Generally speaking, the patient must remain on the dialyzer for approximately six hours to obtain the required loss of body fluids. If during this time the blood pressure of the patient drops drastically, say perhaps to 60/20 mm Hg, then the flow from the artery supplying blood to the dialyzer may drop to 180 cc per minute or less. When this occurs, the pump which is essentially a positive displacement device, will continue to pump at the 200 cc per minute rate. This means that the pump then begins to exert suction on the artery and actually begins to withdraw blood under suction from the patient. This negative pressure on the artery and withdrawal of blood can lead, if allowed to continue unchecked, to a shock condition. The patient can become unconscious, and if this occurs when he is asleep, he may never realize that he is in serious difficulty. In order to circumvent this possibility, patients who are considered to be remotely susceptible to a significant blood pressure drop must remain under surveillance by a nurse to insure that this condition does not occur. This means that many people who could otherwise have their dialysis performed away from the hospital must enter the hospital for dialysis and undergo the schedule disruption that such a visit entails as well as the additional expense involved in such circumstances.

There are several means of approaching the solution to this problem. For example, if it were possible to measure blood pressure on some periodic basis at the external arterial shunt, then an alarm could be sounded when the pressure dropped significantly. To be useful in this application, the blood pressure measuring technique must be one which does not require contact with the blood.

It is true that pressure is available outside the body in the external shunt, but in dialysis clotting is an extremely severe problem and it is not felt desirable to place any foreign body or any flow impediment in the arterial shunt which might cause turbulence and lead to clotting. In the first analysis the blood pressure measuring instrument could be used to sound an alarm and perhaps even turn the dialysis machine off as soon as blood pressure drops below a preset value. On the other hand, it can be seen that if a blood pressure measurement can be made available, frequently it might be even more desirable to use the blood pressure measurement as a control signal to vary the pumping rate of the external pump. For example, if the blood pressure goes down, the pumping rate could be decreased. A reliable means of accomplishing this would render home dialysis significantly safer than at the present time.

Basically, a means of measuring arterial blood pressure ahead of the external dialyzer pump is desired. The technique must be noninvasive and must not induce turbulence that might produce clotting. The measurement can be made outside the body provided it can be made on the plastic tube which runs directly from the patient's artery to the external dialyzer pump. It may be possible to approach the problem from an entirely different aspect. If the fundamental objective is to prevent the dialysis unit from inducing shock in the patient, any sensitive index which would accurately signal the onset of shock in the patient would be acceptable as an alarm system. Such an index must be sensitive enough to detect the onset of shock before nonreversible changes have taken place in the patient. If blood pressure measurements are employed in this application, it is felt that an accuracy of no greater than ± 10 mm of mercury is necessary.

The ear oximeter is being evaluated at the National Cancer Institute in connection with problem RTI/NCI-3, "Blood Pressure Measurement." If NCI evaluation proves favorable, the ear oximeter will be a solution to this problem.

DETECTION AND TREATMENT OF HEART DISEASE

PROBLEM CP-3 *Automated Measurement from Coronary Angiograms*

Techniques used to extract information from pictures of Mars are being used to obtain automated information on the performance of the human heart. Medical researchers at Duke University Medical Center developed a technique to determine myocardial contractility or functional character of the cardiac muscle. This technique should be particularly useful in determining the location

and extent of muscle function and as a means of determining effectiveness of surgical procedures designed to improve cardiac function by improving supply to the heart. The technique is thus suitable both pre- and post-operatively to determine coronary revascularization following treatment. The most appropriate surgical procedure or treatment to improve cardiac blood flow, and in turn cardiac function, can be determined by this technique which is based upon measurements taken from sequential coronary angiograms.

A coronary angiogram is an X-ray image of the heart taken after injection of a radiopaque dye into the coronary artery; this procedure makes the coronary artery and the arterial bifurcations (branching points) visible. The analysis technique above relies on measurements of dimensional changes of various portions of cardiac muscle during a cardiac cycle. These linear dimensional changes can be related directly to cardiac muscle function. The measurement of these dimensional changes is accomplished by measurement of position of specific arterial bifurcations recorded in coronary angiograms. Two separate angiograms are needed, a front-back view and a side view, to determine the location in three-dimensional space of a specified bifurcation. The distance between two bifurcations is a measure of the dimension of the intervening muscle at that instant of time.

At present this procedure is implemented manually. About 20 specific bifurcation points are recorded on the two X-ray views, and the positions of these points are then recorded over several complete cardiac cycles by angiograms exposed every 1/60 second. At 60 frames per second, two projections, 20 specified bifurcations and a total of several seconds of cineangiograms, the required determination of position changes and their time course is an exceedingly difficult and lengthy task. A reasonable method of automating this analysis of the angiograms is clearly needed if this technique of cardiac function analysis is to achieve clinical importance.

The automated reading of the 35 mm X-ray film strips should provide rapid and accurate information on the positions of specified arterial bifurcations. Accuracy should be compatible with image resolution on the order of 500 x 500 image resolution elements. It would be acceptable and probably desirable to manually identify (possibly by a light pen or similar technique) on the first film frame the specific bifurcation points to be used, and have the film reading system automatically follow the location of these points in the subsequent frames.

One approach would be to digitize each entire film frame and apply pattern recognition techniques. This is difficult and probably very inefficient for this problem, however, because at each frame the positions of the twenty or so desired points are already fairly well known from the analysis of the preceding frame. What is needed is a method of identifying and locating these points whose neighborhood values are already known.

The Team determined that the information of interest was at the Jet Propulsion Laboratory. Details of the JPL VICAR software program were given to the researcher and he decided that the enormity of this project required that he work directly at JPL for a short period. Thus, he applied for and

received a summer fellowship at JPL for 1970. During this period he learned the JPL image processing procedures, worked out his own algorithm, and determined that this approach could solve his problem. He then designed a modified system of image scanning and processing which was contracted by Dicom Corporation. This equipment has been delivered and is operational.

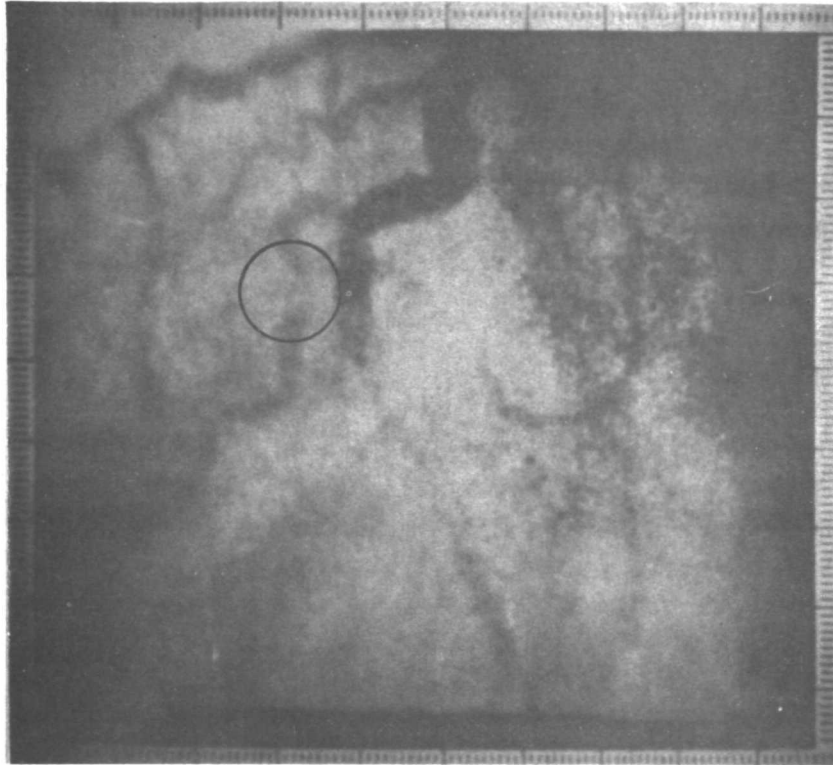

Figure 23. X-Ray of human heart enhanced by computer techniques.

This significant medical problem will be solved using a modification of the JPL image processing procedures. The equipment is operational, and the actual bifurcation identification has been accomplished over about ten frames of film. Figure 23 shows the result of using this technique to identify a region of reduced flow (the circled area in the figure). Additional use of this technique will enable the researcher to automatically record dimensional changes in the heart during a cardiac cycle.

PROBLEM CP-6 *Utilization of the Hodgkin-Huxley Equations for Determining the Propagation of Cardiac Action Potentials*

The present understanding and capabilities for the diagnosis of cardiac diseases such as myocardial infarction are limited by the lack of a precise quantitative description of the propagation of cardiac action potentials.

This quantitative description requires the solution of a nonlinear partial differential equation developed by Hodgkin and Huxley.

In 1952, Hodgkin and Huxley developed and tested a set of differential equations which describe the electrical properties of the excitable membrane of the squid nerve fiber. Since then the range of application has been extended in two ways. First, the original equations have been applied to a wider variety of phenomena in squid nerve, including the effects of temperature on the propagated action potential, the repetitive firing observed in low calcium concentrations, the prolonged action potentials produced by tetraethylammonium ions, and the hyperpolarizing responses observed in high potassium solutions. Second, the equations have been applied to other excitable tissues including myelinated nerve and cardiac muscle.

The work described in this problem statement is concerned with incorporating recent cardiac muscle data for the dependence of potassium conductivity into the Hodgkin-Huxley equations to study the propagation of cardiac action potentials. A solution to this basic research problem in cardiac physiology would have important clinical and diagnostic consequences.

Computer programs are needed to solve numerically the Hodgkin-Huxley equation for the case in which the sodium and potassium conductivities vary with position, time, and potential, to be used in basic research on the heart.

A computer program used for solving aerospace thermal problems is being evaluated as a potential solution to this problem. The program was obtained from NASA and evaluation on the problem originator's computer is underway.

PROBLEM MISC-11 *Electrodes for Emergency Coronary Unit*

The National Heart and Lung Institute is conducting a study at four major medical schools on the use of field packages for emergency coronary care. Three hundred thousand Americans die each year from heart attacks before reaching a hospital. A dramatic new concept is a portable field package for ambulance, police, and even patient use. This package contains two drugs in automatic syringes for use depending on the presence of (1) low heart rate or (2) erratic heart beat. A hand-held monitor determines which drug is needed. This monitor is simply an EKG monitor which determines rate and rhythm. The monitor works well except for the electrodes which must be applied immediately by untrained personnel. A new method of electrode attachment is required.

Several NASA electrode developments are being studied. The most promising is a dry electrode developed at Ames Research Center. The electrodes are on loan to the medical researcher for verification of their use in solving this significant medical problem.

PROBLEM VAM-8 *Impedance Cardiographic System for Infants*

In order to better diagnose and treat infants with congenital heart defects, researchers at the University of Miami are experimenting with a NASA-developed impedance cardiographic system. This system was developed to provide a simple, bloodless method of monitoring various parameters of cardiac function of adults without penetrating the skin. The system employs four circular flexible, metallic electrodes which are attached to the patient: two around the neck and two around the upper abdomen. University of Miami investigators wish to be able to use this system to measure cardiac parameters of infants; however, the neck electrodes that were designed for this system are inadequate for infants. It is necessary to find a means of employing the existing system with infants. If this system can be used with infants, the next step will be to determine whether useful measurements can be made on children with congenital heart defects.

The Team discussed the problem with Dr. Kubichek at the University of Minnesota who developed the NASA system. Dr. Kubichek made a suggestion that has not yet been tried by the problem originator.

PROBLEM WF-89 *Animal Restraints for Primates*

Arteriosclerosis is one of the significant contributors to coronary disease. The buildup of extraneous material within the arterial system causes a reduction in the size (diameter) of the arteries which carry life-giving oxygenated blood to the body tissues. This narrowing of the arteries can occur systemically or locally. When the arteries are narrowed, the blood flow to the tissues is reduced. If the blood flow is reduced sufficiently, the tissue being supplied by the artery dies. If the coronary arterial system, which supplies blood to the heart, is thus affected, the part of the heart tissue being supplied by that artery dies. This is called an infarct.

Narrowing of the arteries also increases the impedance of the arterial system. In an attempt to maintain blood supply to the tissue, the heart must work harder, thus imposing an additional workload on the heart. When constriction of the arteries occurs, there is an autoregulatory feedback mechanism which causes dilation of the arteries (vasodilation) in an attempt to compensate for reduction in blood supply to the tissue. In addition, this vasodilation can be accomplished by the administration of certain drugs (vasodilators). These drugs are frequently employed in treatment of arterial disease and associated problems where the objective is to improve the blood supply to the tissues. However, much is not understood about the mechanisms and effects of these drugs. This research program is designed to obtain this information on various vasodilators to permit their more effective use.

The investigator has accomplished extensive research to determine the effects of vasodilators on dogs using open chest methods. The next phase of the research program requires the use of rhesus monkeys using closed chest methods. The monkeys will be instrumented to measure blood flow, blood pressure, temperature, and ECG. The sensors will be implanted by open chest surgery,

and the animal will then be sewn up. The monkeys will be monitored for three to six months during the course of the study. During this period the monkeys must be restrained from activities which would potentially impair or damage the instrumentation. As a result of the Biosatellite Program and NASA research involving monkeys, it was felt by the researcher that animal restraint apparatus may have been built by NASA which would be potentially useful in this program.

Suitable animal restraint apparatus which can be employed on rhesus monkeys to prevent impairment or damage to instrumentation is required. The apparatus must permit maintenance of the monkeys for periods of three to six months.

Useful information resulted from contact with the Biosatellite Project Office at the Ames Research Center. Mr. Louis Polaski, as a result of a telephone contact with the Team, furnished complete information on the primate restraint system which has been developed at ARC for the Biosatellite Program. Specifically, complete engineering drawings of the primate restraint system were furnished to the researcher, and one of the animal restraint suits was mailed to the researcher by Mr. Charles A. Wilson, Biosatellite Project Manager, for inspection. This information and the cooperation from ARC, has been extremely useful to the researcher and has been applied as background and supporting information in the preparation of a grant request to the National Heart and Lung Institute for the establishment of an atherosclerosis research center at the Bowman Gray School of Medicine. This grant request covers a seven-year program in the amount of 3.8 million dollars. The particular portion of the program to which this information was applied is one facet of the experimental program comprising \$238,000 of the total grant request. It should be noted in assessing the impact reports for this reporting period that this particular grant, because of its size, has involved the use of information which has been supplied on two other problems (WF-90 and WF-91) as well. Therefore, the grant discussed in the impact reports on these problems is the same grant as the one referred to on this problem.

In addition, the primate restraint system information has been used in the preparation of a three-year grant request to the American Heart Association in the amount of \$42,000. This program involves the study of atherosclerosis and coronary adrenergic response. The experimental animals to be used in this particular research program are similar in size and weight to the animals used on the Biosatellite Program so that the Biosatellite restraint units can be easily modified for this research program.

PROBLEM WF-96 *Method of Determining the Time of Transit of a Time-Varying Waveform between Two Points in Space*

A parameter of significant interest in dye dilution techniques for determining blood volume in cardiac output is mean blood transit time. Using the dye dilution technique, dye is injected as a pulse into the blood vessel. Fairly sharp pulses are obtained; however, there is some delay in actually getting the dye into the flowing blood. In addition, it is known that the trailing

edge of the pulse decays slowly because of dye leakage from the injector and inadequate mixing. Nevertheless, a mean departure time for the pulse is assigned on the basis of when the dye is injected. The dye pulse is allowed to traverse a distance and is then monitored by detector. The detected dye peak is very diffuse with a long, slowly decaying trailing edge so that it is very difficult to estimate the mean departure time from the detector. Using these techniques, mean transit times two to three times greater than the theoretical mean transit time are obtained in current practice. A method of analyzing these pulses in order to more accurately assign a mean departure time from the injector and a mean departure time from the detector is desired.

A search of the aerospace literature has been conducted. Certain specialized signal analysis techniques developed at the NASA Marshall Space Flight Center appear to have application to this problem. In addition, research in fluid mechanics at North Carolina State University appropriate to this problem has been identified by the Team. Both the NASA signal analysis techniques and the approaches underway at the North Carolina State University are being evaluated for application to this problem.

PROBLEM WF-104 *Encapsulation Techniques for Long-Term Implantation of Electronic Components*

As a part of a long-term study program into atherosclerosis, the Bowman Gray School of Medicine is involved in a project using primates as experimental animals. Some animals will be fed normal diets while others will be fed atherogenic diets. One of the parameters which is to be monitored during these experiments is the blood flow through the coronary artery. The researcher has chosen an electromagnetic blood flowmeter as the instrument which he desires to use to monitor the blood flow. The manufacturer of the instrument has experienced difficulties with long-term implantation because of invasion of body fluids into the cable which connects from the probe tip to the connector outside the body of the animal. Using his present techniques for protecting these cables, the manufacturer has been unsuccessful in producing cables which will withstand more than several weeks of implantation. Fundamentally, the researcher is seeking improved encapsulation techniques which will permit the implantation of the electromagnetic blood flowmeter probe for periods of up to or exceeding six months in experimental animals without failure as a result of invasion of body fluids.

NASA SP-5094, "Implantable Biotelemetry Systems" outlines an encapsulation technique. This technique has been evaluated by the researcher and appears useful in this application. Efforts are now underway to locate sources for the materials required.

PROBLEM WF-107 *An Inexpensive Method of Monitoring Respiration in Anesthetized Primates Being Ventilated by Mechanical Respirators*

As part of a long-term study program into atherosclerosis, the Bowman Gray School of Medicine is involved in a project using primates as experimental

animals. Some animals will be fed normal diets while others will be fed atherogenic diets. During these studies it will be necessary to surgically implant a number of devices for monitoring various physiological parameters. During the surgical procedures, the primate will be anesthetized and respired using a positive displacement animal respirator. A trachial tube inserted into the animal's throat is used to connect the animal to the respirator. It is, of course, important that the animal be properly respired during these surgical procedures. Any interruption of the air flow supply to the animal will result in its death. These animals are specially prepared and represent a significant investment of funds and researcher time so that the loss of even one animal as a result of improper respiration is significant. In order to eliminate this possibility, a technique or method of monitoring the respiration of the animal is desired. A visual indication of the normal respiration of the animal is desired. For example, a meter could be used to provide a varying amplitude indication proportional to the respiration of the animal. For example, inspiration could represent a zero reading and expiration a positive reading so that the meter would fluctuate between zero and some positive reading during a normal inspiration/expiration cycle.

The respirator alarm system using telemetry techniques developed at the Ames Research Center appears useful in this application. The requirements in this problem, however, are significantly simpler so that complicated telemetric equipment is not necessary. In addition, the requirements for an alarm are not necessary. The fundamental requirement is for a meter reading to indicate inspiration and expiration. It is felt that a modification of the Ames circuitry can be accomplished to provide the required monitor at a very low cost.

DETECTION AND TREATMENT OF CANCER

PROBLEM NCI-9 *Improved Emulsion for Autoradiography*

Knowledge of photographic emulsions by a NASA researcher may improve the emulsions used in the autoradiographic study of cancer.

The study of cancer in experimental animals can be facilitated by labelling the cells with radioactive tritium. The tritium attaches itself to the DNA molecule, and the division of the tumor cell produces new labeled cells. A process called autoradiography detects a radioactive cell by placing a film of photographic emulsion over the cell and exposing the emulsion by the radioactivity. Existing emulsions require an exposure time on the order of months. If a much faster film can be developed, then this technique can be used clinically in following the progress of human cancers. This will provide a valuable new technique in the fight against human cancer.

A computer search of the literature on nuclear emulsions revealed that scientists at Goddard Space Flight Center had employed sounding rockets carrying nuclear emulsions to study the composition and

energy spectra of low energy cosmic rays. The TUO at GSFC was presented with this problem and suggested that the Team contact Dr. Jacob Trombka who was quite knowledgeable in this field. Dr. Trombka had experimented with several types of specifically prepared noncommercially available emulsions which will reduce the required exposure time. A Team member met with Dr. Trombka and he discussed these techniques at length. Arrangments have been made for Dr. Trombka to prepare an emulsicn for testing at NCI. These new emulsions offer the promise of improved information about cancerous cells.

PROBLEM NCI-10 *Scanning Tumors in Small Animals with Gallium-67*

An analytic technique developed for aerospace radiation detection is being considered for scanning tumors in animals.

Gallium-67, a radioactive isotope, possesses the special property of concentrating in various types of tumors when administered orally or intravenously to a patient. The mechanism of gallium uptake is not well understood; it is not known whether there is a direct binding of gallium in the tumor tissue or binding to some other agent which in turn is concentrated by the tumor. Whichever is the case, Gallium-67 appears mainly in viable rather than necrotic tumors. In addition, studies indicate that Gallium-67 is superior to other commonly employed tumor-scanning agents in absolute tumor concentration and in ratio of tumor to normal tissue concentration. These observations are possibly the most significant recent developments in nuclear medicine.

By administering Gallium-67 to a patient and scanning the body with an instrument which will detect the presence of radioactive substances, the location as well as the size of a tumor can be determined. Radiologists currently employ a variety of camera and scanning systems which are useful in locating tumors in humans but are relatively ineffective in studying the response of the tumor to therapy. In order to follow tumor growth on a day-to-day basis, a high resolution scanning system which is sensitive to Gallium-67 is needed. In particular, the scanning system should be suitable for scanning the entire bodies of small experimental animals. Such a system would offer a unique opportunity to study methods of inhibiting or retarding tumor growth.

A solution to this problem was proposed by Dr. R. T. Siegel, Director of the Space Radiation Effects Laboratory (SREL) which is operated by the College of William and Mary under support from Langley Research Center. Dr. Siegel's suggestion involves the use of lithium-drifted germanium detectors to analyze the gamma radiation emitted during the decay of Gallium-67. The excellent resolution of these detectors should lead to easy identification of the primary radiation and will greatly simplify the collimation procedure since scattered radiation will normally be degraded in energy and therefore easily separated from the primary radiation of interest. Investigators at SREL are preparing a three-dimensional computer-controlled scanning mechanism for use in radiobiological experiments. Dr. Siegel suggested that

this scanning mechanism might be used to control two lithium-drifted germanium detectors (operating at right angles to each other) to scan a tumorous source in three dimensions. A data acquisition system developed at SREL would move a small animal relative to the two radiation detectors and record the position of the animal at all times during the scanning procedure. The SREL system would then produce a map of the activity of the animal.

It appears that SREL is remarkably suited to solve the problem of scanning small animals. Dr. Siegel has demonstrated this system to NCI staff members using tumorous mice supplied to SREL by the National Cancer Institute. Detailed evaluation is expected to continue.

PROBLEM NCI-12 *New or Improved Methods of Detecting Breast Cancer*

Breast cancer is common: 5-6% of all women will at some time in their lives develop breast cancer. If cancers are discovered when they are still localized, the majority of them can be cured by surgery and radiotherapy. Provisions for earlier and more comprehensive treatment of patients with breast cancer require improved techniques for detecting malignant tissue during the initial stages of growth. Four techniques for detecting breast cancer are in use at present: physical examination, thermography, xerography, and mammography.

None of these techniques are sufficiently reliable. A combination of the methods provides an improved probability of detecting breast cancer; however, none of the methods provides conclusive results. Each of the methods has shortcomings. New or improved methods, techniques, or approaches for detecting breast cancer at an early stage are needed.

A problem statement was circulated to the NASA field centers and the Team received two suggestions which warrant additional investigation: (1) the use of liquid crystal thermography to obtain visualization of the temperature patterns of the breast with minimum effort and cost, and (2) vibrational methods for detecting tumors deep under the skin's surface. Feasibility studies are planned to evaluate both techniques.

PROBLEM TU-22 *X-Ray Microplanigraph*

An aerospace method used for analysis of printed circuit boards is being applied to obtain improved X-ray techniques of cancer detection.

Cancer is the second largest cause of death in this country and, according to a recent survey, is the disease most feared by the American people. The state of cancer treatment today is such that generally those cancers which are found early can be successfully treated. The easiest cancers to detect are those that are on the surface of the body, and those most difficult to detect are those

deep within the body. Thus, cancers arising deep within the body usually result in the death of the patient because detection of the cancer occurs too late.

It is desirable to develop an instrument capable of detecting tumors deep within the body. In addition, it is desirable to be able to determine whether or not the tumor is malignant or benign and the extent to which the tumor has spread. One common method of detecting tumors is by X-ray. Unfortunately, when the entire body is X-rayed, small tumors cannot be detected because the background level of signal of the X-ray is vastly increased by the thickness of the body. It would be highly desirable to develop a technique whereby X-rays could be made of lamina regions only. Thus, the X-rays could be made of thin laminae and smaller tumors could be detected. The basic problem then is to develop a method whereby X-rays of thin laminae can be made of a patient instead of the conventional X-ray technique.

The technique of making X-rays of thin laminae with high resolution is called X-ray microplanigraphy. This technique has been theoretically possible for many years. Recently, a development in NASA has significantly increased the possibility of developing such a technique. NASA developed such a technique for inspecting multilayer printed circuit boards layer by layer with a resolution of 0.001 inch. This technique has been well developed by a NASA contractor at Illinois Institute of Technology. Basically, it involves moving the X-ray source and detector in a particular geometrical arrangement in such a manner that only thin laminae are measured. The work was funded by MSFC, and the Team was apprised of the work through a computer search. The Team then contacted MSFC for additional information and was referred to the IIT investigator. The problem originator has discussed this technique in detail with the NASA contractor and has decided that this work is highly relevant to his investigation. An example of the use of the technique is shown in Figure 22.

The device has been implemented at the Tulane School of Medicine. The researcher indicates that tests to date indicate a significant improvement in tumor detection capability. A major study is now in progress to develop this device for clinical use.

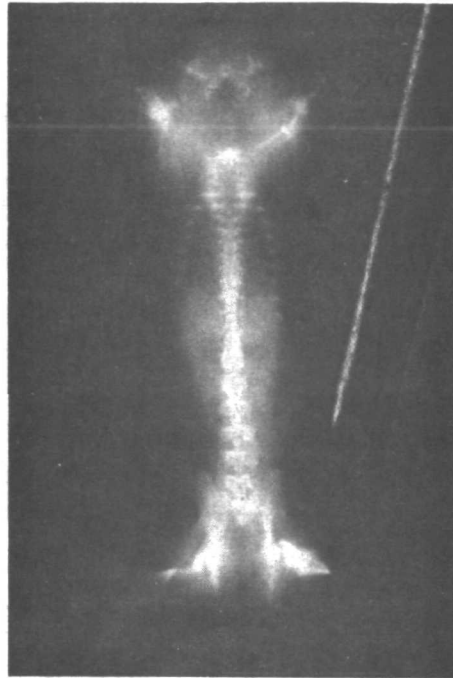

24a. Conventional X-ray image.

24b. X-ray planigraphic image.

Figure 24. Conventional and planigraphic X-ray images of a mouse.

HEALTH CARE COST REDUCTION

PROBLEM MUSC-2 *A Rate-Sensitive Clutch to Decelerate Falling Patients*

Patients in hospitals recovering from a wide variety of illnesses and surgery are required by their doctors to obtain exercise by walking. For these patients, however, walking can be a serious hazard, and they require help and supervision to prevent self-injury as a result of falling. In a study of the hospital at the Medical University of South Carolina, it has been determined that the help and supervision required while these patients are walking costs \$400 per day. Simple arithmetic reveals that approximately \$150,000 a year is expended in just walking patients or in supervision patients as they walk. The researcher is in the process of developing a system to permit patients to walk as prescribed by the doctor and to eliminate as far as possible supervision during the walking process. This means, of course, that the patient must be protected from falling. The fundamental approach has been to consider the possibility of a

track that is mounted to the ceiling of the patient's room from which a suspension rope or cable could be attached to a harness worn by the patient. The basic component required for successful implementation of such a system is a rate-sensitive clutch. The clutch must permit lengthening the suspension cable as the patient performs normal functions, such as arising from the bed, sitting in chairs, and moving around, in which the vertical displacement of the patient changes at a slow rate. On the other hand, if the patient should fall, it is desired that the clutch decelerate the patient by paying out the suspension cable at a decreasing rate so as to arrest the fall of the patient and gently lower him to the floor. Springs and elastic devices which recoil or rebound are not acceptable because they are potentially more hazardous than the fall itself. It is desirable that the clutch be adjustable to permit using it in an optimal fashion on a number of patients with a variety of body weights.

Quantitative specifications are difficult to assess for this particular problem. For normal patient movements it is felt that a vertical displacement is not likely to occur at a rate much greater than 8 inches per second. The clutch should permit the suspension cable to be played out at this rate with relatively little resistance. On the other hand, should the patient fall, it is desired that the clutch energize in such a fashion as to decelerate the patient as he falls toward the floor so that his impact velocity would not be greater than 6 - 8 inches per second. It is of course necessary that there be no recoil involved in the means of decelerating the patient such as might exist in springs or elastic bands. No useful technology has been identified. Searching is continuing.

PROBLEM WWRC-8 *A Waterproof Sealant for Rubber-Coated Nylon Stretcher Pads*

The Medical Service Division of the Woodrow Wilson Rehabilitation Center receives patients having spinal cord injuries. These injuries result in varying degrees of lower extremity paralysis and loss of function. Not infrequently these patients lose muscular control to the extent that they can no longer control their bowel movements. Stretchers have been modified by cutting out a square portion of the stretcher underneath the buttocks so that the patients can be given enemas while lying on the stretcher. Modification consists merely of cutting an appropriately sized square out of the stretcher and stretcher pad, and covering the edges thus exposed by sewing a rubberized nylon cloth in place. Unfortunately, this leaves a seam and needle-puncture holes. Because of these seams and punctures, the stretcher pad traps and absorbs urine, feces, etc., and it is very difficult to keep clean and odor-free. The result is that the pads must be discarded frequently, thus contributing to operating costs. A means of sealing the seams and needle punctures is desired in order to achieve a waterproof, easily cleanable surface. An alternative might be a flexible, water-proof adhesive which could

entirely eliminate the sewing now used to attach the covering over the exposed edges. As a result of searching procedures, the Team was able to recommend an aerospace silicon rubber adhesive which has potential application to the solution of this problem.

KIDNEY DISEASE DETECTION AND TREATMENT

PROBLEM DU-48 *Urine Flowmeter*

Diseases of the urinary system are a significant problem in medicine. One of the problem areas concerns the ureter, i.e., the tubes that connect each kidney to the bladder. Urine flow measurements in the ureter are being used in a research study to understand ureteral physiology. Improved flow measurement techniques also could be used in clinical studies of kidney, ureteral, and bladder diseases. All existing techniques for measuring flow in the ureter involve collecting samples of urine over definite intervals of time and calculating average flow rates. These average flow measurements are not satisfactory when the pulsatile nature of flow in the ureter is being studied. This pulsatile flow of urine is felt to be very important in obtaining a better understanding of ureteral physiology.

The requirement here is for a technique for measuring instantaneous rates of urine flow in the ureter. The transducer can be used either internally or externally. If an external transducer is used, the flow of urine can be diverted to a point outside the body using a catheter.

The flowmeter should measure transient urine flows of from 1 to 100 cc/min with an accuracy of $\pm 1\%$. Size of the flowmeter is not important because the flowmeter can be outside the body. A flowmeter using the principle of thermal distribution proposed for the Skylab flight program is being evaluated as a potential solution to this problem. The NASA contractor and the problem originator are discussing the possibilities of a joint effort.

REDUCTION OF INFANT MORTALITY

PROBLEM MUSC-4 *Signal Conditioning Circuitry*

Clinical personnel at the Medical University of South Carolina Hospital have indicated the need for a cardiometer which can be employed on very small children to permit obtaining the heart rate of these children periodically or as desired. It is not desired to continually monitor the heart rate of these children. Many immature children and very young children have extremely high heart rates--sometimes as high as 200 beats per minute. Many of the currently available inexpensive cardiometers will not measure

heart rates this high. Multirange units which will measure heart rates up to and above 200 beats per minute are relatively expensive. The Biomedical Engineering Department at the Medical University of South Carolina has been asked to provide an inexpensive solution to the problem of measuring heart rate on these children. Several units will be required at the Medical University of South Carolina. One item of surplus equipment available in the Biomedical Engineering Department is a drop counter. These units which are relatively inexpensive, costing only \$50 to \$60, provide a meter readout of the number of drops per minute being sensed by the drop counter. This unit basically works by a conductive solution falling between two electrodes and completing an electrical circuit. In other words, each switch closure is recorded as one count. It is felt that these units can be used as a readout device for cardiometers provided a means of converting the ECG signal to a simple switch closure could be obtained. Circuitry is required which can detect the ECG waveform from a two-lead electrode system and then provide a switch closure for each repetition of the ECG wave.

It is desired that the ECG electrodes be on a single wand which can be applied to the infant by merely pressing the wand against the skin surface of the infant. Once the ECG signal is picked up by the electrode system, the signal conditioning circuitry must detect the presence of each ECG waveform and complete the circuit of the drop counter which will be used as the indicating device.

Information on the R-wave detector developed at NASA Lewis Research Center has been given to the researcher along with literature on a commercially available heart rate meter for infants. The researcher is evaluating.

PROBLEM MUSC-8 *An Accurate Method to Control the Temperature of Air Beds*

Premature babies frequently have not developed to the point where their systems can maintain temperature control. As a result, they are kept in incubators where uniform temperature is maintained. It is not unusual for surgery to be required. This immediately presents problems of holding or positioning the baby and maintaining his temperature. The air bed has been found to be an ideal operating platform. The baby is placed on the fluidized air bed and placed in whatever position the surgeon requires. When the desired position is attained, the air flowing through the bed is reduced to the point that the bed is no longer fluidized, and the baby is essentially held in the required position because of the way in which the bed has conformed to the baby's shape when fluidized. Air flow at a lower velocity than that required to fluidize the bed is maintained in order to keep the baby warm. Commercially available thermostats which the researcher has been able to identify have not provided sufficiently precise control. A method to precisely control the temperature of the air flow through the bed is required both when the bed is fluidized and when air flow is reduced below the fluidization point.

It is desired to control the air temperature at the baby (air exit from the bed) to within 0.2°C , and 0.1°C is desirable. Temperature must be adjustable over the range of $31\text{--}35^{\circ}\text{C}$.

Several temperature control systems have been identified in the aerospace literature. Documents describing these techniques have been given to the researcher for his evaluation.

RESPIRATORY DISEASE DETECTION AND TREATMENT

PROBLEM DU-80 *Measurement of Pleural Pressure*

The pluera is a membrane which surrounds each lung. A membrane also lines the chest wall. In a healthy person these two membranes are in contact with each other. A thin film of pleural fluid formed by the pleural membrane lubricates the pleural surfaces as they move against each other when the lungs change size during breathing. In respiratory diseases when a lung collapses or when air or fluid collects between the two membranes, a cavity becomes apparent. This cavity is called the pleural cavity. A measurement of the pressure sustained by this cavity can be employed to detect and diagnose respiratory ailments. Pressure measurements at the proper point in the esophagus provide an indirect method of measuring pressure in the pleural cavity. This has been accomplished by placing a balloon-tipped catheter in the esophagus and recording the pressure changes in the balloon. A telemetry capsule to replace the balloon-tipped catheter would be a significant improvement and would provide refined measurement of pleural cavity pressure.

This problem is presently in the information searching stage.

PROBLEM DU-81 *Detection of Blood Vessels in Bronchi*

Suspicion of lung diseases, particularly lung cancer, often requires that a sample of lung tissue be taken for laboratory analysis. When taking tissue samples from one of the branches of the trachea, a bronchoscope is employed to allow visual examination of the interior of the bronchi (primary branches of the trachea). This visual examination does not allow the determination of the presence of blood vessels in the bronchi. The taking of tissue samples sometimes severs a blood vessel resulting in bleeding that is difficult to control. This danger could be eliminated if a means of determining the presence of blood vessels in the wall of the trachea were available.

A characteristic which might possibly be used to discriminate blood vessels from surrounding tissues is temperature difference. Normally the temperature of the bronchial wall is about the same as the temperature of blood in the vessels of the bronchial wall. However, if the bronchial wall is cooled, the vessels temperature should remain

approximately 2°C higher than that of the surrounding tissue.

The possibility of employing liquid crystals to permit visualization of the temperature pattern of the bronchi wall is under evaluation by the problem originator.

PROBLEM MUSC-6 *Improved Method of Stabilizing a Respirator Tube in the Trachea*

Many patients require external respiration by means of respirators. A significant portion of these patients require that the air be delivered to their lungs by means of a piece of tubing inserted in the trachea. This tube must be maintained in place by some means, and a seal must be maintained when the respirator is pumping air into the patient's lungs, otherwise the air would flow out the tracheal tube, back up around its sides, and out the tracheal incision without ever entering the lungs of the patient. These functions are presently accomplished by means of an inflatable balloon near the end of the tracheal tube. The tracheal tube is inserted into place, and the balloon is blown up by means of a hypodermic until the tube is sealed in place in the trachea. Unfortunately, the pressure employed to obtain a positive seal sometimes exceeds the local blood pressure in the tissue (approximately 15 mm Hg in the capillary bed). When the pressure applied to the walls of the trachea by the balloon exceeds the local blood pressure in the capillary bed, the blood supply to that region is cut off. If the blood supply to the tissues is cut off for long, tissue necrosis occurs and may eventually cause perforation of the trachea at the balloon site. Thus, long-term use of the tracheal balloon under these circumstances can lead to serious complications.

It is generally accepted that the balloon is necessary and adequate for the sealing function provided the blood supply can be maintained to the surrounding tissue. For example, if the cuff could be deflated except for the time when the respirator is actually pumping air into the patient, adequate blood flow could be maintained by the patient to prevent tissue necrosis. A unit is desired (1) to sense the beginning of the inspiration cycle and trigger inflation of the tracheal balloon to seal off the trachea during inflation of the lungs, and (2) to deflate the balloon when inspiration is finished. Fundamentally, a means of inflating and deflating the tracheal balloon in synchronism with the beginning and end of the inspiration cycle is needed.

Under optimum conditions, the balloon pressure required to provide a seal is 10-15 mm Hg and in some cases may require 30 mm Hg. The balloon pressure should be selectable within the range 10-30 mm Hg, and variation from the selected value should not exceed 5 mm Hg. The respiration cycle, of course, varies, but a nominal elapsed time from inspiration to inspiration might be 4-6 seconds, with the inspiration portion of the cycle lasting 2-3 seconds. Balloon inflation and deflation should each take no longer than approximately 0.5 seconds.

To be useful with all makes of respirators, it is desirable that inflation of the tracheal balloon be triggered by the first influx of air from the respirator. Correspondingly, deflation of the balloon should be triggered by reflux of air from the patient's lungs.

The volume of air supplied by the respirator is generally in the range of 700-800 cubic centimeters per inspiration. Of this volume, 500 to 600 cubic centimeters of air actually enters the lungs. The loss can be attributed to dead space and leakage. The cuff must be inflated within 0.5 second of the beginning of the inspiration pulse. The peak pressure from the respirator has a nominal value of 150 mm of water. An acceptable approach might employ a sequencing valve which takes the first part of the pressure pulse from the respirator and applies it with appropriate amplification to the tracheal cuff. When the cuff is inflated (not > 0.5 second), then the sequencing valve would switch the respirator to the tracheal tube and respire the patient.

The nature of this problem suggests that the application of fluidics techniques might be appropriate if the requisite technology can be identified.

Several devices related to this problem have been identified in the open literature. The researcher is evaluating information on these devices.

PROBLEM TU-3 *Lung Sound Detection*

A technique developed to analyze sounds of aircraft engines is being applied to study respiratory diseases in children.

The major cause of illness in children from infancy through adolescence is respiratory disease of which the serious forms include asthma, cystic fibrosis, and bronchitis. Significant research is being conducted both in the causes and cures of respiratory diseases and in better methods of diagnosis of the diseases. This problem statement is devoted to finding a method of improved diagnosis which will improve the treatment of respiratory diseases.

The respiratory system consists of the lungs and the system of tubes or ducts which feed air into the lungs. Air proceeds from the nose and mouth through the trachea which is the central air duct. From this central tube, two branches diverge that eventually feed air into the two lungs. These two branches, called the left and right bronchus, eventually subdivide still further into smaller tubes called bronchial tubes. Each bronchial tube feeds air into and out of a section of the lung, and each tube has a symmetrical counterpart in the other lung.

One useful and simple method to determine whether a portion of the lung is performing properly is to listen to the sounds made by air flow. Usually this is done with a stethoscope, but only one section of the lung can be heard at a time. To compare sections of the lung,

it would be useful to be able to compare the sounds generated by a section of the lung with the sounds generated by the symmetrical counterpart in the other lung.

The basic problem is to detect the sounds from two sections of the chest wall by microphones and display the sounds graphically. Comparison will be made on the amplitude, frequency, and time interval between appearance of the two sounds.

The frequencies of interest will be 50-15,000 Hz. Breathing rates normally will be 25 breaths/minute although a range of 12 to 80 may occur. The amplitude of the sounds of interest is not known. Measurements will be made on children from infancy to adolescence in a hospital clinic.

In the basic description of the problem, the researcher desired simply a strip chart recorder and microphone combination. However, the Team advised him that far more information could be gained by going to spectral analysis such as had been used in analyzing aircraft engines. A difficulty arises in spectral analysis in that real time spectral analysis is required because of the rapidly changing information in lung sound. Thus a simple scanning-filter spectral-analysis technique was insufficient because of the time response required. A computer search of the NASA document file revealed that NASA had done considerable work in spectral analysis--particularly as pertains to aircraft engines and vibration for vibration testing of spacecraft. The Team proposed to the physician a system, shown in Figure , composed of a microphone, amplifier, and envelope detector which could be fed to a dual-channel strip chart recorder. This dual-channel system, which is now operational, will allow time delay measurement for respiratory sounds between similar lobes. In addition, the output of the amplifier could be fed into a spectral analyzer similar to that used in aerospace applications.

The spectral analyzer is now operational and clinical trials are underway. Initial results indicate that useful information is being obtained.

The Team feels that this highly significant potential technology application will result in a new diagnostic tool of particular importance in the pediatric field for detection of asthma, cystic fibrosis, and bronchitis.

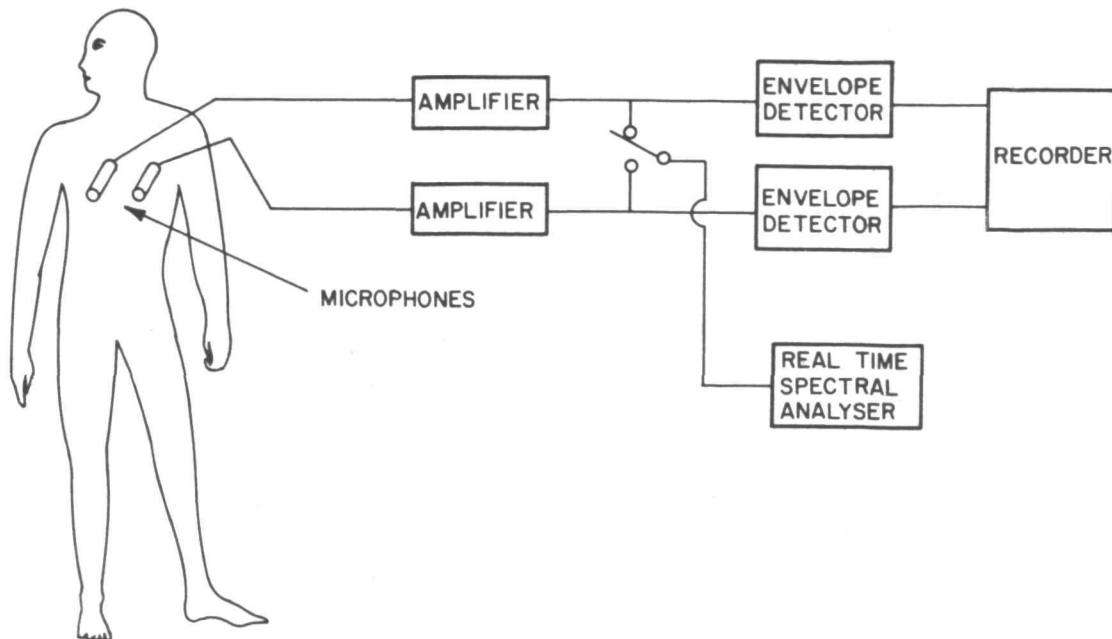

Figure 25. Block diagram of lung sound analysis system.

PROBLEM VAM-6 *Negative Pressure Chamber*

Respiratory distress syndrome is the major cause of death in premature infants. This is a condition of the newborn in which the lungs are collapsed. Researchers at the University of Miami conceived the idea of creating a negative pressure chamber in which the upper part of the infant's body is placed. The negative pressure around the thorax helps the baby inflate his lungs and maintain the proper residual volume of air. This technique has proved very successful in saving the lives of several infants at the University of Miami. The major problems with the existing system are:

- (1) Caring for the baby is complicated (e.g., changing the diaper) since the baby's lower body must remain in the negative pressure chamber, and
- (2) The chamber cannot accommodate infants of differing size.

It is desired to find a method of creating a negative pressure around the infant's thorax without completely enclosing the lower part of the body in the chamber.

From an engineering point of view, one might think that creating a positive pressure around the infant's head would be equally effective; however, there are two reasons why this approach is undesirable:

- (1) The circulatory system is adversely affected by positive pressure.
- (2) Air easily reaches the infant's stomach causing discomfort.

The technology that was employed to build the lower body negative pressure system for an experiment to be carried out during NASA's Skylab Mission, scheduled for 1973, appears to be directly applicable to this problem.

IMPROVED SURGICAL PROCEDURES

PROBLEM EU-15 *A Small Moisture Resistant Microphone*

During anesthesiology, it is desirable to monitor the state of the patient's cardiovascular system so that the anesthetic administration can be exactly tailored to the requirements of the particular surgical situation. The chest cavity is, generally speaking, the area in which the surgeon is operating, and the anesthesiologist does not have available this area to pick up information which can be used by him to monitor the anesthetic state of the individual. The researcher is developing an esophageal probe to obtain the information required by the anesthesiologist. One of the transducers on the esophageal probe that is required is a transducer for picking up the heart sounds. It has been clinically proved that heart sound changes can be detected during anesthesiology. A successful esophageal probe would permit the gathering of data and a correlation of information to permit better anesthetic administration procedures during surgery.

The required frequency response of the desired microphone is 25-50 Hz with a flat response over that range. Size is very important in this particular application, and a maximum size of 3/16" in diameter or in all dimensions is permissible. Actual sensitivity requirements have not yet been defined. Since the microphone will be inserted in the esophagus, it is necessary that it be moisture resistant, if not completely waterproof. It should also be amenable to some form of sterilization procedure. No useful technology has been identified. Searching is continuing.

PROBLEM OF-1 *Blood Embolism Detection*

Ultrasonic flow detectors developed by NASA may prove useful in detecting embolisms occurring during open heart surgery.

The last decade has shown a dramatic increase in the use of open heart surgery as a tool for correction of heart defects. Many of these defects such as valvular disorders, septal defects, shunts, patent ductus arteriosus, and tetralogy of Fallot can be corrected

by open heart surgery. If the heart is opened, a heart-lung machine is used to provide the pumping action of the heart and oxygenation of the blood supply. Many specialists feel that the weakest link in the machine is the oxygenator--one of the difficulties being the production of gas embolisms which can stop blood circulation if lodged in a small artery. In addition, surgery can break loose small particles which can stop blood circulation. It is estimated that 20% of open heart surgery cases at present result in a neurological deficiency (reduction of blood flow to the brain); thus a means of detecting the embolisms as they occur is vital for successful open heart surgery.

Because the embolisms occur during open chest surgery, attachment of electrodes is easily accomplished. Particle sizes as small as one micron should be detected in the output of the heart-lung machine. The particles can be either gas or solid.

The Team contacted Mr. Sal Rositano of Ames Research Center who has had experience in the measurement of blood flow. Mr. Rositano advised that the ultrasonic blood flow units developed for NASA by L & M Electronics would detect embolisms of the type of interest to the problem originator. The problem originator was advised of this fact, and he is attempting to obtain funds to implement the solution.

PROBLEM TU-25 *Blood Damage Measurement*

Recent medical developments in oxygenators have improved the probability of patient support in cases where temporary assistance in lung function is required. Examples of such use include infants with certain diseases and adults with crushed chests due to accidents. Some damage to the blood results from oxygenators, and a new means of measuring blood damage is required. Existing tests usually consist of hemolysis analysis.

Possible measurement techniques include partial pressure O₂ and CO₂, cell mass, lactate/pyruvate, plasma hemoglobin, protoglandin, serotonin, and platelet damage.

DETECTION AND TREATMENT OF DENTAL AND ORAL DISORDERS

PROBLEM VAM-7 *Bacteria Detection Using Fluorescent Labelling*

Researchers at the University of Miami have discovered an unusual type of bacteria which causes tooth decay in laboratory animals. This bacteria has now been found in humans and is possibly a major cause of tooth decay in man. Fluorescent techniques are employed to discover the presence of this bacteria in humans. This is possible because of the development of a vaccine which makes laboratory animals produce antibodies to attack the bacteria. These antibodies

are labelled with a substance (fluorescin thiocyanate) which makes them fluoresce when excited with ultraviolet light. When the labelled antibodies are applied to a culture having these bacteria, they become bound to the cell wall of the bacteria. The culture is then washed and only those antibodies which are bound to the bacteria remain. Therefore, when the culture is viewed under a microscope using ultraviolet illumination, the antibodies can be spotted, thus signifying the presence of the bacteria which cause tooth decay.

To find out how many of these bacteria are present, all bacteria in the culture are allowed to grow. It was discovered that a second type of bacteria which normally resides in the mouths of humans exhibits a natural fluorescence. The autofluorescence of the second bacteria complicates the detection of the labelled antibodies. It should be emphasized that the autofluorescence presents a problem only when all bacteria are allowed to grow (i.e., it is only when the autofluorescing bacteria are in colonies that the autofluorescence is of sufficient intensity to be observable). A means of suppressing the radiation due to autofluorescence is needed. The Team is currently contacting knowledgeable persons at NASA field centers.

BASIC MEDICAL RESEARCH PROBLEMS

PROBLEM DU-72 *Shadowing Methods for High Resolution Electron Microscopy*

Better methods are needed to obtain very uniform, thin (10-30Å) films of platinum or other heavy metal deposited on cold biological specimens in the freeze-fracture method of electron microscope studies of cellular ultrastructure. Regularity at the level of 5-10Å is desired.

The problem originator is investigating details of cellular membrane structure, and the principal tool in this important fundamental research is the transmission electron microscope. The biological specimen is prepared by the freeze-fracture process and "shadowed" with platinum to enhance contrast and to reveal three-dimensional detail. While modern electron micrographs have resolution limits of several Angstroms, electron micrographs of cellular ultrastructure are generally limited in resolution to the range 20-100Å, and much of this limitation is due to the shadowing process itself. Improvement in shadowing is the subject of this problem statement.

Shadowing is simply the evaporation in vacuum of a thin layer (10-30Å typically) of a heavy metal (such as platinum) at an oblique angle (often approximately 45°) onto the face of the freeze-fractured specimen. The specimen temperature is 80°K to 150°K when this occurs. The shadowing material must be heavy (relatively high atomic number) to provide adequate electron scattering in the transmission electron microscope. The requirements of geometrical shadow production to emphasize the surface relief features, together with the low specimen temperature, have made vacuum evaporation the only method used thus far for deposition of the shadowing material.

The Team identified a researcher at Langley Research Center who suggested the use of electron bombardment for film evaporation. The researcher is presently attempting to obtain facilities to perform the recommended procedure.

PROBLEM DU-82 *Maintaining the Position of a Telemetry Capsule in the Digestive Tract*

Telemetry from within the human body by means of small sensing and transmitting capsules is becoming an increasingly important method of making physiological measurements that were heretofore impossible. As an example, useful measurements that might be made in the digestive tract are esophageal pressure, stomach pressure, pO_2 , pH, etc. Certain measurements require that the sensing capsule remain stationary along the tract even though the natural reaction of the digestive tract is to continuously propel any matter which enters the system. A means of retaining the sensing capsule at a desired point in the digestive tract would allow needed measurements to be made over a period of time that does not depend on the body's natural reaction. The method for retaining the capsule should not be dangerous or make the patient uncomfortable.

A problem statement is being prepared for dissemination to the NASA field centers.

PROBLEM EU-13 *A Sampling Manifold for Use with Multiple Gases*

The investigator is conducting basic research into areas of sensory input to the brain; specifically, he is studying those parts of the brain in which odors are detected. The hypothalamus is one such area. In certain animals the olfactory stimulus is a very strong stimulus. One such animal is the rat. In this study the researcher is measuring the olfactory firing patterns to various odors. For example, certain neurons respond to certain odors. In order to study this response to certain odors, it is necessary to present to the animal sequentially different odors. An automatic method for presenting these odors to the experimental animal is desired. It is desired to present at least ten different odor stimuli to the animal sequentially. In order to do this rapidly, a switching mechanism is required to automatically distribute the odors from the various reservoirs to the experimental animal. Dead space is a problem so that the animal must be as near the sampling port as possible.

Basically, a means of switching the output of various gas (odor) reservoirs sequentially into a single manifold from which the experimental animal will be exposed is desired. The switching method must permit switching from one gas to another rapidly (approximately 10 seconds) and simply (possibly by merely closing a switch). It is necessary that the material from which the manifold is constructed must not absorb odors to any significant extent. This is necessary to prevent contamination of succeeding odors when switching from one gas to another gas. The researcher is presently using Teflon or glass as the tubing to conduct the odors to the animal.

A pressure scanner valve developed at Ames Research Center for wind tunnel use appears useful in this application. Written information on this valve has been obtained from Len Sauer, TUO at Ames Research Center. The researcher is now evaluating the scanner valve information.

PROBLEM EU-16 *Means of Scrubbing Odors*

Several parts of the brain detect odors, of which the hypothalamus is one such area. The researcher is studying those parts of the brain in which olfactory information is processed. In this study rats are being used as experimental animals because olfactory stimuli are quite strong in the rat. It appears that certain parts of the brain respond to certain odors. In order to study the neuronal firing patterns of the brain, various olfactory stimuli are presented to the experimental animal and the neuronal firing patterns are monitored. Glass and Teflon are used as tubing to convey the various odors to the experimental animal. Part of the tubing and apparatus is connected to the animal, and containers filled with various odor gases are sequentially hooked up and odors fed to the animal. In the part of the apparatus which remains attached to the animal, residual odor from the previous gas is present. It is not known how long these residual odors remain present in the tube when a new gas is introduced or what the residual gas concentration is. This uncertainty, of course, leads to uncertainty in the validity of the data. A means of rapidly removing residual odors from glass or Teflon tubing is desired. The removal process should not take longer than one minute and it is preferable that the method not be harmful to experimental animals. A search of the aerospace literature has been made. The researcher is currently evaluating the results of that search.

PROBLEM MISC-9 *pO₂ Telemetry Capsule*

Diarrhea may be due to various causes ranging from acute infections to psychogenic factors. Current research indicates that bacteria which normally reside in the mouth can, under certain conditions, give rise to diarrheal states. There are two types of such bacteria: one which must have oxygen to live and another which cannot thrive in the presence of oxygen. Oxygen exists in the gaseous state throughout the digestive tract and must remain relatively constant to provide for the proper balance of bacteria.

In order to learn more about the conditions that give rise to diarrhea and to evaluate the use of antibiotics in altering the oxygen content of the digestive tract, this researcher would like to measure the partial pressure of oxygen in the lumen of the gut at various points. This problem has baffled researchers for several years.

The researcher feels that the best solution would be a swallowable capsule for measuring and telemetering the partial pressure of oxygen as it passes through the gut.

A search of the aerospace literature failed to uncover a solution to this problem. The Team learned of a commercial device (a swallowable telemetry capsule) for measuring the partial pressure of oxygen in the digestive tract which should be available within the next few months. This should offer a solution to the problem.

PROBLEM NEHSC-1 *Miniature Telemetry*

The researcher is studying the effects of several drugs on the immature opossum. The opossum is a particularly well-suited animal for these studies. The gestation period of the opossum is approximately 12 1/2 days. At birth the embryos weigh approximately 100 mg and are approximately 5 mm long. They can be considered embryos at birth, and much of their development occurs during the time they are in the pouch. Consequently, physical access to the embryo in the pouch permits study during this rapid development stage. Most other mammals remain as unborn embryos during this development period. It is, of course, extremely difficult to monitor development of unborn embryos. As a result of the fact that much of the embryonic development occurs while the immature opossum is in the pouch and thus relatively accessible, the opossum is very appropriate for such studies. The basic problem is to telemeter several physiologic signals from the immature opossum in the pouch to a receiver in the same room. A range of 15 feet is considered adequate. If the telemetry unit is to be directly attached to the newborn opossums, the size of the telemetry unit could not exceed 125 cu. mm including battery, and the weight maximum is 100 mg.

A search of the NASA literature has failed to reveal any telemetry equipment of the small size and weight required in this application. No commercial units which approach this range of size and weight have been discovered either. The problem is presently being reviewed and a final search being made for potential solutions. If none is found, it is expected that the problem will be closed since the problem requirements appear to be beyond the present state-of-the-art in telemetry system development.

PROBLEM NEHSC-2 *A Means of Characterizing Seizures in Laboratory Animals*

The researcher is studying the effects of various drugs on laboratory animals. One of the drugs sensitizes the animals so that they are susceptible to seizures. External sensory input is thought to trigger the seizure. It is desired to determine which sensory input is acting as the trigger. There are a number of possibilities including audiogenic induction, photo stimulation, tactile stimulation, and stimulation through the vestibula apparatus. A search of the NASA literature has been conducted seeking information on tests and equipment which can be used to provide isolated stimulation to each of the sensory inputs so as to isolate the exact sensory input acting as the trigger. A search has been delivered to the researcher for his evaluation.

PROBLEM TU-10 *Quantization of Heart Tissue Hardness*

Techniques developed to study aerospace materials have been used to study the human heart during pathological examination.

Examination of the various organs of the human body following death can reveal not only the cause of death, but other conditions affecting the person at the time of death. Research at the Tulane University School of Medicine has shown that a peculiar softening of the heart tissue can be seen in some patients that did not die of heart disease. The cause of this unusual softening is not known, but a number of factors are believed to be important. For example, there appears to be an infarction and a definite softness in the heart tissue. The reasons for this are being studied in experimental work using rats in which the blood is cut off temporarily from portions of the heart in order to discover the changes in the heart tissue. Simultaneously, studies are being conducted on human hearts in autopsy examinations to determine whether this soft region can be attributed to any known condition of the human being prior to death. In order to carefully characterize these soft regions, a means of measuring softness of the heart tissue is required. The researcher has attempted to use a conventional eye tonometer for this purpose but the results have not been reproducible.

The Team performed a computer search of the NASA document file on measuring hardness of soft materials such as sponge rubbers and plastics. This search revealed that Mr. John Schell of Marshall Space Flight Center had conducted experiments on a variety of hardness testing techniques which appeared to be applicable to this problem. The Team visited MSFC for discussions with Mr. Schell and discovered that a number of techniques in current use at MSFC were applicable to this problem. Mr. Schell not only indicated the type of instrument required for this purpose but also, of more importance, indicated the procedures necessary to obtain reproducible results. This information was then relayed to the physician at Tulane University School of Medicine who purchased a special instrument which had been modified for his purposes by Mr. Schell; the physician also incorporated Mr. Schell's suggestions in his testing procedures. The experiments by the physician are currently underway utilizing the NASA techniques, and the results to date have been successful. It is anticipated that the results of this experiment will have great medical significance.

PROBLEM TU-20 *Cell Area Measurement*

The problems of aging are being attacked in order to better understand the processes of aging. One area of interest is glandular change, particularly the testes, pituitary gland, and adrenal glands. This research concerns the relationship between biochemical changes and morphological changes in certain tissue.

The cells will be examined under a microscope which can be projected so that the areas can be drawn on a paper sized 8 in. x 10 in. The cell area and the interstitial area need to be measured to an accuracy of ± 1 per cent.

A problem statement was circulated to the NASA Field Centers and several useful suggestions were received. An excellent suggestion for a planimeter has been selected and will be implemented depending on availability of funds.

PROBLEM UNC-60 *Counting Exposed Points on Autoradiographs*

A means of counting exposed points on autoradiographs to be used in the study of cellular uptake of various chemicals is needed. Medicine has not yet reached the point where an ailment can be cured or its condition improved by chemical means without some likelihood of harmful side effects. Improving the effectiveness of medicines while minimizing harmful side effects seems possible only if there is a better understanding of what specific chemicals accomplish on the cellular level. One of the means of studying chemical uptake of various portions of the cell is autoradiography. In this process, chemicals of interest are made slightly radioactive and administered either orally or intravenously to a patient (or an experimental animal). After the chemicals have had time to reach their destination, tissue samples are taken and are covered with a film of photographic emulsion. The radioactivity in the tissue then exposes the emulsion and gives an indication of the relative uptake of the chemicals in various portions of the cell.

One of the major problems encountered with this technique is the tedious process of manually counting the exposed silver halide grains of the emulsion. A method of automatically counting the number of exposed grains in the violet, red, and white areas of the autoradiograph is needed so that the cellular effects of specific chemicals can be studied more rapidly and in greater detail.

The Team is currently in contact with an engineer at Langley Research Center who is interested in determining the applicability of his work in high resolution TV systems to this problem.

PROBLEM VAM-4 *Microanalysis of Hormone Levels in Blood*

The effects of noise on man are not well understood. The increasing awareness of noise pollution in our environment has prompted several investigations of the physiological effects of noise on man. The problem originator plans to investigate the effects of noise by performing a series of experiments with a Rhesus monkey. The monkey is to be subjected to various types of noise. Researchers intend to monitor the monkey's EKG, EEG, and blood pressure levels during the experiment. It has been demonstrated that certain hormones, in particular cortisol and the growth hormone, are particularly sensitive to physiological stress. If hormone levels in the monkey's blood could be monitored, then it would be possible to learn more about the relationship between hormone levels and physiological stress. More importantly, it would provide an answer to the question, "Can man adapt to stress caused by noise?" This question can be answered only if it can be determined whether or not there exist long term shifts in blood hormone levels as a result of the noise stimulus.

At present, a rather large sample of blood is required to determine the hormone levels. This prohibits frequent determination of the hormone levels. A technique is needed which will allow the determination of the levels of cortisol and the growth hormone in blood from only a few drops of blood.

NASA scientists have had to cope with a similar problem in planning for the 1973 SKYLAB mission. In order to keep a close check on the state of health of the astronauts, a technique for microanalysis of blood constituents was developed by AEC under NASA sponsorship. The technique is currently under evaluation by the problem originator.

OTHER, MISCELLANEOUS

PROBLEM DU-84 *Liquid Radiation Shields*

Laboratory experiments involving radioactive materials must be shielded to protect the persons performing the experiment. A commonly employed shielding technique makes use of small lead "building blocks" which are stacked around the experimental setup. This technique is cumbersome and inadequate when shielding glass pipes, flasks, etc.; however, the main problem with the lead blocks is the inability to observe the experiment. It is relatively simple to construct a vessel of glass which, when filled with a high density transparent liquid, will permit one to observe the experiment. Lead perchlorate has been used for this purpose; however, lead perchlorate under certain conditions becomes explosive. A more appropriate liquid radiation shield is needed.

Both a search of the aerospace literature and contacts with NASA Field Centers have failed to produce a solution to this problem. An alternate approach is being considered.

PROBLEM MUSC-5 *Means of Controlling Infusion Pressure*

It is common procedure in hospitals to infuse various fluids into the blood vessels of patients. Various methods from the slow gravity feed (the so-called "glucose drip" is an example) to hypodermic injection are employed. Many times fluids are administered to premature babies by hypodermic injection through the umbilical cord. It is important that a specified minimum pressure is not exceeded during injection. It is possible with premature babies to generate sufficient pressure during hypodermic injection to rupture the intestine wall of the baby, and it has indeed happened.

A means of controlling the infusion of fluids into patients so that a maximum pressure selectable between 20 and 100 mm Hg to an accuracy of ± 5 mm Hg is required. The technique must be simple, virtually foolproof, and inexpensive. Because of the cost and simplicity requirements, the researcher is not inclined to consider electronic sensing and feedback techniques. The device must be used by nurses without instrumentation training.

A driven pump with an adjustable clutch might be used if a proper clutching mechanism could be devised. Other less conventional techniques will also be considered provided the overall requirements can be satisfied.

Several methods of controlling the infusion pressure have been identified. Information on these techniques has been given to the researcher who is presently evaluating them with respect to the requirements of this problem.

PROBLEM MUSC-7 *Automatic Recording of Time on Magnetic Tape*

Intensive care units (ICU) frequently have patient emergencies in which a number of people (up to 12) are working on a single patient. In these emergencies, there is not time for formal record keeping, and when the emergency is over, it is difficult for the participants to remember the sequence of events which occurred. Yet it is important that everything done to the patient and its sequence and timing be known. It is not unusual to obtain different accounts of the sequence of events from those involved in the emergency. The researcher is developing a four-channel magnetic tape recording system for the ICU. The recording unit would be manually operated during the time that some routine procedure is occurring to a patient (e.g., administration of medication) or when an emergency occurs. During the routine and emergency procedures, each action performed on the patient along with the time will be verbally recorded on a voice channel of the magnetic tape. Once a system has been developed to handle this emergency record keeping, it is clear that it should also have sufficient versatility to permit its use for the record keeping involved in routine administration of care of the patient. In order to accomplish this the nurse, when administering care to the patient, would record the procedure she is performing and the time on the voice channel. As a further indexing system, it is desired that the tape recorder be turned on automatically every 30 minutes and the time automatically recorded on a separate time channel of the magnetic tape.

Basically, a means of automatically recording time every 30 minutes on one channel of a magnetic tape recorder is desired. The tape recorder will normally only be operative for the small period required to record the time every 30 minutes. If some routine or emergency procedure should occur, however, then the tape recorder will be manually activated and data will be inputted to one or more of the other three channels. The time channel will be required to continue to record the time at 30-minute intervals.

A suggestion has been received from George Washington University involving modification of commercial equipment. Evaluation of this suggestion and another commercial unit is in progress.

PROBLEM MUSC-9 *An Omnidirectional Microphone for Intensive Care Units*

Intensive care units (ICU) frequently have patient emergencies in which a number of people (up to 12) are working on a single patient. In these emergencies, there is not time for formal record keeping, and when the emergency is over, it is difficult for the participants to remember the

sequence of events which occurred. Yet it is important that everything done to the patient and its sequence and timing be known. It is not unusual to obtain different accounts of the sequence of events from those involved in the emergency. The researcher is developing a four-channel magnetic tape recording system for the ICU. The four recording channels will record the following information: (1) time every 30 minutes, (2) ECG, (3) EEG, and (4) voice channel. Only the time channel will be automatically operated. A timing unit will turn on the tape recorder and record the time every 30 minutes. The recorder will be turned on manually to record the other three channels. The recording unit would be manually operated during the time that some routine procedure is occurring to a patient (e.g., administration of medication) or when an emergency occurs. During the routine and emergency procedures, each action performed on the patient along with the time will be verbally recorded on a voice channel of the magnetic tape.

In order to record the actions performed by all the personnel working around the patient's bed, a sensitive microphone with essentially hemispherical coverage is required. The maximum pickup range is 10 feet, but the spoken word should be clearly recorded at 10 feet. It must be accomplished without requiring the speaker to "talk to" the microphone. Voices to be recorded will be at normal conversation level.

A search of the aerospace literature has been made. No suitable solution to this problem has been identified. Searching is continuing.

PROBLEM MISC-16 *Cerebral Oxygen Measurement*

Retarded children (IQ of 30-50) may be caused by oxygen deprivation to the brain. Studies of this phenomenon are underway in an attempt to find the cause of this terrible affliction. It is possible that hypoxia effects similar to that caused by acceleration may be a causal effect. A noninvasive method of measuring cerebral blood oxygen is required.

A noninvasive technique capable of measuring blood oxygen from 80%-100% saturation is needed. Arterial blood contains oxygen of about 20 volumes percent with 0.3 percent held in solution and the remainder as oxyhemoglobin. An information search is being studied.

PROBLEM MISC-17 *An Underwater Core Sampling Unit*

Current methods of obtaining cores of deposits on the ocean floor use screw cores which require the exertion of torque by the diver to penetrate the ocean floor. Because the diver is virtually weightless, it is very difficult for him to exert much torque. As a result, unless the soil is very soft, only shallow cores can be easily obtained.

A portable device which can be employed by a diver to obtain cores from the ocean floor is desired. Five to eight foot penetration is

desired in soft rock such as limestone or coral. An information search is being conducted.

PROBLEM NEHSC-3 *A Means of Determining the Quantity and Size of Cell Colonies in a Transparent Gel*

In assessing the effects of the environment on man, one area of interest is the ability of environmental effects to produce mutation of cells. Special cell cultures have been developed at the National Environmental Health Sciences Center to permit study at the cellular level of the mutant capability of various environmental effects. A special cell culture has been developed from mouse lymphoma cells. These cells, when placed in free suspension in a gel medium, do not divide and produce cell colonies under normal circumstances. If, however, a mutation takes place, then the mutant cells divide and produce colonies. The number of colonies and the relative growth rates will provide information on the effectiveness of various environmental mutants to which the cells can be exposed. Basically, a means of quantitating the number of colonies produced and their sizes (or the size distribution) is desired. The colonies to be detected are contained in flat, plastic bottles which contain the gel medium. It is desired to measure the colonies over a period of time in order to obtain a growth rate for the colonies and distinguish between those colonies that are growing slowly and those that are growing rapidly. Any system to be useful must be capable of detecting colonies as small as 0.1 mm; however, detection of smaller sizes is desirable. Extremely complex and expensive solutions are not acceptable, thus eliminating flying spot scanners and digital image processing. Presently, optical data processing is being evaluated for application to this problem. Contacts have been made at the NASA Goddard Space Flight Center to initiate discussions with NASA scientists in the field of optical data processing.

PROBLEM TU-9 *Human Voice Analysis*

An aerospace technique for improving speech transmission from aircraft is being applied in analyzing speech defects.

Approximately 6-7% of the population is considered to have either temporary or chronic speech defects. In chronic cases, inadequate understanding of the causes or speech defects hampers treatment. For example, one speech defect is characterized by a pitch that is either too high or too low and can be caused by contact ulcers, polyps, polypoid degeneration, or chronic laryngitis.

A technological impediment exists in the analysis of speech defects because of the inability to precisely quantize characteristics of the human voice. This is further complicated by the fact that many changes in the human voice are easily detected by the ear but are often quite subtle in their spectral density or frequency changes. A number of

techniques have been employed in an attempt to quantize the human voice, but to date no technique has been found which permits the therapist to measure changes in the human voice before and after therapy.

Speech consists of a broad fundamental frequency and many harmonics. Small shifts in fundamental frequency and amplitude cause large changes in the human voice. Frequency spectrum analysis must be able to detect fundamental frequencies that range from as low as 50 Hz for low-pitched male voices to more than 400 Hz for high-pitched children's voices. The technique must measure fundamental frequencies to a precision of 1 cps and amplitude to a precision of 1 db. The analysis technique must take into account both fundamental frequency and harmonics and their relation to the fundamental frequency. Although not required, real time analysis is desirable.

A computer search of the NASA document file was conducted and 136 citations were noted. Among this large number, several documents appeared to be of particular significance in that they discussed speech analysis and, in particular, fast Fourier transform as applied to speech analysis. These documents were concerned with determining the spectral differences between several languages and

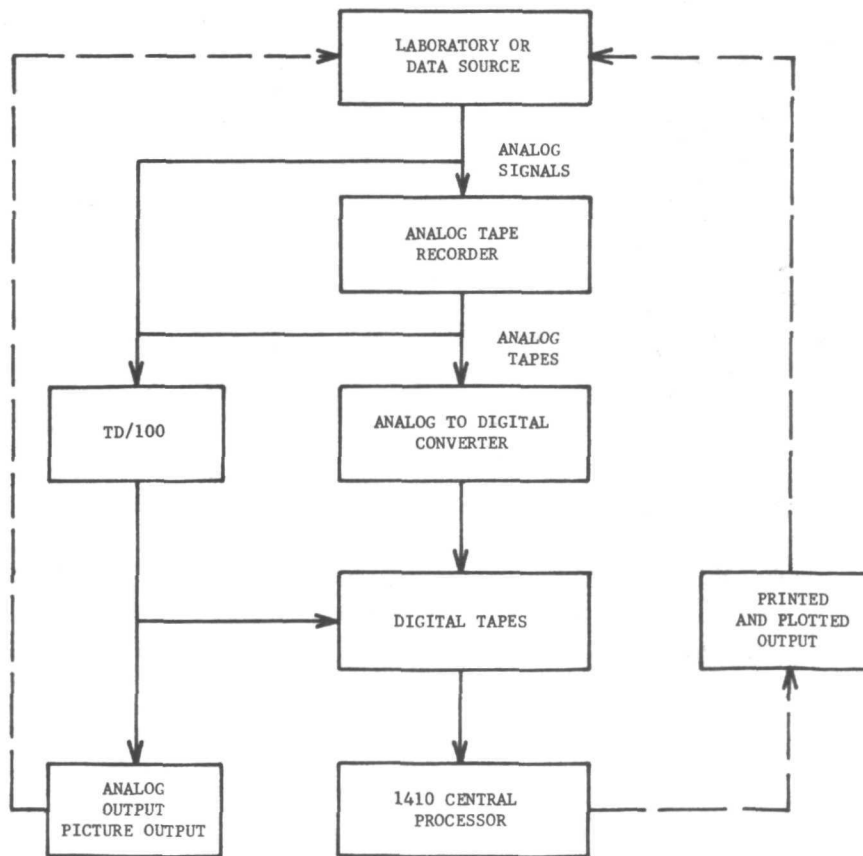

Figure 24. Block Diagram of Voice Analysis System

in detecting the voice in a noisy environment (for example, spacecraft). The techniques discussed in the documents appeared to be directly relevant to the problem of speech therapy, and the problem originator expressed strong interest in pursuing this approach. The use of the fast Fourier transform and a digital computer for analysis was of exceptional interest because of the availability of a computer capable of handling the fast Fourier transform analysis at the Tulane University School of Medicine. This computer was in the Neurology Department, but arrangements were made for its use by the Otolaryngology Department. At the present time, the fast Fourier transform techniques, outlined in Figure 24, are being implemented on the digital computer for analysis of tape-recorded speech, and comparisons are being made before and after therapy. The initial portion of the study is to establish a baseline of information from which changes can be documented. The physician has indicated that the initial results are favorable, and it is anticipated that an advance in speech therapy will result.

PROBLEM TU-26 *Water Purification*

Patients with burns over large areas of their bodies have a high probability of infection as well as extreme difficulty in maintaining an electrolyte balance. The Tulane team plans to surround the body in an electrolyte medium (water plus additives) which will be continuously circulated to remove body wastes. A means of purifying the water for recirculation is needed.

Purification must remove excrement, urine, human cells, and bacteria while allowing Na, K, Cl, and HCl to remain. The rate of water flow will be 4 cu. ft./sec.

Information search has been initiated.

PROBLEM VAM-5 *Safety Mechanism for Patient's Medicines*

There is a growing concern over the problem of the use of medicines for a longer period of time than prescribed by the physician. Certain antibiotics, for example, if ingested some time after their expiration date can cause renal failure and therefore death. Thus, expired or no longer prescribed medicines present a potential hazard to the patient and his family. The problem becomes even more serious with elderly patients who are not careful about the medication they take and with persons having character disorders who might impulsively begin taking whatever medicine is available in a suicidal attempt.

As a protective measure for the patient and his family, it is desirable to have a warning device which would give an indication when the time for which the medicine was prescribed has passed. In the ideal case, the medicine should no longer be accessible to the patient. Perhaps a coating applied to the medicine or a special container could cause destruction of the medicine after the period of the prescription has elapsed.

A search of the aerospace literature has produced references to information that appears useful. The results have not yet been evaluated by the problem originator.

PROBLEM WF-56 *An Improved Fluid Pressure Calibration System*

A significant problem in hospitals and medical research institutions involves the testing and calibration of equipment used in taking physiologic measurements for research and diagnostic use. Most hospitals and medical research institutions have in their inventory a large number of pressure transducers of varying manufacture and design that are employed by investigators in their research programs and by clinical personnel in the diagnosis and treatment of patients. These devices have real value only when their performance is within specifications. Indeed, when transducers are out of calibration, the indicated results lead to false conclusions. It is extremely desirable that all pressure transducers used for research and clinical purposes alike be within calibration in order not to yield inaccurate and misleading data. A calibration system which could be used to check and verify the accuracy of pressure transducers employed in the hospital and the medical research facility would be a very useful addition. Basically, a calibration unit consisting of a pressure wave generator, an accurate standard transducer, a pressure changer, and appropriate manifolding is desired. The pressure generator must be capable of generating fluid pressures in the changer from near zero to approximately one atmosphere of pressure. Frequency response of the pressure generator within a given pressure output should be constant ± 5 over the frequency range of 0.1-- 150 Hz.

A potential solution to this problem was discovered in the aerospace literature as a result of a computer search. The solution to this problem is being reengineered at the University of Virginia.

APPENDIX C

FUTURE NEEDS FOR BIOMEDICAL TRANSDUCERS

(Paper presented at the Transducer Conference of the Institute of Electrical and Electronic Engineers, Washington, D. C., October 6, 1971)

FUTURE NEEDS FOR BIOMEDICAL TRANSDUCERS

by

F. Thomas Wooten

Presented

at the

INSTITUTE OF ELECTRICAL AND ELECTRONIC ENGINEERS

Transducer Conference

Washington, D. C.

October 6, 1971

This work supported under Contract #NASW-2273

by the

National Aeronautics and Space Administration

FUTURE NEEDS FOR BIOMEDICAL TRANSDUCERS

INTRODUCTION

The past decade has witnessed a dramatic increase in the use of engineering techniques in medicine. The increased emphasis on the interaction of these two scientific disciplines has resulted from a recognition that modern medical problems are losing their identity with a single traditional discipline. It follows that the major accomplishments of the future will be achieved by the utilization of carefully managed diverse interdisciplinary efforts.

With the increasing requirements for engineering techniques in medicine, the transducer has become an important and critical link in the chain between patient and physician. Since in many cases a transducer is the limiting factor in a sophisticated instrumentation system, careful study is required to distinguish between what *should* be monitored in a biomedical environment and what *can* be monitored.

In the broadest definition, a transducer can be considered to be any energy conversion device; but for the purpose of this discussion, the words transducer and sensor will be considered synonymous. It is a mistake to think of a transducer as an isolated device coupled to a signal processor because in solving significant problems, the total system must be considered.

PRESENT BIOMEDICAL USES FOR TRANSDUCERS

Biomedical transducers are used in the research laboratory, in the analytical laboratory, and in the clinical environment (including monitoring). In the research laboratory, the detailed studies of both cellular and comparative physiology have increased the need for means of sensing physiological processes--particularly at the cellular level. In the analytical laboratory, many needs exist for the analysis of such things as body fluids and cancerous

tissue. In the clinical environment, transducers are used as a diagnostic tool as well as in patient monitoring. In the area of patient monitoring, there is an increasing use of intensive care units, coronary care units, and respiratory care units in which sensors are taking an increasingly important part in monitoring the patient's condition over a 24-hour period. As a diagnostic tool, sensors are being used to measure physiological functions that the physician cannot measure otherwise.

FUTURE REQUIREMENTS FOR BIOMEDICAL TRANSDUCERS

The need for biomedical transducers can be divided into three general areas: improvements in existing transducers, development of transducers which exploit new physical science phenomena, and development of transducers which utilize new physiological phenomena.

Improvement of Existing Transducers

The first area concerns improvements in existing transducers in such areas as size, sensitivity, reliability, cost, noise, stability, safety, frequency response, and signal-to-noise ratio. Although these changes are evolutionary, they will require the highest quality of engineering effort simply because the easy improvements have already been made. The following are examples of some of the transducers that need improvement:

- ° Pressure transducers are needed in both the cardiovascular and urinary systems. There is a definite need to improve the existing pressure transducers--particularly in size, sensitivity and stability. In addition, as for all transducers, a significant reduction in cost is needed because of the dramatic increase in health care costs.
- ° For the measurement of both urine and blood flows, a smaller and more sensitive catheter flowmeter is needed. The existing units which use the electromagnetic principle are too large and too insensitive for clinical needs.
- ° There is a need for a low cost fluoroscopic X-ray image intensifier which has an improved sensitivity to X-rays, a greater brightness, and a time lag small enough to allow real time viewing of such things as heart action.

- ° Endoradiosondes are small devices, swallowed by the patient, which transmit information to a nearby receiver. Although pH has been measured for several years, there is also a need for measuring such things as partial oxygen pressure and bleeding sites by the use of these devices. In addition, there is a definite need for improved stability of the existing endoradiosondes.
- ° A further example concerns taking biopsies of small samples of tissue in the bronchus for lung cancer detection. At the present time, no device exists which can tell the physician whether the forceps are about to sample not only the tissue of the bronchus but also a nearby blood vessel, a situation which can result in an embarrassing hemorrhage.

Development of Unexploited Physical Phenomena

The second major class of transducer improvement is the need for transducers which utilize unexploited physical science phenomena. Some of the phenomena which have been used include mechanical, optical, acoustical, chemical, resistive, inductive, capacitive, photoelectric, piezoelectric, and thermoelectric transducers. However, it is clear that many problems cannot be solved by evolutionary changes but will require the innovative uses of new physical science phenomena. Many examples can be given:

- ° Ultrasonics has been used in a variety of medical applications including detection of cancer of the breast, liver, kidney, and eye as well as in observing mitral valve motion and shifts of the midline of the brain. However, a definite need exists for a new device which can convert the ultrasonic energy into visual information, for conventional ultrasonic viewing as well as ultrasonic holography viewing.
- ° Another important area where a need exists for unexploited physical phenomena is in cardiac output measurement. The heart is basically a pump, and the blood output requires precise measurement. Although several methods have been tried, an innovative approach to this problem is needed.
- ° Another significant problem is in the detection of deep-seated cancer. Cancer at the present time has a good chance of cure if it is detected early enough, most cures being effected on superficial cancers such as skin, breast, and cervical. However, for deep-seated cancers such

as in the lung and stomach, the cancer has usually advanced too far for successful treatment by the time it is detected.

- ° Another difficult problem concerns the measurement of pleural pressure or the pressure in the pleural cavity surrounding the lungs. In a normal person, this cavity is generally not filled, but certain diseases cause the cavity to begin filling. There is a need for a noninvasive method of measuring this pleural pressure with precision.
- ° One of the most common measurements made in medicine today is blood pressure, yet significant improvements need to be made for patient monitoring. The conventional noninvasive method of measuring blood pressure requires that a cuff be inflated around the arm, but this occlusive cuff technique clearly is unsuitable for long-term monitoring of a critically ill patient. Although a number of ingenious approaches have been made in new methods of blood pressure detection, a desperate need still exists for a noninvasive blood pressure transducer which does not significantly disturb the patient.
- ° Another very common measurement in patient monitoring is chemical analysis of body fluids such as urine and blood. There is a need for an on-line device to measure constituents of the blood such as sugar, lactates, and pyruvates as well as a need for a device for rapid analytical urine measurement. For on-line measurements, significant breakthroughs will require new approaches such as the recent use of mass spectrometers.
- ° Another need for the use of unexploited physical science phenomena in transducer design is in the area of detecting atherosclerosis. This disease is one of the major causes of death in this country, and detection of the deposits which characterize the disease are a significant problem. New methods of detection are needed--particularly by noninvasive methods.

Development of Unutilized Physiological Phenomena

The third major class of transducer improvement is the need for utilization of new physiological phenomena--particularly in the area of patient monitoring. An overemphasis has been placed on monitoring temperature, pulse, respiration, and blood pressure instead of the useful information that the physician now obtains by personal observation. Proof of this overemphasis on



Figure 1. Two Patients Following Open-Heart Surgery (After Maloney).

monitoring can be seen in a simple example: Suppose a patient who had the usual transducers attached to him fell out of bed and was knocked unconscious. The variables that were being monitored would still fall within normal limits and a nurse at a central station would not detect the fact that her patient was lying on the floor unconscious. Although the purpose of monitoring is not merely to detect falling patients, this example does graphically illustrate the fact that monitoring the easy variables is clearly insufficient.

Dr. James V. Maloney, Chief of Thoracic Surgery at the UCLA School of Medicine, recently addressed this very point by saying, "As I approach the bedside as a clinician, despite my interest in computers, monitoring, and physical sciences in general, 95 percent of the useful information that I obtain in evaluating the patient comes from talking with him, seeing him, smelling him, and feeling him. One of the last things I ask for is a graphic chart that presents temperature, pulse, respiration, and blood pressure."¹ His observation demonstrates that the brain of the physician is able to integrate considerable information which existing transducers do not detect.

One key factor in this detection process is pattern recognition. For example, the pattern recognition capabilities of any physician would enable him to predict that of the two patients in Figure 1, the patient on the left was going to die, and the one on the right was going to survive--despite the

fact that the four channels of analogue data on both patients look quite normal. How do we recognize the nature of the patient's condition on the left despite the normal physiological data? Actually, we do not know, but at some future time when the cognitive processes are understood, it will be possible to design a meaningful monitoring system.

Many examples of this class of transducer could be given, but these three will illustrate:

- ° One example of the need for use of new physiological phenomena in monitoring concerns the ability of a trained physician to easily detect some things that a transducer cannot. Many physicians who have worked in a large city hospital have experienced the situation in which six or eight individuals were in the emergency room with gunshot or knife wounds--some minor and some serious. At a glance, a trained physician can tell those who are hypoxemic, those who are anemic, and those who are in shock. He can diagnose these conditions even though there is a dark melanin pigment in the skin of Negro patients. Obviously, the physician has learned something that enables him to quickly detect the patient's condition, but no transducers are available which can do this. It is not desirable to simply duplicate the physician's ability, but this example points out the fact that valuable physiological phenomena are not being utilized in detecting a patient's condition.
- ° Another example of this need is in the quest for cellular information. Medical research is probing deeper and deeper into the fundamental processes that occur in the human body. A common need in this quest is a method of measuring pressure within a single human cell. It is fairly certain that a new concept in transducing that utilizes a different physiological phenomenon is needed in order to detect this pressure.
- ° Another example which was mentioned earlier is the need for a means of detecting deep-seated cancers. This detection requirement is so significant that not only should unexploited physical science phenomena be used, but the utilization of some different physiological characteristics of the tumor will probably also be necessary. These

might include the presence of calcium in the tumor or perhaps the difference in electrical properties of the cancerous and normal cells.

CONCLUSION

In summary there are three major classes of transducer improvements required: improvements in existing transducers, needs for unexploited physical science phenomena in transducer design, and needs for unutilized physiological phenomena in transducer design. During the next decade, increasing emphasis will be placed on noninvasive measurement in all of these areas. Patient safety, patient comfort, and the need for efficient utilization of the time of both patient and physician requires that noninvasive methods of monitoring be developed.

Regardless of one's goals, the new requirements for transducers during the next decade will offer significant opportunities and challenges. This is true whether the goal is the altruistic one of improving health care or a more economically oriented goal of new product opportunities. Success in either of these areas will come only when the medical-engineering team working together decides that should be done as opposed to what can be done most easily.

REFERENCE

1. Engineering and Medicine, National Academy of Engineering, 1970.
2. J. V. Maloney, Annals of Surgery. 168, 610 (1968).

APPENDIX D

INTERDISCIPLINARY BARRIERS - AN IMPEDIMENT TO
THE EFFECTIVE APPLICATION OF SYSTEMS ENGINEERING

*(Paper presented at the 1971 Annual Conference of the American
Occupational Therapy Association, Cleveland, Ohio, November 1,
1971)*

INTERDISCIPLINARY BARRIERS - AN IMPEDIMENT TO
THE EFFECTIVE APPLICATION OF SYSTEMS ENGINEERING

by

Ernest Harrison, Jr.

Presented at the

AMERICAN OCCUPATIONAL THERAPY ASSOCIATION
1971 ANNUAL CONFERENCE

November 1, 1971

This work supported under Contract #NASW-2273

by

National Aeronautics and Space Administration

INTERDISCIPLINARY BARRIERS - AN IMPEDIMENT TO
THE EFFECTIVE APPLICATION OF SYSTEMS ENGINEERING

ABSTRACT

The necessity of including information and technology from multiple disciplines when invoking the principles of systems engineering or systems analysis for the study of large scale problems is implicit and widely recognized. Interdisciplinary transfer of information and technology does not, however, occur very readily, even for system planners, because of the existence of some very real barriers. These barriers to flow of information and technology between disciplines represent one of the important difficulties associated with the application of systems analysis to many problems. The nature and characteristics of some of these barriers are enumerated and discussed in detail. A number of methodologies and techniques which have been specifically developed to aid in the transfer of technology and information across these interdisciplinary barriers is examined. These techniques and methodologies are evaluated to determine their applicability to several classes of problems involving various levels of effort.

INTERDISCIPLINARY BARRIERS - AN IMPEDIMENT TO
THE EFFECTIVE APPLICATION OF SYSTEMS ENGINEERING

1. INTRODUCTION

Systems engineering has proved to be a startlingly effective tool for the accomplishment of complex, large-scale objectives in the physical sciences and engineering. Many difficult problems have yielded to solution using these techniques. Perhaps the most outstanding example of the success of this technique is the United States Space Program which had as its objective the manned exploration of the lunar surface. The success of systems engineering as a methodology for accomplishing difficult objectives has resulted in efforts to extend its use to problems of widely varying composition and scope.

Indeed, the growth (in number and subject matter) of applications of systems engineering has resulted in a certain blurring, especially to the "public-at-large," of just precisely what systems engineering is. Consequently, in order to provide a basis for discussion, it may be worthwhile to look at some of the words that various people use when discussing this area.

2. BACKGROUND

2.1. Systems Terms. First, consider the term "system." Cleland and King¹ in their textbook have defined system as "an organized or complex whole; an assemblage or combination of things or parts forming a complex or unitary whole." Baker² in a survey of systems and medical care quotes several other definitions of system as: "the totality of objects together with their mutual interactions," "unity consisting in mutually interacting

parts," and "a recognizably delimited aggregate of dynamic elements that are in some way interconnected and interdependent and that continue to operate together according to certain laws and in such a way as to produce some characteristic total effect."

In addition, various kinds of systems have been assigned classifications; for example, a system is classified as open or closed depending upon whether material enters or leaves the system. A system is open if there is import and export with respect to the system. It is, of course, obvious that living organisms are examples of open systems. It has been pointed out³ that most organisms are quasi-stationary open systems. For example, metabolism is essentially a process concerned with maintenance of a steady state.

2.2. Systems Engineering Terms. In defining the term systems engineering, it is perhaps first wise to recognize that there are at least two other terms which are used to denote the activities that can be described under systems engineering. They are "systems approach" and "systems analysis". In defining systems engineering, we should keep in mind that the definition applies more or less precisely to all of these related terms as well. Rabow⁴ has said that the systems approach is basically the looking at a problem from the overall viewpoint and dividing it into a set of smaller problems which, when solved together, solve the original problem.

Cleland and King⁵ point out that, in essence, systems analysis is a methodology for analyzing and solving problems by systematic examination and comparison of alternatives on the basis of resource cost and benefit associated with each. In such an analysis, explicit consideration is given to the uncertainties involved in decisions which will be implemented in the future. Ramo⁶ has said that the systems approach, as a basic

requirement, employs an interdisciplinary team representing both the technological and nontechnological aspects of the problem to be analyzed. He points out that one of the most frequent incorrect assumptions concerning the systems approach is that highly specialized, narrow-disciplined engineers who are skillful in the details of technology but with no knowledge of the people and workings of our social systems are brought in to revolutionize these systems. This misconception has as its basis the idea that there is a pure technological solution for every problem.

This concept of the systems approach, however, is completely false. In a problem involving people, it is obviously of great importance that nontechnologists, i.e., social scientists, etc. be members of the team involved in the systems analysis effort. Particularly in the definition of system requirements, the nontechnologist may have the most valuable inputs to any concerted systems engineering approach. Finally, English⁷ quotes the definition of systems engineering from the Defense Department Systems Engineering Management Procedures AFSCM375-5, "Systems engineering is fundamentally concerned with deriving a coherent total system design to achieve stated objectives. No two systems are ever alike in their developmental requirements. However, there is a uniform and identifiable process for logically arriving at systems decisions regardless of system purpose, size, or complexity."

Many have asked the question as to whether systems engineering might not actually sound just like good ordinary engineering or maybe even just good common sense. There is certainly an element of truth in such a conclusion--especially when applied to small, uncomplicated systems.

Dr. Simon Ramo⁸ has asked if the systems approach is really "no more than just doing things right as against doing them wrong, being intelligent rather than stupid, being objective rather than irrational in approaching

problems." We would again have to answer that the systems approach, in its most general sense, seeks to bring to bear on the problem every discipline and profession which possesses information or experience pertinent to the solution of the problem. This then requires the premediated use of experience and talent, as well as disciplinary tools, of all of the individuals who can contribute to a solution of the problem. The systems approach is, by definition, objective and logical. It seeks to bring to bear all facts pertinent to the solution of a problem. It is this necessity for bringing together all facts pertinent to the problem that requires a competent interdisciplinary team.

2.3. Limitations to Systems Engineering. What are the limitations to systems engineering? First, there are obviously some systems that are so big and complex that one cannot apply an overall system analysis. It is apparent, however, that benefit can still be derived by isolating portions of these large systems and working on these smaller problems with the systems engineering approach. On the other hand, some problems are sufficiently small that a full-scale systems engineering effort cannot be justified. It is, in fact, the possibility of using some elements of the systems approach on relatively small problems, as opposed to problems involving large systems such as hospitals and larger elements of the health care system, that I wish to explore. In essence, I would like to look at the level of problems which might be encountered by the individual therapist within his or her own institution and to explore the means whereby one might apply a modified systems engineering approach or at least some of the concepts of the systems approach to these problems.

It certainly isn't inconceivable that a therapist may encounter a problem in which the skills and experience of mechanical engineers, electrical engineers, materials specialists, and various medical specialists might all

be required. I am well aware that many are not in a position to purchase the multidisciplinary talent that would be required to set up a systems engineering team to attack such a problem. Must we then conclude that the average individual therapist cannot avail himself of the benefits to be obtained by the application of the systems approach? Certainly, when funding is a significant problem, one cannot employ the full-scale interdisciplinary team that is characteristic of the classic systems approach. The question then is whether or not there are other available resources which might permit the acquisition of more interdisciplinary data on the problem than can be marshalled out of the individual therapist's own experience.

Actually, the presence of people is not what one is necessarily seeking in a systems effort. What is desired is the information from other disciplines that these people can bring to bear on the problem. Now if one cannot afford to bring together such a multidisciplinary team and yet the experience and information from these fields is still necessary, then one must ask the question: "How can information from these fields be obtained?" In reality, the transfer of information and technology from one discipline to another is an extremely slow and laborious process under most circumstances. Still, if information from these other disciplines is necessary to an optimal solution of the problem, then the information must be obtained if one is to maintain any semblance of using the systems approach.

3. BARRIERS TO TRANSFER OF INFORMATION AND TECHNOLOGY

3.1. General. In many problems that we encounter, pertinent technology and information are indeed in existence in the various disciplines. The difficulty is obtaining the information and applying it to the problem. Some of this diffusion of knowledge does take place under the right circumstances. But, it has been apparent for some time that the movement of technology and knowledge from the engineering and physical sciences into the medical field

is a process that does not occur spontaneously. Many who have investigated the interaction between modern technology and medicine have recognized and catalogued a variety of barriers which impede this interaction.

Recognizing that there is a significant backlog of technology already developed by the physical sciences and engineering community which may have application to medicine, let's look at some of the barriers to diffusion of this knowledge from the technological community into the medical community. Then, we will consider in some detail several methodologies and techniques which have been specifically developed to aid in the transfer of technology and information across these barriers.

Assume you have a problem which requires informational or technological input from another discipline for its solution. There are at least two ways of obtaining such information or technology. First, obviously, research and development can be undertaken with an engineering and scientific team or staff to generate the new technology required. Second, advanced technology might be transferred from other fields or disciplines. The latter can be much less expensive provided: (1) the technology already exists somewhere, (2) the required technology can be identified, and (3) the technology can be transferred, that is, modified for effective utilization.

3.2. Why Transfer Is Attractive. What are the factors that make the transfer of technology and information from one field to another attractive?

- (1) There has been an extremely large expenditure of funds both privately and by the government on research and development programs and application programs involving advanced technology. If multiple uses for this technology can be found, it will increase the return on the investment dollar.
- (2) Because of the large amounts of money spent on advanced technology in these various programs, there is a large technology base or reservoir from which applicable technology can be sought.

- (3) Advanced methods of searching for technology (e.g., computer searching of entire fields of learning very rapidly) have made the task of looking for specific problem solutions within the technology reservoir easier.

3.3 The Barriers. Some barriers to interdisciplinary information and technology transfer are given in Table 1.

Table 1 - BARRIERS TO TRANSFER

- (1) Compartmentalization of knowledge and technology within discrete specialized fields.
- (2) Language barriers.
- (3) Size of the technology reservoir.
- (4) Organizational (structural).
- (5) The "not-invented-here" syndrome.
- (6) Resistance to novel solutions.
- (7) Alienation of administrators and scientists.
- (8) Treachery of written material.

Considering these in order:

- (1) Compartmentalization of knowledge and technology within discrete specialized fields. The increasing specialization of scientists and engineers has reduced the probability of contact with those outside their specific disciplines. The state-of-the-art in many specialized disciplines is advancing so rapidly that individuals frequently have no time for anything but pursuit of their own specialization. This has led to compartmentalization of knowledge and technology so that other scientists and engineers outside a

particular specialty know little about advances in technology within that specialty field. Boulding⁹ calls this specialization process "specialized deafness" and defines it to mean "that someone who ought to know something that someone else knows isn't able to find it for lack of generalized ears." He points out that one of the crises of science today arises because of the increasing difficulty of profitable talk among scientists as a whole.

- (2) Language barriers. Concurrent with the specialization which has taken place within the scientific and engineering disciplines has been the growth of a disciplinary jargon or specialized language which requires membership in the discipline in order to be intelligible. This results because generalized language is too unwieldy or nonspecific to permit description of the precise meanings demanded by specialization. In many cases, the new language is invented concurrently with new discoveries by specialists in their fields. Finally, most specialists interact only with peer groups, that is, they only talk to each other. Consequently, there is little impetus for the language developed within each specialty to be utilitarian in structure or to be intelligible to those outside the group.
- (3) Size of the technology reservoir. There is no question that we are in the throes of an information and technological explosion. Burgeoning growth of technology and information has caused the technology reservoir to become so large that an attempt to locate a specific item of technology in this reservoir has become a formidable task. The size of the technology reservoir actually has two effects.
 - (A) The larger the reservoir, the higher the probability that a solution exists in the reservoir.
 - (B) By the same token, the larger the reservoir, the more difficult it is to find or identify a

solution that exists in the reservoir and, perhaps more important, the greater the difficulty of even establishing the existence of a solution.

It is this increasing amount of time and effort required to establish the existence of applicable technology within the reservoir (to search the reservoir) which has caused large numbers of people to despair of this approach and instead invest their time and funds in a development program to produce the required technology. The history of modern-day technology is replete with examples of this "re-invention of the wheel." It is certainly justifiable to "re-invent the wheel" any time that the cost of determining whether or not someone else has already invented the wheel becomes a significant portion of the investment required for re-invention.

There is, in addition, a more subtle consideration which affects the choice of whether or not to search the reservoir before undertaking to develop the required technology. Generally, applicable technology found in another field must be modified (re-engineered) to permit it to function effectively under the constraints of use in the new discipline. This re-engineering must be done, and someone must pay for it. The cost of re-engineering varies over a rather wide range depending upon the degree to which the capabilities of the technology match the requirements of the intended application. The net result of these factors is that unless the problem is extremely difficult and development of the technology "from scratch" is very expensive, most people will choose to "re-invent the wheel."

- (4) Organizational (structural). Sometimes the barriers to technology and information transfer are structural in nature. For example,

the experiences of industry are replete with instances of people inventing the same thing in different departments within the same organization, or perhaps even worse, of someone requiring technology which is well-known in one department but unavailable in the department which needs the technology. When departmental lines are strongly drawn with little interchange between departments, structural barriers are frequent within organizations.

- (5) The "not-invented-here" syndrome. There is sometimes very powerful resistance to seeking information or technology from outside. While a seemingly foolish barrier, it is, nevertheless, a very powerful factor in many situations and sometimes completely overrides all other considerations.
- (6) Resistance to novel solutions. Novel solutions are sometimes not associated with the problem for which they are a potential solution and thus difficult to recognize. In addition, there is a tendency to reject novel solutions out-of-hand. Black¹⁰ points out that if one undertakes "an adequate, serious, open-minded analysis of an unusual approach, it is often annoying, emotionally disturbing, and hard work."
- (7) Alienation of administrators and scientists. Administrators are frequently in a position to perform a coordinating function between disciplines but are sometimes prevented by hostility and friction between scientists and administrators.
- (8) Treachery of written material. It has been amply illustrated that transfer of technology by means of written material is very difficult. This is a well-known and widely documented fact. Many who have attempted to obtain information or technology from a "foreign" discipline by means of written communication (for example, journal

articles) have discovered how difficult such a procedure really is. In most cases a telephone call or visit to the author is eventually required to obtain all the information needed for implementation of technology.

4. ATTEMPTS TO REDUCE THE BARRIERS

A number of techniques have been employed in an attempt to overcome these barriers. Some of these are listed in Table 2 and discussed in the following paragraphs.

Table 2 - METHODS OF REDUCING THE BARRIERS

- (1) Systems Engineering Team.
- (2) Multidiscipline people.
- (3) People transfer.
- (4) Computerized information searches.
- (5) Experimental technology transfer programs.

4.1. Systems Engineering Team. The multidisciplinary systems engineering team employed in the systems approach is obviously a large-scale attempt to overcome the interdisciplinary barriers to technology transfer. It takes account of a fact, to be discussed later, that interdisciplinary barriers are rendered significantly less effective when person-to-person contact between disciplines is possible. By bringing together representatives of all of the disciplines which can contribute to a problem, communication between those individuals is greatly enhanced, resulting in transfer of information and technology between disciplines. This answer is, of course, the classic answer of systems engineering.

4.2. Multidiscipline People. There has been a relatively new development, within the past 10 to 20 years, which has as its objective the bridging of the gap between disciplines; namely, the training within our universities of multidiscipline people. This development has occurred in a number of fields, including medicine. Examples of intermarriage of such disciplines can be readily found; for example, biochemistry, biophysics, and in more recent times we have seen the development of biomedical engineers and biomechanical engineers. These people receive training in two disciplines, usually a field of medicine and a technical specialty. The objective of this type of training is to produce an individual who can communicate with the medical field and yet can bring to bear technology from the physical and engineering sciences. There has been a significant amount of debate concerning the type of training that such individuals should receive. In fact, there has even been debate as to what kind of people these disciplines represent.

For example, in 1968, Tichauer and Glaser¹¹ conducted a survey of the needs of engineering schools in the field of biomechanical and human factors education. One hundred sixty-seven engineering schools were canvassed by two surveys. One of the questions asked was: "How do you define biomedical engineering?" The answers varied from genuine attempts to answer the question to such comments as "There are ten different ways to define it" or "I don't define it at all" or "I wouldn't use the word." There is still something of an identity crisis concerning who or what the biomedical engineer is. The desire, however, to bring about the application of physical science and engineering techniques in the field of medicine is sufficiently strong that there appears to be continuing interest in the field of biomedical engineering.

4.3 People Transfer. Another method of transferring information across disciplinary or organizational boundaries is to transfer people possessing the information. This is a variation of the person who is trained in two disciplines. However, in this case, the individual is not necessarily trained in the second discipline into which he is thrust either by choice or circumstances. Usually, he brings a background of one discipline to a new job. In this case, the individual must essentially master the new field on his own. Still, there are numerous examples of the transfer of technology by the process of transferring people. Danhof¹² published a study of technology transfer by people transfer in 1969. In this study, he requested information from 352 former National Aeronautics and Space Administration employees who had accepted employment in other organizations. Of those who responded, 47% indicated that they had transferred NASA-generated technology to their new employers, and 95% indicated that they expected at some future time to transfer technical knowledge derived from their experience to their new employers.

In this study, the respondents were divided into two groups: those whose new employment was essentially the same as their NASA employment and those in which employment was substantially different. Only 33% of those having essentially the same employment reported transferring NASA technology. On the other hand, 67% of those with substantially different employment reported transfers. Thus, the frequency of technology transfer was notably higher when the new position was substantially different from the old position at NASA. From these studies, Danhof concluded (1) that when people are transferred under proper circumstances, the probability of technology transfer is high and, (2) that changes in employment and work circumstances are associated with high rates of technology transfer.

4.4. Computerized Information Searches. Although it is recognized that the transfer of documents such as journal articles, etc. between fields is not a very effective manner of transferring technology (it has already been listed as a barrier), it must be recognized that this is frequently the first step leading to the identification of technology which has the potential for transfer. As a result, improved techniques for searching the literature of various fields has some significance as an aid in overcoming interdisciplinary barriers. The development within the past 10 to 15 years of computerized information banks has made it significantly easier for the individual to locate documents pertinent to a given area. These computerized information sources are generally organized on keyword bases so that, by selecting a proper set of key words or descriptors, only those documents indexed under the particular set of descriptors will be selected by the computer from the entire document file.

4.5. Experimental Technology Transfer Programs. The idea of transferring technology between disciplines is essentially the concept of applying technology and information developed by one individual or group for a specific purpose to another individual or group for a secondary purpose. It has been apparent to those who have studied the processes of technology transfer that if technology transfer is allowed to proceed at its own pace, then transfer between disciplines occurs very slowly and in a random manner. Between 1958 and 1968, approximately 100 billion dollars were spent on research and development. Of that amount, approximately two-thirds was government funds. Because of this fact, the government has a strong interest in finding multiple uses for technology developed within its various supported programs. Indeed, if one is to obtain full value for the research and development dollar, then these secondary applications of technology must be

accomplished. As a consequence, there have been a number of studies and experimental programs funded by the government to explore the methodology of technology transfer and to seek to find means of enhancing the probability that new technology will find its way into second uses.

It can be quickly recognized that one of the most significant problems is the fact that these barriers exist and there are few channels available for the flow of information, ideas, and technology between the disciplines. In an attempt to create effective avenues for the flow of technology and information between disciplines, several methodologies have been explored. One example is an experimental program undertaken by the National Aeronautics and Space Administration to attempt to find ways of transferring technology from the aerospace field into the biomedical field. This experimental program, called the Biomedical Application Team Program, has been in existence for approximately five years. It was immediately apparent that the ordinary method of transferring technology employed in the past was essentially passive. For example, articles were published in journals, and anyone interested could read the journal. If not, they remained unaware of the technology. Essentially, information is available in printed form, and if one wishes to use this information he must seek it and locate it in order to use it. The difference between the Application Team Program and conventional methodology is that the Application Team method actively seeks to establish channels for the flow of information and technology. Essentially, an agent (the Team) is introduced between the disciplines in order to act as a channel for the flow of ideas.

The Application Teams consist of interdisciplinary teams of physical scientists that attempt to interface between individual researchers in medicine and technology originators in the aerospace field. In this program, the Team members seek out specific biomedical problems which are impeding the work of

biomedical researchers and then actively seek solutions to these problems. The problems identified by the Team are defined in precise language by the medical researcher and the Team member.

Following problem definition, solutions to the problem are sought within the aerospace complex. Searching for solutions is accomplished using several approaches. First, a computerized information searching service is employed to perform computer searches of the NASA document bank in the specific area of the problem. Although information obtained from the NASA document file has not been the primary means whereby technology has been transferred, searching of the NASA document files has nevertheless performed one very important function in a number of cases. It has frequently permitted the Team to identify engineering and physical scientists within NASA who are working in areas related to the solution of the problem. This identification procedure has then made it possible to contact the NASA researchers directly and bring to bear the expertise of these researchers in personal interaction with the medical researcher.

Another approach used in searching for solutions is to request suggestions from NASA personnel by circulating to the nine NASA research centers concise written statements of the individual problems. Circulation is accomplished at each research center by a Technology Utilization Officer who has a detailed knowledge of the research activities at his research center. Suggestions received are relayed to the medical researcher for evaluation. If suggestions appear pertinent to the solution of the problem, then efforts are made by the Team to produce effective interaction between the medical researcher and the NASA researcher to solve the problem. It has been found that personal interaction between knowledgeable medical researcher and knowledgeable physical scientist possessing information pertinent to the solution of the researcher's

problem has been the most effective manner of producing technology transfer. The program thus provides information to medical researchers from fields that they would not normally contact. Once solutions to the problem have been obtained that are acceptable to the medical researcher, the Team acts as a catalyst to aid in implementation of these ideas. The primary responsibility for implementation of the technology lies with the medical researcher; however, the Applications Team assists in engineering consultation and in recommendations for ways of applying the technology.

Examination of this program shows that some of the elements of a biomedical systems engineering team are present including: (1) the inputs consisting of the definition of the problem and problem requirements given by the medical researcher, (2) the expertise of the interdisciplinary team within the various disciplines of engineering, (3) the use of the computerized information processing system to identify sources of technology, and (4) perhaps the most significant aspect of the program, the person-to-person contact.

4.7. Comments. The effects of specialization, language barriers, size of the information reservoir, and difficulty of transfer by the written word can all be reduced by the techniques just discussed. The other barriers discussed (organizational, alienation of scientists and administrators, resistance to novel solutions, and the "not-invented-here" syndrome) tend to be individual problems peculiar to certain organizations and types of people. Advice on people problems is beyond the scope of this paper.

However, one comment on organizational barriers may be appropriate. When organizational structure is a barrier, perhaps the most important action that can be taken is to recognize it. If there are no people problems or political problems present, then recognition that the barrier exists and

appreciation of its undesirability are usually sufficient catalyst to bring into being forces within the administration desiring to eliminate the problem. In some cases, recognition may occur but the problem may be judged of secondary importance, i.e., subordinate to other primary (and conflicting) requirements imposed on the organization, so that no benefit is realized from recognition of the problem. It does appear, however, that in many cases organizational barriers are allowed to continue to exist primarily because we are not aware of their presence. I might add that these comments on the organization are perhaps more applicable to industrial organizations than to organizational structures within the medical field.

5. INTERDISCIPLINARY RESOURCES AVAILABLE TO THE INDIVIDUAL RESEARCHER

It would be unfair to enumerate the barriers without suggesting some ways in which they may be circumvented. Certainly, because of the cost of a systems engineering team, individual therapists cannot usually employ the full-blown, classic systems approach. On the other hand, there are resources available to the average therapist which may supply a broader input of interdisciplinary data to the solution of the problem than is likely to be present within the experience of the individual therapist. From a practical standpoint, then, it would perhaps be wise to look at some of these resources which are available. The use of these resources will not transform an individual's efforts into systems engineering; yet, the broadening of one's information base cannot be other than beneficial in the solution of problems. What are these resources? There are at least three classes of resources:

- (1) Documentary.
- (2) Commercially available technology.
- (3) Research and development assistance (location and identification of technology).

Under the documentary resources, the most obvious is journal articles. The limitations of journal articles and written material in general have already been discussed; however, journals are definitely not passé. They still represent an important information resource, and for most areas, they represent a locally available resource--particularly, provided a university library is nearby. Admittedly, this resource is difficult and time-consuming to use, but if one has the time available, it can be a very useful source of information.

There are a number of federally supported information analysis centers located in various sections of the country that have as their primary function the collection of information in specific subject areas. These information centers generally provide thorough coverage of particular topic areas and can prove extremely useful. The Committee on Scientific and Technical Information of the Federal Council for Science and Technology has compiled a "Directory of Federally Supported Information Analysis Centers." This directory lists the services available and the scope of information residing within each center. This document is available from the National Technical Information Service of the U. S. Department of Commerce.

Another useful information resource is the "Directory of Information Resources in the United States" published by the National Referral Center for Science and Technology and available from the Superintendent of Documents of the U. S. Government Printing Office in Washington, D. C. This directory is devoted primarily to information resources in the physical sciences, biological sciences, and engineering.

Another very useful collection of information resources may be found in the "Encyclopedia of Information Systems and Services" published by Edwards Brothers, Ann Arbor, Michigan.

For international information systems, the "Inventory of Major Information Systems and Services in Science and Technology" is published by the Organization for Economic Cooperation and Development, Paris, France. This publication is available from the National Technical Information Service of the U. S. Department of Commerce. In seeking out these specialized information resources, your best ally is a good reference librarian.

While not attempting to catalogue all of the available computerized information resources, there are several which may be useful. First, there is one which I am sure that most people in the health care field are familiar with; namely, the MEDLARS information service. This service is provided by the National Library of Medicine of the Department of Health, Education, and Welfare, Public Health Service, in Bethesda, Maryland. The key words are primarily medical terms, and information residing in the information bank consists, in large measure, of excerpts from medical journals and related medical literature. Searches of the MEDLARS system can usually be obtained from libraries associated with medical universities. In addition, individual inquiries made directly by mail are also accepted by MEDLARS.

Second, the Engineering Index and the Chemical Abstracts are widely used resources in the fields of engineering and material science. These resources are published as abstracts on a periodic basis and are usually available in most large libraries. In addition to the abstracts, however, both of these services have also placed their abstract information on tapes so that computer processing can be used to abstract documents according to key word indices. Unfortunately, neither of these resources themselves provide a searching service. Instead, they provide magnetic tapes to user institutions. Many large firms have the tapes available and use them for information searching purposes. In addition, these tapes are available from some university computing centers.

Third, the NASA Regional Dissemination Centers provide computer searching of a variety of materials. The primary data base for the Regional Dissemination Centers is the NASA Aerospace Literature File. In addition, many of these centers include the Engineering Index tapes, the Chemical Abstracts tapes, the unclassified Department of Defense file, plus a variety of other smaller files on specialized subjects. There are six of these NASA Regional Dissemination Centers distributed across the United States so that in all likelihood, there is one at least in your general area.

In the area of commercially available technology there are a number of publications which can be of value in determining whether or not required technology is commercially available. The American Association for the Advancement of Science publishes a "Guide to Scientific Instruments" each year which can be an aid in locating manufacturers of general scientific equipment. The "Thomas Register," available in most libraries, is a very general file which lists manufactured items by category so that one can determine the available suppliers of specific categories of equipment. A similar publication, yet specific to the electrical engineering field, is the "Electronic Engineers Master." This volume, also published yearly, lists the various categories of electronic equipment and instrumentation along with the manufacturers of the listed equipment. It, too, is available at many libraries.

The American Institute of Biological Sciences, Bioinstrumentation Advisory Council in Washington, D. C., publishes a number of information modules detailing equipment sources for specialized areas and provides advice on equipment selection. In the specific field of medical instruments, the Medical Electronics News, a periodical, publishes a yearly "Dictionary and Buyer's Guide Issue" which is a useful index of medical equipment suppliers.

Another source of information on currently available equipment which is so common that one scarcely needs to mention it is the manufacturers' representatives

and salesmen. It must be admitted that manufacturers' representatives on occasion are a source of annoyance, taking up time which one might rather spend elsewhere, and also, that they cannot be depended upon to supply completely unbiased evaluations of the equipment which they happen to be representing. Nevertheless, they do indeed form a part of the information network. In this connection, we have discovered that the smaller companies are frequently quite helpful, particularly, when a specialized fabrication source is required (i.e., when a device is not currently available but is within the current state of the engineering art). Such small companies are located in almost every metropolitan area. They are frequently more responsive to individual needs and are quite often eager to help.

One of the problems to be faced in getting a specialized device fabricated is the problem of ensuring that the equipment, once it has been built, satisfies the particular application. When one contracts with an engineering organization to build a particular device to accomplish a particular purpose and when the resulting equipment does not accomplish that purpose, the fault can usually be traced to poor communications. The engineer does not understand the medical problem, and perhaps the medical researcher does not understand the engineering problem. We have found that it is very important not only to tell engineers the requirements or specifications of the equipment, but also to make sure that the engineer understands how the equipment is to be used and what other equipment is involved. There are often implicit assumptions made both by the engineer and by the medical personnel, which neither is aware that the other is making. A thorough discussion of the use to which the technology is to be put can frequently reveal these implicit assumptions with a considerable savings of time and cost.

The final category I have called "research and development assistance" or location and identification of new information and technology. There is one

resource in this particular category which we (because it is so obvious) frequently neglect. I am speaking, of course, of one's own organization. If information or technology exists within the organization, the likelihood of obtaining direct and immediate assistance with problems is generally much higher within one's organization than from any other resource. If one requires new technology or information from outside his own field, the time required to become familiar with the activities going on within one's own organization is usually time most profitably spent. Obviously, this comment is more appropriate to larger organizations than to smaller ones.

There is a growing awareness especially among young people that technology should be contributing to social needs. Many schools of engineering are very receptive to cooperative projects and programs to develop specialized instrumentation or to apply new technology to the medical field. In most universities graduate students are frequently looking for thesis and dissertation topics which have some impact in the social area. In many of the engineering schools, professors have found that practical class projects in which an actual problem is solved by the class are significantly more valuable than routine laboratory exercises. This can be an extremely effective method for interaction between medicine and engineering. It also happens to be an area in which the medical researcher, limited by funds, can frequently participate since engineering schools are sometimes willing to furnish these services without charge.

Finally, I do not feel that I can close without mentioning again the resource represented by the experimental NASA Biomedical Application Team Program discussed earlier. Each Biomedical Application Team (there are presently three teams) is a multidisciplinary team of physical scientists and engineers.

The teams actively seek to promote the transfer of information and technology by direct person-to-person contact with individual medical researchers. The teams seek to identify problems which fit certain criteria (these criteria are imposed to eliminate problems with low transfer probability). The criteria are: (1) The problems must have no solutions available on the commercial market. (2) They must be discrete and must be defined in specific terms. (3) They must impede the progress of priority efforts of the researcher, and (4) they must, of course, appear amenable to solution by aerospace-related technology. I would like to quickly point out that this last requirement is not so restrictive as it may seem on the surface. Because of the extremely broad scope of disciplinary coverage provided in the NASA aerospace program and the resulting development of expertise in such a wide variety of disciplines, there are few problems which can quickly be rejected by this criterion. While the overall mode of operation of the teams is to work with certain specified medical schools and centers, the teams do respond to individual requests which are received. Consequently, this resource is available to the individual, within the constraints of the problem selection criteria.

6. CONCLUSIONS

In conclusion, although some have, in criticism, implied that the systems approach on small problems is only good common sense, I have tried to make the point that it is a very special kind of common sense. It is an informed common sense. Systems analysis is at its best when all of the available information pertinent to the particular problem can be marshalled, evaluated, and the optimum solution selected by objective processes. When one must make decisions without benefit of full information then he is practicing, at the minimum, a restricted kind of systems analysis. Emphasis, in this paper, has

been placed on modified or imperfect systems analysis, i.e. when not all of the available information can be obtained. Surely one must conclude that even though all the available information pertinent to the solution of a problem cannot be obtained within the constraints imposed by an individual's particular situation, the use of those information resources which are available will result in better solutions than if the information is not utilized. Essentially, even though one may not be able to practice the full-blown classical systems approach, this fact should not be a deterrent to use of all of the resources which can be brought to bear on a specific problem. Stated in its simplest form, common sense, reinforced by valid information, is far superior to common sense alone.

- (1) D. I. Cleland, W.R. King, "Systems Analysis and Project Management", p. 10, McGraw-Hill Book Co., N. Y. 1968.
- (2) F. Baker, C. P. McLaughlin, A. Sheldon, "Systems and Medical Care", p. 4, MIT Press, Cambridge, Mass., 1970.
- (3) L. von Bertalanffy, "The Theory of Open Systems in Physics and Biology", Science, Vol. 111, (Jan. 13, 1950), p. 23.
- (4) G. Rabow, "The Era of the System", Philosophical Library, p. 59, N. Y., 1969.
- (5) Cleland and King, op. cit. p. 23.
- (6) S. Ramo, "Cure for Chaos", p. vi, David McKay Company, Inc., New York, 1969.
- (7) "Cost Effectiveness", J. M. English, Editor, p. 11, J. Wiley and Sons, New York, 1968.
- (8) Ramo, op. cit., p. viii.
- (9) K. E. Boulding, "General Systems Theory - The Skeleton of Science", p. 198, Management Science, V. 2, #3, April 1956.
- (10) G. Black, "The Application of Systems Analysis to Governmental Operations", p.35, F. A. Praeger, New York, 1968.
- (11) A. A. Glaser and E. R. Tichauer, "Two Surveys of the Needs of Engineering Schools in the Field of Biomechanical and Human Factors Engineering Education", p. 25, June 1968, Washington, D. C. United States Government Printing Office.
- (12) C. H. Danhof, "Technology Transfer by People Transfer : A Case Study", August 1969, National Technical Information Service, U. S. Department of Commerce.

APPENDIX E

ADVANCEMENTS IN MEDICINE FROM AEROSPACE RESEARCH

*(Paper presented at the Conference on Space for Mankind's
Benefit, Huntsville, Alabama, November 16-19, 1971)*

ADVANCEMENTS IN MEDICINE FROM AEROSPACE RESEARCH

by

F. Thomas Wooten

Presented at the

Conference on

SPACE FOR MANKIND'S BENEFIT

Huntsville, Alabama

November 16 - 19, 1971

This work supported under Contract #NASW-2273

by the

National Aeronautics and Space Administration

ADVANCEMENTS IN MEDICINE FROM AEROSPACE RESEARCH

F. Thomas Wooten
Research Triangle Institute
Research Triangle Park, North Carolina

INTRODUCTION

The world has recently viewed the dramatic successes of a space effort which chose a difficult goal and then carefully developed the technology necessary to reach that goal. This paper discusses a program which is designed to find second applications in the field of medicine for the technology developed to achieve the nation's space goals. The program is the outgrowth of the congressional charter included in the Space Act of 1958 which directed NASA to find second applications for the technology which resulted from NASA's R & D programs.

For several years NASA has sponsored a program which has at its core multidisciplinary teams of scientists and engineers called Application Teams. Such a team is located at each of three not-for-profit research institutes (Research Triangle Institute of North Carolina, Southwest Research Institute of Texas, and Midwest Research Institute of Missouri) and one medical school (Stanford University). The teams seek to provide an interface between two diverse fields: aerospace and medicine.

The medical profession has awakened in the past decade to the need for advanced technology in medical research and health care. This awakening alone is not enough. Some effective avenues for the flow of information, ideas, and technology between the physical and medical sciences have been established, but more are needed. This program provides one such avenue.

METHODOLOGY

Technology utilization is the term applied to the task of finding second applications for technology. Many of the methods for implementing the concept of technology utilization are largely passive in nature; passive in this case means the information is provided to those who seek it and thus, the physician must understand the information system in order to use it. One of the unique features of the Application Team program is that the method is active. Active, in this sense, means that the problems and solutions are actively sought.

This search for problems is carried out by the members of the multi-disciplinary team. Team members visit major medical centers (the National Institutes of Health and medical schools) where suitable medical problems are identified with the aid of a consultant. The consultant, a medical center staff member, helps to insure that the problems selected meet certain minimum requirements. In general our team accepts only those problems which (1) have no solutions available on the commercial market, (2) are discrete and can be defined in specific terms, (3) impede the progress of priority efforts of the physician, and (4) appear amenable to solution by aerospace related technology. We impose these requirements because this program is designed for problem solving, not just information searching.

If a problem meets these requirements, it is defined by the physician and team member during one or more meetings. Problem definition can probably best be explained by an example: Arthritis is a crippling disease which can result in the destruction of the ball and socket joint of the hip. One method of treating this disease is to replace the human hip ball and socket joint with an artificial material. An orthopedic surgeon asked the team to find an improved material. The team quickly determined that the basic problem was that existing materials have inadequate friction and wear characteristics. The team looked for improved low friction bearing materials which were biocompatible and not just for prosthetic hip joint materials. Thus, the search could be broadened to areas unrelated to medicine.

After a problem is defined, a solution is sought using several approaches. First, a computer search of the NASA document bank is performed which covers approximately 700,000 documents. The bibliography and related documents are analyzed by the physician and the team member to determine whether an adequate solution is available.

A second approach used in finding solutions is to request suggestions from NASA personnel by circulating concise written problem statements to the NASA field centers. These documents are circulated by the Technology Utilization Officers (TUO) who are located at each center and who have a detailed knowledge of the research activities at their centers. The TUO provides a vital link between the teams and key NASA personnel.

A third approach is to contact field center personnel or NASA contractor personnel directly when the teams are aware that these personnel have knowledge about particular problems. These contacts, coordinated with each TUO, allow the teams to rapidly obtain advanced technological information.

After an idea or individual has been identified by these searching procedures, both direct and indirect contacts between physicians and NASA personnel are arranged. In the former case, physicians have visited NASA centers for discussions; in the latter case, the team

members have provided the contact by visits and correspondence. Always the idea is to provide the physician with fresh insight into his problem from a discipline he does not normally encounter.

The team then acts as a catalyst to provide implementation of the ideas. Although the primary responsibility for implementation of the technology lies with the physician, the team assists in engineering consultation and in recommendations for ways of applying the technology. In addition, in a few instances NASA has initiated feasibility studies directly when it is clear that no other avenues are open to the physician and when the necessary expertise is available only within NASA. At all times, the team feels that success comes only when utilization has occurred.

PROGRAM ANALYSIS

Because the transfer of technology in this active mode is a unique venture, significant efforts are made to analyze the transfer process so that improvements in transfer methodology can occur. The analysis phase of the program has disclosed several important facts about the problem of finding second applications for space technology. First, although the searching of document files is one key aspect of the program, it is not the most important aspect. Most information systems are designed to retrieve information directly related to a subject. Information that is indirectly related to a subject cannot be easily retrieved unless the searcher has some initial clues. As an example, a search for methods of rapidly heating blood would probably not include semiconductor fabrication as a search term unless the searchers were aware that microwave heating is a vital aspect of semiconductor fabrication processes. Thus, search results are limited by the experience of the searcher.

The second important lesson learned from this program is that personal interaction is vital when two diverse disciplines are attempting to interact. In fact, disciplines do not really interact, but people do. The "interaction" between two diverse disciplines really results when two people sit down to talk. If we simply give a physician an engineering document, the results are usually quite low. Consider two examples: (1) The physician cannot begin to realize the significance of modern communications technology to his method of dispensing health care, and (2) the engineer cannot recognize the significance of his cryogenic technology to leukemia therapy until face-to-face and repeated interaction occurs. Personal interaction between all elements of the team program (physician, team member, and aerospace engineer) has been found to be of major importance for success.

EXAMPLES OF RESULTS

In order to illustrate both the methodology and the results of the Application Team, examples of particular problems will now be discussed.

In Figure 1, a prototype of a prosthetic urethral valve is shown. This valve is designed to meet the needs of patients with urinary incontinence or the inability to voluntarily control urination. In addition to the obvious social and hygienic implications of incontinence, this inability to control urination can result in tissue deterioration, infection, kidney damage, and eventually death. Previous attempts to solve this problem using electrical stimulation have not been satisfactory.

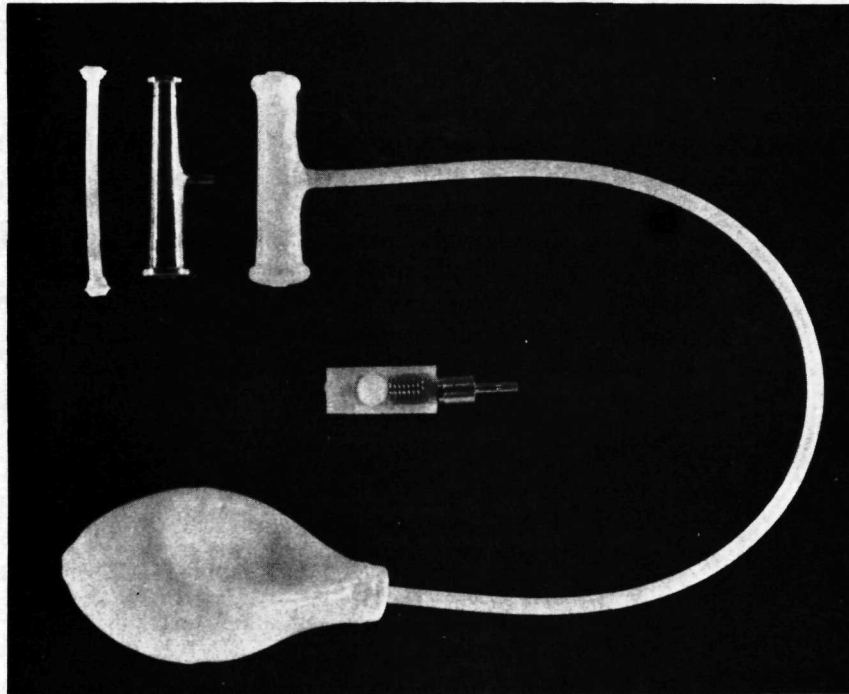

Figure 1. Prototype Prosthetic Urinary Valve

One problem in attempting to use a valve in the urinary system is that urine causes an incrustation that fouls most valves. This problem was posed to NASA engineers at Lewis Research Center who proposed the use of a flexible membrane valve. A team engineer proposed a check valve that together with the bulb shown in Figure 1, forms a bistable valve which controls the urine flow. This device is now undergoing testing in experimental animals, and if it is perfected, an estimated 15,000 patients per year could benefit from this device.

The next example concerns the need for careful monitoring of leukemia patients who, not uncommonly, die because of shock--as opposed to some cause more directly related to the proliferation of white blood cell forming tissue. In order to prevent these deaths, the National Cancer Institute asked the team to find a means of monitoring blood pressure without significantly disturbing the patient. Conventional blood pressure measurements require an occlusive cuff which is clearly unsuitable for frequent, round-the-clock monitoring.

A direct contact with NASA's Ames Research Center revealed that an ear oximeter had been developed for measuring oxygen content of the blood of astronauts in ground testing. This device, shown in Figure 2, was also sensitive to relative changes in blood pressure. Although previous ear oximeters required that blood flow in the ear be occluded in order to measure blood pressure, this new NASA development removed this requirement and the resulting discomfort. At the present time, the NASA ear oximeter is undergoing clinical trials at the National Cancer Institute. Successful conclusion of these trials could result in savings of hundreds of lives annually.



Figure 2. Ear Oximeter

A third example of an application of aerospace technology resulted when the Environmental Protection Agency (EPA) wanted to study the effects of low levels of carbon monoxide on automobile drivers. A search revealed that a NASA scientist at Langley Research Center had developed an instrument, shown in Figure 3, which measured the coordination and reaction time of astronauts exposed to contaminants in spacecraft. This instrument was loaned to EPA and is now being used for the planned study. Although the new application of the equipment is not significantly different from the basic NASA use, it is interesting to note that EPA had planned to develop such an instrument on contract so that a significant savings in tax dollars resulted.

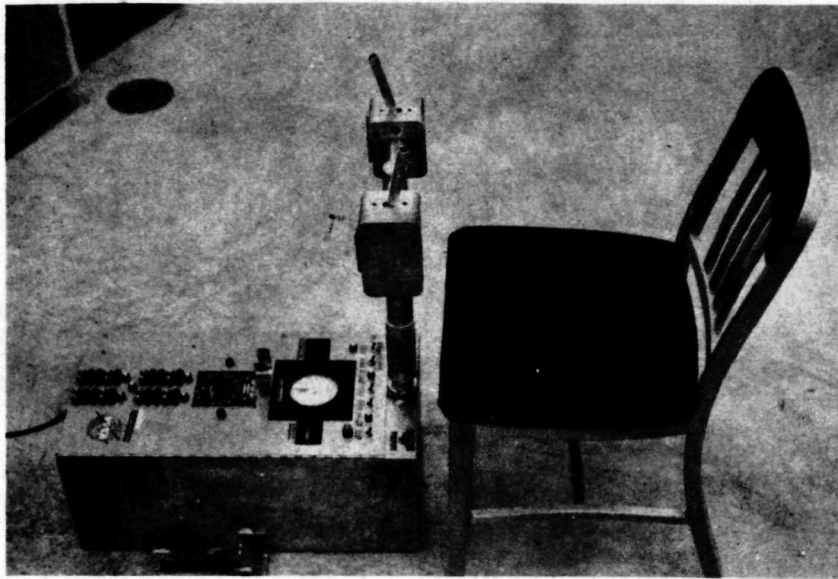

Figure 3. Complex Coordinator

A fourth example is shown in Figure 4. This is a radiation dosimeter probe developed under NASA sponsorship for nonmedical purposes and is now being used to measure the radiation level absorbed around cancerous areas in order to determine the position of administered radioisotopes. This allows more precise definition of cancerous areas and prevents damage to surrounding healthy tissue.

The final example of a transfer concerns the need for an improved electromyographic muscle trainer. When muscles of the hand become damaged or atrophied, an electromyographic muscle trainer is employed to determine whether or not a specific muscle is being used. The trainer consists of two electrodes, an amplifier, and a speaker which allows the patient to hear when a specific muscle is being used, but the bulky electrodes previously employed were too large for proper results.



Figure 4. Radiation Dosimeter

Figure 5 shows the use of small electrodes devised from NASA-developed spray-on electrode formulations. With these electrodes no further attachment mechanism is needed for the wires, and the electrodes provide extremely satisfactory results. The improved access to the muscle being exercised permits improved rehabilitation procedures for a significant number of patients. The technique is already in use in several rehabilitation centers.



Figure 5. Electromyographic Electrodes

CONCLUSIONS

This paper has described a new and exciting approach to the process of finding new applications for space technology. NASA has taken the lead in implementing the concept of technology utilization, and the Technology Utilization Program is the first vital step in the goal of a technological society to insure maximum benefit from the costs of technology. Experience has shown that the active approach to technology transfer is unique and is well received in the medical profession when appropriate problems are tackled. The problem solving approach is a useful one at the precise time when medicine is recognizing the need for new technology.

It is significant that the decade which heralded the space age is also the decade that signaled the awakening of medicine to the need for technology. Whether the coincidence is directly related, indirectly related, or unrelated can be argued by philosophers. But this simultaneous occurrence cannot be ignored, and this program is one step in the many that are needed to fulfill medicine's needs. Thus, the Application Team program clearly fits the purpose of this conference which is to discuss "Space for Mankind's Benefit."