

CR-128518



(NASA-CR-128518) FUEL CELL TECHNOLOGY
PROGRAM Final Report (Pratt and Whitney
Aircraft) 27 Apr. 1972 82 p
CSCL 10A

72-33528

Unclas
G3/C3 16349

Pratt & Whitney Aircraft, Inc. DIVISION OF UNITED AIRCRAFT CORPORATION



Fuel Cell Technology Program
Final Report
PWA-4364

NASA Contract No. NAS9-11034

Exhibit C, Paragraph 2.3.4

April 27, 1972

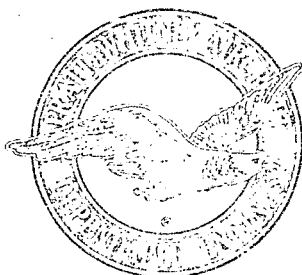

Prepared For

National Aeronautics and Space Administration
Manned Spacecraft Center
Power Generation Branch
Houston, Texas - 77058

Approved By:

R. Falcinelli
R. Falcinelli

Project Manager

Pratt & Whitney Aircraft



EAST HARTFORD, CONNECTICUT

Details of illustrations in
this document may be better
studied on microfiche

N O T I C E

THIS DOCUMENT HAS BEEN REPRODUCED FROM THE BEST COPY FURNISHED US BY THE SPONSORING AGENCY. ALTHOUGH IT IS RECOGNIZED THAT CERTAIN PORTIONS ARE ILLEGIBLE, IT IS BEING RELEASED IN THE INTEREST OF MAKING AVAILABLE AS MUCH INFORMATION AS POSSIBLE.

FOREWORD

This Fuel Cell Technology Program Final Report was prepared by Pratt & Whitney Aircraft Division of United Aircraft Corporation, South Windsor Engineering Facility, South Windsor, Connecticut, in accordance with the requirements of Paragraph 2.3.4 of Exhibit C to NASA Contract NAS9-11034.

TABLE OF CONTENTS

	<u>Page</u>
1.0 SUMMARY	1
2.0 CONCLUSIONS AND RECOMMENDATIONS	3
3.0 ENGINEERING MODEL (EM-1) CONCEPTUAL DESIGN	4
3.1 System Configuration	4
3.2 System Arrangement	11
3.3 EM-1 Weight Analysis	11
3.4 In-flight Shutdown and Storage	11
3.5 Heat Pipe Heat Removal	11
3.6 Powerplant Coolants	14
3.7 Fuel Cell Powerplant Flight Instrumentation and Control Information	14
4.0 DEMONSTRATOR MODEL -1 (DM-1) SYSTEM DESIGN	20
5.0 DEMONSTRATOR MODEL-1 (DM-1) FABRICATION, ASSEMBLY AND TEST	25
5.1 DM-1 Fabrication and Assembly	25
5.2 DM-1 Testing	25
6.0 TECHNOLOGY ADVANCEMENT - HIGH POWER DENSITY CELL	34
6.1 Task Objective and Approach	34
6.2 High Power Density Cell Description	34
6.3 Evaluation of the High Power Density Cell	37
6.3.1 Evaluation of Propellant Reactants (SC-21)	37
6.3.2 Operating Life Test (SC-31)	38
6.3.3 Multicell Operating Life Test (MC-11A)	39
6.3.4 Multicell Operating Life Test (MC-31)	40
6.4 Advanced Frame, Coolant Plate, and Matrix Evaluation	43
6.4.1 Plastic Frames	43
6.4.2 Electroformed Nickel Foil Coolant Plates	43

TABLE OF CONTENTS

	<u>Page</u>
6.4.3 Improved Asbestos Matrix	45
7.0 TECHNOLOGY ADVANCEMENT - GAS DRIVEN CIRCULATORS AND STATIC WATER SEPARATOR	48
7.1 Task Objective and Approach	48
7.2 Oxygen-driven Coolant Pump	48
7.3 Hydrogen Jet Pump	50
7.3.1 Hydrogen Jet Pump Design Support Testing	50
7.3.2 DM-1 Hydrogen Jet Pump	53
7.4 Static Water Separator	53
7.4.1 Static Water Separator Design Support Testing	58
7.4.2 Static Water Separator Module Test	60
7.5 Open Cycle Heat and Water Removal	60
7.5.1 Intercell Evaporator	64
7.5.2 Humidity Sensor	64
7.5.3 Four Cell Breadboard Unit Test	65
8.0 REACTANT PURIFIERS	67
9.0 CONTRACTOR LIAISON	69
10.0 COMPLEMENTARY ENGINEERING	72
10.1 Reliability	72
10.2 Safety	73
10.3 Quality Assurance	75

LIST OF FIGURES

<u>Figure No.</u>	<u>Title</u>	<u>Page</u>
1	Comparison of Baseline Requirements	4
2	Engineering Model Flow Schematic (Gas Driven Pumps)	6
3	Engineering Model Flow Schematic (Electric Driven Pumps)	7
4	Open Cycle Heat and Water Removal	9
5	EM-1 Powerplant Estimated Electrolyte Concentration with and without Oxygen Ejector (5 kw average Power Level)	10
6	EM-1 Flow Schematic	12
7	EM-1 Powerplant Conceptual Arrangement	13
8	Vapor Pressure of Fluorocarbon Coolants	15
9	Measurements List	16
10	Control Signal List	17
11	NR Shuttle Fuel Cell Powerplant Electrical Schematic	18
12	MDAC Shuttle Fuel Cell Powerplant Electrical Schematic	19
13	DM-1 Design Parameters	21
14	DM-1 Powerplant Flow Schematic Electric Driven Pump Configuration	22
15	DM-1 Powerplant Flow Schematic Gas Driven Pump Configuration (Alternate)	23

LIST OF FIGURES

<u>Figure No.</u>	<u>Title</u>	<u>Page</u>
16	Cut-away of High Power Density Cell	26
17	Complete DM-1 Fuel Cell Stack	27
18	DM-1 Power System	28
19	DM-1 Test Plan	30
20	DM-1 Power Profile	31
21	Performance Comparison of High Power Density and PC8B Cells	36
22	Asbestos Matrix Physical Properties Com- parison	46
23	Asbestos Matrix Material (10 Mil) Cross Section at 200X	47
24	Oxygen-Driven Coolant Pump Demonstrated Performance compared with System Requirements	49
25	EM-1 Oxygen Driven Coolant Pump	51
26	Space Shuttle Endurance Pump	52
27	Dual Jet Pump Parallel Configuration	54
28	Dual Jet Pump Series Configuration	55
29	DM-1 Hydrogen Jet Pump	56
30	DM-1 H ₂ Jet Pump Performance	57
31	Static Water Separator	59
32	Static Water Separator Configuration	61

LIST OF FIGURES

<u>Figure No.</u>	<u>Title</u>	<u>Page</u>
33	Multi-module Static Water Separator	62
34	Intercell Evaporative Cooling Assembly	63
35	Wet Bulb Humidity Sensor	64
36	Four Cell Breadboard Unit Cell Stack	66

1.0 SUMMARY

A fuel cell technology program was established under NASA contract NAS9-11034 to advance the state-of-the art of hydrogen-oxygen fuel cells using the P&WA low temperature, potassium hydroxide electrolyte technology as the base. The tasks of this program consisted of 1) fuel cell system studies to define a Space Shuttle powerplant conceptual design (designated Engineering Model-1, EM-1), 2) a Demonstrator Powerplant (DM-1) test, 3) component and subsystem technology, 4) liaison with the Space Shuttle Prime Contractors and 5) Complementary Engineering task which included Reliability, Quality Assurance, and System Safety.

Fuel cell system studies to define the EM-1 conceptual design included determination of voltage regulation, specific reactant consumption, weight, voltage level and performance characteristics. These studies provided the basis for coordination activities with the Space Shuttle vehicle prime contractors. Interface information, on-board checkout and in-flight monitoring requirements, and development cost data were also provided as part of this activity. Even though the two Phase B vehicle primes had different voltage requirements (115 volts in one case and 28 volts in the other), it was concluded that either option could be provided in the fuel cell power system by the electrical hook-up of the cells in the stack.

Component and subsystem technology activities included four areas of interest. These were: 1) the high power density cell, 2) reactant purifiers, 3) gas driven circulators, and 4) open cycle heat and water removal.

The objectives of the high power density cell effort were to extend the cell operating life and energy delivery capability of the FC8B baseline technology. A cell exceeded the NASA goal of 5,000 hours, having operated more than 10,000 hours with performance at that time still above initial performance.

The objective of the reactant purifier program was to provide a reactor for powerplant operation on propellant grade reactant gases containing carbon dioxide and hydrocarbons. Platinum, Palladium and Rhodium catalysts were tested in a reactor to catalytically convert the trace hydrocarbons to carbon dioxide for removal by a scrubber. The Rhodium catalyst was found to be most effective.

The objective of the gas driven circulator activity was to provide a hydrogen pump and a coolant pump which used the stored pressure energy of the supply reactants. Their use would eliminate electric motors and parasitic electric loads from the fuel cell system. The use of a gas driven hydrogen circulator necessitated the development of a static water separator to remove product water from the recirculating hydrogen stream. An oxygen driven coolant pump was built and endurance tested. A two stage hydrogen jet pump and a static water separator were built and bench tested.

The objective of the open cycle heat and water removal subsystem effort was to provide an alternate mode of removing fuel cell powerplant waste heat and product water when the Space Shuttle vehicle radiator is inoperative. An intercell evaporator which vented steam overboard and a humidity sensing hydrogen/water vent system were designed to accomplish this objective. A four cell operating breadboard system test demonstrated the feasibility of this approach.

The objective of the DM-1 demonstrator powerplant task was to demonstrate the fuel cell technology at the system level for a 2000 hour period. The powerplant demonstrated the ability to operate at low and high reactant supply pressures, bootstrap (self-start) capability, spike transient capability to 10.5 kw, open cycle water removal for periods longer than one hour and unattended automatic operation. However, the 2000-hour test objective was not met. At 610 hours of operation, the test was interrupted because of a gear failure in the Block II Apollo hydrogen pump and at 750 hours the test was terminated because of a cell failure allowing reactant gas crossover.

The pump problem was determined to be the result of operation at an undamped natural frequency which caused accelerated gear wear. During failure investigation of the power section, testing was conducted which duplicated the physical condition of the DM-1 cells by application of a 45 psi hydrogen over-pressure. It was concluded from this that the coupled regulator (breadboarded with two Apollo regulators modified to provide remote sensing) produced a temporary pressure imbalance which distorted the electrodes and caused a performance loss and uneven heat transfer and current density. This subsequently caused a localized matrix dryout and reactant gas crossover.

Although it is theorized that the DM-1 failure was caused by the regulator and that a more reliable regulator would have a much lower probability of causing such an event, it was recommended to NASA that follow-on activity should be directed toward making the cell less susceptible to reactant crosspressures and manufacturing variations.

2.0 CONCLUSIONS AND RECOMMENDATIONS

Cell and component testing confirms that low temperature, potassium hydroxide electrolyte technology is compatible with the requirements of the Shuttle Phase B contractors as defined during the contract liaison activities.

Testing of the DM-1 powerplant demonstrated all of the important requirements of the Shuttle except operating life. Testing also identified DM-1 powerplant life limiting mechanisms; hydrogen pump gear wear and pressurization of the cell stack over its design limits.

It is recommended that near term effort be concentrated on demonstrating (1) a potentially long life hydrogen pump-separator and (2) cells with improved overpressure capability.

It is further recommended that successful testing of these two technology elements be followed by powerplant endurance testing.

3.0 ENGINEERING MODEL (EM-1) CONCEPTUAL DESIGN

3.1 System Configuration

Conceptual design of a fuel cell system designated Engineering Model - 1 (EM-1) was a major task of this program. The objective of this task was to define a fuel cell system configuration which would meet the requirements of the Space Shuttle Orbiter vehicle. The EM-1 operating characteristics were initially based on NASA guidelines provided at program inception. As liaison activities with the Phase B prime contractors, North American Rockwell (NR) and McDonnell-Douglas Aircraft Corporation (MDAC) progressed, the specific powerplant requirements of each one were defined. Figure 1 shows a comparison of the NASA and prime contractor baseline requirements at the end of the contract period.

<u>Characteristics</u>	<u>NASA Guidelines</u>	<u>NR</u>	<u>MDAC</u>
. Sustained Power - KW	5	7	7
. Peak Power within Voltage Regulation - KW	10	10	14
. Minimum Power within Voltage Regulation - KW	0	1.5	0
. Voltage Regulation Band	26.6-29.4V ± 5%	27.6-31.0V ± 6%	108-126V ± 7.7%
. Specific Reactant Consumption - Lb/KWH	.8	-	-
. Reactant Supply			
- Min Pressure-PSIA	20 & 200	200	200
- Grade	Propulsion	Fuel Cell	Propulsion
. Alternate Heat & H ₂ O Removal	Yes	No	Yes
. Operating Life - Hr	5000	5000	5000

Figure 1 - Comparison of Baseline Requirements

The initial EM-1 arrangement is shown in Figure 2. This arrangement incorporated all of the features of the technology improvement program. Namely, high power density cells, reactant purifiers, gas driven recirculators, static water separator and open cycle heat and water removal subsystem. Each of these items are described in greater detail in the technology section of this report.

Space Shuttle vehicle fuel cell installations which used low pressure reactants from the propellant supply tanks were also considered. These reactants were supplied to the fuel cell at about 20 psia. System studies showed that this pressure level was insufficient to provide the energy needed to drive the gas driven pumps. An electrically driven pump was considered in place of the oxygen driven coolant pump and an electrically driven hydrogen pump/separator was considered in place of the hydrogen jet pump and static water separator for this application. Figure 3 shows the EM-1 arrangement incorporating electrically driven pumps. This system has the advantage of being capable of operating at any reactant supply pressure level.

The open cycle heat and water removal subsystem provides an alternate means of waste heat and product water removal in the event that normal spacecraft heat removal systems are inoperative. Normal product water removal for electrolyte concentration control is accomplished by passing the hydrogen/water vapor mixture from the stack exit through a condenser which causes the water vapor to condense into droplets. These droplets are then removed by either the hydrogen pump/separator or the static water separator, depending on whether the system has electrically driven or gas driven pumps. If the condenser is not supplied with coolant sufficiently low in temperature, the water vapor in the recirculating stream will not condense and can not be removed by the separators. The open cycle water removal subsystem can provide this function under this circumstance. In this case product water removal is accomplished by direct overboard venting of saturated hydrogen from the hydrogen recirculation loop. Venting is controlled by a humidity probe which senses the wet bulb temperature of the recirculating hydrogen stream at the cell stack exit. This temperature is compared to the dry bulb temperature of the gas stream. When a difference of the two readings (preset, based on the desired gas stream humidity to maintain electrolyte concentration control) is exceeded, the solenoid operated hydrogen/water overboard vent valve opens. When the humidity of the stream returns to the normal range, the valve is automatically closed.

PAGE NO. 6

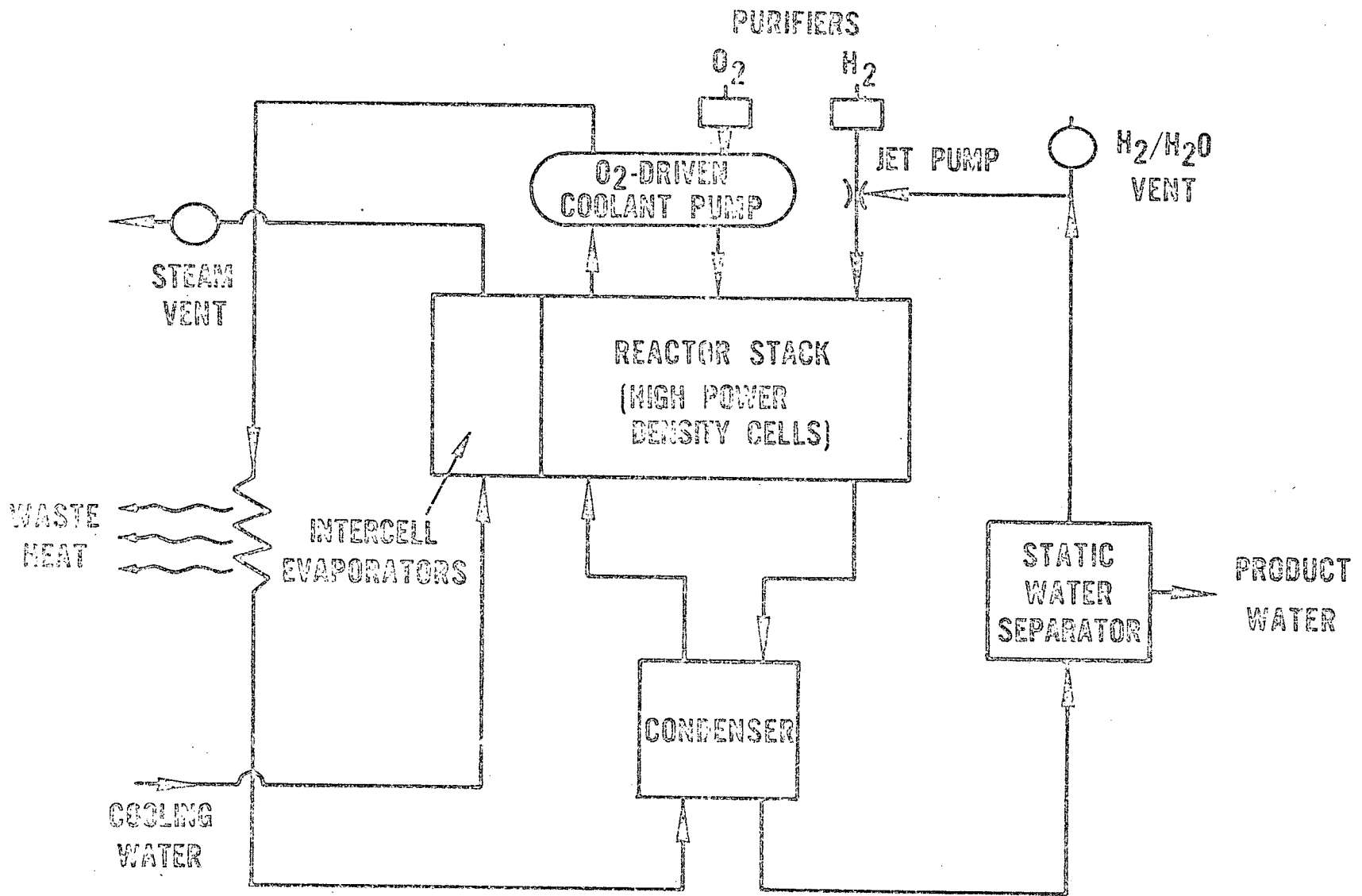

Figure 2 - Engineering Model Flow Schematic (Gas Driven Pumps)

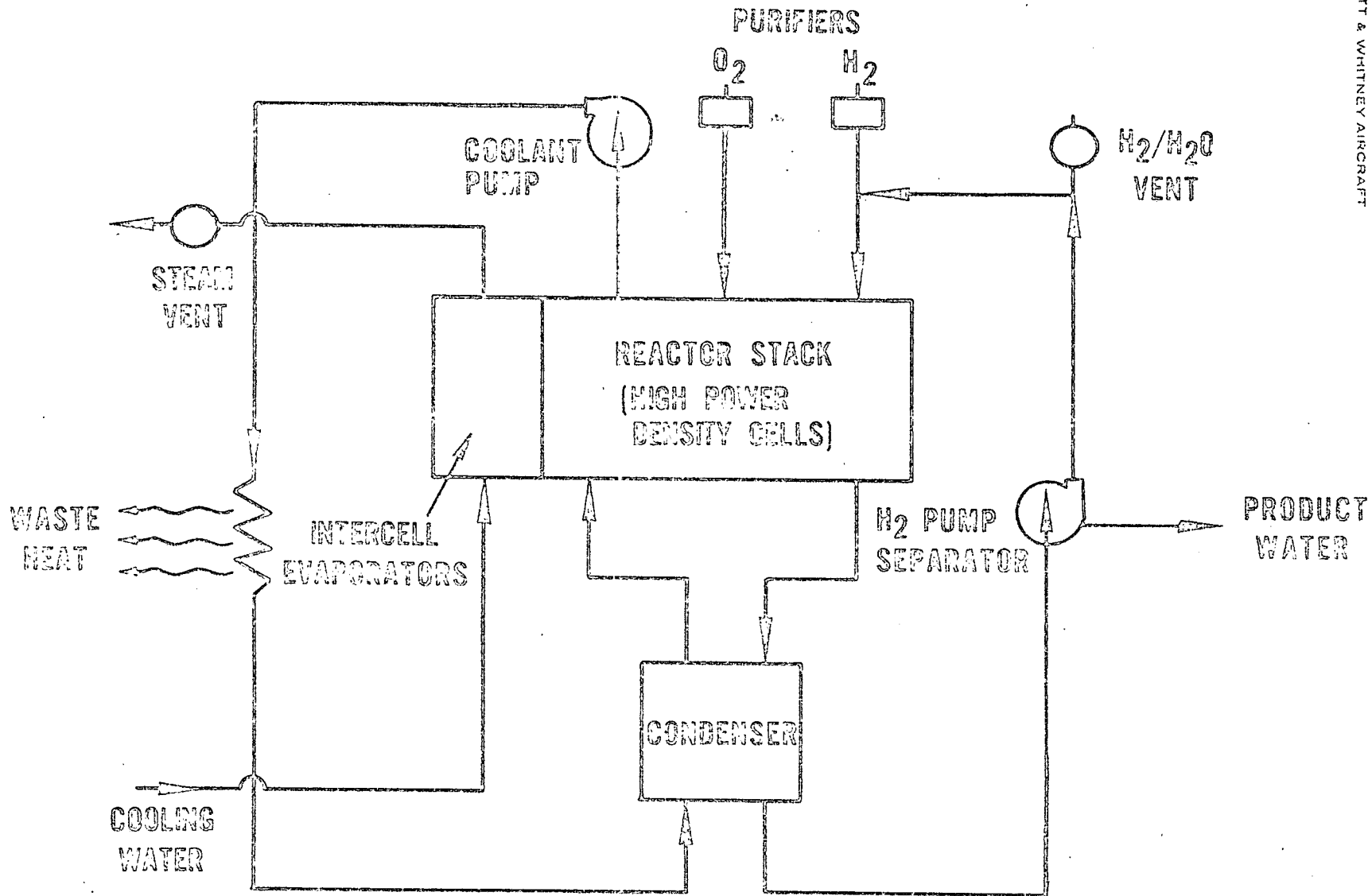

Figure 3 - Engineering Model Flow Schematic (Electric Driven Pump)

Normal waste heat removal is accomplished by circulating coolant through the cell stack and removing the waste heat to a spacecraft radiator or heat sink. In the event that the spacecraft system becomes inoperative, a temperature rise will occur in the cell stack. The open cycle heat removal subsystem can maintain stack temperature control in this event. When a preset stack temperature limit is reached, a solenoid operated valve will allow cooling water to enter intercell evaporators installed in the cell stack. The water turns to steam in the evaporators and the steam is then vented overboard. The temperature is maintained through pressure control by the steam vent pressure regulator.

Prime contractor trade-off studies of preferred vehicle configurations concluded that this alternate mode of heat and water removal was not necessary. However, maintaining the product water removal portion of the subsystem was a desirable option since considerable waste heat is also removed in the process of overboard venting of the hydrogen/water stream. Figure 4 shows the results of system studies comparing the spacecraft radiator heat rejection load vs. fuel cell power for normal operation (closed cycle), open cycle water removal, and open cycle heat and water removal. It can be seen that for a 5 kw level, the radiator heat rejection is reduced one-half by open cycle water removal alone.

Studies showed that a choice between gas driven or electric driven pumps was not significant from a system operation viewpoint. Electric pumps showed a slight weight advantage and have the flexibility of operating with either high or low reactant supply pressures. Gas driven pumps offer lower parasite power but require more development at this point than the electric driven pumps. It was concluded from these studies to consider the electric driven pumps as the preferred choice.

A study was made to determine the effect on electrolyte concentration of pre-humidifying the oxygen supplied to the cells. Prehumidification can be achieved by using an oxygen ejector to recirculate wet exit oxygen gas into the inlet makeup oxygen upstream of the cell. The reduced electrolyte concentration minimizes any tendency to form potassium carbonate in the cell oxygen inlet. The study compared the localized electrolyte concentration along the cell oxygen flow path with and without an oxygen ejector for the EM-1. The oxygen flow was in the same direction as the coolant (co-flow) and was at the optimum recycle flow ratio (exit flow/makeup oxygen flow). Figure 5 shows the results of this study.

PAGE NO. 9

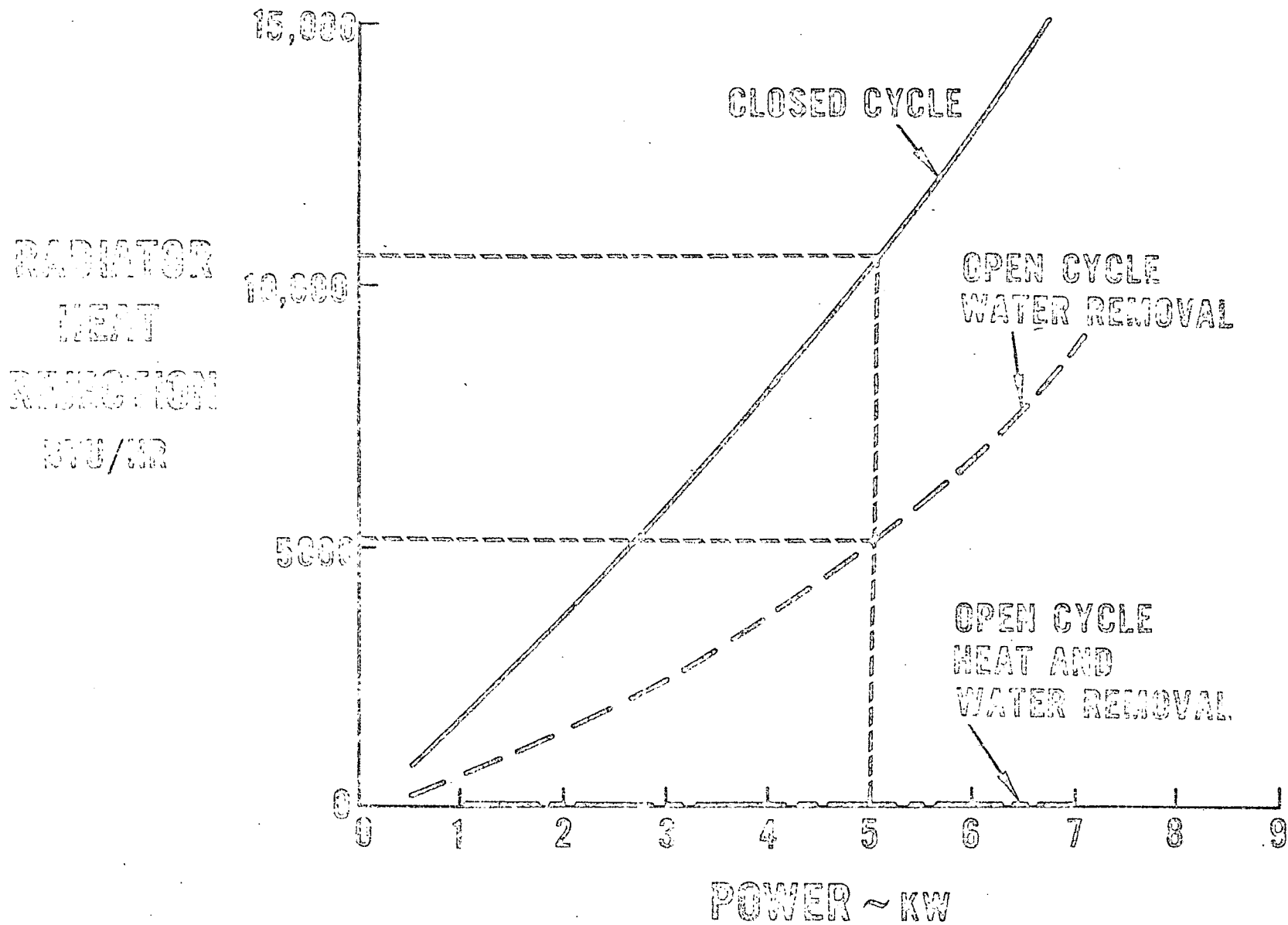

Figure 4 - Open Cycle Heat and Water Removal

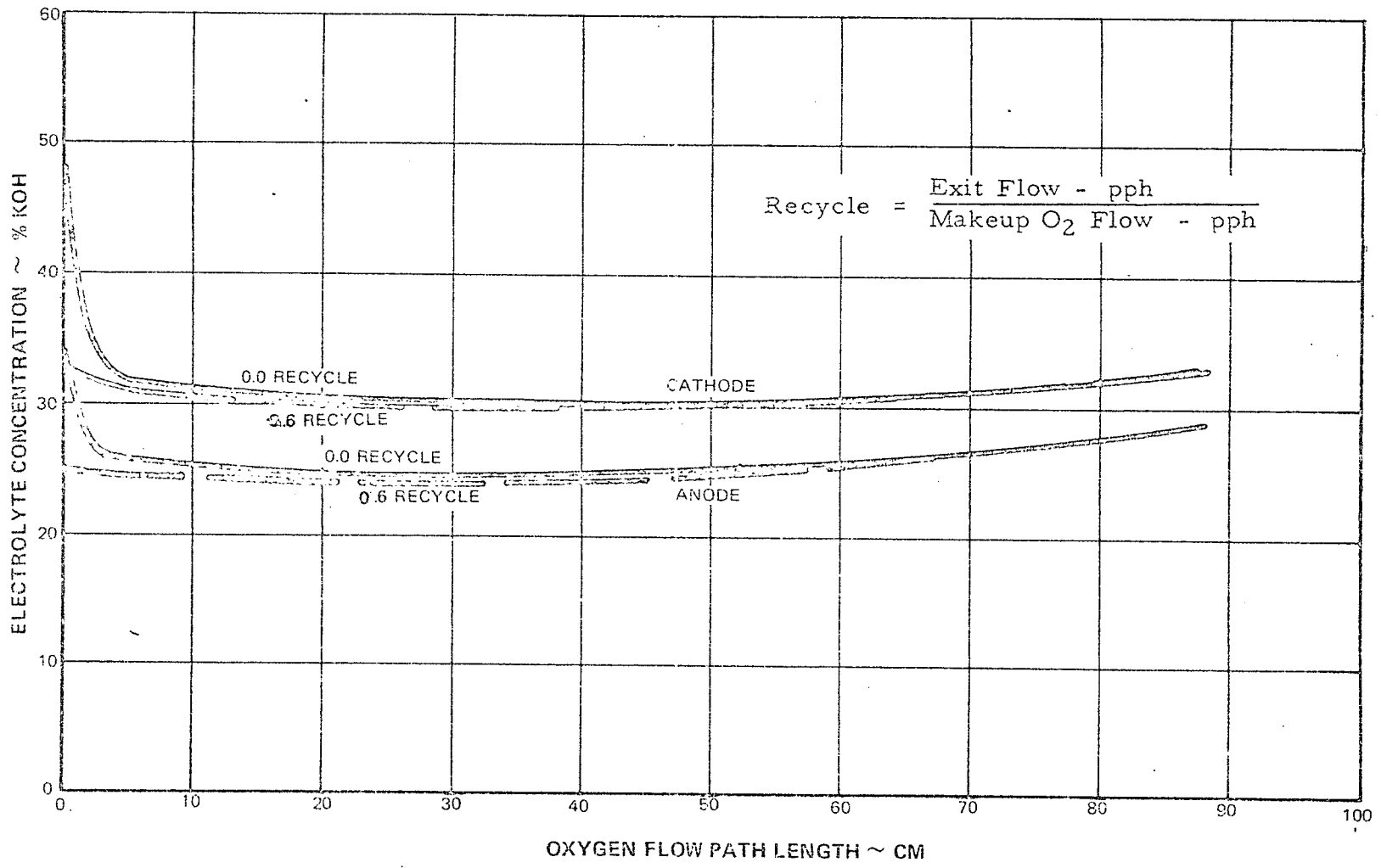

Figure 5 - EM-1 Powerplant Estimated Electrolyte Concentration with and without Oxygen Ejector (5 kw Average Power Level)

Figure 6 shows a flow schematic of the EM-1 Configuration incorporating the preferred features as indicated by the various system studies. This system will form the basis for further follow-on design activities.

3.2 System Arrangement

A conceptual design layout of the EM-1 powerplant was prepared and a mockup showing the component arrangement was constructed. Figure 7 is a sketch of the packaging arrangement proposed for a Space Shuttle vehicle installation. Accessibility of the components for maintenance and repair based on reliability analyses was considered in the location of the components. Arrangement of the control components at one end of the cell stack as shown in Figure 7 was selected for ease of assembly and separation of the stack and accessory section. This arrangement facilitates field maintenance and repair.

3.3 EM-1 Weight Analysis

Trade-off studies were conducted to determine the influence of various operating parameters on powerplant weight. The results of the study showed that voltage level (28 vdc vs. 110 vdc) has little impact on powerplant weight, but voltage regulation requirements have a great effect on weight. For example, a relaxation of the voltage regulation from ± 5 to ± 10 percent reduced the baseline specific weight by approximately 30 percent. Results of these studies were provided to the vehicle prime contractors for their studies.

3.4 In-Flight Shutdown and Storage

An in-flight shutdown and storage procedure was defined that would maintain the capability for an instant powerplant restart. Consideration was given to procedures which maintained a pressure balance between the two reactant systems at or above the partial pressure of the water in the electrolyte to prevent water dryout. Results of the study indicated that this can be readily accomplished.

3.5 Heat Pipe Heat Removal

A design study was made of a heat pipe heat removal system in the EM-1 power system. State-of-the-art information of heat pipes was supplied by Dynatherm Corporation of Baltimore. Results of this study are presented below:

- Use of heat pipes offered no potential weight or volume reduction for the Space Shuttle because secondary heat removal system must be employed to deliver the fuel cell waste heat to the vehicle radiator.

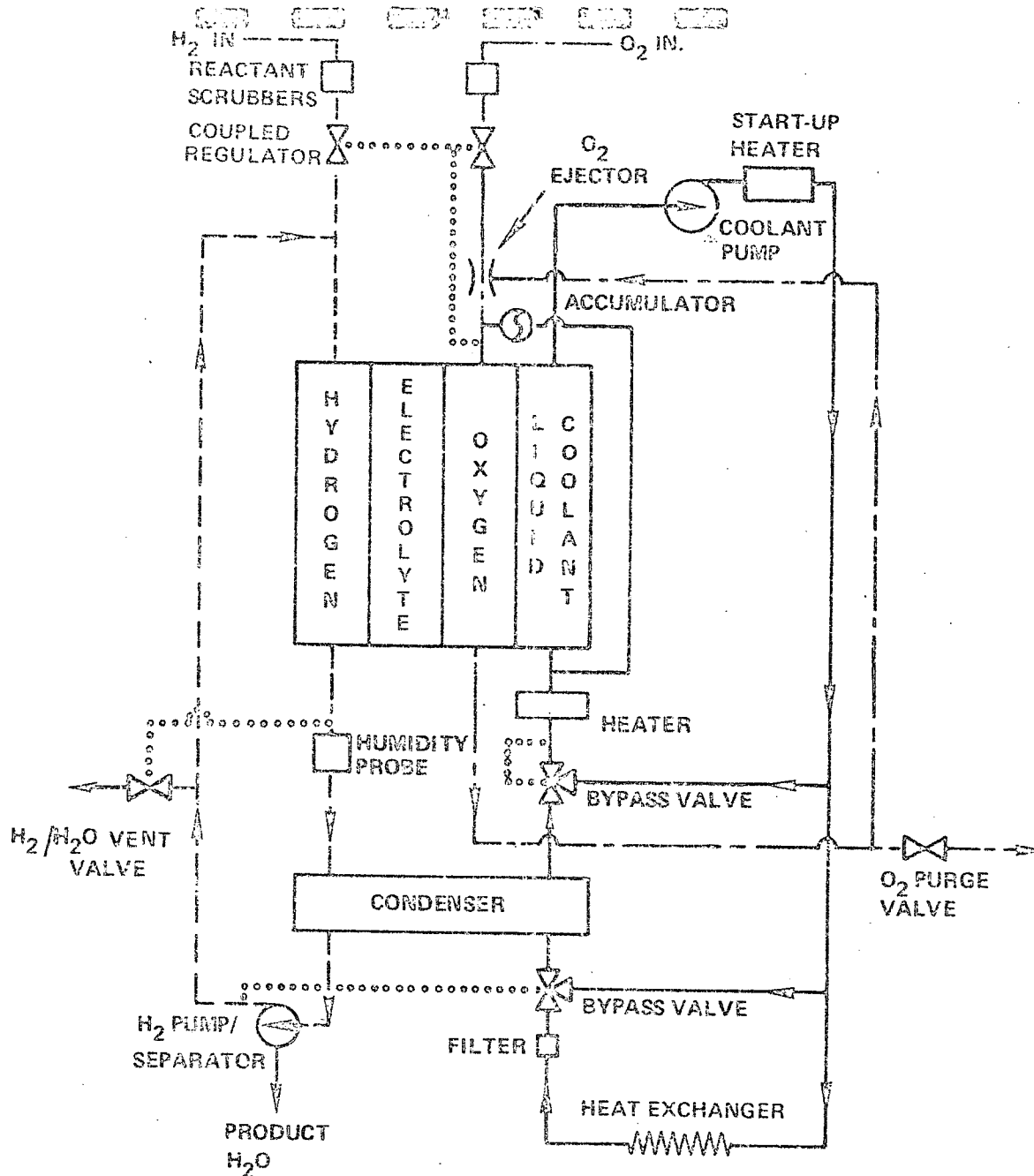

Figure 6- EM-1 Flow Schematic

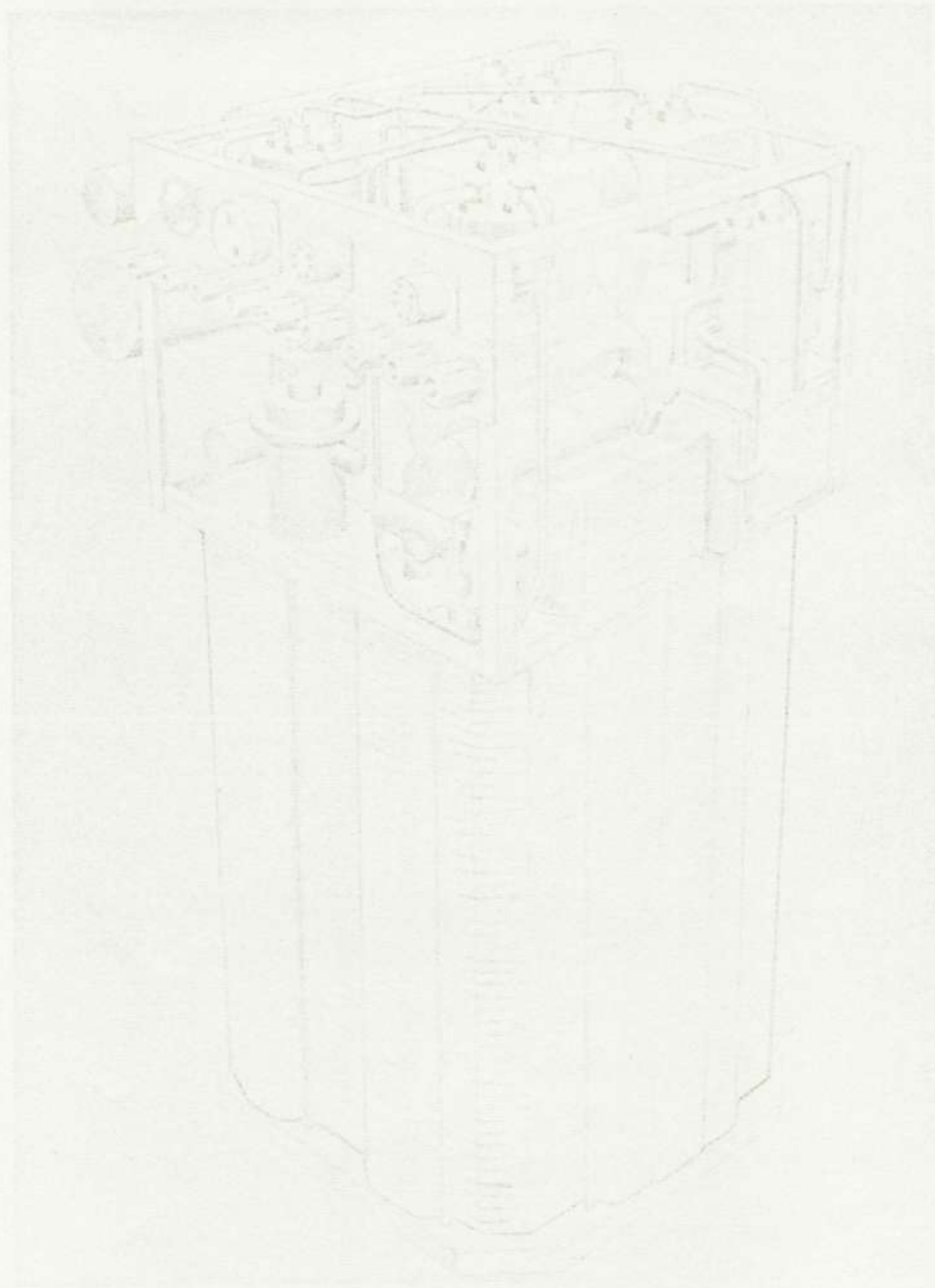

Figure 7 - EM-1 Powerplant Conceptual Arrangement

- . A major mechanical difficulty was imposed on the fuel cell power stack because the heat pipe system must exhibit a high heat flux capability (i. e. consistent with high power density) while maintaining the necessary electrical insulation with the secondary or vehicle heat rejection loop. As each cell heat pipe would have to be electrically isolated from the vehicle, a significant reliability penalty resulted.
- . Heat pipes in the Space Shuttle installation did not eliminate the need for thermal control valves.
- . As the heat pipe was adversely affected in one plane by gravity, preferential orientation of the EM-1 was required.

3.6 Powerplant Coolants

Previous studies have shown that fluorocarbon coolant fluids are compatible with the magnesium separator plates in the fuel cell stacks. The specific fluorocarbon coolant fluid to be used depended on its vapor pressure characteristics and cost. Of the five available fluids, three (FC-40, 43, and 48) were applicable to all prospective operating conditions and two (FC-75 and 77) were limited to the temperatures associated with a super-critical reactant supply as indicated in Figure 8. As the heat transfer characteristics of all fluorocarbons are quite similar and the viscosity levels acceptable, the choice was based on cost. Using this criteria, the current prices suggested FC-40 for low pressure operation and FC-77 for the higher pressure operation.

3.7 Fuel Cell Powerplant Flight Instrumentation and Control Information

Fuel cell powerplant flight instrumentation and control requirements were defined in support of the Phase B study contractors. The following list was provided as a recommendation for the minimum number of parameters to be monitored:

- . Stack exit temperature - either hydrogen or coolant
- . Voltage
- . Current
- . Hydrogen condenser exit temperature.

The information shown in Figure 9 and 10 was provided to define the instrumentation and controls required to thoroughly analyze and control powerplant performance. This information may be interpreted as representing a maximum instrumentation and control requirement from which rational decisions may be made regarding particular fuel cell/space vehicle applications.

As a result of these studies and discussions with NASA, MDAC, and NR, definition of the NR and MDAC fuel cell powerplant electrical schematics were completed. These schematics are shown in Figures 11 and 12.

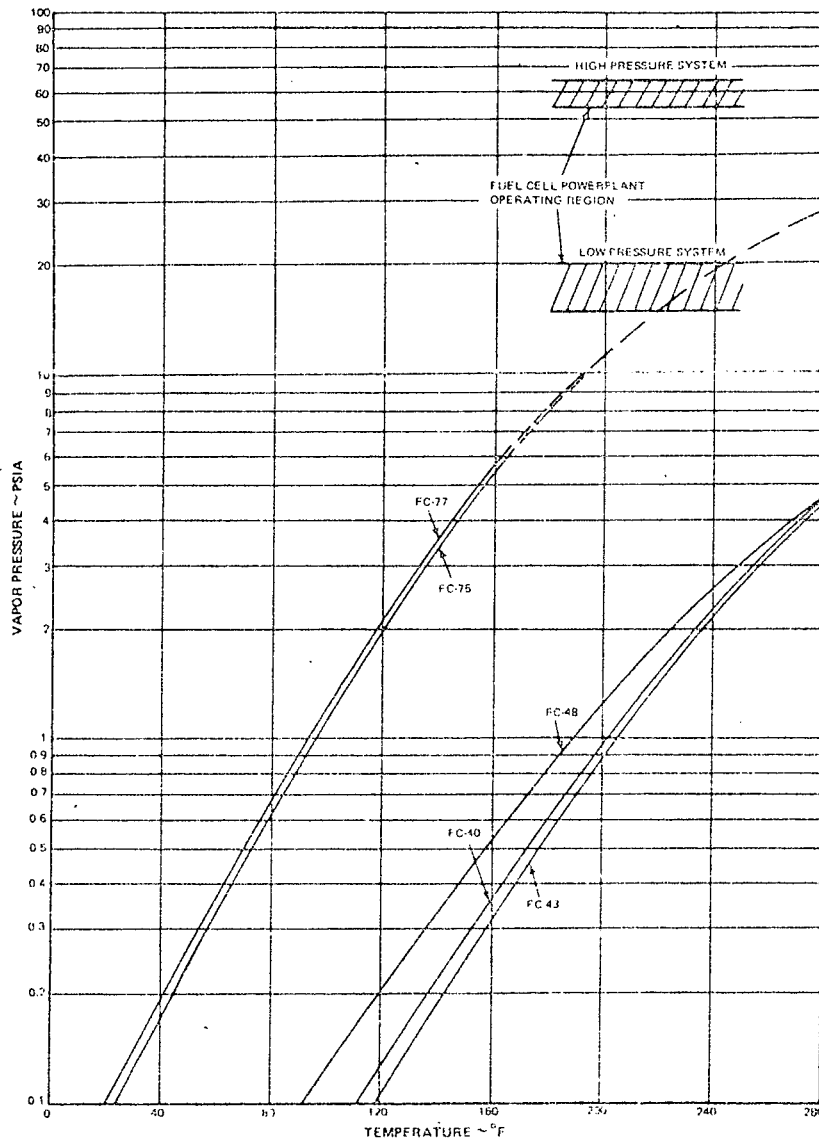

Figure 8 - Vapor Pressure of Fluorocarbon Coolants

WHERE READ OUT

MEASUREMENT/ FUNCTION	WHERE READ OUT			WHY REQUIRED	USAGE IDENT- IFICATION	SIGNAL CHAR- ACTERISTICS	MISSION PHASE APPLIC- ABLE	SIGNAL TYPE
	FLIGHT RE- CORDER*	COCK- PIT	GROUND CHECK- OUT EQUIP.					
Volts (Powerplant)**	Yes	Yes	Yes	Pre-flight go - no go, post flight analysis, restart go - no go, trim	Display record	Continuous to C/P, sample to recorder	All	Analog
Volts (Bus)**	No	Yes	No	Recommended for pilot usage depends on bus arrangement	Display	Continuous	All	Analog
Amps (Gross)	Yes	No	Yes	Shows SUSTAINING HEATER cycling, basis for trim	Record	Sample to recorder	All	Analog
Amps (Net)**	No	Yes	No	Recommended for pilot usage depends on bus arrangement	Display	Continuous	All	Analog
Water Separator Temperature	Yes	Yes	Yes	To indicate need for open cycle manual override	Display	Continuous to C/P, sample to recorder	All	Analog
Stack In Temperature	Yes	No	Yes	Basis for trim, post-flight analysis, pre-flight checkout	Record	Sample to recorder	All	Analog
Stack Out Temperature	Yes	Yes	Yes	For open cycle heat removal override	Display	Continuous to C/P, sample to recorder	All	Analog
Radiator Return Temp.**	Yes	No	Yes	Post-flight analysis	Record	Sample to recorder	All	Analog
Regulated Pressures (H ₂ and O ₂)	No	No	Yes	Pre-flight go - no go	Display on ground equip.	Sample to recorder	Pre-launch	Analog
Reactant Flows (H ₂ and O ₂)**	Yes	No	Yes	Probably provided by vehicle, indicates open cycle on, indicates purges on, indicates plumbing leaks	Record	Sample to recorder	All	Analog
Start Complete Indicator	No	Yes	No	Indicate ready for load	Display	Discrete-light	All except postflight	Discrete

*Flight recorder data obtainable by pilot on demand

** Sensor outside powerplant

Figure 9 - Measurements List

CONTROL FUNCTION	WHERE ACTUATED	WHY REQUIRED	USAGE	CONTROL CHARACTERISTICS	MISSION PHASE APPLICABLE	SIGNAL TYPE
Purge Valve Actuation (each)	Powerplant (auto); cockpit (manual)	Pre-flight checkout, automatic during flight	Control	Switch-automatic, automatic off, on	All except post-flight	Discrete
Start-Stop	Cockpit (manual)	Pre-launch, flight, post-flight control	Control	Switch-on, off	All	Discrete
Start Mode Selector	Cockpit (manual)	To select fuel cell or external power for start (external power could be bus power during flight)	Control	Switch-normal, bus	All except post-flight	Discrete

Figure 10 - Control Signal List

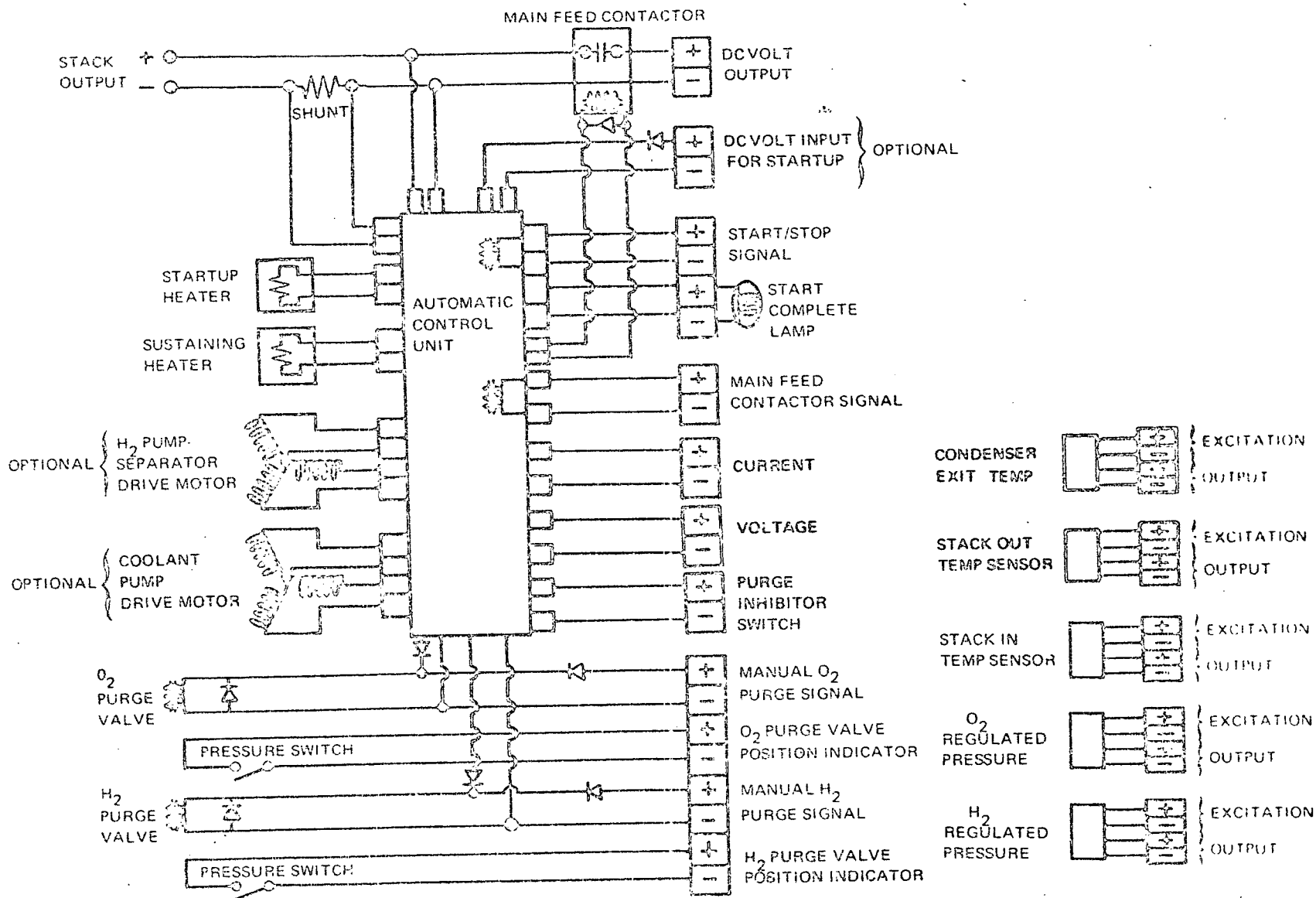

Figure 11 - NR Shuttle Fuel Cell Powerplant Electrical Schematic

PAGE NO. 19

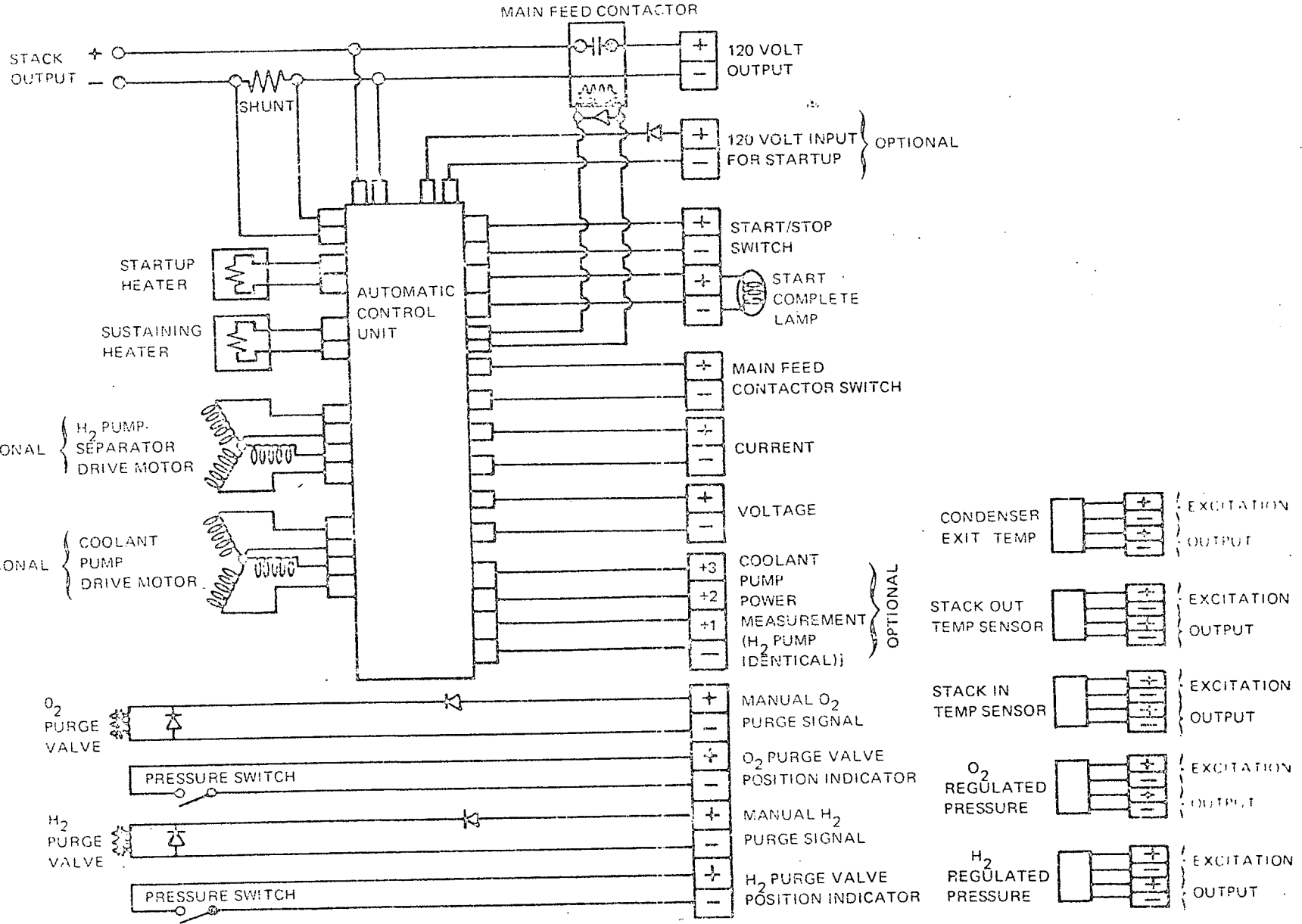

Figure 12 - MDAC Shuttle Fuel Cell Powerplant Electrical Schematic

4.0 DEMONSTRATOR MODEL - 1 (DM-1) SYSTEM DESIGN

A fuel cell powerplant designated Demonstrator Model - 1 (DM-1) was designed for fabrication and testing during the program. The design of the DM-1 was based on EM-1 concepts and incorporated technology advancement features to permit evaluation at the system level of the program fuel cell approaches. A summary of the design parameters of the DM-1 are given in Figure 13.

The DM-1 Space Shuttle Fuel Cell Power System is an electrical power source which produces direct current from the chemical reaction of hydrogen and oxygen. Potable water and waste heat are generated as by-products of the process. Product water is removed by circulating hydrogen through the cells, and excess heat is removed by circulating coolant between the cells.

The DM-1 consists of a reactor stack power section and an accessory section containing a reactant control system, a thermal control system, and a water removal system. An electric driven pump configuration shown in Figure 14 and a gas driven pump configuration shown in Figure 15 were designed for the DM-1.

The reactor stack power section of the DM-1 consists of thirty-two 0.5 ft.² high power density cells. For high pressure operation at 60 psia system operating pressure, gaseous hydrogen and oxygen are provided to the reactor stack through a coupled regulator which maintains constant and equal pressure in the stack reactant passages which supply gas flow proportional to the electrical demand. For low pressure operation at 20 psia system operating pressure, the coupled regulator is bypassed and reactant pressures are controlled by modified Apollo regulators. An accumulator equalizes the coolant and reactant gas pressures. Reactant gas scrubbers are used to remove carbon dioxide from the incoming gases.

Thermal control is maintained by an inert fluorocarbon coolant which is circulated through the power system and simulated spacecraft radiator by either Apollo motor driven gear pumps or an oxygen driven pump. An Apollo thermal control valve provides automatic operating temperature control of the reactor stack by varying the amount of coolant flow to the simulated radiator. A sustaining heater maintains normal reactor stack operating temperature at low power.

Voltage	28 VDC nominal
Rated Power	5.0 KW
Peak Power	10.0 KW
Reactant Supply Pressure	20-1000 psia
Reactant Purity	Fuel Cell grade and Propulsion grade
Startup Time	15 Minutes Max.
Shutdown Time	Instantaneous
Heatup Rejection	Simulated Spacecraft Radiator
Operating Life	2000 Hours Minimum

Figure 13 - DM-1 Design Parameters

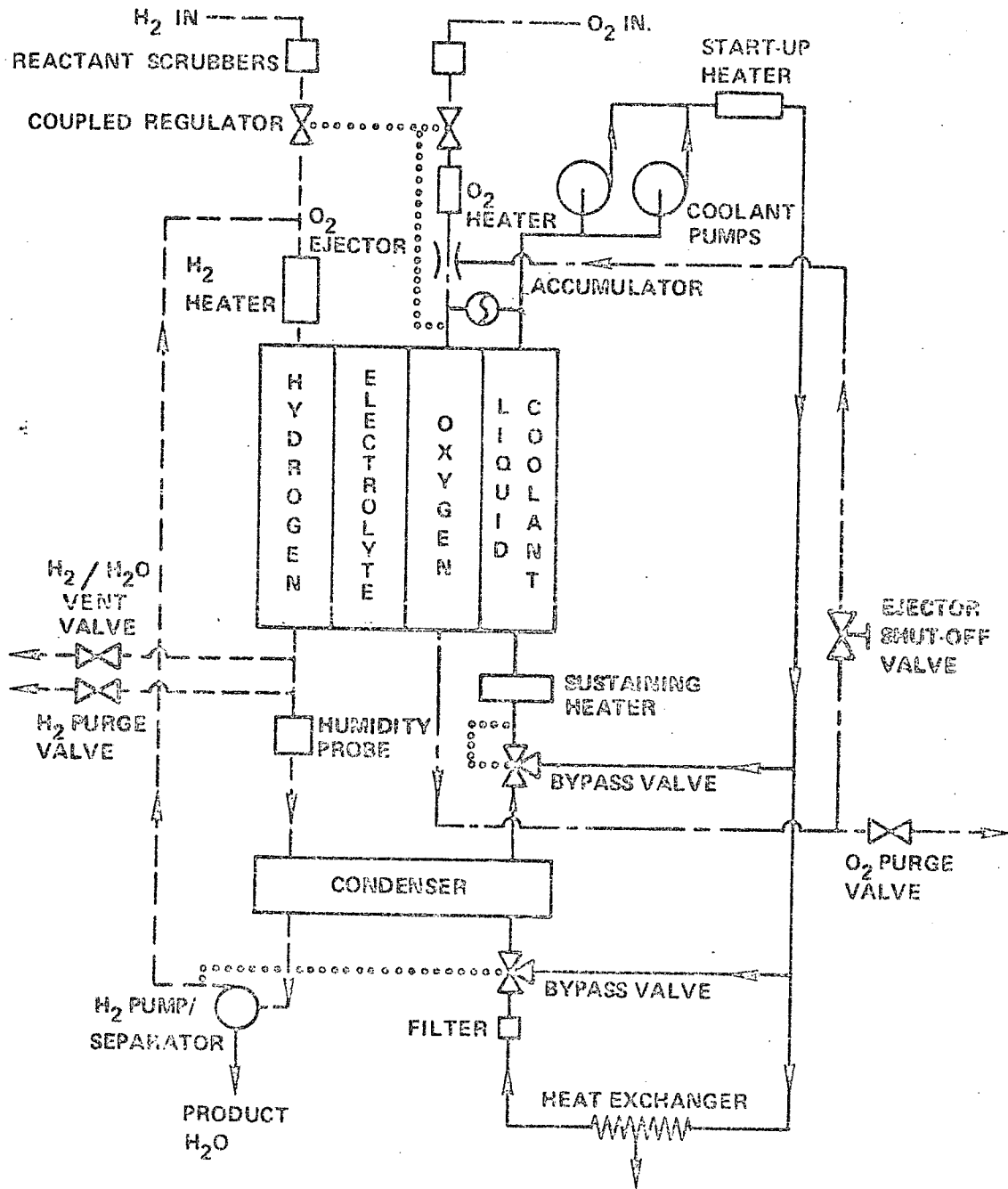

Figure 14 - DM-1 Powerplant Flow Schematic Electric Driven Pump Configuration

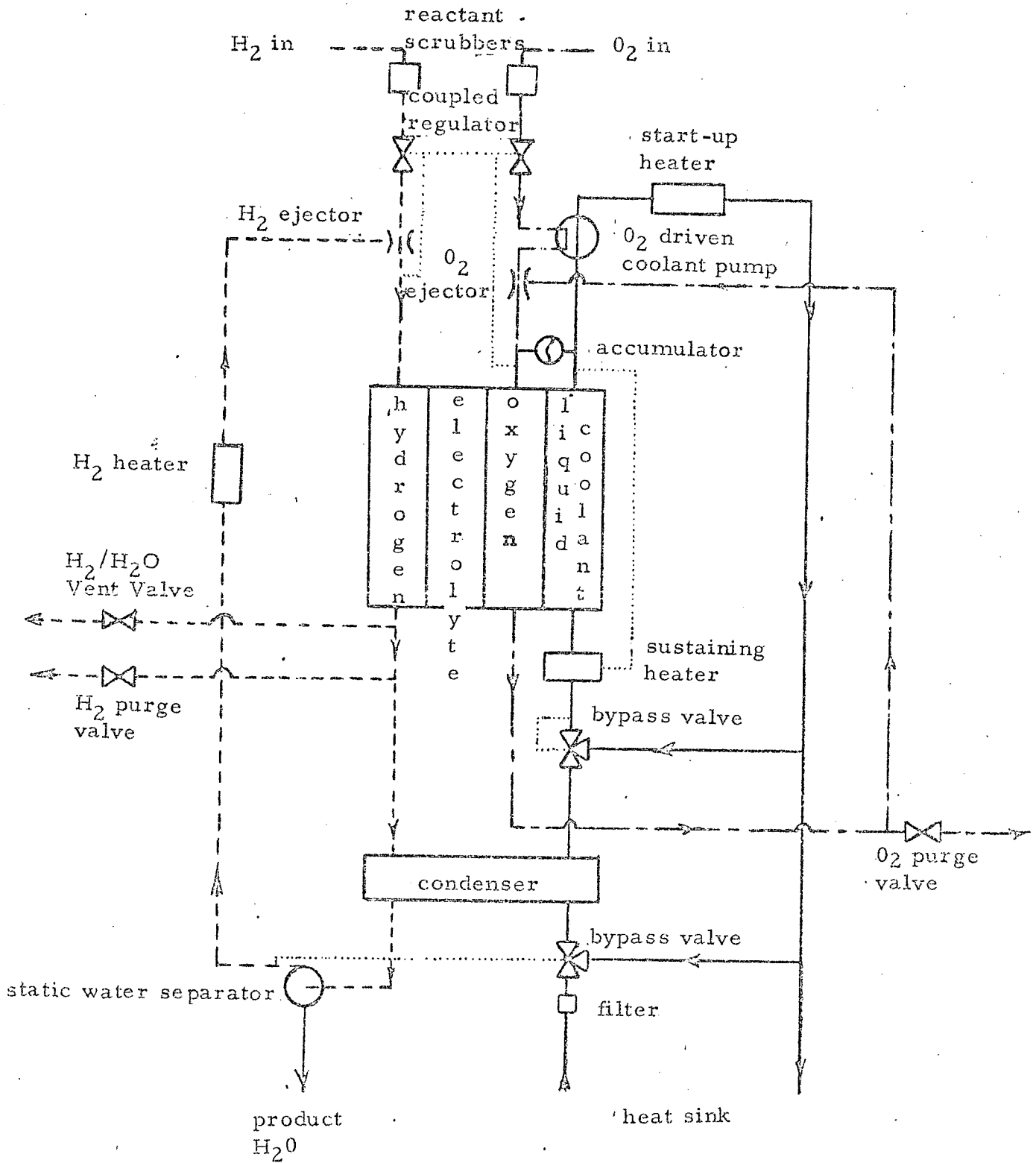

Figure 15 - DM-1 Powerplant Flow Schematic Gas Driven Pump Configuration

A circulating flow of hydrogen in excess of the instantaneous demand of the fuel cell is maintained by an Apollo motor driven pump or hydrogen ejector to carry product water away from the cells. The water vapor bearing hydrogen stream is passed through a condenser where the water vapor is condensed to a liquid. This liquid is then removed by a centrifugal separator which is an integral part of the hydrogen pump or by a static water separator. Electrolyte concentration within the reactor stack is controlled by the amount of water removal from the recirculating hydrogen stream. This is determined by the condenser exit temperature which is controlled by an Apollo thermal control valve which varies the amount of coolant flowing from the radiator.

An oxygen driven ejector is included to recirculate oxygen through the reactor stack. This ejector provides humidification of the oxygen inlet ports and distributes inerts accumulated between purges evenly throughout the reactor stack, increasing the time interval between purges. An oxygen ejector shutoff valve is included to provide the option of operating with or without recirculation. Apollo oxygen and hydrogen purge valves are used intermittently to vent accumulated inerts from the reactant gas passages. An additional purge valve is included in the hydrogen recirculation system to provide water removal by direct venting of hydrogen. This valve is used to simulate those portions of the Space Shuttle mission when the spacecraft radiator is inoperative and unable to provide coolant to the condenser.

The DM-1 Power System Design Report, PWA-4389, provides a detailed description of the individual components included in the DM-1 power system. The Design Report also contains a more detailed description of the system operating characteristics.

5.0 DEMONSTRATOR MODEL - 1 (DM-1) FABRICATION, ASSEMBLY AND TEST

5.1 DM-1 Fabrication and Assembly

The DM-1 fuel cell powerplant was constructed initially in the electric pump configuration described previously. Provisions were made in the construction of the powerplant for conversion to the gas driven pump configuration in accordance with the test plan. Thirty-two of the 0.5 ft² active area high power density cells shown in Figure 16 were assembled into a reactor stack using magnesium cooling plates, stainless steel honeycomb end plates, insulators and tie rods. Figure 17 shows the complete DM-1 stack with individual voltage leads, coolant plate thermocouples and tie rod strain gages. Figure 18 shows the stack and accessory sections assembled together as the DM-1 powerplant.

5.2 DM-1 Testing

The following is a condensation of the DM-1 testing. A complete description of system testing is given in System Test Report, PWA-4409.

An existing sea level test facility was used for the test of the DM-1 powerplant. The test stand provided reactant gases to the powerplant interface, contained a radiator for rejection of powerplant waste heat and provided variable electrical load banks. Various test stand systems were instrumented to obtain data to supplement that monitored by the facility Automatic Data Acquisition and Recording (ADAR) system. In addition to recording data, the computer controlled ADAR system monitored selected DM-1 operating parameters and had the capability of initiating an automatic shutdown in conjunction with the powerplants start/stop controller if any of these parameters exceeded predetermined limits.

The test stand had two separate oxygen supply systems either of which could supply the DM-1. One system supplied fuel cell grade oxygen and the other supplied propulsion grade oxygen. Carbon dioxide scrubbers were installed in the stand hydrogen and oxygen systems before the powerplant interface. The test stand also contained a nitrogen system which could supply nitrogen to both the powerplant reactant systems for inerting after shutdown. The test facility radiator consisted of a water-to-powerplant coolant system heat exchanger. The powerplant radiator return temperature was controlled by varying the water flow to this heat exchanger. The load bank system consisted of several individual load banks connected electrically in parallel with the powerplant, with knife switches installed in each parallel leg. Spike power transients could be performed between various power levels by opening and closing the knife switches as desired.

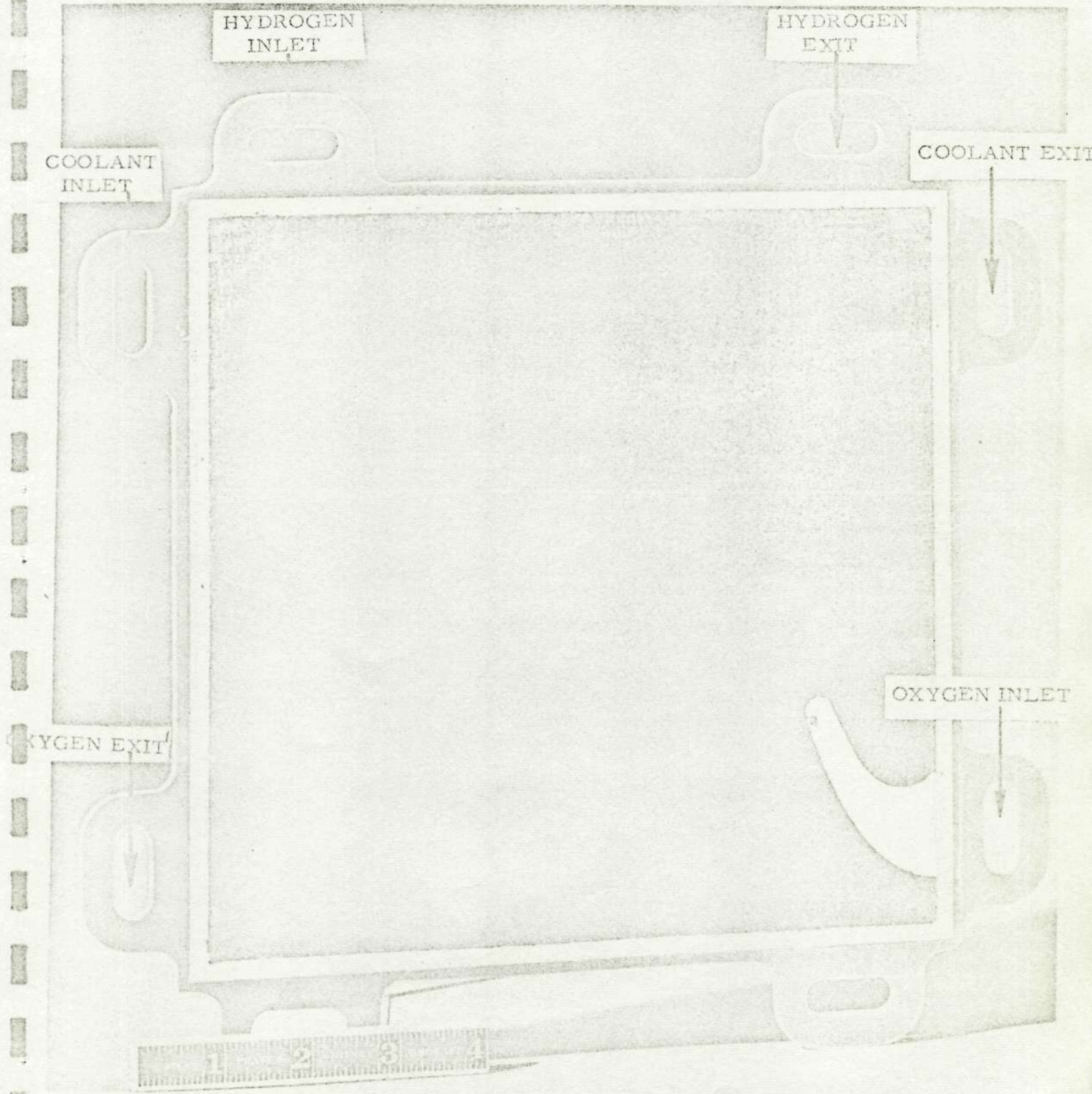

Figure 16 - High Power Density Cell

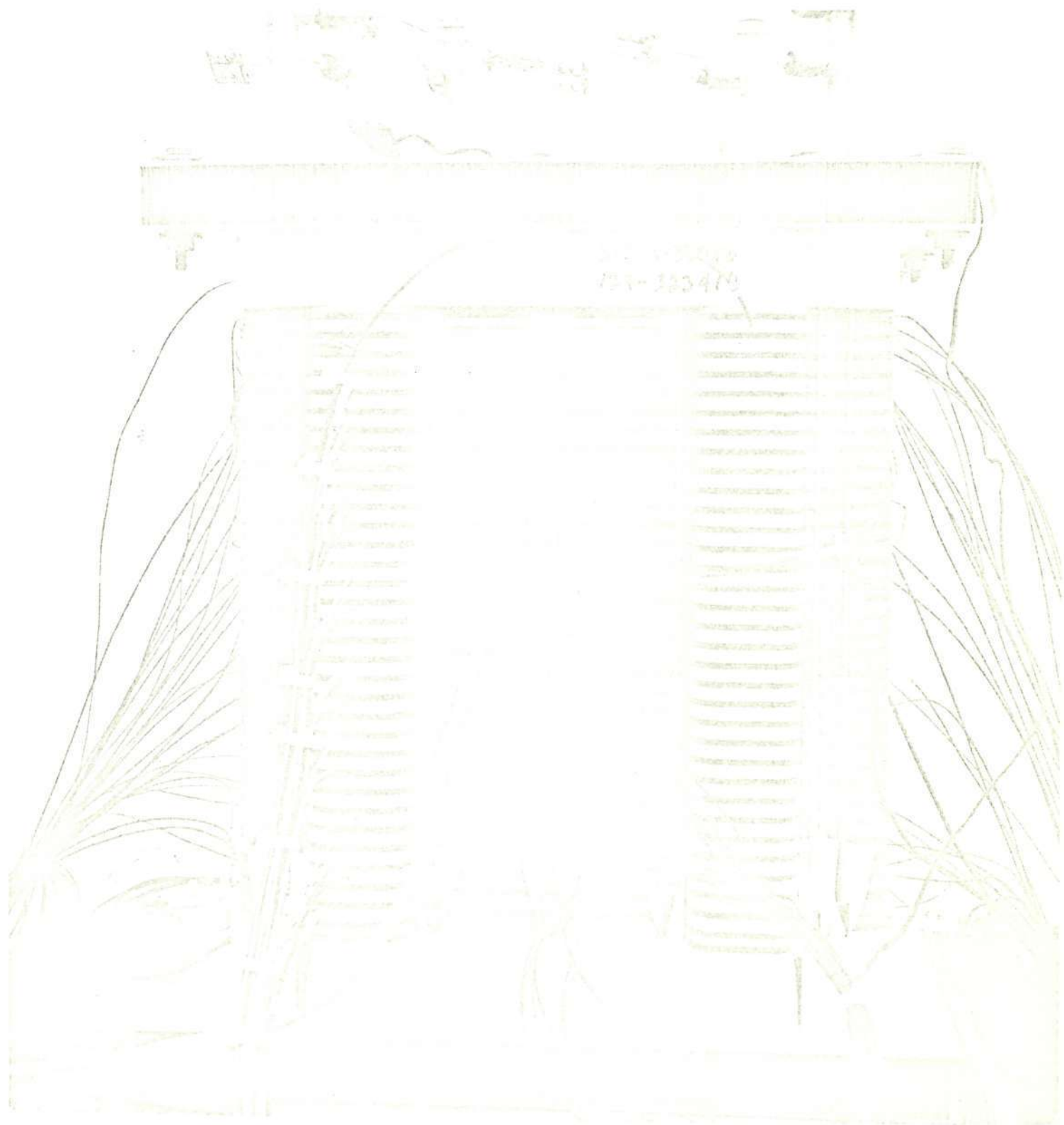

Figure 17 - Complete DM-1 Fuel Cell Stack



Figure 18 - DM-1 Power System

The test stand was equipped with safety devices such as a fire alarm, ventilation system failure alarm, and devices which monitored four critical powerplant operating parameters. Activation of any of these alarms would automatically shut down the powerplant. If automatic shutdown was initiated by the alarms above or by the ADAR monitoring system, the powerplant reactant systems were automatically purged with nitrogen.

The DM-1 powerplant was delivered to test on April 26, 1971 and installation and instrumentation checkout was completed.

The DM-1 powerplant performance and endurance test was planned for four different configurations.

1. Low pressure (20 psia), all electric pumps.
2. High pressure (60 psia), all electric pumps.
3. High pressure (60 psia), electric hydrogen pump and oxygen-driven coolant pump.
4. High pressure (60 psia), hydrogen ejector and oxygen driven coolant pump.

A test plan of the planned specific tests on each of the configurations is shown in Figure 19. Whenever the powerplant was not running one of these tests, an endurance profile shown in Figure 20 was planned. A cumulative total of 2000 hours of operating life was the goal for the four configurations.

Automatic Data Acquisition and Recording (ADAR) programs were prepared and checked out. The system provided powerplant operating data either on command or at preset intervals. In addition, a computer monitoring routine was established for unattended powerplant operation. This routine scanned electric parameters at prescribed intervals and compared the data to preset limits. If an out-of-limits condition was noted, a powerplant shutdown was initiated automatically.

DM-1 TEST PLAN

	<u>Conf. 1</u>	<u>Conf. 2</u>	<u>Conf. 3</u>	<u>Conf. 4</u>
Bootstrap Start	X	X	X	X
Steady State Performance	X	X	X	X
Spike Power Transients	X	X	X	X
*Voltage Regulation	X	X	X	X
*Reactant Consumption	X	X	X	X
Heat Loss		X	X	X
Manifold Condensation Investigation		X		
Open Cycle H ₂ O Removal	X	X		X
O ₂ Recirculator Effectiveness		X	X	X

*Determined analytically from data obtained during steady-state and transient tests.

Figure 19 - DM-1 Test Plan

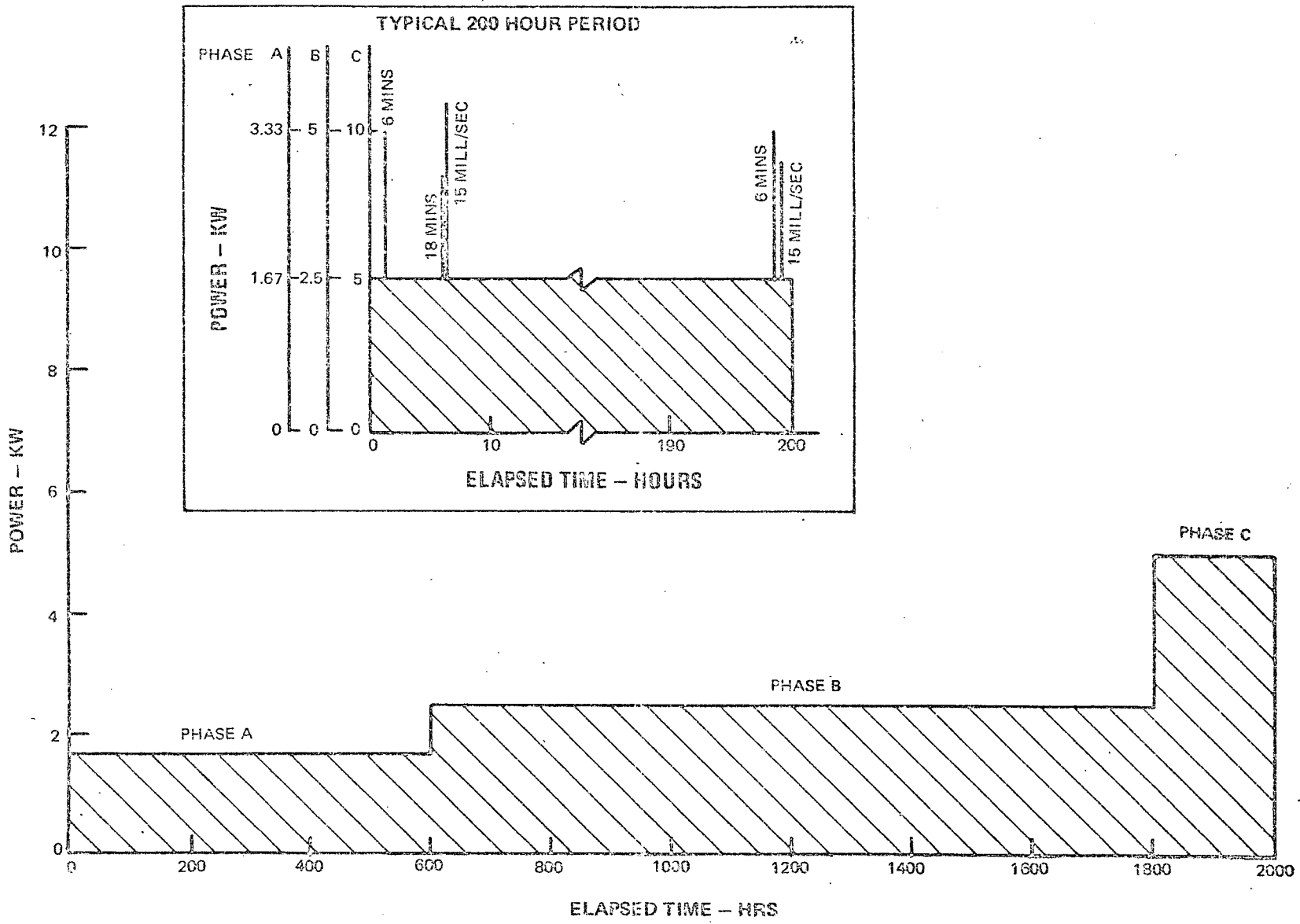

Configuration 1 (low pressure reactant supply, all electric driven pumps) testing was started on May 4, 1971 and completed on May 10, 1971. During this time the following planned evaluations were completed:

- . Seven bootstrap starts
- . Sixty-one load hours
- . Steady-state performance from 0.58 kw to 5.1 kw
- . Spike transients to 8.4 kw
- . Open cycle water removal at 3 kw for 30 minutes with a radiator return temperature of 161°F

The DM-1 powerplant was then converted to Configuration 2 (high pressure reactant supply all electric drive pumps, oxygen recirculation, oxygen co-flow with coolant) on May 11, 1971. On May 19, the oxygen system was modified to counter-flow configuration as difficulties were experienced with the ejector system. Testing in this configuration (standard PC8B configuration) continued completing the following planned evaluations:

- . Four bootstrap starts, one external power start
- . 411 load hours
- . Steady-state performance from 0 net to 5.5 kw (co-flow, counterflow and no oxygen ejector)
- . Spike transients to 10 kw
- . 10 kw peak power for six minutes
- . 8.5 kw peak power for eighteen minutes
- . Open cycle water removal at 3 kw for sixty minutes with a radiator return temperature of 152°F

Testing of the DM-1 in the high pressure, all electric drive configuration with oxygen counter flow to the coolant continued. Difficulties were encountered during oxygen recirculation testing. On 3 June 1971, an externally controlled heater was installed on the oxygen secondary loop to eliminate condensation suspected of causing cell performance losses. This eliminated the associated difficulties.

On 7 June 1971, at 610 total load hours, low performance of Cell #32 caused an automatic shutdown. Investigation showed that the hydrogen pump pinion gear had worn excessively and that the plastic gear material had plugged the hydrogen inlet ports of Cell #32. The pump was rebuilt and the cell stack was cleaned. The powerplant was restarted and although a severe performance loss was exhibited, operation continued with performance slowly improving until 25 June 1971 when Cell #4 would no longer hold a load. A cell stack check indicated a hydrogen to oxygen gas leak so the test was terminated. During this test of Configuration II, 9 bootstrap starts, 678 load hours, steady-state performance to 5.5 kw, peak power at 8.5 kw for 18 minutes, spike transients to 10 kw, open cycle water removal, and a 4500 amp-hour purge interval were accomplished. Automatic, unattended operation for prolonged periods with the powerplant under facility computer monitoring was also demonstrated.

The Apollo hydrogen pump pinion gear failure was determined to be the result of operation at below design loads causing gear wear due to "chattering". The Apollo installation hydrogen loop pressure drop is approximately 12 in. H₂O. The DM-1 loop was approximately 4 in. H₂O. A restriction was placed in the DM-1 hydrogen loop matching it to Apollo conditions. Subsequent measurements on the pinion gear were normal.

Teardown inspection of the stack revealed that the stack had been subjected to an overpressure condition. However, review of the test data recorded during steady-state operation did not show such an incident. A series of hydrogen, oxygen and coolant overpressure tests were performed on identical cells. The physical condition of the DM-1 cells was duplicated by a 45 psi hydrogen overpressure. Bench testing of the regulator under simulated powerplant conditions did produce a pressure imbalance of 19 psi under certain conditions of depressurization. It was concluded from this that this particular coupled regulator (breadboarded with two Apollo regulators modified to provide remote sensing) produced a temporary pressure imbalance, permanently distorting the electrodes causing a performance loss and uneven heat transfer and current density.

6.0 TECHNOLOGY ADVANCEMENT - HIGH POWER DENSITY CELL

6.1 Task Objective and Approach

Design and development of a high power density cell to meet NASA goals was a major task of this program. The objective of the task was to extend the cell operating life and energy delivery capability over that demonstrated by the standard P&WA PC8B sinter-screen cell. The approach to meeting these goals of increased life and energy delivery capability was to incorporate the high power density cell concept established in a previous P&WA program into the cell design. State-of-the-art magnesium coolant plates, glass fiber unitizing frame materials, asbestos cell matrix and platinum-palladium catalyst composition were included in the cell design for evaluation in the high power density configuration.

A parallel effort to improve the state-of-the-art was included in the program. This effort consisted of advancing the design and evaluation of nickel foil and plastic frame coolant plates, plastic unitizing frames, and reconstituted asbestos matrix.

6.2 High Power Density Cell Description

The conventional low temperature base electrolyte cell used in the P&WA PC8B programs consists of a catalyzed screen cathode, a fuel cell grade asbestos matrix, and a catalyzed nickel sinter anode. These components are assembled using epoxy impregnated glass fiber laminates built up into a unitized hard frame structure. The cathode/matrix/anode structure is filled with aqueous potassium hydroxide electrolyte. In normal operations of a fuel cell powerplant, the concentration of the electrolyte solution will vary as a function of the operating power range. Implicit with the concentration change is a volume change of the solution which must be accommodated in the cell structure. In the conventional cell this is accomplished in the sintered anode.

The high power density low temperature base electrolyte cell consists of a catalyzed screen cathode, a fuel cell grade asbestos matrix, a catalyzed screen anode and uncatalyzed sintered nickel electrolyte reservoir plate (ERP). These components are unitized using epoxy impregnated glass fiber laminates in the same manner as the conventional cell. The cathode/matrix/anode/ERP structure is filled with aqueous potassium hydroxide electrolyte. In the normal operation of the fuel cell powerplant over its operating power

range, electrolyte volume changes similar to the conventional cell will occur and must be accommodated. The ERP serves this function. As the electrolyte concentration changes, electrolyte will transfer back and forth between the ERP and the matrix as required. The electrolyte interfaces in both cathode and anode remain fixed. The interface movement as a result of volume change takes place in the ERP.

The high power density cell concept offers two major advantages over the conventional cell. The first is that the functional electrolyte interfaces can be maintained closer together (separated only by the matrix thickness) and at a constant separation. This results in improved performance over the conventional cell at any given condition since minimum separation of the electrolyte interfaces gives minimum internal resistance losses. Figure 21 shows performance comparison of these cells. The second advantage of the high power density cell is that additional electrolyte inventory can be included without incurring a performance penalty. This extends the cell operating life by accommodating greater amounts of potassium carbonate formed from carbon bearing constituents of the reactant gases and from corrosion products of the cell frames.

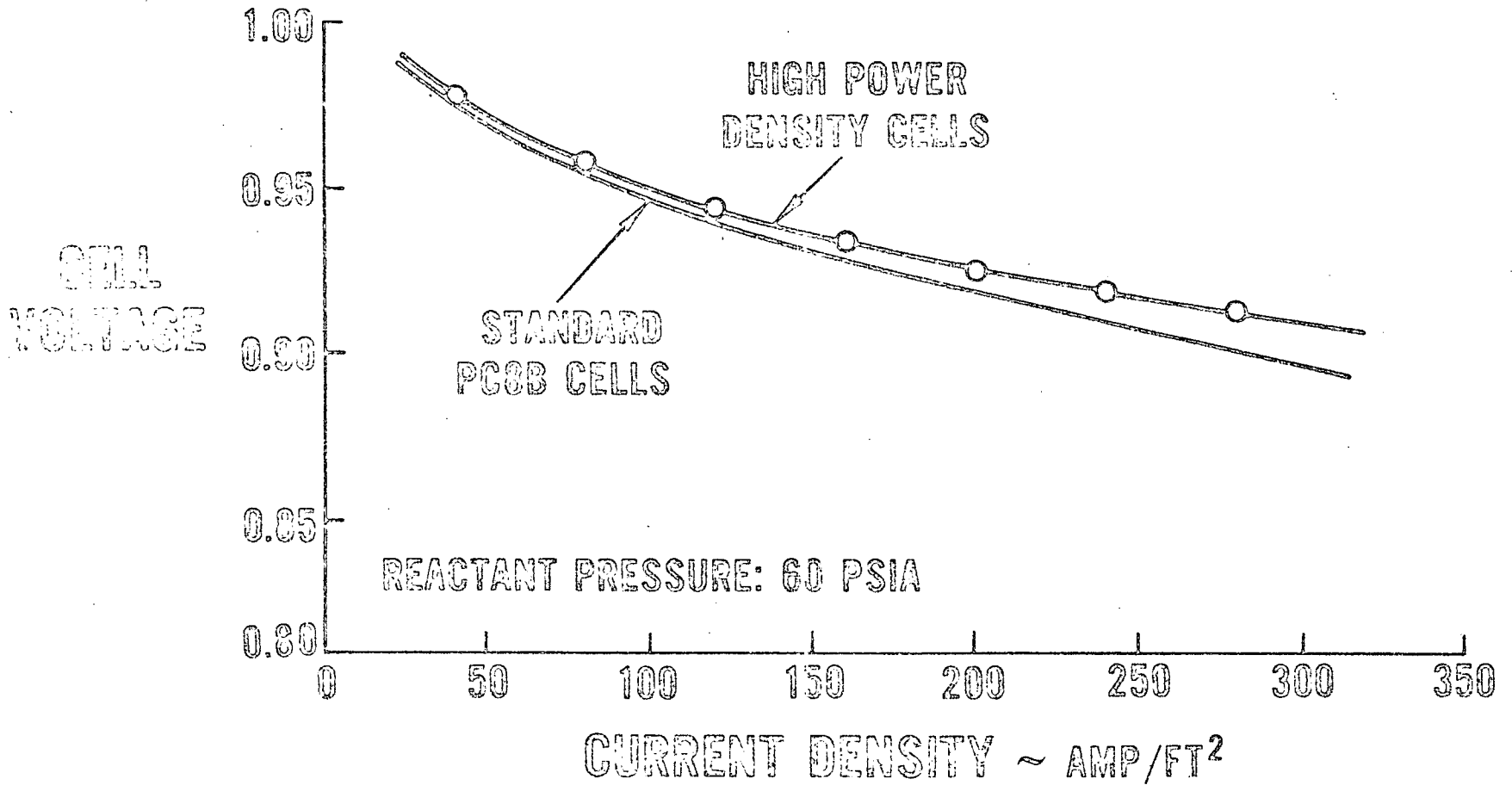

Figure 21 - Performance Comparison of High Power Density and PC8B Cells

6.3 Evaluation of the High Power Density Cell

A series of single cell and multicell tests was conducted during the program to evaluate the high power density cell. The testing was conducted in accordance with Program Plan, PWA-3985A, and the Single Cell and Small Stack Test Plan, PWA-3986D. Design support information tests and operating life demonstration tests were included.

Details of the tests are presented in the Single Cell and Small Stack Test Report, PWA-4310. A brief summary of the tests is presented below.

6.3.1 Evaluation of Propellant Reactants (Single Cell-21, SC-21) - Details of this test are presented in PWA-4260, Reference: Single Cell and Small Stack Test Report, PWA-4310.

The objective of cell test SC-21 was to determine the performance variation and purge requirements of an operating cell when supplied with oxygen containing simulated propellant reactant inerts.

The possibility of using propellant grade oxygen for Space Shuttle applications prompted a concern for a suitable purge schedule to maintain an acceptable performance level over the entire power range. A test was conducted to determine the effect of oxygen inert concentration on High Power Density (HPD) cell performance.

Oxygen inert testing was conducted on a single cell test unit from 15 January 1971 to 21 January 1971 while the cell was operating at 60 psia, 190°F cell inlet temperature with open cycle high purity hydrogen saturated to a temperature of 166°F at the cell inlet. Inert levels from 0 percent to 80 percent (by volume) were obtained by continuous mixing of nitrogen with the oxygen supply.

Two methods were utilized to evaluate the effect of inert concentration on performance; one simulating an oxygen recycle system (as would be the case with an oxygen ejector in the system) and the other the present dead-ended oxygen system. The recycle system was simulated by continuously venting oxygen at a constant 82 percent utilization, while increasing amounts of nitrogen were introduced to the oxygen supply at steady-state loads from 50 amps (100 ASF) to 500 amps (1000 ASF). The dead-ended test was performed only at 200 amps (400 ASF).

The data was used to determine the performance variation and the required purge interval, for both the dead-ended and oxygen recycle systems, as a function of oxygen gas purity.

In the load range from 0 to 400 ASF, the performance decay was a function of the inert content within the cell and was independent of load.

In a recycle oxygen system with an inlet inert level of 5000 ppm, the estimated allowable operating time without purge was 90 amp-hours, based on a decay of 0.010 volts/cell between purges.

In a dead-ended oxygen system with an inert level of 5000 ppm, the estimated allowable operating time without purge was 18 amp-hours, based on a 0.010 volts/cell decay between purges. This compared well with the average cell experience during previous powerplant and multicell stack testing.

6.3.2 Operating Life Test (Single Cell-51, SC-51) - Details of this test are presented in PWA-4245, Reference: Single Cell and Small Stack Test Report, PWA-4310.

The objective of cell test SC-51 was to establish the operating life and effect on electrolyte carbonate level of hydrocarbon contaminants typical of the propellant grade gas supply.

Four single cell tests were conducted on the initial design of the high power density cell using PC8B powerplant configuration materials. The test program was designed to map the effects of operating temperature and current density on the life characteristics of the cell and to determine the effect of hydrocarbon contaminants on electrolyte carbonate level. The hydrogen gas used was passed through Pd-Ag separators and contained less than 1/2 ppm impurities. The oxygen gas was passed through test stand purifiers (carbon dioxide scrubbers). The resultant gas contained 6 to 10 ppm of hydrocarbons which were allowed to enter the cell for evaluation. A common load profile was run on each cell. The test conditions and results are summarized below:

<u>Test #</u>	<u>Time</u>	<u>Cell Temp.</u> <u>°F</u>	<u>Current Density</u> <u>ASF</u>	<u>Result</u>
1	10770	160	75	Terminated
2	3579	160	200	Stand Failure
3	2260	200	75	Cell Failure
4	1401	200	200	Cell Failure

Each of the cells exhibited no decay in performance from their original operating level. The performance of Cell #1 continued to rise until 4300 hours when it began to decrease gradually. The test was continued beyond the planned 5000 hours on an in-house program. At approximately 10,000 hours, the cell was still above its initial performance.

The performance of Cell #2 continued to rise until the failure time indicated. The failure occurred during automatic unattended operation when the test stand hydrogen flow system developed a restriction severely limiting the means of product water removal from the cell.

The performance of Cell #'s 3 and 4 also continued to rise until the times indicated. Both failures were due to electrical shorting caused by hydrogen flow tubes at the cell ports. A subsequent redesign of the cells eliminated these tubes entirely, thereby eliminating the failure mode. Carbonate analyses of the three failed cells were within predicted values.

It is concluded from these tests that the high power density cell demonstrated the capability for 5000 hours of operation without performance loss. It is recommended that follow-on program activity determine the cause of cell performance rise with time to enable realization of higher performance levels from the beginning of life.

6.3.3 Multicell Operating Life Test (Multicell-11A, MC-11A) - Details of this test are presented in PWA-4256, Reference: Single Cell and Small Stack Test Report, PWA-4310.

The objective of multicell operating life test MC-11A was to conduct performance and endurance tests on full size high power density cells to evaluate EM-1 design variables.

A multicell stack was assembled early in the program to evaluate three HPD (High Power Density) cell configurations. Variables being evaluated were high catalyst loaded cathodes for improved performance and a thicker asbestos matrix for improved cell structural characteristics.

The test stack was assembled using standard PC8B magnesium coolant plates and 6 high power density unitized electrode assemblies (UEA's) with an extended matrix design. In this design, the asbestos matrix extended into the glass fiber hard frame beyond the electrode screens. Two of the electrode assemblies were to the standard high power density cell configuration, two had a thicker matrix and two had a thicker matrix and a high catalyst loaded cathode.

From 8 October 1970 through 5 January 1971, Rigs 37804-1 and -2 accumulated a total 1918 load hours operating at 60 psia, 190°F inlet temperature, and 32 percent KOH in the recycle hydrogen mode. An endurance load of 100 amps (200 ASF) was maintained through 1160 load hours, and lowered to 50 amps (100 ASF) for the remainder of the evaluation.

Test Rig 37804-1 was shutdown at 430 load hours on 30 October 1970 to remove the two higher loaded cathode cells that had experienced a high performance degradation and periodic oxygen purge sensitivity.

Testing resumed on 3 November 1970 with the remaining four cells, designated Rig 37804-2. A gradual voltage decrease began after the restart at 430 hours. At approximately 820 load hours, the coolant pressure, normally 1.5 psi less than reactant pressure, was raised to and maintained at 5 psi over the reactant pressure through final shutdown in an attempt to reverse the voltage decrease. The immediate response was an increase in performance on all four cells but the decay characteristics of the two thicker matrix cells was unchanged, necessitating a decrease of the endurance load to 50 amps (100 ASF). At 1918 load hours, testing was terminated.

As a result of this testing it was concluded that the extended matrix resulted in swelling of the glass fiber frame and hence a loss of proper electrical contact during cell operation. The non-extended matrix design should be retained to eliminate frame swelling. With a stable UEA frame, the HPD cell will not experience any decay in 2000 hours of operation.

A high performance decay and purge sensitivity was noted as a result of the high catalyst loaded cathode. Further investigation of these results is recommended for a follow-on program.

The performance characteristics of the 0.015 inch thick matrix cells could not be evaluated because of the frame swelling. Additional testing will have to be performed to complete the evaluation.

6.3.4 Multicell Operating Life Test (Multicell-31, MC-31) - Details of this test are presented in PWA-4311, Reference: Single Cell and Small Stack Test Report, PWA-4310.

The objective of multicell operating life test MC-31 was to evaluate the DM-1 cell configuration life characteristics to the Space Shuttle power profile.

Rig 37861 -1 was assembled with six high power density cell assemblies of the DM-1 configuration and operated on propellant grade reactant gas to demonstrate performance and life characteristics. The power profile, purge schedule and cell operating conditions were chosen to reflect Space Shuttle operating conditions.

From 10 February 1971 to 6 July 1971 the stack accumulated 3266 load hours of which approximately 2820 hours were on propellant grade gas. The endurance operating conditions were at an average cell temperature of 180°F, operating pressure 60 psia, electrolyte concentration of 29 percent KOH/71 percent water. The stack experienced seven shutdowns during this period; six were scheduled and one was caused by a facility power failure at 1411 load hours.

On the restart following the unscheduled shutdown, a performance loss of approximately 37 mv was experienced on each cell in the stack. The performance of all cells gradually recovered in 489 hours and then stabilized at about 1900 load hours at a level of 10 mv per cell higher than before the shutdown. The performance level remained unchanged for the remainder of the test. At 3266 hours, the performance of Cell #3 became unstable. The stack was shutdown and a stack check confirmed reactant gas crossover which necessitated test termination.

The cause of the performance loss on the stack following the unscheduled shutdown was investigated by simulating the automatic shutdown procedure and the restart procedure on new high power density single cells. In a normal automatic shutdown electrical load is removed and the reactant systems are switch to nitrogen. The cells remain on reactants unless the reactants are depleted by diffusion or consumption. Review of the data and test equipment indicated that a small electrical load remained on the stack due to the resistance of the load bank. Since the shutdown occurred on a weekend, nitrogen reached the cells gradually as the reactants were consumed and the voltage slowly decayed to zero. Three possible situations could have developed regarding the introduction of nitrogen into the cell stack:

1. Both reactants were depleted at about the same rate, allowing nitrogen on both sides of the cell simultaneously;
2. Oxygen was depleted faster than hydrogen, putting nitrogen on the oxygen side of the cell with hydrogen still on the hydrogen side. This was considered most likely because the oxygen system volume is considerably smaller than the hydrogen system volume;
3. Hydrogen was depleted faster than oxygen putting nitrogen on the

hydrogen side of the cell with oxygen still on the oxygen side.

The test program was designed to simulate these three possibilities. The possibility that the performance loss was because of the restart procedure was also investigated by simulating the endurance rig's startup voltage profile following an automatic shutdown. All of the above tests involved possible electrochemical changes in the electrodes due to varying potentials. No attempt was made to evaluate possible mechanical causes of the performance loss.

None of the tests conducted on the single cells resulted in a performance loss similar to that experienced by the six-cell stack. It was concluded that the performance loss was not due to electrochemical changes in the cell electrodes.

The stack teardown and investigation of the failure which caused test termination confirmed that only Cell #3 exhibited gas crossover. A failure investigation program similar to the one followed for the DM-1 Cell #4 failure (Reference: DM-1 Power System Test Report, PWA-4409) was established. The investigation consisted of a dry nitrogen flow check to determine theoretical hole size, electronic resistance measurements, cross sectional photomicrographs through the failure site, electron microprobe and X-ray diffraction examination of a matrix cross section, chemical wet analysis of cell samples and performance tests on Cell #'s 1, 2, 5 and 6 from the stack (Cell #4 was removed for physical comparison to Cell #3).

Conclusions which were drawn from this investigation and a review of the MC-31 endurance data are summarized as follows:

- . Internal resistance measured higher than that on new cells and sensitivity to coolant overpressure (which in this cell design increases the contact pressure between the electrodes, matrix and coolant plates) indicates a relaxation of coolant plate pin loading with time.
- . Metallic deposits in the matrix were heavier than those in the DM-1 cells. In the cross section samples that were photomicrographed, no metallic bridging across the matrix was noted.

Non-uniform pin loading of this design and the increase in internal resistance probably caused non-uniform heat dissipating and current density contributing to the breakdown of the matrix.

6.4 Advanced Frame, Coolant Plate, and Matrix Evaluation

6.4.1 Plastic Frames - Design and design support testing were initiated early in the program to further investigate the feasibility of unitizing the electrode, matrix and ERP assembly with a plastic frame instead of the glass fiber frame. The epoxy impregnated glass fiber structure has been found to be a contributor to the formation of potassium carbonate in the cell matrix. Although long duration tests (in excess of 10,000 hours) have been conducted with glass fiber frames, replacement of this component with a non-carbonating plastic is desirable to improve cell reliability and extend the cell operating temperature range.

Arylon[®] and Noryl[®] were promising candidates based on potassium hydroxide compatibility tests. Materials tests and testing in full sized cells indicated unacceptable creep characteristics under stacking mechanical loads. Ceria, Zirconia, Asbestos, PKT and glass fillers were selected. Full scale frames with filler levels sufficient to reduce creep to 1 percent or less at 250°F and 1000 psi were brittle and unworkable. A series of molding trials, machining trials and thermal cycling trials and corrosion tests was conducted on different levels of these fillers in the Arylon and Noryl. It was concluded that 30 percent glass filled Noryl was acceptable at least for intermediate life testing.

A series of tool trials was conducted to find a suitable adhesive to bond the cell elements to the plastic frames. AF-126 (a 3-M product) Hypon (Hycar and Epon) and Ethylene Propylene Rubber (EPR) were found to be promising. However, further work on these plastic frames was terminated when it became evident that reducing this concept to practice was beyond the scope of the program.

6.4.2 Electroformed Nickel Foil Coolant Plates - Design support testing investigated the feasibility of replacing the standard magnesium coolant plates with nickel coolant plates. The nickel plates have the advantage of greater latitude in the choice of fuel cell coolant fluids and simplified manufacturing in comparison to the magnesium.

The configuration evaluated utilized an electroformed nickel foil insert bonded to a plastic frame. This configuration was compatible with the previously described plastic frame cell assemblies. In the final developed configuration, the plastic framed coolant plates and the plastic framed cell assemblies would be bonded directly together, eliminating all mechanical seals in the stack.

A sweep flow geometry was selected for evaluation of the nickel foil plates. The standard magnesium plates use a "W" flow geometry where the reactants or coolant enter their respective flow fields at one point from the supply manifold and flow in a "W" pattern to the exit ports. In the sweep flow geometry, the coolant or reactants enter a secondary manifold or plenum from the supply manifold. The secondary manifold extends completely across one end of the flow field. From there the fluids pass across the cell in a single straight pass. The potential advantages offered by this configuration are a lower stack pressure drop, increased inlet porting reducing susceptibility to port plugging and more uniform flow distribution. A design support test program was conducted on the characteristics of the sweep flow geometry. The results are covered in detail in PWA-4168, Reference: Single Cell and Small Stack Test Report, PWA-4310.

Manufacturing of the foil by electrodeposition of nickel on a plexiglass form presented no special problems. Several trials were required to achieve uniformity of the foil on all rib contours and corners. A 0.010 inch thick foil was selected for evaluation.

The plastic frame investigation for the coolant plate was carried on at same time as the plastic frame activities for the cell assembly described in a previous section. Both Arylon and Noryl were used as frame material. The most successful configuration was 30 percent glass filled Noryl bonded to the nickel foil with AF-126 film adhesive. A two cell stack using plastic framed coolant plates completed 160 hours endurance at 150 ASF.

As in the case of the plastic framed cell assemblies, effort on the plastic framed nickel coolant plates was terminated when it became evident that reducing the concept to practice was beyond the scope of the program. It is concluded that the nickel coolant plate offered advantages over the magnesium which should be pursued. It is recommended that follow-on activity in this area be devoted to developing a full sized nickel coolant plate without plastic frames, incorporating the mechanical seals used in the present standard cells.

6.4.3 Improved Asbestos Matrix - An improvement to the "as received" Johns-Manville (J. M.) fuel cell grade asbestos matrix was tried through a reconstituting process suggested by NASA. The process, as adapted by P&WA, consists of shredding the as received asbestos in a water slurry to obtain more uniform fiber sizes and then rematting it. The objective of the reconstituting process was to produce matrices with increased porosity, decreased mean pore size, improved uniformity and increased gas bubble pressure compared to the J. M. asbestos.

Trial pieces of the reconstituted asbestos were made up in various thicknesses. Porosimetry analysis and bubble pressure test results of fabricated samples are presented in Figure 22. A cross section photomicrograph comparing the reconstituted and the "as received" is presented in Figure 23. Examination of the tabulated results and the cross section photo shows that the desired mechanical results were achieved through the reconstituting process.

Performance of 2 inch by 2 inch cells using reconstituted matrices was equivalent to the baseline performance of cells using "as received" fuel cell grade asbestos. Structural tests of the reconstituted matrix showed that its stress-strain characteristics were identical to those of the "as received" matrix.

Based on the results of this task, it is recommended that the reconstituted asbestos matrix be incorporated as standard for all cell designs in the follow-on activities.

PAGE NO. 46

<u>Matrix</u>	<u>Porosity - %</u>	<u>Mean Pore Size - μ</u>	<u>80% Pore Size Range - μ</u>	<u>Bubble Pressure - psi</u>
0.010 in. As Received	52-75	1.1	0.1 - 60	20
0.010 in. Reconstituted	70	0.6	0.1 - 32	55
0.020 in. Reconstituted	70	0.6	0.1 - 32	90
0.030 in. Reconstituted	70	0.6	0.1 - 32	75

Figure 22 - Asbestos Matrix Physical Properties Comparison

PHOTO & WHITNEY AIRCRAFT

1 W 4 A - 400

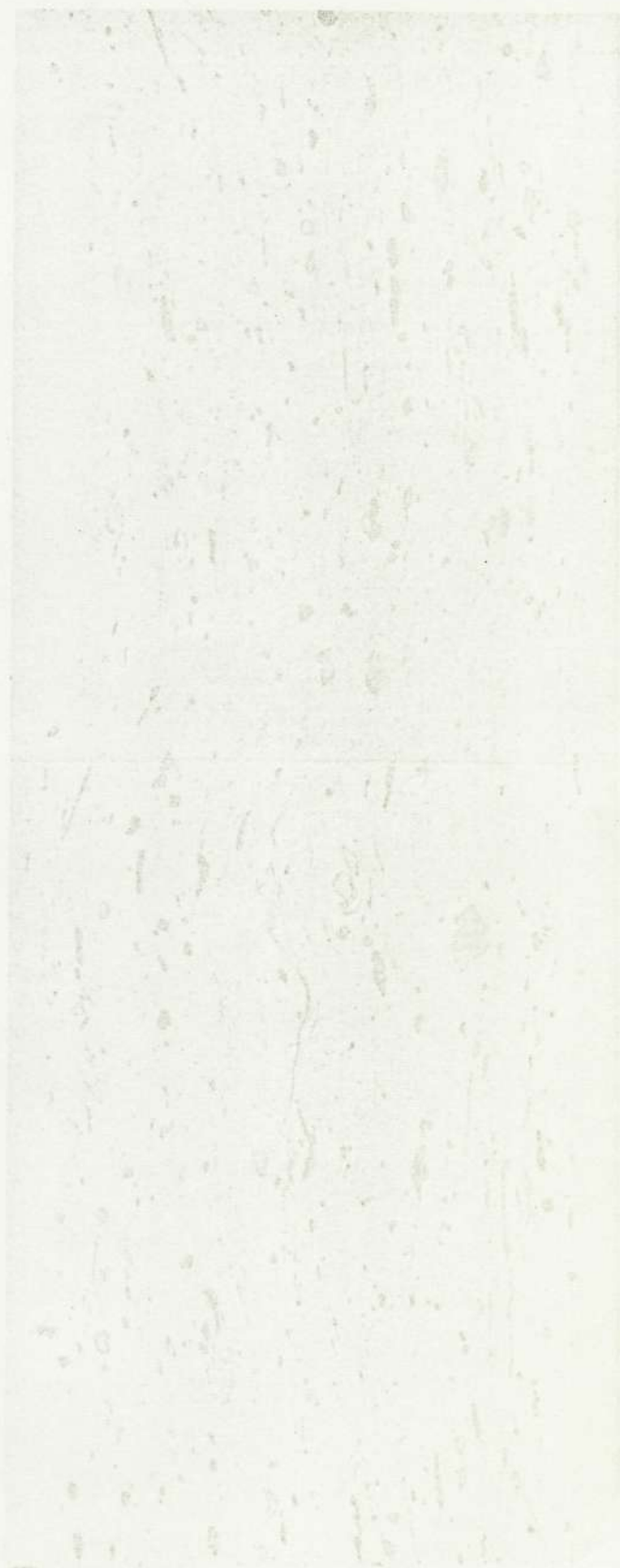

Johns-Manville Corporation Fuel Cell Grade

P&WA Reconstituted

Figure 23 - Asbestos Matrix Material (10 Mil) Cross Section at 200X

7.0 TECHNOLOGY ADVANCEMENT - GAS DRIVEN CIRCULATORS AND STATIC WATER SEPARATOR

7.1 Task Objective and Approach

Design and evaluation of gas driven circulators and a static water separator was a major task of this program. The objectives of the task were to demonstrate feasibility and develop an oxygen driven coolant pump, a hydrogen jet pump and a static water separator for use in a fuel cell powerplant.

7.2 Oxygen-driven Coolant Pump

Proper system operation of the EM-1 or DM-1 fuel cell powerplants requires that a coolant fluid be circulated through the cell stack to remove waste heat produced by the fuel cell reaction. Electrically driven pumps have been used to perform this function in the past. System studies have shown that the pressure energy of the consumed reactant oxygen supplied at approximately 200 psia to a fuel cell operating at 60 psia is sufficient to drive a diaphragm type pump for coolant circulation. One advantage of this pump is that it eliminates an electric motor and inverter thereby reducing parasite power. In a fuel cell powerplant, coolant requirements are proportional to power generation. Another advantage of the oxygen driven coolant pump is that its pumping rate is proportional to the oxygen consumption rate thereby matching it to coolant flow requirements without the use of a flow control system. Figure 24 shows the demonstrated performance of an experimental pump compared with system requirements.

A series of design support tests were conducted on the moving elements of the diaphragm pump which are the spool valves, the diaphragms and the check valves. These tests provided performance and operating life information for the eventual design of a flight configuration space shuttle pump. The design support tests yielded the following results:

- . The concept has excess pumping capacity.
- . Krytox lubricated steel spool valves showed no measurable wear after seven times design life cycles.
- . Redundant check valves were satisfactory after two times design life cycles.
- . Silicone diaphragms exceeded two times design life cycles.

PAGE NO. 49

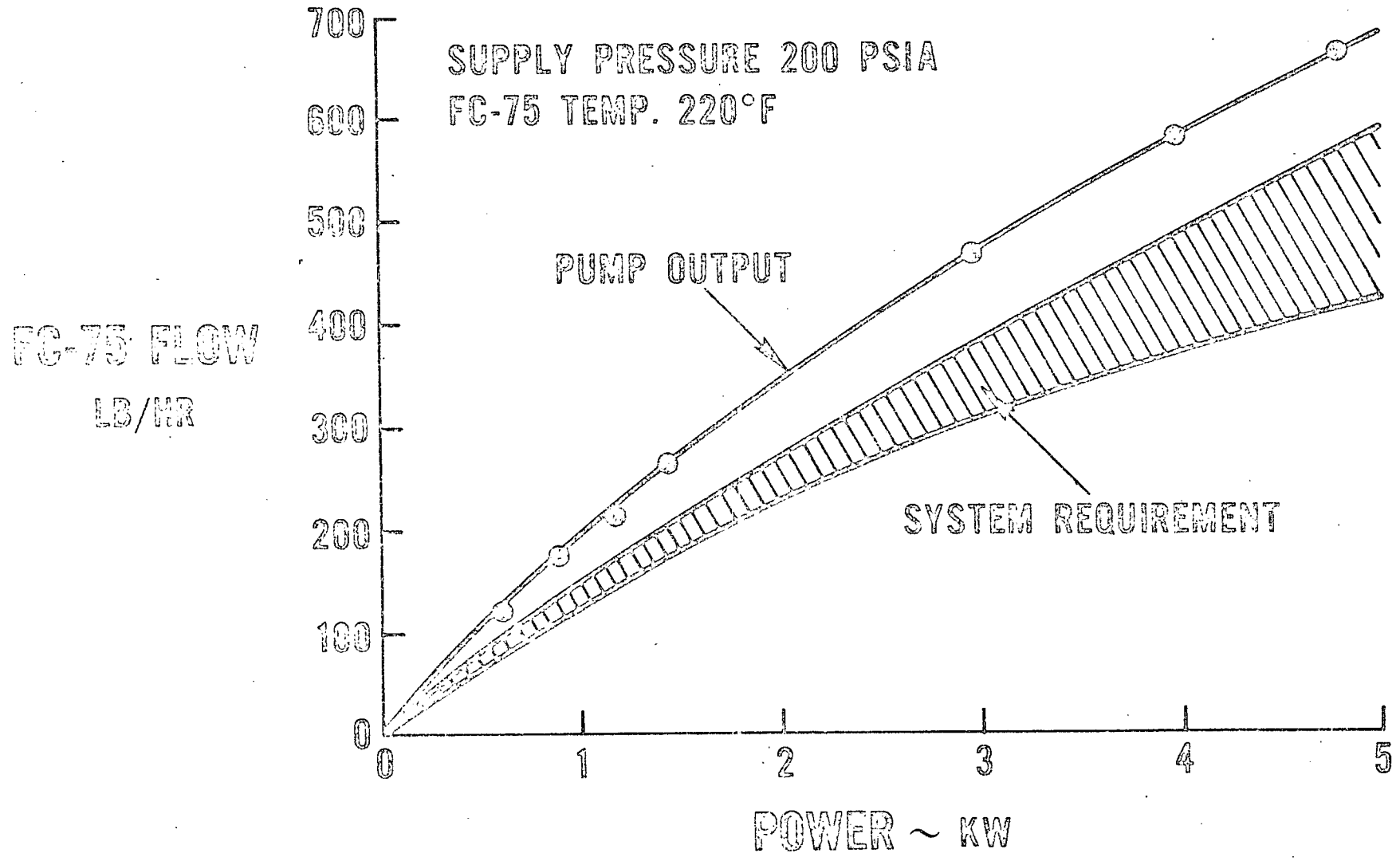

Figure 24 - Oxygen-Driven Coolant Pump Demonstrated Performance Compared with System Requirement

Viton diaphragms exceeded three times design life cycles.

It was concluded that both the Viton and Silicone elastomers are adequate materials for pump diaphragms, however, Viton is preferred because of its lower oxygen permeability. The design support testing of candidate diaphragms is presented in detail in PWA-4292, Reference: Component Test Reports, PWA-4309

A flight configuration oxygen driven coolant pump was designed based on the results of the design support testing. Figure 25 shows a cross sectional view of the EM-1 pump design.

A breadboard pump, incorporating all of the essential features of the EM-1 oxygen driven pump design, was fabricated and tested at EM-1 powerplant operating conditions. Figure 26 shows this pump installed in a test stand. The pump operated satisfactorily for 2014 hours. The test was terminated at that time because of a stand malfunction which flooded the pump gas passage with coolant. An improved design Viton diaphragm accumulated 493 hours of satisfactory operation prior to the test termination. Details of this testing are presented in PWA-4295, Reference: Component Test Reports PWA-4309.

It is concluded that the basic pump design and concept is satisfactory for Space Shuttle fuel cell applications. It is recommended that follow-on activity include pump testing through 5000 hours to confirm the basic design. Operation of the pump in a fuel cell system is also recommended.

7.3 Hydrogen Jet Pump

Product water resulting from the fuel cell reaction in the EM-1 or DM-1 powerplants is removed by the recirculating hydrogen stream. A hydrogen jet pump was considered to perform the recirculation function in the gas driven circulator fuel cell configuration. The objective of the task was to design and evaluate a hydrogen jet pump with sufficient recirculation capacity over the full power range of the EM-1 powerplant.

7.3.1 Hydrogen Jet Pump Design Support Testing - Design analysis and system studies indicated that a two stage jet pump would be required to provide the necessary recirculation flow over the full power range of the EM-1. A series of design support tests was conducted on single ejectors and on dual ejectors in series and parallel configurations to provide design information. The performance data obtained in the test series confirmed the jet pump design system and provided information to evaluate

FIG. NO. 21

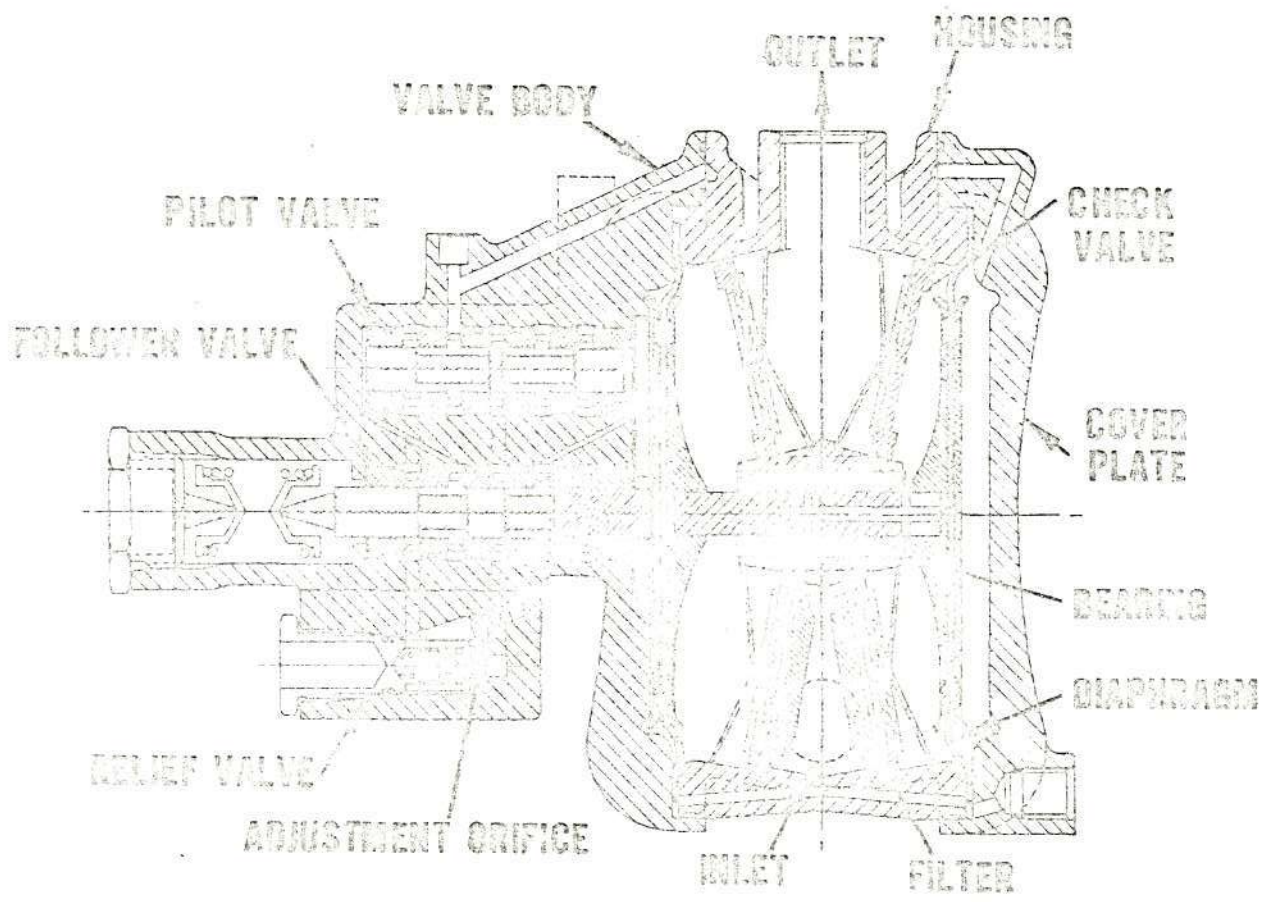

Figure 23 - EM-1 Oxygen Driven Coolant Pump



Figure 26 - Space Shuttle Endurance Pump

the effect of switching from single to dual stage. It was concluded from these tests that the dual series pump is inherently simpler than the dual parallel pump in that it does not require an internal check valve. The two pump configurations are shown in Figure 27 and 28. Details of this testing are presented in PWA-4285, Reference: Component Test Reports, PWA-4309.

7.3.2 DM-1 Hydrogen Jet Pump - A dual series hydrogen jet pump was designed and fabricated for operation on the DM-1 fuel cell powerplant. Figure 29 shows the final design configuration. The hydrogen needed for consumption enters the primary nozzle from the gas supply and provides first stage pumping of the recirculating gas. As the fuel cell electrical load is increased, the gas supply pressure will be increased by the remote sensing hydrogen regulator. When this pressure exceeds the spring force of the flow valve, the valve will open causing hydrogen to flow to the secondary nozzle thereby increasing the pumping capacity of the unit.

As the fuel cell electrical load is increased, the gas supply pressure will be increased by the remote sensing hydrogen regulator. When this pressure exceeds the spring force of the flow valve, the valve will open causing hydrogen to flow to the secondary nozzle thereby increasing the pumping capacity of the unit.

The pump was not installed on the DM-1 due to premature termination of the DM-1 test. However, a bench test was run on the pump. It was concluded from this test that the flow valve needed improvement to control properly and that the design had a low power limitation. High fuel cell electrical load pumping capacity was more than adequate. At a low fuel cell electrical load the minimum recirculation flow rate could not be maintained. Figure 30 shows a comparison of the pump capacity and the system flow requirements. It can be seen from this figure that fuel cell loads below approximately 1 kw can not be sustained by the pump.

It was concluded from this effort that the hydrogen jet pump can meet fuel cell powerplant requirements. However, additional design and development are required to improve the flow valve and increase the low electrical load pumping capacity.

7.4 Static Water Separator

In P&WA fuel cell powerplants using electrically driven circulators, the condensed water droplets in the recirculating hydrogen stream are separated from the hydrogen by a centrifugal separator which is integral with the pump and motor assembly. The gas driven circulator concept eliminates the electric drive motors. Therefore, a static water separator becomes a requirement of such a system.

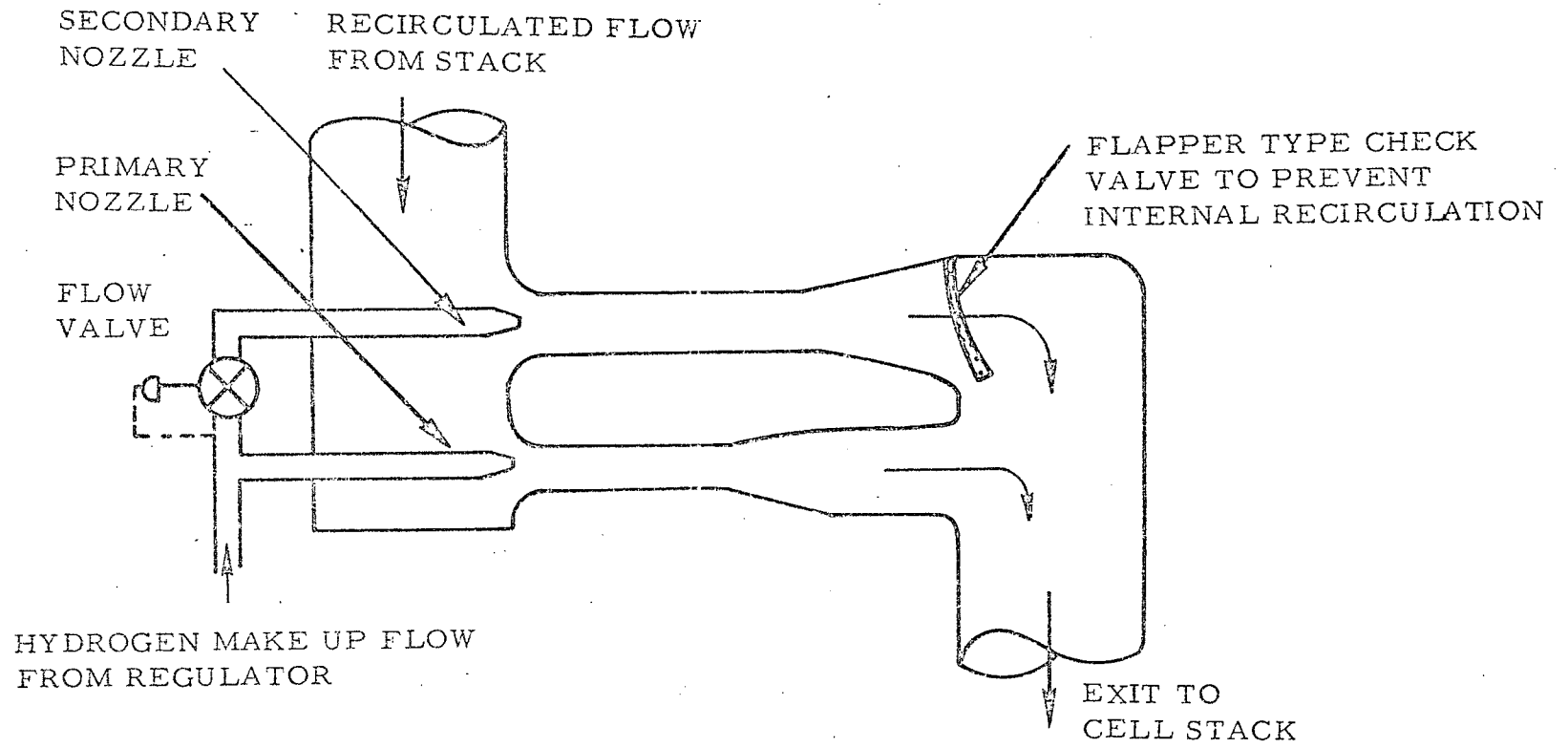

Figure 27 - Dual Jet Pump Parallel Configuration

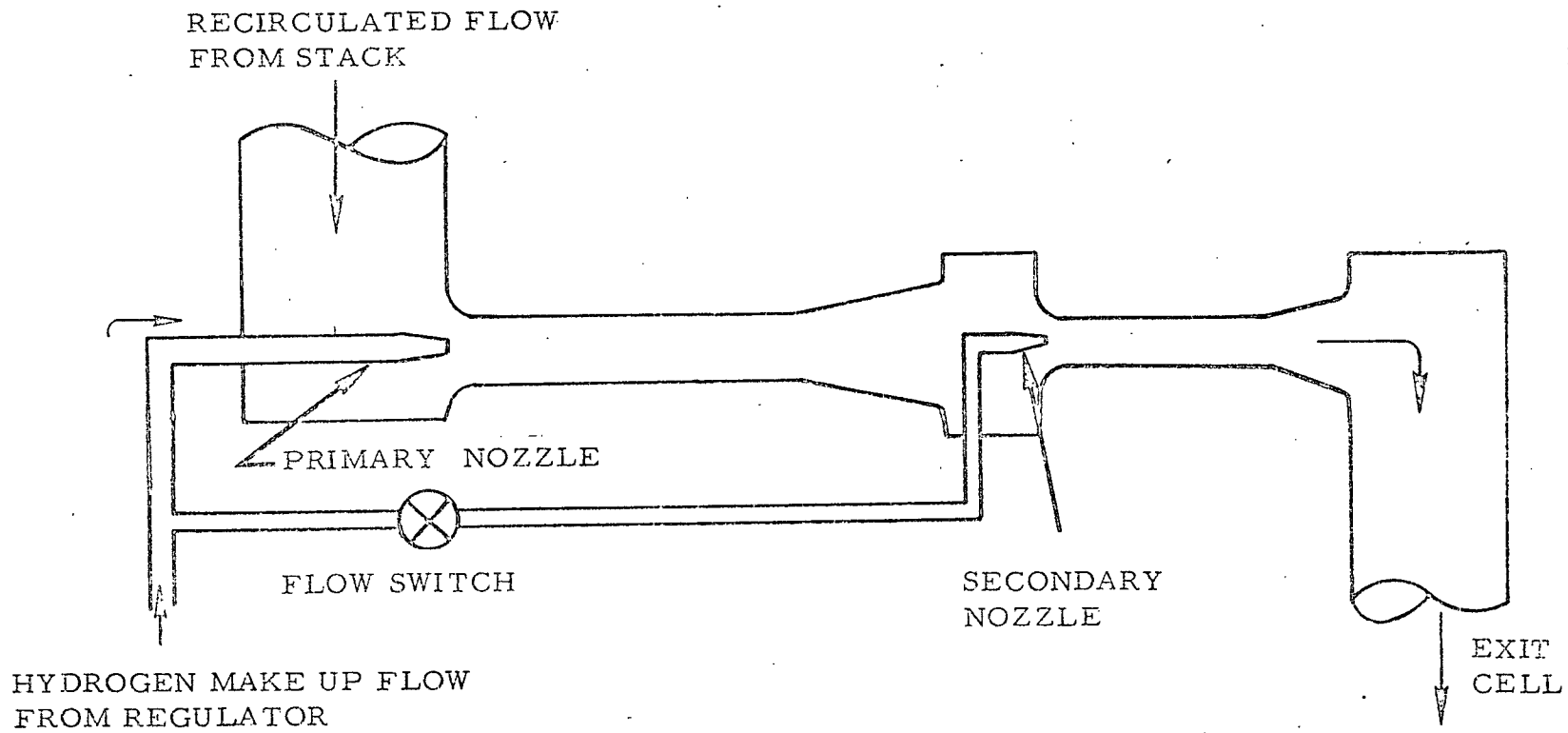

Figure 28 - Dual Jet Pump Series Configuration

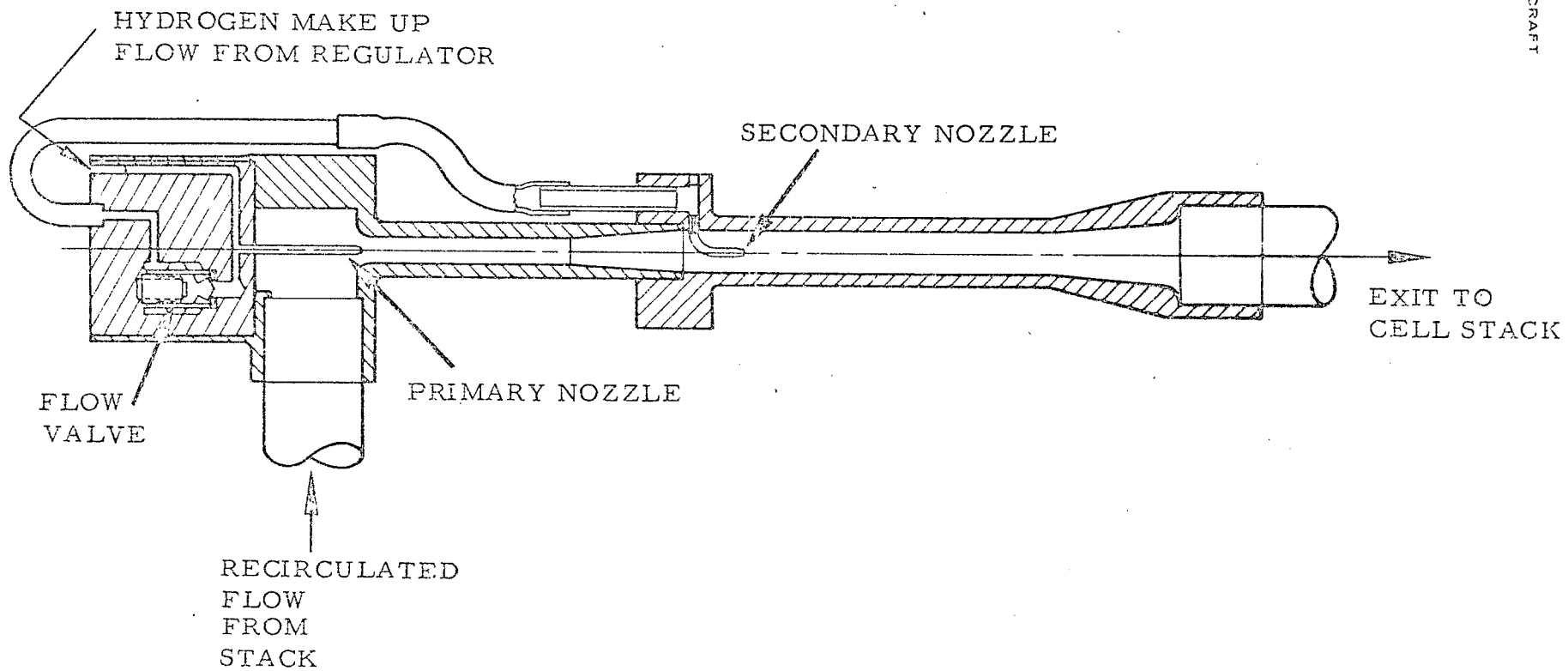

Figure 29 - DM-1 Hydrogen Jet Pump

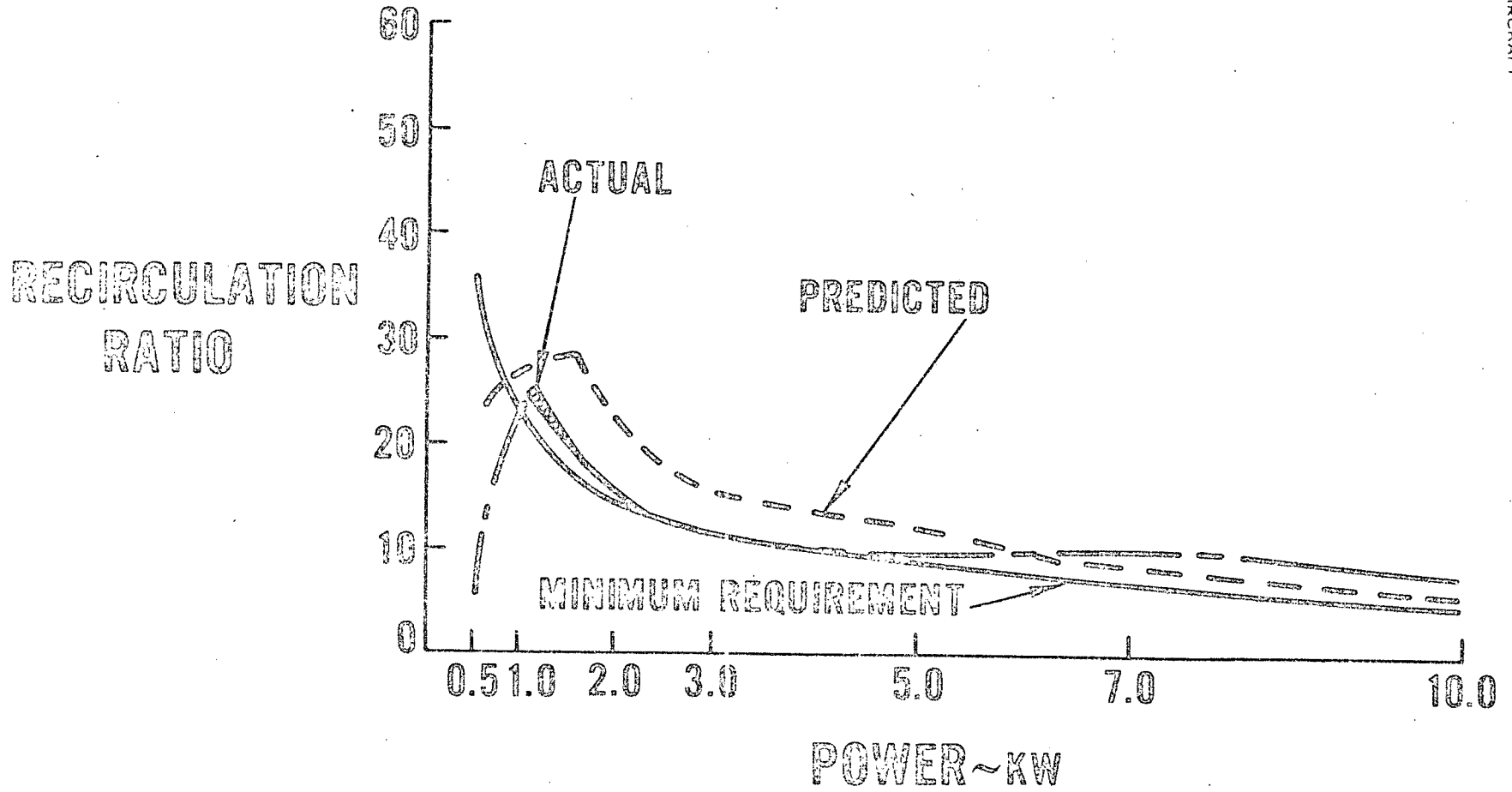

Figure 30 - DM-1 H₂ Jet Pump Performance

The configuration chosen for development is shown conceptually in Figure 31. In this arrangement, water droplets in the two phase hydrogen-water recirculating stream are removed from the stream by the wick element of the separator. The water is then transported to the separator membrane which allows water but not hydrogen to pass into a collection chamber. A regulating valve referenced to the fuel cell hydrogen stream pressure controls the discharge of product water to the spacecraft system.

7.4.1 Static Water Separator Design Support Testing - A series of design support tests was conducted to evaluate water separator configurations and separator and wick materials.

The static water separator concept requires a device which will separate liquid water from a flowing saturated hydrogen gas stream with very little pressure loss through the separator and with no loss of hydrogen gas from the flowing stream. Several static water separator configurations were defined for evaluation during the test program. Concurrent with this effort, materials investigations were conducted for possible wicking materials suitable for transporting liquid water, and/or separator materials suitable for passing liquid water flow while retaining a high resistance to gas blow through.

These tests were conducted as a two part program. One part concentrated on evaluation of wicking and separator materials. The second part was designed to evaluate various static water separator configurations using the best available wick and separator materials. The tests developed for evaluating wicking material consisted of; a wick test, a wettability test, a strength test, KOH electrolyte compatibility test and a structural integrity test. The tests developed for evaluating separator materials consisted of; a bubble pressure test, a water transport rate test, a wettability test, a KOH electrolyte compatibility test and a strength test.

The goal of the materials tests was to find a wettable, structurally sound, homogeneous, chemically inert material which could be easily configured for use in a static water separator. Initially, tests were based on using two separate materials for the wick and separator respectively, however, it was shown that from a structural stability and fabricability standpoint, a combination wick-separator in a one piece configuration was best. Although a number of materials were found which could be used for wicks or separators, the material with the best properties for the combination wick-separator approach was found to be fritted glass.

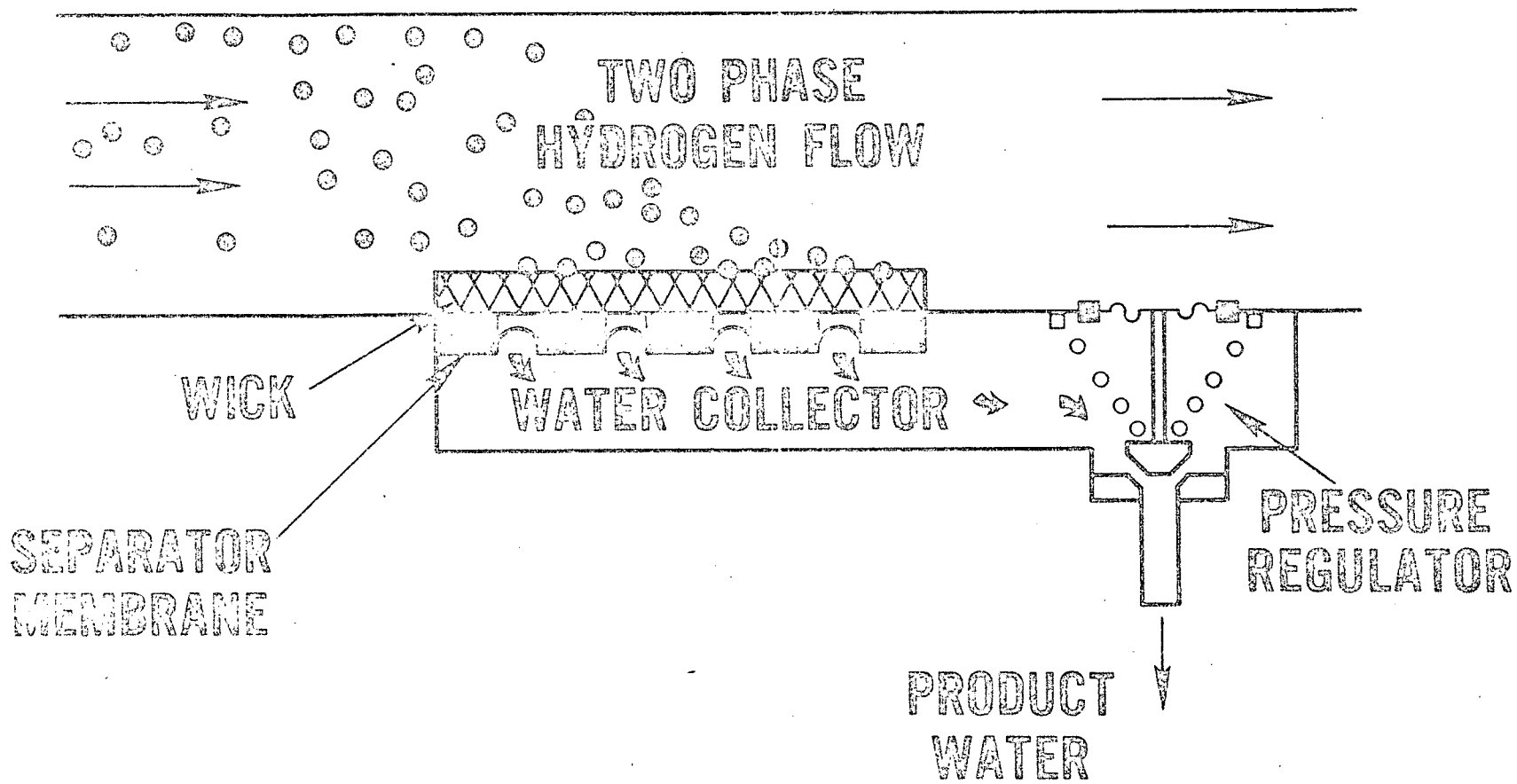

PAGE NO. 59

Figure 31 - Static Water Separator

Three basic separator configurations were tested. They were a flat plate separator, a spiral separator and a labyrinth separator. The three configurations are shown schematically in Figure 32. Several builds of each configuration were evaluated for separation capacity, pressure loss and fabricability. The labyrinth configuration was found to be the best design combination on a separation capacity and low pressure drop basis.

Details of this testing are presented in PWA-4272, Reference: Component Test Reports, PWA-4309.

7.4.2 Static Water Separator Module Test - A multi-module static water separator was constructed with fritted glass combination wicks and separators in a modified labyrinth configuration. A cross sectional representation of the unit is shown in Figure 33. The unit successfully separated water from the wet hydrogen stream, however, it was difficult to fabricate, exhibited poor flow distribution limiting its effectiveness and had a limited turndown ratio.

It was concluded from this study and testing that a static water separator using fritted glass elements in a labyrinth configuration can be used in a fuel cell powerplant. However, design and development effort is needed to improve its effectiveness and fabricability. It is recommended that follow-on activities associated with static water separation consider a porous plate condenser as an alternate approach.

7.5 Open Cycle Heat and Water Removal

Waste heat and water are produced as by-products of generating electrical power in a fuel cell powerplant. In P&WA low temperature base cells, normal removal of waste heat is accomplished by circulating a coolant fluid through the fuel cell stack. Product water is removed by circulating hydrogen through the cells and then condensing and separating the water from the hydrogen. In this system, the condenser uses the same coolant fluid that circulates through the cell stack.

In proposed Space Shuttle missions, there is the possibility that periods of time exist when the spacecraft radiator may be inoperative (during launch and re-entry) thereby making the circulating coolant ineffective. An open cycle heat and water removal mode of operation was defined by P&WA to maintain fuel cell operating parameters under these conditions. Initial work was performed on this concept under Air Force contract. The system was described previously in the conceptual design section of this report. The two main elements of the subsystem are the intercell evaporator and the humidity sensor.

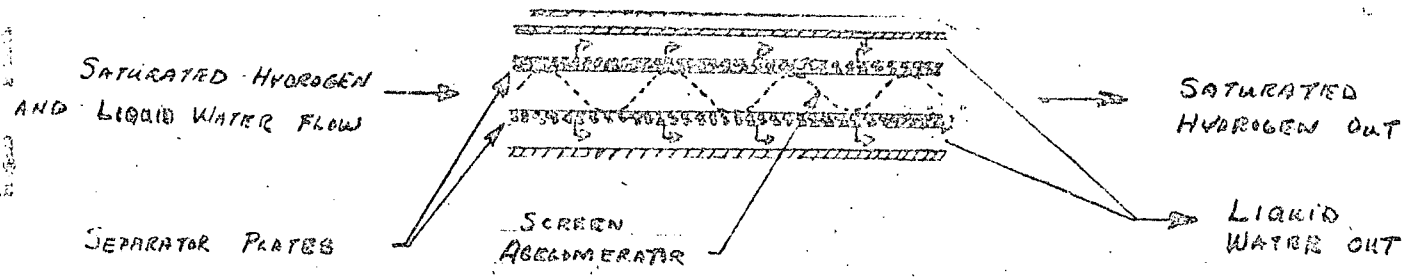

Flat Plate Separator

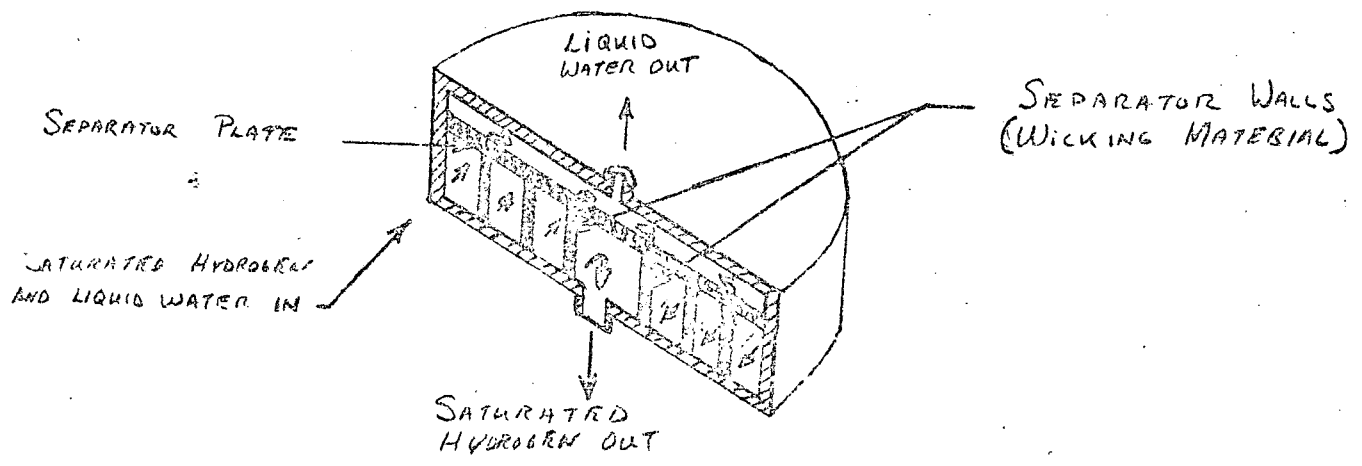

Spiral Separator

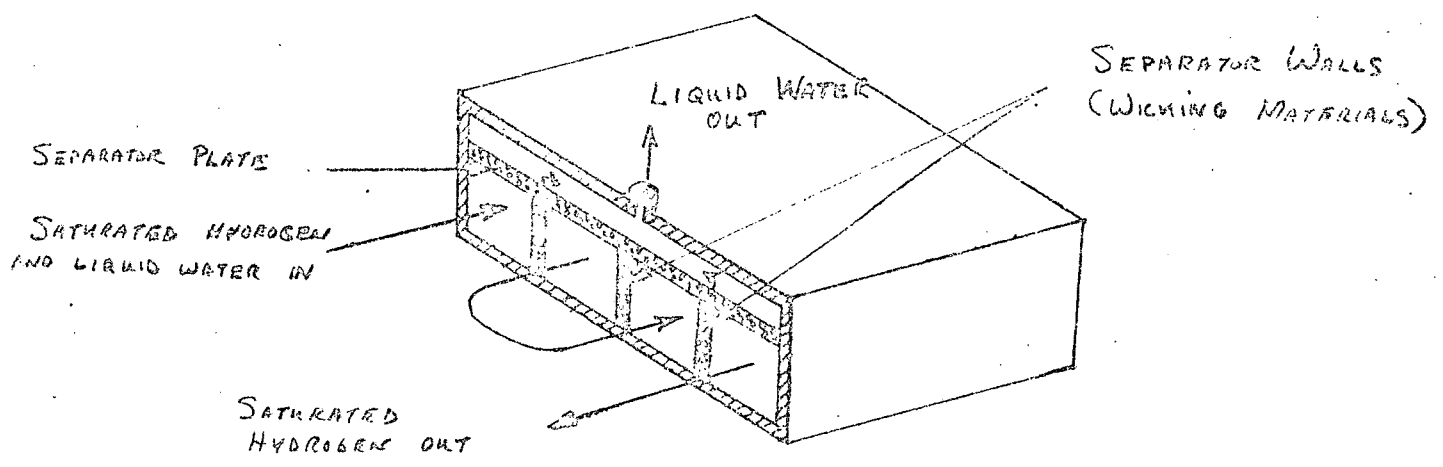

Labyrinth Separator

Figure 32 - Static Water Separator Configurations

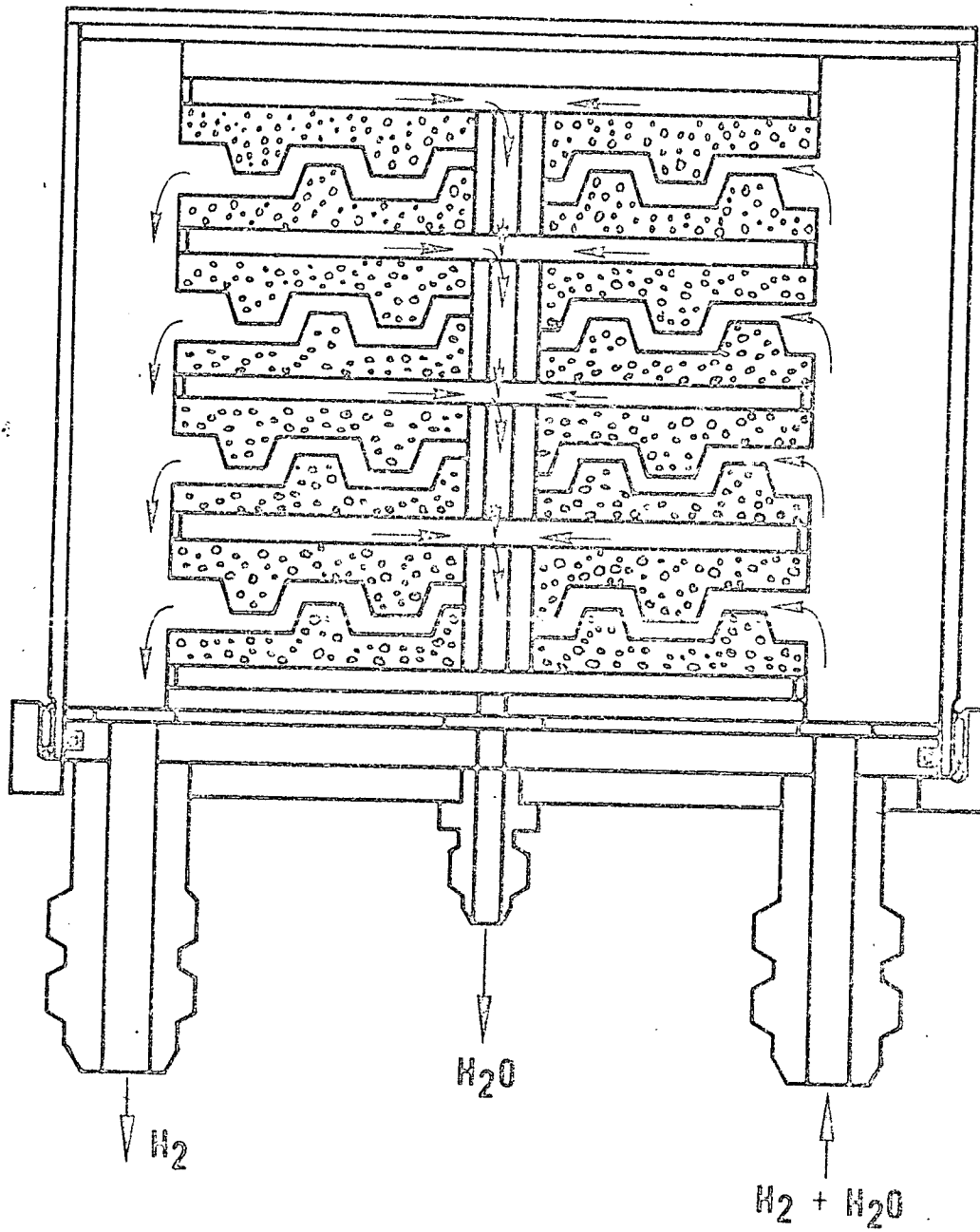

Figure 33 - Multi-module Static Water Separator

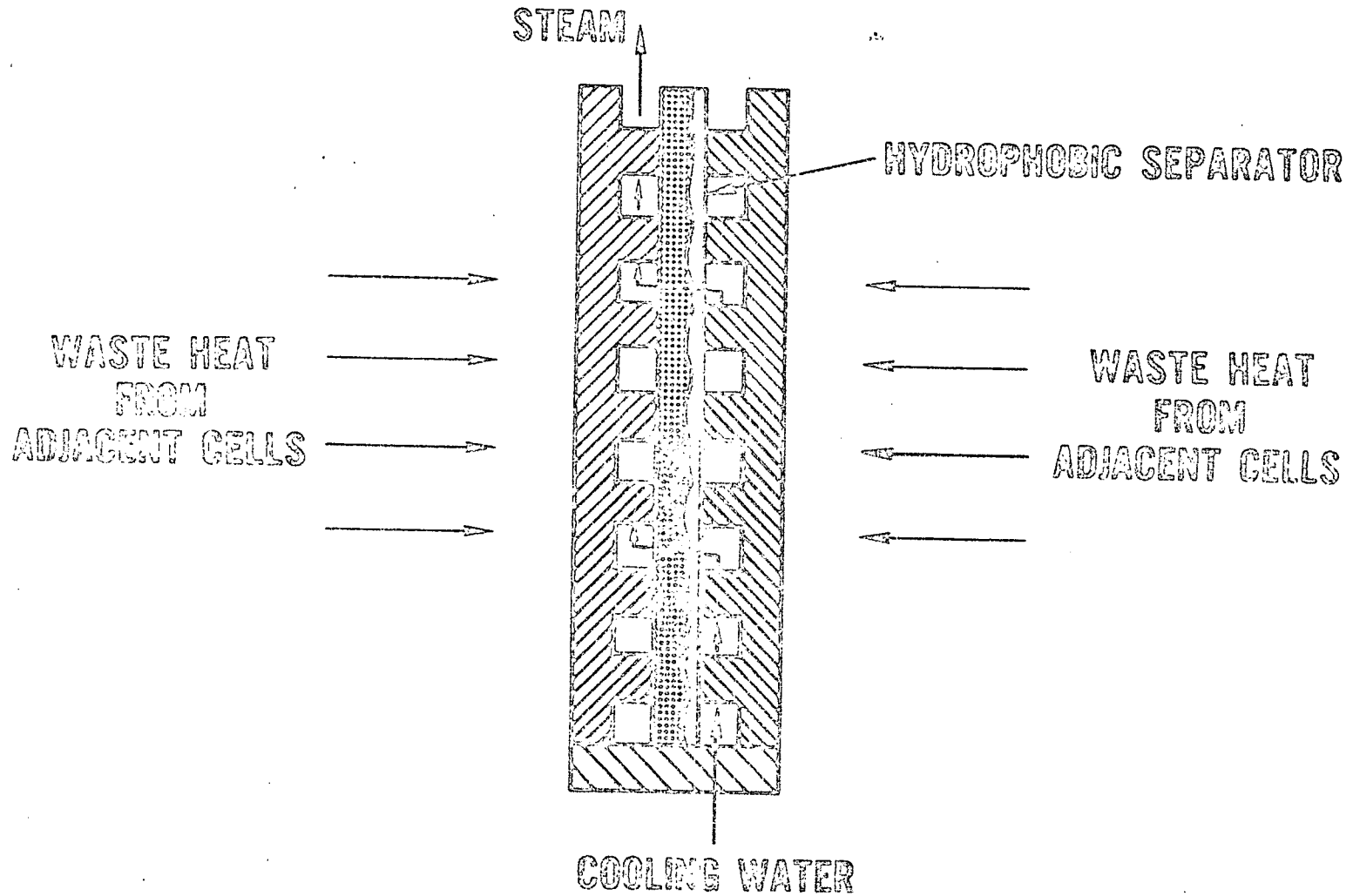

Figure 34 - Intercell Evaporative Cooling Assembly

7.5.1 Intercell Evaporator - The intercell evaporator performs the task of removing waste heat generated by the cells in the stack. A cross sectional representation is shown in Figure 34. These evaporators are assembled into a fuel cell stack between operating cells. The assemblies consist of two plates and a hydrophobic separator which is a nickel sinter treated with Teflon®. In a functional system, cooling water is admitted into the evaporator on a temperature signal. The water is converted to steam in the hydrophobic separator by the waste heat from the cells and is then vented overboard, controlled by a steam vent pressure regulator which sets the operating temperature of the cell stack.

There was no testing of intercell evaporators as separate elements in this program. The units were tested as part of a breadboard unit to be described later.

7.5.2 Humidity Sensor - The humidity sensor performs the task of controlling the venting of water vapor and hydrogen from the fuel cell to control electrolyte concentration. Proper electrolyte concentration is normally maintained in the cell stack by product water removal via the condenser and water separator. In the event that adequate cooling is not supplied to the condenser, the humidity sensor will sense an above normal moisture content of the recirculating hydrogen stream and will activate an overboard hydrogen-water vent valve.

A cross sectional representation of a condensing type humidity sensor is shown in Figure 35. The probe is installed in a fuel cell system with the ceramic wick and condensing coils in the hydrogen stream at the cell stack exit. Coolant (hydrogen or water) is circulated through the condensing coil causing water vapor from the wet hydrogen stream to condense and wet the ceramic wick. Water will re-evaporate from the tip of the wick into the hydrogen stream and in so doing will cause the imbedded thermocouple to register wet bulb temperature. An electronic controller compares the wet bulb temperature with the dry bulb temperature and activates the hydrogen/water vent valve when a preset difference between the two is exceeded.

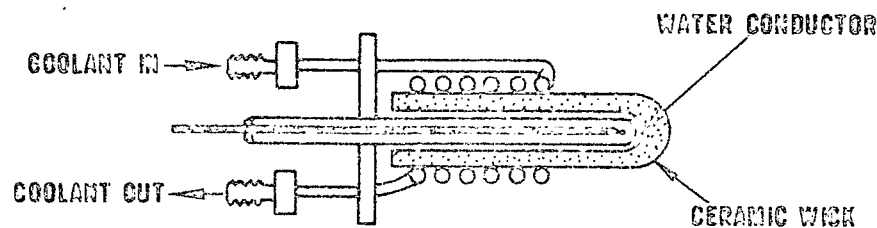

Figure 35 - Wet Bulb Humidity Sensor

A design support test program was conducted to evaluate probe materials. It was concluded that cotton fabric and pressed metal felt wicks performed adequately, but were life limited. Porous ceramic or fritted glass wicks gave equivalent performance with no detectable deterioration.

Details of this testing is presented in PWA-4266, Reference: Component Test Reports, PWA-4309.

7.5.3 Four Cell Breadboard Unit Test - A breadboard power system capable of operating in normal closed cycle mode and open cycle mode was tested to evaluate the Space Shuttle open cycle subsystem. The test unit was originally fabricated under Air Force Contract F33615-70-C-1134. It was refurbished with a new cell stack for this test program.

Figure 36 is a drawing of the power section. It included four 0.14 ft.² active area fuel cells. The intercell evaporative cooling assemblies separated the water from the steam for open cycle heat rejection. Liquid coolant flowed through cavities between the cells for closed cycle heat removal. Magnesium end plates and tie bolts provided the compression needed for the O-ring seals. The test unit included all of the functional components needed to maintain hydrogen, oxygen and coolant operating parameters in control.

The results of the testing on this unit are summarized below:

- . Completed 102 hours of which 31 hours were open cycle on two builds.
- . Demonstrated automatic open cycle heat and water removal to current densities of 1000 ASF.
- . Experienced leaching of the epoxy-glass fiber UEA frames at the water and steam manifolds.
- . Experienced severe corrosion of the magnesium evaporator frames in one build.
- . Experienced excessive creep of the unfilled Arylon plastic boiler frames in the second build.

It is concluded from these results that the open cycle heat and water removal concept is feasible, however the durability of the present frame and seal materials of the intercell evaporator and the cell is inadequate. Any follow-on activity on this subsystem should emphasize material improvement.

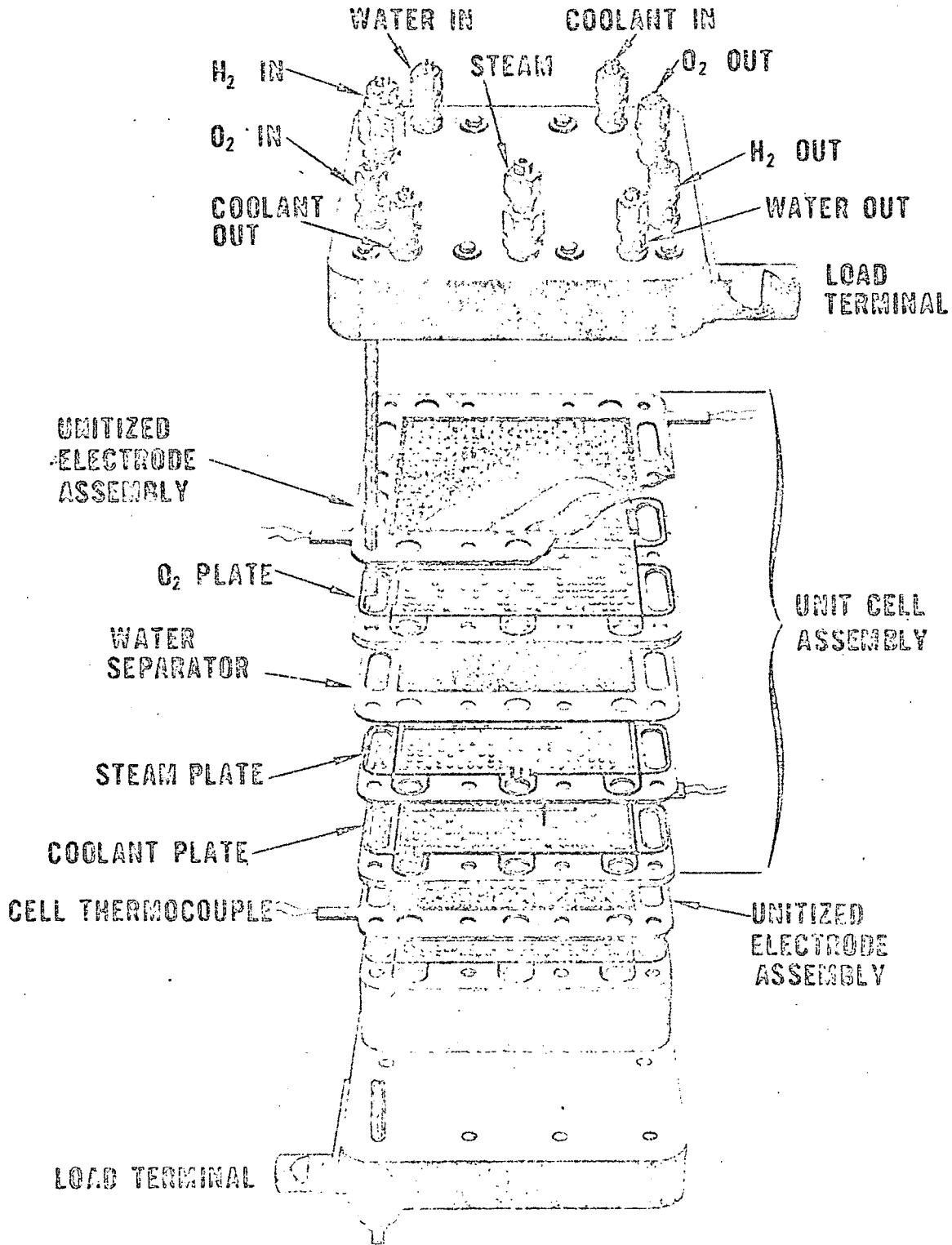

Figure 36 - Four Cell Breadboard Unit Cell Stack

8.0 REACTANT PURIFIERS

NASA studies indicated that logistic and hardware advantages would result from using propellant grade gas in the spacecraft fuel cells. Propellant grade oxygen specifications allow a hydrocarbon content of 50 ppm. If these quantities are experienced, it may be necessary to remove this contaminant from the oxygen used as a fuel cell reactant. This can be accomplished by converting the hydrocarbon to carbon dioxide and then scrubbing the carbon dioxide from the gas. This program was to evaluate existing carbon dioxide scrubber technology on a multi-cell stack operating life test and the DM-1 test, and to develop design information for a hydrocarbon oxidizer catalyst.

Carbon dioxide scrubbers were designed, built and utilized on the 6-cell operating life test and the DM-1 test. The scrubbers removed cell carbon dioxide down to 1/2 PPM throughout the testing.

A design support test program was conducted to evaluate several oxidation catalysts and determine the optimum operating conditions necessary to remove trace hydrocarbons from oxygen.

Selected catalysts were tested using oxygen containing approximately 55 ppm of methane to obtain design information for converting the hydrocarbon to carbon dioxide. The catalysts tested were:

- . 0.5% Rhodium on alumina
- . 0.5% Palladium on alumina
- . 0.5% Platinum on alumina
- . 10.0% Platinum on alumina

The activities of these catalysts in converting the methane in oxygen were determined at various levels within the temperature range of 200°F to 800°F and the pressure range of 0 psig to 60 psig.

The Rhodium catalyst was the most active in removing methane from oxygen at each temperature level and exhibited activity and decay characteristics adequate to remove hydrocarbons from oxygen at 600°F and 60 psia. The other catalysts either had lower activity or decayed more rapidly. Increasing the pressure further increased the catalyst activity.

Details of this testing are presented in PWA-4294, Reference: Component Test Reports PWA-4309.

It is concluded that this design approach is feasible for a Space Shuttle design in the event propellant grade gases are eventually selected for use by the fuel cells. Further design and development work is needed to optimize catalyst volume requirements and to define the heat source for the reactor.

9.0 CONTRACTOR LIAISON

Early in the program, Phase B Space Shuttle study contractor coordination meetings were held. Pratt & Whitney Aircraft outlined technical approaches to the Space Shuttle fuel cell powerplant and requested information on interface parameters such as voltage level and reactant supply pressure.

Trade-off studies of voltage level and high or low reactant supply pressures were conducted in response to questions. Preliminary system weight studies appeared to favor a powerplant with two stacks containing 0.5 ft² area electrodes as the best compromise between specific weight, and specific reactant consumption and voltage regulation. A review of short time (less than one second), high load transient response based on previous PC8B experience was initiated. A test program based on this experience was written to more fully define these characteristics as an aid for Phase B contractors in establishing their fault clearing procedures.

The second set of Phase B Space Shuttle study contractor coordination meetings were held at MSC on September 2, 1970 and on September 3, 1970. As a result of these meetings, P&WA prepared information for presentation at the next set of meetings to be held October 12, 1970. Subjects included inflight shutdown and restart steady-state and transient electrical output characteristics, steady-state parasite power requirements, effect of output voltage level on powerplant characteristics, heat rejection, monitoring and control, and reliability. Agreement on output voltage was needed to determine the cell area for design and testing.

Meetings were held at the P&WA South Windsor Engineering Facility on October 12, 1970. P&WA presented material on inflight shutdown and restart, steady-state and transient electrical output characteristics, steady-state and transient parasite power requirements, effect of output voltage level on powerplant characteristics, heat rejection, monitoring and control and reliability.

Coordination meetings were held on November 4 and 5, 1970 at which P&WA presented material on:

- . Checkout
- . Essential instrumentation
- . Voltage during load changes
- . Effect of voltage level on powerplant reliability and program cost
- . Effects of reactant supply pressure on powerplant characteristics
- . Effect of reactant purity on purge requirements .
- . Effects of rated power level
- . Effect of peak power level on specific weight of a dual mode fuel cell

P&WA provided each of the Phase B contractors with a PC8B Operations Manual as an example of powerplant operating and handling procedures.

Informal Space Shuttle contractor coordination meetings were held on December 2, 1970 and on December 3, 1970. The contractors were briefed on P&WA fuel cell technology program status and answers were provided for questions. P&WA presented the results of a study which showed that dual mode fuel cell systems have significant advantages over hybrid fuel cell/APU systems for the Orbiter.

Phase B Space Shuttle study contractor coordination meetings were held at NASA/MSO on March 17-19, 1971. The contractors updated their requirements for power, voltage level, voltage regulation, reactant supply pressure, and other interface conditions. P&WA raised the question of fault-clearing current capability needed from the fuel cell. The contractors provided some estimates of minimum distribution system impedance, and it was agreed some form of current limiting would be desirable.

Phase B Space Shuttle study contractor liaison meetings were held on 2 June 1971 and 3 June 1971. Pratt & Whitney Aircraft presented the characteristics of a number of potential powerplant designs for consideration by the Phase B contractors. P&WA reviewed the status of testing under the NASA fuel cell technology contract. The Phase B contractors presented miscellaneous pieces of information relating to the interaction of the fuel cell and vehicle.

An informal meeting was held on 17 June 1971 to review recent P&WA program accomplishments and to answer questions on the Space Shuttle powerplant design.

Phase B Shuttle study contractor liaison meetings were held at the South Windsor Engineering Facility on June 8 and 8, 1971. The Phase B contractors reviewed their baseline power system configurations. P&WA presented a suggested electrical schematic for Phase B contractors comments. P&WA discussed the status of the fuel cell technology program. A presentation was given and a tour conducted on the DM-1 monitoring and control data system in use at P&WA. P&WA also presented the results of a study of program cost vs. powerplant life.

Phase B Shuttle study contractor liaison meetings were held at NASA-MSFC on September 21 and 22, 1971. The Phase B contractors reviewed the status of their present configuration and indicated recent NASA directed study revisions. P&WA discussed the status of the fuel cell technology program.

10.0 COMPLEMENTARY ENGINEERING

10.1 RELIABILITY

The reliability program consisted of reliability analyses and trade-off studies conducted during the conceptual design and testing phases of the DM-1 program. Results of these analyses and trade-off studies were used to direct design efforts toward minimizing the probability of a powerplant failure. The analyses also provided criteria for follow-on program reliability and test planning tasks.

Both powerplant and component Failure Mode and Effect Analyses (FMEA) were prepared to a level of detail consistent with the existing design definition at each particular phase of the program. Special stress was placed on early input to the design concept from the FMEA. The powerplant FMEA was a general study which considered the effects of various failure modes on the powerplant to provide an overview of the conceptual design.

The detailed component level FMEA's were performed on the (a) reactor stack, (b) hydrogen jet pump, (c) oxygen-driven coolant pump, (d) coupled regulator, and (e) humidity sensor probe. The purpose of these FMEA's was to evaluate the effect of individual part failure modes on the component and on the total fuel cell powerplant. Information from these components FMEA's served as one source for the derivation of design criteria incorporated in the component design specifications.

Component level FMEA's were also performed on less well defined components and on all the remaining ancillary components in the DM-1. Information from these FMEA's will serve as a basis for more detailed analysis in subsequent follow-on programs.

Reliability trade-off studies were conducted to provide data for designing a fuel cell powerplant. Consideration was given to mission reliability, redundancy, maintainability, operating life and failure effect. These studies included investigations of powerplants with various voltage levels, powerplants with either a gas-driven or an electric-driven circulating pump, and diaphragm redundance studies for the oxygen-driven coolant pump.

Additional reliability studies included reviews of the test facilities used for the endurance testing of multicell Rig 37861 and the DM-1 powerplant and were conducted to minimize the probability of a fuel cell stack failure caused by an external (facility) source.

Details of the above were presented in the Final Reliability Summary and Analysis Report, PWA-4359.

10.2 SAFETY

During the execution of this program, the groundwork was set for achieving the safety goal of not contributing to a vehicle failure and not endangering personnel during handling and support. The main contributions to this goal were:

- . Establishment of a line of communication for the reporting and dissemination of system safety information.
- . Identification of potential hazards within early designs.
- . Gathering and dissemination of pertinent safety information required for further analyses.
- . The identification of safety action items for resolution in subsequent follow-on programs.

The system safety program consisted of safety analysis and safety documentation activities conducted during the conceptual design and testing phases of the DM-1 program. These activities were directed toward achieving the fuel cell system goal of not contributing to a vehicle failure and not endangering personnel during handling and support.

The system safety analyses conducted during the program included Gross Hazard Analysis (GHA) and Failure Mode and Effect Analysis (FMEA). The GHA was conducted early in the design phase and utilized preliminary design and operating information to provide an evaluation of the DM-1 safety design adequacy. This qualitative analysis defined gross potential hazards and determined if safety features had been incorporated into the design to eliminate these hazards. The FMEA's were performed at the system and component levels for use in both reliability and safety analyses (see Final Reliability Summary and Analysis Report, PWA-4359). Within the context of the safety program, the FMEA's established the effect of each component failure mode on system safety. Design or procedural methods to reduce the probability of occurrence of safety critical failure modes were recommended to the Program Manager. The total fuel cell system was reviewed periodically by the Systems Effectiveness Engineer to follow-up the recommendations and insure that suggested changes were incorporated.

Various material investigations were conducted during the program to determine the impact on system safety. These investigations included investigations of specific material properties dictated by the GHA and FMEA, a compilation of various properties of the non-metallics under consideration for use in a Space Shuttle powerplant and radiation tolerances for specific non-metallic materials.

Details of the above were presented in the Safety Analysis Report, PWA-4299.

10.3 QUALITY ASSURANCE

A description of the Quality Assurance activities required for the Fuel Cell Technology Program was initially prepared. The time phasing of this effort was also included.

Quality Engineering reviewed layouts and drawings during the design phase and prepared Quality Assurance data sheets. This internal document assured the inspectability of the design and delineated the required non-destructive test inspections to provide proper Quality Control.

Two meetings were held with the local NAVPRO to discuss the implementation of the contractual quality requirements in the context of a technology advancement program. NASA/MSO Quality Assurance representation was included at the second meeting. A review of the status of the fuel cell program was conducted. The extent of Quality Assurance input during this phase and that to be expected if a follow-on program were received was discussed. A firm understanding was reached concerning the quality objectives for this phase and the means by which these requirements would be accomplished. Monthly meetings were held between NAVPRO and P&WA to discuss outstanding questions.

Quality Assurance Engineering reviewed the layout for the oxygen driven coolant pump. This review determined the information required to control the quality requirements for flight parts. These special inspection and quality assurance requirements were listed on controlled Quality Assurance Data (QAD) sheets for the details within the pump assembly.

The quality assurance functions required to achieve the objectives of the DM-1 test were implemented during the test. Those areas involving quality control included material and process control, measuring and test equipment control, and the inspection of parts designated by Engineering.