

REVIEW OF DYNA-SOAR REENTRY-VEHICLE-CONFIGURATION STUDIES

By John F. Milton
Boeing Airplane Company

SUMMARY

L
1
1
0
8

All known types of reentry vehicles were investigated to determine the structural and aerodynamic characteristics of each when designed to conform to standardized design criteria and ground rules. Preliminary analyses were performed on twenty-one shapes which were subsequently reduced to nine configurations for a more definitive evaluation. From this number a single reentry system was selected as meeting the objectives of the Dyna-Soar military test system.

INTRODUCTION

The reentry vehicles studied during the Phase Alpha program are divided into four categories. These are as follows:

- (1) The modified ballistic shapes which are characterized by L/D values below 0.5.
- (2) The lifting-body shapes which are characterized by L/D values from 0.5 to 1.5 and wing loadings from 40 to 120 lb/sq ft.
- (3) The winged gliders which are characterized by L/D values from 1.5 to 3.0 and wing loadings between 20 and 30 lb/sq ft.
- (4) Variable-geometry gliders which are characterized by intermediate L/D values and wing loadings below 15 lb/sq ft. These devices change their external configuration between boost and reentry to take advantage of low planform area during boost to reduce the booster stability and structural penalties, and high wing areas during reentry are utilized to reduce the wing loading and temperatures.

The booster-reentry vehicle Step I performance and the growth capabilities during Step IIA are presented. Reentry trajectories are discussed with potential altitude-velocity exploration corridors available

for each vehicle. The maneuver capability available during reentry, the structural concepts utilized, and summary weight statements are presented for each of the configurations.

The configurations studied with some of their pertinent characteristics are presented in table I. In this table, the companies contributing technical assistance are indicated in parentheses after each configuration. The wing loading of each of these vehicles as a function of L/D is shown in figure 1.

Low L/D vehicles utilize the entire vehicle for escape and rely on large rockets for "off the pad" emergencies. The variable-geometry and glider vehicles utilize the forward portion of the body as a separate escape capsule. The modified ballistic vehicles and the M-1 lifting body rely on parachute recovery due to the low subsonic L/D characteristics. The other configurations have suitable tangential landing capabilities.

L
1
1
0
8

Because the temperatures on the vehicle vary in severity due to differences in reentry trajectories and wing loading, the heat protection systems discussed include both ablation and reradiating systems. The M-2b lifting body, the gliders, and the variable-geometry vehicles rely primarily on radiation and passive water cooling. The high L/D glider utilizes active water cooling on the nose cap and a water-glycol system (on the pressurized compartments). The M-1 lifting body utilizes an ablation system over an aluminum load-bearing shell. The drag brake has an ablation shield at the stagnation point but relies on radiation on the extended umbrella-like structure. Weight statements are provided for each configuration.

BALLISTIC REENTRY DEVICES

Modulated Drag Brake

The modulated-drag-brake reentry device shown in figure 2 achieves variable drag by means of a foldable umbrella-like structure surrounding a payload capsule. This reentry-device configuration was developed by the Everett Division of AVCO. This configuration was not developed to meet the ground rules established in the Phase Alpha study, but rather the available designs and data were adapted to satisfy the payload and manning design criteria. This configuration enjoys advantages in weight and simplicity; however, if the design were modified to meet all the Phase Alpha criteria, these advantages would be decreased.

TABLE I

SUMMARY OF REENTRY VEHICLE CHARACTERISTICS

Configuration	(L/D) _{HYPERSONIC}	(L/D) _{SUBSONIC}	Maneuver capability ^a		Altitude corridor, ft (d)	Boost weight, lb (e)	Step I, ^f V _{BO} , fps
			Lateral (b)	Longitudinal (c)			
Drag-brake device (AVCO)	0	0	0	0	0	5,260	22,350
Modified Mercury (McDonnell)		Not presented					
M-1 lifting body (Boeing)	.5	.8	±140	1,000	60,000	7,275	21,600
M-2b lifting body (Boeing - General Electric)	1.3	3.5	±895	1,980	22,000	9,391	19,700
Low L/D glider (Chance Vought)	1.5	4.2	±1,180	3,150	51,000	8,590	19,200
Intermediate L/D glider (Boeing)	2.2	4.5	±2,150	4,500	51,000	9,719	^g 19,638
High L/D glider (Bell Aircraft)	3.0	4.0	±3,500	6,900	67,000	11,291	17,050
Inflatable-wing glider (Boeing - Goodyear)	1.7	4.5	±1,400	2,950	37,000	11,069	19,150
Folding-wing glider (Lockheed)	2.0	4.4	±1,700	8,300	27,000	8,298	19,300

^aAll maneuvers are initiated at a relative velocity of 23,000 fps.

^bLateral maneuver is in nautical miles from the orbital path.

^cLongitudinal maneuver is difference in nautical miles between maximum and minimum range.

^dMinimum altitude corridor between $C_{L,max}$ and structural limit except for drag-brake device and M-1 lifting body (see text).

^eWeight at second-stage jettison (Step IIA, one-orbit mission).

^fModified Titan booster.

^gSecond-iteration data.

During boost the drag brake is folded around the pilot and equipment compartment. The upper section of the vehicle consists of abort rockets and fairings. After a successful first-stage boost, these items are jettisoned. During orbit the drag brake remains closed and vehicle attitude is controlled by reaction jets.

The drag brake is modulated to achieve reentry at a preselected altitude, position, and velocity. At the reentry point, defined by the magnitude of the deceleration, the drag brake is locked in the fully opened position. Modulation to a deceleration of 0.1g results in a longitudinal dispersion of ± 150 miles and a lateral dispersion of ± 18 miles from the preselected landing point. Modulation to a deceleration of 1.5g will reduce the longitudinal dispersion distances to ± 18 miles. Lateral-range control is not possible during reentry.

L
1
1
0
8

The open drag brake serves in lieu of a parachute for landing. An alighting gear in the form of 24 metal bellows is inflated to limit ground impact decelerations. Impact occurs at a velocity of 55 fps.

Escape from the booster is accomplished by firing the escape rockets mounted on the nose fairing assembly. When a safe altitude is reached, the fairing and rockets are jettisoned and the drag brake is opened for descent to the ground. Escape from orbit is accomplished by fully opening the drag brake.

The drag-brake device is currently designed for one reentry trajectory. Although some altitude variation could be achieved by varying drag, the current device is designed for complete deployment of the brake during reentry.

The booster considered for the Step I nonorbital program (fig. 3) is a modified version of the standard Titan booster. The modifications required are a 13-percent increase in tank wall stiffening and the addition of 238 square feet of stabilizing fin area. This combination of reentry device and booster results in a burnout velocity of 22,350 fps and a range of 1,775 nautical miles. The Step IIA orbital booster can orbit this vehicle with a potential growth in weight of 111 percent.

The maximum design temperatures are $1,710^{\circ}$ F on the stagnation plate and $1,425^{\circ}$ F on the side of the brake. The drag brake is a foldable umbrella-like structure. The outside skin of the drag brake is composed of a flexible woven mesh of 0.0015-inch-diameter René 41 wire, 200 to the inch. A coating of glass frits, held in a silicone rubber base, is applied to the skin in order to achieve nonporosity. Twenty-four ribs, spaced at 15° intervals, support the wire-mesh skin. These ribs consist of two side-by-side trusses which are joined at the top by common chord members and separated at the bottom to form an included angle of approximately 29° . Crossmembers between the bottom chords

complete the truss assembly. The truss members are tubular and fabricated from Udimet 500 alloy. The actuator struts react the major portion of the rib loading and are essentially compression members. They also serve to position the ribs during drag modulation through their attachment to the actuator mechanism. These struts are circular in cross section with essentially a frame-stringer type of construction. The material used is Udimet 500.

L
1
1
0
8

The pressurized body structure contains a 75-cubic-foot pilot's compartment pressurized to 10 lb/sq in. and a 100-cubic-foot equipment section pressurized to 6 lb/sq in. These two compartments are integrally attached by seam welding to a main structural cone. This structural cone carries the compartment inertial loads and the reaction loads of the drag brake, the actuator, and the booster transition section. A 103-inch-diameter stagnation plate, covered with Teflon, forms the bottom of the body structure. The entire body is covered with a 2-inch layer of Thermoflex insulation. Entrance to the pilot's compartment is provided by a 20-inch-diameter hatch located on the compartment side wall. Access to the equipment compartment is provided by a 4-foot-diameter hatch located in the center of the compartment floor.

A summary weight statement for the drag-brake device is as follows for a one-orbit mission:

	Weight, lb
Reentry vehicle (boost) at launch	5,260
Reentry vehicle at second-stage jettison	4,140
Airframe	1,789
Landing gear	200
Secondary power	208
Flight controls	88
Electronics	298
Environmental control	208
Crew operations	349
Payload	1,000
Reentry vehicle (reentry)	4,123
Reentry vehicle (landing)	4,084

[REDACTED]

Modified Mercury

A modified ballistic reentry vehicle similar to the Project Mercury capsule was also considered. For proprietary reasons, it will not be presented herein.

LIFTING-BODY CONFIGURATIONS

M-1 Lifting Body

The M-1 lifting-body reentry device, shown in figure 4, is a blunted cone shape that is 8 feet long with a 12-foot base diameter and a 30° half-apex angle. This vehicle enjoys weight and cost advantages, a capability for growth to superorbital missions with minimum modifications, and a wide range of reentry trajectories. The upper surface is flattened to obtain a hypersonic lift-drag ratio of 0.5. Control is provided by reaction control jets and four low-aspect-ratio electrically actuated control flaps hinged near the cone base perimeter. Rear vision is provided the pilot through the use of a single mirror system. The conditioned equipment and payload compartment extends from the pilot's compartment to the interior structural shell. The 75-cubic-foot payload bay is located to the right of the pilot's compartment.

L
1
1
0
8

The M-1 configuration includes a parachute recovery system since the subsonic L/D of approximately 0.8 is too low for a conventional landing. Drogue parachutes are deployed at an altitude of 80,000 feet and the main parachutes, at 14,000 feet. In order to insure landing within the required 10-square-mile area, terminal guidance is required during approach to the landing site to correct for wind conditions prior to deploying the drogue parachute. Both radio and inertial guidance systems are used for terminal guidance during reentry and landing to provide continuous, accurate terminal guidance. Vehicle control during reentry and approach to the landing site may be either automatic or manual.

Maneuver capability of the M-1 device during reentry can provide a lateral-range deviation from the orbital path of 140 nautical miles when maneuver is initiated at 23,000 fps.

The normal reentry exploration corridor for the M-1 configuration is considered to lie within the trajectory for $C_{L,max}$, $\phi = 0^\circ$, and a ballistic trajectory ($C_L = 0$) which imposes limiting decelerations on the pilot (reentry angle of -2.5°). The corridor is approximately 60,000 feet in the hypersonic region and 30,000 feet in the lower supersonic region.

[REDACTED]

The booster for the Step I suborbital program is a standard Titan booster (fig. 5) modified to provide stability and to carry the loads imposed by the presence of the reentry device. An 18-percent increase in tank wall stiffening and an additional 124 square feet of fin area increase the booster weight by 1,111 pounds. This modified Titan booster is capable of attaining a burnout velocity of 21,600 fps with the M-1 reentry vehicle. A 400,000-pound-thrust Titan-Centaur booster can provide orbital velocity with a potential growth in allowable weight of 52 percent.

L
1
1
0
8

The basic structural concept for the M-1 vehicle utilizes a cool, semimonocoque aluminum pressurized structure which is protected from high external flight temperatures by a polyethylene ablation cover. The ablation-cooled structural approach is used because it is more efficient for the short reentry times and high heating rates which are typical of a low L/D reentry trajectory. The ablation material is polyethylene which ablates at 375° F and has good insulation properties. The ablation thickness is based on a structural skin design temperature of 120° F.

The M-1 structure consists of a pressurized load-carrying aluminum external shell which is reinforced with frames, bulkheads, and longerons. The frames are spaced at 8 inches and are used with the skin to withstand internal pressure loads. In addition, they provide longeron column stabilization and serve as panel shear stiffeners to the skin. Bulkheads are used to separate the various pressurized compartments. Four longerons resist fuselage bending loads and distribute booster, parachute, escape rocket, and landing loads to the external shell. The pilot's environmental compartment is an aluminum-frame structure, attached to the four longerons. Access to the pilot's compartment is provided by an inward opening hatch. Access to the equipment and payload compartments is provided by panels in the vehicle's top surface and in the aft bulkhead.

The weights of the M-1 device for a one-orbit mission are summarized as follows:

	Weight, lb
Reentry vehicle at boost burnout	7,275
Airframe	2,720
Landing gear	370
Propulsion	618
Secondary power	741
Flight controls	123
Electronics	768
Environmental control	527

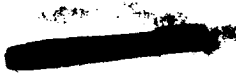

	Weight, lb
Crew operations	408
Payload	1,000
Reentry vehicle (reentry)	6,509
Reentry vehicle (landing)	5,453

M-2b Lifting Body

L
1
1
0
8

The M-2b lifting-body configuration shown in figure 6 is a blunted conical lifting-body shape consisting of a 13° half-apex cone angle and a flat upper surface. This configuration has conventional landing capabilities, a low weight relative to the glider systems, and requires less booster modification than the systems with a large planform. The afterbody surfaces are boattailed to minimize the base drag for subsonic flight and to achieve trim with a noseup angle of attack. The vehicle is sized to keep the weight as low as possible and retain the center of gravity in an appropriate location. Technical assistance in the development of this vehicle was received from the Missiles and Space Vehicle Division of the General Electric Company. Ames wind-tunnel data shows a hypersonic L/D of 1.3 and a subsonic L/D of 3.5 for the M-2b configuration. This high subsonic L/D allows the M-2b lifting body to make a conventional landing with a minimum touchdown speed of 187 knots.

Normal landing is accomplished by touchdown on aft skids using a mechanical energy-absorbing system. The forward gear consists of an air-charged oleo and dual wheels which are stored in a pressurized and cooled compartment during flight. Direct pilot vision is provided as an aid in landing and for observation during the other phases of flight. The forebody section separates for pilot escape during the various phases of the flight. The escape capsule is recovered by parachute and utilizes crushable structure on the bottom of the capsule for energy absorption. The payload compartment is located in the pressurized aft section of the vehicle. Expendables are located in the extreme rear in individual pressurized containers. This arrangement allows the pilot to separate himself from the payload, auxiliary power unit (APU), expendables, and control surfaces in the event of an emergency condition.

Maneuver capability of the M-2b device during reentry can provide a lateral-range variation of 895 nautical miles from the orbital path and a longitudinal-range variation of 1,980 nautical miles, when maneuver is initiated at 23,000 fps.

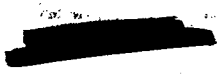

The normal reentry exploration corridor for the M-2b configuration lies between the trajectories for $C_{L,max}$, $\phi = 0^\circ$ and $(L/D)_{max}$, $\phi = 45^\circ$. The corridor is approximately 22,000 feet in the hypersonic region and 60,000 feet in the lower subsonic region.

The standard Titan booster for the Step I suborbital program (fig. 7) is modified to increase tank stiffening and add 253 square feet of fin area, with a total weight change of 2,103 pounds. This booster can attain a burnout velocity of 19,700 fps and a range of 2,440 nautical miles. A 400,000-pound-thrust Titan-Centaur booster provides orbital velocity with a potential growth in allowable weight of 14 percent.

Various structural concepts were investigated for the M-2b vehicle. A reradiation heat-protection system was considered most suitable because of the high heating rates which are experienced for long periods of time. Nose equilibrium temperatures are $3,900^\circ$ F. The bottom surface varies from $2,700^\circ$ F immediately aft of the nose cone to $2,000^\circ$ F on the lower surface behind the escape capsule. The leading edges of the fins and control surfaces reach temperatures above $2,280^\circ$ F.

A concept was investigated in which the reradiative heat-protection shield also carried the primary air loads. Coated niobium alloy was proposed as the primary structural material, because of the low oxidation rate of niobium as compared with coated molybdenum alloys. This hot load-carrying structural concept provides a lighter weight vehicle. However, the materials, processes, and fabrication techniques involved with refractory alloys will require considerable development before sufficient confidence could be established to permit its use on a manned vehicle.

The insulated and cooled structural concept which has been chosen for the M-2b vehicle consists of a hot, nonstructural outer shell, made of refractory materials, insulation, and passive water walls, which protects the inner aluminum load-carrying structure. Greater confidence exists in the structural integrity of this concept since aluminum is used for primary load-carrying structure.

A Chance Vought developed "Zirod" design is used to withstand the $3,900^\circ$ F temperature experienced on the nose of the vehicle. In the areas on the vehicle where the temperature is between $2,000^\circ$ F and $3,400^\circ$ F, combinations of zirconium oxide foam, molybdenum, fibrous alumina insulation, and a water wall are used. For areas with temperatures below $2,000^\circ$ F, René 41 sheet is used for the external surface, backed up by a René 41 corrugated sheet, MIN-E-2000 insulation, and a water wall. The thickness of the structure is sized for a maximum temperature limit of 120° F on the internal aluminum structure.

The internal load-carrying structure consists of an aluminum shell, supported by conventional aluminum frames, bulkheads, longerons, and shear beams. Pressurized compartments, formed by the load-carrying skin, bulkheads, and shear beams, are used for the pilot and the equipment. Access to these areas is provided by access doors or panels. Structural continuity for body axial and bending loads is provided by the four longerons which also distribute the boost loads. Explosive attachments are provided for separation of the escape capsule from the vehicle. Shear continuity between the escape capsule and the vehicle is provided at the separation bulkhead by the use of fore-and-aft shear pins.

Aluminum frames, attached to the load-carrying structural shell, distribute the shear loads throughout the vehicle. These frames are also designed to minimize structural deformation under the outer insulation shell.

A M-2b summary weight statement for a one-orbit mission is as follows:

	Weight, lb
Reentry vehicle at boost burnout	9,391
Airframe	3,440
Landing gear	270
Propulsion	345
Secondary power	1,049
Flight controls	230
Electronics	786
Environmental control	1,661
Crew operations	610
Payload	1,000
Reentry vehicle (reentry)	9,196
Reentry vehicle (landing)	8,169

GLIDER CONFIGURATIONS

Low L/D Glider

The low L/D glider model is shown in figure 8. The purpose of this design was to explore the relatively more compact arrangement obtainable with lower L/D shapes. This glider has an $(L/D)_{max}$ of 1.5 at Mach 20, and an $(L/D)_{max}$ of 4.25 at landing which provides

L
1
1
0
8

conventional landing capability and good research-data-gathering ability. This configuration was developed by Chance Vought Aircraft, Inc., Astronautics Division. The glider has a wing loading of 29.1 lb/sq ft at a weight of 8,590 pounds.

L
1
1
0
8

The complete glider consists of two major sections. The forward section is the escape capsule, which may be separated at any point in the flight path and return to earth as a stable unit. The capsule contains the pilot, his controls, environmental protection, and necessary survival equipment. Forward and side vision are provided the pilot to assist in observation and landing. The forward window is shielded during reentry and exposed when required for landing. The cockpit is protected from aerodynamic heating effects by a cooled and insulated structure. The capsule is aerodynamically similar to the glider and provides escape from all portions of the flight regime. The maximum temperatures during escape are no more severe than during normal reentry. A separation rocket is provided for ground-level escape from the booster. The aft portion of the glider body is a pressurized and conditioned compartment containing all glider equipment, except that which functionally must be forward or that which the pilot needs during escape.

The equipment compartment has usable volume of 490 cubic feet. This large volume provides for the 75 cubic feet of payload, the necessary subsystems, and space for a crawl-way. The equipment is arranged with the basic electronics, guidance, pressurization, and cooling equipment on the left side of the compartment and the payload, secondary-power equipment, and fuel on the right side.

Conventional unpowered landing approach capability is considered to be good because of the high subsonic L/D and low wing loading which reduce equilibrium sink rates and approach speeds.

Maneuver capability during reentry when initiated at 23,000 fps allows a lateral-range variation of 1,180 nautical miles from the orbital path and a longitudinal-range variation of 3,150 nautical miles.

The minimum normal exploration corridor between the trajectories for $C_{L,max}$ and the lower flight limit is 51,000 feet at 21,000 fps. This lower limit, determined by structural temperature limits, is 6,000 feet below the trajectory for $(L/D)_{max}$ with $\phi = 45^\circ$.

The Titan booster (fig. 9), modified to include 1,700 pounds for tank stiffening and 2,520 pounds for stabilizing fins, will provide the reentry device with a burnout velocity of 19,200 fps and a range of 2,500 nautical miles during the suborbital program. Orbital velocity can be obtained with a 400,000-pound-thrust Titan-Centaur booster. The potential growth capability with this booster is 8 percent of glider launch weight.



Structurally, the glider has a pressurized body with a water-cooled basic structure, and radiation-cooled wing, wing leading edge, and nose cap. The basic body is an ellipsoidal-shaped semimonocoque structure of 15-7 stainless-steel alloy. Open-faced honeycomb forms a retainer for the water-wick heat sink. An 0.008-gage, 15-7 stainless-steel vapor barrier separates the water wall and insulation.

Fiberfrax insulation is used for all applications up to 2,000° F and fibrous alumina, where temperatures exceed 2,000° F. An exterior shield is attached to the pressure wall by segmented channel frames. This shield is a 0.012-gage, 0.5-percent titanium-molybdenum in areas where the temperature exceeds 2,000° F and a 0.012-gage, René 41 nickel-base alloy in all other areas.

The nose cap is made up of zirconium oxide rods retained by a siliconized graphite spherical shell. This cap is attached to a 0.5-percent titanium-molybdenum skirt. Siliconized graphite tiles are applied to the exterior surfaces where the temperature exceeds 2,700° F.

The wing structure consists of a radiation-cooled truss structure with a covering of light-gage skin. Upper skins are 0.012-gage, René 41 with channel stiffeners spotwelded to the skin. The lower skins are built up of a 0.012-gage, 0.5-percent titanium-molybdenum outer shield with Fiberfrax or fibrous alumina insulation and René 41 corrugations.

Wing leading edges are 0.05-gage, 0.5-percent titanium-molybdenum alloy with fusion-welded ribs. The leading edges are segmented and supported from a René 41 beam. Fibrous alumina insulation protects the beam from the hot leading-edge surface.

A summary weight statement for the low L/D glider for a one-orbit mission is as follows:

	Weight, lb
Reentry vehicle at boost burnout	8,590
Airframe	3,255
Landing gear	270
Propulsion	230
Secondary power	1,062
Flight controls	332
Electronics	786
Environmental control	1,125
Crew operations	530
Payload	1,000
Reentry vehicle (reentry)	8,346
Reentry vehicle (landing)	8,023



L
1
1
0
8

Intermediate L/D Glider

The intermediate L/D glider is shown in figure 10. This glider has been configured with the objective of developing a design with a hypersonic L/D around 2 and a wing loading commensurate with reentry temperature limits. The configuration shown has a hypersonic L/D of 2.2 and a subsonic L/D of 4.5 with a wing loading of 28.7 lb/sq ft. This reentry device offers the advantages of moderate design temperatures and booster modifications, conventional landing capability, and a very good research potential.

L
1
1
0
8

The complete glider consists of two major sections. The forward section, which serves as the escape capsule, includes the pilot's compartment and all his emergency equipment. This section may be separated from the aft portion of the glider at any point in the flight path and returned to earth as a stable unit. The aft section of the glider contains all equipment except that required in the forward portion (escape capsule) for functional or emergency reasons.

The lateral-range control of the intermediate L/D glider, starting from a relative velocity of 23,000 fps, is 2,150 nautical miles. From the orbital flight path the minimum longitudinal range occurs at $C_{L,max}$ and is 3,100 nautical miles. The maximum longitudinal range at $(L/D)_{max}$ is 7,600 nautical miles.

Due to slightly lower landing approach speed and a higher L/D during landing approach the intermediate glider should be superior to the X-15 research airplane in landing capability. Landing runout distances are acceptable since the nominal touchdown speed is 150 knots.

The flight envelope for the intermediate L/D glider is limited by structural capabilities which are established by the temperature capability of the structure. The normal exploration corridor between $C_{L,max}$ and the minimum flight limit has a minimum value of 51,000 feet at a velocity of 21,500 fps.

The Titan booster for the suborbital program (fig. 11) will require modification to accommodate the intermediate glider. This modification includes the addition of 613 square feet of stabilizing fins and stiffening of the tank structure with a total added weight of 4,469 pounds. This modified booster will provide the intermediate glider with a relative burnout velocity of 19,638 fps and a longitudinal range of 4,500 nautical miles. Preliminary studies of the Titan-Centaur booster for the orbital program indicated the need for an 8-percent weight reduction on the glider; however, improvements in transition weights and the

use of storable propellants in the Titan stage will allow the attainment of orbital velocities with a potential growth in glider weight of 5 percent.

The glider structure utilizes Rene 41 radiation-cooled determinate trusswork with a covering of thin-gage corrugation-stiffened skins.

Controlled-environment compartments are provided for the pilot, glider equipment, and payload. These compartments are supported from the basic trusswork in a manner designed to minimize thermally induced stresses.

The pilot's compartment is constructed of 15-7 stainless-steel alloy, brazed honeycomb with a water-wall passive heat sink. This compartment is fusion-welded at all joints except the entry hatch and windows.

The equipment and payload container is a large cylindrical "can" supported between the two main fore-and-aft trusses. It is constructed of 2014 aluminum and insulated with Refrasil or comparable silica fiber insulation. A thin-foil Hastelloy "X" cover is added on the exterior of the insulation for containment and radiation shielding.

The nose cap is a Chance Vought developed "Zirod" design using zirconium oxide rods retained in a graphite spherical shell. This cap is attached to an insulated René 41 truss structure. Skins on the lower surface and sides just aft of the cap are insulated panels of 0.5-percent titanium-molybdenum shield and René 41 or HS-25 corrugations.

The leading edge is constructed of 0.5-percent titanium-molybdenum segments supported from a René 41 corrugated web support beam. This beam attaches to the wing spar trusses and is discontinuous at the joints to prevent interaction due to differential thermal expansion.

The skin panels on the lower surface are subjected to temperatures in excess of 2,000° F. These panels are constructed of an outer shield of 0.5-percent titanium-molybdenum, fibrous alumina insulation, a Hastelloy "X" screen retainer, and René 41 load-carrying corrugations.

A summary weight statement for the intermediate L/D glider for a one-orbit mission is as follows:

	Weight, lb
Reentry vehicle at boost burnout	9,719
Airframe	4,321
Landing gear	270
Propulsion	230

L
1
1
0
8

	Weight, lb
Secondary power	1,104
Flight controls	293
Electronics	786
Environmental control	1,185
Crew operations	530
Payload	1,000
Reentry vehicle (reentry)	9,455
Reentry vehicle (landing)	9,063

L
1
1
0
8

High L/D Glider

The basic design objective for the glider shown in figure 12 was to provide a high hypersonic L/D design with a wing loading sufficiently low to maintain acceptable reentry temperatures. The $(L/D)_{max}$ is 3.0 at Mach 20 and is 4.0 at landing speed. The glider has a wing loading of 26.1 lb/sq ft at a reentry weight of 10,570 pounds. This configuration was developed by the Bell Aircraft Corporation. This configuration has the advantages of relatively lower temperature, excellent lateral-maneuver capability, and excellent potential for gathering research data.

The complete glider consists of two major sections. The forward section is the escape capsule, which may be separated at any point in the flight path and can be returned to earth as a stable unit. The entire basic structure is cooled to a maximum temperature of 250° F by a system that circulates a solution of water and glycol.

The capsule contains the pilot, his controls and environmental protection, and necessary survival equipment. Side vision is provided during the entire flight. A forward window is protected by a fairing until after reentry when it is necessary for landing. It is aerodynamically similar to the glider and provides escape from all portions of the flight regime. The maximum temperatures during escape are no more severe than during normal reentry. A separation rocket is provided for ground level escape from a burning or exploding booster. The aft portion of the glider body is a pressurized and conditioned compartment containing all glider equipment except that which functionally must be forward or that which the pilot needs during escape.

Due to the high subsonic L/D and low wing loading, this reentry vehicle has very good landing characteristics with a lower sink rate and approach speed than the X-15 research airplane. This reentry vehicle

has excellent lateral maneuver capability and range control since these characteristics are primarily affected by the hypersonic L/D. This vehicle has a lateral capability of 3,500 nautical miles from the orbital path and longitudinal-range control from a minimum of 4,500 nautical miles to 11,400 nautical miles when maneuver is initiated at a relative velocity of 23,000 fps.

The normal exploration corridor for this vehicle, between the $C_{L,max}$ trajectory and the lower flight limit, which is determined by dynamic pressure and temperature limitation, has a minimum of 67,000 feet at 21,000 fps.

The standard Titan (fig. 13) for the Step I suborbital program will provide a burnout velocity of 17,050 fps and a 3,780-nautical-mile range. The modifications required include 2,120 pounds of tank stiffening and 5,090 pounds of fin (889 square feet). The 400,000-pound-thrust Titan-Centaur booster was considered for the once-around orbital mission; however, the vehicle weight would have to be decreased by 34 percent to achieve this capability with this booster.

Structurally, the glider embodies the concept of a pressurized body with the basic structure cooled by a circulated water-glycol system. The wing leading edges are radiation cooled. The glider primary load-carrying structure is conventional, semimonocoque aluminum insulated from the aerodynamic heat. The insulation is contained by outer shell panels of refractory or super alloys. These outer panels are small with gaps between panels for accommodation of differential thermal expansion. Where temperatures exceed 2,000° F, a corrugation-stiffened 0.012-gage, 0.5-percent titanium-molybdenum outer panel is used. Where temperatures are 2,000° F or less, the panel is made of brazed HS-25 honeycomb with 0.0035-gage face skins and 0.002-gage core. Between the outer shell and the aluminum primary structure is a layer of alumina powder insulation contained in foil wrappers. This foil is Inconel 702 where the outer panel is HS-25 and platinum where the outer panel is molybdenum.

The nose cone utilizes a water-spray cooling system to maintain the HS-25 machined nose cap at temperatures below 1,600° F. Steam generated as the water cools the nose cap is bled overboard at the edge of the cap. The HS-25 trusses with a covering of 0.012-gage, 0.5-percent molybdenum skin are used to attach the nose cap to the cooled aluminum fuselage.

The leading edges are heat-sustaining siliconized graphite segments supported by molybdenum channels to the cooled aluminum wing structure. A small panel of corrugation-stiffened 0.040 molybdenum is used on the lower surface just aft of the graphite segments.

The control surfaces are radiation-cooled, semimonocoque structures using Inconel corrugated skin panels and spanwise beams. The lower surface is protected by a 0.012-gage corrugation-stiffened 0.5-percent titanium-molybdenum outer skin with alumina powder insulation.

A summary weight statement for the high L/D glider for a one-orbit mission is as follows:

	Weight, lb
Reentry vehicle at boost burnout	11,291
Airframe	5,318
Landing gear	338
Propulsion	508
Secondary power	981
Flight controls	494
Electronics	751
Environmental control	1,332
Crew operations	569
Payload	1,000
Reentry vehicle (reentry)	10,570
Reentry vehicle (landing)	10,153

L
1
1
0
8

VARIABLE-GEOMETRY CONFIGURATIONS

Inflatable Reentry Device

The inflatable vehicle is a manned, variable-geometry device with orbital flight capabilities. In the launch configuration, it is a pointed, cylindrical body with a deflated planform area of less than 300 square feet; prior to reentry it is inflated and assumes a delta planform of 1,800 square feet as shown in figure 14. The relatively small size during boost permits use of an ICBM booster with very little modifications. The large inflated wing area makes possible reentry at high altitudes where vehicle surface temperatures and heating rates are minimized.

The basic arrangement of the inflatable vehicle reentry configuration consists of a rigid metal crew compartment/escape capsule at the forward end, a rigid payload and equipment pod housed within the wing as far aft as possible, and an inflatable fabric structure developed by the Goodyear Aircraft Company connecting these extremities. The crew compartment/escape capsule contains only equipment required during

escape, and displays and equipment which are necessary during normal flight. Forward vision is provided during the landing phase by jettisoning the upper half of the nose cap, exposing a window. The escape capsule is of the ballistic type, employing a separation rocket, flaps, and parachutes during the escape sequence.

Contents of the aft pod include secondary power, most of the vehicle electronics, payload, compartment environmental control system, and a liquid-helium inflation system for the fabric structure. Only wire bundles (no fluids, gases, or wave guides) are led through the inflatable structure between the crew compartment and aft pod. A short, rigid section just aft of the crew compartment houses the vehicle's dual reaction control systems, normal $O_2 - N_2$ supply, certain electronics, and other items which are located in the forward section during normal flight but are left behind in event of escape. Surface-mounted hydraulic actuators are provided for rudders and elevons. Rigid-metal fairings protect these actuators.

L
1
1
0
8

The 5-lb/sq ft inflatable vehicle has good tangential landing capabilities. The performance is superior to the X-15 research airplane due to lower wing loading and a higher L/D on approach. Touchdown speed is 73 knots which allows a very short runout distance.

The maximum and minimum longitudinal ranges for the inflatable vehicle (wing loading of 5 lb/sq ft) are 5,850 and 2,900 nautical miles, respectively, and the lateral-range variation from the orbital flight path is 1,400 nautical miles when the maneuver is initiated at 23,000 fps.

The normal altitude exploration corridor between the $C_{L,max}$ equilibrium trajectory and the lower flight limit for this vehicle is 37,000 feet at a relative velocity of 19,000 fps.

The Step I, suborbital Titan booster (fig. 15) modifications include 535 pounds of tank stiffening and 956 pounds of fins (242 square feet). This booster will provide the reentry device with a burnout velocity of 19,150 fps and a range of 2,830 nautical miles. A 400,000-pound-thrust Titan-Centaur booster will provide orbital velocity to this vehicle with a potential growth in weight of 120 pounds.

The aft pod is cantilevered off the booster upper stage, with the deflated fabric structure folded around and forward of it. A structural fairing surrounds the fabric, protecting it and providing the necessary structural connection between the glider nose section and the booster. The fairing is jettisoned just prior to the inflation sequence, which must be performed under low q conditions.

The crew compartment/escape capsule portion of the inflatable vehicle consists of an aluminum-honeycomb inner shell isolated from a high-temperature René 41 outer shell by Fiberfrax insulation. Thin-gage frames of appropriate materials stiffen these shells, and steel longerons support the aluminum structure. The outer shell is coated with a nickelous oxide ablation material of sufficient thickness to insure that the René skin never exceeds 2,000° F. The design surface temperature is below that required for ablation at all times during normal flight. The short, rigid section between the crew compartment and forward fabric area is nonpressurized and consists of René skin over a frame-type structure. Thin-skin water-wall construction with a 0.25-inch layer of Min-K insulation is used for the aft pod. Tracks are provided to facilitate pod installation and removal in the surrounding fabric structure. The fairings which house the control surface servoactuators are formed René 41 sheets.

L
1
1
0
8

The fabric used for inflatable portions of the vehicle is woven of René 41 wire. This material is coated with a silicone elastomer for pressure retention. Maximum allowable temperature is 1,600° F. However, a higher temperature capability is indicated for fabric structures with an inner coating of René 41 foil. The elastomeric coating hardens after exposure to temperatures above 1,000° F and may not be folded again to the small radii required for the launch configuration.

The fabric wing, fins, and control surfaces are constrained to their noncircular cross sections by "drop threads" which are closely spaced René wires which connect the upper and lower surfaces of the section. Neither tubular "backbone" nor the semicircular leading and trailing edges require drop threads.

The inflatable structure is pressurized so that a net compression load cannot exist at any point in the fabric. Shear load provisions include vertical "shear mats" within the wing and two high-pressure tubes located between the fabric backbone and wing upper surface. Gas flow must be modulated to maintain the correct pressure under the constantly varying ambient conditions encountered in flight.

The weights for the inflatable-wing glider for a one-orbit mission are summarized as follows:

	Weight, lb
Reentry vehicle at boost burnout	11,069
Airframe	4,945
Landing gear	210
Propulsion	237
Secondary power	1,284



	Weight, lb
Flight controls	478
Electronics	784
Environmental control	1,189
Crew operations	530
Inflation system	412
Payload	1,000
Reentry vehicle (reentry)	9,860
Reentry vehicle (landing)	8,727

L
1
1
0
8

Folding-Wing Reentry Device

The folding-wing reentry device (fig. 16) is a low-wing-loading (13.4 lb/sq ft) glider capable of reentering the atmosphere from orbit. This configuration was developed by the Lockheed Aircraft Corporation. The low wing loading permits deceleration at high altitudes resulting in relatively low surface heating rates and temperatures. Low temperatures permit the use of presently known and available metals for practically the entire structure. The folding wings reduce the planform area of the vehicle on the booster to that of the intermediate L/D vehicle (330 square feet), yet provide 959 square feet of wing area when extended. The pilot flies the folding-wing glider from a ballistic crew compartment/escape capsule which makes escape possible throughout the flight.

Dual hydrazine APU's generate electrical, hydraulic, and compartment blower power. Dual hydrazine reaction control systems maintain reentry-device attitude during orbit. A separate hydrazine-fueled reaction control system controls the attitude of the escape capsule during emergency reentry. After second-stage burnout, a rocket is used to separate the vehicle from the interstate structure.

The folding wing is a thick slab approximately 4 feet thick. Nose and wing leading-edge radii are 18 inches. The wings fold forward over the top for boost. A ballistic crew compartment/escape capsule is nested in a recess near the nose of the vehicle. Fairings are added ahead of and behind the capsule.

The folding-wing vehicle has good tangential landing capability. At $(L/D)_{max} = 4.4$, the start flare speed is 145 knots and the sink rate is 53 fps.



When maneuver is started at 23,000 fps, this vehicle provides a lateral-range variation of 1,700 nautical miles from the orbital flight path and a potential longitudinal-range variation of 8,300 nautical miles. The normal exploration corridor lies between $C_{L,max}$ and the lower structural limit. The minimum corridor of 27,000 feet occurs at a 20,000-fps velocity.

Modifications on the standard Titan (fig. 17) include the addition of 1,737 pounds of tank stiffening and 3,275 pounds of fins (627 square feet). The burnout velocity achieved with the Step I suborbital booster is 19,300 fps, with a range of 3,485 nautical miles.

The Titan-Centaur booster can provide orbital velocities with a potential growth capability of 8 percent of the gross weight.

The basic material for vehicle skin and structure is René 41 sheet. Spot and seam welding are the principal fastening methods. The body is built around four fore-and-aft trusses consisting of U-shaped caps and box section verticals and diagonals. Gussets are used at the joints. Across the longitudinal trusses run main frames and subframes. The main frames are trusses built in the same manner as the longitudinal frames. The subframes are U-shaped members next to the skin. The material from which these members are fabricated is 0.006 to 0.040 gage. Lower-surface skin panels consist of a smooth 0.004-gage outer sheet with 0.003-gage corrugations. Corrugations without an outer skin are exposed on the upper surfaces.

A heat shield is provided which covers the vehicle nose and forward 16 feet of the undersurface. The shield consists of 0.012 molybdenum separated from the René 41 skin by a thin layer of Fiberfrax insulation. The maximum surface temperature in the protected region is 2,700° F. The maximum temperature of the aft areas, where René 41 is used, is 2,000° F.

The crew compartment/escape capsule structure consists of inner and outer shells separated by insulation. Four stainless-steel longerons plus aluminum Z-frames and skin form the inner pressure shell.

A combination of pin and floating connections at the ends of the longerons supports the inner shell in the high-temperature outer structure. The outer shell is a René 41 skin on Z-frames. Refrasil and Fiberglas insulation reduce heat flow into the capsule. The nose section includes a crushable honeycomb structure to absorb landing impact. A single-point capsule release system is used for maximum reliability.

A weight summary for the folding-wing glider for a one-orbit mission is as follows:

	Weight, lb
Reentry vehicle at boost burnout	8,298
Airframe	2,973
Landing gear	340
Propulsion	200
Secondary power	1,060
Flight controls	424
Electronics	786
Environmental control	985
Crew operations	530
Payload	1,000
Reentry vehicle (reentry)	7,952
Reentry vehicle (landing)	7,715

L
1
1
0
8

CONCLUSION

It is concluded that all the vehicles studied are feasible and capable of achieving reentry from orbital flight. Some of the vehicles represent longer development time and others do not accomplish the Dyna-Soar test mission. The evaluations of the vehicles are presented in a subsequent paper by Max T. Braun entitled "Summary Comparison of Dyna-Soar Reentry Devices."

REENTRY DEVICE CONFIGURATION SPECTRUM

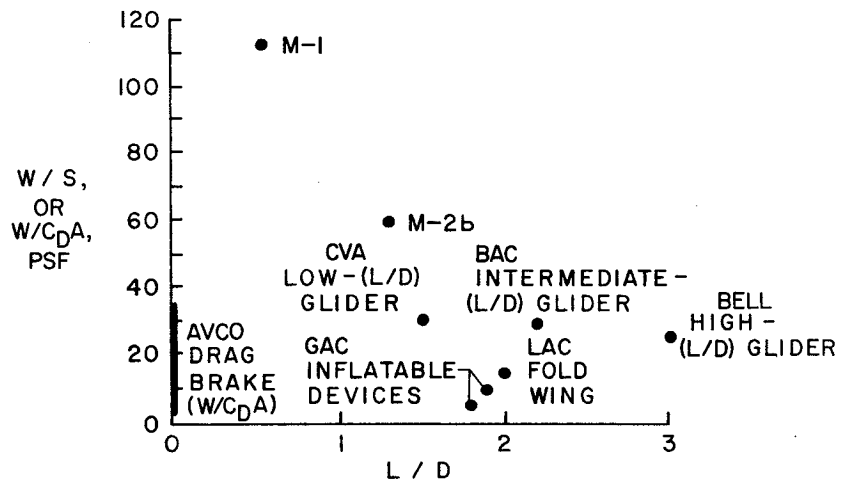

Figure 1

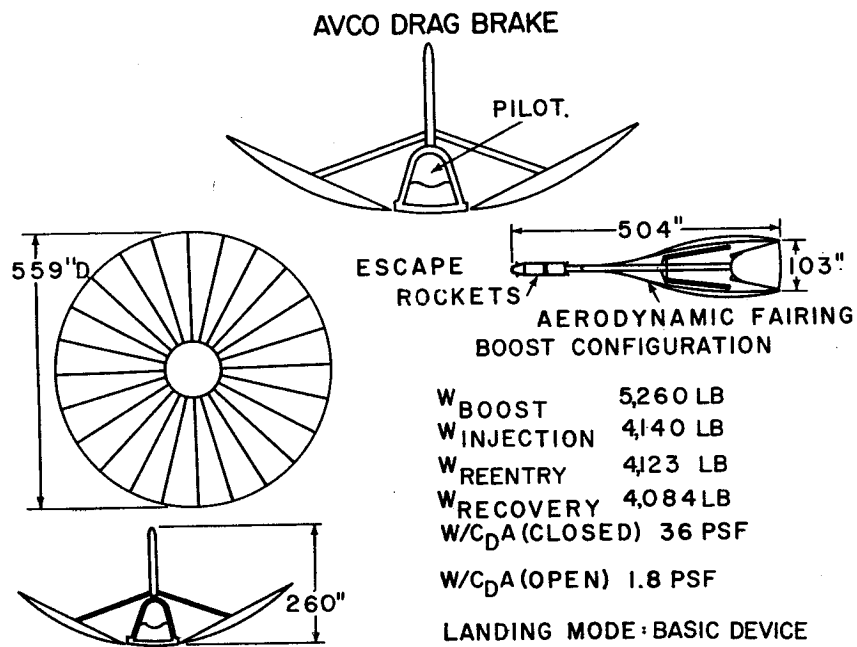

Figure 2

VEHICLE ARRANGEMENT
AVCO DRAG-BRAKE

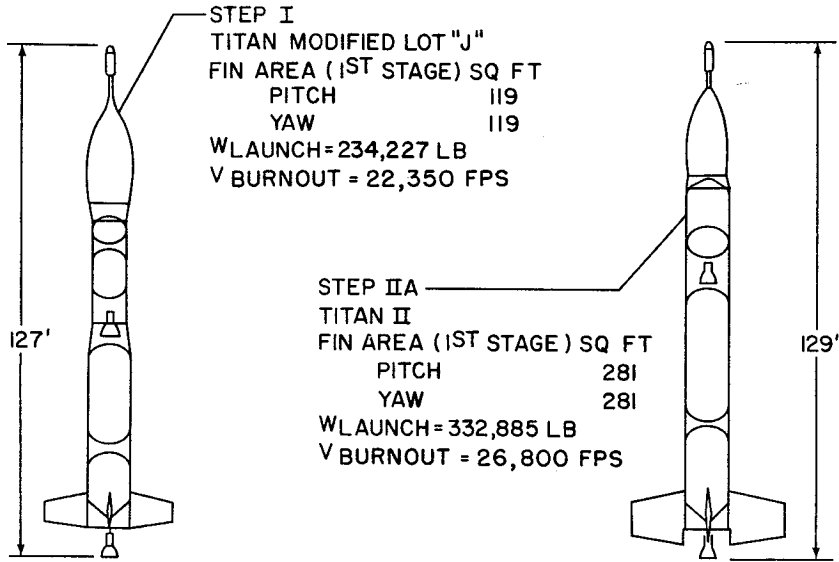

Figure 3

LIFTING BODY, M-1

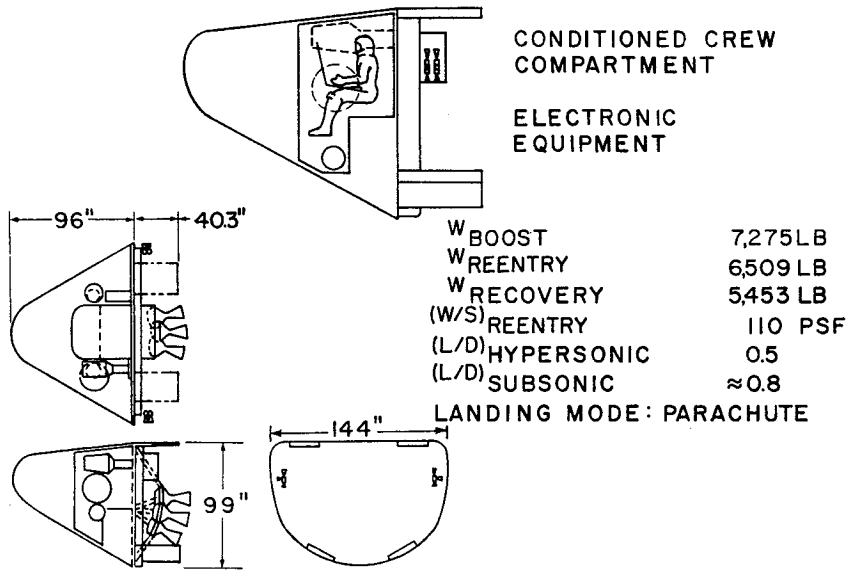

Figure 4

VEHICLE ARRANGEMENT
M-I LIFTING BODY

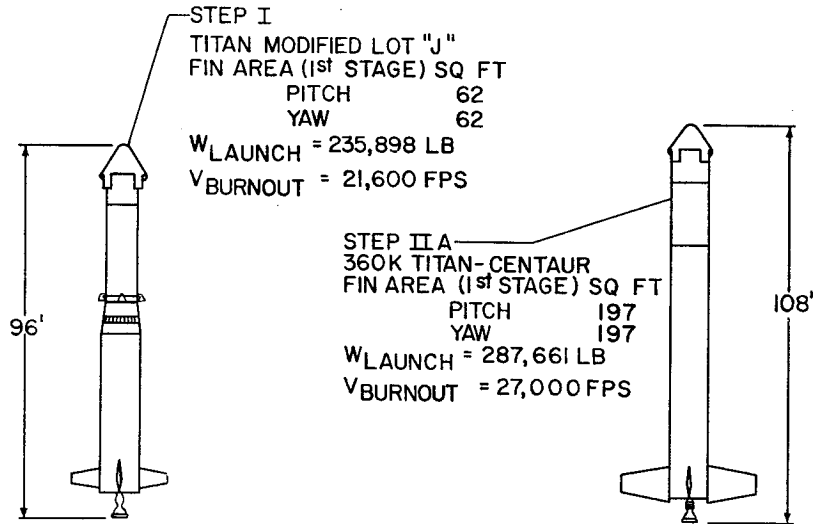

Figure 5

LIFTING BODY, M-2b

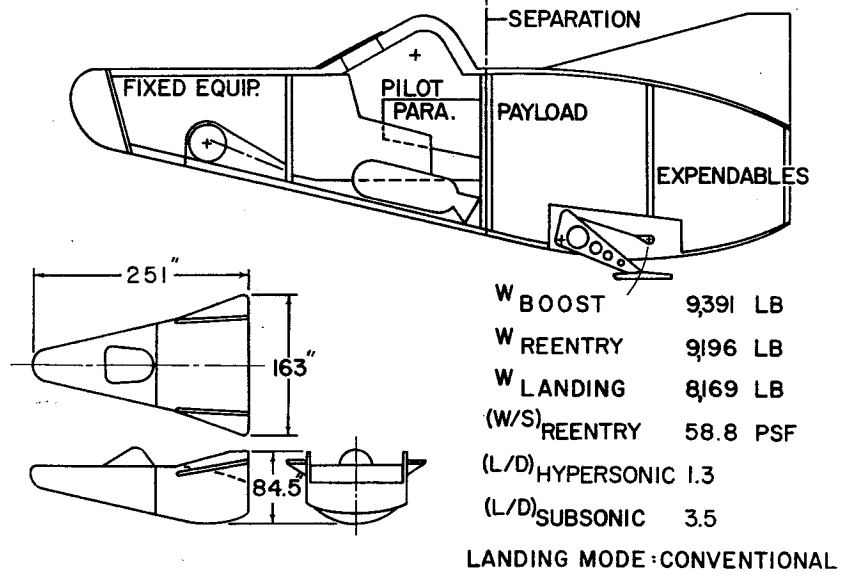

Figure 6

VEHICLE ARRANGEMENT
M-2b LIFTING BODY

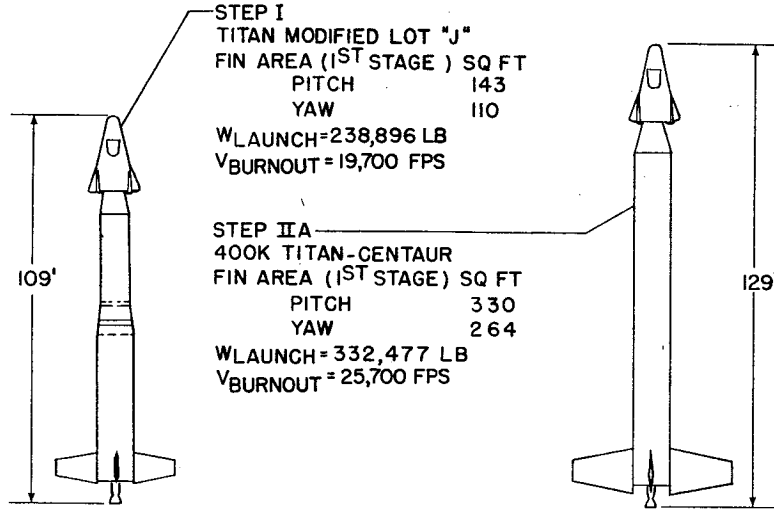

Figure 7

CVA GLIDER, LOW L/D

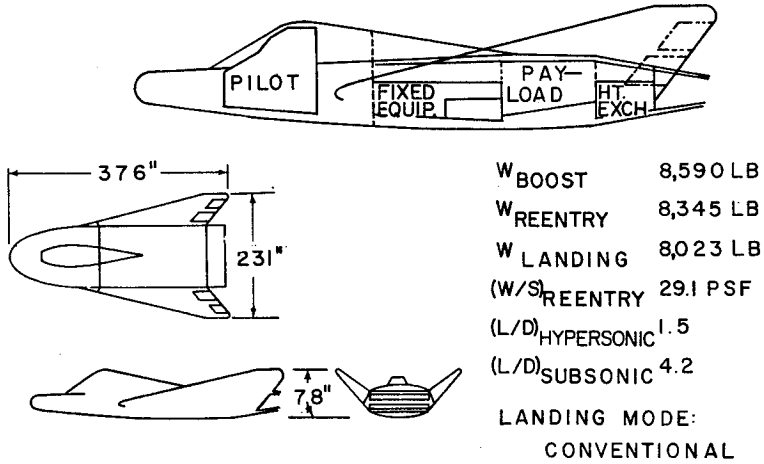

Figure 8

VEHICLE ARRANGEMENT
CVA GLIDER, LOW L/D

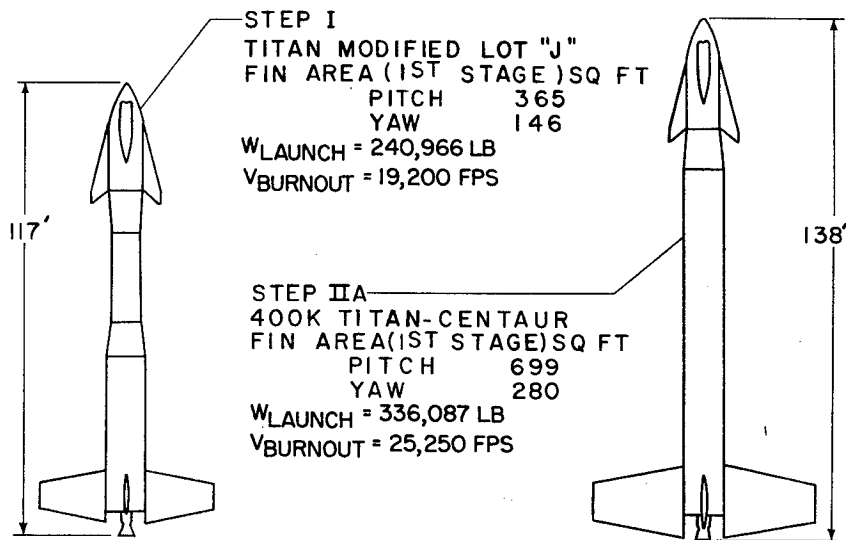

Figure 9

BAC GLIDER, INTERMEDIATE L/D

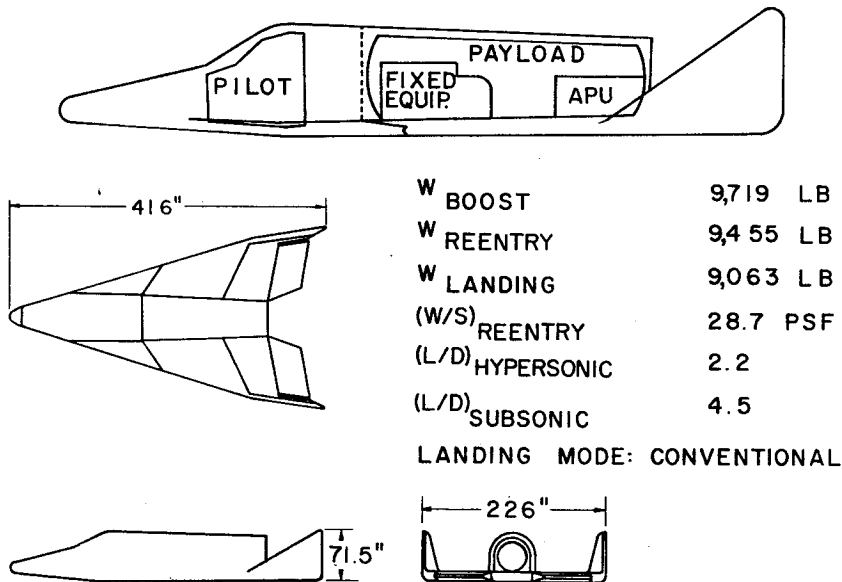

Figure 10

VEHICLE ARRANGEMENT
BAC GLIDER, INTERMEDIATE L/D

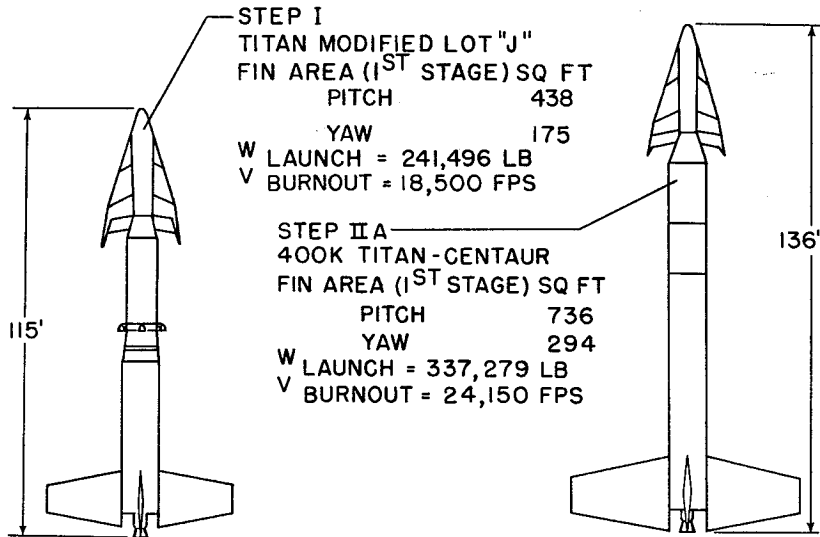

Figure 11

BELL GLIDER, HIGH L/D

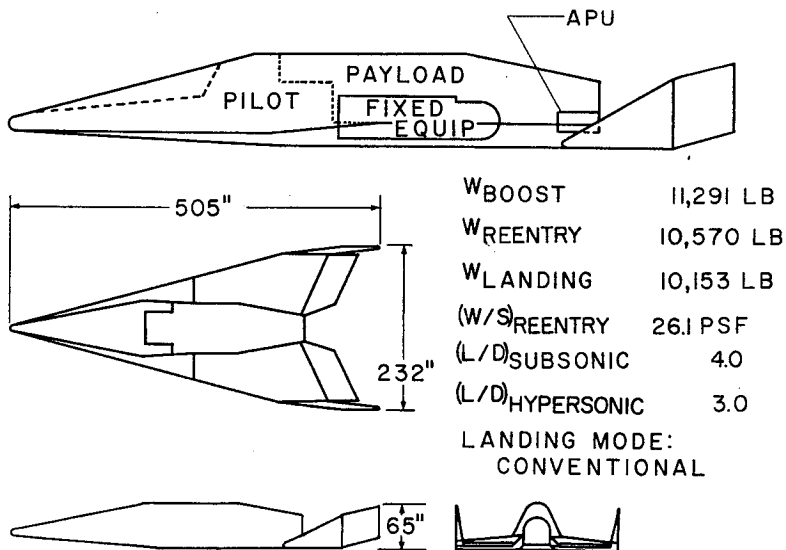

Figure 12

VEHICLE ARRANGEMENT
BELL GLIDER, HIGH L/D

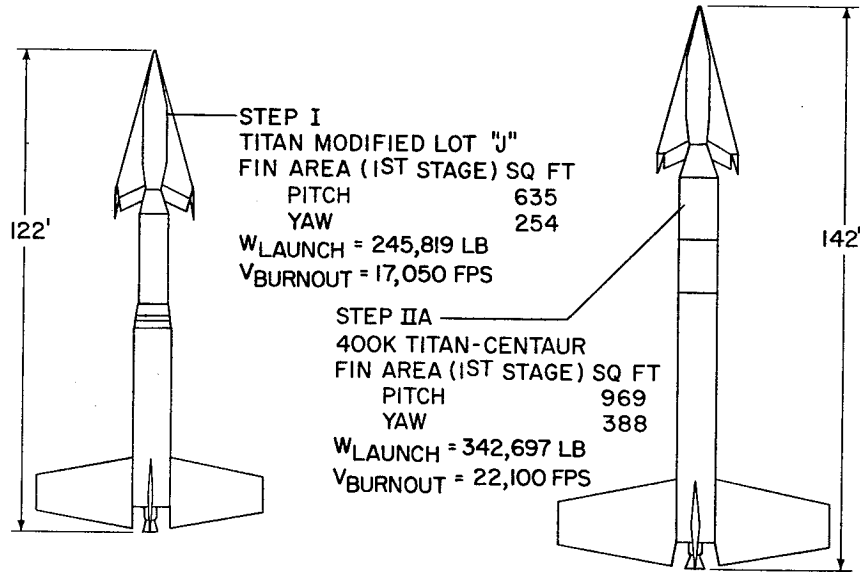

Figure 13

GAC INFLATABLE GLIDER

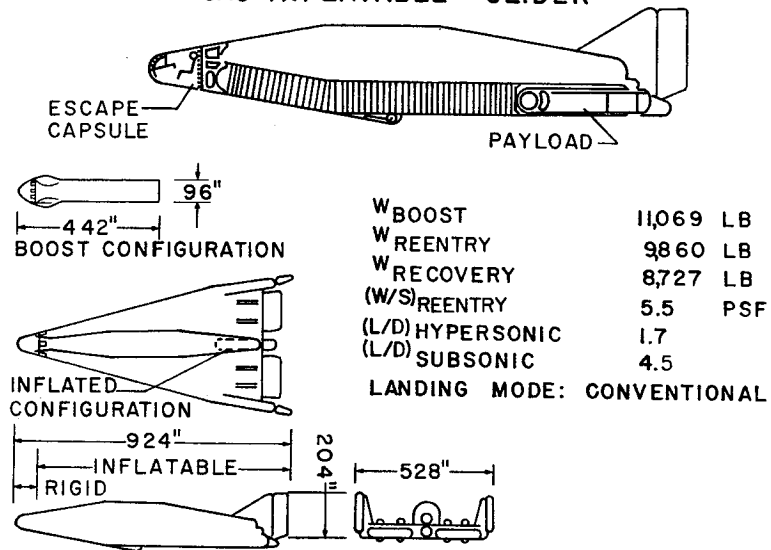

Figure 14

VEHICLE ARRANGEMENT
GAC INFLATABLE

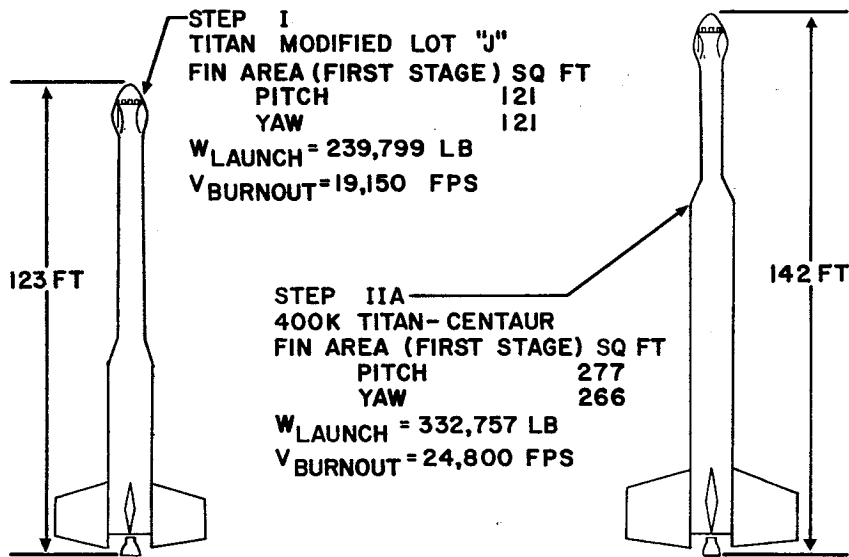

Figure 15

LAC FOLD-WING GLIDER

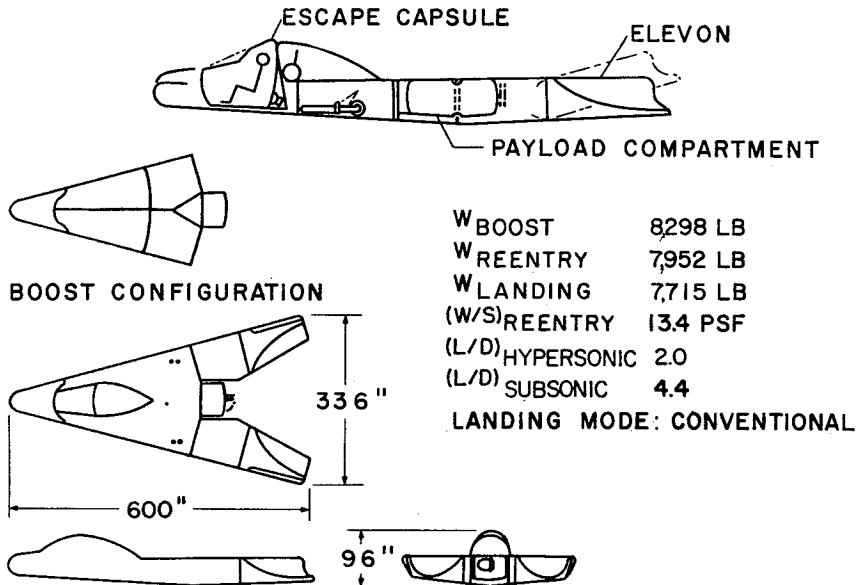

Figure 16

VEHICLE ARRANGEMENT
LAC FOLD WING

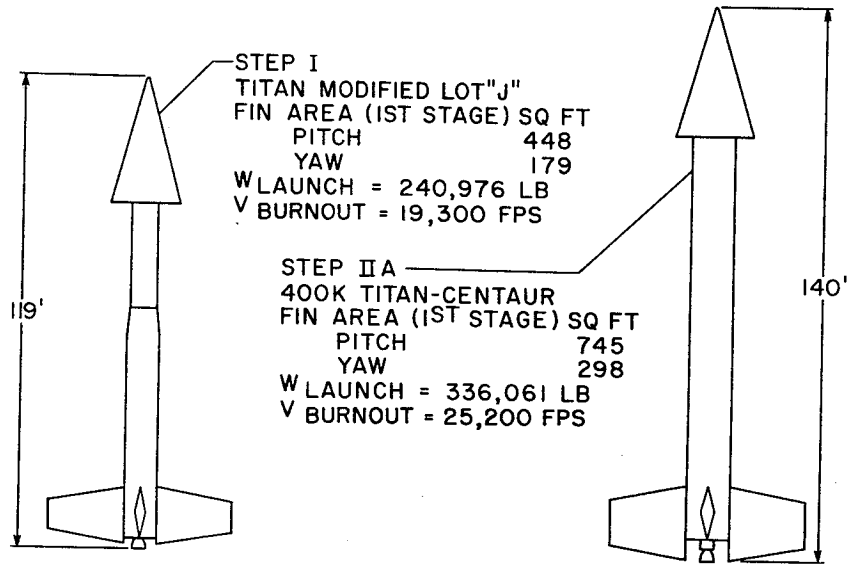

Figure 17

1000

1000

1000

1000

1000

1000

1000