

VKI Preprint 71-7

von KARMAN INSTITUTE FOR FLUID DYNAMICS

PREPRINT 71-7

COMPRESSION OF HELIUM TO HIGH PRESSURES AND
TEMPERATURES USING A BALLISTIC PISTON APPARATUS

by

B.P. Roman, G.P. Rouel, M.J. Lewis and B.E. Richards

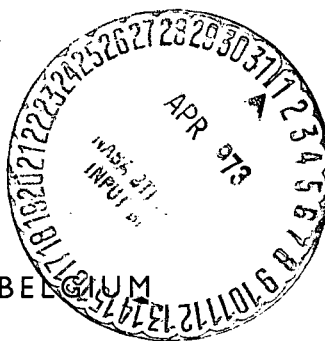

RHODE-SAINT-GENESE, BELGIUM

SEPTEMBER 1971

(NASA-CR-131230) COMPRESSION OF HELIUM
TO HIGH PRESSURES AND TEMPERATURES USING
A BALLISTIC PISTON APPARATUS (Von Karman
Inst. for Fluid Dynamics) 29 p HC \$3.50

©N73-19298

Unclas
CSCL 20D G3/12 65943

28

von Karman Institute for Fluid Dynamics

PREPRINT 71-7

COMPRESSION OF HELIUM TO HIGH PRESSURES AND TEMPERATURES
USING A BALLISTIC PISTON APPARATUS

by

B.P. Roman, G.P. Rouel, M.J. Lewis and B.E. Richards
von Karman Institute for Fluid Dynamics
Rhode-Saint-Genèse, Belgium

September 1971

This research was supported in part by the National Aeronautics
and Space Administration under NASA-Ames Research Grant NGR-013-021.

I

SUMMARY

An initial investigation has been made on the study of the behaviour of helium at high pressures and temperatures. The test specimen was obtained by a shock free compression of helium from room temperatures by a ballistic piston. Volumetric compression ratios up to 300 were achieved. Time-dependent measurements of pressure, volume and temperature were made on the test gas during its compression. The chief results are that temperatures up to $10,000^{\circ}\text{K}$ were estimated to be generated, although an isentropic compression of the test gas to the maximum compression ratio would suggest temperatures more like $20,000^{\circ}\text{K}$ would have been expected. This result was thought to be caused mainly by heat losses by conduction, radiation, ablation of the piston or its seals and the internal energy sink of the ablation products. The temperature measurements were in good agreement with expectations up to $2,500^{\circ}\text{K}$. Measurements of gas temperatures above $3,500^{\circ}\text{K}$ were in error mainly due to surface breakage of the glass of the optical system. Recommendations of future improvements to these tests are given.

LIST OF SYMBOLS

| | |
|-----------|--|
| b | Constant in Equation (2) called "covolume" = 0.024 liters/mole (Ref. 6) |
| C | Constant in Equation (1) |
| n | Polytropic index in Equation (2) |
| P | Pressure |
| T | Temperature |
| V | Volume |
| v | Voltage in Equation (1) |
| ρ | Density |
| λ | Volumetric Compression ratio |
| γ | Ratio of specific heats |

Subscripts

| | |
|---|------------------------------|
| 0 | Reservoir gas |
| 1 | Emission signal |
| 2 | Calibration signal |
| 4 | Compressed gas in the barrel |
| i | Initial conditions |
| g | Gas |
| L | Lamp |

1. INTRODUCTION

In recent years many shock tubes have been developed which are capable of achieving extremely high shock Mach numbers (Ref. 1). The free-piston shock tube (Ref. 2) is a typical example. This type of facility has a high performance by virtue of its high temperature driver gas, which is heated uniformly and adiabatically in a piston compression process. Theoretically the performance of a piston-driven shock tube may be monotonically improved by increasing the volumetric compression ratio of the piston compression process and thereby increasing the temperature of the driver gas (Ref. 3). However, these predictions and the problems involved with achieving very high temperatures through very high compression ratios in a ballistic-piston device have not been explored experimentally.

This report describes some preliminary experiments carried out in the VKI high enthalpy laboratory to investigate the compression of helium, a typical shock-tube driver gas, to very high pressures and temperatures by means of a ballistic piston. The purpose of these measurements was to identify any problem areas in the compression process, to determine the importance of real gas effects during this process and to establish the feasibility of using a ballistic piston apparatus to achieve temperatures in helium in excess of 10,000°K.

2. EXPERIMENTAL EQUIPMENT

The ballistic-piston, barrel (or pump-tube) and reservoir for compressing the helium are shown in Fig. 1-a. The pressure (P_4), density (ρ_4) and temperature (T_4) variations of the helium are measured throughout the reversal of the piston's motion after the first compression stroke. A Kistler 6221 piezoelectric pressure transducer, mounted in the end of the barrel as shown in Fig. 1-b, is used to measure the pressure variation of the compressed helium. The density of the helium is determined from accurate measurements of the piston's position using an eddy current displacement transducer. The piston's position defines the volume of the compressed gas and hence its density. A sodium-line reversal system, shown in Fig. 1-c, is used to measure the temperature of the gas.

These diagnostic techniques are fully described by Lewis et al (Ref. 4). The reader is referred to this report for fuller details. One additional record of the signal from the pressure transducer was made in this series of experiments. This signal was displayed on a Tektronix 502A oscilloscope, with a 50 ms/cm sweep time, to record the piston rebounds. The signal was photographed using a Polaroid Land camera.

3. EXPERIMENTAL APPROACH

The expected high compression ratios and correspondingly high temperatures in excess of $10,000^{\circ}\text{K}$, introduced the following problems :

a. The strength of the thin nylon seals at the front end of the piston was uncertain at these temperatures. It is imperative that leaks be avoided at high temperatures and high pressures, since severe burning of even hardened steel can be caused. The action is similar to that caused by an oxy-acetylene flame-cutter. Such burning has been found in many advanced wind tunnel facility nozzle throats (e.g. use of tungsten in Hotshot and Longshot tunnels) and has occurred in the von Karman Institute's Longshot valve system. Later in the report it will be shown that the test series was terminated by such a problem. The thin nylon seals were therefore replaced initially by a large block seal of nylon, as shown in Fig. 2. The disadvantage of such a large seal is that it deforms at high pressure. This deformation introduces an uncertainty into the volume measurement. An approximate correction was made to account for the deformation in the data reduction.

b. Holbeche and Woodley (Ref. 5) have demonstrated that the sodium-line-reversal temperature measurement technique cannot be used with confidence to measure the temperature of a monatomic gas at pressures less than one atmosphere. However, it was thought that due to the relatively high pressure environment of the present experiments, and because the helium was seeded locally with nitrogen and sodium (from the decomposition of NaN_3), the temperature measurements would be valid.

c. The upper limit of accurate temperature measurements with the system as described in Ref. 4 was expected to be approximately 2500°K . Higher temperature measurements were attempted in this dense helium study using a relative "black-body".

d. The pressure gauge suffers from errors due to thermal response. Errors from this source were minimised by placing

a thin layer of asbestos over the front surface of the gauge.

Mindful of these problems, the experiments were divided into the following two logical groups :

1. A series of tests with low compression ratios giving temperatures less than 2500°K. The sodium-line-reversal system was used as described by Lewis et al (Ref. 4). These measurements would verify whether or not the technique was valid under the present circumstances.

One unforeseen problem arose with these low volumetric compression ratio tests; the grooves on the piston did not reach the piston position transducer. A long lead pin was used to give the compressed gas volume at peak pressure. This was the only piston position measurement possible in this group.

2. Measurements at high volumetric compression ratios giving temperatures in excess of 2500°K.

To determine the temperature of the helium in these tests, it was assumed that the emission of the sodium atoms was "black-body". Some confirmation of this assumption, with nitrogen as the test gas at pressures greater than 1500 kg/cm², may be found in the work of Lewis et al (Ref. 4). Prior to each test, a square wave calibration signal, obtained by mechanically chopping the background source (which was at a known brightness temperature), was recorded with a very high gain on the oscilloscope's vertical amplifier. During the test, the lamp and "chopper" system were not employed and only the emission from the compressed gas was monitored by the photomultiplier. During the test the vertical amplifier gain on the oscilloscope was changed to a very much smaller value than in the calibration. If the emission from the sodium is "black-body", the electronic temperature of the sodium and hence the helium temperature is given by :

$$\frac{1}{T_g} = \frac{1}{T_L} + C \ln \frac{v_2}{v_1} \quad (1)$$

where T_g is the gas temperature, T_L is the lamp brightness temperature, C is a constant, v_1 is the recorded emission voltage during a test and v_2 is the calibration voltage.

It is stressed that this temperature measurement relies on two, as yet unproved, assumptions; the validity of the sodium line reversal technique in monatomic gases (this will be demonstrated by the results from the group 1 tests) and the "black-body" emission of the sodium at high pressures. This last assumption could not be verified without using a very high intensity flash lamp, which was not available.

The measurements of pressure and piston position, in the group 2 tests, were carried out using the methods described by Lewis et al (Ref. 4).

4. RESULTS AND DISCUSSION

4.1 Recorded data and data reduction

Typically recorded oscillograms from each group are shown in Figs. 3, 4, 6, 7. The emission signals in the group 2 temperature oscillograms are the upper traces. Two typical sets of reduced data, one from each group of tests, are shown in Figs. 5 and 8.

4.2 Overall correlation of results

The capability of achieving high compression ratios in this particular facility is illustrated by Figs. 9 and 10 which show P_4/P_{4i} and λ versus P_0/P_{4i} . The experimental points are taken from the measurements at peak conditions. The theoretical curves were calculated by assuming that the helium behaves as an Abel-Noble gas, that it was compressed isentropically, and that the reservoir gas expanded isentropically with an infinite sound speed. The discrepancy and the scatter in the results is mainly due to piston friction; the piston seals were renewed after each test and it was noticed that some seals were tighter than others in the barrel. Compression ratios in excess of 300 were obtained.

If the compression process was isentropic a compression ratio of 300 would indicate that a temperature in excess of $20,000^\circ\text{K}$ had been obtained assuming that the gas obeyed an Abel-Noble equation of state. Such temperatures were not in fact achieved for the following reasons.

1. Radiation, convection and conduction heat losses to the chamber walls occurred.
2. Black deposits of a carbon-like quality were formed from the nylon seals at high temperatures, thus showing that heat was lost through ablation of the nylon.
3. Impurities in the test gas itself and from the black deposits are internal energy heat sinks.

To demonstrate the "entropic" compression process, Fig. 11 is presented, where a polytropic compression of an Abel-

Noble gas has been assumed, such that

$$P(V - b)^n = \text{Constant} \quad (2)$$

This equation has been selected since under the present circumstances the Abel-Noble equation of state is thought to be more appropriate than the perfect gas equation (Ref. 6). The exponent n may be compared to the exponent γ ($=1.667$ for pure helium) in the isentropic cycle given by $P(V - b)^\gamma = \text{constant}$.

The polytropic index n was calculated from the pressure and volume data between initial conditions and conditions experimentally measured at the particular time indicated in the abscissa of Fig. 11. If the compression process were isentropic and the gas was pure helium then n would be expected to be constant and equal to 1.667. In fact Fig. 11 shows that n decreases around peak conditions and that n also decreases from test to test as higher compression ratios are achieved. With more controlled tests than were carried out in this study, it is expected that such a plot would help locate the various sources of the non-isentropicity.

In order to correlate all of the measured temperature information collected in this series with the measured pressure and volume information, values of n as determined from P_4 and V_4 at peak conditions were plotted as a function of λ . A least squares fit to this information is shown in Fig. 12. The peak temperature was then determined as a function of λ from

$$\frac{T_4}{T_{4i}} = \left(\frac{V_{4i}}{V_4 - b} \right)^{n-1} \quad (3)$$

The results of this calculation are represented by curve B on Fig. 13 where the helium temperature is shown as a function of λ . Curve B, in effect, describes the mean of the temperatures calculated in each run from peak pressures and volumes using an Abel-Noble equation of state, $P(V - b) = RT$.

Curve B may be compared with the temperature that would be achieved by the isentropic compression of 1 mole of helium obeying an Abel-Noble equation of state (curve A), and with the measured temperatures. This figure illustrates more clearly the effect of heat losses from the gas sample.

The agreement between the experimental points and curve B at values of λ less than 60 gives confidence in the assumption that the line-reversal technique is satisfactory. The discrepancy between curve B and the measured temperatures at high compression ratios is thought mainly to be due to the pitting of the prisms under these conditions. The results summarised in Fig. 13 clearly suggest that temperatures approaching $10,000^{\circ}\text{K}$ were indeed achieved and that, provided pitting could be avoided, the "black-body" intensity ratio method of measuring temperature in group 2 could be a satisfactory one.

4.3 Uncovered problem areas

This series of tests brought out many unforeseen problems and difficulties which could not be solved or rectified during the short time available to perform the tests. The main problems encountered are listed as follows :

1. At very high pressures $\sim 2700 \text{ kg/cm}^2$, the pressure gauge overloaded. This gauge is designed for operation up to 2500 kg/cm^2 . The manufacturers had indicated that it could operate above this limit.

2. Electrical malfunctions of trigger systems and initial alignment problems with the very sensitive position measurement transducer caused several tests to be wasted.

3. Pitting of the glass prisms at high temperatures and pressures. This was probably due to local stress concentrations caused by high temperature gradients in the glass. This entailed changing the prisms after each test - a difficult time consuming task. Pitting introduced uncertainties into the temperature measurement results.

4. Leakage at high pressures caused by fracture of prisms or failure of seals. Leaks were easily detected after a test.

5. Heavy carbon-like deposits at high temperatures caused by "burning" or ablation of the nylon seals. This deposit was reduced by replacing the block nylon seal with the original thin nylon seals after Run 20, and also by using different seal material. Ertalon 6SA, Ertalon 6XAU, Crossflon 403. Subjectively, Ertalon 6XAU appeared to be the best material tested.

6. Damage to the interior of the end of the barrel due to a break down in the piston front seal (Run 24).

5. CONCLUSIONS AND RECOMMENDATIONS

From these preliminary tests the following conclusions may be drawn :

a. Volumetric compression ratios in excess of 300 may be safely achieved in the present pump tube, suggesting that temperatures in helium up to 20,000°K are possible.

b. Heat losses, ablation and the internal energy sink of the ablation products prevented temperatures in excess of 10,000°K from being achieved.

c. The sodium-line-reversal technique may be used with reasonable confidence to measure temperatures up to 2500°K in helium at high pressures.

d. Pitting of the glass prisms prevented a good assessment of the gas temperature from being made at temperatures above 3500°K, using the "black-body" temperature-ratio thermometric technique.

e. No firm conclusions can be drawn about this "black-body" technique, but the results are very encouraging.

It is recommended that efforts be made to reduce the pitting in the prisms by employing special glass. Non-ablating, high strength, possibly asbestos based, materials should be employed to reduce and possibly eliminate the ablation effects. Heat transfer measurements should be made by mounting a calorimeter gauge in the compression chamber to measure directly the radiative and conductive heat losses. In this way it will be possible to experimentally determine which is the most important heat loss mechanism. The pressure gauge used in these measurements should be replaced by a gauge with a higher upper pressure limit.

ACKNOWLEDGEMENTS

Discussions of the work with Professors Jean Smolderen and John Wendt of the von Karman Institute were greatly appreciated. The rapidity with which the experimental part of the study was carried out was due to the help and interest of Jean Hugé and Fernand Vandenbroek. Mlle Isabelle Wuilbaut typed the manuscript.

REFERENCES

1. Enkenhus, K.R. : "Intermittent Facilities", VKI Short Course on Advanced Shock Tube Techniques. von Karman Institute Lecture Series II, Vol. 1, February 1969.
2. Lewis, M.J. : "A Description of the VKI Piston Driven Shock Tube", von Karman Institute TM 20, December 1970.
3. Stoddard, F.J. : "Research on Advanced Gas Dynamic Test Facilities", Part 1, Aerospace Res. Labs., ARL 70-0235, October 1970.
4. Lewis, M.J., Roman, B.P., Rouel, G. : "Techniques for Measuring the Thermodynamic Properties of a Dense Gas", Proc. IEEE 4th Int. Cong. on Instrumentation in Aerospace Simulation Facilities, Rhode-Saint-Genèse, June 1971, or von Karman Institute TM 23.
5. Holbeche, T.A., Woodley, J.G. : "Spectrum-Line-Reversal Temperature Measurements through Unsteady Rarefaction Waves in Vibrationally Relaxing Gases", AGARD CP No. 12, Vol. 2, p. 507, 1967.
6. Siegel, A.E. : "The Theory of High Speed Guns", AGARDograph 91, May 1965.

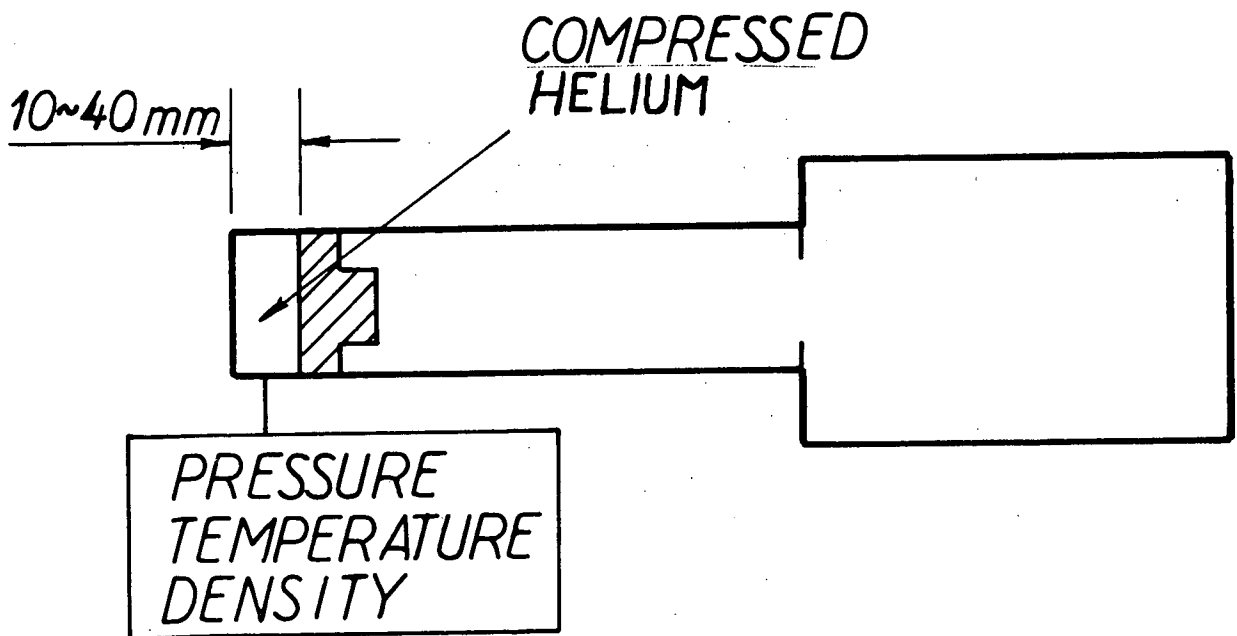
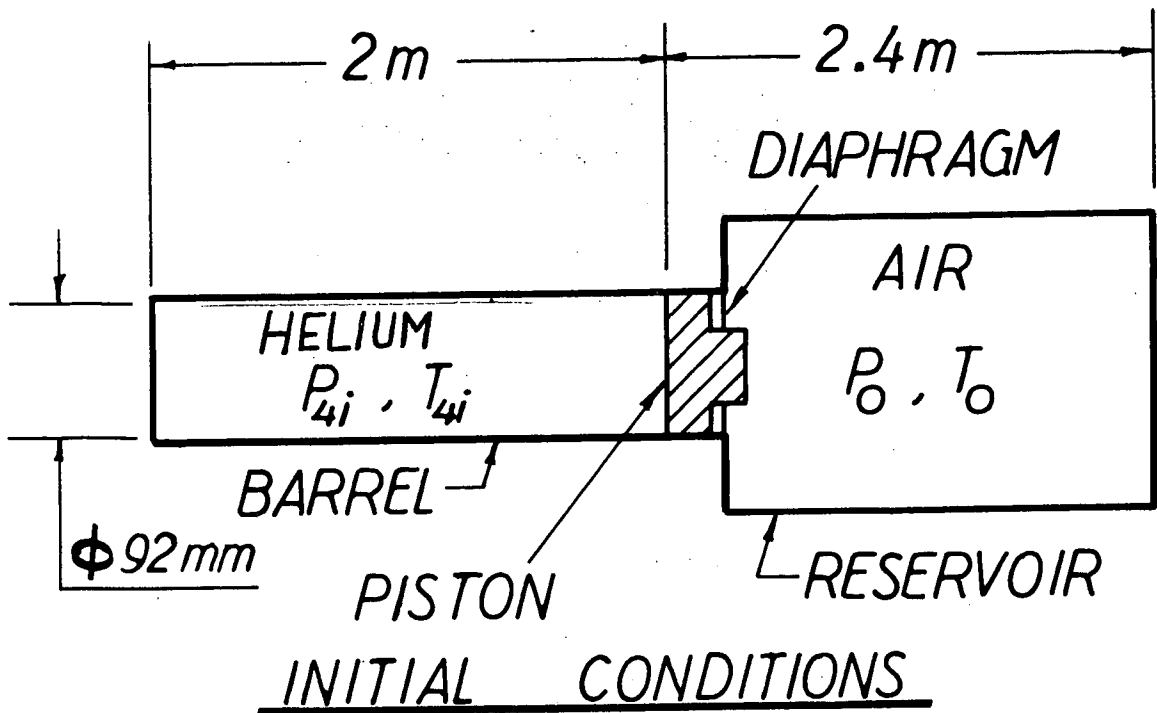

MEASUREMENT CONDITIONS

FIG. I-a - GAS COMPRESSION SYSTEM

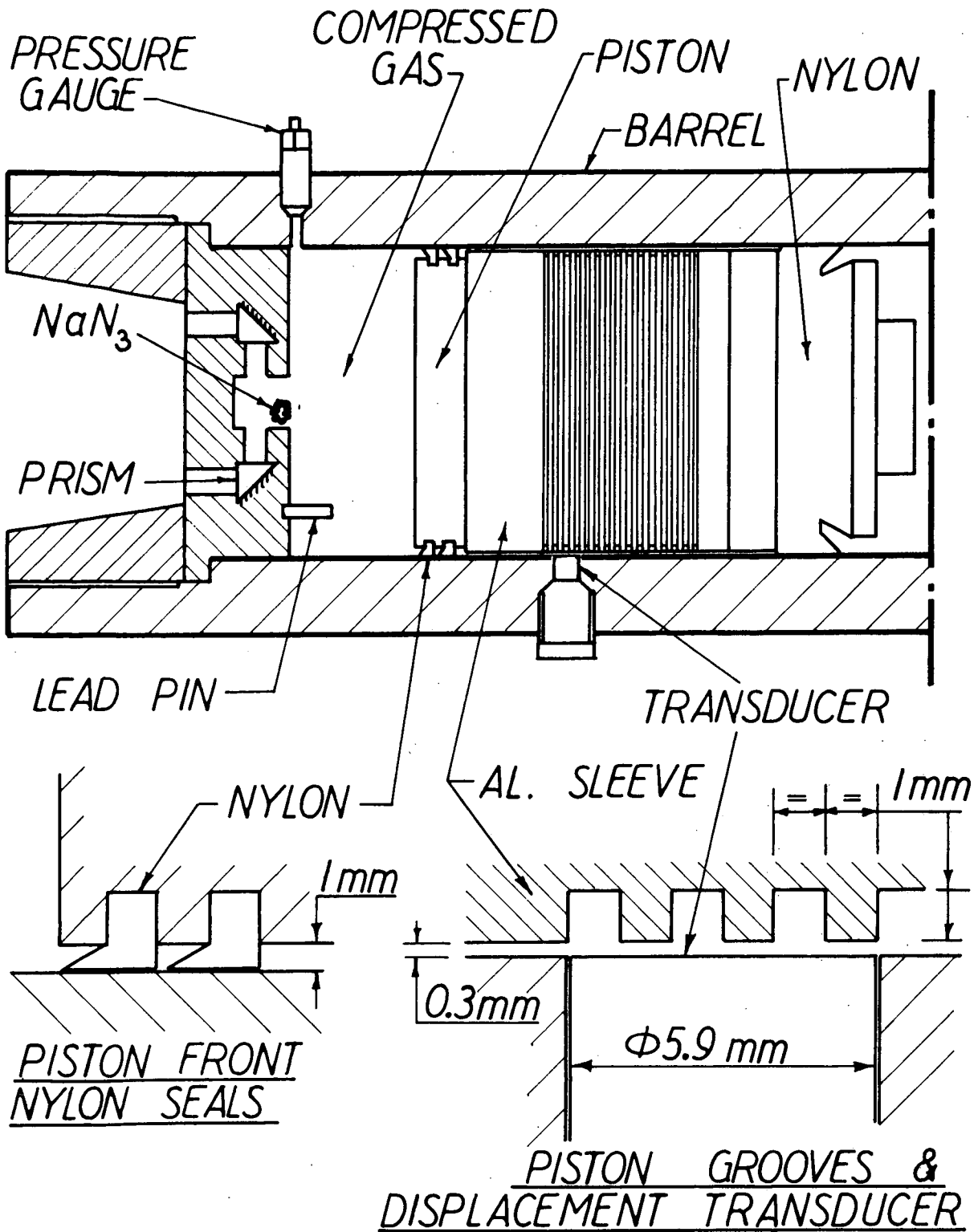

FIG. I-b - COMPRESSION CHAMBER, PISTON, BARREL END WALL AND MEASUREMENT TRANSDUCERS

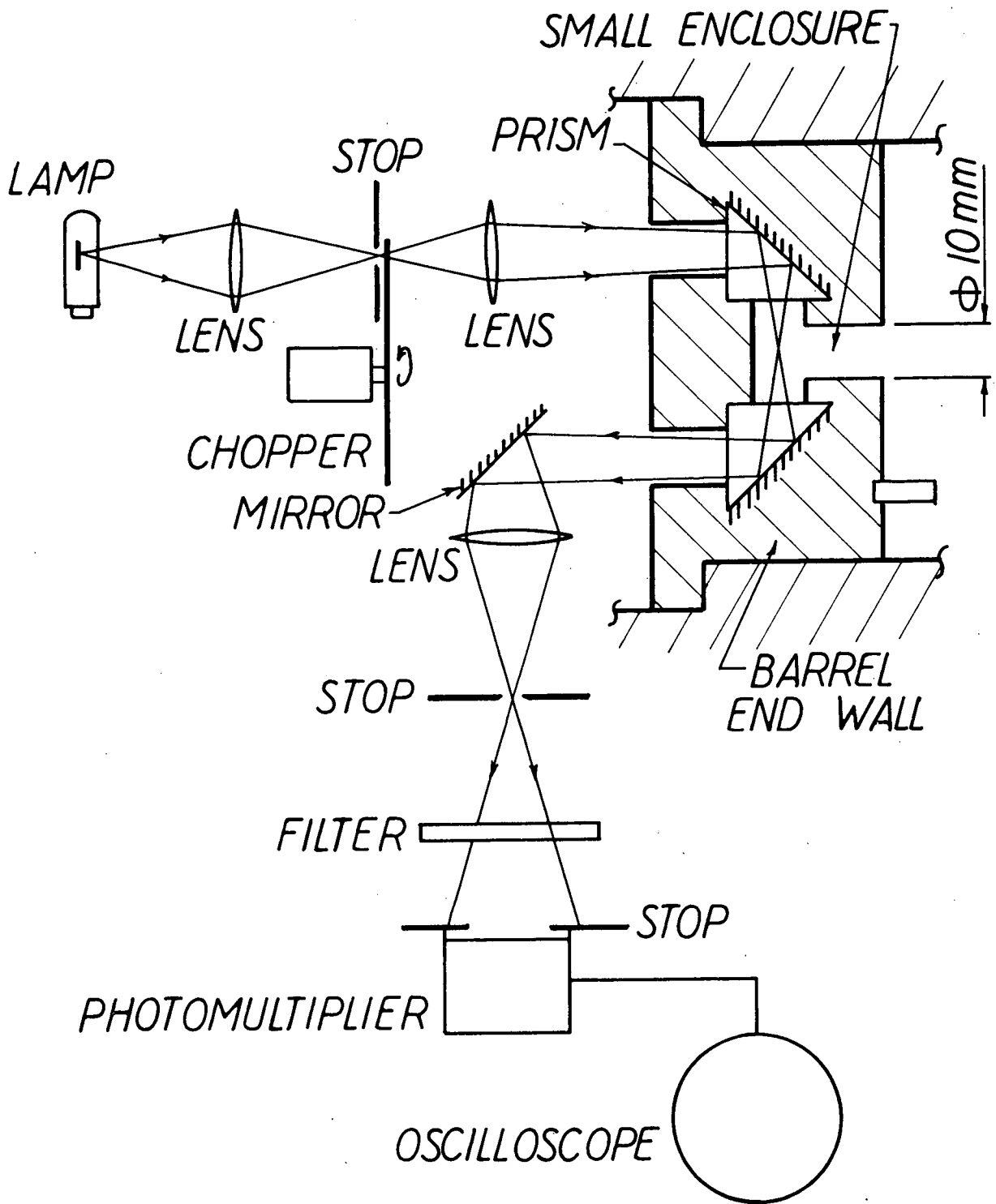
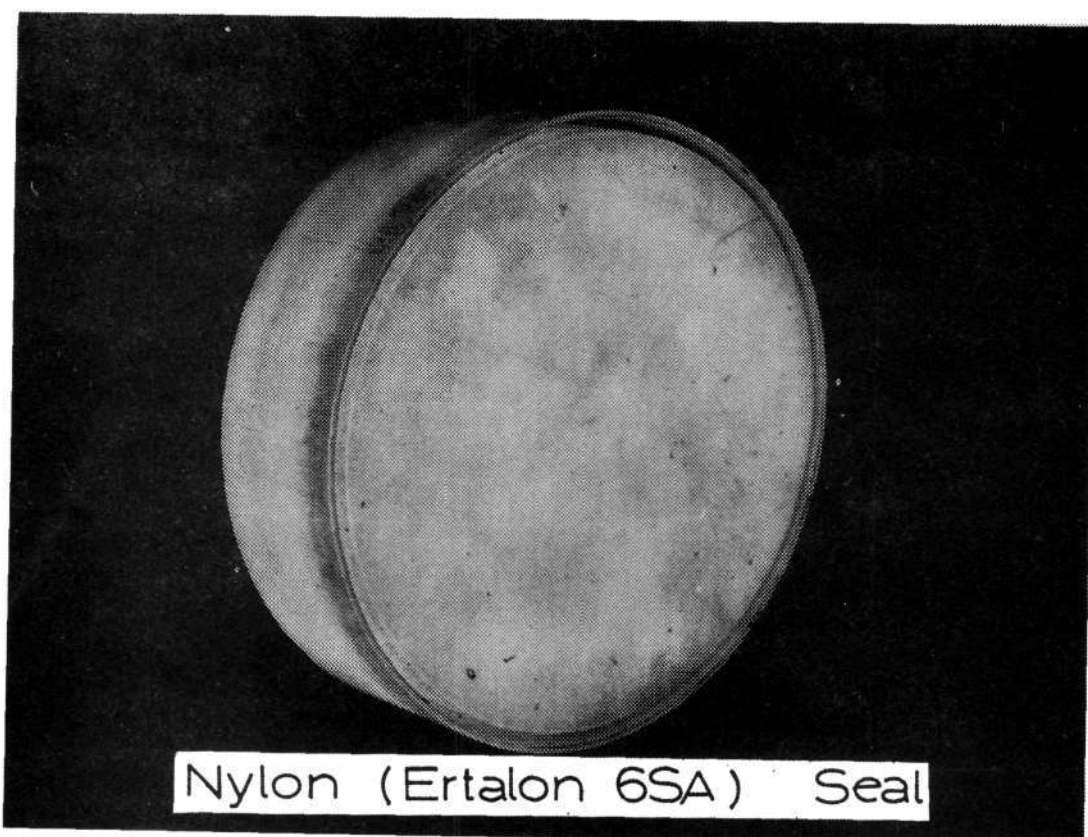
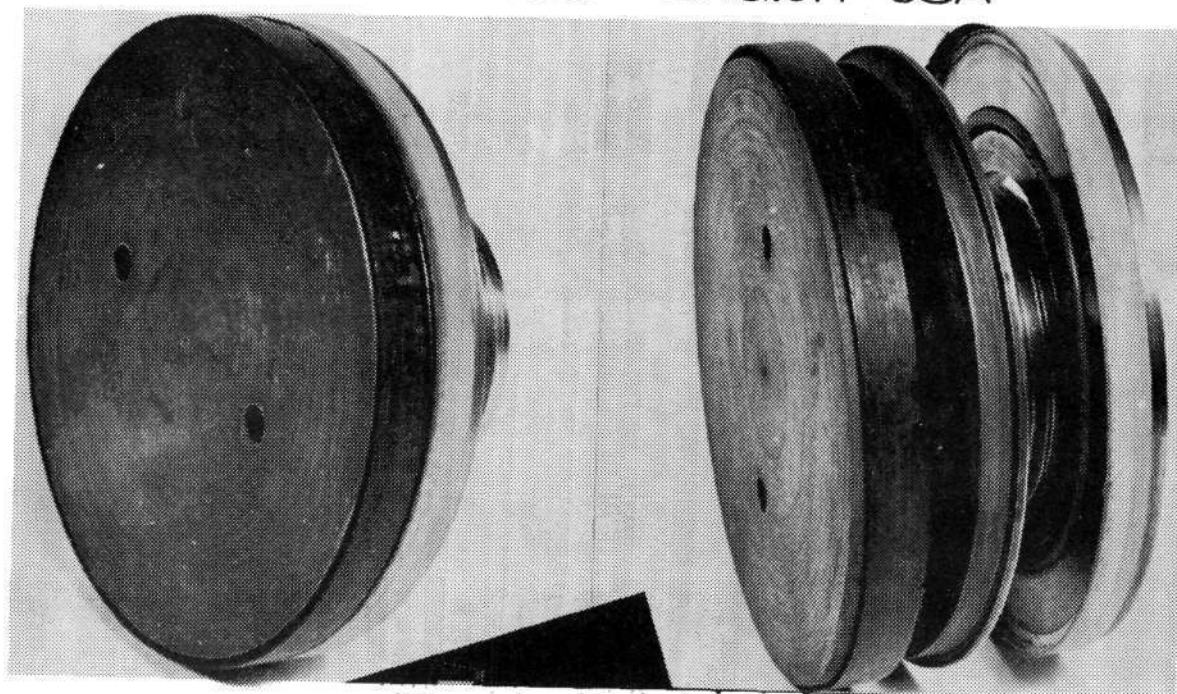

FIG. I-c - SINGLE-SOURCE, EFFECTIVE DOUBLE BEAM, SPECTRAL LINE REVERSAL SYSTEM



Nylon (Ertalon 6SA) Seal

Rear - Ertalon 6SA



Front - Ertalon 6XAU

Nylon Rings on Steel Support

FIG.2 Piston Front Seals.

GROUP 1

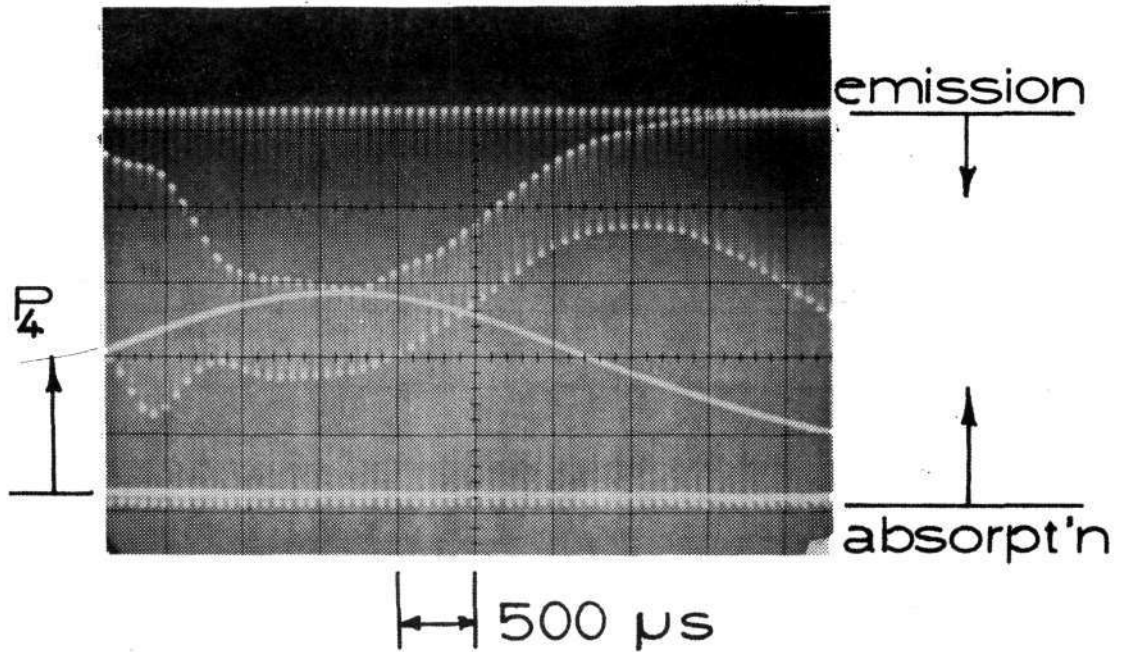

FIG. 3 Temperature & Pressure Oscillogram

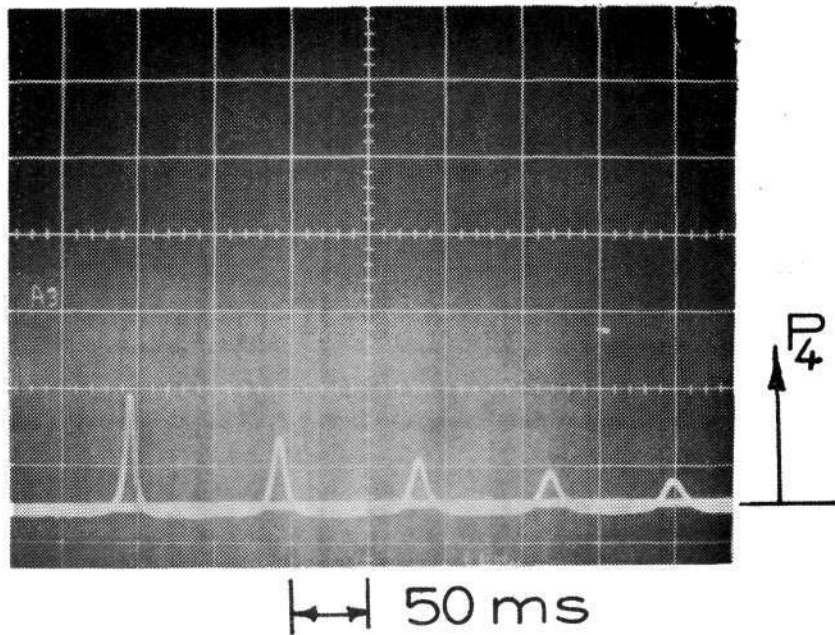

FIG. 4 Pressure "Rebound" Oscillogram

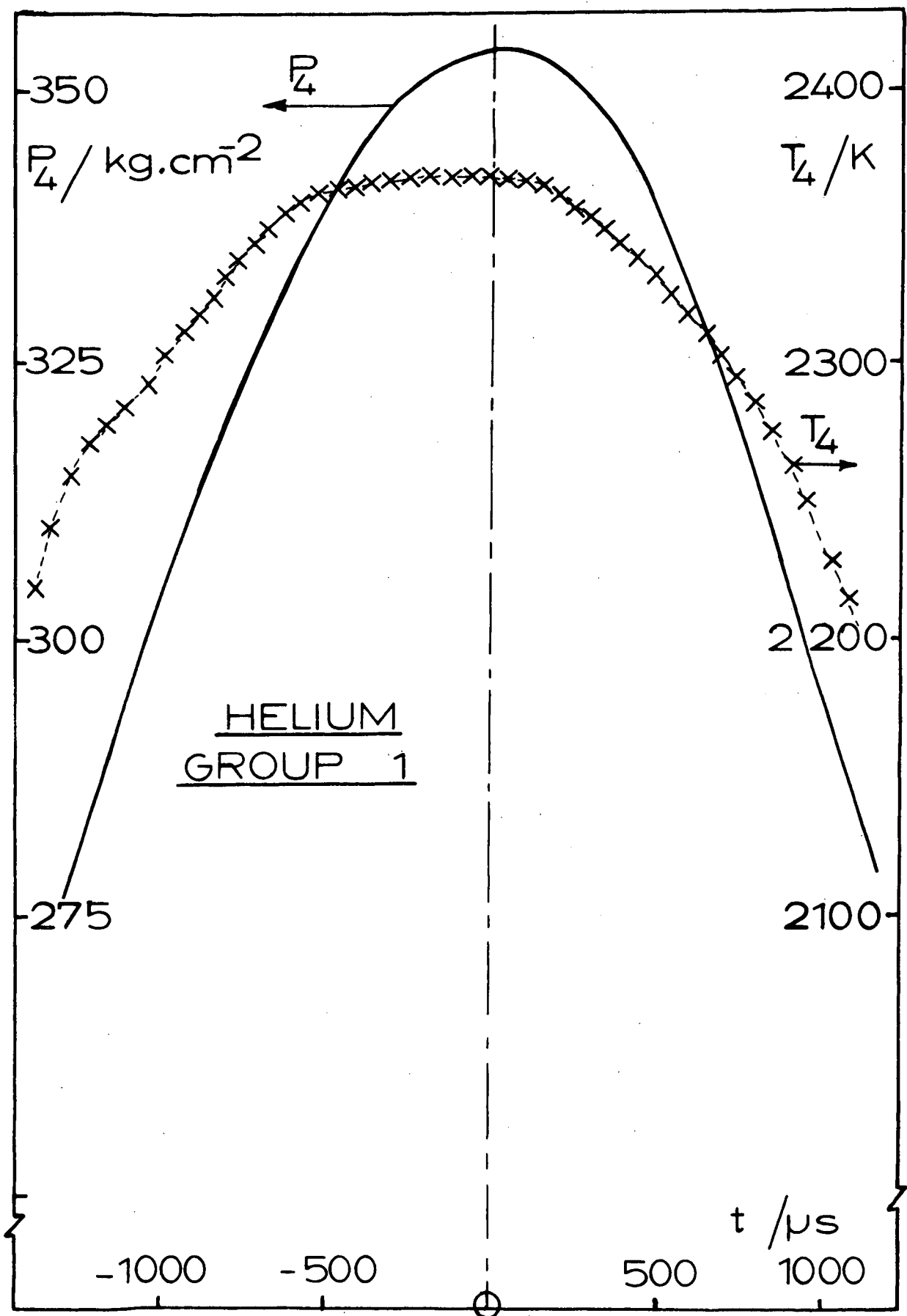

FIG. 5 Pressure & Temperature Results

GROUP 2

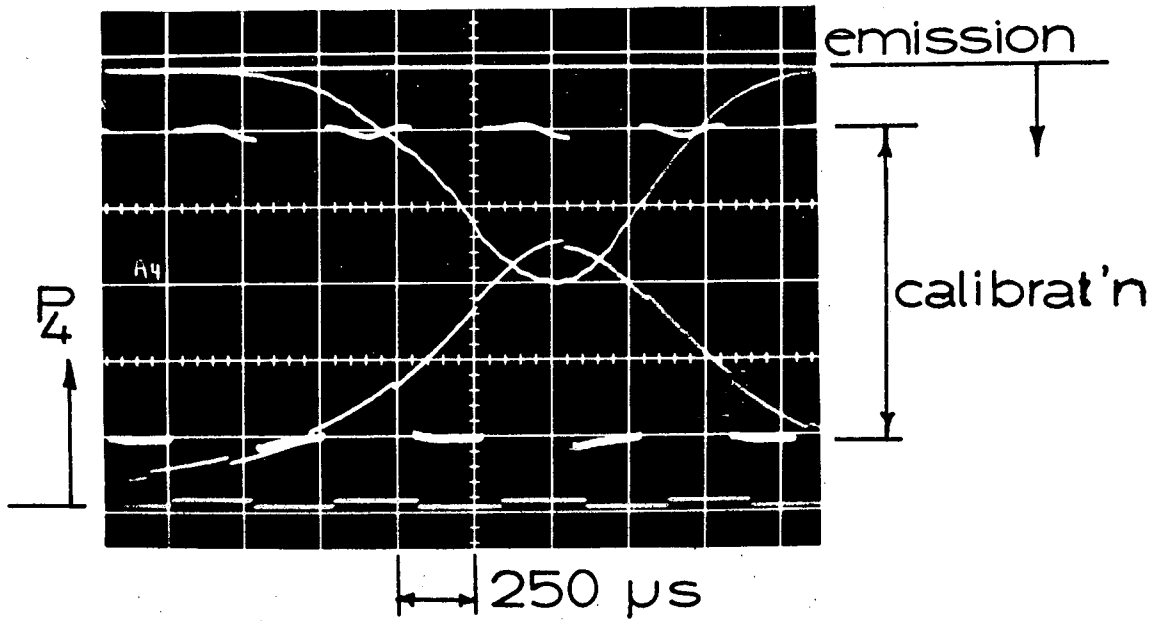
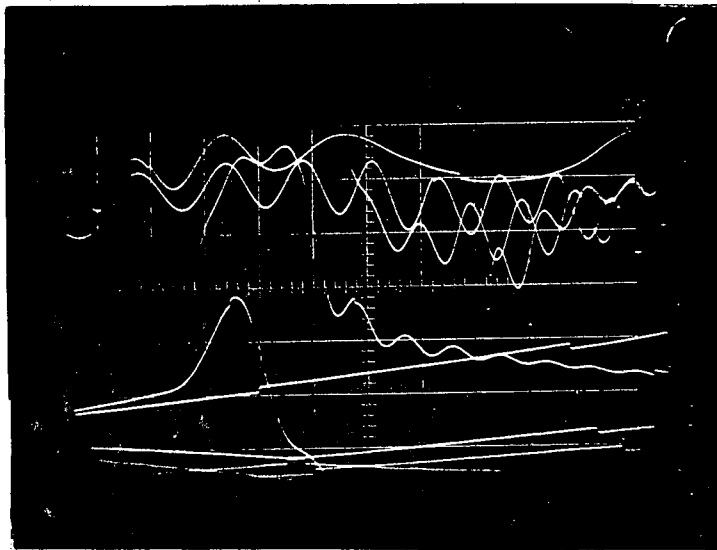

FIG. 6 Temperature & Pressure Oscillogram

minimum volume ↓



50 μs

FIG. 7 Piston Position Oscillogram

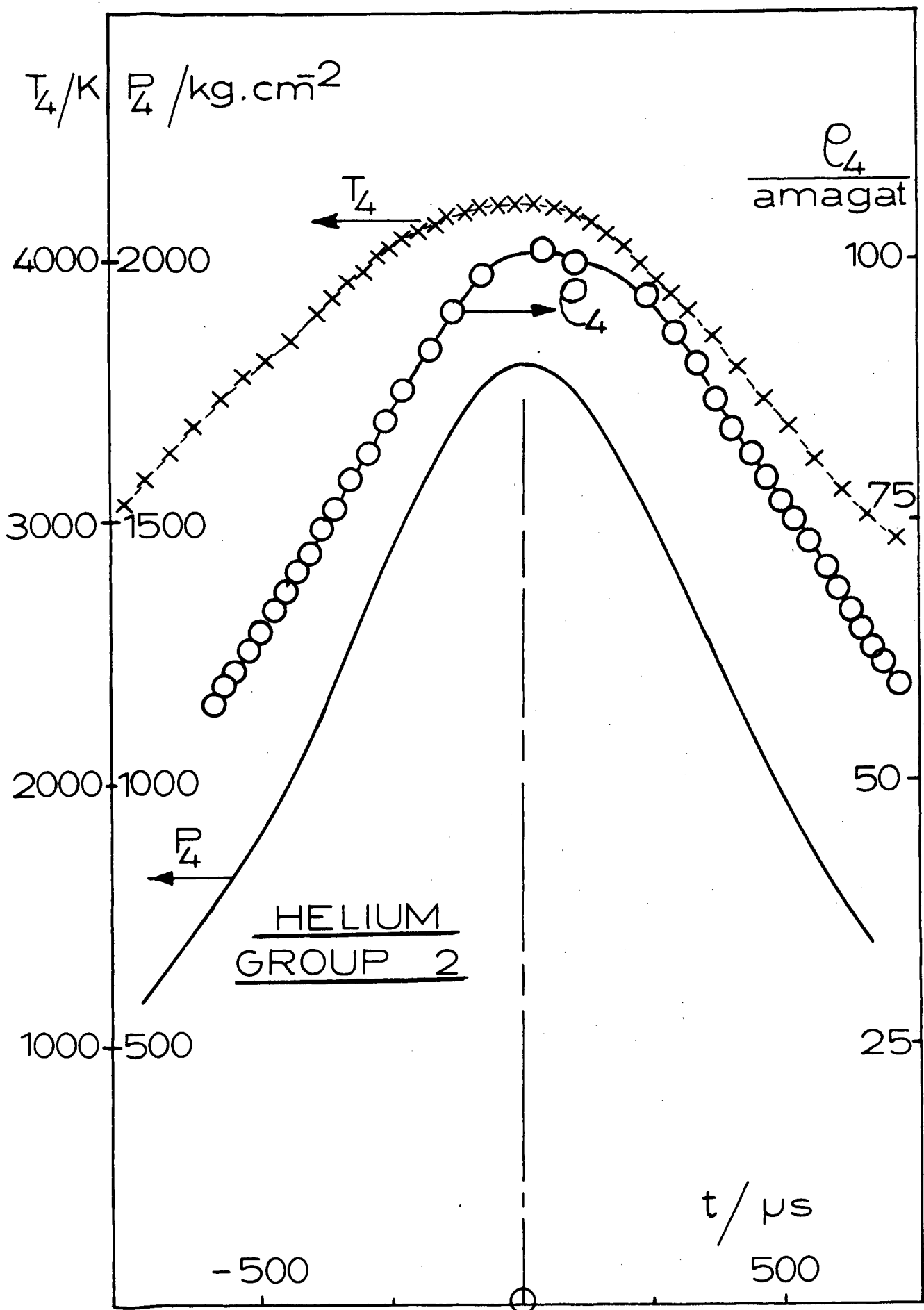

FIG. 8 Pressure Temperature & Density - Typical Results

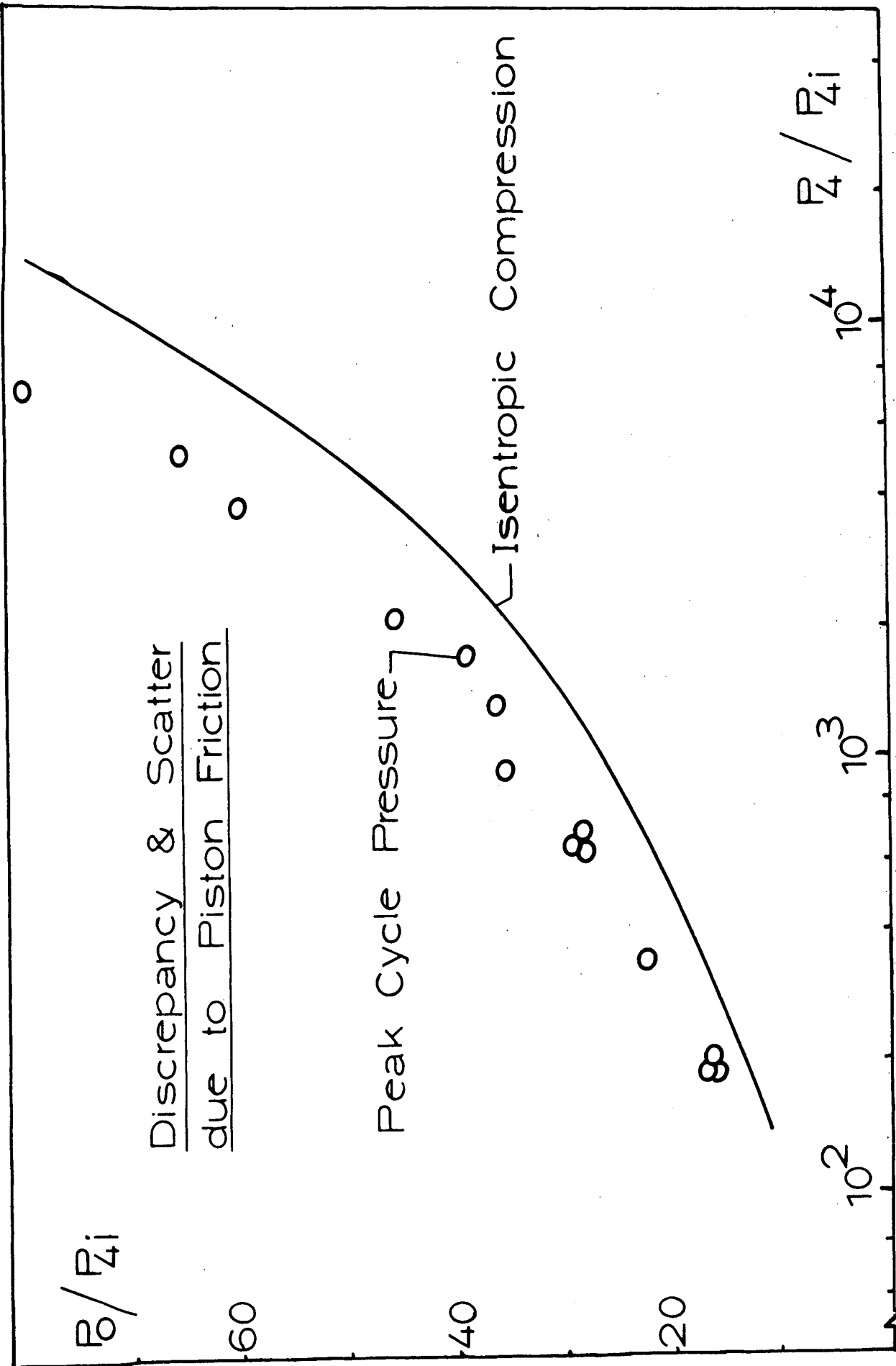

FIG. 9 Compression Process Performance

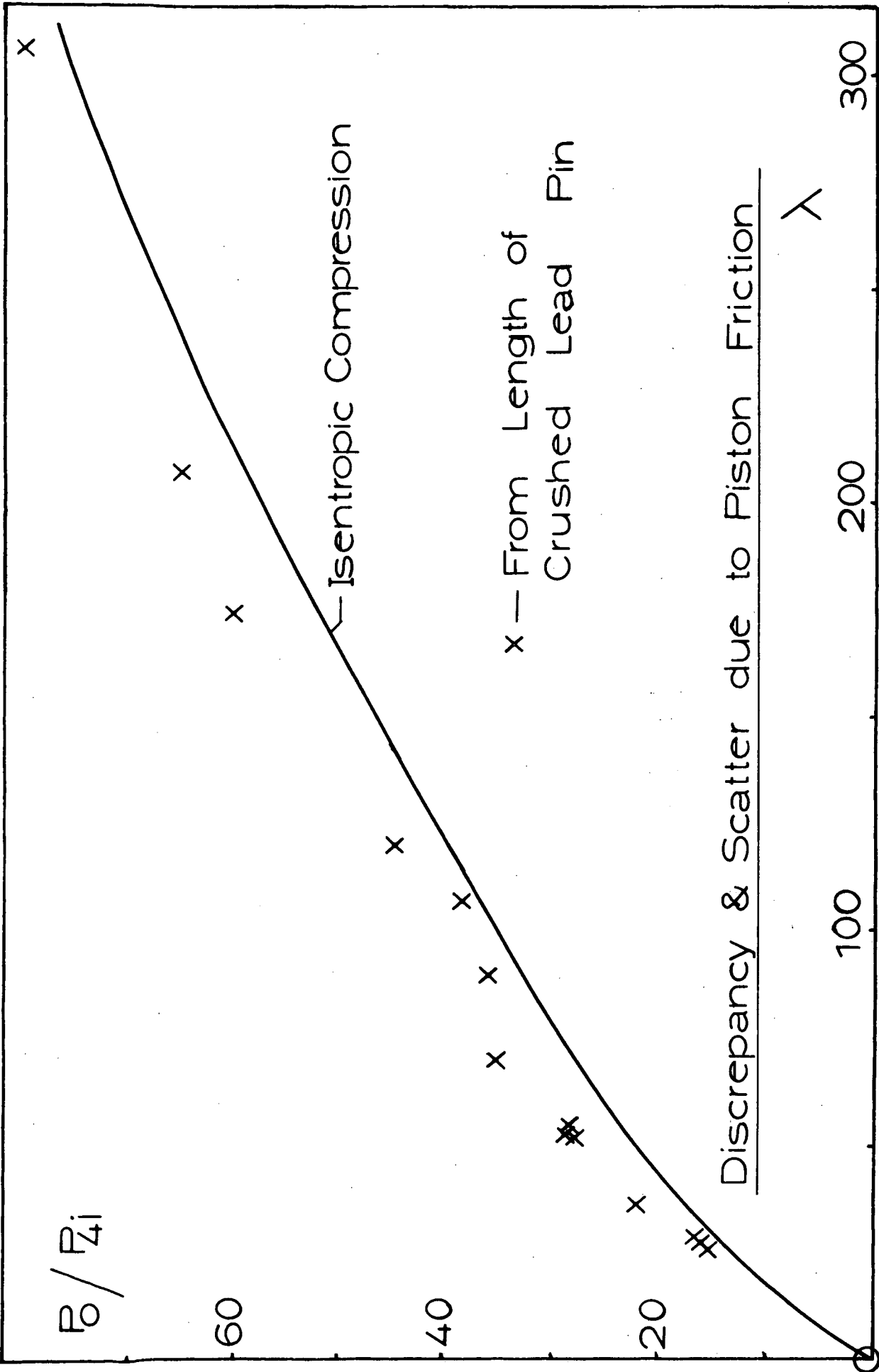

FIG. 10 Compression Process Performance

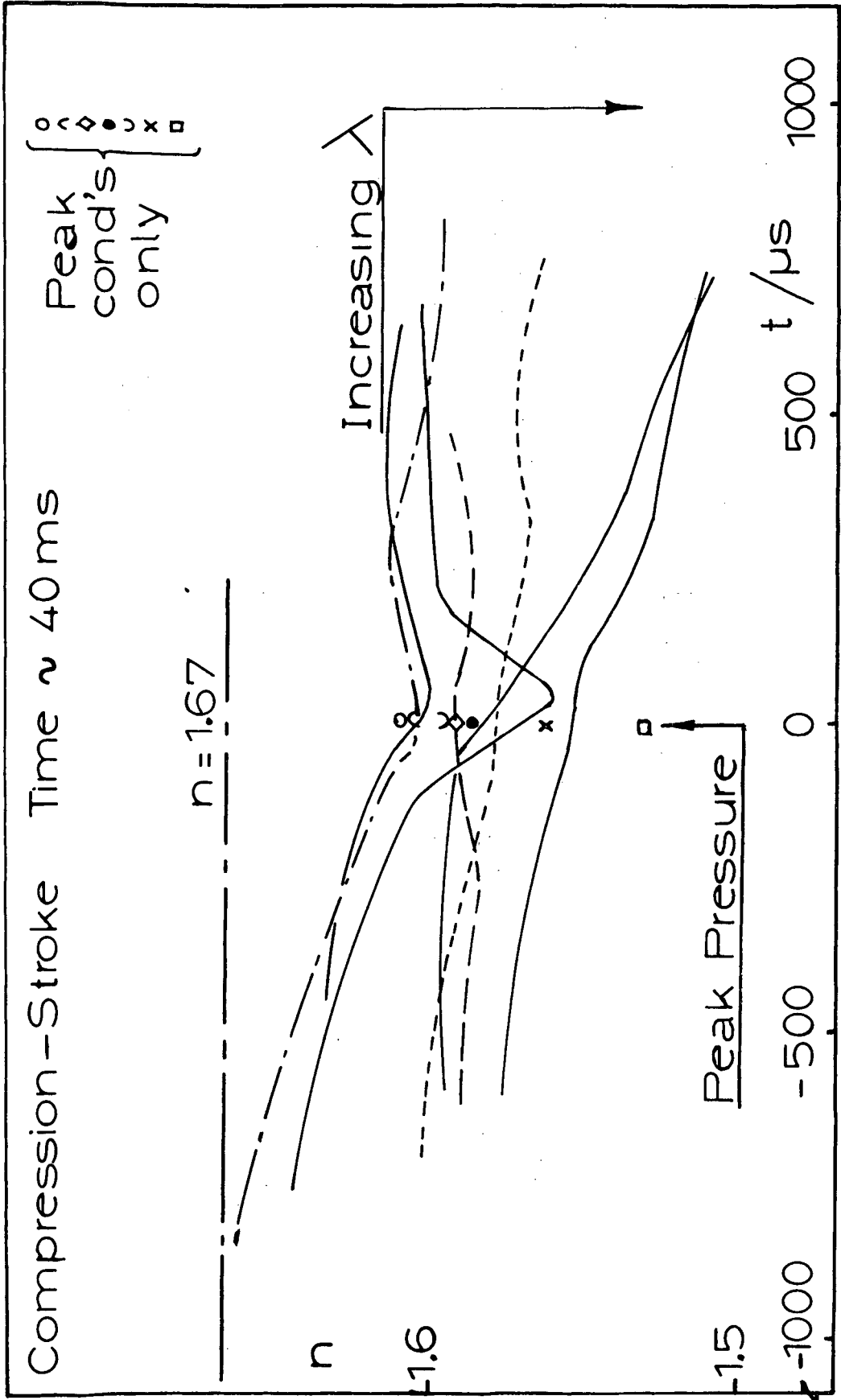

FIG.11 Variation of Polytropic Index n during Final Stage of Compression Stroke

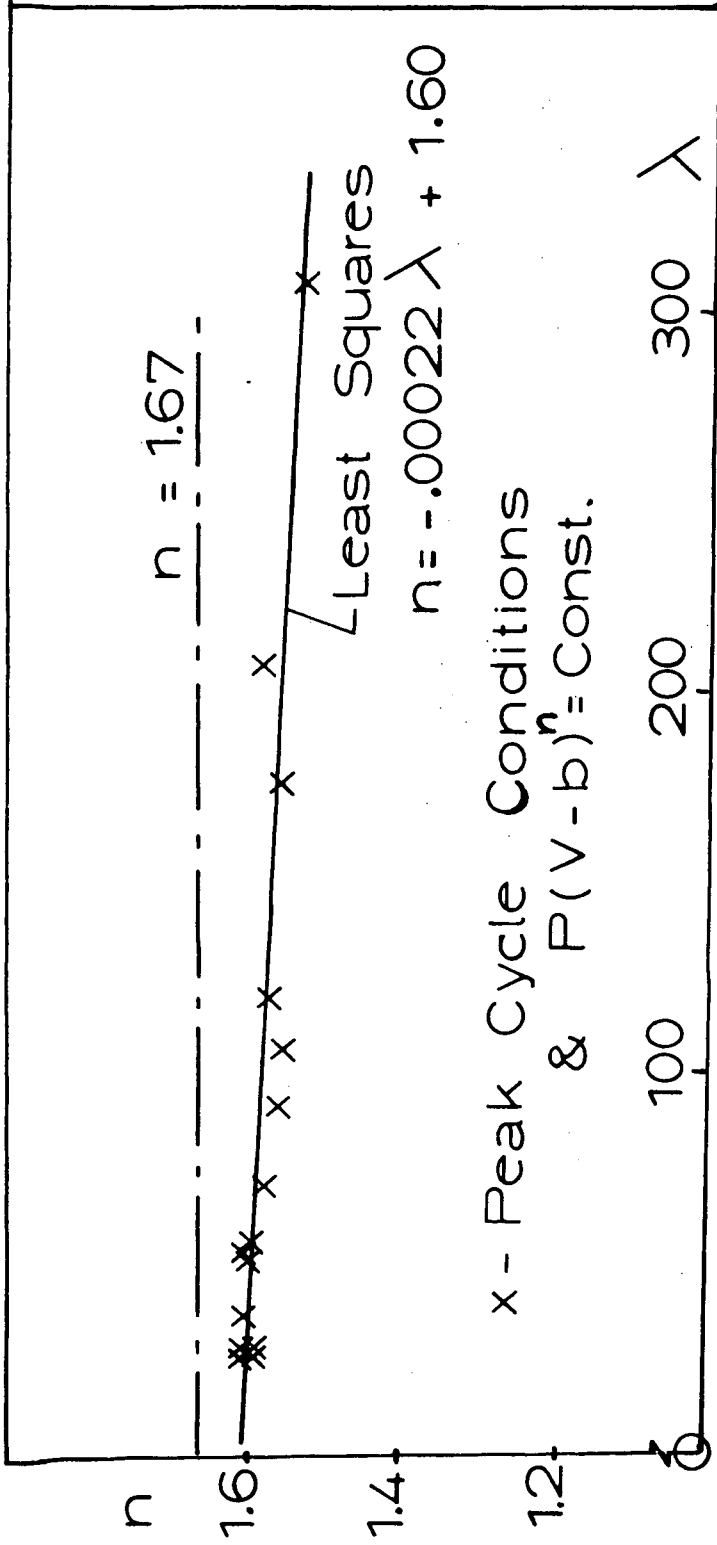

FIG. 12 Correlation of Polytropic Index n with Compression Ratio λ at Peak Conditions

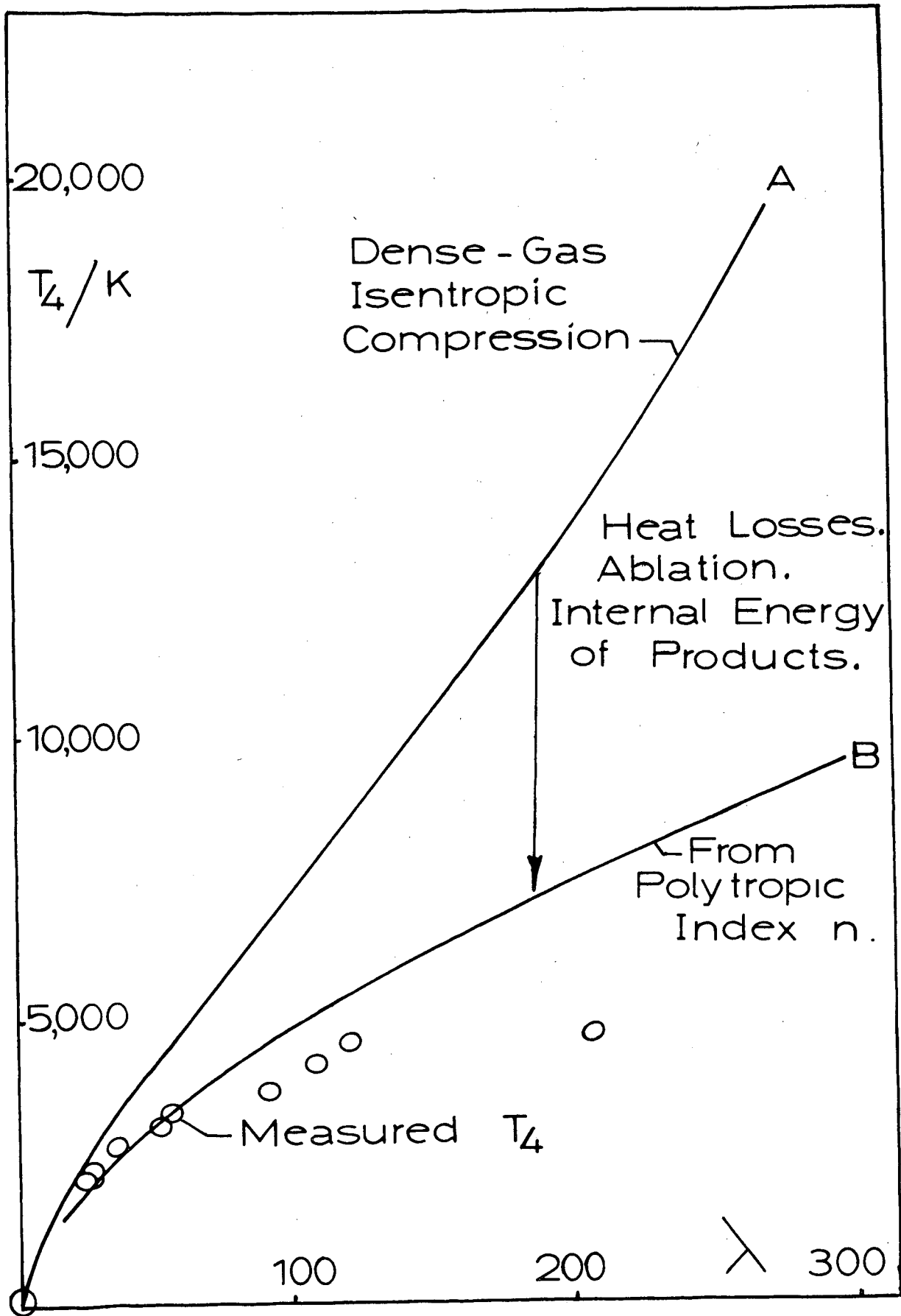

FIG. 13 Temperature Results at Peak Conditions