

N 7 3 2 5 1 4 4

**NASA TECHNICAL
MEMORANDUM**

NASA TM X- 68252

NASA TM X- 68252

**CASE FILE
COPY**

**CYCLIC OXIDATION EVALUATION - APPROACHING
APPLICATION CONDITIONS**

by C. A. Barrett and E. B. Evans
Lewis Research Center
Cleveland, Ohio

**TECHNICAL PAPER presented at
American Ceramic Society
Cincinnati, Ohio, May 2, 1973**

ABSTRACT

This paper is a survey of the cyclic furnace and burner rig oxidation facilities at NASA-Lewis Research Center, a review of selected test results, and an initial interpretation of the data obtained. Cyclic furnace tests are used to conveniently screen alloy oxidation resistance and spall tendency; high velocity tests further indicate dynamic environmental resistance. Alloys which form scales predominantly of Cr_2O_3 /chromite spinel spall much more than those forming $\alpha\text{Al}_2\text{O}_3$ /aluminate spinel scales. Weight changes due to scale spalling were used to estimate alloy depletion/thickness losses.

E-7527

CYCLIC OXIDATION EVALUATION - APPROACHING

APPLICATION CONDITIONS

by C. A. Barrett[‡] and E. B. Evans*

Lewis Research Center
National Aeronautics and Space Administration
Cleveland, Ohio

SUMMARY

This paper is a review of 1000^o-1200^o C cyclic oxidation testing conducted at NASA-Lewis on potential aircraft gas turbine Ni-, Co-, and Fe-base alloys. Furnace and burner rig testing are discussed and the results compared for selected alloys. The alloys fall into two groups depending on their Cr and Al contents. One group forms mainly Cr₂O₃/chromite spinel scale(s); the other forms αAl₂O₃/aluminate spinel scale(s). Spalling on thermal cycling leading to increased metal consumption is associated with the appearance of a chromite spinel. In the case of high velocity burner rig tests this chromite forming tendency is reinforced by Cr₂O₃ vaporization depleting Cr in the alloy. In both types of tests, specific weight change is used as an indirect indicator of metal attack since direct metal loss measurements require destructive analysis. An alternative non-destructive metal loss estimating parameter, based on a tentative mass balance gravimetric approach, shows some potential.

INTRODUCTION

High temperature oxidation resistance is an important factor in selecting alloys for service at elevated temperature in applications such as aircraft gas turbine engines. (Even though most alloys used in the hotter sections are now coated to minimize oxidation attack, inherent oxidation resistance is important in case of coating damage.) The concern here is not with the usual

[‡]Lewis Research Center NASA.

*Prof. Materials Science & Engineering, Formerly of Florida State University Tallahassee, Fla.

isothermal oxidation resistance generally reported in the literature but with the more common type actually found in most service applications - cyclic oxidation. Cyclic oxidation involves repeated heating of the metal component in an operating temperature and environment followed by cooling to an ambient temperature - most often room temperature. In such a process the oxide or scale formed which normally tends to impede further scale buildup (and concomitant metal consumption) at temperature tends to spall or flake off as the sample cools or is heated. The more the oxide spalls, the greater the rate of metal consumption on reoxidation. Sometimes spalling is so severe that grains of metal are removed along with the oxide. A comparison of typical sample specific weight changes as a function of time for isothermal and cyclic oxidation conditions is shown in figure 1.

Cyclic oxidation is difficult to study because there is no agreed upon experimental and interpretive approach such as that generally used in studying isothermal oxidation. In isothermal studies the conventional technique is to measure weight change as a function of time at temperature which is generally a direct measure of oxygen pickup (i. e. , scale formation) as shown by the top plot in figure 1.* In cyclic oxidation the sample is usually weighed after a given number of heating/cooling cycles when the sample is at ambient temperature and a specific weight change versus time curve is generated. But because scale can be lost by spalling a resultant curve such as the bottom plot in figure 1 is typical. Thus, in both types of tests, sample weight change can be a misleading indicator of metal attack unless spalling is so severe that large weight losses roughly rank the alloys. The extent of metal attack cannot be easily derived from simple weight change data. Nevertheless, for cyclic oxidation tests run at most laboratories, sample weight change, particularly weight loss, is used as the prime indicator of cyclic oxidation behavior.

*Sublimation or vaporization of the scale (e.g. , Cr_2O_3 - CrO_3 -) can also occur in isothermal oxidation and, in effect, lead to lower apparent oxygen weight gains. Specific weight change data can be manipulated mathematically to handle this, however (ref. 1).

For most aircraft engine applications, the amount of metal thickness lost, or reduction in the load-carrying area is really the parameter of interest. Metal thickness change can be determined by removing the scale by wire brushing or electrolytic scale stripping in a reducing salt. Then, a direct micrometer measurement may be used to determine the amount of metal consumed. Another possible method of measuring metal consumption is by sectioning, metallographically mounting, and measuring the sample with a micrometer microscope. This last technique, while destructive, is preferable because it also shows the amount of grain boundary and internal oxidation and possible alloy depletion as well. This type of attack may reduce the effective useful metal thickness considerably. But metallographic measurement is difficult, time consuming, and not routinely made in a large test program. A major aid in evaluating the cyclic oxidation resistance of alloys would be the development of a reliable non-destructive method to determine this thickness change. Then the same sample could be reevaluated at intermittent times during test. It would also aid in the interpretation of cyclic oxidation data if a reliable metal consumption parameter could be derived from weight change estimates by some mathematical technique.

The purpose of this report is to describe the cyclic oxidation test approach and test facilities at NASA-Lewis Research Center and to summarize some cyclic oxidation test results for several alloys. In addition, an estimating technique based on weight change will be presented that relates directly to metal consumption and thickness change of the sample.

CYCLIC OXIDATION TESTING TECHNIQUES

Cyclic oxidation testing of turbine engine materials can be looked at as basically a three level process:

- (Level 1) Cyclic, low velocity (static air) furnace tests (simple, easily controlled)
- (Level 2) Cyclic, high velocity (Mach 0.3 - 1.0) burner rig tests (complex, controlled)
- (Level 3) Cyclic engine (or application) tests (very complex, harder to control)

There should be a natural progression for the three levels of tests with 1) being capable of screening a large number of alloys in coupon form for any desired combination of test time, temperature and cycle time. This screening is usually conducted at higher than anticipated use temperature, i. e., an accelerated test. The sample can be weighed intermittently with the degree of specific weight loss (i. e., net sample weight) being used as a rough indicator of cyclic oxidation resistance. If individual sample spall can be collected as well, then the amount of spall can also be used to aid in ranking the alloys. Because there is no standard technique for cyclic testing, the desired characteristics for 1) were met at Lewis Research Center by the development of multi-tube, automatic cyclic test furnaces designed for high capacity, unattended fail-safe operation at temperatures to 1200° C. A schematic representation of this test setup is shown in fig. 2. Each furnace unit can simultaneously test six symmetrically suspended samples in individual ceramic tubes at a given temperature. The heating and cooling cycles for each furnace are controlled by individual reset timers which repeat the same exposure cycles over and over. The samples are automatically raised from and lowered into the furnace pneumatically on each cycle. The cycles are indicated by mechanical and electronic counters. A counter control is used to interrupt the test after any number of pre-set cycles for sample examination and weighing. As the samples leave the furnace to cool, individual spall catchers slide under the individual spall shields to catch as much spall as possible without cross-spall from the other test samples. This collected spall is useful as a general indicator of spalling tendency to rate the alloy as well as for various types of analyses (e. g., X-ray diffraction). Currently there are eight cyclic units operating at NASA-Lewis with typical heating cycles ranging from six minutes to 100 hours and with total test times at temperature to 1000 hours. The specific weight changes for a given alloy usually agree to within 10%-20% for comparable tests in different rigs. Net sample weight measurements derived from the cyclic tests are really the resultant of three basic oxidation processes - scale growth, scale vaporization and scale spalling. Conventional gravimetric isothermal tests can also be used

in parallel to separate out the first two factors by comparing the isothermal results to the cyclic data. Presumably any difference is primary due to spalling in cyclic oxidation.

The second level in the cyclic oxidation test procedure for an alloy is to test the most promising turbine materials in a high temperature open-jet burner rig. Open-jet burner rigs, which burn jet fuel or natural gas, are the simplest facilities that can provide the combustion environment, gas velocities, and thermal gradients similar to those encountered in actual engines. Because the specimens are not enclosed, their temperature distributions can be readily observed. The specimens can be moved out of the burner exhaust for cooling, which allows the burner to operate at steady state, prolonging its life.

Two types of open-jet rigs are in operation at Lewis: large Mach 1 burners with mass flows of 0.5 kilogram per second and smaller burners with mass flows less than 0.07 kilogram per second at velocities close to Mach 0.3. Three large and four small burner rigs are presently available at LeRC. The large rigs can use natural gas or jet fuel; all the smaller rigs use jet fuel.

A large Mach 1 burner rig is shown in figure 3 (ref. 2). A rotating specimen holder supports eight $1'' \times 4'' \times 1/4''$ thick wedge-shaped specimens in front of the burner nozzle, inside clam-shell radiation shields. For cooling, the specimen holder moves downward, positioning the specimens in front of a sonic cooling air stream. The three rigs of this type are used for studies on oxidation, coating, cladding, and thermal fatigue. Two of the rigs have provisions for salt injection for sulfidation studies. It should be noted that only thermal and bending stresses are normally generated in these tests so the axial metallic creep effect is usually not evaluated along with oxidation and thermal fatigue. The smaller less expensive Mach 0.3 rigs (see fig. 4) were developed by Pratt & Whitney so test samples could be made from $1/2''$ diameter rod stock.

It is also possible to run airfoil shaped samples under load (e. g., 20,000 psi) in a burner rig to improve simulation of engine conditions. The entire loading fixture can be pivoted so as to move the specimen in and out of

the burner exhaust allowing the sample to be thermally cycled. The test temperature is usually considered to be that of the leading edge since it is the maximum on the sample and the most likely location for failure due to the combined effects of thermal fatigue, metallic creep and/or oxidation (ref. 3).

The third level in evaluating an alloys cyclic oxidation behavior is to test the alloy as a component(s) in an actual engine. This is an expensive test and when conducted, is usually done by the engine manufacturer.

HIGH TEMPERATURE OXIDATION RESISTANCE

The cyclic oxidation tests at NASA-Lewis are usually conducted in the 1000⁰-1200⁰ C range and primarily include (nickel) Ni-, (cobalt) Co-, and (iron) Fe- base sheet and cast alloys containing Cr (chromium) or Cr and Al (aluminum) for oxidation resistance. For turbine blade applications, for example, the emphasis is on cast Ni- base $\gamma + \gamma'$ (Ni₃Al) strengthened alloys. The protective oxides formed at temperature are generally of two basic types (refs. 1, 2, 4, 5, 6). First, if the alloy contains greater than about 16% Cr with less than 3% Al, Cr₂O₃ and chromite spinel will form and control oxidation behavior. If 3 to 6% Al is present along with a minimum of about 6 - 12% Cr, α Al₂O₃ and aluminate spinel form and control the oxidation process. Without Cr in the alloy, more than 10% Al would be required to form α Al₂O₃ and the alloy would be brittle. Virtually all the alloys of interest fall into either of these two classes with occasional overlap on the border line compositions.

The intrinsic oxidation behavior of these types of scale formers is shown on fig. 5 which indicates the isothermal - ie non-cyclic - parabolic scaling rate constants, k_p , for oxygen pickup over the temperature range of interest. Constants for some typical alloys discussed below in terms of cyclic oxidation are also shown on this plot at 1150⁰ C. If the alloys were used in an application where they are not thermally cycled, or if they did not spall appreciably when cycled, then the alloys with the lowest rate constant would have

the best oxidation resistance. It can be seen in terms of oxygen consumption the $\alpha\text{Al}_2\text{O}_3$ /aluminate spinel with Cr solution forming alloys are somewhat more protective (i. e., with a lower scaling rate constant) than all but the best of the Cr_2O_3 /chromite spinel forming alloys in isothermal or non-spalling cyclic oxidation. It is not clear why the k_p range for Cr_2O_3 /chromite forming alloys is so broad - the highest and lowest can differ by a factor of over 20. There is no obvious reason for this difference though the more complex alloys tend to have the higher rate. An additional complication in the isothermal behavior of the Cr_2O_3 /chromite spinel forming alloys is the increased tendency of Cr_2O_3 to vaporize with increasing temperature. This will increase the overall consumption rate of Cr in the alloy as the scale approaches a limiting thickness. The combination of oxygen pickup and vaporization leads to parabolic kinetics. Generally this parabolic process will not be discernable from the weight change data unless the test times approach 1000 hours in static air or shorter times in a high velocity environment. An exception is TD - NiCr where, because the effective rate constant for Cr_2O_3 is so low* (apparently due to ThO_2 building up in the scale), the vaporization becomes obvious in still air even at times under 100 hours. The main reason for the diminished use of Cr_2O_3 /chromite spinel forming alloys above 1000°C is that vaporization reinforces any spalling tendency when the sample is thermally cycled. This is caused by Cr depletion which favors formation of the chromite spinel rather than Cr_2O_3 alone. NiO forms under these conditions and reacts with Cr_2O_3 to form the chromite spinel. It is mainly the chromite spinel and NiO which are associated with spalling when the sample is cooled.

The $\alpha\text{Al}_2\text{O}_3$ /aluminate spinel forming alloys have no significant vaporization problem even at extreme gas velocities. As the oxidation process depletes the surface in Al, aluminate spinel formation would be favored on the outer surface as the Ni cations diffuse to form NiO which reacts to form the aluminate spinel. It has not been shown that this aluminate spinel leads to severe spalling. The eventual oxidation failure mode of this class of alloys

*See the range of k_p values for TD - NiCr at 1150° in fig. 5 due to the nature of the gravimetric/time curve.

has not been established but it probably occurs when a significant amount of Al in the aluminate spinel is replaced by Cr or excess NiO is formed. On cooling the surface oxide(s) would tend to spall taking the more protective oxides along with them.

The role of reactive elements like Si, Y, Th, La, etc., in these oxidation processes, both in growth and spalling, is not clear. They may delay the formation of the deleterious oxides mentioned above which cause spalling. Whether they have any other effect is debatable, although a finely dispersed oxide like ThO₂ apparently blocks overall scale growth at least in Cr₂O₃ forming alloys.

These features discussed above are consistent with the NASA-Lewis cyclic oxidation test results both in the still air multitube furnaces and in the open-jet burner rigs.

Multisample Still Air Cyclic Furnace Tests

Over 50 Ni-, Co-, and Fe- base alloys have been tested in the Lewis Research Center cyclic multitube furnaces using 100- one hour heating cycles at 1150° C. This is essentially an accelerated oxidation test that allows good discrimination of high temperature oxidation resistance among a wide variety of alloys. Specific weight change at 100 hours (i. e., 100 cycles) along with the accumulated specific weight of the spall permits a reasonably good relative ranking of the alloys to be made. In general these ratings have been verified when the samples are sectioned and the actual thickness changes are measured. This thickness measurement is complicated particularly by grain boundary oxidation, however. Implicit in this type of accelerated test is the assumption that alloys tested for longer times at lower temperatures would show similar oxidation behavior.

The degree of spalling in such tests is classified as follows in terms of the amount of spall observed and collected:

- (1) Negligible 0-0.25 mg/cm²
- (2) Light 0.25-2.00 mg/cm²
- (3) Moderate 2.00-10.00 mg/cm²
- (4) Heavy 10.00-50.00 mg/cm²
- (5) Massive > 50.00 mg/cm²

If this type of spall rating were not used in conjunction with sample weight change data, a large scale buildup with about 1/4 of it spalled could appear as a slightly positive specific weight change - about the same as the best alloy with a thin protective scale and no spall.

Figure 6 compares specific weight change data for 11 of the alloys tested in the multitube cyclic furnaces with data for specimens tested in the Mach 0.3 burner rig, both after 100 one-hour heating cycles at 1150^o C. For comparisons sake they are plotted in decreasing order of oxidation resistance as they were determined in the burner rig using the same specific weight change scale. These values are plotted as bar graphs either as specific weight gain or specific weight loss after 100 cycles. A symmetrical log scale was used starting at 0.1 mg/cm². This is read either as a weight gain or weight loss depending on the direction from the 0.1 mg/cm² origin line. This enables a wide range of specific weight change data to be conveniently summarized on a single plot. The spall rankings for each furnace tested are indicated at the end of each bar graph. In general the alloys that show the greatest weight loss spall the most.

In the furnace tests GE 1541 and TD NiCr are the most oxidation resistant, forming $\alpha\text{Al}_2\text{O}_3$ and Cr_2O_3 respectively with no discernible spall. The slight weight loss for the TD NiCr is due to vaporization of the Cr_2O_3 . B 1900 is next with chromite spinel in the aluminate associated with the moderate spall. The Ni base sheet superalloys, HAS X and IN 601, with high Cr levels (22-23 Cr) favor Cr_2O_3 over the chromite spinel for a longer time than HAS C 276 with 16 Cr which oxidizes at a high rate and spalls massively. HA 188 and L605 are Co base analogs of these Ni base alloys with high Cr but are heavier spallers. This appears due to more CoO formation which spalls heavily itself and leads to more spall prone chromite spinel. La appears to improve the spall resistance of the HA 188, however. The other cast alloys (IN 100, X 40 and WI 52) have poor cyclic oxidation resistance with heavy to massive oxide spalling again associated with chromite spinel formation.

HIGH VELOCITY BURNER RIG TESTS

A comparison with cyclic furnace results can be made for open-jet Mach 0.3 burner rig tests which are also of a cyclic nature. Those reported here involve 100, one hour heating cycles at 1150° C using forced air cooling. The cooling time between heating cycles was three minutes except that once every 20 hours, the sample was weighed. The wedged shaped 3" long samples shown modeled in fig. 4 are machined from 1/2" diameter bar stock. For specific weight change estimates the exposure area is estimated as 13.5 cm² for each sample. Since there is no way to collect the spall, this specific weight change along with appearance, is the only non-destructive indication of cyclic oxidation resistance. In figure 6, the Mach 0.3 rig oxidation data are plotted on bar graphs for the same eleven alloys. Along side, the furnace test data are also plotted for comparison. In general the results are as expected when the environment involves high velocity air. The Cr₂O₃ which normally forms almost exclusively on TD NiCr vaporizes at a high rate in high velocity air. The resulting Cr depletion rapidly leads to the formation of NiO and chromite spinel which spalls on cooling giving a large specific weight loss. Under these conditions TD NiCr behaves about the same as a typical Ni- base sheet superalloy. Considering that in addition to the high velocity hot air jet the overall size and shape of the Mach 0.3 burner rig samples are different and that they are air blast cooled, the results from both types of test are similar.

It might be expected that the burner rig tests would consistently show much greater weight loss than comparable static air tests. However, this is not always true. There are a few alloys for which the furnace tests show a greater weight loss (e.g., IN 100, HAS C 276). One possible explanation for this unexpected reversal is that in a static test the scale may reach a greater thickness before it spalls to nearly bare metal while in the burner rig it may only partially spall at a thinner critical thickness. In any case, results from both of these cyclic tests differ drastically from isothermal tests. The exceptions are the α -Al₂O₃/aluminate forming alloys (e.g., GE 1541) all of

which seem to agree to about a factor of two regardless of whether they are tested isothermally or cyclically. The cyclic burner rig tests differ drastically from the cyclic furnace still air tests for an alloy containing high Cr but which does not spall significantly (e.g., TD NiCr). This is due to effective exclusive formation of Cr_2O_3 with no significant chromite spinel in the furnace tests.

MASS BALANCE APPROACH

As was mentioned above, the most direct measure of total oxidation (including oxide growth, -vaporization, and -spalling) is thickness change of the metal sample underneath the retained scale. Figure 7 shows a comparison of metal recession measurements for seven of the alloys presented in figure 6. These are shown as bar graphs of thickness change of coupon samples of various sheet alloys after 100 hours at 1150°C in both isothermal and cyclic furnace tests. It should be noted that this thickness change is defined as including both metal loss and grain boundary oxidation penetration. The trends are in general agreement with the specific weight change measurements from furnace tests discussed above. This figure also points out the increased depth of attack when a metal is converted to a spall prone oxide (i.e., the chromite spinel formers). The extreme case is the Ni-base superalloy HAS C 276 which has close to 40 times the cyclic attack ($\sim 1200\text{ um}$) compared to isothermal attack (30 um). Obviously from both a mechanistic and design point of view, the thickness change is a more meaningful value than just a resultant specific weight change. If these thickness change values could be determined as a function of time either non-destructively or from the weight change data, then more meaningful kinetic and design data could be derived.

A non-destructive (NDE) approach to measure metal thickness under a retained scale is being investigated at NASA-Lewis but is in an early stage of evaluation. Of the various possible methods (radiographic, ultrasonic, etc.) one rather different approach involves a microwave technique. A unit

was developed for NASA at the University of Wisconsin which can measure bare metal thickness with an accuracy of one micron - about the same as the best metallographic procedure. The effect of the surface oxide on the microwave measurement is still under study, however. Another NDE approach is to estimate oxide thickness (e.g., by beta ray back scatter) and subtract that from the total specimen thickness to achieve a metal thickness estimate. This method is also under evaluation. Another route to an estimate of metal consumption during oxidation is to derive this value from the gravimetric data in terms of a mass balance.

The specific weight change of the sample, ΔW , at any time can be expressed as follows in mgs/cm^2 (ref. 1):

$$\Delta W = \frac{1}{b_r} W_r - \frac{a_v}{b_v} W_v - \frac{a_s}{b_s} W_s \quad (1)$$

where W_r , W_v and W_s are the specific weights of the oxides in mgs/cm^2 of the retained (unspalled), vaporized, and spalled scales respectively. In order to balance the equation, the a and b values are stoichiometric oxide composition factors again referring to the retained, vaporized or spalled oxides respectively. Value a is the ratio of atomic weight(s) of metal to oxygen in the oxide and value b is the ratio of molecular weight of oxide to oxygen in the oxide. For example, for Cr_2O_3 $a = 2.17$ and $b = 3.17$.* For Al_2O_3 $a = 1.12$ and $b = 2.12$. It follows that $a + 1 = b$. These stoichiometric factors can be calculated for a range of oxides from their atomic weights and assigned to the various scales detected from X-ray diffraction data.

The specific weight of the metal converted to total oxide (including retained, vaporized or spalled oxide) in mg/cm^2 is:

$$W_m = \frac{a_r}{b_r} W_r + \frac{a_v}{b_v} W_v + \frac{a_s}{b_s} W_s \quad (2)$$

* At wt of Cr is 52 and O is 16. $a = 2 \times 52/3 \times 16 = 2.17$ and $b = 2 \times 52 + 3 \times 16/3 \times 16 = 3.17$.

If the average density of the metal converted to oxide can be estimated, then an effective thickness change from one side in μm can be estimated:

$$\Delta t = \frac{W_m}{\rho_{\text{met, avg}}} \quad (3)$$

(Multiply W_m by 10 to convert Δt to microns.) Where ρ is the density of metal converted to oxide, gms/cm^3 . Equations (1) and (2) can be added and since $a + 1 = b$

$$W_m = W_r - \Delta W \quad (4)$$

Thus various experimental approaches are dictated by the choice of equations to arrive at W_m . In the still air cyclic tests since the spall is collected, W_s and its constants can be estimated. W_v for Cr_2O_3 is relatively small with known a_v and b_v values and ΔW is the parameter measured directly by intermittent sample weighing. This leaves W_r as the major unknown since a_r and b_r can be determined by in situ X-ray diffraction identification of the retained scale. W_r is now the only unknown in Eq. (1) and can be solved for directly. The major uncertainty in this determination is accurately estimating W_s . Not all the spall can be collected and this required the true spall weight to be calculated from the observed spall weight based on calibration runs.

An illustrative calculation is as follows for alloy HA 188. From the average of two separate cyclic furnace runs the pertinent values can be substituted in Eq. (1)) as follows where the unknown is the amount of retained scale:

$$-17.48 = \frac{2.55}{3.55} W_r - \frac{2.17}{3.17} \times 0.81 - \frac{3.11}{4.11} \times 42.88 \quad (1)$$

Solving for W_r gives a value of 15.02 mg/cm^2 . Using Eq. (2) to solve for W_m :

$$W_m = \frac{2.55}{3.55} \times 15.02 + \frac{2.17}{3.17} \times 0.81 + \frac{3.11}{4.11} \times 42.88$$

$$= 10.78 + 0.55 + 21.16 = 32.49$$

Using this value of total W_m and from the X-ray data as estimated average density of all the metals converted to oxide of 8.22 gms/cm^3 Eq. (3) can be used to calculate the equivalent thickness change, Δt , in microns as follows (for attack from one side):

$$\Delta t = 10 \times \frac{32.49}{8.22} = 40$$

The factor of 10 is the net conversion factor involved in going from mgs to gms to give the thickness change in cms and then converting the value to microns.

In burner rig tests the spall cannot be collected so W_s cannot be estimated. W_v is also difficult to evaluate because of the high velocity gas impingement. For this reason Eq. (4) shows more promise for estimating W_m with the main uncertainty being W_r . This focuses the need to measure the amount of retained scale in burner rig tests so as to allow W_m to be determined. As previously mentioned non-destructive technique such as B-ray back reflection are currently being investigated at NASA-Lewis to attempt to measure W_r .

Figure 8 shows the estimated thickness change using the mass balance approach (Eqs. (1) through (4)) and the actual measured change for both the isothermally and cyclically tested samples as were plotted on figure 7. Figure 8 also includes similar data on other sheet alloys tested at NASA-Lewis. The solid 45° line would represent a perfect fit for the test points.

The correlation seems reasonably good with the major uncertainty being samples that show grain boundary oxidation. Multiplying the estimated Δt_{wm} values by a factor of three would include most measured values including grain boundary oxidation. This approach, if proven successful in further evaluations, should permit any type of oxidation attack to be rated on a common basis suitable for design purposes regardless of how the alloy is tested.

It should be pointed out the key practical question in oxidation is how much the material is actually damaged by the overall attack in terms of its eventual service life. Damage estimates by post oxidation exposure tensile tests seem to be a reasonable next step in life prediction for various service applications.

SUMMARY OF RESULTS

This paper surveys the high temperature oxidation test approach and test facilities at NASA-Lewis Research Center. It provides a review of oxidation test results for various alloys in the 1000 to 1200^o C range and it presents a tentative estimation technique for relating weight change to metal loss.

Initial screening of an alloy's cyclic oxidation resistance with emphasis on scale spalling can be rapidly and conveniently conducted in multitube automatic cycling furnaces developed at NASA-Lewis. Burner rig tests, the next level of cyclic oxidation testing at this laboratory involve special sample shapes, high impingement velocities and rapid cooling. The prime indicator of oxidation attack in both cases is sample weight change. The pertinent results and conclusions for Ni-, Co-, and Fe- base alloys can be summarized as follows:

(1) In the 1000-1200^o C range alloys which contain upwards of 16% Cr and 3% Al or less tend to form spall prone Cr₂O₃/chromite spinel scales. The spalling tendency increases as the chromite spinel content increases. Alloys with 4 to 6% Al along with at least 6% Cr form α Al₂O₃/aluminate spinel scales which are highly oxidation resistant and have little tendency

spall. The Cr present, although needed to allow the formation of $\alpha\text{Al}_2\text{O}_3$ in the 4 to 6% Al range, eventually allows a chromite spinel to replace the aluminate spinel. This leads to scale spalling upon thermal cycling.

(2) The burner rig tests show that the chromite spinel spalling failure process can be accelerated by high gas velocity impingement on alloys forming mainly Cr_2O_3 . The enhanced vaporization of the Cr_2O_3 scale as CrO_3 causes enhanced Cr depletion in the alloy. This increases the rate of chromite spinel buildup which can lead to catastrophic spalling on repeated cycling.

(3) The damage due to cyclic oxidation affecting service life is more directly measured by metal thickness change and grain boundary penetration than by weight change. This change is usually measured metallographically but is destructive and terminates the test for a given sample. A tentative mass balance technique was developed which estimates thickness change from weight change data. This technique appears promising.

REFERENCES

1. C. A. Barrett, and C. E. Lowell, "Comparison of Cyclic and Isothermal Oxidation Behavior of 25 High-Temperature Sheet Alloys at 1150°C ." To be published.
2. J. R. Johnston, and R. L. Ashbrook, "Oxidation and Thermal Fatigue Cracking Nickel- and Cobalt-Base Alloys in a High-Velocity Gas Stream," NASA TN D-5376, 1969.
3. D. A. Spera, and S. J. Grisaffe, "Life Prediction of Turbine Components: On-Going Studies at Lewis Research Center," NASA TM X-2664, 1973.
4. R. G. Garlick, and C. E. Lowell, Alloy Composition Effects on Oxidation Products of VIA, B1900, 713C, and 738X-A High-Temperature Diffractometer Study, " NASA TM X-2796, 1973.
5. C. A. Barrett, G. Santoro, and C. E. Lowell, "Isothermal and Cyclic Study of NASA TRW VIA, B1900, & 13C, and 738X at 1000° and 1100°C ," Proposed NASA Technical Note.
6. C. E. Lowell, "Cyclic and Isothermal Oxidation Behavior at 1100° and 1200°C of Nickel - 20-Percent-Chromium, Nickel - 20-Percent-Chromium - 3-Percent-Manganese, Nickel - 20-Percent-Chromium - 3-Percent-Silicon, and Nickel - 40-Percent-Chromium Alloys," NASA TN D-7267, 1973.

TABLE I. - NOMINAL CHEMICAL COMPOSITION OF
ALLOYS DISCUSSED IN THIS REPORT

Alloy	Ni	Fe	Co	Cr	Al	Ti	W	Mo	Cb	Ta	Si	Other
GE 1541		Bal		15	4							1Y
IN 601	Bal	13		23	1.5						0.5	0.04 C 0.4 Mn
B 1900	Bal		8	10	6	1		6		4.3		0.11 C 0.015 B 0.07 Zr
IN 100	Bal		15	9.5	5.5	4.5		3				0.17 C 0.015 B 0.05 Zr 1V
HAS X	Bal	18.5	2	22				9				
X 40	10.5		Bal	26			8					0.5 C
TD NiCr	Bal			20								2 ThO ₂
HAS C 276	Bal	5	1	16			3.5	16				
HA 188		1.5	Bal	22			14.5					0.1 C 0.075 La
WI 52		1.8	Bal	21			11			2		0.45 C
L 605		1.5	Bal	20			15					0.08 C 1.5 Mn

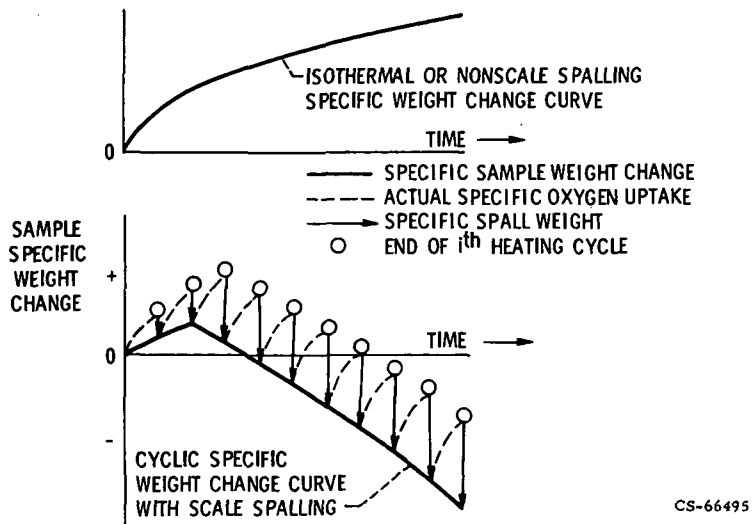

Figure 1 - Schematic representation comparing an isothermal or non-scale spalling cyclic oxidation specific weight change curve with a similar curve with significant scale spalling due to thermal cycling.

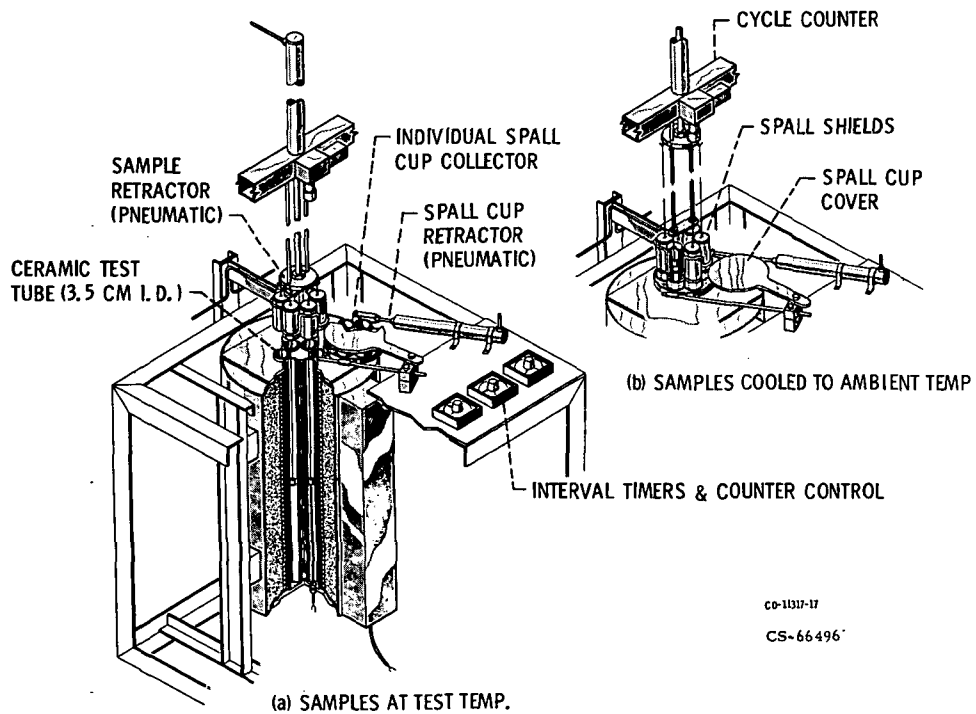

Figure 2 - Multitube automatic high temperature cyclic oxidation test rig.

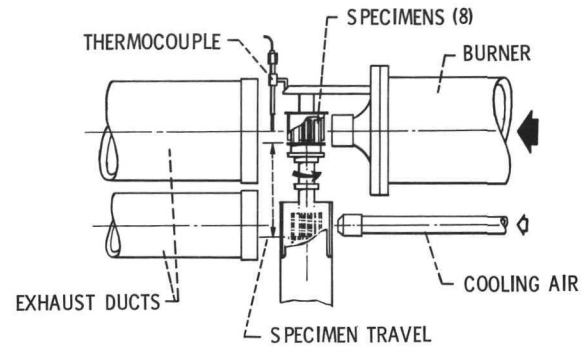
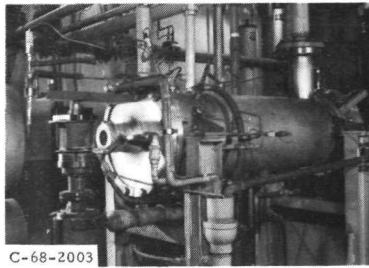

Figure 3. - High-gas-velocity oxidation apparatus. Mach 1.0 test rig.

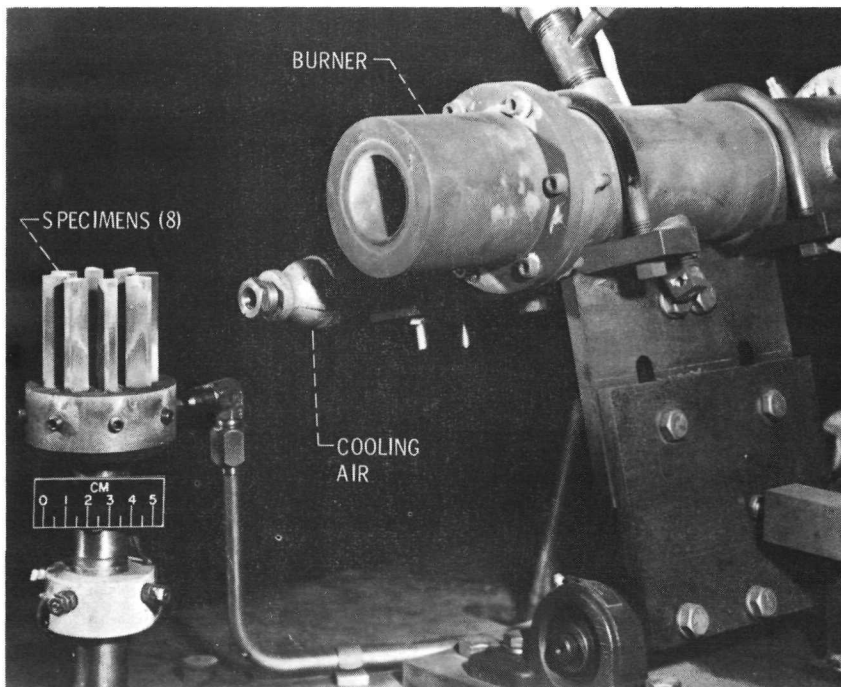

Figure 4. - High-gas-velocity oxidation apparatus. Mach 0.3 test rig.

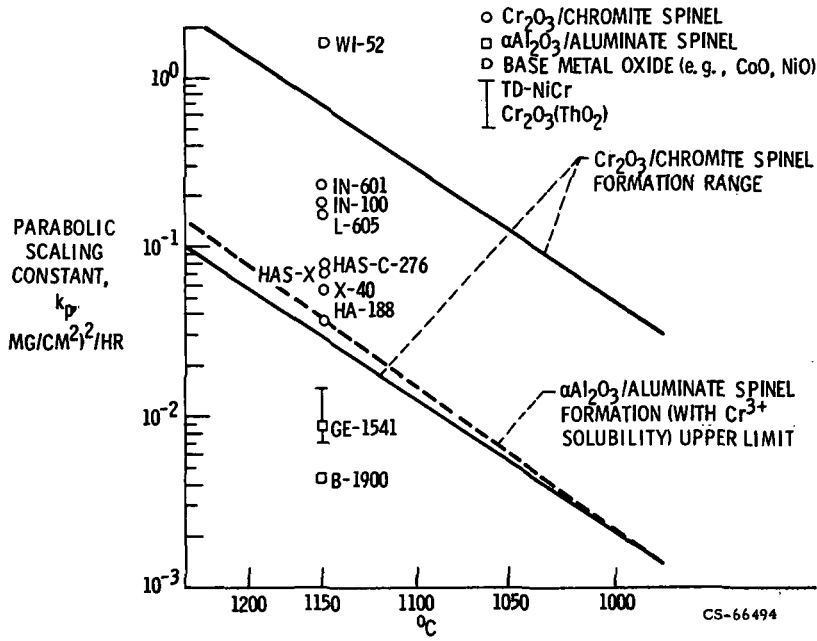

Figure 5. - Parabolic oxidation scaling constants as a function of absolute exposure temperature in the 1000 to 1200° C range for various Ni-, Co- and Fe-base alloys for isothermal tests.

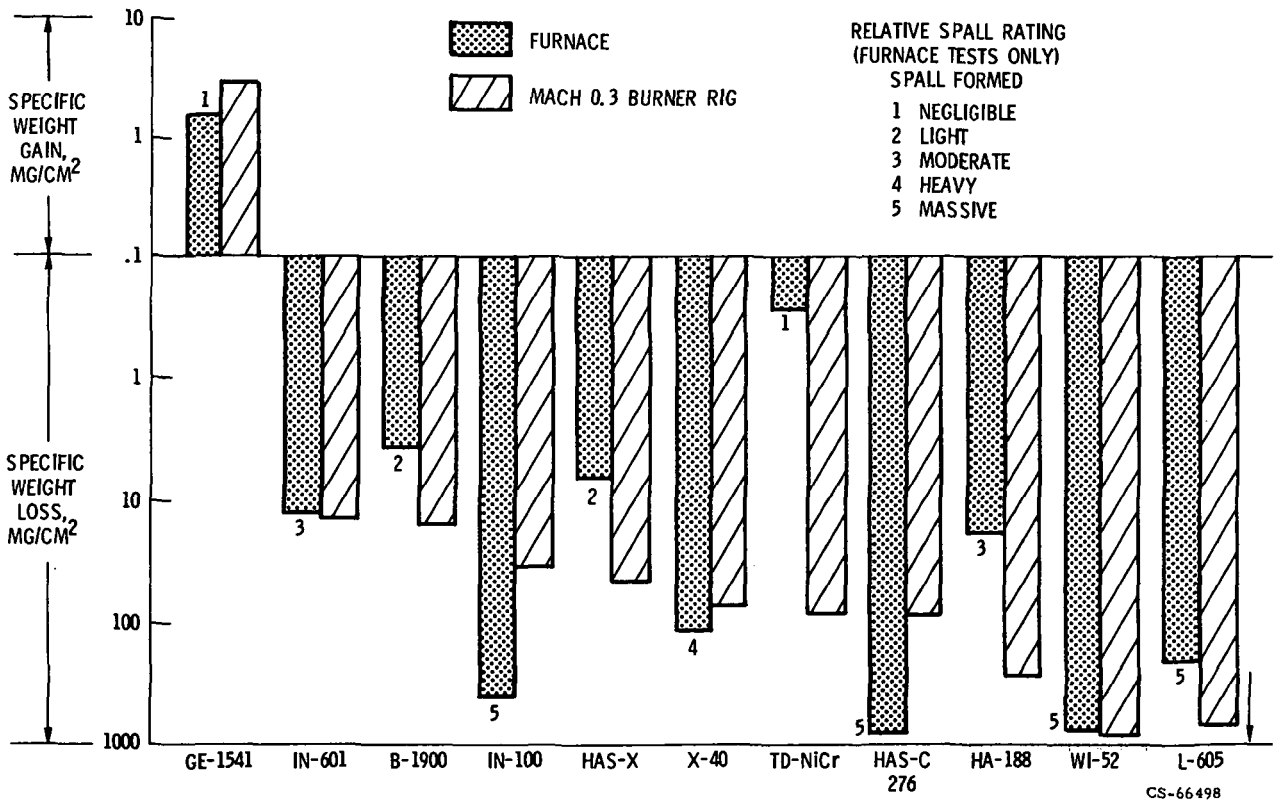

Figure 6. - Comparison of furnace and Mach 0.3 burner rig cyclic oxidation behavior of Halloys tested at 1150° C for 100 one-hour heating cycles.

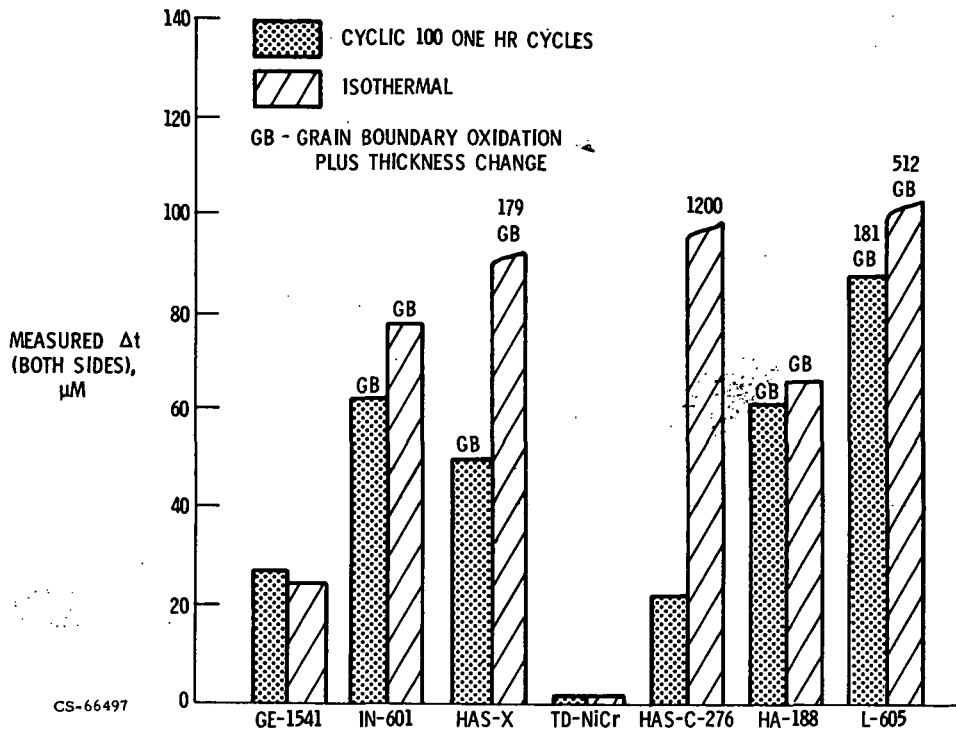

Figure 7. - Comparison of measured thickness change (Δt -both sides) 100 hour isothermal and 100-one hour cycles 1150°C in still air for selected sheet alloys (values include any significant grain boundary oxidation).

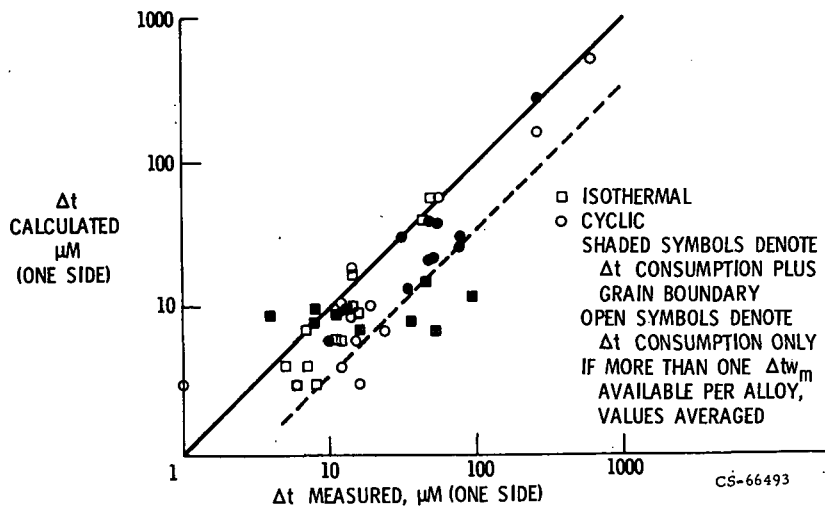

Figure 8. - Comparison of alloy thickness change calculated from a gravimetric mass balance approach to actual measured thickness change for alloy oxidation in still air at 1150°C for 100 hour isothermal or 100-one hour cyclic exposures.