

**NASA TECHNICAL
MEMORANDUM**

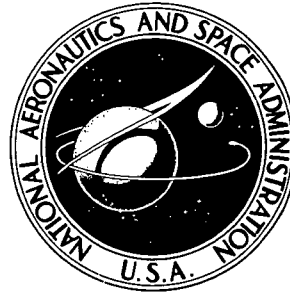

NASA TM X-2903

NASA TM X-2903

**PERFORMANCE OF TRANSONIC FAN STAGE
WITH WEIGHT FLOW PER UNIT ANNULUS AREA
OF 208 KILOGRAMS PER SECOND PER
SQUARE METER (42.6 (LB/SEC)/FT²)**

by Donald C. Urasek, George Kovich, and Royce D. Moore

Lewis Research Center

Cleveland, Ohio 44135

1. Report No. NASA TM X-2903	2. Government Accession No.	3. Recipient's Catalog No.	
4. Title and Subtitle PERFORMANCE OF TRANSONIC FAN STAGE WITH WEIGHT FLOW PER UNIT ANNULUS AREA OF 208 KILOGRAMS PER SECOND PER SQUARE METER (42.6 (lb/sec)/ft ²)		5. Report Date November 1973	6. Performing Organization Code
		8. Performing Organization Report No. E-7229	10. Work Unit No. 501-24
7. Author(s) Donald C. Urasek, George Kovich, and Royce D. Moore		11. Contract or Grant No.	
9. Performing Organization Name and Address Lewis Research Center National Aeronautics and Space Administration Cleveland, Ohio 44135		13. Type of Report and Period Covered Technical Memorandum	
		14. Sponsoring Agency Code	
12. Sponsoring Agency Name and Address National Aeronautics and Space Administration Washington, D. C. 20546		15. Supplementary Notes	
16. Abstract Performance was obtained for a 50-cm-diameter compressor designed for a high weight flow per unit annulus area of 208 (kg/sec)/m ² . Peak efficiency values of 0.83 and 0.79 were obtained for the rotor and stage, respectively. The stall margin for the stage was 23 percent, based on equivalent weight flow and total-pressure ratio at peak efficiency and stall.			
17. Key Words (Suggested by Author(s)) Turbomachinery Turbofans Compressors Transonic compressors Axial flow compressors		18. Distribution Statement Unclassified - unlimited	
19. Security Classif. (of this report) Unclassified	20. Security Classif. (of this page) Unclassified	21. No. of Pages 97	22. Price* Domestic, \$3.75 Foreign, \$6.25

PERFORMANCE OF TRANSONIC FAN STAGE WITH WEIGHT FLOW PER
UNIT ANNULUS AREA OF 208 KILOGRAMS PER SECOND
PER SQUARE METER (42.6 (LB/SEC)/FT²)

by Donald C. Urasek, George Kovich, and Royce D. Moore

Lewis Research Center

SUMMARY

Aerodynamic performance was obtained for a 50-centimeter-diameter single-stage axial-flow transonic compressor designed for a high weight flow per unit annulus area of 208 kilograms per second per square meter at a rotor-blade tip speed of 425 meters per second. Performance data were taken over the stable operating flow range of the stage at equivalent rotative speeds from 50 to 100 percent of design speed.

Peak efficiency for both rotor and stage occurred at an equivalent weight flow of 30.2 kilograms per second as compared with the design value of 31.0. Peak efficiency values of 0.83 and 0.79 were obtained for the rotor and stage, respectively.

The stall margin for the stage was 23 percent, based on equivalent weight flow and total-pressure ratio at peak efficiency and stall.

Rotor blade-element performance indicated that the outer 50 percent of the blade was choked at design weight flow and that high rotor losses occurred in the region between the blade damper and the hub.

Stator losses at the overall equivalent weight flow corresponding to stage peak efficiency are approximately equal to design values across the entire blade span except in the regions of the hub and behind the rotor damper.

INTRODUCTION

The NASA Lewis Research Center is engaged in a research program on axial-flow fans and compressors for advanced air-breathing engines. The program is directed primarily toward reducing the size and weight of the fans and compressors while maintaining a high level of performance.

In support of this program experimental studies are being conducted to investigate the effect of weight flow per unit annulus area on efficiency and stall margin. A series of three transonic compressor stages were designed for weight flows per unit annulus area values of 178, 198, and 208 kilograms per second per square meter. All three stages have a design pressure ratio of 1.57, and all three stages use the same flow path geometry. Two of the stages in this series, having design weight flow per unit annulus area of 178 and 198 kilograms per second per square meter, were tested earlier, and the results are presented in references 1 and 2.

This report presents the aerodynamic design and experimental performance of a single-stage axial-flow transonic compressor designed for a weight flow per unit annulus area of 208 kilograms per second per square meter. This stage is designated "stage 17-12" (rotor 17 - stator 12). The overall performance of both rotor and stage and the blade-element performance of both rotor and stator are presented. The data are presented over the stage stable operating flow range at rotative speeds from 50 to 100 percent of design speed. The design rotor-blade tip speed is 425 meters per second. Surveys of the flow conditions were taken at 11 radial positions. The tests were conducted in the single-stage compressor facility at Lewis.

AERODYNAMIC DESIGN

Three computer programs were used in the design of this compressor stage: the streamline analysis program, the blade geometry program, and the blade coordinate program. These programs are described in detail in references 3 and 4; only a brief description of each is presented in this report.

The streamline analysis program was used to calculate the flow field parameters at several axial locations, including planes approximating the blade leading and trailing edges for both the rotor and stator. The weight flow, rotative speed, flow path geometry, and radial distributions of total pressure and temperature are inputs in this program. The program accounts for both streamline curvature and entropy gradients; boundary-layer blockage factors are also included.

The distributions of velocity, total pressure, and total temperature calculated in the streamline analysis program are used in the blade geometry program to compute blade geometry parameters. The total loss for this rotor blade was based on the experimental rotor loss data presented in reference 3. The profile loss was then estimated by subtracting a calculated shock loss from the total loss. The shock loss calculation was based on the method presented in reference 5. Because of the stringent design requirements for this rotor, the forward portion of the transonic compressor blade over most of the blade span had considerable camber, resulting in high shock loss values. Thus,

the design profile losses over most of the blade span so computed were unrealistically small. Profile loss for the stator was based on the data presented in reference 6.

The blade geometry parameters are used in the blade coordinate program (ref. 7) to compute blade elements on conical surfaces passing through the blade. In this program the blade elements are then stacked on a line passing through their centers of gravity, and Cartesian blade coordinates, which are used directly in fabrication, are computed.

The overall design parameters for stage 17-12 are listed in table I, and the flow path is shown in figure 1. This stage was designed for an overall pressure ratio of 1.57 at a weight flow of 31.0 kilograms per second (208 (kg/sec)/m^2 of annulus area). The design tip speed was 425 meters per second. The rotor and stator were designed for a tip solidity of 1.3. The rotor had 43 blades with an aspect ratio of 2.4, and the stator had 48 blades with an aspect ratio of 2.3.

The blade-element design parameters for rotor 17 are presented in table II. This rotor was designed for a radially constant total pressure ratio of 1.60. The stator blade-element design parameters are given in table III. The blade geometry is presented in table IV for rotor 17 and in table V for stator 12. Both the rotor and stator have multiple-circular-arc blade shapes.

The symbols and equations are given in appendixes A and B. The abbreviations and units used for the tabular data are presented in appendix C.

APPARATUS AND PROCEDURE

Compressor Test Facility

The compressor stage was tested in the Lewis single-stage compressor facility (described in detail in ref. 4). A schematic diagram of the facility is shown in figure 2. Atmospheric air enters the test facility through an inlet located on the roof of the building and flows through the flow measuring orifice and into the plenum chamber upstream of the test stage. The air then passes through the experimental compressor stage into the collector and is exhausted to the atmosphere.

Test Stage

Photographs of the rotor and stator are shown in figures 3 and 4. The rotor blades have vibration dampers located at about 50 percent span. The maximum thickness of the damper is 0.215 centimeter. The nonrotating radial tip clearance of the rotor was a

nominal 0.05 centimeter at ambient conditions. The axial spacing between the rotor hub trailing edge and the stator hub leading edge was 2.80 centimeters.

Instrumentation

The compressor weight flow was determined from measurements on a calibrated thin-plate orifice that was 38.9 centimeters in diameter. The temperature at the orifice was determined from an average of two Chromel/Alumel thermocouples. Orifices pressures were measured by calibrated transducers.

Radial surveys of the flow were made upstream of the rotor, between the rotor and stator, and downstream of the stator. Photographs of the survey probes are shown in figure 5. Total pressure, total temperature, and flow angle were measured with the combination probe (fig. 5(a)), and the static pressure was measured with an 8° C-shaped wedge probe (fig. 5(b)). Each probe was positioned with a null-balancing, stream-directional sensitive control system that automatically aligned the probe to the direction of flow. The thermocouple material was iron/constantan. The probes were calibrated in an air tunnel. A combination probe and wedge static probe were used at each of the three measuring stations.

Inner- and outer-wall static-pressure taps were located at the same axial stations as the survey probes. The circumferential locations of both types of survey probes along with inner- and outer-wall static pressure taps are shown in figure 6. The combination probes downstream of the stator (station 3) were circumferentially traversed one stator blade passage (7.5°) counterclockwise from the nominal values shown.

An electronic speed counter, in conjunction with a magnetic pickup, was used to measure rotative speed (in rpm).

The estimated errors of the data based on inherent accuracies of the instrumentation and recording system are as follows:

Flow rate, kg/sec	±0.3
Rotative speed, rpm	±30
Flow angle, deg	±1
Temperature, K	±0.6
Rotor inlet total pressure, N/cm ²	±0.01
Rotor outlet total pressure, N/cm ²	±0.10
Stator outlet total pressure, N/cm ²	±0.10
Rotor inlet static pressure, N/cm ²	±0.04
Rotor outlet static pressure, N/cm ²	±0.07
Stator outlet static pressure, N/cm ²	±0.07

At each measuring station the integrated weight flow is computed based on the radial survey data. An indication of the consistency of the data can be observed by comparing integrated weight flows at each of the measuring stations to the orifice weight flow in table VI.

Test Procedure

The stage survey data were taken over a range of weight flows from maximum flow to the near-stall conditions. At 70, 90, and 100 percent of design speed, radial surveys were taken over the whole flow range of the compressor. At 50, 60, and 80 percent of design speed, radial surveys were taken for the near-stall weight flow only. Data were recorded at 11 radial positions for each speed and weight flow.

At each radial position the combination probe behind the stator was circumferentially traversed to nine different locations across the stator gap. The wedge probe was set at midgap because previous studies showed that the static pressure across the stator gap was constant. Values of pressure, temperature, and flow angle were recorded at each circumferential position. At the last circumferential position values of pressure, temperature, and flow angle were also recorded at stations 1 and 2. All probes were then traversed to the next radial position, and the circumferential traverse procedure was repeated.

At each of the six rotative speeds the back pressure on the stage was increased by closing the sleeve valve in the collector until a stalled condition was detected by a sudden drop in stage outlet total pressure. This pressure was measured by a probe located at midpassage and was recorded on an X-Y plotter. Stall was corroborated by large increases in the measured blade stresses on both rotor and stator along with a sudden increase in noise level.

Calculation Procedure

Because of the physical construction of the C-shaped static-pressure wedges, it was not possible to obtain static-pressure measurements at 5, 10, and 95 percent of span. The static pressure at 95 percent span was obtained by assuming a linear variation in static pressure between the values at the inner wall and the probe measurement at 90 percent span. A similar variation was assumed between the static-pressure measurements at the outer wall and the 30 percent span to obtain the static pressure at 5 and 10 percent span.

At each radial position, averaged values of the nine circumferential measurements of pressure, temperature, and flow angle downstream of the stator (station 3) were ob-

tained. The nine values of total temperature were mass averaged to obtain the stator outlet total temperature presented. The nine values of total pressure were energy averaged. The measured values of pressure, temperature, and flow angle were used to calculate axial and tangential velocities at each circumferential position. The flow angles presented for each radial position are calculated based on the circumferential mass-averaged angular momentum and the average axial velocity. To obtain the overall performance, the radial values of total temperature were mass averaged, and the values of total pressure were energy averaged.

The data, measured at the three measuring stations, have been translated to the blade leading and trailing edges by the method presented in reference 3.

The weight flow at stall was obtained in the following manner: During operation at the near-stall condition, the collector valve was slowly closed in small increments. At each increment the weight flow was obtained. The weight flow obtained just before stall occurred is called the stall weight flow. The pressure ratio at stall was obtained by extrapolating the total pressure obtained from the survey data to the stall weight flow.

Orifice weight flow, total pressures, static pressures, and temperatures were all corrected to standard sea-level conditions based on the rotor-inlet conditions.

RESULTS AND DISCUSSION

The results from this investigation are presented in three main sections. The overall performances for the rotor and the stage are presented first. Radial distributions of several performance parameters are then presented for the rotor and stator. Finally, the blade-element data are presented for both the rotor and stator. The data presented are computer plotted; occasionally, a data point falls outside the range of parameters shown in the figure and is omitted.

All of the plotted data and some additional performance parameters are presented in tabular form. The overall performance data are presented in table VI (p. 25). The blade-element data are presented for the rotor in tables VII (p. 27) and for the stator in tables VIII (p. 47). The definitions and units used for the tabular data are presented in appendix C.

Overall Performance

The overall performance for rotor 17 and for stage 17-12 are presented in figures 7 and 8. For both of these computer plotted figures, data are presented for speeds from 50 to 100 percent design speed. For the 50, 60, and 80 percent of design speeds, the

overall performance is presented for the near-stall condition only. For the 70, 90, and 100 percent of design speeds, data are presented at several weight flows from choke to the near-stall conditions. Design point values are shown as solid symbols on both figures. The stall lines (dashed lines) shown in figures 7 and 8 were determined using the method discussed in the section Calculation Procedure.

In figures 7 and 8 averaged values of total pressure ratio, total temperature ratio, and temperature rise efficiency are plotted as functions of equivalent weight flow. At a near design weight flow of 30.9 kilograms per second ($207.4 \text{ (kg/sec)/m}^2$ of annulus area), the stage experimental overall temperature-rise efficiency of 0.78 was 7 percentage points lower than the value based on design losses of 0.85. The experimental stage pressure ratio of 1.45 was lower than the design value of 1.57. Peak efficiency for the stage at the design tip speed of 425 meters per second was 0.79 and occurred at an equivalent weight flow of 30.2 kilograms per second. Stage pressure ratio at the peak efficiency point was 1.53.

The rotor experimental overall temperature-rise efficiency of 0.81 at design speed and near the design weight flow of 30.9 kilograms per second was 8 percentage points lower than the design value of 0.89. The rotor total pressure ratio was 1.49, 0.11 lower than the design value of 1.60. Peak efficiency for the rotor was 0.83, and it occurred at the equivalent weight flow of 30.2 kilograms per second. Sources of the relatively high losses in the rotor will be discussed in the blade-element performance sections that follow.

Stall margin for the stage was 23 percent based on equivalent weight flow and total pressure ratio at which peak efficiency occurred as compared with the values at stall.

Radial Distributions

The radial distributions of selected flow and performance parameters for both rotor and stator are shown in figures 9 and 10. The results are presented for three weight flows at design speed. The data shown represent the flow conditions at near stall, peak efficiency, and choke. The design values are shown by solid symbols. In this section performance results at the weight flow corresponding to peak efficiency are compared with design.

Rotor. - The total pressure ratio (fig. 9) is greater than design in the blade tip region and less than design in the region between the damper and the hub. The total-temperature ratio distribution agrees well with design except in the blade tip region where higher values were recorded. The temperature-rise efficiency is less than design across the entire blade span, particularly in the damper region where efficiency is as much as 20 points lower than design. The total loss coefficient distribution shows that

the losses are greater than design across the entire blade, especially in the region between the damper and the hub.

Large values of total loss in the damper region are due to both high shock and high profile losses. Design requirements necessitated an excessively high blade curvature over the leading edge portion of the blade suction surface where the flow is supersonic, resulting in high shock losses. Profile losses in the damper region (table VII) are higher than those observed on several rotors reported in reference 8. These higher profile losses may be attributed to the higher flow rate per unit annulus area and possible deviations in streamlines between peak efficiency and design conditions, resulting in large damper wakes.

Stator. - The total loss coefficient distribution (fig. 10) shows the losses are approximately that of design with exceptions at the hub and rotor damper regions. The loss distribution in the damper region is attributed to a streamline shift through the stator. From the overall performance (figs. 7 and 8) the stator performance at the weight flow corresponding to peak efficiency agrees well with design.

Deviation angles were less than design across the entire blade except in the hub and tip regions.

Variation with Incidence Angle

The variations of selected rotor and stator blade-element flow and performance parameters with incidence angle are presented in figures 11 and 12. The data are given for 70, 90, and 100 percent of rotor design speed at blade elements located at 5, 10, 30, 45, 70, 90, and 95 percent of blade span as measured from the rotor tip trailing edge. Design values are shown by solid symbols. The incidence angle curves are presented primarily for future use in comparing the performance of these blades with others. Only a few brief observations will be made from the curves at present.

Rotor-blade. - The rotor blades were designed for zero incidence angle on the blade suction surface. Minimum loss values, over the range of incidence angles tested, were defined across the entire rotor-blade passage except in the hub region. At design speed the rotor-blade suction-surface incidence angles corresponding to minimum losses were within $\pm 1^\circ$ of the design value over the entire span. The high losses recorded in the damper region are attributed to the large camber over the supersonic portion of the multiple-circular-arc blade, as was previously discussed. For all rotor blade elements at design incidence angle (zero degrees on blade suction surface) the experimental values of blade loading, as indicated by the diffusion factor, were lower than design values while the losses, as shown by the total loss coefficient, were greater than design. As design incidence is approached in the region of the blade between the tip and the dampers, blade

loading deteriorates rapidly, while meridional velocity ratio shows a sharp increase. Apparently the blade passage becomes choked over the outer 50 percent of the span at design incidence. Efficiency at the rotor tip is 8 percentage points less than the design value. Exceptionally high losses are noted in the damper region, resulting in efficiencies approximately 12 percentage points less than design at 45 percent of blade span at design incidence.

In summary it appears that the high measured losses for this rotor at the design condition are caused by a choked-flow condition existing in the region of the blade from the tip to the dampers, excessively high damper losses, and the large camber over the supersonic portion of the multiple-circular-arc blade.

Stator blade. - Minimum losses were defined at each radial station over the entire stator blade. Minimum values of total loss coefficient approximate design values except in the region behind the rotor damper and at the hub. Minimum loss occurred at incidence angles less than design values for all elements with the exceptions of the tip and rotor damper regions. Minimum loss incidence angles for all elements, with exceptions at 30 and 90 percent of blade span, occurred at an overall stage weight flow corresponding to stage peak efficiency. Stator deviation angles are within 2° of the design values at the design incidence angles of zero degree with exceptions at 70 percent of blade span and at the hub.

REMARKS

The transonic compressor stage presented in this report was part of a series of three stages in which the primary variable was weight flow. The stage reported herein was designated to have the highest weight flow of the three. In an attempt to isolate the effect of weight flow, the following design parameters were held constant for this series of rotors: rotor tip speed, flow path geometry, rotor blade loss, rotor solidity, and flow area allowances. The design constraints placed on this series of stages resulted in a penalty to this high weight flow stage; total-pressure ratio and efficiency were significantly lower than design values. The design constraints required that there be appreciably more turning in the forward portion of the rotor blade passage of the high weight flow stage than in the other two rotors. This turning apparently resulted in high local Mach numbers and considerably higher than design loss levels. If the design restrictions were eased to redistribute the turning through the blade passage, a high weight flow stage having reduced losses and better overall performance would probably result.

SUMMARY OF RESULTS

This report presents the aerodynamic design and the overall and blade-element performance of a 50-centimeter-diameter single-stage axial-flow transonic compressor designed for a high weight flow per unit annulus area value of 208 kilograms per second per square meter. Radial surveys of the flow conditions at the rotor inlet, rotor outlet, and stator outlet were made over the stable operating flow range of the stage equivalent rotative speeds from 50 to 100 percent of design speed. Flow and performance parameters were calculated across a number of selected blade elements. The following principal results were obtained:

1. At the design tip speed of 425 meters per second, peak efficiency for both rotor and stage occurred at an equivalent weight flow of 30.2 kilograms per second as compared with the design value of 31.0 kilograms per second (208 (kg/sec)/m^2) of annulus area.

2. For the stage the peak efficiency of 0.79 was 6 percentage points lower than the design value of 0.85. At the near design weight flow of 30.9 kilograms per second, the overall efficiency of 0.78 was 7 percentage points less than design.

3. For the rotor the peak efficiency of 0.83 was 6 percentage points lower than the design value of 0.89. At the near design weight flow of 30.9 kilograms per second, the overall efficiency of 0.81 was 8 percentage points less than design.

4. The stall margin for the stage was 23 percent, based on equivalent weight flow and total pressure ratios at peak efficiency and stall.

5. The experimental radial distribution of total loss coefficient for the rotor shows that high losses occurred in the region between the rotor damper and the hub. These high losses are attributed to both the damper and to the large camber of the supersonic portion of the multiple-circular-arc blade.

6. Stator losses at the overall equivalent weight flow corresponding to stage peak efficiency are approximately equal to design except in the regions of the hub and rotor damper.

7. Rotor blade-element performance indicates that the blade passage over the outer half of the rotor was choked at the overall design equivalent weight flow of 31.0 kilograms per second.

8. Minimum values of total loss coefficient for the stator approximate design values except in the regions of the hub and behind the rotor damper.

Lewis Research Center,

National Aeronautics and Space Administration,

Cleveland, Ohio, July 11, 1973,

501-24.

APPENDIX A

SYMBOLS

A_{an}	annulus area at rotor leading edge, 0.147 m^2
A_f	frontal area at rotor leading edge, 0.198 m^2
C_p	specific heat at constant pressure, $1004 \text{ J}/(\text{kg})(\text{K})$
c	aerodynamic chord, cm
D	diffusion factor
g	acceleration of gravity, $9.8 \text{ m}/\text{sec}^2$
i_{mc}	mean incidence angle, angle between inlet air direction and line tangent to blade mean camber line at leading edge, deg
i_{ss}	suction surface incidence angle, angle between inlet air direction and line tangent to blade suction surface at leading edge, deg
J	mechanical equivalent of heat
N	rotative speed, rpm
P	total pressure, N/cm^2
p	static pressure, N/cm^2
r	radius, cm
SM	stall margin
T	total temperature, K
U	wheel speed, m/sec
V	air velocity, m/sec
W	weight flow, kg/sec
Z	axial distance references from rotor blade hub leading edge, cm
α_c	cone angle, deg
α_s	slope of streamline, deg
β	air angle, angle between air velocity and axial direction, deg
β'_c	relative meridional air angle based on cone angle, $\arctan(\tan \beta'_m \cos \alpha_c / \cos \alpha_s)$, deg
γ	ratio of specific heats

δ	ratio of rotor inlet total pressure to standard pressure of 10.13 N/m ²
δ^0	deviation angle, angle between exit air direction and tangent to blade mean camber line at trailing edge, deg
θ	ratio of rotor inlet total temperature to standard temperature of 288.2 K
η	efficiency
κ_{mc}	angle between the blade mean camber line and the meridional plane, deg
κ_{ss}	angle between the blade suction surface camber line at the leading edge and the meridional plane, deg
σ	solidity, ratio of chord to spacing
$\bar{\omega}$	total loss coefficient
$\bar{\omega}_p$	profile loss coefficient
$\bar{\omega}_s$	shock loss coefficient

Subscripts:

ad	adiabatic (temperature rise)
id	ideal
LE	blade leading edge
m	meridional direction
mom	momentum rise
p	polytropic
TE	blade trailing edge
z	axial direction
θ	tangential direction
1	instrumentation plane upstream of rotor
2	instrumentation plane between rotor and stator
3	instrumentation plane downstream of stator

Superscript:

'	relative to blade
---	-------------------

APPENDIX B

EQUATIONS

Performance parameters are defined as follows:

Suction-surface incidence angle -

$$i_{ss} = (\beta'_c)_{LE} - \kappa_{ss} \quad (B1)$$

Mean incidence angle -

$$i_{mc} = (\beta'_c)_{LE} - (\kappa_{mc})_{LE} \quad (B2)$$

Deviation angle -

$$\delta^o = (\beta'_c)_{TE} - (\kappa_{mc})_{TE} \quad (B3)$$

Diffusion factor -

$$D = 1 - \frac{V'_{TE}}{V'_{LE}} + \left| \frac{(rV_\theta)_{TE} - (rV_\theta)_{LE}}{(r_{TE} + r_{LE})\sigma(V'_{LE})} \right| \quad (B4)$$

Total loss coefficient -

$$\bar{\omega} = \frac{(P'_{id})_{TE} - (P')_{TE}}{(P')_{LE} - (p)_{LE}} \quad (B5)$$

Profile loss coefficient -

$$\bar{\omega}_p = \bar{\omega} - \bar{\omega}_s \quad (B6)$$

Total loss parameter -

$$\frac{\bar{\omega} \cos(\beta'_m)_{TE}}{2\sigma} \quad (B7)$$

Profile loss parameter -

$$\frac{\bar{\omega}_p \cos(\beta'_m)_{TE}}{2\sigma} \quad (B8)$$

Adiabatic (temperature-rise) efficiency -

$$\eta_{ad} = \frac{\left(\frac{P_{TE}}{P_{LE}}\right)^{(\gamma-1)/1} - 1}{\frac{T_{TE}}{T_{LE}} - 1} \quad (B9)$$

Momentum-rise efficiency -

$$\eta_{mom} = \frac{\left(\frac{P_{TE}}{P_{LE}}\right)^{(\gamma-1)/1} - 1}{\frac{(UV_\theta)_{TE} - (UV_\theta)_{LE}}{T_{LE} g J C_p}} \quad (B10)$$

Equivalent weight flow -

$$\frac{W \sqrt{\theta}}{\delta} \quad (B11)$$

Equivalent rotative speed -

$$\frac{N}{\sqrt{\theta}} \quad (B12)$$

Weight flow per unit annulus area -

$$\left(\frac{W\sqrt{\theta}}{\delta} \right) / A_{\text{an}} \quad (\text{B13})$$

Weight flow per unit frontal area -

$$\left(\frac{W\sqrt{\theta}}{\delta} \right) / A_{\text{an}} \quad (\text{B14})$$

Head-rise coefficient -

$$\frac{gJC_p T_{\text{LE}}}{U_{\text{tip}}^2} \left[\left(\frac{P_{\text{TE}}}{P_{\text{LE}}} \right)^{(\gamma-1)/\gamma} - 1 \right] \quad (\text{B15})$$

Flow coefficient -

$$\left(\frac{V_z}{U_{\text{tip}}} \right)_{\text{LE}} \quad (\text{B16})$$

Stall margin -

$$\text{SM} = \left[\frac{\left(\frac{P_{\text{TE}}}{P_{\text{LE}}} \right)_{\text{stall}} \times \left(\frac{W\sqrt{\theta}}{\delta} \right)_{\text{ref}}}{\left(\frac{P_{\text{TE}}}{P_{\text{LE}}} \right)_{\text{ref}} \times \left(\frac{W\sqrt{\theta}}{\delta} \right)_{\text{stall}}} - 1 \right] 100 \quad (\text{B17})$$

Polytropic efficiency -

$$\eta_p = \exp \left[\frac{\left(\frac{P_{TE}}{P_{LE}} \right)^{(\gamma-1)/\gamma}}{\frac{T_{TE}}{T_{LE}}} \right] \quad (B18)$$

APPENDIX C

DEFINITIONS AND UNITS USED IN TABLES

ABS	absolute
AERO CHORD	aerodynamic chord, cm
AREA RATIO	ratio of actual flow area to critical area (where local Mach number is one)
BETAM	meridional air angle, deg
CONE ANGLE	angle between axial direction and conical surface representing blade element, deg
DELTA INC	difference between mean camber blade angle and suction-surface blade angle at leading edge, deg
DEV	deviation angle (defined by eq. (B3)), deg
D-FACT	diffusion factor (defined by eq. (B4))
EFF	adiabatic efficiency (defined by eq. (B9))
IN	inlet (leading edge of blade)
INCIDENCE	incidence angle (suction surface defined by eq. (B1) and mean defined by eq. (B2)), deg
KIC	angle between blade mean camber line at leading edge and meridional plane, deg
KOC	angle between blade mean camber line at trailing edge and meridional plane, deg
KTC	angle between blade mean camber line at transition point and meridional plane, deg
LOSS COEFF	loss coefficient (total defined by eq. (B5) and profile defined by eq. (B6))
LOSS PARAM	loss parameter (total defined by eq. (B7) and profile defined by eq. (B8))
MERID	meridional
MERID VEL R	meridional velocity ratio
OUT	outlet (trailing edge of blade)
PERCENT SPAN	percent of blade span from tip at rotor outlet

PHISS	suction-surface camber ahead of assumed shock location, deg
PRESS	pressure, N/cm^2
PROF	profile
RADII	radius, cm
REL	relative to blade
RI	inlet radius (leading edge of blade), cm
RO	outlet radius (trailing edge of blade), cm
RP	radial position
RPM	equivalent rotative speed, rpm
SETTING ANGLE	angle between aerodynamic chord and meridional plane, deg
SOLIDITY	ratio of aerodynamic chord to blade spacing
SPEED	speed, m/sec
SS	suction surface
STREAMLINE SLOPE	slope of streamline, deg
TANG	tangential
TEMP	temperature, K
TI	thickness of blade at leading edge, cm
TM	thickness of blade at maximum thickness, cm
TO	thickness of blade at trailing edge, cm
TOT	total
TOTAL CAMBER	difference between inlet and outlet blade mean camber lines, deg
VEL	velocity, m/sec
WT FLOW	equivalent weight flow, kg/sec
X FACTOR	ratio of suction-surface camber ahead of assumed shock location of multiple-circular-arc blade section to that of double-circular-arc blade section
ZIC	axial distance to blade leading edge from inlet, cm
ZMC	axial distance to blade maximum thickness point from inlet, cm
ZOC	axial distance to blade trailing edge from inlet, cm
ZTC	axial distance to transition point from inlet, cm

REFERENCES

1. Moore, Royce D.; Urasek, Donald C.; and Kovich, George: Performance of Transonic Fan Stage with Weight Flow per Unit Annulus Area of 178 Kilograms per Second per Square Meter (36.5 (lb/sec)/ft²). NASA TM X-2904, 1973.
2. Kovich, George; Moore, Royce D.; and Urasek, Donald C.: Performance of Transonic Compressor Stage with Weight Flow per Unit Annulus Area of 198 Kilograms per Second per Square Meter (40.6 (lb/sec)/ft²). NASA TM X- 2905, 1973.
3. Ball, Calvin L.; Janetzke, David C.; and Reid, Lonnie: Performance of a 1380-Foot-per-Second-Tip-Speed Axial-Flow Compressor Rotor with a Tip Solidity of 1.50. NASA TM X-2379, 1972.
4. Urasek, Donald C.; and Janetzke, David C.: Overall and Blade-Element Performance of a Tandem-Bladed Transonic Compressor Rotor with Tip Speed of 1375 Feet per Second. NASA TM X-2484, 1972.
5. Schwenk, Francis C.; Lewis, George W.; and Hartmann, Melvin J.: A Preliminary Analysis of the Magnitude of Shock Losses in Transonic Compressors. NACA RM E57A30, 1957.
6. Keenan, M. J.; and Bartok, J. A.: Experimental Evaluation of Transonic Stators, Data and Performance Report, Multiple-Circular-Arc Stator B. Rep. PWA-3356, Pratt & Whitney Aircraft (NASA CR-54622), 1968.
7. Crouse, James E.; Janetzke, David C.; and Schwirian, Richard E.: A Computer Program for Composing Compressor Blading from Simulated Circular-Arc Elements on Conical Surfaces. NASA TN D-5437, 1969.
8. Esgar, Genevieve M.; and Sandercock, Donald M.: Some Observed Effects of Part-Span Dampers on Rotating Blade Row Performance Near Design Point. NASA TM X-2696, 1973.

TABLE I. - DESIGN OVERALL PARAMETERS
FOR STAGE 17-12

ROTOR TOTAL PRESSURE RATIO,.....	1.601
STAGE TOTAL PRESSURE RATIO.....	1.571
ROTOR TOTAL TEMPERATURE RATIO	1.161
STAGE TOTAL TEMPERATURE RATIO	1.161
ROTOR ADIABATIC EFFICIENCY	0.892
STAGE ADIABATIC EFFICIENCY	0.854
ROTOR POLYTROPIC EFFICIENCY	0.899
STAGE POLYTROPIC EFFICIENCY	0.863
ROTOR HEAD RISE COEFFICIENT	0.231
STAGE HEAD RISE COEFFICIENT	0.221
FLOW COEFFICIENT	0.494
WT FLOW PER UNIT FRONTAL AREA	155.182
WT FLOW PER UNIT ANNULUS AREA	208.018
WT FLOW	30.958
RPM.....	16100.000
TIP SPEED	424.858

TABLE II. - DESIGN BLADE-ELEMENT PARAMETERS FOR ROTOR 17

RP	RADII		ABS BETAM		REL BETAM		TOTAL TEMP		TOTAL PRESS	
	IN	OUT	IN	OUT	IN	OUT	IN	RATIO	IN	RATIO
TIP	25.199	24.785	0.	40.0	65.4	60.9	288.2	1.192	10.13	1.601
1	24.615	24.251	-0.	38.7	64.3	60.0	288.2	1.183	10.13	1.601
2	24.044	23.716	0.	37.9	63.3	59.0	288.2	1.176	10.13	1.601
3	21.719	21.579	0.	37.4	59.6	54.3	288.2	1.162	10.13	1.601
4	19.935	19.976	0.	38.2	57.0	49.7	288.2	1.157	10.13	1.601
5	19.633	19.708	0.	38.4	56.6	48.8	288.2	1.156	10.13	1.601
6	19.330	19.441	0.	38.7	56.2	47.9	288.2	1.156	10.13	1.601
7	19.025	19.174	0.	38.9	55.8	46.9	288.2	1.155	10.13	1.601
8	18.719	18.907	0.	39.1	55.4	45.9	288.2	1.155	10.13	1.601
9	16.837	17.303	0.	40.7	52.8	38.6	288.2	1.153	10.13	1.601
10	14.158	15.166	0.	43.9	49.1	24.6	288.2	1.153	10.13	1.601
11	13.446	14.631	0.	45.1	48.0	19.9	288.2	1.154	10.13	1.601
HUB	12.700	14.097	0.	46.4	46.7	14.6	288.2	1.156	10.13	1.601

RP	ABS VEL		REL VEL		MERID VEL		TANG VEL		WHEEL SPEED	
	IN	OUT	IN	OUT	IN	OUT	IN	OUT	IN	OUT
TIP	194.7	207.2	467.3	326.0	194.7	158.8	0.	133.1	424.9	417.9
1	199.9	207.0	460.6	322.6	199.9	161.4	-0.	129.5	415.0	408.9
2	204.2	207.3	453.9	317.9	204.2	163.6	0.	127.3	405.4	399.9
3	215.1	212.2	424.7	289.1	215.1	168.6	0.	128.9	366.2	363.8
4	217.9	217.9	400.6	264.7	217.9	171.1	0.	134.9	336.1	336.8
5	218.0	219.0	396.4	260.5	218.0	171.5	0.	136.2	331.0	332.3
6	218.1	220.2	392.1	256.4	218.1	172.0	0.	137.6	325.9	327.8
7	218.0	221.5	387.9	252.3	218.0	172.4	0.	139.1	320.8	323.3
8	217.9	222.8	385.5	248.2	217.9	172.8	0.	140.6	315.6	318.8
9	215.3	232.1	356.3	225.1	215.3	175.9	0.	151.4	285.9	291.7
10	207.0	249.8	315.9	197.8	207.0	179.9	0.	173.3	238.7	255.7
11	204.4	255.9	305.2	192.0	204.4	180.6	0.	181.4	226.7	246.7
HUB	201.6	263.0	294.1	187.2	201.6	181.2	0.	190.6	214.1	237.7

RP	ABS MACH NO		REL MACH NO		MERID MACH NO		STREAMLINE SLOPE		MERID PEAK SS	
	IN	OUT	IN	OUT	IN	OUT	IN	OUT	VEL R	MACH NO
TIP	0.592	0.576	1.421	0.906	0.592	0.441	-5.68	-8.80	0.815	1.584
1	0.609	0.578	1.403	0.900	0.609	0.450	-5.04	-7.62	0.808	1.571
2	0.623	0.580	1.385	0.890	0.623	0.458	-4.33	-6.47	0.801	1.562
3	0.659	0.599	1.301	0.816	0.659	0.476	-0.79	-2.14	0.784	1.553
4	0.668	0.618	1.229	0.750	0.668	0.485	2.33	0.96	0.785	1.552
5	0.669	0.621	1.216	0.739	0.669	0.487	2.89	1.48	0.787	1.553
6	0.669	0.625	1.203	0.728	0.669	0.488	3.46	2.01	0.789	1.553
7	0.669	0.629	1.190	0.717	0.669	0.490	4.04	2.53	0.791	1.554
8	0.668	0.633	1.176	0.706	0.668	0.491	4.64	3.06	0.793	1.556
9	0.660	0.663	1.092	0.643	0.660	0.502	8.62	6.41	0.817	1.597
10	0.632	0.718	0.965	0.569	0.632	0.517	15.51	11.51	0.869	1.675
11	0.624	0.737	0.931	0.553	0.624	0.520	17.69	12.93	0.884	1.657
HUB	0.614	0.759	0.896	0.540	0.614	0.523	20.16	14.41	0.899	1.633

RP	PERCENT SPAN		INCIDENCE		DEV	D-FACT	EFF	LOSS COEFF		LOSS PARAM	
	SPAN	MEAN	MEAN	SS				TOT	PROF	TOT	PROF
TIP	0.	2.5	-0.0	4.7	0.411	0.748	0.189	0.087	0.035	0.016	
1	5.00	2.8	-0.0	4.3	0.405	0.786	0.158	0.062	0.030	0.012	
2	10.00	3.1	0.0	4.0	0.402	0.818	0.133	0.042	0.025	0.008	
3	30.00	4.1	0.0	2.5	0.421	0.888	0.083	0.007	0.016	0.001	
4	45.00	5.0	0.0	2.3	0.443	0.916	0.065	-0.000	0.013	-0.000	
5	47.50	5.1	0.0	2.3	0.447	0.920	0.063	-0.001	0.013	-0.000	
6	50.00	5.2	0.0	2.3	0.452	0.923	0.061	-0.001	0.012	-0.000	
7	52.50	5.4	0.0	2.3	0.456	0.926	0.060	-0.001	0.012	-0.000	
8	55.00	5.5	0.0	2.3	0.460	0.929	0.058	-0.000	0.012	-0.000	
9	70.00	6.3	0.0	2.3	0.482	0.943	0.051	-0.004	0.010	-0.001	
10	90.00	7.1	-0.0	2.2	0.500	0.940	0.065	0.011	0.013	0.002	
11	95.00	7.3	-0.0	3.0	0.501	0.931	0.079	0.033	0.016	0.006	
HUB	100.00	7.4	-0.0	4.1	0.498	0.919	0.099	0.062	0.019	0.012	

TABLE III. - DESIGN BLADE-ELEMENT PARAMETERS FOR STATOR 12

RP	RADII		ABS BETAM		REL BETAM		TOTAL TEMP		TOTAL PRESS	
	IN	OUT	IN	OUT	IN	OUT	IN	RATIO	IN	RATIO
TIP	24.394	24.384	35.1	0.	35.1	0.	343.7	1.000	16.22	0.972
1	23.903	23.882	34.1	-0.	34.1	-0.	340.9	1.000	16.22	0.978
2	23.438	23.427	33.5	0.	33.5	0.	338.8	1.000	16.22	0.982
3	21.542	21.604	33.6	0.	33.6	0.	334.9	1.000	16.22	0.987
4	20.098	20.233	34.5	0.	34.5	0.	333.4	1.000	16.22	0.985
5	19.856	20.005	34.7	0.	34.7	0.	333.2	1.000	16.22	0.985
6	19.615	19.778	34.9	0.	34.9	0.	333.1	1.000	16.22	0.985
7	19.373	19.550	35.2	0.	35.2	0.	332.9	1.000	16.22	0.984
8	19.131	19.323	35.4	0.	35.4	0.	332.8	1.000	16.22	0.984
9	17.676	17.973	36.9	0.	36.9	0.	332.1	1.000	16.22	0.982
10	15.736	16.216	39.8	0.	39.8	0.	332.3	1.000	16.22	0.973
11	15.254	15.785	40.9	0.	40.9	0.	332.7	1.000	16.22	0.966
HUB	14.643	15.240	42.4	-0.	42.4	-0.	333.4	1.000	16.22	0.955

RP	ABS VEL		REL VEL		MERID VEL		TANG VEL		WHEEL SPEED	
	IN	OUT	IN	OUT	IN	OUT	IN	OUT	IN	OUT
TIP	235.9	184.2	235.9	184.2	193.0	184.2	135.6	0.	0.	0.
1	234.2	186.8	234.2	186.8	193.8	186.8	131.4	-0.	0.	0.
2	233.1	188.7	233.1	188.7	194.3	188.7	128.8	0.	0.	0.
3	233.4	191.9	233.4	191.9	194.4	191.9	129.1	0.	0.	0.
4	236.5	192.6	236.5	192.6	194.9	192.6	134.1	0.	0.	0.
5	237.3	192.7	237.3	192.7	195.0	192.7	135.2	0.	0.	0.
6	238.1	192.9	238.1	192.9	195.2	192.9	136.4	0.	0.	0.
7	239.0	193.2	239.0	193.2	195.4	193.2	137.6	0.	0.	0.
8	240.0	193.4	240.0	193.4	195.7	193.4	139.0	0.	0.	0.
9	247.0	195.5	247.0	195.5	197.6	195.5	148.2	0.	0.	0.
10	260.9	197.2	260.9	197.2	200.4	197.2	167.0	0.	0.	0.
11	265.7	196.9	265.7	196.9	200.8	196.9	174.0	0.	0.	0.
HUB	272.6	196.2	272.6	196.2	201.3	196.2	183.9	-0.	0.	0.

RP	ABS MACH NO		REL MACH NO		MERID MACH NO		STREAMLINE SLOPE		MERID PEAK SS	
	IN	OUT	IN	OUT	IN	OUT	IN	OUT	VEL R	MACH NO
TIP	0.662	0.508	0.662	0.508	0.542	0.508	-1.15	-0.05	0.954	0.923
1	0.660	0.518	0.660	0.518	0.546	0.518	-0.80	0.02	0.964	0.906
2	0.659	0.525	0.659	0.525	0.549	0.525	-0.47	0.10	0.971	0.895
3	0.664	0.538	0.664	0.538	0.553	0.538	1.05	0.74	0.987	0.890
4	0.675	0.541	0.675	0.541	0.556	0.541	2.41	1.36	0.988	0.903
5	0.678	0.542	0.678	0.542	0.557	0.542	2.67	1.47	0.988	0.906
6	0.680	0.543	0.680	0.543	0.558	0.543	2.93	1.59	0.988	0.910
7	0.683	0.544	0.683	0.544	0.559	0.544	3.19	1.71	0.988	0.914
8	0.687	0.544	0.687	0.544	0.560	0.544	3.47	1.83	0.988	0.919
9	0.709	0.551	0.709	0.551	0.568	0.551	5.35	2.63	0.989	0.950
10	0.753	0.556	0.753	0.556	0.579	0.556	8.64	3.92	0.984	1.017
11	0.768	0.555	0.768	0.555	0.581	0.555	9.64	4.24	0.981	1.042
HUB	0.790	0.552	0.790	0.552	0.583	0.552	11.00	4.65	0.975	1.077

RP	PERCENT SPAN		INCIDENCE		DEV	D-FACT	EFF	LOSS COEFF		LOSS PARAM	
	SPAN	MEAN	SS	TOT				PROF	TOT	PROF	
TIP	0.	6.4	-0.0	9.1	0.446	0.	0.116	0.116	0.046	0.046	
1	5.00	6.4	0.0	8.5	0.419	0.	0.089	0.089	0.034	0.034	
2	10.00	6.4	-0.0	8.1	0.400	0.	0.072	0.072	0.027	0.027	
3	30.00	6.4	0.0	7.5	0.370	0.	0.053	0.053	0.018	0.018	
4	45.00	6.4	0.0	7.4	0.370	0.	0.056	0.056	0.018	0.018	
5	47.50	6.4	0.0	7.4	0.370	0.	0.057	0.057	0.018	0.018	
6	50.00	6.4	0.0	7.4	0.371	0.	0.058	0.058	0.018	0.018	
7	52.50	6.4	0.0	7.4	0.372	0.	0.059	0.059	0.018	0.018	
8	55.00	6.4	-0.0	7.4	0.373	0.	0.059	0.059	0.018	0.018	
9	70.00	6.4	0.0	7.4	0.379	0.	0.064	0.064	0.018	0.018	
10	90.00	6.3	0.0	7.6	0.405	0.	0.087	0.087	0.022	0.022	
11	95.00	6.3	0.0	7.7	0.419	0.	0.106	0.106	0.026	0.026	
HUB	100.00	6.3	-0.0	7.9	0.438	0.	0.135	0.135	0.032	0.032	

TABLE IV. - BLADE GEOMETRY FOR ROTOR 17

RP	PERCENT RADII			BLADE ANGLES			DELTA INC	CONE ANGLE
	SPAN	RI	RO	KIC	KTC	KOC		
TIP	0.	25.199	24.785	62.61	61.26	56.06	2.53	-10.696
1	5.	24.615	24.251	61.29	60.07	55.54	2.80	-9.067
2	10.	24.044	23.716	60.05	58.79	54.91	3.06	-7.870
3	30.	21.719	21.579	55.40	52.67	51.81	4.14	-2.944
4	45.	19.935	19.976	52.10	47.65	47.44	4.96	0.778
5	48.	19.633	19.708	51.55	46.77	46.54	5.10	1.412
6	50.	19.330	19.441	51.00	45.88	45.59	5.24	2.051
7	53.	19.025	19.174	50.46	44.98	44.59	5.37	2.692
8	55.	18.719	18.907	49.92	44.05	43.54	5.50	3.339
9	70.	16.837	17.303	46.62	37.38	36.27	6.28	7.494
10	90.	14.158	15.166	42.13	26.40	22.17	7.14	13.984
11	95.	13.446	14.631	40.96	23.50	16.66	7.28	15.844
HUB	100.	12.700	14.097	39.73	20.47	10.26	7.40	17.956

RP	BLADE THICKNESSES			AXIAL DIMENSIONS			
	T1	TM	TO	ZIC	ZMC	ZTC	ZOC
TIP	0.051	0.152	0.051	1.093	2.147	2.552	3.285
1	0.051	0.163	0.051	1.047	2.148	2.518	3.326
2	0.051	0.173	0.051	1.002	2.149	2.481	3.369
3	0.051	0.216	0.051	0.815	2.150	2.283	3.544
4	0.051	0.249	0.051	0.676	2.149	2.080	3.690
5	0.051	0.255	0.051	0.653	2.149	2.042	3.715
6	0.051	0.260	0.051	0.629	2.149	2.002	3.741
7	0.051	0.266	0.051	0.605	2.148	1.961	3.767
8	0.051	0.271	0.051	0.580	2.148	1.918	3.794
9	0.051	0.306	0.051	0.414	2.141	1.616	3.964
10	0.051	0.356	0.051	0.153	2.119	1.099	4.198
11	0.051	0.370	0.051	0.080	2.109	0.951	4.255
HUB	0.051	0.385	0.051	0.000	2.096	0.790	4.311

RP	AERO SETTING TOTAL			X			AREA RATIO
	CHORD	ANGLE	CAMBER	SOLIDITY	FACTOR	PHISS	
TIP	4.639	60.91	6.54	1.300	0.705	4.83	1.041
1	4.627	59.72	5.76	1.326	0.748	4.94	1.040
2	4.624	58.50	5.15	1.356	0.803	5.19	1.040
3	4.615	55.22	3.59	1.493	1.074	7.26	1.040
4	4.613	48.66	4.66	1.619	1.223	9.17	1.040
5	4.613	47.82	5.01	1.642	1.243	9.51	1.040
6	4.614	46.96	5.42	1.667	1.261	9.85	1.040
7	4.615	46.08	5.87	1.692	1.278	10.20	1.040
8	4.616	45.17	6.37	1.718	1.295	10.56	1.040
9	4.636	38.67	10.35	1.902	1.474	13.59	1.039
10	4.721	26.80	19.96	2.255	1.789	18.86	1.028
11	4.760	22.83	24.29	2.374	1.866	20.13	1.025
HUB	4.824	18.30	29.48	2.521	1.945	21.40	1.022

TABLE V. - BLADE GEOMETRY FOR STATOR 12

RP	PERCENT			RADI			BLADE ANGLES			DELTA	CONE
	SPAN	RI	RO	KIC	KTC	KOC	INC	ANGLE			
TIP	0.	24.394	24.384	28.69	24.28	-9.14	6.41	-0.150			
1	5.	23.903	23.882	27.72	23.70	-8.52	6.42	-0.310			
2	10.	23.438	23.427	27.12	23.36	-8.11	6.43	-0.152			
3	30.	21.542	21.604	27.17	23.65	-7.51	6.42	0.915			
4	45.	20.098	20.253	28.12	24.54	-7.39	6.41	1.994			
5	48.	19.856	20.005	28.32	24.73	-7.38	6.41	2.196			
6	50.	19.615	19.778	28.54	24.92	-7.37	6.41	2.404			
7	53.	19.373	19.550	28.77	25.12	-7.37	6.41	2.620			
8	55.	19.131	19.323	29.00	25.34	-7.37	6.40	2.843			
9	70.	17.676	17.973	30.52	26.69	-7.36	6.38	4.394			
10	90.	15.736	16.216	33.59	29.34	-7.57	6.32	7.111			
11	95.	15.254	15.785	34.72	30.29	-7.70	6.30	7.903			
HUB	100.	14.643	15.240	36.33	31.63	-7.91	6.27	8.900			

RP	BLADE THICKNESSES			AXIAL DIMENSIONS			
	TI	TM	TO	ZIC	ZMC	ZTC	ZOC
TIP	0.051	0.279	0.051	7.051	8.902	8.299	10.933
1	0.051	0.279	0.051	7.042	8.904	8.239	10.933
2	0.051	0.279	0.051	7.036	8.906	8.195	10.933
3	0.051	0.279	0.051	7.035	8.907	8.107	10.933
4	0.051	0.279	0.051	7.042	8.906	8.070	10.932
5	0.051	0.279	0.051	7.044	8.905	8.064	10.932
6	0.051	0.279	0.051	7.045	8.905	8.059	10.932
7	0.051	0.279	0.051	7.046	8.904	8.053	10.931
8	0.051	0.279	0.051	7.048	8.903	8.048	10.930
9	0.051	0.279	0.051	7.060	8.900	8.017	10.929
10	0.051	0.279	0.051	7.085	8.893	7.990	10.925
11	0.051	0.279	0.051	7.095	8.890	7.988	10.924
HUB	0.051	0.279	0.051	7.110	8.886	7.988	10.922

RP	AERO CHORD	SETTING		TOTAL CAMBER	X SOLIDITY	X FACTOR	PHISS	AREA RATIO
		ANGLE						
TIP	4.053	14.05		37.83	1.270	0.600	8.81	1.144
1	4.053	13.51		36.24	1.296	0.600	8.23	1.137
2	4.053	13.18		35.23	1.321	0.600	7.83	1.132
3	4.053	13.14		34.68	1.435	0.600	7.29	1.117
4	4.055	13.59		35.50	1.536	0.600	7.21	1.102
5	4.056	13.69		35.70	1.555	0.600	7.21	1.099
6	4.056	13.79		35.91	1.573	0.600	7.21	1.097
7	4.057	13.90		36.13	1.593	0.600	7.22	1.094
8	4.058	14.01		36.37	1.612	0.600	7.23	1.091
9	4.064	14.74		37.88	1.742	0.600	7.26	1.071
10	4.082	16.23		41.16	1.952	0.600	7.55	1.045
11	4.088	16.79		42.42	2.013	0.600	7.70	1.038
HUB	4.098	17.58		44.24	2.095	0.600	7.95	1.030

TABLE VI. - OVERALL PERFORMANCE FOR STAGE 17-12

(a) 100 Percent of design speed

Parameter	Reading number						
	1143	1144	1145	1146	1147	1148	1179
ROTOR TOTAL PRESSURE RATIO	1.435	1.574	1.623	1.634	1.624	1.618	1.490
STAGE TOTAL PRESSURE RATIO	1.363	1.534	1.574	1.573	1.553	1.541	1.453
ROTOR TOTAL TEMPERATURE RATIO	1.137	1.168	1.182	1.189	1.195	1.196	1.148
STAGE TOTAL TEMPERATURE RATIO	1.134	1.164	1.180	1.189	1.193	1.195	1.145
ROTOR TEMP. RISE EFFICIENCY	0.796	0.825	0.817	0.796	0.762	0.750	0.814
STAGE TEMP. RISE EFFICIENCY	0.694	0.791	0.767	0.732	0.693	0.675	0.779
ROTOR MOMENTUM RISE EFFICIENCY	0.782	0.827	0.820	0.794	0.761	0.747	0.791
ROTOR HEAD RISE COEFFICIENT	0.174	0.221	0.257	0.241	0.237	0.236	0.193
STAGE HEAD RISE COEFFICIENT	0.148	0.207	0.221	0.221	0.214	0.211	0.180
FLOW COEFFICIENT	0.443	0.427	0.402	0.369	0.343	0.332	0.439
WT FLOW PER UNIT FRONTAL AREA	155.40	151.60	145.11	136.73	129.27	125.69	154.74
WT FLOW PER UNIT ANNULUS AREA	208.30	203.21	194.51	183.28	173.28	168.49	207.42
WT FLOW AT ORIFICE	31.00	30.24	28.95	27.28	25.79	25.07	30.87
WT FLOW AT ROTOR INLET	31.14	30.37	29.09	27.31	25.79	25.09	30.95
WT FLOW AT ROTOR OUTLET	31.90	31.01	29.88	28.59	27.18	26.51	31.32
WT FLOW AT STATOR OUTLET	32.40	30.54	29.56	28.52	27.57	27.14	31.18
ROTATIVE SPEED	16113.4	16138.4	16126.4	16128.4	16133.5	16103.5	16111.1
PERCENT OF DESIGN SPEED	100.1	100.2	100.2	100.2	100.2	100.0	100.1

(b) 90 Percent of design speed

Parameter	Reading number					
	1151	1152	1153	1154	1155	1156
ROTOR TOTAL PRESSURE RATIO	1.357	1.421	1.462	1.473	1.472	1.472
STAGE TOTAL PRESSURE RATIO	1.295	1.392	1.426	1.432	1.426	1.413
ROTOR TOTAL TEMPERATURE RATIO	1.103	1.123	1.136	1.145	1.150	1.160
STAGE TOTAL TEMPERATURE RATIO	1.102	1.121	1.133	1.142	1.149	1.158
ROTOR TEMP. RISE EFFICIENCY	0.839	0.860	0.840	0.804	0.777	0.732
STAGE TEMP. RISE EFFICIENCY	0.754	0.821	0.806	0.762	0.718	0.658
ROTOR MOMENTUM RISE EFFICIENCY	0.827	0.857	0.842	0.806	0.771	0.726
ROTOR HEAD RISE COEFFICIENT	0.171	0.209	0.227	0.231	0.231	0.231
STAGE HEAD RISE COEFFICIENT	0.152	0.196	0.211	0.213	0.211	0.205
FLOW COEFFICIENT	0.450	0.430	0.399	0.367	0.340	0.306
WT FLOW PER UNIT FRONTAL AREA	145.78	141.17	133.25	124.97	117.35	107.43
WT FLOW PER UNIT ANNULUS AREA	195.42	189.24	178.61	167.53	157.30	144.00
WT FLOW AT ORIFICE	29.08	28.16	26.58	24.93	23.41	21.43
WT FLOW AT ROTOR INLET	29.22	28.27	26.66	24.98	23.44	21.41
WT FLOW AT ROTOR OUTLET	30.13	29.22	27.78	26.23	24.65	22.53
WT FLOW AT STATOR OUTLET	30.13	28.67	27.15	25.74	24.58	23.43
ROTATIVE SPEED	14483.6	14485.7	14490.8	14501.1	14503.5	14504.8
PERCENT OF DESIGN SPEED	90.0	90.0	90.0	90.1	90.1	90.1

(c) 80 Percent of design speed

Parameter	Reading number
	1157
ROTOR TOTAL PRESSURE RATIO	1.363
STAGE TOTAL PRESSURE RATIO	1.323
ROTOR TOTAL TEMPERATURE RATIO	1.125
STAGE TOTAL TEMPERATURE RATIO	1.123
ROTOR TEMP. RISE EFFICIENCY	0.742
STAGE TEMP. RISE EFFICIENCY	0.676
ROTOR MOMENTUM RISE EFFICIENCY	0.742
ROTOR HEAD RISE COEFFICIENT	0.231
STAGE HEAD RISE COEFFICIENT	0.208
FLOW COEFFICIENT	0.305
WT FLOW PER UNIT FRONTAL AREA	96.54
WT FLOW PER UNIT ANNULUS AREA	129.41
WT FLOW AT ORIFICE	19.26
WT FLOW AT ROTOR INLET	19.20
WT FLOW AT ROTOR OUTLET	20.26
WT FLOW AT STATOR OUTLET	20.62
ROTATIVE SPEED	12891.2
PERCENT OF DESIGN SPEED	80.1

TABLE VI. - Concluded. OVERALL PERFORMANCE FOR

STAGE 17-12

(d) 70 Percent of design speed

Parameter	Reading number			
	1173	1174	1175	1176
ROTOR TOTAL PRESSURE RATIO	1.181	1.225	1.257	1.267
STAGE TOTAL PRESSURE RATIO	1.167	1.210	1.239	1.241
ROTOR TOTAL TEMPERATURE RATIO	1.055	1.068	1.083	1.094
STAGE TOTAL TEMPERATURE RATIO	1.055	1.067	1.082	1.092
ROTOR TEMP. RISE EFFICIENCY	0.883	0.871	0.810	0.744
STAGE TEMP. RISE EFFICIENCY	0.819	0.831	0.768	0.690
ROTOR MOMENTUM RISE EFFICIENCY	0.857	0.859	0.804	0.744
ROTOR HEAD RISE COEFFICIENT	0.159	0.193	0.220	0.230
STAGE HEAD RISE COEFFICIENT	0.147	0.183	0.206	0.209
FLOW COEFFICIENT	0.446	0.408	0.347	0.302
WT FLOW PER UNIT FRONTAL AREA	118.90	110.33	96.07	84.33
WT FLOW PER UNIT ANNULUS AREA	159.38	147.90	128.78	113.05
WT FLOW AT ORIFICE	23.72	22.01	19.17	16.82
WT FLOW AT ROTOR INLET	23.82	22.07	19.14	16.79
WT FLOW AT ROTOR OUTLET	24.18	22.49	19.73	17.18
WT FLOW AT STATOR OUTLET	24.11	22.30	19.52	17.82
ROTATIVE SPEED	11281.9	11278.6	11283.5	11244.9
PERCENT OF DESIGN SPEED	70.1	70.1	70.1	69.8

(e) 60 Percent of design speed

Parameter	Reading number
	1177
ROTOR TOTAL PRESSURE RATIO	1.193
STAGE TOTAL PRESSURE RATIO	1.174
ROTOR TOTAL TEMPERATURE RATIO	1.069
STAGE TOTAL TEMPERATURE RATIO	1.067
ROTOR TEMP. RISE EFFICIENCY	0.752
STAGE TEMP. RISE EFFICIENCY	0.695
ROTOR MOMENTUM RISE EFFICIENCY	0.754
ROTOR HEAD RISE COEFFICIENT	0.232
STAGE HEAD RISE COEFFICIENT	0.211
FLOW COEFFICIENT	0.295
WT FLOW PER UNIT FRONTAL AREA	71.20
WT FLOW PER UNIT ANNULUS AREA	95.45
WT FLOW AT ORIFICE	14.20
WT FLOW AT ROTOR INLET	14.17
WT FLOW AT ROTOR OUTLET	14.53
WT FLOW AT STATOR OUTLET	14.98
ROTATIVE SPEED	9607.0
PERCENT OF DESIGN SPEED	59.7

(f) 50 Percent of design speed

Parameter	Reading number
	1178
ROTOR TOTAL PRESSURE RATIO	1.134
STAGE TOTAL PRESSURE RATIO	1.122
ROTOR TOTAL TEMPERATURE RATIO	1.048
STAGE TOTAL TEMPERATURE RATIO	1.047
ROTOR TEMP. RISE EFFICIENCY	0.760
STAGE TEMP. RISE EFFICIENCY	0.704
ROTOR MOMENTUM RISE EFFICIENCY	0.761
ROTOR HEAD RISE COEFFICIENT	0.234
STAGE HEAD RISE COEFFICIENT	0.213
FLOW COEFFICIENT	0.290
WT FLOW PER UNIT FRONTAL AREA	59.23
WT FLOW PER UNIT ANNULUS AREA	79.40
WT FLOW AT ORIFICE	11.82
WT FLOW AT ROTOR INLET	11.77
WT FLOW AT ROTOR OUTLET	12.15
WT FLOW AT STATOR OUTLET	12.46
ROTATIVE SPEED	8064.8
PERCENT OF DESIGN SPEED	50.1

TABLE VII. - BLADE-ELEMENT DATA AT BLADE EDGES FOR ROTOR 17

(a) 100 Percent of design speed; reading number 1143

RP	RADII		ABS BETAM		REL BETAM		TOTAL TEMP		TOTAL PRESS	
	IN	OUT	IN	OUT	IN	OUT	IN	RATIO	IN	RATIO
1	24.615	24.252	-0.3	29.9	64.2	57.7	288.8	1.154	10.08	1.444
2	24.044	23.716	-0.3	28.6	63.0	56.6	288.7	1.147	10.13	1.443
3	21.720	21.580	-0.3	27.8	59.9	53.2	288.1	1.129	10.13	1.428
4	19.934	19.975	-0.3	31.5	57.1	47.5	288.1	1.139	10.14	1.431
5	19.632	19.708	-0.3	32.2	56.7	47.8	287.9	1.137	10.14	1.401
6	19.329	19.441	-0.3	32.6	56.2	49.7	287.9	1.129	10.14	1.350
7	19.025	19.174	-0.3	33.3	55.7	51.1	287.9	1.125	10.14	1.314
8	18.720	18.908	-0.3	34.2	55.2	49.3	288.0	1.128	10.14	1.327
9	16.838	17.302	-0.3	32.8	52.4	38.1	287.9	1.130	10.14	1.432
10	14.158	15.166	-0.2	35.4	48.3	23.0	287.8	1.138	10.15	1.523
11	13.447	14.630	-0.2	36.5	47.4	21.3	287.8	1.138	10.14	1.505

RP	ABS VEL		REL VEL		MERID VEL		TANG VEL		WHEEL SPEED	
	IN	OUT	IN	OUT	IN	OUT	IN	OUT	IN	OUT
1	201.2	218.4	461.8	354.4	201.1	189.2	-0.9	109.0	414.8	408.7
2	207.0	221.1	456.4	352.6	207.0	194.1	-1.0	105.9	405.7	400.2
3	212.7	220.8	424.4	325.9	212.7	195.2	-1.0	103.1	366.3	364.0
4	217.8	232.1	401.5	292.7	217.8	197.9	-1.0	121.3	336.3	337.0
5	218.5	226.7	397.7	285.7	218.5	191.9	-1.0	120.8	331.2	332.5
6	219.1	214.0	393.7	278.7	219.1	180.3	-1.0	115.4	326.0	327.9
7	219.5	203.9	389.6	271.5	219.5	170.4	-1.0	112.0	320.9	323.4
8	219.8	209.3	385.5	265.3	219.8	173.0	-1.0	117.8	315.8	318.9
9	219.5	243.1	359.8	259.7	219.5	204.3	-1.0	131.7	284.2	292.0
10	213.6	276.9	321.2	245.2	213.6	225.8	-0.9	160.4	239.1	256.1
11	210.1	272.6	310.3	235.0	210.1	219.0	-0.9	162.3	227.4	247.5

RP	ABS MACH NO		REL MACH NO		MERID MACH NO		MERID PEAK SS	
	IN	OUT	IN	OUT	IN	OUT	VEL R	MACH NO
1	0.612	0.619	1.406	1.005	0.612	0.537	0.941	1.570
2	0.632	0.630	1.392	1.004	0.632	0.553	0.938	1.561
3	0.651	0.635	1.299	0.937	0.651	0.561	0.918	1.563
4	0.668	0.667	1.232	0.841	0.668	0.569	0.908	1.558
5	0.671	0.651	1.221	0.821	0.671	0.551	0.878	1.558
6	0.673	0.614	1.209	0.800	0.673	0.517	0.823	1.557
7	0.674	0.584	1.196	0.778	0.674	0.488	0.776	1.557
8	0.675	0.600	1.184	0.760	0.675	0.496	0.787	1.557
9	0.674	0.705	1.105	0.753	0.674	0.593	0.931	1.592
10	0.654	0.812	0.984	0.719	0.654	0.662	1.057	1.684
11	0.643	0.798	0.949	0.688	0.643	0.641	1.042	1.670

RP	PERCENT	INCIDENCE		DEV	D-FACT	EFF	LOSS COEFF		LOSS PARAM	
	SPAN	MEAN	SS				TOT	PROF	TOT	PROF
1	5.00	2.7	-0.1	2.1	0.322	0.719	0.178	0.081	0.036	0.016
2	10.00	2.8	-0.2	1.6	0.313	0.751	0.154	0.062	0.031	0.013
3	30.00	4.5	0.4	1.4	0.314	0.828	0.104	0.026	0.021	0.005
4	45.00	5.1	0.1	0.0	0.365	0.776	0.153	0.086	0.032	0.018
5	47.50	5.1	0.0	1.3	0.375	0.740	0.177	0.111	0.036	0.023
6	50.00	5.2	-0.0	4.1	0.381	0.693	0.200	0.136	0.039	0.026
7	52.50	5.3	-0.1	6.5	0.389	0.648	0.224	0.163	0.042	0.030
8	55.00	5.4	-0.1	5.8	0.402	0.657	0.226	0.166	0.043	0.032
9	70.00	5.9	-0.4	1.8	0.376	0.831	0.127	0.071	0.026	0.015
10	90.00	6.4	-0.7	0.6	0.352	0.928	0.069	0.010	0.014	0.002
11	95.00	6.7	-0.6	4.3	0.358	0.899	0.101	0.050	0.020	0.010

TABLE VII. - Continued. BLADE-ELEMENT DATA AT BLADE

EDGES FOR ROTOR 17

(b) 100 Percent of design speed; reading number 1144

RP	RADII		ABS BETAM		REL BETAM		TOTAL TEMP		TOTAL PRESS	
	IN	OUT	IN	OUT	IN	OUT	IN	RATIO	IN	RATIO
1	24.615	24.252	-0.3	39.8	65.0	56.5	288.8	1.210	10.06	1.642
2	24.044	23.716	-0.3	36.4	63.8	55.9	288.6	1.188	10.13	1.630
3	21.720	21.580	-0.3	36.1	60.8	53.0	288.1	1.165	10.13	1.588
4	19.934	19.975	-0.3	38.5	58.2	47.5	288.0	1.162	10.14	1.580
5	19.632	19.708	-0.3	39.1	57.7	47.6	288.2	1.162	10.14	1.557
6	19.329	19.441	-0.3	40.3	57.3	48.1	288.0	1.161	10.14	1.527
7	19.025	19.174	-0.3	42.6	56.9	49.1	287.9	1.161	10.14	1.491
8	18.720	18.908	-0.3	43.6	56.5	48.3	287.9	1.163	10.14	1.483
9	16.858	17.302	-0.3	40.7	53.9	38.3	287.9	1.154	10.14	1.533
10	14.158	15.166	-0.2	40.7	50.0	24.7	287.8	1.150	10.14	1.573
11	13.447	14.630	-0.2	42.0	49.0	21.6	287.9	1.151	10.13	1.555

RP	ABS VEL		REL VEL		MERID VEL		TANG VEL		WHEEL SPEED	
	IN	OUT	IN	OUT	IN	OUT	IN	OUT	IN	OUT
1	194.2	227.2	459.6	316.7	194.2	174.7	-0.9	145.3	415.6	409.5
2	200.8	225.1	454.5	323.1	200.8	181.1	-1.0	133.7	406.8	401.2
3	205.8	219.5	421.3	294.5	205.8	177.4	-0.9	129.3	366.7	364.4
4	209.0	228.1	396.8	264.4	209.0	178.5	-0.9	142.1	336.4	337.1
5	209.9	224.9	393.4	258.7	209.9	174.4	-0.9	142.0	331.7	333.0
6	210.2	219.6	389.1	250.6	210.2	167.5	-0.9	141.9	326.5	328.4
7	210.1	212.2	384.8	238.8	210.1	156.3	-1.0	143.5	321.5	324.0
8	210.5	212.7	380.9	231.7	210.5	154.1	-1.0	146.7	316.5	319.7
9	208.6	233.9	353.8	225.9	208.6	177.2	-0.9	152.6	284.8	292.7
10	201.3	256.2	313.4	213.7	201.3	194.2	-0.8	167.2	239.4	256.5
11	198.2	256.8	302.4	205.2	198.2	190.7	-0.8	172.0	227.5	247.5

RP	ABS MACH NO		REL MACH NO		MERID MACH NO		MERID PEAK SS	
	IN	OUT	IN	OUT	IN	OUT	VEL R	MACH NO
1	0.590	0.630	1.395	0.878	0.590	0.484	0.899	1.588
2	0.611	0.630	1.384	0.904	0.611	0.507	0.902	1.578
3	0.628	0.620	1.286	0.832	0.628	0.501	0.862	1.579
4	0.639	0.648	1.213	0.750	0.639	0.507	0.854	1.579
5	0.642	0.637	1.203	0.733	0.642	0.494	0.831	1.580
6	0.643	0.622	1.190	0.710	0.643	0.474	0.797	1.580
7	0.643	0.599	1.177	0.674	0.643	0.441	0.744	1.582
8	0.644	0.601	1.165	0.654	0.644	0.435	0.732	1.584
9	0.638	0.668	1.082	0.645	0.638	0.506	0.850	1.626
10	0.614	0.740	0.956	0.617	0.614	0.561	0.965	1.691
11	0.604	0.742	0.921	0.592	0.604	0.551	0.962	1.673

RP	PERCENT	INCIDENCE		DEV	D-FACT	EFF	LOSS COEFF		LOSS PARAM	
	SPAN	MEAN	SS				TOT	PROF	TOT	PROF
1	5.00	3.5	0.7	0.9	0.430	0.725	0.225	0.126	0.047	0.026
2	10.00	3.6	0.5	0.9	0.398	0.797	0.156	0.061	0.032	0.013
3	30.00	5.3	1.2	1.1	0.404	0.856	0.110	0.030	0.022	0.006
4	45.00	6.1	1.2	0.1	0.445	0.859	0.113	0.044	0.024	0.009
5	47.50	6.2	1.1	1.1	0.453	0.832	0.136	0.069	0.028	0.014
6	50.00	6.3	1.1	2.5	0.466	0.798	0.164	0.098	0.033	0.020
7	52.50	6.5	1.1	4.5	0.491	0.750	0.204	0.140	0.039	0.027
8	55.00	6.6	1.1	4.8	0.505	0.733	0.222	0.159	0.043	0.031
9	70.00	7.3	1.1	2.0	0.477	0.842	0.142	0.082	0.029	0.017
10	90.00	8.1	1.0	2.3	0.441	0.921	0.084	0.028	0.017	0.006
11	95.00	8.3	1.1	4.7	0.447	0.891	0.122	0.075	0.024	0.015

TABLE VII. - Continued. BLADE-ELEMENT DATA AT BLADE

EDGES FOR ROTOR 17

(c) 100 Percent of design speed; reading number 1145

RP	RADI I		ABS BETAM		REL BETAM		TOTAL TEMP		TOTAL PRESS	
	IN	OUT	IN	OUT	IN	OUT	IN	RATIO	IN	RATIO
1	24.615	24.252	-0.3	42.9	66.2	56.1	288.8	1.228	10.09	1.719
2	24.044	25.716	-0.3	41.0	65.2	55.4	288.6	1.209	10.12	1.699
3	21.720	21.580	-0.3	40.2	62.3	53.1	288.1	1.181	10.14	1.638
4	19.934	19.975	-0.3	41.8	59.9	48.7	288.0	1.173	10.13	1.608
5	19.632	19.708	-0.3	42.9	59.5	48.3	287.8	1.172	10.14	1.594
6	19.329	19.441	-0.3	43.8	59.2	48.0	287.8	1.173	10.14	1.582
7	19.025	19.174	-0.3	46.0	58.8	48.1	288.3	1.176	10.14	1.558
8	18.720	18.908	-0.3	48.0	58.3	47.7	287.9	1.176	10.15	1.543
9	16.858	17.302	-0.3	44.8	55.8	37.7	287.9	1.165	10.14	1.574
10	14.158	15.166	-0.2	43.7	52.1	25.1	287.9	1.156	10.14	1.587
11	13.447	14.630	-0.2	44.7	51.0	20.7	287.9	1.156	10.13	1.588

RP	ABS VEL		REL VEL		MERID VEL		TANG VEL		WHEEL SPEED	
	IN	OUT	IN	OUT	IN	OUT	IN	OUT	IN	OUT
1	184.1	231.5	455.9	304.1	184.1	169.6	-0.9	157.6	416.2	410.0
2	188.4	228.7	448.5	304.0	188.4	172.5	-0.9	150.2	406.1	400.6
3	193.1	219.2	415.4	278.9	193.1	167.5	-0.9	141.4	366.9	364.5
4	195.7	222.3	389.9	251.3	195.7	165.8	-0.9	148.2	336.4	337.1
5	195.6	221.1	385.4	243.8	195.6	162.0	-0.9	150.4	331.2	332.5
6	195.6	219.8	391.5	237.1	195.6	158.5	-0.9	152.2	326.7	328.6
7	195.7	217.0	377.2	225.7	195.7	150.7	-0.9	156.2	321.6	324.1
8	195.5	215.7	372.1	214.6	195.5	144.4	-0.9	160.2	315.8	318.9
9	193.5	232.7	344.3	208.9	193.5	165.2	-0.9	163.9	283.9	291.8
10	186.9	249.1	304.3	198.9	186.9	180.1	-0.8	172.0	239.3	256.3
11	184.2	254.2	293.0	193.1	184.2	180.6	-0.8	178.9	227.1	247.1

RP	ABS MACH NO		REL MACH NO		MERID MACH NO		MERID PEAK SS	
	IN	OUT	IN	OUT	IN	OUT	VEL R	MACH NO
1	0.557	0.638	1.379	0.858	0.557	0.467	0.921	1.615
2	0.571	0.635	1.359	0.844	0.571	0.479	0.915	1.602
3	0.587	0.615	1.262	0.782	0.587	0.470	0.867	1.609
4	0.595	0.627	1.186	0.709	0.595	0.467	0.847	1.613
5	0.595	0.623	1.173	0.687	0.595	0.457	0.829	1.615
6	0.595	0.619	1.161	0.668	0.595	0.447	0.811	1.619
7	0.595	0.610	1.147	0.634	0.595	0.423	0.770	1.621
8	0.595	0.606	1.132	0.603	0.595	0.406	0.739	1.621
9	0.593	0.661	1.047	0.593	0.588	0.469	0.854	1.673
10	0.567	0.715	0.923	0.571	0.567	0.517	0.963	1.698
11	0.558	0.731	0.888	0.555	0.558	0.520	0.981	1.675

RP	PERCENT		INCIDENCE		DEV	D-FACT	EFF	LOSS COEFF		LOSS PARAM	
	SPAN	MEAN	MEAN	SS				TOT	PROF	TOT	PROF
1	5.00	5.7	1.9	0.5	0.463	0.735	0.233	0.131	0.049	0.028	
2	10.00	5.0	1.9	0.4	0.445	0.782	0.185	0.089	0.039	0.019	
3	30.00	6.9	2.7	1.3	0.443	0.837	0.136	0.053	0.027	0.011	
4	45.00	7.8	2.8	1.3	0.474	0.841	0.138	0.066	0.028	0.013	
5	47.50	8.0	2.9	1.8	0.487	0.829	0.149	0.079	0.030	0.016	
6	50.00	8.2	3.0	2.5	0.499	0.808	0.171	0.101	0.034	0.020	
7	52.50	8.3	3.0	3.5	0.525	0.769	0.209	0.141	0.041	0.028	
8	55.00	8.4	2.9	4.1	0.550	0.749	0.230	0.165	0.045	0.032	
9	70.00	9.3	3.0	1.4	0.521	0.837	0.161	0.097	0.034	0.020	
10	90.00	10.2	3.0	2.7	0.477	0.905	0.110	0.056	0.022	0.011	
11	95.00	10.4	3.1	3.8	0.476	0.905	0.116	0.072	0.023	0.014	

TABLE VII. - Continued. BLADE-ELEMENT DATA AT BLADE

EDGES FOR ROTOR 17

(d) 100 Percent of design speed; reading number 1146

RP	RADI I		ABS BETAM		REL BETAM		TOTAL TEMP		TOTAL PRESS	
	IN	OUT	IN	OUT	IN	OUT	IN	RATIO	IN	RATIO
1	24.615	24.252	-0.3	45.5	68.1	56.0	288.8	1.235	10.06	1.744
2	24.044	23.716	-0.3	43.9	67.0	55.0	288.7	1.219	10.11	1.725
3	21.720	21.580	-0.3	42.4	64.4	53.2	288.1	1.188	10.14	1.647
4	19.934	19.975	-0.3	45.5	62.2	49.7	288.0	1.182	10.15	1.603
5	19.632	19.708	-0.3	46.7	61.8	49.4	288.0	1.183	10.15	1.593
6	19.329	19.441	-0.3	48.4	61.4	48.8	287.8	1.184	10.15	1.582
7	19.025	19.174	-0.3	50.2	61.0	48.9	288.0	1.184	10.14	1.560
8	18.720	18.908	-0.3	52.1	60.6	48.3	288.3	1.186	10.15	1.553
9	16.838	17.302	-0.3	47.6	58.3	38.9	287.8	1.171	10.15	1.563
10	14.158	15.166	-0.2	44.9	54.4	23.8	287.8	1.161	10.15	1.613
11	13.447	14.630	-0.2	45.0	53.4	20.3	287.8	1.159	10.14	1.603

RP	ABS VEL		REL VEL		MERID VEL		TANG VEL		WHEEL SPEED	
	IN	OUT	IN	OUT	IN	OUT	IN	OUT	IN	OUT
1	167.5	234.2	449.3	293.1	167.5	164.1	-0.8	167.1	416.1	410.0
2	172.4	232.3	441.4	291.7	172.4	167.4	-0.8	161.0	405.5	400.0
3	176.1	219.2	407.1	270.0	176.1	161.9	-0.8	147.8	366.2	363.8
4	178.1	219.1	381.5	237.4	178.1	153.6	-0.8	156.2	336.6	337.3
5	178.7	218.2	377.7	229.9	178.7	149.6	-0.8	158.8	332.0	333.2
6	178.4	217.8	372.8	219.9	178.4	144.7	-0.8	162.8	326.5	328.4
7	178.4	215.5	368.0	209.7	178.4	137.9	-0.8	165.6	321.1	323.6
8	178.5	216.2	364.0	199.6	178.5	132.9	-0.8	170.6	316.4	319.6
9	176.4	228.0	335.6	197.5	176.4	153.6	-0.8	168.5	284.7	292.5
10	171.6	251.9	295.1	195.0	171.6	178.5	-0.7	177.8	239.4	256.4
11	169.1	254.9	283.5	192.3	169.1	180.3	-0.7	180.2	226.9	246.9

RP	ABS MACH NO		REL MACH NO		MERID MACH NO		MERID PEAK SS	
	IN	OUT	IN	OUT	IN	OUT	VEL R	MACH NO
1	0.504	0.644	1.352	0.806	0.504	0.451	0.980	1.653
2	0.520	0.643	1.330	0.807	0.520	0.463	0.971	1.637
3	0.532	0.613	1.250	0.755	0.532	0.453	0.919	1.651
4	0.538	0.614	1.154	0.666	0.538	0.431	0.862	1.664
5	0.540	0.611	1.142	0.644	0.540	0.419	0.838	1.668
6	0.540	0.610	1.128	0.616	0.540	0.405	0.811	1.671
7	0.539	0.603	1.113	0.587	0.539	0.386	0.773	1.672
8	0.539	0.604	1.100	0.558	0.539	0.371	0.744	1.678
9	0.533	0.645	1.015	0.558	0.533	0.435	0.871	1.745
10	0.518	0.723	0.891	0.559	0.518	0.512	1.040	1.713
11	0.510	0.733	0.855	0.553	0.510	0.518	1.066	1.685

RP	PERCENT SPAN	INCIDENCE		DEV	D-FACT	EFF	LOSS COEFF		LOSS PARAM	
		MEAN	SS				TOT	PROF	TOT	PROF
1	5.00	6.7	3.9	0.3	0.487	0.733	0.246	0.139	0.052	0.029
2	10.00	6.8	3.8	-0.0	0.473	0.769	0.207	0.107	0.044	0.023
3	30.00	8.9	4.8	1.3	0.459	0.817	0.160	0.073	0.032	0.015
4	45.00	10.1	5.1	2.3	0.505	0.793	0.191	0.113	0.038	0.023
5	47.50	10.2	5.1	2.8	0.520	0.780	0.206	0.129	0.041	0.025
6	50.00	10.4	5.2	3.3	0.542	0.762	0.227	0.151	0.045	0.030
7	52.50	10.6	5.2	4.3	0.564	0.735	0.256	0.182	0.050	0.035
8	55.00	10.8	5.3	4.7	0.589	0.722	0.274	0.200	0.053	0.039
9	70.00	11.7	5.5	2.6	0.546	0.794	0.216	0.139	0.044	0.028
10	90.00	12.5	5.4	1.4	0.478	0.909	0.113	0.061	0.023	0.012
11	95.00	12.7	5.4	3.4	0.462	0.910	0.117	0.076	0.023	0.015

TABLE VII. - Continued. BLADE-ELEMENT DATA AT BLADE

EDGES FOR ROTOR 17

(e) 100 Percent of design speed; reading number 1147

RP	RADII		ABS BETAM		REL BETAM		TOTAL TEMP		TOTAL PRESS	
	IN	OUT	IN	OUT	IN	OUT	IN	RATIO	IN	RATIO
1	24.615	24.252	-0.3	48.2	69.6	56.0	289.4	1.250	10.06	1.736
2	24.044	23.716	-0.3	45.8	68.8	54.7	289.3	1.231	10.10	1.728
3	21.720	21.580	-0.3	44.8	66.1	54.2	288.0	1.193	10.14	1.622
4	19.934	19.975	-0.3	48.9	64.0	50.4	288.0	1.191	10.15	1.587
5	19.632	19.708	-0.3	50.3	63.7	50.2	287.8	1.191	10.14	1.577
6	19.329	19.441	-0.3	52.1	63.4	50.2	287.6	1.190	10.15	1.561
7	19.025	19.174	-0.3	53.7	62.9	50.2	287.9	1.190	10.15	1.547
8	18.720	18.908	-0.3	55.4	62.6	49.7	287.7	1.190	10.15	1.537
9	16.838	17.302	-0.3	49.4	60.1	39.5	287.7	1.174	10.15	1.550
10	14.158	15.166	-0.2	44.3	56.1	23.8	287.6	1.160	10.15	1.619
11	13.447	14.630	-0.2	44.8	55.0	20.6	287.6	1.157	10.14	1.602

RP	ABS VEL		REL VEL		MERID VEL		TANG VEL		WHEEL SPEED	
	IN	OUT	IN	OUT	IN	OUT	IN	OUT	IN	OUT
1	154.9	236.3	444.3	281.4	154.9	157.4	-0.8	176.3	415.7	409.5
2	157.6	235.1	435.7	283.3	157.6	163.8	-0.7	168.7	405.4	399.9
3	162.7	215.9	401.8	261.6	162.7	153.2	-0.8	152.1	366.6	364.3
4	164.8	218.1	375.9	224.9	164.8	143.2	-0.8	164.4	337.1	337.8
5	164.8	217.2	371.5	216.7	164.8	138.8	-0.8	167.1	332.2	333.5
6	164.3	215.2	366.4	206.8	164.3	132.3	-0.8	169.7	326.8	328.7
7	164.7	213.9	362.0	197.5	164.7	126.5	-0.7	172.5	321.7	324.2
8	164.6	214.0	357.5	188.1	164.6	121.6	-0.8	176.1	316.5	319.7
9	163.8	225.7	329.0	190.5	163.8	147.0	-0.7	171.2	284.6	292.4
10	161.4	252.3	289.0	197.3	161.4	180.5	-0.7	176.3	239.0	256.1
11	159.4	254.2	277.9	192.6	159.4	180.3	-0.7	179.2	227.0	247.0

RP	ABS MACH NO		REL MACH NO		MERID MACH NO		MERID PEAK SS	
	IN	OUT	IN	OUT	IN	OUT	VEL R	MACH NO
1	0.464	0.645	1.331	0.768	0.464	0.429	1.016	1.683
2	0.473	0.647	1.306	0.780	0.473	0.451	1.039	1.675
3	0.489	0.602	1.209	0.729	0.489	0.427	0.942	1.693
4	0.496	0.609	1.132	0.628	0.496	0.400	0.869	1.710
5	0.496	0.606	1.119	0.605	0.496	0.387	0.842	1.715
6	0.495	0.601	1.104	0.577	0.495	0.369	0.805	1.720
7	0.496	0.597	1.090	0.551	0.496	0.353	0.768	1.724
8	0.496	0.597	1.077	0.525	0.496	0.339	0.739	1.729
9	0.493	0.637	0.991	0.538	0.493	0.415	0.897	1.789
10	0.486	0.724	0.870	0.566	0.486	0.518	1.118	1.722
11	0.480	0.731	0.836	0.554	0.480	0.519	1.131	1.696

RP	PERCENT		INCIDENCE		DEV	D-FACT	EFF	LOSS COEFF		LOSS PARAM	
	SPAN		MEAN	SS				TOT	PROF	TOT	PROF
1	5.00		8.1	5.3	0.4	0.516	0.682	0.307	0.197	0.065	0.041
2	10.00		8.6	5.5	-0.3	0.492	0.734	0.250	0.145	0.053	0.031
3	30.00		10.7	6.6	2.3	0.476	0.766	0.212	0.118	0.042	0.023
4	45.00		11.9	6.9	3.0	0.538	0.737	0.255	0.169	0.050	0.033
5	47.50		12.1	7.0	3.6	0.555	0.727	0.268	0.183	0.052	0.036
6	50.00		12.4	7.1	4.6	0.575	0.713	0.286	0.202	0.055	0.039
7	52.50		12.5	7.1	5.6	0.596	0.698	0.305	0.222	0.058	0.042
8	55.00		12.7	7.2	6.2	0.618	0.688	0.320	0.237	0.060	0.045
9	70.00		13.6	7.3	3.2	0.560	0.767	0.254	0.170	0.052	0.034
10	90.00		14.1	7.0	1.5	0.458	0.924	0.097	0.046	0.020	0.009
11	95.00		14.3	7.0	3.7	0.449	0.917	0.112	0.071	0.022	0.014

TABLE VII. - Continued. BLADE-ELEMENT DATA AT BLADE

EDGES FOR ROTOR 17

(f) 100 Percent of design speed; reading number 1148

RP	RADII		ABS BETAM		REL BETAM		TOTAL TEMP		TOTAL PRESS	
	IN	OUT	IN	OUT	IN	OUT	IN	RATIO	IN	RATIO
1	24.615	24.252	-0.3	49.8	70.3	56.8	289.4	1.252	10.06	1.717
2	24.044	23.716	-0.3	47.0	69.5	55.0	289.3	1.233	10.09	1.719
3	21.720	21.580	-0.3	46.4	66.9	54.3	288.1	1.197	10.14	1.618
4	19.934	19.975	-0.3	50.6	64.8	50.5	287.8	1.194	10.14	1.582
5	19.632	19.708	-0.3	51.7	64.5	50.4	287.6	1.193	10.15	1.568
6	19.329	19.441	-0.3	53.2	64.2	50.4	287.4	1.192	10.15	1.557
7	19.025	19.174	-0.3	55.3	63.8	50.9	287.1	1.190	10.15	1.536
8	18.720	18.908	-0.3	56.7	63.4	50.4	287.9	1.190	10.15	1.527
9	16.858	17.302	-0.3	49.5	60.9	39.6	287.6	1.173	10.15	1.544
10	14.158	15.166	-0.2	44.3	56.7	23.6	287.7	1.160	10.15	1.621
11	13.447	14.630	-0.2	44.7	55.6	20.3	287.6	1.158	10.14	1.605

RP	ABS VEL		REL VEL		MERID VEL		TANG VEL		WHEEL SPEED	
	IN	OUT	IN	OUT	IN	OUT	IN	OUT	IN	OUT
1	148.6	233.7	441.7	275.6	148.6	150.8	-0.7	178.5	415.2	409.1
2	151.5	234.3	433.1	278.6	151.5	159.9	-0.7	171.3	405.0	399.5
3	156.6	216.2	399.3	255.7	156.6	149.1	-0.7	156.6	366.6	364.2
4	158.4	218.5	372.3	217.9	158.4	138.7	-0.7	168.8	336.2	336.9
5	158.3	216.7	367.9	210.8	158.3	134.3	-0.7	170.1	331.3	332.6
6	158.4	215.4	363.4	202.4	158.4	129.1	-0.7	172.4	326.3	328.2
7	157.9	212.3	358.0	191.4	157.9	120.8	-0.7	174.6	320.6	323.1
8	158.3	212.6	353.7	183.2	158.3	116.9	-0.7	177.6	315.6	318.8
9	158.6	224.9	325.8	189.3	158.6	145.9	-0.7	171.1	283.9	291.7
10	157.4	253.0	286.5	197.5	157.4	181.0	-0.7	176.8	238.7	255.7
11	155.7	255.0	275.5	193.2	155.7	181.1	-0.6	179.4	226.6	246.6

RP	ABS MACH NO		REL MACH NO		MERID MACH NO		MERID PEAK SS	
	IN	OUT	IN	OUT	IN	OUT	VEL R	MACH NO
1	0.444	0.637	1.320	0.751	0.444	0.411	1.015	1.699
2	0.453	0.644	1.296	0.766	0.453	0.440	1.056	1.691
3	0.470	0.601	1.199	0.711	0.470	0.415	0.952	1.711
4	0.476	0.609	1.119	0.608	0.476	0.387	0.876	1.729
5	0.476	0.604	1.106	0.588	0.476	0.375	0.848	1.736
6	0.477	0.601	1.093	0.565	0.477	0.360	0.815	1.741
7	0.475	0.593	1.078	0.534	0.475	0.337	0.765	1.746
8	0.476	0.593	1.063	0.511	0.476	0.326	0.738	1.750
9	0.477	0.635	0.980	0.534	0.477	0.412	0.920	1.794
10	0.473	0.726	0.861	0.567	0.473	0.520	1.150	1.725
11	0.468	0.734	0.828	0.556	0.468	0.521	1.164	1.697

RP	PERCENT SPAN		INCIDENCE		DEV	D-FACT	EFF	LOSS COEFF		LOSS PARAM	
	MEAN	SS	MEAN	SS				TOT	PROF	TOT	PROF
1	5.00	8.9	6.1	1.2	0.528	0.664	0.327	0.214	0.068	0.044	
2	10.00	9.3	6.3	-0.0	0.502	0.718	0.269	0.162	0.057	0.034	
3	30.00	11.5	7.3	2.5	0.491	0.747	0.234	0.138	0.046	0.027	
4	45.00	12.7	7.8	3.0	0.555	0.722	0.276	0.188	0.054	0.037	
5	47.50	13.0	7.9	3.9	0.569	0.709	0.292	0.204	0.057	0.039	
6	50.00	13.2	7.9	4.8	0.586	0.701	0.303	0.215	0.058	0.041	
7	52.50	13.4	8.0	6.3	0.611	0.685	0.322	0.236	0.060	0.044	
8	55.00	13.5	8.0	6.8	0.629	0.675	0.337	0.252	0.063	0.047	
9	70.00	14.3	8.0	3.2	0.560	0.762	0.263	0.179	0.053	0.036	
10	90.00	14.7	7.6	1.2	0.453	0.925	0.097	0.047	0.020	0.009	
11	95.00	14.9	7.6	3.4	0.442	0.918	0.113	0.072	0.022	0.014	

TABLE VII. - Continued. BLADE-ELEMENT DATA AT BLADE

EDGES FOR ROTOR 17

(g) 100 Percent of design speed; reading number 1179

RP	RADII		ABS BETAM		REL BETAM		TOTAL TEMP		TOTAL PRESS	
	IN	OUT	IN	OUT	IN	OUT	IN	RATIO	IN	RATIO
1	24.615	24.252	0.0	34.4	64.3	57.4	288.7	1.172	10.07	1.525
2	24.044	23.716	0.0	33.2	63.1	56.3	288.6	1.162	10.13	1.517
3	21.720	21.580	0.0	31.5	60.1	53.1	288.1	1.142	10.13	1.490
4	19.934	19.975	0.0	35.5	57.3	46.7	288.0	1.151	10.14	1.502
5	19.632	19.708	0.0	36.3	56.8	47.2	288.1	1.149	10.14	1.467
6	19.329	19.441	0.0	37.3	56.3	49.8	288.0	1.143	10.14	1.403
7	19.025	19.174	0.0	38.6	55.9	51.2	288.0	1.140	10.14	1.367
8	18.720	18.908	0.0	39.6	55.4	48.6	288.1	1.143	10.14	1.389
9	16.838	17.302	0.0	36.5	52.7	37.9	287.9	1.138	10.14	1.471
10	14.158	15.166	0.0	38.1	48.6	23.0	287.8	1.142	10.15	1.542
11	13.447	14.630	0.0	39.6	47.6	20.5	287.9	1.144	10.14	1.520

RP	ABS VEL		REL VEL		MERID VEL		TANG VEL		WHEEL SPEED	
	IN	OUT	IN	OUT	IN	OUT	IN	OUT	IN	OUT
1	199.4	220.6	460.6	337.7	199.4	182.1	0.0	124.6	415.1	409.0
2	205.1	221.6	454.0	334.2	205.1	185.4	0.0	121.5	405.0	399.5
3	211.1	219.7	423.0	312.0	211.1	187.3	0.0	114.7	366.6	364.3
4	216.3	233.3	400.2	277.4	216.3	190.1	0.0	135.4	336.7	337.4
5	217.0	227.5	396.0	269.9	217.0	183.4	0.0	134.5	331.3	332.6
6	217.3	211.9	392.0	261.3	217.3	168.5	0.0	128.5	326.3	328.2
7	217.5	203.0	387.9	252.9	217.5	158.6	0.0	126.7	321.2	323.7
8	217.6	210.8	383.3	245.5	217.6	162.3	0.0	134.5	315.6	318.8
9	216.6	239.2	357.1	243.5	216.6	192.2	0.0	142.3	283.9	291.7
10	215.2	269.0	318.1	230.1	210.2	211.8	0.0	165.9	238.7	255.8
11	207.2	266.9	307.3	219.5	207.2	205.6	0.0	170.1	226.9	246.9

RP	ABS MACH NO		REL MACH NO		MERID MACH NO		MERID PEAK SS VEL R MACH NO
	IN	OUT	IN	OUT	IN	OUT	
1	0.607	0.621	1.401	0.950	0.607	0.512	0.913 1.571
2	0.626	0.627	1.385	0.945	0.626	0.524	0.904 1.558
3	0.646	0.627	1.294	0.891	0.646	0.535	0.887 1.563
4	0.663	0.667	1.227	0.793	0.663	0.543	0.879 1.559
5	0.665	0.649	1.214	0.771	0.665	0.524	0.845 1.557
6	0.667	0.604	1.203	0.744	0.667	0.480	0.776 1.558
7	0.667	0.577	1.190	0.719	0.667	0.451	0.729 1.558
8	0.667	0.600	1.176	0.699	0.667	0.462	0.746 1.556
9	0.664	0.690	1.095	0.702	0.664	0.554	0.888 1.594
10	0.643	0.784	0.973	0.671	0.643	0.618	1.008 1.675
11	0.633	0.777	0.939	0.639	0.633	0.599	0.992 1.659

RP	PERCENT SPAN	INCIDENCE		DEV	D-FACT	EFF	LOSS COEFF		LOSS PARAM	
		MEAN	SS				TOT	PROF	TOT	PROF
1	5.00	2.9	0.1	1.7	0.368	0.744	0.179	0.083	0.036	0.017
2	10.00	2.9	-0.1	1.3	0.362	0.779	0.150	0.059	0.031	0.012
3	30.00	4.6	0.5	1.3	0.353	0.852	0.098	0.020	0.020	0.004
4	45.00	5.2	0.2	-0.7	0.411	0.817	0.136	0.069	0.029	0.015
5	47.50	5.3	0.2	0.7	0.422	0.774	0.168	0.103	0.035	0.021
6	50.00	5.4	0.1	4.2	0.432	0.712	0.206	0.143	0.040	0.028
7	52.50	5.5	0.1	6.6	0.445	0.669	0.234	0.173	0.043	0.032
8	55.00	5.5	0.0	5.1	0.462	0.687	0.230	0.171	0.044	0.033
9	70.00	6.1	-0.2	1.5	0.424	0.843	0.126	0.071	0.026	0.015
10	90.00	6.7	-0.4	0.6	0.396	0.927	0.073	0.018	0.015	0.004
11	95.00	6.9	-0.4	3.6	0.407	0.884	0.121	0.074	0.024	0.015

TABLE VII. - Continued. BLADE-ELEMENT DATA AT BLADE

EDGES FOR ROTOR 17

(h) 90 Percent of design speed; reading number 1151

RP	RADI		ABS BETAM		REL BETAM		TOTAL TEMP		TOTAL PRESS	
	IN	OUT	IN	OUT	IN	OUT	IN	RATIO	IN	RATIO
1	24.615	24.252	-0.3	25.0	64.2	57.0	288.7	1.109	10.06	1.331
2	24.044	23.716	-0.3	24.4	62.9	56.3	288.6	1.103	10.12	1.318
3	21.720	21.580	-0.3	24.4	59.8	53.0	288.0	1.095	10.13	1.307
4	19.934	19.975	-0.3	28.0	57.1	46.8	288.1	1.104	10.14	1.339
5	19.632	19.708	-0.3	28.5	56.6	46.1	288.0	1.105	10.14	1.337
6	19.329	19.441	-0.3	28.8	56.1	46.4	287.6	1.102	10.14	1.314
7	19.025	19.174	-0.3	29.7	55.6	47.0	288.3	1.102	10.14	1.290
8	18.720	18.908	-0.3	30.8	55.2	45.8	288.1	1.104	10.14	1.291
9	16.838	17.302	-0.3	29.9	52.3	37.1	287.9	1.101	10.15	1.358
10	14.158	15.166	-0.2	33.9	48.3	24.0	287.9	1.108	10.15	1.392
11	13.447	14.630	-0.2	35.4	47.2	20.2	287.8	1.111	10.14	1.408

RP	ABS VEL		REL VEL		MERID VEL		TANG VEL		WHEEL SPEED	
	IN	OUT	IN	OUT	IN	OUT	IN	OUT	IN	OUT
1	181.1	202.5	415.8	336.8	181.1	183.6	-0.9	85.5	373.4	367.9
2	186.7	202.3	410.4	331.9	186.7	184.2	-0.9	83.5	364.6	359.7
3	192.3	201.7	382.4	305.6	192.3	183.7	-0.9	83.3	329.6	327.5
4	196.8	215.1	362.0	277.5	196.8	189.8	-0.9	101.1	302.9	303.5
5	197.4	215.5	358.4	272.9	197.4	189.3	-0.9	102.9	298.3	299.4
6	197.0	209.8	353.6	266.7	197.0	183.8	-0.9	101.2	292.8	294.5
7	198.0	203.8	350.6	259.4	198.0	177.0	-0.9	101.1	288.5	290.8
8	197.8	205.3	346.3	252.8	197.8	176.4	-0.9	105.0	283.3	286.2
9	197.8	227.3	323.5	247.0	197.8	197.1	-0.9	113.3	255.1	262.1
10	192.3	248.5	288.9	225.8	192.3	206.3	-0.8	138.4	214.8	230.1
11	189.6	252.3	279.1	219.2	189.6	205.7	-0.8	146.1	204.0	222.0

RP	ABS MACH NO		REL MACH NO		MERID MACH NO		MERID PEAK SS	
	IN	OUT	IN	OUT	IN	OUT	VEL R	MACH NO
1	0.547	0.583	1.257	0.970	0.547	0.529	1.013	1.430
2	0.566	0.584	1.243	0.959	0.566	0.532	0.987	1.418
3	0.584	0.586	1.162	0.887	0.584	0.533	0.955	1.440
4	0.599	0.624	1.101	0.806	0.599	0.551	0.964	1.454
5	0.601	0.626	1.091	0.792	0.601	0.550	0.959	1.457
6	0.600	0.609	1.077	0.775	0.600	0.534	0.933	1.459
7	0.602	0.590	1.067	0.751	0.602	0.512	0.894	1.462
8	0.602	0.594	1.054	0.732	0.602	0.511	0.892	1.465
9	0.602	0.664	0.985	0.722	0.602	0.576	0.996	1.516
10	0.584	0.730	0.878	0.663	0.584	0.606	1.073	1.500
11	0.576	0.742	0.847	0.644	0.576	0.604	1.085	1.486

RP	PERCENT	INCIDENCE		DEV	D-FACT	EFF	LOSS COEFF		LOSS PARAM	
	SPAN	MEAN	SS				TOT	PROF	TOT	PROF
1	5.00	2.7	-0.1	1.3	0.268	0.780	0.117	0.070	0.024	0.014
2	10.00	2.7	-0.3	1.3	0.267	0.794	0.106	0.063	0.022	0.013
3	30.00	4.4	0.2	1.2	0.274	0.838	0.085	0.048	0.017	0.010
4	45.00	5.0	0.0	-0.6	0.321	0.833	0.102	0.070	0.021	0.015
5	47.50	5.1	-0.0	-0.5	0.327	0.825	0.109	0.078	0.023	0.016
6	50.00	5.2	-0.1	0.9	0.333	0.791	0.129	0.099	0.027	0.020
7	52.50	5.2	-0.2	2.4	0.346	0.744	0.158	0.129	0.032	0.026
8	55.00	5.3	-0.2	2.2	0.359	0.729	0.173	0.145	0.035	0.029
9	70.00	5.8	-0.5	0.7	0.331	0.903	0.068	0.040	0.014	0.008
10	90.00	6.3	-0.8	1.6	0.329	0.919	0.072	0.056	0.015	0.011
11	95.00	6.5	-0.8	3.3	0.330	0.925	0.073	0.061	0.014	0.012

TABLE VII. - Continued. BLADE-ELEMENT DATA AT BLADE

EDGES FOR ROTOR 17

(i) 90 Percent of design speed; reading number 1152

RP	RADII		ABS BETAM		REL BETAM		TOTAL TEMP		TOTAL PRESS	
	IN	OUT	IN	OUT	IN	OUT	IN	RATIO	IN	RATIO
1	24.615	24.252	-0.3	33.5	65.0	56.3	288.8	1.144	10.07	1.453
2	24.044	23.716	-0.3	31.6	63.9	55.6	288.8	1.133	10.11	1.445
3	21.720	21.580	-0.3	31.8	60.9	52.9	288.0	1.118	10.14	1.408
4	19.934	19.975	-0.3	32.7	58.2	47.6	288.0	1.118	10.14	1.419
5	19.632	19.708	-0.3	33.2	57.8	46.5	288.2	1.119	10.14	1.419
6	19.329	19.441	-0.3	34.8	57.4	45.7	287.9	1.121	10.14	1.414
7	19.025	19.174	-0.3	36.2	56.9	45.7	288.1	1.123	10.15	1.393
8	18.720	18.908	-0.3	37.2	56.5	45.0	287.8	1.123	10.15	1.385
9	16.838	17.302	-0.3	35.6	53.8	37.6	287.9	1.115	10.14	1.407
10	14.158	15.166	-0.2	38.9	50.1	24.0	287.8	1.119	10.14	1.429
11	13.447	14.630	-0.2	39.9	49.0	19.4	287.8	1.120	10.13	1.448

RP	ABS VEL		REL VEL		MERID VEL		TANG VEL		WHEEL SPEED	
	IN	OUT	IN	OUT	IN	OUT	IN	OUT	IN	OUT
1	174.7	204.3	412.9	306.8	174.7	170.4	-0.8	112.7	373.3	367.8
2	179.2	203.8	407.5	307.2	179.2	173.6	-0.9	106.8	365.2	360.2
3	183.9	198.3	377.6	279.2	183.9	168.6	-0.8	104.4	329.0	326.9
4	187.8	207.4	356.8	258.7	187.8	174.5	-0.9	112.1	302.4	303.0
5	188.2	209.1	352.9	254.1	188.2	175.0	-0.9	114.5	297.6	298.8
6	188.5	209.2	349.6	246.0	188.5	171.8	-0.9	119.3	293.6	295.3
7	188.7	205.3	345.6	237.2	188.7	165.7	-0.9	121.2	288.7	291.0
8	188.7	204.6	341.8	230.6	188.7	162.9	-0.8	123.8	284.1	287.0
9	187.2	217.2	317.2	222.9	187.2	176.7	-0.8	126.4	255.3	262.3
10	180.5	236.1	281.1	201.3	180.5	183.8	-0.7	148.1	214.8	230.1
11	177.8	243.3	271.0	197.9	177.8	186.7	-0.7	156.1	203.8	221.7

RP	ABS MACH NO		REL MACH NO		MERID MACH NO		MERID PEAK SS	
	IN	OUT	IN	OUT	IN	OUT	VEL R	MACH NO
1	0.527	0.579	1.245	0.870	0.527	0.483	0.976	1.447
2	0.541	0.581	1.231	0.875	0.541	0.495	0.969	1.441
3	0.557	0.569	1.144	0.801	0.557	0.484	0.917	1.462
4	0.570	0.597	1.082	0.744	0.570	0.502	0.929	1.482
5	0.571	0.602	1.070	0.731	0.571	0.503	0.930	1.485
6	0.572	0.602	1.061	0.707	0.572	0.494	0.912	1.492
7	0.572	0.589	1.049	0.681	0.572	0.475	0.878	1.496
8	0.573	0.587	1.037	0.662	0.573	0.468	0.863	1.503
9	0.568	0.628	0.962	0.645	0.568	0.511	0.943	1.531
10	0.546	0.687	0.851	0.585	0.546	0.535	1.018	1.506
11	0.538	0.709	0.820	0.577	0.538	0.544	1.050	1.487

RP	PERCENT		INCIDENCE		DEV	D-FACT	EFF	LOSS COEFF		LOSS PARAM	
	SPAN	MEAN	SS	TOT				PROF	TOT	PROF	
1	5.00	3.5	0.7	0.6	0.360	0.781	0.150	0.101	0.031	0.021	
2	10.00	3.7	0.7	0.6	0.343	0.834	0.109	0.063	0.023	0.013	
3	30.00	5.4	1.3	1.0	0.354	0.871	0.083	0.045	0.017	0.009	
4	45.00	6.1	1.2	0.1	0.373	0.890	0.077	0.043	0.016	0.009	
5	47.50	6.2	1.1	-0.1	0.380	0.883	0.084	0.051	0.018	0.011	
6	50.00	6.4	1.2	0.1	0.400	0.861	0.102	0.069	0.021	0.014	
7	52.50	6.5	1.1	1.1	0.418	0.810	0.142	0.110	0.029	0.023	
8	55.00	6.6	1.1	1.5	0.432	0.794	0.156	0.124	0.032	0.026	
9	70.00	7.3	1.0	1.2	0.404	0.894	0.086	0.058	0.018	0.012	
10	90.00	8.1	1.0	1.7	0.405	0.904	0.097	0.083	0.020	0.017	
11	95.00	8.3	1.0	2.5	0.397	0.927	0.080	0.076	0.016	0.014	

TABLE VII. - Continued. BLADE-ELEMENT DATA AT BLADE

EDGES FOR ROTOR 17

(j) 90 Percent of design speed; reading number 1153

RP	RADII		ABS BETAM		REL BETAM		TOTAL TEMP		TOTAL PRESS	
	IN	OUT	IN	OUT	IN	OUT	IN	RATIO	IN	RATIO
1	24.615	24.252	-0.3	37.8	66.6	55.6	289.0	1.169	10.06	1.525
2	24.044	23.716	-0.3	37.1	65.5	54.7	289.0	1.154	10.10	1.516
3	21.720	21.580	-0.3	35.7	62.6	52.9	288.0	1.131	10.14	1.461
4	19.934	19.975	-0.3	36.7	60.2	48.6	288.0	1.128	10.15	1.446
5	19.632	19.708	-0.3	37.8	59.8	47.7	287.8	1.128	10.15	1.444
6	19.329	19.441	-0.3	38.8	59.5	46.7	287.9	1.130	10.14	1.442
7	19.025	19.174	-0.3	41.1	59.1	46.8	287.9	1.131	10.15	1.418
8	18.720	18.908	-0.3	42.4	58.7	46.5	287.8	1.132	10.15	1.406
9	16.838	17.302	-0.3	42.3	56.3	38.6	287.8	1.126	10.15	1.412
10	14.158	15.166	-0.2	41.8	52.7	23.1	287.7	1.126	10.15	1.468
11	13.447	14.630	-0.2	42.3	51.8	19.9	287.8	1.125	10.13	1.465

RP	ABS VEL		REL VEL		MERID VEL		TANG VEL		WHEEL SPEED	
	IN	OUT	IN	OUT	IN	OUT	IN	OUT	IN	OUT
1	162.1	208.1	407.9	291.4	162.1	164.5	-0.8	127.4	373.5	368.0
2	166.1	207.9	401.1	286.8	166.1	165.8	-0.8	125.4	364.3	359.4
3	171.3	197.4	372.2	265.9	171.3	160.2	-0.8	115.3	329.6	327.5
4	173.5	201.1	349.5	243.9	173.5	161.2	-0.8	120.2	302.6	303.2
5	173.8	201.9	345.6	237.1	173.8	159.6	-0.8	123.7	297.9	299.1
6	173.6	203.2	341.9	231.0	173.6	158.4	-0.8	127.2	293.7	295.4
7	173.0	198.9	336.9	219.2	173.0	149.9	-0.8	130.7	288.3	290.6
8	173.2	197.6	333.3	211.7	173.2	145.8	-0.8	133.3	284.0	286.8
9	170.7	207.5	307.8	196.3	170.7	153.3	-0.8	139.7	255.3	262.3
10	164.5	233.9	271.2	189.5	164.5	174.4	-0.7	155.9	214.9	230.2
11	161.7	236.5	261.2	186.2	161.7	175.1	-0.7	159.1	204.5	222.5

RP	ABS MACH NO		REL MACH NO		MERID MACH NO		MERID PEAK SS	
	IN	OUT	IN	OUT	IN	OUT	VEL R	MACH NO
1	0.487	0.584	1.225	0.818	0.487	0.461	1.015	1.484
2	0.499	0.587	1.206	0.810	0.499	0.468	0.999	1.476
3	0.517	0.563	1.123	0.758	0.517	0.457	0.936	1.506
4	0.524	0.575	1.055	0.697	0.524	0.461	0.929	1.534
5	0.525	0.577	1.044	0.678	0.525	0.456	0.918	1.540
6	0.524	0.581	1.032	0.660	0.524	0.453	0.912	1.550
7	0.522	0.567	1.017	0.625	0.522	0.428	0.867	1.558
8	0.523	0.563	1.007	0.603	0.523	0.416	0.842	1.567
9	0.515	0.595	0.929	0.563	0.515	0.440	0.898	1.555
10	0.496	0.678	0.817	0.549	0.496	0.505	1.060	1.519
11	0.487	0.686	0.786	0.540	0.487	0.508	1.082	1.503

RP	PERCENT	INCIDENCE		DEV	D-FACT	EFF	LOSS COEFF		LOSS PARAM	
	SPAN	MEAN	SS				TOT	PROF	TOT	PROF
1	5.00	5.1	2.3	-0.0	0.403	0.759	0.190	0.138	0.040	0.029
2	10.00	5.3	2.3	-0.3	0.400	0.819	0.137	0.089	0.029	0.019
3	30.00	7.2	3.0	1.1	0.390	0.872	0.093	0.050	0.019	0.010
4	45.00	8.1	3.2	1.2	0.409	0.871	0.100	0.061	0.020	0.012
5	47.50	8.3	3.2	1.2	0.424	0.864	0.106	0.068	0.022	0.014
6	50.00	8.5	3.3	1.1	0.437	0.849	0.122	0.083	0.025	0.017
7	52.50	8.7	3.3	2.3	0.465	0.798	0.166	0.128	0.034	0.026
8	55.00	8.8	3.3	2.9	0.483	0.774	0.189	0.150	0.038	0.030
9	70.00	9.8	3.5	2.3	0.484	0.820	0.165	0.137	0.034	0.028
10	90.00	10.7	3.6	0.7	0.434	0.923	0.087	0.074	0.018	0.015
11	95.00	11.1	3.8	3.0	0.421	0.920	0.096	0.087	0.019	0.017

TABLE VII. - Continued. BLADE-ELEMENT DATA AT BLADE

EDGES FOR ROTOR 17

(k) 90 Percent of design speed; reading number 1154

RP	RADII		ABS. BETAM		REL BETAM		TOTAL TEMP		TOTAL PRESS	
	IN	OUT	IN	OUT	IN	OUT	IN	RATIO	IN	RATIO
1	24.615	24.252	-0.3	41.5	68.3	55.6	289.7	1.181	10.07	1.546
2	24.044	23.716	-0.3	40.2	67.4	54.2	289.3	1.169	10.11	1.548
3	21.720	21.580	-0.3	38.5	64.5	53.6	287.9	1.140	10.14	1.464
4	19.934	19.975	-0.3	42.8	62.4	49.7	287.8	1.139	10.14	1.442
5	19.632	19.708	-0.3	43.7	62.1	48.9	287.7	1.140	10.14	1.439
6	19.329	19.441	-0.3	45.5	61.7	48.4	287.8	1.141	10.14	1.431
7	19.025	19.174	-0.3	47.3	61.4	48.4	287.7	1.142	10.15	1.414
8	18.720	18.908	-0.3	49.3	61.1	47.9	287.7	1.142	10.14	1.405
9	16.858	17.302	-0.3	45.9	58.6	38.3	287.7	1.135	10.15	1.424
10	14.158	15.166	-0.2	42.2	54.7	23.3	287.6	1.127	10.15	1.482
11	13.447	14.630	-0.2	42.8	53.6	20.4	287.7	1.125	10.13	1.469

RP	ABS VEL		REL VEL		MERID VEL		TANG VEL		WHEEL SPEED	
	IN	OUT	IN	OUT	IN	OUT	IN	OUT	IN	OUT
1	148.9	209.9	403.2	278.2	148.9	157.2	-0.7	139.0	374.0	368.5
2	152.2	211.2	396.2	275.9	152.2	161.4	-0.7	136.3	365.1	360.1
3	157.5	194.1	365.6	256.2	157.5	151.9	-0.7	120.8	329.2	327.1
4	158.6	196.6	342.7	223.1	158.6	144.3	-0.7	133.6	303.1	303.7
5	158.5	197.1	338.4	216.6	158.5	142.4	-0.7	136.3	298.2	299.4
6	158.4	196.7	334.4	207.6	158.4	137.9	-0.7	140.3	293.7	295.4
7	157.8	194.2	329.7	198.2	157.8	131.6	-0.7	142.8	288.8	291.0
8	157.5	194.1	325.5	188.7	157.5	126.6	-0.7	147.1	284.1	287.0
9	156.2	207.1	300.1	183.7	156.2	144.1	-0.7	148.7	255.6	262.6
10	152.8	232.3	264.3	187.5	152.8	172.2	-0.7	156.0	215.0	230.3
11	151.0	233.2	254.5	182.4	151.0	170.9	-0.6	158.6	204.3	222.3

RP	ABS MACH NO		REL MACH NO		MERID MACH NO		MERID PEAK SS	
	IN	OUT	IN	OUT	IN	OUT	VEL R	SS MACH NO
1	0.445	0.585	1.205	0.776	0.445	0.438	1.056	1.527
2	0.456	0.593	1.186	0.774	0.456	0.453	1.060	1.523
3	0.473	0.550	1.099	0.727	0.473	0.431	0.965	1.554
4	0.477	0.558	1.031	0.634	0.477	0.410	0.910	1.598
5	0.477	0.560	1.018	0.615	0.477	0.404	0.899	1.607
6	0.476	0.558	1.005	0.589	0.476	0.391	0.871	1.617
7	0.474	0.550	0.991	0.562	0.474	0.373	0.834	1.618
8	0.474	0.550	0.979	0.535	0.474	0.359	0.804	1.611
9	0.469	0.591	0.902	0.525	0.469	0.412	0.923	1.583
10	0.459	0.672	0.794	0.543	0.459	0.498	1.126	1.532
11	0.453	0.675	0.764	0.528	0.453	0.495	1.132	1.511

RP	PERCENT		INCIDENCE		DEV	D-FACT	EFF	LOSS COEFF		LOSS PARAM	
	SPAN	MEAN	SS	SS				TOT	PROF	TOT	PROF
1	5.00	6.9	4.1	-0.1	0.440	0.734	0.225	0.168	0.048	0.036	
2	10.00	7.2	4.2	-0.8	0.430	0.789	0.174	0.120	0.038	0.026	
3	30.00	9.1	4.9	1.8	0.410	0.822	0.139	0.091	0.028	0.018	
4	45.00	10.4	5.4	2.3	0.470	0.793	0.175	0.127	0.035	0.025	
5	47.50	10.5	5.4	2.3	0.484	0.785	0.186	0.138	0.037	0.028	
6	50.00	10.7	5.5	2.8	0.506	0.763	0.210	0.162	0.042	0.032	
7	52.50	11.0	5.6	3.8	0.528	0.732	0.241	0.196	0.047	0.038	
8	55.00	11.2	5.7	4.3	0.553	0.717	0.260	0.217	0.051	0.042	
9	70.00	12.1	5.8	2.0	0.520	0.790	0.210	0.181	0.043	0.037	
10	90.00	12.7	5.6	1.0	0.426	0.941	0.071	0.059	0.014	0.012	
11	95.00	12.9	5.6	3.5	0.421	0.928	0.090	0.082	0.018	0.016	

TABLE VII. - Continued. BLADE-ELEMENT DATA AT BLADE

EDGES FOR ROTOR 17

(1) 90 Percent of design speed; reading number 1155

RP	RADII		ABS BETAM		REL BETAM		TOTAL TEMP		TOTAL PRESS	
	IN	OUT	IN	OUT	IN	OUT	IN	RATIO	IN	RATIO
1	24.615	24.252	-0.3	44.8	70.1	56.7	290.3	1.180	10.06	1.538
2	24.044	23.716	-0.3	43.1	69.1	55.3	289.7	1.172	10.11	1.536
3	21.720	21.580	-0.3	43.0	66.3	54.5	287.9	1.150	10.14	1.460
4	19.934	19.975	-0.3	47.7	64.4	50.0	287.6	1.151	10.14	1.445
5	19.632	19.708	-0.3	49.0	64.0	49.5	287.6	1.151	10.15	1.440
6	19.329	19.441	-0.3	50.3	63.7	49.8	287.5	1.150	10.14	1.426
7	19.025	19.174	-0.3	51.9	63.4	49.8	287.5	1.149	10.15	1.414
8	18.720	18.908	-0.3	53.5	63.0	49.2	287.6	1.149	10.15	1.408
9	16.838	17.302	-0.3	47.5	60.5	38.5	287.5	1.139	10.15	1.431
10	14.158	15.166	-0.2	42.4	56.3	23.7	287.5	1.127	10.15	1.490
11	13.447	14.630	-0.2	43.3	55.2	20.8	287.5	1.126	10.14	1.470

RP	ABS VEL		REL VEL		MERID VEL		TANG VEL		WHEEL SPEED	
	IN	OUT	IN	OUT	IN	OUT	IN	OUT	IN	OUT
1	135.6	206.5	398.4	266.7	135.6	146.4	-0.7	145.6	373.9	368.4
2	139.8	207.4	391.7	266.0	139.8	151.5	-0.7	141.6	365.2	360.2
3	144.8	191.9	361.0	241.7	144.8	140.3	-0.7	131.0	329.9	327.8
4	145.6	196.8	336.4	205.9	145.6	132.5	-0.7	145.6	302.6	303.2
5	145.4	196.6	332.2	198.6	145.4	129.1	-0.7	148.3	298.0	299.2
6	145.5	193.9	328.5	191.8	145.5	123.9	-0.7	149.1	293.8	295.5
7	145.3	192.1	324.2	183.8	145.3	118.6	-0.7	151.1	289.1	291.4
8	145.2	192.3	319.9	175.2	145.2	114.4	-0.7	154.6	284.4	287.2
9	145.2	206.3	294.7	178.1	145.2	139.5	-0.7	152.1	255.8	262.9
10	143.8	230.6	259.1	185.8	143.8	170.1	-0.6	155.6	214.9	230.2
11	142.1	230.7	249.1	179.5	142.1	167.8	-0.6	158.2	204.0	221.9

RP	ABS MACH NO		REL MACH NO		MERID MACH NO		MERID PEAK SS	
	IN	OUT	IN	OUT	IN	OUT	VEL R	MACH NO
1	0.404	0.575	1.185	0.742	0.404	0.408	1.080	1.570
2	0.417	0.580	1.168	0.744	0.417	0.424	1.084	1.565
3	0.434	0.542	1.081	0.682	0.434	0.396	0.969	1.606
4	0.436	0.556	1.008	0.582	0.436	0.374	0.910	1.656
5	0.436	0.556	0.996	0.561	0.436	0.365	0.888	1.663
6	0.436	0.548	0.985	0.542	0.436	0.350	0.851	1.658
7	0.436	0.542	0.972	0.519	0.436	0.335	0.816	1.651
8	0.435	0.543	0.959	0.495	0.435	0.323	0.788	1.642
9	0.435	0.588	0.883	0.508	0.435	0.398	0.961	1.606
10	0.431	0.667	0.776	0.537	0.431	0.492	1.183	1.544
11	0.426	0.668	0.746	0.519	0.426	0.486	1.181	1.519

RP	PERCENT		INCIDENCE		DEV	D-FACT	EFF	LOSS COEFF		LOSS PARAM	
	SPAN	MEAN	SS	SS				TOT	PROF	TOT	PROF
1	5.00	8.6	5.8	1.1	0.468	0.729	0.232	0.169	0.048	0.035	
2	10.00	8.9	5.9	0.3	0.454	0.759	0.204	0.145	0.043	0.030	
3	30.00	10.9	6.8	2.7	0.452	0.763	0.199	0.143	0.039	0.028	
4	45.00	12.3	7.3	2.5	0.522	0.737	0.243	0.187	0.048	0.037	
5	47.50	12.5	7.4	2.9	0.539	0.729	0.254	0.199	0.050	0.039	
6	50.00	12.7	7.5	4.2	0.553	0.712	0.273	0.220	0.053	0.043	
7	52.50	12.9	7.6	5.2	0.572	0.696	0.292	0.242	0.056	0.046	
8	55.00	13.1	7.6	5.7	0.594	0.689	0.303	0.257	0.058	0.049	
9	70.00	13.9	7.7	2.1	0.534	0.777	0.236	0.205	0.049	0.042	
10	90.00	14.3	7.2	1.3	0.421	0.947	0.066	0.054	0.013	0.011	
11	95.00	14.5	7.2	3.9	0.419	0.926	0.096	0.088	0.019	0.017	

TABLE VII. - Continued. BLADE-ELEMENT DATA AT BLADE

EDGES FOR ROTOR 17

(m) 90 Percent of design speed; reading number 1156

RP	RADI I		ABS BETAM		REL BETAM		TOTAL TEMP		TOTAL PRESS	
	IN	OUT	IN	OUT	IN	OUT	IN	RATIO	IN	RATIO
1	24.615	24.252	-0.3	54.6	72.6	59.5	291.1	1.201	10.05	1.525
2	24.044	23.716	-0.3	49.7	71.6	57.2	290.3	1.190	10.10	1.521
3	21.720	21.580	-0.3	49.6	68.7	55.3	287.8	1.165	10.14	1.463
4	19.934	19.975	-0.3	52.1	66.8	50.3	287.4	1.161	10.15	1.450
5	19.632	19.708	-0.3	52.7	66.5	50.3	287.5	1.160	10.15	1.442
6	19.329	19.441	-0.3	53.8	66.1	50.5	287.4	1.159	10.15	1.430
7	19.025	19.174	-0.3	55.3	65.7	50.8	287.4	1.157	10.15	1.418
8	18.720	18.908	-0.3	56.6	65.4	50.6	287.3	1.155	10.15	1.410
9	16.858	17.302	-0.3	48.9	62.6	37.6	287.3	1.144	10.15	1.445
10	14.158	15.166	-0.2	42.7	58.2	24.1	287.3	1.129	10.15	1.494
11	13.447	14.630	-0.2	43.6	57.2	20.9	287.3	1.127	10.14	1.479

RP	ABS VEL		REL VEL		MERID VEL		TANG VEL		WHEEL SPEED	
	IN	OUT	IN	OUT	IN	OUT	IN	OUT	IN	OUT
1	117.3	204.8	392.2	233.7	117.3	118.8	-0.6	166.9	373.6	368.1
2	122.1	204.1	385.8	243.5	122.1	131.9	-0.6	155.7	365.4	360.4
3	128.8	193.1	354.8	219.9	128.8	125.2	-0.6	147.0	330.0	327.9
4	129.8	198.0	329.5	190.7	129.8	121.7	-0.6	156.1	302.3	302.9
5	130.1	196.3	325.9	186.1	130.1	118.9	-0.6	156.2	298.2	299.3
6	130.3	193.9	321.8	179.9	130.3	114.4	-0.6	156.5	293.6	295.3
7	130.7	191.7	317.8	172.8	130.7	109.3	-0.6	157.5	289.1	291.4
8	130.9	191.1	313.8	165.5	130.9	105.1	-0.6	159.6	284.7	287.5
9	133.0	208.6	288.8	173.2	133.0	137.2	-0.6	157.1	255.7	262.8
10	133.5	228.7	253.5	184.0	133.5	167.9	-0.6	155.2	215.0	230.3
11	131.8	230.1	243.6	178.2	131.8	166.5	-0.6	158.8	204.3	222.3

RP	ABS MACH NO		REL MACH NO		MERID MACH NO		MERID PEAK SS	
	IN	OUT	IN	OUT	IN	OUT	VEL R	MACH NO
1	0.347	0.564	1.160	0.643	0.347	0.327	1.013	1.636
2	0.362	0.565	1.144	0.674	0.362	0.365	1.081	1.631
3	0.384	0.541	1.059	0.616	0.384	0.351	0.972	1.673
4	0.388	0.557	0.984	0.537	0.388	0.343	0.938	1.711
5	0.389	0.552	0.973	0.524	0.389	0.334	0.913	1.706
6	0.389	0.545	0.961	0.506	0.389	0.322	0.878	1.697
7	0.390	0.540	0.949	0.486	0.390	0.307	0.836	1.689
8	0.391	0.538	0.938	0.466	0.391	0.296	0.803	1.682
9	0.397	0.594	0.863	0.493	0.397	0.391	1.032	1.633
10	0.399	0.661	0.758	0.531	0.399	0.485	1.258	1.561
11	0.394	0.665	0.728	0.515	0.394	0.482	1.263	1.537

RP	PERCENT SPAN	INCIDENCE		DEV	D-FACT	EFF	LOSS COEFF		LOSS PARAM	
		MEAN	SS				TOT	PROF	TOT	PROF
1	5.00	11.2	8.4	3.8	0.564	0.638	0.340	0.267	0.065	0.051
2	10.00	11.4	8.3	2.2	0.517	0.670	0.304	0.235	0.061	0.047
3	30.00	13.3	9.2	3.5	0.519	0.695	0.280	0.214	0.053	0.041
4	45.00	14.7	9.8	2.9	0.568	0.695	0.304	0.240	0.060	0.047
5	47.50	14.9	9.8	3.8	0.576	0.687	0.316	0.254	0.061	0.049
6	50.00	15.1	9.9	4.9	0.588	0.678	0.328	0.270	0.063	0.052
7	52.50	15.3	9.9	6.2	0.604	0.669	0.340	0.285	0.064	0.053
8	55.00	15.5	10.0	7.0	0.622	0.665	0.346	0.295	0.064	0.054
9	70.00	16.0	9.8	1.3	0.546	0.769	0.260	0.227	0.054	0.047
10	90.00	16.3	9.1	1.7	0.415	0.944	0.073	0.060	0.015	0.012
11	95.00	16.5	9.3	4.0	0.412	0.930	0.097	0.089	0.019	0.017

TABLE VII. - Continued. BLADE-ELEMENT DATA AT BLADE

EDGES FOR ROTOR 17

(n) 80 Percent of design speed; reading number 1157

RP	RADII		ABS BETAM		REL BETAM		TOTAL TEMP		TOTAL PRESS	
	IN	OUT	IN	OUT	IN	OUT	IN	RATIO	IN	RATIO
1	24.615	24.252	-0.3	54.6	72.7	59.8	289.9	1.161	10.09	1.393
2	24.044	23.716	-0.3	48.9	71.7	57.8	289.1	1.150	10.13	1.387
3	21.720	21.580	-0.3	47.9	68.9	55.2	287.9	1.128	10.13	1.355
4	19.934	19.975	-0.3	49.3	66.9	49.5	287.7	1.124	10.14	1.354
5	19.632	19.708	-0.3	49.8	66.6	49.0	287.9	1.123	10.14	1.351
6	19.329	19.441	-0.3	50.9	66.2	49.3	287.7	1.122	10.14	1.340
7	19.025	19.174	-0.3	52.3	65.8	49.1	287.8	1.121	10.14	1.332
8	18.720	18.908	-0.3	53.7	65.4	48.7	287.8	1.120	10.14	1.326
9	16.838	17.302	-0.3	48.0	62.7	36.9	287.7	1.113	10.14	1.350
10	14.158	15.166	-0.2	42.7	58.5	23.7	287.7	1.102	10.14	1.384
11	13.447	14.630	-0.2	43.5	57.5	21.1	287.7	1.100	10.13	1.367

RP	ABS VEL		REL VEL		MERID VEL		TANG VEL		WHEEL SPEED	
	IN	OUT	IN	OUT	IN	OUT	IN	OUT	IN	OUT
1	103.4	180.5	348.1	208.2	103.4	104.7	-0.5	147.1	331.9	327.0
2	107.9	178.4	343.1	220.1	107.9	117.2	-0.5	134.4	325.2	320.7
3	113.5	170.9	315.0	200.4	113.5	114.5	-0.5	126.9	293.3	291.4
4	114.9	177.2	293.0	177.7	114.9	115.4	-0.5	134.4	269.0	269.5
5	115.3	176.7	289.7	173.9	115.3	114.0	-0.5	134.9	265.2	266.2
6	115.4	174.1	285.9	168.2	115.4	109.7	-0.5	135.1	261.1	262.6
7	115.6	172.8	282.1	161.6	115.6	105.8	-0.5	136.7	256.8	258.8
8	115.7	172.4	278.3	154.6	115.7	102.0	-0.5	138.9	252.5	255.1
9	117.4	187.1	256.0	156.5	117.4	125.1	-0.5	139.2	226.9	233.2
10	117.4	204.5	224.7	164.1	117.4	150.2	-0.5	138.8	191.2	204.8
11	116.0	204.0	215.9	158.6	116.0	147.9	-0.5	140.5	181.6	197.6

RP	ABS MACH NO		REL MACH NO		MERID MACH NO		MERID PEAK SS	
	IN	OUT	IN	OUT	IN	OUT	VEL R	MACH NO
1	0.306	0.503	1.030	0.580	0.306	0.292	1.013	1.559
2	0.320	0.500	1.017	0.617	0.320	0.329	1.087	1.562
3	0.338	0.484	0.937	0.568	0.338	0.324	1.008	1.553
4	0.342	0.504	0.872	0.505	0.342	0.328	1.004	1.518
5	0.343	0.502	0.862	0.494	0.343	0.324	0.989	1.513
6	0.343	0.495	0.851	0.478	0.343	0.312	0.951	1.505
7	0.344	0.492	0.839	0.460	0.344	0.301	0.915	1.496
8	0.344	0.490	0.828	0.440	0.344	0.290	0.882	1.487
9	0.349	0.536	0.762	0.449	0.349	0.359	1.066	1.445
10	0.349	0.593	0.669	0.476	0.349	0.436	1.280	1.385
11	0.345	0.592	0.643	0.460	0.345	0.429	1.275	1.362

RP	PERCENT SPAN	INCIDENCE		DEV	D-FACT	EFF	LOSS COEFF		LOSS PARAM	
		MEAN	SS				TOT	PROF	TOT	PROF
1	5.00	11.3	8.5	4.2	0.561	0.615	0.351	0.311	0.067	0.059
2	10.00	11.5	8.4	2.8	0.503	0.653	0.306	0.267	0.060	0.052
3	30.00	13.5	9.3	3.3	0.499	0.710	0.254	0.225	0.049	0.043
4	45.00	14.8	9.9	2.1	0.536	0.730	0.258	0.241	0.052	0.048
5	47.50	15.0	9.9	2.5	0.542	0.728	0.263	0.248	0.053	0.049
6	50.00	15.2	10.0	3.7	0.555	0.714	0.279	0.265	0.055	0.052
7	52.50	15.4	10.0	4.5	0.571	0.707	0.289	0.277	0.056	0.054
8	55.00	15.5	10.0	5.1	0.591	0.698	0.302	0.292	0.058	0.056
9	70.00	16.2	9.9	0.6	0.534	0.791	0.230	0.227	0.048	0.048
10	90.00	16.6	9.4	1.3	0.412	0.956	0.056	0.056	0.011	0.011
11	95.00	16.8	9.5	4.2	0.409	0.931	0.094	0.094	0.018	0.018

TABLE VII. - Continued. BLADE-ELEMENT DATA AT BLADE

EDGES FOR ROTOR 17

(a) 70 Percent of design speed; reading number 1173

RP	RADI		ABS BETAM		REL BETAM		TOTAL TEMP		TOTAL PRESS	
	IN	OUT	IN	OUT	IN	OUT	IN	RATIO	IN	RATIO
1	24.615	24.252	0.0	21.0	64.6	57.3	288.6	1.054	10.08	1.165
2	24.044	23.716	0.0	20.5	63.4	56.4	288.4	1.051	10.13	1.161
3	21.720	21.580	-0.0	21.1	60.3	53.0	288.1	1.048	10.13	1.164
4	19.934	19.975	0.0	22.9	57.7	49.1	288.1	1.050	10.14	1.168
5	19.632	19.708	0.0	23.2	57.2	48.1	288.2	1.051	10.14	1.170
6	19.329	19.441	0.0	24.6	56.8	46.6	288.1	1.053	10.14	1.169
7	19.025	19.174	0.0	26.3	56.4	45.7	288.1	1.055	10.14	1.165
8	18.720	18.908	0.0	27.8	55.9	44.6	288.2	1.058	10.14	1.169
9	16.838	17.302	0.0	27.5	53.2	37.4	287.9	1.057	10.14	1.195
10	14.158	15.166	-0.0	32.2	49.1	24.1	287.9	1.066	10.14	1.223
11	13.447	14.630	-0.0	33.8	47.8	19.1	288.0	1.068	10.13	1.239

RP	ABS VEL		REL VEL		MERID VEL		TANG VEL		WHEEL SPEED	
	IN	OUT	IN	OUT	IN	OUT	IN	OUT	IN	OUT
1	138.1	158.2	322.1	273.5	138.1	147.8	0.0	56.6	291.0	286.7
2	142.1	159.3	317.4	269.4	142.1	149.2	0.0	55.7	283.8	279.9
3	146.6	159.6	295.5	247.2	146.6	148.8	-0.0	57.6	256.6	254.9
4	149.8	163.4	280.1	229.7	149.8	150.5	0.0	63.7	236.7	237.2
5	150.1	164.9	277.3	227.0	150.1	151.6	0.0	65.1	233.2	234.1
6	148.3	165.4	270.6	218.7	148.3	150.3	0.0	68.9	226.3	227.6
7	147.9	164.7	267.1	211.5	147.9	147.7	0.0	72.8	222.5	224.3
8	149.9	167.0	267.4	207.6	149.9	147.8	0.0	77.8	221.4	223.6
9	148.9	179.4	248.7	200.3	148.9	159.1	0.0	82.9	199.2	204.7
10	145.8	197.9	222.8	183.4	145.8	167.4	-0.0	105.6	168.5	180.5
11	144.0	204.6	214.3	179.9	144.0	170.0	-0.0	113.8	158.7	172.6

RP	ABS MACH NO		REL MACH NO		MERID MACH NO		MERID PEAK SS	
	IN	OUT	IN	OUT	IN	OUT	VEL R	MACH NO
1	0.412	0.462	0.962	0.799	0.412	0.431	1.070	1.218
2	0.425	0.466	0.949	0.788	0.425	0.437	1.050	1.204
3	0.439	0.468	0.885	0.725	0.439	0.437	1.015	1.207
4	0.449	0.479	0.840	0.674	0.449	0.442	1.005	1.199
5	0.450	0.484	0.831	0.666	0.450	0.444	1.010	1.196
6	0.444	0.485	0.811	0.641	0.444	0.441	1.014	1.175
7	0.443	0.482	0.800	0.619	0.443	0.432	0.999	1.171
8	0.449	0.488	0.801	0.607	0.449	0.432	0.986	1.180
9	0.446	0.527	0.746	0.588	0.446	0.467	1.068	1.171
10	0.437	0.582	0.667	0.540	0.437	0.493	1.148	1.160
11	0.431	0.603	0.642	0.530	0.431	0.501	1.180	1.137

RP	PERCENT		INCIDENCE		DEV	D-FACT	EFF	LOSS COEFF		LOSS PARAM	
	SPAN	MEAN	SS	SS				TOT	PROF	TOT	PROF
1	5.00	3.1	0.3	1.7	0.217	0.821	0.070	0.069	0.014	0.014	
2	10.00	3.2	0.1	1.4	0.216	0.851	0.057	0.056	0.012	0.011	
3	30.00	4.8	0.7	1.2	0.228	0.921	0.031	0.031	0.006	0.006	
4	45.00	5.6	0.6	1.6	0.250	0.907	0.042	0.042	0.008	0.008	
5	47.50	5.7	0.6	1.6	0.253	0.902	0.045	0.045	0.009	0.009	
6	50.00	5.8	0.6	1.0	0.268	0.865	0.067	0.067	0.014	0.014	
7	52.50	6.0	0.6	1.1	0.289	0.809	0.101	0.101	0.021	0.021	
8	55.00	6.0	0.5	1.1	0.309	0.786	0.118	0.118	0.024	0.024	
9	70.00	6.7	0.4	1.1	0.283	0.910	0.056	0.056	0.012	0.012	
10	90.00	7.2	0.1	1.8	0.286	0.904	0.082	0.082	0.017	0.017	
11	95.00	7.1	-0.2	2.2	0.277	0.931	0.065	0.065	0.013	0.013	

TABLE VII. - Continued. BLADE-ELEMENT DATA AT BLADE

EDGE FOR ROTOR 17

(p) 70 Percent of design speed; reading number 1174

RP	RADI I		ABS BETAM		REL BETAM		TOTAL TEMP		TOTAL PRESS	
	IN	OUT	IN	OUT	IN	OUT	IN	RATIO	IN	RATIO
1	24.615	24.252	0.0	29.2	66.3	57.0	288.5	1.074	10.10	1.228
2	24.044	23.716	0.0	28.0	65.2	56.2	288.4	1.070	10.13	1.224
3	21.720	21.580	0.0	28.2	62.3	53.1	288.2	1.063	10.13	1.216
4	19.934	19.975	0.0	30.3	59.9	49.6	288.1	1.063	10.13	1.208
5	19.632	19.708	0.0	30.8	59.6	48.5	287.8	1.064	10.14	1.209
6	19.329	19.441	0.0	32.1	59.1	46.7	288.3	1.066	10.14	1.216
7	19.025	19.174	0.0	34.1	58.8	46.7	287.9	1.068	10.14	1.204
8	18.720	18.908	0.0	35.7	58.4	45.9	288.2	1.069	10.14	1.200
9	16.838	17.302	0.0	34.9	55.9	38.2	288.0	1.067	10.14	1.217
10	14.158	15.166	0.0	37.4	52.0	22.6	287.9	1.072	10.14	1.254
11	13.447	14.630	0.0	38.3	51.1	19.2	287.9	1.072	10.13	1.257

RP	ABS VEL		REL VEL		MERID VEL		TANG VEL		WHEEL SPEED	
	IN	OUT	IN	OUT	IN	OUT	IN	OUT	IN	OUT
1	128.0	156.5	318.1	251.0	128.0	136.6	0.0	76.3	291.2	286.9
2	130.8	156.4	312.4	248.3	130.8	138.0	0.0	73.4	283.7	279.8
3	135.0	155.0	290.2	227.5	135.0	136.6	0.0	73.3	256.9	255.2
4	136.5	155.7	272.6	207.3	136.5	134.5	0.0	78.6	235.9	236.4
5	136.1	156.9	268.8	203.3	136.1	134.8	0.0	80.4	231.8	232.7
6	136.6	160.7	266.3	198.7	136.6	136.2	0.0	85.3	228.6	229.9
7	135.8	157.1	262.1	189.5	135.8	130.1	0.0	88.1	224.2	226.0
8	136.0	156.9	259.4	183.1	136.0	127.4	0.0	91.7	220.9	223.2
9	134.7	167.8	240.2	175.1	134.7	137.6	0.0	96.0	198.9	204.4
10	130.2	190.5	211.7	163.9	130.2	151.3	0.0	115.8	166.9	178.8
11	128.2	193.4	204.1	160.6	128.2	151.7	0.0	119.9	158.8	172.8

RP	ABS MACH NO		REL MACH NO		MERID MACH NO		MERID PEAK SS	
	IN	OUT	IN	OUT	IN	OUT	VEL R	MACH NO
1	0.381	0.452	0.948	0.726	0.381	0.395	1.067	1.258
2	0.390	0.453	0.932	0.720	0.390	0.400	1.055	1.245
3	0.403	0.451	0.867	0.661	0.403	0.397	1.011	1.242
4	0.408	0.453	0.814	0.603	0.408	0.391	0.985	1.226
5	0.407	0.457	0.803	0.592	0.407	0.392	0.990	1.220
6	0.408	0.467	0.795	0.577	0.408	0.396	0.998	1.216
7	0.406	0.456	0.783	0.550	0.406	0.378	0.958	1.209
8	0.406	0.455	0.775	0.531	0.406	0.369	0.937	1.206
9	0.402	0.489	0.717	0.510	0.402	0.401	1.021	1.191
10	0.389	0.558	0.632	0.480	0.389	0.443	1.162	1.161
11	0.382	0.566	0.609	0.470	0.382	0.444	1.183	1.149

RP	PERCENT SPAN		INCIDENCE		DEV	D-FACT	EFF	LOSS COEFF		LOSS PARAM	
	SPAN	MEAN	SS	TOT				PROF	TOT	PROF	
1	5.00	4.8	2.0	1.4	0.300	0.815	0.099	0.096	0.020	0.020	
2	10.00	5.0	2.0	1.2	0.291	0.855	0.075	0.074	0.015	0.015	
3	30.00	6.8	2.7	1.3	0.300	0.910	0.048	0.047	0.010	0.009	
4	45.00	7.9	2.9	2.1	0.329	0.878	0.071	0.071	0.014	0.014	
5	47.50	8.0	2.9	1.9	0.335	0.874	0.076	0.076	0.015	0.015	
6	50.00	8.2	2.9	1.1	0.350	0.865	0.086	0.086	0.018	0.018	
7	52.50	8.4	3.0	2.1	0.377	0.805	0.128	0.128	0.026	0.026	
8	55.00	8.5	3.0	2.4	0.398	0.775	0.153	0.153	0.031	0.031	
9	70.00	9.3	3.1	1.9	0.377	0.858	0.108	0.108	0.022	0.022	
10	90.00	10.1	3.0	0.2	0.351	0.930	0.071	0.071	0.015	0.015	
11	95.00	10.4	3.1	2.3	0.342	0.932	0.074	0.074	0.015	0.015	

TABLE VII. - Continued. - BLADE-ELEMENT DATA AT BLADE

EDGES FOR ROTOR 17

(q) 70 Percent of design speed; reading number 1175

RP	RADII		ABS BETAM		REL BETAM		TOTAL TEMP		TOTAL PRESS	
	IN	OUT	IN	OUT	IN	OUT	IN	RATIO	IN	RATIO
1	24.615	24.252	0.0	39.4	69.6	58.0	288.4	1.097	10.10	1.273
2	24.044	23.716	0.0	38.1	68.5	56.8	288.3	1.090	10.13	1.269
3	21.720	21.580	0.0	39.4	66.0	54.4	288.2	1.082	10.13	1.248
4	19.934	19.975	0.0	41.3	64.0	49.3	288.1	1.082	10.14	1.249
5	19.632	19.708	0.0	41.8	63.7	48.5	287.9	1.082	10.14	1.248
6	19.329	19.441	0.0	43.7	63.4	47.9	288.0	1.082	10.14	1.243
7	19.025	19.174	0.0	45.5	63.0	48.1	288.1	1.083	10.14	1.234
8	18.720	18.908	0.0	47.4	62.7	47.4	288.0	1.083	10.14	1.231
9	16.838	17.302	0.0	44.1	60.2	37.7	288.0	1.080	10.14	1.248
10	14.158	15.166	0.0	41.6	56.1	23.1	288.0	1.077	10.13	1.278
11	13.447	14.630	0.0	42.4	55.1	20.1	288.0	1.076	10.13	1.270

RP	ABS VEL		REL VEL		MERID VEL		TANG VEL		WHEEL SPEED	
	IN	OUT	IN	OUT	IN	OUT	IN	OUT	IN	OUT
1	107.9	153.0	310.2	223.3	107.9	118.2	0.0	97.1	290.9	286.6
2	111.5	153.8	304.7	221.0	111.5	121.1	0.0	94.9	283.6	279.8
3	114.0	148.6	280.4	197.2	114.0	114.9	0.0	94.2	256.2	254.5
4	114.9	154.1	262.3	177.7	114.9	115.8	0.0	101.6	235.9	236.3
5	114.6	154.5	258.8	173.6	114.6	115.1	0.0	103.0	232.1	233.0
6	114.5	153.9	255.4	166.1	114.5	111.3	0.0	106.3	228.3	229.6
7	114.2	151.3	251.9	158.8	114.2	106.0	0.0	108.0	224.5	226.3
8	114.4	151.9	249.1	151.8	114.4	102.8	0.0	111.8	221.3	223.5
9	114.2	163.6	229.6	148.5	114.2	117.5	0.0	113.9	199.2	204.7
10	112.4	182.3	201.6	148.2	112.4	136.3	0.0	121.1	167.4	179.3
11	111.1	183.2	194.0	144.0	111.1	135.2	0.0	123.6	159.1	173.1

RP	ABS MACH NO		REL MACH NO		MERID MACH NO		MERID PEAK SS	
	IN	OUT	IN	OUT	IN	OUT	VEL R	MACH NO
1	0.320	0.437	0.921	0.638	0.320	0.358	1.095	1.331
2	0.331	0.441	0.905	0.634	0.331	0.347	1.086	1.314
3	0.339	0.428	0.833	0.567	0.339	0.331	1.008	1.301
4	0.342	0.444	0.780	0.512	0.342	0.334	1.008	1.282
5	0.341	0.445	0.770	0.500	0.341	0.332	1.005	1.277
6	0.341	0.443	0.759	0.478	0.341	0.321	0.972	1.270
7	0.339	0.435	0.749	0.457	0.339	0.305	0.928	1.264
8	0.340	0.437	0.741	0.437	0.340	0.296	0.899	1.259
9	0.339	0.473	0.683	0.429	0.339	0.340	1.029	1.234
10	0.334	0.531	0.599	0.432	0.334	0.397	1.213	1.188
11	0.330	0.534	0.577	0.420	0.330	0.394	1.217	1.171

RP	PERCENT SPAN		INCIDENCE MEAN		DEV	D-FACT	EFF	LOSS COEFF		LOSS PARAM	
	SPAN	MEAN	SS	TOT				PROF	TOT	PROF	
1	5.00	8.2	5.4	2.4	0.397	0.734	0.187	0.182	0.037	0.036	
2	10.00	8.4	5.3	1.8	0.389	0.782	0.148	0.145	0.030	0.029	
3	30.00	10.6	6.4	2.5	0.409	0.800	0.141	0.140	0.028	0.027	
4	45.00	11.9	7.0	1.9	0.443	0.801	0.157	0.157	0.032	0.032	
5	47.50	12.2	7.1	1.9	0.451	0.797	0.163	0.163	0.033	0.033	
6	50.00	12.4	7.1	2.3	0.475	0.778	0.183	0.183	0.037	0.037	
7	52.50	12.6	7.2	3.5	0.497	0.748	0.213	0.213	0.042	0.042	
8	55.00	12.8	7.3	3.8	0.522	0.736	0.228	0.228	0.045	0.045	
9	70.00	13.6	7.4	1.4	0.485	0.817	0.176	0.176	0.037	0.037	
10	90.00	14.2	7.0	0.7	0.402	0.949	0.061	0.061	0.012	0.012	
11	95.00	14.4	7.1	3.2	0.398	0.933	0.084	0.084	0.017	0.017	

TABLE VII. - Continued. - BLADE-ELEMENT DATA AT BLADE

EDGES FOR ROTOR 17

(r) 70 Percent of design speed; reading number 1176

RP	RADII		ABS BETAM		REL BETAM		TOTAL TEMP		TOTAL PRESS	
	IN	OUT	IN	OUT	IN	OUT	IN	RATIO	IN	RATIO
1	24.615	24.252	0.0	59.9	72.7	61.5	288.6	1.132	10.11	1.297
2	24.044	23.716	0.0	52.5	71.7	59.1	288.4	1.120	10.13	1.283
3	21.720	21.580	0.0	45.2	69.2	55.0	288.1	1.093	10.13	1.262
4	19.934	19.975	0.0	46.8	67.1	49.6	288.0	1.090	10.13	1.263
5	19.632	19.708	0.0	47.4	66.7	48.7	287.9	1.090	10.14	1.262
6	19.329	19.441	0.0	49.1	66.4	48.6	288.0	1.090	10.14	1.256
7	19.025	19.174	0.0	51.6	66.0	49.2	288.0	1.090	10.13	1.247
8	18.720	18.908	-0.0	53.5	65.6	48.7	288.3	1.090	10.14	1.241
9	16.838	17.302	0.0	49.2	63.1	37.7	288.0	1.086	10.14	1.254
10	14.158	15.166	0.0	43.2	58.9	23.8	288.0	1.077	10.14	1.280
11	13.447	14.630	0.0	43.8	57.9	20.7	287.9	1.076	10.13	1.272

RP	ABS VEL		REL VEL		MERID VEL		TANG VEL		WHEEL SPEED	
	IN	OUT	IN	OUT	IN	OUT	IN	OUT	IN	OUT
1	90.7	160.4	305.1	168.6	90.7	80.4	0.0	138.8	291.3	287.0
2	94.1	154.8	299.3	183.5	94.1	94.2	0.0	122.8	284.2	280.3
3	97.5	148.2	274.0	182.3	97.5	104.5	0.0	105.1	256.1	254.5
4	99.2	153.4	254.8	162.1	99.2	105.1	0.0	111.8	234.8	235.2
5	99.3	154.1	251.5	157.8	99.3	104.2	0.0	113.5	231.1	232.0
6	99.4	152.8	248.4	151.3	99.4	100.0	0.0	115.5	227.7	229.0
7	99.7	150.4	245.4	142.9	99.7	93.4	0.0	117.9	224.3	226.0
8	99.7	150.0	241.6	135.3	99.7	89.2	-0.0	120.6	220.1	222.3
9	100.3	161.2	222.0	133.1	100.3	105.3	0.0	122.0	198.0	203.5
10	100.2	176.9	193.9	141.0	100.2	129.0	0.0	121.0	166.1	177.9
11	99.0	177.9	186.1	137.3	99.0	128.5	0.0	123.1	157.7	171.5

RP	ABS MACH NO		REL MACH NO		MERID MACH NO		MERID PEAK SS	
	IN	OUT	IN	OUT	IN	OUT	VEL R	MACH NO
1	0.268	0.452	0.902	0.475	0.268	0.226	0.886	1.400
2	0.279	0.438	0.886	0.519	0.279	0.266	1.001	1.381
3	0.289	0.424	0.812	0.522	0.289	0.299	1.072	1.354
4	0.294	0.440	0.756	0.465	0.294	0.302	1.060	1.321
5	0.295	0.442	0.746	0.453	0.295	0.299	1.050	1.314
6	0.295	0.438	0.737	0.434	0.295	0.287	1.006	1.309
7	0.296	0.431	0.728	0.410	0.296	0.268	0.937	1.302
8	0.296	0.430	0.716	0.388	0.296	0.256	0.895	1.291
9	0.297	0.464	0.658	0.383	0.297	0.303	1.050	1.258
10	0.297	0.514	0.575	0.410	0.297	0.375	1.288	1.198
11	0.293	0.518	0.552	0.400	0.293	0.374	1.298	1.178

RP	PERCENT SPAN		INCIDENCE MEAN		DEV	D-FACT	EFF	LOSS COEFF		LOSS PARAM	
	SPAN	MEAN	SS	TOT				PROF	TOT	PROF	
1	5.00	11.3	8.5	5.9	0.618	0.587	0.381	0.372	0.068	0.067	
2	10.00	11.5	8.5	4.1	0.537	0.615	0.339	0.333	0.064	0.063	
3	30.00	13.7	9.6	3.2	0.463	0.742	0.210	0.209	0.040	0.040	
4	45.00	15.0	10.1	2.2	0.499	0.764	0.212	0.212	0.042	0.042	
5	47.50	15.2	10.1	2.1	0.510	0.763	0.217	0.217	0.044	0.044	
6	50.00	15.4	10.2	3.0	0.531	0.747	0.236	0.236	0.047	0.047	
7	52.50	15.6	10.2	4.6	0.560	0.725	0.261	0.261	0.050	0.050	
8	55.00	15.7	10.2	5.2	0.586	0.707	0.286	0.286	0.055	0.055	
9	70.00	16.6	10.3	1.4	0.547	0.781	0.237	0.237	0.049	0.049	
10	90.00	16.9	9.8	1.4	0.416	0.946	0.069	0.069	0.014	0.014	
11	95.00	17.2	9.9	3.8	0.407	0.938	0.083	0.083	0.016	0.016	

TABLE VII. - Continued. - BLADE-ELEMENT DATA AT BLADE

EDGES FOR ROTOR 17

(s) 60 Percent of design speed; reading number 1177

RP	RADII		ABS. BETAM		REL BETAM		TOTAL TEMP		TOTAL PRESS	
	IN	OUT	IN	OUT	IN	OUT	IN	RATIO	IN	RATIO
1	24.615	24.252	0.0	61.1	73.3	61.7	288.4	1.097	10.11	1.216
2	24.044	23.716	0.0	53.4	72.1	59.4	288.3	1.087	10.13	1.204
3	21.720	21.580	0.0	44.4	69.5	54.6	288.1	1.067	10.13	1.189
4	19.934	19.975	0.0	46.1	67.6	49.5	288.1	1.066	10.13	1.189
5	19.632	19.708	0.0	46.7	67.2	48.5	288.1	1.065	10.14	1.189
6	19.329	19.441	0.0	48.4	66.8	48.4	288.1	1.065	10.14	1.184
7	19.025	19.174	0.0	50.7	66.6	48.9	288.1	1.065	10.14	1.179
8	18.720	18.908	-0.0	52.9	66.2	48.8	288.1	1.065	10.13	1.175
9	16.858	17.302	0.0	49.4	63.7	38.3	288.1	1.064	10.14	1.182
10	14.158	15.166	0.0	43.0	59.5	23.6	288.0	1.057	10.13	1.202
11	13.447	14.630	0.0	43.7	58.7	20.7	288.0	1.056	10.13	1.197

RP	ABS VEL		REL VEL		MERID VEL		TANG VEL		WHEEL SPEED	
	IN	OUT	IN	OUT	IN	OUT	IN	OUT	IN	OUT
1	74.5	137.6	258.7	140.5	74.5	66.6	0.0	120.4	247.7	244.1
2	78.1	132.0	254.4	154.4	78.1	78.6	0.0	106.0	242.2	238.9
3	81.4	127.1	233.0	156.8	81.4	90.7	0.0	89.0	218.3	216.9
4	82.7	131.2	217.1	140.2	82.7	91.0	0.0	94.5	200.7	201.1
5	82.9	131.8	214.0	136.3	82.9	90.3	0.0	96.0	197.3	198.0
6	83.1	130.4	211.0	130.4	83.1	86.5	0.0	97.5	194.0	195.1
7	83.1	128.9	208.9	124.0	83.1	81.6	0.0	99.8	191.7	193.2
8	83.2	128.2	206.2	117.4	83.2	77.3	-0.0	102.2	188.6	190.5
9	84.0	137.0	189.3	113.5	84.0	89.1	0.0	104.1	169.7	174.4
10	83.7	151.6	164.6	120.9	83.7	110.8	0.0	103.4	141.8	151.9
11	82.4	152.9	158.6	118.3	82.4	110.6	0.0	105.5	135.5	147.4

RP	ABS MACH NO		REL MACH NO		MERID MACH NO		MERID PEAK SS	
	IN	OUT	IN	OUT	IN	OUT	VEL R	MACH NO
1	0.220	0.392	0.764	0.400	0.220	0.190	0.894	1.199
2	0.231	0.377	0.752	0.441	0.231	0.225	1.006	1.183
3	0.241	0.366	0.689	0.452	0.241	0.262	1.114	1.157
4	0.244	0.379	0.642	0.405	0.244	0.263	1.101	1.134
5	0.245	0.381	0.633	0.394	0.245	0.261	1.090	1.125
6	0.246	0.376	0.624	0.377	0.246	0.250	1.041	1.117
7	0.246	0.372	0.618	0.358	0.246	0.236	0.982	1.117
8	0.246	0.370	0.610	0.339	0.246	0.223	0.929	1.111
9	0.248	0.396	0.560	0.328	0.248	0.258	1.060	1.080
10	0.247	0.442	0.487	0.352	0.247	0.323	1.324	1.025
11	0.244	0.446	0.469	0.345	0.244	0.323	1.343	1.015

RP	PERCENT SPAN		INCIDENCE		DEV	D-FACT	EFF	LOSS COEFF		LOSS PARAM	
	MEAN	SS	MEAN	SS				TOT	PROF	TOT	PROF
1	5.00	11.8	9.0	6.1	0.631	0.592	0.373	0.373	0.067	0.067	
2	10.00	12.0	8.9	4.4	0.546	0.623	0.324	0.324	0.061	0.061	
3	30.00	14.1	10.0	2.8	0.455	0.761	0.189	0.189	0.037	0.037	
4	45.00	15.5	10.6	2.1	0.489	0.774	0.198	0.198	0.040	0.040	
5	47.50	15.7	10.6	2.0	0.500	0.774	0.202	0.202	0.041	0.041	
6	50.00	15.8	10.6	2.9	0.521	0.759	0.220	0.220	0.044	0.044	
7	52.50	16.1	10.8	4.3	0.548	0.739	0.242	0.242	0.047	0.047	
8	55.00	16.3	10.8	5.3	0.576	0.723	0.263	0.263	0.050	0.050	
9	70.00	17.1	10.8	1.9	0.547	0.771	0.248	0.248	0.051	0.051	
10	90.00	17.5	10.4	1.2	0.410	0.950	0.063	0.063	0.013	0.013	
11	95.00	18.0	10.7	3.8	0.400	0.936	0.087	0.087	0.017	0.017	

TABLE VII. - Concluded. - BLADE-ELEMENT DATA AT BLADE

EDGES FOR ROTOR 17

(t) 50 Percent of design speed; reading number 1178

RP	RADII		ABS BETAM		REL BETAM		TOTAL TEMP		TOTAL PRESS	
	IN	OUT	IN	OUT	IN	OUT	IN	RATIO	IN	RATIO
1	24.615	24.252	0.0	59.8	73.6	61.3	288.5	1.068	10.11	1.150
2	24.044	23.716	0.0	52.4	72.5	59.1	288.3	1.061	10.13	1.142
3	21.720	21.580	0.0	44.6	69.9	54.7	288.2	1.047	10.13	1.132
4	19.934	19.975	0.0	46.1	67.9	49.3	288.1	1.046	10.13	1.133
5	19.632	19.708	0.0	46.8	67.6	48.7	288.1	1.046	10.13	1.132
6	19.329	19.441	0.0	48.8	67.3	48.5	288.0	1.046	10.13	1.129
7	19.025	19.174	0.0	51.3	66.9	49.0	288.1	1.046	10.13	1.125
8	18.720	18.908	0.0	53.2	66.6	48.6	288.0	1.046	10.13	1.123
9	16.838	17.302	0.0	49.2	64.1	37.5	288.0	1.045	10.13	1.128
10	14.158	15.166	0.0	43.1	59.9	24.0	288.0	1.040	10.13	1.140
11	13.447	14.630	0.0	43.9	59.0	20.9	288.0	1.040	10.13	1.136

RP	ABS VEL		REL VEL		MERID VEL		TANG VEL		WHEEL SPEED	
	IN	OUT	IN	OUT	IN	OUT	IN	OUT	IN	OUT
1	60.9	114.8	216.3	120.1	60.9	57.7	0.0	99.2	207.5	204.5
2	64.0	110.6	213.0	131.4	64.0	67.4	0.0	87.7	203.2	200.4
3	67.0	106.8	195.4	131.7	67.0	76.1	0.0	74.9	183.6	182.4
4	68.3	110.7	181.8	117.6	68.3	76.7	0.0	79.7	168.5	168.8
5	68.3	110.5	179.4	114.6	68.3	75.7	0.0	80.5	165.9	166.6
6	68.5	109.8	177.1	109.1	68.5	72.4	0.0	82.6	163.4	164.3
7	68.6	108.0	174.7	102.8	68.6	67.5	0.0	84.3	160.6	161.9
8	68.5	107.9	172.2	97.6	68.5	64.6	0.0	86.4	158.0	159.6
9	69.0	115.9	157.9	95.4	69.0	75.7	0.0	87.8	142.0	145.9
10	69.3	126.9	138.1	101.5	69.3	92.7	0.0	86.7	119.5	128.0
11	68.2	127.7	132.6	98.5	68.2	92.0	0.0	88.6	113.7	123.7

RP	ABS MACH NO		REL MACH NO		MERID MACH NO		MERID PEAK SS	
	IN	OUT	IN	OUT	IN	OUT	VEL R	MACH NO
1	0.179	0.330	0.637	0.345	0.179	0.166	0.948	1.009
2	0.189	0.319	0.628	0.378	0.189	0.194	1.054	0.997
3	0.198	0.310	0.576	0.382	0.198	0.221	1.135	0.977
4	0.201	0.321	0.536	0.341	0.201	0.223	1.124	0.953
5	0.202	0.321	0.530	0.333	0.202	0.220	1.108	0.949
6	0.202	0.319	0.523	0.317	0.202	0.210	1.057	0.944
7	0.203	0.313	0.515	0.298	0.203	0.196	0.984	0.937
8	0.202	0.313	0.508	0.283	0.202	0.187	0.943	0.933
9	0.204	0.337	0.466	0.278	0.204	0.220	1.096	0.906
10	0.205	0.371	0.408	0.297	0.205	0.271	1.338	0.865
11	0.201	0.373	0.391	0.288	0.201	0.269	1.348	0.852

RP	PERCENT		INCIDENCE		DEV	D-FACT	EFF	LOSS COEFF		LOSS PARAM	
	SPAN	MEAN	SS	SS				TOT	PROF	TOT	PROF
1	5.00	12.2	9.4	5.6	0.617	0.601	0.356	0.356	0.065	0.065	
2	10.00	12.4	9.3	4.1	0.534	0.631	0.310	0.310	0.059	0.059	
3	30.00	14.5	10.4	2.9	0.454	0.768	0.178	0.178	0.034	0.034	
4	45.00	15.9	10.9	1.8	0.489	0.789	0.181	0.181	0.036	0.036	
5	47.50	16.1	11.0	2.2	0.498	0.781	0.192	0.192	0.039	0.039	
6	50.00	16.3	11.0	2.9	0.524	0.766	0.210	0.210	0.042	0.042	
7	52.50	16.4	11.1	4.4	0.555	0.739	0.241	0.241	0.047	0.047	
8	55.00	16.7	11.2	5.0	0.580	0.728	0.257	0.257	0.049	0.049	
9	70.00	17.5	11.2	1.2	0.544	0.787	0.229	0.229	0.048	0.048	
10	90.00	17.9	10.8	1.7	0.409	0.952	0.061	0.061	0.012	0.012	
11	95.00	18.3	11.0	4.0	0.404	0.937	0.085	0.085	0.017	0.017	

TABLE VIII. - BLADE-ELEMENT DATA AT BLADE EDGES FOR STATOR 12

(a) 100 Percent of design speed; reading number 1143

RP	RADII		ABS. BETAM		REL BETAM		TOTAL TEMP		TOTAL PRESS	
	IN	OUT	IN	OUT	IN	OUT	IN	RATIO	IN	RATIO
1	23.904	23.884	25.2	0.6	25.2	0.6	333.3	0.997	14.55	0.934
2	23.437	23.426	24.1	-1.4	24.1	-1.4	331.1	0.997	14.62	0.967
3	21.542	21.603	24.1	-3.1	24.1	-3.1	325.4	0.998	14.46	0.960
4	20.096	20.234	27.6	-2.8	27.6	-2.8	328.1	0.990	14.50	0.941
5	19.855	20.005	28.4	-3.4	28.4	-3.4	327.2	0.992	14.20	0.951
6	19.614	19.779	29.0	-3.8	29.0	-3.8	325.1	0.997	13.69	0.980
7	19.373	19.550	29.8	-4.1	29.8	-4.1	323.9	1.000	13.32	1.006
8	19.131	19.324	30.7	-3.9	30.7	-3.9	324.8	1.000	13.45	0.999
9	17.676	17.973	28.7	-3.7	28.7	-3.7	325.3	0.998	14.53	0.958
10	15.735	16.215	30.2	-0.6	30.2	-0.6	327.4	1.000	15.45	0.920
11	15.253	15.786	31.5	3.7	31.5	3.7	327.5	0.999	15.26	0.868

RP	ABS VEL		REL VEL		MERID VEL		TANG VEL		WHEEL SPEED	
	IN	OUT	IN	OUT	IN	OUT	IN	OUT	IN	OUT
1	259.7	242.4	259.7	242.4	235.0	242.4	110.6	2.7	0.	0.
2	262.1	254.6	262.1	254.6	239.2	254.5	107.1	-6.4	0.	0.
3	253.3	248.5	253.3	248.5	231.2	248.2	103.3	-13.3	0.	0.
4	260.4	247.5	260.4	247.5	230.8	247.2	120.5	-12.0	0.	0.
5	252.2	244.5	252.2	244.5	221.9	244.1	119.9	-14.3	0.	0.
6	235.7	243.1	235.7	243.1	206.1	242.6	114.4	-16.1	0.	0.
7	222.8	243.2	222.8	243.2	193.3	242.6	110.9	-17.2	0.	0.
8	228.1	245.8	228.1	245.8	196.2	245.2	116.4	-16.9	0.	0.
9	268.6	266.3	268.6	266.3	235.6	265.8	128.9	-17.2	0.	0.
10	307.1	314.1	307.1	314.1	265.3	314.1	154.6	-3.2	0.	0.
11	297.6	286.2	297.6	286.2	253.7	285.6	155.7	18.4	0.	0.

RP	ABS MACH NO		REL MACH NO		MERID MACH NO		MERID PEAK SS	
	IN	OUT	IN	OUT	IN	OUT	VEL R	MACH NO
1	0.748	0.695	0.748	0.695	0.677	0.695	1.032	0.748
2	0.759	0.736	0.759	0.736	0.692	0.736	1.064	0.759
3	0.737	0.723	0.737	0.723	0.673	0.722	1.073	0.737
4	0.757	0.719	0.757	0.719	0.671	0.719	1.071	0.782
5	0.732	0.710	0.732	0.710	0.644	0.709	1.100	0.786
6	0.682	0.707	0.682	0.707	0.596	0.705	1.177	0.748
7	0.643	0.707	0.643	0.707	0.557	0.705	1.255	0.725
8	0.658	0.714	0.658	0.714	0.566	0.713	1.250	0.761
9	0.788	0.781	0.788	0.781	0.691	0.779	1.128	0.788
10	0.915	0.940	0.915	0.940	0.790	0.939	1.184	0.915
11	0.882	0.844	0.882	0.844	0.752	0.842	1.126	0.882

RP	PERCENT		INCIDENCE		DEV	D-FACT	EFF	LOSS COEFF		LOSS PARAM	
	SPAN	MEAN	SS	TOT				PROF	TOT	PROF	
1	5.00	-2.5	-8.9	9.1	0.227	0.	0.214	0.214	0.083	0.083	
2	10.00	-3.0	-9.4	6.7	0.193	0.	0.104	0.104	0.039	0.039	
3	30.00	-3.1	-9.5	4.5	0.179	0.	0.130	0.130	0.045	0.045	
4	45.00	-0.5	-6.9	4.6	0.215	0.	0.186	0.186	0.061	0.061	
5	47.50	0.1	-6.3	4.0	0.201	0.	0.165	0.165	0.053	0.053	
6	50.00	0.5	-5.9	3.6	0.144	0.	0.073	0.073	0.023	0.023	
7	52.50	1.1	-5.3	3.3	0.088	0.	-0.023	-0.023	-0.007	-0.007	
8	55.00	1.7	-4.7	3.4	0.103	0.	0.003	0.003	0.001	0.001	
9	70.00	-1.8	-8.2	3.7	0.164	0.	0.125	0.125	0.036	0.036	
10	90.00	-3.3	-9.6	7.0	0.107	0.	0.192	0.192	0.049	0.049	
11	95.00	-3.1	-9.4	11.4	0.151	0.	0.332	0.332	0.082	0.082	

TABLE VIII. - Continued. BLADE-ELEMENT DATA AT BLADE

EDGES FOR STATOR 12

(b) 100 Percent of design speed; reading number 1144

RP	RADII		ABS BETAM		REL BETAM		TOTAL TEMP		TOTAL PRESS	
	IN	OUT	IN	OUT	IN	OUT	IN	RATIO	IN	RATIO
1	23.904	23.884	34.8	1.4	34.8	1.4	349.4	0.992	16.52	0.967
2	23.437	23.426	31.7	0.6	31.7	0.6	342.9	0.998	16.52	0.979
3	21.542	21.603	32.2	-2.4	32.2	-2.4	335.7	0.997	16.09	0.984
4	20.096	20.234	34.7	-1.6	34.7	-1.6	334.8	0.997	16.02	0.964
5	19.855	20.005	35.4	-2.1	35.4	-2.1	334.9	0.996	15.79	0.968
6	19.614	19.779	36.6	-2.6	36.6	-2.6	334.4	0.997	15.49	0.975
7	19.373	19.550	39.0	-2.7	39.0	-2.7	334.3	0.997	15.12	0.994
8	19.131	19.324	40.0	-3.1	40.0	-3.1	334.7	0.995	15.05	0.994
9	17.676	17.973	36.9	-3.0	36.9	-3.0	332.4	0.996	15.56	0.977
10	15.735	16.215	36.4	-2.7	36.4	-2.7	331.0	0.999	15.95	0.958
11	15.253	15.786	37.6	0.9	37.6	0.9	331.3	1.000	15.76	0.940

RP	ABS VEL		REL VEL		MERID VEL		TANG VEL		WHEEL SPEED	
	IN	OUT	IN	OUT	IN	OUT	IN	OUT	IN	OUT
1	258.4	205.9	258.4	205.9	212.2	205.8	147.4	5.1	0.	0.
2	257.1	209.6	257.1	209.6	218.7	209.6	135.3	2.3	0.	0.
3	243.2	199.8	243.2	199.8	205.9	199.6	129.5	-8.4	0.	0.
4	248.3	191.9	248.3	191.9	204.2	191.8	141.2	-5.3	0.	0.
5	243.5	187.7	243.5	187.7	198.6	187.6	140.9	-7.0	0.	0.
6	236.1	182.8	236.1	182.8	189.6	182.6	140.7	-8.4	0.	0.
7	225.8	180.6	225.8	180.6	175.6	180.4	142.0	-8.5	0.	0.
8	225.5	178.9	225.5	178.9	172.7	178.7	145.0	-9.7	0.	0.
9	249.0	191.2	249.0	191.2	199.2	191.0	149.4	-9.8	0.	0.
10	271.6	203.9	271.6	203.9	218.7	203.7	161.1	-9.7	0.	0.
11	270.1	191.7	270.1	191.7	213.8	191.7	165.0	3.0	0.	0.

RP	ABS MACH NO		REL MACH NO		MERID MACH NO		MERID PEAK SS	
	IN	OUT	IN	OUT	IN	OUT	VEL R	MACH NO
1	0.725	0.569	0.725	0.569	0.595	0.569	0.970	1.012
2	0.729	0.584	0.729	0.584	0.620	0.584	0.959	0.943
3	0.693	0.562	0.693	0.562	0.587	0.561	0.970	0.894
4	0.710	0.539	0.710	0.539	0.584	0.539	0.939	0.953
5	0.695	0.527	0.695	0.527	0.567	0.526	0.945	0.946
6	0.673	0.512	0.673	0.512	0.540	0.512	0.963	0.938
7	0.641	0.506	0.641	0.506	0.498	0.506	1.027	0.942
8	0.639	0.501	0.639	0.501	0.490	0.501	1.035	0.958
9	0.715	0.539	0.715	0.539	0.572	0.539	0.959	0.958
10	0.790	0.576	0.790	0.578	0.636	0.577	0.932	0.966
11	0.784	0.540	0.784	0.540	0.621	0.540	0.896	0.969

RP	PERCENT SPAN		INCIDENCE		DEV	D-FACT	EFF	LOSS COEFF		LOSS PARAM	
	SPAN	MEAN	MEAN	SS				TOT	PROF	TOT	PROF
1	5.00	7.1	0.7		9.9	0.416	0.	0.112	0.112	0.043	0.043
2	10.00	4.6	-1.8		8.7	0.380	0.	0.071	0.071	0.027	0.027
3	30.00	5.0	-1.4		5.1	0.376	0.	0.057	0.057	0.020	0.020
4	45.00	6.5	0.1		5.8	0.419	0.	0.127	0.127	0.041	0.041
5	47.50	7.1	0.6		5.2	0.424	0.	0.117	0.117	0.038	0.038
6	50.00	8.1	1.6		4.7	0.426	0.	0.094	0.094	0.030	0.030
7	52.50	10.2	3.8		4.7	0.409	0.	0.024	0.024	0.008	0.008
8	55.00	11.0	4.6		4.3	0.418	0.	0.025	0.025	0.008	0.008
9	70.00	6.4	-0.0		4.4	0.414	0.	0.078	0.078	0.022	0.022
10	90.00	2.9	-3.4		4.9	0.408	0.	0.125	0.125	0.032	0.032
11	95.00	3.1	-3.2		8.6	0.437	0.	0.181	0.181	0.045	0.045

TABLE VIII. - Continued. BLADE-ELEMENT DATA AT BLADE

EDGES FOR STATOR 12

(c) 100 Percent of design speed; reading number 1145

RP	RADII		ABS BETAM		REL BETAM		TOTAL TEMP		TOTAL PRESS	
	IN	OUT	IN	OUT	IN	OUT	IN	RATIO	IN	RATIO
1	23.904	23.884	38.0	1.7	38.0	1.7	354.5	0.998	17.34	0.961
2	23.437	23.426	36.4	1.6	36.4	1.6	349.0	1.000	17.20	0.980
3	21.542	21.603	36.3	-1.0	36.3	-1.0	340.2	0.998	16.60	0.980
4	20.096	20.234	38.1	-0.9	38.1	-0.9	337.8	0.999	16.30	0.959
5	19.855	20.005	39.2	-1.0	39.2	-1.0	337.3	0.999	16.17	0.960
6	19.614	19.779	40.2	-1.3	40.2	-1.3	337.7	0.997	16.04	0.963
7	19.373	19.550	42.5	-1.3	42.5	-1.3	338.9	0.995	15.80	0.973
8	19.131	19.324	44.5	-1.2	44.5	-1.2	338.6	0.996	15.65	0.981
9	17.676	17.973	41.0	-0.6	41.0	-0.6	335.5	0.997	15.96	0.967
10	15.735	16.215	39.6	-1.6	39.6	-1.6	332.8	0.999	16.09	0.961
11	15.253	15.786	40.5	2.3	40.5	2.3	332.8	1.001	16.10	0.930

RP	ABS VEL		REL VEL		MERID VEL		TANG VEL		WHEEL SPEED	
	IN	OUT	IN	OUT	IN	OUT	IN	OUT	IN	OUT
1	259.9	203.0	259.9	203.0	204.9	202.9	159.9	5.9	0.	0.
2	256.3	207.4	256.3	207.4	206.3	207.4	152.0	5.7	0.	0.
3	239.4	190.2	239.4	190.2	192.9	190.2	141.7	-3.3	0.	0.
4	238.9	173.8	238.9	173.8	188.1	173.8	147.3	-2.7	0.	0.
5	236.2	171.3	236.2	171.3	183.1	171.3	149.3	-3.1	0.	0.
6	233.8	169.4	233.8	169.4	178.5	169.4	150.9	-3.8	0.	0.
7	228.9	167.2	228.9	167.2	168.8	167.2	154.6	-3.8	0.	0.
8	225.9	167.1	225.9	167.1	161.2	167.1	158.4	-3.4	0.	0.
9	244.4	173.9	244.4	173.9	184.3	173.9	160.5	-1.7	0.	0.
10	260.4	184.6	260.4	184.6	200.7	184.5	165.8	-5.2	0.	0.
11	264.2	169.4	264.2	169.4	200.9	169.3	171.6	6.7	0.	0.

RP	ABS MACH NO		REL MACH NO		MERID MACH NO		MERID PEAK SS	
	IN	OUT	IN	OUT	IN	OUT	VEL R	MACH NO
1	0.724	0.555	0.724	0.555	0.571	0.554	0.990	1.090
2	0.719	0.572	0.719	0.572	0.579	0.572	1.005	1.048
3	0.676	0.529	0.676	0.529	0.545	0.529	0.986	0.970
4	0.677	0.483	0.677	0.483	0.533	0.483	0.924	0.989
5	0.670	0.476	0.670	0.476	0.519	0.476	0.936	0.999
6	0.662	0.471	0.662	0.471	0.505	0.471	0.949	1.006
7	0.646	0.464	0.646	0.464	0.476	0.464	0.990	1.026
8	0.637	0.464	0.637	0.464	0.454	0.463	1.037	1.051
9	0.697	0.485	0.697	0.485	0.526	0.485	0.943	1.035
10	0.751	0.518	0.751	0.518	0.579	0.518	0.919	1.007
11	0.764	0.473	0.764	0.473	0.581	0.473	0.842	1.024

RP	PERCENT		INCIDENCE		DEV	D-FACT	EFF	LOSS COEFF		LOSS PARAM	
	SPAN	MEAN	MEAN	SS				TOT	PROF	TOT	PROF
1	5.00	10.3	10.3	3.8	10.2	0.448	0.	0.131	0.131	0.051	0.051
2	10.00	9.3	9.3	2.8	9.7	0.407	0.	0.068	0.068	0.026	0.026
3	30.00	9.1	9.1	2.7	6.5	0.416	0.	0.075	0.075	0.026	0.026
4	45.00	9.9	9.9	3.5	6.5	0.476	0.	0.156	0.156	0.051	0.051
5	47.50	10.9	10.9	4.5	6.3	0.481	0.	0.153	0.153	0.049	0.049
6	50.00	11.7	11.7	5.3	6.1	0.485	0.	0.144	0.144	0.046	0.046
7	52.50	13.7	13.7	7.3	6.1	0.486	0.	0.109	0.109	0.034	0.034
8	55.00	15.5	15.5	9.1	6.2	0.481	0.	0.080	0.080	0.025	0.025
9	70.00	10.6	10.6	4.2	6.8	0.477	0.	0.119	0.119	0.034	0.034
10	90.00	6.1	6.1	-0.2	6.0	0.457	0.	0.126	0.126	0.032	0.032
11	95.00	5.9	5.9	-0.4	9.9	0.511	0.	0.219	0.219	0.054	0.054

TABLE VIII. - Continued. BLADE-ELEMENT DATA AT BLADE

EDGES FOR STATOR 12

(d) 100 Percent of design speed; reading number 1146

RP	RADII		ABS BETAM		REL BETAM		TOTAL TEMP		TOTAL PRESS	
	IN	OUT	IN	OUT	IN	OUT	IN	RATIO	IN	RATIO
1	23.904	23.884	40.6	3.4	40.6	3.4	356.7	1.003	17.54	0.954
2	23.437	23.426	39.3	2.9	39.3	2.9	352.0	1.001	17.44	0.968
3	21.542	21.603	38.6	0.6	38.6	0.6	342.1	0.999	16.70	0.969
4	20.096	20.234	41.9	-0.4	41.9	-0.4	340.4	0.996	16.26	0.958
5	19.855	20.005	43.2	-0.4	43.2	-0.4	340.5	0.997	16.17	0.961
6	19.614	19.779	44.9	-0.6	44.9	-0.6	340.6	0.994	16.05	0.963
7	19.373	19.550	46.9	-0.7	46.9	-0.7	341.0	0.995	15.83	0.975
8	19.131	19.324	48.8	-0.5	48.8	-0.5	341.8	0.993	15.76	0.976
9	17.676	17.973	44.0	0.1	44.0	0.1	337.1	0.997	15.86	0.967
10	15.735	16.215	40.8	0.2	40.8	0.2	334.2	0.999	16.37	0.944
11	15.253	15.786	40.8	3.7	40.8	3.7	333.4	1.000	16.25	0.922

RP	ABS VEL		REL VEL		MERID VEL		TANG VEL		WHEEL SPEED	
	IN	OUT	IN	OUT	IN	OUT	IN	OUT	IN	OUT
1	260.2	202.2	260.2	202.2	197.4	201.8	169.5	11.9	0.	0.
2	257.5	205.2	257.5	205.2	199.4	205.0	163.0	10.4	0.	0.
3	237.6	183.3	237.6	183.3	185.8	183.3	148.1	1.9	0.	0.
4	232.5	166.2	232.5	166.2	173.1	166.2	155.3	-1.0	0.	0.
5	230.4	164.4	230.4	164.4	168.1	164.4	157.6	-1.1	0.	0.
6	228.6	161.8	228.6	161.8	161.9	161.8	161.4	-1.7	0.	0.
7	224.7	161.0	224.7	161.0	153.7	161.0	163.9	-1.8	0.	0.
8	224.1	160.5	224.1	160.5	147.6	160.5	168.6	-1.5	0.	0.
9	237.3	162.5	237.3	162.5	170.5	162.5	164.9	0.1	0.	0.
10	262.3	175.4	262.3	175.4	198.6	175.4	171.4	0.7	0.	0.
11	264.7	160.3	264.7	160.3	200.5	159.9	172.8	10.4	0.	0.

RP	ABS MACH NO		REL MACH NO		MERID MACH NO		MERID PEAK SS	
	IN	OUT	IN	OUT	IN	OUT	VEL R	MACH NO
1	0.722	0.549	0.722	0.549	0.548	0.548	1.022	1.153
2	0.719	0.562	0.719	0.562	0.557	0.562	1.028	1.119
3	0.669	0.507	0.669	0.507	0.523	0.507	0.986	1.011
4	0.655	0.460	0.655	0.460	0.488	0.460	0.960	1.042
5	0.648	0.454	0.648	0.454	0.473	0.454	0.978	1.055
6	0.643	0.447	0.643	0.447	0.455	0.447	0.999	1.079
7	0.631	0.445	0.631	0.445	0.431	0.445	1.048	1.096
8	0.628	0.443	0.628	0.443	0.414	0.443	1.087	1.129
9	0.673	0.451	0.673	0.451	0.484	0.451	0.953	1.068
10	0.756	0.490	0.756	0.490	0.572	0.490	0.884	1.046
11	0.764	0.446	0.764	0.446	0.579	0.446	0.798	1.032

RP	PERCENT	INCIDENCE		DEV	D-FACT	EFF	LOSS COEFF		LOSS PARAM	
	SPAN	MEAN	SS				TOT	PROF	TOT	PROF
1	5.00	12.9	6.5	11.9	0.457	0.	0.156	0.156	0.060	0.060
2	10.00	12.1	5.7	11.0	0.427	0.	0.109	0.109	0.041	0.041
3	30.00	11.4	5.0	8.1	0.443	0.	0.120	0.120	0.042	0.042
4	45.00	13.8	7.4	7.0	0.503	0.	0.167	0.167	0.054	0.054
5	47.50	14.9	8.4	7.0	0.507	0.	0.158	0.158	0.051	0.051
6	50.00	16.4	10.0	6.8	0.518	0.	0.152	0.152	0.048	0.048
7	52.50	18.1	11.7	6.7	0.514	0.	0.108	0.108	0.034	0.034
8	55.00	19.8	13.4	6.8	0.518	0.	0.101	0.101	0.031	0.031
9	70.00	13.6	7.2	7.4	0.513	0.	0.124	0.124	0.036	0.036
10	90.00	7.3	1.0	7.8	0.495	0.	0.177	0.177	0.045	0.045
11	95.00	6.2	-0.1	11.4	0.544	0.	0.243	0.243	0.060	0.060

TABLE VIII. - Continued. BLADE-ELEMENT DATA AT BLADE

EDGES FOR STATOR 12

(e) 100 Percent of design speed; reading number 1147

RP	RADII		ABS BETAM		REL BETAM		TOTAL TEMP		TOTAL PRESS	
	IN	OUT	IN	OUT	IN	OUT	IN	RATIO	IN	RATIO
1	23.904	23.884	43.5	4.6	43.5	4.6	361.8	0.993	17.46	0.941
2	23.437	23.426	41.3	4.7	41.3	4.7	356.0	0.997	17.45	0.952
3	21.542	21.603	41.1	1.1	41.1	1.1	343.7	1.001	16.45	0.967
4	20.096	20.234	45.5	-0.5	45.5	-0.5	343.1	0.995	16.10	0.956
5	19.855	20.005	46.9	-0.9	46.9	-0.9	342.9	0.995	16.00	0.959
6	19.614	19.779	48.8	-1.1	48.8	-1.1	342.3	0.994	15.84	0.964
7	19.373	19.550	50.6	-1.4	50.6	-1.4	342.6	0.994	15.70	0.972
8	19.131	19.324	52.3	-1.4	52.3	-1.4	342.4	0.995	15.60	0.976
9	17.676	17.973	45.8	-0.1	45.8	-0.1	337.7	0.998	15.73	0.972
10	15.735	16.215	40.2	0.9	40.2	0.9	333.6	1.000	16.43	0.935
11	15.253	15.786	40.6	4.6	40.6	4.6	332.8	1.002	16.24	0.921

RP	ABS VEL		REL VEL		MERID VEL		TANG VEL		WHEEL SPEED	
	IN	OUT	IN	OUT	IN	OUT	IN	OUT	IN	OUT
1	259.7	196.6	259.7	196.6	188.2	196.0	178.8	15.8	0.	0.
2	258.8	201.0	258.8	201.0	194.5	200.3	170.7	16.5	0.	0.
3	232.0	176.9	232.0	176.9	175.0	176.9	152.4	3.3	0.	0.
4	229.2	160.9	229.2	160.9	160.7	160.9	163.4	-1.5	0.	0.
5	227.1	159.1	227.1	159.1	155.2	159.1	165.8	-2.4	0.	0.
6	223.6	157.0	223.6	157.0	147.4	156.9	168.2	-3.1	0.	0.
7	221.1	156.5	221.1	156.5	140.5	156.5	170.8	-3.7	0.	0.
8	220.1	155.2	220.1	155.2	134.6	155.2	174.1	-3.8	0.	0.
9	233.6	161.1	233.6	161.1	162.7	161.1	167.6	-0.3	0.	0.
10	263.3	173.2	263.3	173.2	201.0	173.2	170.0	2.6	0.	0.
11	264.1	160.6	264.1	160.6	200.6	160.1	171.9	12.9	0.	0.

RP	ABS MACH NO		REL MACH NO		MERID MACH NO		MERID PEAK SS	
	IN	OUT	IN	OUT	IN	OUT	VEL R	MACH NO
1	0.715	0.532	0.715	0.532	0.518	0.530	1.041	1.211
2	0.719	0.548	0.719	0.548	0.540	0.546	1.030	1.167
3	0.650	0.487	0.650	0.487	0.490	0.487	1.011	1.038
4	0.642	0.443	0.642	0.443	0.450	0.443	1.002	1.100
5	0.636	0.438	0.636	0.438	0.435	0.438	1.025	1.116
6	0.626	0.432	0.626	0.432	0.413	0.432	1.065	1.134
7	0.618	0.431	0.618	0.431	0.393	0.431	1.114	1.154
8	0.615	0.427	0.615	0.427	0.377	0.427	1.152	1.181
9	0.661	0.446	0.661	0.446	0.461	0.446	0.990	1.089
10	0.759	0.484	0.759	0.484	0.580	0.484	0.861	1.036
11	0.763	0.447	0.763	0.447	0.580	0.446	0.798	1.026

RP	PERCENT SPAN	INCIDENCE		DEV	D-FACT	EFF	LOSS COEFF		LOSS PARAM	
		MEAN	SS				TOT	PROF	TOT	PROF
1	5.00	15.8	9.4	13.1	0.485	0.	0.203	0.203	0.078	0.078
2	10.00	14.1	7.7	12.8	0.449	0.	0.163	0.163	0.062	0.062
3	30.00	13.9	7.5	8.6	0.461	0.	0.135	0.135	0.047	0.047
4	45.00	17.4	11.0	6.8	0.531	0.	0.183	0.183	0.060	0.060
5	47.50	18.6	12.2	6.5	0.537	0.	0.173	0.173	0.056	0.056
6	50.00	20.2	13.8	6.2	0.541	0.	0.153	0.153	0.049	0.049
7	52.50	21.8	15.4	6.0	0.539	0.	0.124	0.124	0.039	0.039
8	55.00	23.3	16.9	6.0	0.544	0.	0.107	0.107	0.033	0.033
9	70.00	15.4	9.0	7.2	0.515	0.	0.108	0.108	0.031	0.031
10	90.00	6.7	0.4	8.4	0.502	0.	0.205	0.205	0.053	0.053
11	95.00	6.0	-0.3	12.3	0.539	0.	0.248	0.248	0.061	0.061

TABLE VIII. - Continued. BLADE-ELEMENT DATA AT BLADE

EDGES FOR STATOR 12

(f) 100 Percent of design speed; reading number 1148

RP	RADII		ABS-BETAM		REL BETAM		TOTAL TEMP		TOTAL PRESS	
	IN	OUT	IN	OUT	IN	OUT	IN	RATIO	IN	RATIO
1	23.904	23.884	45.2	4.8	45.2	4.8	362.3	0.994	17.27	0.937
2	23.437	23.426	42.5	4.4	42.5	4.4	356.8	0.997	17.35	0.943
3	21.542	21.603	42.7	0.9	42.7	0.9	344.9	1.000	16.40	0.962
4	20.096	20.234	47.2	-0.9	47.2	-0.9	343.7	0.995	16.05	0.953
5	19.855	20.005	48.4	-1.3	48.4	-1.3	343.3	0.994	15.91	0.958
6	19.614	19.779	49.9	-1.8	49.9	-1.8	342.8	0.994	15.81	0.962
7	19.373	19.550	52.2	-1.5	52.2	-1.5	341.8	0.996	15.58	0.972
8	19.131	19.324	53.6	-1.8	53.6	-1.8	342.7	0.994	15.50	0.975
9	17.676	17.973	46.1	0.0	46.1	0.0	337.5	0.999	15.67	0.975
10	15.735	16.215	40.2	1.2	40.2	1.2	333.7	1.000	16.46	0.936
11	15.253	15.786	40.5	4.5	40.5	4.5	333.0	1.002	16.27	0.919

RP	ABS VEL		REL VEL		MERID VEL		TANG VEL		WHEEL SPEED	
	IN	OUT	IN	OUT	IN	OUT	IN	OUT	IN	OUT
1	255.1	191.2	255.1	191.2	179.7	190.5	181.1	15.9	0.	0.
2	256.7	195.5	256.7	195.5	189.3	194.9	173.3	15.0	0.	0.
3	231.3	175.3	231.3	175.3	170.0	175.3	156.8	2.7	0.	0.
4	228.7	158.6	228.7	158.6	155.4	158.6	167.8	-2.6	0.	0.
5	225.8	157.0	225.8	157.0	149.9	156.9	168.8	-3.5	0.	0.
6	223.2	155.4	223.2	155.4	143.7	155.4	170.9	-4.8	0.	0.
7	218.7	153.8	218.7	153.8	133.9	153.7	172.9	-4.0	0.	0.
8	218.0	152.7	218.0	152.7	129.2	152.6	175.6	-4.8	0.	0.
9	232.7	161.6	232.7	161.6	161.5	161.6	167.5	0.1	0.	0.
10	264.0	176.1	264.0	176.1	201.7	176.0	170.4	3.5	0.	0.
11	265.0	161.8	265.0	161.8	201.6	161.3	172.1	12.7	0.	0.

RP	ABS MACH NO		REL MACH NO		MERID MACH NO		MERID PEAK SS	
	IN	OUT	IN	OUT	IN	OUT	VEL R	MACH NO
1	0.701	0.516	0.701	0.516	0.493	0.514	1.060	1.227
2	0.711	0.532	0.711	0.532	0.525	0.530	1.029	1.184
3	0.647	0.482	0.647	0.482	0.475	0.482	1.031	1.068
4	0.640	0.436	0.640	0.436	0.435	0.436	1.020	1.134
5	0.632	0.432	0.632	0.432	0.420	0.432	1.047	1.141
6	0.625	0.428	0.625	0.428	0.402	0.427	1.082	1.157
7	0.612	0.423	0.612	0.423	0.375	0.423	1.148	1.177
8	0.609	0.420	0.609	0.420	0.361	0.420	1.181	1.198
9	0.659	0.448	0.659	0.448	0.457	0.448	1.001	1.089
10	0.762	0.492	0.762	0.492	0.582	0.492	0.873	1.038
11	0.766	0.451	0.766	0.451	0.582	0.449	0.800	1.027

RP	PERCENT		INCIDENCE		DEV	D-FACT	EFF	LOSS COEFF		LOSS PARAM	
	SPAN	MEAN	SS	TOT				PROF	TOT	PROF	
1	5.00	17.5	11.1	13.3	0.500	0.	0.225	0.225	0.087	0.087	
2	10.00	15.4	8.9	12.5	0.472	0.	0.199	0.199	0.075	0.075	
3	30.00	15.5	9.1	8.4	0.474	0.	0.154	0.154	0.054	0.054	
4	45.00	19.1	12.7	6.5	0.548	0.	0.194	0.194	0.063	0.063	
5	47.50	20.1	13.7	6.1	0.549	0.	0.177	0.177	0.057	0.057	
6	50.00	21.4	15.0	5.6	0.553	0.	0.165	0.165	0.052	0.052	
7	52.50	23.5	17.1	5.9	0.549	0.	0.123	0.123	0.039	0.039	
8	55.00	24.7	18.3	5.6	0.555	0.	0.111	0.111	0.035	0.035	
9	70.00	15.6	9.2	7.4	0.510	0.	0.100	0.100	0.029	0.029	
10	90.00	6.7	0.4	8.7	0.492	0.	0.202	0.202	0.052	0.052	
11	95.00	5.9	-0.4	12.2	0.536	0.	0.253	0.253	0.063	0.063	

TABLE VIII. - Continued. BLADE-ELEMENT DATA AT BLADE

EDGES FOR STATOR 12

(g) 100 Percent of design speed; reading number 1179

RP	RADII		ABS BETAM		REL BETAM		TOTAL TEMP		TOTAL PRESS	
	IN	OUT	IN	OUT	IN	OUT	IN	RATIO	IN	RATIO
1	23.904	23.884	29.5	2.7	29.5	2.7	338.5	0.999	15.36	0.959
2	23.437	23.426	28.6	1.7	28.6	1.7	335.4	0.998	15.36	0.980
3	21.542	21.603	27.6	-2.5	27.6	-2.5	329.0	0.998	15.10	0.987
4	20.096	20.234	31.5	-0.6	31.5	-0.6	331.5	0.991	15.23	0.958
5	19.855	20.005	32.4	-1.2	32.4	-1.2	331.1	0.992	14.88	0.967
6	19.614	19.779	33.7	-1.9	33.7	-1.9	329.1	0.996	14.24	0.999
7	19.373	19.550	35.1	-2.5	35.1	-2.5	328.3	0.997	13.87	1.018
8	19.131	19.324	36.0	-2.8	36.0	-2.8	329.3	0.995	14.08	1.002
9	17.676	17.973	32.5	-2.0	32.5	-2.0	327.8	0.996	14.92	0.980
10	15.735	16.215	33.4	-0.8	33.4	-0.8	328.7	0.999	15.65	0.964
11	15.253	15.786	34.9	2.0	34.9	2.0	329.3	0.999	15.41	0.931

RP	ABS VEL		REL VEL		MERID VEL		TANG VEL		WHEEL SPEED	
	IN	OUT	IN	OUT	IN	OUT	IN	OUT	IN	OUT
1	256.8	210.7	256.8	210.7	223.5	210.5	126.4	9.8	0.	0.
2	256.6	218.0	256.6	218.0	225.3	217.9	122.9	6.5	0.	0.
3	247.9	214.2	247.9	214.2	219.6	214.0	115.0	-9.2	0.	0.
4	257.6	209.5	257.6	209.5	219.7	209.5	134.6	-2.0	0.	0.
5	249.1	203.9	249.1	203.9	210.3	203.9	133.5	-4.1	0.	0.
6	229.6	199.2	229.6	199.2	191.0	199.1	127.4	-6.5	0.	0.
7	218.2	196.3	218.2	196.3	178.5	196.1	125.5	-8.6	0.	0.
8	225.9	196.9	225.9	196.9	182.7	196.7	132.9	-9.6	0.	0.
9	259.4	217.3	259.4	217.3	218.8	217.2	139.3	-7.7	0.	0.
10	290.8	244.3	290.8	244.3	242.9	244.3	159.9	-3.3	0.	0.
11	285.0	227.3	285.0	227.3	233.7	227.2	163.2	7.9	0.	0.

RP	ABS MACH NO		REL MACH NO		MERID MACH NO		MERID PEAK SS	
	IN	OUT	IN	OUT	IN	OUT	VEL R	MACH NO
1	0.733	0.591	0.733	0.591	0.638	0.591	0.942	0.880
2	0.736	0.617	0.736	0.617	0.646	0.616	0.967	0.863
3	0.716	0.612	0.716	0.612	0.634	0.611	0.974	0.787
4	0.744	0.597	0.744	0.597	0.634	0.597	0.954	0.911
5	0.717	0.580	0.717	0.580	0.605	0.580	0.969	0.898
6	0.658	0.566	0.658	0.566	0.548	0.566	1.043	0.851
7	0.624	0.558	0.624	0.558	0.510	0.557	1.099	0.833
8	0.647	0.560	0.647	0.560	0.523	0.559	1.076	0.880
9	0.754	0.623	0.754	0.623	0.636	0.622	0.993	0.884
10	0.857	0.705	0.857	0.705	0.716	0.705	1.006	0.932
11	0.837	0.651	0.837	0.651	0.686	0.651	0.972	0.937

RP	PERCENT SPAN	INCIDENCE		DEV	D-FACT	EFF	LOSS COEFF		LOSS PARAM	
		MEAN	SS				TOT	PROF	TOT	PROF
1	5.00	1.8	-4.6	11.2	0.355	0.	0.136	0.136	0.052	0.052
2	10.00	1.5	-4.9	9.8	0.322	0.	0.066	0.066	0.025	0.025
3	30.00	0.5	-6.0	5.1	0.310	0.	0.044	0.044	0.015	0.015
4	45.00	3.4	-3.0	6.8	0.359	0.	0.138	0.138	0.045	0.045
5	47.50	4.1	-2.3	6.2	0.358	0.	0.115	0.115	0.037	0.037
6	50.00	5.2	-1.2	5.5	0.317	0.	0.005	0.005	0.001	0.001
7	52.50	6.3	-0.1	4.9	0.292	0.	-0.078	-0.078	-0.024	-0.024
8	55.00	7.0	0.6	4.6	0.323	0.	-0.009	-0.009	-0.003	-0.003
9	70.00	2.0	-4.4	5.3	0.324	0.	0.063	0.063	0.018	0.018
10	90.00	-0.1	-6.5	6.8	0.301	0.	0.094	0.094	0.024	0.024
11	95.00	0.3	-6.0	9.7	0.335	0.	0.187	0.187	0.046	0.046

TABLE VIII. - Continued. BLADE-ELEMENT DATA AT BLADE

EDGES FOR STATOR 12

(h) 90 Percent of design speed; reading number 1151

RP	RADII		ABS BETAM		REL BETAM		TOTAL TEMP		TOTAL PRESS	
	IN	OUT	IN	OUT	IN	OUT	IN	RATIO	IN	RATIO
1	23.904	23.884	20.9	-0.4	20.9	-0.4	320.3	1.002	13.40	0.945
2	23.437	23.426	20.6	-1.8	20.6	-1.8	318.5	1.000	13.34	0.975
3	21.542	21.603	21.2	-4.2	21.2	-4.2	315.4	0.999	13.25	0.979
4	20.096	20.234	24.5	-3.8	24.5	-3.8	318.1	0.995	13.57	0.968
5	19.855	20.005	25.0	-3.9	25.0	-3.9	318.2	0.995	13.56	0.966
6	19.614	19.779	25.4	-3.9	25.4	-3.9	317.0	0.998	13.32	0.978
7	19.373	19.550	26.4	-4.1	26.4	-4.1	317.6	0.998	13.08	0.995
8	19.131	19.324	27.3	-4.0	27.3	-4.0	318.0	0.998	13.09	0.996
9	17.676	17.973	26.1	-4.3	26.1	-4.3	317.1	1.000	13.78	0.971
10	15.735	16.215	29.4	-2.4	29.4	-2.4	319.0	0.999	14.13	0.964
11	15.253	15.786	30.8	1.3	30.8	1.3	319.8	0.997	14.27	0.909

RP	ABS VEL		REL VEL		MERID VEL		TANG VEL		WHEEL SPEED	
	IN	OUT	IN	OUT	IN	OUT	IN	OUT	IN	OUT
1	242.8	215.4	242.8	215.4	226.7	215.4	86.8	-1.5	0.	0.
2	239.8	225.0	239.8	225.0	224.4	224.9	84.5	-6.9	0.	0.
3	230.9	224.2	230.9	224.2	215.3	223.6	83.5	-16.5	0.	0.
4	241.9	232.8	241.9	232.8	220.1	232.3	100.5	-15.2	0.	0.
5	241.6	232.4	241.6	232.4	218.9	231.9	102.1	-15.9	0.	0.
6	233.7	231.0	233.7	231.0	211.1	230.5	100.3	-15.7	0.	0.
7	225.3	231.6	225.3	231.6	201.9	231.0	100.0	-16.5	0.	0.
8	226.0	232.6	226.0	232.6	200.7	232.1	103.8	-16.1	0.	0.
9	251.9	248.4	251.9	248.4	226.2	247.7	110.9	-18.5	0.	0.
10	271.7	277.6	271.7	277.6	236.7	277.4	133.4	-11.6	0.	0.
11	273.9	264.2	273.9	264.2	235.3	264.1	140.2	6.1	0.	0.

RP	ABS MACH NO		REL MACH NO		MERID MACH NO		MERID PEAK SS	
	IN	OUT	IN	OUT	IN	OUT	VEL R	MACH NO
1	0.710	0.623	0.710	0.623	0.663	0.623	0.950	0.710
2	0.703	0.655	0.703	0.655	0.657	0.655	1.002	0.703
3	0.678	0.657	0.678	0.657	0.632	0.655	1.039	0.678
4	0.710	0.682	0.710	0.682	0.646	0.681	1.055	0.710
5	0.709	0.681	0.709	0.681	0.642	0.679	1.059	0.709
6	0.685	0.677	0.685	0.677	0.619	0.675	1.092	0.685
7	0.657	0.678	0.657	0.678	0.589	0.676	1.144	0.657
8	0.659	0.681	0.659	0.681	0.585	0.680	1.156	0.659
9	0.744	0.732	0.744	0.732	0.668	0.730	1.095	0.744
10	0.807	0.827	0.807	0.827	0.703	0.826	1.172	0.807
11	0.813	0.782	0.813	0.782	0.698	0.782	1.122	0.813

RP	PERCENT	INCIDENCE		DEV	D-FACT	EFF	LOSS COEFF		LOSS PARAM	
	SPAN	MEAN	SS				TOT	PROF	TOT	PROF
1	5.00	-6.8	-13.2	8.1	0.253	0.	0.194	0.194	0.075	0.075
2	10.00	-6.5	-12.9	6.3	0.206	0.	0.088	0.088	0.033	0.033
3	30.00	-6.0	-12.4	3.3	0.180	0.	0.080	0.080	0.028	0.028
4	45.00	-3.6	-10.0	3.6	0.193	0.	0.112	0.112	0.036	0.036
5	47.50	-3.3	-9.7	3.5	0.195	0.	0.119	0.119	0.038	0.038
6	50.00	-3.1	-9.5	3.5	0.169	0.	0.081	0.081	0.026	0.026
7	52.50	-2.4	-8.8	3.3	0.134	0.	0.018	0.018	0.006	0.006
8	55.00	-1.6	-8.0	3.4	0.134	0.	0.015	0.015	0.005	0.005
9	70.00	-4.4	-10.8	3.1	0.161	0.	0.094	0.094	0.027	0.027
10	90.00	-4.1	-10.4	5.2	0.113	0.	0.103	0.103	0.026	0.026
11	95.00	-3.8	-10.1	9.0	0.155	0.	0.258	0.258	0.064	0.064

TABLE VIII. - Continued. BLADE-ELEMENT DATA AT BLADE

EDGES FOR STATOR 12

(i) 90 Percent of design speed; reading number 1152

RP	RAD II		ABS. BETAM		REL BETAM		TOTAL TEMP		TOTAL PRESS	
	IN	OUT	IN	OUT	IN	OUT	IN	RATIO	IN	RATIO
1	23.904	23.884	29.0	0.7	29.0	0.7	330.5	0.996	14.63	0.970
2	23.437	23.426	27.4	0.4	27.4	0.4	327.2	0.998	14.62	0.978
3	21.542	21.603	28.2	-3.3	28.2	-3.3	322.0	0.998	14.28	0.987
4	20.096	20.234	29.2	-3.0	29.2	-3.0	322.0	0.998	14.38	0.980
5	19.855	20.005	29.6	-2.8	29.6	-2.8	322.5	0.997	14.39	0.978
6	19.614	19.779	31.2	-2.5	31.2	-2.5	322.7	0.998	14.34	0.979
7	19.373	19.550	32.6	-2.4	32.6	-2.4	323.4	0.996	14.13	0.992
8	19.131	19.324	33.7	-2.5	33.7	-2.5	323.1	0.997	14.05	0.994
9	17.676	17.973	31.8	-3.5	31.8	-3.5	321.0	0.998	14.28	0.984
10	15.735	16.215	34.7	-2.8	34.7	-2.8	322.0	0.999	14.49	0.977
11	15.253	15.786	35.6	-0.2	35.6	-0.2	322.5	0.999	14.67	0.938

RP	ABS VEL		REL VEL		MERID VEL		TANG VEL		WHEEL SPEED	
	IN	OUT	IN	OUT	IN	OUT	IN	OUT	IN	OUT
1	236.2	194.7	236.2	194.7	206.6	194.7	114.3	2.3	0.	0.
2	234.8	197.1	234.8	197.1	208.5	197.1	108.0	1.2	0.	0.
3	221.1	191.0	221.1	191.0	194.8	190.6	104.6	-10.9	0.	0.
4	228.6	193.4	228.6	193.4	199.6	193.2	111.4	-10.2	0.	0.
5	229.8	193.1	229.8	193.1	199.7	192.9	113.7	-9.3	0.	0.
6	228.4	193.1	228.4	193.1	195.3	192.9	118.3	-8.5	0.	0.
7	222.5	192.5	222.5	192.5	187.4	192.4	120.0	-8.0	0.	0.
8	220.7	191.6	220.7	191.6	183.7	191.4	122.3	-8.4	0.	0.
9	234.5	198.5	234.5	198.5	199.2	198.1	123.7	-12.2	0.	0.
10	250.9	214.3	250.9	214.3	206.3	214.1	142.7	-10.6	0.	0.
11	257.5	205.0	257.5	205.0	209.5	205.0	149.7	-0.6	0.	0.

RP	ABS MACH NO		REL MACH NO		MERID MACH NO		MERID PEAK SS	
	IN	OUT	IN	OUT	IN	OUT	VEL R	MACH NO
1	0.677	0.551	0.677	0.551	0.592	0.551	0.942	0.798
2	0.677	0.561	0.677	0.561	0.601	0.561	0.946	0.756
3	0.639	0.547	0.639	0.547	0.563	0.546	0.979	0.722
4	0.663	0.554	0.663	0.554	0.579	0.554	0.968	0.746
5	0.666	0.553	0.666	0.553	0.579	0.553	0.966	0.759
6	0.661	0.553	0.661	0.553	0.566	0.552	0.987	0.791
7	0.642	0.551	0.642	0.551	0.541	0.551	1.027	0.799
8	0.637	0.548	0.637	0.548	0.530	0.548	1.042	0.812
9	0.683	0.571	0.683	0.571	0.580	0.570	0.995	0.781
10	0.734	0.619	0.734	0.619	0.604	0.618	1.038	0.845
11	0.755	0.589	0.755	0.589	0.614	0.589	0.978	0.867

RP	PERCENT	INCIDENCE		DEV	D-FACT	EFF	LOSS COEFF		LOSS PARAM	
	SPAN	MEAN	SS				TOT	PROF	TOT	PROF
1	5.00	1.2	-5.2	9.2	0.359	0.	0.112	0.112	0.043	0.043
2	10.00	0.3	-6.2	8.5	0.333	0.	0.084	0.084	0.032	0.032
3	30.00	1.1	-5.4	4.2	0.318	0.	0.054	0.054	0.019	0.019
4	45.00	1.1	-5.4	4.4	0.327	0.	0.079	0.079	0.026	0.026
5	47.50	1.3	-5.1	4.6	0.331	0.	0.087	0.087	0.028	0.028
6	50.00	2.7	-3.7	4.8	0.330	0.	0.081	0.081	0.026	0.026
7	52.50	3.9	-2.5	5.0	0.314	0.	0.035	0.035	0.011	0.011
8	55.00	4.7	-1.7	4.9	0.315	0.	0.027	0.027	0.008	0.008
9	70.00	1.4	-5.0	3.8	0.319	0.	0.058	0.058	0.017	0.017
10	90.00	1.2	-5.1	4.8	0.300	0.	0.075	0.075	0.019	0.019
11	95.00	1.0	-5.3	7.5	0.346	0.	0.196	0.196	0.049	0.049

TABLE VIII. - Continued. BLADE-ELEMENT DATA AT BLADE

EDGES FOR STATOR 12

(j) 90 Percent of design speed; reading number 1153

RP	RADII		ABS BETAM		REL BETAM		TOTAL TEMP		TOTAL PRESS	
	IN	OUT	IN	OUT	IN	OUT	IN	RATIO	IN	RATIO
1	23.904	23.884	33.1	1.4	33.1	1.4	337.9	0.989	15.35	0.959
2	23.437	23.426	32.7	1.4	32.7	1.4	333.6	0.996	15.32	0.976
3	21.542	21.603	32.1	-2.2	32.1	-2.2	325.8	0.999	14.82	0.985
4	20.096	20.234	33.2	-2.1	33.2	-2.1	324.7	0.998	14.67	0.979
5	19.855	20.005	34.2	-2.0	34.2	-2.0	324.7	0.998	14.65	0.978
6	19.614	19.779	35.2	-1.9	35.2	-1.9	325.3	0.997	14.63	0.974
7	19.373	19.550	37.6	-1.8	37.6	-1.8	325.7	0.996	14.38	0.986
8	19.131	19.324	38.9	-1.9	38.9	-1.9	325.7	0.996	14.27	0.990
9	17.676	17.973	38.7	-2.6	38.7	-2.6	324.2	0.997	14.32	0.983
10	15.735	16.215	37.7	-2.0	37.7	-2.0	323.8	0.999	14.90	0.966
11	15.253	15.786	38.1	0.3	38.1	0.3	323.9	1.000	14.84	0.945

RP	ABS VEL		REL VEL		MERID VEL		TANG VEL		WHEEL SPEED	
	IN	OUT	IN	OUT	IN	OUT	IN	OUT	IN	OUT
1	236.6	183.7	236.6	183.7	198.2	183.6	129.2	4.5	0.	0.
2	234.8	190.6	234.8	190.6	197.6	190.5	126.9	4.6	0.	0.
3	217.3	178.8	217.3	178.8	184.1	178.7	115.5	-6.7	0.	0.
4	218.4	173.3	218.4	173.3	182.8	173.2	119.5	-6.4	0.	0.
5	218.2	172.4	218.2	172.4	180.4	172.3	122.8	-6.2	0.	0.
6	218.7	170.8	218.7	170.8	178.7	170.7	126.1	-5.8	0.	0.
7	212.1	168.5	212.1	168.5	168.1	168.4	129.3	-5.4	0.	0.
8	209.6	166.9	209.6	166.9	163.0	166.8	131.8	-5.5	0.	0.
9	218.7	169.4	218.7	169.4	170.6	169.2	136.8	-7.8	0.	0.
10	245.7	190.7	245.7	190.7	194.3	190.6	150.3	-6.8	0.	0.
11	247.6	180.2	247.6	180.2	194.9	180.2	152.6	1.0	0.	0.

RP	ABS MACH NO		REL MACH NO		MERID MACH NO		MERID PEAK SS	
	IN	OUT	IN	OUT	IN	OUT	VEL R	MACH NO
1	0.670	0.514	0.670	0.514	0.561	0.514	0.927	0.897
2	0.669	0.536	0.669	0.536	0.563	0.536	0.964	0.890
3	0.624	0.507	0.624	0.507	0.528	0.507	0.971	0.802
4	0.628	0.492	0.628	0.492	0.526	0.491	0.948	0.809
5	0.628	0.489	0.628	0.489	0.519	0.489	0.955	0.828
6	0.628	0.484	0.628	0.484	0.513	0.484	0.955	0.847
7	0.608	0.477	0.608	0.477	0.482	0.477	1.002	0.864
8	0.600	0.472	0.600	0.472	0.467	0.472	1.023	0.877
9	0.629	0.481	0.629	0.481	0.491	0.480	0.991	0.884
10	0.715	0.545	0.715	0.545	0.566	0.544	0.981	0.911
11	0.721	0.512	0.721	0.512	0.568	0.512	0.924	0.902

RP	PERCENT		INCIDENCE		DEV	D-FACT	EFF	LOSS COEFF		LOSS PARAM	
	SPAN	MEAN	SS	TOT				PROF	TOT	PROF	
1	5.00	5.4	-1.0	9.9	0.427	0.	0.157	0.157	0.060	0.060	
2	10.00	5.6	-0.8	9.5	0.385	0.	0.091	0.091	0.035	0.035	
3	30.00	4.9	-1.5	5.3	0.373	0.	0.064	0.064	0.022	0.022	
4	45.00	5.1	-1.3	5.3	0.393	0.	0.091	0.091	0.030	0.030	
5	47.50	5.9	-0.5	5.3	0.399	0.	0.096	0.096	0.031	0.031	
6	50.00	6.7	0.3	5.4	0.410	0.	0.110	0.110	0.035	0.035	
7	52.50	8.8	2.4	5.5	0.404	0.	0.065	0.065	0.020	0.020	
8	55.00	10.0	3.6	5.5	0.406	0.	0.047	0.047	0.015	0.015	
9	70.00	8.2	1.9	4.7	0.414	0.	0.073	0.073	0.021	0.021	
10	90.00	4.2	-2.1	5.6	0.385	0.	0.117	0.117	0.030	0.030	
11	95.00	3.5	-2.8	8.0	0.421	0.	0.187	0.187	0.047	0.047	

TABLE VIII. - Continued. BLADE-ELEMENT DATA AT BLADE

EDGES FOR STATOR 12

(k) 90 Percent of design speed; reading number 1154

RP	RADII		ABS BETAM		REL BETAM		TOTAL TEMP		TOTAL PRESS	
	IN	OUT	IN	OUT	IN	OUT	IN	RATIO	IN	RATIO
1	23.904	23.884	36.8	2.0	36.8	2.0	342.0	0.992	15.57	0.964
2	23.437	23.426	35.8	2.1	35.8	2.1	338.1	0.993	15.64	0.970
3	21.542	21.603	34.9	-1.2	34.9	-1.2	328.2	0.999	14.84	0.983
4	20.096	20.234	39.3	-1.0	39.3	-1.0	327.8	0.996	14.62	0.971
5	19.855	20.005	40.3	-1.0	40.3	-1.0	327.9	0.996	14.59	0.969
6	19.614	19.779	42.0	-1.0	42.0	-1.0	328.4	0.995	14.51	0.973
7	19.373	19.550	44.0	-0.6	44.0	-0.6	328.6	0.994	14.35	0.981
8	19.131	19.324	46.0	-0.9	46.0	-0.9	328.7	0.994	14.26	0.985
9	17.676	17.973	42.3	-1.2	42.3	-1.2	326.4	0.997	14.46	0.978
10	15.735	16.215	38.1	-1.0	38.1	-1.0	324.0	1.000	15.04	0.962
11	15.253	15.786	38.7	1.5	38.7	1.5	323.6	1.002	14.88	0.941

RP	ABS VEL		REL VEL		MERID VEL		TANG VEL		WHEEL SPEED	
	IN	OUT	IN	OUT	IN	OUT	IN	OUT	IN	OUT
1	235.2	182.4	235.2	182.4	188.2	182.3	141.0	6.4	0.	0.
2	236.0	187.4	236.0	187.4	191.5	187.3	138.0	6.8	0.	0.
3	211.6	167.3	211.6	167.3	173.7	167.2	121.0	-3.6	0.	0.
4	209.6	154.9	209.6	154.9	162.2	154.9	132.8	-2.7	0.	0.
5	209.3	153.2	209.3	153.2	159.7	153.2	135.2	-2.7	0.	0.
6	207.6	152.4	207.6	152.4	154.1	152.4	139.0	-2.6	0.	0.
7	203.6	151.1	203.6	151.1	146.5	151.1	141.3	-1.6	0.	0.
8	202.2	150.6	202.2	150.6	140.6	150.6	145.4	-2.5	0.	0.
9	216.1	157.9	216.1	157.9	159.7	157.9	145.6	-3.4	0.	0.
10	243.6	179.5	243.6	179.5	191.7	179.5	150.3	-3.1	0.	0.
11	243.4	163.7	243.4	163.7	190.0	163.7	152.1	4.2	0.	0.

RP	ABS MACH NO		REL MACH NO		MERID MACH NO		MERID PEAK SS	
	IN	OUT	IN	OUT	IN	OUT	VEL R	MACH NO
1	0.662	0.507	0.662	0.507	0.530	0.506	0.968	0.970
2	0.668	0.524	0.668	0.524	0.542	0.524	0.978	0.960
3	0.604	0.471	0.604	0.471	0.495	0.471	0.963	0.836
4	0.598	0.436	0.598	0.436	0.463	0.436	0.955	0.899
5	0.597	0.431	0.597	0.431	0.455	0.431	0.959	0.912
6	0.591	0.428	0.591	0.428	0.439	0.428	0.988	0.935
7	0.579	0.424	0.579	0.424	0.417	0.424	1.031	0.949
8	0.575	0.423	0.575	0.423	0.399	0.423	1.072	0.977
9	0.619	0.445	0.619	0.445	0.458	0.445	0.989	0.946
10	0.708	0.510	0.708	0.510	0.557	0.510	0.937	0.912
11	0.708	0.463	0.708	0.463	0.553	0.463	0.862	0.903

RP	PERCENT	INCIDENCE		DEV	D-FACT	EFF	LOSS COEFF		LOSS PARAM	
	SPAN	MEAN	SS				TOT	PROF	TOT	PROF
1	5.00	9.1	2.7	10.5	0.445	0.	0.142	0.142	0.055	0.055
2	10.00	8.7	2.2	10.2	0.416	0.	0.115	0.115	0.044	0.044
3	30.00	7.7	1.3	6.3	0.415	0.	0.080	0.080	0.028	0.028
4	45.00	11.2	4.8	6.4	0.471	0.	0.136	0.136	0.044	0.044
5	47.50	12.0	5.5	6.4	0.479	0.	0.144	0.144	0.046	0.046
6	50.00	13.5	7.1	6.4	0.482	0.	0.129	0.129	0.041	0.041
7	52.50	15.2	8.8	6.8	0.477	0.	0.094	0.094	0.029	0.029
8	55.00	17.0	10.6	6.4	0.481	0.	0.074	0.074	0.023	0.023
9	70.00	11.9	5.5	6.1	0.465	0.	0.096	0.096	0.027	0.027
10	90.00	4.6	-1.7	6.6	0.422	0.	0.134	0.134	0.034	0.034
11	95.00	4.1	-2.2	9.2	0.475	0.	0.208	0.208	0.052	0.052

TABLE VIII. - Continued. BLADE-ELEMENT DATA AT BLADE

EDGES FOR STATOR 12

(1) 90 Percent of design speed; reading number 1155

RP	RADII		ABS BETAM		REL BETAM		TOTAL TEMP		TOTAL PRESS	
	IN	OUT	IN	OUT	IN	OUT	IN	RATIO	IN	RATIO
1	23.904	23.884	40.3	3.2	40.3	3.2	342.5	0.998	15.47	0.961
2	23.437	23.426	38.8	3.6	38.8	3.6	339.5	0.997	15.52	0.970
3	21.542	21.603	39.5	0.2	39.5	0.2	331.0	0.999	14.81	0.976
4	20.096	20.234	44.3	-0.2	44.3	-0.2	330.9	0.995	14.66	0.965
5	19.855	20.005	45.6	-0.3	45.6	-0.3	330.9	0.995	14.61	0.966
6	19.614	19.779	47.0	-0.5	47.0	-0.5	330.6	0.995	14.47	0.973
7	19.373	19.550	48.7	-0.7	48.7	-0.7	330.4	0.995	14.35	0.979
8	19.131	19.324	50.4	-0.8	50.4	-0.8	330.5	0.995	14.28	0.982
9	17.676	17.973	44.0	0.1	44.0	0.1	327.5	0.998	14.52	0.980
10	15.735	16.215	38.4	-0.3	38.4	-0.3	324.1	1.001	15.11	0.955
11	15.253	15.786	39.2	2.7	39.2	2.7	323.6	1.002	14.91	0.942

RP	ABS VEL		REL VEL		MERID VEL		TANG VEL		WHEEL SPEED	
	IN	OUT	IN	OUT	IN	OUT	IN	OUT	IN	OUT
1	228.2	173.7	228.2	173.7	174.0	173.4	147.7	9.8	0.	0.
2	228.9	179.5	228.9	179.5	178.5	179.1	143.3	11.2	0.	0.
3	206.5	157.5	206.5	157.5	159.4	157.5	131.2	0.7	0.	0.
4	207.1	146.6	207.1	146.6	148.2	146.6	144.7	-0.5	0.	0.
5	205.9	144.9	205.9	144.9	144.0	144.9	147.2	-0.8	0.	0.
6	202.1	144.1	202.1	144.1	137.8	144.1	147.8	-1.2	0.	0.
7	199.2	143.0	199.2	143.0	131.6	143.0	149.5	-1.7	0.	0.
8	198.4	142.6	198.4	142.6	126.6	142.6	152.8	-2.1	0.	0.
9	214.4	154.6	214.4	154.6	154.3	154.6	148.9	0.2	0.	0.
10	241.4	171.1	241.4	171.1	189.2	171.1	150.0	-0.8	0.	0.
11	240.2	158.2	240.2	158.2	186.2	158.0	151.8	7.5	0.	0.

RP	ABS MACH NO		REL MACH NO		MERID MACH NO		MERID PEAK SS	
	IN	OUT	IN	OUT	IN	OUT	VEL R	MACH NO
1	0.640	0.479	0.640	0.479	0.488	0.478	0.996	1.014
2	0.645	0.499	0.645	0.499	0.503	0.498	1.003	0.992
3	0.585	0.440	0.585	0.440	0.452	0.440	0.988	0.903
4	0.587	0.410	0.587	0.410	0.420	0.410	0.989	0.982
5	0.584	0.405	0.584	0.405	0.408	0.405	1.006	0.998
6	0.572	0.403	0.572	0.403	0.390	0.403	1.046	1.002
7	0.564	0.400	0.564	0.400	0.372	0.400	1.087	1.014
8	0.561	0.399	0.561	0.399	0.358	0.399	1.127	1.039
9	0.613	0.435	0.613	0.435	0.441	0.435	1.002	0.970
10	0.701	0.485	0.701	0.485	0.549	0.485	0.904	0.911
11	0.698	0.447	0.698	0.447	0.541	0.446	0.848	0.903

RP	PERCENT SPAN	INCIDENCE		DEV	D-FACT	EFF	LOSS COEFF		LOSS PARAM	
		MEAN	SS				TOT	PROF	TOT	PROF
1	5.00	12.6	6.2	11.8	0.472	0.	0.163	0.163	0.063	0.063
2	10.00	11.6	5.2	11.7	0.434	0.	0.124	0.124	0.047	0.047
3	30.00	12.3	5.9	7.7	0.457	0.	0.115	0.115	0.040	0.040
4	45.00	16.2	9.8	7.2	0.519	0.	0.166	0.166	0.054	0.054
5	47.50	17.3	10.9	7.1	0.526	0.	0.167	0.167	0.054	0.054
6	50.00	18.5	12.1	6.9	0.520	0.	0.134	0.134	0.043	0.043
7	52.50	19.9	13.5	6.7	0.519	0.	0.108	0.108	0.034	0.034
8	55.00	21.4	15.0	6.5	0.522	0.	0.092	0.092	0.028	0.028
9	70.00	13.5	7.1	7.4	0.476	0.	0.088	0.088	0.025	0.025
10	90.00	4.9	-1.4	7.3	0.449	0.	0.162	0.162	0.042	0.042
11	95.00	4.6	-1.7	10.4	0.488	0.	0.208	0.208	0.052	0.052

TABLE VIII. - Continued. BLADE-ELEMENT DATA AT BLADE

EDGES FOR STATOR 12

(m) 90 Percent of design speed; reading number 1156

RP	RADII		ABS BETAM		REL BETAM		TOTAL TEMP		TOTAL PRESS	
	IN	OUT	IN	OUT	IN	OUT	IN	RATIO	IN	RATIO
1	23.904	23.884	50.6	4.2	50.6	4.2	349.6	0.989	15.33	0.944
2	23.437	23.426	45.7	4.0	45.7	4.0	345.4	0.994	15.36	0.946
3	21.542	21.603	46.2	0.8	46.2	0.8	335.3	1.000	14.83	0.969
4	20.096	20.234	48.8	-1.0	48.8	-1.0	333.8	0.996	14.72	0.960
5	19.855	20.005	49.5	-1.3	49.5	-1.3	333.5	0.996	14.63	0.964
6	19.614	19.779	50.7	-1.8	50.7	-1.8	333.0	0.996	14.51	0.970
7	19.373	19.550	52.2	-2.0	52.2	-2.0	332.5	0.997	14.39	0.977
8	19.131	19.324	53.7	-2.2	53.7	-2.2	331.9	0.997	14.31	0.982
9	17.676	17.973	45.4	0.4	45.4	0.4	328.8	0.998	14.66	0.978
10	15.735	16.215	38.7	0.6	38.7	0.6	324.3	1.002	15.16	0.951
11	15.253	15.786	39.5	3.9	39.5	3.9	323.8	1.003	15.00	0.938

RP	ABS VEL		REL VEL		MERID VEL		TANG VEL		WHEEL SPEED	
	IN	OUT	IN	OUT	IN	OUT	IN	OUT	IN	OUT
1	219.2	158.9	219.2	158.9	139.2	158.4	169.3	11.8	0.	0.
2	220.2	160.7	220.2	160.7	153.8	160.3	157.6	11.3	0.	0.
3	204.2	153.3	204.2	153.3	141.4	153.3	147.3	2.1	0.	0.
4	206.2	142.5	206.2	142.5	135.7	142.5	155.2	-2.4	0.	0.
5	203.7	141.2	203.7	141.2	132.2	141.2	155.0	-3.2	0.	0.
6	200.4	140.6	200.4	140.6	126.9	140.5	155.1	-4.4	0.	0.
7	197.3	140.2	197.3	140.2	120.9	140.1	155.9	-4.9	0.	0.
8	195.8	139.9	195.8	139.9	116.0	139.8	157.8	-5.3	0.	0.
9	216.0	155.0	216.0	155.0	151.6	155.0	153.8	1.1	0.	0.
10	239.2	166.7	239.2	166.7	186.6	166.7	149.6	1.6	0.	0.
11	239.3	154.6	239.3	154.6	184.6	154.2	152.3	10.6	0.	0.

RP	ABS MACH NO		REL MACH NO		MERID MACH NO		MERID PEAK SS	
	IN	OUT	IN	OUT	IN	OUT	VEL R	MACH NO
1	0.606	0.434	0.606	0.434	0.385	0.435	1.138	1.174
2	0.613	0.441	0.613	0.441	0.428	0.440	1.042	1.087
3	0.574	0.425	0.574	0.425	0.398	0.425	1.084	1.017
4	0.582	0.396	0.582	0.396	0.383	0.396	1.050	1.063
5	0.575	0.393	0.575	0.393	0.373	0.392	1.068	1.060
6	0.565	0.391	0.565	0.391	0.358	0.391	1.108	1.062
7	0.556	0.390	0.556	0.390	0.341	0.390	1.159	1.070
8	0.552	0.389	0.552	0.389	0.327	0.389	1.205	1.087
9	0.616	0.435	0.616	0.435	0.433	0.435	1.023	1.006
10	0.694	0.471	0.694	0.471	0.541	0.471	0.893	0.909
11	0.695	0.436	0.695	0.436	0.536	0.435	0.835	0.907

RP	PERCENT SPAN		INCIDENCE		DEV	D-FACT	EFF	LOSS COEFF		LOSS PARAM	
	SPAN	MEAN	SS	TOT				PROF	TOT	PROF	
1	5.00	22.8	16.4	12.8	0.553	0.	0.254	0.254	0.098	0.098	
2	10.00	18.6	12.1	12.1	0.522	0.	0.241	0.241	0.091	0.091	
3	30.00	19.0	12.6	8.3	0.496	0.	0.154	0.154	0.054	0.054	
4	45.00	20.7	14.3	6.4	0.557	0.	0.197	0.197	0.064	0.064	
5	47.50	21.2	14.8	6.1	0.556	0.	0.181	0.181	0.058	0.058	
6	50.00	22.2	15.8	5.6	0.550	0.	0.152	0.152	0.048	0.048	
7	52.50	23.5	17.0	5.4	0.544	0.	0.119	0.119	0.037	0.037	
8	55.00	24.7	18.3	5.2	0.543	0.	0.097	0.097	0.030	0.030	
9	70.00	14.9	8.6	7.8	0.483	0.	0.098	0.098	0.028	0.028	
10	90.00	5.2	-1.1	8.1	0.459	0.	0.177	0.177	0.045	0.045	
11	95.00	4.9	-1.4	11.6	0.498	0.	0.225	0.225	0.056	0.056	

TABLE VIII. - Continued. BLADE-ELEMENT DATA AT BLADE

EDGES FOR STATOR 12

(n) 80 Percent of design speed; reading number 1157

RP	RADII		ABS BETAM		REL BETAM		TOTAL TEMP		TOTAL PRESS	
	IN	OUT	IN	OUT	IN	OUT	IN	RATIO	IN	RATIO
1	23.904	23.884	50.7	3.8	50.7	3.8	336.7	0.989	14.06	0.956
2	23.437	23.426	45.0	3.6	45.0	3.6	332.5	0.995	14.05	0.962
3	21.542	21.603	44.6	1.0	44.6	1.0	324.6	1.000	13.73	0.981
4	20.096	20.234	46.1	-0.0	46.1	-0.0	323.4	0.997	13.73	0.969
5	19.855	20.005	46.6	-0.4	46.6	-0.4	323.4	0.997	13.69	0.971
6	19.614	19.779	47.8	-0.3	47.8	-0.3	322.9	0.998	13.58	0.978
7	19.373	19.550	49.1	-0.8	49.1	-0.8	322.5	0.998	13.51	0.981
8	19.131	19.324	50.6	-1.0	50.6	-1.0	322.4	0.998	13.44	0.985
9	17.676	17.973	44.6	0.0	44.6	0.0	320.3	0.998	13.69	0.979
10	15.735	16.215	38.9	-0.2	38.9	-0.2	317.0	1.001	14.03	0.960
11	15.253	15.786	39.5	2.9	39.5	2.9	316.6	1.002	13.86	0.953

RP	ABS VEL		REL VEL		MERID VEL		TANG VEL		WHEEL SPEED	
	IN	OUT	IN	OUT	IN	OUT	IN	OUT	IN	OUT
1	192.8	137.6	192.8	137.6	122.1	137.3	149.2	9.2	0.	0.
2	192.2	141.3	192.2	141.3	135.8	141.0	136.0	8.8	0.	0.
3	181.1	138.0	181.1	138.0	129.0	137.9	127.1	2.3	0.	0.
4	185.4	131.3	185.4	131.3	128.5	131.3	133.6	-0.1	0.	0.
5	184.4	130.5	184.4	130.5	126.8	130.5	133.9	-1.0	0.	0.
6	180.9	130.0	180.9	130.0	121.7	130.0	133.9	-0.6	0.	0.
7	178.9	129.2	178.9	129.2	117.1	129.2	135.3	-1.9	0.	0.
8	177.6	129.0	177.6	129.0	112.7	129.0	137.3	-2.3	0.	0.
9	193.9	138.8	193.9	138.8	138.0	138.8	136.2	0.1	0.	0.
10	213.2	149.5	213.2	149.5	166.0	149.5	133.8	-0.6	0.	0.
11	211.7	139.2	211.7	139.2	163.2	139.1	134.8	7.0	0.	0.

RP	ABS MACH NO		REL MACH NO		MERID MACH NO		MERID PEAK SS	
	IN	OUT	IN	OUT	IN	OUT	VEL R	MACH NO
1	0.539	0.382	0.539	0.382	0.341	0.381	1.125	1.048
2	0.541	0.394	0.541	0.394	0.382	0.393	1.038	0.948
3	0.514	0.388	0.514	0.388	0.366	0.388	1.070	0.883
4	0.528	0.370	0.528	0.370	0.366	0.370	1.021	0.916
5	0.525	0.367	0.525	0.367	0.361	0.367	1.030	0.916
6	0.516	0.366	0.516	0.366	0.347	0.366	1.069	0.915
7	0.510	0.364	0.510	0.364	0.334	0.364	1.104	0.925
8	0.506	0.364	0.506	0.364	0.321	0.363	1.145	0.941
9	0.557	0.393	0.557	0.393	0.396	0.393	1.006	0.895
10	0.620	0.426	0.620	0.426	0.483	0.426	0.900	0.816
11	0.616	0.396	0.616	0.396	0.475	0.396	0.852	0.804

RP	PERCENT		INCIDENCE		DEV	D-FACT	EFF	LOSS COEFF		LOSS PARAM	
	SPAN	MEAN	SS	TOT				PROF	TOT	PROF	
1	5.00	23.0	16.6	12.4	0.566	0.	0.244	0.244	0.094	0.094	
2	10.00	17.9	11.5	11.7	0.516	0.	0.209	0.209	0.079	0.079	
3	30.00	17.4	11.0	8.5	0.478	0.	0.116	0.116	0.040	0.040	
4	45.00	18.0	11.6	7.4	0.526	0.	0.178	0.178	0.058	0.058	
5	47.50	18.3	11.9	7.0	0.527	0.	0.171	0.171	0.055	0.055	
6	50.00	19.2	12.8	7.1	0.517	0.	0.134	0.134	0.043	0.043	
7	52.50	20.4	14.0	6.5	0.517	0.	0.114	0.114	0.036	0.036	
8	55.00	21.6	15.2	6.4	0.516	0.	0.092	0.092	0.028	0.028	
9	70.00	14.2	7.8	7.4	0.484	0.	0.110	0.110	0.032	0.032	
10	90.00	5.4	-0.9	7.3	0.458	0.	0.175	0.175	0.045	0.045	
11	95.00	5.0	-1.3	10.6	0.489	0.	0.207	0.207	0.051	0.051	

TABLE VIII. - Continued. BLADE-ELEMENT DATA AT BLADE

EDGES FOR STATOR 12

(o) 70 Percent of design speed; reading number 1173

RP	RADII		ABS BETAM		REL BETAM		TOTAL TEMP		TOTAL PRESS	
	IN	OUT	IN	OUT	IN	OUT	IN	RATIO	IN	RATIO
1	23.904	23.884	18.1	0.5	18.1	0.5	304.4	1.001	11.75	0.968
2	23.437	23.426	17.8	-0.6	17.8	-0.6	303.2	1.001	11.76	0.991
3	21.542	21.603	18.7	-3.0	18.7	-3.0	301.9	1.000	11.79	0.990
4	20.096	20.234	20.4	-3.5	20.4	-3.5	302.5	1.000	11.84	0.991
5	19.855	20.005	20.7	-3.3	20.7	-3.3	302.9	1.000	11.87	0.991
6	19.614	19.779	21.9	-2.9	21.9	-2.9	303.3	1.000	11.86	0.991
7	19.373	19.550	23.5	-2.4	23.5	-2.4	303.9	0.999	11.81	0.995
8	19.131	19.324	24.9	-2.0	24.9	-2.0	304.9	0.997	11.85	0.997
9	17.676	17.973	24.5	-2.9	24.5	-2.9	304.4	1.000	12.12	0.991
10	15.735	16.215	28.5	-1.4	28.5	-1.4	306.8	1.000	12.40	0.992
11	15.253	15.786	29.8	0.5	29.8	0.5	307.5	0.999	12.56	0.965

RP	ABS VEL		REL VEL		MERID VEL		TANG VEL		WHEEL SPEED	
	IN	OUT	IN	OUT	IN	OUT	IN	OUT	IN	OUT
1	185.3	161.9	185.3	161.9	176.1	161.9	57.4	1.4	0.	0.
2	184.8	173.2	184.8	173.2	176.0	173.2	56.4	-1.7	0.	0.
3	179.7	174.3	179.7	174.3	170.2	174.1	57.7	-9.1	0.	0.
4	181.6	178.7	181.6	178.7	170.2	178.4	63.3	-10.9	0.	0.
5	182.9	179.8	182.9	179.8	171.1	179.5	64.6	-10.2	0.	0.
6	182.6	180.1	182.6	180.1	169.4	179.8	68.2	-9.2	0.	0.
7	181.0	180.2	181.0	180.2	166.0	180.1	72.1	-7.7	0.	0.
8	182.8	183.5	182.8	183.5	165.9	183.4	76.9	-6.3	0.	0.
9	195.8	194.2	195.8	194.2	178.2	194.0	81.1	-9.9	0.	0.
10	213.0	216.4	213.0	216.4	187.2	216.3	101.7	-5.3	0.	0.
11	219.3	214.7	219.3	214.7	190.2	214.7	109.2	2.0	0.	0.

RP	ABS MACH NO		REL MACH NO		MERID MACH NO		MERID PEAK SS	
	IN	OUT	IN	OUT	IN	OUT	VEL R	MACH NO
1	0.545	0.473	0.545	0.473	0.518	0.473	0.919	0.545
2	0.545	0.509	0.545	0.509	0.519	0.509	0.984	0.545
3	0.530	0.513	0.530	0.513	0.502	0.513	1.023	0.530
4	0.536	0.527	0.536	0.527	0.502	0.526	1.048	0.536
5	0.539	0.530	0.539	0.530	0.505	0.529	1.049	0.539
6	0.538	0.530	0.538	0.530	0.499	0.529	1.062	0.538
7	0.532	0.530	0.532	0.530	0.488	0.530	1.085	0.532
8	0.537	0.540	0.537	0.540	0.487	0.540	1.106	0.537
9	0.578	0.573	0.578	0.573	0.526	0.572	1.088	0.578
10	0.630	0.641	0.630	0.641	0.554	0.641	1.156	0.630
11	0.650	0.635	0.650	0.635	0.564	0.635	1.128	0.650

RP	PERCENT		INCIDENCE		DEV	D-FACT	EFF	LOSS COEFF		LOSS PARAM	
	SPAN	MEAN	SS	TOT				PROF	TOT	PROF	
1	5.00	-9.7	-16.1	9.0	0.243	0.	0.175	0.175	0.068	0.068	
2	10.00	-9.4	-15.8	7.5	0.182	0.	0.052	0.052	0.020	0.020	
3	30.00	-8.5	-14.9	4.5	0.159	0.	0.056	0.056	0.020	0.020	
4	45.00	-7.7	-14.1	3.9	0.148	0.	0.048	0.048	0.016	0.016	
5	47.50	-7.6	-14.0	4.1	0.148	0.	0.052	0.052	0.017	0.017	
6	50.00	-6.6	-13.0	4.4	0.148	0.	0.048	0.048	0.015	0.015	
7	52.50	-5.3	-11.7	4.9	0.142	0.	0.028	0.028	0.009	0.009	
8	55.00	-4.1	-10.5	5.4	0.137	0.	0.019	0.019	0.006	0.006	
9	70.00	-6.0	-12.4	4.5	0.141	0.	0.046	0.046	0.013	0.013	
10	90.00	-5.0	-11.3	6.2	0.111	0.	0.035	0.035	0.009	0.009	
11	95.00	-4.8	-11.1	8.2	0.140	0.	0.143	0.143	0.036	0.036	

TABLE VIII. - Continued. BLADE-ELEMENT DATA AT BLADE

EDGES FOR STATOR 12

(p) 70 Percent of design speed; reading number 1174

RP	RADII		ABS BETAM		REL BETAM		TOTAL TEMP		TOTAL PRESS	
	IN	OUT	IN	OUT	IN	OUT	IN	RATIO	IN	RATIO
1	23.904	23.884	25.6	1.6	25.6	1.6	309.9	1.001	12.40	0.977
2	23.437	23.426	24.7	0.6	24.7	0.6	308.4	1.001	12.40	0.993
3	21.542	21.603	25.3	-2.4	25.3	-2.4	306.4	1.000	12.32	0.994
4	20.096	20.234	27.4	-2.6	27.4	-2.6	306.3	1.000	12.25	0.995
5	19.855	20.005	27.9	-2.5	27.9	-2.5	306.2	1.000	12.26	0.993
6	19.614	19.779	29.0	-2.0	29.0	-2.0	307.4	0.998	12.33	0.988
7	19.373	19.550	31.0	-1.7	31.0	-1.7	307.3	0.998	12.20	0.996
8	19.131	19.324	32.6	-1.3	32.6	-1.3	308.1	0.997	12.17	0.998
9	17.676	17.973	31.6	-2.2	31.6	-2.2	307.3	0.998	12.33	0.992
10	15.735	16.215	33.6	-0.6	33.6	-0.6	308.6	1.000	12.72	0.989
11	15.253	15.786	34.4	1.1	34.4	1.1	308.7	1.000	12.73	0.965

RP	ABS VEL		REL VEL		MERID VEL		TANG VEL		WHEEL SPEED	
	IN	OUT	IN	OUT	IN	OUT	IN	OUT	IN	OUT
1	179.2	149.7	179.2	149.7	161.6	149.6	77.4	4.2	0.	0.
2	177.8	158.0	177.8	158.0	161.6	157.9	74.3	1.6	0.	0.
3	171.7	155.2	171.7	155.2	155.2	155.1	73.5	-6.4	0.	0.
4	169.9	154.2	169.9	154.2	150.9	154.1	78.1	-6.9	0.	0.
5	170.8	154.2	170.8	154.2	151.0	154.1	79.8	-6.6	0.	0.
6	174.4	155.0	174.4	155.0	152.5	154.9	84.6	-5.3	0.	0.
7	169.3	154.6	169.3	154.6	145.1	154.5	87.2	-4.5	0.	0.
8	168.2	154.3	168.2	154.3	141.8	154.2	90.6	-3.6	0.	0.
9	179.3	160.9	179.3	160.9	152.7	160.7	94.0	-6.2	0.	0.
10	201.5	183.6	201.5	183.6	167.7	183.6	111.6	-2.0	0.	0.
11	203.7	175.0	203.7	175.0	168.1	175.0	115.0	3.4	0.	0.

RP	ABS MACH NO		REL MACH NO		MERID MACH NO		MERID PEAK SS	
	IN	OUT	IN	OUT	IN	OUT	VEL R	MACH NO
1	0.521	0.432	0.521	0.432	0.470	0.432	0.926	0.521
2	0.519	0.458	0.519	0.458	0.471	0.458	0.978	0.519
3	0.502	0.451	0.502	0.451	0.453	0.451	0.999	0.502
4	0.496	0.448	0.496	0.448	0.441	0.448	1.021	0.502
5	0.499	0.448	0.499	0.448	0.441	0.448	1.020	0.518
6	0.509	0.450	0.509	0.450	0.445	0.450	1.015	0.558
7	0.493	0.449	0.493	0.449	0.423	0.449	1.065	0.582
8	0.489	0.448	0.489	0.448	0.412	0.448	1.088	0.604
9	0.524	0.468	0.524	0.468	0.446	0.468	1.053	0.594
10	0.592	0.536	0.592	0.536	0.493	0.536	1.095	0.652
11	0.599	0.510	0.599	0.510	0.494	0.510	1.041	0.654

RP	PERCENT	INCIDENCE		DEV	D-FACT	EFF	LOSS COEFF		LOSS PARAM	
	SPAN	MEAN	SS				TOT	PROF	TOT	PROF
1	5.00	-2.1	-8.5	10.1	0.322	0.	0.134	0.134	0.052	0.052
2	10.00	-2.4	-8.9	8.7	0.267	0.	0.043	0.043	0.016	0.016
3	30.00	-1.8	-8.3	5.2	0.258	0.	0.041	0.041	0.014	0.014
4	45.00	-0.7	-7.1	4.8	0.255	0.	0.034	0.034	0.011	0.011
5	47.50	-0.5	-6.9	4.9	0.259	0.	0.046	0.046	0.015	0.015
6	50.00	0.5	-5.9	5.4	0.275	0.	0.073	0.073	0.023	0.023
7	52.50	2.2	-4.2	5.7	0.256	0.	0.025	0.025	0.008	0.008
8	55.00	3.6	-2.8	6.0	0.256	0.	0.013	0.013	0.004	0.004
9	70.00	1.1	-5.2	5.1	0.262	0.	0.049	0.049	0.014	0.014
10	90.00	0.2	-6.2	6.9	0.231	0.	0.054	0.054	0.014	0.014
11	95.00	-0.2	-6.5	8.8	0.274	0.	0.161	0.161	0.040	0.040

TABLE VIII. - Continued. BLADE-ELEMENT DATA AT BLADE

EDGES FOR STATOR 12

(q) 70 Percent of design speed; reading number 1175

RP	RADII		ABS BETAM		REL BETAM		TOTAL TEMP		TOTAL PRESS	
	IN	OUT	IN	OUT	IN	OUT	IN	RATIO	IN	RATIO
1	23.904	23.884	35.4	2.9	35.4	2.9	316.5	0.998	12.85	0.981
2	23.437	23.426	34.3	2.5	34.3	2.5	314.3	1.000	12.86	0.990
3	21.542	21.603	36.1	-0.6	36.1	-0.6	311.8	0.999	12.64	0.993
4	20.096	20.234	38.0	0.5	38.0	0.5	311.7	0.998	12.66	0.984
5	19.855	20.005	38.6	0.3	38.6	0.3	311.4	0.999	12.65	0.984
6	19.614	19.779	40.5	0.2	40.5	0.2	311.8	0.998	12.60	0.986
7	19.373	19.550	42.3	0.1	42.3	0.1	311.9	0.997	12.50	0.992
8	19.131	19.324	44.2	0.1	44.2	0.1	312.0	0.997	12.48	0.993
9	17.676	17.973	40.7	-0.2	40.7	-0.2	311.0	0.999	12.65	0.987
10	15.735	16.215	37.8	-0.2	37.8	-0.2	310.0	1.000	12.95	0.979
11	15.253	15.786	38.5	2.4	38.5	2.4	309.9	1.001	12.87	0.966

RP	ABS VEL		REL VEL		MERID VEL		TANG VEL		WHEEL SPEED	
	IN	OUT	IN	OUT	IN	OUT	IN	OUT	IN	OUT
1	169.9	133.4	169.9	133.4	138.5	133.2	98.5	6.7	0.	0.
2	170.2	139.3	170.2	139.3	140.6	139.2	96.0	6.2	0.	0.
3	160.3	131.1	160.3	131.1	129.5	131.1	94.4	-1.3	0.	0.
4	163.9	127.9	163.9	127.9	129.1	127.9	101.0	1.1	0.	0.
5	163.9	127.3	163.9	127.3	128.1	127.3	102.3	0.6	0.	0.
6	162.4	126.6	162.4	126.6	123.6	126.6	105.4	0.5	0.	0.
7	158.8	125.8	158.8	125.8	117.4	125.8	106.9	0.3	0.	0.
8	158.5	125.2	158.5	125.2	113.7	125.2	110.5	0.3	0.	0.
9	170.9	132.9	170.9	132.9	129.5	132.9	111.5	-0.4	0.	0.
10	190.2	149.5	190.2	149.5	150.2	149.5	116.7	-0.4	0.	0.
11	190.3	139.1	190.3	139.1	148.9	138.9	118.5	5.8	0.	0.

RP	ABS MACH NO		REL MACH NO		MERID MACH NO		MERID PEAK SS	
	IN	OUT	IN	OUT	IN	OUT	VEL R	MACH NO
1	0.488	0.380	0.488	0.380	0.397	0.379	0.962	0.692
2	0.490	0.398	0.490	0.398	0.405	0.398	0.990	0.680
3	0.462	0.376	0.462	0.376	0.374	0.376	1.012	0.660
4	0.473	0.366	0.473	0.366	0.373	0.366	0.990	0.691
5	0.474	0.365	0.474	0.365	0.370	0.365	0.994	0.697
6	0.469	0.363	0.469	0.363	0.357	0.363	1.024	0.716
7	0.458	0.360	0.458	0.360	0.339	0.360	1.071	0.725
8	0.457	0.359	0.457	0.359	0.328	0.359	1.101	0.749
9	0.495	0.381	0.495	0.381	0.375	0.381	1.026	0.729
10	0.555	0.431	0.555	0.431	0.439	0.431	0.995	0.710
11	0.556	0.400	0.556	0.400	0.435	0.400	0.933	0.705

RP	PERCENT		INCIDENCE		DEV	D-FACT	EFF	LOSS COEFF		LOSS PARAM	
	SPAN	MEAN	SS	TOT				PROF	TOT	PROF	
1	5.00	7.7	1.3	11.4	0.424	0.	0.126	0.126	0.048	0.048	
2	10.00	7.2	0.8	10.6	0.381	0.	0.065	0.065	0.025	0.025	
3	30.00	8.9	2.5	6.9	0.390	0.	0.053	0.053	0.018	0.018	
4	45.00	9.9	3.5	7.9	0.418	0.	0.113	0.113	0.037	0.037	
5	47.50	10.3	3.9	7.7	0.422	0.	0.113	0.113	0.036	0.036	
6	50.00	11.9	5.5	7.6	0.425	0.	0.100	0.100	0.032	0.032	
7	52.50	13.6	7.1	7.5	0.417	0.	0.059	0.059	0.019	0.019	
8	55.00	15.2	8.8	7.5	0.425	0.	0.053	0.053	0.017	0.017	
9	70.00	10.2	3.9	7.2	0.409	0.	0.081	0.081	0.023	0.023	
10	90.00	4.4	-2.0	7.4	0.369	0.	0.112	0.112	0.029	0.029	
11	95.00	3.9	-2.4	10.1	0.414	0.	0.178	0.178	0.044	0.044	

TABLE VIII. - Continued. BLADE-ELEMENT DATA AT BLADE

EDGES FOR STATOR 12

(r) 70 Percent of design speed; reading number 1176

RP	RADII		ABS BETAM		REL BETAM		TOTAL TEMP		TOTAL PRESS	
	IN	OUT	IN	OUT	IN	OUT	IN	RATIO	IN	RATIO
1	23.904	23.884	56.5	4.8	56.5	4.8	326.5	0.986	13.11	0.959
2	23.437	23.426	48.9	4.6	48.9	4.6	323.0	0.992	13.00	0.970
3	21.542	21.603	41.9	1.9	41.9	1.9	314.8	1.001	12.78	0.988
4	20.096	20.234	43.6	1.5	43.6	1.5	314.0	0.998	12.80	0.980
5	19.855	20.005	44.2	1.1	44.2	1.1	313.9	0.998	12.79	0.978
6	19.614	19.779	45.9	0.9	45.9	0.9	313.9	0.998	12.73	0.982
7	19.373	19.550	48.5	0.7	48.5	0.7	313.9	0.998	12.64	0.988
8	19.131	19.324	50.5	0.6	50.5	0.6	314.3	0.997	12.58	0.991
9	17.676	17.973	45.9	1.2	45.9	1.2	312.6	0.999	12.71	0.989
10	15.735	16.215	39.4	0.7	39.4	0.7	310.2	1.000	12.97	0.974
11	15.253	15.786	39.9	4.2	39.9	4.2	309.7	1.001	12.88	0.965

RP	ABS VEL		REL VEL		MERID VEL		TANG VEL		WHEEL SPEED	
	IN	OUT	IN	OUT	IN	OUT	IN	OUT	IN	OUT
1	168.8	118.4	168.8	118.4	93.1	118.0	140.9	9.9	0.	0.
2	164.9	120.5	164.9	120.5	108.3	120.1	124.3	9.8	0.	0.
3	157.7	122.5	157.7	122.5	117.5	122.5	105.3	4.1	0.	0.
4	161.2	118.0	161.2	118.0	116.8	118.0	111.1	3.0	0.	0.
5	161.5	116.8	161.5	116.8	115.7	116.8	112.6	2.3	0.	0.
6	159.3	116.0	159.3	116.0	110.7	116.0	114.5	1.9	0.	0.
7	155.8	115.3	155.8	115.3	103.2	115.3	116.7	1.5	0.	0.
8	154.5	115.2	154.5	115.2	98.3	115.2	119.2	1.3	0.	0.
9	166.3	123.7	166.3	123.7	115.6	123.7	119.5	2.5	0.	0.
10	183.7	133.6	183.7	133.6	141.9	133.6	116.6	1.7	0.	0.
11	184.0	124.0	184.0	124.0	141.2	123.6	118.0	9.2	0.	0.

RP	ABS MACH NO		REL MACH NO		MERID MACH NO		MERID PEAK SS	
	IN	OUT	IN	OUT	IN	OUT	VEL R	MACH NO
1	0.477	0.333	0.477	0.333	0.263	0.332	1.268	1.028
2	0.468	0.340	0.468	0.340	0.307	0.339	1.109	0.882
3	0.452	0.349	0.452	0.349	0.337	0.348	1.043	0.735
4	0.463	0.336	0.463	0.336	0.336	0.336	1.010	0.763
5	0.464	0.333	0.464	0.333	0.333	0.333	1.010	0.772
6	0.458	0.330	0.458	0.330	0.318	0.330	1.047	0.784
7	0.447	0.329	0.447	0.329	0.296	0.329	1.118	0.803
8	0.443	0.328	0.443	0.328	0.282	0.328	1.171	0.823
9	0.480	0.354	0.480	0.354	0.334	0.354	1.070	0.792
10	0.535	0.384	0.535	0.384	0.413	0.384	0.941	0.714
11	0.537	0.356	0.537	0.356	0.412	0.355	0.875	0.708

RP	PERCENT SPAN	INCIDENCE		DEV	D-FACT	EFF	LOSS COEFF		LOSS PARAM	
		MEAN	SS				TOT	PROF	TOT	PROF
1	5.00	28.8	22.4	13.3	0.598	0.	0.283	0.283	0.109	0.109
2	10.00	21.8	15.4	12.8	0.532	0.	0.216	0.216	0.082	0.082
3	30.00	14.7	8.3	9.4	0.446	0.	0.088	0.088	0.031	0.031
4	45.00	15.4	9.0	8.9	0.485	0.	0.146	0.146	0.047	0.047
5	47.50	15.9	9.5	8.5	0.495	0.	0.157	0.157	0.051	0.051
6	50.00	17.4	11.0	8.3	0.495	0.	0.137	0.137	0.044	0.044
7	52.50	19.8	13.4	8.1	0.491	0.	0.097	0.097	0.030	0.030
8	55.00	21.5	15.1	8.0	0.490	0.	0.074	0.074	0.023	0.023
9	70.00	15.5	9.1	8.5	0.456	0.	0.074	0.074	0.021	0.021
10	90.00	5.9	-0.4	8.3	0.430	0.	0.148	0.148	0.038	0.038
11	95.00	5.3	-1.0	11.9	0.470	0.	0.198	0.198	0.049	0.049

TABLE VIII. - Continued. BLADE-ELEMENT DATA AT BLADE

EDGES FOR STATOR 12

(s) 60 Percent of design speed; reading number 1177

RP	RADII		ABS BETAM		REL BETAM		TOTAL TEMP		TOTAL PRESS	
	IN	OUT	IN	OUT	IN	OUT	IN	RATIO	IN	RATIO
1	23.904	23.884	57.8	5.3	57.8	5.3	316.3	0.989	12.29	0.968
2	23.437	23.426	50.0	5.1	50.0	5.1	313.5	0.994	12.19	0.978
3	21.542	21.603	41.3	2.2	41.3	2.2	307.4	1.001	12.05	0.990
4	20.096	20.234	42.9	2.0	42.9	2.0	307.0	0.999	12.05	0.985
5	19.855	20.005	43.6	1.6	43.6	1.6	306.9	0.998	12.05	0.983
6	19.614	19.779	45.3	1.3	45.3	1.3	306.8	0.998	12.00	0.987
7	19.373	19.550	47.7	0.9	47.7	0.9	306.9	0.998	11.95	0.989
8	19.131	19.324	49.9	0.7	49.9	0.7	306.9	0.998	11.91	0.992
9	17.676	17.973	46.2	1.3	46.2	1.3	306.4	0.998	11.98	0.991
10	15.735	16.215	39.4	0.9	39.4	0.9	304.4	1.001	12.18	0.981
11	15.253	15.786	39.9	4.1	39.9	4.1	304.3	1.001	12.13	0.972

RP	ABS VEL		REL VEL		MERID VEL		TANG VEL		WHEEL SPEED	
	IN	OUT	IN	OUT	IN	OUT	IN	OUT	IN	OUT
1	144.3	101.4	144.3	101.4	76.8	101.0	122.2	9.4	0.	0.
2	140.0	103.7	140.0	103.7	90.0	103.3	107.3	9.3	0.	0.
3	135.2	104.6	135.2	104.6	101.7	104.6	89.2	4.0	0.	0.
4	137.8	101.5	137.8	101.5	100.9	101.5	93.9	3.6	0.	0.
5	138.1	100.3	138.1	100.3	100.0	100.2	95.3	2.9	0.	0.
6	135.9	100.0	135.9	100.0	95.6	100.0	96.7	2.2	0.	0.
7	133.6	98.7	133.6	98.7	90.0	98.6	98.8	1.5	0.	0.
8	132.1	98.3	132.1	98.3	85.1	98.3	101.0	1.1	0.	0.
9	141.1	104.8	141.1	104.8	97.7	104.8	101.9	2.4	0.	0.
10	157.1	114.9	157.1	114.9	121.4	114.9	99.7	1.9	0.	0.
11	158.0	105.7	158.0	105.7	121.2	105.4	101.2	7.6	0.	0.

RP	ABS MACH NO		REL MACH NO		MERID MACH NO		MERID PEAK SS	
	IN	OUT	IN	OUT	IN	OUT	VEL R	MACH NO
1	0.412	0.288	0.412	0.288	0.219	0.287	1.314	0.909
2	0.401	0.296	0.401	0.296	0.258	0.294	1.147	0.771
3	0.391	0.300	0.391	0.300	0.294	0.300	1.029	0.626
4	0.399	0.292	0.399	0.292	0.292	0.292	1.006	0.648
5	0.399	0.288	0.399	0.288	0.289	0.288	1.003	0.656
6	0.393	0.287	0.393	0.287	0.276	0.287	1.046	0.666
7	0.386	0.283	0.386	0.283	0.260	0.283	1.096	0.682
8	0.382	0.282	0.382	0.282	0.246	0.282	1.154	0.700
9	0.409	0.302	0.409	0.302	0.283	0.302	1.073	0.678
10	0.459	0.332	0.459	0.332	0.354	0.332	0.946	0.612
11	0.461	0.305	0.461	0.305	0.354	0.304	0.869	0.608

RP	PERCENT	INCIDENCE		DEV	D-FACT	EFF	LOSS COEFF		LOSS PARAM	
	SPAN	MEAN	SS				TOT	PROF	TOT	PROF
1	5.00	30.1	23.7	13.8	0.599	0.	0.289	0.289	0.111	0.111
2	10.00	22.9	16.4	13.3	0.524	0.	0.211	0.211	0.080	0.080
3	30.00	14.1	7.7	9.7	0.445	0.	0.102	0.102	0.036	0.036
4	45.00	14.8	8.4	9.4	0.476	0.	0.147	0.147	0.048	0.048
5	47.50	15.3	8.9	9.0	0.488	0.	0.159	0.159	0.051	0.051
6	50.00	16.8	10.4	8.6	0.484	0.	0.131	0.131	0.041	0.041
7	52.50	18.9	12.5	8.3	0.489	0.	0.110	0.110	0.035	0.035
8	55.00	20.9	14.5	8.0	0.489	0.	0.079	0.079	0.025	0.025
9	70.00	15.7	9.3	8.7	0.458	0.	0.079	0.079	0.023	0.023
10	90.00	5.9	-0.4	8.5	0.426	0.	0.140	0.140	0.036	0.036
11	95.00	5.3	-1.0	11.8	0.475	0.	0.205	0.205	0.051	0.051

TABLE VIII. - Concluded. BLADE-ELEMENT DATA AT BLADE

EDGES FOR STATOR 12

(t) 50 Percent of design speed; reading number 1178

RP	RADII		ABS BETAM		REL BETAM		TOTAL TEMP		TOTAL PRESS	
	IN	OUT	IN	OUT	IN	OUT	IN	RATIO	IN	RATIO
1	23.904	23.884	56.5	5.8	56.5	5.8	308.0	0.992	11.63	0.978
2	23.437	23.426	49.0	5.2	49.0	5.2	306.0	0.996	11.57	0.985
3	21.542	21.603	41.4	1.9	41.4	1.9	301.7	1.000	11.47	0.993
4	20.096	20.234	43.0	1.9	43.0	1.9	301.4	0.999	11.48	0.988
5	19.855	20.005	43.7	1.6	43.7	1.6	301.4	0.999	11.47	0.988
6	19.614	19.779	45.7	1.1	45.7	1.1	301.3	0.999	11.44	0.990
7	19.373	19.550	48.3	0.9	48.3	0.9	301.4	0.998	11.40	0.993
8	19.131	19.324	50.3	0.5	50.3	0.5	301.3	0.999	11.38	0.994
9	17.676	17.973	46.0	1.3	46.0	1.3	300.9	0.999	11.43	0.993
10	15.735	16.215	39.5	0.9	39.5	0.9	299.5	1.001	11.55	0.987
11	15.253	15.786	40.2	5.0	40.2	5.0	299.4	1.001	11.51	0.981

RP	ABS VEL		REL VEL		MERID VEL		TANG VEL		WHEEL SPEED	
	IN	OUT	IN	OUT	IN	OUT	IN	OUT	IN	OUT
1	120.6	85.6	120.6	85.6	66.5	85.2	100.6	8.6	0.	0.
2	117.5	87.7	117.5	87.7	77.1	87.4	88.7	7.9	0.	0.
3	113.4	88.5	113.4	88.5	85.0	88.4	75.1	3.0	0.	0.
4	116.1	85.3	116.1	85.3	84.9	85.3	79.3	2.8	0.	0.
5	115.6	84.4	115.6	84.4	83.6	84.3	79.9	2.3	0.	0.
6	114.3	83.7	114.3	83.7	79.8	83.7	81.9	1.6	0.	0.
7	111.8	83.0	111.8	83.0	74.3	83.0	83.5	1.4	0.	0.
8	111.0	82.7	111.0	82.7	71.0	82.7	85.4	0.8	0.	0.
9	119.4	88.4	119.4	88.4	82.9	88.4	85.9	2.0	0.	0.
10	131.4	97.1	131.4	97.1	101.4	97.1	83.5	1.5	0.	0.
11	131.7	89.2	131.7	89.2	100.6	88.8	85.0	7.7	0.	0.

RP	ABS MACH NO		REL MACH NO		MERID MACH NO		MERID PEAK SS	
	IN	OUT	IN	OUT	IN	OUT	VEL R	MACH NO
1	0.347	0.246	0.347	0.246	0.191	0.244	1.280	0.749
2	0.339	0.252	0.339	0.252	0.222	0.251	1.134	0.640
3	0.329	0.256	0.329	0.256	0.247	0.256	1.040	0.530
4	0.338	0.247	0.338	0.247	0.247	0.247	1.004	0.550
5	0.336	0.244	0.336	0.244	0.243	0.244	1.009	0.553
6	0.332	0.242	0.332	0.242	0.232	0.242	1.048	0.567
7	0.324	0.240	0.324	0.240	0.216	0.240	1.118	0.580
8	0.322	0.239	0.322	0.239	0.206	0.239	1.166	0.596
9	0.347	0.256	0.347	0.256	0.241	0.256	1.066	0.574
10	0.384	0.282	0.384	0.282	0.297	0.282	0.957	0.514
11	0.385	0.259	0.385	0.259	0.294	0.258	0.883	0.512

RP	PERCENT	INCIDENCE		DEV	D-FACT	EFF	LOSS COEFF		LOSS PARAM	
	SPAN	MEAN	SS				TOT	PROF	TOT	PROF
1	5.00	28.8	22.4	14.3	0.585	0.	0.280	0.280	0.107	0.107
2	10.00	21.9	15.5	13.3	0.514	0.	0.202	0.202	0.076	0.076
3	30.00	14.3	7.9	9.4	0.441	0.	0.091	0.091	0.032	0.032
4	45.00	14.9	8.5	9.3	0.479	0.	0.154	0.154	0.050	0.050
5	47.50	15.4	9.0	9.0	0.485	0.	0.155	0.155	0.050	0.050
6	50.00	17.2	10.8	8.5	0.490	0.	0.141	0.141	0.045	0.045
7	52.50	19.6	13.2	8.3	0.486	0.	0.102	0.102	0.032	0.032
8	55.00	21.3	14.9	7.9	0.490	0.	0.083	0.083	0.026	0.026
9	70.00	15.6	9.2	8.7	0.459	0.	0.087	0.087	0.025	0.025
10	90.00	6.0	-0.3	8.5	0.419	0.	0.132	0.132	0.034	0.034
11	95.00	5.6	-0.7	12.6	0.466	0.	0.194	0.194	0.048	0.048

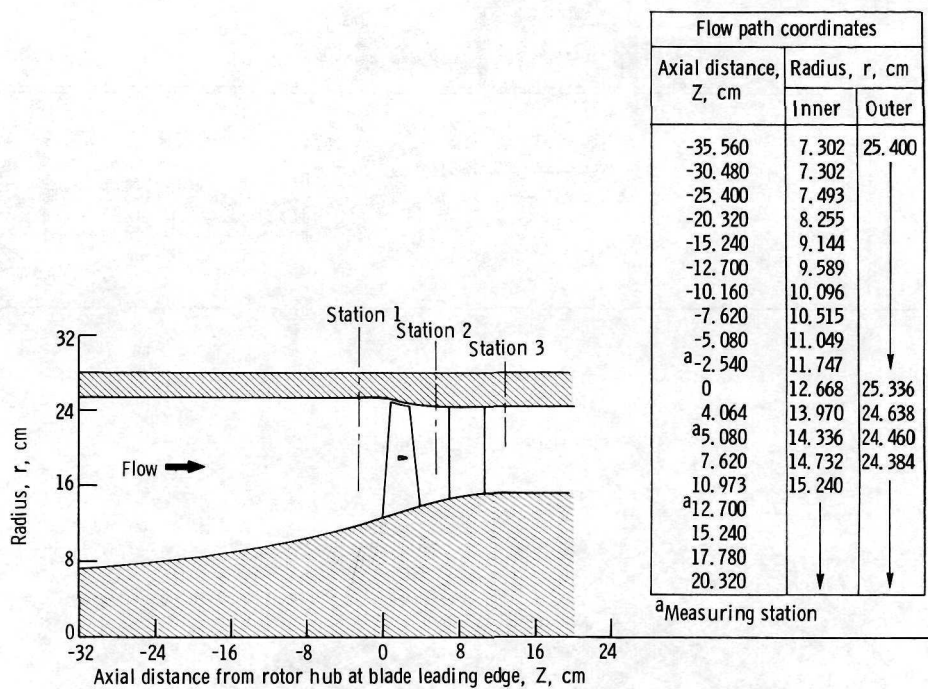
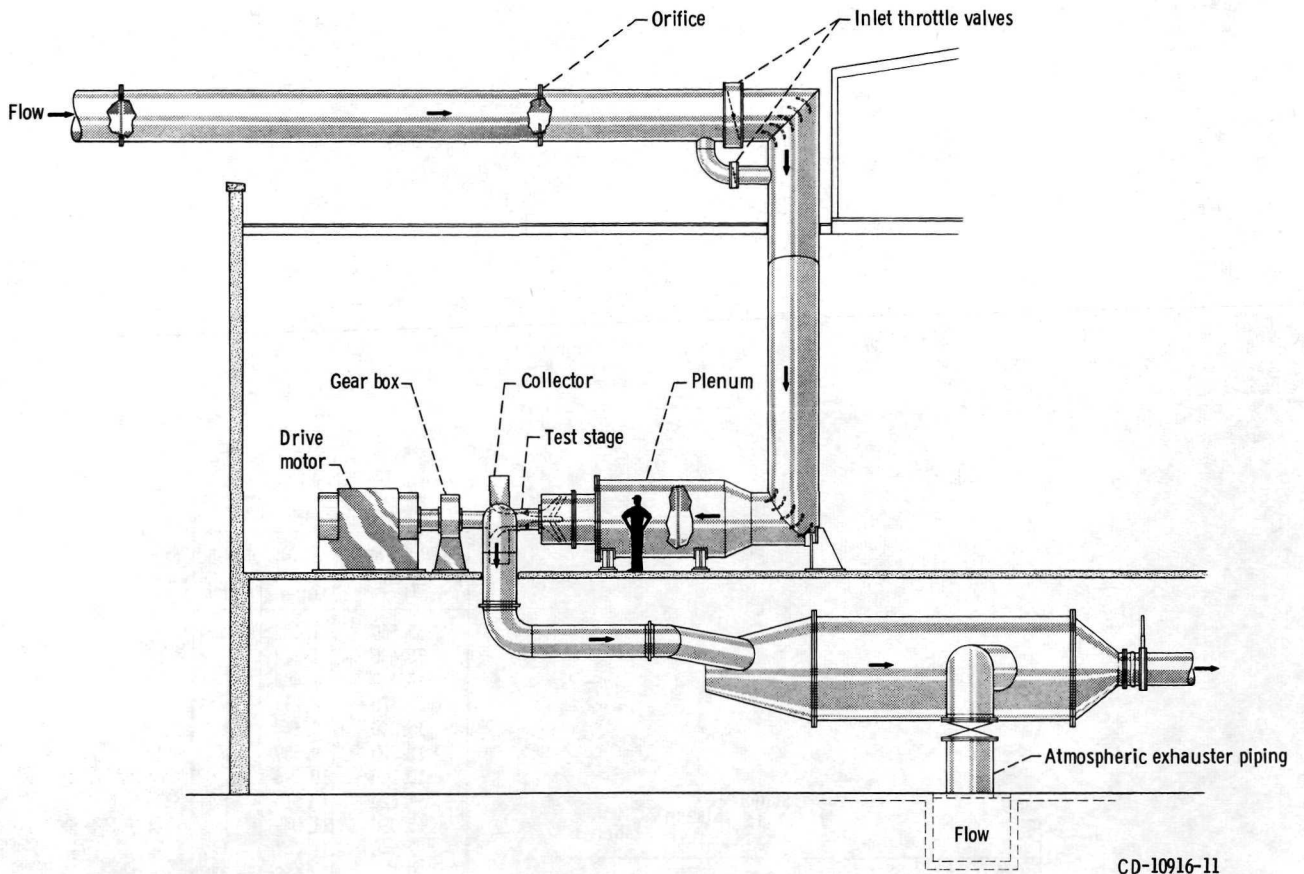
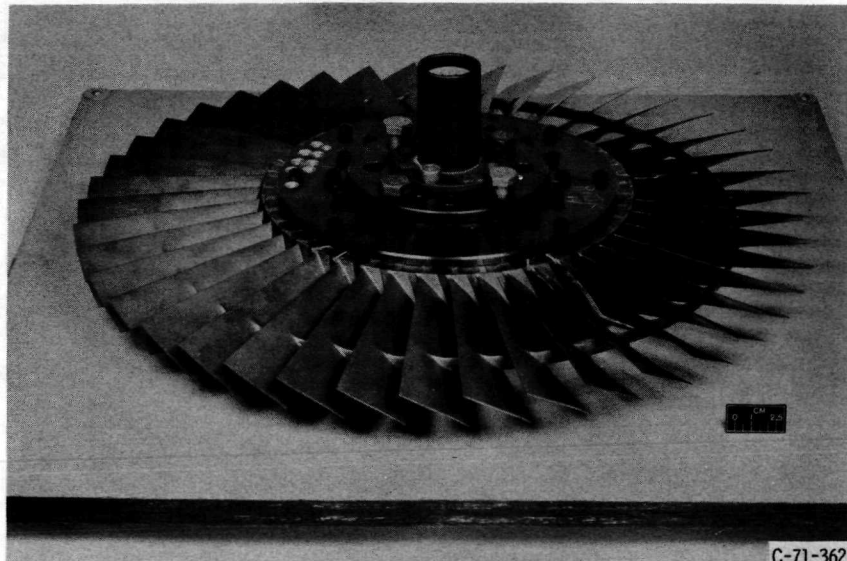

Figure 1. - Flow path for stage showing axial location of instrumentation.



CD-10916-11

Figure 2. - Test facility.



C-71-362

Figure 3. - Test rotor (rotor 14).

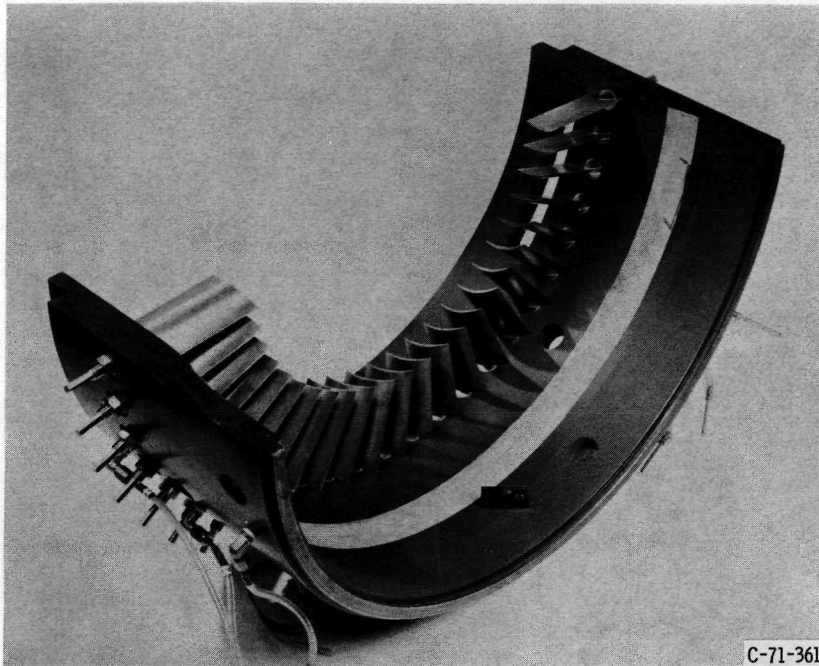
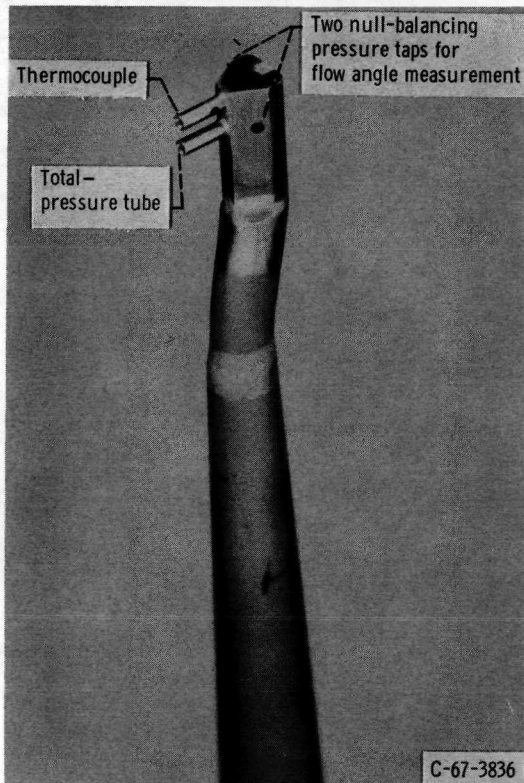
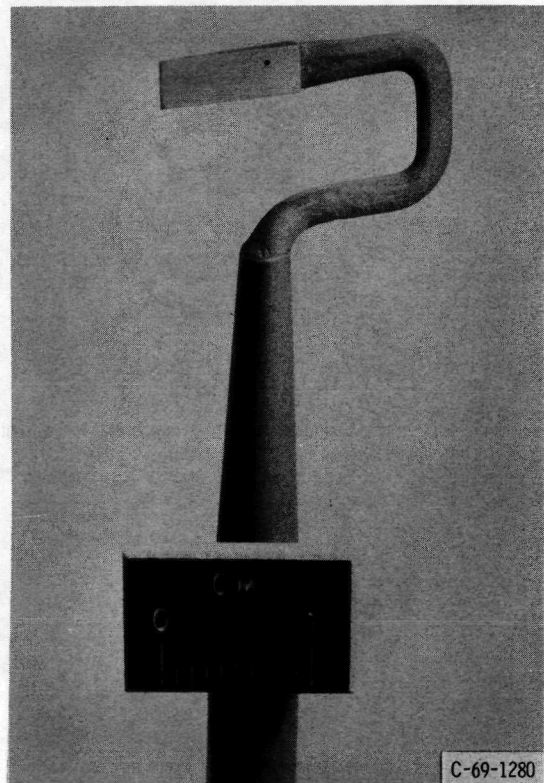

Figure 4. - Test stator (stator 10).



(a) Combination total pressure, total temperature, and flow angle probe (double barrel).



(b) Static-pressure probe.

Figure 5. - Survey probes.

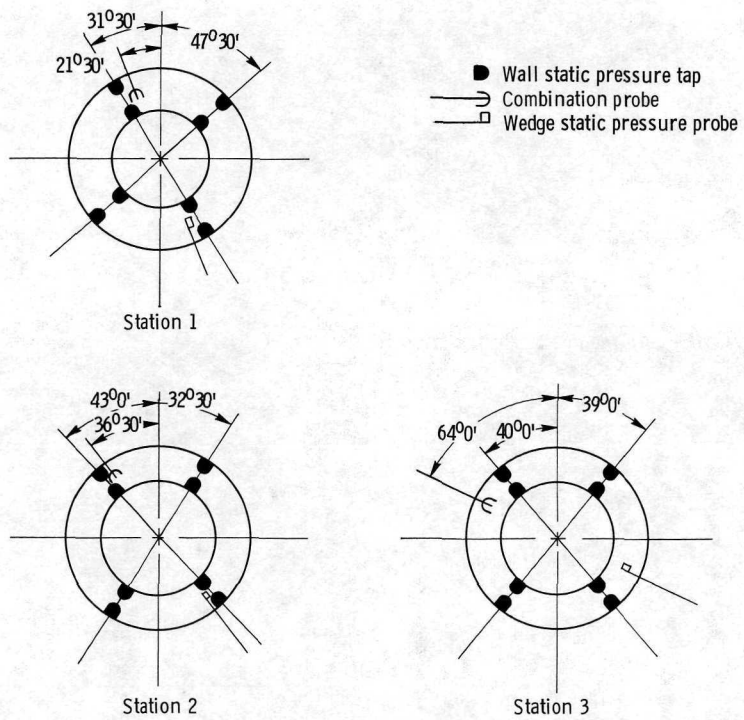

Figure 6. - Circumferential location of measurements (looking downstream; clockwise rotation).

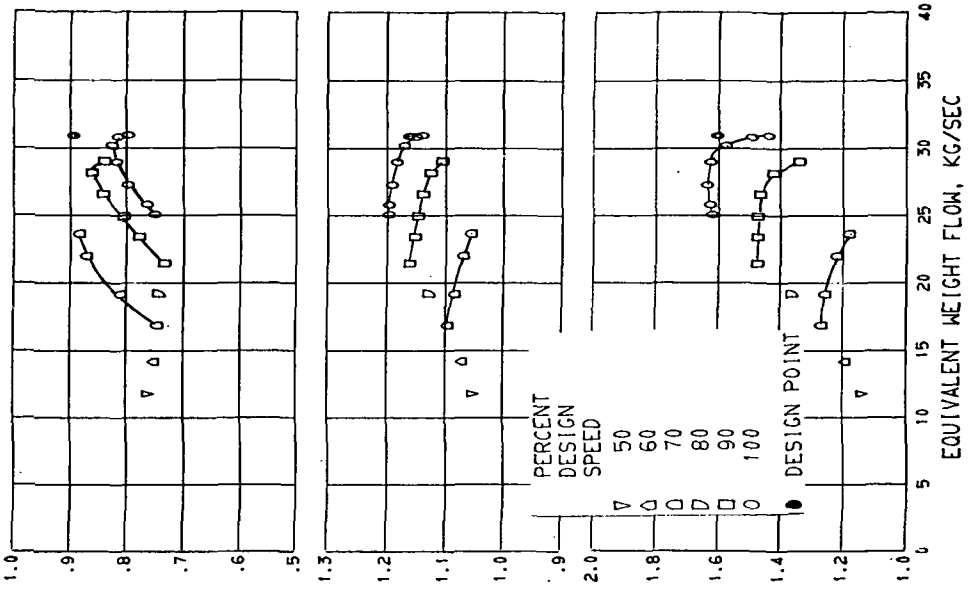

FIGURE 7. - OVERALL PERFORMANCE FOR STAGE 17-12.

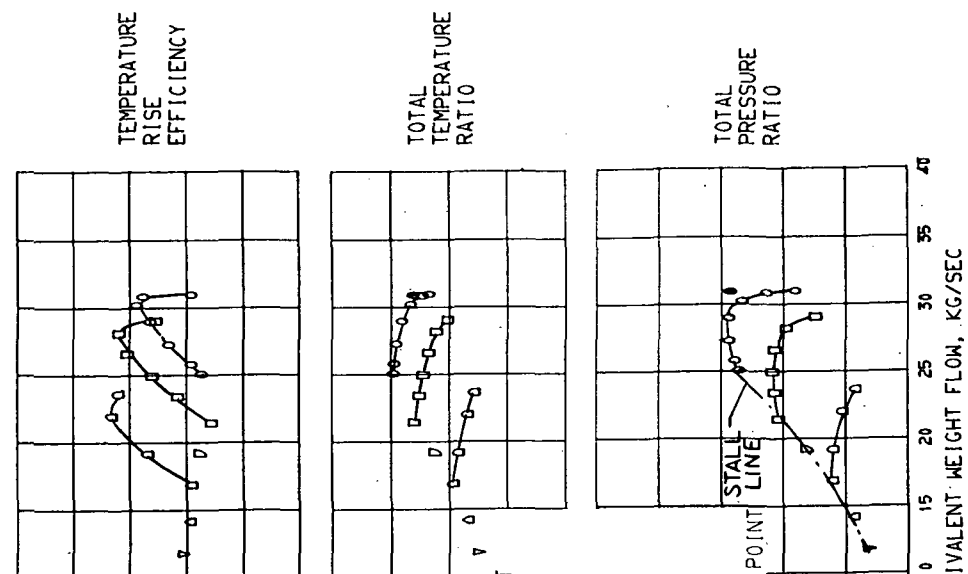
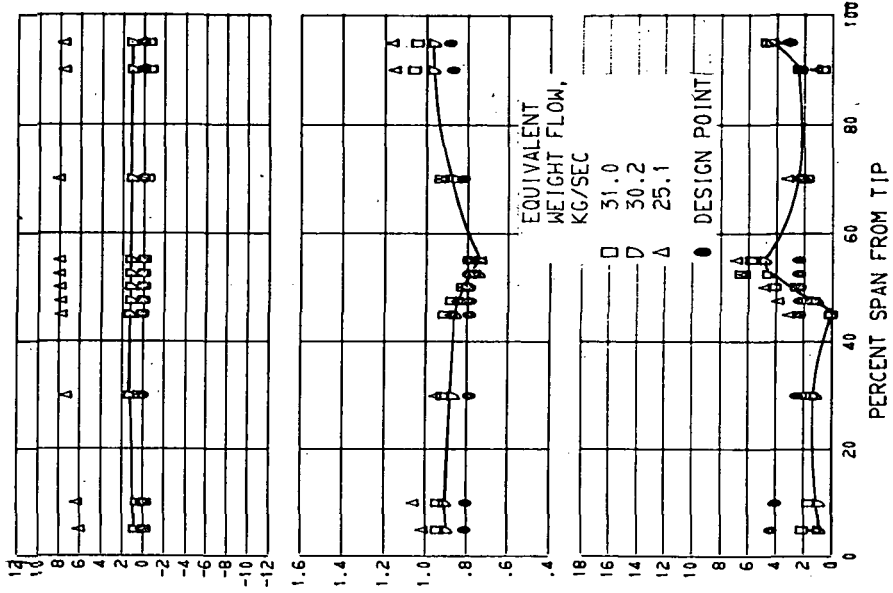
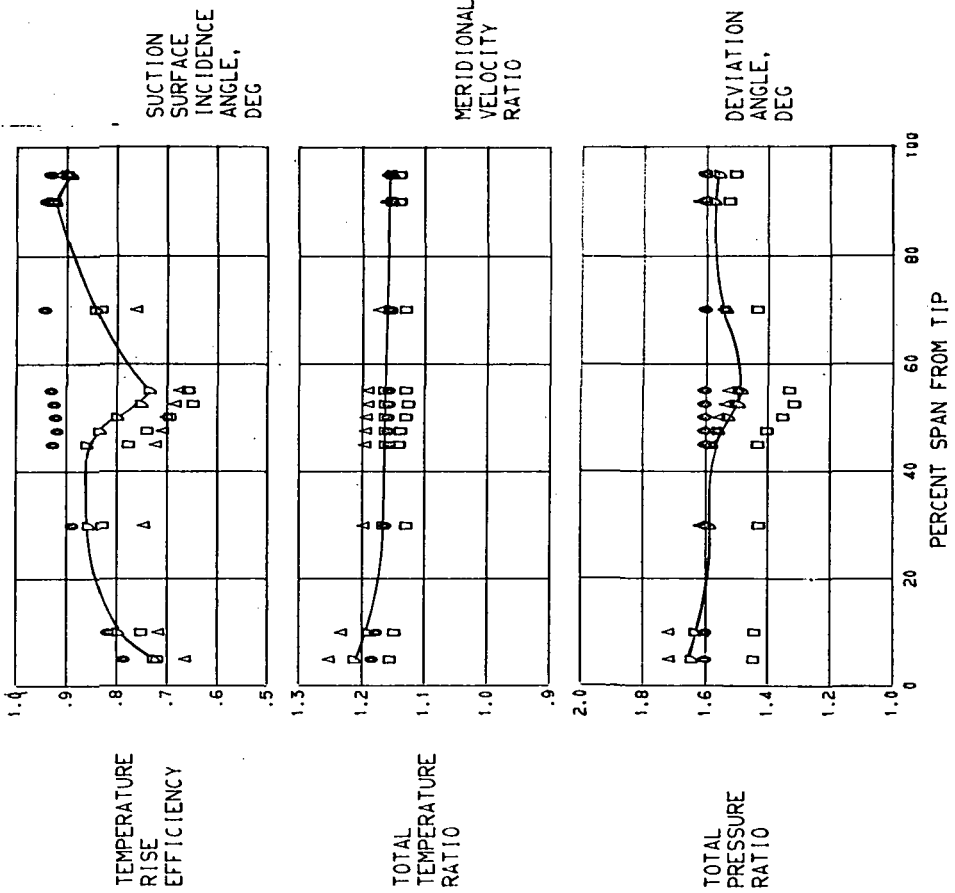

FIGURE 8. - OVERALL PERFORMANCE FOR ROTOR 17.



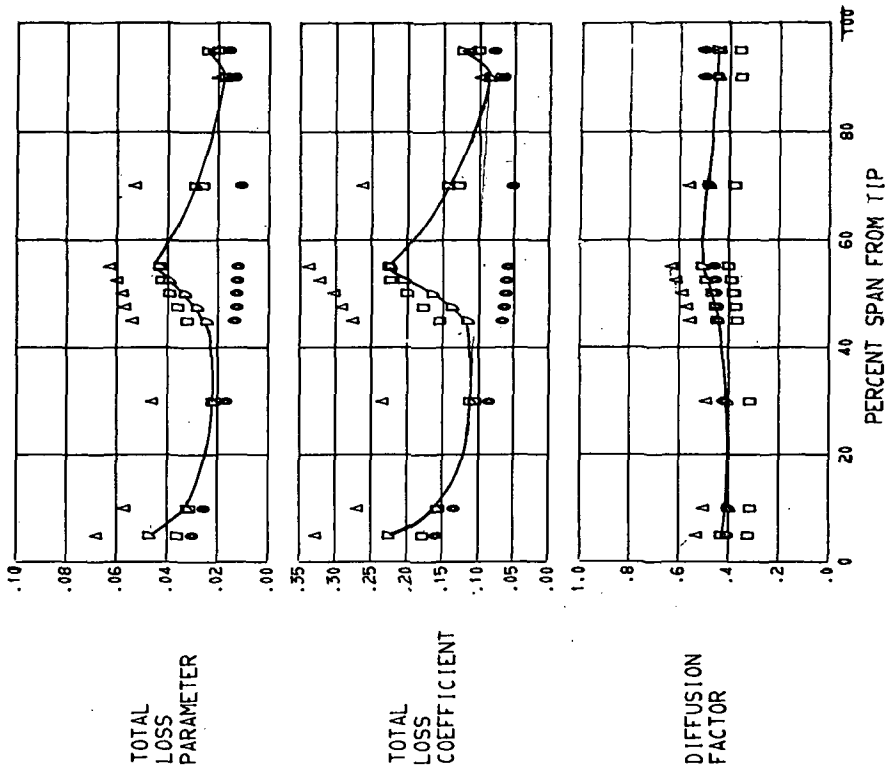

FIGURE 9. - RADIAL DISTRIBUTION OF PERFORMANCE FOR ROTOR 17, 100 PERCENT DESIGN SPEED.

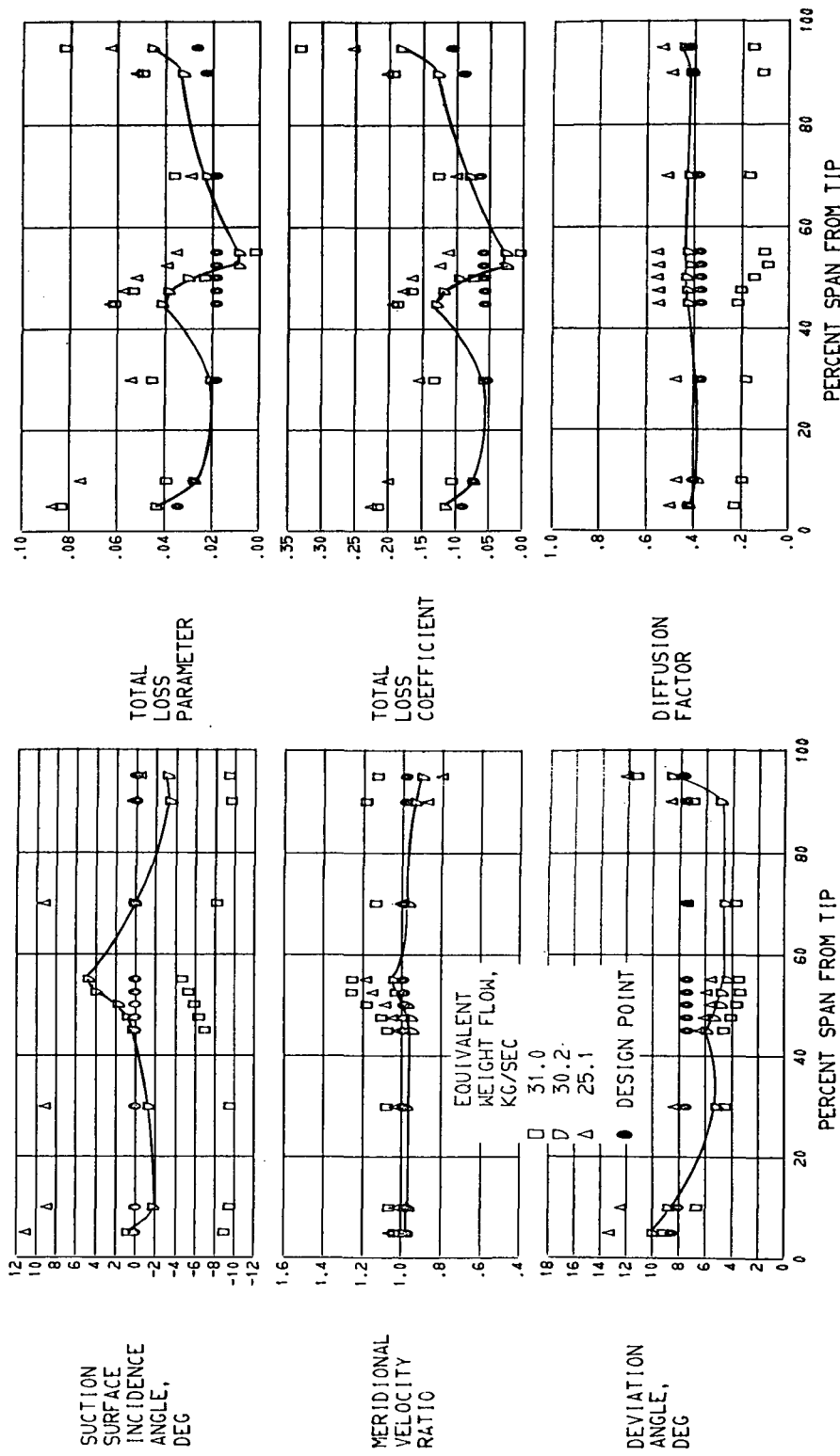
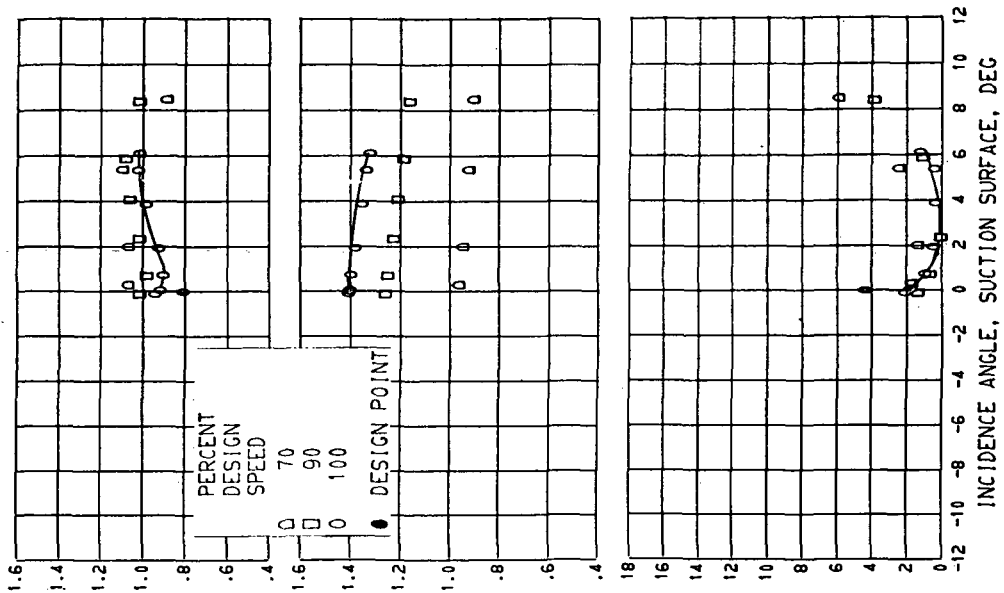
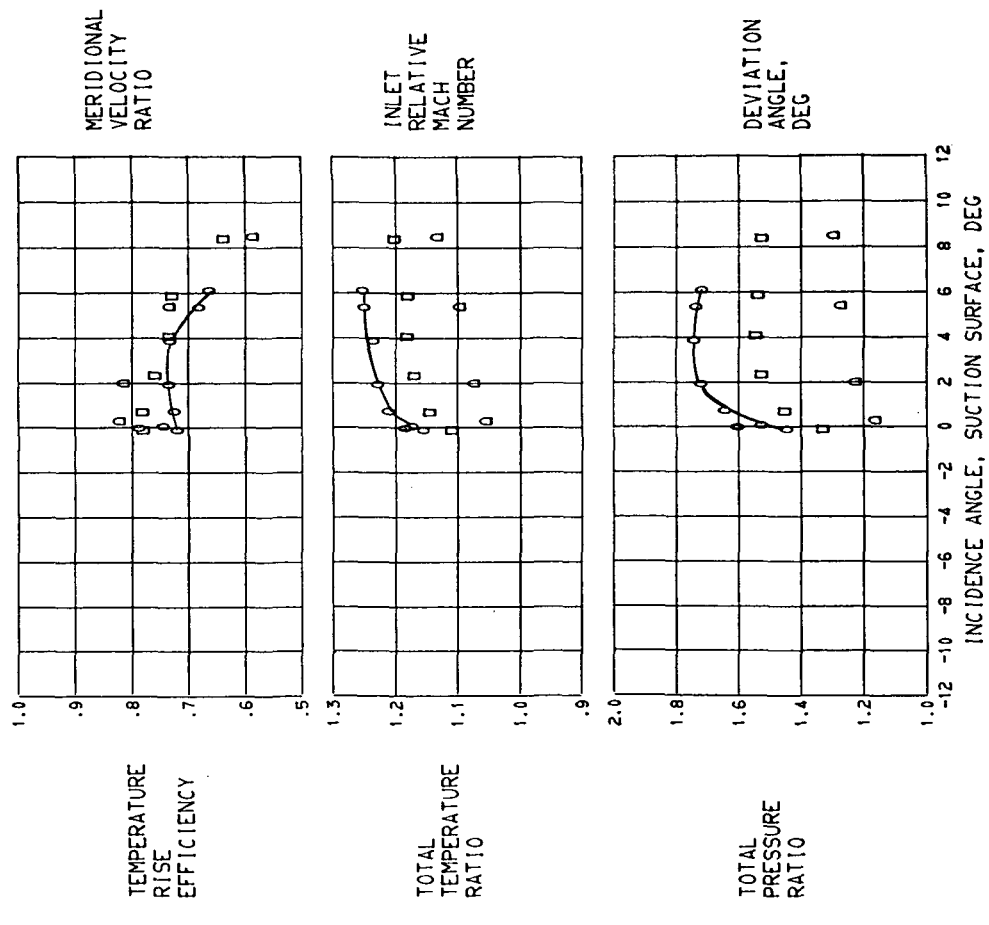

FIGURE 10. - RADIAL DISTRIBUTION OF PERFORMANCE FOR STATOR 12. 100 PERCENT DESIGN SPEED.



(A) CONTINUED. 5.0 PERCENT SPAN.



(A) 5.0 PERCENT SPAN.

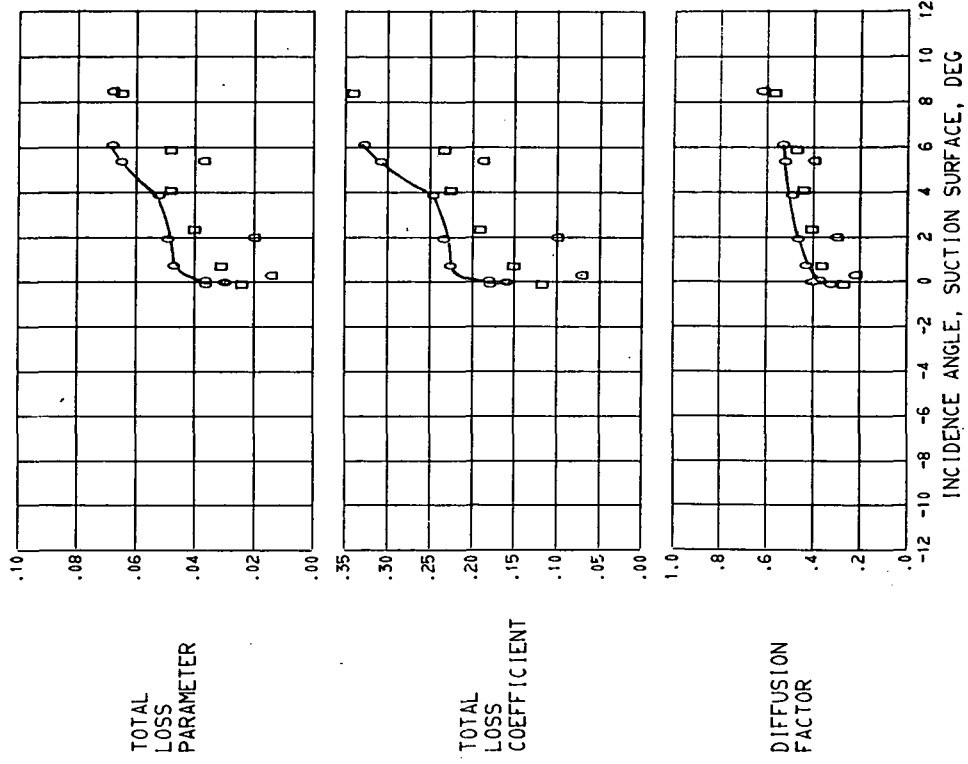

(A) 5.0 PERCENT SPAN.

FIGURE 11. - BLADE ELEMENT PERFORMANCE FOR ROTOR 17.

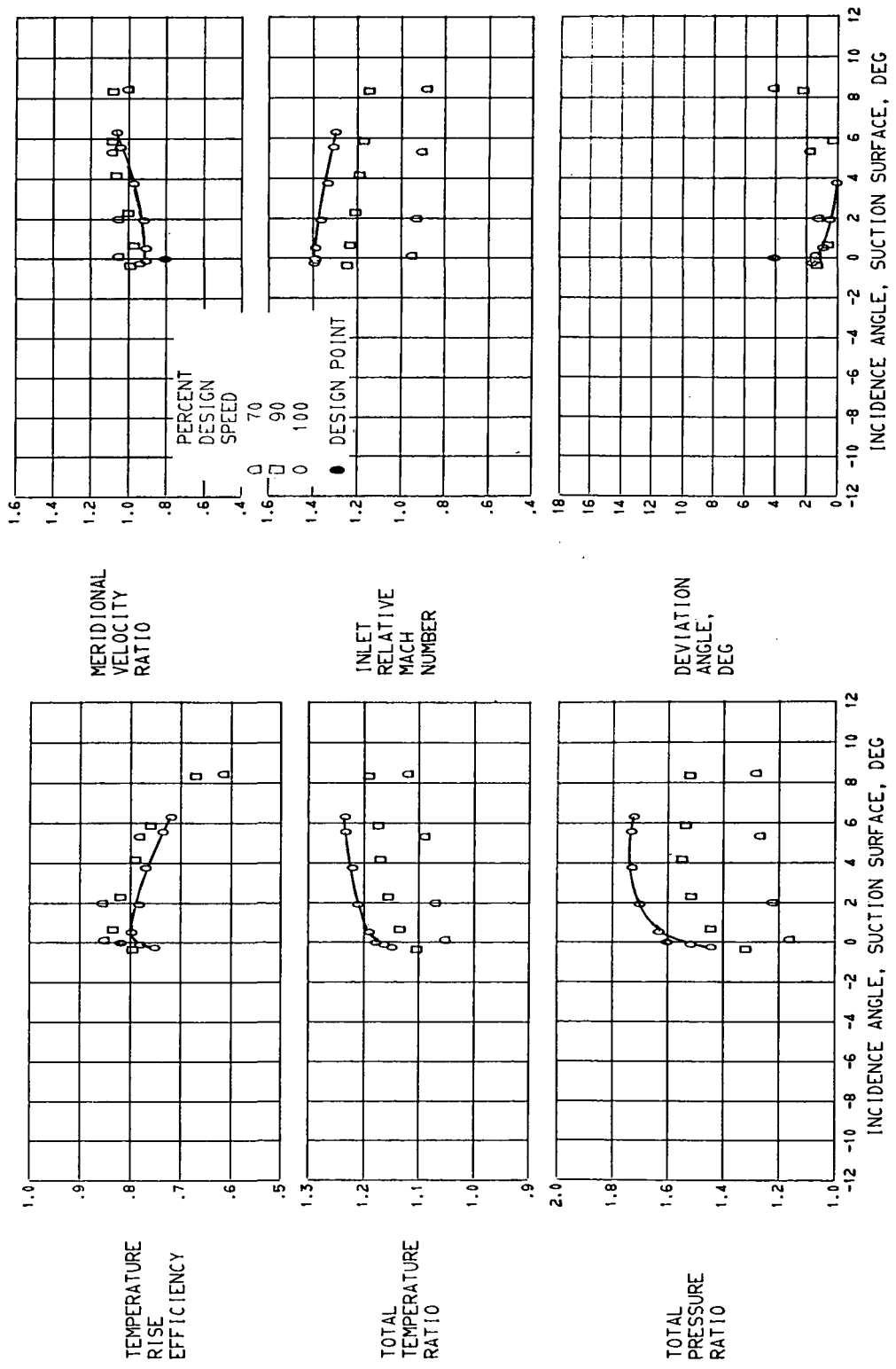

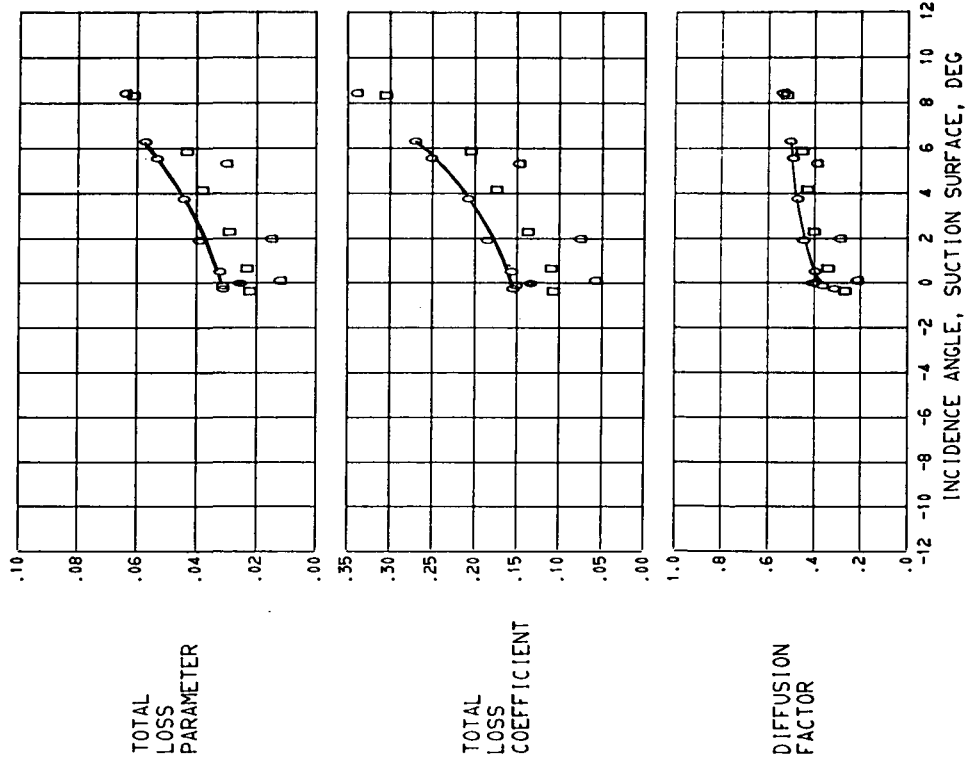

(B) 10.0 PERCENT SPAN.

FIGURE 11. - BLADE ELEMENT PERFORMANCE FOR ROTOR 17.

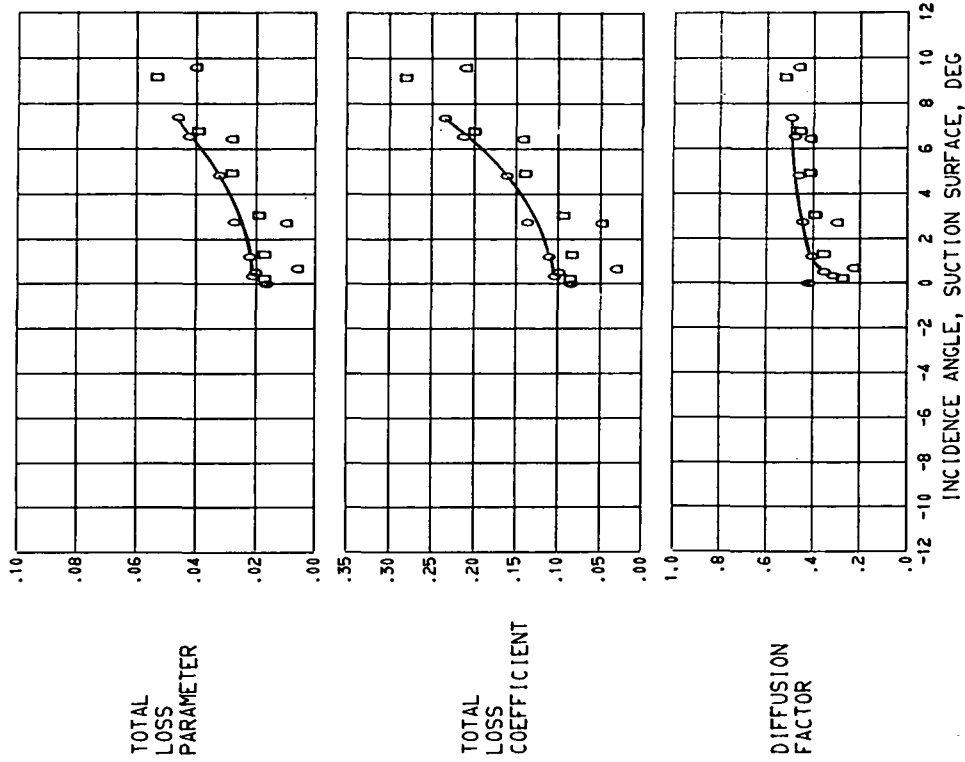

(C) 30.0 PERCENT SPAN.
 FIGURE 11. - BLADE ELEMENT PERFORMANCE FOR ROTOR 17.

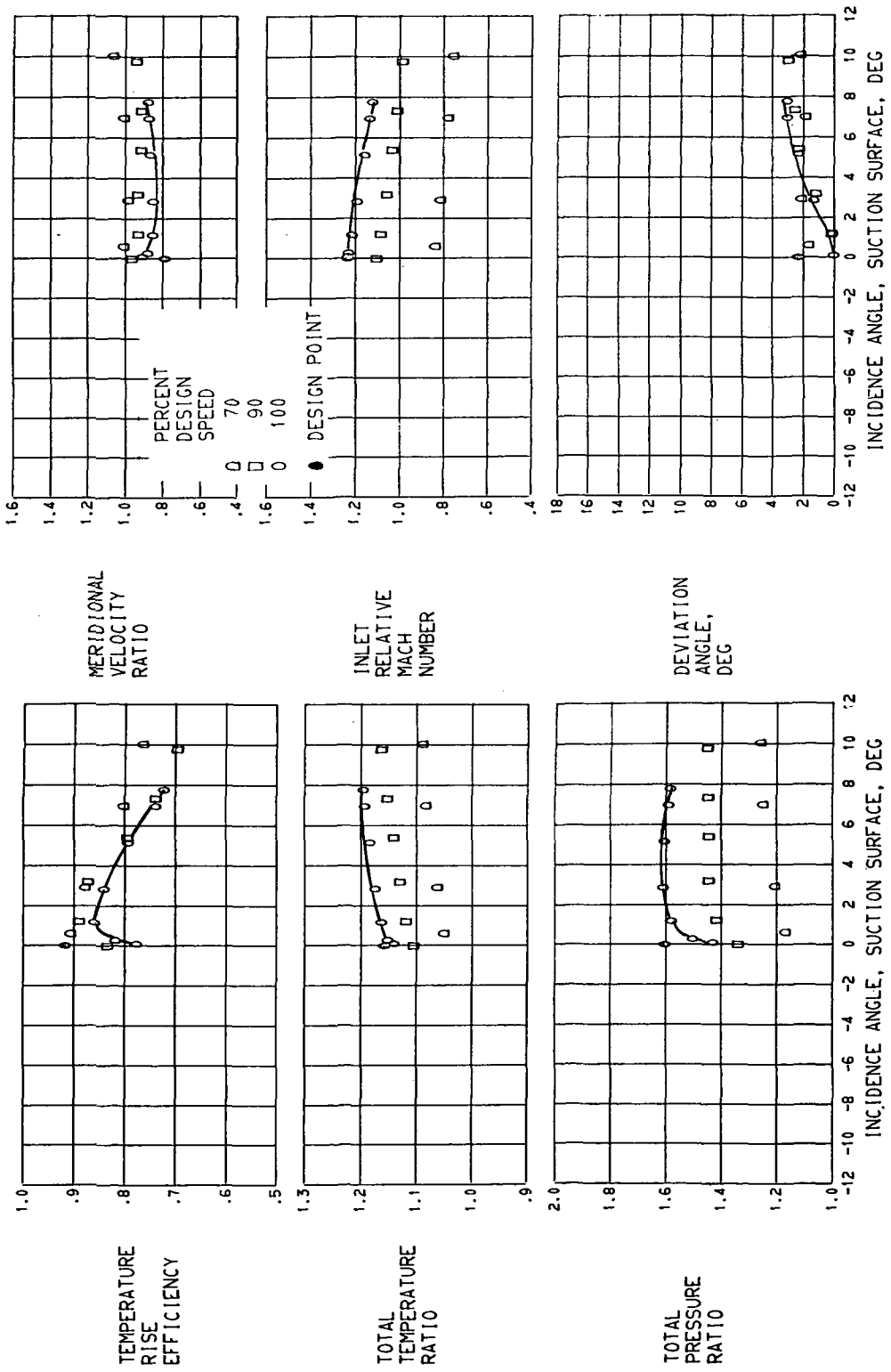

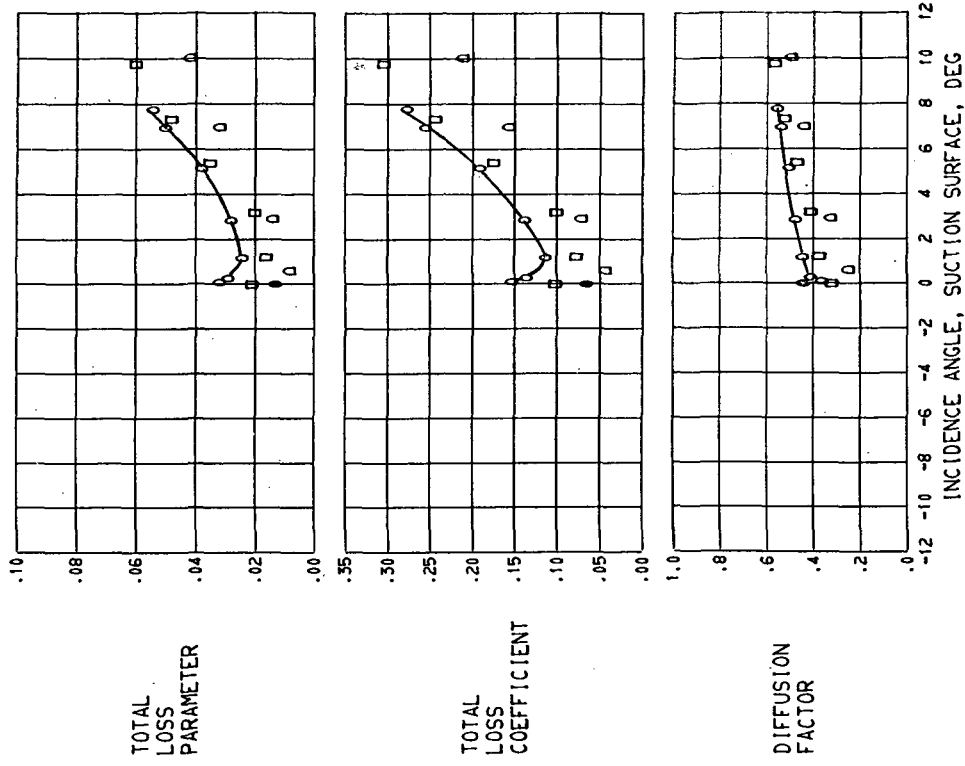

(D) 45.0 PERCENT SPAN.

FIGURE 11. - BLADE ELEMENT PERFORMANCE FOR ROTOR 17.

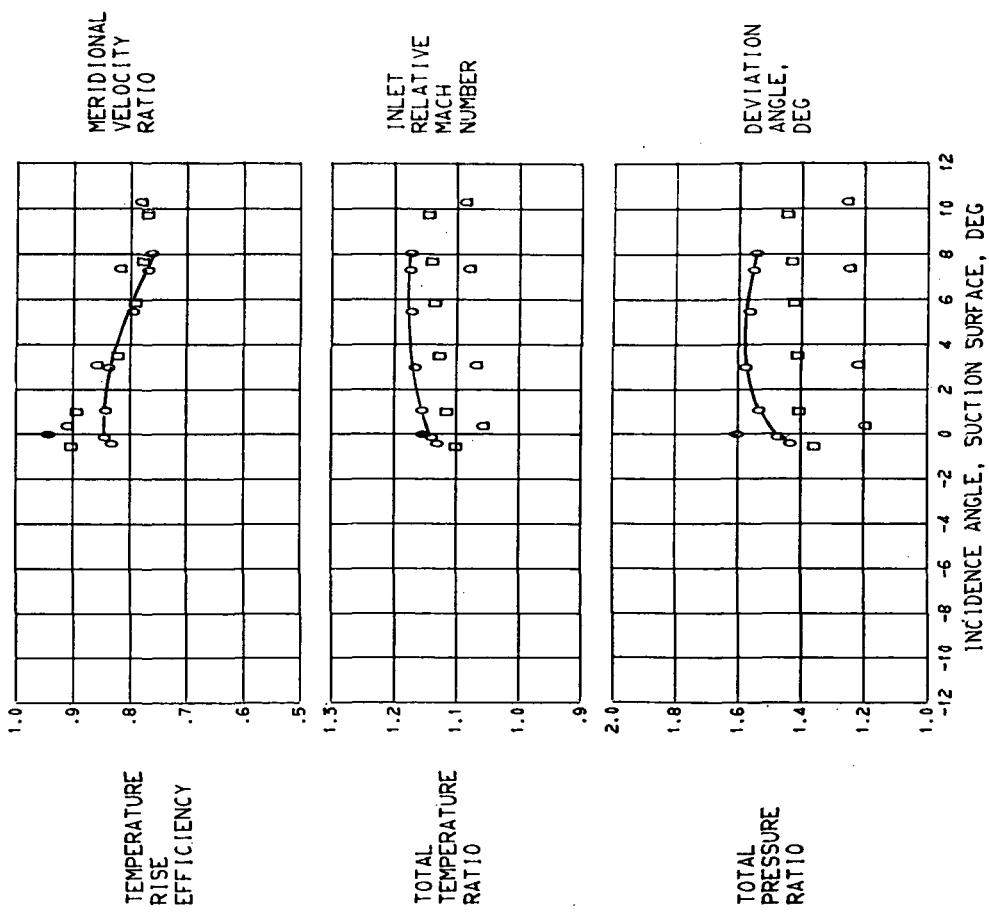
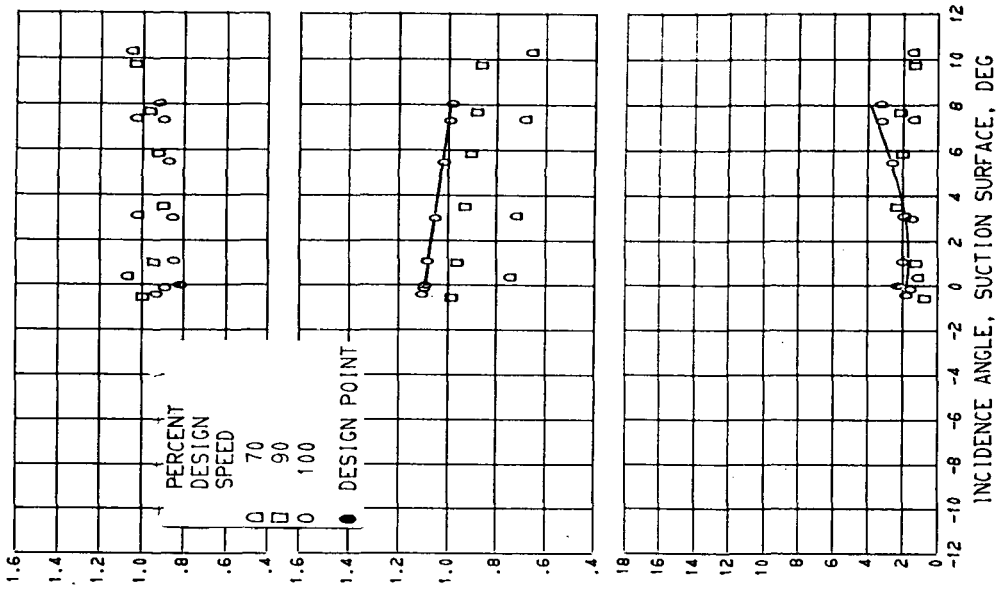

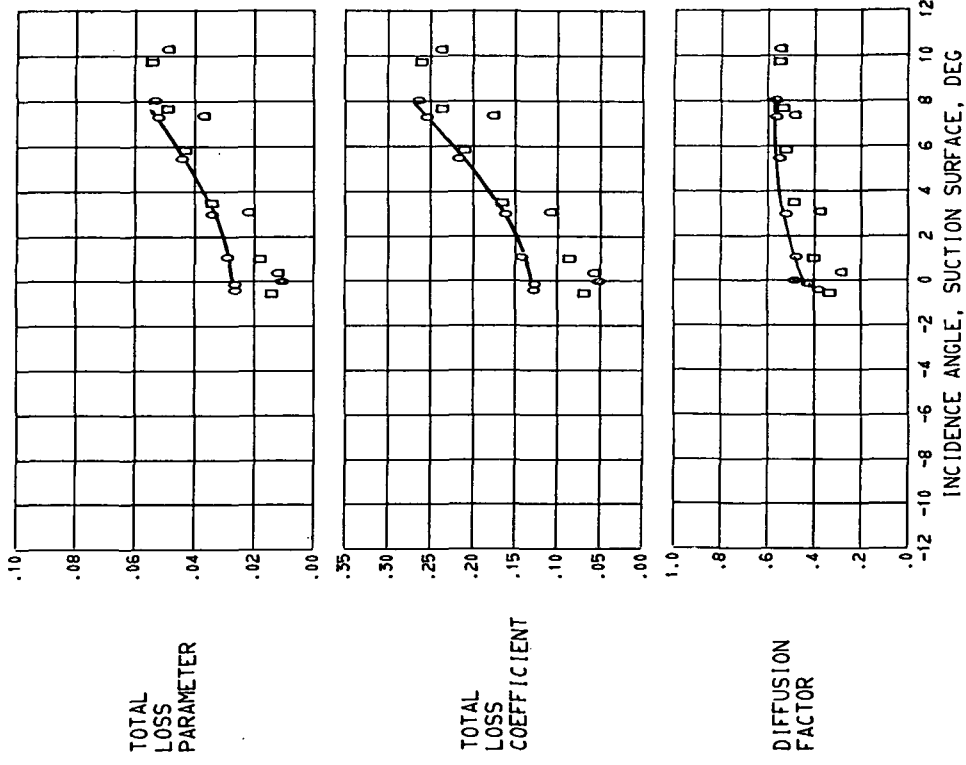
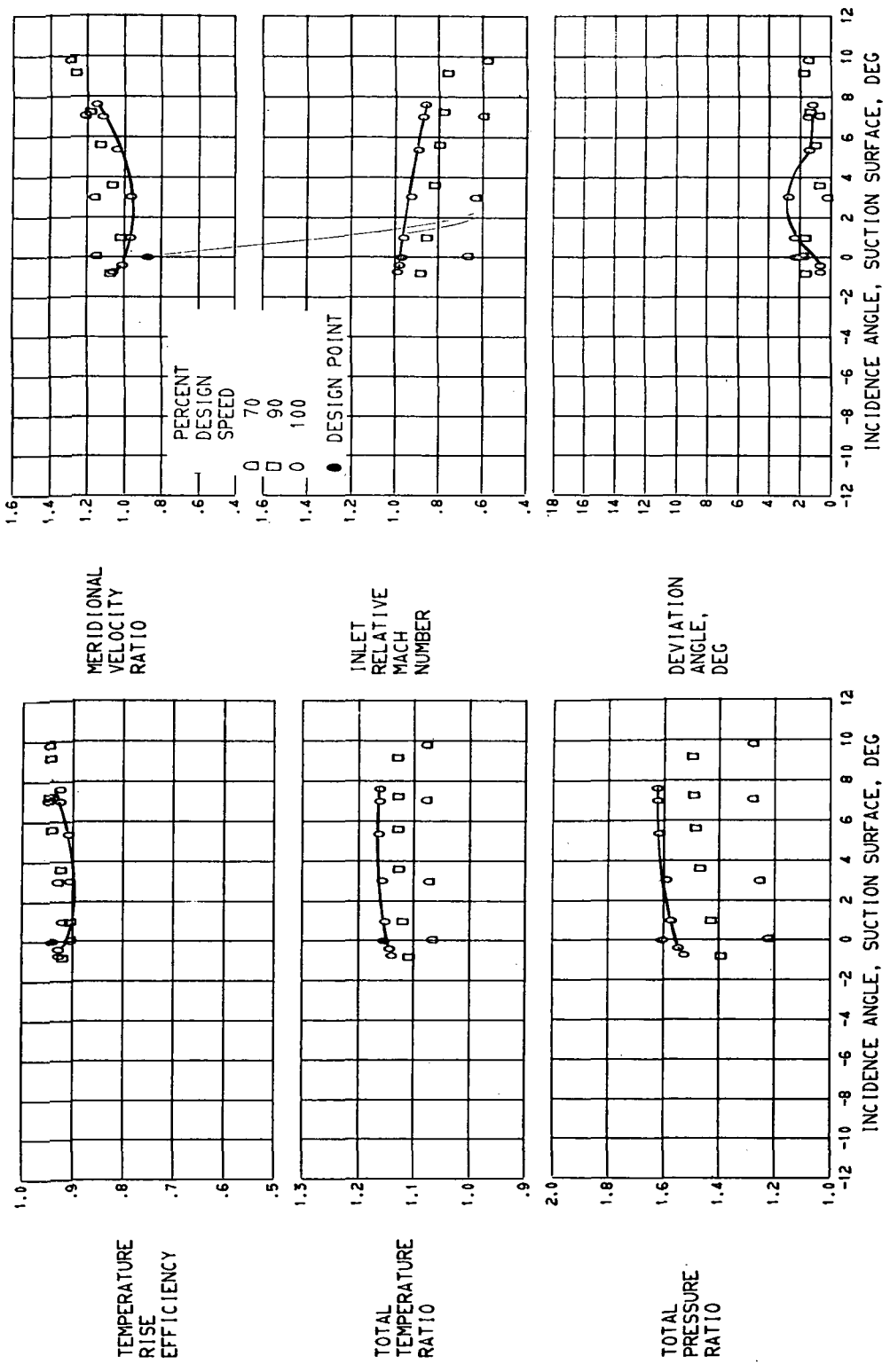
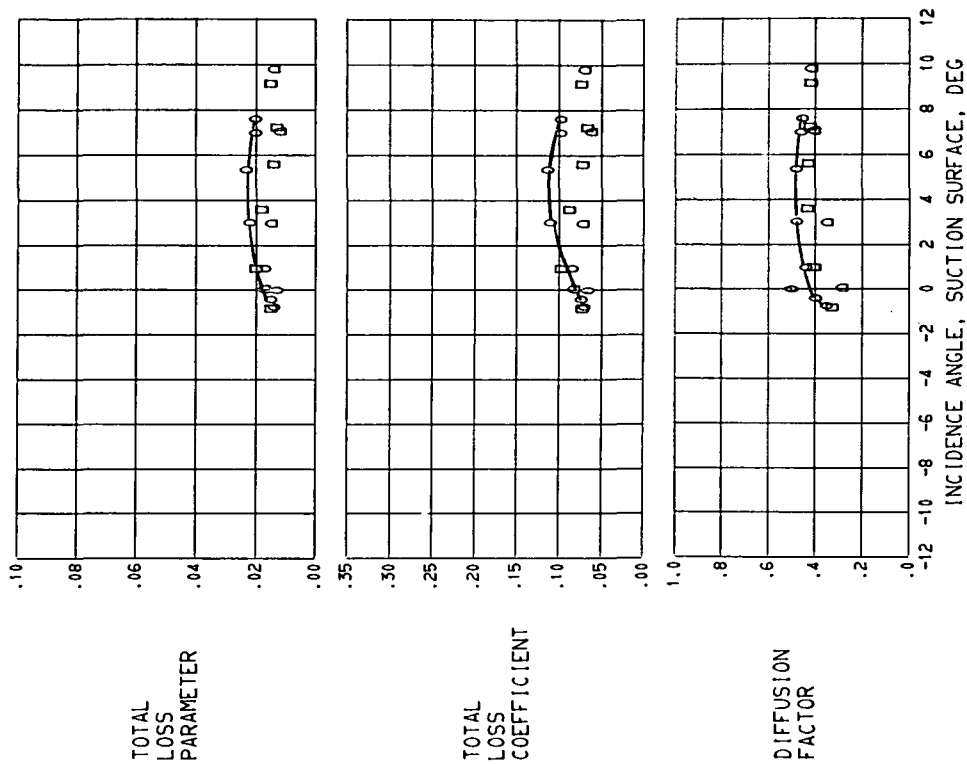
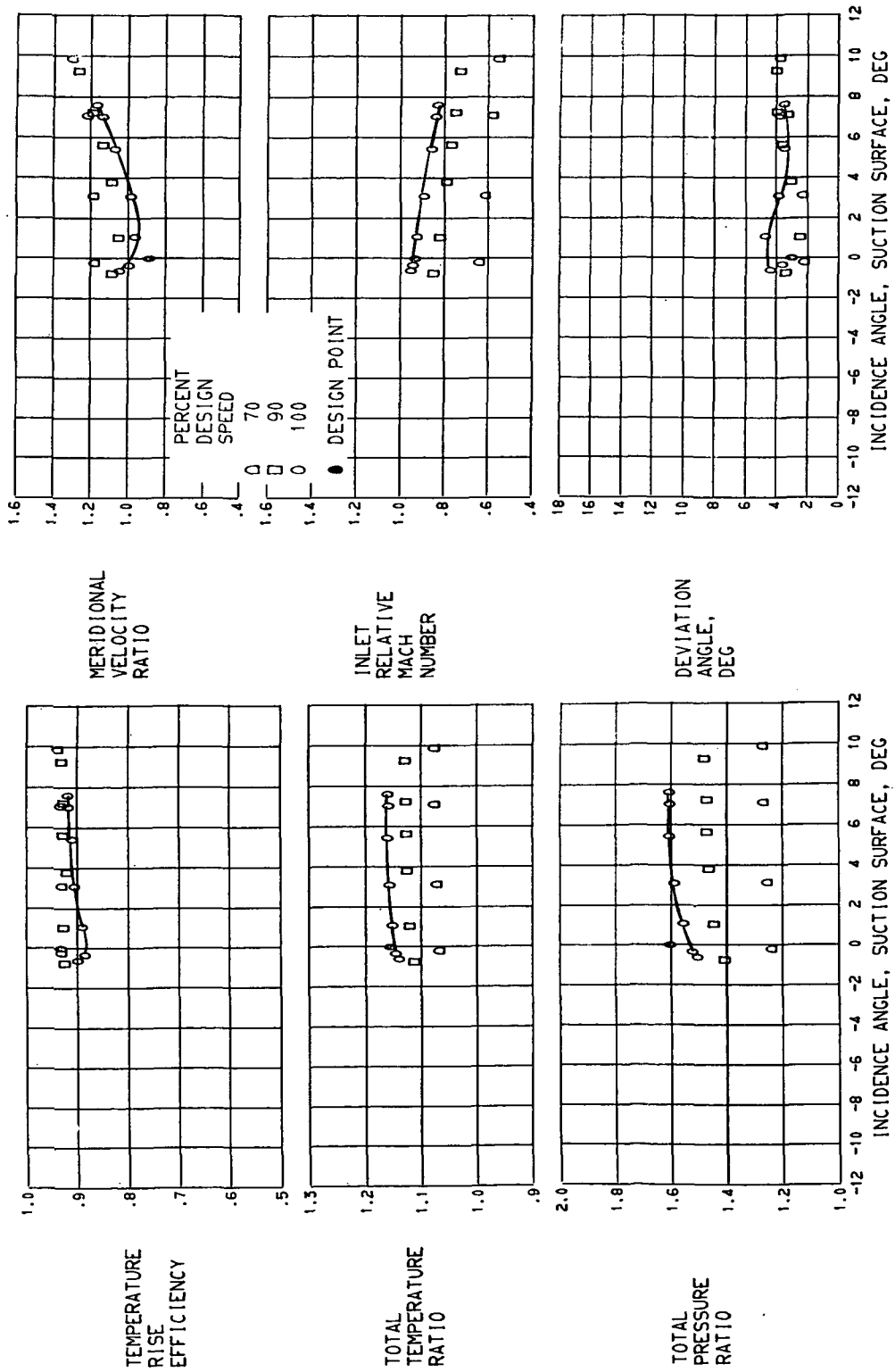

FIGURE 11. - BLADE ELEMENT PERFORMANCE FOR ROTOR 17.
(E) 70.0 PERCENT SPAN.





(F) 90.0 PERCENT SPAN.
 FIGURE 11. - BLADE ELEMENT PERFORMANCE FOR ROTOR 17.



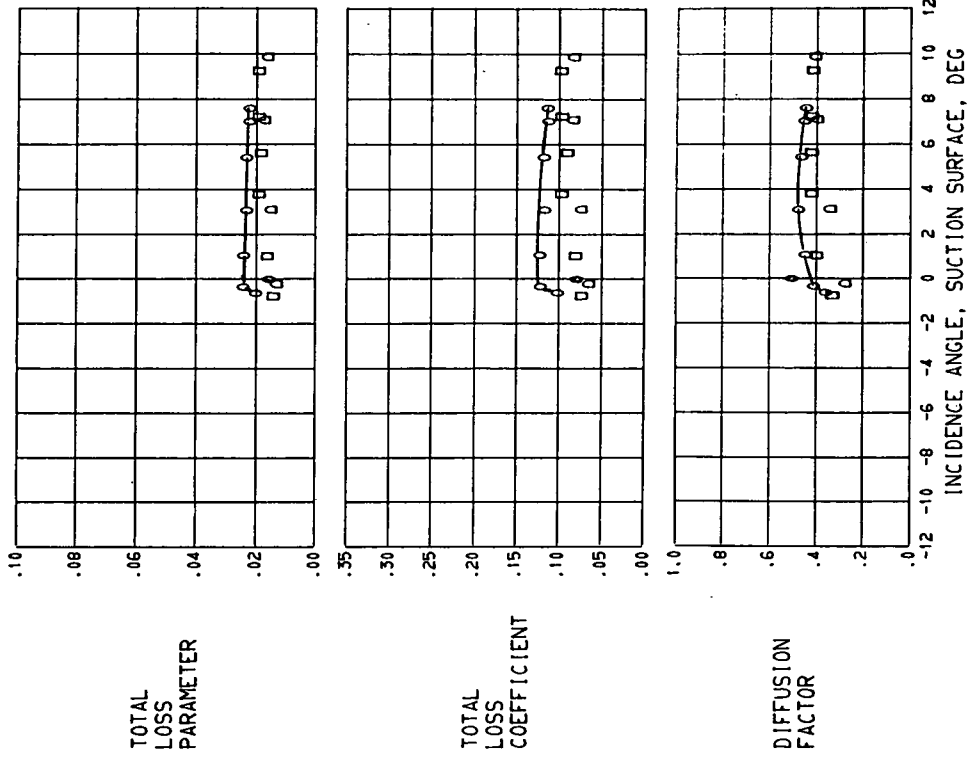

(G) 95.0 PERCENT SPAN.

FIGURE 11. - BLADE ELEMENT PERFORMANCE FOR ROTOR 17.

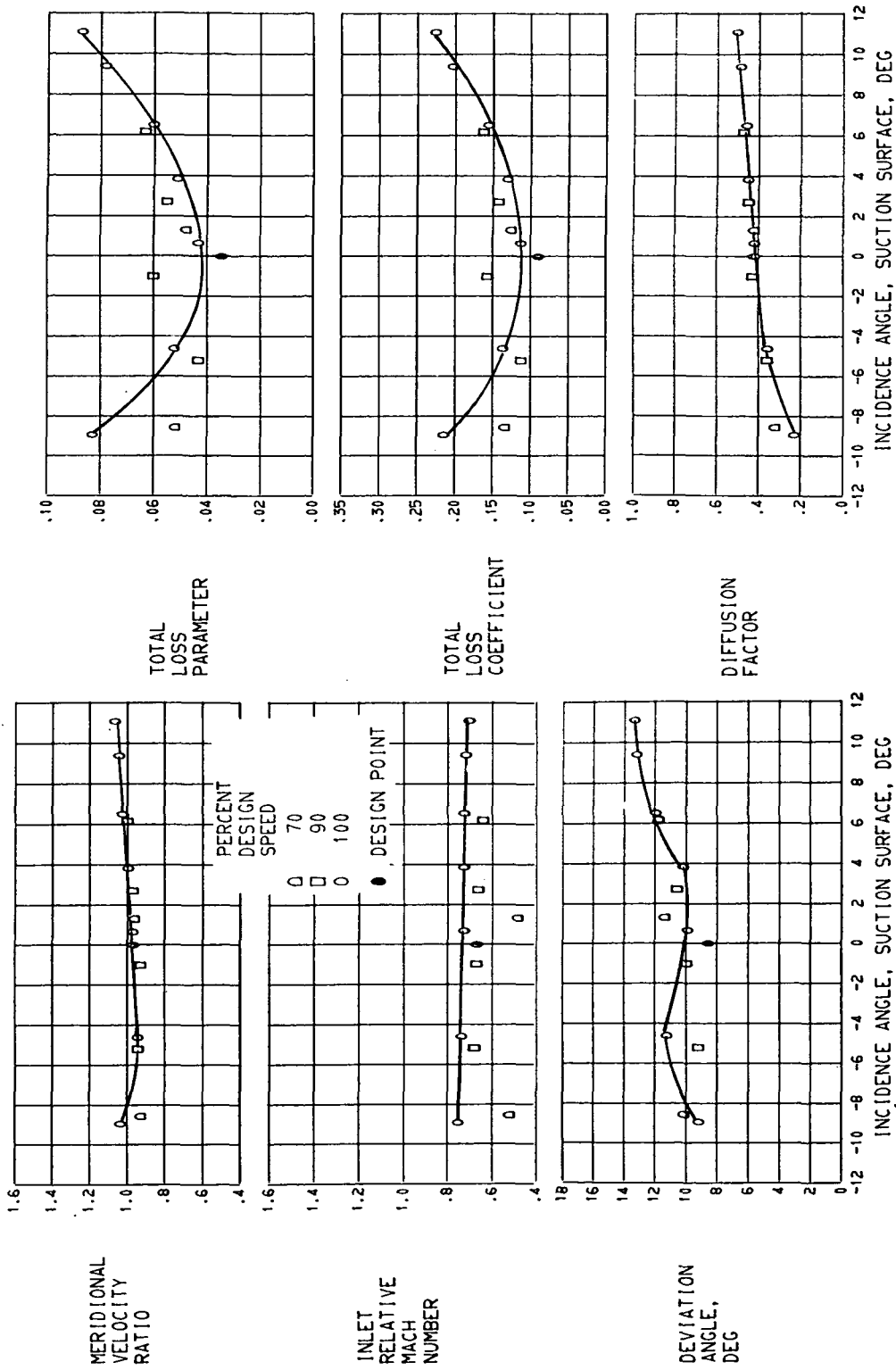

(A) 5.0 PERCENT SPAN.

FIGURE 12. - BLADE ELEMENT PERFORMANCE FOR STATOR 12.

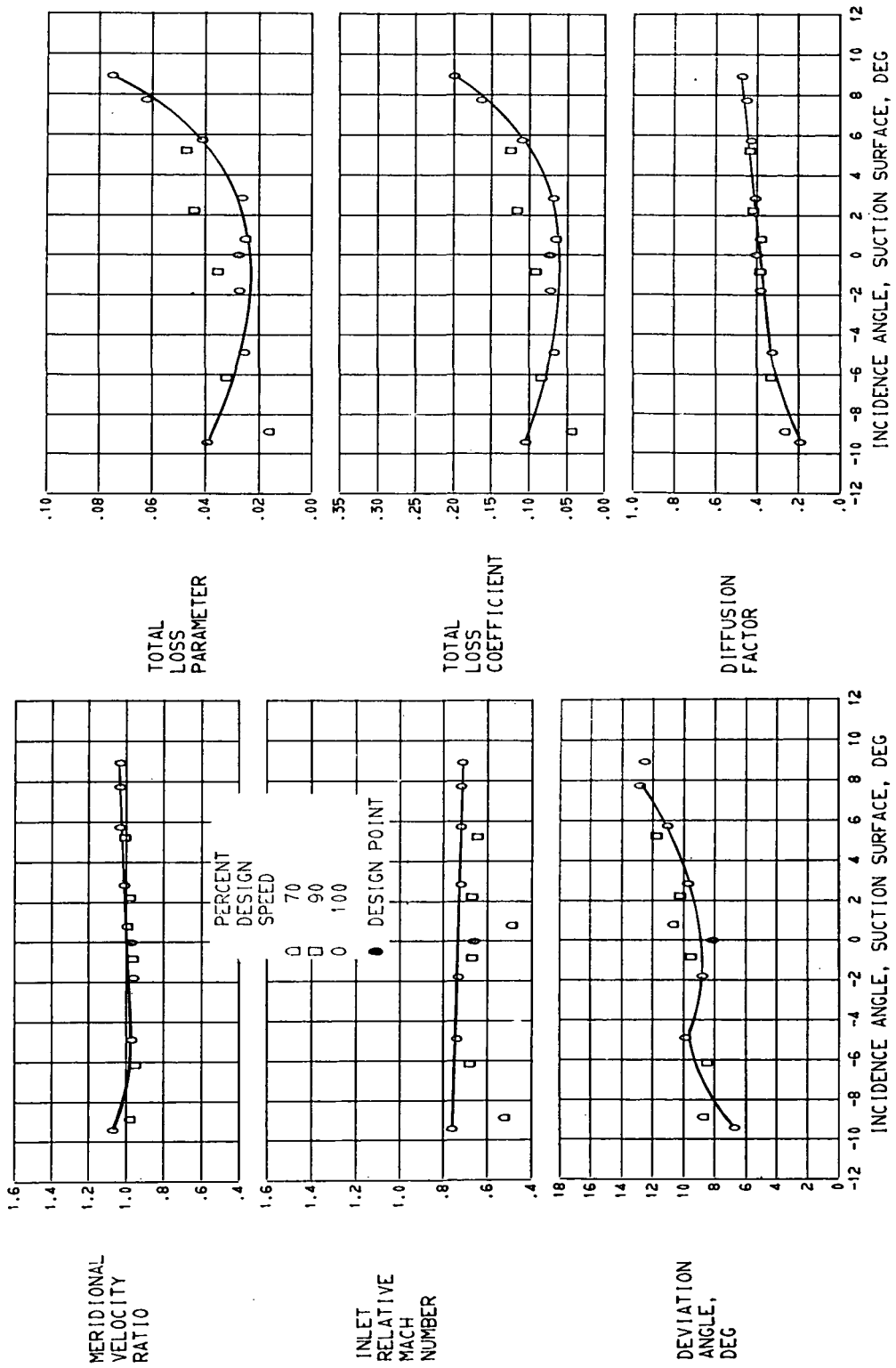

(B) 10.0 PERCENT SPAN.

FIGURE 12. - BLADE ELEMENT PERFORMANCE FOR STATOR 12.

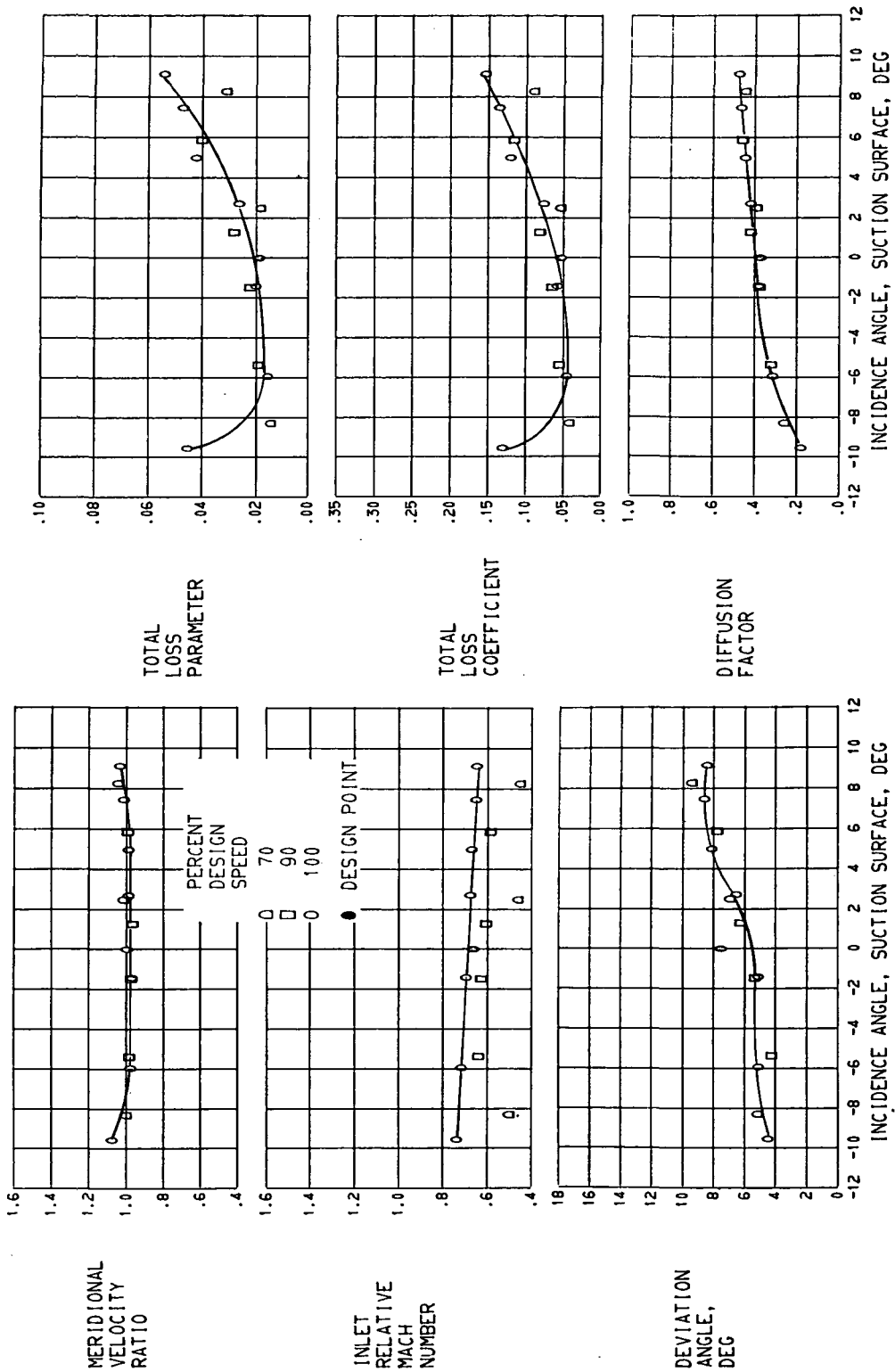

(C) 30.0 PERCENT SPAN.
 FIGURE 12. - BLADE ELEMENT PERFORMANCE FOR STATOR 12.

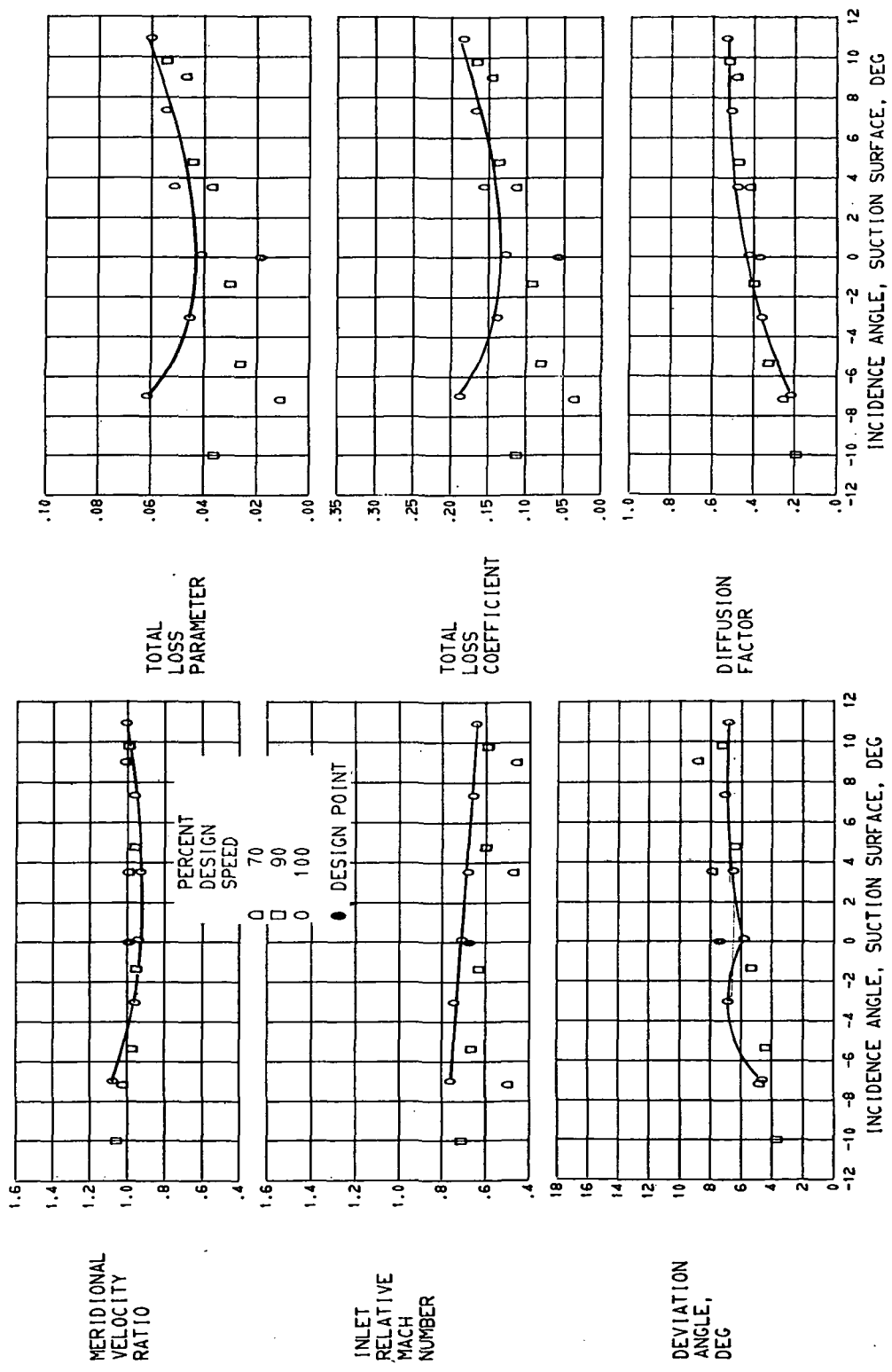

(D) 45.0 PERCENT SPAN.
 FIGURE 12. - BLADE ELEMENT PERFORMANCE FOR STATOR 12.

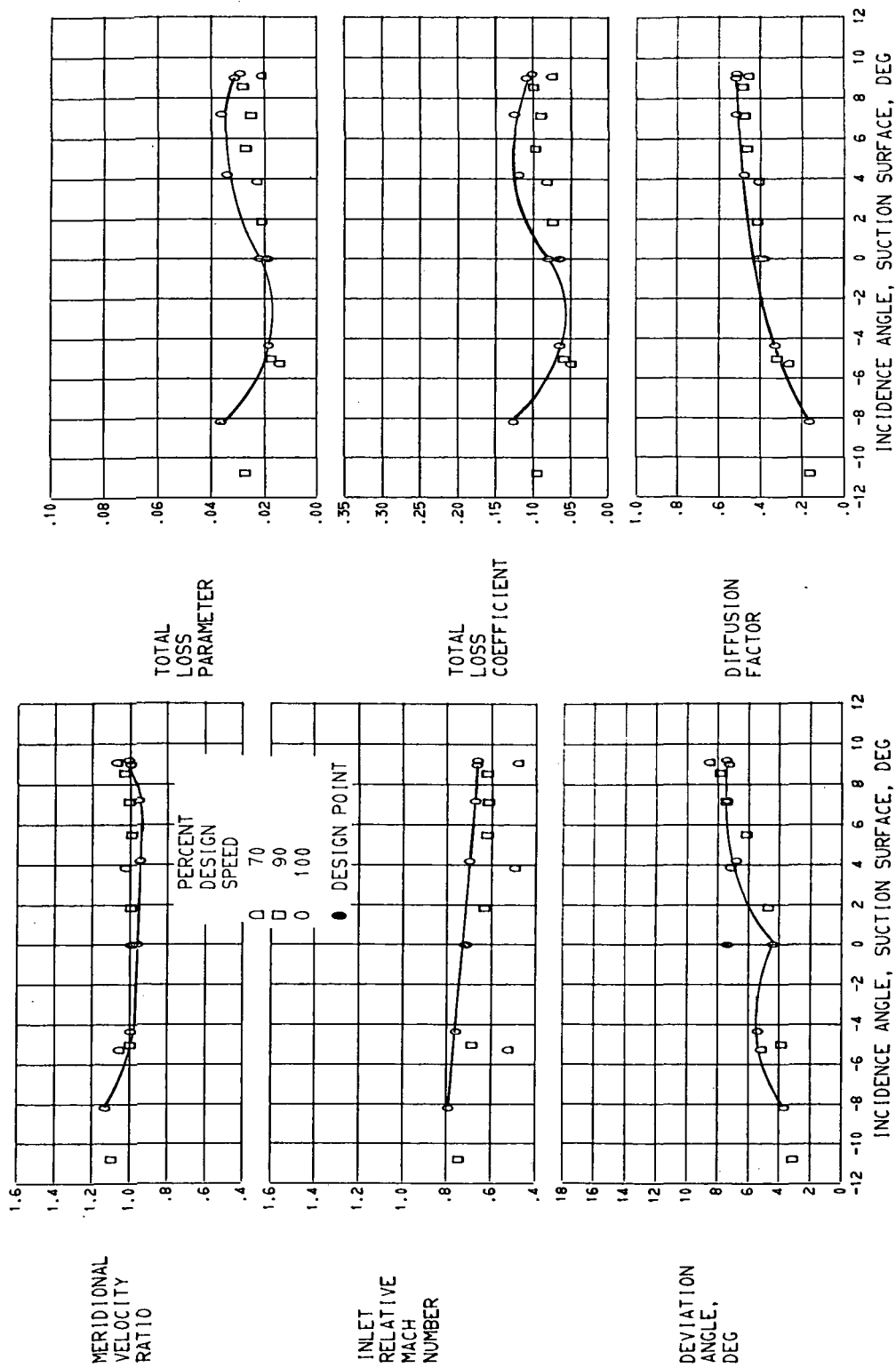

(E) 70.0 PERCENT SPAN.
 FIGURE 12. - BLADE ELEMENT PERFORMANCE FOR STATOR 12.

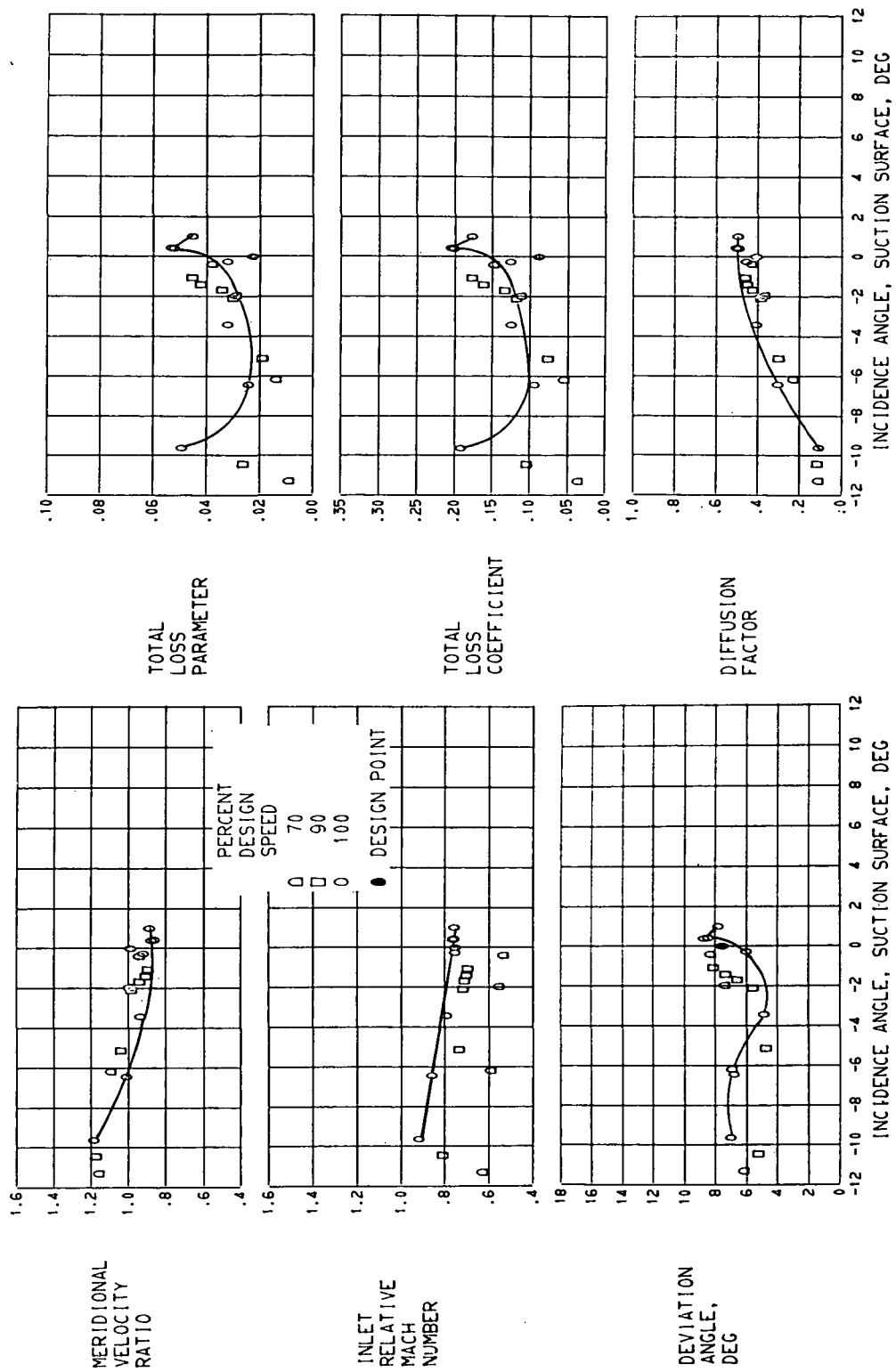

(F) 90.0 PERCENT SPAN.

FIGURE 12. - BLADE ELEMENT PERFORMANCE FOR STATOR 12.

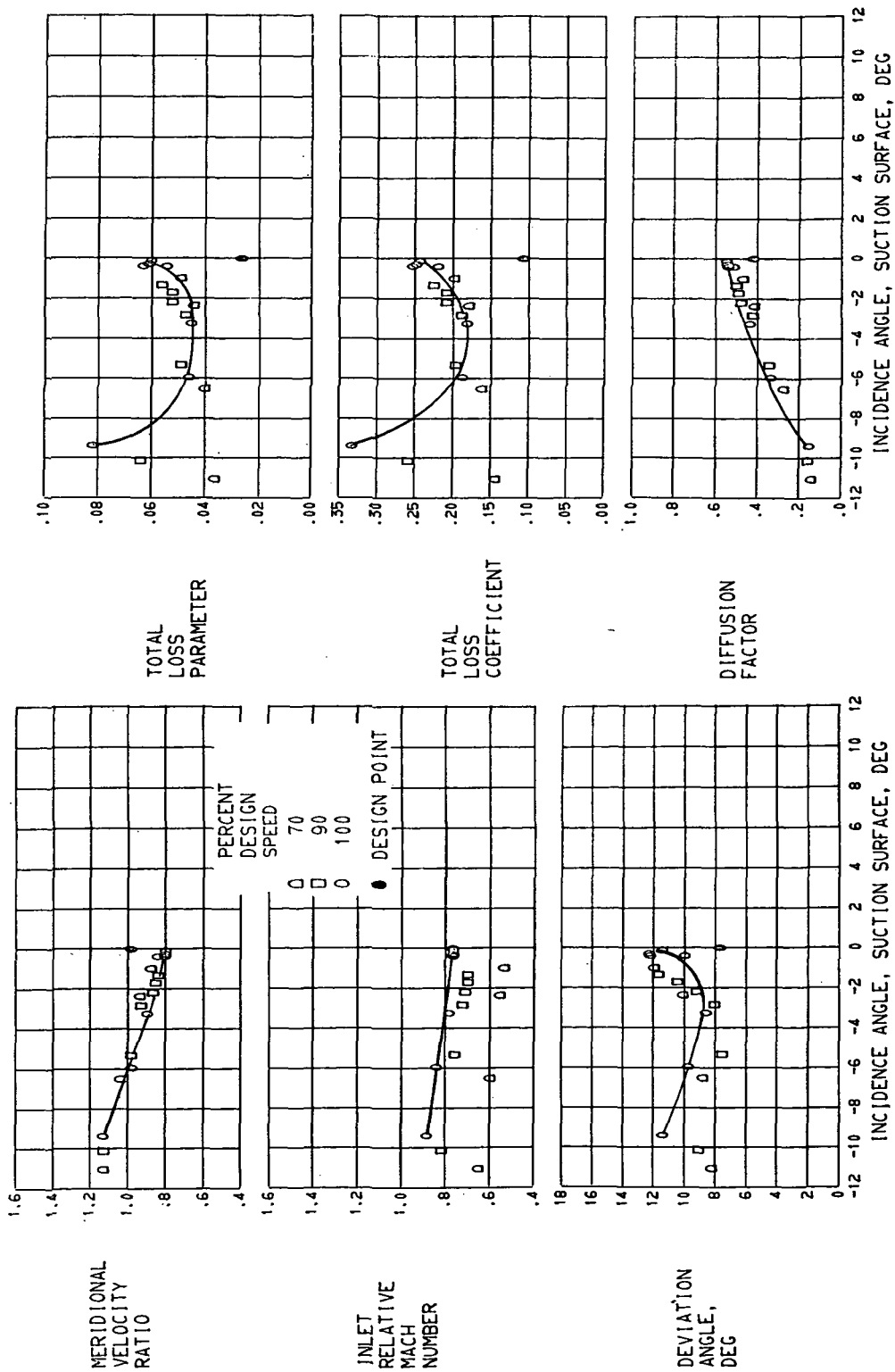

(G) 95.0 PERCENT SPAN.
 FIGURE 12. - BLADE ELEMENT PERFORMANCE FOR STATOR 12.



POSTMASTER : If Undeliverable (Section 158
Postal Manual) Do Not Return

"The aeronautical and space activities of the United States shall be conducted so as to contribute . . . to the expansion of human knowledge of phenomena in the atmosphere and space. The Administration shall provide for the widest practicable and appropriate dissemination of information concerning its activities and the results thereof."

—NATIONAL AERONAUTICS AND SPACE ACT OF 1958

NASA SCIENTIFIC AND TECHNICAL PUBLICATIONS

TECHNICAL REPORTS: Scientific and technical information considered important, complete, and a lasting contribution to existing knowledge.

TECHNICAL NOTES: Information less broad in scope but nevertheless of importance as a contribution to existing knowledge.

TECHNICAL MEMORANDUMS: Information receiving limited distribution because of preliminary data, security classification, or other reasons. Also includes conference proceedings with either limited or unlimited distribution.

CONTRACTOR REPORTS: Scientific and technical information generated under a NASA contract or grant and considered an important contribution to existing knowledge.

TECHNICAL TRANSLATIONS: Information published in a foreign language considered to merit NASA distribution in English.

SPECIAL PUBLICATIONS: Information derived from or of value to NASA activities. Publications include final reports of major projects, monographs, data compilations, handbooks, sourcebooks, and special bibliographies.

TECHNOLOGY UTILIZATION PUBLICATIONS: Information on technology used by NASA that may be of particular interest in commercial and other non-aerospace applications. Publications include Tech Briefs, Technology Utilization Reports and Technology Surveys.

Details on the availability of these publications may be obtained from:

SCIENTIFIC AND TECHNICAL INFORMATION OFFICE

NATIONAL AERONAUTICS AND SPACE ADMINISTRATION

Washington, D.C. 20546