

N74-10027

**NASA TECHNICAL
MEMORANDUM**

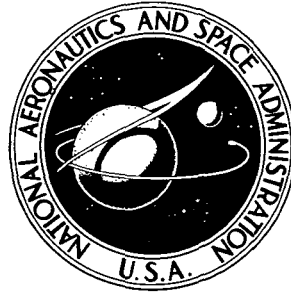

NASA TM X-2905

NASA TM X-2905

**CASE FILE
COPY**

**PERFORMANCE OF TRANSONIC FAN STAGE
WITH WEIGHT FLOW PER UNIT ANNULUS
AREA OF 198 KILOGRAMS PER SECOND
PER SQUARE METER (40.6 (LB/SEC)/FT²)**

by George Kovich, Royce D. Moore, and Donald C. Urasek

Lewis Research Center

Cleveland, Ohio 44135

1. Report No. NASA TM X-2905	2. Government Accession No.	3. Recipient's Catalog No.	
4. Title and Subtitle PERFORMANCE OF TRANSONIC FAN STAGE WITH WEIGHT FLOW PER UNIT ANNULUS AREA OF 198 KILOGRAMS PER SECOND PER SQUARE METER (40.6 (LB/SEC)/FT²)		5. Report Date November 1973	6. Performing Organization Code
		8. Performing Organization Report No. E-7205	10. Work Unit No. 501-24
7. Author(s) George Kovich, Royce D. Moore, and Donald C. Urasek		11. Contract or Grant No.	
9. Performing Organization Name and Address Lewis Research Center National Aeronautics and Space Administration Cleveland, Ohio 44135		13. Type of Report and Period Covered Technical Memorandum	
		14. Sponsoring Agency Code	
12. Sponsoring Agency Name and Address National Aeronautics and Space Administration Washington, D. C. 20546		15. Supplementary Notes	
16. Abstract <p>The overall and blade-element performance are presented for an air compressor stage designed to study the effect of weight flow per unit annulus area on efficiency and flow range. At the design speed of 424.8 m/sec the peak efficiency of 0.81 occurred at the design weight flow and a total pressure ratio of 1.56. Design pressure ratio and weight flow were 1.57 and 29.5 kg/sec (65.0 lb/sec), respectively. Stall margin at design speed was 19 percent based on the weight flow and pressure ratio at peak efficiency and at stall.</p>			
17. Key Words (Suggested by Author(s)) Turbomachinery; Compressors; Transonic compressors; Axial flow compressors; Turbofans		18. Distribution Statement Unclassified - unlimited	
19. Security Classif. (of this report) Unclassified	20. Security Classif. (of this page) Unclassified	21. No. of Pages 91	22. Price* Domestic, \$3.75 Foreign, \$6.25

PERFORMANCE OF TRANSONIC FAN STAGE WITH WEIGHT FLOW PER
UNIT ANNULUS AREA OF 198 KILOGRAMS PER SECOND
PER SQUARE METER (40.6 (LB/SEC)/FT²)

by George Kovich, Royce D. Moore, and Donald C. Urasek
Lewis Research Center

SUMMARY

The overall performance and the blade-element performance are presented for a transonic axial-flow air compressor stage designed to study the effects of weight flow per unit annulus area on efficiency and flow range. The rotor is designed for a weight flow per unit annulus area of 198.2 kilograms per second per square meter and a tip speed of 424.8 meters per second. Design values of weight flow and pressure ratio are 29.5 kilograms per second and 1.57, respectively.

At design speed the peak efficiency of 0.81 occurred at an equivalent weight flow of 29.5 kilograms per second with a total pressure ratio of 1.56. Stall margin at design speed was 19 percent, based on weight flow and pressure ratio at peak efficiency and at stall.

The radial survey data indicate that the rotor-blade dampers had a considerable effect on the blade-element losses. Losses at measured peak efficiency in general were higher than design values for the rotor, while stator-blade losses were for the most part equal to design values except in the region behind the dampers and near the end walls. Suction-surface incidence angles corresponding to minimum losses were within $\pm 1^\circ$ of design values for the rotor. The stator minimum losses could be considered constant over a range of suction-surface incidence angles from about -6° to $+2^\circ$ for most of the blade span.

Rotor-blade deviation angles were as much as 3.5° less than the design values except in a portion of the damper region. Stator deviation angles exceeded design values by as much as 5° in the tip and hub regions but were close to design over the rest of the blade.

INTRODUCTION

A research program on axial-flow fans and compressors for advanced airbreathing engines is currently being conducted at the NASA Lewis Research Center. This program is primarily directed toward reducing the size and weight of fans and compressors while maintaining high levels of performance. In support of this program, experimental studies are being conducted to evaluate the effects of blade solidity, blade aspect ratio, blade loading, area margin above choke, different blade shapes, weight flow per unit annulus area, velocity ratio, and blade spacing on efficiency and flow range.

A series of tests are being conducted to evaluate the effect of weight flow per unit annulus area on the performance of axial-flow fan stages. Three stages were designed for weight flows per unit annulus area of 178, 198, and 208 kilograms per second per square meter. All three stages were designed to produce a pressure ratio of 1.57, and all had the same meridional flow path geometry. The performance of the first stage, with a weight flow of 178 kilograms per second per square meter, is presented in reference 1, and that of the last stage, with a weight flow of 208 kilograms per second per square meter, in reference 2.

This report presents the performance of an axial-flow fan stage designed for 198 kilograms per second per square meter. It presents the aerodynamic design parameters and the overall and blade-element performance. Data were obtained over the stable operating range of the stage for six rotative speeds from 50 to 100 percent of design speed. Blade-element data were obtained for the rotor and the stator at 11 radial positions. The stage discussed in this report has been designated "stage 11-4" with the rotor being rotor 11 and the stator being stator 4. The data in this report are presented in tabular and in machine-plotted form. The symbols and equations are given in appendixes A and B, respectively. The definitions and units used for the tabular data are presented in appendix C.

AERODYNAMIC DESIGN

Three computer programs were used in the design of this compressor stage: the streamline analysis program, the blade geometry program, and the blade coordinate program. These programs are described in references 3 and 4; only a brief description of each is presented in this report.

The streamline analysis program was used to calculate the flow field parameters at several axial locations, including planes approximating the blade leading and trailing edges for both the rotor and stator. The weight flow, rotative speed, flow path geometry, and radial distributions of total pressure and temperature are inputs in this pro-

gram. The program accounts for both streamline curvature and entropy gradients; boundary-layer blockage factors are also included.

The distributions of velocity vector, total pressure, and total temperature calculated in the streamline analysis program are used in the blade geometry program to compute blade geometry parameters. The total loss, which is computed within the program, includes a calculated shock loss (as related to the selected blade shape) and a profile loss. The profile losses used for this stage are based on loss - diffusion factor correlations that include the data presented in reference 1 for the rotor and in reference 5 for the stator.

The blade geometry parameters are used in the blade coordinate program to compute blade elements on conical surfaces, approximating the stream surfaces passing through the blade. The blade elements are then stacked on a line passing through their centers of gravity, and Cartesian blade coordinates, which are used directly in fabrication, are computed.

The overall design parameters for stage 11-4 are listed in table I and the flow path geometry is shown in figure 1. This stage was designed for an overall pressure ratio of 1.57 at a weight flow of 29.5 kilograms per second ($198.2 \text{ (kg/sec)/m}^2$ of annulus area). The design tip speed was 424.8 meters per second. The stage was designed for a tip solidity of 1.30 for the rotor and 1.27 for the stator. This resulted in 44 rotor blades with an aspect ratio of 2.5 and 48 stator blades with an aspect ratio of 2.4.

The blade-element design parameters for rotor 11 are presented in table II. This rotor was designed for a radially constant total pressure ratio of 1.60. The stator blade element design parameters are given in table III. The blade geometry is presented in table IV for rotor 11 and in table V for stator 4. Both the rotor and stator have multiple-circular-arc blade shapes.

The equations used for calculating overall blade-element performance parameters are presented in appendix B. All definitions and units of the parameters presented in the tables are shown in appendix C.

APPARATUS AND PROCEDURE

Compressor Test Facility

The compressor stage was tested in the Lewis single-stage compressor facility (described in detail in ref. 6. A schematic diagram of the facility is shown in fig. 2). Atmospheric air enters the test facility at an inlet located on the roof of the building and flows through the flow measuring orifice and into the plenum chamber upstream of the test stage. The air then passes through the experimental compressor stage into the collector and is exhausted to the atmosphere.

Test Stage

Photographs of the rotor and stator are shown in figures 3 and 4. Each rotor blade has a vibration damper located at about 50 percent span from the outlet rotor tip. The maximum thickness of the damper was 0.213 centimeter. The nonrotating radial tip clearance of the rotor was a nominal 0.050 centimeter at ambient conditions. The axial spacing between the rotor hub trailing edge and the stator hub leading edge was 3.20 centimeters.

Instrumentation

The compressor weight flow was determined from measurements on a calibrated thin-plate orifice. The temperature at the orifice was measured with two Chromel-Alumel thermocouples. Pressures at the orifice were measured by calibrated transducers.

Radial surveys of the flow were made upstream of the rotor, between the rotor and stator, and downstream of the stator (fig. 1). Photographs of the survey probes are shown in figure 5. Total pressure, total temperature, and flow angle were measured with the combination probe (fig. 5(a)), and the static pressure was measured with an 8° C-shaped wedge probe (fig. 5(b)). Each probe was positioned with a null-balancing, stream-directional sensitive control system that automatically alined the probe to the direction of flow. The probes were angularly alined in an air tunnel. One combination probe and one wedge static probe were used at each of the three measuring stations. The thermocouple was of the iron/constantan type.

Inner- and outer-wall static pressure taps were located at the same axial stations as the survey probes. The circumferential locations of both types of survey probes along with inner- and outer-wall static-pressure taps are shown in figure 6. The combination probe downstream of the stator (station 3) was circumferentially traversed one stator blade passage (7.5°) counterclockwise from the nominal value shown.

An electronic speed counter, in conjunction with a magnetic pickup, was used to measure rotative speed (rpm).

The estimated errors of the data based on inherent accuracies of the instrumentation and recording system are as follows:

Weight flow, kg/sec	±0.3
Rotative speed, rpm	±30
Flow angle, deg.	±1
Temperature, K	±0.6
Rotor inlet total pressure, N/cm ²	±0.01
Rotor outlet total pressure, N/cm ²	±0.10
Stator outlet total pressure, N/cm ²	±0.10
Rotor inlet static pressure, N/cm ²	±0.04
Rotor outlet static pressure, N/cm ²	±0.07
Stator outlet static pressure, N/cm ²	±0.07

A further indication of the consistency of the data can be observed by comparing the integrated weight flow at each measuring station with the orifice weight flow in table VI.

Test Procedure

The stage survey data were taken over a range of weight flows from maximum flow to the near-stall conditions. At 70, 90, and 100 percent of design speed, radial surveys were taken at five weight flows. At 50, 60, and 80 percent of design speed, radial surveys were taken for the near-stall weight flow only. Data were recorded at 11 radial positions for each speed and weight flow.

At each radial position the combination probe behind the stator was circumferentially traversed to nine different locations across the stator gap. The wedge probe was set at midgap because previous studies showed that the static pressure across the stator gap was nearly constant. Values of pressure, temperature, and flow angle were recorded at each circumferential position. At the last circumferential position values of pressure, temperature, and flow angle were also recorded at stations 1 and 2. All probes were then traversed to the next radial position, and the circumferential traverse procedure repeated.

At each of the six rotative speeds the back pressure on the stage was increased by closing the sleeve valve in the collector until a stalled condition was detected by a sudden drop in stage outlet total pressure. This pressure was measured by a probe located at midpassage and was recorded on an X-Y plotter. Stall was corroborated by large increases in the measured blade stresses on both rotor and stator along with a sudden increase in noise level.

Calculation Procedure

The measured total temperatures and total pressures were corrected for Mach number and streamline slope. These corrections were based on instrument probe calibrations given in reference 7. The stream static pressure was corrected for Mach number and streamline slope based on an average calibration for the type of probe used.

Because of the physical size of the C-shaped static pressure wedges, it was not possible to obtain static pressure measurements at 5, 10, and 95 percent of span. The static pressure at 95 percent span was obtained by assuming a linear variation in static pressure between the values at the inner wall and the probe measurement at 90 percent span. A similar variation was assumed between the static pressure measurements at the outer wall and the 30 percent span to obtain the static pressure at 5 and 10 percent span.

At each radial position, averaged values of the nine circumferential measurements of pressure, temperature, and flow angle downstream of the stator (station 3) were obtained. The nine values of total temperature were mass averaged to obtain the stator outlet total temperature. The nine values of total pressure were energy averaged. The measured values of pressure, temperature, and flow angle were used to calculate axial and tangential velocities at each circumferential position. The flow angles presented for each radial position are calculated based on these mass averaged axial and tangential velocities. To obtain the overall performance, the radial values of total temperature were mass averaged, and the values of total pressure were energy averaged. At each measuring station the integrated weight flow was computed based on the radial survey data.

The data, measured at the three measuring stations, were translated to the rotor and stator blade leading and trailing edges by the method presented in reference 4.

The weight flow at stall was obtained in the following manner: During operation in the near-stall condition, the collector valve was slowly closed in small increments. At each increment the weight flow was obtained. The weight flow obtained just before stall occurred is called the stall weight flow. The pressure ratio at stall was obtained by extrapolating the total pressure obtained from the survey data to the stall weight flow.

Orifice weight flow, total pressures, static pressures, and temperatures were all corrected to sea-level conditions based on the rotor inlet conditions.

RESULTS AND DISCUSSION

The results from this investigation will be presented in three main sections. The overall performances for the rotor and the stage are presented first. Radial distribu-

tions of several performance parameters are then presented for the rotor and stator. Finally, the blade-element data are presented for both the rotor and stator. The data presented are computer plotted; occasionally, a data point will be omitted because it falls outside the range of the parameters shown in the figure.

All plotted data and some additional performance parameters are presented in tabular form. The overall performance data are presented in table VI. The blade-element data are presented first for the rotor and then for the stator in tables VII and VIII. The definitions and units used for the tabular data are presented in appendix C.

Overall Performance

The overall performance for rotor 11 and for stage 11-4 are presented in figure 7 and 8. In both of these computer plotted figures, data are presented for speeds from 50 to 100 percent of design speed. For the 70, 90, and 100 percent of design speeds data are presented at several weight flows from choke to the near-stall conditions. For the 50, 60, and 80 percent of design speeds, the overall performance is presented for the near-stall condition only. (Design-point values are shown as solid symbols in both figures.) The stall line (dashed line) shown in figure 8 was determined using the method discussed in the section Test Procedure.

The experimental total pressure and total temperature ratios attained by the stage were 1.557 and 1.167, respectively, at the design weight flow of 29.5 kilograms per second. The experimental stage peak efficiency of 0.81 was 5 points less than the design value and occurred at design weight flow. Experimental rotor peak efficiency was also 5 points less than design, indicating that the low stage efficiency could be attributed to the rotor. The maximum measured efficiencies for the rotor and the stage at the lower speeds were slightly higher than the peak efficiency measured at design speed.

Stall margin at design speed was 19 percent based on weight flows and stage total pressure ratios at peak efficiency and at stall.

Blade-Element Performance - Radial Distributions

The radial distribution of selected flow and performance parameters at design speed are shown in figure 9 for the rotor and in figure 10 for the stator. The data shown represents the flow conditions at near stall, peak efficiency, and choke. (Design values are shown by solid symbols.) Flow and performance results at the peak efficiency weight flow of 29.5 kilograms per second are compared with the design values.

Rotor. - The local values of pressure ratio at the measured peak efficiency weight flow were equal to or slightly lower than design values except in the tip region. The temperature rise efficiency was less than design over the entire blade span, with the greatest difference occurring in the damper region. Losses, as evidenced by the total loss parameter and total loss coefficient, were higher than design values over the whole blade span. The dampers located at the 50 percent radial span position appear to have influenced the losses particularly over the 30 to 70 percent portion of the blade span. Deviation angles were as much as 3.5° lower than design values except in a portion of the damper region. Measured D-factor was comparable with the design values.

Stator. - The design suction-surface incidence angles were obtained experimentally except in the region behind the rotor blade dampers. Stator deviation angles were within 2° except at the tip and hub regions. In these regions the deviation angles were as much as 5° higher than the design values. Stator losses, as evidenced by the total loss parameter, were equal to design except in the region of the rotor blade dampers and the tip and hub. Stator blade D-factor was comparable with the design values. Although the effect of the rotor-blade dampers was not considered in the design of the rotor blade and stator blade, the experimental data indicate that the stator design objective was reasonably attained.

Variations with Incidence Angle

The variations of selected blade-element performance parameters are presented in figure 11 for the rotor and in figure 12 for the stator. The data are presented for 60, 80, and 100 percent of design speed at the blade-element locations at 5, 10, 30, 45, 70, 90, and 95 percent of blade span (measured from the tip). (Design values are shown by solid symbols.) These blade-element performance curves are presented primarily for future reference, to be compared with results for other blade shapes. Only a few brief observations are made in this section.

Both the rotor and stator blades were designed for a zero incidence angle at the blade suction-surface leading edge. Except at the hub, measured suction-surface incidence angles corresponding to minimum losses were within $\pm 1^{\circ}$ of the design values for the rotor blade. The minimum losses for the stator could be considered constant over a range of suction-surface incidence angles from about -6° to 2° for most of the blade span. The variation of stator losses with incidence angle as indicated by the total loss parameter or the total loss coefficient remained essentially constant from 60 to 100 percent of design speed.

SUMMARY OF RESULTS

The overall and blade-element performance are presented for a transonic axial-flow compressor stage. The rotor was designed for a tip speed of 424.8 meters per second and a weight flow per unit annulus area of 198.2 kilograms per second per square meter. Design values of weight flow, pressure ratio, and temperature ratio were 29.5 kilograms per second, 1.57 and 1.16, respectively. The investigation yielded the following principal results:

1. At design speed the stage peak efficiency of 0.81 occurred at design weight flow. The stage total pressure ratio was 1.56 and the stage total temperature ratio was 1.17.

2. Stall margin at design speed was 19 percent, based on weight flows and pressure ratio at peak efficiency and at stall.

3. The rotor blade losses were in general higher than design. The blade damper located at 50 percent span from the tip appeared to have considerable effect on these losses. Stator blade losses were equal to design values except in the region behind the rotor dampers and near the end walls.

4. Suction-surface incidence angles corresponding to minimum losses were within $\pm 1^\circ$ of the design values for the rotor blades except at the hub. The minimum losses for the stator could be considered constant over a range of incidence angles from -6° to 2° for most of the blade span.

5. Deviation angles for the rotor were as much as 3.5° less than the design values except in a portion of the damper region. Stator deviation angles exceeded design values by as much as 5° in the tip and hub regions but were close to design over the rest of the blade.

Lewis Research Center,
National Aeronautics and Space Administration,
Cleveland, Ohio, July 11, 1973,
501-24.

APPENDIX A

SYMBOLS

A_{an}	annulus area at rotor leading edge, 0.147 m^2
A_f	frontal area at rotor leading edge, 0.198 m^2
C_p	specific heat at constant pressure, $1004 \text{ J}/(\text{kg})(\text{K})$
c	aerodynamic chord, cm
D	diffusion factor
g	acceleration of gravity, $9.81 \text{ m}/\text{sec}^2$
i_{mc}	mean incidence angle, angle between inlet air direction and line tangent to blade mean camber line at leading edge, deg
i_{ss}	suction-surface incidence angle, angle between inlet air direction and line tangent to blade suction surface at leading edge, deg
J	mechanical equivalent of heat
N	rotative speed, rpm
P	total pressure, N/cm^2
p	static pressure, N/cm^2
r	radius, cm
SM	stall margin
T	total temperature, K
U	wheel speed, m/sec
V	air velocity, m/sec
W	weight flow, kg/sec
Z	axial distance referenced from rotor blade hub leading edge, cm
α_c	cone angle, deg
α_s	slope of streamline, deg
β	air angle, angle between air velocity and axial direction, deg
β'_c	relative meridional air angle based on cone angle, $\arctan(\tan \beta'_m \cos \alpha_c / \cos \alpha_s)$, deg
γ	ratio of specific heats (1.40)

δ	ratio of rotor inlet total pressure to standard pressure of 10.13 N/cm ²
δ°	deviation angle, angle between exit air direction and tangent to blade mean camber line at trailing edge, deg
θ	ratio of rotor inlet total temperature to standard temperature of 288.2 K
η	efficiency
κ_{mc}	angle between the blade mean camber line and the meridional plane, deg
κ_{ss}	angle between the blade suction-surface camber line at the leading edge and the meridional plane, deg
σ	solidity, ratio of chord to spacing
$\bar{\omega}$	total loss coefficient
$\bar{\omega}_p$	profile loss coefficient
$\bar{\omega}_s$	shock loss coefficient

Subscripts:

ad	adiabatic (temperature rise)
id	ideal
LE	blade leading edge
m	meridional direction
mom	momentum-rise
p	polytropic
r	radial direction
ref	reference
TE	blade trailing edge
z	axial direction
θ	tangential direction
1	instrumentation plane upstream of rotor
2	instrumentation plane between rotor and stator
3	instrumentation plane downstream of stator

Superscript:

'	relative to blade
---	-------------------

APPENDIX B

EQUATIONS

Suction surface incidence angle -

$$i_{ss} = (\beta'_c)_{LE} - \kappa_{ss} \quad (B1)$$

Mean incidence angle -

$$i_{mc} = (\beta'_c)_{LE} - (\kappa_{mc})_{LE} \quad (B2)$$

Deviation angle -

$$\delta^0 = (\beta'_c)_{TE} - (\kappa_{mc})_{TE} \quad (B3)$$

Diffusion factor -

$$D = 1 - \frac{V'_{TE}}{V'_{LE}} + \left| \frac{(rV_\theta)_{TE} - (rV_\theta)_{LE}}{(r_{TE} + r_{LE})^\sigma (V'_{LE})} \right| \quad (B4)$$

Total loss coefficient -

$$\bar{\omega} = \frac{(P'_{id})_{TE} - (P')_{TE}}{(P')_{LE} - (p)_{LE}} \quad (B5)$$

Profile loss coefficient -

$$\bar{\omega}_p = \bar{\omega} - \bar{\omega}_s \quad (B6)$$

Total loss parameter -

$$\frac{\bar{\omega} \cos (\beta'_m)_{TE}}{2\sigma} \quad (B7)$$

Profile loss parameter -

$$\frac{\bar{\omega}_p \cos(\beta'_m)_{TE}}{2\sigma} \quad (B8)$$

Adiabatic (temperature-rise) efficiency -

$$\eta_{ad} = \frac{\left(\frac{P_{TE}}{P_{LE}}\right)^{(\gamma-1)/\gamma} - 1}{\frac{T_{TE}}{T_{LE}} - 1} \quad (B9)$$

Momentum-rise efficiency -

$$\eta_{mom} = \frac{\left(\frac{P_{TE}}{P_{LE}}\right)^{(\gamma-1)/\gamma} - 1}{\frac{(UV_\theta)_{TE} - (UV_\theta)_{LE}}{T_{LE} g J C_p}} \quad (B10)$$

Equivalent weight flow -

$$\frac{W\sqrt{\theta}}{\delta} \quad (B11)$$

Equivalent rotative speed -

$$\frac{N}{\sqrt{\theta}} \quad (B12)$$

Weight flow per unit annulus area -

$$\frac{\frac{W\sqrt{\theta}}{\delta}}{A_{an}} \quad (B13)$$

Weight flow per unit frontal area -

$$\frac{\frac{W\sqrt{\theta}}{\delta}}{A_f} \quad (B14)$$

Head-rise coefficient -

$$\frac{gJ C_p T_{LE}}{U_{tip}^2} \left[\left(\frac{P_{TE}}{P_{LE}} \right)^{(\gamma-1)/\gamma} - 1 \right] \quad (B15)$$

Flow coefficient -

$$\left(\frac{V_z}{U_{tip}} \right)_{LE} \quad (B16)$$

Stall margin -

$$SM = \frac{\left[\left(\frac{P_{TE}}{P_{LE}} \right)_{stall} \times \frac{\left(\frac{W\sqrt{\theta}}{\delta} \right)_{ref}}{\left(\frac{W\sqrt{\theta}}{\delta} \right)_{stall}} - 1 \right]}{\left[\left(\frac{P_{TE}}{P_{LE}} \right)_{ref} \right]} \times 100 \quad (B17)$$

Polytropic efficiency -

$$\eta_p = \exp \left[\frac{\left(\frac{P_{TE}}{P_{LE}} \right)^{(\gamma-1)/\gamma}}{\frac{T_{TE}}{T_{LE}}} \right] \quad (B18)$$

APPENDIX C

DEFINITIONS AND UNITS USED IN TABLES

ABS	absolute
AERO CHORD	aerodynamic chord, cm
AREA RATIO	ratio of actual flow area to critical area (where local Mach number is one)
BETAM	meridional air angle, deg
CONE ANGLE	angle between axial direction and conical surface representing blade element, deg
DELTA INC	difference between mean camber blade angle and suction-surface blade angle at leading edge, deg
DEV	deviation angle (defined by eq. (B3)), deg
D-FACT	diffusion factor (defined by eq. (B4))
EFF	adiabatic efficiency (defined by eq. (B9))
IN	inlet (leading edge of blade)
INCIDENCE	incidence angle (suction surface defined by eq. (B1) and mean defined by eq. (B2))
KIC	angle between the blade mean camber line at the leading edge and the meridional plane, deg
KOC	angle between the blade mean camber line at the trailing edge and the meridional plane, deg
KTC	angle between the blade mean camber line at the transition point and the meridional plane, deg
LOSS COEFF	loss coefficient (total defined by eq. (B5) and profile defined by eq. (B6))
LOSS PARAM	loss parameter (total defined by eq. (B7) and profile defined by eq. (B8))
MERID	meridional
MERID VEL R	meridional velocity ratio
OUT	outlet (trailing edge of blade)
PERCENT SPAN	percent of blade span from tip at rotor outlet
PHISS	suction surface camber ahead of assumed shock location, deg

PRESS	pressure, N/cm^2
PROF	profile
RADII	radius, cm
REL	relative to the blade
RI	inlet radius (leading edge of blade), cm
RO	outlet radius (trailing edge of blade), cm
RP	radial position
RPM	equivalent rotative speed, rpm
SETTING ANGLE	angle between aerodynamic chord and meridional plane, deg
SOLIDITY	ratio of aerodynamic chord to blade spacing
SPEED	speed, m/sec
SS	suction surface
STREAMLINE SLOPE	slope of streamline, deg
TANG	tangential
TEMP	temperature, K
TI	thickness of blade at leading edge, cm
TM	thickness of blade at maximum thickness, cm
TO	thickness of blade at trailing edge, cm
TOT	total
TOTAL CAMBER	difference between inlet and outlet blade mean camber lines, deg
VEL	velocity, m/sec
WT FLOW	equivalent weight flow, kg/sec
X FACTOR	ratio of suction-surface camber ahead of assumed shock location of a multiple circular arc blade section to that of a double-circular-arc blade section
ZIC	axial distance to blade leading edge from inlet, cm
ZMC	axial distance to blade maximum thickness point from inlet, cm
ZOC	axial distance to blade trailing edge from inlet, cm
ZTC	axial distance to transition point from inlet, cm

REFERENCES

1. Moore, Royce D.; Urasek, Donald C.; and Kovich, George: Performance of Transonic Fan Stage with Weight Flow per Unit Annulus Area of 178 Kilograms per Second per Square Meter (36.5 (lb/sec)/ft²). NASA TM X-2904, 1973.
2. Urasek, Donald C.; Kovich, George; and Moore, Royce D.: Performance of Transonic Fan Stage with Weight Flow per Unit Annulus Area of 208 Kilograms per Second per Square Meter (42.6 (lb/sec)/ft²). NASA TM X-2903, 1973.
3. Ball, Calvin L.; Janetzke, David C.; and Reid, Lonnie: Performance of a 1380 Foot-Per-Second Tip-Speed Axial-Flow Compressor Rotor with Blade Tip Solidity of 1.5. NASA TM X-2379, 1971.
4. Crouse, James E.; Janetzke, David C.; and Schwirian, Richard E.: A Computer Program for Composing Compressor Blading from Simulated Circular-Arc Elements on Conical Surfaces. NASA TN D-5437, 1969.
5. Keenan, M. J.; and Bartok, J. A.: Experimental Evaluation of Transonic Stators, Data and Performance Report, Multiple-Circular-Arc Stator B. Rep. PWA-3356, Pratt & Whitney Aircraft (NASA CR-54622), 1968.
6. Urasek, Donald C.; and Janetzke, David C.: Performance of Tandem-Bladed Transonic Compressor Rotor with Tip Speed of 1375 Feet-Per-Second. NASA TM X-2484, 1972.
7. Glawe, George E.; Krause, Lloyd N.; and Dudzinski, Thomas J.: A Small Combination Sensing Probe for Measurement of Temperature, Pressure, and Flow Direction. NASA TN D-4816, 1968.

TABLE I. - DESIGN OVERALL PARAMETERS
FOR STAGE 11-4

ROTOR TOTAL PRESSURE RATIO.....	1.601
STAGE TOTAL PRESSURE RATIO.....	1.574
ROTOR TOTAL TEMPERATURE RATIO.....	1.162
STAGE TOTAL TEMPERATURE RATIO.....	1.162
ROTOR ADIABATIC EFFICIENCY.....	0.889
STAGE ADIABATIC EFFICIENCY.....	0.855
ROTOR POLYTROPIC EFFICIENCY.....	0.896
STAGE POLYTROPIC EFFICIENCY.....	0.864
ROTOR HEAD RISE COEFFICIENT.....	0.231
STAGE HEAD RISE COEFFICIENT _i	0.222
FLOW COEFFICIENT.....	0.457
WT FLOW PER UNIT FRONTAL AREA.....	147.822
WT FLOW PER UNIT ANNULUS AREA.....	198.166
WT FLOW.....	29.484
RPM.....	16100.000
TIP SPEED.....	424.815

TABLE II. - DESIGN BLADE-ELEMENT PARAMETERS FOR ROTOR 11

RP	RAD II		ABS BETAM		REL BETAM		TOTAL TEMP		TOTAL PRESS	
	IN	OUT	IN	OUT	IN	OUT	IN	RATIO	IN	RATIO
TIP	25.197	24.816	0.	43.1	67.1	62.6	288.2	1.198	10.13	1.601
1	24.628	24.280	-0.	41.3	66.1	61.7	288.2	1.186	10.13	1.601
2	24.060	23.744	0.	40.0	65.1	60.7	288.2	1.177	10.13	1.601
3	21.741	21.600	0.	39.3	61.5	56.0	288.2	1.163	10.13	1.601
4	19.960	19.992	0.	40.0	59.1	51.5	288.2	1.157	10.13	1.601
5	19.658	19.724	0.	40.2	58.7	50.6	288.2	1.157	10.13	1.601
6	19.356	19.456	0.	40.4	58.2	49.7	288.2	1.156	10.13	1.601
7	19.052	19.188	0.	40.7	57.8	48.7	288.2	1.156	10.13	1.601
8	18.747	18.920	0.	40.9	57.4	47.6	288.2	1.155	10.13	1.601
9	16.871	17.313	0.	42.5	54.9	40.4	288.2	1.153	10.13	1.601
10	14.202	15.169	0.	45.8	51.1	26.0	288.2	1.153	10.13	1.601
11	13.492	14.633	0.	47.1	50.0	21.0	288.2	1.155	10.13	1.601
HJB	12.700	14.097	0.	48.4	48.7	15.4	288.2	1.157	10.13	1.601

RP	ABS VEL		REL VEL		MERID VEL		TANG VEL		WHEEL SPEED	
	IN	OUT	IN	OUT	IN	OUT	IN	OUT	IN	OUT
TIP	179.2	199.9	461.1	317.2	179.2	145.9	0.	136.7	424.8	418.4
1	184.1	199.1	454.2	315.8	184.1	149.7	-0.	131.3	415.2	409.4
2	188.4	199.2	447.3	312.2	188.4	152.7	0.	127.9	405.7	400.3
3	198.8	204.3	417.0	283.2	198.8	158.2	0.	129.3	366.5	364.2
4	201.7	210.0	392.3	258.2	201.7	160.8	0.	135.1	336.5	337.1
5	201.9	211.2	388.1	253.9	201.9	161.2	0.	136.4	331.4	332.6
6	202.0	212.4	383.8	249.7	202.0	161.6	0.	137.8	326.3	328.0
7	202.0	213.6	379.4	245.4	202.0	162.0	0.	139.2	321.2	323.5
8	201.9	215.0	375.0	241.2	201.9	162.5	0.	140.8	316.1	319.0
9	200.0	224.2	347.7	216.9	200.0	165.3	0.	151.5	284.4	291.9
10	192.9	241.9	307.5	187.6	192.9	168.6	0.	173.5	239.4	255.7
11	190.6	248.1	296.8	181.1	190.6	169.0	0.	181.7	227.5	246.7
HJB	188.0	255.2	284.9	175.6	188.0	169.3	0.	191.0	214.1	237.7

RP	ABS MACH NO		REL MACH NO		MERID MACH NO		STREAMLINE SLOPE		MERID PEAK SS	
	IN	OUT	IN	OUT	IN	OUT	IN	OUT	VEL R	MACH NO
TIP	0.542	0.553	1.394	0.878	0.542	0.404	-5.69	-8.84	0.814	1.562
1	0.558	0.554	1.376	0.878	0.558	0.416	-5.12	-7.72	0.813	1.549
2	0.571	0.556	1.357	0.872	0.571	0.426	-4.46	-6.60	0.810	1.539
3	0.605	0.575	1.270	0.797	0.605	0.445	-0.98	-2.24	0.796	1.519
4	0.615	0.594	1.196	0.730	0.615	0.455	2.14	0.87	0.797	1.509
5	0.615	0.597	1.183	0.718	0.615	0.456	2.70	1.39	0.799	1.508
6	0.616	0.601	1.170	0.707	0.616	0.457	3.28	1.92	0.800	1.507
7	0.616	0.605	1.157	0.695	0.616	0.459	3.86	2.44	0.802	1.506
8	0.615	0.609	1.143	0.683	0.615	0.460	4.46	2.97	0.805	1.506
9	0.609	0.638	1.059	0.617	0.609	0.470	8.45	6.33	0.826	1.501
10	0.586	0.693	0.934	0.537	0.586	0.483	15.38	11.44	0.874	1.467
11	0.579	0.712	0.901	0.520	0.579	0.485	17.58	12.87	0.887	1.431
HJB	0.570	0.734	0.864	0.505	0.570	0.487	20.23	14.35	0.901	1.379

RP	PERCENT SPAN	INCIDENCE		DEV	D-FACT	EFF	LOSS COEFF		LOSS PARAM	
		MEAN	SS				TOT	PROF	TOT	PROF
TIP	0.	2.5	-0.0	4.8	0.425	0.728	0.212	0.119	0.038	0.021
1	5.00	2.8	-0.0	4.4	0.413	0.774	0.171	0.085	0.031	0.015
2	10.00	3.0	0.0	4.0	0.407	0.813	0.140	0.058	0.025	0.010
3	30.00	4.1	-0.0	2.9	0.424	0.884	0.088	0.024	0.017	0.004
4	45.00	4.9	0.0	2.7	0.449	0.914	0.069	0.016	0.013	0.003
5	47.50	5.1	0.0	2.7	0.453	0.918	0.067	0.016	0.013	0.003
6	50.00	5.2	0.0	2.7	0.458	0.921	0.065	0.016	0.013	0.003
7	52.50	5.4	0.0	2.8	0.462	0.924	0.063	0.016	0.012	0.003
8	55.00	5.5	-0.0	2.8	0.467	0.927	0.062	0.016	0.012	0.003
9	70.00	6.3	0.0	3.5	0.492	0.942	0.054	0.020	0.011	0.004
10	90.00	7.3	0.0	5.6	0.519	0.938	0.069	0.052	0.014	0.010
11	95.00	7.5	0.0	6.3	0.524	0.929	0.084	0.073	0.017	0.014
HJB	100.00	7.6	-0.1	7.1	0.523	0.917	0.107	0.102	0.020	0.019

TABLE III. - DESIGN BLADE-ELEMENT PARAMETERS FOR STATOR 4

RP	RADII		ABS BETAM		REL BETAM		TOTAL TEMP		TOTAL PRESS	
	IN	OUT	IN	OUT	IN	OUT	IN	RATIO	IN	RATIO
TIP	24.394	24.384	38.3	0.	38.3	0.	345.2	1.000	16.22	0.983
1	23.919	23.908	36.7	-0.	36.7	-0.	341.7	1.000	16.22	0.981
2	23.453	23.459	35.7	0.	35.7	0.	339.1	1.000	16.22	0.982
3	21.557	21.636	35.5	0.	35.5	0.	335.0	1.000	16.22	0.989
4	20.113	20.265	36.3	0.	36.3	0.	333.5	1.000	16.22	0.988
5	19.872	20.038	36.5	0.	36.5	0.	333.3	1.000	16.22	0.987
6	19.630	19.810	36.7	0.	36.7	0.	333.2	1.000	16.22	0.987
7	19.388	19.582	36.9	0.	36.9	0.	333.0	1.000	16.22	0.987
8	19.146	19.355	37.2	0.	37.2	0.	332.9	1.000	16.22	0.986
9	17.692	18.004	38.6	0.	38.6	0.	332.2	1.000	16.22	0.984
10	15.755	16.239	41.6	0.	41.6	0.	332.3	1.000	16.22	0.974
11	15.273	15.805	42.8	0.	42.8	0.	332.8	1.000	16.22	0.966
HUB	14.643	15.240	44.4	-0.	44.4	-0.	333.5	1.000	16.22	0.953

RP	ABS VEL		REL VEL		MERID VEL		TANG VEL		WHEEL SPEED	
	IN	OUT	IN	OUT	IN	OUT	IN	OUT	IN	OUT
TIP	224.5	177.1	224.5	177.1	176.1	177.1	139.3	0.	0.	0.
1	222.9	176.2	222.9	176.2	178.7	176.2	133.3	-0.	0.	0.
2	222.1	176.0	222.1	176.0	180.5	176.0	129.5	0.	0.	0.
3	223.4	179.2	223.4	179.2	181.9	179.2	129.6	0.	0.	0.
4	226.7	179.9	226.7	179.9	182.6	179.9	134.3	0.	0.	0.
5	227.5	180.0	227.5	180.0	182.8	180.0	135.4	0.	0.	0.
6	228.3	180.2	228.3	180.2	183.0	180.2	136.5	0.	0.	0.
7	229.3	180.4	229.3	180.4	183.2	180.4	137.8	0.	0.	0.
8	230.2	180.6	230.2	180.6	183.5	180.6	139.1	0.	0.	0.
9	237.4	182.3	237.4	182.3	185.4	182.3	148.2	0.	0.	0.
10	251.3	182.5	251.3	182.5	187.8	182.5	167.0	0.	0.	0.
11	256.2	181.4	256.2	181.4	188.1	181.4	174.0	0.	0.	0.
HUB	263.6	179.3	263.6	179.3	188.3	179.3	184.4	-0.	0.	0.

RP	ABS MACH NO		REL MACH NO		MERID MACH NO		STREAMLINE SLOPE		MERID PEAK SS	
	IN	OUT	IN	OUT	IN	OUT	IN	OUT	VEL R	MACH NO
TIP	0.626	0.487	0.626	0.487	0.491	0.487	-1.16	-0.06	1.006	0.905
1	0.625	0.487	0.625	0.487	0.501	0.487	-0.70	0.11	0.986	0.884
2	0.625	0.488	0.625	0.488	0.508	0.488	-0.29	0.26	0.975	0.870
3	0.633	0.501	0.633	0.501	0.515	0.501	1.23	0.91	0.985	0.865
4	0.644	0.504	0.644	0.504	0.519	0.504	2.59	1.54	0.985	0.878
5	0.647	0.504	0.647	0.504	0.520	0.504	2.84	1.65	0.985	0.882
6	0.650	0.505	0.650	0.505	0.521	0.505	3.09	1.77	0.985	0.886
7	0.653	0.506	0.653	0.506	0.522	0.506	3.36	1.89	0.984	0.890
8	0.656	0.506	0.656	0.506	0.523	0.506	3.63	2.01	0.984	0.894
9	0.679	0.512	0.679	0.512	0.530	0.512	5.48	2.81	0.983	0.925
10	0.723	0.512	0.723	0.512	0.540	0.512	8.68	4.02	0.972	0.992
11	0.738	0.509	0.738	0.509	0.542	0.509	9.65	4.30	0.964	1.017
HUB	0.761	0.502	0.761	0.502	0.543	0.502	10.99	4.64	0.952	1.055

RP	PERCENT SPAN		INCIDENCE		DEV	D-FACT	EFF	LOSS COEFF		LOSS PARAM	
	SPAN	MEAN	SS	TOT				PROF	TOT	PROF	
TIP	0.	6.4	-0.0	10.7	0.455	0.	0.080	0.080	0.032	0.032	
1	5.00	6.4	0.0	9.7	0.441	0.	0.082	0.082	0.031	0.031	
2	10.00	6.4	-0.0	9.0	0.428	0.	0.079	0.079	0.030	0.030	
3	30.00	6.4	0.0	8.2	0.399	0.	0.047	0.047	0.016	0.016	
4	45.00	6.4	0.0	8.0	0.399	0.	0.051	0.051	0.017	0.017	
5	47.50	6.4	0.0	8.0	0.399	0.	0.052	0.052	0.017	0.017	
6	50.00	6.4	0.0	8.0	0.400	0.	0.053	0.053	0.017	0.017	
7	52.50	6.4	0.0	8.0	0.401	0.	0.054	0.054	0.017	0.017	
8	55.00	6.4	0.0	8.0	0.402	0.	0.055	0.055	0.017	0.017	
9	70.00	6.4	0.0	7.9	0.410	0.	0.060	0.060	0.017	0.017	
10	90.00	6.3	0.0	8.1	0.442	0.	0.088	0.088	0.023	0.023	
11	95.00	6.3	0.0	8.3	0.458	0.	0.111	0.111	0.027	0.027	
HUB	100.00	6.2	-0.0	8.5	0.483	0.	0.146	0.146	0.035	0.035	

TABLE IV. - BLADE GEOMETRY FOR ROTOR 11

RP	PERCENT RADII			BLADE ANGLES			DELTA	CONE
	SPAN	RI	RO	KIC	KTC	KOC	INC	ANGLE
TIP	0.	25.197	24.816	64.37	62.97	57.71	2.53	-10.431
1	5.	24.628	24.280	63.11	61.83	57.26	2.78	-9.182
2	10.	24.060	23.744	61.90	60.58	56.65	3.04	-8.035
3	30.	21.741	21.600	57.36	54.88	53.15	4.13	-3.095
4	45.	19.960	19.992	54.13	50.29	48.79	4.95	0.651
5	48.	19.658	19.724	53.59	49.49	47.87	5.09	1.291
6	50.	19.356	19.456	53.05	48.68	46.91	5.22	1.935
7	53.	19.052	19.188	52.51	47.86	45.89	5.36	2.581
8	55.	18.747	18.920	51.97	47.02	44.82	5.49	3.232
9	70.	16.871	17.313	48.65	42.07	36.74	6.30	7.403
10	90.	14.202	15.169	44.05	34.00	20.19	7.28	13.919
11	95.	13.492	14.633	42.82	31.93	14.48	7.49	15.774
HUB	100.	12.700	14.097	41.44	29.85	8.02	7.69	18.485

RP	BLADE THICKNESSES			AXIAL DIMENSIONS			
	TI	TM	TO	ZIC	ZMC	ZTC	ZOC
TIP	0.051	0.152	0.051	1.046	2.039	2.444	3.116
1	0.051	0.162	0.051	1.002	2.040	2.415	3.156
2	0.051	0.172	0.051	0.955	2.040	2.381	3.198
3	0.051	0.215	0.051	0.761	2.027	2.191	3.363
4	0.051	0.248	0.051	0.621	2.021	2.003	3.502
5	0.051	0.254	0.051	0.598	2.019	1.967	3.527
6	0.051	0.260	0.051	0.574	2.018	1.930	3.553
7	0.051	0.265	0.051	0.550	2.017	1.892	3.579
8	0.051	0.271	0.051	0.526	2.016	1.852	3.606
9	0.051	0.306	0.051	0.377	2.003	1.588	3.774
10	0.051	0.356	0.051	0.147	1.989	1.143	4.050
11	0.051	0.370	0.051	0.079	1.983	1.013	4.116
HUB	0.051	0.385	0.051	0.000	1.972	0.861	4.179

RP	AERO SETTING TOTAL			X			AREA
	CHORD	ANGLE	CAMBER	SOLIDITY	FACTOR	PHISS	RATIO
TIP	4.634	62.67	6.66	1.298	0.704	4.94	1.040
1	4.628	61.53	5.85	1.325	0.747	5.04	1.040
2	4.625	60.33	5.25	1.355	0.799	5.30	1.040
3	4.616	55.20	4.21	1.492	1.011	7.12	1.039
4	4.614	50.86	5.34	1.618	1.110	8.71	1.039
5	4.615	50.06	5.72	1.641	1.122	8.99	1.039
6	4.615	49.24	6.15	1.665	1.132	9.27	1.039
7	4.616	48.39	6.62	1.691	1.142	9.55	1.039
8	4.618	47.52	7.16	1.717	1.151	9.85	1.039
9	4.636	41.66	11.91	1.899	1.165	11.30	1.039
10	4.716	30.45	23.86	2.249	1.242	13.97	1.040
11	4.753	26.85	28.34	2.367	1.256	14.51	1.040
HUB	4.830	22.79	33.41	2.525	1.251	14.85	1.041

TABLE V. - BLADE GEOMETRY FOR STATOR 4

RP	PERCENT			RADII		BLADE ANGLES			DELTA	CONE
	SPAN	RI	RO	KIC	KTC	KOC	INC	ANGLE		
TIP	0.	24.394	24.384	31.97	26.38	-10.67	6.38	-0.151		
1	5.	23.919	23.908	30.32	25.41	-9.67	6.40	-0.160		
2	10.	23.453	23.459	29.26	24.80	-9.00	6.41	0.092		
3	30.	21.557	21.636	29.04	24.96	-8.21	6.41	1.158		
4	45.	20.113	20.265	29.94	25.83	-8.02	6.40	2.248		
5	48.	19.872	20.038	30.14	26.01	-8.01	6.39	2.450		
6	50.	19.630	19.810	30.35	26.20	-7.99	6.39	2.659		
7	53.	19.388	19.582	30.57	26.40	-7.98	6.39	2.874		
8	55.	19.146	19.355	30.81	26.61	-7.97	6.38	3.096		
9	70.	17.692	18.004	32.31	27.97	-7.93	6.36	4.621		
10	90.	15.755	16.239	35.44	30.68	-8.11	6.30	7.232		
11	95.	15.273	15.805	36.61	31.66	-8.25	6.28	7.960		
HUB	100.	14.643	15.240	38.35	33.10	-8.48	6.25	8.954		

RP	BLADE THICKNESSES			AXIAL DIMENSIONS			
	TI	TM	TO	ZIC	ZMC	ZTC	ZOC
TIP	0.051	0.279	0.051	7.085	8.897	8.415	10.935
1	0.051	0.279	0.051	7.068	8.901	8.335	10.935
2	0.051	0.279	0.051	7.056	8.902	8.273	10.933
3	0.051	0.279	0.051	7.047	8.898	8.167	10.928
4	0.051	0.279	0.051	7.052	8.896	8.121	10.926
5	0.051	0.279	0.051	7.053	8.895	8.115	10.925
6	0.051	0.279	0.051	7.055	8.894	8.108	10.925
7	0.051	0.279	0.051	7.056	8.894	8.102	10.924
8	0.051	0.279	0.051	7.057	8.893	8.096	10.924
9	0.051	0.279	0.051	7.066	8.886	8.057	10.919
10	0.051	0.279	0.051	7.095	8.880	8.025	10.916
11	0.051	0.279	0.051	7.106	8.876	8.022	10.914
HUB	0.051	0.279	0.051	7.123	8.871	8.020	10.911

RP	AERO	SETTING	TOTAL	X			AREA
	CHORD	ANGLE	CAMBER	SOLIDITY	FACTOR	PHISS	RATIO
TIP	4.053	15.81	42.63	1.270	0.600	10.33	1.194
1	4.053	14.90	40.00	1.295	0.600	9.41	1.184
2	4.053	14.33	38.27	1.320	0.600	8.77	1.176
3	4.054	14.13	37.26	1.434	0.600	8.05	1.157
4	4.056	14.54	37.96	1.535	0.600	7.92	1.141
5	4.056	14.64	38.14	1.553	0.600	7.92	1.138
6	4.057	14.74	38.34	1.572	0.600	7.91	1.135
7	4.058	14.84	38.55	1.591	0.600	7.91	1.132
8	4.058	14.96	38.78	1.611	0.600	7.91	1.129
9	4.065	15.67	40.24	1.740	0.600	7.92	1.106
10	4.083	17.19	43.55	1.950	0.600	8.18	1.077
11	4.088	17.76	44.86	2.010	0.600	8.35	1.070
HUB	4.098	18.62	46.83	2.095	0.600	8.62	1.061

TABLE VI. - OVERALL PERFORMANCE FOR STAGE 11-4

(a) 100 Percent of design speed

Parameter	Reading number				
	968	969	970	975	978
ROTOR TOTAL PRESSURE RATIO	1.487	1.596	1.650	1.671	1.670
STAGE TOTAL PRESSURE RATIO	1.456	1.557	1.603	1.611	1.605
ROTOR TOTAL TEMPERATURE RATIO	1.147	1.170	1.186	1.193	1.194
STAGE TOTAL TEMPERATURE RATIO	1.143	1.167	1.183	1.193	1.194
ROTOR TEMP. RISE EFFICIENCY	0.818	0.838	0.826	0.818	0.812
STAGE TEMP. RISE EFFICIENCY	0.794	0.809	0.788	0.756	0.746
ROTOR MOMENTUM RISE EFFICIENCY	0.803	0.828	0.832	0.819	0.814
ROTOR HEAD RISE COEFFICIENT	0.194	0.229	0.247	0.255	0.255
STAGE HEAD RISE COEFFICIENT	0.183	0.216	0.232	0.235	0.234
FLOW COEFFICIENT	0.422	0.411	0.386	0.359	0.353
WT FLOW PER UNIT FRONTAL AREA	150.26	147.80	141.09	133.50	131.55
WT FLOW PER UNIT ANNULUS AREA	201.44	198.13	189.13	178.97	176.34
WT FLOW AT ORIFICE	29.97	29.48	28.14	26.63	26.24
WT FLOW AT ROTOR INLET	30.03	29.55	28.22	26.59	26.25
WT FLOW AT ROTOR OUTLET	30.15	29.63	28.34	27.53	27.31
WT FLOW AT STATOR OUTLET	30.21	29.78	28.78	27.80	27.53
ROTATIVE SPEED	16046.7	16122.1	16100.5	16059.4	16042.4
PERCENT OF DESIGN SPEED	99.7	100.1	100.0	99.7	99.6

(b) 90 Percent of design speed

Parameter	Reading number				
	982	983	984	985	986
ROTOR TOTAL PRESSURE RATIO	1.315	1.480	1.423	1.488	1.493
STAGE TOTAL PRESSURE RATIO	1.284	1.451	1.401	1.452	1.439
ROTOR TOTAL TEMPERATURE RATIO	1.099	1.140	1.124	1.148	1.157
STAGE TOTAL TEMPERATURE RATIO	1.098	1.137	1.121	1.146	1.156
ROTOR TEMP. RISE EFFICIENCY	0.820	0.846	0.858	0.872	0.771
STAGE TEMP. RISE EFFICIENCY	0.754	0.817	0.835	0.769	0.700
ROTOR MOMENTUM RISE EFFICIENCY	0.826	0.862	0.870	0.826	0.774
ROTOR HEAD RISE COEFFICIENT	0.161	0.235	0.209	0.239	0.241
STAGE HEAD RISE COEFFICIENT	0.146	0.223	0.200	0.223	0.217
FLOW COEFFICIENT	0.426	0.376	0.410	0.343	0.309
WT FLOW PER UNIT FRONTAL AREA	140.92	127.22	136.57	118.02	107.95
WT FLOW PER UNIT ANNULUS AREA	188.91	170.55	183.08	158.21	144.69
WT FLOW AT ORIFICE	28.11	25.37	27.24	23.54	21.53
WT FLOW AT ROTOR INLET	28.13	25.41	27.25	23.52	21.53
WT FLOW AT ROTOR OUTLET	28.80	26.26	28.02	24.51	22.52
WT FLOW AT STATOR OUTLET	28.93	25.89	27.66	24.35	23.07
ROTATIVE SPEED	14519.9	14471.1	14505.0	14461.7	14480.5
PERCENT OF DESIGN SPEED	90.2	89.9	90.1	89.8	89.9

(c) 80 Percent of design speed

Parameter	Reading number
	987
ROTOR TOTAL PRESSURE RATIO	1.375
STAGE TOTAL PRESSURE RATIO	1.339
ROTOR TOTAL TEMPERATURE RATIO	1.123
STAGE TOTAL TEMPERATURE RATIO	1.123
ROTOR TEMP. RISE EFFICIENCY	0.773
STAGE TEMP. RISE EFFICIENCY	0.709
ROTOR MOMENTUM RISE EFFICIENCY	0.778
ROTOR HEAD RISE COEFFICIENT	0.238
STAGE HEAD RISE COEFFICIENT	0.217
FLOW COEFFICIENT	0.302
WT FLOW PER UNIT FRONTAL AREA	95.70
WT FLOW PER UNIT ANNULUS AREA	128.29
WT FLOW AT ORIFICE	19.09
WT FLOW AT ROTOR INLET	19.07
WT FLOW AT ROTOR OUTLET	19.88
WT FLOW AT STATOR OUTLET	20.22
ROTATIVE SPEED	12900.5
PERCENT OF DESIGN SPEED	80.1

TABLE VI. - Concluded. OVERALL PERFORMANCE FOR STAGE 11-4

(d) 70 Percent of design speed

Parameter	Reading number				
	988	989	990	991	992
ROTOR TOTAL PRESSURE RATIO	1.166	1.216	1.247	1.266	1.277
STAGE TOTAL PRESSURE RATIO	1.154	1.204	1.235	1.250	1.255
ROTOR TOTAL TEMPERATURE RATIO	1.052	1.066	1.077	1.085	1.093
STAGE TOTAL TEMPERATURE RATIO	1.052	1.066	1.075	1.084	1.092
ROTOR TEMP. RISE EFFICIENCY	0.858	0.868	0.849	0.816	0.775
STAGE TEMP. RISE EFFICIENCY	0.800	0.831	0.827	0.782	0.725
ROTOR MOMENTUM RISE EFFICIENCY	0.889	0.897	0.868	0.843	0.787
ROTOR HEAD RISE COEFFICIENT	0.145	0.186	0.209	0.225	0.234
STAGE HEAD RISE COEFFICIENT	0.135	0.176	0.200	0.213	0.216
FLOW COEFFICIENT	0.430	0.399	0.368	0.334	0.301
WT FLOW PER UNIT FRONTAL AREA	115.99	108.90	101.80	95.09	84.80
WT FLOW PER UNIT ANNULUS AREA	155.49	145.99	136.47	124.79	113.68
WT FLOW AT ORIFICE	23.14	21.72	20.30	18.57	16.91
WT FLOW AT ROTOR INLET	23.17	21.74	20.32	18.56	16.90
WT FLOW AT ROTOR OUTLET	23.58	22.39	20.90	19.36	17.42
WT FLOW AT STATOR OUTLET	23.45	21.98	20.55	18.94	17.68
ROTATIVE SPEED	11331.4	11358.2	11368.5	11353.1	11348.3
PERCENT OF DESIGN SPEED	70.4	70.4	70.6	70.5	70.5

(e) 60 Percent of design speed

(f) 50 Percent of design speed

Parameter	Reading number	Parameter	Reading number
	993		994
ROTOR TOTAL PRESSURE RATIO	1.196	ROTOR TOTAL PRESSURE RATIO	1.135
STAGE TOTAL PRESSURE RATIO	1.180	STAGE TOTAL PRESSURE RATIO	1.124
ROTOR TOTAL TEMPERATURE RATIO	1.068	ROTOR TOTAL TEMPERATURE RATIO	1.047
STAGE TOTAL TEMPERATURE RATIO	1.067	STAGE TOTAL TEMPERATURE RATIO	1.046
ROTOR TEMP. RISE EFFICIENCY	0.778	ROTOR TEMP. RISE EFFICIENCY	0.778
STAGE TEMP. RISE EFFICIENCY	0.726	STAGE TEMP. RISE EFFICIENCY	0.732
ROTOR MOMENTUM RISE EFFICIENCY	0.796	ROTOR MOMENTUM RISE EFFICIENCY	0.800
ROTOR HEAD RISE COEFFICIENT	0.236	ROTOR HEAD RISE COEFFICIENT	0.236
STAGE HEAD RISE COEFFICIENT	0.217	STAGE HEAD RISE COEFFICIENT	0.217
FLOW COEFFICIENT	0.293	FLOW COEFFICIENT	0.285
WT FLOW PER UNIT FRONTAL AREA	70.68	WT FLOW PER UNIT FRONTAL AREA	58.04
WT FLOW PER UNIT ANNULUS AREA	94.75	WT FLOW PER UNIT ANNULUS AREA	77.81
WT FLOW AT ORIFICE	14.10	WT FLOW AT ORIFICE	11.58
WT FLOW AT ROTOR INLET	14.09	WT FLOW AT ROTOR INLET	11.57
WT FLOW AT ROTOR OUTLET	14.62	WT FLOW AT ROTOR OUTLET	12.09
WT FLOW AT STATOR OUTLET	14.68	WT FLOW AT STATOR OUTLET	12.05
ROTATIVE SPEED	9630.3	ROTATIVE SPEED	8050.8
PERCENT OF DESIGN SPEED	59.8	PERCENT OF DESIGN SPEED	50.0

TABLE VII. - BLADE-ELEMENT DATA AT BLADE EDGES FOR ROTOR 11

(a) 100 Percent of design speed; reading number 968

RP	RADII		ABS BETAM		REL BETAM		TOTAL TEMP		TOTAL PRESS	
	IN	OUT	IN	OUT	IN	OUT	IN	RATIO	IN	RATIO
1	24.628	24.280	-0.0	34.4	65.5	59.1	288.7	1.168	10.08	1.516
2	24.061	23.744	-0.0	32.9	64.3	58.1	288.6	1.158	10.12	1.509
3	21.740	21.600	-0.0	32.8	61.1	54.2	288.1	1.143	10.13	1.489
4	19.959	19.992	-0.0	38.5	58.4	49.3	287.9	1.149	10.14	1.469
5	19.660	19.723	-0.0	38.8	58.0	50.8	288.4	1.146	10.14	1.426
6	19.355	19.456	-0.0	38.4	57.5	52.2	288.0	1.139	10.14	1.394
7	19.053	19.187	-0.0	38.9	57.1	52.7	287.8	1.136	10.14	1.379
8	18.748	18.920	-0.0	39.0	56.7	50.8	287.8	1.137	10.14	1.393
9	16.871	17.313	-0.0	37.3	53.8	38.9	288.0	1.136	10.14	1.488
10	14.201	15.169	-0.0	40.5	49.8	24.8	288.0	1.142	10.15	1.525
11	13.492	14.633	-0.0	42.8	48.7	19.3	288.0	1.150	10.13	1.543

RP	ABS VEL		REL VEL		MERID VEL		TANG VEL		WHEEL SPEED	
	IN	OUT	IN	OUT	IN	OUT	IN	OUT	IN	OUT
1	189.1	210.2	455.4	337.6	189.1	173.5	-0.1	118.7	414.2	408.4
2	194.4	211.2	448.8	335.3	194.4	177.4	-0.1	114.6	404.5	399.1
3	201.5	212.7	417.6	305.7	201.5	178.7	-0.1	115.3	365.7	363.3
4	206.2	219.0	393.5	263.0	206.2	171.5	-0.1	136.2	335.0	335.6
5	206.9	210.0	390.3	258.7	206.9	163.7	-0.1	131.6	330.9	332.0
6	207.1	200.4	385.8	256.5	207.1	157.1	-0.0	124.4	325.5	327.2
7	207.3	196.0	382.0	251.6	207.3	152.6	-0.1	123.0	320.8	323.0
8	207.0	200.7	377.0	247.1	207.0	156.0	-0.1	126.3	315.0	317.9
9	207.2	232.6	350.6	237.5	207.2	184.9	-0.0	141.1	282.7	290.1
10	201.8	254.3	312.3	213.0	201.8	193.3	-0.1	165.2	238.3	254.5
11	199.0	262.1	301.5	203.7	199.0	192.2	-0.0	178.2	226.4	245.6

RP	ABS MACH NO		REL MACH NO		MERID MACH NO		MERID PEAK SS	
	IN	OUT	IN	OUT	IN	OUT	VEL R	MACH NO
1	0.573	0.591	1.380	0.949	0.573	0.488	0.917	1.532
2	0.590	0.597	1.363	0.947	0.590	0.501	0.913	1.519
3	0.614	0.606	1.273	0.871	0.614	0.509	0.887	1.509
4	0.630	0.624	1.202	0.749	0.630	0.488	0.832	1.491
5	0.631	0.596	1.191	0.735	0.631	0.465	0.791	1.492
6	0.633	0.570	1.179	0.729	0.633	0.446	0.759	1.490
7	0.634	0.557	1.167	0.715	0.634	0.434	0.736	1.490
8	0.633	0.571	1.152	0.703	0.633	0.444	0.753	1.488
9	0.633	0.670	1.071	0.684	0.633	0.532	0.892	1.469
10	0.615	0.736	0.952	0.617	0.615	0.560	0.958	1.450
11	0.606	0.759	0.918	0.590	0.606	0.556	0.966	1.417

RP	PERCENT		INCIDENCE		DEV	D-FACT	EFF	LOSS COEFF		LOSS PARAM	
	SPAN	MEAN	SS	TOT				PROF	TOT	PROF	
1	5.00	2.2	-0.6	1.7	0.356	0.752	0.173	0.089	0.033	0.017	
2	10.00	2.3	-0.8	1.3	0.347	0.790	0.141	0.063	0.028	0.012	
3	30.00	3.8	-0.4	1.0	0.360	0.843	0.107	0.043	0.021	0.008	
4	45.00	4.3	-0.7	0.5	0.439	0.779	0.164	0.114	0.033	0.023	
5	47.50	4.4	-0.7	2.9	0.440	0.729	0.200	0.151	0.038	0.029	
6	50.00	4.5	-0.7	5.3	0.432	0.716	0.203	0.156	0.037	0.029	
7	52.50	4.7	-0.7	6.8	0.437	0.706	0.209	0.163	0.037	0.029	
8	55.00	4.8	-0.7	6.0	0.443	0.726	0.199	0.156	0.037	0.029	
9	70.00	5.2	-1.1	2.1	0.430	0.884	0.095	0.065	0.020	0.013	
10	90.00	5.9	-1.4	4.4	0.440	0.900	0.102	0.085	0.021	0.017	
11	95.00	6.2	-1.3	4.6	0.454	0.879	0.135	0.124	0.027	0.025	

TABLE VII. - Continued. BLADE-ELEMENT DATA AT BLADE EDGES FOR ROTOR 11

(b) 100 Percent of design speed; reading number 969

RP	RAD II		ABS BETAM		REL BETAM		TOTAL TEMP		TOTAL PRESS	
	IN	OUT	IN	OUT	IN	OUT	IN	RATIO	IN	RATIO
1	24.628	24.280	-0.0	41.8	66.0	57.8	288.6	1.213	10.08	1.673
2	24.061	23.744	-0.0	40.3	65.0	57.5	288.6	1.191	10.12	1.652
3	21.740	21.600	-0.0	39.4	61.7	54.3	288.1	1.169	10.13	1.601
4	19.959	19.992	-0.0	42.4	59.1	48.4	288.1	1.171	10.14	1.602
5	19.660	19.723	-0.0	42.8	58.7	48.7	287.9	1.169	10.14	1.574
6	19.355	19.456	-0.0	43.3	58.3	49.2	288.1	1.165	10.14	1.550
7	19.053	19.187	-0.0	44.1	57.9	49.8	287.9	1.162	10.14	1.525
8	18.748	18.920	-0.0	44.5	57.4	49.5	287.9	1.160	10.14	1.515
9	16.871	17.313	-0.0	42.5	54.7	39.1	287.9	1.153	10.14	1.565
10	14.201	15.169	-0.0	44.8	50.9	25.7	287.9	1.151	10.14	1.570
11	13.492	14.633	-0.0	46.7	49.8	18.9	288.0	1.159	10.13	1.599

RP	ABS VEL		REL VEL		MERID VEL		TANG VEL		WHEEL SPEED	
	IN	OUT	IN	OUT	IN	OUT	IN	OUT	IN	OUT
1	184.4	221.2	454.0	309.0	184.4	164.8	-0.1	147.5	414.8	408.9
2	189.5	217.4	448.6	309.0	189.5	165.8	-0.0	140.5	406.6	401.2
3	197.6	213.3	417.1	282.5	197.6	164.8	-0.1	135.4	367.2	364.9
4	201.9	224.4	393.4	249.9	201.9	165.8	-0.1	151.2	337.5	338.1
5	201.5	219.8	388.3	244.4	201.5	161.3	-0.1	149.3	331.9	333.0
6	202.0	215.0	384.3	239.4	202.0	156.5	-0.1	147.4	326.8	328.5
7	201.8	209.4	379.9	233.4	201.8	150.5	-0.0	145.7	321.8	324.1
8	202.4	208.1	375.9	228.5	202.4	148.4	-0.1	145.8	316.7	319.6
9	201.7	229.3	349.0	218.0	201.7	169.2	-0.1	154.8	284.8	292.3
10	194.9	244.9	309.0	192.8	194.9	173.8	-0.1	172.6	239.7	256.0
11	192.0	256.4	297.7	185.8	192.0	175.9	-0.1	186.6	227.4	246.7

RP	ABS MACH NO		REL MACH NO		MERID MACH NO		MERID PEAK SS	
	IN	OUT	IN	OUT	IN	OUT	VEL R	MACH NO
1	0.558	0.611	1.374	0.854	0.558	0.455	0.894	1.545
2	0.574	0.606	1.360	0.861	0.574	0.462	0.875	1.540
3	0.601	0.601	1.269	0.795	0.601	0.464	0.834	1.526
4	0.616	0.633	1.199	0.705	0.616	0.468	0.821	1.514
5	0.614	0.620	1.184	0.690	0.614	0.455	0.800	1.511
6	0.616	0.607	1.171	0.675	0.616	0.442	0.775	1.510
7	0.615	0.591	1.158	0.658	0.615	0.425	0.746	1.510
8	0.617	0.587	1.146	0.645	0.617	0.419	0.733	1.509
9	0.615	0.654	1.064	0.622	0.615	0.483	0.839	1.497
10	0.593	0.704	0.940	0.554	0.593	0.499	0.892	1.467
11	0.583	0.737	0.904	0.534	0.583	0.506	0.916	1.430

RP	PERCENT INCIDENCE		DEV	D-FACT	EFF	LOSS COEFF		LOSS PARAM		
	SPAN	MEAN SS				TOT	PROF	TOT	PROF	
1	5.00	2.7	-0.0	0.4	0.441	0.744	0.216	0.130	0.043	0.026
2	10.00	3.0	-0.1	0.8	0.426	0.807	0.153	0.071	0.030	0.014
3	30.00	4.3	0.2	1.1	0.431	0.854	0.114	0.048	0.022	0.009
4	45.00	5.0	0.1	-0.4	0.484	0.842	0.134	0.080	0.027	0.016
5	47.50	5.2	0.1	0.8	0.488	0.818	0.154	0.103	0.031	0.021
6	50.00	5.3	0.0	2.3	0.493	0.809	0.161	0.111	0.032	0.022
7	52.50	5.4	0.1	4.0	0.499	0.790	0.176	0.128	0.034	0.024
8	55.00	5.5	0.0	4.7	0.506	0.789	0.177	0.131	0.034	0.025
9	70.00	6.1	-0.2	2.3	0.494	0.892	0.099	0.064	0.020	0.013
10	90.00	7.0	-0.3	5.2	0.504	0.911	0.096	0.079	0.019	0.016
11	95.00	7.3	-0.2	4.2	0.514	0.901	0.120	0.109	0.024	0.022

TABLE VII. - Continued. BLADE-ELEMENT DATA AT BLADE EDGES FOR ROTOR 11

(c) 100 Percent of design speed; reading number 970

RP	RADII		ABS BETAM		REL BETAM		TOTAL TEMP		TOTAL PRESS	
	IN	OUT	IN	OUT	IN	OUT	IN	RATIO	IN	RATIO
1	24.628	24.280	-0.0	47.6	67.5	57.6	288.7	1.246	10.08	1.758
2	24.061	23.744	-0.0	44.5	66.5	57.3	288.6	1.217	10.12	1.729
3	21.740	21.600	-0.0	43.7	63.3	54.6	288.0	1.186	10.13	1.660
4	19.959	19.992	-0.0	45.7	60.7	49.4	288.1	1.180	10.14	1.645
5	19.660	19.723	-0.0	45.9	60.4	49.4	288.0	1.178	10.14	1.628
6	19.355	19.456	-0.0	46.8	60.0	49.8	287.9	1.176	10.14	1.605
7	19.053	19.187	-0.0	48.4	59.6	50.2	287.8	1.175	10.15	1.583
8	18.748	18.920	-0.0	48.6	59.2	49.3	288.1	1.174	10.14	1.577
9	16.871	17.313	-0.0	46.0	56.5	39.4	288.0	1.163	10.14	1.606
10	14.201	15.169	-0.0	47.7	52.8	26.9	287.9	1.158	10.15	1.590
11	13.492	14.633	-0.0	49.1	51.9	19.3	288.0	1.164	10.13	1.626

RP	ABS VEL		REL VEL		MERID VEL		TANG VEL		WHEEL SPEED	
	IN	OUT	IN	OUT	IN	OUT	IN	OUT	IN	OUT
1	172.1	227.1	449.6	286.2	172.1	153.2	-0.1	167.7	415.4	409.5
2	176.7	221.2	442.6	291.6	176.7	157.7	-0.1	155.2	405.8	400.4
3	184.9	213.3	410.8	266.3	184.9	154.2	-0.1	147.3	366.7	364.4
4	188.5	220.1	385.7	236.4	188.5	153.9	-0.1	157.4	336.4	337.0
5	188.6	217.5	381.6	232.8	188.6	151.4	-0.1	156.1	331.8	332.8
6	188.8	213.2	377.2	226.2	188.8	146.0	-0.1	155.4	326.5	328.2
7	188.4	209.5	372.3	217.0	188.4	139.0	-0.1	156.8	321.1	323.4
8	188.6	209.9	367.8	212.7	188.6	138.8	-0.1	157.5	315.7	318.6
9	188.5	226.6	341.5	203.6	188.5	157.4	-0.1	163.0	284.7	292.1
10	181.5	236.4	300.4	178.6	181.5	159.3	-0.1	174.8	239.3	255.6
11	178.5	250.3	289.1	173.7	178.5	163.9	-0.1	189.1	227.3	246.5

RP	ABS MACH NO		REL MACH NO		MERID MACH NO		MERID PEAK SS	
	IN	OUT	IN	OUT	IN	OUT	VEL R	MACH NO
1	0.519	0.620	1.355	0.781	0.519	0.418	0.890	1.577
2	0.534	0.610	1.336	0.805	0.534	0.435	0.892	1.566
3	0.560	0.596	1.245	0.744	0.560	0.431	0.834	1.556
4	0.572	0.618	1.170	0.664	0.572	0.432	0.816	1.545
5	0.572	0.610	1.158	0.653	0.572	0.425	0.803	1.547
6	0.573	0.598	1.145	0.635	0.573	0.410	0.773	1.546
7	0.572	0.588	1.130	0.609	0.572	0.390	0.738	1.546
8	0.572	0.589	1.116	0.597	0.572	0.390	0.736	1.545
9	0.572	0.643	1.036	0.577	0.572	0.446	0.835	1.544
10	0.550	0.675	0.910	0.510	0.550	0.455	0.877	1.480
11	0.540	0.716	0.874	0.497	0.540	0.469	0.918	1.442

RP	PERCENT		INCIDENCE		DEV	D-FACT	EFF	LOSS COEFF		LOSS PARAM	
	SPAN		MEAN	SS				TOT	PROF	TOT	PROF
1	5.00		4.2	1.4	0.3	0.503	0.712	0.272	0.182	0.055	0.037
2	10.00		4.4	1.4	0.5	0.470	0.780	0.195	0.111	0.039	0.022
3	30.00		5.9	1.7	1.4	0.472	0.840	0.138	0.070	0.027	0.014
4	45.00		6.6	1.7	0.6	0.513	0.850	0.137	0.081	0.027	0.016
5	47.50		6.8	1.7	1.5	0.515	0.838	0.148	0.094	0.029	0.019
6	50.00		7.0	1.7	2.9	0.524	0.821	0.164	0.111	0.032	0.022
7	52.50		7.1	1.8	4.3	0.542	0.799	0.185	0.135	0.035	0.026
8	55.00		7.2	1.7	4.4	0.547	0.801	0.185	0.137	0.035	0.026
9	70.00		7.9	1.6	2.6	0.531	0.888	0.112	0.073	0.023	0.015
10	90.00		9.0	1.7	6.5	0.539	0.899	0.119	0.103	0.024	0.020
11	95.00		9.3	1.8	4.6	0.543	0.909	0.119	0.109	0.024	0.022

TABLE VII. - Continued. BLADE-ELEMENT DATA AT BLADE EDGES FOR ROTOR 11

(d) 100 Percent of design speed; reading number 975

RP	RADI		ABS BETAM		REL BETAM		TOTAL TEMP		TOTAL PRESS	
	IN	OUT	IN	OUT	IN	OUT	IN	RATIO	IN	RATIO
1	24.628	24.280	-0.0	50.5	69.3	59.2	288.8	1.256	10.07	1.768
2	24.061	23.744	-1.1	48.6	68.4	57.0	288.8	1.234	10.11	1.778
3	21.740	21.600	-1.1	45.5	65.2	54.4	288.1	1.196	10.14	1.692
4	19.959	19.992	-1.0	47.0	62.8	50.2	287.9	1.186	10.15	1.662
5	19.660	19.723	-1.0	47.2	62.4	49.6	287.8	1.184	10.15	1.649
6	19.355	19.456	-1.0	48.9	62.0	50.1	287.8	1.182	10.15	1.625
7	19.053	19.187	-1.0	51.0	61.7	50.1	287.8	1.181	10.15	1.609
8	18.748	18.920	-1.0	51.3	61.3	49.3	287.9	1.182	10.15	1.602
9	16.871	17.313	-1.0	47.0	58.7	40.3	287.9	1.166	10.15	1.611
10	14.201	15.169	-1.0	48.2	55.2	27.1	287.9	1.159	10.15	1.602
11	13.492	14.633	-0.9	48.9	54.6	20.2	288.0	1.162	10.09	1.637

RP	ABS VEL		REL VEL		MERID VEL		TANG VEL		WHEEL SPEED	
	IN	OUT	IN	OUT	IN	OUT	IN	OUT	IN	OUT
1	157.1	222.5	443.6	276.1	157.1	141.4	-0.1	171.8	414.8	408.9
2	161.2	225.9	438.6	274.3	161.1	149.5	-3.1	169.4	404.8	399.5
3	170.3	214.7	406.5	258.8	170.3	150.5	-3.2	153.1	366.0	363.6
4	174.7	217.4	381.5	231.3	174.6	148.2	-3.2	159.0	336.0	336.6
5	174.4	216.5	376.8	227.3	174.3	147.2	-3.2	158.7	330.9	331.9
6	174.4	212.2	371.8	217.8	174.4	139.6	-3.2	159.8	325.2	326.9
7	174.5	210.9	367.5	206.7	174.5	132.7	-3.2	164.0	320.2	322.5
8	174.5	210.9	363.1	202.4	174.5	131.9	-3.2	164.6	315.2	318.1
9	174.1	222.2	335.5	198.7	174.1	151.5	-3.1	162.5	283.7	291.1
10	168.0	234.6	294.0	175.6	167.9	156.4	-2.8	174.9	238.5	254.8
11	162.6	246.9	281.0	173.1	162.6	162.4	-2.6	185.9	226.5	245.6

RP	ABS MACH NO		REL MACH NO		MERID MACH NO		MERID PEAK SS	
	IN	OUT	IN	OUT	IN	OUT	VEL R	MACH NO
1	0.471	0.604	1.331	0.749	0.471	0.384	0.900	1.614
2	0.484	0.619	1.317	0.752	0.484	0.410	0.928	1.615
3	0.514	0.597	1.226	0.720	0.513	0.419	0.884	1.606
4	0.528	0.608	1.152	0.647	0.528	0.415	0.849	1.599
5	0.527	0.606	1.138	0.637	0.527	0.412	0.844	1.601
6	0.527	0.594	1.123	0.609	0.527	0.391	0.801	1.600
7	0.527	0.590	1.110	0.578	0.527	0.371	0.760	1.601
8	0.527	0.590	1.097	0.566	0.527	0.369	0.756	1.604
9	0.526	0.628	1.013	0.562	0.526	0.428	0.870	1.612
10	0.506	0.669	0.886	0.501	0.506	0.446	0.931	1.512
11	0.489	0.706	0.845	0.495	0.489	0.465	0.999	1.474

RP	PERCENT		INCIDENCE		DEV	D-FACT	EFF	LOSS COEFF		LOSS PARAM	
	SPAN	MEAN	SS	SS				TOT	PROF	TOT	PROF
1	5.00	6.0	3.2	1.8	0.523	0.690	0.305	0.211	0.059	0.041	
2	10.00	6.4	3.4	0.3	0.519	0.763	0.226	0.133	0.045	0.027	
3	30.00	7.9	3.7	1.3	0.492	0.827	0.158	0.081	0.031	0.016	
4	45.00	8.6	3.7	1.4	0.525	0.841	0.150	0.086	0.030	0.017	
5	47.50	8.9	3.8	1.8	0.528	0.836	0.157	0.094	0.031	0.019	
6	50.00	9.0	3.8	3.2	0.546	0.819	0.174	0.114	0.033	0.022	
7	52.50	9.2	3.8	4.2	0.573	0.803	0.191	0.133	0.036	0.025	
8	55.00	9.3	3.8	4.5	0.578	0.792	0.205	0.147	0.039	0.028	
9	70.00	10.2	3.9	3.5	0.539	0.877	0.128	0.080	0.026	0.016	
10	90.00	11.3	4.0	6.6	0.541	0.908	0.113	0.096	0.022	0.019	
11	95.00	12.1	4.6	5.5	0.531	0.935	0.088	0.078	0.018	0.015	

TABLE VII. - Continued. BLADE-ELEMENT DATA AT BLADE EDGES FOR ROTOR 11

(e) 100 Percent of design speed; reading number 978

RP	RADI		ABS BETAM		REL BETAM		TOTAL TEMP		TOTAL PRESS	
	IN	OUT	IN	OUT	IN	OUT	IN	RATIO	IN	RATIO
1	24.628	24.280	-1.1	50.7	69.6	59.1	288.8	1.257	10.09	1.770
2	24.061	23.744	-1.1	48.6	68.7	56.9	288.9	1.237	10.10	1.783
3	21.740	21.600	-1.1	45.5	65.6	54.5	288.1	1.196	10.14	1.687
4	19.959	19.992	-1.1	47.3	63.2	50.6	287.9	1.184	10.14	1.651
5	19.660	19.723	-1.0	47.8	62.9	49.9	287.8	1.183	10.14	1.647
6	19.355	19.456	-1.1	48.8	62.4	50.1	287.9	1.182	10.14	1.626
7	19.053	19.187	-1.0	51.6	62.1	50.0	287.9	1.183	10.14	1.611
8	18.748	18.920	-1.0	52.5	61.8	48.7	288.0	1.184	10.15	1.608
9	16.871	17.313	-1.0	47.8	59.3	40.6	287.9	1.168	10.15	1.604
10	14.201	15.169	-1.0	48.2	55.6	26.7	287.9	1.160	10.14	1.609
11	13.492	14.633	-0.9	49.1	54.6	20.1	287.9	1.163	10.13	1.629

RP	ABS VEL		REL VEL		MERID VEL		TANG VEL		WHEEL SPEED	
	IN	OUT	IN	OUT	IN	OUT	IN	OUT	IN	OUT
1	155.5	223.0	445.0	274.8	155.5	141.3	-3.0	172.5	414.0	408.1
2	158.9	226.3	437.5	274.1	158.9	149.8	-3.0	169.6	404.6	399.2
3	167.2	213.9	404.5	258.5	167.1	150.0	-3.1	152.4	365.3	362.9
4	170.8	215.0	379.0	229.9	170.8	145.8	-3.1	158.0	335.2	335.8
5	171.0	215.7	374.8	224.8	170.9	144.9	-3.1	159.7	330.5	331.6
6	171.3	212.1	370.3	217.9	171.3	139.6	-3.2	159.6	325.1	326.8
7	171.1	211.5	365.6	204.5	171.1	131.5	-3.1	165.7	320.0	322.3
8	170.6	213.4	360.6	197.2	170.5	130.1	-3.1	169.2	314.6	317.5
9	170.3	220.8	333.0	195.1	170.2	148.2	-3.0	163.7	283.1	290.5
10	165.3	235.9	292.6	175.9	165.3	157.1	-2.8	176.0	238.7	255.0
11	162.9	247.0	281.3	172.2	162.9	161.7	-2.7	186.6	226.6	245.8

RP	ABS MACH NO		REL MACH NO		MERID MACH NO		MERID PEAK SS	
	IN	OUT	IN	OUT	IN	OUT	VEL R	MACH NO
1	0.466	0.605	1.334	0.745	0.466	0.383	0.909	1.627
2	0.477	0.620	1.313	0.751	0.477	0.410	0.943	1.620
3	0.504	0.595	1.219	0.719	0.504	0.417	0.897	1.612
4	0.515	0.601	1.144	0.643	0.515	0.408	0.853	1.608
5	0.516	0.604	1.131	0.630	0.516	0.406	0.848	1.610
6	0.517	0.593	1.117	0.609	0.517	0.391	0.815	1.610
7	0.516	0.591	1.103	0.572	0.516	0.368	0.769	1.612
8	0.515	0.597	1.088	0.551	0.514	0.364	0.763	1.615
9	0.514	0.624	1.004	0.551	0.514	0.419	0.871	1.628
10	0.498	0.673	0.882	0.501	0.498	0.448	0.951	1.517
11	0.490	0.706	0.847	0.492	0.490	0.462	0.993	1.475

RP	PERCENT SPAN		INCIDENCE MEAN		DEV	D-FACT	EFF	LOSS COEFF		LOSS PARAM	
	SPAN	MEAN	SS	TOT				PROF	TOT	PROF	
1	5.00	6.3	3.5	1.7	0.530	0.689	0.306	0.208	0.059	0.040	
2	10.00	6.7	3.6	0.1	0.518	0.759	0.231	0.138	0.047	0.028	
3	30.00	8.2	4.1	1.4	0.489	0.824	0.162	0.085	0.031	0.017	
4	45.00	9.1	4.1	1.9	0.525	0.837	0.155	0.090	0.030	0.018	
5	47.50	9.3	4.2	2.0	0.533	0.838	0.155	0.091	0.030	0.018	
6	50.00	9.4	4.2	3.2	0.544	0.817	0.177	0.116	0.034	0.022	
7	52.50	9.6	4.3	4.1	0.578	0.796	0.201	0.141	0.038	0.027	
8	55.00	9.8	4.3	3.9	0.593	0.791	0.210	0.152	0.040	0.029	
9	70.00	10.7	4.4	3.8	0.547	0.860	0.148	0.098	0.030	0.020	
10	90.00	11.7	4.5	6.3	0.539	0.910	0.112	0.094	0.022	0.019	
11	95.00	12.0	4.6	5.4	0.535	0.918	0.111	0.100	0.022	0.020	

TABLE VII. - Continued. BLADE-ELEMENT DATA AT BLADE EDGES FOR ROTOR 11

(f) 90 Percent of design speed; reading number 982

RP	RADII		ABS BETAM		REL BETAM		TOTAL TEMP		TOTAL PRESS	
	IN	OUT	IN	OUT	IN	OUT	IN	RATIO	IN	RATIO
1	24.628	24.280	-0.0	23.9	65.6	59.9	288.8	1.103	10.07	1.280
2	24.061	23.744	0.0	23.2	64.5	59.0	288.7	1.096	10.11	1.277
3	21.740	21.600	-0.0	24.5	61.1	54.6	288.2	1.091	10.14	1.290
4	19.959	19.992	-0.0	28.0	58.4	49.1	288.0	1.100	10.14	1.309
5	19.660	19.723	-0.0	28.4	57.9	48.5	288.1	1.101	10.14	1.307
6	19.355	19.456	0.0	29.3	57.5	49.1	287.9	1.098	10.15	1.284
7	19.053	19.187	-0.0	30.1	57.1	50.0	287.9	1.095	10.15	1.258
8	18.748	18.920	-0.0	30.9	56.6	49.6	287.8	1.096	10.14	1.255
9	16.871	17.313	0.	29.9	53.7	38.9	288.0	1.099	10.14	1.351
10	14.201	15.169	0.0	35.0	49.6	25.2	287.8	1.110	10.14	1.396
11	13.492	14.633	-0.0	37.1	48.6	20.8	287.9	1.115	10.13	1.415

RP	ABS VEL		REL VEL		MERID VEL		TANG VEL		WHEEL SPEED	
	IN	OUT	IN	OUT	IN	OUT	IN	OUT	IN	OUT
1	169.8	186.6	411.9	340.2	169.8	170.6	-0.0	75.6	375.2	369.9
2	174.8	188.1	406.1	335.6	174.8	172.9	0.0	74.2	366.6	361.8
3	183.2	194.4	378.6	305.1	183.2	176.9	-0.0	80.6	331.3	329.2
4	187.1	204.3	356.6	275.4	187.1	180.3	-0.0	96.0	303.6	304.1
5	187.7	204.2	353.5	271.4	187.7	179.7	-0.0	97.0	299.5	300.5
6	187.7	197.9	349.3	263.7	187.7	172.6	0.0	96.7	294.5	296.1
7	187.4	190.0	344.6	255.8	187.4	164.4	-0.0	95.3	289.2	291.2
8	187.8	188.8	341.1	250.0	187.8	162.1	-0.0	96.9	284.7	287.4
9	188.0	219.4	317.6	244.3	188.0	190.2	0.	109.4	256.0	262.7
10	183.3	239.8	282.9	217.1	183.3	196.4	0.0	137.7	215.5	230.1
11	180.6	245.2	272.9	209.2	180.6	195.7	-0.0	147.8	204.7	222.0

RP	ABS MACH NO		REL MACH NO		MERID MACH NO		MERID PEAK SS	
	IN	OUT	IN	OUT	IN	OUT	VEL R	MACH NO
1	0.511	0.536	1.240	0.978	0.511	0.490	1.004	1.407
2	0.527	0.543	1.225	0.969	0.527	0.499	0.989	1.397
3	0.555	0.564	1.146	0.885	0.555	0.513	0.966	1.399
4	0.568	0.592	1.082	0.798	0.568	0.523	0.964	1.400
5	0.569	0.592	1.072	0.787	0.569	0.521	0.957	1.404
6	0.570	0.573	1.060	0.764	0.570	0.500	0.920	1.406
7	0.568	0.550	1.045	0.740	0.568	0.476	0.877	1.407
8	0.570	0.546	1.035	0.723	0.570	0.469	0.863	1.411
9	0.570	0.640	0.964	0.713	0.570	0.555	1.012	1.387
10	0.555	0.702	0.857	0.635	0.555	0.575	1.071	1.301
11	0.547	0.717	0.826	0.612	0.547	0.572	1.084	1.271

RP	PERCENT		INCIDENCE		DEV	D-FACT	EFF	LOSS COEFF		LOSS PARAM	
	SPAN		MEAN	SS				TOT	PROF	TOT	PROF
1	5.00		2.3	-0.4	2.6	0.243	0.710	0.148	0.107	0.028	0.020
2	10.00		2.5	-0.6	2.3	0.241	0.755	0.119	0.082	0.023	0.016
3	30.00		3.7	-0.5	1.4	0.265	0.827	0.089	0.060	0.017	0.012
4	45.00		4.2	-0.7	0.3	0.311	0.798	0.121	0.098	0.024	0.020
5	47.50		4.4	-0.7	0.7	0.316	0.786	0.130	0.108	0.026	0.022
6	50.00		4.5	-0.8	2.2	0.328	0.752	0.150	0.129	0.029	0.025
7	52.50		4.6	-0.8	4.1	0.340	0.713	0.171	0.151	0.032	0.029
8	55.00		4.7	-0.8	4.8	0.350	0.699	0.182	0.162	0.034	0.031
9	70.00		5.1	-1.2	2.1	0.323	0.909	0.064	0.053	0.013	0.011
10	90.00		5.7	-1.5	4.8	0.344	0.912	0.082	0.081	0.017	0.016
11	95.00		6.0	-1.5	6.0	0.352	0.908	0.094	0.094	0.019	0.019

TABLE VII. - Continued. BLADE-ELEMENT DATA AT BLADE EDGES FOR ROTOR 11

(g) 90 Percent of design speed; reading number 983

RP	RADII		ABS BETAM		REL BETAM		TOTAL TEMP		TOTAL PRESS	
	IN	OUT	IN	OUT	IN	OUT	IN	RATIO	IN	RATIO
1	24.628	24.280	0.0	34.3	66.4	58.7	288.9	1.147	10.07	1.442
2	24.061	23.744	-0.0	34.5	65.3	57.8	288.9	1.133	10.11	1.433
3	21.740	21.600	-0.0	32.2	61.9	54.4	288.1	1.119	10.14	1.414
4	19.959	19.992	0.0	35.4	59.3	48.9	288.0	1.122	10.15	1.421
5	19.660	19.723	-0.0	35.9	59.0	48.1	288.0	1.122	10.15	1.418
6	19.355	19.456	0.0	35.9	58.5	47.9	287.9	1.121	10.15	1.407
7	19.053	19.187	-0.0	37.1	58.2	47.4	287.9	1.121	10.14	1.400
8	18.748	18.920	-0.0	38.3	57.8	47.5	287.8	1.119	10.14	1.384
9	16.871	17.313	-0.0	36.5	55.1	39.5	287.9	1.114	10.15	1.414
10	14.201	15.169	0.0	40.3	51.2	25.3	287.8	1.120	10.14	1.441
11	13.492	14.633	0.0	41.9	50.2	19.6	287.8	1.124	10.13	1.462

RP	ABS VEL		REL VEL		MERID VEL		TANG VEL		WHEEL SPEED	
	IN	OUT	IN	OUT	IN	OUT	IN	OUT	IN	OUT
1	163.1	192.1	408.2	305.2	163.1	158.7	0.0	108.2	374.2	368.9
2	167.9	192.3	402.0	297.4	167.9	158.5	-0.0	108.8	365.2	360.4
3	176.2	191.4	374.6	278.2	176.2	161.9	-0.0	102.1	330.5	328.4
4	179.6	200.6	352.3	248.8	179.6	163.6	0.0	116.1	303.1	303.6
5	179.6	201.2	348.6	244.1	179.6	163.0	-0.0	118.0	298.7	299.7
6	179.9	199.3	344.9	241.0	179.9	161.4	0.0	116.8	294.2	295.8
7	179.7	198.1	340.8	233.8	179.7	158.1	-0.0	119.4	289.5	291.6
8	179.5	194.7	336.6	226.0	179.5	152.8	-0.0	120.8	284.7	287.3
9	178.9	209.1	312.5	218.0	178.9	168.2	-0.0	124.3	256.2	262.9
10	173.2	228.7	276.6	193.1	173.2	174.5	0.0	147.7	215.7	230.4
11	170.5	237.9	266.4	188.1	170.5	177.2	0.0	158.8	204.7	222.0

RP	ABS MACH NO		REL MACH NO		MERID MACH NO		MERID PEAK SS	
	IN	OUT	IN	OUT	IN	OUT	VEL R	MACH NO
1	0.490	0.542	1.226	0.861	0.490	0.448	0.973	1.422
2	0.505	0.546	1.210	0.844	0.505	0.450	0.944	1.411
3	0.532	0.548	1.132	0.796	0.532	0.463	0.919	1.418
4	0.543	0.575	1.066	0.713	0.543	0.469	0.911	1.425
5	0.543	0.577	1.054	0.700	0.543	0.467	0.908	1.431
6	0.545	0.571	1.044	0.691	0.545	0.463	0.897	1.434
7	0.544	0.568	1.031	0.670	0.544	0.453	0.880	1.439
8	0.543	0.558	1.019	0.647	0.543	0.438	0.851	1.446
9	0.541	0.603	0.945	0.629	0.541	0.485	0.940	1.405
10	0.523	0.663	0.835	0.560	0.523	0.506	1.008	1.314
11	0.515	0.691	0.804	0.546	0.515	0.514	1.039	1.281

RP	PERCENT		INCIDENCE		DEV	D-FACT	EFF	LOSS COEFF		LOSS PARAM	
	SPAN	MEAN	SS	TOT				PROF	TOT	PROF	
1	5.00	3.1	0.4	1.3	0.352	0.750	0.176	0.134	0.035	0.026	
2	10.00	3.3	0.2	1.1	0.359	0.812	0.125	0.087	0.025	0.017	
3	30.00	4.5	0.4	1.2	0.348	0.873	0.084	0.054	0.016	0.011	
4	45.00	5.2	0.3	0.1	0.396	0.866	0.098	0.073	0.020	0.015	
5	47.50	5.4	0.3	0.2	0.403	0.859	0.104	0.081	0.021	0.016	
6	50.00	5.5	0.3	1.0	0.403	0.844	0.116	0.093	0.023	0.019	
7	52.50	5.7	0.3	1.5	0.418	0.833	0.126	0.104	0.025	0.021	
8	55.00	5.8	0.3	2.6	0.434	0.815	0.141	0.119	0.028	0.023	
9	70.00	6.5	0.2	2.7	0.409	0.915	0.070	0.059	0.014	0.012	
10	90.00	7.4	0.1	4.9	0.425	0.916	0.088	0.087	0.018	0.018	
11	95.00	7.6	0.2	4.9	0.425	0.926	0.085	0.085	0.017	0.017	

TABLE VII. - Continued. BLADE-ELEMENT DATA AT BLADE EDGES FOR ROTOR 11

(h) 90 Percent of design speed; reading number 984

RP	RADII		ABS BETAM		REL BETAM		TOTAL TEMP		TOTAL PRESS	
	IN	OUT	IN	OUT	IN	OUT	IN	RATIO	IN	RATIO
1	24.628	24.280	0.0	41.7	68.3	58.4	289.4	1.175	10.07	1.533
2	24.061	23.744	0.0	41.1	67.2	57.0	289.2	1.160	10.11	1.533
3	21.740	21.600	0.0	38.4	63.9	54.6	287.9	1.138	10.14	1.481
4	19.959	19.992	0.0	40.2	61.6	49.4	287.8	1.135	10.14	1.477
5	19.660	19.723	0.0	40.7	61.2	48.9	287.8	1.134	10.15	1.469
6	19.355	19.456	0.0	41.6	60.8	48.6	287.8	1.133	10.14	1.459
7	19.053	19.187	-0.0	43.2	60.4	48.3	287.7	1.134	10.14	1.447
8	18.748	18.920	-0.0	44.7	60.1	48.3	287.7	1.133	10.15	1.434
9	16.871	17.313	0.0	43.2	57.6	41.1	287.8	1.125	10.15	1.434
10	14.201	15.169	0.0	44.7	54.0	25.0	287.8	1.127	10.14	1.473
11	13.492	14.633	-0.0	45.9	53.1	19.5	287.8	1.129	10.13	1.485

RP	ABS VEL		REL VEL		MERID VEL		TANG VEL		WHEEL SPEED	
	IN	OUT	IN	OUT	IN	OUT	IN	OUT	IN	OUT
1	148.7	196.1	401.9	279.0	148.7	146.4	0.0	130.5	373.3	368.1
2	153.3	197.8	395.6	273.9	153.3	149.0	0.0	130.1	364.7	359.9
3	161.5	190.3	367.3	257.2	161.5	149.2	0.0	118.2	329.9	327.8
4	163.7	197.1	343.8	231.2	163.7	150.5	0.0	127.3	302.4	302.9
5	164.0	196.5	340.2	226.6	164.0	148.9	0.0	128.2	298.0	299.0
6	164.0	194.9	336.0	220.3	164.0	145.7	0.0	129.5	293.2	294.7
7	163.5	193.4	331.5	211.7	163.5	141.0	-0.0	132.4	288.3	290.4
8	163.4	191.0	327.6	204.0	163.4	135.8	-0.0	134.3	284.0	286.6
9	162.2	198.6	302.6	192.0	162.2	144.7	0.0	136.0	255.4	262.1
10	156.4	222.1	266.0	174.2	156.4	157.9	0.0	156.2	215.2	229.9
11	153.8	230.1	256.1	170.0	153.8	160.2	-0.0	165.2	204.7	222.0

RP	ABS MACH NO		REL MACH NO		MERID MACH NO		MERID PEAK SS	
	IN	OUT	IN	OUT	IN	OUT	VEL R	MACH NO
1	0.445	0.546	1.202	0.777	0.445	0.408	0.984	1.464
2	0.459	0.555	1.185	0.769	0.459	0.418	0.972	1.456
3	0.486	0.540	1.105	0.729	0.486	0.423	0.924	1.467
4	0.493	0.561	1.035	0.658	0.493	0.428	0.919	1.487
5	0.494	0.559	1.024	0.645	0.494	0.424	0.908	1.492
6	0.494	0.555	1.012	0.627	0.494	0.415	0.888	1.498
7	0.492	0.550	0.998	0.602	0.492	0.401	0.862	1.506
8	0.492	0.543	0.987	0.580	0.492	0.386	0.831	1.500
9	0.488	0.568	0.911	0.549	0.488	0.414	0.892	1.431
10	0.470	0.640	0.799	0.502	0.470	0.455	1.009	1.332
11	0.462	0.664	0.769	0.491	0.462	0.463	1.042	1.300

RP	PERCENT		INCIDENCE		DEV	D-FACT	EFF	LOSS COEFF		LOSS PARAM	
	SPAN	MEAN	SS	TOT				PROF	TOT	PROF	
1	5.00	5.0	2.2	1.0	0.427	0.740	0.216	0.170	0.043	0.034	
2	10.00	5.2	2.1	0.3	0.428	0.813	0.148	0.106	0.030	0.021	
3	30.00	6.5	2.4	1.4	0.407	0.862	0.106	0.072	0.021	0.014	
4	45.00	7.5	2.5	0.6	0.442	0.873	0.105	0.076	0.021	0.015	
5	47.50	7.6	2.5	1.1	0.449	0.867	0.111	0.082	0.022	0.016	
6	50.00	7.7	2.5	1.7	0.460	0.854	0.123	0.095	0.024	0.019	
7	52.50	8.0	2.6	2.4	0.480	0.830	0.146	0.118	0.029	0.023	
8	55.00	8.1	2.7	3.4	0.497	0.812	0.164	0.138	0.032	0.027	
9	70.00	9.0	2.7	4.3	0.486	0.867	0.125	0.114	0.025	0.023	
10	90.00	10.1	2.8	4.6	0.480	0.919	0.096	0.095	0.019	0.019	
11	95.00	10.5	3.0	4.8	0.478	0.926	0.094	0.094	0.019	0.019	

TABLE VII. - Continued. BLADE-ELEMENT DATA AT BLADE EDGES FOR ROTOR 11

(i) 90 Percent of design speed; reading number 985

RP	RADII		ABS BETAM		REL BETAM		TOTAL TEMP		TOTAL PRESS	
	IN	OUT	IN	OUT	IN	OUT	IN	RATIO	IN	RATIO
1	24.628	24.280	-0.0	45.4	70.2	58.6	290.1	1.184	10.07	1.555
2	24.061	23.744	-0.0	43.3	69.1	57.2	289.6	1.169	10.11	1.552
3	21.740	21.600	-0.0	42.1	66.0	55.4	287.9	1.145	10.14	1.484
4	19.959	19.992	0.0	45.9	63.9	51.1	287.7	1.145	10.14	1.469
5	19.660	19.723	-0.0	46.9	63.6	50.5	287.6	1.145	10.15	1.464
6	19.355	19.456	0.0	49.0	63.2	50.5	287.4	1.145	10.15	1.452
7	19.053	19.187	-0.0	50.8	62.8	50.3	287.8	1.146	10.14	1.442
8	18.748	18.920	-0.0	52.4	62.5	49.8	287.5	1.146	10.14	1.434
9	16.871	17.313	0.0	46.9	60.1	40.7	287.6	1.134	10.14	1.446
10	14.201	15.169	-0.0	45.2	56.2	25.4	287.6	1.129	10.15	1.483
11	13.492	14.633	-0.0	46.6	55.3	20.1	287.7	1.130	10.13	1.485

RP	ABS VEL		REL VEL		MERID VEL		TANG VEL		WHEEL SPEED	
	IN	OUT	IN	OUT	IN	OUT	IN	OUT	IN	OUT
1	134.0	197.2	396.4	266.3	134.0	138.6	-0.0	140.4	373.0	367.8
2	139.1	198.1	390.3	266.3	139.1	144.2	-0.0	135.9	364.6	359.8
3	146.4	187.6	360.4	244.8	146.4	139.2	-0.0	125.8	329.3	327.2
4	148.2	191.7	336.9	212.3	148.2	133.3	0.0	137.8	302.5	303.0
5	148.2	191.8	332.9	206.1	148.2	131.1	-0.0	140.1	298.1	299.0
6	148.1	189.9	328.5	195.9	148.1	124.5	0.0	143.4	293.2	294.7
7	148.1	189.2	324.3	187.2	148.1	119.6	-0.0	146.7	288.6	290.6
8	147.4	189.0	319.5	178.6	147.4	115.4	-0.0	149.7	283.4	286.0
9	147.0	198.9	294.7	179.2	147.0	135.9	0.0	145.2	255.4	262.1
10	143.6	219.8	258.4	171.3	143.6	154.8	-0.0	156.1	214.9	229.5
11	141.5	226.4	248.5	165.8	141.5	155.6	-0.0	164.4	204.3	221.5

RP	ABS MACH NO		REL MACH NO		MERID MACH NO		MERID PEAK SS	
	IN	OUT	IN	OUT	IN	OUT	VEL R	MACH NO
1	0.399	0.547	1.179	0.738	0.399	0.384	1.034	1.513
2	0.415	0.553	1.164	0.744	0.415	0.403	1.036	1.504
3	0.439	0.530	1.080	0.691	0.439	0.393	0.950	1.523
4	0.444	0.542	1.010	0.601	0.444	0.377	0.900	1.557
5	0.445	0.543	0.998	0.583	0.445	0.371	0.884	1.565
6	0.444	0.537	0.985	0.554	0.444	0.352	0.841	1.555
7	0.444	0.535	0.972	0.529	0.444	0.338	0.808	1.545
8	0.442	0.534	0.958	0.505	0.442	0.326	0.783	1.536
9	0.441	0.567	0.884	0.511	0.441	0.387	0.924	1.463
10	0.430	0.633	0.774	0.493	0.430	0.445	1.078	1.349
11	0.424	0.653	0.744	0.478	0.424	0.449	1.100	1.314

RP	PERCENT		INCIDENCE		DEV	D-FACT	EFF	LOSS COEFF		LOSS PARAM	
	SPAN	MEAN	SS	TOT				PROF	TOT	PROF	
1	5.00	7.0	4.2	1.3	0.461	0.730	0.238	0.186	0.047	0.037	
2	10.00	7.1	4.0	0.5	0.445	0.792	0.175	0.128	0.035	0.025	
3	30.00	8.6	4.5	2.2	0.437	0.821	0.148	0.108	0.028	0.020	
4	45.00	9.8	4.8	2.3	0.496	0.804	0.176	0.138	0.034	0.027	
5	47.50	10.0	4.9	2.6	0.509	0.794	0.188	0.151	0.036	0.029	
6	50.00	10.2	5.0	3.6	0.535	0.776	0.208	0.174	0.040	0.033	
7	52.50	10.4	5.0	4.4	0.557	0.757	0.230	0.199	0.043	0.038	
8	55.00	10.6	5.1	4.9	0.578	0.744	0.247	0.219	0.047	0.041	
9	70.00	11.5	5.2	3.9	0.523	0.827	0.179	0.167	0.036	0.033	
10	90.00	12.4	5.1	5.0	0.476	0.926	0.092	0.091	0.018	0.018	
11	95.00	12.7	5.2	5.4	0.478	0.922	0.105	0.105	0.021	0.021	

TABLE VII. - Continued. BLADE-ELEMENT DATA AT BLADE EDGES FOR ROTOR 11

(j) 90 Percent of design speed; reading number 986

RP	RADI I		ABS BETAM		REL BETAM		TOTAL TEMP		TOTAL PRESS	
	IN	OUT	IN	OUT	IN	OUT	IN	RATIO	IN	RATIO
1	24.628	24.280	-0.0	52.8	72.5	60.6	290.9	1.196	10.06	1.552
2	24.061	23.744	0.	49.6	71.4	58.2	290.1	1.185	10.11	1.554
3	21.740	21.600	-0.0	49.0	68.4	56.0	287.8	1.161	10.14	1.487
4	19.959	19.992	-0.0	52.6	66.4	51.5	287.4	1.158	10.14	1.473
5	19.660	19.723	-0.0	53.2	66.1	51.1	287.4	1.158	10.15	1.468
6	19.355	19.456	-0.0	54.4	65.7	51.5	287.5	1.156	10.14	1.455
7	19.053	19.187	0.0	55.6	65.4	51.8	287.5	1.155	10.15	1.444
8	18.748	18.920	-0.0	56.6	65.0	51.3	287.4	1.154	10.15	1.438
9	16.871	17.313	0.0	47.9	62.4	40.3	287.4	1.139	10.14	1.460
10	14.201	15.169	0.0	45.6	58.2	25.4	287.4	1.130	10.14	1.494
11	13.492	14.633	-0.0	46.8	57.3	20.0	287.5	1.132	10.14	1.498

RP	ABS VEL		REL VEL		MERID VEL		TANG VEL		WHEEL SPEED	
	IN	OUT	IN	OUT	IN	OUT	IN	OUT	IN	OUT
1	117.3	196.8	391.0	242.1	117.3	118.9	-0.0	156.9	373.0	367.8
2	122.6	199.1	385.0	245.2	122.6	129.1	0.	151.6	364.9	360.1
3	130.7	189.5	354.4	222.4	130.7	124.4	-0.0	143.0	329.4	327.3
4	132.0	194.1	329.7	189.7	132.0	117.9	-0.0	154.1	302.1	302.6
5	132.3	193.7	326.1	184.7	132.3	116.0	-0.0	155.2	298.0	299.0
6	132.3	191.0	321.9	178.7	132.3	111.3	-0.0	155.3	293.5	295.0
7	132.6	188.8	318.3	172.4	132.6	106.5	0.0	155.8	289.4	291.4
8	132.8	188.5	314.0	166.3	132.8	103.9	-0.0	157.3	284.5	287.1
9	134.2	200.7	289.2	176.3	134.2	134.5	0.0	149.0	256.2	262.9
10	133.2	219.6	253.0	170.2	133.2	153.7	0.0	156.8	215.2	229.8
11	131.4	227.2	243.3	165.6	131.4	155.7	-0.0	165.6	204.8	222.1

RP	ABS MACH NO		REL MACH NO		MERID MACH NO		MERID PEAK SS	
	IN	OUT	IN	OUT	IN	OUT	VEL R	MACH NO
1	0.347	0.542	1.157	0.666	0.347	0.327	1.014	1.574
2	0.364	0.552	1.142	0.680	0.364	0.358	1.053	1.567
3	0.390	0.532	1.058	0.624	0.390	0.349	0.952	1.590
4	0.395	0.546	0.985	0.534	0.395	0.332	0.893	1.616
5	0.395	0.545	0.974	0.520	0.395	0.326	0.876	1.609
6	0.395	0.538	0.962	0.503	0.395	0.313	0.841	1.601
7	0.396	0.531	0.951	0.485	0.396	0.300	0.803	1.593
8	0.397	0.531	0.938	0.468	0.397	0.292	0.782	1.582
9	0.401	0.571	0.865	0.502	0.401	0.383	1.002	1.498
10	0.398	0.632	0.756	0.490	0.398	0.442	1.155	1.370
11	0.393	0.655	0.727	0.477	0.393	0.449	1.184	1.334

RP	PERCENT INCIDENCE		DEV	D-FACT	EFF	LOSS COEFF		LOSS PARAM		
	SPAN	MEAN SS				TOT	PROF	TOT	PROF	
1	5.00	9.3	6.5	3.2	0.531	0.684	0.295	0.235	0.055	0.044
2	10.00	9.4	6.4	1.5	0.507	0.726	0.251	0.194	0.049	0.038
3	30.00	11.0	6.8	2.8	0.507	0.744	0.233	0.184	0.044	0.034
4	45.00	12.3	7.3	2.8	0.569	0.739	0.258	0.213	0.050	0.041
5	47.50	12.5	7.4	3.3	0.579	0.735	0.266	0.223	0.051	0.043
6	50.00	12.7	7.5	4.6	0.590	0.724	0.280	0.241	0.052	0.045
7	52.50	12.9	7.5	5.9	0.604	0.716	0.289	0.253	0.053	0.046
8	55.00	13.0	7.6	6.5	0.617	0.711	0.299	0.265	0.054	0.048
9	70.00	13.8	7.5	3.5	0.528	0.819	0.199	0.184	0.040	0.037
10	90.00	14.4	7.1	5.0	0.470	0.935	0.085	0.084	0.017	0.017
11	95.00	14.7	7.2	5.2	0.469	0.929	0.100	0.100	0.020	0.020

TABLE VII. - Continued. BLADE-ELEMENT DATA AT BLADE EDGES FOR ROTOR 11

(k) 80 Percent of design speed; reading number 987

RP	RAD II		ABS BETAM		REL BETAM		TOTAL TEMP		TOTAL PRESS	
	IN	OUT	IN	OUT	IN	OUT	IN	RATIO	IN	RATIO
1	24.628	24.280	0.0	56.5	72.8	62.0	289.8	1.159	10.10	1.407
2	24.061	23.744	-0.0	50.0	71.7	59.6	289.0	1.149	10.13	1.401
3	21.740	21.600	-0.0	49.0	69.0	55.9	287.9	1.127	10.13	1.372
4	19.959	19.992	-0.0	48.9	67.0	50.7	287.8	1.122	10.14	1.368
5	19.660	19.723	-0.0	49.0	66.6	49.8	287.9	1.121	10.14	1.367
6	19.355	19.456	-0.0	50.5	66.2	50.1	287.8	1.120	10.14	1.358
7	19.053	19.187	-0.0	52.3	65.9	50.2	287.9	1.119	10.14	1.350
8	18.748	18.920	-0.0	53.7	65.6	50.0	287.9	1.118	10.14	1.343
9	16.871	17.313	-0.0	47.0	62.9	39.7	287.7	1.110	10.14	1.360
10	14.201	15.169	-0.0	45.1	58.9	25.5	287.7	1.104	10.14	1.383
11	13.492	14.633	-0.0	46.3	57.9	19.9	287.8	1.105	10.13	1.382

RP	ABS VEL		REL VEL		MERID VEL		TANG VEL		WHEEL SPEED	
	IN	OUT	IN	OUT	IN	OUT	IN	OUT	IN	OUT
1	103.0	174.5	347.3	205.5	103.0	96.4	0.0	145.5	331.7	327.0
2	107.5	172.3	342.4	218.8	107.5	110.7	-0.0	132.0	325.1	320.8
3	112.8	169.3	314.5	198.1	112.8	111.1	-0.0	127.7	293.6	291.7
4	114.5	173.4	292.7	179.8	114.5	114.0	-0.0	130.7	269.3	269.8
5	114.8	173.8	289.1	176.8	114.8	114.1	-0.0	131.2	265.4	266.2
6	115.2	171.6	285.9	170.2	115.2	109.1	-0.0	132.4	261.7	263.1
7	115.1	170.1	282.2	162.6	115.1	104.1	-0.0	134.6	257.7	259.5
8	115.2	169.3	278.6	155.8	115.2	100.1	-0.0	136.5	253.6	255.9
9	116.7	180.6	256.3	160.0	116.7	123.2	-0.0	132.1	228.2	234.2
10	115.9	196.1	224.2	153.5	115.9	138.5	-0.0	138.9	191.9	205.0
11	114.3	203.2	215.2	149.3	114.3	140.4	-0.0	147.0	182.3	197.8

RP	ABS MACH NO		REL MACH NO		MERID MACH NO		MERID PEAK SS	
	IN	OUT	IN	OUT	IN	OUT	VEL R	MACH NO
1	0.304	0.486	1.027	0.573	0.304	0.269	0.937	1.502
2	0.319	0.483	1.015	0.613	0.319	0.310	1.030	1.504
3	0.335	0.480	0.935	0.561	0.335	0.315	0.985	1.487
4	0.341	0.493	0.871	0.511	0.341	0.324	0.995	1.445
5	0.341	0.494	0.860	0.503	0.341	0.324	0.994	1.437
6	0.343	0.488	0.851	0.484	0.343	0.310	0.948	1.430
7	0.342	0.484	0.839	0.462	0.342	0.296	0.904	1.422
8	0.343	0.481	0.829	0.443	0.343	0.285	0.869	1.414
9	0.347	0.518	0.763	0.458	0.347	0.353	1.056	1.357
10	0.345	0.566	0.667	0.443	0.345	0.400	1.195	1.223
11	0.340	0.588	0.640	0.432	0.340	0.406	1.229	1.189

RP	PERCENT		INCIDENCE		DEV	D-FACT	EFF	LOSS COEFF		LOSS PARAM	
	SPAN	MEAN	SS	SS				TOT	PROF	TOT	PROF
1	5.00	9.5	6.7	4.7	0.565	0.647	0.321	0.291	0.057	0.051	
2	10.00	9.7	6.6	2.9	0.502	0.681	0.281	0.252	0.052	0.047	
3	30.00	11.6	7.5	2.7	0.506	0.744	0.224	0.205	0.042	0.039	
4	45.00	12.9	7.9	1.9	0.524	0.771	0.216	0.207	0.042	0.040	
5	47.50	13.0	8.0	1.9	0.527	0.773	0.218	0.210	0.043	0.041	
6	50.00	13.2	8.0	3.2	0.544	0.761	0.231	0.224	0.044	0.043	
7	52.50	13.4	8.1	4.3	0.565	0.751	0.244	0.238	0.046	0.045	
8	55.00	13.6	8.1	5.2	0.584	0.743	0.256	0.251	0.048	0.047	
9	70.00	14.3	8.0	2.9	0.513	0.835	0.178	0.177	0.036	0.036	
10	90.00	15.0	7.7	5.1	0.458	0.938	0.080	0.080	0.016	0.016	
11	95.00	15.3	7.9	5.2	0.456	0.927	0.103	0.103	0.021	0.021	

TABLE VII. - Continued. BLADE-ELEMENT DATA AT BLADE EDGES FOR ROTOR 11

(1) 70 Percent of design speed; reading number 988

RP	RADIUS		ABS BETAM		REL BETAM		TOTAL TEMP		TOTAL PRESS	
	IN	OUT	IN	OUT	IN	OUT	IN	RATIO	IN	RATIO
1	24.628	24.280	-0.0	19.8	65.6	60.1	288.6	1.049	10.09	1.131
2	24.061	23.744	-0.0	18.5	64.3	58.6	288.5	1.047	10.13	1.138
3	21.740	21.600	-0.0	17.2	61.1	55.5	288.2	1.044	10.13	1.143
4	19.959	19.992	-0.0	19.4	58.6	51.2	288.1	1.046	10.14	1.152
5	19.660	19.723	-0.0	20.8	58.2	50.2	288.0	1.047	10.14	1.154
6	19.355	19.456	-0.0	22.1	57.8	49.1	287.9	1.050	10.13	1.155
7	19.053	19.187	-0.0	24.7	57.3	48.0	288.0	1.053	10.14	1.153
8	18.748	18.920	-0.0	26.8	56.9	47.3	288.1	1.056	10.14	1.146
9	16.871	17.313	-0.0	25.6	54.1	39.6	288.0	1.055	10.14	1.186
10	14.201	15.169	-0.0	31.5	49.9	25.2	287.9	1.065	10.14	1.226
11	13.492	14.633	-0.0	33.6	48.9	20.6	287.9	1.069	10.13	1.239

RP	ABS VEL		REL VEL		MERID VEL		TANG VEL		WHEEL SPEED	
	IN	OUT	IN	OUT	IN	OUT	IN	OUT	IN	OUT
1	132.4	146.2	320.9	275.5	132.4	137.6	-0.0	49.5	292.3	288.2
2	137.3	150.7	316.7	273.9	137.3	142.9	-0.0	47.9	285.4	281.6
3	142.3	152.2	294.8	256.6	142.3	145.4	-0.0	45.0	258.1	256.4
4	144.8	157.7	277.7	237.4	144.8	148.8	-0.0	52.3	237.0	237.4
5	145.0	158.9	275.1	231.8	145.0	148.5	-0.0	56.5	233.8	234.5
6	144.8	159.8	271.4	226.0	144.8	148.1	-0.0	60.0	229.5	230.7
7	144.9	159.7	268.6	216.8	144.9	145.1	-0.0	66.6	226.1	227.7
8	144.8	157.9	265.2	208.1	144.8	141.0	-0.0	71.1	222.1	224.2
9	144.9	174.4	247.2	204.3	144.9	157.4	-0.0	75.2	200.2	205.5
10	141.7	195.1	220.2	183.8	141.7	166.4	-0.0	101.8	168.5	180.0
11	139.6	200.0	212.3	178.1	139.6	166.7	-0.0	110.6	159.9	173.4

RP	ABS MACH NO		REL MACH NO		MERID MACH NO		MERID PEAK SS	
	IN	OUT	IN	OUT	IN	OUT	VEL R	MACH NO
1	0.395	0.427	0.957	0.804	0.395	0.402	1.039	1.188
2	0.410	0.441	0.946	0.802	0.410	0.418	1.041	1.171
3	0.426	0.446	0.882	0.753	0.426	0.426	1.021	1.164
4	0.434	0.463	0.831	0.697	0.434	0.436	1.027	1.142
5	0.434	0.466	0.824	0.680	0.434	0.436	1.024	1.140
6	0.434	0.468	0.813	0.662	0.434	0.434	1.022	1.132
7	0.434	0.467	0.804	0.634	0.434	0.425	1.001	1.128
8	0.433	0.461	0.794	0.608	0.433	0.412	0.974	1.121
9	0.434	0.512	0.740	0.600	0.434	0.462	1.086	1.076
10	0.424	0.574	0.659	0.541	0.424	0.489	1.174	1.008
11	0.418	0.588	0.635	0.524	0.418	0.490	1.194	0.983

RP	PERCENT SPAN	INCIDENCE		DEV	D-FACT	EFF	LOSS COEFF		LOSS PARAM	
		MEAN	SS				TOT	PROF	TOT	PROF
1	5.00	2.3	-0.4	2.7	0.199	0.732	0.096	0.095	0.018	0.018
2	10.00	2.3	-0.8	1.8	0.191	0.807	0.067	0.067	0.013	0.013
3	30.00	3.7	-0.4	2.3	0.181	0.885	0.042	0.042	0.008	0.008
4	45.00	4.5	-0.5	2.4	0.204	0.892	0.046	0.046	0.009	0.009
5	47.50	4.6	-0.5	2.3	0.220	0.884	0.051	0.051	0.010	0.010
6	50.00	4.7	-0.5	2.2	0.234	0.845	0.072	0.072	0.014	0.014
7	52.50	4.9	-0.5	2.1	0.266	0.779	0.112	0.112	0.022	0.022
8	55.00	5.0	-0.5	2.5	0.294	0.713	0.153	0.153	0.030	0.030
9	70.00	5.5	-0.8	2.8	0.255	0.902	0.059	0.059	0.012	0.012
10	90.00	6.1	-1.2	4.7	0.271	0.919	0.070	0.070	0.014	0.014
11	95.00	6.3	-1.2	5.9	0.276	0.920	0.077	0.077	0.015	0.015

TABLE VII. - Continued. BLADE-ELEMENT DATA AT BLADE EDGES FOR ROTOR 11

(m) 70 Percent of design speed; reading number 989

RP	RADII		ABS BETAM		REL BETAM		TOTAL TEMP		TOTAL PRESS	
	IN	OUT	IN	OUT	IN	OUT	IN	RATIO	IN	RATIO
1	24.628	24.280	-0.0	27.7	67.1	59.4	288.5	1.072	10.09	1.206
2	24.061	23.744	-0.0	27.0	65.9	58.1	288.4	1.067	10.13	1.207
3	21.740	21.600	-0.0	25.8	62.8	55.0	288.1	1.060	10.14	1.202
4	19.959	19.992	-0.0	27.9	60.4	50.8	288.1	1.061	10.14	1.203
5	19.660	19.723	-0.0	29.2	60.1	49.7	288.0	1.061	10.14	1.206
6	19.355	19.456	-0.0	30.4	59.6	48.4	288.1	1.063	10.14	1.208
7	19.053	19.187	-0.0	32.3	59.3	47.3	288.2	1.066	10.14	1.208
8	18.748	18.920	-0.0	34.1	58.9	46.8	288.1	1.068	10.14	1.201
9	16.871	17.313	-0.0	32.2	56.3	39.9	287.9	1.065	10.14	1.219
10	14.201	15.169	-0.0	36.5	52.4	24.8	287.9	1.072	10.14	1.253
11	13.492	14.633	-0.0	38.4	51.5	19.4	288.0	1.076	10.12	1.266

RP	ABS VEL		REL VEL		MERID VEL		TANG VEL		WHEEL SPEED	
	IN	OUT	IN	OUT	IN	OUT	IN	OUT	IN	OUT
1	123.5	146.8	317.1	255.3	123.5	130.0	-0.0	68.2	292.1	288.0
2	127.6	149.7	312.9	252.2	127.6	133.4	-0.0	67.8	285.7	281.9
3	132.5	149.2	290.1	234.0	132.5	134.3	-0.0	64.8	258.1	256.4
4	134.4	152.6	272.1	213.7	134.4	134.9	-0.0	71.3	236.6	237.0
5	134.5	154.4	269.4	208.3	134.5	134.8	-0.0	75.4	233.5	234.2
6	134.4	156.1	266.0	202.9	134.4	134.7	-0.0	79.0	229.5	230.7
7	134.5	157.1	263.2	195.8	134.5	132.8	-0.0	84.0	226.3	227.9
8	134.4	155.7	260.1	188.6	134.4	129.0	-0.0	87.2	222.7	224.8
9	133.8	165.8	240.9	182.9	133.8	140.4	-0.0	88.2	200.2	205.5
10	130.0	186.8	213.1	165.3	130.0	150.1	-0.0	111.2	168.9	180.4
11	127.9	194.1	205.2	161.2	127.9	152.1	-0.0	120.6	160.5	174.1

RP	ABS MACH NO		REL MACH NO		MERID MACH NO		MERID PEAK SS	
	IN	OUT	IN	OUT	IN	OUT	VEL R	MACH NO
1	0.367	0.424	0.944	0.737	0.367	0.375	1.053	1.223
2	0.380	0.434	0.932	0.731	0.380	0.386	1.046	1.211
3	0.395	0.434	0.866	0.680	0.395	0.391	1.014	1.195
4	0.401	0.444	0.813	0.622	0.401	0.393	1.004	1.168
5	0.402	0.450	0.805	0.606	0.402	0.392	1.002	1.165
6	0.401	0.454	0.794	0.590	0.401	0.392	1.002	1.158
7	0.401	0.456	0.786	0.569	0.401	0.386	0.987	1.155
8	0.401	0.452	0.777	0.547	0.401	0.374	0.960	1.150
9	0.400	0.483	0.719	0.533	0.400	0.409	1.049	1.098
10	0.388	0.546	0.636	0.483	0.388	0.439	1.154	1.026
11	0.381	0.567	0.612	0.471	0.381	0.444	1.189	1.001

RP	PERCENT SPAN		INCIDENCE		DEV	D-FACT	EFF	LOSS COEFF		LOSS PARAM	
	SPAN	MEAN	MEAN	SS				TOT	PROF	TOT	PROF
1	5.00	3.8	1.0	2.0	0.276	0.765	0.123	0.121	0.024	0.023	
2	10.00	3.9	0.9	1.3	0.273	0.825	0.087	0.086	0.017	0.017	
3	30.00	5.4	1.3	1.8	0.268	0.898	0.052	0.052	0.010	0.010	
4	45.00	6.3	1.3	2.1	0.296	0.894	0.060	0.060	0.012	0.012	
5	47.50	6.5	1.4	1.8	0.312	0.895	0.061	0.061	0.012	0.012	
6	50.00	6.6	1.4	1.5	0.327	0.876	0.076	0.076	0.015	0.015	
7	52.50	6.8	1.4	1.4	0.351	0.833	0.108	0.108	0.022	0.022	
8	55.00	7.0	1.5	2.0	0.373	0.786	0.144	0.144	0.029	0.029	
9	70.00	7.7	1.4	3.1	0.338	0.896	0.077	0.077	0.015	0.015	
10	90.00	8.5	1.3	4.4	0.344	0.924	0.076	0.076	0.015	0.015	
11	95.00	8.9	1.4	4.7	0.344	0.914	0.097	0.097	0.019	0.019	

TABLE VII. - Continued. BLADE-ELEMENT DATA AT BLADE EDGES FOR ROTOR 11

(n) 70 Percent of design speed; reading number 990

RP	RADI I		ABS BETAM		REL BETAM		TOTAL TEMP		TOTAL PRESS	
	IN	OUT	IN	OUT	IN	OUT	IN	RATIO	IN	RATIO
1	24.628	24.280	-0.0	35.7	68.5	59.6	288.6	1.090	10.11	1.247
2	24.061	23.744	-0.0	34.5	67.6	57.8	288.5	1.082	10.13	1.253
3	21.740	21.600	-0.0	33.2	64.7	55.6	288.2	1.072	10.13	1.235
4	19.959	19.992	-0.0	34.6	62.4	50.8	288.0	1.073	10.13	1.238
5	19.660	19.723	-0.0	35.5	62.1	49.5	288.1	1.074	10.13	1.240
6	19.355	19.456	0.0	36.4	61.7	48.1	288.0	1.075	10.14	1.244
7	19.053	19.187	-0.0	39.1	61.3	47.9	288.0	1.076	10.13	1.236
8	18.748	18.920	-0.0	40.6	61.0	47.5	288.0	1.077	10.13	1.230
9	16.871	17.313	-0.0	37.8	58.5	40.4	287.9	1.072	10.14	1.240
10	14.201	15.169	-0.0	40.4	54.7	24.6	287.9	1.077	10.13	1.273
11	13.492	14.633	-0.0	41.6	53.7	19.3	287.9	1.078	10.12	1.279

RP	ABS VEL		REL VEL		MERID VEL		TANG VEL		WHEEL SPEED	
	IN	OUT	IN	OUT	IN	OUT	IN	OUT	IN	OUT
1	115.1	146.7	314.6	235.3	115.1	119.1	-0.0	85.7	292.8	288.7
2	117.9	150.4	309.5	232.8	117.9	123.9	-0.0	85.3	286.1	282.3
3	122.6	145.3	286.4	215.3	122.6	121.6	-0.0	79.5	258.9	257.2
4	124.1	150.9	268.2	196.7	124.1	124.3	-0.0	85.6	237.7	238.1
5	124.0	152.9	264.6	191.8	124.0	124.6	-0.0	88.7	233.8	234.5
6	124.2	155.3	261.7	187.3	124.2	125.1	0.0	92.1	230.3	231.6
7	124.0	153.4	258.5	177.6	124.0	119.1	-0.0	96.7	226.8	228.4
8	123.8	152.3	255.2	171.1	123.8	115.6	-0.0	99.1	223.2	225.2
9	123.2	160.6	235.8	166.6	123.2	126.9	-0.0	98.4	201.1	206.3
10	119.9	181.5	207.5	152.0	119.9	138.2	-0.0	117.6	169.4	180.9
11	118.2	188.3	199.6	149.1	118.2	140.7	-0.0	125.0	160.8	174.4

RP	ABS MACH NO		REL MACH NO		MERID MACH NO		MERID PEAK SS	
	IN	OUT	IN	OUT	IN	OUT	VEL R	MACH NO
1	0.342	0.430	0.935	0.674	0.342	0.341	1.034	1.260
2	0.350	0.433	0.920	0.669	0.350	0.356	1.051	1.251
3	0.365	0.420	0.853	0.622	0.365	0.351	0.992	1.231
4	0.370	0.436	0.799	0.569	0.370	0.359	1.001	1.203
5	0.369	0.442	0.788	0.555	0.369	0.360	1.004	1.195
6	0.370	0.449	0.780	0.542	0.370	0.362	1.007	1.191
7	0.369	0.443	0.770	0.513	0.369	0.344	0.961	1.185
8	0.369	0.440	0.760	0.494	0.369	0.334	0.934	1.179
9	0.367	0.466	0.703	0.483	0.367	0.368	1.029	1.125
10	0.357	0.528	0.618	0.443	0.357	0.402	1.153	1.044
11	0.352	0.549	0.594	0.435	0.352	0.410	1.190	1.016

RP	PERCENT		INCIDENCE		DEV	D-FACT	EFF	LOSS COEFF		LOSS PARAM	
	SPAN	MEAN	SS	SS				TOT	PROF	TOT	PROF
1	5.00	5.3	2.5	2.2	0.354	0.725	0.177	0.175	0.034	0.033	
2	10.00	5.6	2.5	1.1	0.349	0.807	0.118	0.117	0.023	0.023	
3	30.00	7.3	3.1	2.4	0.341	0.866	0.082	0.082	0.016	0.015	
4	45.00	8.3	3.4	2.0	0.365	0.862	0.095	0.095	0.018	0.018	
5	47.50	8.5	3.4	1.6	0.378	0.860	0.099	0.099	0.020	0.020	
6	50.00	8.7	3.4	1.2	0.390	0.861	0.102	0.102	0.020	0.020	
7	52.50	8.9	3.5	2.0	0.424	0.819	0.137	0.137	0.027	0.027	
8	55.00	9.0	3.6	2.7	0.443	0.793	0.161	0.161	0.032	0.032	
9	70.00	9.9	3.6	3.6	0.405	0.876	0.104	0.104	0.021	0.021	
10	90.00	10.8	3.6	4.2	0.397	0.929	0.080	0.080	0.016	0.016	
11	95.00	11.1	3.6	4.6	0.391	0.928	0.088	0.088	0.017	0.017	

TABLE VII. - Continued. BLADE-ELEMENT DATA AT BLADE EDGES FOR ROTOR 11

(o) 70 Percent of design speed; reading number 991

RP	RADI I		ABS BETAM		REL BETAM		TOTAL TEMP		TOTAL PRESS	
	IN	OUT	IN	OUT	IN	OUT	IN	RATIO	IN	RATIO
1	24.628	24.280	0.0	42.9	70.6	60.9	288.6	1.102	10.11	1.270
2	24.061	23.744	-0.0	40.2	69.5	58.4	288.5	1.096	10.13	1.280
3	21.740	21.600	-0.0	39.0	66.9	55.6	288.1	1.085	10.13	1.262
4	19.959	19.992	0.0	40.3	64.8	50.7	288.0	1.082	10.14	1.261
5	19.660	19.723	-0.0	40.2	64.5	49.8	288.1	1.082	10.13	1.262
6	19.355	19.456	-0.0	41.7	64.2	49.4	288.0	1.083	10.13	1.258
7	19.053	19.187	-0.0	44.8	63.8	49.3	288.0	1.083	10.14	1.251
8	18.748	18.920	-0.0	46.4	63.5	48.7	288.0	1.084	10.13	1.246
9	16.871	17.313	-0.0	43.1	61.1	40.7	288.0	1.079	10.14	1.254
10	14.201	15.169	-0.0	43.0	57.1	24.7	288.0	1.079	10.13	1.282
11	13.492	14.633	-0.0	44.3	56.1	20.2	288.0	1.080	10.13	1.281

RP	ABS VEL		REL VEL		MERID VEL		TANG VEL		WHEEL SPEED	
	IN	OUT	IN	OUT	IN	OUT	IN	OUT	IN	OUT
1	103.3	144.5	310.2	217.5	103.3	105.8	0.0	98.4	292.5	288.4
2	107.3	149.7	305.8	218.5	107.3	114.4	-0.0	96.5	286.4	282.6
3	110.7	145.9	281.6	200.5	110.7	113.4	-0.0	91.8	258.9	257.3
4	111.4	150.5	261.9	181.2	111.4	114.8	0.0	97.3	237.0	237.4
5	111.6	151.5	259.0	179.1	111.6	115.7	-0.0	97.8	233.8	234.5
6	111.3	150.6	255.9	172.9	111.3	112.4	-0.0	100.2	230.3	231.6
7	111.4	149.2	252.6	162.4	111.4	105.8	-0.0	105.1	226.7	228.3
8	111.3	149.1	249.1	155.8	111.3	102.9	-0.0	107.9	222.9	224.9
9	110.9	157.2	229.3	151.3	110.9	114.8	-0.0	107.4	200.7	206.0
10	109.0	176.8	200.8	142.3	109.0	129.3	-0.0	120.6	168.7	180.1
11	107.3	180.6	192.7	137.7	107.3	129.3	-0.0	126.1	160.0	173.5

RP	ABS MACH NO		REL MACH NO		MERID MACH NO		MERID PEAK SS	
	IN	OUT	IN	OUT	IN	OUT	VEL R	MACH NO
1	0.306	0.411	0.919	0.619	0.306	0.301	1.024	1.305
2	0.318	0.427	0.907	0.624	0.318	0.327	1.067	1.293
3	0.329	0.419	0.837	0.576	0.329	0.325	1.024	1.271
4	0.331	0.433	0.778	0.521	0.331	0.330	1.030	1.235
5	0.331	0.436	0.770	0.516	0.331	0.333	1.037	1.230
6	0.331	0.433	0.760	0.498	0.331	0.324	1.010	1.226
7	0.331	0.429	0.751	0.467	0.331	0.304	0.950	1.218
8	0.331	0.429	0.740	0.448	0.331	0.296	0.924	1.210
9	0.330	0.454	0.681	0.437	0.330	0.331	1.034	1.151
10	0.324	0.513	0.596	0.413	0.324	0.375	1.186	1.058
11	0.319	0.525	0.572	0.400	0.319	0.376	1.204	1.027

RP	PERCENT	INCIDENCE		DEV	D-FACT	EFF	LOSS COEFF		LOSS PARAM	
	SPAN	MEAN	SS				TOT	PROF	TOT	PROF
1	5.00	7.3	4.5	3.5	0.418	0.695	0.223	0.220	0.041	0.040
2	10.00	7.4	4.4	1.7	0.401	0.760	0.172	0.170	0.033	0.033
3	30.00	9.5	5.3	2.4	0.397	0.811	0.138	0.137	0.026	0.026
4	45.00	10.7	5.8	1.9	0.423	0.835	0.131	0.131	0.026	0.026
5	47.50	10.9	5.8	1.9	0.424	0.837	0.132	0.132	0.026	0.026
6	50.00	11.2	6.0	2.5	0.442	0.821	0.148	0.148	0.029	0.029
7	52.50	11.4	6.0	3.4	0.481	0.794	0.174	0.174	0.034	0.034
8	55.00	11.5	6.0	3.9	0.501	0.777	0.194	0.194	0.037	0.037
9	70.00	12.5	6.2	3.9	0.465	0.849	0.144	0.144	0.029	0.029
10	90.00	13.3	6.0	4.3	0.429	0.927	0.089	0.089	0.018	0.018
11	95.00	13.6	6.1	5.4	0.429	0.920	0.105	0.105	0.021	0.021

TABLE VII. - Continued. BLADE-ELEMENT DATA AT BLADE EDGES FOR ROTOR 11

(p) .70 Percent of design speed; reading number 992

RP	RADII		ABS BETAM		REL BETAM		TOTAL TEMP		TOTAL PRESS	
	IN	OUT	IN	OUT	IN	OUT	IN	RATIO	IN	RATIO
1	24.628	24.280	-0.0	59.8	72.7	62.5	288.6	1.131	10.11	1.311
2	24.061	23.744	-0.0	52.8	71.8	60.7	288.5	1.119	10.13	1.292
3	21.740	21.600	0.0	44.0	69.0	55.6	288.1	1.092	10.13	1.275
4	19.959	19.992	-0.0	44.7	67.0	50.8	288.0	1.088	10.13	1.273
5	19.660	19.723	0.0	45.2	66.6	50.0	288.1	1.088	10.13	1.272
6	19.355	19.456	0.0	46.5	66.3	49.8	288.1	1.088	10.13	1.267
7	19.053	19.187	-0.0	49.1	65.9	50.1	288.0	1.088	10.14	1.259
8	18.748	18.920	0.0	50.9	65.6	49.6	287.9	1.088	10.13	1.256
9	16.871	17.313	-0.0	47.1	63.1	40.9	288.0	1.083	10.14	1.260
10	14.201	15.169	-0.0	44.7	59.2	25.1	288.0	1.080	10.13	1.288
11	13.492	14.633	0.0	45.7	58.4	20.1	288.0	1.081	10.13	1.289

RP	ABS VEL		REL VEL		MERID VEL		TANG VEL		WHEEL SPEED	
	IN	OUT	IN	OUT	IN	OUT	IN	OUT	IN	OUT
1	91.3	157.9	306.9	171.8	91.3	79.3	-0.0	136.5	293.0	288.8
2	94.1	150.4	300.9	186.0	94.1	90.9	-0.0	119.8	285.8	282.0
3	98.8	147.0	276.2	186.9	98.8	105.7	0.0	102.1	257.9	256.2
4	100.7	150.6	257.5	169.6	100.7	107.1	-0.0	105.8	237.0	237.4
5	100.9	151.1	254.3	165.8	100.9	106.5	0.0	107.1	233.4	234.2
6	101.0	150.2	251.1	160.0	101.0	103.4	0.0	108.9	229.9	231.1
7	101.2	148.2	248.1	151.2	101.2	96.9	-0.0	112.1	226.5	228.1
8	101.2	148.3	244.9	144.4	101.2	93.5	0.0	115.1	223.0	225.0
9	101.5	155.7	224.7	140.1	101.5	106.0	-0.0	114.1	200.5	205.7
10	100.5	174.2	196.5	136.7	100.5	123.9	-0.0	122.5	168.8	180.3
11	98.9	179.4	188.7	133.4	98.9	125.2	0.0	128.4	160.7	174.2

RP	ABS MACH NO		REL MACH NO		MERID MACH NO		MERID PEAK SS	
	IN	OUT	IN	OUT	IN	OUT	VEL R	MACH NO
1	0.270	0.444	0.908	0.483	0.270	0.223	0.869	1.355
2	0.278	0.425	0.891	0.526	0.278	0.257	0.967	1.339
3	0.293	0.421	0.819	0.535	0.293	0.302	1.070	1.304
4	0.299	0.432	0.764	0.487	0.299	0.307	1.064	1.267
5	0.299	0.434	0.754	0.476	0.299	0.306	1.056	1.260
6	0.300	0.431	0.745	0.459	0.300	0.297	1.023	1.253
7	0.300	0.425	0.736	0.434	0.300	0.278	0.958	1.246
8	0.300	0.425	0.726	0.414	0.300	0.268	0.925	1.240
9	0.301	0.449	0.667	0.404	0.301	0.305	1.044	1.173
10	0.298	0.505	0.583	0.396	0.298	0.359	1.232	1.076
11	0.293	0.521	0.559	0.387	0.293	0.364	1.266	1.048

RP	PERCENT SPAN		INCIDENCE		DEV	D-FACT	EFF	LOSS COEFF		LOSS PARAM	
	SPAN	MEAN	SS	SS				TOT	PROF	TOT	PROF
1	5.00	9.4	6.7	5.1	0.607	0.612	0.356	0.350	0.062	0.061	
2	10.00	9.8	6.7	4.0	0.528	0.638	0.315	0.311	0.057	0.056	
3	30.00	11.7	7.5	2.4	0.447	0.781	0.177	0.176	0.033	0.033	
4	45.00	12.9	7.9	2.0	0.468	0.809	0.166	0.166	0.032	0.032	
5	47.50	13.1	8.0	2.2	0.477	0.808	0.170	0.170	0.033	0.033	
6	50.00	13.2	8.0	2.9	0.493	0.797	0.183	0.183	0.035	0.035	
7	52.50	13.4	8.1	4.2	0.525	0.774	0.207	0.207	0.039	0.039	
8	55.00	13.7	8.2	4.8	0.548	0.763	0.223	0.223	0.042	0.042	
9	70.00	14.6	8.3	4.1	0.512	0.823	0.183	0.183	0.036	0.036	
10	90.00	15.4	8.1	4.6	0.447	0.932	0.088	0.088	0.018	0.018	
11	95.00	15.8	8.3	5.4	0.443	0.929	0.099	0.099	0.020	0.020	

TABLE VII. - Continued. BLADE-ELEMENT DATA AT BLADE EDGES FOR ROTOR 11

(q) 60 Percent of design speed; reading number 993

RP	RADII		ABS BETAM		REL BETAM		TOTAL TEMP		TOTAL PRESS	
	IN	OUT	IN	OUT	IN	OUT	IN	RATIO	IN	RATIO
1	24.628	24.280	-0.0	59.2	73.3	61.8	288.6	1.096	10.11	1.223
2	24.061	23.744	-0.0	52.7	72.4	60.4	288.4	1.087	10.13	1.210
3	21.740	21.600	0.0	43.4	69.7	55.9	288.1	1.066	10.13	1.194
4	19.959	19.992	0.0	43.9	67.6	51.0	288.1	1.064	10.13	1.193
5	19.660	19.723	-0.0	44.5	67.3	50.2	288.1	1.063	10.13	1.192
6	19.355	19.456	-0.0	46.4	67.0	49.9	288.1	1.063	10.13	1.188
7	19.053	19.187	-0.0	48.6	66.7	50.0	288.0	1.063	10.13	1.184
8	18.748	18.920	-0.0	50.7	66.3	49.7	288.1	1.063	10.13	1.180
9	16.871	17.313	-0.0	47.7	63.8	40.7	288.0	1.061	10.13	1.184
10	14.201	15.169	-0.0	44.4	60.0	25.7	287.9	1.058	10.13	1.201
11	13.492	14.633	0.0	45.3	59.0	20.1	288.0	1.058	10.13	1.203

RP	ABS VEL		REL VEL		MERID VEL		TANG VEL		WHEEL SPEED	
	IN	OUT	IN	OUT	IN	OUT	IN	OUT	IN	OUT
1	74.3	135.0	259.4	146.5	74.3	69.2	-0.0	116.0	248.6	245.0
2	77.1	128.6	254.8	157.8	77.1	77.9	-0.0	102.4	242.8	239.6
3	81.4	124.0	234.2	160.5	81.4	90.0	0.0	85.3	219.6	218.2
4	85.0	127.5	217.9	146.0	85.0	91.9	0.0	88.3	201.4	201.7
5	83.1	127.7	215.1	142.4	83.1	91.1	-0.0	89.6	198.4	199.0
6	82.8	126.8	211.6	135.8	82.8	87.4	-0.0	91.8	194.7	195.7
7	82.9	125.8	209.3	129.6	82.9	83.3	-0.0	94.3	192.2	193.6
8	83.1	125.3	206.4	122.8	83.1	79.3	-0.0	97.0	189.0	190.7
9	83.5	132.3	189.4	117.6	83.5	89.1	-0.0	97.8	170.0	174.5
10	82.8	146.7	165.5	116.4	82.8	104.9	-0.0	102.6	143.3	153.0
11	81.7	152.2	158.6	114.0	81.7	107.0	0.0	108.2	136.0	147.4

RP	ABS MACH NO		REL MACH NO		MERID MACH NO		MERID PEAK SS	
	IN	OUT	IN	OUT	IN	OUT	VEL R	MACH NO
1	0.219	0.384	0.765	0.417	0.219	0.197	0.930	1.160
2	0.228	0.367	0.752	0.451	0.228	0.222	1.010	1.147
3	0.241	0.358	0.692	0.463	0.241	0.260	1.107	1.117
4	0.246	0.368	0.644	0.422	0.246	0.265	1.107	1.082
5	0.246	0.369	0.636	0.411	0.246	0.263	1.096	1.077
6	0.245	0.366	0.626	0.392	0.245	0.253	1.057	1.067
7	0.245	0.363	0.619	0.374	0.245	0.240	1.004	1.064
8	0.246	0.362	0.610	0.354	0.246	0.229	0.954	1.056
9	0.247	0.383	0.560	0.341	0.247	0.258	1.068	0.999
10	0.245	0.427	0.489	0.339	0.245	0.305	1.267	0.916
11	0.242	0.443	0.469	0.332	0.242	0.312	1.310	0.889

RP	PERCENT		INCIDENCE		DEV	D-FACT	EFF	LOSS COEFF		LOSS PARAM	
	SPAN		MEAN	SS				TOT	PROF	TOT	PROF
1	5.00		10.1	7.3	4.5	0.603	0.620	0.343	0.343	0.061	0.061
2	10.00		10.4	7.3	3.7	0.528	0.644	0.304	0.304	0.055	0.055
3	30.00		12.3	8.2	2.7	0.436	0.787	0.165	0.165	0.031	0.031
4	45.00		13.5	8.5	2.2	0.455	0.812	0.160	0.160	0.031	0.031
5	47.50		13.7	8.6	2.4	0.465	0.812	0.163	0.163	0.032	0.032
6	50.00		13.9	8.7	3.0	0.489	0.798	0.179	0.179	0.035	0.035
7	52.50		14.2	8.8	4.1	0.515	0.782	0.196	0.196	0.037	0.037
8	55.00		14.3	8.8	4.9	0.543	0.765	0.217	0.217	0.041	0.041
9	70.00		15.3	9.0	3.9	0.517	0.819	0.188	0.188	0.038	0.038
10	90.00		16.1	8.8	5.3	0.439	0.934	0.084	0.084	0.017	0.017
11	95.00		16.4	8.9	5.4	0.431	0.932	0.095	0.095	0.019	0.019

TABLE VII. - Concluded. BLADE-ELEMENT DATA AT BLADE EDGES FOR ROTOR 11

(r) 50 Percent of design speed; reading number 994

RP	RADI I		ABS BETAM		REL BETAM		TOTAL TEMP		TOTAL PRESS	
	IN	OUT	IN	OUT	IN	OUT	IN	RATIO	IN	RATIO
1	24.628	24.280	-0.0	58.2	73.8	61.4	288.5	1.067	10.12	1.154
2	24.061	23.744	0.0	52.9	72.7	60.5	288.4	1.061	10.13	1.143
3	21.740	21.600	0.0	42.5	70.2	55.8	288.2	1.046	10.13	1.132
4	19.959	19.992	-0.0	44.4	68.2	51.1	288.0	1.044	10.13	1.132
5	19.660	19.723	0.0	44.9	67.8	50.4	288.0	1.044	10.13	1.131
6	19.355	19.456	0.0	46.6	67.5	50.0	288.0	1.044	10.13	1.130
7	19.053	19.187	-0.0	49.1	67.2	50.1	288.1	1.044	10.13	1.127
8	18.748	18.920	-0.0	50.8	66.8	49.9	288.0	1.044	10.13	1.124
9	16.871	17.313	0.0	47.6	64.4	40.6	288.0	1.042	10.13	1.127
10	14.201	15.169	0.0	44.3	60.6	25.7	288.0	1.040	10.13	1.138
11	13.492	14.633	0.0	45.4	59.7	20.8	287.9	1.040	10.13	1.138

RP	ABS VEL		REL VEL		MERID VEL		TANG VEL		WHEEL SPEED	
	IN	OUT	IN	OUT	IN	OUT	IN	OUT	IN	OUT
1	60.3	113.0	216.4	124.0	60.3	59.5	-0.0	96.1	207.8	204.9
2	63.0	107.3	212.3	131.6	63.0	64.7	0.0	85.5	202.8	200.1
3	66.0	103.2	194.6	135.6	66.0	76.2	0.0	69.7	183.1	181.9
4	67.4	106.2	181.1	120.9	67.4	75.9	-0.0	74.3	168.1	168.4
5	67.5	106.4	179.0	118.4	67.5	75.5	0.0	75.1	165.8	166.3
6	67.6	106.2	176.6	113.5	67.6	73.0	0.0	77.1	163.2	164.0
7	67.9	105.4	174.8	107.7	67.9	69.1	-0.0	79.6	161.1	162.2
8	67.6	104.5	171.9	102.7	67.6	66.1	-0.0	81.0	158.1	159.5
9	67.9	110.7	157.3	98.2	67.9	74.6	0.0	81.8	141.9	145.6
10	67.6	122.8	137.7	97.6	67.6	88.0	0.0	85.7	119.9	128.1
11	66.4	125.9	131.6	94.5	66.4	88.4	0.0	89.6	113.6	123.2

RP	ABS MACH NO		REL MACH NO		MERID MACH NO		MERID PEAK SS	
	IN	OUT	IN	OUT	IN	OUT	VEL R	MACH NO
1	0.178	0.325	0.638	0.356	0.178	0.171	0.986	0.977
2	0.186	0.309	0.626	0.379	0.186	0.186	1.027	0.962
3	0.195	0.299	0.574	0.393	0.195	0.221	1.154	0.936
4	0.199	0.308	0.534	0.351	0.199	0.221	1.127	0.908
5	0.199	0.309	0.528	0.344	0.199	0.219	1.118	0.904
6	0.199	0.308	0.521	0.330	0.199	0.212	1.081	0.899
7	0.200	0.306	0.516	0.312	0.200	0.201	1.018	0.895
8	0.200	0.303	0.507	0.298	0.200	0.192	0.978	0.888
9	0.200	0.322	0.464	0.286	0.200	0.217	1.098	0.837
10	0.200	0.358	0.406	0.285	0.200	0.257	1.301	0.769
11	0.196	0.368	0.388	0.276	0.196	0.258	1.331	0.746

RP	PERCENT		INCIDENCE		DEV	D-FACT	EFF	LOSS COEFF		LOSS PARAM	
	SPAN	MEAN	SS	TOT				PROF	TOT	PROF	
1	5.00	10.6	7.8	4.0	0.593	0.622	0.336	0.336	0.061	0.061	
2	10.00	10.7	7.7	3.8	0.528	0.644	0.297	0.297	0.054	0.054	
3	30.00	12.8	8.7	2.7	0.423	0.786	0.162	0.162	0.030	0.030	
4	45.00	14.0	9.1	2.3	0.459	0.816	0.153	0.153	0.030	0.030	
5	47.50	14.3	9.2	2.5	0.467	0.816	0.155	0.155	0.030	0.030	
6	50.00	14.5	9.3	3.0	0.489	0.807	0.167	0.167	0.032	0.032	
7	52.50	14.7	9.3	4.2	0.519	0.785	0.191	0.191	0.036	0.036	
8	55.00	14.9	9.4	5.1	0.541	0.764	0.215	0.215	0.040	0.040	
9	70.00	15.8	9.5	3.8	0.514	0.819	0.197	0.187	0.037	0.037	
10	90.00	16.7	9.4	5.3	0.434	0.935	0.083	0.083	0.017	0.017	
11	95.00	17.1	9.6	6.1	0.431	0.928	0.100	0.100	0.020	0.020	

TABLE VIII. - BLADE-ELEMENT DATA AT BLADE EDGES FOR STATOR 4

(a) 100 Percent of design speed; reading number 968

RP	RADI I		ABS BETAM		REL BETAM		TOTAL TEMP		TOTAL PRESS	
	IN	OUT	IN	OUT	IN	OUT	IN	RATIO	IN	RATIO
1	23.919	23.909	29.7	3.4	29.7	3.4	337.1	0.998	15.28	0.961
2	23.452	23.459	28.4	2.5	28.4	2.5	334.2	0.998	15.28	0.984
3	21.557	21.636	29.0	-0.6	29.0	-0.6	329.3	0.999	15.09	0.987
4	20.114	20.267	34.6	1.2	34.6	1.2	330.9	0.992	14.90	0.976
5	19.873	20.038	35.1	0.6	35.1	0.6	330.6	0.992	14.46	0.996
6	19.629	19.809	34.8	-1.3	34.8	-1.3	328.0	0.997	14.13	1.002
7	19.388	19.583	35.3	-2.0	35.3	-2.0	327.0	0.996	13.98	1.009
8	19.147	19.355	35.4	-2.1	35.4	-2.1	327.2	0.996	14.12	0.998
9	17.691	18.004	33.3	-0.5	33.3	-0.5	327.2	0.997	15.09	0.980
10	15.756	16.238	36.0	-0.4	36.0	-0.4	329.0	0.995	15.47	0.973
11	15.273	15.806	38.2	1.7	38.2	1.7	331.2	0.996	15.63	0.943

RP	ABS VEL		REL VEL		MERID VEL		TANG VEL		WHEEL SPEED	
	IN	OUT	IN	OUT	IN	OUT	IN	OUT	IN	OUT
1	243.4	196.6	243.4	196.6	211.5	196.3	120.5	11.5	0.	0.
2	243.7	205.7	243.7	205.7	214.3	205.5	116.1	8.8	0.	0.
3	238.6	203.5	238.6	203.5	208.7	203.5	115.5	-2.2	0.	0.
4	238.3	196.6	238.3	196.6	196.1	196.5	135.4	4.1	0.	0.
5	227.2	192.4	227.2	192.4	185.9	192.4	130.6	2.0	0.	0.
6	216.2	185.0	216.2	185.0	177.6	185.0	123.3	-4.4	0.	0.
7	210.6	183.1	210.6	183.1	171.9	183.0	121.7	-6.5	0.	0.
8	215.6	182.9	215.6	182.9	175.7	182.7	124.8	-6.6	0.	0.
9	251.5	209.1	251.5	209.1	210.3	209.1	138.1	-1.8	0.	0.
10	270.8	228.7	270.8	228.7	219.2	228.7	159.0	-1.5	0.	0.
11	276.2	223.8	276.2	223.8	217.1	223.7	170.7	6.6	0.	0.

RP	ABS MACH NO		REL MACH NO		MERID MACH NO		MERID PEAK SS	
	IN	OUT	IN	OUT	IN	OUT	VEL R	MACH NO
1	0.692	0.551	0.692	0.551	0.601	0.550	0.928	0.796
2	0.697	0.580	0.697	0.580	0.613	0.580	0.959	0.773
3	0.686	0.578	0.686	0.578	0.600	0.578	0.975	0.763
4	0.683	0.558	0.683	0.558	0.562	0.558	1.002	0.889
5	0.649	0.546	0.649	0.546	0.531	0.546	1.035	0.851
6	0.618	0.524	0.618	0.524	0.507	0.524	1.042	0.799
7	0.602	0.520	0.602	0.520	0.491	0.519	1.065	0.784
8	0.617	0.519	0.617	0.519	0.503	0.519	1.040	0.800
9	0.730	0.598	0.730	0.598	0.610	0.598	0.994	0.845
10	0.790	0.657	0.790	0.657	0.639	0.657	1.043	0.913
11	0.805	0.639	0.805	0.639	0.632	0.639	1.030	0.972

RP	PERCENT INCIDENCE		DEV	D-FACT	EFF	LOSS COEFF		LOSS PARAM		
	SPAN	MEAN SS				TOT	PROF	TOT	PROF	
1	5.00	-0.6	-7.0	13.0	0.365	0.	0.142	0.142	0.055	0.055
2	10.00	-0.8	-7.2	11.5	0.323	0.	0.059	0.059	0.022	0.022
3	30.00	-0.1	-6.5	7.6	0.319	0.	0.048	0.048	0.017	0.017
4	45.00	4.7	-1.7	9.2	0.354	0.	0.089	0.089	0.029	0.029
5	47.50	4.9	-1.4	8.6	0.335	0.	0.018	0.018	0.006	0.006
6	50.00	4.4	-1.9	6.6	0.331	0.	-0.011	-0.011	-0.003	-0.003
7	52.50	4.7	-1.6	5.9	0.321	0.	-0.043	-0.043	-0.014	-0.014
8	55.00	4.6	-1.8	5.9	0.340	0.	0.010	0.010	0.003	0.003
9	70.00	1.0	-5.3	7.4	0.327	0.	0.068	0.068	0.019	0.019
10	90.00	0.6	-5.7	7.7	0.305	0.	0.080	0.080	0.020	0.020
11	95.00	1.7	-4.6	9.9	0.335	0.	0.166	0.166	0.041	0.041

TABLE VIII. - Continued. BLADE-ELEMENT DATA AT BLADE EDGES FOR STATOR 4

(b) 100 Percent of design speed; reading number 969

RP	RADI		ABS BETAM		REL BETAM		TOTAL TEMP		TOTAL PRESS	
	IN	OUT	IN	OUT	IN	OUT	IN	RATIO	IN	RATIO
1	23.919	23.909	37.0	4.9	37.0	4.9	350.1	0.991	16.87	0.954
2	23.452	23.459	35.7	4.9	35.7	4.9	343.8	1.000	16.72	0.980
3	21.557	21.636	35.5	0.4	35.5	0.4	336.7	0.999	16.23	0.986
4	20.114	20.267	38.5	2.1	38.5	2.1	337.4	0.993	16.24	0.969
5	19.873	20.038	39.0	1.8	39.0	1.8	336.6	0.994	15.96	0.977
6	19.629	19.809	39.6	0.4	39.6	0.4	335.5	0.995	15.72	0.979
7	19.388	19.583	40.4	-0.1	40.4	-0.1	334.5	0.995	15.46	0.990
8	19.147	19.355	40.9	-0.7	40.9	-0.7	333.9	0.996	15.37	0.993
9	17.691	18.004	38.5	0.5	38.5	0.5	332.0	0.996	15.88	0.978
10	15.756	16.238	40.6	0.3	40.6	0.3	331.4	0.999	15.93	0.974
11	15.273	15.866	42.3	3.0	42.3	3.0	333.9	0.996	16.19	0.937

RP	ABS VEL		REL VEL		MERID VEL		TANG VEL		WHEEL SPEED	
	IN	OUT	IN	OUT	IN	OUT	IN	OUT	IN	OUT
1	249.0	190.5	249.0	190.5	198.9	189.8	149.8	16.1	0.	0.
2	243.8	197.8	243.8	197.8	198.0	197.1	142.3	17.0	0.	0.
3	233.7	187.9	233.7	187.9	190.3	187.9	135.7	1.4	0.	0.
4	241.3	183.7	241.3	183.7	188.7	183.6	150.3	6.7	0.	0.
5	235.4	180.0	235.4	180.0	182.8	180.0	148.2	5.6	0.	0.
6	229.2	174.0	229.2	174.0	176.6	174.0	146.1	1.2	0.	0.
7	222.3	171.3	222.3	171.3	169.2	171.3	144.2	-0.4	0.	0.
8	220.2	170.1	220.2	170.1	166.5	170.1	144.1	-2.2	0.	0.
9	243.2	183.4	243.2	183.4	190.2	183.4	151.5	1.7	0.	0.
10	255.6	192.5	255.6	192.5	194.2	192.5	166.2	1.1	0.	0.
11	265.4	184.7	265.4	184.7	196.2	184.5	178.8	9.6	0.	0.

RP	ABS MACH NO		REL MACH NO		MERID MACH NO		MERID PEAK SS	
	IN	OUT	IN	OUT	IN	OUT	VEL R	MACH NO
1	0.695	0.524	0.695	0.524	0.555	0.522	0.954	0.990
2	0.686	0.548	0.686	0.548	0.557	0.546	0.995	0.956
3	0.663	0.525	0.663	0.525	0.540	0.525	0.987	0.907
4	0.685	0.514	0.685	0.514	0.536	0.513	0.973	0.986
5	0.668	0.503	0.668	0.503	0.519	0.503	0.984	0.968
6	0.650	0.486	0.650	0.486	0.501	0.486	0.985	0.950
7	0.630	0.479	0.630	0.479	0.479	0.479	1.012	0.934
8	0.624	0.476	0.624	0.476	0.472	0.476	1.022	0.930
9	0.697	0.516	0.697	0.516	0.545	0.516	0.965	0.948
10	0.737	0.543	0.737	0.543	0.560	0.543	0.991	0.983
11	0.766	0.519	0.766	0.519	0.566	0.518	0.940	1.044

RP	PERCENT SPAN		INCIDENCE		DEV	D-FACT	EFF	LOSS COEFF		LOSS PARAM	
	SPAN	MEAN	SS	TOT				PROF	TOT	PROF	
1	5.00	6.7	0.3	14.5	0.442	0.	0.167	0.167	0.064	0.064	
2	10.00	6.4	0.0	13.9	0.383	0.	0.073	0.073	0.027	0.027	
3	30.00	6.5	0.0	8.6	0.396	0.	0.056	0.056	0.020	0.020	
4	45.00	8.6	2.2	10.1	0.432	0.	0.115	0.115	0.037	0.037	
5	47.50	8.9	2.5	9.8	0.429	0.	0.087	0.087	0.028	0.028	
6	50.00	9.3	2.9	8.4	0.441	0.	0.083	0.083	0.027	0.027	
7	52.50	9.9	3.5	7.8	0.433	0.	0.042	0.042	0.013	0.013	
8	55.00	10.1	3.7	7.2	0.433	0.	0.030	0.030	0.009	0.009	
9	70.00	6.3	-0.1	8.5	0.421	0.	0.078	0.078	0.022	0.022	
10	90.00	5.2	-1.1	8.4	0.410	0.	0.086	0.086	0.022	0.022	
11	95.00	5.9	-0.4	11.2	0.460	0.	0.195	0.195	0.049	0.049	

TABLE VIII. - Continued. BLADE-ELEMENT DATA AT BLADE EDGES FOR STATOR 4

(c) 100 Percent of design speed; reading number 970

RP	RADII		ABS BETAM		REL BETAM		TOTAL TEMP		TOTAL PRESS	
	IN	OUT	IN	OUT	IN	OUT	IN	RATIO	IN	RATIO
1	23.919	23.909	42.9	5.5	42.9	5.5	359.6	0.987	17.73	0.948
2	23.452	23.459	40.0	5.2	40.0	5.2	351.3	1.000	17.49	0.978
3	21.557	21.636	39.8	1.5	39.8	1.5	341.5	0.999	16.82	0.980
4	20.114	20.267	42.0	2.5	42.0	2.5	339.9	0.996	16.69	0.967
5	19.873	20.038	42.2	1.9	42.2	1.9	339.3	0.997	16.51	0.972
6	19.629	19.809	43.2	0.8	43.2	0.8	338.6	0.997	16.28	0.974
7	19.388	19.583	44.9	0.5	44.9	0.5	338.3	0.996	16.06	0.982
8	19.147	19.355	45.1	0.3	45.1	0.3	338.1	0.996	16.00	0.983
9	17.691	18.004	42.2	1.8	42.2	1.8	335.0	0.997	16.29	0.973
10	15.756	16.238	43.6	0.9	43.6	0.9	333.3	1.001	16.14	0.974
11	15.273	15.806	44.9	3.9	44.9	3.9	335.2	0.998	16.47	0.935

RP	ABS VEL		REL VEL		MERID VEL		TANG VEL		WHEEL SPEED	
	IN	OUT	IN	OUT	IN	OUT	IN	OUT	IN	OUT
1	250.1	186.8	250.1	186.8	183.2	186.0	170.3	17.8	0.	0.
2	244.2	194.9	244.2	194.9	187.0	194.0	157.1	17.8	0.	0.
3	230.4	177.4	230.4	177.4	176.9	177.3	147.6	4.5	0.	0.
4	234.0	170.6	234.0	170.6	174.0	170.5	156.5	7.4	0.	0.
5	230.5	167.9	230.5	167.9	170.8	167.8	154.9	5.5	0.	0.
6	225.0	162.2	225.0	162.2	164.0	162.2	154.1	2.2	0.	0.
7	219.7	159.6	219.7	159.6	155.5	159.6	155.1	1.4	0.	0.
8	219.7	158.8	219.7	158.8	155.1	158.8	155.6	0.8	0.	0.
9	237.3	167.0	237.3	167.0	175.8	167.0	159.5	5.3	0.	0.
10	244.0	171.0	244.0	171.0	176.6	171.0	168.3	2.7	0.	0.
11	256.6	161.9	256.6	161.9	181.7	161.6	181.2	11.1	0.	0.

RP	ABS MACH NO		REL MACH NO		MERID MACH NO		MERID PEAK SS	
	IN	OUT	IN	OUT	IN	OUT	VEL R	MACH NO
1	0.688	0.507	0.688	0.507	0.504	0.505	1.015	1.119
2	0.679	0.533	0.679	0.533	0.520	0.531	1.038	1.047
3	0.647	0.491	0.647	0.491	0.497	0.490	1.003	0.983
4	0.660	0.473	0.660	0.473	0.491	0.472	0.980	1.027
5	0.650	0.465	0.650	0.465	0.482	0.465	0.983	1.013
6	0.634	0.449	0.634	0.449	0.462	0.449	0.989	1.004
7	0.618	0.442	0.618	0.442	0.438	0.442	1.026	1.011
8	0.618	0.440	0.618	0.440	0.437	0.440	1.024	1.010
9	0.676	0.466	0.676	0.466	0.501	0.465	0.950	1.004
10	0.698	0.478	0.698	0.478	0.506	0.478	0.968	1.006
11	0.736	0.451	0.736	0.451	0.521	0.450	0.889	1.069

RP	PERCENT SPAN		INCIDENCE		DEV	D-FACT	EFF	LOSS COEFF		LOSS PARAM	
	SPAN	MEAN	SS	SS				TOT	PROF	TOT	PROF
1	5.00	12.6	6.2	15.2	0.488	0.	0.190	0.190	0.073	0.073	
2	10.00	10.8	4.4	14.2	0.418	0.	0.084	0.084	0.032	0.032	
3	30.00	10.8	4.4	9.7	0.446	0.	0.083	0.083	0.029	0.029	
4	45.00	12.0	5.6	10.5	0.478	0.	0.129	0.129	0.042	0.042	
5	47.50	12.1	5.7	9.9	0.480	0.	0.114	0.114	0.037	0.037	
6	50.00	12.9	6.5	8.8	0.493	0.	0.112	0.112	0.035	0.035	
7	52.50	14.4	8.0	8.5	0.492	0.	0.079	0.079	0.025	0.025	
8	55.00	14.3	7.9	8.3	0.495	0.	0.075	0.075	0.023	0.023	
9	70.00	9.9	3.6	9.7	0.481	0.	0.103	0.103	0.030	0.030	
10	90.00	8.3	2.0	9.0	0.470	0.	0.093	0.093	0.024	0.024	
11	95.00	8.4	2.2	12.2	0.531	0.	0.216	0.216	0.054	0.054	

TABLE VIII. - Continued. BLADE-ELEMENT DATA AT BLADE EDGES FOR STATOR 4

(d) 100 Percent of design speed; reading number 975

RP	RADI I		ABS BETAM		REL BETAM		TOTAL TEMP		TOTAL PRESS	
	IN	OUT	IN	OUT	IN	OUT	IN	RATIO	IN	RATIO
1	23.919	23.909	46.1	6.7	46.1	6.7	362.8	0.989	17.80	0.951
2	23.452	23.459	44.2	6.1	44.2	6.1	356.5	1.000	17.97	0.954
3	21.557	21.636	41.7	2.5	41.7	2.5	344.5	0.999	17.15	0.969
4	20.114	20.267	43.4	2.0	43.4	2.0	341.3	0.998	16.86	0.959
5	19.873	20.038	43.6	1.9	43.6	1.9	340.7	0.998	16.73	0.961
6	19.629	19.809	45.4	1.1	45.4	1.1	340.1	0.999	16.49	0.968
7	19.388	19.583	47.6	1.2	47.6	1.2	340.0	0.998	16.33	0.976
8	19.147	19.355	47.9	1.1	47.9	1.1	340.3	0.996	16.26	0.978
9	17.691	18.004	43.3	2.4	43.3	2.4	335.8	0.999	16.35	0.967
10	15.756	16.238	44.2	2.1	44.2	2.1	333.6	1.002	16.26	0.970
11	15.273	15.806	44.7	5.0	44.7	5.0	334.6	1.001	16.52	0.934

RP	ABS VEL		REL VEL		MERID VEL		TANG VEL		WHEEL SPEED	
	IN	OUT	IN	OUT	IN	OUT	IN	OUT	IN	OUT
1	242.0	183.9	242.0	183.9	167.8	182.6	174.4	21.4	0.	0.
2	246.0	190.1	246.0	190.1	176.3	189.1	171.5	20.1	0.	0.
3	230.7	173.7	230.7	173.7	172.3	173.5	153.4	7.6	0.	0.
4	230.0	161.7	230.0	161.7	167.1	161.6	158.1	5.6	0.	0.
5	228.6	158.7	228.6	158.7	165.7	158.6	157.5	5.1	0.	0.
6	222.6	155.7	222.6	155.7	156.4	155.7	158.4	3.1	0.	0.
7	219.7	155.4	219.7	155.4	148.0	155.3	162.3	3.3	0.	0.
8	219.2	154.3	219.2	154.3	146.9	154.3	162.7	3.1	0.	0.
9	231.9	154.8	231.9	154.8	168.8	154.7	159.1	6.6	0.	0.
10	241.6	161.8	241.6	161.8	173.2	161.7	168.4	6.0	0.	0.
11	253.3	151.6	253.3	151.6	180.1	151.0	178.1	13.1	0.	0.

RP	ABS MACH NO		REL MACH NO		MERID MACH NO		MERID PEAK SS	
	IN	OUT	IN	OUT	IN	OUT	VEL R	MACH NO
1	0.661	0.496	0.661	0.496	0.458	0.493	1.088	1.146
2	0.679	0.516	0.679	0.516	0.487	0.513	1.072	1.143
3	0.645	0.477	0.645	0.477	0.482	0.477	1.007	1.020
4	0.647	0.446	0.647	0.446	0.470	0.445	0.967	1.037
5	0.643	0.438	0.643	0.438	0.466	0.437	0.958	1.031
6	0.625	0.429	0.625	0.429	0.439	0.429	0.995	1.036
7	0.617	0.428	0.617	0.428	0.415	0.428	1.049	1.065
8	0.615	0.426	0.615	0.426	0.412	0.426	1.050	1.063
9	0.658	0.429	0.658	0.429	0.479	0.429	0.916	1.002
10	0.691	0.450	0.691	0.450	0.495	0.450	0.934	1.008
11	0.726	0.420	0.726	0.420	0.516	0.419	0.839	1.049

RP	PERCENT SPAN		INCIDENCE		DEV	D-FACT	EFF	LOSS COEFF		LOSS PARAM	
	SPAN	MEAN	SS	TOT				PROF	TOT	PROF	
1	5.00	15.8	9.4	16.4	0.484	0.	0.193	0.193	0.074	0.074	
2	10.00	15.0	8.5	15.1	0.460	0.	0.173	0.173	0.065	0.065	
3	30.00	12.6	6.2	10.7	0.467	0.	0.127	0.127	0.044	0.044	
4	45.00	13.5	7.1	10.0	0.512	0.	0.167	0.167	0.054	0.054	
5	47.50	13.4	7.0	9.9	0.519	0.	0.162	0.162	0.052	0.052	
6	50.00	15.0	8.6	9.1	0.521	0.	0.136	0.136	0.043	0.043	
7	52.50	17.1	10.7	9.2	0.519	0.	0.105	0.105	0.033	0.033	
8	55.00	17.1	10.7	9.1	0.521	0.	0.097	0.097	0.030	0.030	
9	70.00	11.0	4.7	10.4	0.520	0.	0.130	0.130	0.037	0.037	
10	90.00	8.9	2.6	10.2	0.500	0.	0.111	0.111	0.028	0.028	
11	95.00	8.2	1.9	13.2	0.560	0.	0.224	0.224	0.056	0.056	

TABLE VIII. - Continued. BLADE-ELEMENT DATA AT BLADE EDGES FOR STATOR 4

(e) 100 Percent of design speed; reading number 978

RP	RADII		ABS BETAM		REL BETAM		TOTAL TEMP		TOTAL PRESS	
	IN	OUT	IN	OUT	IN	OUT	IN	RATIO	IN	RATIO
1	23.919	23.909	46.2	6.8	46.2	6.8	363.0	0.989	17.85	0.946
2	23.452	23.459	44.2	6.2	44.2	6.2	357.2	0.999	18.01	0.947
3	21.557	21.636	41.7	2.4	41.7	2.4	344.5	1.000	17.11	0.968
4	20.114	20.267	43.7	1.9	43.7	1.9	340.9	0.999	16.75	0.962
5	19.873	20.038	44.2	1.5	44.2	1.5	340.4	0.999	16.71	0.959
6	19.629	19.809	45.3	1.0	45.3	1.0	340.4	0.998	16.48	0.966
7	19.388	19.583	48.2	1.3	48.2	1.3	340.7	0.997	16.34	0.973
8	19.147	19.355	49.1	1.4	49.1	1.4	340.9	0.996	16.31	0.972
9	17.691	18.004	44.2	2.1	44.2	2.1	336.3	0.999	16.28	0.968
10	15.756	16.238	44.2	2.4	44.2	2.4	333.9	1.002	16.32	0.964
11	15.273	15.806	44.9	4.9	44.9	4.9	334.8	1.002	16.51	0.935

RP	ABS VEL		REL VEL		MERID VEL		TANG VEL		WHEEL SPEED	
	IN	OUT	IN	OUT	IN	OUT	IN	OUT	IN	OUT
1	242.4	184.0	242.4	184.0	167.7	182.7	175.1	21.7	0.	0.
2	246.4	188.9	246.4	188.9	176.7	187.8	171.7	20.5	0.	0.
3	229.8	173.0	229.8	173.0	171.6	172.9	152.7	7.2	0.	0.
4	227.2	160.2	227.2	160.2	164.3	160.1	157.0	5.2	0.	0.
5	227.4	157.8	227.4	157.8	163.0	157.8	158.5	4.2	0.	0.
6	222.5	154.2	222.5	154.2	156.4	154.2	158.2	2.6	0.	0.
7	220.0	153.8	220.0	153.8	146.7	153.8	164.0	3.4	0.	0.
8	221.2	153.0	221.2	153.0	144.8	152.9	167.2	3.7	0.	0.
9	229.9	152.6	229.9	152.6	164.9	152.5	160.2	5.6	0.	0.
10	242.9	160.4	242.9	160.4	174.1	160.3	169.4	6.8	0.	0.
11	253.2	151.6	253.2	151.6	179.2	151.0	178.8	13.0	0.	0.

RP	ABS MACH NO		REL MACH NO		MERID MACH NO		MERID PEAK SS	
	IN	OUT	IN	OUT	IN	OUT	VEL R	MACH NO
1	0.662	0.496	0.662	0.496	0.458	0.493	1.090	1.150
2	0.680	0.512	0.680	0.512	0.488	0.509	1.063	1.143
3	0.643	0.476	0.643	0.476	0.480	0.475	1.007	1.015
4	0.639	0.441	0.639	0.441	0.462	0.441	0.975	1.031
5	0.639	0.435	0.639	0.435	0.458	0.435	0.968	1.039
6	0.625	0.425	0.625	0.425	0.439	0.425	0.986	1.034
7	0.617	0.424	0.617	0.424	0.411	0.424	1.049	1.077
8	0.620	0.422	0.620	0.422	0.406	0.421	1.056	1.098
9	0.651	0.423	0.651	0.423	0.467	0.422	0.925	1.011
10	0.695	0.446	0.695	0.446	0.498	0.446	0.921	1.015
11	0.726	0.420	0.726	0.420	0.514	0.419	0.843	1.054

RP	PERCENT		INCIDENCE		DEV	D-FACT	EFF	LOSS COEFF		LOSS PARAM	
	SPAN	MEAN	SS	TOT				PROF	TOT	PROF	
1	5.00	15.9	9.5	16.5	0.485	0.	0.212	0.212	0.081	0.081	
2	10.00	14.9	8.5	15.2	0.466	0.	0.198	0.198	0.075	0.075	
3	30.00	12.6	6.2	10.6	0.467	0.	0.132	0.132	0.046	0.046	
4	45.00	13.8	7.4	9.9	0.512	0.	0.160	0.160	0.052	0.052	
5	47.50	14.1	7.7	9.6	0.523	0.	0.170	0.170	0.055	0.055	
6	50.00	15.0	8.6	9.0	0.528	0.	0.148	0.148	0.047	0.047	
7	52.50	17.6	11.3	9.3	0.529	0.	0.120	0.120	0.038	0.038	
8	55.00	18.3	11.9	9.3	0.537	0.	0.123	0.123	0.038	0.038	
9	70.00	11.9	5.5	10.0	0.528	0.	0.129	0.129	0.037	0.037	
10	90.00	8.9	2.6	10.5	0.509	0.	0.129	0.129	0.033	0.033	
11	95.00	8.5	2.2	13.1	0.561	0.	0.221	0.221	0.055	0.055	

TABLE VIII. - Continued. BLADE-ELEMENT DATA AT BLADE EDGES FOR STATOR 4

(f) 90 Percent of design speed; reading number 982

RP	RADII		ABS BETAM		REL BETAM		TOTAL TEMP		TOTAL PRESS	
	IN	OUT	IN	OUT	IN	OUT	IN	RATIO	IN	RATIO
1	23.919	23.909	20.3	2.2	20.3	2.2	318.5	0.998	12.89	0.954
2	23.452	23.459	19.8	1.3	19.8	1.3	316.3	1.000	12.91	0.987
3	21.557	21.636	21.3	-2.1	21.3	-2.1	314.4	0.999	13.07	0.982
4	20.114	20.267	24.6	-1.4	24.6	-1.4	316.9	0.994	13.28	0.976
5	19.873	20.038	25.0	-1.5	25.0	-1.5	317.2	0.993	13.26	0.973
6	19.629	19.809	25.9	-2.1	25.9	-2.1	316.2	0.995	13.02	0.982
7	19.388	19.583	26.8	-2.4	26.8	-2.4	315.3	0.998	12.77	0.997
8	19.147	19.355	27.6	-2.2	27.6	-2.2	315.4	0.997	12.73	1.002
9	17.691	18.004	26.1	-1.7	26.1	-1.7	316.4	0.998	13.71	0.981
10	15.756	16.238	30.5	1.6	30.5	1.6	319.4	1.005	14.16	0.978
11	15.273	15.806	32.4	5.5	32.4	5.5	320.9	1.005	14.33	0.903

RP	ABS VEL		REL VEL		MERID VEL		TANG VEL		WHEEL SPEED	
	IN	OUT	IN	OUT	IN	OUT	IN	OUT	IN	OUT
1	221.5	193.2	221.5	193.2	207.8	193.1	76.7	7.3	0.	0.
2	221.6	206.7	221.6	206.7	208.5	206.7	75.1	4.7	0.	0.
3	222.0	211.4	222.0	211.4	206.8	211.3	80.8	-7.9	0.	0.
4	228.9	217.9	228.9	217.9	208.1	217.9	95.4	-5.2	0.	0.
5	228.2	216.4	228.2	216.4	206.9	216.3	96.3	-5.7	0.	0.
6	219.4	213.3	219.4	213.3	197.4	213.2	95.9	-7.9	0.	0.
7	209.1	212.2	209.1	212.2	186.7	212.1	94.3	-8.8	0.	0.
8	207.0	213.2	207.0	213.2	183.5	213.1	95.8	-8.3	0.	0.
9	243.0	239.8	243.0	239.8	218.1	239.7	107.1	-7.0	0.	0.
10	260.8	269.9	260.8	269.9	224.6	269.8	132.5	7.6	0.	0.
11	264.4	249.3	264.4	249.3	223.3	248.2	141.6	23.9	0.	0.

RP	ABS MACH NO		REL MACH NO		MERID MACH NO		MERID PEAK SS	
	IN	OUT	IN	OUT	IN	OUT	VEL R	MACH NO
1	0.644	0.557	0.644	0.557	0.604	0.557	0.929	0.644
2	0.647	0.600	0.647	0.600	0.609	0.600	0.991	0.647
3	0.650	0.617	0.650	0.617	0.606	0.617	1.022	0.650
4	0.670	0.637	0.670	0.637	0.609	0.637	1.047	0.670
5	0.667	0.632	0.667	0.632	0.605	0.632	1.046	0.667
6	0.640	0.623	0.640	0.623	0.576	0.622	1.080	0.640
7	0.609	0.620	0.609	0.620	0.544	0.619	1.136	0.609
8	0.602	0.623	0.602	0.623	0.534	0.622	1.161	0.602
9	0.716	0.706	0.716	0.706	0.642	0.705	1.099	0.716
10	0.770	0.798	0.770	0.798	0.663	0.798	1.202	0.770
11	0.780	0.729	0.780	0.729	0.659	0.725	1.111	0.780

RP	PERCENT		INCIDENCE		DEV	D-FACT	EFF	LOSS COEFF		LOSS PARAM	
	SPAN	MEAN	SS	TOT				PROF	TOT	PROF	
1	5.00	-10.1	-16.5	11.8	0.249	0.	0.190	0.190	0.073	0.073	
2	10.00	-9.4	-15.9	10.3	0.187	0.	0.055	0.055	0.021	0.021	
3	30.00	-7.7	-14.1	6.1	0.187	0.	0.071	0.071	0.025	0.025	
4	45.00	-5.3	-11.7	6.7	0.191	0.	0.092	0.092	0.030	0.030	
5	47.50	-5.2	-11.6	6.5	0.195	0.	0.105	0.105	0.034	0.034	
6	50.00	-4.4	-10.8	5.9	0.178	0.	0.076	0.076	0.024	0.024	
7	52.50	-3.8	-10.2	5.6	0.139	0.	0.011	0.011	0.004	0.004	
8	55.00	-3.2	-9.6	5.7	0.125	0.	-0.011	-0.011	-0.003	-0.003	
9	70.00	-6.1	-12.5	6.3	0.147	0.	0.065	0.065	0.019	0.019	
10	90.00	-4.8	-11.1	9.7	0.086	0.	0.068	0.068	0.017	0.017	
11	95.00	-4.1	-10.4	13.7	0.165	0.	0.292	0.292	0.072	0.072	

TABLE VIII. - Continued. BLADE-ELEMENT DATA AT BLADE EDGES FOR STATOR 4

(g) 90 Percent of design speed; reading number 983

RP	RADII		ABS BETAM		REL BETAM		TOTAL TEMP		TOTAL PRESS	
	IN	OUT	IN	OUT	IN	OUT	IN	RATIO	IN	RATIO
1	23.919	23.909	29.9	4.0	29.9	4.0	331.4	0.994	14.52	0.973
2	23.452	23.459	30.3	3.3	30.3	3.3	327.5	0.999	14.49	0.990
3	21.557	21.636	28.7	-0.3	28.7	-0.3	322.4	0.999	14.33	0.989
4	20.114	20.267	31.8	0.6	31.8	0.6	323.1	0.997	14.42	0.983
5	19.873	20.038	32.3	0.9	32.3	0.9	323.1	0.996	14.38	0.982
6	19.629	19.809	32.3	0.4	32.3	0.4	322.9	0.997	14.28	0.986
7	19.388	19.583	33.5	0.2	33.5	0.2	322.7	0.996	14.20	0.988
8	19.147	19.355	34.8	-0.1	34.8	-0.1	322.2	0.997	14.04	0.997
9	17.691	18.004	32.7	-0.5	32.7	-0.5	320.6	0.999	14.35	0.989
10	15.756	16.238	36.0	-0.4	36.0	-0.4	322.4	0.998	14.62	0.981
11	15.273	15.806	37.4	2.1	37.4	2.1	323.4	0.999	14.81	0.955

RP	ABS VEL		REL VEL		MERID VEL		TANG VEL		WHEEL SPEED	
	IN	OUT	IN	OUT	IN	OUT	IN	OUT	IN	OUT
1	220.2	178.2	220.2	178.2	190.9	177.8	109.9	12.3	0.	0.
2	218.2	184.6	218.2	184.6	188.4	184.3	110.1	10.7	0.	0.
3	213.0	180.0	213.0	180.0	186.8	180.0	102.3	-1.0	0.	0.
4	219.2	182.3	219.2	182.3	186.4	182.3	115.4	2.0	0.	0.
5	219.2	181.4	219.2	181.4	185.3	181.3	117.1	2.8	0.	0.
6	216.6	180.2	216.6	180.2	183.0	180.2	115.8	1.4	0.	0.
7	214.2	178.7	214.2	178.7	178.7	178.7	118.2	0.7	0.	0.
8	209.3	177.9	209.3	177.9	172.0	177.9	119.4	-0.3	0.	0.
9	225.2	188.2	225.2	188.2	189.5	188.2	121.6	-1.5	0.	0.
10	242.1	203.3	242.1	203.3	195.9	203.3	142.2	-1.4	0.	0.
11	250.4	200.9	250.4	200.9	198.9	200.8	152.2	7.5	0.	0.

RP	ABS MACH NO		REL MACH NO		MERID MACH NO		MERID PEAK SS	
	IN	OUT	IN	OUT	IN	OUT	VEL R	MACH NO
1	0.627	0.502	0.627	0.502	0.543	0.501	0.932	0.727
2	0.625	0.523	0.625	0.523	0.539	0.522	0.978	0.746
3	0.614	0.513	0.614	0.513	0.538	0.513	0.963	0.674
4	0.632	0.520	0.632	0.520	0.538	0.520	0.978	0.753
5	0.632	0.518	0.632	0.518	0.534	0.517	0.978	0.762
6	0.624	0.514	0.624	0.514	0.528	0.514	0.985	0.748
7	0.617	0.510	0.617	0.510	0.515	0.510	1.000	0.762
8	0.603	0.508	0.603	0.508	0.495	0.508	1.035	0.768
9	0.654	0.540	0.654	0.540	0.550	0.540	0.993	0.740
10	0.705	0.584	0.705	0.584	0.571	0.584	1.038	0.815
11	0.731	0.576	0.731	0.576	0.581	0.575	1.009	0.860

RP	PERCENT	INCIDENCE		DEV	D-FACT	EFF	LOSS COEFF		LOSS PARAM	
	SPAN	MEAN	SS				TOT	PROF	TOT	PROF
1	5.00	-0.4	-6.8	13.6	0.362	0.	0.116	0.116	0.045	0.045
2	10.00	1.1	-5.4	12.3	0.327	0.	0.042	0.042	0.016	0.016
3	30.00	-0.3	-6.7	7.9	0.324	0.	0.050	0.050	0.017	0.017
4	45.00	1.8	-4.6	8.6	0.336	0.	0.072	0.072	0.023	0.023
5	47.50	2.2	-4.2	8.9	0.340	0.	0.076	0.076	0.025	0.025
6	50.00	2.0	-4.4	8.4	0.335	0.	0.059	0.059	0.019	0.019
7	52.50	2.9	-3.5	8.2	0.337	0.	0.052	0.052	0.016	0.016
8	55.00	4.0	-2.4	7.9	0.326	0.	0.014	0.014	0.004	0.004
9	70.00	0.4	-5.9	7.5	0.320	0.	0.044	0.044	0.013	0.013
10	90.00	0.6	-5.7	7.7	0.310	0.	0.067	0.067	0.017	0.017
11	95.00	0.9	-5.3	10.4	0.339	0.	0.152	0.152	0.038	0.038

TABLE VIII. - Continued. BLADE-ELEMENT DATA AT BLADE EDGES FOR STATOR 4

(h) 90 Percent of design speed; reading number 984

RP	RADII		ABS BETAM		REL BETAM		TOTAL TEMP		TOTAL PRESS	
	IN	OUT	IN	OUT	IN	OUT	IN	RATIO	IN	RATIO
1	23.919	23.909	37.2	5.1	37.2	5.1	340.1	0.991	15.44	0.970
2	23.452	23.459	36.8	4.6	36.8	4.6	335.3	0.997	15.49	0.981
3	21.557	21.636	34.7	0.7	34.7	0.7	327.6	0.998	15.02	0.986
4	20.114	20.267	36.6	1.7	36.6	1.7	326.7	0.998	14.97	0.979
5	19.873	20.038	37.1	1.7	37.1	1.7	326.4	0.998	14.90	0.981
6	19.629	19.809	38.1	1.2	38.1	1.2	326.2	0.998	14.79	0.982
7	19.388	19.583	39.7	1.1	39.7	1.1	326.3	0.997	14.68	0.985
8	19.147	19.355	41.2	0.9	41.2	0.9	326.1	0.996	14.55	0.990
9	17.691	18.004	39.6	-0.3	39.6	-0.3	323.8	0.998	14.56	0.984
10	15.756	16.238	40.6	0.8	40.6	0.8	324.4	1.000	14.94	0.979
11	15.273	15.806	41.6	2.9	41.6	2.9	325.1	1.001	15.04	0.955

RP	ABS VEL		REL VEL		MERID VEL		TANG VEL		WHEEL SPEED	
	IN	OUT	IN	OUT	IN	OUT	IN	OUT	IN	OUT
1	218.9	170.0	218.9	170.0	174.3	169.3	132.4	15.2	0.	0.
2	219.7	176.9	219.7	176.9	175.9	176.3	131.7	14.3	0.	0.
3	207.9	164.6	207.9	164.6	170.8	164.6	118.4	2.1	0.	0.
4	212.1	161.8	212.1	161.8	170.2	161.7	126.6	4.8	0.	0.
5	210.7	160.9	210.7	160.9	168.0	160.8	127.2	4.8	0.	0.
6	208.1	158.1	208.1	158.1	163.8	158.0	128.3	3.4	0.	0.
7	205.2	156.2	205.2	156.2	158.0	156.2	131.0	3.0	0.	0.
8	201.6	154.3	201.6	154.3	151.7	154.3	132.7	2.5	0.	0.
9	209.1	154.5	209.1	154.5	161.2	154.5	133.1	-0.7	0.	0.
10	231.1	175.2	231.1	175.2	175.5	175.2	150.4	2.4	0.	0.
11	238.3	168.5	238.3	168.5	178.1	168.3	158.3	8.4	0.	0.

RP	ABS MACH NO		REL MACH NO		MERID MACH NO		MERID PEAK SS	
	IN	OUT	IN	OUT	IN	OUT	VEL R	MACH NO
1	0.614	0.472	0.614	0.472	0.489	0.470	0.971	0.879
2	0.621	0.494	0.621	0.494	0.497	0.493	1.002	0.890
3	0.593	0.464	0.593	0.464	0.487	0.464	0.964	0.795
4	0.607	0.456	0.607	0.456	0.487	0.456	0.950	0.833
5	0.603	0.454	0.603	0.454	0.480	0.453	0.957	0.834
6	0.595	0.446	0.595	0.446	0.468	0.445	0.965	0.838
7	0.586	0.440	0.586	0.440	0.451	0.440	0.988	0.853
8	0.575	0.435	0.575	0.435	0.435	0.435	1.017	0.863
9	0.600	0.437	0.600	0.437	0.463	0.437	0.958	0.837
10	0.668	0.497	0.668	0.497	0.507	0.497	0.998	0.892
11	0.690	0.476	0.690	0.476	0.516	0.476	0.945	0.923

RP	PERCENT		INCIDENCE		DEV	D-FACT	EFF	LOSS COEFF		LOSS PARAM	
	SPAN	MEAN	SS	SS				TOT	PROF	TOT	PROF
1	5.00	6.9	0.5	14.8	0.430	0.	0.131	0.131	0.051	0.051	
2	10.00	7.6	1.2	13.6	0.397	0.	0.084	0.084	0.032	0.032	
3	30.00	5.7	-0.7	9.0	0.403	0.	0.068	0.068	0.024	0.024	
4	45.00	6.7	0.3	9.7	0.423	0.	0.096	0.096	0.031	0.031	
5	47.50	7.0	0.6	9.7	0.423	0.	0.088	0.088	0.028	0.028	
6	50.00	7.7	1.3	9.2	0.431	0.	0.083	0.083	0.026	0.026	
7	52.50	9.1	2.7	9.1	0.434	0.	0.071	0.071	0.022	0.022	
8	55.00	10.4	4.0	8.9	0.434	0.	0.049	0.049	0.015	0.015	
9	70.00	7.3	0.9	7.7	0.443	0.	0.075	0.075	0.022	0.022	
10	90.00	5.3	-1.0	8.9	0.404	0.	0.080	0.080	0.020	0.020	
11	95.00	5.1	-1.1	11.1	0.446	0.	0.164	0.164	0.041	0.041	

TABLE VIII. - Continued. BLADE-ELEMENT DATA AT BLADE EDGES FOR STATOR 4

(i) 90 Percent of design speed; reading number 985

RP	RADII		ABS BETAM		REL BETAM		TOTAL TEMP		TOTAL PRESS	
	IN	OUT	IN	OUT	IN	OUT	IN	RATIO	IN	RATIO
1	23.919	23.909	40.9	5.3	40.9	5.3	343.5	0.989	15.65	0.968
2	23.452	23.459	39.1	6.2	39.1	6.2	338.5	0.999	15.69	0.978
3	21.557	21.636	38.5	1.7	38.5	1.7	329.7	1.000	15.05	0.980
4	20.114	20.267	42.5	1.8	42.5	1.8	329.3	0.996	14.90	0.971
5	19.873	20.038	43.4	1.6	43.4	1.6	329.3	0.996	14.85	0.971
6	19.629	19.809	45.7	1.3	45.7	1.3	329.0	0.996	14.73	0.975
7	19.388	19.583	47.5	1.2	47.5	1.2	329.7	0.995	14.63	0.979
8	19.147	19.355	49.1	1.2	49.1	1.2	329.4	0.994	14.54	0.983
9	17.691	18.004	43.3	1.4	43.3	1.4	326.3	0.999	14.67	0.978
10	15.756	16.238	41.2	1.3	41.2	1.3	324.6	1.001	15.05	0.975
11	15.273	15.806	42.4	3.2	42.4	3.2	325.0	1.002	15.05	0.955

RP	ABS VEL		REL VEL		MERID VEL		TANG VEL		WHEEL SPEED	
	IN	OUT	IN	OUT	IN	OUT	IN	OUT	IN	OUT
1	217.5	167.5	217.5	167.5	164.3	166.8	142.5	15.5	0.	0.
2	218.4	173.8	218.4	173.8	169.6	172.8	137.6	18.9	0.	0.
3	202.6	153.3	202.6	153.3	158.6	153.2	126.1	4.4	0.	0.
4	202.9	143.9	202.9	143.9	149.7	143.8	137.0	4.6	0.	0.
5	202.2	142.4	202.2	142.4	146.8	142.3	139.0	4.1	0.	0.
6	198.8	140.4	198.8	140.4	138.9	140.4	142.2	3.2	0.	0.
7	196.9	139.5	196.9	139.5	133.1	139.4	145.1	2.8	0.	0.
8	195.7	138.4	195.7	138.4	128.1	138.4	147.9	2.9	0.	0.
9	207.2	144.2	207.2	144.2	150.8	144.1	142.1	3.4	0.	0.
10	228.3	165.3	228.3	165.3	171.9	165.2	150.3	3.7	0.	0.
11	233.8	156.4	233.8	156.4	172.7	156.2	157.6	8.7	0.	0.

RP	ABS MACH NO		REL MACH NO		MERID MACH NO		MERID PEAK SS	
	IN	OUT	IN	OUT	IN	OUT	VEL R	MACH NO
1	0.606	0.463	0.606	0.463	0.458	0.461	1.015	0.945
2	0.614	0.482	0.614	0.482	0.477	0.480	1.019	0.926
3	0.575	0.429	0.575	0.429	0.450	0.428	0.966	0.846
4	0.576	0.403	0.576	0.403	0.425	0.402	0.961	0.906
5	0.574	0.398	0.574	0.398	0.417	0.398	0.970	0.918
6	0.564	0.393	0.564	0.393	0.394	0.393	1.010	0.940
7	0.558	0.390	0.558	0.390	0.377	0.390	1.048	0.960
8	0.554	0.387	0.554	0.387	0.363	0.387	1.081	0.981
9	0.592	0.405	0.592	0.405	0.431	0.405	0.956	0.902
10	0.659	0.467	0.659	0.467	0.496	0.467	0.961	0.893
11	0.676	0.441	0.676	0.441	0.499	0.440	0.905	0.922

RP	PERCENT		INCIDENCE		DEV	D-FACT	EFF	LOSS COEFF		LOSS PARAM	
	SPAN	MEAN	SS	SS				TOT	PROF	TOT	PROF
1	5.00	10.6	4.2	15.0	0.455	0.	0.145	0.145	0.056	0.056	
2	10.00	9.8	3.4	15.2	0.410	0.	0.100	0.100	0.038	0.038	
3	30.00	9.4	3.0	9.9	0.453	0.	0.100	0.100	0.035	0.035	
4	45.00	12.5	6.1	9.9	0.502	0.	0.145	0.145	0.047	0.047	
5	47.50	13.3	6.9	9.7	0.510	0.	0.144	0.144	0.046	0.046	
6	50.00	15.3	8.9	9.3	0.515	0.	0.131	0.131	0.042	0.042	
7	52.50	16.9	10.5	9.1	0.518	0.	0.109	0.109	0.034	0.034	
8	55.00	18.3	11.9	9.2	0.521	0.	0.090	0.090	0.028	0.028	
9	70.00	11.0	4.7	9.3	0.495	0.	0.102	0.102	0.029	0.029	
10	90.00	5.8	-0.5	9.4	0.438	0.	0.100	0.100	0.026	0.026	
11	95.00	5.9	-0.4	11.4	0.486	0.	0.171	0.171	0.043	0.043	

TABLE VIII. - Continued. BLADE-ELEMENT DATA AT BLADE EDGES FOR STATOR 4

(j) 90 Percent of design speed; reading number 986

RP	RADII		ABS BETAM		REL BETAM		TOTAL TEMP		TOTAL PRESS	
	IN	OUT	IN	OUT	IN	OUT	IN	RATIO	IN	RATIO
1	23.919	23.999	48.7	6.5	48.7	6.5	347.9	0.989	15.62	0.949
2	23.452	23.459	45.5	6.7	45.5	6.7	343.8	0.997	15.71	0.950
3	21.557	21.636	45.5	1.9	45.5	1.9	334.2	1.001	15.07	0.970
4	20.114	20.267	49.3	0.8	49.3	0.8	332.9	0.996	14.95	0.963
5	19.873	20.038	50.0	0.6	50.0	0.6	332.8	0.996	14.90	0.964
6	19.629	19.809	51.2	0.2	51.2	0.2	332.4	0.996	14.76	0.970
7	19.388	19.583	52.6	-0.0	52.6	-0.0	331.9	0.996	14.65	0.977
8	19.147	19.355	53.5	-0.1	53.5	-0.1	331.6	0.996	14.59	0.980
9	17.691	18.024	44.3	1.6	44.3	1.6	327.5	1.000	14.81	0.973
10	15.756	16.238	41.5	2.3	41.5	2.3	324.8	1.003	15.16	0.969
11	15.273	15.826	42.6	4.3	42.6	4.3	325.3	1.002	15.18	0.948

RP	ABS VEL		REL VEL		MERID VEL		TANG VEL		WHEEL SPEED	
	IN	OUT	IN	OUT	IN	OUT	IN	OUT	IN	OUT
1	211.8	155.7	211.8	155.7	139.7	154.7	159.2	17.7	0.	0.
2	215.1	158.9	215.1	158.9	150.7	157.8	153.5	18.5	0.	0.
3	201.0	147.0	201.0	147.0	141.0	147.0	143.3	4.9	0.	0.
4	202.0	137.9	202.0	137.9	131.7	137.9	153.2	2.0	0.	0.
5	201.0	137.1	201.0	137.1	129.2	137.1	154.0	1.4	0.	0.
6	197.4	135.0	197.4	135.0	123.7	135.0	153.9	0.5	0.	0.
7	194.3	134.4	194.3	134.4	118.1	134.4	154.2	-0.0	0.	0.
8	193.3	133.6	193.3	133.6	115.0	133.6	155.5	-0.3	0.	0.
9	208.6	141.6	208.6	141.6	149.1	141.5	145.8	4.0	0.	0.
10	227.8	160.9	227.8	160.9	170.6	160.8	151.0	6.4	0.	0.
11	234.5	151.9	234.5	151.9	172.7	151.4	158.6	11.5	0.	0.

RP	ABS MACH NO		REL MACH NO		MERID MACH NO		MERID PEAK SS	
	IN	OUT	IN	OUT	IN	OUT	VEL R	MACH NO
1	0.586	0.426	0.586	0.426	0.386	0.423	1.107	1.069
2	0.599	0.436	0.599	0.436	0.420	0.433	1.047	1.035
3	0.566	0.438	0.566	0.408	0.397	0.407	1.043	0.967
4	0.570	0.383	0.570	0.383	0.372	0.383	1.046	1.029
5	0.567	0.381	0.567	0.381	0.365	0.381	1.061	1.034
6	0.557	0.375	0.557	0.375	0.349	0.375	1.091	1.034
7	0.548	0.374	0.548	0.374	0.333	0.374	1.138	1.039
8	0.545	0.372	0.545	0.372	0.324	0.372	1.162	1.049
9	0.595	0.396	0.595	0.396	0.425	0.396	0.949	0.927
10	0.657	0.454	0.657	0.454	0.492	0.454	0.943	0.899
11	0.678	0.427	0.678	0.427	0.499	0.426	0.877	0.929

RP	PERCENT		INCIDENCE		DEV	D-FACT	EFF	LOSS COEFF		LOSS PARAM	
	SPAN	MEAN	SS	TOT				PROF	TOT	PROF	
1	5.00	18.4	12.0	16.2	0.523	0.	0.245	0.245	0.094	0.094	
2	10.00	16.3	9.9	15.7	0.499	0.	0.233	0.233	0.088	0.088	
3	30.00	16.4	10.0	10.1	0.508	0.	0.152	0.152	0.053	0.053	
4	45.00	19.4	13.0	8.8	0.560	0.	0.189	0.189	0.061	0.061	
5	47.50	19.9	13.5	8.6	0.562	0.	0.182	0.182	0.058	0.058	
6	50.00	20.9	14.5	8.2	0.562	0.	0.157	0.157	0.050	0.050	
7	52.50	22.0	15.6	8.0	0.557	0.	0.127	0.127	0.040	0.040	
8	55.00	22.7	16.3	7.9	0.557	0.	0.110	0.110	0.034	0.034	
9	70.00	12.1	5.7	9.5	0.515	0.	0.129	0.129	0.037	0.037	
10	90.00	6.2	-0.1	10.4	0.454	0.	0.123	0.123	0.032	0.032	
11	95.00	6.1	-0.2	12.5	0.505	0.	0.198	0.198	0.049	0.049	

TABLE VIII. - Continued. BLADE-ELEMENT DATA AT BLADE EDGES FOR STATOR 4

(k) 80 Percent of design speed; reading number 987

RP	RADII		ABS BETAM		REL BETAM		TOTAL TEMP		TOTAL PRESS	
	IN	OUT	IN	OUT	IN	OUT	IN	RATIO	IN	RATIO
1	23.919	23.909	52.7	6.1	52.7	6.1	335.8	0.990	14.21	0.957
2	23.452	23.459	46.2	5.4	46.2	5.4	331.9	0.998	14.19	0.964
3	21.557	21.636	45.6	2.0	45.6	2.0	324.5	1.000	13.90	0.980
4	20.114	20.267	45.6	1.9	45.6	1.9	322.8	0.998	13.87	0.973
5	19.873	20.038	45.7	1.7	45.7	1.7	322.7	0.998	13.86	0.972
6	19.629	19.809	47.2	1.2	47.2	1.2	322.4	0.998	13.77	0.976
7	19.388	19.583	49.1	1.0	49.1	1.0	322.1	0.998	13.68	0.982
8	19.147	19.355	50.6	0.8	50.6	0.8	321.9	0.998	13.61	0.986
9	17.691	18.004	43.5	1.6	43.5	1.6	319.3	1.000	13.79	0.978
10	15.756	16.238	41.1	1.6	41.1	1.6	317.5	1.001	14.02	0.976
11	15.273	15.806	42.2	3.5	42.2	3.5	317.9	1.002	14.01	0.963

RP	ABS VEL		REL VEL		MERID VEL		TANG VEL		WHEEL SPEED	
	IN	OUT	IN	OUT	IN	OUT	IN	OUT	IN	OUT
1	185.6	132.4	185.6	132.4	112.4	131.7	147.7	14.2	0.	0.
2	185.3	135.5	185.3	135.5	128.3	134.9	133.7	12.8	0.	0.
3	179.2	133.1	179.2	133.1	125.5	133.0	128.0	4.7	0.	0.
4	181.9	127.6	181.9	127.6	127.2	127.5	129.9	4.2	0.	0.
5	182.0	126.6	182.0	126.6	127.2	126.6	130.2	3.7	0.	0.
6	178.8	125.3	178.8	125.3	121.4	125.2	131.2	2.5	0.	0.
7	176.2	124.5	176.2	124.5	115.4	124.5	133.2	2.2	0.	0.
8	174.6	124.2	174.6	124.2	110.8	124.2	134.9	1.7	0.	0.
9	187.8	130.0	187.8	130.0	136.3	129.9	129.3	3.6	0.	0.
10	203.4	146.3	203.4	146.3	153.2	146.3	133.7	4.1	0.	0.
11	209.6	140.6	209.6	140.6	155.3	140.3	140.8	8.5	0.	0.

RP	ABS MACH NO		REL MACH NO		MERID MACH NO		MERID PEAK SS	
	IN	OUT	IN	OUT	IN	OUT	VEL R	MACH NO
1	0.519	0.367	0.519	0.367	0.314	0.365	1.172	1.019
2	0.521	0.377	0.521	0.377	0.361	0.375	1.051	0.912
3	0.509	0.374	0.509	0.374	0.356	0.374	1.060	0.871
4	0.518	0.359	0.518	0.359	0.363	0.359	1.002	0.870
5	0.519	0.356	0.519	0.356	0.363	0.356	0.995	0.869
6	0.509	0.353	0.509	0.353	0.346	0.353	1.032	0.877
7	0.502	0.351	0.502	0.351	0.329	0.351	1.078	0.892
8	0.497	0.350	0.497	0.350	0.316	0.350	1.121	0.906
9	0.539	0.368	0.539	0.368	0.391	0.368	0.953	0.825
10	0.589	0.416	0.589	0.416	0.444	0.416	0.955	0.797
11	0.608	0.399	0.608	0.399	0.450	0.398	0.903	0.825

RP	PERCENT		INCIDENCE		DEV	D-FACT	EFF	LOSS COEFF		LOSS PARAM	
	SPAN	MEAN	SS	TOT				PROF	TOT	PROF	
1	5.00	22.4	16.0	15.8	0.564	0.	0.254	0.254	0.098	0.098	
2	10.00	16.9	10.5	14.4	0.516	0.	0.213	0.213	0.080	0.080	
3	30.00	16.5	10.1	10.2	0.497	0.	0.123	0.123	0.043	0.043	
4	45.00	15.7	9.3	9.9	0.523	0.	0.161	0.161	0.053	0.053	
5	47.50	15.5	9.2	9.7	0.527	0.	0.165	0.165	0.053	0.053	
6	50.00	16.9	10.5	9.2	0.527	0.	0.146	0.146	0.047	0.047	
7	52.50	18.5	12.1	9.0	0.526	0.	0.117	0.117	0.037	0.037	
8	55.00	19.8	13.4	8.8	0.524	0.	0.091	0.091	0.028	0.028	
9	70.00	11.2	4.9	9.5	0.499	0.	0.120	0.120	0.035	0.035	
10	90.00	5.8	-0.5	9.7	0.441	0.	0.113	0.113	0.029	0.029	
11	95.00	5.7	-0.6	11.7	0.483	0.	0.166	0.166	0.041	0.041	

TABLE VIII. - Continued. BLADE-ELEMENT DATA AT BLADE EDGES FOR STATOR 4

(1) 70 Percent of design speed; reading number 988

RP	RAD II		ABS BETAM		REL BETAM		TOTAL TEMP		TOTAL PRESS	
	IN	OUT	IN	OUT	IN	OUT	IN	RATIO	IN	RATIO
1	23.919	23.909	17.1	1.4	17.1	1.4	302.7	1.001	11.41	0.975
2	23.452	23.459	16.1	0.6	16.1	0.6	301.9	1.001	11.53	0.990
3	21.557	21.636	15.2	-2.2	15.2	-2.2	300.8	1.000	11.58	0.991
4	20.114	20.267	17.1	-2.4	17.1	-2.4	301.4	1.000	11.68	0.991
5	19.873	20.038	18.5	-2.1	18.5	-2.1	301.7	1.000	11.70	0.990
6	19.629	19.809	19.6	-2.1	19.6	-2.1	302.3	0.999	11.71	0.991
7	19.388	19.583	22.0	-1.5	22.0	-1.5	303.3	0.998	11.68	0.993
8	19.147	19.355	23.9	-1.2	23.9	-1.2	304.1	0.997	11.62	1.001
9	17.691	18.004	22.6	-2.3	22.6	-2.3	303.9	1.000	12.02	0.989
10	15.756	16.238	27.6	-0.9	27.6	-0.9	306.6	1.000	12.42	0.991
11	15.273	15.806	29.5	1.2	29.5	1.2	307.7	1.001	12.55	0.974

RP	ABS VEL		REL VEL		MERID VEL		TANG VEL		WHEEL SPEED	
	IN	OUT	IN	OUT	IN	OUT	IN	OUT	IN	OUT
1	170.8	152.4	170.8	152.4	163.2	152.4	50.2	3.7	0.	0.
2	175.2	164.8	175.2	164.8	168.3	164.8	48.5	1.7	0.	0.
3	172.6	168.2	172.6	168.2	166.6	168.0	45.1	-6.5	0.	0.
4	176.4	173.6	176.4	173.6	168.6	173.4	52.0	-7.4	0.	0.
5	177.1	174.7	177.1	174.7	168.0	174.6	56.1	-6.3	0.	0.
6	177.5	175.9	177.5	175.9	167.2	175.8	59.5	-6.3	0.	0.
7	176.2	176.5	176.2	176.5	163.4	176.4	65.9	-4.6	0.	0.
8	173.2	177.6	173.2	177.6	158.3	177.6	70.3	-3.6	0.	0.
9	191.7	191.2	191.7	191.2	177.0	191.1	73.6	-7.6	0.	0.
10	211.3	217.3	211.3	217.3	187.1	217.3	98.0	-3.3	0.	0.
11	215.3	218.1	215.3	218.1	187.4	218.0	106.0	4.5	0.	0.

RP	ABS MACH NO		REL MACH NO		MERID MACH NO		MERID PEAK SS	
	IN	OUT	IN	OUT	IN	OUT	VEL R	MACH NO
1	0.502	0.445	0.502	0.445	0.480	0.445	0.934	0.502
2	0.516	0.484	0.516	0.484	0.496	0.484	0.979	0.516
3	0.509	0.495	0.509	0.495	0.491	0.495	1.009	0.509
4	0.521	0.512	0.521	0.512	0.497	0.511	1.029	0.521
5	0.522	0.515	0.522	0.515	0.496	0.515	1.039	0.522
6	0.523	0.518	0.523	0.518	0.493	0.518	1.051	0.523
7	0.518	0.519	0.518	0.519	0.480	0.519	1.080	0.518
8	0.508	0.523	0.508	0.523	0.465	0.522	1.121	0.508
9	0.566	0.565	0.566	0.565	0.522	0.564	1.080	0.566
10	0.625	0.644	0.625	0.644	0.554	0.644	1.161	0.625
11	0.637	0.645	0.637	0.645	0.554	0.645	1.163	0.637

RP	PERCENT SPAN		INCIDENCE		DEV	D-FACT	EFF	LOSS COEFF		LOSS PARAM	
	SPAN	MEAN	SS	TOT				PROF	TOT	PROF	
1	5.00	-13.2	-19.6	11.1	0.213	0.	0.158	0.158	0.061	0.061	
2	10.00	-13.2	-19.6	9.6	0.160	0.	0.062	0.062	0.024	0.024	
3	30.00	-13.9	-20.3	6.0	0.130	0.	0.056	0.056	0.019	0.019	
4	45.00	-12.8	-19.2	5.6	0.126	0.	0.056	0.056	0.018	0.018	
5	47.50	-11.7	-18.1	6.0	0.127	0.	0.058	0.058	0.019	0.019	
6	50.00	-10.8	-17.2	5.9	0.127	0.	0.052	0.052	0.017	0.017	
7	52.50	-8.6	-15.0	6.5	0.124	0.	0.040	0.040	0.012	0.012	
8	55.00	-6.9	-13.2	6.8	0.106	0.	-0.005	-0.005	-0.002	-0.002	
9	70.00	-9.7	-16.1	5.7	0.123	0.	0.054	0.054	0.016	0.016	
10	90.00	-7.7	-14.0	7.2	0.093	0.	0.038	0.038	0.010	0.010	
11	95.00	-7.0	-13.3	9.4	0.102	0.	0.108	0.108	0.027	0.027	

TABLE VIII. - Continued. BLADE-ELEMENT DATA AT BLADE EDGES FOR STATOR 4

(m) 70 Percent of design speed; reading number 989

RP	RADII		ABS BETAM		REL BETAM		TOTAL TEMP		TOTAL PRESS	
	IN	OUT	IN	OUT	IN	OUT	IN	RATIO	IN	RATIO
1	23.919	23.909	24.3	2.4	24.3	2.4	309.3	0.998	12.18	0.984
2	23.452	23.459	23.7	2.1	23.7	2.1	307.7	1.000	12.22	0.994
3	21.557	21.636	23.0	-1.8	23.0	-1.8	305.4	0.999	12.18	0.994
4	20.114	20.267	25.0	-1.8	25.0	-1.8	305.6	0.999	12.20	0.993
5	19.873	20.038	26.3	-1.6	26.3	-1.6	305.7	0.999	12.22	0.993
6	19.629	19.809	27.4	-0.9	27.4	-0.9	306.4	0.999	12.24	0.992
7	19.388	19.583	29.2	-0.5	29.2	-0.5	307.3	0.998	12.24	0.992
8	19.147	19.355	30.9	-0.5	30.9	-0.5	307.8	0.997	12.17	0.997
9	17.691	18.004	28.9	-1.9	28.9	-1.9	306.6	0.999	12.36	0.993
10	15.756	16.238	32.6	0.4	32.6	0.4	308.7	1.002	12.70	0.989
11	15.273	15.806	34.3	3.0	34.3	3.0	310.0	1.002	12.82	0.961

RP	ABS VEL		REL VEL		MERID VEL		TANG VEL		WHEEL SPEED	
	IN	OUT	IN	OUT	IN	OUT	IN	OUT	IN	OUT
1	168.5	143.8	168.5	143.8	153.6	143.6	69.3	6.1	0.	0.
2	170.6	151.3	170.6	151.3	156.2	151.2	68.7	5.7	0.	0.
3	166.2	150.1	166.2	150.1	153.0	150.0	65.0	-4.7	0.	0.
4	167.7	152.0	167.7	152.0	151.9	151.9	70.9	-4.8	0.	0.
5	169.0	153.4	169.0	153.4	151.5	153.4	74.8	-4.4	0.	0.
6	170.2	154.4	170.2	154.4	151.2	154.4	78.3	-2.5	0.	0.
7	170.3	154.6	170.3	154.6	148.7	154.6	83.1	-1.4	0.	0.
8	167.9	154.6	167.9	154.6	144.1	154.6	86.2	-1.3	0.	0.
9	178.8	163.1	178.8	163.1	156.6	163.0	86.4	-5.5	0.	0.
10	198.6	184.4	198.6	184.4	167.3	184.4	107.0	1.3	0.	0.
11	205.2	177.5	205.2	177.5	169.5	177.3	115.6	9.2	0.	0.

RP	ABS MACH NO		REL MACH NO		MERID MACH NO		MERID PEAK SS	
	IN	OUT	IN	OUT	IN	OUT	VEL R	MACH NO
1	0.489	0.415	0.489	0.415	0.446	0.415	0.935	0.489
2	0.497	0.439	0.497	0.439	0.455	0.439	0.968	0.497
3	0.486	0.437	0.486	0.437	0.447	0.436	0.980	0.486
4	0.490	0.442	0.490	0.442	0.444	0.442	1.000	0.490
5	0.494	0.447	0.494	0.447	0.443	0.446	1.012	0.494
6	0.497	0.449	0.497	0.449	0.441	0.449	1.021	0.497
7	0.496	0.449	0.496	0.449	0.433	0.449	1.040	0.508
8	0.489	0.449	0.489	0.449	0.419	0.449	1.073	0.544
9	0.523	0.475	0.523	0.475	0.458	0.475	1.041	0.523
10	0.583	0.538	0.583	0.538	0.491	0.538	1.102	0.583
11	0.602	0.516	0.602	0.516	0.497	0.515	1.046	0.602

RP	PERCENT		INCIDENCE		DEV	D-FACT	EFF	LOSS COEFF		LOSS PARAM	
	SPAN	MEAN	SS	TOT				PROF	TOT	PROF	
1	5.00	-6.0	-12.4	12.1	0.291	0.	0.107	0.107	0.041	0.041	
2	10.00	-5.5	-11.9	11.1	0.253	0.	0.038	0.038	0.015	0.015	
3	30.00	-6.0	-12.4	6.4	0.243	0.	0.043	0.043	0.015	0.015	
4	45.00	-4.9	-11.3	6.2	0.240	0.	0.049	0.049	0.016	0.016	
5	47.50	-3.9	-10.2	6.4	0.242	0.	0.047	0.047	0.015	0.015	
6	50.00	-3.0	-9.3	7.0	0.243	0.	0.051	0.051	0.016	0.016	
7	52.50	-1.4	-7.7	7.5	0.248	0.	0.052	0.052	0.016	0.016	
8	55.00	0.1	-6.3	7.5	0.240	0.	0.022	0.022	0.007	0.007	
9	70.00	-3.4	-9.8	6.0	0.234	0.	0.044	0.044	0.013	0.013	
10	90.00	-2.7	-9.0	8.5	0.206	0.	0.053	0.053	0.014	0.014	
11	95.00	-2.2	-8.5	11.2	0.261	0.	0.182	0.182	0.045	0.045	

TABLE VIII. - Continued. BLADE-ELEMENT DATA AT BLADE EDGES FOR STATOR 4

(n) 70 Percent of design speed; reading number 990

RP	RADI		ABS BETAM		REL BETAM		TOTAL TEMP		TOTAL PRESS	
	IN	OUT	IN	OUT	IN	OUT	IN	RATIO	IN	RATIO
1	23.919	23.909	31.9	3.3	31.9	3.3	314.5	0.997	12.61	0.988
2	23.452	23.459	30.9	3.8	30.9	3.8	312.2	1.000	12.69	0.993
3	21.557	21.636	30.0	-0.3	30.0	-0.3	308.9	0.999	12.52	0.995
4	20.114	20.267	31.4	0.3	31.4	0.3	309.1	0.998	12.55	0.992
5	19.873	20.038	32.3	0.5	32.3	0.5	309.3	0.998	12.57	0.991
6	19.629	19.809	33.1	1.0	33.1	1.0	309.6	0.998	12.61	0.987
7	19.388	19.583	35.8	0.9	35.8	0.9	310.0	0.997	12.53	0.991
8	19.147	19.355	37.3	0.8	37.3	0.8	310.2	0.997	12.47	0.995
9	17.691	18.004	34.4	-0.9	34.4	-0.9	308.8	0.999	12.57	0.992
10	15.756	16.238	36.5	0.4	36.5	0.4	310.0	0.999	12.90	0.987
11	15.273	15.806	37.5	2.0	37.5	2.0	310.5	1.000	12.95	0.973

RP	ABS VEL		REL VEL		MERID VEL		TANG VEL		WHEEL SPEED	
	IN	OUT	IN	OUT	IN	OUT	IN	OUT	IN	OUT
1	164.7	135.7	164.7	135.7	139.9	135.5	87.0	7.9	0.	0.
2	168.2	142.6	168.2	142.6	144.4	142.2	86.3	9.4	0.	0.
3	159.2	136.0	159.2	136.0	137.8	136.0	79.6	-0.8	0.	0.
4	163.2	137.4	163.2	137.4	139.3	137.4	85.1	0.6	0.	0.
5	164.9	138.0	164.9	138.0	139.5	138.0	88.0	1.2	0.	0.
6	167.0	137.8	167.0	137.8	139.8	137.8	91.3	2.4	0.	0.
7	163.6	137.0	163.6	137.0	132.8	137.0	95.7	2.0	0.	0.
8	161.6	136.4	161.6	136.4	128.6	136.4	98.0	1.9	0.	0.
9	170.6	141.8	170.6	141.8	140.8	141.8	96.3	-2.2	0.	0.
10	190.6	160.8	190.6	160.8	153.3	160.8	113.2	1.0	0.	0.
11	196.8	158.6	196.8	158.6	156.1	158.5	119.8	5.4	0.	0.

RP	ABS MACH NO		REL MACH NO		MERID MACH NO		MERID PEAK SS	
	IN	OUT	IN	OUT	IN	OUT	VEL R	MACH NO
1	0.474	0.388	0.474	0.388	0.402	0.387	0.969	0.587
2	0.486	0.409	0.486	0.409	0.417	0.408	0.985	0.591
3	0.461	0.392	0.461	0.392	0.399	0.392	0.987	0.535
4	0.473	0.396	0.473	0.396	0.404	0.396	0.986	0.557
5	0.478	0.398	0.478	0.398	0.405	0.398	0.990	0.576
6	0.484	0.397	0.484	0.397	0.406	0.397	0.986	0.596
7	0.474	0.395	0.474	0.395	0.385	0.395	1.032	0.626
8	0.468	0.393	0.468	0.393	0.372	0.393	1.061	0.639
9	0.496	0.409	0.496	0.409	0.409	0.409	1.007	0.597
10	0.556	0.466	0.556	0.466	0.448	0.466	1.049	0.655
11	0.575	0.458	0.575	0.458	0.456	0.458	1.015	0.679

RP	PERCENT SPAN	INCIDENCE		DEV	D-FACT	EFF	LOSS COEFF		LOSS PARAM	
		MEAN	SS				TOT	PROF	TOT	PROF
1	5.00	1.6	-4.8	13.0	0.362	0.	0.082	0.082	0.031	0.031
2	10.00	1.6	-4.8	12.8	0.326	0.	0.044	0.044	0.017	0.017
3	30.00	1.0	-5.4	7.9	0.322	0.	0.037	0.037	0.013	0.013
4	45.00	1.5	-4.9	8.3	0.326	0.	0.055	0.055	0.018	0.018
5	47.50	2.1	-4.3	8.5	0.332	0.	0.062	0.062	0.020	0.020
6	50.00	2.8	-3.6	9.0	0.343	0.	0.090	0.090	0.029	0.029
7	52.50	5.2	-1.2	8.8	0.341	0.	0.060	0.060	0.019	0.019
8	55.00	6.5	0.1	8.8	0.339	0.	0.038	0.038	0.012	0.012
9	70.00	2.1	-4.3	7.1	0.333	0.	0.054	0.054	0.015	0.015
10	90.00	1.1	-5.2	8.5	0.305	0.	0.067	0.067	0.017	0.017
11	95.00	1.0	-5.3	10.2	0.336	0.	0.133	0.133	0.033	0.033

TABLE VIII. - Continued. BLADE-ELEMENT DATA AT BLADE EDGES FOR STATOR 4

(o) 70 Percent of design speed; reading number 991

RP	RADII		ABS BETAM		REL BETAM		TOTAL TEMP		TOTAL PRESS	
	IN	OUT	IN	OUT	IN	OUT	IN	RATIO	IN	RATIO
1	23.919	23.909	38.9	4.2	38.9	4.2	318.0	0.998	12.84	0.986
2	23.452	23.459	36.4	3.8	36.4	3.8	316.3	1.000	12.97	0.986
3	21.557	21.636	35.7	0.3	35.7	0.3	312.6	0.998	12.79	0.991
4	20.114	20.267	37.0	1.6	37.0	1.6	311.7	0.999	12.79	0.987
5	19.873	20.038	36.9	1.5	36.9	1.5	311.8	0.998	12.79	0.985
6	19.629	19.809	38.4	1.5	38.4	1.5	311.8	0.998	12.75	0.986
7	19.388	19.583	41.5	1.3	41.5	1.3	311.9	0.997	12.68	0.991
8	19.147	19.355	43.1	1.2	43.1	1.2	312.1	0.997	12.63	0.993
9	17.691	18.004	39.6	0.6	39.6	0.6	310.6	1.000	12.71	0.990
10	15.756	16.238	39.1	1.0	39.1	1.0	310.8	1.000	12.99	0.985
11	15.273	15.806	40.2	2.7	40.2	2.7	310.9	1.001	12.97	0.975

RP	ABS VEL		REL VEL		MERID VEL		TANG VEL		WHEEL SPEED	
	IN	OUT	IN	OUT	IN	OUT	IN	OUT	IN	OUT
1	158.9	124.1	158.9	124.1	123.6	123.7	99.9	9.0	0.	0.
2	164.8	131.1	164.8	131.1	132.8	130.8	97.7	8.7	0.	0.
3	157.7	125.7	157.7	125.7	128.1	125.7	92.0	0.7	0.	0.
4	160.6	124.3	160.6	124.3	128.3	124.3	96.7	3.5	0.	0.
5	161.6	123.7	161.6	123.7	129.2	123.7	97.1	3.3	0.	0.
6	159.8	122.4	159.8	122.4	125.2	122.4	99.3	3.1	0.	0.
7	157.0	121.9	157.0	121.9	117.5	121.8	104.1	2.8	0.	0.
8	156.1	121.0	156.1	121.0	114.0	121.0	106.6	2.5	0.	0.
9	164.8	125.9	164.8	125.9	126.9	125.9	105.1	1.4	0.	0.
10	184.1	143.3	184.1	143.3	142.9	143.3	116.1	2.4	0.	0.
11	187.1	140.9	187.1	140.9	142.9	140.7	120.8	6.8	0.	0.

RP	ABS MACH NO		REL MACH NO		MERID MACH NO		MERID PEAK SS	
	IN	OUT	IN	OUT	IN	OUT	VEL R	MACH NO
1	0.454	0.352	0.454	0.352	0.353	0.351	1.001	0.676
2	0.473	0.373	0.473	0.373	0.381	0.372	0.985	0.669
3	0.454	0.360	0.454	0.360	0.369	0.360	0.981	0.625
4	0.464	0.356	0.464	0.356	0.370	0.356	0.969	0.643
5	0.466	0.354	0.466	0.354	0.373	0.354	0.957	0.642
6	0.461	0.350	0.461	0.350	0.361	0.350	0.977	0.655
7	0.452	0.349	0.452	0.349	0.359	0.349	1.037	0.687
8	0.450	0.346	0.450	0.346	0.328	0.346	1.061	0.703
9	0.477	0.361	0.477	0.361	0.367	0.361	0.992	0.666
10	0.536	0.412	0.536	0.412	0.416	0.412	1.003	0.686
11	0.545	0.405	0.545	0.405	0.416	0.404	0.985	0.701

RP	PERCENT	INCIDENCE		DEV	D-FACT	EFF	LOSS COEFF		LOSS PARAM	
	SPAN	MEAN	SS				TOT	PROF	TOT	PROF
1	5.00	8.6	2.2	13.9	0.440	0.	0.106	0.106	0.041	0.041
2	10.00	7.1	0.7	12.8	0.409	0.	0.097	0.097	0.037	0.037
3	30.00	6.7	0.2	8.5	0.405	0.	0.071	0.071	0.025	0.025
4	45.00	7.1	0.7	9.6	0.414	0.	0.094	0.094	0.031	0.031
5	47.50	6.8	0.4	9.6	0.420	0.	0.108	0.108	0.035	0.035
6	50.00	8.1	1.7	9.4	0.425	0.	0.101	0.101	0.032	0.032
7	52.50	11.0	4.6	9.3	0.425	0.	0.071	0.071	0.022	0.022
8	55.00	12.3	5.9	9.2	0.431	0.	0.052	0.052	0.016	0.016
9	70.00	7.4	1.0	8.6	0.415	0.	0.069	0.069	0.020	0.020
10	90.00	3.7	-2.6	9.1	0.377	0.	0.083	0.083	0.021	0.021
11	95.00	3.7	-2.6	11.0	0.396	0.	0.136	0.136	0.034	0.034

TABLE VIII. - Continued. BLADE-ELEMENT DATA AT BLADE EDGES FOR STATOR 4

(p) 70 Percent of design speed; reading number 992

RP	RADI		ABS BETAM		REL BETAM		TOTAL TEMP		TOTAL PRESS	
	IN	OUT	IN	OUT	IN	OUT	IN	RATIO	IN	RATIO
1	23.919	23.999	56.4	6.6	56.4	6.6	326.6	0.987	13.26	0.959
2	23.452	23.459	49.2	6.0	49.2	6.0	322.8	0.994	13.09	0.975
3	21.557	21.636	40.7	1.7	40.7	1.7	314.7	1.000	12.92	0.987
4	20.114	20.267	41.4	2.3	41.4	2.3	313.4	0.999	12.90	0.983
5	19.873	20.038	41.9	2.6	41.9	2.6	313.4	0.999	12.89	0.983
6	19.629	19.809	43.2	1.8	43.2	1.8	313.4	0.999	12.84	0.984
7	19.388	19.583	45.9	1.6	45.9	1.6	313.3	0.998	12.76	0.990
8	19.147	19.355	47.7	1.5	47.7	1.5	313.3	0.998	12.73	0.991
9	17.691	18.004	43.7	1.2	43.7	1.2	311.9	1.000	12.77	0.989
10	15.756	16.238	40.8	1.7	40.8	1.7	311.2	1.001	13.05	0.983
11	15.273	15.836	41.7	3.3	41.7	3.3	311.3	1.001	13.05	0.971

RP	ABS VEL		REL VEL		MERID VEL		TANG VEL		WHEEL SPEED	
	IN	OUT	IN	OUT	IN	OUT	IN	OUT	IN	OUT
1	166.4	115.6	166.4	115.6	92.1	114.9	138.6	13.3	0.	0.
2	160.3	118.7	160.3	118.7	104.8	118.1	121.3	12.3	0.	0.
3	157.1	118.9	157.1	118.9	119.2	118.8	102.4	3.6	0.	0.
4	159.2	115.9	159.2	115.9	119.5	115.8	105.2	4.7	0.	0.
5	159.3	115.1	159.3	115.1	118.6	115.0	106.3	5.3	0.	0.
6	157.6	114.0	157.6	114.0	114.9	113.9	107.9	3.6	0.	0.
7	154.4	113.5	154.4	113.5	107.4	113.4	110.9	3.2	0.	0.
8	153.7	112.8	153.7	112.8	103.5	112.7	113.7	2.9	0.	0.
9	161.6	116.4	161.6	116.4	116.9	116.4	111.6	2.4	0.	0.
10	180.5	132.6	180.5	132.6	136.6	132.5	117.9	3.9	0.	0.
11	185.0	131.6	185.0	131.6	138.2	131.4	123.0	7.5	0.	0.

RP	ABS MACH NO		REL MACH NO		MERID MACH NO		MERID PEAK SS	
	IN	OUT	IN	OUT	IN	OUT	VEL R	MACH NO
1	0.469	0.325	0.469	0.325	0.260	0.322	1.248	0.985
2	0.454	0.334	0.454	0.334	0.297	0.333	1.127	0.842
3	0.451	0.338	0.451	0.338	0.342	0.338	0.997	0.697
4	0.458	0.330	0.458	0.330	0.344	0.330	0.969	0.703
5	0.458	0.328	0.458	0.328	0.341	0.328	0.969	0.708
6	0.453	0.325	0.453	0.325	0.330	0.325	0.992	0.718
7	0.444	0.323	0.444	0.323	0.309	0.323	1.056	0.740
8	0.442	0.321	0.442	0.321	0.297	0.321	1.089	0.760
9	0.466	0.332	0.466	0.332	0.337	0.332	0.995	0.716
10	0.524	0.380	0.524	0.380	0.397	0.380	0.970	0.703
11	0.538	0.377	0.538	0.377	0.402	0.377	0.951	0.721

RP	PERCENT SPAN	INCIDENCE		DEV	D-FACT	EFF	LOSS COEFF		LOSS PARAM	
		MEAN	SS				TOT	PROF	TOT	PROF
1	5.00	26.1	19.7	16.3	0.596	0.	0.292	0.292	0.112	0.112
2	10.00	19.9	13.5	15.0	0.517	0.	0.191	0.191	0.072	0.072
3	30.00	11.6	5.2	9.9	0.462	0.	0.099	0.099	0.034	0.034
4	45.00	11.4	5.0	10.3	0.477	0.	0.126	0.126	0.041	0.041
5	47.50	11.7	5.4	10.6	0.481	0.	0.128	0.128	0.041	0.041
6	50.00	12.9	6.5	9.8	0.486	0.	0.121	0.121	0.038	0.038
7	52.50	15.4	9.0	9.6	0.483	0.	0.080	0.080	0.025	0.025
8	55.00	16.9	10.5	9.4	0.489	0.	0.069	0.069	0.021	0.021
9	70.00	11.4	5.1	9.1	0.472	0.	0.076	0.076	0.022	0.022
10	90.00	5.4	-0.9	9.8	0.425	0.	0.102	0.102	0.026	0.026
11	95.00	5.2	-1.1	11.5	0.441	0.	0.162	0.162	0.040	0.040

TABLE VIII. - Continued. BLADE-ELEMENT DATA AT BLADE EDGES FOR STATOR 4

(q) 60 Percent of design speed; reading number 993

RP	RADII		ABS BETAM		REL BETAM		TOTAL TEMP		TOTAL PRESS	
	IN	OUT	IN	OUT	IN	OUT	IN	RATIO	IN	RATIO
1	23.919	23.909	55.8	7.8	55.8	7.8	316.2	0.990	12.37	0.967
2	23.452	23.459	49.2	7.9	49.2	7.9	313.4	0.995	12.26	0.979
3	21.557	21.636	40.2	2.0	40.2	2.0	307.2	1.000	12.10	0.990
4	20.114	20.267	40.7	2.8	40.7	2.8	306.5	0.999	12.09	0.987
5	19.873	20.038	41.3	2.6	41.3	2.6	306.3	0.999	12.08	0.987
6	19.629	19.809	43.2	2.2	43.2	2.2	306.3	0.999	12.04	0.988
7	19.388	19.583	45.4	2.0	45.4	2.0	306.2	0.999	12.00	0.991
8	19.147	19.355	47.6	1.9	47.6	1.9	306.3	0.998	11.96	0.993
9	17.691	18.004	44.3	1.8	44.3	1.8	305.4	0.999	12.00	0.991
10	15.756	16.238	40.6	1.9	40.6	1.9	304.5	1.001	12.17	0.989
11	15.273	15.806	41.4	3.7	41.4	3.7	304.7	1.001	12.19	0.979

RP	ABS VEL		REL VEL		MERID VEL		TANG VEL		WHEEL SPEED	
	IN	OUT	IN	OUT	IN	OUT	IN	OUT	IN	OUT
1	142.4	99.0	142.4	99.0	80.1	98.1	117.7	13.4	0.	0.
2	136.9	101.4	136.9	101.4	89.4	100.4	103.6	14.0	0.	0.
3	132.4	101.0	132.4	101.0	101.2	101.0	85.5	3.5	0.	0.
4	134.7	98.6	134.7	98.6	102.2	98.5	87.8	4.9	0.	0.
5	134.6	97.9	134.6	97.9	101.1	97.8	88.9	4.4	0.	0.
6	132.9	96.3	132.9	96.3	96.9	96.2	91.0	3.8	0.	0.
7	131.1	95.7	131.1	95.7	92.1	95.7	93.3	3.4	0.	0.
8	129.9	95.3	129.9	95.3	87.6	95.2	95.9	3.2	0.	0.
9	137.1	98.6	137.1	98.6	98.1	98.5	95.7	3.1	0.	0.
10	151.9	113.4	151.9	113.4	115.4	113.3	98.8	3.7	0.	0.
11	156.9	111.8	156.9	111.8	117.8	111.6	103.7	7.2	0.	0.

RP	ABS MACH NO		REL MACH NO		MERID MACH NO		MERID PEAK SS	
	IN	OUT	IN	OUT	IN	OUT	VEL R	MACH NO
1	0.406	0.281	0.406	0.281	0.228	0.279	1.226	0.843
2	0.392	0.289	0.392	0.289	0.256	0.286	1.123	0.726
3	0.382	0.290	0.382	0.290	0.292	0.290	0.998	0.585
4	0.390	0.284	0.390	0.284	0.296	0.283	0.964	0.589
5	0.389	0.281	0.389	0.281	0.292	0.281	0.968	0.595
6	0.384	0.277	0.384	0.277	0.280	0.277	0.994	0.609
7	0.379	0.275	0.379	0.275	0.266	0.275	1.039	0.626
8	0.375	0.274	0.375	0.274	0.253	0.274	1.087	0.645
9	0.397	0.284	0.397	0.284	0.284	0.284	1.004	0.619
10	0.443	0.327	0.443	0.327	0.336	0.327	0.982	0.591
11	0.458	0.323	0.458	0.323	0.344	0.322	0.947	0.608

RP	PERCENT		INCIDENCE		DEV	D-FACT	EFF	LOSS COEFF		LOSS PARAM	
	SPAN	MEAN	SS	SS				TOT	PROF	TOT	PROF
1	5.00	25.5	19.1	17.5	0.587	0.	0.304	0.304	0.116	0.116	
2	10.00	19.9	13.5	16.9	0.507	0.	0.208	0.208	0.078	0.078	
3	30.00	11.2	4.7	10.2	0.452	0.	0.100	0.100	0.035	0.035	
4	45.00	10.7	4.3	10.8	0.467	0.	0.128	0.128	0.042	0.042	
5	47.50	11.2	4.8	10.6	0.474	0.	0.132	0.132	0.043	0.043	
6	50.00	12.9	6.5	10.2	0.483	0.	0.123	0.123	0.039	0.039	
7	52.50	14.8	8.4	10.0	0.484	0.	0.097	0.097	0.030	0.030	
8	55.00	16.8	10.4	9.9	0.487	0.	0.073	0.073	0.023	0.023	
9	70.00	12.0	5.7	9.7	0.473	0.	0.087	0.087	0.025	0.025	
10	90.00	5.2	-1.1	10.0	0.411	0.	0.085	0.085	0.022	0.022	
11	95.00	4.9	-1.4	11.9	0.437	0.	0.158	0.158	0.039	0.039	

TABLE VIII. - Concluded. BLADE-ELEMENT DATA AT BLADE EDGES FOR STATOR 4

(r) 50 Percent of design speed; reading number 994

RP	RADII		ABS BETAM		REL BETAM		TOTAL TEMP		TOTAL PRESS	
	IN	OUT	IN	OUT	IN	OUT	IN	RATIO	IN	RATIO
1	23.919	23.909	54.9	8.0	54.9	8.0	307.9	0.992	11.68	0.976
2	23.452	23.459	49.4	7.8	49.4	7.8	305.8	0.996	11.58	0.986
3	21.557	21.636	39.3	2.0	39.3	2.0	301.5	1.000	11.47	0.994
4	20.114	20.267	41.2	3.2	41.2	3.2	300.8	1.000	11.47	0.991
5	19.873	20.038	41.7	2.7	41.7	2.7	300.7	0.999	11.46	0.991
6	19.629	19.809	43.4	2.2	43.4	2.2	300.7	0.999	11.45	0.991
7	19.388	19.583	46.0	2.7	46.0	2.7	300.9	0.998	11.42	0.993
8	19.147	19.355	47.7	2.1	47.7	2.1	300.8	0.998	11.39	0.995
9	17.691	18.004	44.3	2.2	44.3	2.2	300.3	0.999	11.42	0.993
10	15.756	16.238	40.5	1.9	40.5	1.9	299.6	1.001	11.53	0.992
11	15.273	15.806	41.5	3.8	41.5	3.8	299.5	1.001	11.53	0.986

RP	ABS VEL		REL VEL		MERID VEL		TANG VEL		WHEEL SPEED	
	IN	OUT	IN	OUT	IN	OUT	IN	OUT	IN	OUT
1	119.2	83.3	119.2	83.3	68.7	82.5	97.5	11.6	0.	0.
2	114.0	85.1	114.0	85.1	74.1	84.3	86.6	11.6	0.	0.
3	110.3	84.2	110.3	84.2	85.3	84.2	69.8	2.9	0.	0.
4	112.0	81.8	112.0	81.8	84.2	81.7	73.8	4.6	0.	0.
5	112.0	81.3	112.0	81.3	83.6	81.2	74.5	3.8	0.	0.
6	111.2	80.2	111.2	80.2	80.7	80.1	76.5	3.0	0.	0.
7	109.7	79.9	109.7	79.9	76.2	79.8	78.8	3.7	0.	0.
8	108.2	79.1	108.2	79.1	72.9	79.1	80.0	2.9	0.	0.
9	114.5	82.5	114.5	82.5	81.9	82.4	80.0	3.2	0.	0.
10	127.0	94.9	127.0	94.9	96.6	94.9	82.5	3.2	0.	0.
11	129.6	92.4	129.6	92.4	97.1	92.2	85.9	6.1	0.	0.

RP	ABS MACH NO		REL MACH NO		MERID MACH NO		MERID PEAK SS	
	IN	OUT	IN	OUT	IN	OUT	VEL R	MACH NO
1	0.343	0.239	0.343	0.239	0.197	0.237	1.202	0.701
2	0.329	0.245	0.329	0.245	0.214	0.242	1.137	0.612
3	0.320	0.244	0.320	0.244	0.248	0.243	0.987	0.480
4	0.326	0.237	0.326	0.237	0.245	0.236	0.970	0.499
5	0.325	0.235	0.325	0.235	0.243	0.235	0.971	0.502
6	0.323	0.232	0.323	0.232	0.235	0.232	0.992	0.515
7	0.319	0.231	0.319	0.231	0.221	0.231	1.047	0.532
8	0.314	0.229	0.314	0.229	0.212	0.229	1.085	0.541
9	0.333	0.239	0.333	0.239	0.238	0.239	1.006	0.519
10	0.371	0.276	0.371	0.276	0.282	0.275	0.983	0.494
11	0.379	0.268	0.379	0.268	0.284	0.267	0.950	0.505

RP	PERCENT SPAN	INCIDENCE		DEV	D-FACT	EFF	LOSS COEFF		LOSS PARAM	
		MEAN	SS				TOT	PROF	TOT	PROF
1	5.00	24.5	18.1	17.7	0.579	0.	0.309	0.309	0.118	0.118
2	10.00	20.2	13.8	16.8	0.503	0.	0.195	0.195	0.073	0.073
3	30.00	10.3	3.8	10.2	0.447	0.	0.090	0.090	0.032	0.032
4	45.00	11.3	4.9	11.2	0.470	0.	0.131	0.131	0.043	0.043
5	47.50	11.6	5.2	10.7	0.476	0.	0.134	0.134	0.043	0.043
6	50.00	13.1	6.7	10.2	0.488	0.	0.132	0.132	0.042	0.042
7	52.50	15.4	9.0	10.7	0.485	0.	0.107	0.107	0.034	0.034
8	55.00	16.9	10.5	10.1	0.489	0.	0.080	0.080	0.025	0.025
9	70.00	12.1	5.7	10.1	0.470	0.	0.089	0.089	0.025	0.025
10	90.00	5.2	-1.1	10.0	0.410	0.	0.085	0.085	0.021	0.021
11	95.00	5.0	-1.3	12.0	0.437	0.	0.149	0.149	0.037	0.037

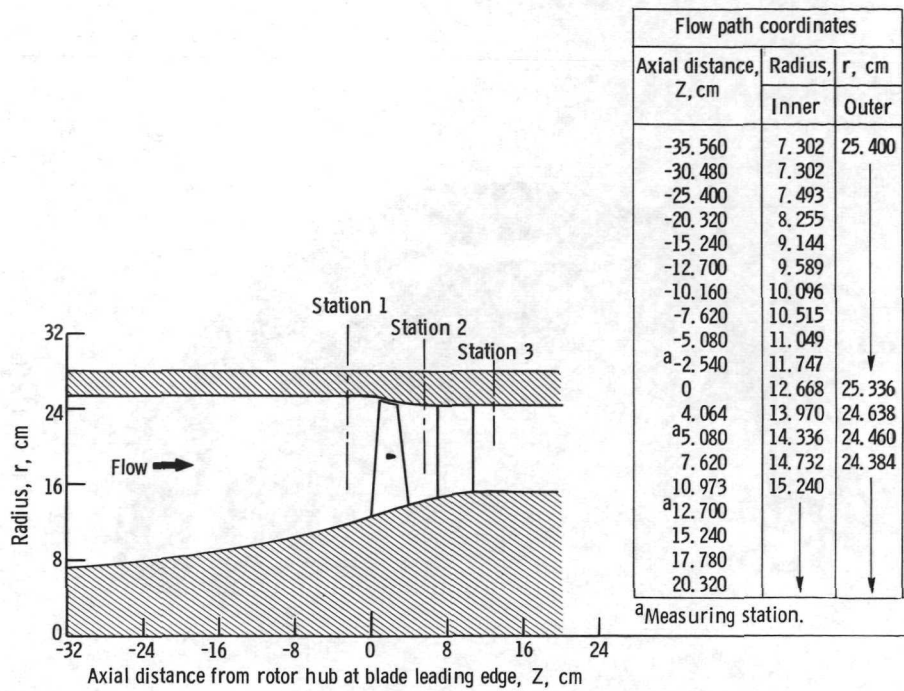

Figure 1. - Flow path for stage showing axial location of instrumentation.

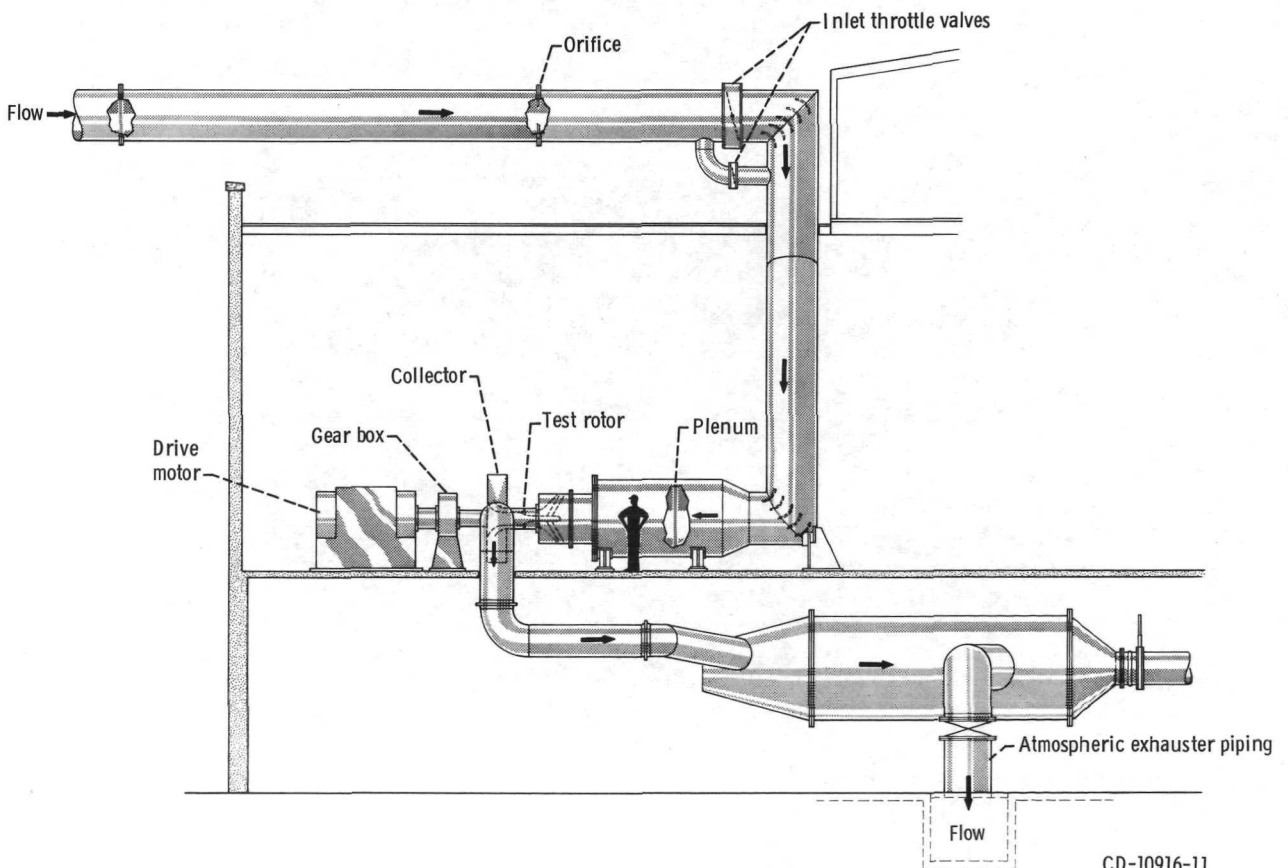

Figure 2. - Test facility.

CD-10916-11

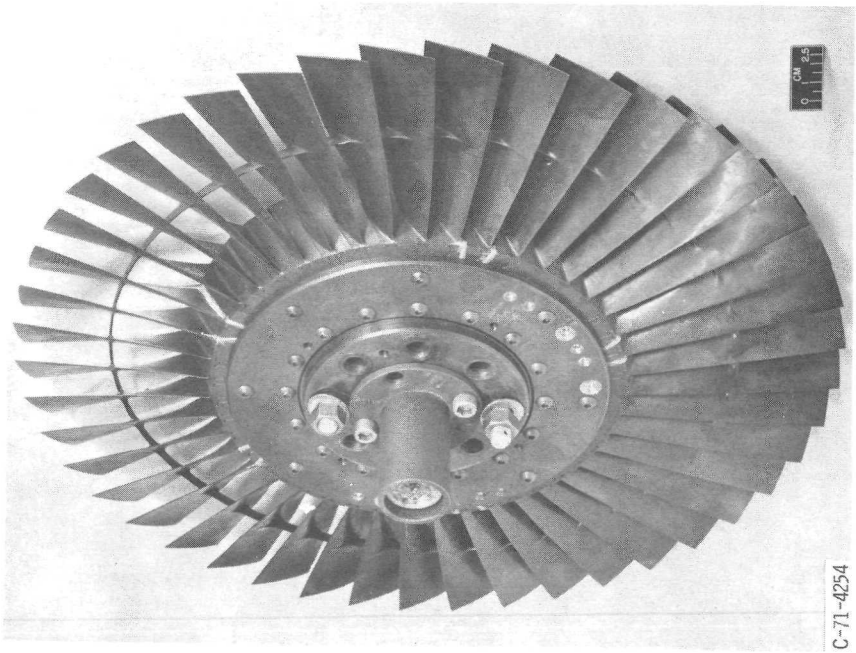

Figure 3. - Rotor 11.

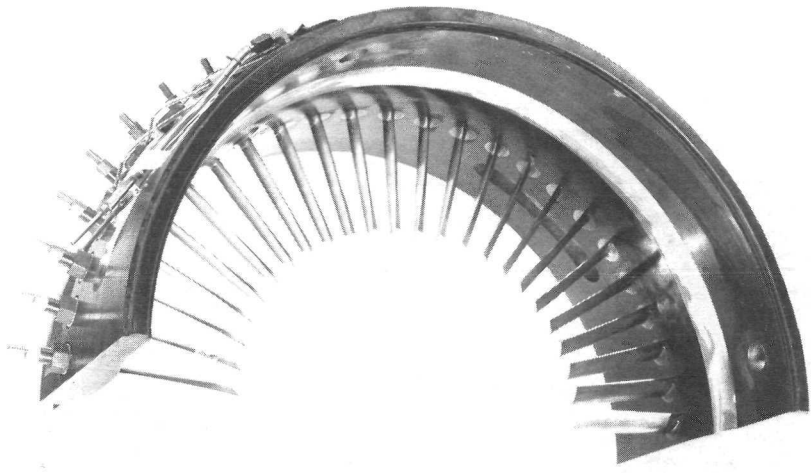
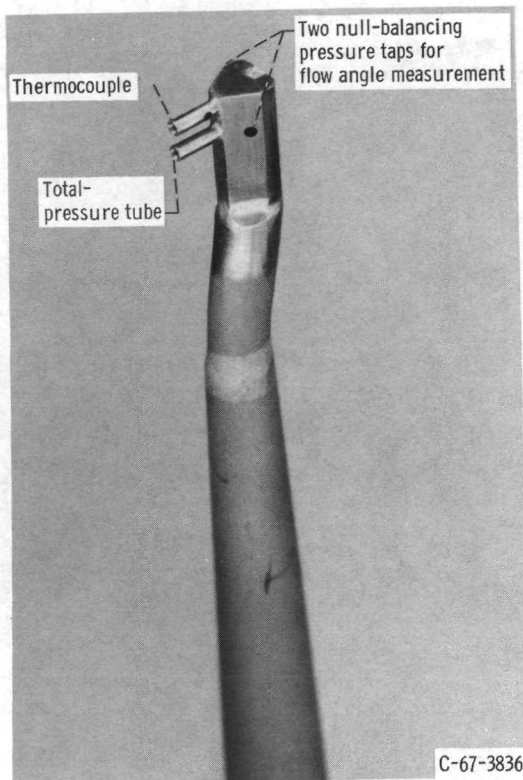
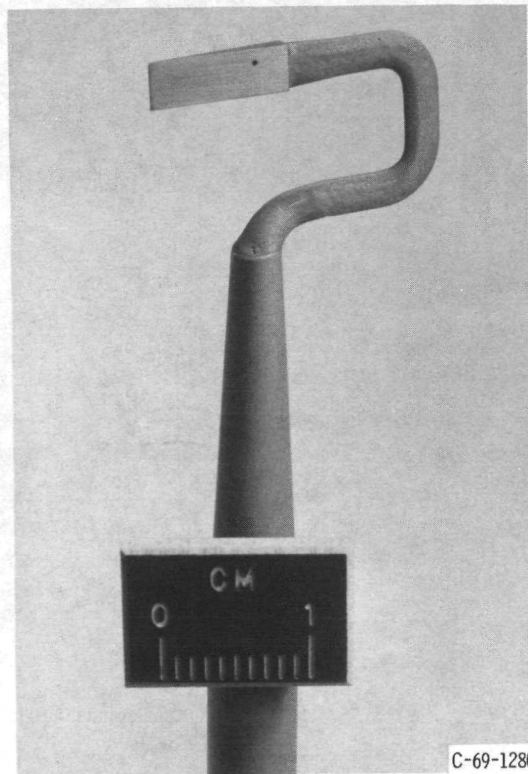

Figure 4. - Stator 4.



(a) Combination total pressure, total temperature, and flow angle probe (double barrel).

C-67-3836



(b) Static pressure probe.

C-69-1280

Figure 5. - Survey probes.

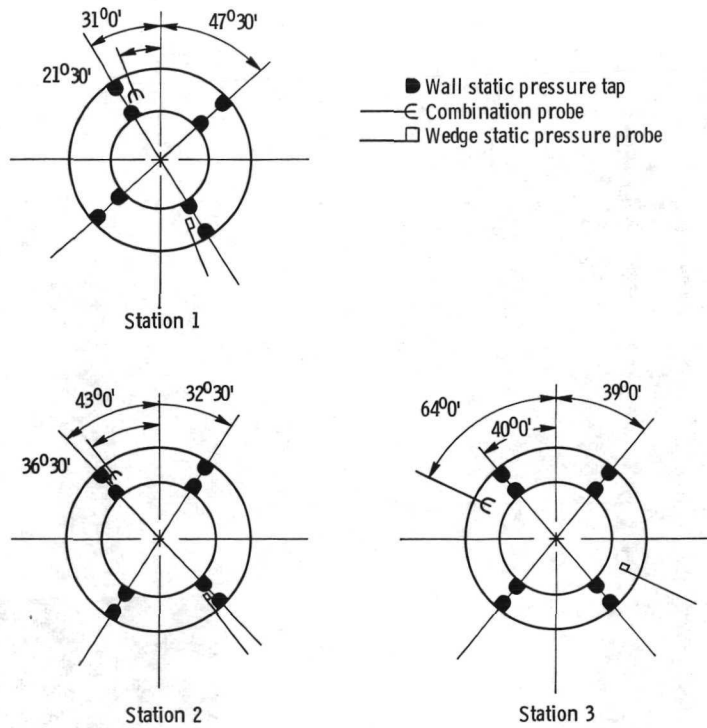

Figure 6. - Circumferential locations of measurements (looking downstream; clockwise rotation).

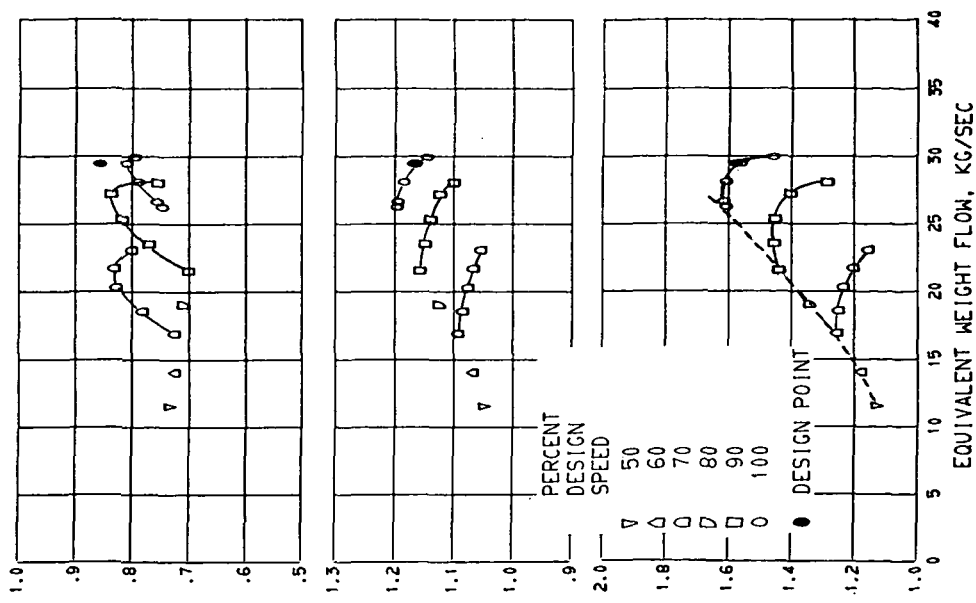

FIGURE 8. - OVERALL PERFORMANCE FOR STAGE 11-4.

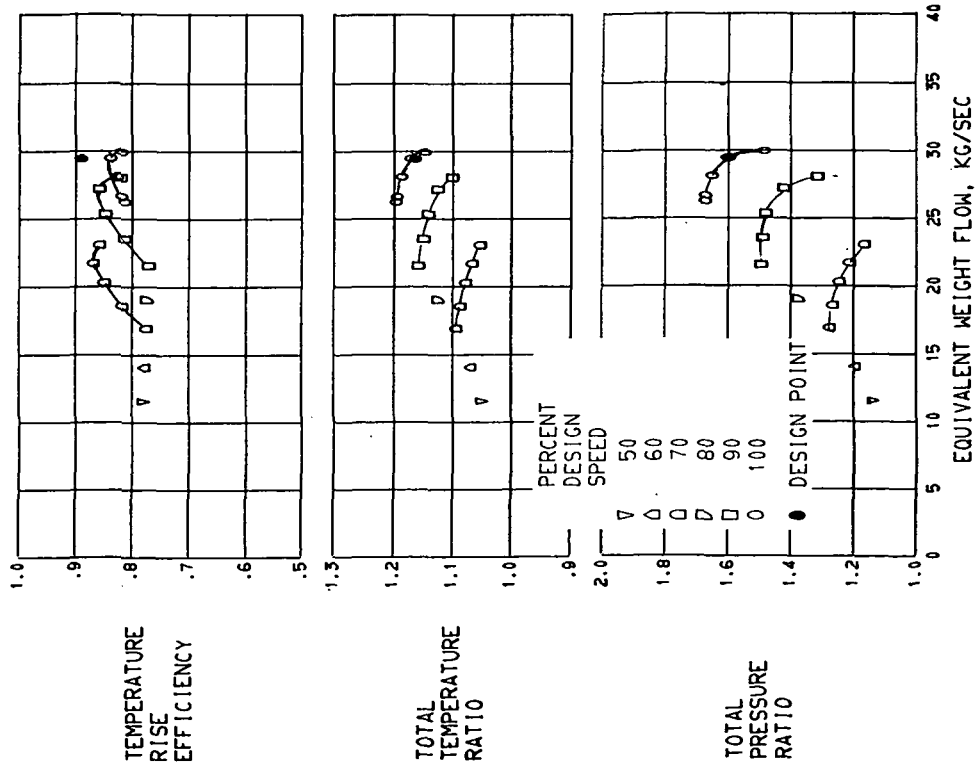

FIGURE 7. - OVERALL PERFORMANCE FOR ROTOR 11.

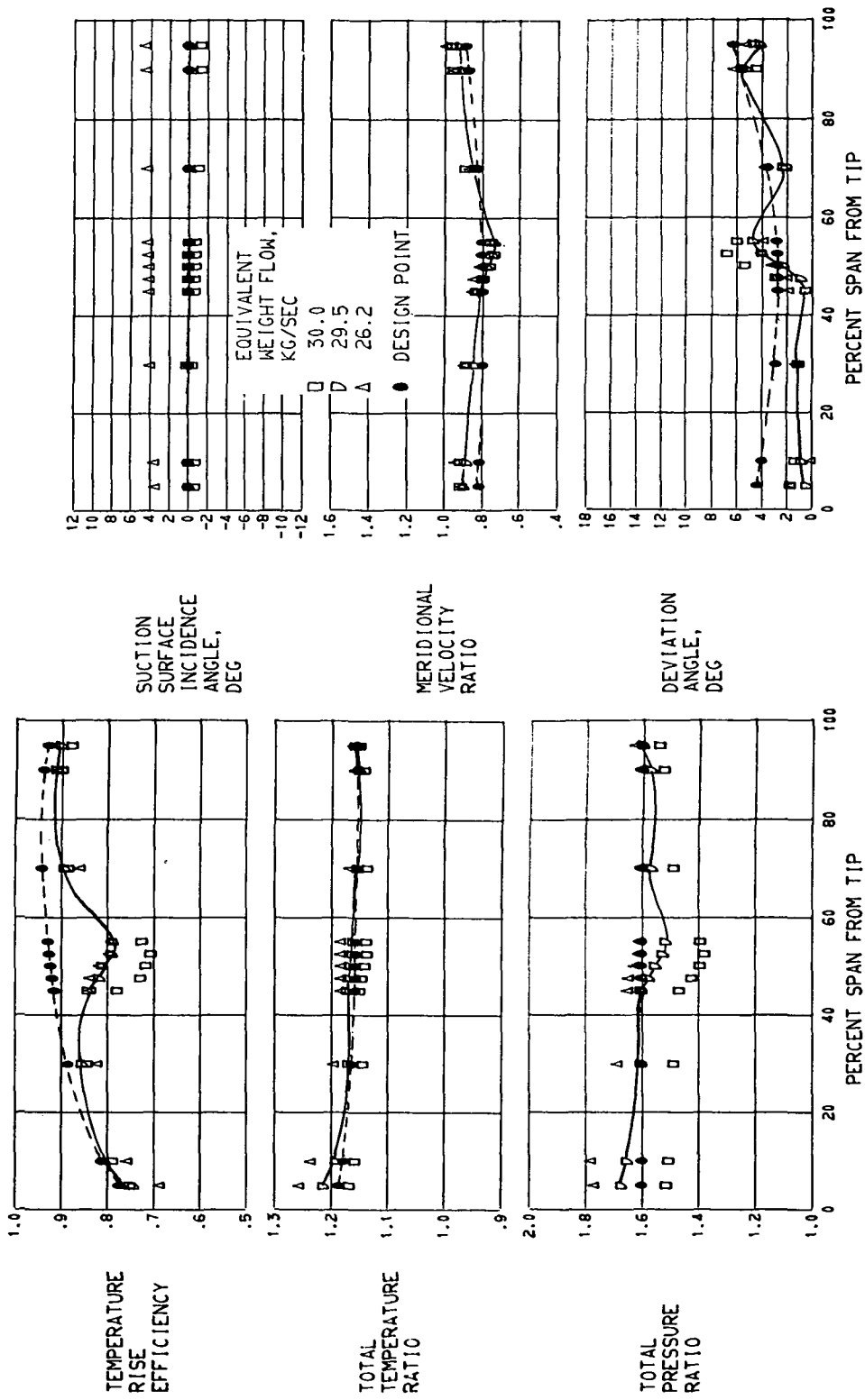

FIGURE 9. - RADIAL DISTRIBUTION OF PERFORMANCE FOR ROTOR 11, 100 PERCENT DESIGN SPEED.

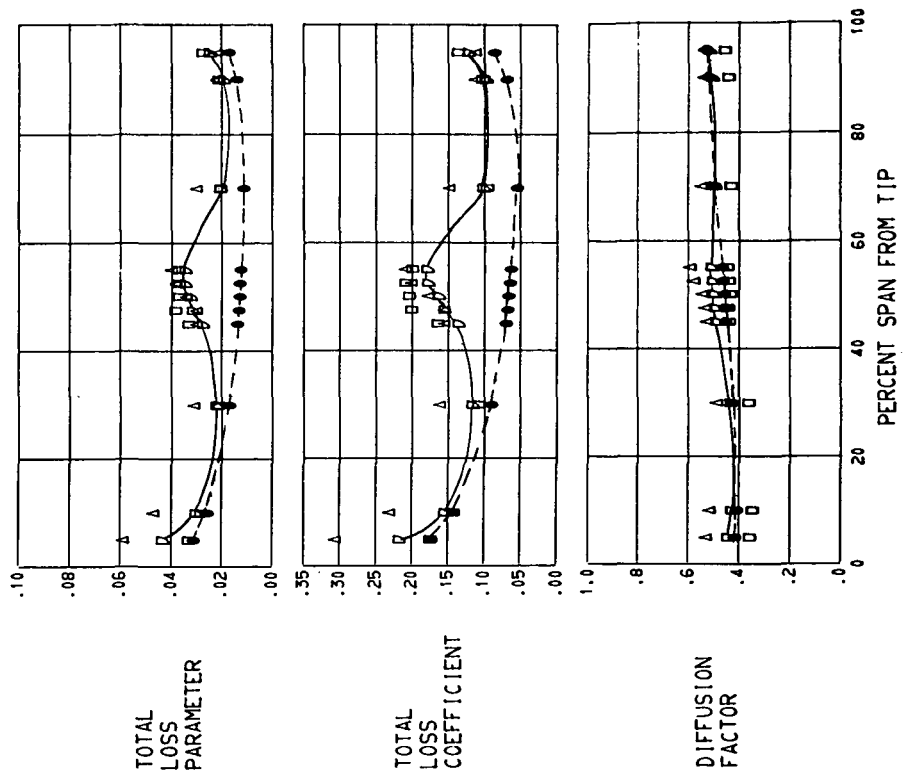

FIGURE 9. - CONCLUDED, RADIAL DISTRIBUTION OF PERFORMANCE FOR ROTOR 11, 100 PERCENT DESIGN SPEED.

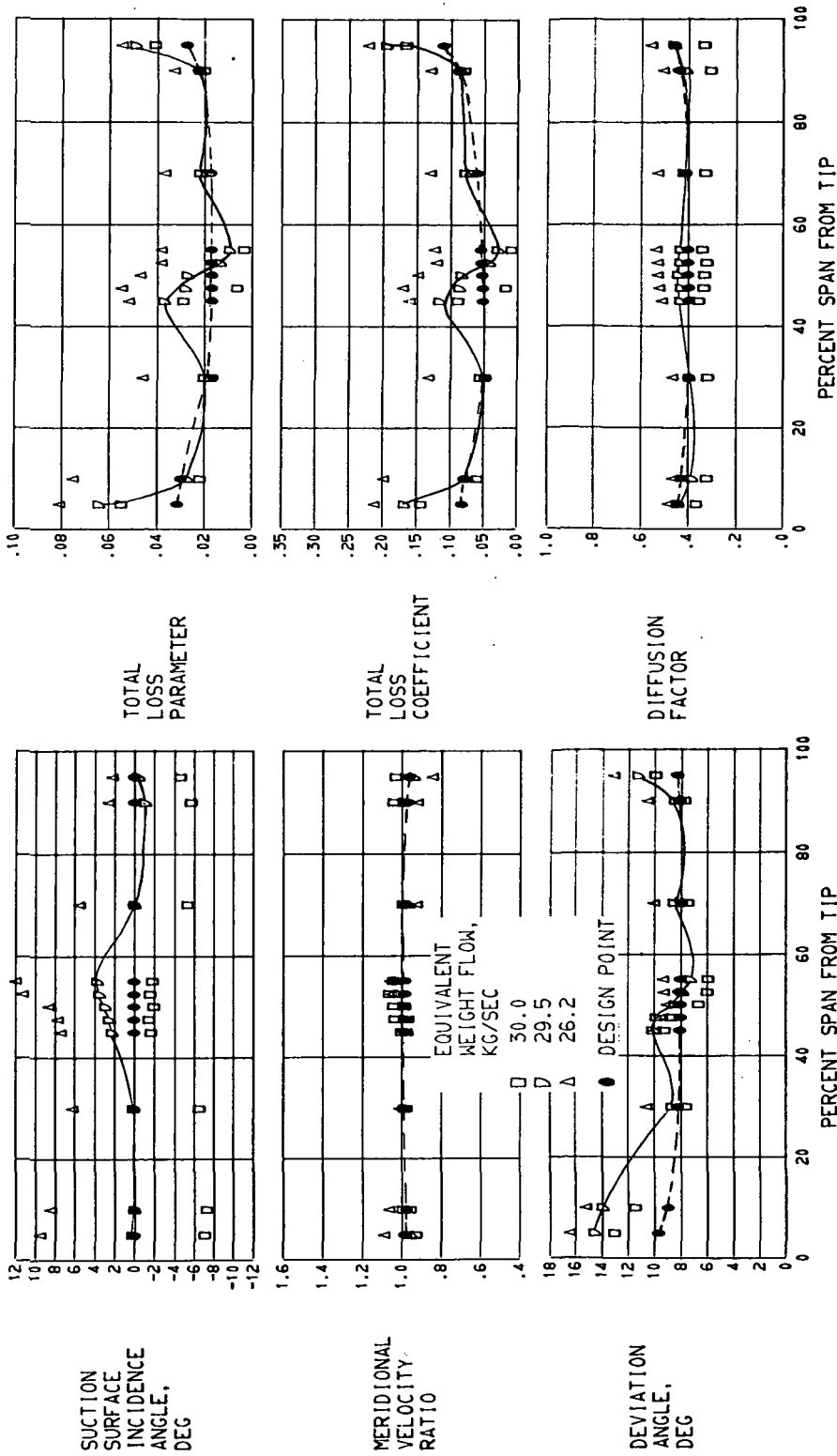
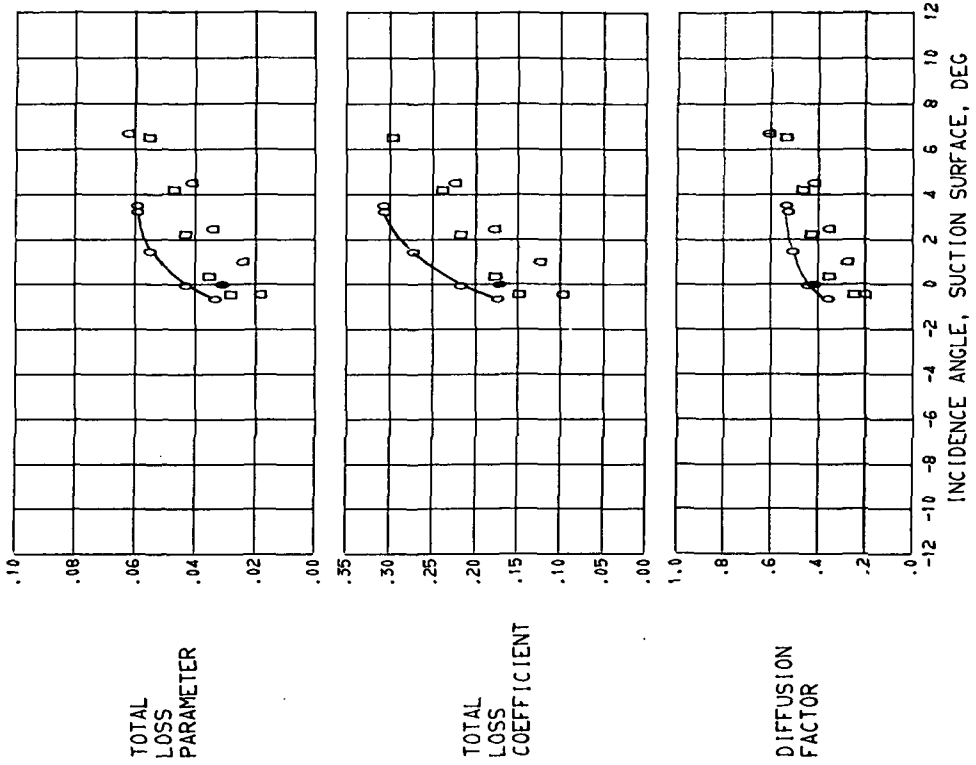
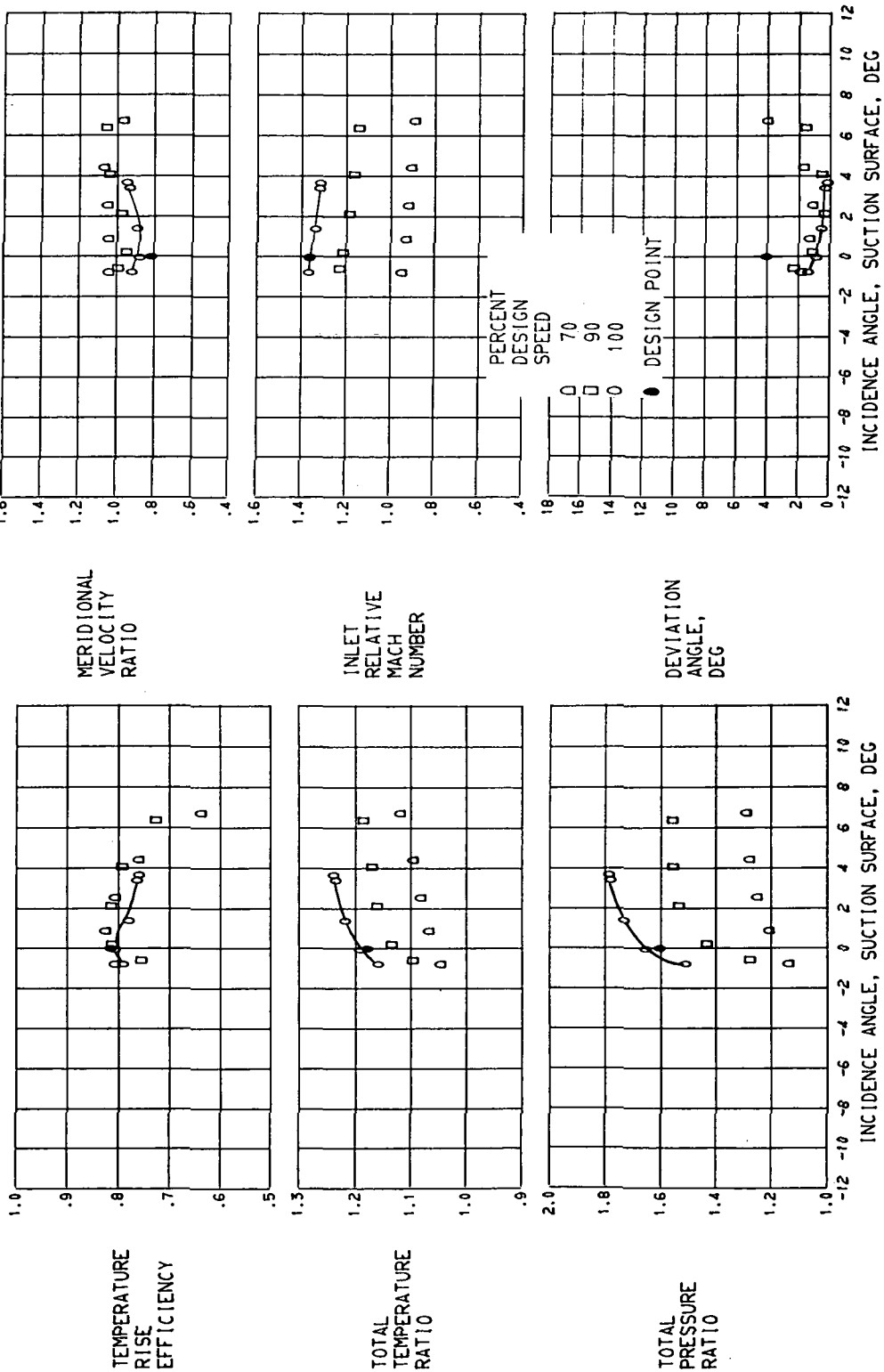
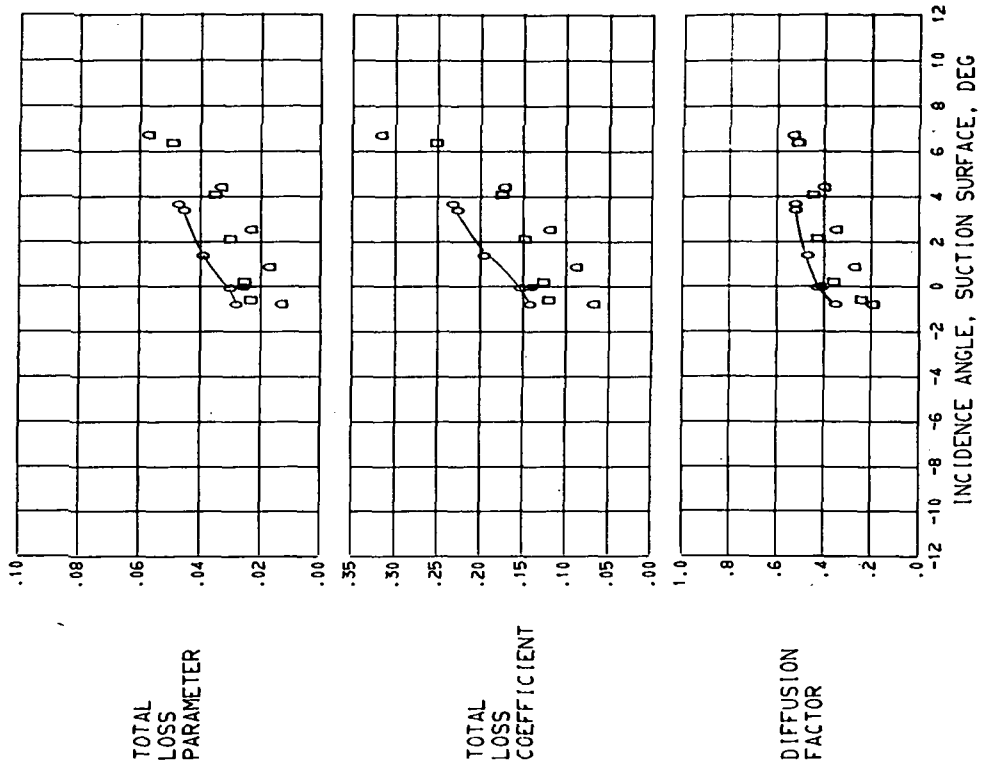

FIGURE 10. - RADIAL DISTRIBUTION OF PERFORMANCE FOR STATOR 4, 100 PERCENT DESIGN SPEED.



(A) 5.0 PERCENT SPAN.
 FIGURE 11. - BLADE ELEMENT PERFORMANCE FOR ROTOR 11.





(B) 10.0 PERCENT SPAN.
 FIGURE 11. - CONTINUED. BLADE ELEMENT PERFORMANCE FOR ROTOR 11.

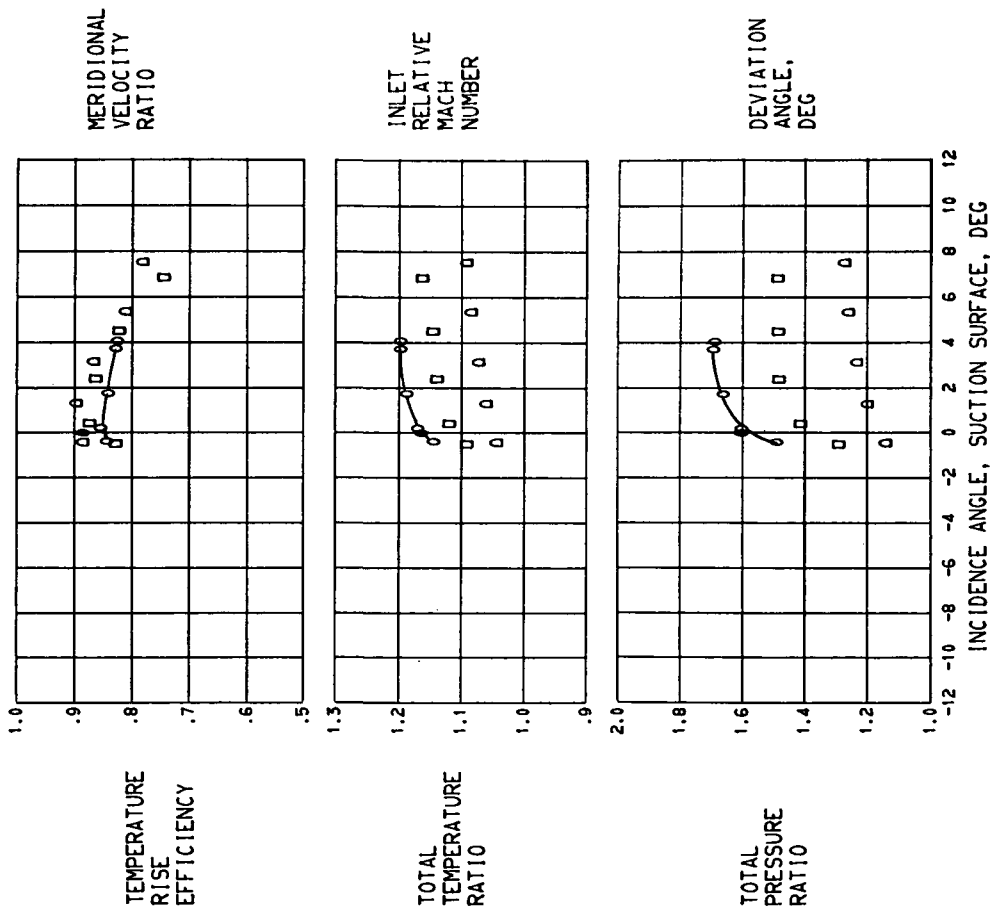
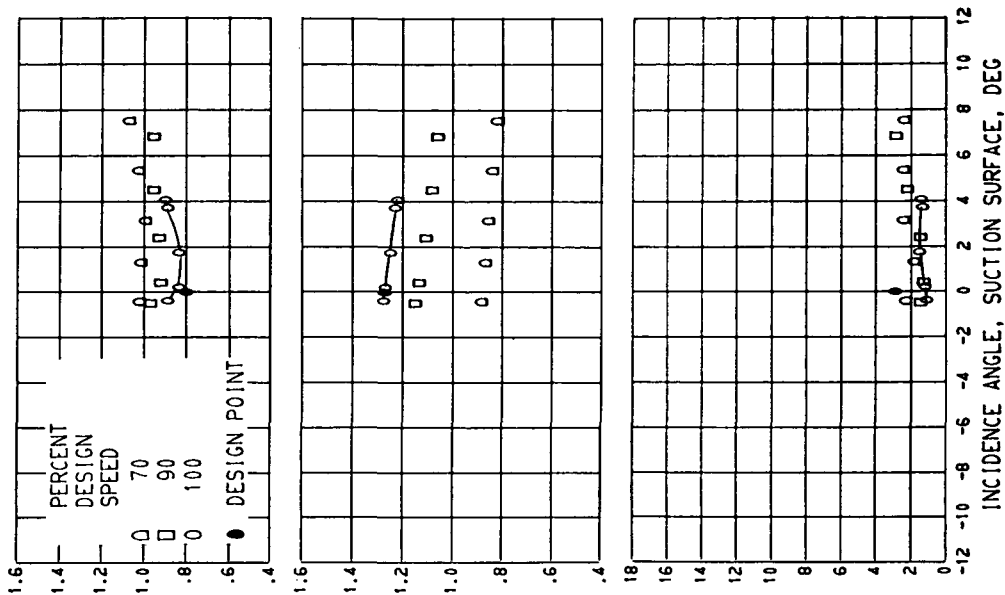

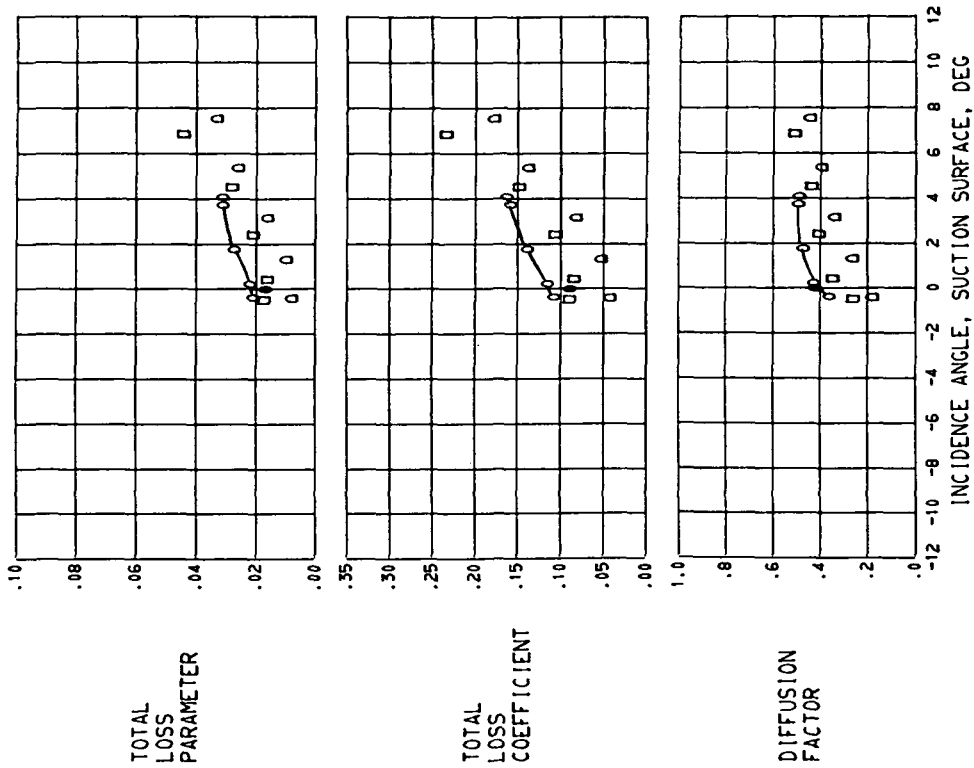

(C) 30.0 PERCENT SPAN
 FIGURE 11. - CONTINUED. BLADE ELEMENT PERFORMANCE FOR ROTOR 11.

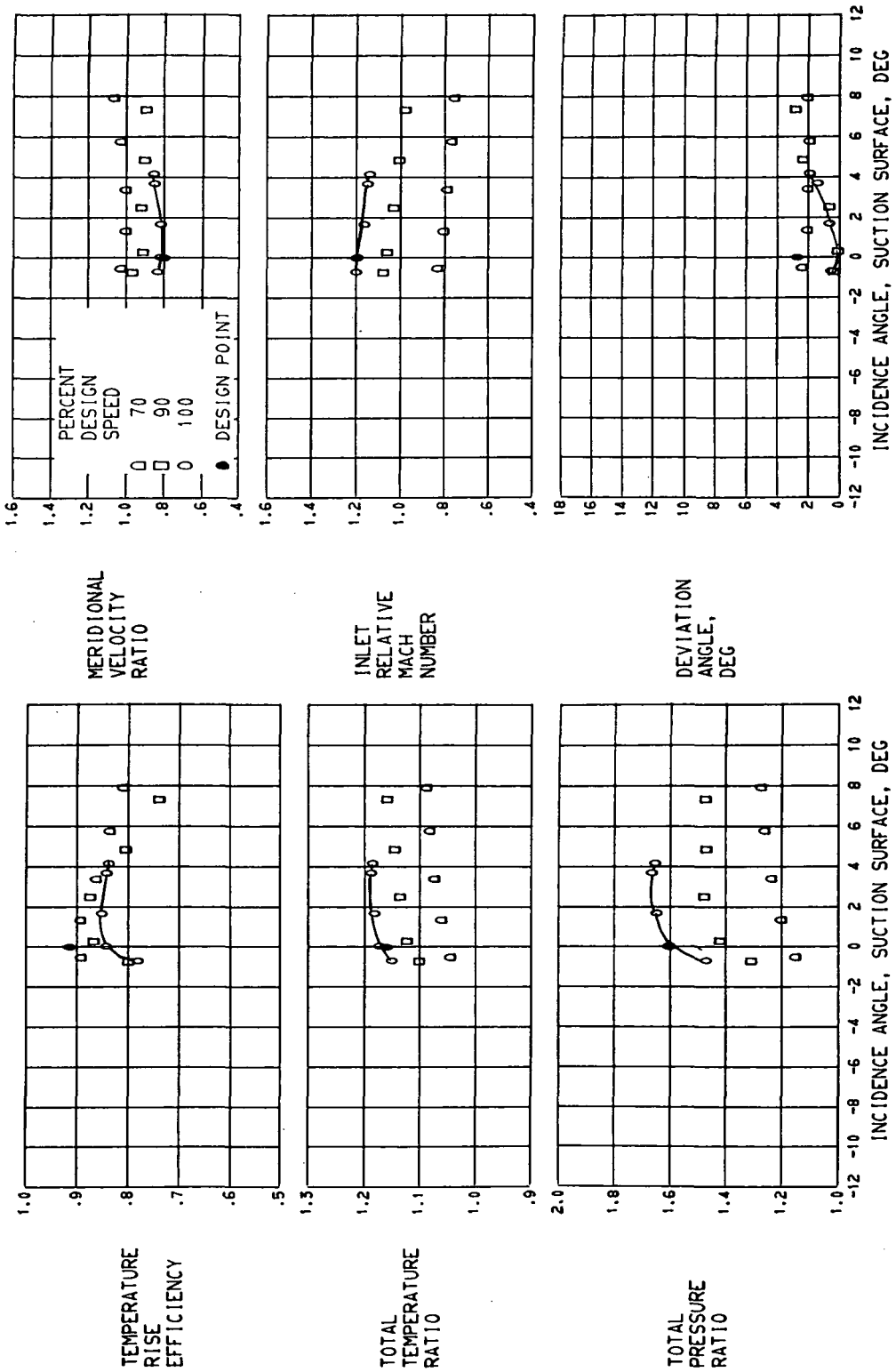

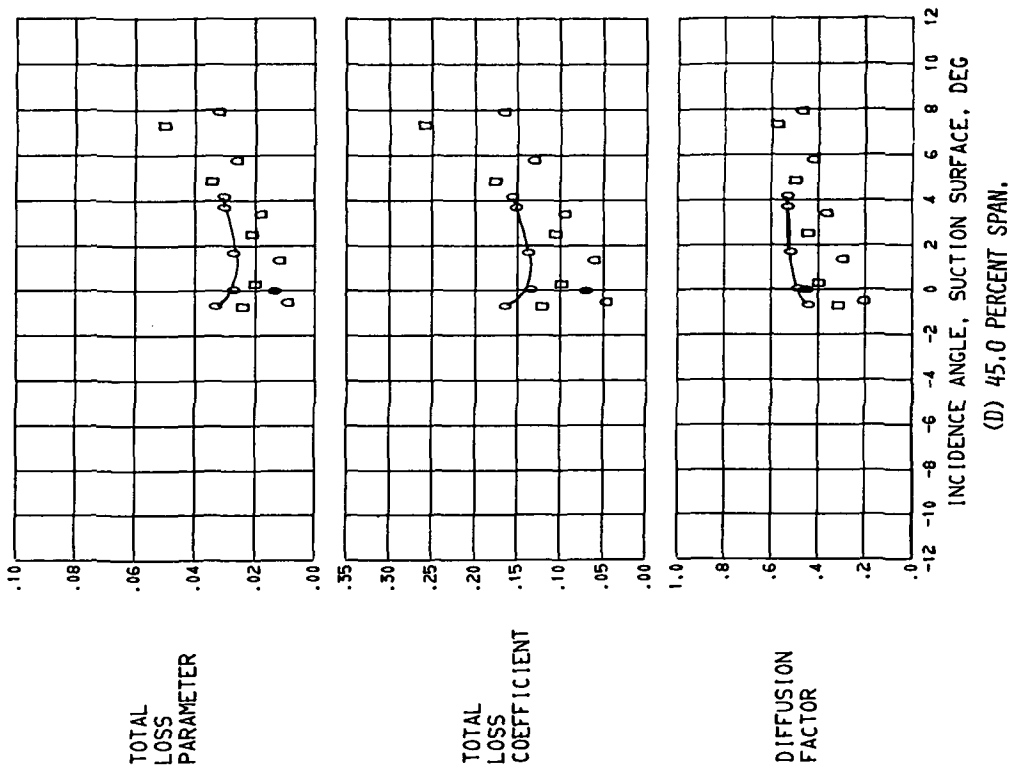
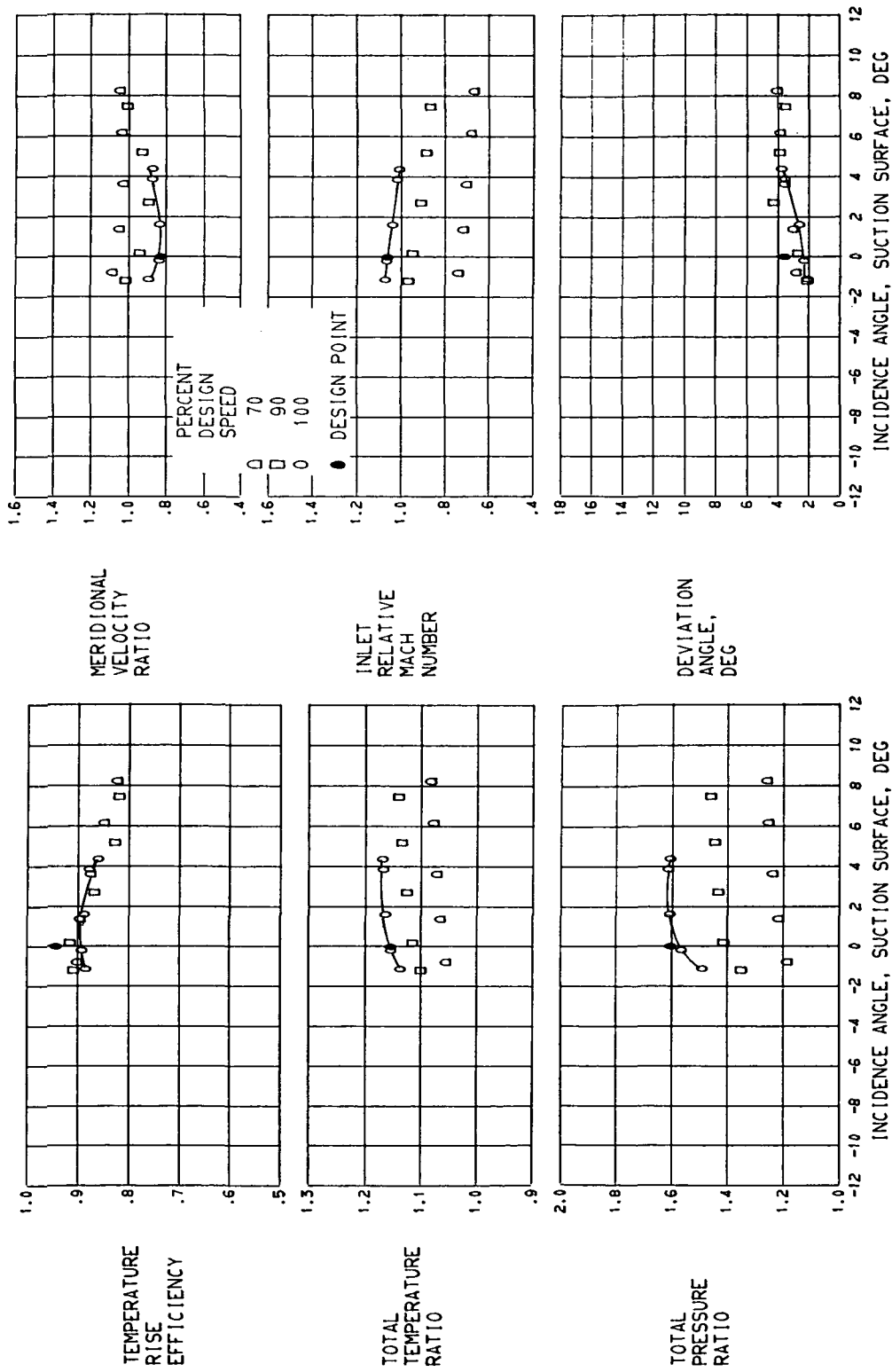
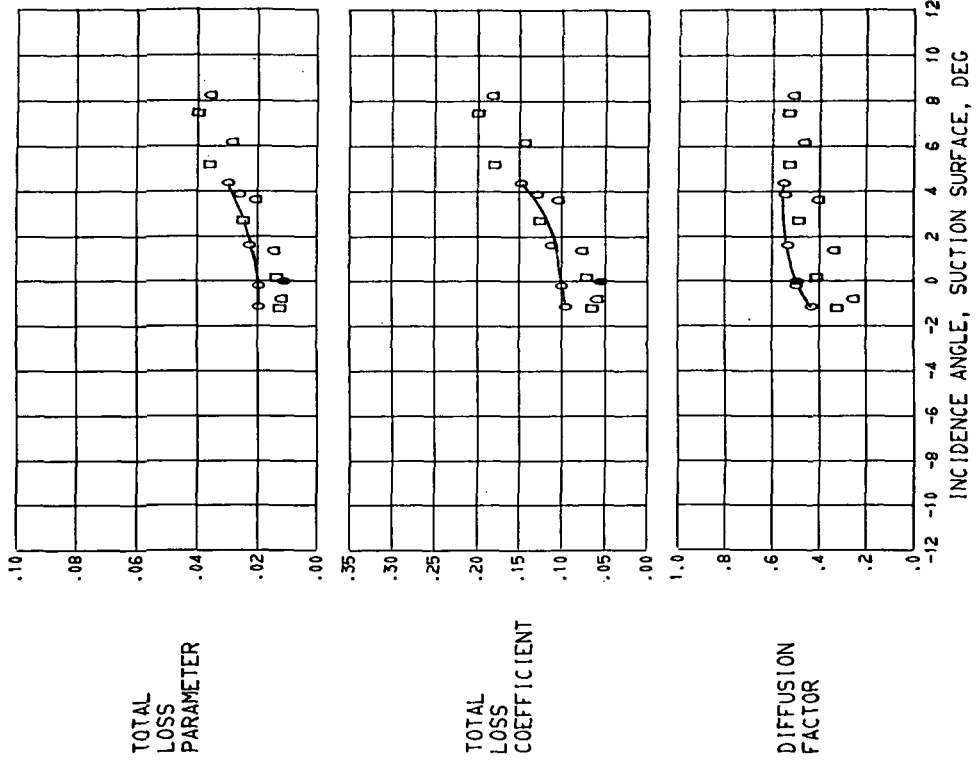

FIGURE 11. - CONTINUED. BLADE ELEMENT PERFORMANCE FOR ROTOR II.





(E) 70.0 PERCENT SPAN.

FIGURE 11. - CONTINUED, BLADE ELEMENT PERFORMANCE FOR ROTOR 11.

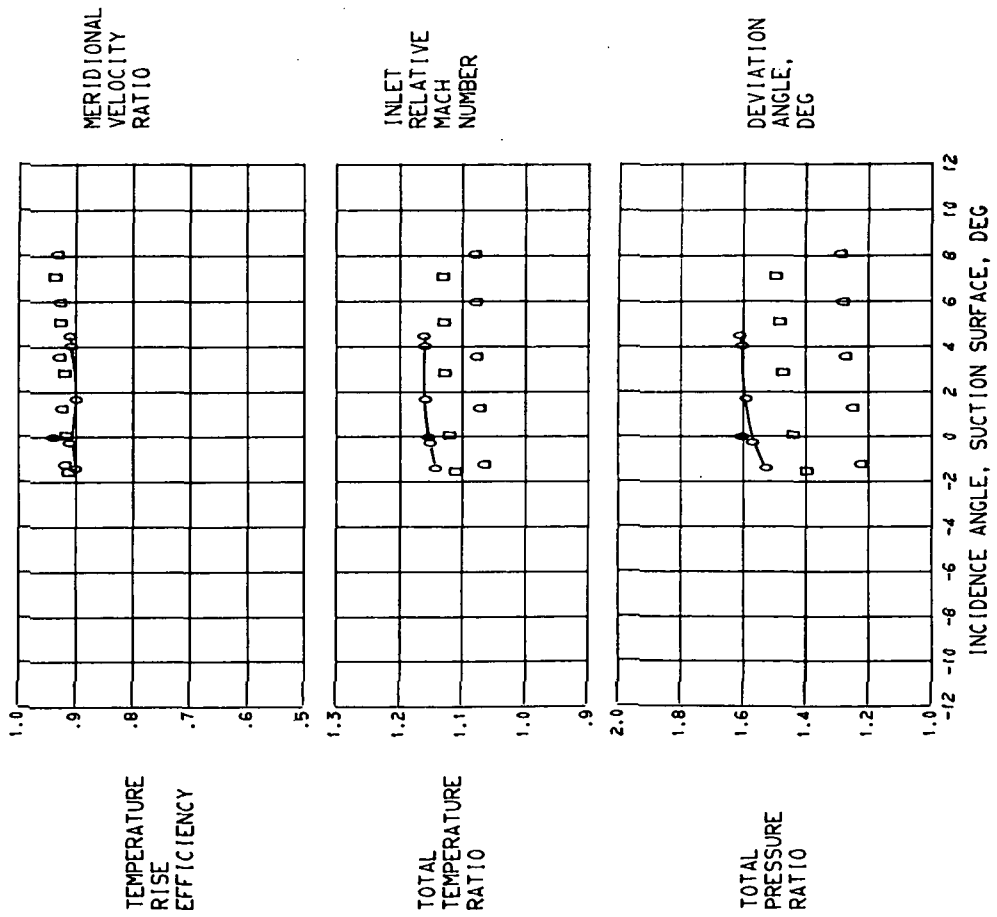
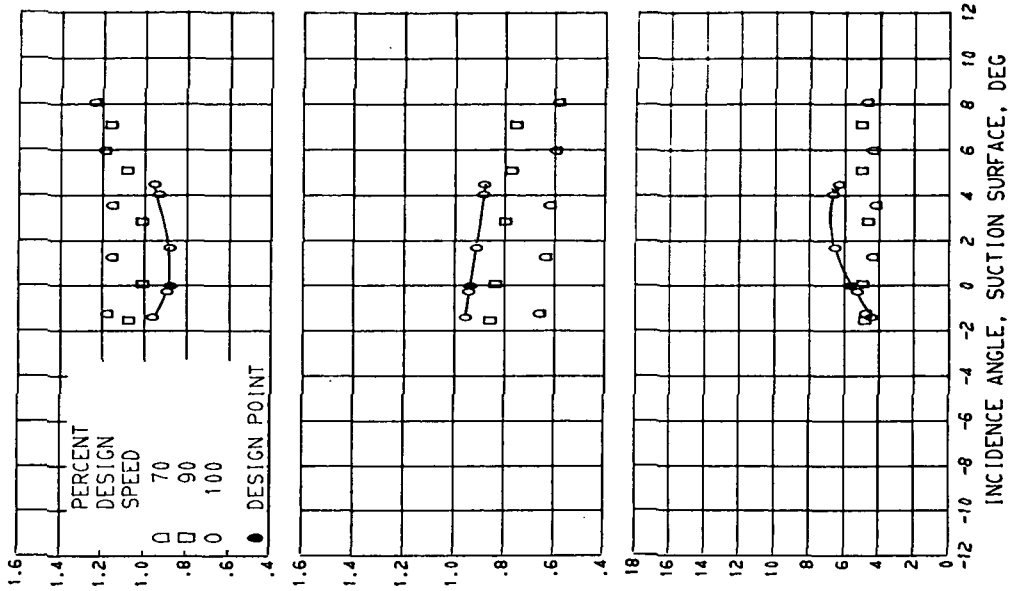

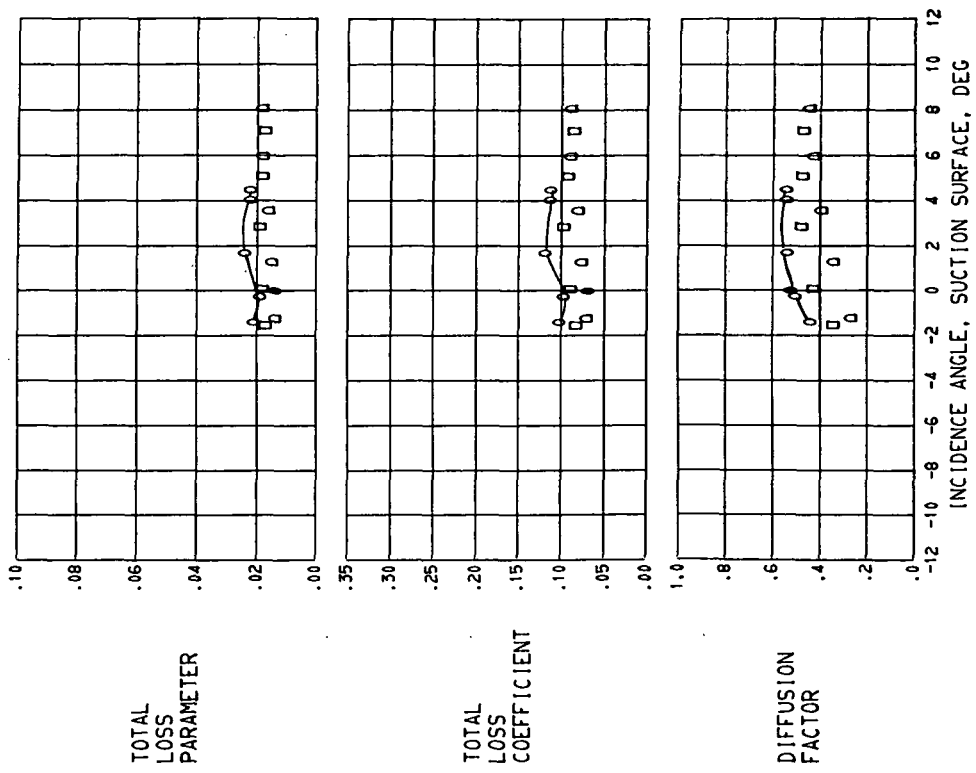

(F) 90.0 PERCENT SPAN.
 FIGURE 11. - CONTINUED, BLADE ELEMENT PERFORMANCE FOR ROTOR II.

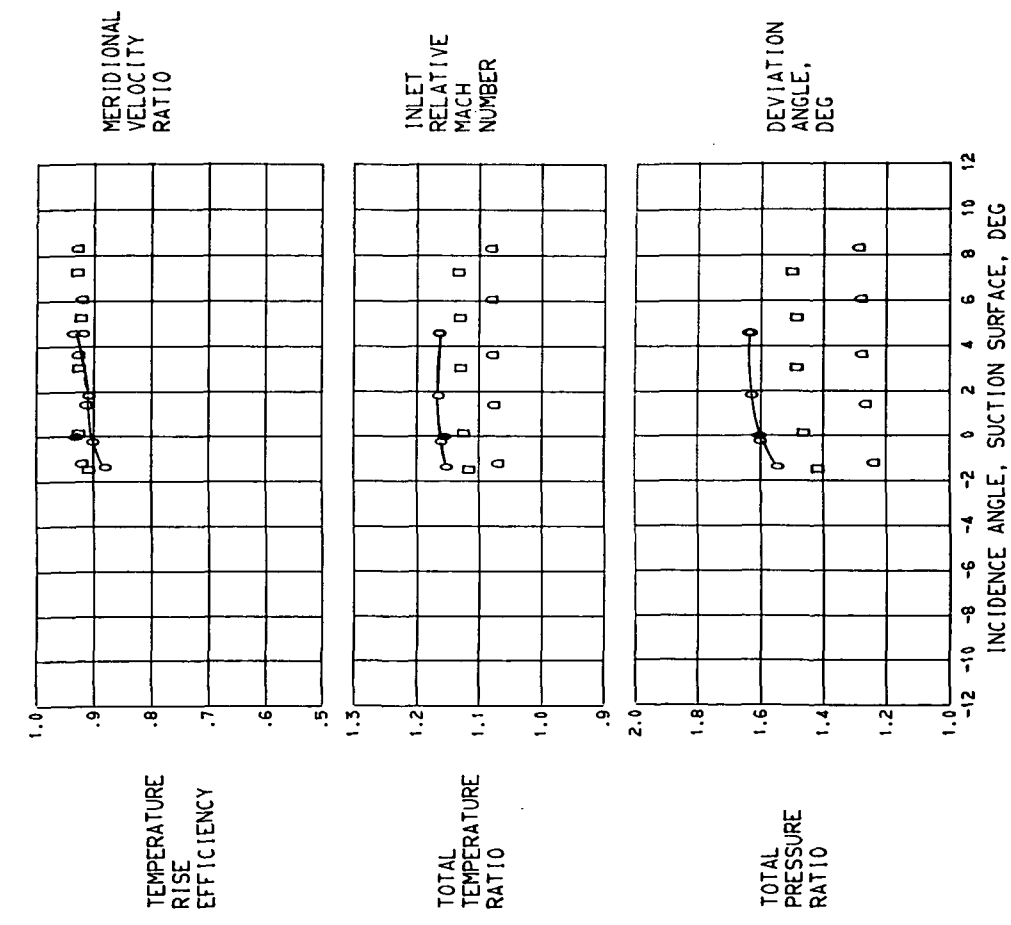
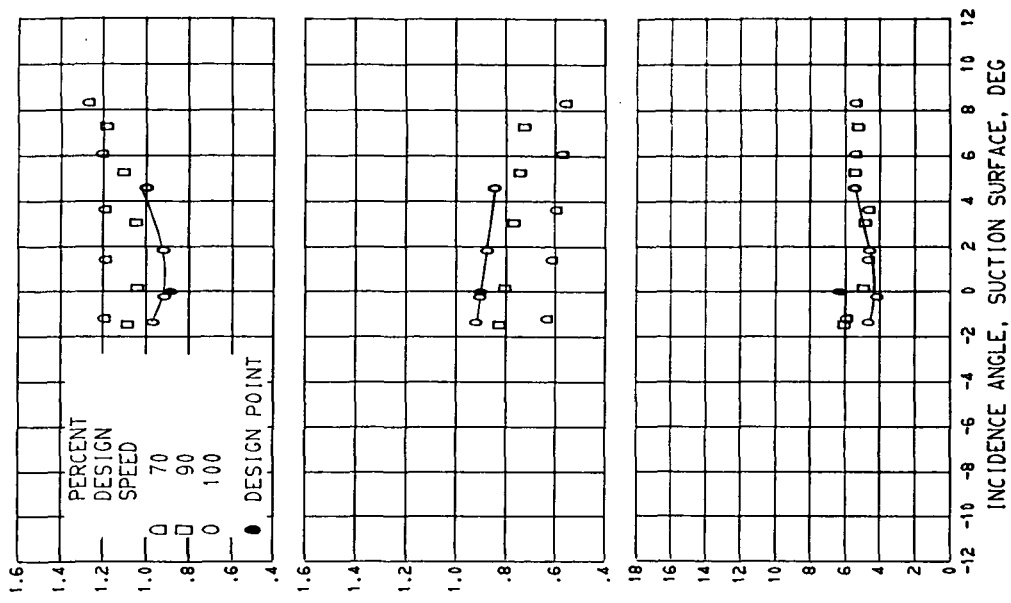

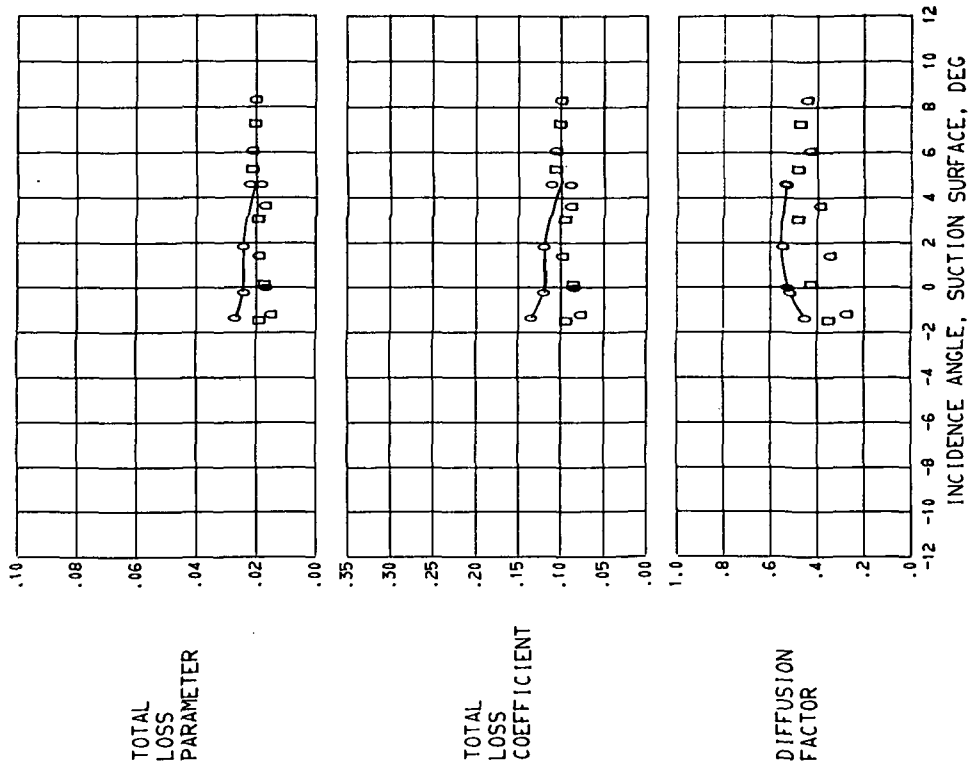
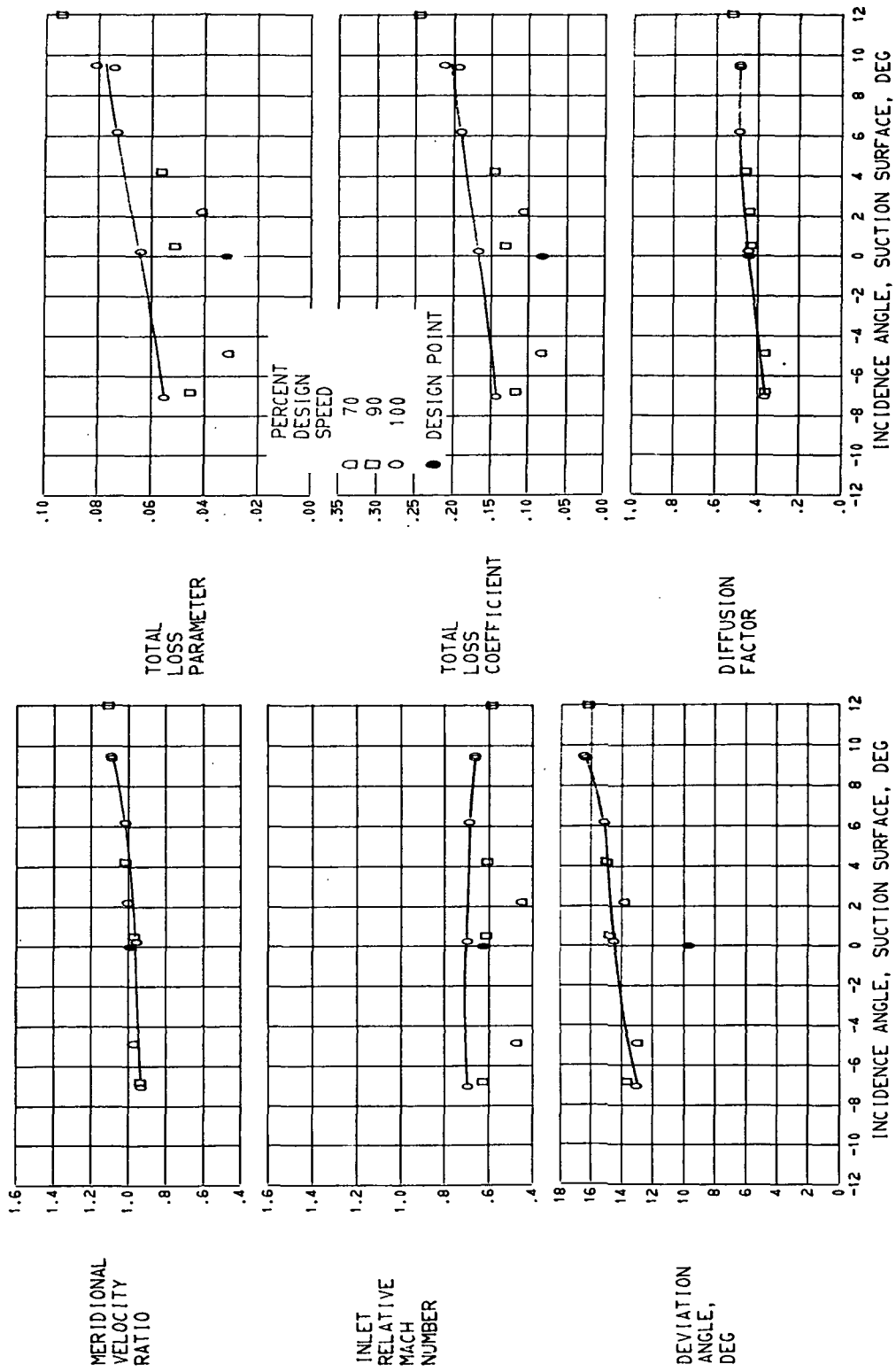
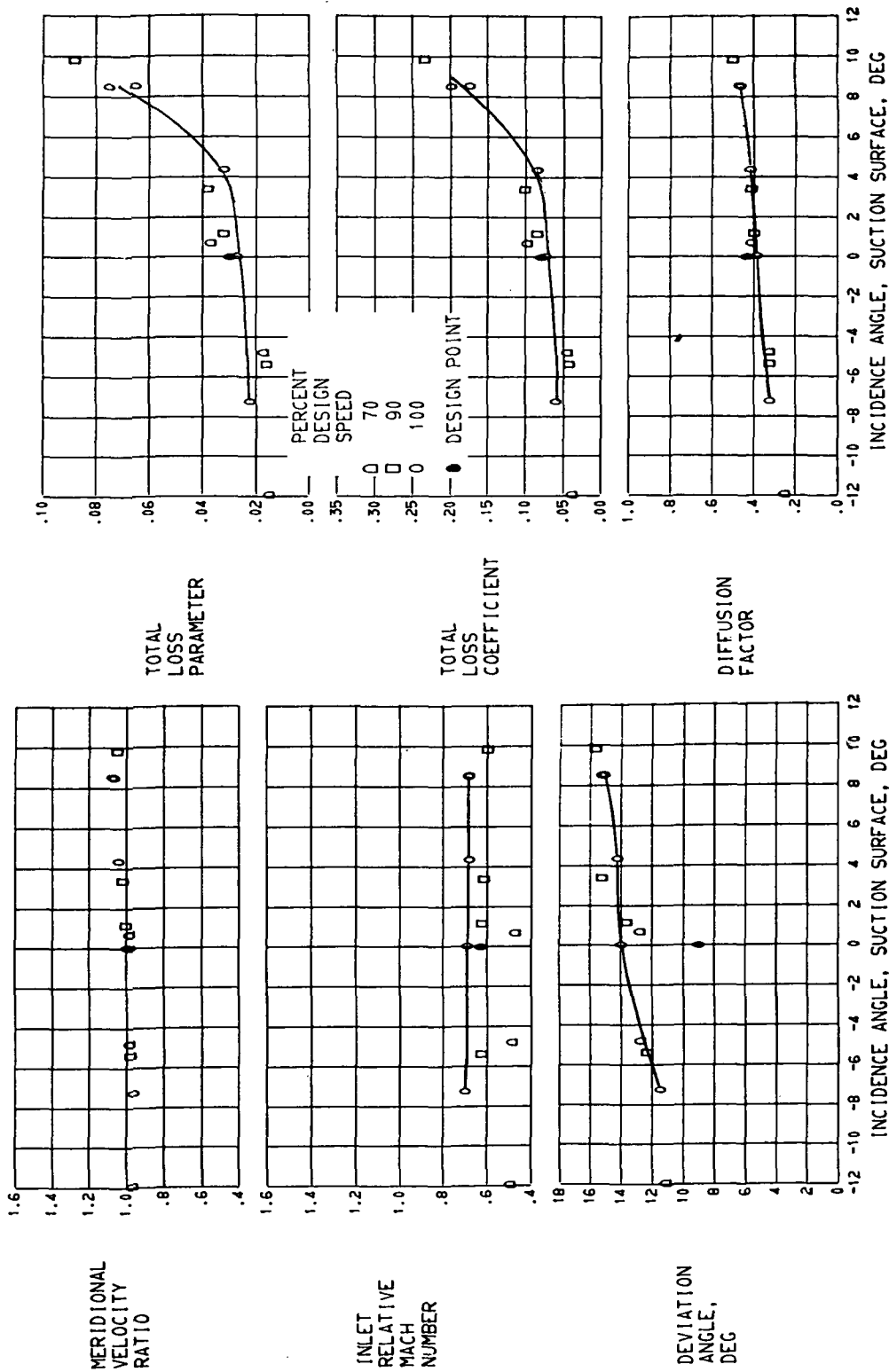

FIGURE 11. - CONCLUDED. BLADE ELEMENT PERFORMANCE FOR ROTOR II.
(G) 95.0 PERCENT SPAN.



(A) 5.0 PERCENT SPAN.

FIGURE 12. - BLADE ELEMENT PERFORMANCE FOR STATOR 4.



(B) 10.0 PERCENT SPAN.

FIGURE 12. - CONTINUED. BLADE ELEMENT PERFORMANCE FOR STATOR 4.

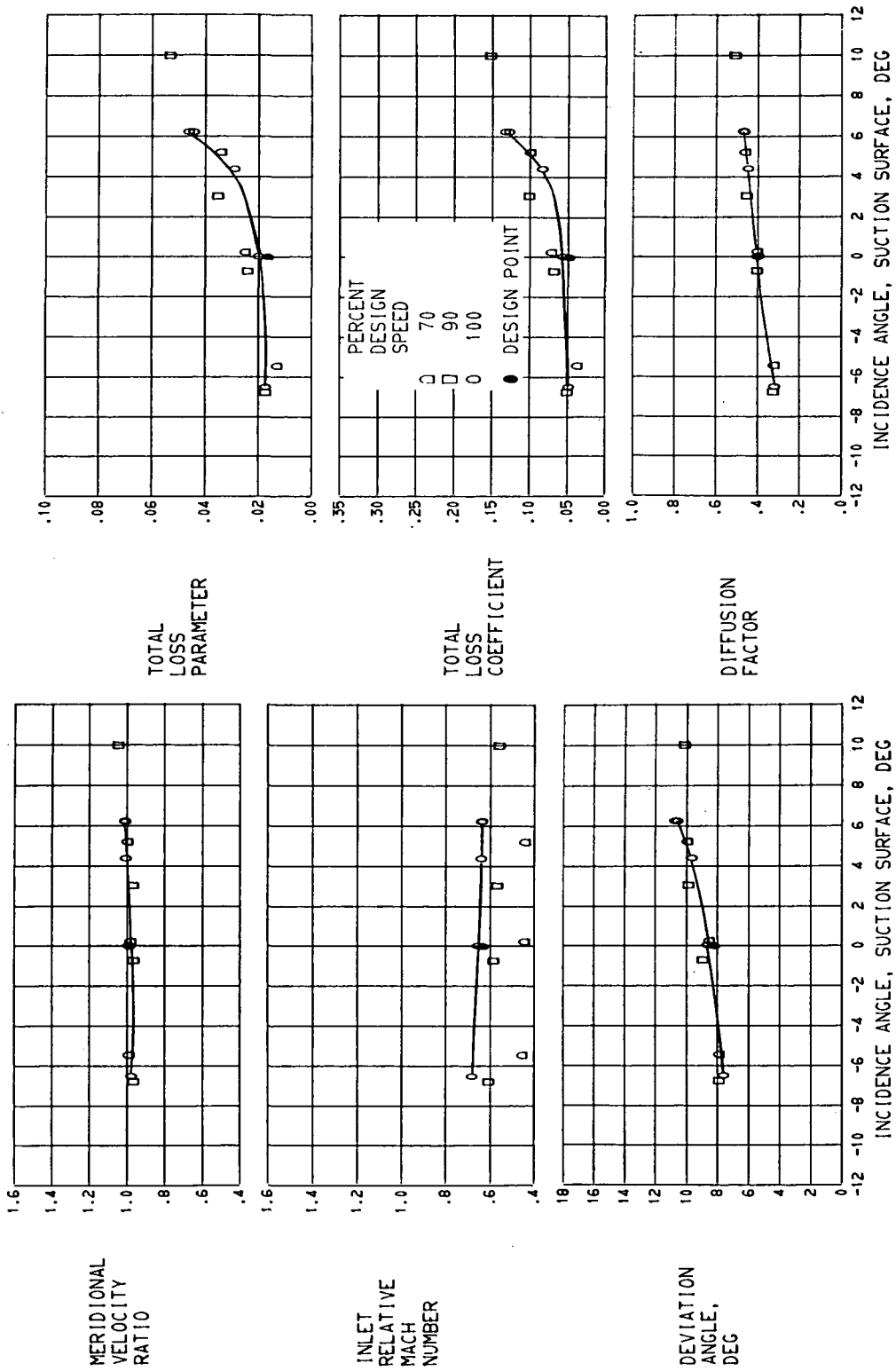

(C) 30.0 PERCENT SPAN.

FIGURE 12. - CONTINUED. BLADE ELEMENT PERFORMANCE FOR STATOR 4.

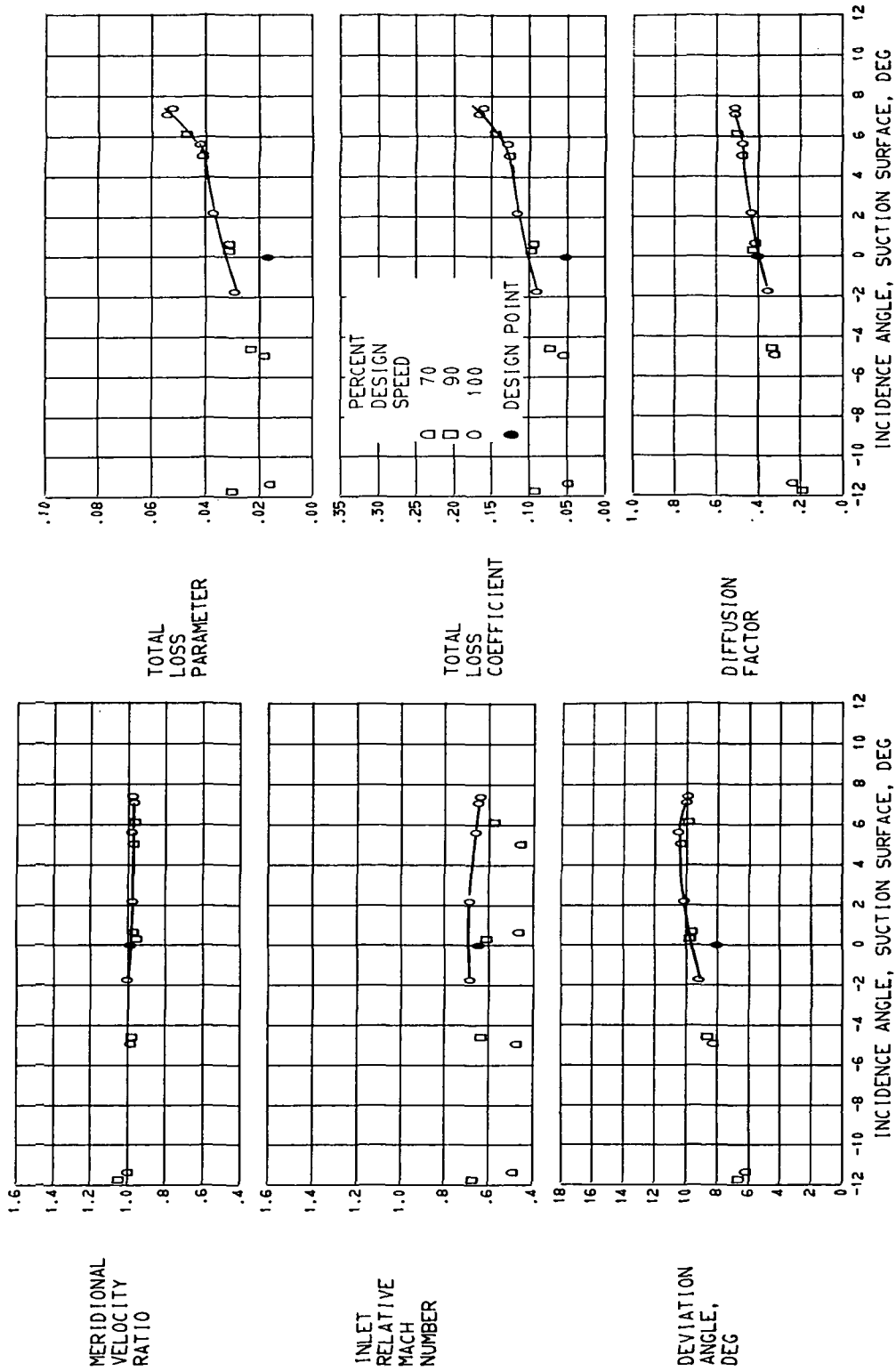

(D) 45.0 PERCENT SPAN.
 FIGURE 12. - CONTINUED, BLADE ELEMENT PERFORMANCE FOR STATOR 4.

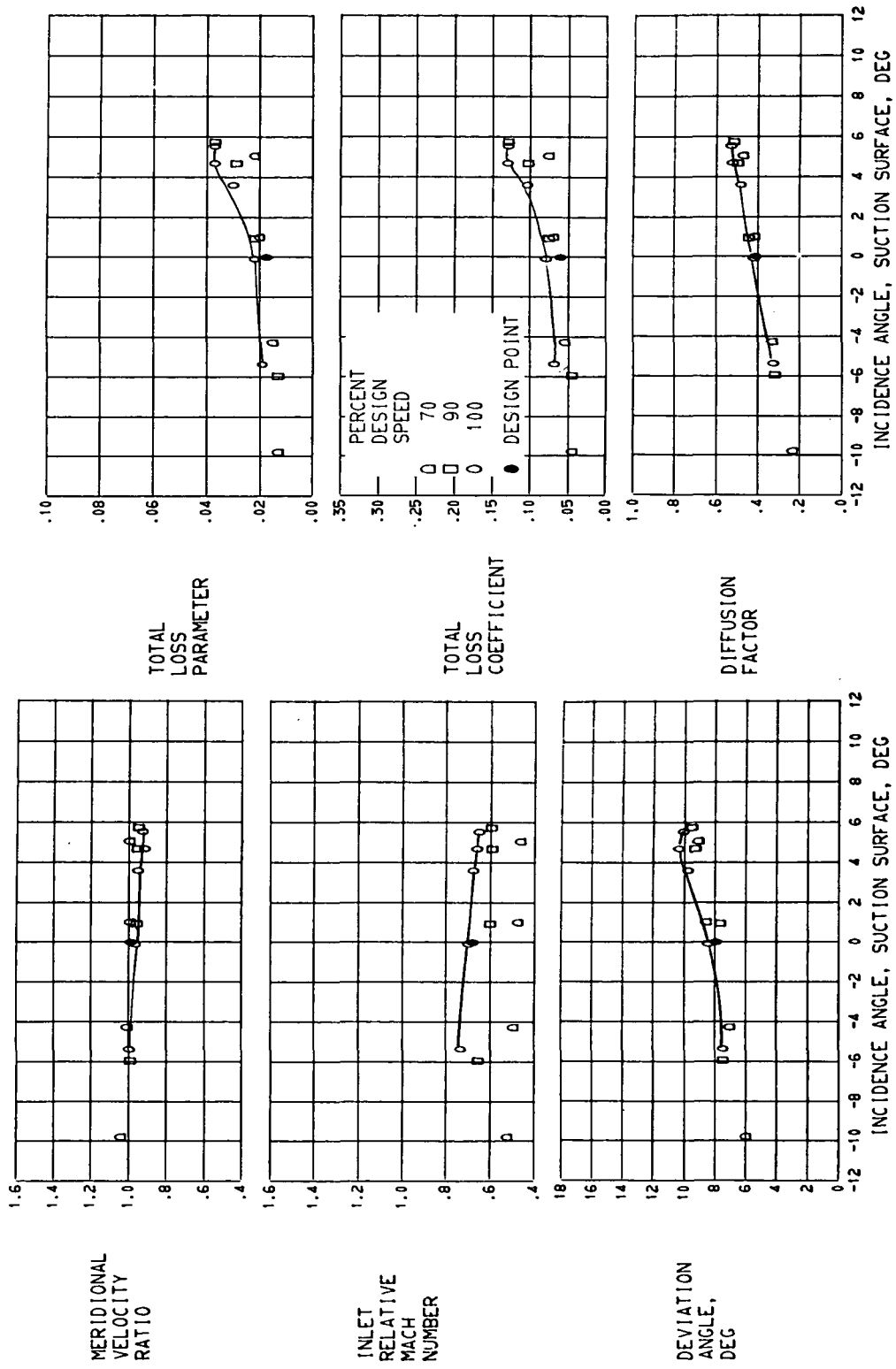

(E) 70.0 PERCENT SPAN.

FIGURE 12. - CONTINUED. BLADE ELEMENT PERFORMANCE FOR STATOR 4.

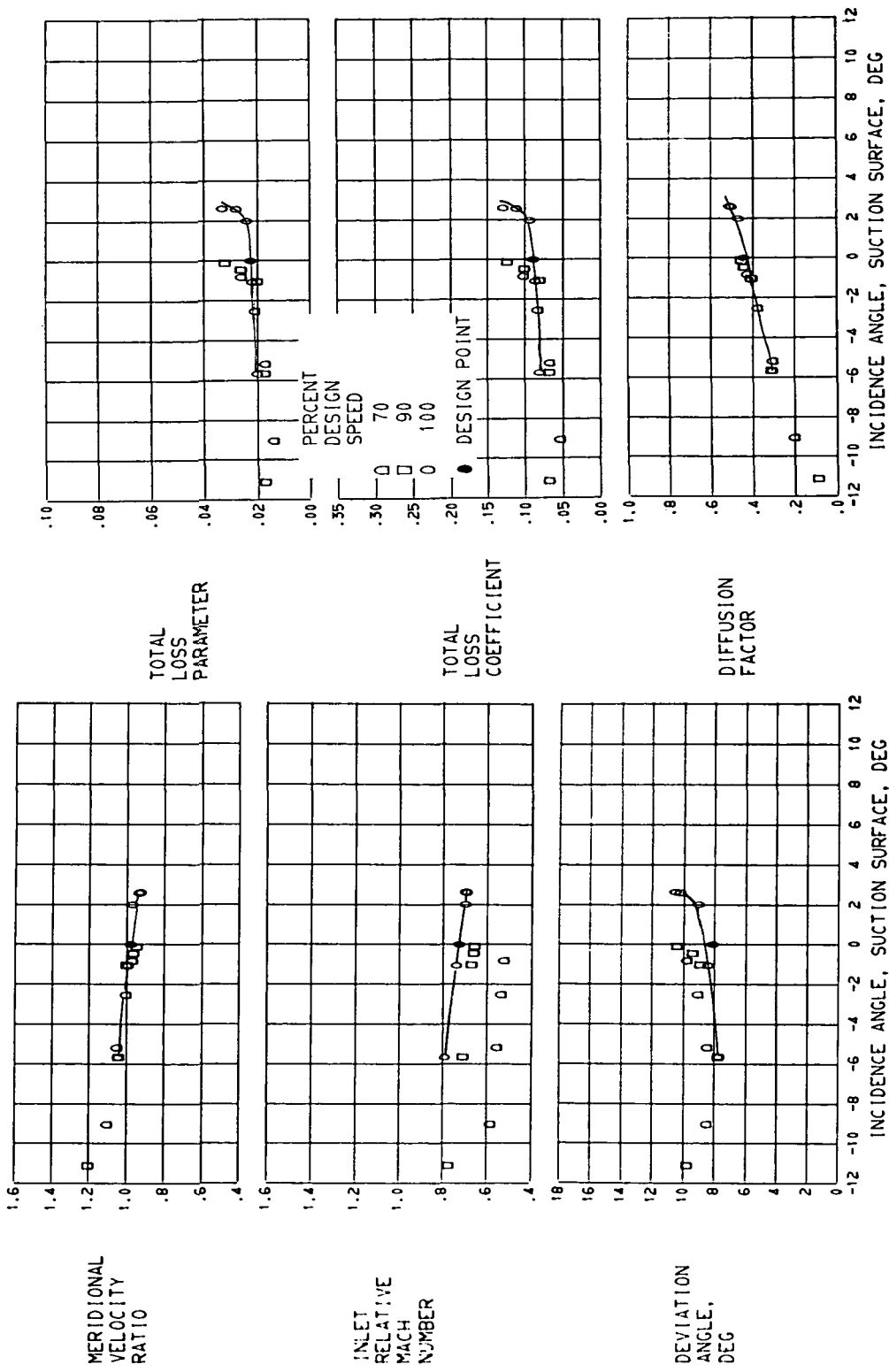

(F) 90.0 PERCENT SPAN.

FIGURE 12. - CONTINUED, BLADE ELEMENT PERFORMANCE FOR STATOR 4.

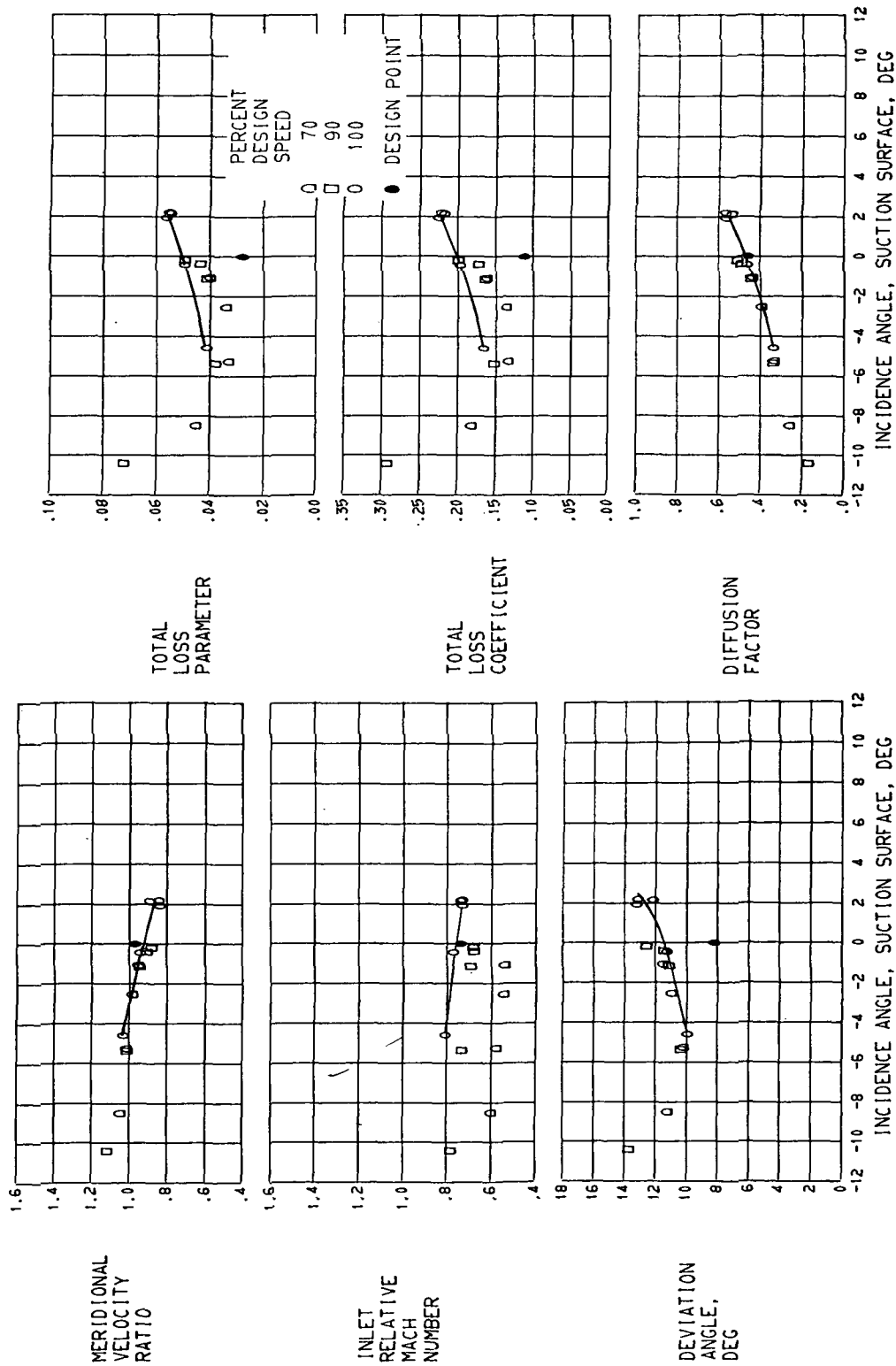

(G) 95.0 PERCENT SPAN.

FIGURE 12. - CONCLUDED. BLADE ELEMENT PERFORMANCE FOR STATOR 4.



POSTMASTER : If Undeliverable (Section 158
Postal Manual) Do Not Return

"The aeronautical and space activities of the United States shall be conducted so as to contribute . . . to the expansion of human knowledge of phenomena in the atmosphere and space. The Administration shall provide for the widest practicable and appropriate dissemination of information concerning its activities and the results thereof."

—NATIONAL AERONAUTICS AND SPACE ACT OF 1958

NASA SCIENTIFIC AND TECHNICAL PUBLICATIONS

TECHNICAL REPORTS: Scientific and technical information considered important, complete, and a lasting contribution to existing knowledge.

TECHNICAL NOTES: Information less broad in scope but nevertheless of importance as a contribution to existing knowledge.

TECHNICAL MEMORANDUMS: Information receiving limited distribution because of preliminary data, security classification, or other reasons. Also includes conference proceedings with either limited or unlimited distribution.

CONTRACTOR REPORTS: Scientific and technical information generated under a NASA contract or grant and considered an important contribution to existing knowledge.

TECHNICAL TRANSLATIONS: Information published in a foreign language considered to merit NASA distribution in English.

SPECIAL PUBLICATIONS: Information derived from or of value to NASA activities. Publications include final reports of major projects, monographs, data compilations, handbooks, sourcebooks, and special bibliographies.

TECHNOLOGY UTILIZATION PUBLICATIONS: Information on technology used by NASA that may be of particular interest in commercial and other non-aerospace applications. Publications include Tech Briefs, Technology Utilization Reports and Technology Surveys.

Details on the availability of these publications may be obtained from:

SCIENTIFIC AND TECHNICAL INFORMATION OFFICE

NATIONAL AERONAUTICS AND SPACE ADMINISTRATION
Washington, D.C. 20546