

**NASA TECHNICAL  
MEMORANDUM**

NASA TM X- 71469

NASA TM X- 71469

**ATMOSPHERIC CONSTITUENT MEASUREMENTS  
USING COMMERCIAL 747 AIRLINERS**

by Porter J. Perkins and Gregory M. Reck  
Lewis Research Center  
Cleveland, Ohio 44135

TECHNICAL PAPER proposed for presentation at  
Second Joint Conference on the Sensing of Environmental Pollutants  
sponsored by the Instrument Society of America  
Washington, D.C., December 10-12, 1973

ATMOSPHERIC CONSTITUENT MEASUREMENTS USING  
COMMERCIAL 747 AIRLINERS

Porter J. Perkins and Gregory M. Reck  
Lewis Research Center  
Cleveland, Ohio

ABSTRACT

NASA is implementing a Global Atmospheric Monitoring Program to measure the temporal and spatial distribution of particulate and gaseous constituents related to aircraft engine emissions in the upper troposphere and lower stratosphere (6 to 12 Km). Several 747 aircraft operated by different airlines flying routes selected for maximum world coverage will be instrumented. The initial design of the system (location of equipment, aircraft interfaces, etc.) was conceptually defined in feasibility studies conducted by several airlines and an airframe company. An instrumentation system is now being assembled and tested and is scheduled for operation in airline service in late 1974. Specialized instrumentation and an electronic control unit are required for automatic unattended operation on commercial airliners. An ambient air sampling system was developed to provide undisturbed outside air to the instruments in the pressurized aircraft cabin. The data system has a flight data acquisition unit and tape recorder used in late model airliners. The inertial navigation system and air data system available on the newer jets will record the location and time of the atmospheric measurement as well as meteorological information such as wind speed and direction and air temperature.

INTRODUCTION

A NASA Program is underway to equip several commercial 747 airliners with special instrument systems to routinely obtain and record-in-situ measurements of several minor atmospheric constituents on a global basis. This paper describes the environment for the instruments, the data acquisition system for airliners, and the instrument improvements and modifications needed for automatic unattended operation on commercial airliners. Only existing atmospheric constituent measurement techniques are being used for this program.

The continuing concern regarding the effects of aircraft engine exhaust emissions on the natural troposphere and stratosphere indicates the necessity for obtaining reliable data on the background concentrations of a number of minor atmospheric constituents. Potentially harmful effects of several aircraft engine exhaust constituents including oxides of nitrogen, water vapor, and

particulates have been suggested<sup>(1)</sup>. However, the actual effects of these constituents cannot be assessed without reliable atmospheric models and accurate knowledge of natural background levels.

Work has been underway for several years in the Climatic Impact Assessment Program of the Department of Transportation to collect data for verification of and input to atmospheric models related to the stratosphere. A number of universities and federal agencies have participated in this program by collecting data from rocketsondes, balloons, dedicated aircraft and ground and satellite stations using both in-situ and remote sensors. However, only a limited effort has been directed at the upper troposphere and the lower stratosphere. This region is of particular interest and importance because of the large quantities of exhaust emissions injected by the current commercial jet fleet, the possible long (weeks to months) residence times of emissions injected into the lower stratosphere, and the uncertainty over transport, mixing, and photochemical phenomena occurring in the vicinity of the tropopause.

The Lewis Research Center is implementing a Global Atmospheric Sampling Program (GASP) to examine the atmosphere between 6 and 12 kilometers<sup>(2)</sup>. This is a major effort in current NASA aircraft programs involving atmospheric monitoring. The GASP effort centers around the use of commercial airliners as an instrument platform to collect global air quality data on a routine basis<sup>(3)</sup>. The GASP objectives during the next five years are to (1) as rapidly as possible, determine the worldwide baseline concentrations of important minor atmospheric constituents in the troposphere and lower stratosphere, (2) identify any trends which could be related to the contribution of jet aircraft to possible atmospheric contamination, (3) establish an economical system for routine collection of air quality data. The data obtained with GASP systems will be used to develop more accurate atmospheric models, evaluate the potential effect of aircraft emissions on the environment, and to identify which engine exhaust constituents are most detrimental to the ambient environment. This information will then be used to guide future aircraft engine pollution reduction research. The GASP data may also be used to verify and complement data obtained from satellites equipped with remote sensors such as the Nimbus G scheduled for launch

Superior numbers refer to similarly-numbered references at the end of this paper.

later in this decade.

The approach which NASA Lewis Research Center is using to establish an operational system includes the following steps:

1. studies by airlines and airframe manufacturers to examine the technical, operational and economical feasibility of utilizing commercial airliners to collect air quality data,
2. evaluation of a number of commercially available candidate air quality instruments for the GASP application,
3. modification of selected instruments for automatic unattended operation and for approval by the airlines and the FAA,
4. system design, fabrication, and installation,
5. certification and validation,
6. data acquisition and analysis.

This paper describes the present status of the implementation of the GASP program and specifically addresses the constraints on the system, preliminary system design, instrument selection, and required instrument modifications. Step 1 is complete. Steps 2 and 3 are underway along with the system design of step 4. Data acquisition will start in late 1974.

#### ATMOSPHERIC CONSTITUENTS AND RELATED MEASUREMENTS

A number of minor atmospheric constituents have been identified as significant with respect to the contribution of jet aircraft. Table I gives a listing of important constituents which has been compiled with the assistance of the Air Resources Laboratory of the National Oceanic and Atmospheric Administration. The table lists the particulate and gas constituents related to pollution and of interest to meteorology between 6 and 12 kilometers altitude and other measurements of the atmosphere that can be pinpointed at the time of the data taking. Table II lists the constituents selected for possible measurement in the initial airline installations, an estimate of the expected range of ambient concentrations, and the measurement principle chosen for the instrument. As noted in the Table, four constituents, ozone, water vapor, carbon monoxide, and particulates (count and size distribution) will be measured on the first two flight packages. These instruments were selected from among a group of candidate instruments on the basis of constituent priority, availability, minimum modifications, laboratory evaluation, and limited flight test results. Instruments to measure the other constituents in Table II are being evaluated in flight and laboratory tests. The system is being designed with sufficient space, power, and data handling capability to accommodate additional instruments as new or improved instruments become available to measure these or the other constituents.

In addition to the air quality data received from the instruments, a considerable quantity of additional data must be recorded to document instrument identities, system status, and

supplemental flight data. The identity of individual instruments must be recorded so that the proper calibration information can be associated with each instrument channel during data reduction. The system status data includes measurements of sample pressure, temperature, and flow as well as other signals indicating valve positions, calibration cycle, or instrument temperatures. The supplemental flight data are obtained from the aircraft data computer system, and include aircraft position, speed, altitude, wind speed, wind direction and static air temperature.

#### AIRCRAFT SELECTION AND SYSTEM ENVIRONMENT

In order to establish the technical and operational requirements and the economics of using commercial airliners as instrument platforms, feasibility studies were conducted by an airframe manufacturer and several airline companies<sup>(4)</sup>. Initially, these studies served to identify the following constraints which would be imposed on the system by airlines operation:

1. No air crew duties would be imposed beyond operation of an on/off and emergency switch.
2. No revenue space would be used.
3. Limited servicing and maintenance would be performed on a noninterference basis.
4. An FAA Supplemental Type Certificate will be required.

These constraints dictate that the instruments be adapted for remote control (by an automatic on-board sequencer) and that they be reliable for periods of up to two weeks.

After examination of a number of aircraft in the commercial fleet, the Boeing 747 aircraft was selected to carry the GASP instrument system. The selection was based on (1) availability of nonrevenue space in an accessible location common to most airline configurations, (2) a route structure adequate for global coverage, (3) availability of an Inertial Navigation Systems (INS) to provide location information and a Central Air Data Computer (CADC) to provide flight data.

A specific area (shown in figure 1) adjacent to the nose wheel well below the passenger cabin was chosen for the GASP systems. The area is accessible through hatches from either the passenger compartment or outside the aircraft. Access may also be gained from the forward cargo compartment when the compartment is empty. The aircraft avionics are located in the same area just aft of the nose wheel well.

A study of possible inlet probe positions concluded that the probe should be located on the centerline just below the nose of the aircraft (also shown in figure 1). This location is sufficiently forward to avoid spray from the nose wheel well, sample contamination by the aircraft, and the likelihood of probe damage during ground operations. In this position, the probe will not interfere with the pressure, temperature, and angle of attack sensors located along the side of

the fuselage near the nose. Also, this probe location is a relatively short distance from the instrument location.

To assist in visualizing the area in the Boeing 747 where the system will be installed, a full-scale mockup of a portion of the airframe was constructed. Figure 2 is a photograph of the mockup including a conceptual model of the GASP instrument mounting system. The model shows a group of instrument cases mounted on a set of shelves installed in the aircraft. The mockup is being used for system design and layout.

The GASP system location in the Boeing 747 shares essentially the same environment as the passenger cabin during flight. The aircraft ventilation system circulates conditioned air through the cabin, forward and down into the nose wheel well area, then aft around the aircraft avionics racks into the forward cargo area. In-flight temperature will be about the same as that in the passenger cabin and the ventilation flow will be more than adequate for heat dissipation from the GASP instruments. However, the range of storage temperatures (during overnight and preflight periods) is likely to be more extreme and could extend from  $-10^{\circ}$  to  $+50^{\circ}\text{C}$ .

The GASP location is maintained at cabin pressure during flight, however, this is less than one atmosphere and varies with altitude. Figure 3 shows the cabin pressure schedule and indicates that above 7.0 km (23,000 ft.) the cabin pressure is maintained at  $6.1\text{N/cm}^2$  (8.9 psid) above altitude pressure.

The Boeing Company vibration specifications for this location in the Model 747 are not severe and range from .025 g at 5 Hz up to 1.0 g at 1000 Hz. Mechanical shocks encountered during normal operations (landing, gusts, etc.) are considered in the structural design not to exceed 5 g's.

The feasibility studies also identified several constraints on the system and instrument operation. The system must meet safety standards established for the aircraft. No combustible or toxic gases can be carried. No flames or flammable materials are permitted. No cryogenics can be stored in the system. Although proper operation of the instruments is not required for aircraft safety, the system or instruments must not malfunction or fail in any way which could conceivably jeopardize the aircraft safety. In particular, the instruments must not generate electromagnetic interference. Instrument hold-downs, mechanical supports, and interconnects must be approved, and fire prevention techniques must be employed.

#### AIR SAMPLE FLOW SYSTEM

The air sample flow system for the GASP instrument package will provide both a pressurized and an unpressurized sample flow. A schematic diagram of the flow system is shown in figure 4. The unpressurized approach is necessary when pressurization would interfere with the constituent. However, special caution must be exercised since

small leaks in the sample lines will contaminate the sample with the higher pressure cabin air. The pressurized approach is used for less reactive constituents, particularly when the instrument sensitivity is pressure-dependent and high sensitivity is required.

The air sample enters the system through a 2.5 cm diameter stainless steel external probe. The probe is closed with a motor-driven cap during ground operations and at lower altitudes to prevent contamination (as shown in figure 4). As the aircraft ascends through 6 kilometers, the cap is withdrawn and flow is initiated. Inside the aircraft, the sample velocity is slowed as it passes through an expansion section and the flow is divided into three ducts.

Approximately 1000 std liters per minute at 12 Km or 3000 std liters per minute at 6 Km flows through a unit of several individual filters which can be sequentially exposed to collect particulate samples for subsequent laboratory composition analysis. A prototype filter assembly being developed for airliner operations is shown in Figure 5. The assembly using only 1 filter unit is being tested in a wing pod mounted on a NASA-Lewis F106 aircraft. Each filter element is enclosed within a cartridge to prevent contamination. A special actuator has been developed to insert a filter element, expose it for a period of time, retract it into its cartridge, and index to the next cartridge. The filter tube is purged with ambient air between filters. Between exposure periods and purge cycles when the unit is not in use, it is sealed with isolation valves at each end. Flowrate through the filter unit is measured with a venturi downstream of the filter. Downstream of the venturi unit the flow is discharged overboard through a flush static port in the fuselage. Laboratory techniques such as neutron activation and wet chemistry will be used for analysis of deposits on the filters. The flight investigation on the F-106 filter unit is to define the exposure cycle and to develop filter handling and analysis techniques.

A smaller portion of the inlet sample is ducted to the particle and nuclei counters. A pump downstream of the particle counter sensor maintains an unpressurized sample flow through the instrument and a mass flow meter is used to measure the flowrate. Sample pressurization would result in particle losses in the pump. A special pressure controller is being developed to supply the nuclei counter. This controller uses filtered cabin air to raise the sample pressure to an acceptable level for the operation of the condensation type nuclei counter. Both of these instruments are located as close as possible to the inlet probe to avoid impaction and electrostatic particle losses in the sample line.

The remainder of the sample flow is ducted through a separate line to the gas analyzers. The oxides of nitrogen instrument draws an unpressurized sample flow since the chemiluminescent detector is more sensitive at low pressures. Sample flow to the balance of the instruments is pressurized with

a single-stage diaphragm pump. A pressure regulation system described in ref. 5 is used to maintain a pressure of one atmosphere at the inlet manifold which supplies the various instruments. A backpressure regulator controls the inlet manifold pressure. An absolute pressure regulator which contains a sealed, evacuated bellows reference cell supplies a constant reference pressure to the dome of the backpressure regulator. Downstream of each instrument, a choked venturi establishes the instrument flowrate. Thus, the inlet manifold sample pressure is independent of pressure altitude and cabin altitude but the instrument flows are not required to pass through a regulator upstream of the instruments. The discharge flows from all the instruments are collected in a common line and exhausted overboard through the vent port. A prototype version of this pressurization system was successfully flight tested on the NASA CV-990 during three flight periods in 1972(5).

An important consideration in the design of the flow system is the component material selection. Some reactive constituents such as ozone are compatible with only a few materials and an improper choice can result in an excessive reduction in the constituent concentration<sup>(6)</sup>. For this reason, the sample lines leading from the inlet probe to the pressurization pump and all the components in the pressurized portion of the system upstream of the instruments are fabricated from Teflon or are Teflon-coated on the inside. Ozone destruction can be minimized by minimizing sample residence time, keeping the system clean, and conditioning the system with high ozone concentrations.

The schematic diagram in figure 4 indicates that the sensor for the water vapor measurement is not located in a sample flow line. Experimental work has shown that surface effects inherent with in-line installations cause excessive interference with the measurement. As a result, the sensor is located in a modified total air temperature probe mounted externally near the inlet probe. The probe is specially designed to prevent water droplets and particles from impacting the sensing elements.

Wherever possible and necessary to assure reliable data, a means of in-flight calibration is planned as shown in figure 4. The ozone instrument inlet has a bypass line containing an ozone scrubber for producing a zero gas and an ozone generator for a span check. The carbon monoxide analyzer generates a zero gas internally. Three-way valves are located in the inlet lines of most of these gas analyzers to input calibration and zero gases. A gas scrubber will be used to provide a zero gas and gas bottles or permeation tubes may be carried as span gas sources, depending on safety considerations.

A provision is also included for ground checks of the sample flow system and instruments. A vacuum pump is carried out to the aircraft and connected to the exhaust port. The ground check inlet valve is opened in lieu of the inlet probe. A

limiting orifice in the ground check line restricts the inlet flow, simulating an altitude condition, and the filter prevents system contamination.

Some instrumentation is included to verify that the flow system is functioning properly. An absolute pressure transducer (strain-gage type) will measure the inlet manifold pressure. These pressure data will be required for several instruments whose calibrations are pressure-dependent. A thermistor will be used to measure the inlet manifold sample temperature. Individual instrument flows will be determined by measuring the pressure between a fixed orifice and the choked venturi downstream of each instrument.

An additional instrument which will not be included in the early systems but may be added as it becomes available is a cloud detector. Data on the presence of clouds is helpful in identifying local meteorology and also in interpreting data from the particle counter. Entrained water droplets can interfere with the particle count data. The water vapor sensor should provide some information; but an infrared radiometer cloud detector will eventually be included to give a positive indication.

#### DATA MANAGEMENT AND CONTROL SYSTEM

One of the constraints on the GASP system imposed by the airlines is that the system must not interfere with or place any additional duties on the flight crew, which leads to the requirement for automatic unattended operation. A schematic diagram of the data acquisition, management, and control system which provides this capability is shown in figure 6.

The heart of the system is the data management and control unit (DMCU) which is specifically designed for the GASP system. It contains the programming necessary to automatically direct the activity of the system. However, a manual override is provided for operation during ground checkout and flight validation tests. During manual operation, the system is directed and monitored from a control and display panel located in the cockpit during the flight validation tests or in later installations located in a ground checkout console.

There are essentially three modes of operation: standby; calibration; and data. During standby operation, power is available and portions of the system are warming up; however, the sample flow system is not operating and data are not recorded. The system is in the standby mode at least one hour before initial calibration begins. The calibration mode of operation is cyclical. It consists of 5 minutes each of (1) zero gas and outside air purge, and (2) span gas flows. The system performs a calibration cycle as frequently as determined necessary which could be at the beginning and end of the data portion of each flight as well as periodically during the data portion. The calibration data are recorded and used in data reduction. The system begins the data mode of operation when the aircraft

climbs through 6 kilometers and after the initial calibration cycle is completed. Data are recorded at 10 minute intervals (except when necessary during calibration cycles) until the aircraft descends through 6 kilometers.

A number of programmable functions are available for automatic control. These include the timing of the calibration and data modes and sequences and of data acquisition during these modes. Altitudes for inlet probe opening and closing and initiation of filter exposure are programmable as well as the filter exposure interval.

In addition to its other control functions, the DMCU also manages the data flow between the Flight Data Acquisition Unit (FDAU) and the data recorder. The FDAU is essentially a standard data handling and conditioning unit used extensively on late model airliners. It accepts the output signals from the air sampling instruments, the flow system instruments, and the Central Air Data Computer (CADC). On command from the DMCU, it supplies these data to the recorder. The FDAU cannot couple directly to the Inertial Navigation System (INS) input but requires an INS interface unit and conditioning equipment in the DMCU. The INS data contains latitude, longitude, windspeed, and wind angle. The FDAU can couple directly to the CADC to receive altitude, airspeed, and static air temperature data. The FDAU is capable of processing d.c. analog, digital, and synchro signals and converting the analog and synchro signals to digital signals.

The data recorder is also a standard cassette-loaded serial-digital tape recorder used on today's airliners. The recorder capacity is established on the basis of a 14-day mission with system expansion to include up to 10 air sampling instruments. The use of this recorder requires a ground-based transcriber to translate the serial digital data tape into a computer-compatible digital tape.

#### INSTRUMENT DESCRIPTION

The instruments used for the measurements of the atmospheric constituents given in Table II are either being modified or are under serious consideration for eventual inclusion in airline 747 GASP systems. The first four instruments have been selected to be included in the first two GASP systems. A brief description of the operating principle and unique features of each of these four instruments is given below.

#### Ultraviolet Absorption Ozone Monitor

This instrument alternately passes the sample gas and then an ozone-free zero gas (obtained by passing sample gas through an ozone destruction filter) through a 71 cm long tube and measures the difference in intensity of an ultraviolet beam traversing the same path length. The difference is converted into ozone mixing ratio. The instrument employs a reference system which compensates for variations in the optical components, interfering gases, and variations in the

ultraviolet source<sup>(7)</sup>.

#### Aluminum Oxide Hygrometer

This instrument consists of two parts: a sensing element and an electronics package. The sensing element is a small strip of aluminum which is anodized by a special process to provide a porous oxide layer. A very thin coating of gold is evaporated over this structure. The aluminum base and the gold layer form the two electrodes of a capacitor. The amount of water adsorbed on the oxide layer determines the conductivity of the pore wall which becomes a measure of the water vapor<sup>(8)</sup>.

#### Fluorescent Carbon Monoxide Monitor

This instrument is a single-beam non-dispersive infrared absorption analyzer<sup>(9)</sup>. A source alternately irradiates two gas cells mounted on a rotating wheel. Each gas chamber contains a carbon monoxide gas mixture which then fluoresces into the sample tube and the transmitted beam intensity is measured at the opposite end of the tube. One of the gas cells contains a common isotope of CO while the other contains a rare isotope. The ratio of transmitted intensities can be converted to CO mixing ratio. This instrument has a particularly stable span concentration although it is sensitive to changes in the ambient temperature. A heated Hopkalite filter is included in the instrument to produce a zero gas for in-flight calibration.

#### Light-scattering Particle Counter

This instrument consists of two parts: (1) a sensing package which handles the sample flow and contains the light source, optics, and a photomultiplier tube, and (2) an electronics package which includes pulse height discriminating and counting circuits<sup>(10)</sup>. Each particle larger than 0.5 microns scatters light from the source as it passes through the sensor which is focused to pick up the forward scattered light on the photomultiplier tube. The height of the resulting pulse is proportional to the particle diameter and the pulse train from the tube is discriminated and counted to yield a size distribution.

#### Instrument Modifications

Since most of the instruments selected for the GASP system have not been designed for operation in aircraft, or remote or automatic control, a number of modifications are required to adapt the instruments to the system and to the environment.

The first requirement is that the instruments must be repackaged for mounting in the aircraft. A number of considerations were involved in selecting a package design. The case must be capable of supporting instruments weighing up to 50 lbs. at the specified shock and vibration levels. The cases should be somewhat uniform and easily replaceable. In particular, it is desirable that the case design be familiar to the

airlines. The standardized "ATR" case and the support structure which are used for much of the avionics on commercial jetliners were selected. The ATR case and the supporting rack have been standardized by the Aeronautical Radio Incorporation and they are available in a variety of dimensions. Photographs of a typical ATR case and its insertion in a hold-down rack are shown in figure 7. As is shown the ATR case is easily handled and can be quickly removed and replaced. Electronics for input and output are provided by a connector on the rear of the case. Plumbing connectors for sample flow, a circuit breaker, and a rotameter to indicate instrument flow will be installed on the front face of the ATR case.

The electrical power available on the Boeing 747 resulted in modifications of most of the instruments. A 400 Hertz, 115 volt system is the primary power supply. For most instruments, only minor modifications were necessary although most motors had to be replaced.

The requirement for remote control resulted in only a few modifications to several instruments. Several solenoid valves and relays were installed for flow and instrument control. A thermistor was installed in each instrument case to protect against overheating.

Two resistors were installed in each instrument and their values are recorded along with sampling data on the data tape for identification purposes. This permits individual calibration curves for various models of a given instrument to be stored in the data reduction program. When an instrument consists of two or more separate packages, a corresponding number of identification channels will be established and the performance record of each unit will be traceable.

#### TESTING AND CERTIFICATION REQUIREMENTS

The feasibility studies determined that addition of the GASP system to 747 airline aircraft presented a substantial modification to the aircraft and that a Supplemental Type Certificate (STC) from the FAA would be required. This certification of the GASP system will involve several elements. The system design and operation must be thoroughly documented, including a detailed failure analysis. Then ground and flight test programs must be developed and performed. The STC may then be granted on the basis of the documentation, an inspection of the system installation, and successful flight test results.

The ground tests will consist of a series of environmental tests followed by a series of system tests. Detailed environmental test procedures for electrical and electronic equipment intended for commercial jet aircraft have been established by the Radio Technical Commission for Aeronautics<sup>(11)</sup>. The Boeing Company has also developed environmental test specifications for the Model 747 airplane. The following group of environmental tests are

pertinent to the GASP system:

1. Temperature and Altitude. This series of tests includes hot and cold soaks, operating temperature extremes, temperature variations, pressure variations, and decompression.
2. Vibration. This test procedure involves three types of tests; a preliminary sinusoidal scan of the vibration envelope, a period of dwell on the four worst resonances located during the scan, and sinusoidal sweeps through the envelope.
3. Shock. Two tests are required; an operating shock test after which the equipment should perform within specifications, and then a crash shock test with dummy components to verify the mechanical integrity of the case.
4. Humidity. High relative humidities are maintained with the highest operating temperature for several days.
5. Power Input. The power supply frequency and voltage is varied over specified ranges, then the instrument response to voltage transients is examined.
6. Electromagnetic Compatibility. The equipment is examined for both radiated and conducted susceptibility and interference.

The GASP system equipment is in an unusual aircraft operational situation insofar as no aircraft systems rely on its operation. A malfunction or failure of a GASP instrument will have no effect on aircraft operation or safety, and can only result in erroneous sample data. Viewed in this light, the only significant environmental tests are the shock and vibration tests which show that the equipment will not come loose, and the electromagnetic interference tests which verify that the system will not affect the aircraft instruments. However, since NASA is interested in retrieving valid data and minimizing loss of data due to instrument failure between check periods, one of each of the instruments will be subjected to the extent possible the full complement of environmental tests.

Following the environmental tests which will primarily involve components, the system will be assembled and checked through its various modes of operation. Various failures will be simulated to ensure appropriate system response.

Three sets of flight tests will be performed. A series of flights on the NASA CV-990 based at Ames Research Center will demonstrate system operation in a flight environment and system compatibility with other aircraft systems. Also, an attempt will be made to obtain comparison sampling data from other sensors operating from other platforms. Next, the system will be installed, inspected by FAA, and flight tested on a Boeing 747 airplane. No more than one flight test should be required. Finally, the

system will be closely observed for a three-month validation period during which the aircraft will be in routine commercial airline service. NASA will follow the first GASP system closely for this initial three-month validation period. During this period, an observer will accompany the system on most routine commercial flights and monitor its operation with the control and display panel in the cockpit. The output data will also be scrutinized on a daily basis.

#### CONCLUDING REMARKS

A program to determine the temporal and spatial distribution of minor atmospheric constituents associated with gaseous and particulate pollutants in the upper troposphere and lower stratosphere (6 to 12 Km) is currently being implemented by NASA. Continuous measurements will be obtained from several instrumented 747 airliners in commercial service. Those constituents affecting air quality that are related to aircraft engine exhaust emissions will be measured.

Feasibility studies established certain constraints imposed by airline operations on a non-interference basis. The measurement system requires no duties of the air crew, no use of revenue space, and no servicing or maintenance that would interfere with routine operations. Because a significant modification to the aircraft is required, an FAA Supplemental Type Certificate (STC) of airworthiness must be obtained. A completely automatic system to meet these requirements is being designed and fabricated. Instruments were selected on the basis of suitability for this application and are being modified and tested to comply with FAA and airline requirements.

Considerable effort is required to obtain data automatically on commercial airliners. Instruments designed for use on the ground must be modified and systems must be built to collect and control outside ambient air. Nevertheless the concept will provide large quantities of data on a world-wide basis much less expensively than could be obtained from dedicated aircraft.

#### REFERENCES

- (1) Johnston, H., "Reduction of Stratospheric Ozone by Nitrogen Oxide Catalysts from Supersonic Transport Exhaust," Science, Vol. 173, No. 3996, Aug. 6, 1971, pp. 517-522.
- (2) Rudey, Richard A., and Perkins, Porter J.: "Measurement of High-Altitude Air Quality Using Aircraft," Paper 73-517, June 1973, AIAA New York, New York.
- (3) Steinberg, Robert: "Role of Commercial Aircraft in Global Monitoring Systems," Science - Vol. 180, No. 4084, April 27, 1973. pp. 375-380.
- (4) Stepka, Francis S., and Perkins, Porter J.: "Use of Commercial Air Transports for Atmospheric Constituent Sampling," Proposed NASA TN.

- (5) Reck, Gregory M., Briehl, Daniel, Perkins, Porter J.: "Flight Tests of a System to Measure Minor Atmospheric Constituents from an Aircraft," Proposed NASA TN.
- (6) Altshuller, A. P., and Wartburg, A. F., "The Interaction of Ozone with Plastic and Metallic Materials in a Dynamic Flow System," International Journal of Air and Water Pollution, Vol. 4, Nos. 1/2, 1961, pp. 70-78.
- (7) Bowman, L. D., and Horak, R. F., "A Continuous Ultraviolet Absorption Ozone Photometer," Instrument Society of America, AID 72430, 1972, pp. 103-108.
- (8) Goodman, P. and Chleck, D.: "Calibration of the Panometrics Aluminum Oxide Hygrometer," Analysis Instrumentation, (7) 1969, p. 233.
- (9) Link, W. T., McClatchie, E. A. Watson, D. A., and Compher, A. B.: "A Fluorescent Source NDIR Carbon Monoxide Analyzer," Paper 71-1047, Nov. 1971, AIAA, New York, New York.
- (10) Joenicke, R., "The Optical Particle Counter: Cross-Sensitivity and Coincidence," Max Planck - Institut Fur Chemie, Mainz, Germany and National Center for Atmospheric Research, Boulder, Colorado, 1973.
- (11) RTCA SC-112, "Environmental Conditions and Test Procedures for Airborne Electronic/Electrical Equipment and Instruments," Document No. DO-138, Radio Technical Commission for Aeronautics, Washington, D. C. June 1968.



E-7770

TABLE I. - ATMOSPHERIC CONSTITUENTS AND RELATED MEASUREMENTS OF INTEREST  
IN NASA GLOBAL MONITORING PROGRAM

ATMOSPHERIC CONSTITUENTS		RELATED MEASUREMENTS
PARTICULATES	GASES	
RELATED PRIMARILY TO MAN MADE POLLUTION		
CARBON SULFATES NITRATES <u>PROPERTIES OF INTEREST</u> NUMBER DENSITY SIZE DISTRIBUTION MASS CONCENTRATION CHEMICAL COMPOSITION OPTICAL PROPERTIES	CARBON MONOXIDE HYDROCARBONS OXIDES OF NITROGEN (INCLUDING NITRIC ACID) OXIDES OF SULFUR (INCLUDING SULFURIC ACID) AMMONIA HYDROGEN SULFIDE	TEMPERATURE TURBULENCE PRESENCE OF CLOUDS WIND SPEED WIND DIRECTION TIME AND DATE POSITION ALTITUDE HEADING TRUE AIRSPEED RATE OF CLIMB
OF PRIMARY INTEREST TO METEOROLOGY		
AITKEN NUCLEI FREEZING NUCLEI CONDENSATION NUCLEI	OZONE WATER VAPOR CARBON DIOXIDE	

TABLE II. - ATMOSPHERIC CONSTITUENTS SELECTED FOR MEASUREMENT IN INITIAL AIRLINE  
INSTALLATIONS FOR GLOBAL MONITORING PROGRAM

ATMOSPHERIC CONSTITUENT	EXPECTED RANGE	MEASUREMENT PRINCIPLE
PARTICULATE PROPERTIES • NUMBER DENSITY • SIZE DISTRIBUTION CHEMICAL COMPOSITION MASS CONCENTRATION	$10^{-2}$ - $10^3$ /CC 0.5 - 10 MICRONS	{ LIGHT SCATTERING { FILTER/LAB ANALYSES
AITKEN NUCLEI • OZONE • WATER VAPOR • CARBON MONOXIDE OXIDES OF NITROGEN SULFUR DIOXIDE CARBON DIOXIDE	$10 - 10^3$ /CC 0.01 - 2.0 PPM $3 - 10^3$ PPM 0.05 - 0.2 PPM 0.1 - 10 PPB 0.1 - 2 PPB $320 \pm 5$ PPM	CONDENSATION NUCLEI COUNTER (CNC) UV ABSORPTION AL OXIDE HYGROMETER FLUORESCENT NDIR CHEMILUMINESCENT $H_2SO_4$ GENERATOR AND CNC NDIR (NEG. FILTERING)

• NOTE: MEASUREMENTS ON FIRST TWO INSTALLATIONS - OTHERS TO FOLLOW

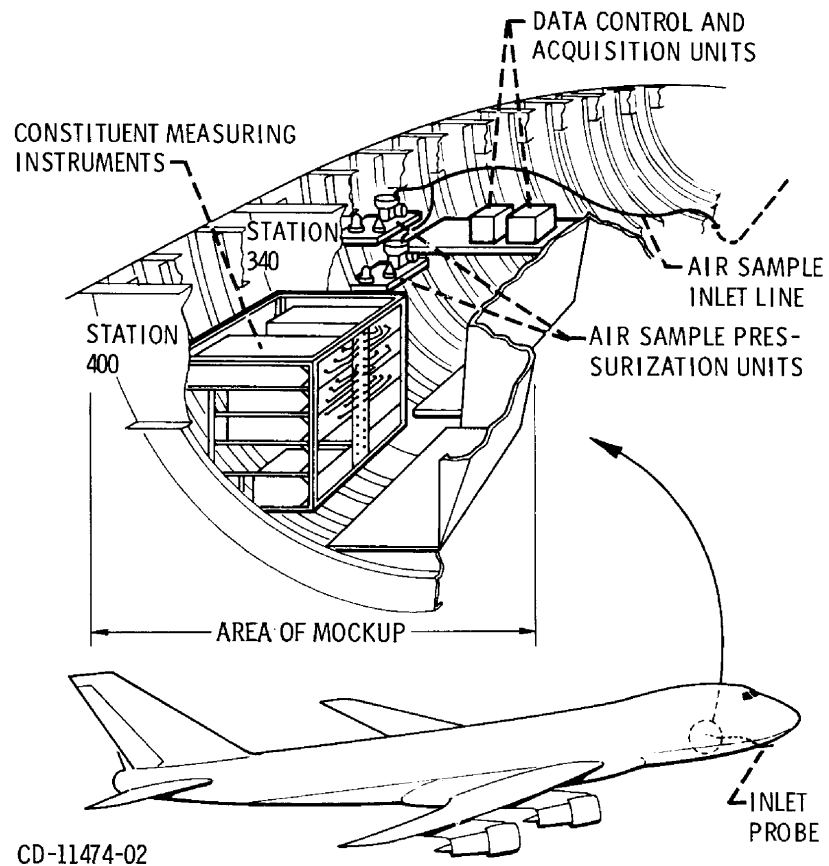

Figure 1. - Air inlet probe and equipment location on Airline 747 airplane.



C-73-3496

Figure 2. - Full scale mockup of area selected in 747 for GASP measuring equipment.

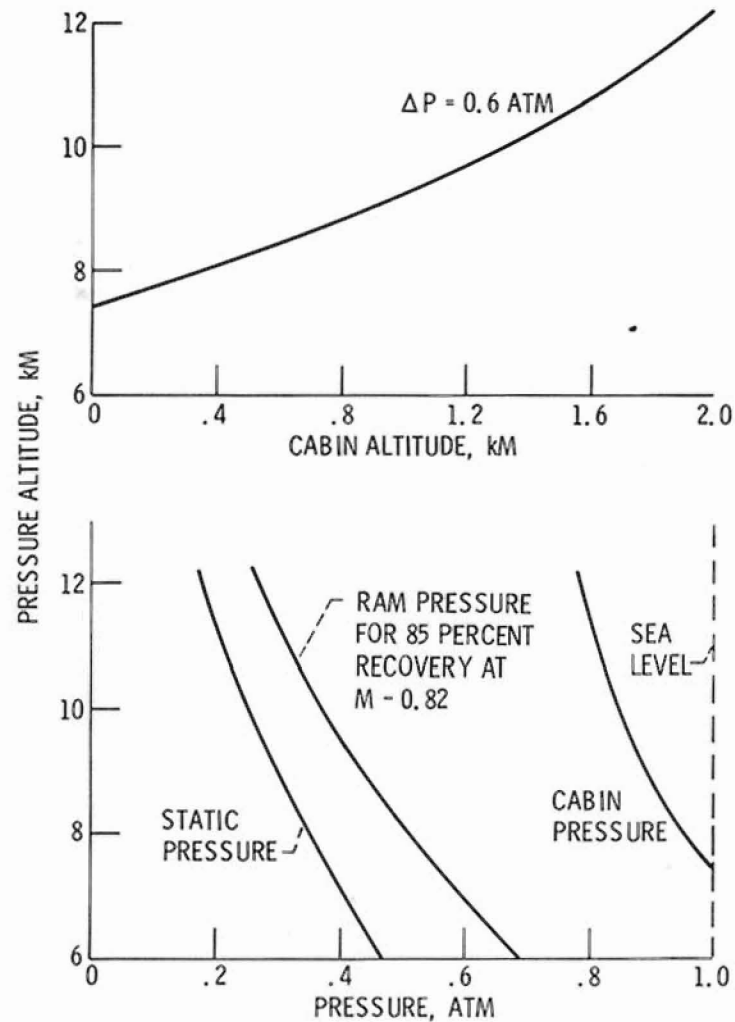

Figure 3. - Pressure environment for air sampling system installed in 747 aircraft.

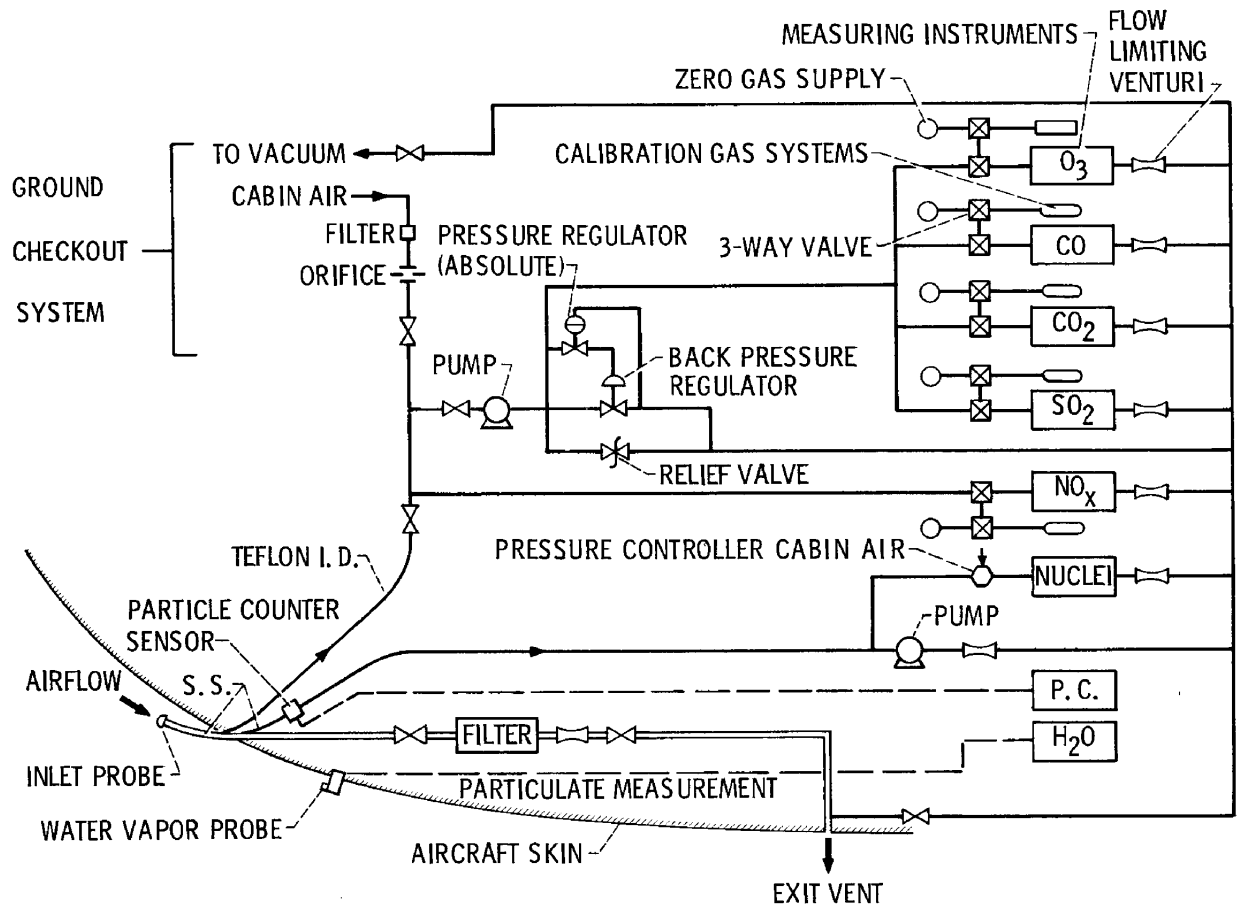

Figure 4. - Basic 747 air sample flow system for GASP

E-7770

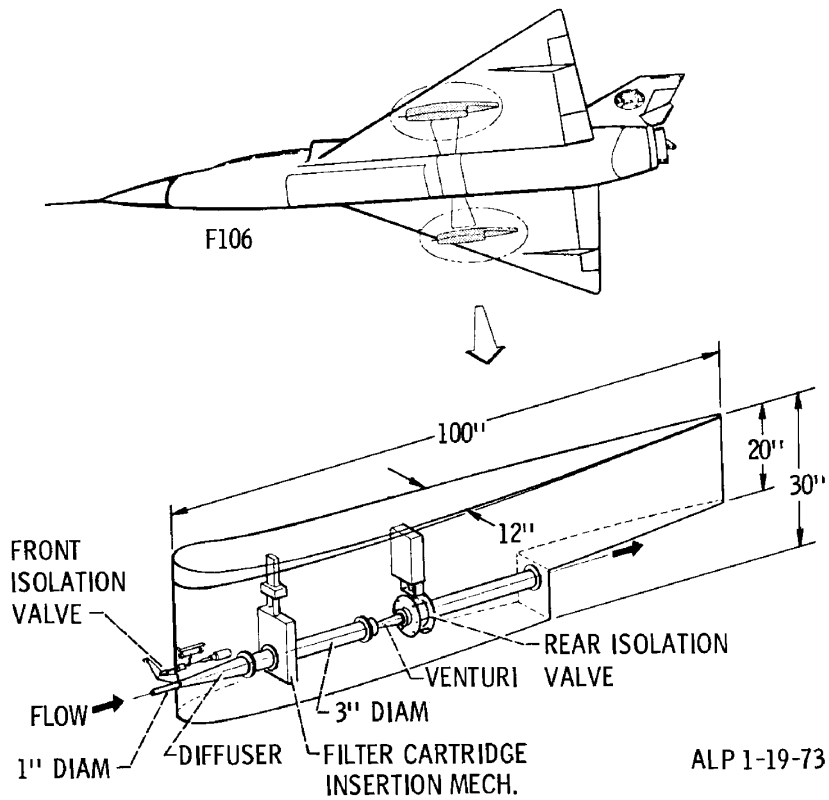

Figure 5. - Filter-type particulate sampling system being developed for airliner operation shown installed in wing pod of F106 aircraft.

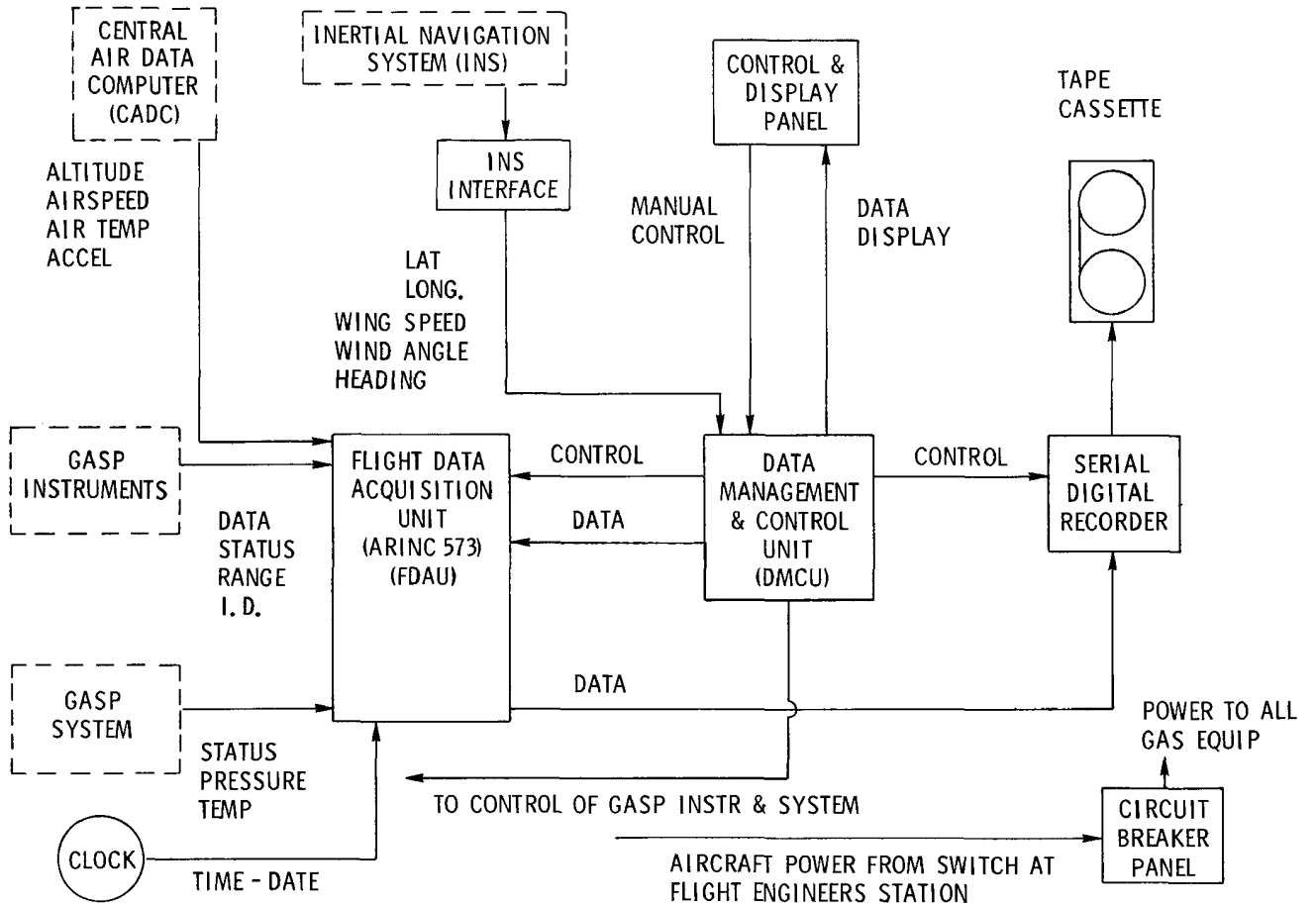
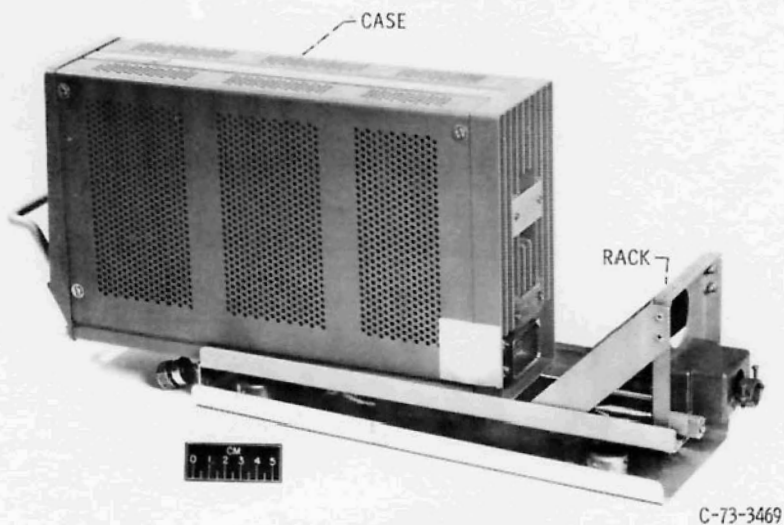
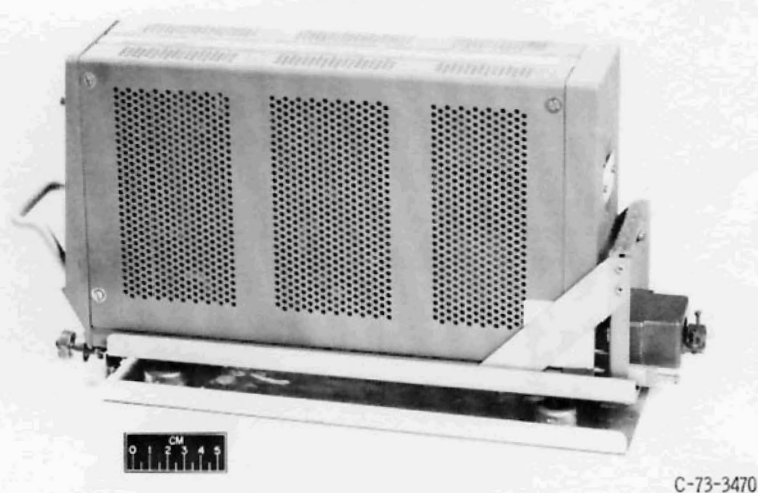

Figure 6. - Basic 747 air sample data acquisition, management, and control systems for GASP.



(a) CASE PARTIALLY INSERTED IN RACK.



(b) CASE SECURED IN RACK.

Figure 7. - Typical airline instrument case and hold-down rack used in repackaging atmospheric constituent monitoring instruments.