

N74-10734

**NASA TECHNICAL
MEMORANDUM**

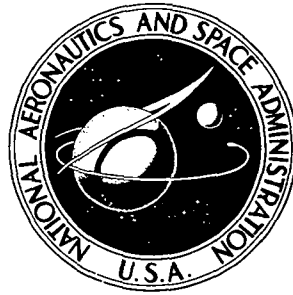

NASA TM X-2926

NASA TM X-2926

**CASE FILE
COPY**

**PERFORMANCE OF A SINGLE-STAGE
TRANSONIC COMPRESSOR WITH A BLADE-TIP
SOLIDITY OF 1.5 AND COMPARISON WITH
1.3- AND 1.7-SOLIDITY STAGES**

*by Walter M. Osborn, Donald C. Urasek,
and Royce D. Moore*

*Lewis Research Center
Cleveland, Ohio 44135*

1. Report No. NASA TN X-2926	2. Government Accession No.	3. Recipient's Catalog No.	
4. Title and Subtitle PERFORMANCE OF A SINGLE-STAGE TRANSONIC COMPRESSOR WITH A BLADE-TIP SOLIDITY OF 1.5 AND COMPARISON WITH 1.3- AND 1.7-SOLIDITY STAGES		5. Report Date November 1973	6. Performing Organization Code
		8. Performing Organization Report No. E-7255	
7. Author(s) Walter M. Osborn, Donald C. Urasek, and Royce D. Moore		10. Work Unit No. 501-24	11. Contract or Grant No.
9. Performing Organization Name and Address Lewis Research Center National Aeronautics and Space Administration Cleveland, Ohio 44135		13. Type of Report and Period Covered Technical Memorandum	
		14. Sponsoring Agency Code	
12. Sponsoring Agency Name and Address National Aeronautics and Space Administration Washington, D.C. 20546		15. Supplementary Notes	
16. Abstract The overall and blade-element performance of a transonic compressor stage with a tip solidity of 1.5 is presented over the stable operating range at rotative speeds from 50 to 100 percent of design speed. Stage peak efficiency of 0.82 was obtained at a weight flow of 29.4 kg/sec (200.4 (kg/sec)/m ² of annulus area) and a pressure ratio of 1.71. Stall margin at design speed was 14 percent. A comparison of three stages in a solidity study showed that the performance of the 1.5 solidity stage and the 1.3 solidity stage were nearly identical but that the performance of the 1.7 solidity stage was significantly lower.			
17. Key Words (Suggested by Author(s)) Turbomachinery; Compressors; Transonic compressors; Axial flow compressors; Turbofans		18. Distribution Statement Unclassified - unlimited	
19. Security Classif. (of this report) Unclassified	20. Security Classif. (of this page) Unclassified	21. No. of Pages 98	22. Price* Domestic, \$3.75 Foreign, \$6.25

PERFORMANCE OF A SINGLE-STAGE TRANSONIC COMPRESSOR WITH A BLADE-TIP SOLIDITY OF 1.5 AND COMPARISON WITH 1.3- AND 1.7-SOLIDITY STAGES

by Walter M. Osborn, Donald C. Urasek, and Royce D. Moore

Lewis Research Center

SUMMARY

The overall and blade-element performance of a transonic compressor stage is presented. The stage has a blade tip solidity of 1.5 for both rotor and stator. Detailed radial and circumferential (behind stators) surveys of the flow conditions were made over the stable operating range at rotative speeds from 50 to 100 percent of design speed. The flow and performance parameters are compared with those of two previously tested compressors, similar in design but with blade-tip solidities of 1.3 and 1.7.

Peak efficiency values for the rotor and stage were 0.87 and 0.82, respectively, and occurred near design weight flow. The corresponding total pressure ratios were 1.77 and 1.71. The experimental values agree closely with the design values. Stall margin for the stage was 14 percent based on weight flow and total pressure ratio at peak efficiency and stall. The experimental rotor losses agree well with the design losses except in the mid-blade span where the blade dampers are located. The stator losses also agree well with design losses except near the end walls.

Comparison of the three stages in the solidity series showed that the performance of the 1.3 and 1.5 solidity stages were nearly identical, with a peak efficiency of approximately 82 percent. The performance of the 1.7 solidity stage was significantly lower, with a peak efficiency of 78.4 percent. Stall margin was highest for the 1.3 solidity stage (17 percent) and lowest for the 1.7 solidity stage (11.4 percent).

INTRODUCTION

A research program on axial-flow fans and compressors for advanced airbreathing engines is currently being conducted at the NASA Lewis Research Center. This program

is primarily directed towards providing technology to permit reducing the size and weight of fans and compressors while maintaining high levels of performance.

As a part of this program, a series of three transonic compressor stages was designed and tested to evaluate the effect of blade row solidity on efficiency and stall margin. The blade tip solidities for the three stages were 1.3, 1.5, and 1.7. The solidity was changed by varying the number of blades while maintaining the same velocity diagrams and flow path. The stages were designed such that the tip solidity of both the rotor and stator blades were the same. The performance for the 1.3 and 1.7 solidity stages are presented in references 1 and 2, respectively.

This report presents the design, overall, and blade-element performances for both the rotor and stator of the 1.5 solidity stage. The stage is designated stage 8-8 (rotor 8, stator 8). The blade-element survey data were obtained at 11 radial positions. The data were obtained over the stable operating range of the stage for six rotative speeds from 50 to 100 percent of design speed. The data presented in this report are in tabular as well as in plotted form. The symbols are defined and the equations are given in appendixes A and B. The definitions and units used for the tabular data are presented in appendix C. In addition, a limited number of performance parameters are compared for the three stages in this stage solidity series.

AERODYNAMIC DESIGN

Three computer programs were used in the design of this compressor stage: the streamline analysis program, the blade geometry program, and the blade coordinate program. These three computer programs are presented in references 3 and 4; only a brief description of each is presented in this report.

The streamline analysis program was used to calculate the flow field parameters at several axial locations including planes approximating the blade leading and trailing edges for both the rotor and stator. The weight flow, rotative speed, flow path geometry, and radial distributions of total pressure and temperature are inputs in this program. The program accounts for both streamline curvature and entropy gradients; boundary-layer blockage factors are also included.

The distributions of velocity vector, total pressure, and total temperature calculated in the streamline analysis program are used in the blade geometry program to compute blade geometry parameters. Total loss computed within the program includes a calculated shock loss (as related to the selected blade shape) and a profile loss. The profile losses used for this stage are based on loss - diffusion-factor correlations that include the data presented in reference 3 for the rotor and in reference 5 for the stator.

The blade geometry parameters are used in the blade coordinate program to compute blade elements on conical surfaces approximating the stream surfaces passing through

the blade. The blade elements are then stacked on a line passing through their centers of gravity, and Cartesian blade coordinates, which are used directly in fabrication, are computed.

The overall design parameters for stage 8-8 are listed in table I, and the flow path geometry is shown in figure 1. This stage was designed for an overall pressure ratio of 1.750 at a weight flow of 29.5 kilograms per second ($200.6 \text{ (kg/sec)/m}^2$ of annulus area). The design tip speed was 423 meters per second. The stage was designed for a tip solidity of 1.5 for the rotor and 1.5 for the stator. This resulted in 49 rotor blades with an aspect ratio of 2.4 and 54 stator blades with an aspect ratio of 2.0.

The blade-element design parameters for rotor 8 are presented in table II. This rotor was designed for a radially constant total pressure ratio of 1.80. The stator blade-element design parameters are given in table III. The blade geometry is presented in table IV for rotor 8 and in table V for stator 8. Both the rotor and stator have multiple-circular-arc blade shapes.

The equations used for calculating overall blade-element performance parameters are presented in appendix B. All definitions and units presented in the tables are given in appendix C.

APPARATUS AND PROCEDURE

Compressor Test Facility

The compressor stage was tested in the Lewis single-stage compressor facility which is described in detail in reference 4. A schematic diagram of the facility is shown in figure 2. Atmospheric air enters the test facility at an inlet located on the roof of the building and flows through the flow measuring orifice and into the plenum chamber upstream of the test stage. The air then passes through the experimental compressor stage, into the collector, and is exhausted to the atmosphere.

Test Stage

Photographs of the rotor and stator are shown in figures 3 and 4, respectively. Each rotor blade has a vibration damper located at about 48 percent span from the outlet rotor tip. The maximum thickness of the damper was 0.214 centimeter. The nonrotating radial tip clearance of the rotor was a nominal 0.050 centimeter at ambient conditions. The axial spacing between the rotor hub trailing edge and the stator hub leading edge was 3.33 centimeters.

Instrumentation

The compressor weight flow was determined from measurements on a calibrated thin-plate orifice that was 38.9 centimeters in diameter. The temperature at the orifice was measured with two Chromel/Alumel thermocouples. Pressures at the orifice were measured by calibrated transducers.

Radial surveys of the flow were made upstream of the rotor, between the rotor and stator, and downstream of the stator (fig. 1). Photographs of the survey probes appear in figure 5. Total pressure, total temperature, and flow angle were measured with the combination probe (fig. 5(a)), and the static pressure was measured with an 8° C-shaped wedge probe (fig. 5(b)). Each probe was positioned with a null-balancing, stream-direction-sensitive control system that automatically alined the probe to the direction of flow. The probes were angularly alined in an air tunnel. Two combination probes and two wedge static probes were used at each of the three measuring stations. The thermocouple material was iron constantan.

Inner- and outer-wall static pressure taps were located at the same axial stations as the survey probes. The circumferential locations of both types of survey probes along with inner and outer wall static pressure taps are given in figure 6. The combination probe downstream of the stator (station 3) was circumferentially traversed one stator blade passage (6.7°) counterclockwise from the nominal value shown.

An electronic speed counter, in conjunction with a magnetic pickup, was used to measure rotative speed (rpm).

The estimated errors of the data based on inherent accuracies of the instrumentation and recording system are as follows:

Weight flow, kg/sec	±0.3
Rotative speed, rpm	±30
Flow angle, deg.	±1
Temperature, K	±0.6
Rotor inlet total pressure, N/cm ²	±0.01
Rotor outlet total pressure, N/cm ²	±0.10
Stator outlet total pressure, N/cm ²	±0.10
Rotor inlet static pressure, N/cm ²	±0.04
Rotor outlet static pressure, N/cm ²	±0.07
Stator outlet static pressure, N/cm ²	±0.07

At each measuring station the integrated weight flow is computed based on the radial survey data. An indication of the consistency of the data can be observed by comparing integrated weight flows at each of the measuring stations to the orifice weight flow.

Test Procedure

The stage survey data were taken over a range of weight flows from maximum flow to the near-stall conditions. At 70, 90, and 100 percent of design speed, radial surveys were taken at five weight flows. At 50, 60, and 80 percent of design speed, radial surveys were taken for the near-stall weight flow only. Data were recorded at 11 radial positions for each speed and weight flow.

At each radial position the combination probe behind the stator was circumferentially traversed to nine different locations across the outlet of the stator passage. The wedge probe was set at midgap because previous studies showed that the static pressure across the stator gap was nearly constant. Values of pressure, temperature, and flow angle were recorded at each circumferential position. At the last circumferential position values of pressure, temperature, and flow angle were also recorded at stations 1 and 2. All probes were then traversed to the next radial position and the circumferential traverse procedure repeated.

At each of the six rotative speeds the back pressure on the stage was increased by closing the sleeve valve in the collector until a stalled condition was detected by a sudden drop in stage outlet total pressure. This pressure was measured by a probe located at midpassage and was recorded on an X-Y plotter. Stall was corroborated by large increases in the measured blade stresses on both rotor and stator along with a sudden change in noise level.

Calculation Procedure

Measured total temperatures and total pressures were corrected for Mach number and streamline slope. These corrections were based on instrument probe calibrations given in reference 6. The stream static pressure was corrected for Mach number and streamline slope based on an average calibration for the type of probe used.

Because of the physical size of the C-shaped static-pressure wedges, it was impractical to obtain static-pressure measurements at the 5, 10, and 95 percent of span locations. The static pressure at 95 percent span was obtained by assuming a linear variation in static pressure between the values at the inner wall and at 90 percent span. A similar variation was assumed between the static pressure measurements at the outer wall and the 30 percent span to obtain the static pressures at the 5 and 10 percent span locations.

At each radial position, averaged values of the nine circumferential measurements of pressure, temperature, and flow angle downstream of the stator (station 3) were calculated. The nine values of total temperature were mass averaged to obtain the stator-outlet total temperature. The nine values of total pressure were energy averaged. The

measured values of pressure, temperature, and flow angle were used to calculate axial and tangential velocities at each circumferential position. The flow angle presented for each radial position is calculated based on these mass-averaged axial and tangential velocities. To obtain the overall performance, the radial values of total temperature were mass averaged, and the values of total pressure were energy averaged. At each measuring station, the integrated weight flow was computed based on the radial survey data.

The data, measured at the three measuring stations, were translated to the rotor and stator blade leading and trailing edges by the method presented in reference 4.

The weight flow at stall was obtained in the following manner: from a condition near stall, the collector valve was slowly closed in small increments. At each increment the weight flow was obtained. The weight flow obtained just before stall occurred is called the stall weight flow. The pressure ratio at stall was obtained by extrapolating the total pressure obtained from the survey data to the stall weight flow.

Orifice weight flow, total pressures, static pressures, and temperatures were all corrected to sea-level conditions based on the rotor inlet conditions.

RESULTS

The results from this investigation will be presented in four main sections: The overall performance for the rotor and stage, the radial distributions of several performance parameters, for the rotor and stator, and, finally, the blade-element data for both the rotor and stator. The data presented are computer plotted. Data points are omitted if they fall outside the range of the parameters shown in the figures.

All machine plotted data and some additional performance parameters are presented in tabular form. The overall performance data are presented in table VI. The blade-element data are presented first for the rotor and then for the stator in tables VII and VIII. The abbreviations and units used for the tabular data are defined in appendix C.

Overall Performance

The overall performance for rotor 8 and for stage 8-8 are presented in figures 7 and 8. For both of these computer plotted figures, data are presented for speeds from 50 to 100 percent of design speed. For 70, 90, and 100 percent of design speed, data are presented at several weight flows from choke to the near-stall conditions. For 50, 60, and 80 percent of design speed, the overall performance is presented for the near-stall condition only. Design point values are shown as solid symbols in both figures. The stall

line (dashed line) shown in figure 8 was determined using the method discussed in the Test Procedure Section.

At design speed peak efficiency for both rotor and stage occurred at a measured equivalent weight flow of 29.4 kilograms per second ($200.4 \text{ (kg/sec)/m}^2$ of annulus area). This is essentially design weight flow. At this point the experimental values of total pressure ratio, total temperature ratio, and temperature rise efficiency for the rotor (fig. 7) were 1.77, 1.20, and 0.87, respectively. For the stage (fig. 8) the experimental values were 1.71, 1.20, and 0.82. The measured temperature ratio is the same as the design value and indicates that the design energy input was achieved. The slightly lower than design pressure ratio of the rotor results in a rotor efficiency that is approximately 2 percentage points lower than design efficiency. As the measured and design loss in efficiency across the stator blade row are the same, the slightly lower than design stage efficiency (approximately 2 percentage points) probably results from the lower than design rotor efficiency.

At design speed the stall margin for the stage was 14 percent. The stall margin (defined in appendix B) is based on the equivalent weight flow and pressure ratio at the peak efficiency point and similar values for a point at stall (stall line values, fig. 8).

Radial Distributions

The radial distributions of selected flow and performance parameters for the rotor and the stator are shown in figures 9 and 10, respectively. The radial distributions are presented for design speed at flow conditions of near stall, peak efficiency, and near choke. Curves are fitted to the peak efficiency data in order to compare these data with the design values at a weight flow of 29.5 kilograms per second. Design values are shown by solid symbols.

Rotor. - The total-temperature-ratio distribution agrees well with design over the entire blade span. The total-pressure ratio is higher than design from the blade tip to 30 percent blade span and near the hub but is lower than design over the remainder of the blade. The radial distribution of total-temperature ratio and total-pressure ratio results in an efficiency distribution that agrees well with design values except in the damper region. The deviation angles were lower than design from the blade tip to midspan and near the hub but were higher than design over the remainder of the blade. Blade loading (diffusion factor) agrees well with design across the entire blade passage. The losses agree well with design between the blade tip and 30 percent span. Losses are greater than design from 30 to 80 percent span, particularly in the damper region (48 percent span). The high damper losses contributed to the rotor experimental peak efficiency being 2 percentage points lower than the design efficiency. The effect of the damper on the loss distribution was unaccounted for in the aerodynamic design of the rotor blades.

Stator. - The deviation angle (fig. 10) was higher than design over the entire blade span except at the 70 percent station. Blade loading (diffusion factor) approximated the design, with exceptions at 10 and 90 percent blade span. The total loss distribution agrees reasonably well with design except at 5 and 95 percent blade span.

Variation of Blade-Element Performance With Incidence Angle

The variations of selected rotor and stator blade-element performance parameters with incidence angle are presented in figures 11 and 12, respectively. The data are presented for 70, 90, 100 percent of rotor design speed at blade elements located at 5, 10, 30, 52.5, 70, 90, and 95 percent of blade span as measured from the rotor outlet blade tip. Design values are shown by solid symbols. The various curves as a function of incidence angle are presented primarily for future correlations in comparing the performance of these blades with other blade designs. Only a few brief observations will be made herein.

Rotor. - The rotor blades were designed for minimum loss to occur at zero incidence angle. Except at the 5-percent-span location, the minimum loss was obtained within 1.5° of zero incidence angle. At the 5-percent-span location the losses continued to decrease as the flow was increased (decreasing incidence angle) to the maximum flow condition. The measured minimum loss values agreed closely with design values over the blade span except near the blade hub (95.0-percent span) and at the 52.5-percent span where the effect of the damper is evident. The deviation angles were less than design at all spans except 70- and 90-percent spans.

Stator. - The suction-surface incidence angle corresponding to minimum loss was within 3° of the design incidence angle except in the blade tip regions. At the 5-, 10-, and 95-percent span locations, the minimum loss was greater than design but at all other spans the minimum loss was equal to or less than design. The deviation angles were generally greater than design, particularly near the tip and near the hub.

COMPARISON OF PERFORMANCE WITH OTHER STAGES IN THIS SERIES

Overall Performance

The overall performance for the three stages in the solidity series are compared in figure 13. The stages had tip solidities (for both the rotor and stator) of 1.3 (ref. 1), 1.5 (this report), and 1.7 (ref. 2). The overall performance is compared at 70, 90, and 100 percent of design speed.

The total pressure ratio performance curves for the 1.3 and 1.5 solidity stages are approximately the same for all three speeds. The total pressure ratio has significantly dropped off for the 1.7 solidity stage. At design speed, peak efficiency is approximately 0.820 for the 1.3 and 1.5 solidity stages but is 0.784 for the 1.7 solidity stage. Peak efficiency for the 1.3 and 1.5 solidity stages occurred at essentially design weight flow (29.5 kg/sec). However, the peak efficiency for the 1.7 solidity stage occurred at a lower weight flow (28.6 kg/sec). Stall margin was best for the 1.3 solidity stage (17 percent) followed by the 1.5 (14 percent) and 1.7 (11.4 percent) solidity stages. All three stages stalled as the rotor tip D-factor increased to about 0.6.

Radial Distributions

Comparisons of selected radial distributions of performance at design speed for the three blade-tip solidities of 1.3, 1.5, and 1.7 are presented for the rotors and stators in figures 14 and 15, respectively. All results are shown at near design weight flow. For the data presented the 1.3 and 1.5 solidity blades were operating at peak efficiency. However, the 1.7 solidity blade was at a choked condition at near design weight flow and operating at a low efficiency and low pressure ratio.

Rotor. - The spanwise distribution of efficiency and pressure ratio (fig. 14) are nearly the same for the 1.3 and 1.5 solidity rotors. The level of these distributions for the 1.7 rotor is considerably less than those for the other two rotors. The blade loading (diffusion factor) for the 1.7 solidity rotor is also lower than those for the other two rotors, but the losses are the highest. If the maximum efficiency point of the 1.7 solidity rotor (table VII(c), ref. 2) is used for comparison (lower than design weight flow), the losses are still highest for the 1.7 solidity rotor and the efficiency is lowest.

Stator. - The spanwise distribution of diffusion factor (blade loading) is nearly the same for the 1.3 and 1.5 solidity stators. The 1.7 solidity stator has a much lower level of blade loading than the other two stators, but it has the highest losses of all three stators. If the maximum efficiency point of the 1.7 solidity stator (table XIII(c), ref. 2) is used for comparison (lower than design weight flow), the 1.7 solidity stator still has slightly higher losses than the other two stators in the middle portions of the blade span. The abrupt increase in blade loading and losses in the hub and tip regions for all three stators indicates that flow separation may be occurring in these regions. The deviation angle trends are the same for all three stators.

Discussion of Solidity Effects

A previous study of rotors only at lower blade loading levels than those used in the present investigation indicated an increase in performance as the blade solidity was increased from 1.1 to 1.5 (ref. 7). Because of that study, it was expected that, at the higher loading level of the present stage, the higher solidities would provide improved performance. However, the three transonic stages compared in this report indicated that the best performance was obtained with the 1.3 and 1.5 blade tip solidities. The 1.7 solidity resulted in lower performance primarily because of higher losses. The highest solidity stage also operated at a lower maximum flow rate and achieved its best performance (but still lower than the other two stages) at lower than the design flow rate. Because of the higher number of blades, the design blade loading (D-factor) of the higher solidity rotor is lower than that of the other rotors, and the rotor losses might be expected to be lower. Rotor tip design D-factors are 0.503, 0.519, and 0.537 for the 1.7, 1.5, and 1.3 solidity rotors, respectively.

The stage peak efficiencies are about 5 percentage points lower than the rotor peak efficiencies for each of the three stages. The stators do not appear to limit stage performance. Thus, the lower performance of the highest solidity stage may result from the design approach used for the three rotors. The minimum flow area over that ideally required, considering the flow losses ahead of the minimum area, was designed to be about the same for each of the rotors. This was accomplished by controlling the suction-surface turning in the forward portion of the blade passage (X-factor). Because of the increased blade blockage in the higher solidity rotor (greater number of blades) more forward turning was required. This probably resulted in higher calculated suction-surface Mach numbers and higher shock losses than were accounted for in the design. Since the shock loss occurs ahead of the minimum area, this would reduce the area margin and could have resulted in local internal restriction of the flow. This probably accounts for the higher than design losses and lower than design flow rates indicated for the higher solidity stage. Thus, the design approach of using greater turning in the forward portion of the blading to achieve the desired flow area may have resulted in the performance deficiency for the higher solidity rotor.

The criteria used in this solidity study, wherein the rotor aerodynamic blade chord was held constant and the solidity was varied by changing the number of blades, may have imposed a restriction on the high solidity stage. If longer blade chords were used, the flow path geometry could be modified for a high solidity design to achieve the desired flow margin without the high calculated blade surface Mach numbers. Further analyses of the blade-element data may indicate other design approaches that could improve the performance of the high solidity stage.

SUMMARY OF RESULTS

This report presents both the aerodynamic design parameters and the overall and blade-element performance of a transonic compressor stage having tip solidities of 1.5 for both rotor and stator. Detailed radial surveys of the flow conditions in front of the rotor, between the rotor and stator, and behind the stator were made over the stage stable operating flow range at rotative speeds from 50 to 100 percent of design speed. Comparisons of the performance of three stages with tip solidities of 1.3, 1.5, and 1.7 are also made. This investigation yielded the following results:

1. At design speed, the 1.5 solidity stage peak efficiency of 0.82 occurred at a pressure ratio of 1.71 and a near-design weight flow of 29.4 kilograms per second. Stage stall margin was 14 percent, based on pressure ratio and weight flow at peak efficiency and stall.

2. The 1.5 solidity rotor peak efficiency of 0.87 occurred at a pressure ratio of 1.77 and a near design weight flow of 29.4 kilograms per second. The two point difference between the design and measured value of efficiency was attributed to high losses in the blade damper region that were not accounted for in the theoretical rotor design.

3. Except in the blade tip regions, the suction-surface incidence angles corresponding to minimum losses at design speed were within 1.5° of the design value for the rotor and 3° for the stator. Generally, the minimum loss values for both rotor and stator were equal to or slightly higher than design values.

4. Comparison of three stages used to evaluate the effect of solidity showed that the overall performance results of the 1.3 and 1.5 solidity stages were nearly identical. The performance of the 1.7 solidity stage was significantly lower. At design speed peak efficiency was approximately 0.820 for the 1.3 and 1.5 solidity stages and 0.784 for the 1.7 solidity stage.

5. Stall margin was highest for the 1.3 solidity stage (17 percent) and lowest for the 1.7 solidity stage (11.4 percent).

6. At near design weight flow, the radial distribution of total losses for both rotor and stator of the 1.7 solidity stage were greater over the entire blade span than for the lower solidity stages.

Lewis Research Center,
National Aeronautics and Space Administration,
Cleveland, Ohio, July 23, 1973,
501-24.

APPENDIX A

SYMBOLS

A_{an}	annulus area at rotor leading edge, 0.147 m^2
A_f	frontal area at rotor leading edge, 0.198 m^2
C_p	specific heat at constant pressure, 1004 J/kg-K
c	aerodynamic chord, cm
D	diffusion factor
g	acceleration of gravity, 9.81 m/sec^2
i_{mc}	mean incidence angle, angle between inlet air direction and line tangent to blade mean camber line at leading edge, deg
i_{ss}	suction-surface incidence angle, angle between inlet air direction and line tangent to blade suction surface at leading edge, deg
J	mechanical equivalent of heat
N	rotative speed, rpm
P	total pressure, N/cm^2
p	static pressure, N/cm^2
r	radius, cm
SM	stall margin
T	total temperature, K
U	wheel speed, m/sec
V	air velocity, m/sec
W	weight flow, kg/sec
Z	axial distance referenced from rotor blade hub leading edge, cm
α_c	cone angle, deg
α_s	slope of streamline, deg
β	air angle, angle between air velocity and axial direction, deg
β'_c	relative meridional air angle based on cone angle, $\arctan(\tan \beta'_m \cos \alpha_c / \cos \alpha_s)$, deg
γ	ratio of specific heats (1.40)

δ	ratio of rotor inlet total pressure to standard pressure of 10.13 N/cm ²
δ°	deviation angle, angle between exit air direction and tangent to blade mean camber line at trailing edge, deg
η	efficiency
θ	ratio of rotor inlet total temperature to standard temperature of 288.2 K
κ_{mc}	angle between the blade mean camber line and the meridional plane, deg
κ_{SS}	angle between the blade suction surface camber line at the leading edge and the meridional plane, deg
σ	solidity, ratio of chord to spacing
$\bar{\omega}$	total loss coefficient
$\bar{\omega}_p$	profile loss coefficient
$\bar{\omega}_s$	shock loss coefficient

Subscripts:

ad	adiabatic (temperature rise)
LE	blade leading edge
id	ideal
m	meridional direction
mom	momentum-rise
p	polytropic
r	radial direction
ref	reference
TE	blade trailing edge
z	axial direction
θ	tangential direction
1	instrumentation plane upstream of rotor
2	instrumentation plane between rotor and stator
3	instrumentation plane downstream of stator

Superscript:

'	relative to blade
---	-------------------

APPENDIX B

EQUATIONS

Suction-surface incidence angle -

$$i_{ss} = (\beta'_c)_{LE} - \kappa_{ss} \quad (B1)$$

Mean incidence angle -

$$i_{mc} = (\beta'_c)_{LE} - (\kappa_{mc})_{LE} \quad (B2)$$

Deviation angle -

$$\delta^o = (\beta'_c)_{TE} - (\kappa_{mc})_{TE} \quad (B3)$$

Diffusion factor -

$$D = 1 - \frac{V'_{TE}}{V'_{LE}} + \left| \frac{(rV_\theta)_{TE} - (rV_\theta)_{LE}}{(r_{TE} + r_{LE})^\sigma (V'_{LE})'} \right| \quad (B4)$$

Total loss coefficient -

$$\bar{\omega} = \frac{(P'_{id})_{TE} - P'_{TE}}{P'_{LE} - p_{LE}} \quad (B5)$$

Profile loss coefficient -

$$\bar{\omega}_p = \bar{\omega} - \bar{\omega}_s \quad (B6)$$

Total loss parameter -

$$\frac{\bar{\omega} \cos(\beta'_m)_{TE}}{2\sigma} \quad (B7)$$

Profile loss parameter -

$$\frac{\bar{\omega}_p \cos(\beta'_m)_{TE}}{2\sigma} \quad (B8)$$

Adiabatic (temperature rise) efficiency -

$$\eta_{ad} = \frac{\left(\frac{P_{TE}}{P_{LE}}\right)^{(\gamma-1)/\gamma} - 1}{\frac{T_{TE}}{T_{LE}} - 1} \quad (B9)$$

Momentum-rise efficiency -

$$\eta_{mom} = \frac{\left(\frac{P_{TE}}{P_{LE}}\right)^{(\gamma-1)/\gamma} - 1}{\frac{(UV_\theta)_{TE} - (UV_\theta)_{LE}}{T_{LE} g J C_p}} \quad (B10)$$

Equivalent weight flow -

$$\frac{W\sqrt{\theta}}{\delta} \quad (B11)$$

Equivalent rotative speed -

$$\frac{N}{\sqrt{\theta}} \quad (B12)$$

Weight flow per unit annulus area -

$$\frac{\frac{W\sqrt{\theta}}{\delta}}{A_{an}} \quad (B13)$$

Weight flow per unit frontal area -

$$\frac{\frac{W\sqrt{\theta}}{\delta}}{A_f} \quad (B14)$$

Head-rise coefficient -

$$\frac{gJ C_p T_{LE}}{U_{tip}^2} \left[\left(\frac{P_{TE}}{P_{LE}} \right)^{(\gamma-1)/\gamma} - 1 \right] \quad (B15)$$

Flow coefficient -

$$\left(\frac{V_z}{U_{tip}} \right)_{LE} \quad (B16)$$

Stall margin -

$$SM = \left[\frac{\left(\frac{P_{TE}}{P_{LE}} \right)_{stall} \times \left(\frac{W\sqrt{\theta}}{\delta} \right)_{ref}}{\left(\frac{P_{TE}}{P_{LE}} \right)_{ref} \times \left(\frac{W\sqrt{\theta}}{\delta} \right)_{stall}} - 1 \right] \times 100 \quad (B17)$$

Polytropic efficiency -

$$\eta_p = \exp \left[\frac{\left(\frac{P_{TE}}{P_{LE}} \right)^{(\gamma-1)/\gamma}}{\frac{T_{TE}}{T_{LE}}} \right] \quad (B18)$$

APPENDIX C

DEFINITIONS AND UNITS USED IN TABLES

ABS	absolute
AERO CHORD	aerodynamic chord, cm
AREA RATIO	ratio of actual flow area to critical area (where local Mach number is one)
BETAM	meridional air angle, deg
CONE ANGLE	angle between axial direction and conical surface representing blade element, deg
DELTA INC	difference between mean camber blade angle and suction-surface blade angle at leading edge, deg
DEV	deviation angle (defined by eq. (B3)), deg
D-FACT	diffusion factor (defined by eq. (B4))
EFF	adiabatic efficiency (defined by eq. (B9))
IN	inlet (leading edge of blade)
INCIDENCE	incidence angle (suction surface defined by eq. (B1) and mean defined by eq. (B2))
KIC	angle between blade mean camber line at leading edge and meridional plane, deg
KOC	angle between blade mean camber line at leading at trailing edge and meridional plane, deg
KTC	angle between blade mean camber line at transition point and meridional plane, deg
LOSS COEFF	loss coefficient (total defined by eq. (B5) and profile defined by eq. (B6))
LOSS PARAM	loss parameter (total defined by eq. (B7) and profile defined by eq. (B8))
MERID	meridional
MERID VFL R	meridional velocity ratio
OUT	outlet (trailing edge of blade)
PERCENT SPAN	percent of blade span from tip at rotor outlet

PHISS	suction-surface camber ahead of assumed shock location, deg
PRESS	pressure, N/cm^2
PROF	profile
RADII	radius, cm
REL	relative to blade
RI	inlet radius (leading edge of blade), cm
RO	outlet radius (trailing edge of blade), cm
RP	radial position
RPM	equivalent rotative speed, rpm
SETTING ANGLE	angle between aerodynamic chord and meridional plane, deg
SOLIDITY	ratio of aerodynamic chord to blade spacing
SPEED	speed, m/sec
SS	suction surface
STREAMLINE	
SLOPE	slope of streamline, deg
TANG	tangential
TEMP	temperature, K
TI	thickness of blade at leading edge, cm
TM	thickness of blade at maximum thickness, cm
TO	thickness of blade at trailing edge, cm
TOT	total
TOTAL CAMBER	difference between inlet and outlet blade mean camber lines, deg
VEL	velocity, m/sec
WT FLOW	equivalent weight flow, kg/sec
X FACTOR	ratio of suction-surface camber ahead of assumed shock location of multiple-circular-arc blade section to that of double circular- arc blade section
ZIC	axial distance to blade leading edge from inlet, cm
ZMC	axial distance to blade maximum thickness point from inlet, cm
ZOC	axial distance to blade trailing edge from inlet, cm
ZTC	axial distance to transition point from inlet, cm

REFERENCES

1. Urasek, Donald C. ; Moore, Royce D. ; and Osborn, Walter M. : Performance of a Single-Stage Transonic Compressor with a Blade-Tip Solidity of 1.3. NASA TM X-2645, 1972.
2. Moore, Royce D. ; and Reid, Lonnie: Performance of a Single-Stage Axial-Flow Transonic Compressor Stage with a Blade Tip Solidity of 1.7. NASA TM X-2658, 1972.
3. Ball, Calvin L. ; Janetzke, David C. ; and Reid, Lonnie: Performance of 1380-Foot-per-Second-Tip-Speed Axial-Flow Compressor Rotor with Blade Tip Solidity of 1.5. NASA TM X-2379, 1971.
4. Crouse, James E. ; Janetzke, David C. ; and Schwirian, Richard E. : A Computer Program for Composing Compressor Blading from Simulated Circular-Arc Elements on Conical Surfaces. NASA TN D-5437, 1969.
5. Keenan, M. J. ; Harley, K. G. ; and Bogardus, G. A. : Experimental Evaluation of Transonic Stators, Data and Performance Report, Multiple-Circular-Arc Stator A. Rep. PWA-3260, Pratt & Whitney Aircraft (NASA CR-54621), 1968.
6. Glawe, George E. ; Krause, Lloyd N. ; and Dudzinski, Thomas J. : A Small Combination Sensing Probe for Measurement of Temperature, Pressure, and Flow Direction. NASA TN D-4816, 1968.
7. Hartman, Melvin J. ; Benser, William A. ; Hauser, Cavour H. ; and Ruggeri, Robert S. : Fan and Compressor Technology. Aircraft Propulsion. NASA SP-259, 1971, pp. 1-36.

TABLE I. - DESIGN OVERALL PARAMETERS

FOR STAGE 8-8

ROTOR TOTAL PRESSURE RATIO.....	1.800
STAGE TOTAL PRESSURE RATIO	1.750
ROTOR TOTAL TEMPERATURE RATIO.....	1.205
STAGE TOTAL TEMPERATURE RATIO	1.205
ROTOR ADIABATIC EFFICIENCY.....	0.890
STAGE ADIABATIC EFFICIENCY	0.843
ROTOR POLYTROPIC EFFICIENCY.....	0.898
STAGE POLYTROPIC EFFICIENCY	0.855
ROTOR HEAD RISE COEFFICIENT.....	0.296
STAGE HEAD RISE COEFFICIENT	0.281
FLOW COEFFICIENT.....	0.474
WT FLOW PER UNIT FRONTAL AREA	149.172
WT FLOW PER UNIT ANNULUS AREA.....	200.600
WT FLOW	29.484
RPM.....	16100.000
TIP SPEED	422.888

TABLE II. - DESIGN BLADE-ELEMENT PARAMETERS FOR ROTOR 8

RP	RADII		ABS BETAM		REL BETAM		TOTAL TEMP		TOTAL PRESS	
	IN	OUT	IN	OUT	IN	OUT	IN	RATIO	IN	RATIO
TIP	25.082	24.701	0.	50.1	65.6	58.7	288.2	1.252	10.13	1.800
1	24.568	24.193	-0.	47.8	64.5	57.6	288.2	1.237	10.13	1.800
2	24.021	23.685	0.	46.3	63.5	56.5	288.2	1.225	10.13	1.800
3	21.754	21.653	0.	45.1	60.0	51.1	288.2	1.206	10.13	1.800
4	20.287	20.383	0.	45.6	58.2	46.7	288.2	1.200	10.13	1.800
5	19.989	20.129	0.	45.8	57.8	45.7	288.2	1.199	10.13	1.800
6	19.690	19.875	0.	46.0	57.5	44.6	288.2	1.199	10.13	1.800
7	19.388	19.621	0.	46.2	57.2	43.5	288.2	1.198	10.13	1.800
8	19.085	19.367	0.	46.5	56.9	42.4	288.2	1.197	10.13	1.800
9	16.891	17.589	0.	48.4	54.6	32.6	288.2	1.194	10.13	1.800
10	14.175	15.557	0.	52.3	52.2	15.8	288.2	1.195	10.13	1.800
11	13.447	15.049	0.	53.7	51.6	9.9	288.2	1.197	10.13	1.800
HUB	12.700	14.541	-0.	55.2	50.9	3.4	288.2	1.199	10.13	1.800

RP	ABS VEL		REL VEL		MERID VEL		TANG VEL		WHEEL SPEED	
	IN	OUT	IN	OUT	IN	OUT	IN	OUT	IN	OUT
TIP	192.1	228.5	464.5	282.3	192.1	146.7	0.	175.3	422.9	416.5
1	197.2	226.6	458.8	284.1	197.2	152.1	-0.	168.0	414.2	407.9
2	201.9	226.0	452.5	283.1	201.9	156.2	0.	163.2	405.0	399.3
3	211.8	230.6	423.5	259.4	211.8	162.9	0.	163.2	366.8	365.1
4	212.2	235.9	402.5	240.6	212.2	165.0	0.	168.6	342.0	343.7
5	211.8	237.1	398.1	236.7	211.8	165.3	0.	170.0	337.0	339.4
6	211.4	238.4	393.6	232.8	211.4	165.6	0.	171.5	332.0	335.1
7	210.8	239.8	389.0	228.9	210.8	165.9	0.	173.2	326.9	330.8
8	210.1	241.3	384.3	225.0	210.1	166.2	0.	174.9	321.8	326.5
9	202.0	253.0	349.2	199.3	202.0	168.0	0.	189.2	284.8	296.6
10	185.3	272.3	302.4	173.2	185.3	166.7	0.	215.3	239.0	262.3
11	179.9	279.1	289.4	167.9	179.9	165.4	0.	224.8	226.7	253.7
HUB	174.2	286.8	276.0	164.1	174.2	163.8	-0.	235.4	214.1	245.2

RP	ABS MACH NO		REL MACH NO		MERID MACH NO		STREAMLINE SLOPE		MERID PEAK SS	
	IN	OUT	IN	OUT	IN	OUT	IN	OUT	VEL R	MACH NO
TIP	0.583	0.623	1.411	0.770	0.583	0.400	-6.70	-6.64	0.764	1.599
1	0.600	0.622	1.396	0.779	0.600	0.417	-5.93	-5.61	0.771	1.573
2	0.615	0.623	1.380	0.780	0.615	0.431	-5.03	-4.53	0.774	1.562
3	0.648	0.642	1.296	0.722	0.648	0.454	-0.48	0.09	0.769	1.538
4	0.649	0.660	1.232	0.673	0.649	0.461	2.76	3.15	0.778	1.518
5	0.648	0.664	1.218	0.663	0.648	0.463	3.44	3.79	0.780	1.513
6	0.647	0.668	1.204	0.652	0.647	0.464	4.14	4.44	0.783	1.508
7	0.645	0.673	1.190	0.642	0.645	0.465	4.85	5.10	0.787	1.502
8	0.643	0.677	1.175	0.631	0.643	0.466	5.57	5.77	0.791	1.496
9	0.616	0.715	1.065	0.563	0.616	0.474	11.25	10.87	0.831	1.459
10	0.562	0.775	0.916	0.493	0.562	0.474	19.98	17.83	0.900	1.307
11	0.544	0.796	0.876	0.479	0.544	0.472	22.91	19.78	0.919	1.233
HUB	0.526	0.820	0.833	0.469	0.526	0.468	26.15	21.80	0.941	1.154

RP	PERCENT		INCIDENCE		DEV	D-FACT	EFF	LOSS COEFF		LOSS PARAM	
	SPAN		MEAN	SS				TOT	PROF	TOT	PROF
TIP	0.	2.5	0.0		6.2	0.519	0.725	0.256	0.154	0.045	0.027
1	5.00	2.7	-0.0		5.7	0.501	0.772	0.207	0.111	0.037	0.020
2	10.00	3.0	0.0		5.3	0.490	0.811	0.168	0.078	0.030	0.014
3	30.00	4.1	-0.0		4.8	0.501	0.888	0.102	0.030	0.019	0.006
4	42.50	4.7	-0.0		4.9	0.518	0.913	0.083	0.024	0.016	0.005
5	45.00	4.9	-0.0		5.0	0.522	0.917	0.080	0.024	0.015	0.005
6	47.50	5.0	-0.0		5.1	0.526	0.920	0.078	0.024	0.015	0.005
7	50.00	5.1	-0.0		5.2	0.530	0.923	0.076	0.025	0.015	0.005
8	52.50	5.3	-0.0		5.3	0.534	0.926	0.074	0.027	0.014	0.005
9	70.00	6.2	-0.0		6.5	0.557	0.943	0.066	0.037	0.013	0.007
10	90.00	7.0	-0.0		9.3	0.572	0.937	0.090	0.087	0.017	0.016
11	95.00	7.2	-0.0		10.3	0.570	0.928	0.112	0.111	0.020	0.020
HUB	100.00	7.3	-0.0		11.3	0.562	0.916	0.142	0.142	0.024	0.024

TABLE III. - DESIGN BLADE-ELEMENT PARAMETERS FOR STATOR 8

RP	RAD II		ABS BETAM		REL BETAM		TOTAL TEMP		TOTAL PRESS	
	IN	OUT	IN	OUT	IN	OUT	IN	RATIO	IN	RATIO
TIP	24.384	24.384	45.2	0.	45.2	0.	360.8	1.001	18.24	0.956
1	23.944	23.948	42.9	-0.	42.9	-0.	356.4	1.000	18.24	0.966
2	23.505	23.539	41.4	0.	41.4	0.	353.1	1.000	18.24	0.973
3	21.741	21.902	40.0	0.	40.0	0.	347.5	1.000	18.24	0.980
4	20.634	20.884	40.4	0.	40.4	0.	345.8	1.000	18.24	0.978
5	20.413	20.681	40.6	0.	40.6	0.	345.6	1.000	18.24	0.978
6	20.192	20.480	40.7	0.	40.7	0.	345.4	1.000	18.24	0.978
7	19.972	20.279	40.9	0.	40.9	0.	345.2	1.000	18.24	0.977
8	19.751	20.079	41.0	0.	41.0	0.	345.0	1.000	18.24	0.977
9	18.221	18.715	42.3	0.	42.3	0.	344.0	1.000	18.24	0.973
10	16.521	17.252	44.9	0.	44.9	0.	344.4	1.000	18.24	0.955
11	16.110	16.904	45.9	0.	45.9	0.	344.9	1.000	18.24	0.942
HUB	15.697	16.485	46.9	-0.	46.9	-0.	345.6	1.000	18.24	0.924

RP	ABS VEL		REL VEL		MERID VEL		TANG VEL		WHEEL SPEED	
	IN	OUT	IN	OUT	IN	OUT	IN	OUT	IN	OUT
TIP	250.5	176.5	250.5	176.5	176.6	176.5	177.6	0.	0.	0.
1	249.2	181.1	249.2	181.1	182.5	181.1	169.7	-0.	0.	0.
2	248.9	184.5	248.9	184.5	186.9	184.5	164.5	0.	0.	0.
3	252.7	190.3	252.7	190.3	193.5	190.3	162.6	0.	0.	0.
4	256.8	191.6	256.8	191.6	195.5	191.6	166.5	0.	0.	0.
5	257.8	191.9	257.8	191.9	195.8	191.9	167.6	0.	0.	0.
6	258.9	192.3	258.9	192.3	196.3	192.3	168.8	0.	0.	0.
7	260.1	192.7	260.1	192.7	196.7	192.7	170.1	0.	0.	0.
8	261.3	193.1	261.3	193.1	197.1	193.1	171.5	0.	0.	0.
9	271.4	197.0	271.4	197.0	200.7	197.0	182.7	0.	0.	0.
10	287.3	196.9	287.3	196.9	203.6	196.9	202.7	0.	0.	0.
11	292.6	195.0	292.6	195.0	203.7	195.0	209.9	0.	0.	0.
HUB	298.5	192.1	298.5	192.1	203.8	192.1	218.1	-0.	0.	0.

RP	ABS MACH NO		REL MACH NO		MERID MACH NO		STREAMLINE SLOPE		MERID PEAK SS	
	IN	OUT	IN	OUT	IN	OUT	IN	OUT	VEL R	MACH NO
TIP	0.688	0.474	0.688	0.474	0.485	0.474	-0.32	-0.25	0.999	1.041
1	0.689	0.490	0.689	0.490	0.505	0.490	0.30	0.06	0.992	1.015
2	0.692	0.502	0.692	0.502	0.519	0.502	0.88	0.36	0.987	0.998
3	0.710	0.525	0.710	0.523	0.543	0.523	3.13	1.55	0.984	0.994
4	0.724	0.528	0.724	0.528	0.551	0.528	4.76	2.29	0.980	1.008
5	0.728	0.529	0.728	0.529	0.553	0.529	5.12	2.44	0.980	1.012
6	0.731	0.531	0.731	0.531	0.554	0.531	5.50	2.58	0.980	1.017
7	0.735	0.532	0.735	0.532	0.556	0.532	5.89	2.73	0.980	1.022
8	0.739	0.533	0.739	0.533	0.558	0.533	6.29	2.88	0.979	1.027
9	0.772	0.546	0.772	0.546	0.571	0.546	9.60	3.93	0.982	1.110
10	0.823	0.545	0.823	0.545	0.583	0.545	14.78	5.02	0.967	1.240
11	0.840	0.539	0.840	0.539	0.585	0.539	16.35	5.16	0.957	1.287
HUB	0.858	0.530	0.858	0.530	0.586	0.530	18.06	5.28	0.943	1.344

RP	PERCENT		INCIDENCE		DEV	D-FACT	EFF	LOSS COEFF		LOSS PARAM	
	SPAN	MEAN	SS	TOT				PROF	TOT	PROF	
TIP	0.	6.1	-0.0	12.3	0.535	0.	0.169	0.169	0.057	0.057	
1	5.00	6.1	0.0	11.1	0.500	0.	0.124	0.124	0.041	0.041	
2	10.00	6.1	-0.0	10.2	0.474	0.	0.098	0.098	0.032	0.032	
3	30.00	6.1	0.0	9.0	0.441	0.	0.070	0.070	0.021	0.021	
4	42.50	6.1	0.0	8.7	0.439	0.	0.073	0.073	0.021	0.021	
5	45.00	6.1	0.0	8.7	0.439	0.	0.074	0.074	0.021	0.021	
6	47.50	6.1	0.0	8.7	0.440	0.	0.075	0.075	0.021	0.021	
7	50.00	6.1	0.0	8.6	0.440	0.	0.076	0.076	0.021	0.021	
8	52.50	6.1	0.0	8.6	0.440	0.	0.076	0.076	0.021	0.021	
9	70.00	6.1	0.0	8.2	0.443	0.	0.082	0.082	0.021	0.021	
10	90.00	6.0	0.0	8.1	0.474	0.	0.126	0.126	0.029	0.029	
11	95.00	5.9	0.0	8.2	0.491	0.	0.156	0.156	0.035	0.035	
HUB	100.00	6.0	0.1	8.2	0.513	0.	0.202	0.199	0.044	0.044	

TABLE IV. - BLADE GEOMETRY FOR ROTOR 8

RP	PERCENT RADII			BLADE ANGLES			DELTA INC	CONE ANGLE
	SPAN	RI	RO	KIC	KTC	KOC		
TIP	0.	25.082	24.701	62.92	60.67	52.34	2.49	-9.298
1	5.	24.568	24.193	61.67	59.64	51.79	2.72	-8.836
2	10.	24.021	23.685	60.41	58.43	51.04	2.98	-7.644
3	30.	21.754	21.653	55.93	52.88	46.27	4.06	-1.996
4	43.	20.287	20.383	53.47	49.53	41.81	4.74	1.771
5	45.	19.989	20.129	52.99	48.87	40.74	4.88	2.542
6	48.	19.690	19.875	52.52	48.23	39.60	5.01	3.325
7	50.	19.388	19.621	52.06	47.59	38.38	5.15	4.114
8	53.	19.085	19.367	51.60	46.97	37.09	5.28	4.908
9	70.	16.891	17.589	48.50	42.58	26.07	6.19	10.851
10	90.	14.175	15.557	45.39	39.25	6.42	7.05	18.759
11	95.	13.447	15.049	44.77	38.97	-0.40	7.20	20.972
HUB	100.	12.700	14.541	44.22	38.93	-7.94	7.32	23.205

RP	BLADE THICKNESSES			AXIAL DIMENSIONS			
	TI	TM	TO	ZIC	ZMC	ZTC	ZOC
TIP	0.051	0.152	0.051	1.020	2.104	2.330	3.347
1	0.051	0.162	0.051	0.970	2.098	2.290	3.379
2	0.051	0.172	0.051	0.918	2.094	2.246	3.417
3	0.051	0.216	0.051	0.723	2.082	2.039	3.598
4	0.051	0.244	0.051	0.609	2.072	1.879	3.715
5	0.051	0.250	0.051	0.586	2.069	1.844	3.739
6	0.051	0.256	0.051	0.564	2.066	1.808	3.764
7	0.051	0.262	0.051	0.542	2.063	1.772	3.789
8	0.051	0.267	0.051	0.519	2.050	1.734	3.815
9	0.051	0.309	0.051	0.354	2.032	1.439	4.000
10	0.051	0.359	0.051	0.138	1.977	1.037	4.208
11	0.051	0.373	0.051	0.071	1.958	0.920	4.253
HUB	0.051	0.387	0.051	0.000	1.935	0.797	4.295

RP	AERO SETTING TOTAL			X			AREA RATIO
	CHORD	ANGLE	CAMBER	SOLIDITY	FACTOR	PHISS	
TIP	4.722	59.68	10.57	1.479	0.628	5.23	1.040
1	4.729	58.59	9.88	1.513	0.646	5.19	1.038
2	4.726	57.37	9.37	1.545	0.676	5.33	1.037
3	4.715	51.92	9.66	1.694	0.844	6.97	1.032
4	4.714	48.21	11.66	1.808	0.896	8.07	1.029
5	4.716	47.42	12.25	1.833	0.901	8.28	1.028
6	4.717	46.61	12.93	1.860	0.904	8.47	1.026
7	4.719	45.78	13.68	1.887	0.904	8.65	1.025
8	4.722	44.93	14.51	1.915	0.902	8.82	1.024
9	4.766	38.06	22.42	2.156	0.887	9.99	1.017
10	4.915	27.89	38.97	2.578	0.753	9.75	1.009
11	4.982	24.74	45.17	2.727	0.695	9.25	1.008
HUB	5.068	21.32	52.16	2.902	0.626	8.56	1.007

TABLE V. - BLADE GEOMETRY FOR STATOR 8

RP	PERCENT RADII			BLADE ANGLES			DELTA INC	CONE ANGLE
	SPAN	RI	RO	KIC	KTC	KOC		
TIP	0.	24.384	24.384	39.07	31.42	-12.32	6.09	0.057
1	5.	23.944	23.948	36.81	30.11	-11.06	6.12	0.066
2	10.	23.505	23.539	35.23	29.21	-10.19	6.13	0.494
3	30.	21.741	21.902	33.91	28.71	-8.99	6.14	2.315
4	43.	20.634	20.884	34.34	29.24	-8.73	6.13	3.595
5	45.	20.413	20.681	34.48	29.39	-8.70	6.13	3.868
6	48.	20.192	20.480	34.63	29.54	-8.67	6.13	4.149
7	50.	19.972	20.279	34.80	29.71	-8.64	6.12	4.438
8	53.	19.751	20.079	34.98	29.88	-8.62	6.12	4.733
9	70.	18.221	18.715	36.43	29.64	-8.22	6.06	7.105
10	90.	16.521	17.252	39.40	30.32	-8.12	5.95	10.487
11	95.	16.110	16.904	40.55	30.61	-8.17	5.91	11.382
HUB	100.	15.697	16.485	41.86	30.95	-8.25	5.86	11.308

RP	BLADE THICKNESSES			AXIAL DIMENSIONS			
	TI	TM	TO	ZIC	ZMC	ZTC	ZOC
TIP	0.051	0.279	0.051	7.665	9.447	9.001	11.572
1	0.051	0.279	0.051	7.637	9.454	8.918	11.573
2	0.051	0.279	0.051	7.618	9.459	8.853	11.573
3	0.051	0.279	0.051	7.531	9.393	8.658	11.502
4	0.051	0.279	0.051	7.523	9.381	8.602	11.491
5	0.051	0.279	0.051	7.614	9.471	8.685	11.580
6	0.051	0.279	0.051	7.634	9.489	8.696	11.598
7	0.051	0.279	0.051	7.637	9.491	8.690	11.599
8	0.051	0.279	0.051	7.623	9.475	8.668	11.584
9	0.051	0.279	0.051	7.606	9.460	8.580	11.569
10	0.051	0.279	0.051	7.616	9.456	8.522	11.567
11	0.051	0.279	0.051	7.621	9.455	8.512	11.566
HUB	0.051	0.279	0.051	7.628	9.453	8.504	11.566

RP	AERO SETTING			TOTAL SOLIDITY	X FACTOR	PHISS	AREA RATIO
	CHORD	ANGLE	CAMBER				
TIP	4.194	19.41	51.39	1.478	0.600	12.27	1.164
1	4.193	18.17	47.87	1.505	0.600	11.08	1.145
2	4.194	17.33	45.42	1.532	0.600	10.21	1.131
3	4.197	16.54	42.91	1.653	0.600	9.02	1.102
4	4.202	16.71	43.07	1.740	0.600	8.77	1.087
5	4.203	16.78	43.18	1.758	0.600	8.74	1.084
6	4.204	16.85	43.30	1.777	0.600	8.72	1.081
7	4.205	16.92	43.44	1.796	0.600	8.69	1.078
8	4.207	17.01	43.60	1.815	0.600	8.68	1.075
9	4.223	16.83	44.65	1.965	0.706	10.08	1.069
10	4.258	17.27	47.53	2.167	0.826	12.08	1.073
11	4.270	17.49	48.72	2.223	0.863	12.86	1.078
HUB	4.267	17.75	50.11	2.279	0.903	13.75	1.086

TABLE VI. - OVERALL PERFORMANCE FOR STAGE 8-8

(a) 100 Percent of design speed

Parameter	Reading					
	58	66	59	60	61	62
ROTOR TOTAL PRESSURE RATIO	1.677	1.711	1.773	1.810	1.845	1.856
STAGE TOTAL PRESSURE RATIO	1.536	1.643	1.712	1.738	1.760	1.757
ROTOR TOTAL TEMPERATURE RATIO	1.187	1.194	1.204	1.213	1.222	1.229
STAGE TOTAL TEMPERATURE RATIO	1.185	1.193	1.203	1.210	1.222	1.228
ROTOR TEMP. RISE EFFICIENCY	0.853	0.855	0.872	0.868	0.860	0.843
STAGE TEMP. RISE EFFICIENCY	0.705	0.792	0.819	0.812	0.791	0.767
ROTOR MOMENTUM RISE EFFICIENCY	0.831	0.843	0.881	0.878	0.873	0.862
ROTOR HEAD RISE COEFFICIENT	0.263	0.271	0.294	0.305	0.314	0.317
STAGE HEAD RISE COEFFICIENT	0.215	0.249	0.274	0.283	0.288	0.287
FLOW COEFFICIENT	0.429	0.427	0.422	0.412	0.394	0.374
WT FLOW PER UNIT FRONTAL AREA	151.14	151.06	149.01	146.36	142.04	136.47
WT FLOW PER UNIT ANNULUS AREA	203.26	203.15	200.39	196.83	191.02	183.53
WT FLOW AT ORIFICE	29.87	29.86	29.45	28.95	28.07	26.97
WT FLOW AT ROTOR INLET	30.25	30.18	29.87	29.34	28.47	27.35
WT FLOW AT ROTOR OUTLET	30.21	29.91	29.91	29.29	28.45	27.33
WT FLOW AT STATOR OUTLET	32.39	29.95	29.90	29.16	28.18	27.02
ROTATIVE SPEED	15950.2	16018.3	15935.0	15932.0	15977.7	15979.7
PERCENT OF DESIGN SPEED	99.1	99.5	99.0	99.0	99.2	99.3

(b) 90 Percent of design speed

Parameter	Reading				
	69	70	71	72	73
ROTOR TOTAL PRESSURE RATIO	1.535	1.579	1.613	1.641	1.648
STAGE TOTAL PRESSURE RATIO	1.469	1.538	1.567	1.591	1.590
ROTOR TOTAL TEMPERATURE RATIO	1.149	1.157	1.165	1.174	1.181
STAGE TOTAL TEMPERATURE RATIO	1.148	1.156	1.163	1.174	1.180
ROTOR TEMP. RISE EFFICIENCY	0.873	0.888	0.888	0.874	0.847
STAGE TEMP. RISE EFFICIENCY	0.785	0.841	0.838	0.817	0.786
ROTOR MOMENTUM RISE EFFICIENCY	0.863	0.882	0.888	0.880	0.860
ROTOR HEAD RISE COEFFICIENT	0.262	0.280	0.294	0.307	0.311
STAGE HEAD RISE COEFFICIENT	0.234	0.263	0.275	0.286	0.287
FLOW COEFFICIENT	0.429	0.421	0.406	0.379	0.352
WT FLOW PER UNIT FRONTAL AREA	140.58	138.31	134.60	127.58	119.78
WT FLOW PER UNIT ANNULUS AREA	189.06	186.00	181.01	171.57	161.09
WT FLOW AT ORIFICE	27.79	27.34	26.60	25.22	23.68
WT FLOW AT ROTOR INLET	28.13	27.68	26.95	25.49	23.93
WT FLOW AT ROTOR OUTLET	28.23	27.74	27.10	25.52	23.86
WT FLOW AT STATOR OUTLET	29.35	27.96	27.01	25.51	23.97
ROTATIVE SPEED	14442.1	14442.0	14452.1	14417.9	14384.6
PERCENT OF DESIGN SPEED	89.7	89.7	89.8	89.6	89.3

(c) 80 Percent of design speed

Parameter	Reading
	81
ROTOR TOTAL PRESSURE RATIO	1.473
STAGE TOTAL PRESSURE RATIO	1.439
ROTOR TOTAL TEMPERATURE RATIO	1.141
STAGE TOTAL TEMPERATURE RATIO	1.140
ROTOR TEMP. RISE EFFICIENCY	0.830
STAGE TEMP. RISE EFFICIENCY	0.781
ROTOR MOMENTUM RISE EFFICIENCY	0.840
ROTOR HEAD RISE COEFFICIENT	0.299
STAGE HEAD RISE COEFFICIENT	0.279
FLOW COEFFICIENT	0.330
WT FLOW PER UNIT FRONTAL AREA	102.15
WT FLOW PER UNIT ANNULUS AREA	137.37
WT FLOW AT ORIFICE	20.19
WT FLOW AT ROTOR INLET	20.47
WT FLOW AT ROTOR OUTLET	20.55
WT FLOW AT STATOR OUTLET	20.84
ROTATIVE SPEED	12824.1
PERCENT OF DESIGN SPEED	79.7

TABLE VI. - Concluded. OVERALL PERFORMANCE FOR STAGE 8-8

(d) 70 Percent of design speed

Parameter	Reading				
	74	75	76	77	78
ROTOR TOTAL PRESSURE RATIO	1.248	1.269	1.299	1.328	1.342
STAGE TOTAL PRESSURE RATIO	1.160	1.231	1.268	1.298	1.306
ROTOR TOTAL TEMPERATURE RATIO	1.072	1.078	1.086	1.097	1.106
STAGE TOTAL TEMPERATURE RATIO	1.072	1.077	1.086	1.095	1.104
ROTOR TEMP. RISE EFFICIENCY	0.903	0.909	0.901	0.873	0.829
STAGE TEMP. RISE EFFICIENCY	0.601	0.790	0.821	0.810	0.764
ROTOR MOMENTUM RISE EFFICIENCY	0.914	0.913	0.919	0.890	0.857
ROTOR HEAD RISE COEFFICIENT	0.219	0.236	0.260	0.282	0.293
STAGE HEAD RISE COEFFICIENT	0.145	0.204	0.235	0.258	0.265
FLOW COEFFICIENT	0.442	0.427	0.402	0.364	0.324
WT FLOW PER UNIT FRONTAL AREA	117.54	114.20	107.97	99.11	88.94
WT FLOW PER UNIT ANNULUS AREA	158.07	153.57	145.20	133.28	119.60
WT FLOW AT ORIFICE	23.23	22.57	21.34	19.59	17.58
WT FLOW AT ROTOR INLET	23.44	22.80	21.60	19.80	17.83
WT FLOW AT ROTOR OUTLET	23.78	23.03	21.86	20.02	17.86
WT FLOW AT STATOR OUTLET	23.97	22.19	20.85	19.16	17.23
ROTATIVE SPEED	11191.1	11207.5	11196.3	11203.4	11207.4
PERCENT OF DESIGN SPEED	69.5	69.6	69.5	69.6	69.6

(e) 60 Percent of design speed

(f) 50 Percent of design speed

Parameter	Reading	Parameter	Reading
	82		83
ROTOR TOTAL PRESSURE RATIO	1.242	ROTOR TOTAL PRESSURE RATIO	1.163
STAGE TOTAL PRESSURE RATIO	1.223	STAGE TOTAL PRESSURE RATIO	1.151
ROTOR TOTAL TEMPERATURE RATIO	1.077	ROTOR TOTAL TEMPERATURE RATIO	1.054
STAGE TOTAL TEMPERATURE RATIO	1.076	STAGE TOTAL TEMPERATURE RATIO	1.053
ROTOR TEMP. RISE EFFICIENCY	0.823	ROTOR TEMP. RISE EFFICIENCY	0.825
STAGE TEMP. RISE EFFICIENCY	0.776	STAGE TEMP. RISE EFFICIENCY	0.768
ROTOR MOMENTUM RISE EFFICIENCY	0.842	ROTOR MOMENTUM RISE EFFICIENCY	0.841
ROTOR HEAD RISE COEFFICIENT	0.291	ROTOR HEAD RISE COEFFICIENT	0.289
STAGE HEAD RISE COEFFICIENT	0.270	STAGE HEAD RISE COEFFICIENT	0.269
FLOW COEFFICIENT	0.310	FLOW COEFFICIENT	0.303
WT FLOW PER UNIT FRONTAL AREA	73.43	WT FLOW PER UNIT FRONTAL AREA	60.45
WT FLOW PER UNIT ANNULUS AREA	98.75	WT FLOW PER UNIT ANNULUS AREA	81.30
WT FLOW AT ORIFICE	14.51	WT FLOW AT ORIFICE	11.95
WT FLOW AT ROTOR INLET	14.78	WT FLOW AT ROTOR INLET	12.17
WT FLOW AT ROTOR OUTLET	14.95	WT FLOW AT ROTOR OUTLET	12.29
WT FLOW AT STATOR OUTLET	14.75	WT FLOW AT STATOR OUTLET	12.07
ROTATIVE SPEED	9586.4	ROTATIVE SPEED	8010.8
PERCENT OF DESIGN SPEED	59.5	PERCENT OF DESIGN SPEED	49.8

TABLE VII. - BLADE-ELEMENT DATA AT BLADE EDGES FOR ROTOR 8

(a) 100 Percent of design speed; reading 58

RP	RADII		ABS BETAM		REL BETAM		TOTAL TEMP		TOTAL PRESS	
	IN	OUT	IN	OUT	IN	OUT	IN	RATIO	IN	RATIO
1	24.567	24.193	0.0	41.1	64.0	55.2	288.7	1.220	9.98	1.725
2	24.021	23.685	0.0	39.7	62.4	54.2	288.5	1.204	10.10	1.703
3	21.753	21.653	0.0	39.2	58.9	47.7	288.2	1.191	10.15	1.717
4	20.287	20.383	0.0	44.0	56.9	44.1	288.0	1.188	10.15	1.648
5	19.990	20.129	0.0	44.5	56.5	44.2	288.1	1.186	10.14	1.622
6	19.690	19.875	0.0	44.8	56.2	45.2	288.0	1.180	10.15	1.589
7	19.388	19.621	0.0	45.0	55.8	44.9	287.9	1.176	10.15	1.579
8	19.086	19.367	0.0	44.0	55.4	43.2	288.0	1.172	10.15	1.596
9	16.891	17.589	0.0	44.0	53.0	34.5	287.9	1.164	10.16	1.624
10	14.176	15.557	0.0	46.8	50.3	17.2	287.9	1.174	10.15	1.713
11	13.447	15.049	0.0	52.6	49.3	6.3	287.9	1.192	10.15	1.776

RP	ABS VEL		REL VEL		MERID VEL		TANG VEL		WHEEL SPEED	
	IN	OUT	IN	OUT	IN	OUT	IN	OUT	IN	OUT
1	199.6	232.2	456.0	306.2	199.6	174.9	0.1	152.7	410.2	404.0
2	209.9	231.6	452.4	304.7	209.9	178.1	0.1	148.1	400.9	395.3
3	219.0	244.0	424.1	280.7	219.0	189.1	0.1	154.2	363.3	361.7
4	220.6	244.6	404.2	245.1	220.6	176.0	0.1	169.8	338.8	340.4
5	220.6	240.8	400.0	239.8	220.6	171.8	0.1	168.8	333.7	336.1
6	220.5	234.2	396.1	235.7	220.5	166.2	0.1	165.1	329.2	332.3
7	220.2	232.5	391.8	231.8	220.2	164.3	0.1	164.5	324.1	328.0
8	219.5	236.1	387.0	233.1	219.5	169.9	0.1	164.0	318.9	323.6
9	212.7	247.4	353.5	215.8	212.7	177.9	0.1	172.0	282.5	294.1
10	196.6	276.3	307.7	198.0	196.6	189.2	0.1	201.4	236.8	250.8
11	192.7	291.5	295.7	178.1	192.7	177.0	0.1	231.6	224.3	251.0

RP	ABS MACH NO		REL MACH NO		MERID MACH NO		MERID PEAK SS VEL R MACH NO	
	IN	OUT	IN	OUT	IN	OUT		
1	0.607	0.642	1.387	0.847	0.607	0.484	0.876	1.548
2	0.641	0.645	1.382	0.849	0.641	0.496	0.849	1.526
3	0.672	0.687	1.301	0.791	0.672	0.533	0.863	1.506
4	0.678	0.690	1.242	0.692	0.678	0.497	0.798	1.483
5	0.678	0.679	1.228	0.676	0.678	0.485	0.778	1.477
6	0.677	0.661	1.217	0.665	0.677	0.469	0.754	1.473
7	0.676	0.657	1.203	0.655	0.676	0.464	0.746	1.466
8	0.674	0.669	1.188	0.661	0.674	0.482	0.774	1.459
9	0.651	0.707	1.082	0.617	0.651	0.508	0.836	1.413
10	0.598	0.796	0.936	0.570	0.598	0.545	0.962	1.272
11	0.586	0.838	0.899	0.512	0.586	0.509	0.918	1.195

RP	PERCENT SPAN	INCIDENCE		DEV	D-FACT	EFF	LOSS COEFF		LOSS PARAM	
		MEAN	SS				TOT	PROF	TOT	PROF
1	5.00	2.2	-0.5	3.2	0.438	0.765	0.202	0.113	0.038	0.021
2	10.00	1.8	-1.1	3.0	0.432	0.807	0.159	0.076	0.030	0.014
3	30.00	3.0	-1.1	1.4	0.445	0.873	0.108	0.041	0.022	0.008
4	42.50	3.5	-1.3	2.3	0.510	0.816	0.162	0.108	0.032	0.021
5	45.00	3.6	-1.3	3.5	0.516	0.799	0.177	0.126	0.035	0.025
6	47.50	3.7	-1.3	5.6	0.517	0.786	0.186	0.137	0.035	0.026
7	50.00	3.8	-1.4	6.5	0.520	0.791	0.181	0.135	0.034	0.025
8	52.50	3.9	-1.4	6.2	0.509	0.831	0.147	0.104	0.028	0.020
9	70.00	4.5	-1.6	8.4	0.505	0.905	0.092	0.068	0.018	0.013
10	90.00	5.1	-1.9	10.7	0.489	0.953	0.060	0.057	0.011	0.011
11	95.00	4.9	-2.3	6.6	0.549	0.930	0.103	0.102	0.019	0.019

TABLE VII. - Continued. BLADE-ELEMENT DATA AT BLADE EDGES

FOR ROTOR 8

(b) 100 Percent of design speed; reading 66

RP	RADII		ABS BETAM		REL BETAM		TOTAL TEMP		TOTAL PRESS	
	IN	OUT	IN	OUT	IN	OUT	IN	RATIO	IN	RATIO
1	24.567	24.193	0.0	42.7	64.3	55.0	288.8	1.234	9.96	1.765
2	24.021	23.685	0.0	41.5	62.4	54.5	288.5	1.213	10.11	1.729
3	21.753	21.653	0.0	40.7	59.1	47.8	288.1	1.198	10.15	1.747
4	20.287	20.383	0.0	44.8	57.1	44.2	288.1	1.195	10.15	1.689
5	19.990	20.129	0.0	45.4	56.6	44.5	288.1	1.192	10.16	1.661
6	19.690	19.875	0.0	45.5	56.3	45.0	288.2	1.188	10.15	1.633
7	19.388	19.621	0.0	45.5	55.9	45.1	287.9	1.184	10.16	1.620
8	19.086	19.367	0.0	45.0	55.6	43.6	288.1	1.179	10.15	1.634
9	16.891	17.589	0.0	45.0	53.2	35.2	287.9	1.170	10.16	1.659
10	14.176	15.557	0.0	49.8	50.8	18.2	287.8	1.179	10.15	1.738
11	13.447	15.049	0.0	53.1	49.8	7.7	287.8	1.197	10.15	1.824

RP	ABS VEL		REL VEL		MERID VEL		TANG VEL		WHEEL SPEED	
	IN	OUT	IN	OUT	IN	OUT	IN	OUT	IN	OUT
1	198.3	234.1	456.4	300.2	198.3	172.0	0.1	158.9	411.2	405.0
2	210.0	231.5	454.0	299.0	210.0	173.4	0.1	153.4	402.6	397.0
3	218.7	244.2	425.4	275.6	218.7	185.2	0.1	159.2	365.0	363.4
4	220.4	245.2	405.4	242.5	220.4	173.9	0.1	172.9	340.3	342.0
5	220.6	240.9	401.2	236.8	220.6	169.0	0.1	171.7	335.2	337.6
6	220.6	235.7	397.2	233.7	220.6	165.1	0.1	168.2	330.5	333.6
7	220.1	232.4	392.6	230.5	220.1	162.8	0.1	165.9	325.2	329.1
8	219.5	235.5	388.3	230.2	219.5	166.7	0.1	166.4	320.4	325.2
9	211.8	244.9	353.8	211.8	211.8	173.2	0.1	173.2	283.5	295.2
10	194.0	267.3	306.8	181.6	194.0	172.5	0.1	204.2	237.8	261.0
11	190.5	286.8	295.3	173.8	190.5	172.3	0.1	229.3	225.8	252.7

RP	ABS MACH NO		REL MACH NO		MERID MACH NO		MERID PEAK SS	
	IN	OUT	IN	OUT	IN	OUT	VEL R	MACH NO
1	0.603	0.644	1.388	0.826	0.603	0.473	0.867	1.555
2	0.642	0.643	1.387	0.830	0.642	0.481	0.826	1.533
3	0.671	0.686	1.305	0.774	0.671	0.520	0.847	1.515
4	0.677	0.690	1.245	0.682	0.677	0.489	0.789	1.491
5	0.677	0.677	1.232	0.666	0.677	0.475	0.766	1.484
6	0.677	0.663	1.220	0.657	0.677	0.464	0.749	1.479
7	0.676	0.654	1.206	0.649	0.676	0.458	0.740	1.471
8	0.674	0.665	1.192	0.650	0.674	0.471	0.759	1.466
9	0.648	0.697	1.083	0.603	0.648	0.493	0.818	1.420
10	0.590	0.765	0.933	0.520	0.590	0.494	0.889	1.284
11	0.578	0.821	0.897	0.498	0.578	0.493	0.905	1.209

RP	PERCENT SPAN		INCIDENCE MEAN		DEV	D-FACT	EFF	LOSS COEFF		LOSS PARAM	
	SPAN	MEAN	SS	TOT				PROF	TOT	PROF	
1	5.00	2.4	-0.3	3.1	0.456	0.753	0.222	0.132	0.042	0.025	
2	10.00	1.9	-1.1	3.4	0.450	0.796	0.172	0.087	0.032	0.016	
3	30.00	3.1	-0.9	1.5	0.462	0.873	0.111	0.042	0.022	0.008	
4	42.50	3.6	-1.1	2.4	0.520	0.831	0.153	0.097	0.030	0.019	
5	45.00	3.7	-1.2	3.8	0.527	0.810	0.172	0.119	0.033	0.023	
6	47.50	3.8	-1.2	5.5	0.526	0.799	0.181	0.130	0.034	0.025	
7	50.00	3.9	-1.3	6.7	0.525	0.805	0.175	0.128	0.033	0.024	
8	52.50	4.0	-1.3	6.6	0.520	0.841	0.143	0.098	0.027	0.019	
9	70.00	4.8	-1.4	9.1	0.517	0.916	0.084	0.058	0.016	0.011	
10	90.00	5.6	-1.5	11.7	0.543	0.954	0.061	0.057	0.011	0.011	
11	95.00	5.5	-1.7	8.1	0.562	0.948	0.078	0.077	0.014	0.014	

TABLE VII. - Continued. BLADE-ELEMENT DATA AT BLADE EDGES

FOR ROTOR 8

(c) 100 Percent of design speed; reading 59

RP	RADII		ABS BETAM		REL BETAM		TOTAL TEMP		TOTAL PRESS	
	IN	OUT	IN	OUT	IN	OUT	IN	RATIO	IN	RATIO
1	24.567	24.193	0.0	45.7	64.5	53.8	288.7	1.251	9.97	1.888
2	24.021	23.685	0.0	42.4	62.8	53.3	288.6	1.231	10.12	1.845
3	21.753	21.653	0.0	43.5	59.4	48.2	288.1	1.207	10.15	1.803
4	20.287	20.383	0.0	46.3	57.4	43.9	288.0	1.202	10.16	1.760
5	19.990	20.129	0.0	46.9	57.0	44.1	288.1	1.200	10.15	1.731
6	19.690	19.875	0.1	46.9	56.6	44.5	288.0	1.197	10.15	1.705
7	19.388	19.621	0.1	47.5	56.2	44.0	288.3	1.194	10.15	1.693
8	19.086	19.367	0.1	46.8	55.8	43.0	287.9	1.189	10.15	1.696
9	16.891	17.589	0.1	46.3	53.5	35.9	287.9	1.175	10.15	1.687
10	14.176	15.557	0.1	51.5	51.1	18.4	287.9	1.180	10.15	1.741
11	13.447	15.049	0.1	53.0	50.1	8.2	287.9	1.200	10.15	1.844

RP	ABS VEL		REL VEL		MERID VEL		TANG VEL		WHEEL SPEED	
	IN	OUT	IN	OUT	IN	OUT	IN	OUT	IN	OUT
1	195.2	242.1	454.1	285.9	195.2	169.0	0.1	173.3	410.1	433.9
2	206.4	237.3	451.1	293.8	206.4	175.4	0.1	159.9	401.2	395.6
3	214.5	241.0	421.4	262.2	214.5	174.9	0.1	165.8	362.8	361.1
4	216.4	245.0	401.5	234.9	216.4	169.3	0.1	177.2	338.3	339.9
5	216.6	241.2	397.7	229.7	216.6	164.9	0.1	176.0	333.6	335.9
6	216.5	236.7	392.9	226.4	216.5	161.6	0.5	172.9	328.4	331.5
7	216.6	235.6	389.0	221.4	216.6	159.1	0.5	173.7	323.7	327.6
8	216.0	236.5	384.5	221.4	216.0	162.0	0.5	172.3	318.5	323.3
9	208.1	239.9	349.9	204.7	208.1	165.8	0.5	173.4	281.9	293.5
10	190.5	262.1	303.4	171.8	190.5	163.0	0.4	205.2	236.5	259.6
11	187.2	283.7	291.8	172.6	187.2	170.8	0.4	226.5	224.3	251.1

RP	ABS MACH NO		REL MACH NO		MERID MACH NO		MERID PEAK SS VEL R MACH NO	
	IN	OUT	IN	OUT	IN	OUT		
1	0.593	0.663	1.379	0.783	0.593	0.463	0.866	1.557
2	0.630	0.655	1.376	0.810	0.630	0.484	0.850	1.534
3	0.657	0.673	1.291	0.733	0.657	0.489	0.816	1.513
4	0.663	0.687	1.231	0.659	0.663	0.475	0.782	1.490
5	0.664	0.676	1.219	0.644	0.664	0.462	0.761	1.485
6	0.664	0.663	1.205	0.635	0.664	0.453	0.746	1.476
7	0.664	0.660	1.192	0.621	0.664	0.446	0.735	1.469
8	0.662	0.665	1.179	0.623	0.662	0.456	0.750	1.463
9	0.636	0.680	1.070	0.580	0.636	0.470	0.797	1.423
10	0.578	0.748	0.921	0.490	0.578	0.465	0.856	1.278
11	0.568	0.810	0.885	0.493	0.568	0.488	0.913	1.202

RP	PERCENT SPAN		INCIDENCE		DEV	D-FACT	EFF	LOSS COEFF		LOSS PARAM	
			MEAN	SS				TOT	PROF	TOT	PROF
1	5.00	2.7	0.0	0.0	1.8	0.495	0.793	0.199	0.110	0.039	0.022
2	10.00	2.2	-0.7	0.0	2.1	0.463	0.829	0.157	0.073	0.030	0.014
3	30.00	3.5	-0.6	0.0	1.9	0.493	0.885	0.106	0.039	0.021	0.008
4	42.50	3.9	-0.8	0.0	2.1	0.537	0.866	0.128	0.074	0.025	0.015
5	45.00	4.0	-0.9	0.0	3.4	0.544	0.848	0.145	0.094	0.028	0.018
6	47.50	4.1	-0.9	0.0	4.9	0.542	0.836	0.156	0.108	0.030	0.021
7	50.00	4.1	-1.0	0.0	5.7	0.550	0.836	0.157	0.112	0.030	0.021
8	52.50	4.2	-1.0	0.0	5.9	0.542	0.863	0.131	0.088	0.025	0.017
9	70.00	5.1	-1.1	0.0	9.9	0.532	0.919	0.084	0.060	0.016	0.011
10	90.00	5.9	-1.1	0.0	11.9	0.571	0.953	0.062	0.060	0.011	0.011
11	95.00	5.7	-1.5	0.0	8.5	0.559	0.957	0.067	0.067	0.012	0.012

TABLE VII. - Continued. BLADE-ELEMENT DATA AT BLADE EDGES

FOR ROTOR 8

(d) 100 Percent of design speed; reading 60

RP	RADI I		ABS BETAM		REL BETAM		TOTAL TEMP		TOTAL PRESS	
	IN	OUT	IN	OUT	IN	OUT	IN	RATIO	IN	RATIO
1	24.567	24.193	0.1	49.5	65.5	53.4	288.6	1.272	9.95	1.939
2	24.021	23.685	0.1	45.9	63.5	52.8	288.5	1.243	10.11	1.886
3	21.753	21.653	0.1	45.6	60.1	48.4	288.2	1.215	10.15	1.830
4	20.287	20.383	0.1	47.8	58.2	44.2	288.1	1.208	10.15	1.796
5	19.990	20.129	0.1	48.4	57.8	43.6	288.0	1.207	10.15	1.788
6	19.690	19.875	0.1	48.9	57.3	43.2	288.3	1.207	10.15	1.768
7	19.388	19.621	0.1	49.4	57.0	43.0	288.0	1.204	10.15	1.752
8	19.086	19.367	0.1	48.7	56.6	42.1	287.9	1.199	10.15	1.751
9	16.891	17.589	0.1	48.4	54.2	35.3	288.0	1.184	10.16	1.727
10	14.176	15.557	0.1	51.5	51.7	19.4	287.8	1.185	10.16	1.757
11	13.447	15.049	0.1	54.6	50.6	6.7	287.9	1.201	10.15	1.868

RP	ABS VEL		REL VEL		MERID VEL		TANG VEL		WHEEL SPEED	
	IN	OUT	IN	OUT	IN	OUT	IN	OUT	IN	OUT
1	186.9	246.9	450.2	269.0	186.9	160.3	0.5	187.8	410.1	403.8
2	199.5	241.5	446.8	277.9	199.5	168.1	0.5	173.4	400.3	394.7
3	208.4	240.3	418.1	253.3	208.4	168.1	0.5	171.8	363.0	361.3
4	209.9	244.0	397.8	228.5	209.9	163.9	0.5	180.8	338.5	340.1
5	210.2	243.6	394.1	223.3	210.2	161.8	0.5	182.2	333.8	336.2
6	210.3	241.8	389.6	218.1	210.3	158.9	0.5	182.3	328.5	331.6
7	209.9	239.8	385.2	213.4	209.9	156.2	0.5	181.9	323.5	327.4
8	209.3	239.8	380.5	213.3	209.3	158.4	0.5	180.1	318.3	323.0
9	203.0	241.4	347.3	196.4	203.0	160.3	0.5	180.5	282.2	293.9
10	186.6	258.9	300.8	170.9	186.6	161.2	0.4	202.5	236.3	259.3
11	183.7	284.2	289.5	165.9	183.7	164.7	0.4	231.6	224.2	250.9

RP	ABS MACH NO		REL MACH NO		MERID MACH NO		MERID PEAK SS VEL R MACH NO
	IN	OUT	IN	OUT	IN	OUT	
1	0.566	0.671	1.364	0.731	0.566	0.436	0.858 1.574
2	0.607	0.664	1.360	0.764	0.607	0.462	0.843 1.542
3	0.637	0.669	1.278	0.705	0.637	0.468	0.807 1.525
4	0.642	0.682	1.216	0.639	0.642	0.458	0.781 1.533
5	0.643	0.681	1.205	0.625	0.643	0.452	0.769 1.499
6	0.643	0.675	1.191	0.609	0.643	0.444	0.755 1.491
7	0.642	0.670	1.178	0.597	0.642	0.437	0.744 1.485
8	0.640	0.672	1.164	0.598	0.640	0.444	0.757 1.479
9	0.619	0.682	1.059	0.555	0.619	0.453	0.790 1.441
10	0.566	0.736	0.912	0.486	0.566	0.459	0.864 1.283
11	0.556	0.811	0.877	0.474	0.556	0.470	0.897 1.207

RP	PERCENT SPAN	INCIDENCE		DEV	D-FACT	EFF	LOSS COEFF		LOSS PARAM	
		MEAN	SS				TOT	PROF	TOT	PROF
1	5.00	3.7	0.9	1.4	0.539	0.766	0.239	0.149	0.047	0.029
2	10.00	3.0	-0.0	1.6	0.502	0.817	0.175	0.092	0.034	0.018
3	30.00	4.2	0.1	2.2	0.515	0.875	0.119	0.052	0.023	0.010
4	42.50	4.7	-0.0	2.4	0.551	0.876	0.122	0.068	0.024	0.014
5	45.00	4.8	-0.1	2.9	0.559	0.873	0.127	0.075	0.025	0.015
6	47.50	4.8	-0.2	3.7	0.566	0.853	0.149	0.100	0.029	0.020
7	50.00	4.9	-0.2	4.6	0.571	0.851	0.151	0.105	0.029	0.020
8	52.50	5.1	-0.2	5.0	0.563	0.870	0.131	0.088	0.025	0.017
9	70.00	5.8	-0.4	9.2	0.557	0.918	0.090	0.064	0.017	0.012
10	90.00	6.5	-0.6	12.9	0.568	0.946	0.075	0.072	0.014	0.013
11	95.00	6.2	-1.0	7.1	0.582	0.975	0.040	0.040	0.007	0.007

TABLE VII. - Continued. BLADE-ELEMENT DATA AT BLADE EDGES

FOR ROTOR 8

(e) 100 Percent of design speed; reading 61.

RP	RADII		ABS BETAM		REL BETAM		TOTAL TEMP		TOTAL PRESS	
	IN	OUT	IN	OUT	IN	OUT	IN	RATIO	IN	RATIO
1	24.567	24.193	0.1	52.4	66.5	54.0	288.7	1.286	9.98	1.964
2	24.021	23.685	0.1	49.6	64.7	52.7	288.5	1.262	10.11	1.934
3	21.753	21.653	0.1	48.0	61.4	48.6	288.1	1.226	10.15	1.867
4	20.287	20.383	0.1	49.1	59.4	44.7	288.2	1.214	10.15	1.829
5	19.990	20.129	0.1	49.7	59.1	44.4	288.1	1.213	10.15	1.814
6	19.690	19.875	0.1	50.5	58.7	43.7	288.0	1.214	10.15	1.805
7	19.388	19.621	0.1	51.2	58.3	42.8	288.1	1.213	10.15	1.797
8	19.086	19.367	0.1	50.6	57.9	41.6	288.1	1.209	10.15	1.799
9	16.891	17.589	0.1	50.1	55.5	35.7	287.8	1.189	10.15	1.756
10	14.176	15.557	0.1	53.3	53.0	18.8	287.9	1.190	10.15	1.786
11	13.447	15.049	0.1	55.7	51.8	6.5	288.0	1.207	10.15	1.886

RP	ABS VEL		REL VEL		MERID VEL		TANG VEL		WHEEL SPEED	
	IN	OUT	IN	OUT	IN	OUT	IN	OUT	IN	OUT
1	178.3	247.9	447.7	257.4	178.3	151.2	0.4	196.5	411.1	404.8
2	190.0	245.6	444.1	263.1	190.0	159.3	0.5	186.9	401.9	396.3
3	197.8	241.2	413.9	244.3	197.8	161.5	0.5	179.1	364.0	362.4
4	199.9	242.6	393.2	223.8	199.9	159.0	0.5	183.2	339.1	340.7
5	200.0	241.2	389.2	218.1	200.0	155.9	0.5	184.0	334.3	336.6
6	200.0	241.0	385.2	212.1	200.0	153.2	0.5	186.1	329.6	332.7
7	199.9	241.6	380.7	206.1	199.9	151.3	0.5	188.4	324.4	328.4
8	199.7	242.4	376.2	205.9	199.7	154.0	0.5	187.2	319.2	323.9
9	194.4	239.9	342.8	189.6	194.4	154.0	0.4	184.0	282.8	294.5
10	178.5	258.8	296.5	163.3	178.5	154.6	0.4	207.6	237.1	260.2
11	176.6	282.8	285.8	160.3	176.6	159.3	0.4	233.7	225.1	251.9

RP	ABS MACH NO		REL MACH NO		MERID MACH NO		MERID PEAK SS	
	IN	OUT	IN	OUT	IN	OUT	VEL R	MACH NO
1	0.539	0.670	1.352	0.696	0.539	0.409	0.848	1.598
2	0.576	0.670	1.347	0.718	0.576	0.435	0.839	1.570
3	0.602	0.668	1.260	0.677	0.602	0.448	0.816	1.554
4	0.609	0.676	1.198	0.623	0.609	0.443	0.795	1.531
5	0.609	0.672	1.186	0.608	0.609	0.434	0.779	1.527
6	0.609	0.672	1.174	0.591	0.609	0.427	0.766	1.523
7	0.609	0.673	1.159	0.574	0.609	0.422	0.757	1.516
8	0.608	0.677	1.146	0.575	0.608	0.430	0.771	1.509
9	0.591	0.676	1.043	0.534	0.591	0.434	0.792	1.475
10	0.540	0.734	0.897	0.463	0.540	0.439	0.866	1.302
11	0.534	0.804	0.864	0.456	0.534	0.453	0.902	1.224

RP	PERCENT SPAN	INCIDENCE		DEV	D-FACT	EFF	LOSS COEFF		LOSS PARAM	
		MEAN	SS				TOT	PROF	TOT	PROF
1	5.00	4.7	2.0	2.1	0.569	0.744	0.273	0.178	0.053	0.035
2	10.00	4.2	1.2	1.5	0.542	0.791	0.213	0.126	0.042	0.025
3	30.00	5.5	1.4	2.3	0.537	0.865	0.136	0.065	0.026	0.013
4	42.50	6.0	1.3	3.0	0.560	0.878	0.125	0.068	0.025	0.013
5	45.00	6.1	1.2	3.7	0.569	0.870	0.135	0.081	0.026	0.016
6	47.50	6.2	1.2	4.2	0.580	0.859	0.148	0.096	0.029	0.019
7	50.00	6.3	1.1	4.4	0.590	0.856	0.153	0.104	0.030	0.020
8	52.50	6.4	1.1	4.6	0.583	0.876	0.133	0.087	0.026	0.017
9	70.00	7.0	0.8	9.6	0.574	0.922	0.089	0.060	0.017	0.011
10	90.00	7.8	0.7	12.3	0.591	0.951	0.071	0.068	0.013	0.012
11	95.00	7.4	0.2	6.9	0.597	0.962	0.063	0.062	0.011	0.011

TABLE VII. - Continued. BLADE-ELEMENT DATA AT BLADE EDGES

FOR ROTOR 8

(f) 100 Percent of design speed; reading 62

RP	RADII		ABS BETAM		REL BETAM		TOTAL TEMP		TOTAL PRESS	
	IN	OUT	IN	OUT	IN	OUT	IN	RATIO	IN	RATIO
1	24.567	24.193	0.1	58.2	67.9	55.4	288.6	1.306	10.01	1.973
2	24.021	23.685	0.1	52.2	66.3	53.4	288.5	1.278	10.11	1.944
3	21.753	21.653	0.1	49.8	62.9	49.0	288.2	1.233	10.15	1.875
4	20.287	20.383	0.1	50.3	60.9	45.2	288.1	1.220	10.14	1.844
5	19.990	20.129	0.1	51.1	60.5	44.8	288.0	1.218	10.15	1.831
6	19.690	19.875	0.1	51.9	60.1	43.8	288.0	1.219	10.15	1.821
7	19.388	19.621	0.1	52.3	59.8	43.1	288.0	1.217	10.15	1.810
8	19.086	19.367	0.1	51.8	59.4	42.1	288.0	1.212	10.15	1.812
9	16.891	17.589	0.1	51.5	56.8	35.7	288.0	1.195	10.15	1.772
10	14.176	15.557	0.1	54.0	54.4	19.1	287.9	1.194	10.14	1.795
11	13.447	15.049	0.1	56.0	53.3	6.0	288.0	1.208	10.14	1.907

RP	ABS VEL		REL VEL		MERID VEL		TANG VEL		WHEEL SPEED	
	IN	OUT	IN	OUT	IN	OUT	IN	OUT	IN	OUT
1	167.2	250.9	443.4	232.9	167.2	132.3	0.4	213.2	411.1	404.8
2	176.3	245.4	438.4	252.2	176.3	150.5	0.4	193.8	401.8	396.2
3	186.1	240.8	408.5	236.6	186.1	155.3	0.5	184.0	364.1	362.4
4	188.9	241.6	388.1	218.8	188.9	154.3	0.5	185.9	359.4	341.0
5	189.2	240.6	384.2	213.0	189.2	151.2	0.5	187.1	334.8	337.2
6	189.0	241.1	379.4	206.4	189.0	148.9	0.4	189.6	329.5	332.6
7	188.8	240.6	374.8	201.5	188.8	147.1	0.5	190.4	324.2	328.1
8	188.7	241.1	370.5	201.0	188.7	149.2	0.5	189.4	319.3	324.1
9	184.7	239.4	337.4	183.6	184.7	149.1	0.4	187.3	282.7	294.4
10	169.5	257.2	291.3	159.8	169.5	151.1	0.4	208.2	237.3	260.5
11	167.7	283.5	280.3	159.2	167.7	158.4	0.4	235.1	224.9	251.8

RP	ABS MACH NO		REL MACH NO		MERID MACH NO		MERID PEAK SS	
	IN	OUT	IN	OUT	IN	OUT	VEL R	MACH NO
1	0.503	0.673	1.334	0.625	0.503	0.355	0.792	1.626
2	0.532	0.665	1.323	0.684	0.532	0.408	0.854	1.603
3	0.564	0.665	1.238	0.653	0.564	0.429	0.855	1.584
4	0.573	0.671	1.177	0.608	0.573	0.429	0.816	1.563
5	0.574	0.669	1.166	0.592	0.574	0.420	0.799	1.560
6	0.573	0.670	1.151	0.574	0.573	0.414	0.788	1.554
7	0.573	0.669	1.137	0.560	0.573	0.409	0.779	1.548
8	0.573	0.672	1.124	0.560	0.573	0.416	0.791	1.543
9	0.560	0.672	1.022	0.516	0.560	0.419	0.807	1.513
10	0.511	0.728	0.879	0.452	0.511	0.427	0.891	1.319
11	0.505	0.806	0.845	0.453	0.505	0.450	0.944	1.238

RP	PERCENT SPAN		INCIDENCE MEAN SS		DEV	D-FACT	EFF	LOSS COEFF		LOSS PARAM	
	SPAN	MEAN	SS	SS				TOT	PROF	TOT	PROF
1	5.00	6.0	3.3	3.4	0.632	0.699	0.336	0.238	0.063	0.045	
2	10.00	5.8	2.8	2.2	0.566	0.753	0.264	0.173	0.051	0.033	
3	30.00	7.0	2.9	2.7	0.553	0.844	0.162	0.089	0.031	0.017	
4	42.50	7.4	2.7	3.4	0.569	0.870	0.139	0.079	0.027	0.015	
5	45.00	7.5	2.7	4.1	0.579	0.864	0.147	0.088	0.028	0.017	
6	47.50	7.6	2.6	4.3	0.591	0.852	0.162	0.107	0.031	0.021	
7	50.00	7.7	2.6	4.8	0.597	0.850	0.166	0.114	0.032	0.022	
8	52.50	7.8	2.5	5.0	0.592	0.872	0.142	0.093	0.028	0.018	
9	70.00	8.3	2.1	9.6	0.587	0.913	0.104	0.073	0.020	0.014	
10	90.00	9.2	2.2	12.6	0.596	0.938	0.094	0.091	0.017	0.017	
11	95.00	8.9	1.7	6.3	0.594	0.973	0.046	0.046	0.008	0.008	

TABLE VII. - Continued. BLADE-ELEMENT DATA AT BLADE EDGES

FOR ROTOR 8

(g) 90 Percent of design speed; reading 69

RP	RADII		ABS BETAM		REL BETAM		TOTAL TEMP		TOTAL PRESS	
	IN	OUT	IN	OUT	IN	OUT	IN	RATIO	IN	RATIO
1	24.567	24.193	0.0	37.3	64.4	54.1	288.9	1.171	10.00	1.569
2	24.021	23.685	0.0	35.7	62.7	53.3	288.7	1.162	10.10	1.549
3	21.753	21.653	0.0	36.4	59.3	48.3	288.1	1.148	10.15	1.534
4	20.287	20.383	0.0	39.9	57.4	43.1	288.0	1.149	10.15	1.530
5	19.990	20.129	0.0	41.2	57.0	42.5	287.9	1.149	10.15	1.517
6	19.690	19.875	0.0	42.1	56.6	42.4	288.0	1.148	10.15	1.499
7	19.388	19.621	0.0	42.0	56.2	42.8	287.9	1.146	10.15	1.480
8	19.086	19.367	0.0	41.3	55.9	41.5	287.9	1.140	10.15	1.492
9	16.891	17.589	0.0	41.6	53.5	34.5	287.9	1.132	10.15	1.495
10	14.176	15.557	0.0	47.0	50.8	15.3	287.8	1.146	10.15	1.576
11	13.447	15.049	0.0	51.3	49.7	5.2	287.8	1.160	10.15	1.640

RP	ABS VEL		REL VEL		MERID VEL		TANG VEL		WHEEL SPEED	
	IN	OUT	IN	OUT	IN	OUT	IN	OUT	IN	OUT
1	177.9	214.4	411.6	291.0	177.9	170.6	0.0	129.8	371.2	365.5
2	187.2	213.7	408.4	290.6	187.2	173.5	0.0	124.8	363.0	357.9
3	195.3	218.7	382.3	264.4	195.3	176.0	0.0	129.9	328.7	327.2
4	196.6	226.8	364.5	238.2	196.6	173.9	0.0	145.6	307.0	308.4
5	196.5	225.7	360.4	230.5	196.5	169.9	0.0	148.6	302.2	304.3
6	196.2	223.1	356.6	224.1	196.2	165.5	0.0	149.6	297.9	300.7
7	196.2	218.8	353.2	221.8	196.2	162.6	0.0	146.4	293.7	297.2
8	195.7	221.5	349.0	221.9	195.7	166.3	0.0	146.3	289.0	293.3
9	189.0	225.8	317.6	204.8	189.0	168.9	0.0	150.0	255.3	265.8
10	174.8	256.7	276.7	181.6	174.8	175.2	0.0	187.6	214.5	235.4
11	172.6	271.6	266.7	170.5	172.6	169.8	0.0	212.1	203.4	227.6

RP	ABS MACH NO		REL MACH NO		MERID MACH NO		MERID PEAK SS	
	IN	OUT	IN	OUT	IN	OUT	VEL R	MACH NO
1	0.537	0.602	1.242	0.817	0.537	0.479	0.959	1.424
2	0.567	0.603	1.237	0.820	0.567	0.489	0.927	1.412
3	0.594	0.623	1.163	0.753	0.594	0.501	0.901	1.397
4	0.598	0.647	1.109	0.680	0.598	0.496	0.885	1.392
5	0.598	0.644	1.097	0.658	0.598	0.485	0.865	1.389
6	0.597	0.636	1.085	0.639	0.597	0.472	0.844	1.388
7	0.597	0.624	1.075	0.632	0.597	0.464	0.829	1.386
8	0.595	0.634	1.062	0.635	0.595	0.476	0.850	1.384
9	0.574	0.650	0.964	0.589	0.574	0.486	0.893	1.344
10	0.528	0.743	0.836	0.526	0.528	0.507	1.002	1.152
11	0.521	0.786	0.805	0.493	0.521	0.491	0.984	1.081

RP	PERCENT		INCIDENCE		DEV	D-FACT	EFF	LOSS COEFF		LOSS PARAM	
	SPAN	MEAN	SS	SS				TOT	PROF	TOT	PROF
1	5.00	2.6	-0.1	2.1	0.396	0.801	0.158	0.114	0.031	0.022	
2	10.00	2.2	-0.8	2.1	0.387	0.822	0.136	0.097	0.026	0.019	
3	30.00	3.3	-0.7	2.0	0.409	0.879	0.084	0.063	0.018	0.012	
4	42.50	3.9	-0.8	1.3	0.457	0.866	0.112	0.088	0.023	0.018	
5	45.00	4.0	-0.9	1.8	0.473	0.849	0.127	0.104	0.026	0.021	
6	47.50	4.1	-0.9	2.8	0.485	0.828	0.146	0.124	0.029	0.025	
7	50.00	4.2	-0.9	4.5	0.483	0.814	0.158	0.137	0.031	0.027	
8	52.50	4.3	-1.0	4.4	0.474	0.864	0.114	0.095	0.022	0.019	
9	70.00	5.0	-1.2	8.4	0.467	0.922	0.072	0.064	0.014	0.012	
10	90.00	5.6	-1.4	8.8	0.481	0.954	0.059	0.059	0.011	0.011	
11	95.00	5.3	-1.9	5.6	0.515	0.950	0.072	0.072	0.013	0.013	

TABLE VII. - Continued. BLADE-ELEMENT DATA AT BLADE EDGES

FOR ROTOR 8

(h) 90 Percent of design speed; reading 70

RP	RADII		ABS BETAM		REL BETAM		TOTAL TEMP		TOTAL PRESS	
	IN	OUT	IN	OUT	IN	OUT	IN	RATIO	IN	RATIO
1	24.567	24.193	0.0	41.1	64.9	53.4	288.8	1.189	10.00	1.639
2	24.021	23.685	0.0	39.1	63.2	53.1	288.7	1.172	10.11	1.608
3	21.753	21.653	0.0	39.4	59.8	48.3	288.0	1.156	10.15	1.582
4	20.287	20.383	0.0	41.8	57.9	43.6	288.0	1.154	10.15	1.569
5	19.990	20.129	0.0	42.6	57.6	43.1	288.0	1.154	10.15	1.560
6	19.690	19.875	0.0	43.7	57.2	42.6	288.0	1.155	10.15	1.548
7	19.388	19.621	0.0	44.1	56.8	42.4	288.0	1.153	10.15	1.534
8	19.086	19.367	0.0	43.2	56.5	41.4	288.0	1.148	10.14	1.540
9	16.891	17.589	0.0	43.9	54.1	34.9	287.9	1.139	10.15	1.525
10	14.176	15.557	0.0	48.7	51.7	16.3	287.9	1.148	10.14	1.595
11	13.447	15.049	0.0	52.0	50.6	6.6	287.9	1.162	10.14	1.659

RP	ABS VEL		REL VEL		MERID VEL		TANG VEL		WHEEL SPEED	
	IN	OUT	IN	OUT	IN	OUT	IN	OUT	IN	OUT
1	174.1	218.9	410.6	276.7	174.1	164.9	0.0	144.0	371.9	366.2
2	183.5	215.4	407.1	278.3	183.5	167.1	0.0	135.9	363.4	358.4
3	191.2	217.8	380.3	253.0	191.2	168.2	0.0	138.3	328.8	327.3
4	192.1	223.6	361.6	230.2	192.1	166.6	0.0	149.1	306.4	307.9
5	192.1	222.9	358.3	224.8	192.1	164.1	0.0	150.9	302.5	304.6
6	191.9	221.7	354.4	218.0	191.9	160.4	0.0	153.1	297.9	300.7
7	191.4	219.6	350.1	213.6	191.4	157.8	0.0	152.8	293.1	296.6
8	191.0	220.8	346.1	214.5	191.0	161.0	0.0	151.1	288.6	292.8
9	184.6	222.2	315.1	195.3	184.6	160.1	0.0	154.0	255.3	265.9
10	169.4	249.1	273.2	171.2	169.4	164.3	0.0	187.3	214.4	235.3
11	167.2	265.2	263.4	164.4	167.2	163.3	0.0	209.0	203.5	227.8

RP	ABS MACH NO		REL MACH NO		MERID MACH NO		MERID PEAK SS	
	IN	OUT	IN	OUT	IN	OUT	IN	OUT
1	0.525	0.611	1.238	0.772	0.525	0.460	0.947	1.438
2	0.555	0.605	1.232	0.782	0.555	0.469	0.911	1.414
3	0.581	0.618	1.155	0.718	0.581	0.477	0.880	1.410
4	0.584	0.636	1.099	0.655	0.584	0.474	0.867	1.404
5	0.584	0.634	1.089	0.639	0.584	0.467	0.854	1.405
6	0.583	0.630	1.077	0.620	0.583	0.456	0.836	1.403
7	0.582	0.624	1.063	0.607	0.582	0.449	0.824	1.401
8	0.580	0.629	1.051	0.612	0.580	0.459	0.843	1.399
9	0.559	0.636	0.955	0.559	0.559	0.458	0.867	1.353
10	0.511	0.718	0.824	0.493	0.511	0.474	0.970	1.160
11	0.504	0.764	0.794	0.474	0.504	0.471	0.976	1.091

RP	PERCENT SPAN	INCIDENCE		DEV	D-FACT	EFF	LOSS COEFF		LOSS PARAM	
		MEAN	SS				TOT	PROF	TOT	PROF
1	5.00	3.1	0.4	1.4	0.441	0.802	0.170	0.125	0.034	0.025
2	10.00	2.7	-0.3	1.9	0.424	0.843	0.127	0.086	0.025	0.017
3	30.00	3.9	-0.2	2.0	0.442	0.899	0.083	0.052	0.016	0.010
4	42.50	4.5	-0.3	1.8	0.478	0.893	0.093	0.068	0.019	0.014
5	45.00	4.6	-0.3	2.4	0.488	0.879	0.106	0.082	0.021	0.016
6	47.50	4.7	-0.3	3.1	0.501	0.861	0.124	0.102	0.025	0.020
7	50.00	4.8	-0.3	4.0	0.506	0.851	0.133	0.113	0.026	0.022
8	52.50	4.9	-0.4	4.3	0.495	0.890	0.098	0.078	0.019	0.015
9	70.00	5.7	-0.5	8.9	0.496	0.920	0.079	0.071	0.015	0.013
10	90.00	6.5	-0.5	9.8	0.512	0.963	0.049	0.049	0.009	0.009
11	95.00	6.2	-1.0	6.9	0.530	0.961	0.059	0.059	0.011	0.011

TABLE VII. - Continued. BLADE-ELEMENT DATA AT BLADE EDGES

FOR ROTOR 8

(i) 90 Percent of design speed; reading 71

RP	RADII		ABS BETAM		REL BETAM		TOTAL TEMP		TOTAL PRESS	
	IN	OUT	IN	OUT	IN	OUT	IN	RATIO	IN	RATIO
1	24.567	24.193	0.0	44.3	65.9	53.7	288.8	1.201	9.98	1.681
2	24.021	23.685	0.0	42.3	64.1	53.0	288.7	1.185	10.11	1.652
3	21.753	21.653	0.0	42.1	60.8	48.7	288.0	1.164	10.15	1.612
4	20.287	20.383	0.0	43.7	58.9	44.0	288.0	1.161	10.15	1.605
5	19.990	20.129	0.0	44.5	58.5	43.5	287.9	1.160	10.15	1.594
6	19.690	19.875	0.0	45.3	58.1	42.7	288.0	1.161	10.15	1.584
7	19.388	19.621	0.0	45.9	57.8	41.9	288.0	1.160	10.15	1.577
8	19.086	19.367	0.0	45.3	57.5	41.0	287.9	1.155	10.15	1.582
9	16.891	17.589	0.0	45.9	55.2	34.0	287.9	1.147	10.15	1.565
10	14.176	15.557	0.0	50.6	52.7	16.5	287.9	1.152	10.15	1.608
11	13.447	15.049	0.0	53.4	51.6	6.0	287.8	1.166	10.15	1.678

RP	ABS VEL		REL VEL		MERID VEL		TANG VEL		WHEEL SPEED	
	IN	OUT	IN	OUT	IN	OUT	IN	OUT	IN	OUT
1	166.1	218.7	407.0	264.6	166.1	156.6	0.0	152.7	371.5	365.9
2	176.6	216.8	404.5	266.6	176.6	160.4	0.0	145.9	363.9	358.9
3	183.7	215.9	376.7	243.1	183.7	160.3	0.0	144.6	328.9	327.4
4	185.5	222.4	358.8	223.4	185.5	160.8	0.0	153.6	307.2	308.6
5	185.2	221.3	354.9	217.4	185.2	157.7	0.0	155.2	302.8	304.9
6	185.2	221.1	350.9	211.7	185.2	155.4	0.0	157.2	298.1	300.9
7	184.6	220.8	346.4	206.5	184.6	153.6	0.0	158.6	293.1	296.6
8	184.2	221.8	342.8	206.8	184.2	156.1	0.0	157.7	289.1	293.4
9	177.7	224.1	311.2	188.1	177.7	156.0	0.0	160.9	255.5	266.1
10	163.3	245.0	269.7	162.1	163.3	155.4	0.0	189.4	214.7	235.6
11	161.4	263.0	259.6	157.6	161.4	156.8	0.0	211.2	203.3	227.6

RP	ABS MACH NO		REL MACH NO		MERID MACH NO		MERID PEAK SS	
	IN	OUT	IN	OUT	IN	OUT	VEL R	MACH NO
1	0.500	0.607	1.224	0.734	0.500	0.435	0.943	1.460
2	0.533	0.606	1.221	0.745	0.533	0.448	0.938	1.436
3	0.557	0.610	1.141	0.687	0.557	0.453	0.873	1.434
4	0.562	0.630	1.088	0.633	0.562	0.456	0.867	1.430
5	0.562	0.627	1.076	0.616	0.562	0.447	0.852	1.431
6	0.561	0.626	1.064	0.600	0.561	0.440	0.839	1.428
7	0.559	0.626	1.050	0.585	0.559	0.435	0.832	1.426
8	0.558	0.631	1.039	0.588	0.558	0.444	0.847	1.428
9	0.537	0.640	0.941	0.537	0.537	0.445	0.878	1.367
10	0.492	0.704	0.812	0.465	0.492	0.446	0.952	1.172
11	0.486	0.756	0.781	0.453	0.486	0.451	0.971	1.100

RP	PERCENT SPAN		INCIDENCE		DEV	D-FACT	EFF	LOSS COEFF		LOSS PARAM	
	SPAN	MEAN	SS	SS				TOT	PROF	TOT	PROF
1	5.00	4.1	1.4	1.7	0.473	0.798	0.185	0.137	0.036	0.027	
2	10.00	3.6	0.6	1.8	0.457	0.833	0.145	0.102	0.028	0.020	
3	30.00	4.9	0.8	2.5	0.468	0.891	0.095	0.061	0.018	0.012	
4	42.50	5.4	0.7	2.2	0.496	0.902	0.089	0.062	0.018	0.012	
5	45.00	5.6	0.7	2.8	0.507	0.889	0.103	0.077	0.020	0.015	
6	47.50	5.6	0.6	3.2	0.518	0.870	0.122	0.098	0.024	0.019	
7	50.00	5.8	0.6	3.6	0.526	0.871	0.123	0.100	0.024	0.020	
8	52.50	5.9	0.6	4.0	0.518	0.906	0.089	0.067	0.018	0.013	
9	70.00	6.7	0.5	7.9	0.518	0.931	0.073	0.064	0.014	0.012	
10	90.00	7.6	0.5	10.0	0.542	0.958	0.058	0.058	0.011	0.011	
11	95.00	7.2	-0.0	6.3	0.550	0.963	0.059	0.059	0.011	0.011	

TABLE VII. - Continued. BLADE-ELEMENT DATA AT BLADE EDGES

FOR ROTOR 8

(j) 90 Percent of design speed; reading 72

RP	RADII		ABS BETAM		REL BETAM		TOTAL TEMP		TOTAL PRESS	
	IN	OUT	IN	OUT	IN	OUT	IN	RATIO	IN	RATIO
1	24.567	24.193	0.0	50.4	67.6	54.4	289.2	1.217	10.00	1.718
2	24.021	23.685	0.0	47.8	65.9	53.3	289.0	1.203	10.11	1.696
3	21.753	21.653	0.0	45.9	62.6	49.2	288.0	1.175	10.15	1.646
4	20.287	20.383	0.0	46.3	60.7	44.5	287.9	1.167	10.15	1.637
5	19.990	20.129	0.0	47.2	60.3	43.7	288.0	1.167	10.15	1.632
6	19.690	19.875	0.0	48.3	60.0	43.2	287.9	1.169	10.15	1.618
7	19.388	19.621	0.0	48.8	59.7	42.3	287.9	1.168	10.15	1.616
8	19.086	19.367	0.0	48.3	59.3	41.4	287.8	1.163	10.16	1.612
9	16.891	17.589	0.0	48.9	57.0	35.8	287.8	1.150	10.15	1.574
10	14.176	15.557	0.0	51.6	54.6	18.6	287.7	1.154	10.15	1.615
11	13.447	15.049	0.0	54.9	53.3	5.9	287.8	1.167	10.14	1.691

RP	ABS VEL		REL VEL		MERID VEL		TANG VEL		WHEEL SPEED	
	IN	OUT	IN	OUT	IN	OUT	IN	OUT	IN	OUT
1	152.8	219.9	401.4	241.1	152.8	140.2	0.0	169.5	371.2	365.6
2	162.3	218.1	397.8	245.2	162.3	146.6	0.0	161.5	363.2	358.2
3	170.0	214.7	370.1	228.8	170.0	149.5	0.0	154.1	328.7	327.2
4	171.5	219.2	350.8	212.4	171.5	151.4	0.0	158.5	306.1	307.5
5	171.6	219.6	346.8	206.3	171.6	149.3	0.0	161.1	301.4	303.5
6	171.7	218.7	343.2	199.6	171.7	145.5	0.0	163.3	297.1	299.9
7	171.4	219.4	339.5	195.2	171.4	144.4	0.0	165.2	293.0	296.5
8	170.9	219.2	334.7	194.2	170.9	145.7	0.0	163.8	287.8	292.0
9	165.5	216.4	304.0	175.2	165.5	142.1	0.0	163.2	255.1	265.6
10	152.1	236.9	262.7	155.3	152.1	147.2	0.0	185.5	214.2	235.1
11	151.2	258.7	252.9	149.7	151.2	148.9	0.0	211.6	202.8	227.0

RP	ABS MACH NO		REL MACH NO		MERID MACH NO		MERID PEAK SS VEL R MACH NO	
	IN	OUT	IN	OUT	IN	OUT	IN	OUT
1	0.458	0.606	1.202	0.664	0.458	0.386	0.917	1.500
2	0.487	0.604	1.195	0.680	0.487	0.406	0.903	1.476
3	0.513	0.603	1.116	0.642	0.513	0.420	0.879	1.478
4	0.517	0.619	1.059	0.600	0.517	0.427	0.883	1.477
5	0.518	0.620	1.047	0.583	0.518	0.421	0.870	1.477
6	0.518	0.617	1.036	0.563	0.518	0.411	0.847	1.477
7	0.517	0.620	1.024	0.551	0.517	0.408	0.843	1.480
8	0.516	0.620	1.010	0.549	0.516	0.412	0.853	1.480
9	0.499	0.616	0.916	0.498	0.499	0.404	0.859	1.388
10	0.457	0.677	0.789	0.444	0.457	0.421	0.968	1.189
11	0.454	0.742	0.759	0.429	0.454	0.427	0.985	1.114

RP	PERCENT SPAN	INCIDENCE		DEV	D-FACT	EFF	LOSS COEFF		LOSS PARAM	
		MEAN	SS				TOT	PROF	TOT	PROF
1	5.00	5.8	3.1	2.5	0.538	0.770	0.227	0.175	0.044	0.034
2	10.00	5.4	2.4	2.1	0.514	0.802	0.188	0.142	0.036	0.027
3	30.00	6.7	2.6	2.9	0.504	0.873	0.119	0.082	0.023	0.016
4	42.50	7.3	2.5	2.8	0.520	0.903	0.095	0.064	0.019	0.013
5	45.00	7.4	2.5	3.0	0.532	0.898	0.101	0.072	0.020	0.014
6	47.50	7.5	2.5	3.6	0.547	0.874	0.127	0.099	0.025	0.019
7	50.00	7.6	2.5	3.9	0.555	0.877	0.125	0.098	0.025	0.019
8	52.50	7.7	2.4	4.3	0.549	0.895	0.107	0.082	0.021	0.016
9	70.00	8.6	2.4	9.7	0.551	0.924	0.085	0.076	0.016	0.014
10	90.00	9.4	2.4	12.1	0.552	0.951	0.071	0.071	0.013	0.013
11	95.00	8.9	1.7	6.2	0.570	0.971	0.048	0.048	0.009	0.009

TABLE VII. - Continued. BLADE-ELEMENT DATA AT BLADE EDGES

FOR ROTOR 8

(k) 90 Percent of design speed; reading 73

RP	RAD II		ABS BETAM		REL BETAM		TOTAL TEMP		TOTAL PRESS	
	IN	OUT	IN	OUT	IN	OUT	IN	RATIO	IN	RATIO
1	24.567	24.193	0.0	56.5	69.5	55.5	289.5	1.239	10.01	1.737
2	24.021	23.685	0.0	51.9	67.8	53.6	289.2	1.217	10.11	1.711
3	21.753	21.653	0.0	48.4	64.5	49.3	288.0	1.183	10.14	1.663
4	20.287	20.383	0.0	48.8	62.7	45.5	287.8	1.174	10.15	1.640
5	19.990	20.129	0.0	49.8	62.3	44.9	287.9	1.173	10.15	1.632
6	19.690	19.875	0.0	50.4	61.9	44.2	288.0	1.174	10.15	1.625
7	19.388	19.621	0.0	51.3	61.6	43.4	287.8	1.173	10.15	1.617
8	19.086	19.367	0.0	51.3	61.3	42.6	287.8	1.169	10.15	1.614
9	16.891	17.589	0.0	51.5	58.9	37.3	287.7	1.155	10.15	1.572
10	14.176	15.557	0.0	53.7	56.2	18.6	287.7	1.155	10.15	1.617
11	13.447	15.049	0.0	55.3	54.9	6.5	287.7	1.167	10.14	1.696

RP	ABS VEL		REL VEL		MERID VEL		TANG VEL		WHEEL SPEED	
	IN	OUT	IN	OUT	IN	OUT	IN	OUT	IN	OUT
1	138.4	223.1	395.6	217.3	138.4	123.2	0.0	186.0	370.6	365.0
2	147.9	219.7	390.8	228.4	147.9	135.6	0.0	172.9	361.7	356.7
3	156.3	214.5	362.9	218.6	156.3	142.5	0.0	160.3	327.6	326.1
4	157.7	215.5	343.5	202.6	157.7	142.0	0.0	162.1	305.2	306.7
5	157.7	215.4	339.6	196.3	157.7	139.2	0.0	164.4	300.8	302.9
6	158.2	215.4	336.1	191.2	158.2	137.2	0.0	166.1	296.5	299.3
7	158.0	215.2	331.8	185.2	158.0	134.5	0.0	168.0	291.8	295.3
8	157.6	215.2	327.7	182.7	157.6	134.5	0.0	168.0	287.3	291.5
9	153.2	210.9	297.0	164.8	153.2	131.2	0.0	165.2	254.4	264.9
10	143.2	233.6	257.4	145.8	143.2	138.2	0.0	188.3	213.8	234.7
11	142.5	256.0	248.0	146.5	142.5	145.5	0.0	210.5	202.9	227.1

RP	ABS MACH NO		REL MACH NO		MERID MACH NO		MERID PEAK SS	
	IN	OUT	IN	OUT	IN	OUT	VEL R	MACH NO
1	0.412	0.609	1.179	0.593	0.412	0.336	0.890	1.546
2	0.442	0.605	1.168	0.629	0.442	0.373	0.917	1.517
3	0.470	0.600	1.090	0.612	0.470	0.399	0.912	1.524
4	0.474	0.606	1.033	0.570	0.474	0.399	0.900	1.531
5	0.474	0.606	1.021	0.552	0.474	0.391	0.882	1.533
6	0.476	0.605	1.010	0.537	0.476	0.386	0.867	1.534
7	0.475	0.605	0.997	0.521	0.475	0.378	0.851	1.534
8	0.474	0.606	0.985	0.515	0.474	0.379	0.853	1.521
9	0.460	0.598	0.892	0.467	0.460	0.372	0.856	1.409
10	0.429	0.667	0.771	0.416	0.429	0.395	0.965	1.203
11	0.427	0.733	0.742	0.420	0.427	0.417	1.021	1.130

RP	PERCENT	INCIDENCE		DEV	D-FACT	EFF	LOSS COEFF		LOSS PARAM	
	SPAN	MEAN	SS				TOT	PROF	TOT	PROF
1	5.00	7.7	5.0	3.5	0.605	0.715	0.305	0.247	0.057	0.046
2	10.00	7.3	4.3	2.4	0.558	0.765	0.240	0.189	0.046	0.036
3	30.00	8.5	4.5	3.0	0.528	0.855	0.145	0.103	0.028	0.020
4	42.50	9.2	4.5	3.7	0.541	0.871	0.133	0.097	0.026	0.019
5	45.00	9.4	4.5	4.1	0.554	0.866	0.140	0.105	0.027	0.020
6	47.50	9.4	4.4	4.6	0.565	0.854	0.155	0.122	0.030	0.023
7	50.00	9.5	4.4	5.1	0.577	0.851	0.160	0.128	0.031	0.025
8	52.50	9.7	4.4	5.5	0.577	0.866	0.145	0.116	0.028	0.022
9	70.00	10.5	4.3	11.2	0.577	0.893	0.126	0.118	0.023	0.022
10	90.00	11.0	3.9	12.0	0.582	0.951	0.073	0.073	0.013	0.013
11	95.00	10.5	3.3	6.8	0.574	0.975	0.043	0.043	0.008	0.008

TABLE VII. - Continued. BLADE-ELEMENT DATA AT BLADE EDGES

FOR ROTOR 8

(1) 80 Percent of design speed; reading 81

RP	RADII		ABS BETAM		REL BETAM		TOTAL TEMP		TOTAL PRESS	
	IN	OUT	IN	OUT	IN	OUT	IN	RATIO	IN	RATIO
1	24.567	24.193	0.0	54.3	70.7	55.8	289.8	1.176	10.06	1.524
2	24.021	23.685	0.0	50.1	69.1	53.6	288.9	1.168	10.13	1.515
3	21.753	21.653	0.0	47.7	66.0	50.8	287.9	1.141	10.14	1.470
4	20.287	20.383	0.0	49.7	64.4	46.6	287.9	1.137	10.14	1.461
5	19.990	20.129	0.0	50.4	64.1	46.1	287.6	1.136	10.14	1.454
6	19.690	19.875	0.0	51.4	63.8	46.0	287.9	1.135	10.14	1.445
7	19.388	19.621	0.0	52.4	63.5	45.4	287.7	1.134	10.14	1.439
8	19.086	19.367	0.0	52.8	63.2	44.0	288.1	1.134	10.14	1.440
9	16.891	17.589	0.0	50.4	60.8	35.4	287.7	1.123	10.14	1.440
10	14.176	15.557	0.0	52.7	58.1	17.2	287.7	1.122	10.14	1.471
11	13.447	15.049	0.0	54.3	56.7	7.6	287.7	1.130	10.14	1.511

RP	ABS VEL		REL VEL		MERID VEL		TANG VEL		WHEEL SPEED	
	IN	OUT	IN	OUT	IN	OUT	IN	OUT	IN	OUT
1	115.7	194.8	349.8	201.8	115.7	113.6	0.0	158.3	330.1	325.1
2	123.0	193.9	344.9	210.0	123.0	124.5	0.0	148.7	322.3	317.8
3	129.8	185.8	319.6	197.9	129.8	125.1	0.0	137.4	292.1	290.8
4	130.2	189.1	301.8	178.1	130.2	122.4	0.0	144.1	272.2	273.5
5	130.1	188.5	298.1	173.2	130.1	120.1	0.0	145.3	268.3	270.1
6	130.0	187.3	294.9	168.2	130.0	116.9	0.0	146.3	264.7	267.2
7	130.0	186.7	290.9	162.1	130.0	113.8	0.0	148.0	260.3	263.4
8	129.9	188.7	287.6	158.5	129.9	114.1	0.0	150.3	256.6	260.4
9	126.5	193.0	259.6	150.8	126.5	123.0	0.0	148.7	226.7	236.1
10	118.5	212.6	224.2	134.8	118.5	128.8	0.0	169.1	190.4	208.9
11	118.7	227.3	216.2	133.7	118.7	132.6	0.0	184.6	180.7	202.2

RP	ABS MACH NO		REL MACH NO		MERID MACH NO		MERID PEAK SS	
	IN	OUT	IN	OUT	IN	OUT	VEL R	MACH NO
1	0.343	0.542	1.037	0.561	0.343	0.316	0.982	1.492
2	0.366	0.542	1.026	0.587	0.366	0.348	1.012	1.474
3	0.387	0.525	0.954	0.559	0.387	0.354	0.964	1.466
4	0.389	0.536	0.901	0.505	0.389	0.347	0.940	1.424
5	0.388	0.535	0.890	0.492	0.388	0.341	0.923	1.415
6	0.388	0.531	0.880	0.477	0.388	0.332	0.899	1.406
7	0.388	0.530	0.869	0.460	0.388	0.323	0.875	1.391
8	0.387	0.536	0.858	0.450	0.387	0.324	0.878	1.380
9	0.377	0.552	0.774	0.431	0.377	0.352	0.972	1.273
10	0.353	0.612	0.668	0.388	0.353	0.371	1.087	1.085
11	0.354	0.655	0.644	0.386	0.354	0.382	1.117	1.018

RP	PERCENT SPAN	INCIDENCE		DEV	D-FACT	EFF	LOSS COEFF		LOSS PARAM	
		MEAN	SS				TOT	PROF	TOT	PROF
1	5.00	8.9	6.2	3.8	0.571	0.727	0.270	0.240	0.050	0.045
2	10.00	8.6	5.6	2.4	0.530	0.749	0.244	0.218	0.047	0.042
3	30.00	10.1	6.0	4.5	0.507	0.824	0.166	0.148	0.031	0.028
4	42.50	11.0	6.2	4.8	0.542	0.836	0.166	0.156	0.032	0.030
5	45.00	11.2	6.3	5.4	0.552	0.831	0.172	0.164	0.033	0.031
6	47.50	11.3	6.3	6.4	0.564	0.821	0.185	0.177	0.034	0.033
7	50.00	11.4	6.3	7.0	0.579	0.817	0.191	0.185	0.036	0.034
8	52.50	11.6	6.3	6.9	0.586	0.817	0.196	0.191	0.037	0.036
9	70.00	12.4	6.2	9.3	0.554	0.889	0.131	0.131	0.025	0.025
10	90.00	12.9	5.8	10.7	0.552	0.956	0.066	0.066	0.012	0.012
11	95.00	12.3	5.1	7.9	0.547	0.966	0.058	0.058	0.010	0.010

TABLE VII. - Continued. BLADE-ELEMENT DATA AT BLADE EDGES

FOR ROTOR 8

(m) 70 Percent of design speed; reading 74

RP	RADII		ABS BETAM		REL BETAM		TOTAL TEMP		TOTAL PRESS	
	IN	OUT	IN	OUT	IN	OUT	IN	RATIO	IN	RATIO
1	24.567	24.193	0.0	24.1	64.3	54.8	288.7	1.073	10.05	1.227
2	24.021	23.685	0.0	23.7	62.5	53.7	288.4	1.069	10.12	1.223
3	21.753	21.653	0.0	24.3	59.1	49.4	288.1	1.066	10.14	1.228
4	20.287	20.383	0.0	27.5	57.2	45.4	288.1	1.067	10.14	1.230
5	19.990	20.129	0.0	28.9	56.9	44.1	288.1	1.069	10.14	1.234
6	19.690	19.875	0.0	30.4	56.5	43.0	288.0	1.073	10.14	1.232
7	19.388	19.621	0.0	31.7	56.1	41.8	288.1	1.074	10.15	1.233
8	19.086	19.367	0.0	31.7	55.8	40.6	288.0	1.072	10.14	1.239
9	16.891	17.589	0.0	33.3	53.2	33.0	288.0	1.073	10.14	1.261
10	14.176	15.557	0.0	41.0	50.2	15.5	287.9	1.083	10.14	1.308
11	13.447	15.049	0.0	44.4	48.8	8.9	287.9	1.090	10.14	1.329

RP	ABS VEL		REL VEL		MERID VEL		TANG VEL		WHEEL SPEED	
	IN	OUT	IN	OUT	IN	OUT	IN	OUT	IN	OUT
1	138.8	166.4	319.7	263.9	138.8	151.9	0.0	67.8	287.9	283.6
2	146.5	168.4	317.2	260.4	146.5	154.2	0.0	67.6	281.3	277.4
3	152.2	171.9	296.7	240.6	152.2	156.6	0.0	70.9	254.7	253.5
4	153.2	175.2	282.5	221.4	153.2	155.4	0.0	80.9	237.4	238.6
5	152.9	177.2	279.9	216.0	152.9	155.1	0.0	85.7	234.4	236.0
6	152.8	177.8	276.7	209.6	152.8	153.4	0.0	89.9	230.6	232.8
7	152.5	179.1	273.8	204.3	152.5	152.4	0.0	94.0	227.4	230.1
8	152.2	181.1	270.5	202.9	152.2	154.1	0.0	95.0	223.7	227.0
9	147.9	188.8	247.2	188.1	147.9	157.7	0.0	103.8	198.1	206.3
10	138.6	211.1	216.5	165.4	138.6	159.4	0.0	138.4	166.4	182.6
11	137.7	217.3	209.3	157.1	137.7	155.2	0.0	152.0	157.6	176.3

RP	ABS MACH NO		REL MACH NO		MERID MACH NO		MERID PEAK SS	
	IN	OUT	IN	OUT	IN	OUT	VEL R	MACH NO
1	0.415	0.483	0.955	0.765	0.415	0.441	1.094	1.196
2	0.439	0.490	0.949	0.757	0.439	0.448	1.053	1.167
3	0.456	0.501	0.890	0.702	0.456	0.457	1.029	1.155
4	0.460	0.511	0.848	0.646	0.460	0.454	1.015	1.129
5	0.459	0.517	0.840	0.630	0.459	0.453	1.014	1.126
6	0.459	0.518	0.830	0.611	0.459	0.447	1.004	1.117
7	0.458	0.522	0.821	0.595	0.458	0.444	0.999	1.110
8	0.457	0.528	0.812	0.592	0.457	0.450	1.012	1.100
9	0.443	0.552	0.741	0.550	0.443	0.461	1.066	1.027
10	0.414	0.619	0.648	0.485	0.414	0.467	1.151	0.878
11	0.412	0.636	0.626	0.460	0.412	0.454	1.127	0.821

RP	PERCENT SPAN		INCIDENCE MEAN SS		DEV	D-FACT	EFF	LOSS COEFF		LOSS PARAM	
	SPAN	MEAN	SS	TOT				PROF	TOT	PROF	
1	5.00	2.4	-0.3	2.9	0.244	0.830	0.088	0.087	0.017	0.017	
2	10.00	2.0	-1.0	2.5	0.247	0.854	0.074	0.073	0.014	0.014	
3	30.00	3.2	-0.9	3.1	0.259	0.921	0.042	0.042	0.008	0.008	
4	42.50	3.7	-1.0	3.6	0.296	0.906	0.055	0.055	0.011	0.011	
5	45.00	3.9	-1.0	3.4	0.312	0.898	0.062	0.062	0.012	0.012	
6	47.50	4.0	-1.0	3.4	0.330	0.847	0.099	0.099	0.020	0.020	
7	50.00	4.1	-1.0	3.4	0.345	0.833	0.112	0.112	0.022	0.022	
8	52.50	4.2	-1.1	3.5	0.343	0.877	0.082	0.082	0.016	0.016	
9	70.00	4.8	-1.4	7.0	0.338	0.940	0.048	0.048	0.009	0.009	
10	90.00	5.0	-2.0	9.0	0.366	0.958	0.048	0.048	0.009	0.009	
11	95.00	4.5	-2.7	9.2	0.390	0.940	0.078	0.078	0.014	0.014	

TABLE VII. - Continued. BLADE-ELEMENT DATA AT BLADE EDGES

FOR ROTOR 8

(n) 70 Percent of design speed; reading 75

RP	RADII		ABS BETAM		REL BETAM		TOTAL TEMP		TOTAL PRESS	
	IN	OUT	IN	OUT	IN	OUT	IN	RATIO	IN	RATIO
1	24.567	24.193	0.0	28.5	64.9	54.7	288.6	1.082	10.05	1.259
2	24.021	23.685	0.0	27.8	63.2	53.9	288.4	1.076	10.12	1.253
3	21.753	21.653	0.0	28.2	60.0	49.6	288.1	1.072	10.14	1.253
4	20.287	20.383	0.0	30.8	58.1	45.5	288.1	1.073	10.14	1.254
5	19.990	20.129	0.0	31.8	57.7	44.2	288.1	1.074	10.14	1.258
6	19.690	19.875	0.0	33.0	57.4	43.4	288.2	1.077	10.14	1.256
7	19.388	19.621	0.0	34.4	57.1	42.2	288.0	1.078	10.14	1.255
8	19.086	19.367	0.0	34.1	56.7	40.9	288.0	1.077	10.15	1.260
9	16.891	17.589	0.0	35.9	54.3	33.3	288.0	1.077	10.14	1.276
10	14.176	15.557	0.0	43.0	51.5	15.7	287.9	1.085	10.14	1.316
11	13.447	15.049	0.0	46.3	50.1	8.2	288.0	1.092	10.14	1.342

RP	ABS VEL		REL VEL		MERID VEL		TANG VEL		WHEEL SPEED	
	IN	OUT	IN	OUT	IN	OUT	IN	OUT	IN	OUT
1	134.9	165.0	318.2	251.2	134.9	145.0	0.0	78.7	288.2	283.8
2	142.3	165.8	316.1	248.7	142.3	146.6	0.0	77.4	282.3	278.3
3	147.9	168.8	295.5	229.7	147.9	148.8	0.0	79.6	255.8	254.7
4	148.0	172.3	280.2	211.4	148.0	148.1	0.0	88.2	237.9	239.1
5	148.0	174.5	277.2	206.8	148.0	148.3	0.0	92.0	234.5	236.1
6	147.7	174.7	274.6	201.5	147.7	146.4	0.0	95.3	231.4	235.6
7	147.7	175.8	271.5	195.8	147.7	145.1	0.0	99.2	227.9	230.6
8	146.9	177.6	267.6	194.5	146.9	147.0	0.0	99.7	223.7	227.0
9	142.4	184.8	244.1	179.1	142.4	149.8	0.0	108.2	198.3	206.5
10	132.3	205.6	212.3	156.2	132.3	150.4	0.0	140.1	166.1	182.3
11	131.7	214.3	205.3	149.5	131.7	148.0	0.0	155.1	157.6	176.4

RP	ABS MACH NO		REL MACH NO		MERID MACH NO		MERID PEAK SS	
	IN	OUT	IN	OUT	IN	OUT	VEL R	MACH NO
1	0.402	0.476	0.949	0.725	0.402	0.419	1.076	1.214
2	0.425	0.480	0.945	0.720	0.425	0.425	1.030	1.190
3	0.443	0.490	0.885	0.668	0.443	0.432	1.006	1.175
4	0.444	0.501	0.840	0.615	0.444	0.431	1.000	1.146
5	0.443	0.508	0.831	0.601	0.443	0.431	1.002	1.139
6	0.443	0.507	0.822	0.585	0.443	0.425	0.991	1.135
7	0.442	0.510	0.814	0.568	0.442	0.421	0.983	1.126
8	0.440	0.516	0.802	0.565	0.440	0.427	1.000	1.114
9	0.426	0.538	0.730	0.522	0.426	0.436	1.052	1.039
10	0.395	0.601	0.634	0.456	0.395	0.440	1.137	0.887
11	0.393	0.626	0.613	0.437	0.393	0.432	1.124	0.832

RP	PERCENT SPAN	INCIDENCE		DEV	D-FACT	EFF	LOSS COEFF		LOSS PARAM	
		MEAN	SS				TOT	PROF	TOT	PROF
1	5.00	3.1	0.4	2.8	0.291	0.824	0.103	0.102	0.020	0.019
2	10.00	2.7	-0.3	2.7	0.292	0.873	0.070	0.070	0.013	0.013
3	30.00	4.0	-0.0	3.3	0.302	0.922	0.046	0.046	0.009	0.009
4	42.50	4.7	-0.1	3.8	0.333	0.917	0.053	0.053	0.010	0.010
5	45.00	4.8	-0.1	3.5	0.345	0.921	0.052	0.052	0.010	0.010
6	47.50	4.9	-0.1	3.8	0.360	0.878	0.084	0.084	0.016	0.016
7	50.00	5.0	-0.1	3.8	0.376	0.857	0.102	0.102	0.020	0.020
8	52.50	5.1	-0.2	3.8	0.371	0.890	0.079	0.079	0.016	0.016
9	70.00	5.9	-0.3	7.2	0.371	0.937	0.053	0.053	0.010	0.010
10	90.00	6.3	-0.8	9.2	0.398	0.960	0.048	0.048	0.009	0.009
11	95.00	5.7	-1.5	8.5	0.418	0.954	0.063	0.063	0.011	0.011

TABLE VII. - Continued. BLADE-ELEMENT DATA AT BLADE EDGES

FOR ROTOR 8

(o) 70 Percent of design speed; reading 76

RP	RADII		ABS BETAM		REL BETAM		TOTAL TEMP		TOTAL PRESS	
	IN	OUT	IN	OUT	IN	OUT	IN	RATIO	IN	RATIO
1	24.567	24.193	0.0	34.8	66.2	54.6	288.6	1.097	10.06	1.305
2	24.021	23.685	0.0	33.4	64.6	53.7	288.4	1.091	10.13	1.296
3	21.753	21.653	0.0	33.2	61.5	50.0	288.1	1.082	10.14	1.286
4	20.287	20.383	0.0	35.3	59.7	46.0	288.1	1.082	10.14	1.286
5	19.990	20.129	0.0	35.9	59.4	44.7	288.1	1.082	10.14	1.289
6	19.690	19.875	0.0	37.2	59.1	43.9	288.1	1.084	10.14	1.285
7	19.388	19.621	0.0	38.5	58.7	42.9	288.1	1.085	10.14	1.283
8	19.086	19.367	0.0	38.5	58.4	41.9	288.0	1.082	10.14	1.284
9	16.891	17.589	0.0	39.5	56.2	33.4	288.0	1.082	10.14	1.299
10	14.176	15.557	0.0	44.9	53.3	16.8	288.0	1.089	10.14	1.328
11	13.447	15.049	0.0	49.0	51.9	7.3	287.9	1.096	10.14	1.358

RP	ABS VEL		REL VEL		MERID VEL		TANG VEL		WHEEL SPEED	
	IN	OUT	IN	OUT	IN	OUT	IN	OUT	IN	OUT
1	127.4	164.6	315.3	233.1	127.4	135.1	0.0	94.0	288.4	284.0
2	133.9	164.9	311.9	232.2	133.9	137.6	0.0	90.8	281.8	277.8
3	138.5	164.5	290.1	213.8	138.5	137.6	0.0	90.1	255.0	253.8
4	138.9	168.3	275.7	197.7	138.9	137.4	0.0	97.2	238.2	239.3
5	138.5	170.0	272.3	193.8	138.5	137.7	0.0	99.7	234.4	236.1
6	138.3	170.0	269.1	188.0	138.3	135.4	0.0	102.7	230.9	233.0
7	138.1	170.6	266.0	182.1	138.1	133.4	0.0	106.2	227.4	230.1
8	137.6	171.2	262.4	179.8	137.6	133.9	0.0	106.7	223.4	226.7
9	132.8	180.1	238.5	166.5	132.8	138.9	0.0	114.5	198.1	236.3
10	123.8	198.4	207.3	146.9	123.8	140.6	0.0	140.0	166.2	182.4
11	123.5	210.0	200.0	138.8	123.5	137.7	0.0	158.6	157.4	176.1

RP	ABS MACH NO		REL MACH NO		MERID MACH NO		MERID PEAK SS VEL R MACH NO	
	IN	OUT	IN	OUT	IN	OUT		
1	0.379	0.472	0.939	0.668	0.379	0.387	1.061	1.243
2	0.399	0.474	0.931	0.668	0.399	0.396	1.028	1.218
3	0.414	0.475	0.867	0.618	0.414	0.397	0.994	1.198
4	0.415	0.487	0.824	0.572	0.415	0.397	0.989	1.172
5	0.414	0.492	0.814	0.561	0.414	0.398	0.994	1.164
6	0.414	0.491	0.804	0.543	0.414	0.392	0.979	1.155
7	0.413	0.493	0.795	0.526	0.413	0.386	0.966	1.146
8	0.411	0.495	0.784	0.520	0.411	0.387	0.973	1.135
9	0.397	0.522	0.712	0.483	0.397	0.403	1.046	1.058
10	0.369	0.577	0.618	0.427	0.369	0.409	1.135	0.904
11	0.368	0.612	0.596	0.404	0.368	0.401	1.115	0.846

RP	PERCENT SPAN		INCIDENCE		DEV	D-FACT	EFF	LOSS COEFF		LOSS PARAM	
	SPAN	MEAN	MEAN	SS				TOT	PROF	TOT	PROF
1	5.00	4.4	1.6	2.6	0.358	0.812	0.130	0.128	0.025	0.025	
2	10.00	4.1	1.1	2.5	0.349	0.848	0.100	0.099	0.019	0.019	
3	30.00	5.6	1.5	3.7	0.354	0.910	0.061	0.061	0.012	0.011	
4	42.50	6.3	1.5	4.2	0.381	0.912	0.064	0.064	0.012	0.012	
5	45.00	6.5	1.6	4.0	0.388	0.916	0.063	0.063	0.012	0.012	
6	47.50	6.6	1.6	4.3	0.405	0.887	0.087	0.087	0.017	0.017	
7	50.00	6.7	1.5	4.5	0.422	0.872	0.102	0.102	0.020	0.020	
8	52.50	6.8	1.5	4.8	0.421	0.898	0.081	0.081	0.016	0.016	
9	70.00	7.7	1.5	7.4	0.415	0.941	0.056	0.056	0.011	0.011	
10	90.00	8.1	1.1	10.3	0.429	0.951	0.064	0.064	0.012	0.012	
11	95.00	7.5	0.3	7.6	0.460	0.957	0.064	0.064	0.012	0.012	

TABLE VII. - Continued. BLADE-ELEMENT DATA AT BLADE EDGES

FOR ROTOR 8.

(p) 70 Percent of design speed; reading 77

RP	RADII		ABS BETAM		REL BETAM		TOTAL TEMP		TOTAL PRESS	
	IN	OUT	IN	OUT	IN	OUT	IN	RATIO	IN	RATIO
1	24.567	24.193	0.0	42.3	68.4	55.0	288.6	1.115	10.07	1.341
2	24.021	23.685	0.0	40.9	66.9	53.6	288.5	1.106	10.12	1.337
3	21.753	21.653	0.0	40.2	63.9	50.1	288.1	1.094	10.14	1.321
4	20.287	20.383	0.0	41.3	62.3	45.5	288.0	1.094	10.14	1.323
5	19.990	20.129	0.0	41.8	61.9	45.0	288.1	1.094	10.14	1.319
6	19.690	19.875	0.0	44.5	61.7	44.5	288.0	1.093	10.14	1.308
7	19.388	19.621	0.0	44.5	61.3	43.7	288.1	1.092	10.14	1.310
8	19.086	19.367	0.0	44.6	61.0	43.0	288.0	1.092	10.14	1.308
9	16.891	17.589	0.0	44.7	58.7	35.4	288.0	1.090	10.14	1.322
10	14.176	15.557	0.0	49.7	56.0	16.4	287.9	1.091	10.14	1.337
11	13.447	15.049	0.0	51.8	54.6	7.3	287.9	1.098	10.13	1.371

RP	ABS VEL		REL VEL		MERID VEL		TANG VEL		WHEEL SPEED	
	IN	OUT	IN	OUT	IN	OUT	IN	OUT	IN	OUT
1	114.2	163.8	309.6	211.4	114.2	121.2	0.0	110.2	287.8	283.4
2	120.1	164.9	305.6	210.2	120.1	124.7	0.0	107.9	281.0	277.1
3	125.2	162.8	284.2	193.9	125.2	124.3	0.0	105.1	255.1	253.9
4	125.0	167.7	268.8	179.9	125.0	126.0	0.0	110.7	237.9	239.1
5	125.0	167.3	265.7	176.2	125.0	124.6	0.0	111.6	234.5	236.1
6	124.5	166.2	262.2	166.1	124.5	118.5	0.0	116.5	230.8	232.9
7	124.5	166.5	259.3	164.2	124.5	118.7	0.0	116.8	227.5	230.3
8	124.2	166.4	256.1	162.1	124.2	118.6	0.0	116.8	224.0	227.3
9	120.7	176.5	232.4	150.2	120.7	125.4	0.0	124.2	198.6	206.8
10	112.4	191.6	200.9	129.2	112.4	123.9	0.0	146.2	166.5	182.7
11	112.4	204.4	194.0	127.5	112.4	126.4	0.0	160.6	158.1	176.9

RP	ABS MACH NO		REL MACH NO		MERID MACH NO		MERID PEAK SS	
	IN	OUT	IN	OUT	IN	OUT	VEL R	MACH NO
1	0.339	0.465	0.920	0.601	0.339	0.344	1.061	1.288
2	0.357	0.471	0.909	0.600	0.357	0.356	1.038	1.263
3	0.373	0.467	0.847	0.556	0.373	0.357	0.993	1.239
4	0.373	0.482	0.801	0.517	0.373	0.362	1.008	1.208
5	0.372	0.481	0.792	0.507	0.372	0.358	0.997	1.200
6	0.371	0.478	0.781	0.478	0.371	0.341	0.952	1.191
7	0.371	0.479	0.773	0.472	0.371	0.341	0.953	1.182
8	0.370	0.479	0.763	0.466	0.370	0.341	0.955	1.172
9	0.359	0.510	0.692	0.434	0.359	0.362	1.039	1.088
10	0.334	0.556	0.597	0.375	0.334	0.359	1.102	0.928
11	0.334	0.593	0.577	0.370	0.334	0.367	1.125	0.871

RP	PERCENT		INCIDENCE		DEV	D-FACT	EFF	LOSS COEFF		LOSS PARAM	
	SPAN	MEAN	SS	SS				TOT	PROF	TOT	PROF
1	5.00	6.6	3.8	3.0	0.434	0.761	0.196	0.193	0.037	0.037	
2	10.00	6.3	3.4	2.4	0.425	0.815	0.145	0.143	0.028	0.028	
3	30.00	7.9	3.9	3.8	0.427	0.877	0.098	0.097	0.018	0.018	
4	42.50	8.8	4.1	3.7	0.445	0.885	0.099	0.099	0.019	0.019	
5	45.00	9.0	4.1	4.3	0.452	0.878	0.107	0.107	0.021	0.021	
6	47.50	9.2	4.1	4.9	0.486	0.862	0.122	0.122	0.023	0.023	
7	50.00	9.3	4.1	5.4	0.487	0.869	0.118	0.118	0.023	0.023	
8	52.50	9.4	4.1	5.9	0.487	0.870	0.119	0.119	0.023	0.023	
9	70.00	10.2	4.1	7.3	0.480	0.920	0.085	0.085	0.017	0.017	
10	90.00	10.8	3.7	9.9	0.505	0.948	0.074	0.074	0.014	0.014	
11	95.00	10.2	3.0	7.7	0.503	0.961	0.062	0.062	0.011	0.011	

TABLE VII. - Continued. BLADE-ELEMENT DATA AT BLADE EDGES

FOR ROTOR 8

(q) 70 Percent of design speed; reading 78

RP	RADII		ABS BETAM		REL BETAM		TOTAL TEMP		TOTAL PRESS	
	IN	OUT	IN	OUT	IN	OUT	IN	RATIO	IN	RATIO
1	24.567	24.193	0.0	55.4	71.0	56.7	288.7	1.138	10.08	1.365
2	24.021	23.685	0.0	52.0	69.5	55.2	288.4	1.128	10.13	1.352
3	21.753	21.653	0.0	46.8	66.7	50.7	288.2	1.104	10.14	1.337
4	20.287	20.383	0.0	46.6	65.0	46.2	288.1	1.101	10.14	1.338
5	19.990	20.129	0.0	46.8	64.7	46.1	288.0	1.100	10.14	1.331
6	19.690	19.875	0.0	47.6	64.4	45.8	288.2	1.099	10.14	1.324
7	19.388	19.621	0.0	49.0	64.0	45.0	288.1	1.099	10.14	1.320
8	19.086	19.367	0.0	49.4	63.7	43.5	287.9	1.099	10.14	1.322
9	16.891	17.589	0.0	49.5	61.4	32.9	288.0	1.095	10.14	1.334
10	14.176	15.557	0.0	51.4	58.4	16.5	287.9	1.093	10.14	1.348
11	13.447	15.049	0.0	53.3	56.9	7.3	288.0	1.099	10.14	1.377

RP	ABS VEL		REL VEL		MERID VEL		TANG VEL		WHEEL SPEED	
	IN	OUT	IN	OUT	IN	OUT	IN	OUT	IN	OUT
1	99.0	168.3	304.9	174.1	99.0	95.6	0.0	138.5	288.4	284.0
2	105.4	165.8	300.7	179.1	105.4	102.2	0.0	130.5	281.6	277.7
3	110.1	162.1	277.8	175.5	110.1	111.1	0.0	118.1	255.1	253.9
4	111.0	165.9	263.0	164.8	111.0	114.0	0.0	120.5	238.4	239.6
5	110.8	164.1	259.5	161.9	110.8	112.3	0.0	119.7	234.7	236.3
6	111.0	163.2	256.5	157.7	111.0	110.1	0.0	120.4	231.3	233.4
7	111.0	163.4	253.3	151.6	111.0	107.2	0.0	123.3	227.7	230.5
8	110.7	165.3	250.1	148.2	110.7	107.5	0.0	125.6	224.3	227.6
9	108.2	175.0	226.0	135.4	108.2	113.6	0.0	133.1	198.5	206.7
10	102.2	188.6	195.0	122.8	102.2	117.7	0.0	147.3	166.1	182.2
11	102.8	200.8	188.1	121.1	102.8	120.1	0.0	161.0	157.5	176.3

RP	ABS MACH NO		REL MACH NO		MERID MACH NO		MERID PEAK SS	
	IN	OUT	IN	OUT	IN	OUT	VEL R	MACH NO
1	0.293	0.474	0.903	0.490	0.293	0.269	0.966	1.349
2	0.313	0.468	0.892	0.506	0.313	0.289	0.969	1.320
3	0.327	0.463	0.825	0.501	0.327	0.317	1.009	1.286
4	0.330	0.475	0.781	0.472	0.330	0.326	1.027	1.251
5	0.329	0.470	0.771	0.464	0.329	0.322	1.013	1.241
6	0.330	0.467	0.762	0.452	0.330	0.315	0.991	1.231
7	0.330	0.468	0.753	0.434	0.330	0.307	0.966	1.220
8	0.329	0.474	0.743	0.425	0.329	0.308	0.971	1.210
9	0.321	0.504	0.671	0.390	0.321	0.327	1.050	1.117
10	0.303	0.546	0.578	0.355	0.303	0.341	1.152	0.946
11	0.305	0.582	0.558	0.351	0.305	0.348	1.169	0.886

RP	PERCENT		INCIDENCE		DEV	D-FACT	EFF	LOSS COEFF		LOSS PARAM	
	SPAN	MEAN	SS	SS				TOT	PROF	TOT	PROF
1	5.00	9.3	6.5	4.7	0.578	0.675	0.315	0.310	0.057	0.056	
2	10.00	9.0	6.0	4.0	0.544	0.705	0.274	0.271	0.051	0.050	
3	30.00	10.7	6.7	4.4	0.494	0.829	0.154	0.153	0.029	0.029	
4	42.50	11.6	6.8	4.5	0.500	0.857	0.137	0.137	0.026	0.026	
5	45.00	11.7	6.9	5.4	0.502	0.847	0.148	0.148	0.028	0.028	
6	47.50	11.9	6.8	6.2	0.512	0.839	0.157	0.157	0.029	0.029	
7	50.00	12.0	6.8	6.6	0.531	0.834	0.165	0.165	0.031	0.031	
8	52.50	12.1	6.9	6.4	0.539	0.840	0.162	0.162	0.031	0.031	
9	70.00	12.9	6.7	6.9	0.540	0.901	0.116	0.116	0.023	0.023	
10	90.00	13.2	6.1	10.0	0.524	0.957	0.064	0.064	0.012	0.012	
11	95.00	12.5	5.3	7.6	0.522	0.970	0.052	0.052	0.009	0.009	

TABLE VII. - Continued. BLADE-ELEMENT DATA AT BLADE EDGES

FOR ROTOR 8

(r) 60 Percent of design speed; reading 82

RP	RADII		ABS BETAM		REL BETAM		TOTAL TEMP		TOTAL PRESS	
	IN	OUT	IN	OUT	IN	OUT	IN	RATIO	IN	RATIO
1	24.567	24.193	0.0	57.6	71.9	56.9	288.6	1.104	10.10	1.264
2	24.021	23.685	0.0	51.9	70.4	55.4	288.3	1.095	10.13	1.251
3	21.753	21.653	0.0	44.6	67.7	50.6	288.2	1.077	10.14	1.241
4	20.287	20.383	0.0	46.7	66.0	46.6	288.1	1.073	10.14	1.236
5	19.990	20.129	0.0	47.7	65.7	46.5	288.2	1.073	10.14	1.232
6	19.690	19.875	0.0	48.6	65.4	46.3	288.2	1.073	10.14	1.228
7	19.388	19.621	0.0	50.0	65.1	45.6	288.0	1.072	10.14	1.224
8	19.086	19.367	0.0	50.6	64.8	44.6	287.8	1.071	10.14	1.224
9	16.891	17.589	0.0	48.7	62.5	34.5	288.1	1.069	10.14	1.231
10	14.176	15.557	0.0	50.5	59.6	16.6	288.1	1.068	10.13	1.249
11	13.447	15.049	0.0	52.8	58.0	7.9	288.1	1.072	10.13	1.265

RP	ABS VEL		REL VEL		MERID VEL		TANG VEL		WHEEL SPEED	
	IN	OUT	IN	OUT	IN	OUT	IN	OUT	IN	OUT
1	80.5	145.9	259.9	143.4	80.5	78.2	0.0	123.1	247.1	243.3
2	85.8	141.5	255.9	153.7	85.8	87.3	0.0	111.3	241.1	237.8
3	89.8	138.7	236.3	155.6	89.8	98.8	0.0	97.4	218.6	217.6
4	90.4	140.7	222.7	140.4	90.4	96.5	0.0	102.5	203.5	204.5
5	90.5	139.4	220.0	136.4	90.5	93.9	0.0	103.1	200.6	202.0
6	90.5	138.7	217.8	132.8	90.5	91.7	0.0	104.0	198.1	199.9
7	90.3	138.3	214.3	127.1	90.3	88.9	0.0	105.9	194.4	196.7
8	90.1	139.1	211.8	124.1	90.1	88.4	0.0	107.4	191.7	194.6
9	88.2	146.6	191.2	117.3	88.2	96.7	0.0	110.2	169.6	176.6
10	83.2	161.9	164.5	107.5	83.2	103.0	0.0	125.0	141.9	155.7
11	84.4	171.5	159.2	104.6	84.4	103.6	0.0	136.7	135.0	151.1

RP	ABS MACH NO		REL MACH NO		MERID MACH NO		MERID PEAK SS	
	IN	OUT	IN	OUT	IN	OUT	VEL R	MACH NO
1	0.238	0.415	0.767	0.408	0.238	0.222	0.971	1.170
2	0.254	0.404	0.757	0.439	0.254	0.249	1.018	1.144
3	0.266	0.399	0.699	0.448	0.266	0.284	1.100	1.114
4	0.268	0.406	0.659	0.405	0.268	0.278	1.067	1.078
5	0.268	0.402	0.651	0.393	0.268	0.271	1.038	1.070
6	0.268	0.400	0.644	0.383	0.268	0.264	1.014	1.065
7	0.267	0.399	0.635	0.366	0.267	0.256	0.985	1.051
8	0.267	0.402	0.627	0.358	0.267	0.255	0.981	1.045
9	0.261	0.424	0.566	0.339	0.261	0.280	1.096	0.963
10	0.246	0.471	0.486	0.312	0.246	0.299	1.237	0.815
11	0.250	0.499	0.471	0.304	0.250	0.301	1.227	0.765

RP	PERCENT		INCIDENCE		DEV	D-FACT	EFF	LOSS COEFF		LOSS PARAM	
	SPAN	MEAN	SS	TOT				PROF	TOT	PROF	
1	5.00	10.2	7.4	5.0	0.603	0.664	0.328	0.328	0.059	0.059	
2	10.00	9.9	6.9	4.2	0.539	0.697	0.279	0.279	0.051	0.051	
3	30.00	11.7	7.7	4.3	0.463	0.829	0.151	0.151	0.028	0.028	
4	42.50	12.6	7.8	4.8	0.497	0.852	0.139	0.139	0.026	0.026	
5	45.00	12.7	7.9	5.8	0.508	0.841	0.151	0.151	0.028	0.028	
6	47.50	12.9	7.9	6.7	0.519	0.830	0.164	0.164	0.030	0.030	
7	50.00	13.0	7.9	7.2	0.539	0.823	0.174	0.174	0.032	0.032	
8	52.50	13.2	8.0	7.5	0.547	0.832	0.167	0.167	0.031	0.031	
9	70.00	14.1	7.9	8.4	0.523	0.889	0.129	0.129	0.025	0.025	
10	90.00	14.4	7.4	10.1	0.501	0.960	0.061	0.061	0.011	0.011	
11	95.00	13.6	6.4	8.3	0.509	0.962	0.065	0.065	0.012	0.012	

TABLE VII. - Concluded. BLADE-ELEMENT DATA AT BLADE EDGES

FOR ROTOR 8

(s) 50 Percent of design speed; reading 83

RP	RADII		ABS BETAM		REL BETAM		TOTAL TEMP		TOTAL PRESS	
	IN	OUT	IN	OUT	IN	OUT	IN	RATIO	IN	RATIO
1	24.567	24.193	0.0	56.8	72.4	57.3	288.6	1.070	10.11	1.177
2	24.021	23.685	0.0	50.7	71.0	55.3	288.4	1.065	10.13	1.171
3	21.753	21.653	0.0	44.6	68.2	50.9	288.1	1.053	10.14	1.162
4	20.287	20.383	0.0	46.8	66.6	46.4	288.0	1.051	10.13	1.162
5	19.990	20.129	0.0	47.7	66.4	45.8	288.2	1.051	10.14	1.160
6	19.690	19.875	0.0	48.7	66.0	45.5	288.0	1.051	10.13	1.157
7	19.388	19.621	0.0	50.1	65.7	45.0	287.9	1.050	10.13	1.155
8	19.086	19.367	0.0	50.7	65.3	44.1	288.1	1.050	10.13	1.153
9	16.891	17.589	0.0	49.1	63.1	35.3	288.0	1.047	10.13	1.154
10	14.176	15.557	0.0	50.0	60.2	17.9	288.0	1.048	10.13	1.167
11	13.447	15.049	0.0	52.7	58.6	7.9	288.1	1.050	10.13	1.180

RP	ABS VEL		REL VEL		MERID VEL		TANG VEL		WHEEL SPEED	
	IN	OUT	IN	OUT	IN	OUT	IN	OUT	IN	OUT
1	65.5	120.3	216.5	121.8	65.5	65.8	0.0	100.7	206.3	203.2
2	69.6	118.0	213.8	131.3	69.6	74.7	0.0	91.3	202.2	199.3
3	73.1	115.0	196.6	130.0	73.1	81.9	0.0	80.8	182.5	181.7
4	73.6	118.1	185.4	117.2	73.6	80.8	0.0	86.1	170.1	171.0
5	73.4	118.1	183.1	113.9	73.4	79.4	0.0	87.3	167.7	168.9
6	73.5	117.0	180.6	110.3	73.5	77.3	0.0	87.8	165.0	166.5
7	73.3	116.8	178.3	105.9	73.3	74.9	0.0	89.6	162.5	164.5
8	73.4	117.0	175.8	103.1	73.4	74.1	0.0	90.5	159.8	162.2
9	71.9	120.9	158.7	97.1	71.9	79.3	0.0	91.4	141.5	147.4
10	68.1	134.0	136.9	90.5	68.1	86.1	0.0	102.6	118.8	130.3
11	69.0	143.7	132.4	87.8	69.0	87.0	0.0	114.3	113.0	126.4

RP	ABS MACH NO		REL MACH NO		MERID MACH NO		MERID PEAK SS	
	IN	OUT	IN	OUT	IN	OUT	VEL R	MACH NO
1	0.193	0.346	0.638	0.350	0.193	0.189	1.004	0.982
2	0.205	0.340	0.631	0.378	0.205	0.215	1.073	0.966
3	0.216	0.333	0.581	0.376	0.216	0.237	1.121	0.935
4	0.217	0.342	0.547	0.340	0.217	0.234	1.098	0.906
5	0.217	0.342	0.540	0.330	0.217	0.230	1.083	0.900
6	0.217	0.339	0.533	0.320	0.217	0.224	1.051	0.891
7	0.217	0.339	0.527	0.307	0.217	0.217	1.021	0.884
8	0.217	0.339	0.519	0.299	0.217	0.215	1.010	0.874
9	0.212	0.352	0.469	0.282	0.212	0.230	1.103	0.806
10	0.201	0.391	0.404	0.264	0.201	0.251	1.264	0.685
11	0.204	0.419	0.391	0.256	0.204	0.254	1.260	0.643

RP	PERCENT SPAN		INCIDENCE		DEV	D-FACT	EFF	LOSS COEFF		LOSS PARAM	
	SPAN	MEAN	SS	SS				TOT	PROF	TOT	PROF
1	5.00	10.6	7.9	5.3	0.590	0.678	0.298	0.298	0.053	0.053	
2	10.00	10.5	7.5	4.1	0.523	0.706	0.261	0.261	0.048	0.048	
3	30.00	12.2	8.2	4.6	0.460	0.830	0.145	0.145	0.027	0.027	
4	42.50	13.1	8.4	4.6	0.496	0.858	0.130	0.130	0.025	0.025	
5	45.00	13.4	8.5	5.0	0.509	0.849	0.142	0.142	0.027	0.027	
6	47.50	13.5	8.5	6.0	0.521	0.839	0.153	0.153	0.029	0.029	
7	50.00	13.7	8.5	6.7	0.540	0.834	0.160	0.160	0.030	0.030	
8	52.50	13.8	8.5	7.0	0.549	0.825	0.174	0.174	0.033	0.033	
9	70.00	14.6	8.4	9.2	0.525	0.887	0.128	0.128	0.024	0.024	
10	90.00	14.9	7.9	11.3	0.491	0.949	0.077	0.077	0.014	0.014	
11	95.00	14.2	7.0	8.3	0.504	0.965	0.060	0.060	0.011	0.011	

TABLE VIII. - BLADE-ELEMENT DATA AT BLADE EDGES FOR STATOR 8

(a) 100 Percent of design speed; reading 58

RP	RADII		ABS BETAM		REL BETAM		TOTAL TEMP		TOTAL PRESS	
	IN	OUT	IN	OUT	IN	OUT	IN	RATIO	IN	RATIO
1	23.945	23.947	35.8	5.1	35.8	5.1	352.3	0.991	17.22	0.906
2	23.505	23.538	34.5	1.1	34.5	1.1	347.3	0.997	17.21	0.938
3	21.742	21.902	33.6	1.5	33.6	1.5	343.3	0.998	17.43	0.909
4	20.635	20.884	38.5	-0.2	38.5	-0.2	342.2	0.993	16.73	0.931
5	20.414	20.681	39.1	-0.9	39.1	-0.9	341.6	0.993	16.45	0.938
6	20.193	20.480	39.5	-1.5	39.5	-1.5	339.9	0.995	16.13	0.953
7	19.972	20.279	39.7	-1.6	39.7	-1.6	338.6	0.998	16.03	0.963
8	19.751	20.079	38.4	-1.9	38.4	-1.9	337.6	0.999	16.20	0.955
9	18.219	18.715	37.6	-1.7	37.6	-1.7	335.2	1.000	16.49	0.933
10	16.520	17.252	38.3	4.2	38.3	4.2	338.2	1.012	17.39	0.878
11	16.111	16.904	44.4	6.8	44.4	6.8	343.1	1.006	18.02	0.786

RP	ABS VEL		REL VEL		MERID VEL		TANG VEL		WHEEL SPEED	
	IN	OUT	IN	OUT	IN	OUT	IN	OUT	IN	OUT
1	263.8	255.9	263.8	255.9	214.0	254.9	154.2	22.8	0.	0.
2	263.7	266.0	263.7	266.0	217.5	266.0	149.2	5.0	0.	0.
3	277.3	263.3	277.3	263.3	230.9	263.2	153.6	6.9	0.	0.
4	269.4	265.4	269.4	265.4	210.8	265.4	167.8	-1.1	0.	0.
5	263.9	264.4	263.9	264.4	204.8	264.3	166.4	-4.3	0.	0.
6	255.6	264.0	255.6	264.0	197.3	263.9	162.5	-6.8	0.	0.
7	253.1	267.9	253.1	267.9	194.8	267.7	161.6	-7.7	0.	0.
8	258.6	270.5	258.6	270.5	202.6	270.4	160.8	-8.8	0.	0.
9	272.1	297.4	272.1	297.4	215.6	297.3	166.0	-9.0	0.	0.
10	305.9	339.3	305.9	339.3	240.0	338.4	189.6	24.6	0.	0.
11	309.0	342.0	309.0	342.0	220.7	339.6	216.3	40.4	0.	0.

RP	ABS MACH NO		REL MACH NO		MERID MACH NO		MERID PEAK SS	
	IN	OUT	IN	OUT	IN	OUT	VEL R	MACH NO
1	0.738	0.717	0.738	0.717	0.599	0.715	1.191	0.897
2	0.744	0.753	0.744	0.753	0.614	0.753	1.223	0.885
3	0.792	0.748	0.792	0.748	0.660	0.748	1.140	0.919
4	0.768	0.758	0.768	0.758	0.601	0.758	1.259	1.018
5	0.751	0.756	0.751	0.756	0.583	0.756	1.291	1.007
6	0.727	0.756	0.727	0.756	0.561	0.756	1.338	0.980
7	0.721	0.769	0.721	0.769	0.555	0.768	1.374	0.972
8	0.740	0.778	0.740	0.778	0.579	0.778	1.335	0.960
9	0.786	0.869	0.786	0.869	0.623	0.869	1.379	0.998
10	0.894	1.003	0.894	1.003	0.701	1.000	1.410	1.140
11	0.897	1.007	0.897	1.007	0.641	1.000	1.538	1.331

RP	PERCENT		INCIDENCE		DEV	D-FACT	EFF	LOSS COEFF		LOSS PARAM	
	SPAN	MEAN	SS	TOT				PROF	TOT	PROF	
1	5.00	-1.0	-7.1	16.2	0.195	0.	0.311	0.311	0.103	0.103	
2	10.00	-0.8	-6.9	11.3	0.170	0.	0.200	0.200	0.065	0.065	
3	30.00	-0.3	-6.4	10.5	0.210	0.	0.268	0.268	0.081	0.081	
4	42.50	4.2	-1.9	8.5	0.194	0.	0.215	0.215	0.062	0.062	
5	45.00	4.7	-1.5	7.8	0.181	0.	0.197	0.197	0.056	0.056	
6	47.50	4.9	-1.2	7.2	0.152	0.	0.160	0.160	0.045	0.045	
7	50.00	4.9	-1.2	7.0	0.127	0.	0.126	0.126	0.035	0.035	
8	52.50	3.5	-2.6	6.8	0.133	0.	0.148	0.148	0.041	0.041	
9	70.00	1.3	-4.7	6.5	0.069	0.	0.201	0.201	0.051	0.051	
10	90.00	-0.6	-6.6	12.2	0.012	0.	0.301	0.301	0.069	0.069	
11	95.00	4.5	-1.4	14.8	0.017	0.	0.527	0.524	0.118	0.117	

TABLE VIII. - Continued. BLADE-ELEMENT DATA AT BLADE EDGES

FOR STATOR 8

(b) 100 Percent of design speed; reading 66

RP	RADII		ABS BETAM		REL BETAM		TOTAL TEMP		TOTAL PRESS	
	IN	OUT	IN	OUT	IN	OUT	IN	RATIO	IN	RATIO
1	23.945	23.947	37.4	6.3	37.4	6.3	356.4	0.990	17.59	0.930
2	23.505	23.538	36.3	3.9	36.3	3.9	349.8	0.998	17.47	0.957
3	21.742	21.902	35.2	1.8	35.2	1.8	345.2	0.999	17.73	0.966
4	20.635	20.884	39.4	0.8	39.4	0.8	344.1	0.994	17.15	0.966
5	20.414	20.681	40.1	-0.1	40.1	-0.1	343.6	0.994	16.87	0.972
6	20.193	20.480	40.2	-0.5	40.2	-0.5	342.5	0.994	16.57	0.984
7	19.972	20.279	40.2	-0.3	40.2	-0.3	340.8	0.998	16.45	0.993
8	19.751	20.079	39.5	-0.4	39.5	-0.4	339.7	0.999	16.59	0.983
9	18.219	18.715	38.7	-1.1	38.7	-1.1	336.8	1.000	16.85	0.971
10	16.520	17.252	42.1	1.1	42.1	1.1	339.5	1.013	17.64	0.963
11	16.111	16.904	45.1	3.5	45.1	3.5	344.6	1.005	18.52	0.894

RP	ABS VEL		REL VEL		MERID VEL		TANG VEL		WHEEL SPEED	
	IN	OUT	IN	OUT	IN	OUT	IN	OUT	IN	OUT
1	264.0	198.2	264.0	198.2	209.6	197.0	160.5	21.9	0.	0.
2	261.2	207.1	261.2	207.1	210.6	206.6	154.6	14.0	0.	0.
3	275.2	217.3	275.2	217.3	224.9	217.2	158.6	6.7	0.	0.
4	268.9	208.9	268.9	208.9	207.6	208.8	170.8	2.9	0.	0.
5	262.7	205.5	262.7	205.5	200.9	205.5	169.3	-0.2	0.	0.
6	256.4	203.8	256.4	203.8	195.7	203.8	165.6	-1.7	0.	0.
7	252.4	205.5	252.4	205.5	192.7	205.5	162.9	-1.1	0.	0.
8	256.6	205.6	256.6	205.6	198.0	205.6	163.2	-1.3	0.	0.
9	267.4	213.5	267.4	213.5	208.7	213.5	167.2	-4.0	0.	0.
10	286.9	231.6	286.9	231.6	212.9	231.5	192.3	4.4	0.	0.
11	302.4	225.3	302.4	225.3	213.5	224.9	214.2	13.6	0.	0.

RP	ABS MACH NO		REL MACH NO		MERID MACH NO		MERID PEAK SS VEL R MACH NO
	IN	OUT	IN	OUT	IN	OUT	
1	0.734	0.541	0.734	0.541	0.583	0.538	0.940 0.939
2	0.733	0.571	0.733	0.571	0.591	0.569	0.981 0.925
3	0.783	0.605	0.783	0.605	0.640	0.605	0.966 0.959
4	0.764	0.582	0.764	0.582	0.590	0.582	1.006 1.038
5	0.745	0.573	0.745	0.573	0.570	0.573	1.023 1.025
6	0.727	0.569	0.727	0.569	0.555	0.569	1.041 0.999
7	0.716	0.574	0.716	0.574	0.547	0.574	1.066 0.979
8	0.731	0.575	0.731	0.575	0.564	0.575	1.038 0.976
9	0.769	0.601	0.769	0.601	0.600	0.601	1.023 1.008
10	0.828	0.649	0.828	0.649	0.615	0.649	1.087 1.168
11	0.872	0.627	0.872	0.627	0.616	0.626	1.053 1.314

RP	PERCENT SPAN	INCIDENCE		DEV	D-FACT	EFF	LOSS COEFF		LOSS PARAM	
		MEAN	SS				TOT	PROF	TOT	PROF
1	5.00	0.6	-5.5	17.4	0.424	0.	0.233	0.233	0.077	0.077
2	10.00	1.1	-5.1	14.1	0.383	0.	0.143	0.143	0.047	0.047
3	30.00	1.3	-4.8	10.7	0.377	0.	0.103	0.103	0.031	0.031
4	42.50	5.1	-1.0	9.5	0.402	0.	0.106	0.106	0.030	0.030
5	45.00	5.7	-0.4	8.6	0.400	0.	0.090	0.090	0.026	0.026
6	47.50	5.7	-0.5	8.2	0.387	0.	0.054	0.054	0.015	0.015
7	50.00	5.5	-0.6	8.3	0.365	0.	0.023	0.023	0.006	0.006
8	52.50	4.6	-1.5	8.3	0.374	0.	0.056	0.056	0.016	0.016
9	70.00	2.5	-3.6	7.2	0.362	0.	0.090	0.090	0.023	0.023
10	90.00	3.2	-2.8	9.2	0.340	0.	0.101	0.101	0.023	0.023
11	95.00	5.2	-0.8	11.6	0.400	0.	0.270	0.268	0.061	0.060

TABLE VIII. - Continued. BLADE-ELEMENT DATA AT BLADE EDGES

FOR STATOR 8

(c) 100 Percent of design speed; reading 59

RP	RADII		ABS BETAM		REL BETAM		TOTAL TEMP		TOTAL PRESS	
	IN	OUT	IN	OUT	IN	OUT	IN	RATIO	IN	RATIO
1	23.945	23.947	40.4	5.1	40.4	5.1	361.2	0.995	18.83	0.931
2	23.505	23.538	37.1	3.8	37.1	3.8	355.2	0.999	18.68	0.960
3	21.742	21.902	38.2	2.2	38.2	2.2	347.8	0.999	18.29	0.979
4	20.635	20.884	41.0	1.5	41.0	1.5	346.3	0.995	17.87	0.971
5	20.414	20.681	41.6	1.0	41.6	1.0	345.8	0.995	17.57	0.978
6	20.193	20.480	41.7	0.8	41.7	0.8	344.7	0.996	17.31	0.987
7	19.972	20.279	42.3	0.8	42.3	0.8	344.3	0.996	17.19	0.990
8	19.751	20.079	41.4	0.8	41.4	0.8	342.3	1.000	17.21	0.987
9	18.219	18.715	40.2	-0.2	40.2	-0.2	338.4	1.000	17.13	0.982
10	16.520	17.252	44.2	1.3	44.2	1.3	339.7	1.011	17.68	0.963
11	16.111	16.904	45.0	3.4	45.0	3.4	345.4	1.003	18.71	0.891

RP	ABS VEL		REL VEL		MERID VEL		TANG VEL		WHEEL SPEED	
	IN	OUT	IN	OUT	IN	OUT	IN	OUT	IN	OUT
1	269.9	193.9	269.9	193.9	205.4	193.1	175.1	17.4	0.	0.
2	267.2	204.3	267.2	204.3	213.2	203.9	161.2	13.4	0.	0.
3	267.1	204.2	267.1	204.2	209.9	204.0	165.1	7.7	0.	0.
4	266.7	197.7	266.7	197.7	201.3	197.7	175.0	5.1	0.	0.
5	261.3	194.7	261.3	194.7	195.2	194.7	173.6	3.6	0.	0.
6	255.8	193.4	255.8	193.4	190.9	193.4	170.2	2.5	0.	0.
7	253.7	193.7	253.7	193.7	187.7	193.7	170.6	2.7	0.	0.
8	255.4	194.4	255.4	194.4	191.6	194.4	168.9	2.8	0.	0.
9	259.5	197.1	259.5	197.1	198.3	197.1	167.4	-0.7	0.	0.
10	277.4	216.0	277.4	216.0	199.0	216.0	193.3	4.8	0.	0.
11	299.2	211.6	299.2	211.6	211.6	211.2	211.6	12.6	0.	0.

RP	ABS MACH NO		REL MACH NO		MERID MACH NO		MERID PEAK SS	
	IN	OUT	IN	OUT	IN	OUT	VEL R	MACH NO
1	0.747	0.524	0.747	0.524	0.568	0.522	0.940	1.036
2	0.746	0.558	0.746	0.558	0.595	0.556	0.956	0.963
3	0.754	0.564	0.754	0.564	0.593	0.563	0.972	1.007
4	0.755	0.547	0.755	0.547	0.569	0.547	0.982	1.066
5	0.738	0.539	0.738	0.539	0.552	0.539	0.997	1.054
6	0.722	0.536	0.722	0.536	0.539	0.535	1.013	1.030
7	0.716	0.537	0.716	0.537	0.530	0.537	1.032	1.030
8	0.724	0.539	0.724	0.539	0.543	0.539	1.015	1.015
9	0.741	0.550	0.741	0.550	0.566	0.550	0.994	1.011
10	0.797	0.602	0.797	0.602	0.572	0.602	1.085	1.181
11	0.861	0.586	0.861	0.586	0.608	0.585	0.998	1.294

RP	PERCENT		INCIDENCE		DEV	D-FACT	EFF	LOSS COEFF		LOSS PARAM	
	SPAN	MEAN	SS	TOT				PROF	TOT	PROF	
1	5.00	3.6	-2.5	16.2	0.476	0.	0.224	0.224	0.074	0.074	
2	10.00	1.9	-4.3	14.0	0.416	0.	0.128	0.128	0.042	0.042	
3	30.00	4.3	-1.8	11.2	0.413	0.	0.067	0.067	0.020	0.020	
4	42.50	6.7	0.6	10.2	0.441	0.	0.092	0.092	0.026	0.026	
5	45.00	7.2	1.1	9.7	0.438	0.	0.074	0.074	0.021	0.021	
6	47.50	7.1	1.0	9.4	0.427	0.	0.044	0.044	0.012	0.012	
7	50.00	7.5	1.4	9.4	0.419	0.	0.035	0.035	0.010	0.010	
8	52.50	6.5	0.4	9.4	0.416	0.	0.044	0.044	0.012	0.012	
9	70.00	3.9	-2.1	8.0	0.403	0.	0.060	0.060	0.015	0.015	
10	90.00	5.2	-0.7	9.4	0.374	0.	0.107	0.107	0.025	0.025	
11	95.00	5.1	-0.8	11.5	0.438	0.	0.285	0.283	0.064	0.064	

TABLE VIII. - Continued. BLADE-ELEMENT DATA AT BLADE EDGES

FOR STATOR 8

(d) 100 Percent of design speed; reading 60

RP	RADII		ABS BETAM		REL BETAM		TOTAL TEMP		TOTAL PRESS	
	IN	OUT	IN	OUT	IN	OUT	IN	RATIO	IN	RATIO
1	23.945	23.947	44.5	6.1	44.5	6.1	367.0	0.989	19.29	0.934
2	23.505	23.538	40.7	4.3	40.7	4.3	358.7	1.000	19.07	0.957
3	21.742	21.902	40.5	2.0	40.5	2.0	350.2	0.999	18.57	0.977
4	20.635	20.884	42.7	1.3	42.7	1.3	348.0	0.996	18.23	0.968
5	20.414	20.681	43.2	0.9	43.2	0.9	347.6	0.996	18.16	0.964
6	20.193	20.480	43.8	0.7	43.8	0.7	348.1	0.993	17.95	0.968
7	19.972	20.279	44.2	0.7	44.2	0.7	346.8	0.994	17.79	0.974
8	19.751	20.079	43.4	0.6	43.4	0.6	345.3	0.996	17.77	0.973
9	18.219	18.715	42.4	-0.4	42.4	-0.4	341.0	0.996	17.54	0.970
10	16.520	17.252	44.1	-1.2	44.1	-1.2	341.0	1.009	17.84	0.955
11	16.111	16.904	46.9	3.6	46.9	3.6	345.6	1.003	18.96	0.885

RP	ABS VEL		REL VEL		MERID VEL		TANG VEL		WHEEL SPEED	
	IN	OUT	IN	OUT	IN	OUT	IN	OUT	IN	OUT
1	270.9	192.2	270.9	192.2	193.3	191.1	189.8	20.5	0.	0.
2	267.8	198.0	267.8	198.0	202.9	197.4	174.7	15.0	0.	0.
3	263.4	195.5	263.4	195.5	200.3	195.3	171.1	6.8	0.	0.
4	263.6	188.4	263.6	188.4	193.9	188.3	178.6	4.3	0.	0.
5	262.2	185.6	262.2	185.6	191.0	185.5	179.6	3.1	0.	0.
6	259.3	183.6	259.3	183.6	187.2	183.6	179.4	2.4	0.	0.
7	256.3	183.3	256.3	183.3	183.7	183.3	178.7	2.2	0.	0.
8	257.0	183.6	257.0	183.6	186.7	183.6	176.6	2.0	0.	0.
9	258.3	185.1	258.3	185.1	190.6	185.1	174.2	-1.2	0.	0.
10	273.9	200.8	273.9	200.8	196.6	200.8	190.7	4.1	0.	0.
11	296.1	198.8	296.1	198.8	202.2	198.4	216.3	12.4	0.	0.

RP	ABS MACH NO		REL MACH NO		MERID MACH NO		MERID PEAK SS	
	IN	OUT	IN	OUT	IN	OUT	VEL R	MACH NO
1	0.743	0.516	0.743	0.516	0.531	0.513	0.988	1.133
2	0.743	0.536	0.743	0.536	0.563	0.535	0.973	1.056
3	0.740	0.536	0.740	0.536	0.562	0.536	0.975	1.048
4	0.743	0.518	0.743	0.518	0.546	0.518	0.971	1.091
5	0.739	0.510	0.739	0.510	0.538	0.510	0.971	1.096
6	0.729	0.505	0.729	0.505	0.526	0.505	0.981	1.091
7	0.721	0.505	0.721	0.505	0.517	0.505	0.998	1.086
8	0.725	0.506	0.725	0.506	0.527	0.506	0.983	1.067
9	0.734	0.514	0.734	0.514	0.542	0.514	0.971	1.059
10	0.784	0.557	0.784	0.557	0.563	0.556	1.021	1.161
11	0.850	0.548	0.850	0.548	0.581	0.547	0.981	1.334

RP	PERCENT		INCIDENCE		DEV	D-FACT	EFF	LOSS COEFF		LOSS PARAM	
	SPAN	MEAN	SS	TOT				PROF	TOT	PROF	
1	5.00	7.7	1.5	17.2	0.498	0.	0.216	0.216	0.071	0.071	
2	10.00	5.5	-0.6	14.5	0.455	0.	0.140	0.140	0.046	0.046	
3	30.00	6.6	0.5	11.0	0.446	0.	0.075	0.075	0.023	0.023	
4	42.50	8.4	2.2	10.0	0.474	0.	0.106	0.106	0.030	0.030	
5	45.00	8.8	2.7	9.6	0.483	0.	0.118	0.118	0.034	0.034	
6	47.50	9.2	3.1	9.4	0.482	0.	0.108	0.108	0.030	0.030	
7	50.00	9.5	3.4	9.3	0.475	0.	0.090	0.090	0.025	0.025	
8	52.50	8.5	2.4	9.3	0.471	0.	0.093	0.093	0.026	0.026	
9	70.00	6.2	0.1	7.8	0.454	0.	0.100	0.100	0.025	0.025	
10	90.00	5.2	-0.7	9.3	0.421	0.	0.136	0.136	0.031	0.031	
11	95.00	7.0	1.1	11.7	0.480	0.	0.305	0.302	0.068	0.068	

TABLE VIII. - Continued. BLADE-ELEMENT DATA AT BLADE EDGES

FOR STATOR 8

(e) 100 Percent of design speed; reading 61

RP	RADII		ABS BETAM		REL BETAM		TOTAL TEMP		TOTAL PRESS	
	IN	OUT	IN	OUT	IN	OUT	IN	RATIO	IN	RATIO
1	23.945	23.947	47.6	7.2	47.6	7.2	371.2	0.996	19.61	0.942
2	23.505	23.538	44.6	4.2	44.6	4.2	364.2	1.000	19.57	0.952
3	21.742	21.902	43.0	2.1	43.0	2.1	353.1	1.001	18.94	0.968
4	20.635	20.884	44.0	1.2	44.0	1.2	350.0	0.998	18.56	0.961
5	20.414	20.681	44.7	1.0	44.7	1.0	349.5	0.996	18.41	0.962
6	20.193	20.480	45.5	0.8	45.5	0.8	349.6	0.994	18.32	0.961
7	19.972	20.279	46.2	0.6	46.2	0.6	349.5	0.992	18.24	0.961
8	19.751	20.079	45.4	0.8	45.4	0.8	348.2	0.993	18.25	0.958
9	18.219	18.715	44.3	-0.3	44.3	-0.3	342.3	0.996	17.82	0.961
10	16.520	17.252	46.3	1.6	46.3	1.6	342.4	1.007	18.13	0.943
11	16.111	16.904	48.3	3.2	48.3	3.2	347.5	1.000	19.15	0.884

RP	ABS VEL		REL VEL		MERID VEL		TANG VEL		WHEEL SPEED	
	IN	OUT	IN	OUT	IN	OUT	IN	OUT	IN	OUT
1	268.7	191.7	268.7	191.7	181.1	190.2	198.5	24.1	0.	0.
2	268.1	194.5	268.1	194.5	190.9	194.0	188.3	14.2	0.	0.
3	261.6	187.1	261.6	187.1	191.4	187.0	178.4	6.8	0.	0.
4	260.5	178.2	260.5	178.2	187.3	178.1	181.0	3.8	0.	0.
5	257.9	175.3	257.9	175.3	183.2	175.3	181.5	2.9	0.	0.
6	256.6	173.4	256.6	173.4	179.7	173.4	183.2	2.4	0.	0.
7	256.3	172.3	256.3	172.3	177.3	172.3	185.1	1.9	0.	0.
8	257.7	172.1	257.7	172.1	180.8	172.1	183.6	2.3	0.	0.
9	254.5	170.7	254.5	170.7	182.2	170.7	177.6	-1.0	0.	0.
10	270.6	184.0	270.6	184.0	187.1	184.0	195.5	5.0	0.	0.
11	292.2	183.0	292.2	183.0	194.3	182.8	218.3	10.1	0.	0.

RP	ABS MACH NO		REL MACH NO		MERID MACH NO		MERID PEAK-SS VEL R MACH NO	
	IN	OUT	IN	OUT	IN	OUT	IN	OUT
1	0.732	0.510	0.732	0.510	0.493	0.506	1.050	1.194
2	0.738	0.522	0.738	0.522	0.525	0.521	1.016	1.146
3	0.731	0.509	0.731	0.509	0.535	0.509	0.977	1.098
4	0.731	0.487	0.731	0.487	0.526	0.487	0.951	1.107
5	0.723	0.479	0.723	0.479	0.514	0.479	0.957	1.109
6	0.719	0.474	0.719	0.474	0.504	0.474	0.965	1.119
7	0.718	0.472	0.718	0.472	0.497	0.472	0.972	1.130
8	0.724	0.472	0.724	0.472	0.508	0.472	0.952	1.115
9	0.721	0.471	0.721	0.471	0.516	0.471	0.937	1.085
10	0.772	0.507	0.772	0.507	0.534	0.507	0.983	1.198
11	0.835	0.502	0.835	0.502	0.555	0.501	0.941	1.349

RP	PERCENT	INCIDENCE		DEV	D-FACT	EFF	LOSS COEFF		LOSS PARAM	
	SPAN	MEAN	SS				TOT	PROF	TOT	PROF
1	5.00	10.8	4.7	18.3	0.502	0.	0.194	0.194	0.064	0.064
2	10.00	9.4	3.3	14.4	0.486	0.	0.159	0.159	0.052	0.052
3	30.00	9.1	3.0	11.1	0.482	0.	0.106	0.106	0.032	0.032
4	42.50	9.7	3.6	10.0	0.510	0.	0.130	0.130	0.037	0.037
5	45.00	10.3	4.2	9.7	0.516	0.	0.128	0.128	0.036	0.036
6	47.50	11.0	4.8	9.5	0.521	0.	0.133	0.133	0.037	0.037
7	50.00	11.5	5.4	9.3	0.525	0.	0.134	0.134	0.037	0.037
8	52.50	10.5	4.4	9.4	0.524	0.	0.144	0.144	0.040	0.040
9	70.00	8.0	2.0	7.9	0.505	0.	0.133	0.133	0.034	0.034
10	90.00	7.3	1.4	9.7	0.479	0.	0.176	0.176	0.041	0.041
11	95.00	8.4	2.5	11.3	0.530	0.	0.317	0.315	0.071	0.071

TABLE VIII. - Continued. BLADE-ELEMENT DATA AT BLADE EDGES

FOR STATOR 8

(f) 100 Percent of design speed; reading 62

RP	RADII		ABS BETAM		REL BETAM		TOTAL TEMP		TOTAL PRESS	
	IN	OUT	IN	OUT	IN	OUT	IN	RATIO	IN	RATIO
1	23.945	23.947	53.9	7.6	53.9	7.6	377.0	0.990	19.76	0.939
2	23.505	23.538	47.5	5.2	47.5	5.2	368.6	0.999	19.66	0.941
3	21.742	21.902	45.0	2.6	45.0	2.6	355.3	1.001	19.03	0.961
4	20.635	20.884	45.4	1.1	45.4	1.1	351.4	0.996	18.70	0.952
5	20.414	20.681	46.2	1.0	46.2	1.0	350.9	0.995	18.58	0.954
6	20.193	20.480	47.0	1.0	47.0	1.0	351.1	0.992	18.48	0.953
7	19.972	20.279	47.4	1.2	47.4	1.2	350.6	0.992	18.36	0.955
8	19.751	20.079	46.8	1.4	46.8	1.4	349.2	0.994	18.40	0.951
9	18.219	18.715	45.8	-0.4	45.8	-0.4	344.0	0.992	17.98	0.953
10	16.520	17.252	47.1	1.5	47.1	1.5	343.7	1.006	18.21	0.939
11	16.111	16.904	48.7	2.7	48.7	2.7	347.9	1.000	19.34	0.878

RP	ABS VEL		REL VEL		MERID VEL		TANG VEL		WHEEL SPEED	
	IN	OUT	IN	OUT	IN	OUT	IN	OUT	IN	OUT
1	266.5	188.7	266.5	188.7	156.9	187.0	215.4	25.1	0.	0.
2	265.0	186.2	265.0	186.2	179.2	185.4	195.3	16.9	0.	0.
3	259.1	179.8	259.1	179.8	183.2	179.6	183.2	8.0	0.	0.
4	258.0	169.0	258.0	169.0	181.2	169.0	183.6	3.3	0.	0.
5	255.8	167.1	255.8	167.1	177.2	167.1	184.5	2.9	0.	0.
6	255.3	164.7	255.3	164.7	174.2	164.6	186.6	3.0	0.	0.
7	254.0	163.5	254.0	163.5	171.9	163.5	187.0	3.3	0.	0.
8	254.9	163.0	254.9	163.0	174.7	162.9	185.7	4.0	0.	0.
9	252.1	159.6	252.1	159.6	175.7	159.6	180.8	-1.1	0.	0.
10	267.7	174.3	267.7	174.3	182.2	174.2	196.1	4.5	0.	0.
11	292.3	174.7	292.3	174.7	192.9	174.5	219.6	8.4	0.	0.

RP	ABS MACH NO		REL MACH NO		MERID MACH NO		MERID PEAK SS VEL R MACH NO	
	IN	OUT	IN	OUT	IN	OUT		
1	0.719	0.499	0.719	0.499	0.423	0.495	1.192	1.328
2	0.724	0.496	0.724	0.496	0.489	0.494	1.035	1.194
3	0.721	0.487	0.721	0.487	0.510	0.486	0.980	1.132
4	0.721	0.460	0.721	0.460	0.507	0.460	0.933	1.127
5	0.715	0.455	0.715	0.455	0.495	0.455	0.943	1.132
6	0.713	0.449	0.713	0.449	0.487	0.449	0.945	1.145
7	0.710	0.446	0.710	0.446	0.481	0.446	0.951	1.145
8	0.715	0.445	0.715	0.445	0.490	0.445	0.933	1.132
9	0.712	0.439	0.712	0.439	0.496	0.439	0.909	1.108
10	0.761	0.478	0.761	0.478	0.518	0.478	0.956	1.203
11	0.835	0.478	0.835	0.478	0.551	0.477	0.904	1.359

RP	PERCENT INCIDENCE		DEV	D-FACT	EFF	LOSS COEFF		LOSS PARAM		
	SPAN	MEAN SS				TOT	PROF	TOT	PROF	
1	5.00	17.1	11.0	18.7	0.529	0.	0.208	0.208	0.069	0.069
2	10.00	12.2	6.1	15.4	0.517	0.	0.202	0.202	0.066	0.066
3	30.00	11.1	5.0	11.5	0.510	0.	0.132	0.132	0.040	0.040
4	42.50	11.1	5.0	9.8	0.545	0.	0.165	0.165	0.047	0.047
5	45.00	11.7	5.6	9.7	0.547	0.	0.160	0.160	0.046	0.046
6	47.50	12.4	6.3	9.7	0.556	0.	0.164	0.164	0.046	0.046
7	50.00	12.7	6.6	9.8	0.556	0.	0.158	0.158	0.044	0.044
8	52.50	11.8	5.7	10.0	0.555	0.	0.170	0.170	0.047	0.047
9	70.00	9.6	3.5	7.8	0.548	0.	0.164	0.164	0.042	0.042
10	90.00	8.2	2.2	9.6	0.510	0.	0.191	0.191	0.044	0.044
11	95.00	8.8	2.9	10.9	0.561	0.	0.333	0.330	0.075	0.074

TABLE VIII. - Continued. BLADE-ELEMENT DATA AT BLADE EDGES

FOR STATOR 8

(g) 90 Percent of design speed; reading 69

RP	RADII		ABS BETAM		REL BETAM		TOTAL TEMP		TOTAL PRESS	
	IN	OUT	IN	OUT	IN	OUT	IN	RATIO	IN	RATIO
1	23.945	23.947	32.2	7.0	32.2	7.0	338.4	0.994	15.69	0.927
2	23.505	23.538	30.8	4.3	30.8	4.3	335.5	0.995	15.65	0.949
3	21.742	21.902	31.4	1.0	31.4	1.0	330.7	0.998	15.57	0.964
4	20.635	20.884	34.6	-0.1	34.6	-0.1	331.0	0.996	15.53	0.967
5	20.414	20.681	35.8	-0.3	35.8	-0.3	330.8	0.996	15.40	0.970
6	20.193	20.480	36.8	-0.7	36.8	-0.7	330.7	0.995	15.22	0.978
7	19.972	20.279	36.7	-1.0	36.7	-1.0	329.9	0.996	15.03	0.989
8	19.751	20.079	35.9	-1.3	35.9	-1.3	328.2	1.000	15.15	0.981
9	18.219	18.715	35.4	-2.1	35.4	-2.1	326.0	1.001	15.17	0.978
10	16.520	17.252	39.0	1.4	39.0	1.4	329.7	1.011	15.99	0.941
11	16.111	16.904	43.1	5.2	43.1	5.2	333.8	1.005	16.64	0.875

RP	ABS VEL		REL VEL		MERID VEL		TANG VEL		WHEEL SPEED	
	IN	OUT	IN	OUT	IN	OUT	IN	OUT	IN	OUT
1	246.1	214.5	246.1	214.5	208.3	212.9	131.1	26.2	0.	0.
2	245.8	222.2	245.8	222.2	211.2	221.5	125.7	16.8	0.	0.
3	248.5	227.0	248.5	227.0	212.2	227.0	129.4	4.1	0.	0.
4	253.2	232.1	253.2	232.1	208.5	232.1	143.8	-0.5	0.	0.
5	250.2	231.4	250.2	231.4	202.9	231.4	146.5	-1.2	0.	0.
6	245.8	231.1	245.8	231.1	196.8	231.0	147.2	-2.7	0.	0.
7	240.7	231.8	240.7	231.8	193.0	231.8	143.8	-4.0	0.	0.
8	244.6	233.0	244.6	233.0	198.1	232.9	143.5	-5.2	0.	0.
9	249.8	244.0	249.8	244.0	203.6	243.8	144.8	-8.8	0.	0.
10	281.0	277.7	281.0	277.7	218.5	277.6	176.7	7.0	0.	0.
11	289.7	273.9	289.7	273.9	211.4	272.8	198.1	24.9	0.	0.

RP	ABS MACH NO		REL MACH NO		MERID MACH NO		MERID PEAK SS	
	IN	OUT	IN	OUT	IN	OUT	VEL R	MACH NO
1	0.699	0.604	0.699	0.604	0.592	0.600	1.022	0.727
2	0.702	0.630	0.702	0.630	0.603	0.629	1.049	0.732
3	0.716	0.649	0.716	0.649	0.611	0.649	1.070	0.745
4	0.731	0.665	0.731	0.665	0.601	0.665	1.113	0.858
5	0.721	0.664	0.721	0.664	0.585	0.664	1.141	0.879
6	0.707	0.663	0.707	0.663	0.566	0.663	1.174	0.883
7	0.692	0.666	0.692	0.666	0.555	0.665	1.201	0.857
8	0.706	0.670	0.706	0.670	0.572	0.669	1.176	0.848
9	0.726	0.707	0.726	0.707	0.592	0.706	1.197	0.860
10	0.823	0.807	0.823	0.807	0.640	0.806	1.270	1.069
11	0.846	0.791	0.846	0.791	0.617	0.788	1.290	1.218

RP	PERCENT		INCIDENCE		DEV	D-FACT	EFF	LOSS COEFF		LOSS PARAM	
	SPAN	MEAN	SS	TOT				PROF	TOT	PROF	
1	5.00	-4.6	-10.7	18.1	0.270	0.	0.263	0.263	0.087	0.087	
2	10.00	-4.5	-10.6	14.5	0.240	0.	0.181	0.181	0.059	0.059	
3	30.00	-2.5	-8.7	10.0	0.238	0.	0.123	0.123	0.037	0.037	
4	42.50	0.3	-5.8	8.6	0.246	0.	0.111	0.111	0.032	0.032	
5	45.00	1.4	-4.7	8.4	0.242	0.	0.101	0.101	0.029	0.029	
6	47.50	2.2	-3.9	8.0	0.230	0.	0.079	0.079	0.022	0.022	
7	50.00	2.0	-4.2	7.6	0.207	0.	0.041	0.041	0.011	0.011	
8	52.50	1.0	-5.1	7.3	0.214	0.	0.066	0.066	0.018	0.018	
9	70.00	-0.8	-6.9	6.2	0.178	0.	0.075	0.075	0.019	0.019	
10	90.00	0.0	-5.9	9.6	0.148	0.	0.164	0.164	0.038	0.038	
11	95.00	3.2	-2.7	13.3	0.185	0.	0.334	0.334	0.075	0.075	

TABLE VIII. - Continued. BLADE-ELEMENT DATA AT BLADE EDGES

FOR STATOR 8

(h) 90 Percent of design speed; reading 70

RP	RADII		ABS BETAM		REL BETAM		TOTAL TEMP		TOTAL PRESS	
	IN	OUT	IN	OUT	IN	OUT	IN	RATIO	IN	RATIO
1	23.945	23.947	36.0	6.3	36.0	6.3	343.4	0.991	16.39	0.944
2	23.505	23.538	34.1	4.3	34.1	4.3	338.5	0.996	16.26	0.966
3	21.742	21.902	34.4	1.1	34.4	1.1	332.9	0.999	16.05	0.981
4	20.635	20.884	36.6	0.8	36.6	0.8	332.2	0.998	15.93	0.982
5	20.414	20.681	37.4	0.9	37.4	0.9	332.4	0.998	15.83	0.983
6	20.193	20.480	38.4	0.8	38.4	0.8	332.5	0.997	15.72	0.987
7	19.972	20.279	38.8	0.6	38.8	0.6	331.9	0.997	15.57	0.993
8	19.751	20.079	37.8	0.5	37.8	0.5	330.5	1.000	15.63	0.988
9	18.219	18.715	37.9	-1.2	37.9	-1.2	328.0	0.999	15.48	0.989
10	16.520	17.252	41.1	0.7	41.1	0.7	330.5	1.010	16.18	0.979
11	16.111	16.904	44.0	3.4	44.0	3.4	334.5	1.005	16.83	0.918

RP	ABS VEL		REL VEL		MERID VEL		TANG VEL		WHEEL SPEED	
	IN	OUT	IN	OUT	IN	OUT	IN	OUT	IN	OUT
1	247.3	190.1	247.3	190.1	200.0	189.0	145.5	21.0	0.	0.
2	244.0	197.0	244.0	197.0	202.0	196.4	136.9	14.7	0.	0.
3	243.8	199.3	243.8	199.3	201.2	199.2	137.7	3.7	0.	0.
4	247.0	201.1	247.0	201.1	198.3	201.1	147.3	2.9	0.	0.
5	245.1	200.1	245.1	200.1	194.8	200.1	148.8	3.0	0.	0.
6	242.3	199.5	242.3	199.5	189.8	199.5	150.7	2.6	0.	0.
7	239.4	199.2	239.4	199.2	186.5	199.2	150.1	2.2	0.	0.
8	241.6	199.0	241.6	199.0	190.9	199.0	148.2	1.7	0.	0.
9	242.3	202.7	242.3	202.7	191.3	202.6	148.7	-4.3	0.	0.
10	268.2	232.0	268.2	232.0	202.1	232.0	176.4	2.9	0.	0.
11	280.9	228.1	280.9	228.1	202.0	227.7	195.2	13.7	0.	0.

RP	ABS MACH NO		REL MACH NO		MERID MACH NO		MERID PEAK SS VEL R MACH NO	
	IN	OUT	IN	OUT	IN	OUT		
1	0.697	0.528	0.697	0.528	0.564	0.525	0.945	0.855
2	0.693	0.551	0.693	0.551	0.573	0.550	0.972	0.815
3	0.698	0.562	0.698	0.562	0.576	0.562	0.990	0.833
4	0.709	0.568	0.709	0.568	0.569	0.568	1.014	0.890
5	0.703	0.565	0.703	0.565	0.559	0.565	1.027	0.898
6	0.694	0.564	0.694	0.564	0.544	0.564	1.051	0.910
7	0.686	0.563	0.686	0.563	0.534	0.563	1.068	0.903
8	0.694	0.563	0.694	0.563	0.548	0.563	1.043	0.885
9	0.699	0.577	0.699	0.577	0.552	0.577	1.059	0.895
10	0.779	0.661	0.779	0.661	0.587	0.661	1.148	1.073
11	0.815	0.646	0.815	0.646	0.586	0.645	1.127	1.199

RP	PERCENT SPAN		INCIDENCE		DEV	D-FACT	EFF	LOSS COEFF		LOSS PARAM	
	SPAN	MEAN	MEAN	SS				TOT	PROF	TOT	PROF
1	5.00	-0.8	-6.9	17.4	0.399	0.	0.201	0.201	0.066	0.066	
2	10.00	-1.1	-7.2	14.5	0.356	0.	0.124	0.124	0.041	0.041	
3	30.00	0.5	-5.6	10.0	0.348	0.	0.069	0.069	0.021	0.021	
4	42.50	2.3	-3.8	9.6	0.353	0.	0.063	0.063	0.018	0.018	
5	45.00	2.9	-3.2	9.6	0.352	0.	0.059	0.059	0.017	0.017	
6	47.50	3.9	-2.3	9.4	0.347	0.	0.047	0.047	0.013	0.013	
7	50.00	4.1	-2.0	9.3	0.339	0.	0.025	0.025	0.007	0.007	
8	52.50	2.9	-3.2	9.1	0.342	0.	0.044	0.044	0.012	0.012	
9	70.00	1.6	-4.4	7.0	0.322	0.	0.039	0.039	0.010	0.010	
10	90.00	2.2	-3.8	8.8	0.281	0.	0.063	0.063	0.015	0.015	
11	95.00	4.1	-1.8	11.5	0.329	0.	0.230	0.230	0.052	0.052	

TABLE VIII. - Continued. BLADE-ELEMENT DATA AT BLADE EDGES

FOR STATOR 8

(i) 90 Percent of design speed; reading 71

RP	RADII		ABS BETAM		REL BETAM		TOTAL TEMP		TOTAL PRESS	
	IN	OUT	IN	OUT	IN	OUT	IN	RATIO	IN	RATIO
1	23.945	23.947	39.3	5.2	39.3	5.2	346.8	0.994	16.78	0.949
2	23.505	23.538	37.3	4.0	37.3	4.0	342.2	0.998	16.70	0.972
3	21.742	21.902	37.1	1.5	37.1	1.5	335.3	1.000	16.36	0.984
4	20.635	20.884	38.6	1.5	38.6	1.5	334.2	0.999	16.29	0.979
5	20.414	20.681	39.4	1.3	39.4	1.3	334.0	0.999	16.19	0.982
6	20.193	20.480	40.2	1.2	40.2	1.2	334.5	0.996	16.09	0.984
7	19.972	20.279	40.7	0.9	40.7	0.9	333.9	0.996	16.01	0.986
8	19.751	20.079	40.0	0.6	40.0	0.6	332.4	0.999	16.06	0.981
9	18.219	18.715	39.9	-0.8	39.9	-0.8	330.2	0.996	15.89	0.975
10	16.520	17.252	43.3	0.7	43.3	0.7	331.6	1.006	16.32	0.966
11	16.111	16.904	45.7	3.4	45.7	3.4	335.5	1.001	17.02	0.913

RP	ABS VEL		REL VEL		MERID VEL		TANG VEL		WHEEL SPEED	
	IN	OUT	IN	OUT	IN	OUT	IN	OUT	IN	OUT
1	243.7	181.7	243.7	181.7	188.6	180.9	154.3	16.4	0.	0.
2	242.4	190.7	242.4	190.7	192.7	190.2	147.0	13.5	0.	0.
3	238.7	187.3	238.7	187.3	190.4	187.3	144.0	4.8	0.	0.
4	243.4	188.0	243.4	188.0	190.4	187.9	151.7	5.0	0.	0.
5	241.1	187.2	241.1	187.2	186.3	187.1	153.1	4.1	0.	0.
6	239.8	186.9	239.8	186.9	183.2	186.8	154.7	3.8	0.	0.
7	238.7	186.2	238.7	186.2	180.9	186.2	155.8	2.9	0.	0.
8	240.5	186.1	240.5	186.1	184.2	186.1	154.6	2.0	0.	0.
9	242.0	186.1	242.0	186.1	185.5	186.0	155.4	-2.7	0.	0.
10	260.1	206.4	260.1	206.4	189.2	206.4	178.4	2.6	0.	0.
11	275.6	205.1	275.6	205.1	192.4	204.7	197.3	12.2	0.	0.

RP	ABS MACH NO		REL MACH NO		MERID MACH NO		MERID PEAK SS	
	IN	OUT	IN	OUT	IN	OUT	VEL R	MACH NO
1	0.683	0.500	0.683	0.500	0.528	0.498	0.959	0.918
2	0.683	0.529	0.683	0.529	0.543	0.528	0.987	0.889
3	0.680	0.524	0.680	0.524	0.542	0.524	0.984	0.882
4	0.696	0.527	0.696	0.527	0.544	0.527	0.987	0.922
5	0.689	0.525	0.689	0.525	0.532	0.525	1.005	0.930
6	0.684	0.525	0.684	0.525	0.523	0.524	1.020	0.939
7	0.681	0.523	0.681	0.523	0.516	0.523	1.030	0.944
8	0.689	0.523	0.689	0.523	0.527	0.523	1.010	0.932
9	0.696	0.526	0.696	0.526	0.533	0.526	1.003	0.943
10	0.752	0.583	0.752	0.583	0.547	0.583	1.091	1.092
11	0.797	0.576	0.797	0.576	0.556	0.575	1.064	1.217

RP	PERCENT		INCIDENCE		DEV	D-FACT	EFF	LOSS COEFF		LOSS PARAM	
	SPAN		MEAN	SS				TOT	PROF	TOT	PROF
1	5.00		2.5	-3.7	16.3	0.442	0.	0.189	0.189	0.062	0.062
2	10.00		2.1	-4.0	14.2	0.395	0.	0.104	0.104	0.034	0.034
3	30.00		3.2	-2.9	10.4	0.391	0.	0.059	0.059	0.018	0.018
4	42.50		4.3	-1.9	10.3	0.400	0.	0.074	0.074	0.021	0.021
5	45.00		5.0	-1.1	10.0	0.398	0.	0.068	0.068	0.019	0.019
6	47.50		5.6	-0.5	9.8	0.396	0.	0.059	0.059	0.017	0.017
7	50.00		6.0	-0.1	9.5	0.397	0.	0.054	0.054	0.015	0.015
8	52.50		5.1	-1.0	9.2	0.399	0.	0.071	0.071	0.019	0.019
9	70.00		3.7	-2.4	7.4	0.395	0.	0.090	0.090	0.023	0.023
10	90.00		4.4	-1.6	8.8	0.359	0.	0.107	0.107	0.025	0.025
11	95.00		5.8	-0.1	11.5	0.403	0.	0.255	0.255	0.057	0.057

TABLE VIII. - Continued. BLADE-ELEMENT DATA AT BLADE EDGES

FOR STATOR 8

(j) 90 Percent of design speed; reading 72

RP	RADII		ABS BETAM		REL BETAM		TOTAL TEMP		TOTAL PRESS	
	IN	OUT	IN	OUT	IN	OUT	IN	RATIO	IN	RATIO
1	23.945	23.947	45.7	6.8	45.7	6.8	351.9	0.999	17.17	0.959
2	23.505	23.538	43.0	4.2	43.0	4.2	347.7	0.999	17.14	0.970
3	21.742	21.902	41.1	1.6	41.1	1.6	338.5	1.002	16.71	0.985
4	20.635	20.884	41.3	1.4	41.3	1.4	336.1	1.000	16.61	0.976
5	20.414	20.681	42.2	1.3	42.2	1.3	336.1	0.998	16.56	0.974
6	20.193	20.480	43.3	1.2	43.3	1.2	336.4	0.995	16.42	0.976
7	19.972	20.279	43.8	1.0	43.8	1.0	336.2	0.994	16.41	0.976
8	19.751	20.079	43.2	0.8	43.2	0.8	334.8	0.996	16.37	0.974
9	18.219	18.715	43.3	-1.0	43.3	-1.0	330.9	0.998	15.98	0.977
10	16.520	17.252	44.4	1.4	44.4	1.4	332.1	1.004	16.38	0.958
11	16.111	16.904	47.5	3.6	47.5	3.6	335.8	0.999	17.16	0.906

RP	ABS VEL		REL VEL		MERID VEL		TANG VEL		WHEEL SPEED	
	IN	OUT	IN	OUT	IN	OUT	IN	OUT	IN	OUT
1	239.1	175.7	239.1	175.7	166.9	174.5	171.2	20.7	0.	0.
2	238.5	180.5	238.5	180.5	174.3	180.0	162.8	13.3	0.	0.
3	233.5	176.0	233.5	176.0	176.1	175.9	153.4	5.0	0.	0.
4	237.0	172.4	237.0	172.4	178.0	172.4	156.6	4.1	0.	0.
5	236.5	171.2	236.5	171.2	175.2	171.2	158.8	3.9	0.	0.
6	234.2	174.5	234.2	174.5	170.3	174.4	160.7	3.6	0.	0.
7	234.3	169.9	234.3	169.9	169.0	169.8	162.3	2.9	0.	0.
8	234.4	168.3	234.4	168.3	170.8	168.3	160.6	2.3	0.	0.
9	229.9	164.4	229.9	164.4	167.5	164.4	157.6	-3.0	0.	0.
10	249.6	180.5	249.6	180.5	178.3	180.5	174.7	4.3	0.	0.
11	268.3	179.9	268.3	179.9	181.4	179.5	197.7	11.4	0.	0.

RP	ABS MACH NO		REL MACH NO		MERID MACH NO		MERID PEAK SS	
	IN	OUT	IN	OUT	IN	OUT	VEL R	MACH NO
1	0.663	0.478	0.663	0.478	0.463	0.475	1.045	1.039
2	0.666	0.495	0.666	0.495	0.486	0.493	1.033	0.998
3	0.660	0.488	0.660	0.488	0.498	0.488	0.999	0.949
4	0.674	0.480	0.674	0.480	0.506	0.480	0.969	0.959
5	0.672	0.477	0.672	0.477	0.498	0.477	0.977	0.973
6	0.664	0.487	0.664	0.487	0.483	0.487	1.024	0.984
7	0.665	0.474	0.665	0.474	0.480	0.474	1.005	0.993
8	0.667	0.470	0.667	0.470	0.486	0.470	0.986	0.978
9	0.657	0.461	0.657	0.461	0.479	0.461	0.982	0.966
10	0.718	0.506	0.718	0.506	0.512	0.505	1.012	1.070
11	0.773	0.502	0.773	0.502	0.523	0.501	0.990	1.226

RP	PERCENT	INCIDENCE		DEV	D-FACT	EFF	LOSS COEFF		LOSS PARAM	
	SPAN	MEAN	SS				TOT	PROF	TOT	PROF
1	5.00	8.9	2.8	17.8	0.474	0.	0.162	0.162	0.054	0.054
2	10.00	7.8	1.7	14.4	0.447	0.	0.117	0.117	0.038	0.038
3	30.00	7.2	1.0	10.6	0.438	0.	0.058	0.058	0.017	0.017
4	42.50	7.0	0.9	10.1	0.456	0.	0.093	0.093	0.027	0.027
5	45.00	7.8	1.6	10.0	0.461	0.	0.101	0.101	0.029	0.029
6	47.50	8.8	2.6	9.8	0.442	0.	0.095	0.095	0.027	0.027
7	50.00	9.1	3.0	9.6	0.463	0.	0.092	0.092	0.026	0.026
8	52.50	8.3	2.2	9.4	0.466	0.	0.102	0.102	0.028	0.028
9	70.00	7.0	0.9	7.2	0.460	0.	0.093	0.093	0.024	0.024
10	90.00	5.5	-0.4	9.5	0.431	0.	0.143	0.143	0.033	0.033
11	95.00	7.5	1.6	11.7	0.481	0.	0.287	0.287	0.064	0.064

TABLE VIII. - Continued. BLADE-ELEMENT DATA AT BLADE EDGES

FOR STATOR 8

(k) 90 Percent of design speed; reading 73

RP	RADII		ABS BETAM		REL BETAM		TOTAL TEMP		TOTAL PRESS	
	IN	OUT	IN	OUT	IN	OUT	IN	RATIO	IN	RATIO
1	23.945	23.947	52.3	7.8	52.3	7.8	358.7	0.991	17.38	0.959
2	23.505	23.538	47.4	4.7	47.4	4.7	352.0	0.998	17.31	0.962
3	21.742	21.902	43.7	2.0	43.7	2.0	340.6	1.001	16.87	0.977
4	20.635	20.884	44.0	1.7	44.0	1.7	338.0	0.997	16.65	0.967
5	20.414	20.681	45.0	1.5	45.0	1.5	337.8	0.996	16.56	0.967
6	20.193	20.480	45.7	1.4	45.7	1.4	338.2	0.993	16.49	0.967
7	19.972	20.279	46.5	1.0	46.5	1.0	337.6	0.992	16.41	0.966
8	19.751	20.079	46.4	0.6	46.4	0.6	336.5	0.993	16.38	0.962
9	18.219	18.715	46.1	-0.5	46.1	-0.5	332.2	0.999	15.96	0.979
10	16.520	17.252	46.9	1.3	46.9	1.3	332.1	1.004	16.41	0.953
11	16.111	16.904	48.0	2.7	48.0	2.7	335.7	1.000	17.20	0.903

RP	ABS VEL		REL VEL		MERID VEL		TANG VEL		WHEEL SPEED	
	IN	OUT	IN	OUT	IN	OUT	IN	OUT	IN	OUT
1	237.6	173.4	237.6	173.4	145.4	171.8	187.9	23.5	0.	0.
2	236.6	172.9	236.6	172.9	160.2	172.4	174.2	14.3	0.	0.
3	231.1	167.1	231.1	167.1	167.1	167.0	159.7	5.9	0.	0.
4	230.6	157.4	230.6	157.4	165.9	157.3	160.1	4.7	0.	0.
5	229.4	155.8	229.4	155.8	162.3	155.7	162.1	4.0	0.	0.
6	228.6	153.9	228.6	153.9	159.8	153.8	163.5	3.8	0.	0.
7	227.5	151.2	227.5	151.2	156.6	151.2	165.1	2.6	0.	0.
8	227.3	149.2	227.3	149.2	156.6	149.2	164.7	1.6	0.	0.
9	221.4	151.3	221.4	151.3	153.6	151.3	159.4	-1.3	0.	0.
10	243.0	164.9	243.0	164.9	166.1	164.9	177.3	3.7	0.	0.
11	264.5	165.1	264.5	165.1	176.9	164.9	196.7	7.7	0.	0.

RP	ABS MACH NO		REL MACH NO		MERID MACH NO		MERID PEAK SS VEL R MACH NO
	IN	OUT	IN	OUT	IN	OUT	
1	0.652	0.469	0.652	0.469	0.399	0.464	1.182 1.167
2	0.656	0.470	0.656	0.470	0.444	0.469	1.076 1.080
3	0.651	0.461	0.651	0.461	0.470	0.461	1.000 0.993
4	0.652	0.436	0.652	0.436	0.469	0.436	0.948 0.987
5	0.648	0.432	0.648	0.432	0.459	0.431	0.959 1.000
6	0.646	0.426	0.646	0.426	0.451	0.426	0.963 1.007
7	0.643	0.419	0.643	0.419	0.442	0.419	0.966 1.017
8	0.643	0.414	0.643	0.414	0.443	0.414	0.953 1.012
9	0.630	0.422	0.630	0.422	0.437	0.422	0.985 0.986
10	0.697	0.460	0.697	0.460	0.476	0.460	0.993 1.096
11	0.761	0.459	0.761	0.459	0.509	0.458	0.932 1.222

RP	PERCENT SPAN		INCIDENCE		DEV	D-FACT	EFF	LOSS COEFF		LOSS PARAM	
	SPAN	MEAN	MEAN	SS				TOT	PROF	TOT	PROF
1	5.00	15.5	9.3	18.8	0.500	0.	0.165	0.165	0.054	0.054	
2	10.00	12.2	6.0	14.9	0.490	0.	0.151	0.151	0.049	0.049	
3	30.00	9.8	3.7	11.0	0.477	0.	0.094	0.094	0.028	0.028	
4	42.50	9.7	3.6	10.5	0.510	0.	0.134	0.134	0.039	0.039	
5	45.00	10.5	4.4	10.2	0.516	0.	0.133	0.133	0.038	0.038	
6	47.50	11.1	4.9	10.1	0.522	0.	0.137	0.137	0.039	0.039	
7	50.00	11.8	5.7	9.6	0.532	0.	0.141	0.141	0.039	0.039	
8	52.50	11.5	5.4	9.2	0.539	0.	0.154	0.154	0.043	0.043	
9	70.00	9.8	3.8	7.7	0.499	0.	0.088	0.088	0.022	0.022	
10	90.00	8.0	2.0	9.4	0.482	0.	0.170	0.170	0.039	0.039	
11	95.00	8.1	2.2	10.8	0.532	0.	0.305	0.305	0.069	0.069	

TABLE VIII. - Continued. BLADE-ELEMENT DATA AT BLADE EDGES

FOR STATOR 8

(1) 80 Percent of design speed; reading 81

RP	RADII		ABS BETAM		REL BETAM		TOTAL TEMP		TOTAL PRESS	
	IN	OUT	IN	OUT	IN	OUT	IN	RATIO	IN	RATIO
1	23.945	23.947	50.1	7.5	50.1	7.5	340.8	0.997	15.34	0.971
2	23.505	23.538	45.7	4.9	45.7	4.9	337.4	0.998	15.34	0.973
3	21.742	21.902	43.2	1.1	43.2	1.1	328.6	1.000	14.90	0.986
4	20.635	20.884	45.1	0.4	45.1	0.4	327.3	0.996	14.81	0.973
5	20.414	20.681	45.9	0.2	45.9	0.2	326.7	0.996	14.74	0.974
6	20.193	20.480	46.8	0.1	46.8	0.1	326.8	0.995	14.65	0.978
7	19.972	20.279	47.9	0.0	47.9	0.0	326.2	0.996	14.58	0.981
8	19.751	20.079	48.2	0.0	48.2	0.0	326.8	0.994	14.60	0.978
9	18.219	18.715	45.0	-0.3	45.0	-0.3	323.3	1.000	14.60	0.990
10	16.520	17.252	45.8	0.8	45.8	0.8	322.8	1.005	14.91	0.969
11	16.111	16.904	47.0	2.4	47.0	2.4	325.0	1.002	15.32	0.935

RP	ABS VEL		REL VEL		MERID VEL		TANG VEL		WHEEL SPEED	
	IN	OUT	IN	OUT	IN	OUT	IN	OUT	IN	OUT
1	208.4	156.0	208.4	156.0	133.6	154.6	159.9	20.4	0.	0.
2	209.4	157.1	209.4	157.1	146.3	156.6	149.8	13.3	0.	0.
3	199.8	146.7	199.8	146.7	145.6	146.7	136.9	2.9	0.	0.
4	201.0	137.9	201.0	137.9	141.9	137.9	142.4	1.0	0.	0.
5	199.6	136.3	199.6	136.3	139.0	136.3	143.2	0.6	0.	0.
6	197.5	135.6	197.5	135.6	135.2	135.6	144.0	0.2	0.	0.
7	196.1	135.1	196.1	135.1	131.5	135.1	145.4	0.1	0.	0.
8	197.8	134.8	197.8	134.8	131.9	134.8	147.4	0.0	0.	0.
9	203.2	148.4	203.2	148.4	143.8	148.4	143.6	-0.7	0.	0.
10	221.9	159.3	221.9	159.3	154.6	159.2	159.2	2.2	0.	0.
11	235.8	158.1	235.8	158.1	160.8	158.0	172.4	6.6	0.	0.

RP	ABS MACH NO		REL MACH NO		MERID MACH NO		MERID PEAK SS	
	IN	OUT	IN	OUT	IN	OUT	VEL R	MACH NO
1	0.582	0.430	0.582	0.430	0.373	0.426	1.158	0.998
2	0.588	0.435	0.588	0.435	0.411	0.434	1.070	0.934
3	0.567	0.410	0.567	0.410	0.413	0.410	1.008	0.857
4	0.572	0.387	0.572	0.387	0.404	0.387	0.972	0.888
5	0.568	0.382	0.568	0.382	0.396	0.382	0.980	0.894
6	0.562	0.380	0.562	0.380	0.385	0.380	1.003	0.899
7	0.558	0.379	0.558	0.379	0.374	0.379	1.027	0.909
8	0.563	0.378	0.563	0.378	0.375	0.378	1.022	0.919
9	0.583	0.419	0.583	0.419	0.412	0.419	1.032	0.890
10	0.641	0.450	0.641	0.450	0.447	0.450	1.030	0.987
11	0.682	0.446	0.682	0.446	0.465	0.445	0.982	1.072

RP	PERCENT		INCIDENCE		DEV	D-FACT	EFF	LOSS COEFF		LOSS PARAM	
	SPAN	MEAN	SS	TOT				PROF	TOT	PROF	
1	5.00	13.3	7.2	18.6	0.474	0.	0.141	0.141	0.047	0.047	
2	10.00	10.4	4.3	15.0	0.462	0.	0.127	0.127	0.041	0.041	
3	30.00	9.3	3.2	10.1	0.468	0.	0.073	0.073	0.022	0.022	
4	42.50	10.8	4.7	9.1	0.515	0.	0.136	0.136	0.039	0.039	
5	45.00	11.4	5.3	8.9	0.519	0.	0.134	0.134	0.038	0.038	
6	47.50	12.2	6.1	8.7	0.517	0.	0.115	0.115	0.032	0.032	
7	50.00	13.1	7.0	8.7	0.516	0.	0.101	0.101	0.028	0.028	
8	52.50	13.3	7.2	8.6	0.522	0.	0.111	0.111	0.031	0.031	
9	70.00	8.7	2.7	7.9	0.448	0.	0.049	0.049	0.012	0.012	
10	90.00	6.9	1.0	8.9	0.442	0.	0.128	0.128	0.030	0.030	
11	95.00	7.1	1.1	10.5	0.483	0.	0.243	0.243	0.055	0.055	

TABLE VIII. - Continued. BLADE-ELEMENT DATA AT BLADE EDGES

FOR STATOR 8

(m) 70 Percent of design speed; reading 74

RP	RADII		ABS BETAM		REL BETAM		TOTAL TEMP		TOTAL PRESS	
	IN	OUT	IN	OUT	IN	OUT	IN	RATIO	IN	RATIO
1	23.945	23.947	20.5	7.0	20.5	7.0	309.6	1.000	12.33	0.900
2	23.505	23.538	20.2	3.9	20.2	3.9	308.4	1.000	12.38	0.931
3	21.742	21.902	20.8	1.2	20.8	1.2	307.1	0.998	12.46	0.933
4	20.635	20.884	23.4	-0.1	23.4	-0.1	307.4	0.999	12.47	0.944
5	20.414	20.681	24.7	-0.2	24.7	-0.2	307.9	0.999	12.51	0.945
6	20.193	20.480	26.0	-0.3	26.0	-0.3	309.0	0.997	12.50	0.951
7	19.972	20.279	27.1	-0.6	27.1	-0.6	309.4	0.996	12.51	0.951
8	19.751	20.079	27.0	-1.0	27.0	-1.0	308.8	0.998	12.57	0.945
9	18.219	18.715	27.9	-1.7	27.9	-1.7	308.9	1.000	12.79	0.950
10	16.520	17.252	33.4	3.1	33.4	3.1	311.9	1.004	13.26	0.904
11	16.111	16.904	36.2	8.0	36.2	8.0	313.9	1.002	13.48	0.840

RP	ABS VEL		REL VEL		MERID VEL		TANG VEL		WHEEL SPEED	
	IN	OUT	IN	OUT	IN	OUT	IN	OUT	IN	OUT
1	195.3	198.6	195.3	198.6	182.9	197.2	68.5	24.2	0.	0.
2	197.2	212.6	197.2	212.6	185.0	212.1	68.1	14.4	0.	0.
3	199.2	213.6	199.2	213.6	186.3	213.6	70.6	4.3	0.	0.
4	200.9	221.9	200.9	221.9	184.3	221.9	79.9	-0.4	0.	0.
5	202.4	224.6	202.4	224.6	183.9	224.6	84.5	-0.8	0.	0.
6	202.0	227.7	202.0	227.7	181.6	227.7	88.5	-1.0	0.	0.
7	202.7	229.0	202.7	229.0	180.4	229.0	92.4	-2.3	0.	0.
8	205.2	229.4	205.2	229.4	182.8	229.3	93.2	-3.9	0.	0.
9	214.4	249.7	214.4	249.7	189.6	249.5	100.2	-7.6	0.	0.
10	236.9	275.8	236.9	275.8	197.8	275.3	130.3	15.1	0.	0.
11	240.3	259.3	240.3	259.3	193.9	256.7	142.0	36.1	0.	0.

RP	ABS MACH NO		REL MACH NO		MERID MACH NO		MERID PEAK SS VEL R MACH NO	
	IN	OUT	IN	OUT	IN	OUT	IN	OUT
1	0.571	0.582	0.571	0.582	0.535	0.577	1.078	0.571
2	0.578	0.627	0.578	0.627	0.543	0.626	1.146	0.578
3	0.586	0.633	0.586	0.633	0.548	0.633	1.147	0.586
4	0.591	0.658	0.591	0.658	0.542	0.658	1.204	0.591
5	0.595	0.667	0.595	0.667	0.541	0.667	1.221	0.595
6	0.593	0.676	0.593	0.676	0.533	0.676	1.254	0.593
7	0.595	0.680	0.595	0.680	0.529	0.680	1.269	0.595
8	0.603	0.681	0.603	0.681	0.537	0.681	1.255	0.603
9	0.632	0.747	0.632	0.747	0.559	0.747	1.316	0.632
10	0.701	0.829	0.701	0.829	0.586	0.828	1.392	0.739
11	0.710	0.772	0.710	0.772	0.573	0.764	1.324	0.842

RP	PERCENT SPAN		INCIDENCE MEAN SS		DEV	D-FACT	EFF	LOSS COEFF		LOSS PARAM	
	SPAN	MEAN	SS	TOT				PROF	TOT	PROF	
1	5.00	-16.3	-22.4	18.0	0.058	0.	0.505	0.505	0.167	0.167	
2	10.00	-15.0	-21.2	14.1	0.011	0.	0.338	0.338	0.110	0.110	
3	30.00	-13.1	-19.3	10.1	0.028	0.	0.325	0.325	0.098	0.098	
4	42.50	-10.9	-17.0	8.6	0.010	0.	0.266	0.266	0.076	0.076	
5	45.00	-9.8	-15.9	8.5	0.009	0.	0.258	0.258	0.073	0.073	
6	47.50	-8.6	-14.7	8.4	-0.003	0.	0.231	0.231	0.065	0.065	
7	50.00	-7.6	-13.8	8.1	-0.001	0.	0.231	0.231	0.064	0.064	
8	52.50	-7.9	-14.0	7.7	0.011	0.	0.252	0.252	0.069	0.069	
9	70.00	-8.4	-14.5	6.5	-0.038	0.	0.214	0.214	0.054	0.054	
10	90.00	-5.6	-11.5	11.2	-0.055	0.	0.342	0.342	0.079	0.079	
11	95.00	-3.7	-9.6	16.0	0.016	0.	0.559	0.559	0.124	0.124	

TABLE VIII. - Continued. BLADE-ELEMENT DATA AT BLADE EDGES

FOR STATOR 8

(n) 70 Percent of design speed; reading 75

RP	RADII		ABS BETAM		REL BETAM		TOTAL TEMP		TOTAL PRESS	
	IN	OUT	IN	OUT	IN	OUT	IN	RATIO	IN	RATIO
1	23.945	23.947	24.6	6.5	24.6	6.5	312.4	0.999	12.65	0.939
2	23.505	23.538	24.1	4.6	24.1	4.6	310.4	1.001	12.68	0.962
3	21.742	21.902	24.3	-0.6	24.3	-0.6	308.9	0.999	12.71	0.973
4	20.635	20.884	26.5	-1.8	26.5	-1.8	309.1	0.999	12.71	0.974
5	20.414	20.681	27.4	-1.7	27.4	-1.7	309.4	0.999	12.76	0.972
6	20.193	20.480	28.5	-1.5	28.5	-1.5	310.2	0.997	12.74	0.977
7	19.972	20.279	29.7	-1.4	29.7	-1.4	310.5	0.996	12.73	0.980
8	19.751	20.079	29.4	-1.4	29.4	-1.4	310.1	0.998	12.78	0.976
9	18.219	18.715	30.3	-2.1	30.3	-2.1	310.2	0.998	12.94	0.973
10	16.520	17.252	35.5	-0.4	35.5	-0.4	312.4	1.004	13.34	0.977
11	16.111	16.904	38.3	2.0	38.3	2.0	314.4	1.004	13.60	0.944

RP	ABS VEL		REL VEL		MERID VEL		TANG VEL		WHEEL SPEED	
	IN	OUT	IN	OUT	IN	OUT	IN	OUT	IN	OUT
1	190.9	158.5	190.9	158.5	173.6	157.5	79.5	17.9	0.	0.
2	191.4	171.0	191.4	171.0	174.8	170.5	78.0	13.6	0.	0.
3	192.9	176.0	192.9	176.0	175.9	176.0	79.3	-1.8	0.	0.
4	195.1	178.8	195.1	178.8	174.5	178.8	87.1	-5.6	0.	0.
5	197.0	180.3	197.0	180.3	174.9	180.2	90.7	-5.2	0.	0.
6	196.3	181.8	196.3	181.8	172.5	181.8	93.8	-4.7	0.	0.
7	196.7	183.7	196.7	183.7	170.8	183.6	97.5	-4.4	0.	0.
8	199.0	184.4	199.0	184.4	173.4	184.4	97.7	-4.7	0.	0.
9	207.0	193.3	207.0	193.3	178.7	193.2	104.5	-7.0	0.	0.
10	227.0	223.2	227.0	223.2	184.7	223.2	132.0	-1.6	0.	0.
11	233.6	224.4	233.6	224.4	183.2	224.2	144.8	8.0	0.	0.

RP	ABS MACH NO		REL MACH NO		MERID MACH NO		MERID PEAK SS	
	IN	OUT	IN	OUT	IN	OUT	VEL R	MACH NO
1	0.555	0.457	0.555	0.457	0.505	0.454	0.907	0.555
2	0.559	0.496	0.559	0.496	0.510	0.494	0.975	0.559
3	0.565	0.513	0.565	0.513	0.515	0.513	1.001	0.565
4	0.571	0.521	0.571	0.521	0.511	0.521	1.024	0.571
5	0.577	0.526	0.577	0.526	0.512	0.525	1.031	0.577
6	0.574	0.530	0.574	0.530	0.504	0.530	1.054	0.574
7	0.575	0.536	0.575	0.536	0.499	0.535	1.075	0.575
8	0.583	0.538	0.583	0.538	0.508	0.538	1.063	0.583
9	0.608	0.566	0.608	0.566	0.525	0.565	1.081	0.608
10	0.669	0.655	0.669	0.655	0.544	0.655	1.209	0.779
11	0.687	0.657	0.687	0.657	0.539	0.656	1.224	0.872

RP	PERCENT SPAN	INCIDENCE		DEV	D-FACT	EFF	LOSS COEFF		LOSS PARAM	
		MEAN	SS				TOT	PROF	TOT	PROF
1	5.00	-12.2	-18.3	17.6	0.277	0.	0.322	0.322	0.106	0.106
2	10.00	-11.2	-17.3	14.8	0.216	0.	0.199	0.199	0.065	0.065
3	30.00	-9.6	-15.8	8.4	0.215	0.	0.137	0.137	0.041	0.041
4	42.50	-7.8	-13.9	6.9	0.219	0.	0.131	0.131	0.038	0.038
5	45.00	-7.0	-13.2	7.1	0.222	0.	0.138	0.138	0.039	0.039
6	47.50	-6.1	-12.2	7.2	0.214	0.	0.115	0.115	0.032	0.032
7	50.00	-5.0	-11.2	7.3	0.209	0.	0.099	0.099	0.028	0.028
8	52.50	-5.5	-11.6	7.2	0.214	0.	0.116	0.116	0.032	0.032
9	70.00	-6.0	-12.0	6.2	0.201	0.	0.124	0.124	0.032	0.032
10	90.00	-3.4	-9.3	7.7	0.150	0.	0.087	0.087	0.020	0.020
11	95.00	-1.6	-7.5	10.2	0.168	0.	0.207	0.207	0.047	0.047

TABLE VIII. - Continued. BLADE-ELEMENT DATA AT BLADE EDGES

FOR STATOR 8

(o) 70 Percent of design speed; reading 76

RP	RADII		ABS BETAM		REL BETAM		TOTAL TEMP		TOTAL PRESS	
	IN	OUT	IN	OUT	IN	OUT	IN	RATIO	IN	RATIO
1	23.945	23.947	30.6	5.8	30.6	5.8	316.7	0.998	13.13	0.956
2	23.505	23.538	29.3	4.4	29.3	4.4	314.5	0.999	13.12	0.973
3	21.742	21.902	29.1	-0.6	29.1	-0.6	311.7	1.000	13.04	0.983
4	20.635	20.884	30.8	-1.5	30.8	-1.5	311.6	0.999	13.04	0.980
5	20.414	20.681	31.4	-1.3	31.4	-1.3	311.7	0.998	13.07	0.978
6	20.193	20.480	32.5	-1.2	32.5	-1.2	312.2	0.998	13.03	0.982
7	19.972	20.279	33.8	-1.1	33.8	-1.1	312.5	0.997	13.01	0.985
8	19.751	20.079	33.7	-1.1	33.7	-1.1	311.7	0.999	13.02	0.984
9	18.219	18.715	33.9	-1.9	33.9	-1.9	311.7	0.998	13.17	0.976
10	16.520	17.252	37.6	-0.3	37.6	-0.3	313.6	1.004	13.47	0.980
11	16.111	16.904	41.3	1.9	41.3	1.9	315.4	1.003	13.77	0.949

RP	ABS VEL		REL VEL		MERID VEL		TANG VEL		WHEEL SPEED	
	IN	OUT	IN	OUT	IN	OUT	IN	OUT	IN	OUT
1	186.6	147.4	186.6	147.4	160.6	146.7	95.0	14.8	0.	0.
2	187.0	156.3	187.0	156.3	163.1	155.8	91.5	12.0	0.	0.
3	184.7	158.0	184.7	158.0	161.4	158.0	89.8	-1.6	0.	0.
4	187.3	158.4	187.3	158.4	160.9	158.3	96.0	-4.1	0.	0.
5	188.9	159.1	188.9	159.1	161.2	159.1	98.3	-3.5	0.	0.
6	187.9	160.4	187.9	160.4	158.4	160.4	101.1	-3.2	0.	0.
7	187.6	161.7	187.6	161.7	155.9	161.6	104.4	-3.1	0.	0.
8	188.3	162.1	188.3	162.1	156.6	162.1	104.6	-3.1	0.	0.
9	198.1	168.8	198.1	168.8	164.4	168.7	110.6	-5.6	0.	0.
10	216.1	193.4	216.1	193.4	171.2	193.4	131.8	-1.0	0.	0.
11	224.6	195.2	224.6	195.2	168.8	195.0	148.1	6.6	0.	0.

RP	ABS MACH NO		REL MACH NO		MERID MACH NO		MERID PEAK SS	
	IN	OUT	IN	OUT	IN	OUT	VEL R	MACH NO
1	0.538	0.421	0.538	0.421	0.463	0.419	0.913	0.538
2	0.541	0.448	0.541	0.448	0.472	0.447	0.955	0.541
3	0.537	0.456	0.537	0.456	0.469	0.456	0.979	0.537
4	0.545	0.457	0.545	0.457	0.468	0.457	0.984	0.545
5	0.549	0.459	0.549	0.459	0.469	0.459	0.987	0.549
6	0.546	0.463	0.546	0.463	0.460	0.463	1.013	0.576
7	0.545	0.467	0.545	0.467	0.453	0.467	1.037	0.608
8	0.548	0.468	0.548	0.468	0.455	0.468	1.035	0.604
9	0.578	0.489	0.578	0.489	0.480	0.488	1.026	0.646
10	0.633	0.561	0.633	0.561	0.501	0.561	1.130	0.790
11	0.657	0.564	0.657	0.564	0.494	0.564	1.156	0.904

RP	PERCENT		INCIDENCE		DEV	D-FACT	EFF	LOSS COEFF.		LOSS PARAM	
	SPAN	MEAN	SS	TOT				PROF	TOT	PROF	
1	5.00	-6.2	-12.3	16.8	0.353	0.	0.246	0.246	0.081	0.081	
2	10.00	-5.9	-12.1	14.6	0.303	0.	0.152	0.152	0.049	0.049	
3	30.00	-4.8	-11.0	8.4	0.294	0.	0.094	0.094	0.028	0.028	
4	42.50	-3.5	-9.6	7.3	0.307	0.	0.112	0.112	0.032	0.032	
5	45.00	-3.1	-9.2	7.4	0.310	0.	0.121	0.121	0.034	0.034	
6	47.50	-2.0	-8.2	7.5	0.301	0.	0.096	0.096	0.027	0.027	
7	50.00	-0.9	-7.1	7.6	0.297	0.	0.084	0.084	0.023	0.023	
8	52.50	-1.2	-7.3	7.5	0.295	0.	0.088	0.088	0.024	0.024	
9	70.00	-2.3	-8.4	6.3	0.296	0.	0.119	0.119	0.030	0.030	
10	90.00	-1.3	-7.3	7.8	0.243	0.	0.085	0.085	0.020	0.020	
11	95.00	1.3	-4.6	10.1	0.269	0.	0.202	0.202	0.045	0.045	

TABLE VIII. - Continued. BLADE-ELEMENT DATA AT BLADE EDGES

FOR STATOR 8

(p) 70 Percent of design speed; reading 77

RP	RADII		ABS BETAM		REL BETAM		TOTAL TEMP		TOTAL PRESS	
	IN	OUT	IN	OUT	IN	OUT	IN	RATIO	IN	RATIO
1	23.945	23.947	37.9	5.4	37.9	5.4	321.8	0.998	13.50	0.969
2	23.505	23.538	36.5	4.6	36.5	4.6	319.1	1.000	13.54	0.981
3	21.742	21.902	35.9	0.3	35.9	0.3	315.3	0.999	13.39	0.981
4	20.635	20.884	36.7	0.4	36.7	0.4	315.1	0.997	13.41	0.976
5	20.414	20.681	37.2	0.3	37.2	0.3	315.1	0.996	13.37	0.977
6	20.193	20.480	39.8	0.2	39.8	0.2	314.7	0.997	13.27	0.985
7	19.972	20.279	39.8	0.2	39.8	0.2	314.7	0.997	13.28	0.984
8	19.751	20.079	39.8	0.2	39.8	0.2	314.4	0.998	13.26	0.986
9	18.219	18.715	39.2	-0.7	39.2	-0.7	314.0	0.997	13.40	0.976
10	16.520	17.252	42.7	0.3	42.7	0.3	314.2	1.004	13.56	0.981
11	16.111	16.904	44.3	3.0	44.3	-3.0	316.1	1.002	13.89	0.946

RP	ABS VEL		REL VEL		MERID VEL		TANG VEL		WHEEL SPEED	
	IN	OUT	IN	OUT	IN	OUT	IN	OUT	IN	OUT
1	181.2	137.5	181.2	137.5	143.0	136.9	111.3	12.8	0.	0.
2	182.6	145.7	182.6	145.7	146.7	145.2	108.7	11.7	0.	0.
3	178.7	139.3	178.7	139.3	144.8	139.3	104.7	0.6	0.	0.
4	182.9	139.3	182.9	139.3	146.5	139.3	109.4	0.9	0.	0.
5	181.9	139.1	181.9	139.1	144.8	139.1	110.0	0.8	0.	0.
6	179.0	139.8	179.0	139.8	137.4	139.8	114.7	0.4	0.	0.
7	179.2	139.9	179.2	139.9	137.6	139.9	114.7	0.6	0.	0.
8	179.0	140.7	179.0	140.7	137.6	140.7	114.5	0.4	0.	0.
9	189.8	146.1	189.8	146.1	147.1	146.1	119.9	-1.7	0.	0.
10	202.8	166.0	202.8	166.0	149.0	166.0	137.7	0.8	0.	0.
11	214.8	163.9	214.8	163.9	153.7	163.7	150.0	8.5	0.	0.

RP	ABS MACH NO		REL MACH NO		MERID MACH NO		MERID PEAK SS VEL R MACH NO	
	IN	OUT	IN	OUT	IN	OUT		
1	0.517	0.388	0.517	0.388	0.408	0.387	0.957	0.670
2	0.524	0.414	0.524	0.414	0.421	0.412	0.989	0.666
3	0.515	0.398	0.515	0.398	0.417	0.398	0.963	0.645
4	0.528	0.398	0.528	0.398	0.423	0.398	0.951	0.665
5	0.525	0.398	0.525	0.398	0.418	0.398	0.960	0.668
6	0.517	0.400	0.517	0.400	0.397	0.400	1.017	0.733
7	0.517	0.400	0.517	0.400	0.397	0.400	1.016	0.730
8	0.517	0.403	0.517	0.403	0.397	0.403	1.022	0.695
9	0.550	0.419	0.550	0.419	0.427	0.419	0.993	0.731
10	0.590	0.477	0.590	0.477	0.434	0.477	1.115	0.846
11	0.626	0.469	0.626	0.469	0.448	0.469	1.065	0.926

RP	PERCENT	INCIDENCE		DEV	D-FACT	EFF	LOSS COEFF		LOSS PARAM	
	SPAN	MEAN	SS				TOT	PROF	TOT	PROF
1	5.00	1.1	-5.0	16.4	0.422	0.	0.186	0.186	0.062	0.062
2	10.00	1.3	-4.8	14.8	0.376	0.	0.114	0.114	0.037	0.037
3	30.00	2.0	-4.2	9.2	0.396	0.	0.113	0.113	0.034	0.034
4	42.50	2.4	-3.7	9.1	0.408	0.	0.140	0.140	0.040	0.040
5	45.00	2.8	-3.3	9.0	0.405	0.	0.134	0.134	0.038	0.038
6	47.50	5.3	-0.9	8.8	0.397	0.	0.090	0.090	0.025	0.025
7	50.00	5.1	-1.0	8.9	0.395	0.	0.098	0.098	0.027	0.027
8	52.50	4.9	-1.3	8.8	0.388	0.	0.087	0.087	0.024	0.024
9	70.00	2.9	-3.1	7.5	0.391	0.	0.131	0.131	0.033	0.033
10	90.00	3.8	-2.1	8.4	0.334	0.	0.090	0.090	0.021	0.021
11	95.00	4.4	-1.5	11.1	0.381	0.	0.231	0.231	0.052	0.052

TABLE VIII. - Continued. BLADE-ELEMENT DATA AT BLADE EDGES

FOR STATOR 8.

(q) 70 Percent of design speed; reading 78

RP	RADII		ABS BETAM		REL BETAM		TOTAL TEMP		TOTAL PRESS	
	IN	OUT	IN	OUT	IN	OUT	IN	RATIO	IN	RATIO
1	23.945	23.947	51.4	8.2	51.4	8.2	328.4	0.994	13.75	0.966
2	23.505	23.538	47.8	5.4	47.8	5.4	325.2	0.996	13.70	0.970
3	21.742	21.902	42.4	1.0	42.4	1.0	318.2	0.999	13.55	0.981
4	20.635	20.884	42.1	0.9	42.1	0.9	317.2	0.996	13.56	0.972
5	20.414	20.681	42.3	0.5	42.3	0.5	316.9	0.997	13.49	0.975
6	20.193	20.480	43.0	0.3	43.0	0.3	316.8	0.996	13.42	0.978
7	19.972	20.279	44.4	0.3	44.4	0.3	316.6	0.996	13.39	0.979
8	19.751	20.079	44.8	0.3	44.8	0.3	316.4	0.996	13.41	0.977
9	18.219	18.715	44.1	0.1	44.1	0.1	315.4	0.997	13.53	0.975
10	16.520	17.252	44.5	0.9	44.5	0.9	314.7	1.004	13.66	0.973
11	16.111	16.904	46.0	2.9	46.0	2.9	316.4	1.002	13.95	0.947

RP	ABS VEL		REL VEL		MERID VEL		TANG VEL		WHEEL SPEED	
	IN	OUT	IN	OUT	IN	OUT	IN	OUT	IN	OUT
1	179.1	126.2	179.1	126.2	111.8	124.9	139.9	18.0	0.	0.
2	177.4	126.7	177.4	126.7	119.1	126.1	131.5	11.9	0.	0.
3	174.3	126.3	174.3	126.3	128.7	126.3	117.6	2.1	0.	0.
4	177.7	122.6	177.7	122.6	131.9	122.6	119.1	1.9	0.	0.
5	175.4	121.3	175.4	121.3	129.8	121.3	118.0	1.2	0.	0.
6	173.8	120.5	173.8	120.5	127.2	120.5	118.5	0.7	0.	0.
7	173.2	119.9	173.2	119.9	123.8	119.9	121.2	0.6	0.	0.
8	174.9	119.8	174.9	119.8	124.2	119.8	123.1	0.6	0.	0.
9	184.6	129.7	184.6	129.7	132.5	129.7	128.5	0.2	0.	0.
10	197.8	145.2	197.8	145.2	141.0	145.1	138.7	2.2	0.	0.
11	209.1	144.3	209.1	144.3	145.4	144.1	150.4	7.3	0.	0.

RP	ABS MACH NO		REL MACH NO		MERID MACH NO		MERID PEAK SS	
	IN	OUT	IN	OUT	IN	OUT	VEL R	MACH NO
1	0.505	0.353	0.505	0.353	0.315	0.349	1.118	0.889
2	0.503	0.356	0.503	0.356	0.338	0.354	1.059	0.836
3	0.500	0.358	0.500	0.358	0.369	0.358	0.982	0.741
4	0.510	0.348	0.510	0.348	0.379	0.348	0.930	0.740
5	0.504	0.345	0.504	0.345	0.373	0.345	0.935	0.731
6	0.499	0.342	0.499	0.342	0.365	0.342	0.948	0.734
7	0.498	0.341	0.498	0.341	0.356	0.341	0.968	0.752
8	0.503	0.340	0.503	0.340	0.357	0.340	0.964	0.763
9	0.533	0.370	0.533	0.370	0.383	0.370	0.979	0.799
10	0.574	0.414	0.574	0.414	0.409	0.414	1.029	0.858
11	0.608	0.411	0.608	0.411	0.422	0.411	0.991	0.934

RP	PERCENT		INCIDENCE		DEV	D-FACT	EFF	LOSS COEFF		LOSS PARAM	
	SPAN	MEAN	SS	SS				TOT	PROF	TOT	PROF
1	5.00	14.6	8.5	19.3	0.521	0.	0.213	0.213	0.070	0.070	
2	10.00	12.6	6.5	15.6	0.506	0.	0.187	0.187	0.061	0.061	
3	30.00	8.5	2.4	10.0	0.475	0.	0.119	0.119	0.036	0.036	
4	42.50	7.8	1.7	9.6	0.498	0.	0.171	0.171	0.049	0.049	
5	45.00	7.8	1.7	9.2	0.496	0.	0.158	0.158	0.045	0.045	
6	47.50	8.4	2.3	9.0	0.496	0.	0.141	0.141	0.040	0.040	
7	50.00	9.7	3.5	8.9	0.500	0.	0.136	0.136	0.038	0.038	
8	52.50	9.8	3.7	8.9	0.507	0.	0.147	0.147	0.040	0.040	
9	70.00	7.9	1.8	8.3	0.472	0.	0.144	0.144	0.037	0.037	
10	90.00	5.6	-0.3	9.0	0.422	0.	0.133	0.133	0.031	0.031	
11	95.00	6.0	0.1	11.0	0.460	0.	0.240	0.240	0.054	0.054	

TABLE VIII. - Continued. BLADE-ELEMENT DATA AT BLADE EDGES

FOR STATOR 8

(r) 60 Percent of design speed; reading 82

RP	RADII		ABS BETAM		REL BETAM		TOTAL TEMP		TOTAL PRESS	
	IN	OUT	IN	OUT	IN	OUT	IN	RATIO	IN	RATIO
1	23.945	23.947	53.8	8.0	53.8	8.0	318.6	0.993	12.76	0.973
2	23.505	23.538	47.9	5.3	47.9	5.3	315.7	0.996	12.67	0.982
3	21.742	21.902	40.4	0.5	40.4	0.5	310.3	0.999	12.58	0.990
4	20.635	20.884	42.3	0.7	42.3	0.7	309.3	0.998	12.53	0.987
5	20.414	20.681	43.3	0.3	43.3	0.3	309.2	0.998	12.48	0.989
6	20.193	20.480	44.1	0.0	44.1	0.0	309.2	0.998	12.45	0.990
7	19.972	20.279	45.5	-0.2	45.5	-0.2	308.8	0.998	12.41	0.991
8	19.751	20.079	46.0	-0.2	46.0	-0.2	308.3	0.998	12.41	0.991
9	18.219	18.715	43.5	-0.6	43.5	-0.6	307.9	0.999	12.47	0.990
10	16.520	17.252	43.8	0.7	43.8	0.7	307.8	1.002	12.66	0.982
11	16.111	16.904	45.6	2.8	45.6	2.8	308.8	1.001	12.81	0.965

RP	ABS VEL		REL VEL		MERID VEL		TANG VEL		WHEEL SPEED	
	IN	OUT	IN	OUT	IN	OUT	IN	OUT	IN	OUT
1	154.1	110.4	154.1	110.4	91.0	109.4	124.4	15.3	0.	0.
2	151.1	111.6	151.1	111.6	101.3	111.1	112.1	10.3	0.	0.
3	149.7	112.2	149.7	112.2	114.0	112.2	97.0	1.0	0.	0.
4	150.2	108.9	150.2	108.9	111.0	108.9	101.2	1.3	0.	0.
5	148.3	107.7	148.3	107.7	108.0	107.7	101.6	0.6	0.	0.
6	146.9	106.7	146.9	106.7	105.5	106.7	102.3	0.1	0.	0.
7	145.9	106.0	145.9	106.0	102.2	106.0	104.1	-0.3	0.	0.
8	146.4	105.7	146.4	105.7	101.6	105.7	105.3	-0.3	0.	0.
9	154.6	113.4	154.6	113.4	112.3	113.4	106.3	-1.1	0.	0.
10	170.2	125.8	170.2	125.8	122.9	125.8	117.7	1.5	0.	0.
11	178.6	125.0	178.6	125.0	124.9	124.8	127.7	6.1	0.	0.

RP	ABS MACH NO		REL MACH NO		MERID MACH NO.		MERID PEAK SS	
	IN	OUT	IN	OUT	IN	OUT	VEL R	MACH NO
1	0.439	0.313	0.439	0.313	0.259	0.310	1.222	0.809
2	0.432	0.317	0.432	0.317	0.290	0.316	1.096	0.719
3	0.432	0.321	0.432	0.321	0.329	0.321	0.985	0.610
4	0.434	0.312	0.434	0.312	0.321	0.312	0.981	0.633
5	0.428	0.309	0.428	0.309	0.312	0.309	0.997	0.636
6	0.424	0.306	0.424	0.306	0.305	0.306	1.011	0.640
7	0.421	0.304	0.421	0.304	0.295	0.304	1.037	0.653
8	0.423	0.303	0.423	0.303	0.294	0.303	1.040	0.660
9	0.448	0.326	0.448	0.326	0.326	0.326	1.010	0.662
10	0.496	0.362	0.496	0.362	0.358	0.362	1.024	0.728
11	0.521	0.359	0.521	0.359	0.364	0.359	0.999	0.794

RP	PERCENT SPAN	INCIDENCE		DEV	D-FACT	EFF	LOSS COEFF		LOSS PARAM.	
		MEAN	SS				TOT	PROF	TOT	PROF
1	5.00	17.0	10.9	19.0	0.518	0.	0.214	0.214	0.071	0.071
2	10.00	12.7	6.5	15.5	0.482	0.	0.153	0.153	0.050	0.050
3	30.00	6.5	0.4	9.5	0.444	0.	0.081	0.081	0.024	0.024
4	42.50	8.1	1.9	9.4	0.465	0.	0.108	0.108	0.031	0.031
5	45.00	8.8	2.7	9.0	0.467	0.	0.094	0.094	0.027	0.027
6	47.50	9.6	3.4	8.7	0.469	0.	0.087	0.087	0.024	0.024
7	50.00	10.8	4.7	8.5	0.471	0.	0.074	0.074	0.021	0.021
8	52.50	11.1	5.0	8.4	0.475	0.	0.080	0.080	0.022	0.022
9	70.00	7.2	1.1	7.7	0.441	0.	0.079	0.079	0.020	0.020
10	90.00	4.8	-1.1	8.8	0.415	0.	0.119	0.119	0.027	0.027
11	95.00	5.7	-0.2	10.9	0.449	0.	0.210	0.210	0.047	0.047

TABLE VIII. - Concluded. BLADE-ELEMENT DATA AT BLADE EDGES
FOR STATOR 8

(s) 50 Percent of design speed; reading 83

RP	RADII		ABS BETAM		REL BETAM		TOTAL TEMP		TOTAL PRESS	
	IN	OUT	IN	OUT	IN	OUT	IN	RATIO	IN	RATIO
1	23.945	23.947	53.1	8.1	53.1	8.1	308.9	0.997	11.89	0.983
2	23.505	23.538	46.8	5.2	46.8	5.2	307.2	0.998	11.86	0.985
3	21.742	21.902	40.5	0.4	40.5	0.4	303.3	1.001	11.78	0.993
4	20.635	20.884	42.5	0.9	42.5	0.9	302.8	0.999	11.77	0.989
5	20.414	20.681	43.4	0.7	43.4	0.7	302.9	0.999	11.76	0.988
6	20.193	20.480	44.3	0.2	44.3	0.2	302.6	0.999	11.72	0.990
7	19.972	20.279	45.7	-0.0	45.7	-0.0	302.4	0.998	11.70	0.991
8	19.751	20.079	46.2	-0.1	46.2	-0.1	302.6	0.998	11.69	0.992
9	18.219	18.715	43.9	-0.6	43.9	-0.6	301.6	1.001	11.69	0.995
10	16.520	17.252	43.3	0.4	43.3	0.4	301.7	1.003	11.83	0.990
11	16.111	16.904	45.6	2.8	45.6	2.8	302.6	1.002	11.96	0.975

RP	ABS VEL		REL VEL		MERID VEL		TANG VEL		WHEEL SPEED	
	IN	OUT	IN	OUT	IN	OUT	IN	OUT	IN	OUT
1	127.2	92.6	127.2	92.6	76.3	91.6	101.8	13.0	0.	0.
2	126.2	93.1	126.2	93.1	86.4	92.7	92.0	8.4	0.	0.
3	123.8	93.1	123.8	93.1	94.1	93.1	80.5	0.6	0.	0.
4	125.8	91.0	125.8	91.0	92.7	91.0	85.0	1.5	0.	0.
5	125.3	89.8	125.3	89.8	91.1	89.8	86.1	1.1	0.	0.
6	123.8	89.0	123.8	89.0	88.6	89.0	86.4	0.3	0.	0.
7	122.9	88.4	122.9	88.4	85.8	88.4	88.0	-0.0	0.	0.
8	122.8	88.6	122.8	88.6	85.0	88.6	88.7	-0.1	0.	0.
9	127.2	95.5	127.2	95.5	91.7	95.5	88.2	-1.0	0.	0.
10	140.8	106.9	140.8	106.9	102.5	106.9	96.6	0.7	0.	0.
11	149.4	106.3	149.4	106.3	104.5	106.2	106.8	5.1	0.	0.

RP	ABS MACH NO		REL MACH NO		MERID MACH NO		MERID PEAK SS	
	IN	OUT	IN	OUT	IN	OUT	VEL R	MACH NO
1	0.366	0.265	0.366	0.265	0.220	0.262	1.201	0.666
2	0.364	0.267	0.364	0.267	0.249	0.266	1.073	0.592
3	0.359	0.268	0.359	0.268	0.273	0.268	0.989	0.510
4	0.365	0.263	0.365	0.263	0.269	0.263	0.982	0.535
5	0.364	0.259	0.364	0.259	0.264	0.259	0.986	0.542
6	0.359	0.257	0.359	0.257	0.257	0.257	1.005	0.544
7	0.357	0.255	0.357	0.255	0.249	0.255	1.030	0.556
8	0.357	0.256	0.357	0.256	0.247	0.256	1.043	0.559
9	0.371	0.276	0.371	0.276	0.267	0.276	1.041	0.553
10	0.411	0.310	0.411	0.310	0.299	0.310	1.043	0.598
11	0.437	0.307	0.437	0.307	0.305	0.307	1.016	0.666

RP	PERCENT SPAN		INCIDENCE MEAN SS		DEV	D-FACT	EFF	LOSS COEFF		LOSS PARAM	
	SPAN	MEAN	SS	TOT				PROF	TOT	PROF	
1	5.00	16.3	10.2	19.1	0.504	0.	0.197	0.197	0.065	0.065	
2	10.00	11.6	5.4	15.4	0.479	0.	0.166	0.166	0.054	0.054	
3	30.00	6.6	0.5	9.4	0.443	0.	0.082	0.082	0.025	0.025	
4	42.50	8.2	2.1	9.6	0.466	0.	0.125	0.125	0.036	0.036	
5	45.00	9.0	2.8	9.4	0.475	0.	0.132	0.132	0.038	0.038	
6	47.50	9.7	3.6	8.9	0.475	0.	0.114	0.114	0.032	0.032	
7	50.00	11.0	4.9	8.6	0.479	0.	0.104	0.104	0.029	0.029	
8	52.50	11.3	5.2	8.5	0.476	0.	0.094	0.094	0.026	0.026	
9	70.00	7.6	1.6	7.6	0.425	0.	0.051	0.051	0.013	0.013	
10	90.00	4.4	-1.6	8.5	0.394	0.	0.089	0.089	0.021	0.021	
11	95.00	5.7	-0.2	10.9	0.437	0.	0.203	0.203	0.046	0.046	

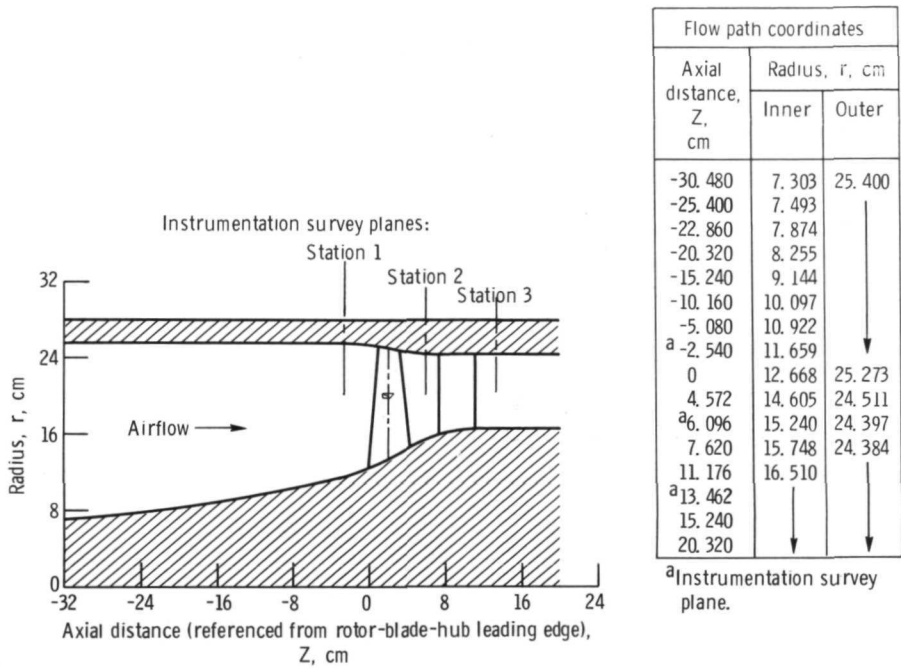
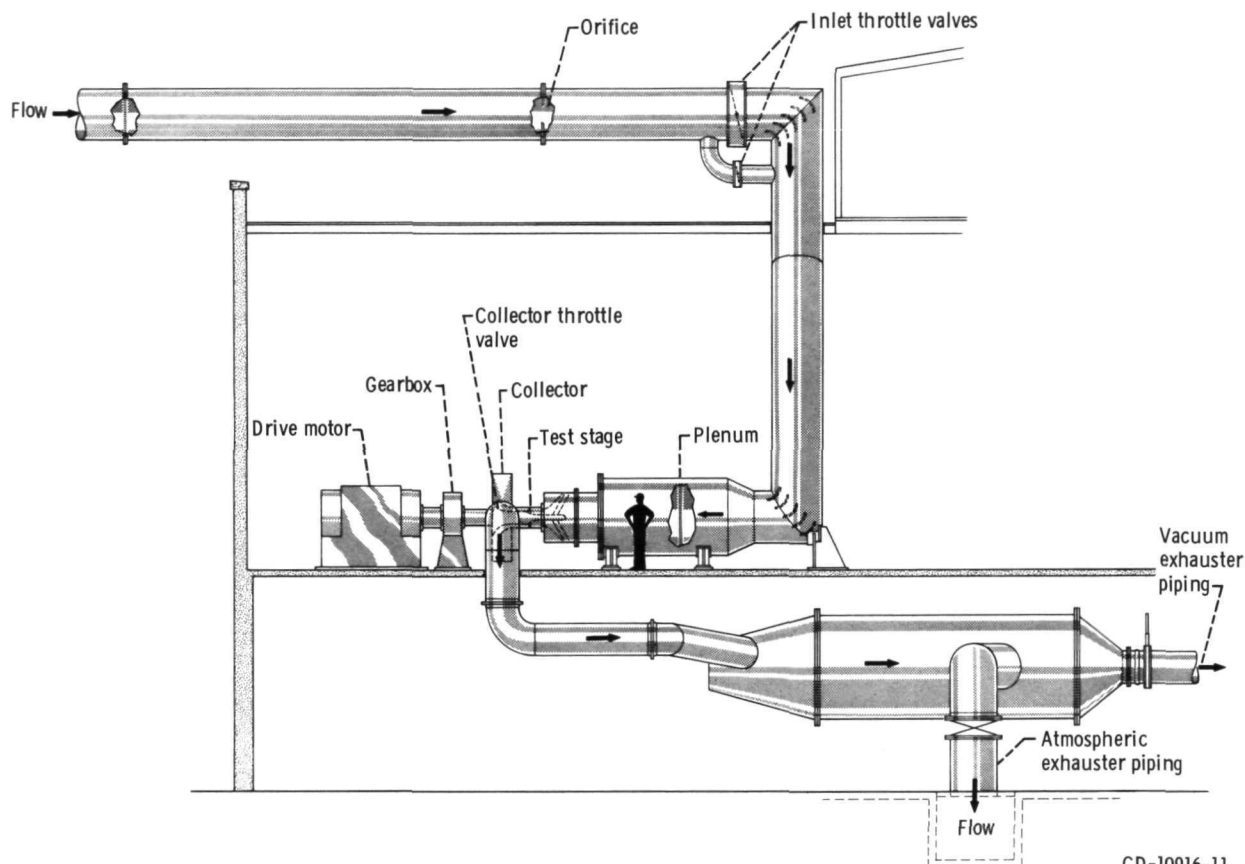

Figure 1. - Flow path for stage 8-8, showing axial location of instrumentation.



CD-10916-11

Figure 2 - Compressor test facility.

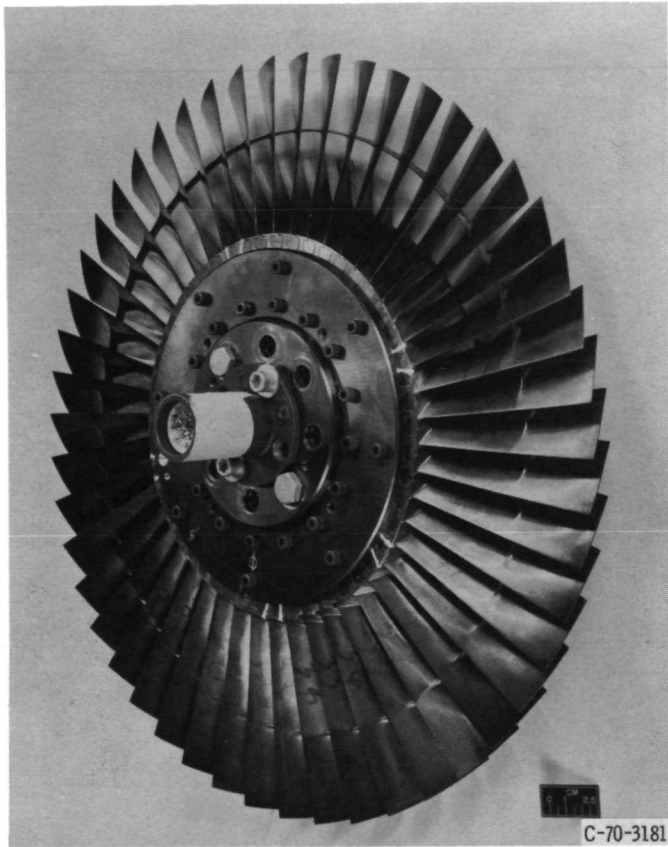

Figure 3. - Rotor 8.

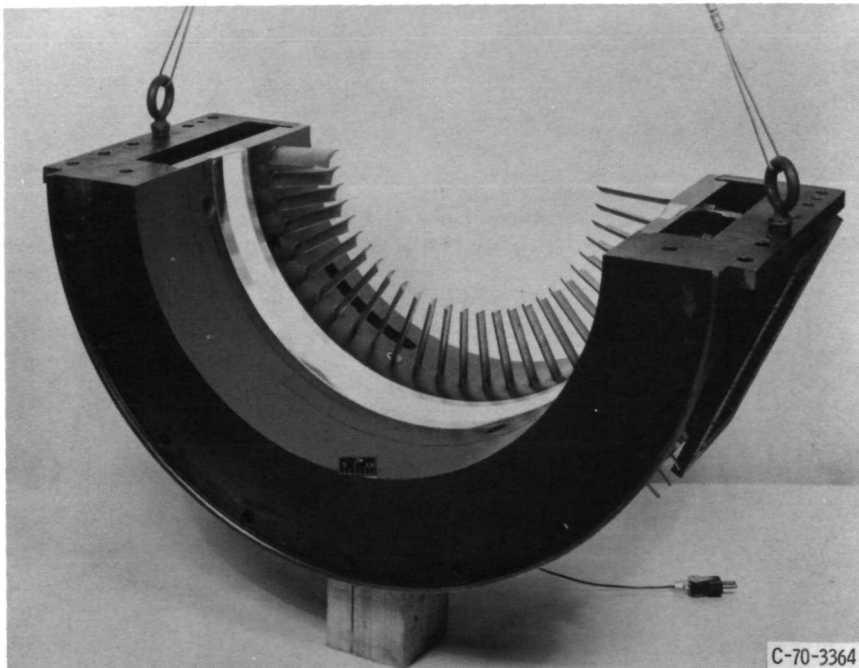
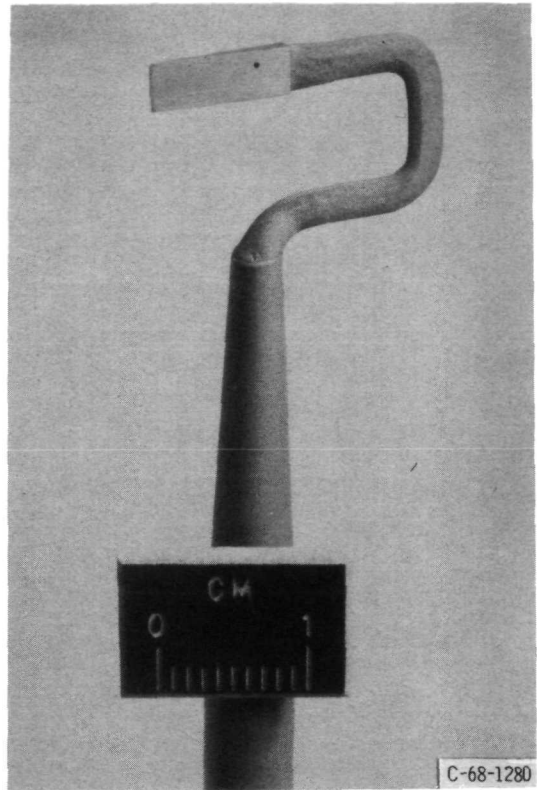
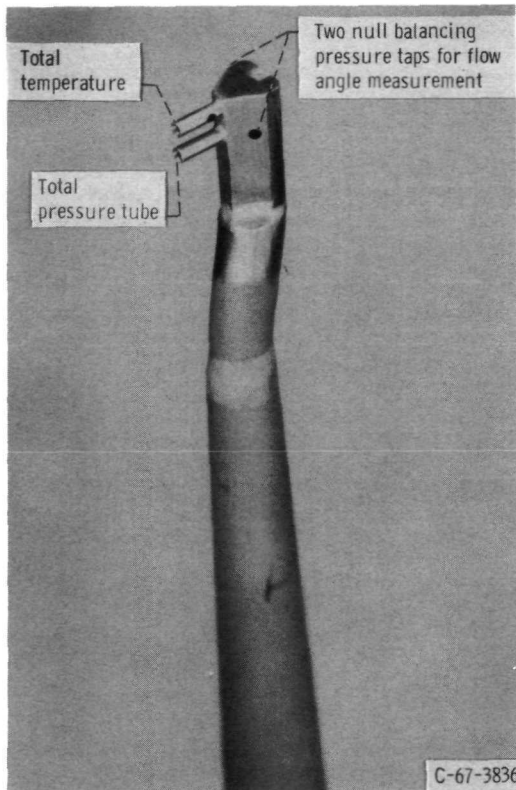

Figure 4. - Stator 8.



(a) Combination total pressure, total temperature, and flow angle probe (double barrel probe).

(b) Static pressure probe (8° wedge).

Figure 5. - Sensing probes.

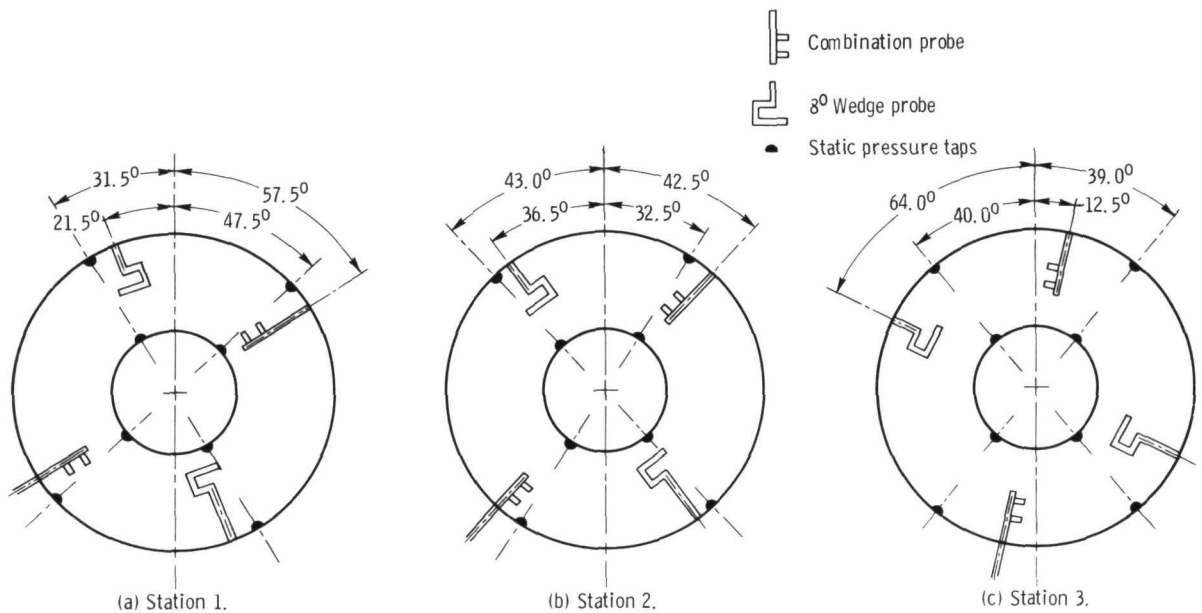

CD-11335-14

Figure 6. - Circumferential location of instrumentation at measuring stations - facing downstream.

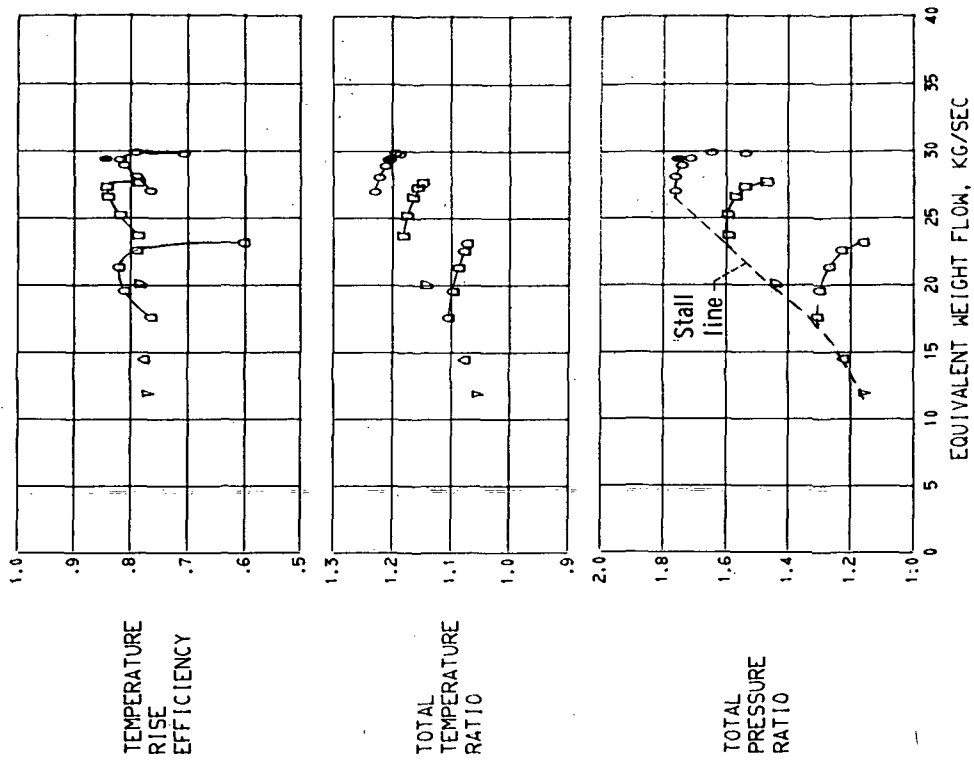

FIGURE 8. - OVERALL PERFORMANCE FOR STAGE 8-8.

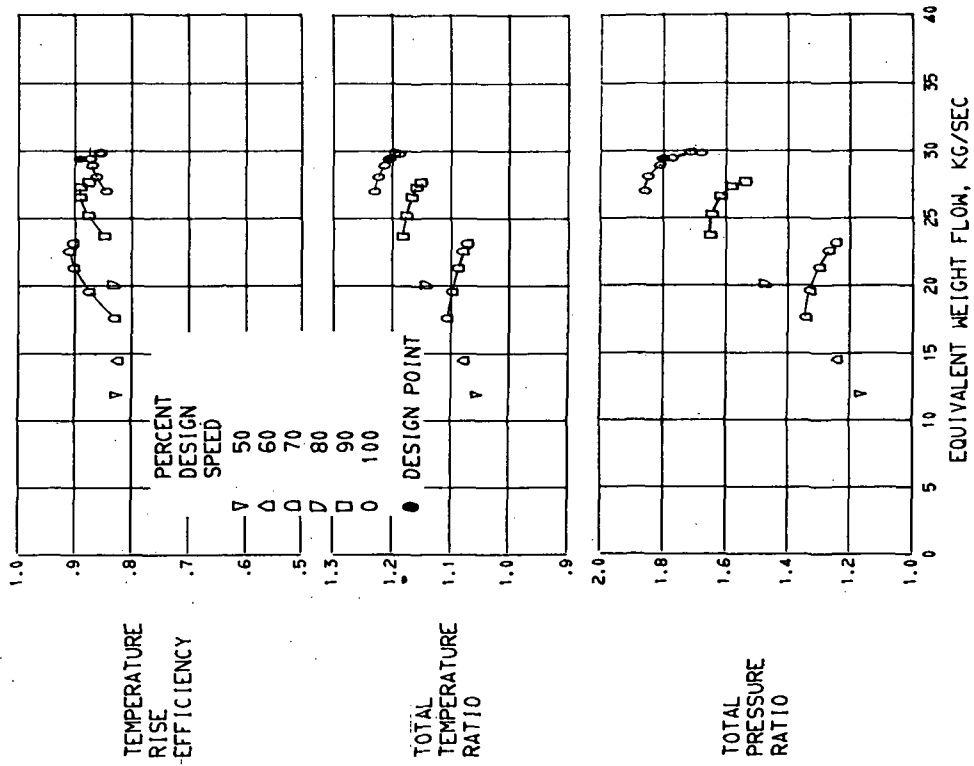
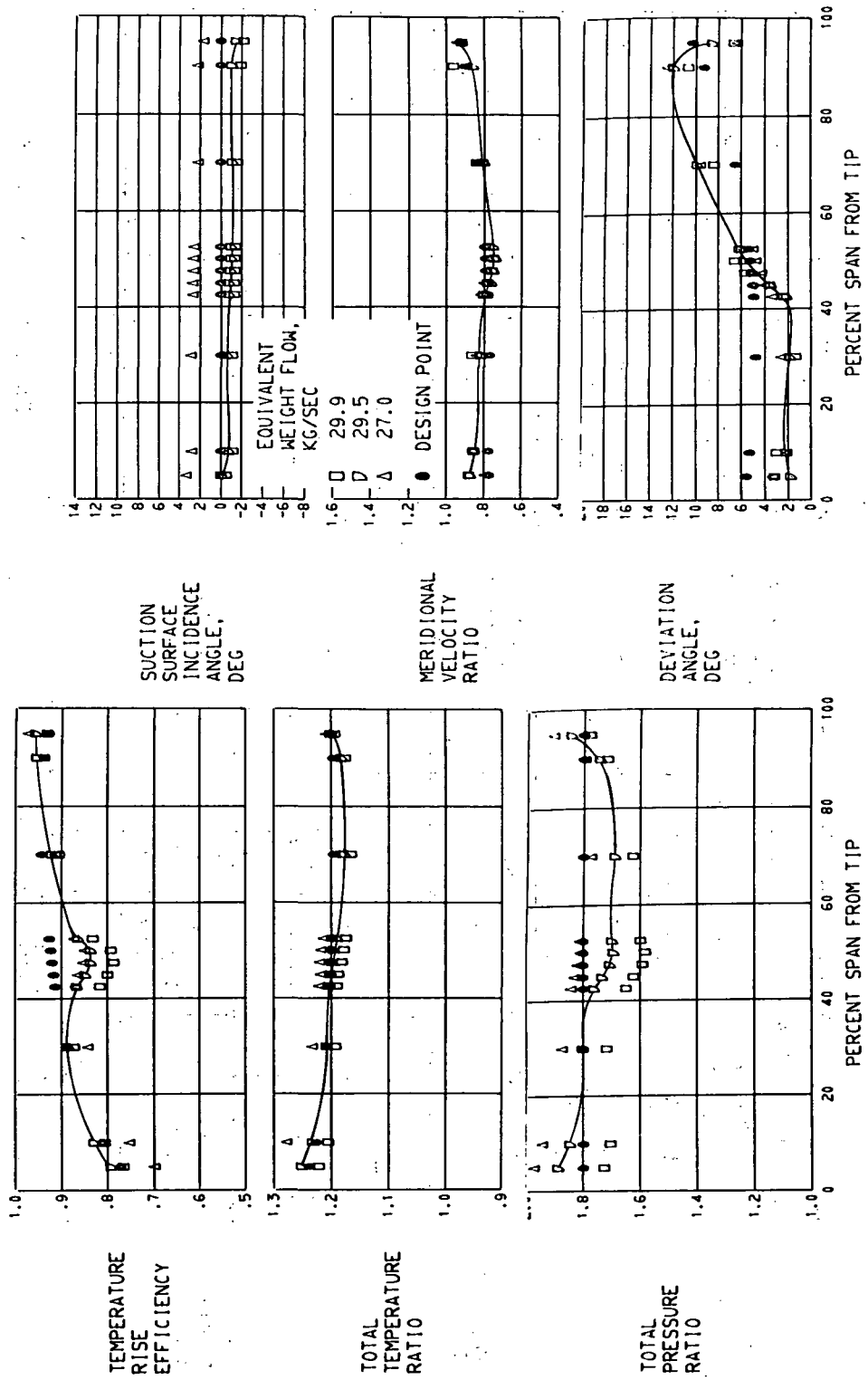

FIGURE 7. - OVERALL PERFORMANCE FOR ROTOR 8.



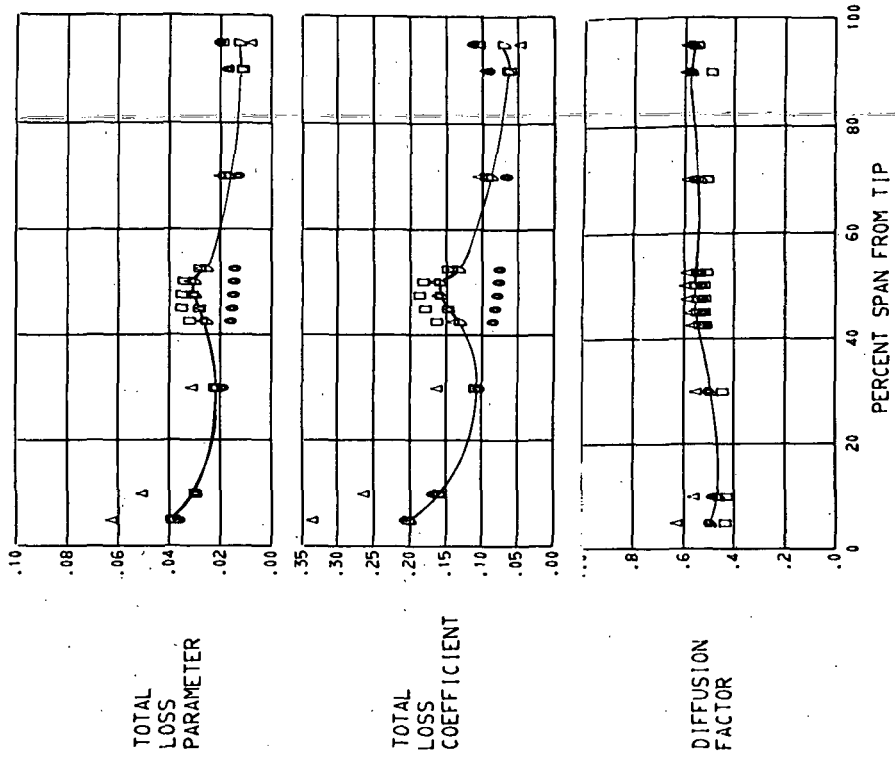

FIGURE 9. - RADIAL DISTRIBUTION OF PERFORMANCE FOR ROTOR 8. 100 PERCENT DESIGN SPEED.

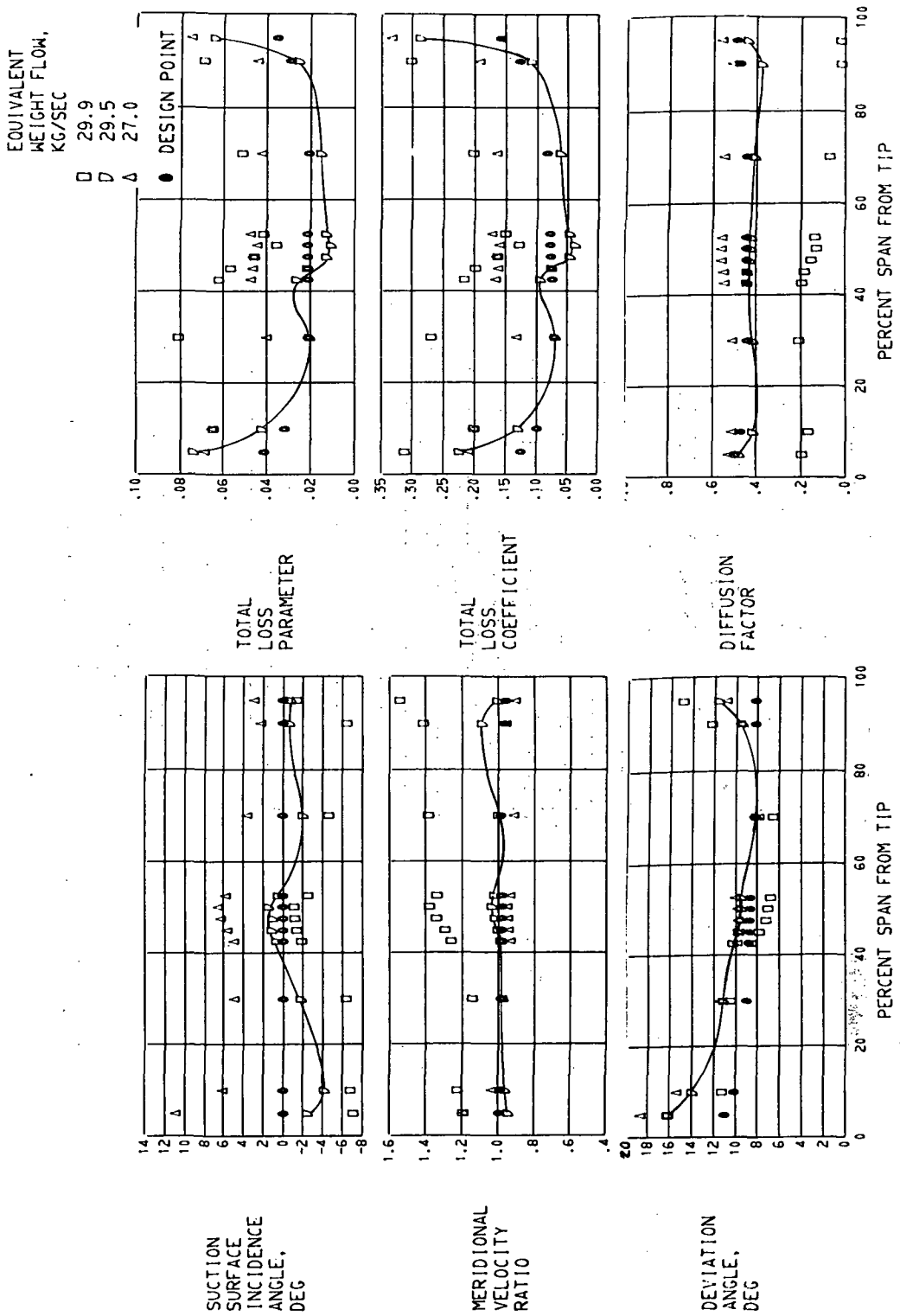
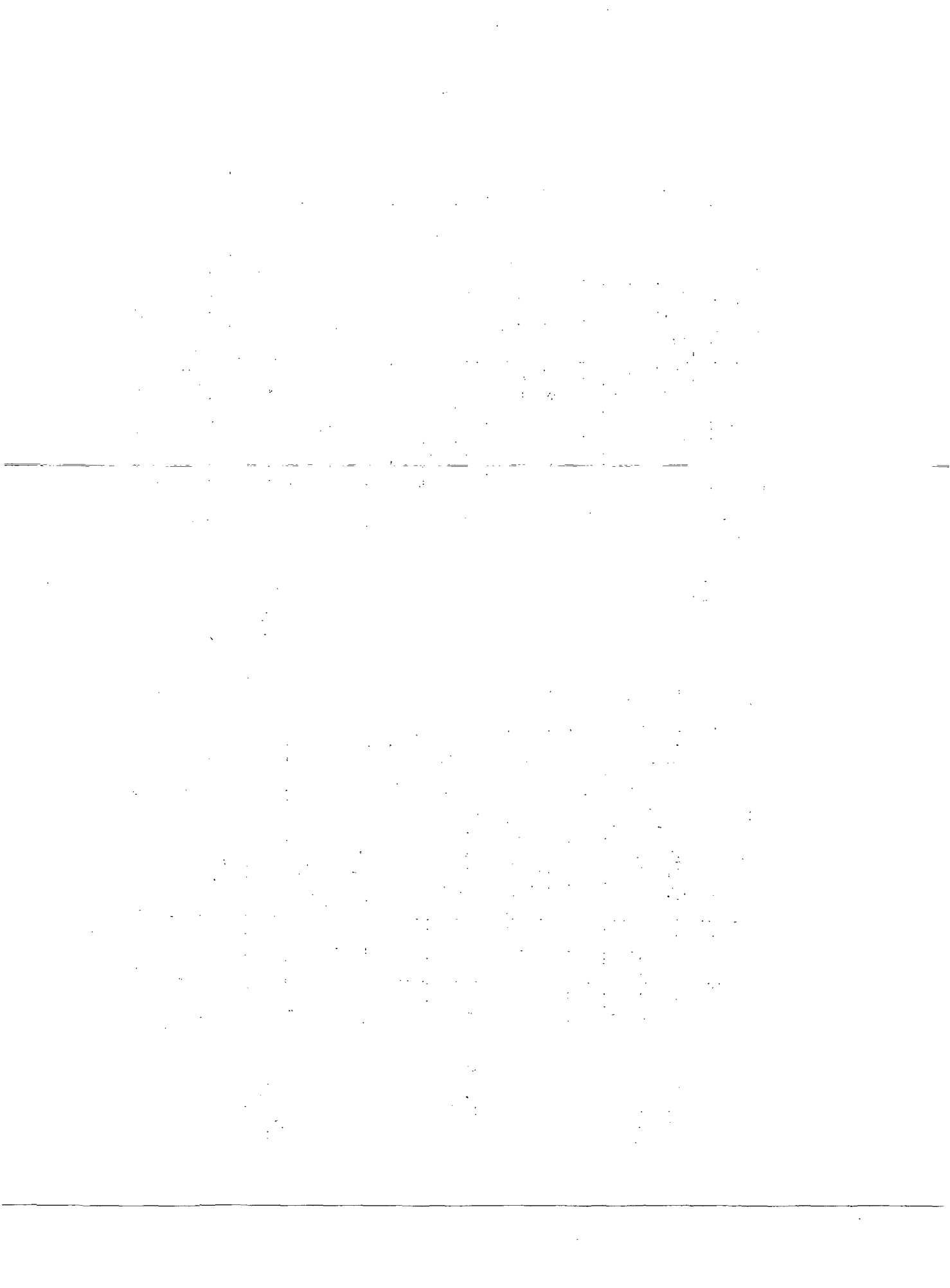
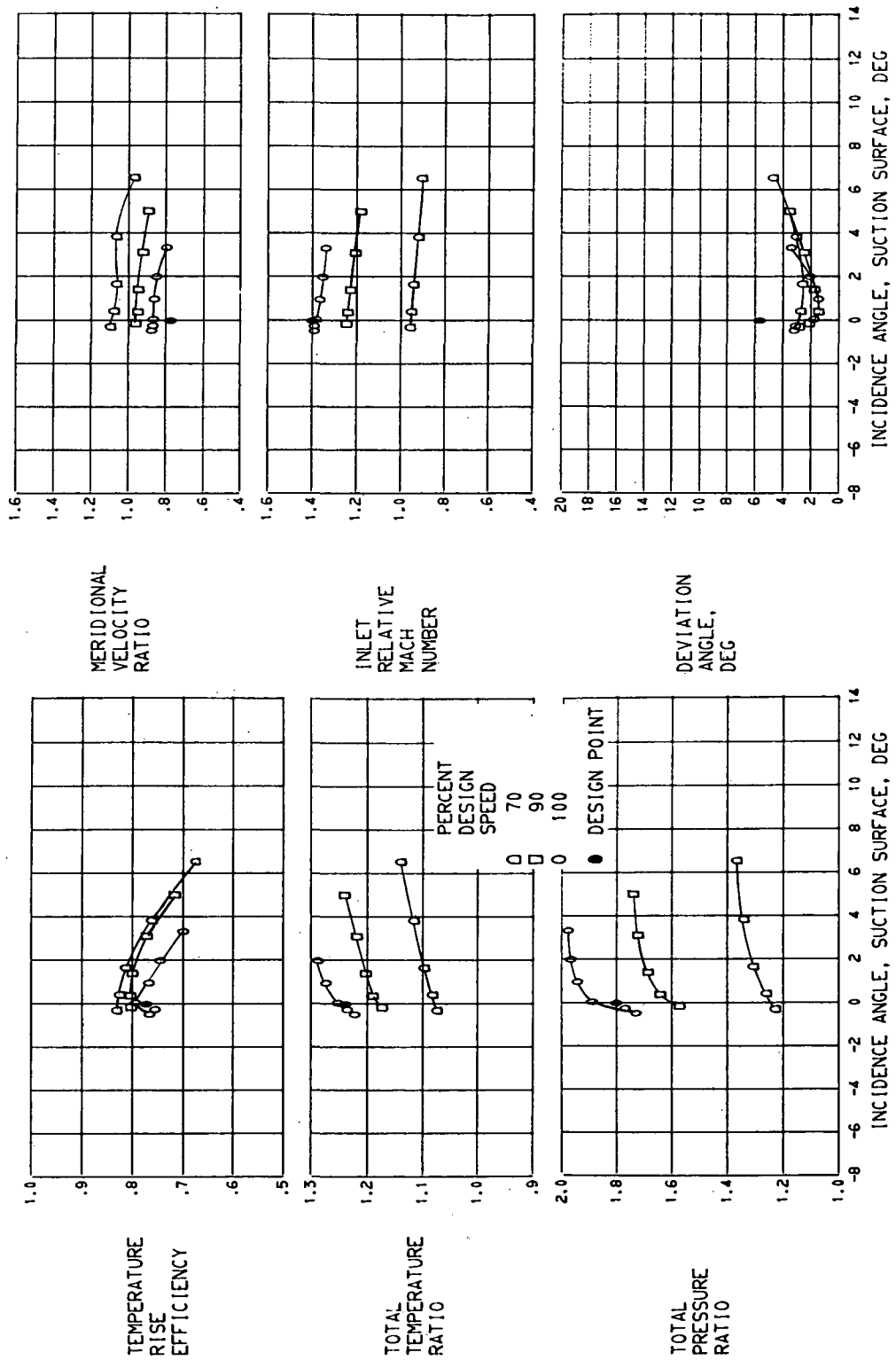
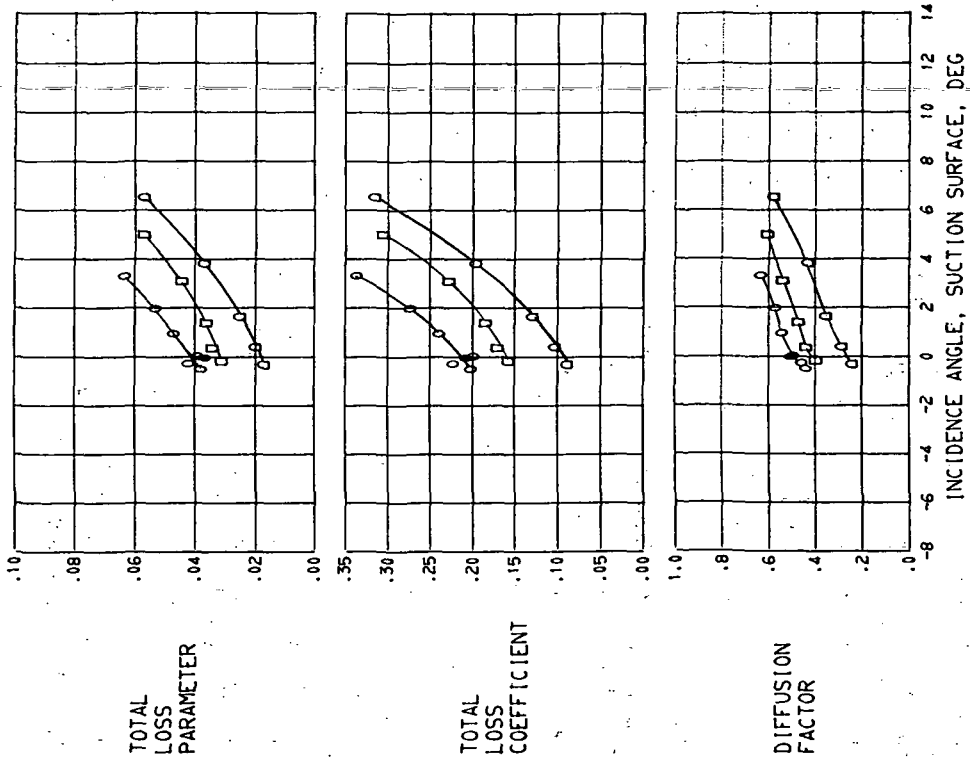

FIGURE 10. - RADIAL DISTRIBUTION OF PERFORMANCE FOR STATOR 8, 100 PERCENT DESIGN SPEED.







(A) 5.0 PERCENT SPAN.
 FIGURE 11. - BLADE ELEMENT PERFORMANCE FOR ROTOR 8.

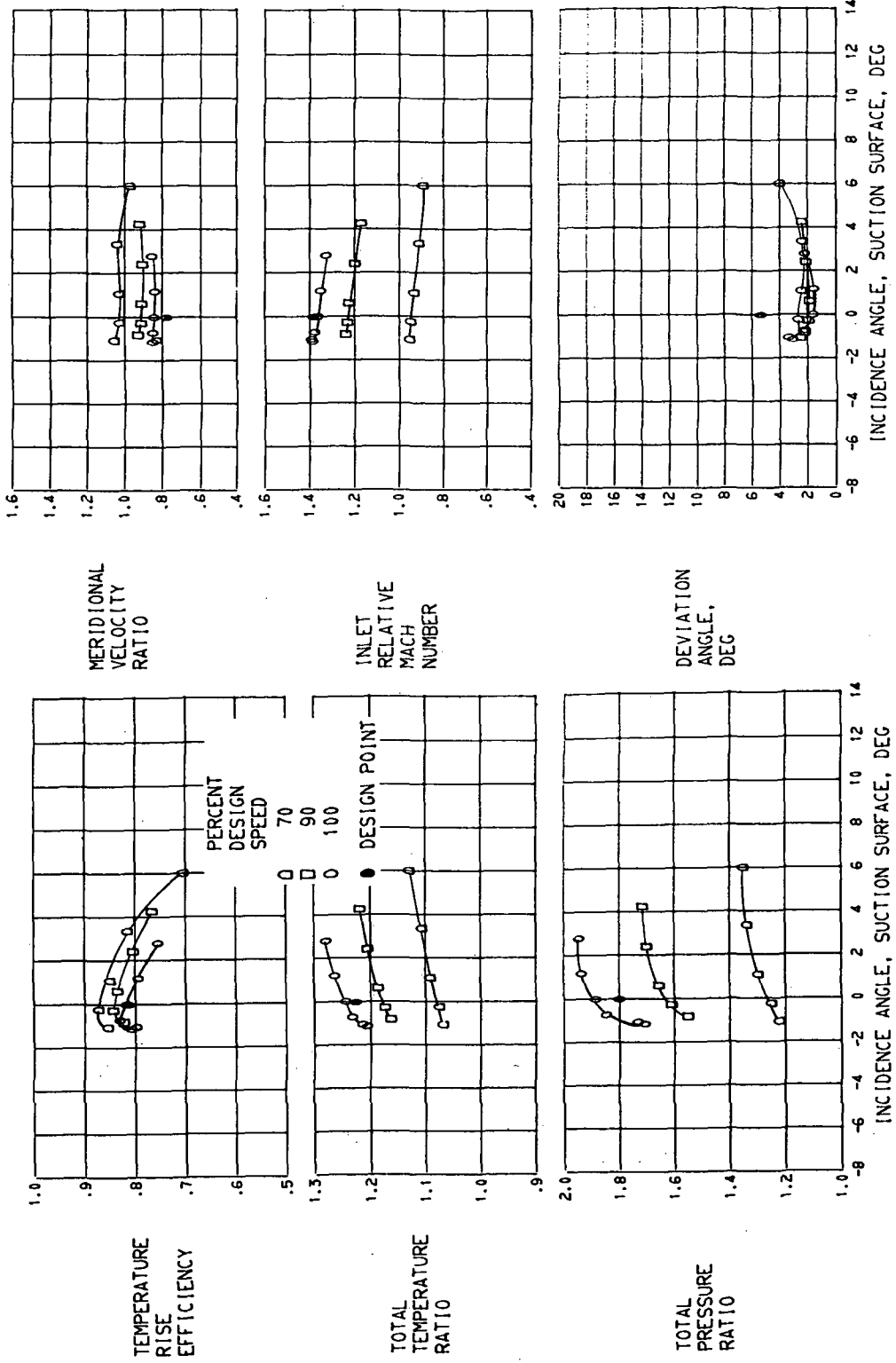

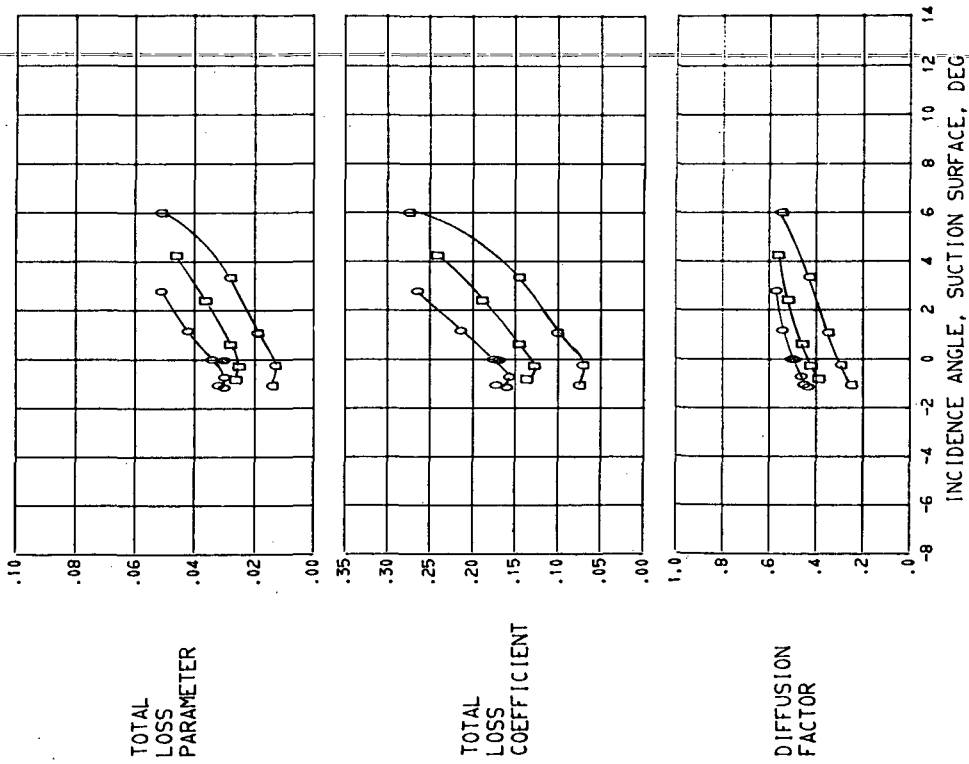

(B) 10.0 PERCENT SPAN.

FIGURE 11. - CONTINUED. BLADE ELEMENT PERFORMANCE FOR ROTOR 8.

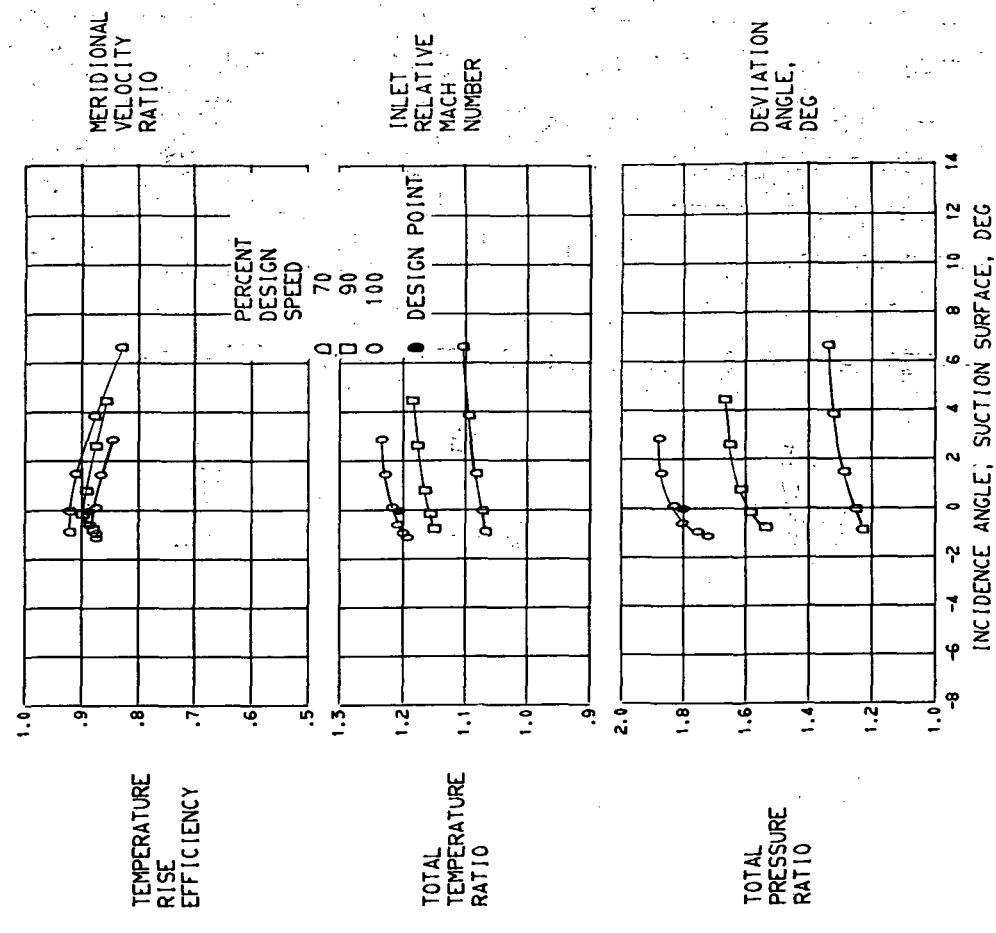
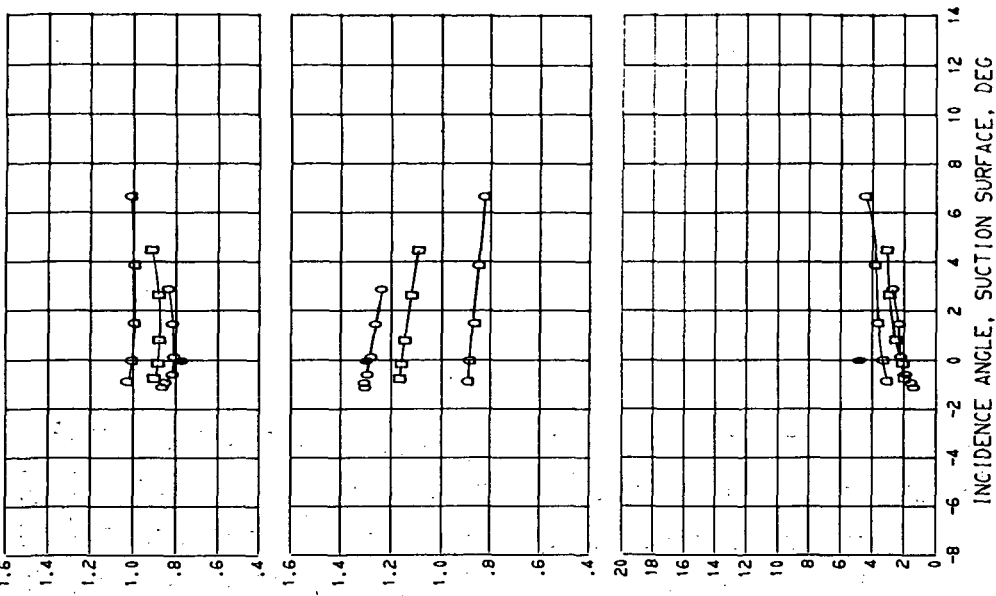

MERIDIONAL VELOCITY RATIO

INLET RELATIVE MACH NUMBER

DEVIATION ANGLE, DEG

TEMPERATURE RISE EFFICIENCY

TOTAL TEMPERATURE RATIO

TOTAL PRESSURE RATIO

PERCENT DESIGN SPEED

DESIGN POINT

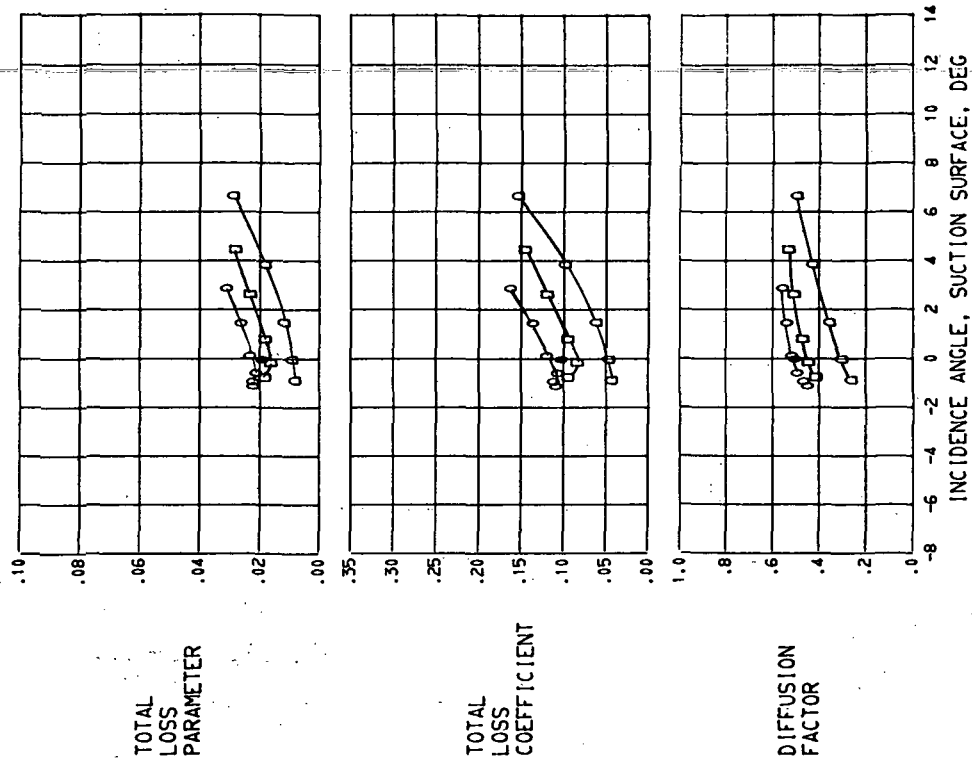
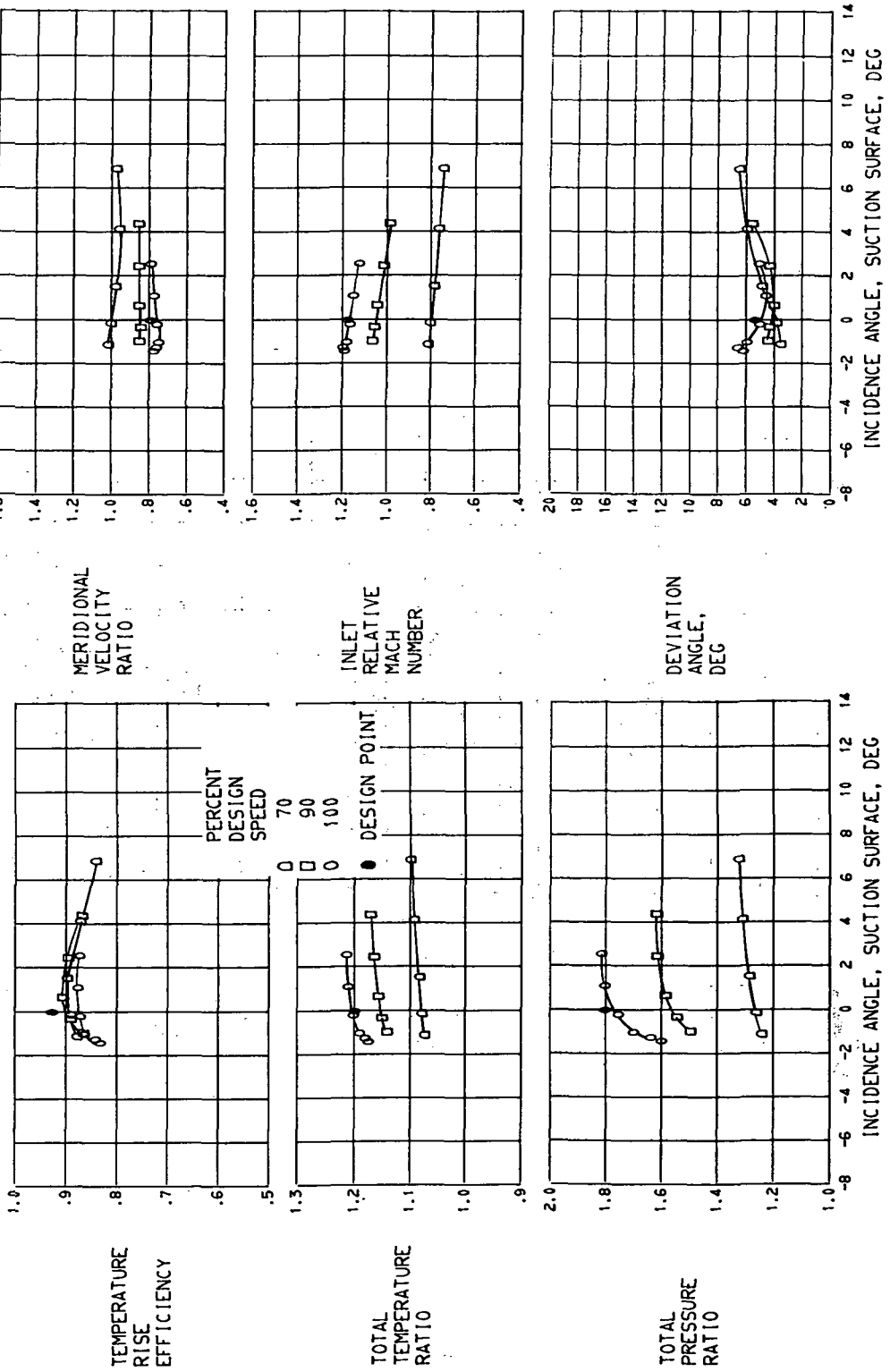

FIGURE 11. - CONTINUED. BLADE ELEMENT PERFORMANCE FOR ROTOR 8.
(C) 30.0 PERCENT SPAN.



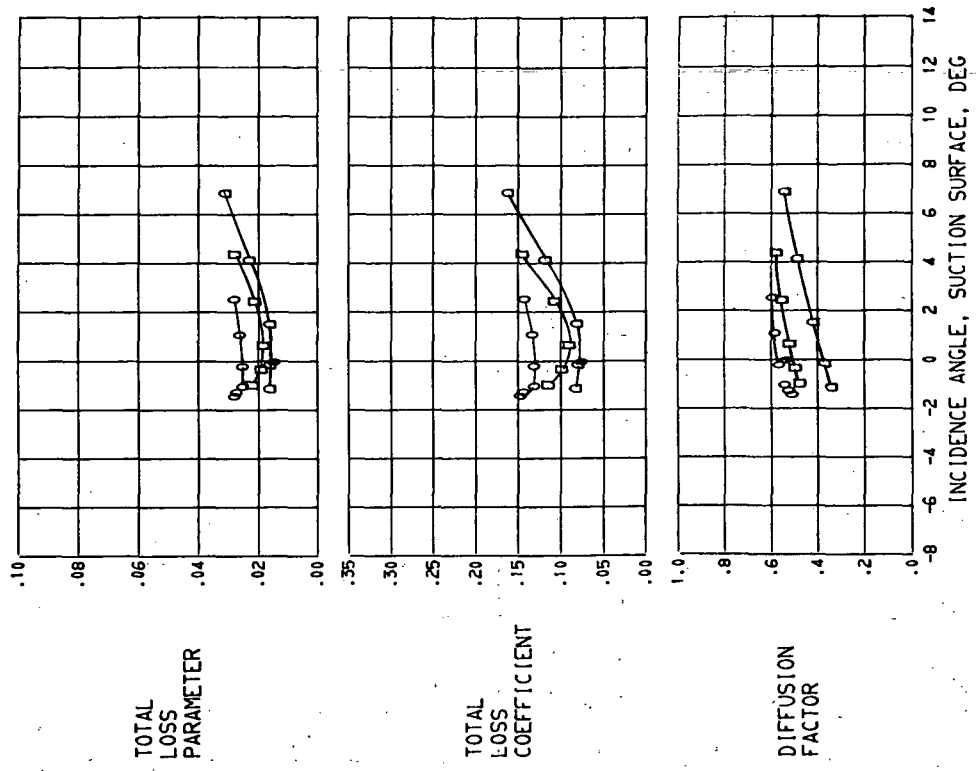
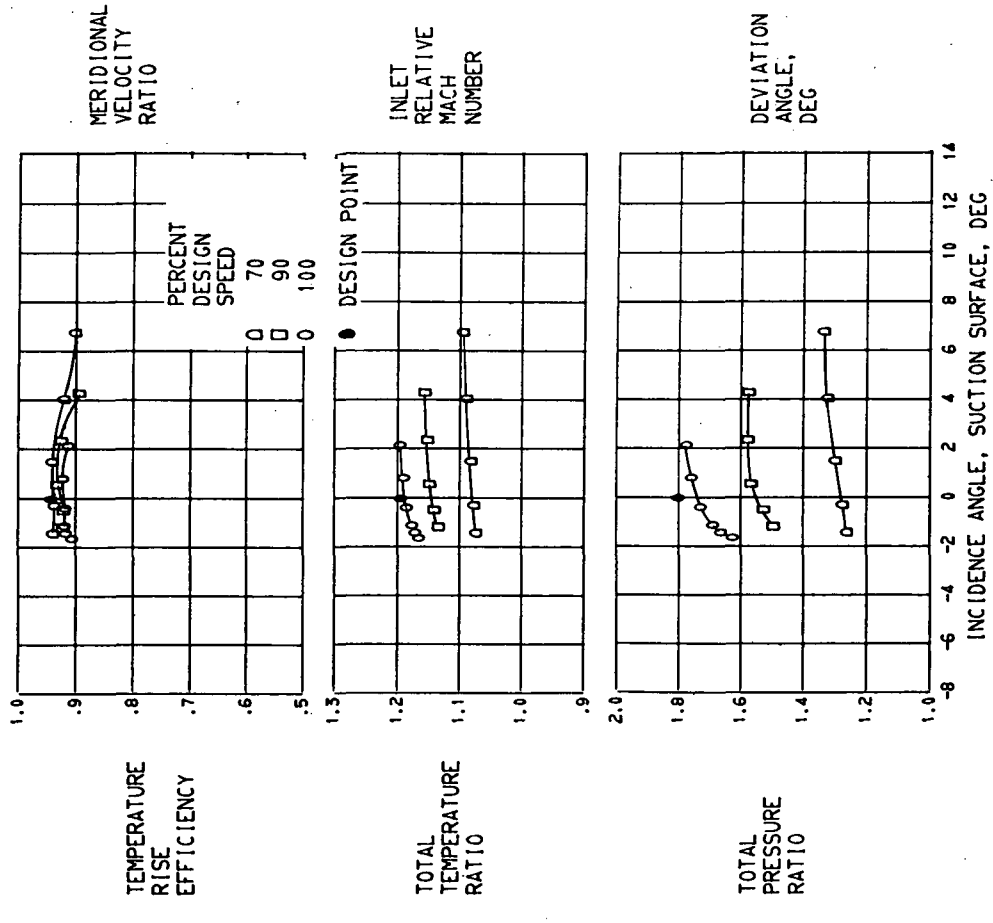
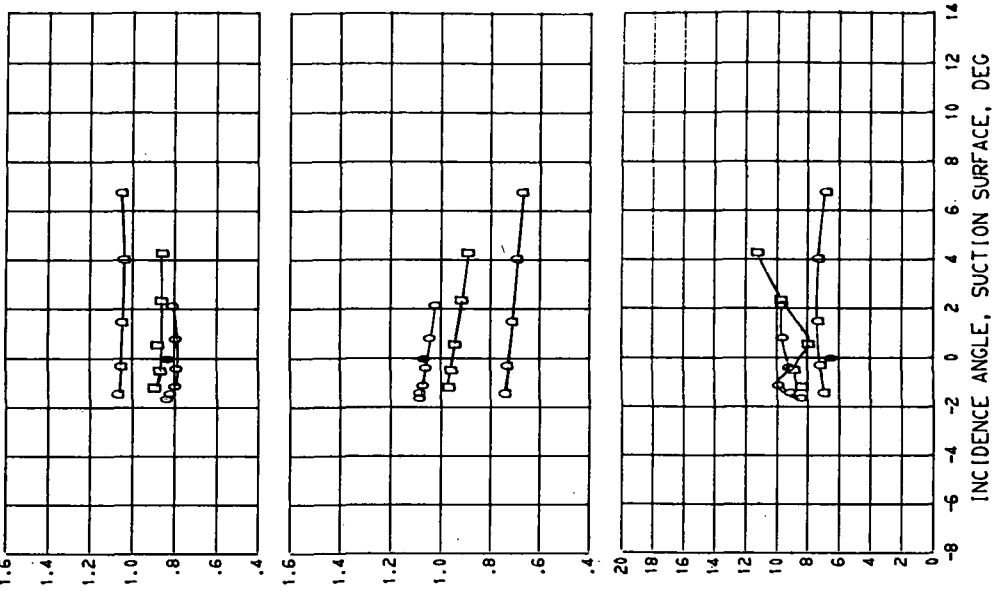

FIGURE 11. - CONTINUED. BLADE ELEMENT PERFORMANCE FOR ROTOR 8.
(D) 52.5 PERCENT SPAN.



MERIDIONAL VELOCITY RATIO

INLET RELATIVE MACH NUMBER

DEVIATION ANGLE, DEG

TEMPERATURE RISE EFFICIENCY

TOTAL TEMPERATURE RATIO

TOTAL PRESSURE RATIO

PERCENT DESIGN SPEED
 70 90 100
 □ ○ ◇

● DESIGN POINT

INCIDENCE ANGLE, SUCTION SURFACE, DEG

INCIDENCE ANGLE, SUCTION SURFACE, DEG

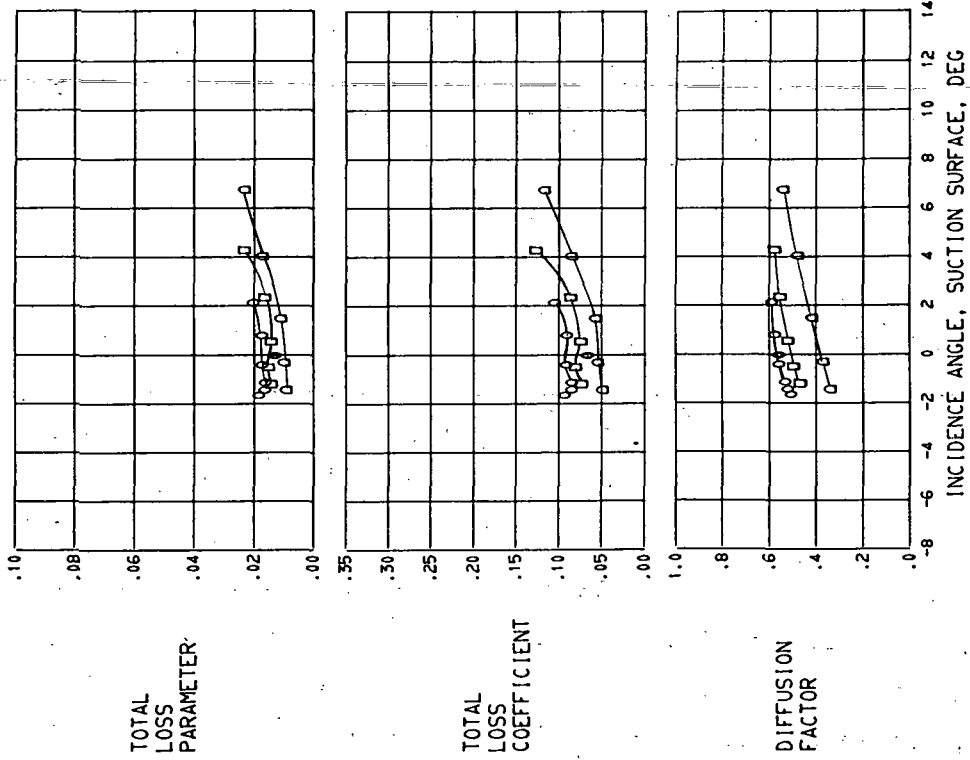

(E) 70.0 PERCENT SPAN.
 FIGURE 11. - CONTINUED. BLADE ELEMENT PERFORMANCE FOR ROTOR 8.

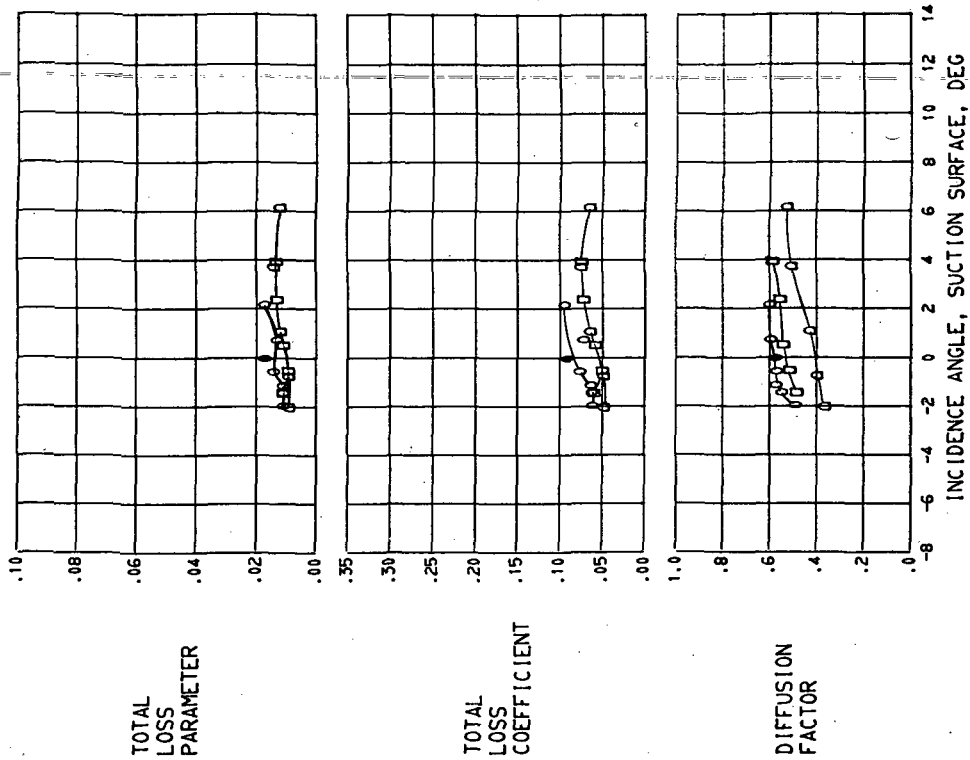

(F) 90.0 PERCENT SPAN.

FIGURE 11. - CONTINUED. BLADE ELEMENT PERFORMANCE FOR ROTOR 8.

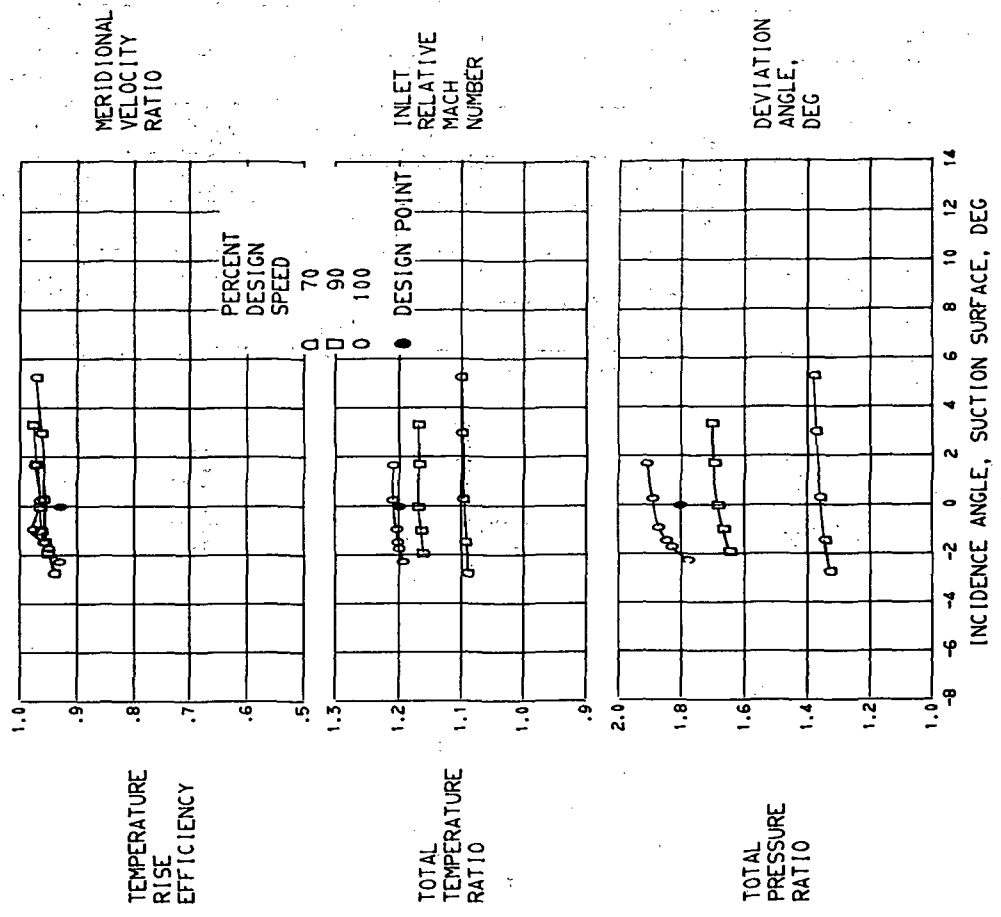
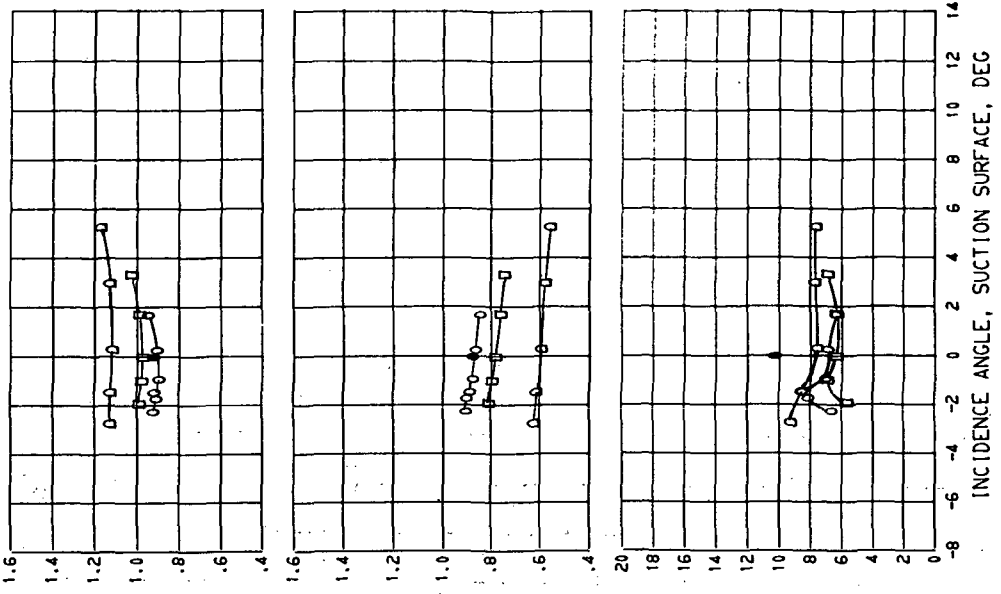

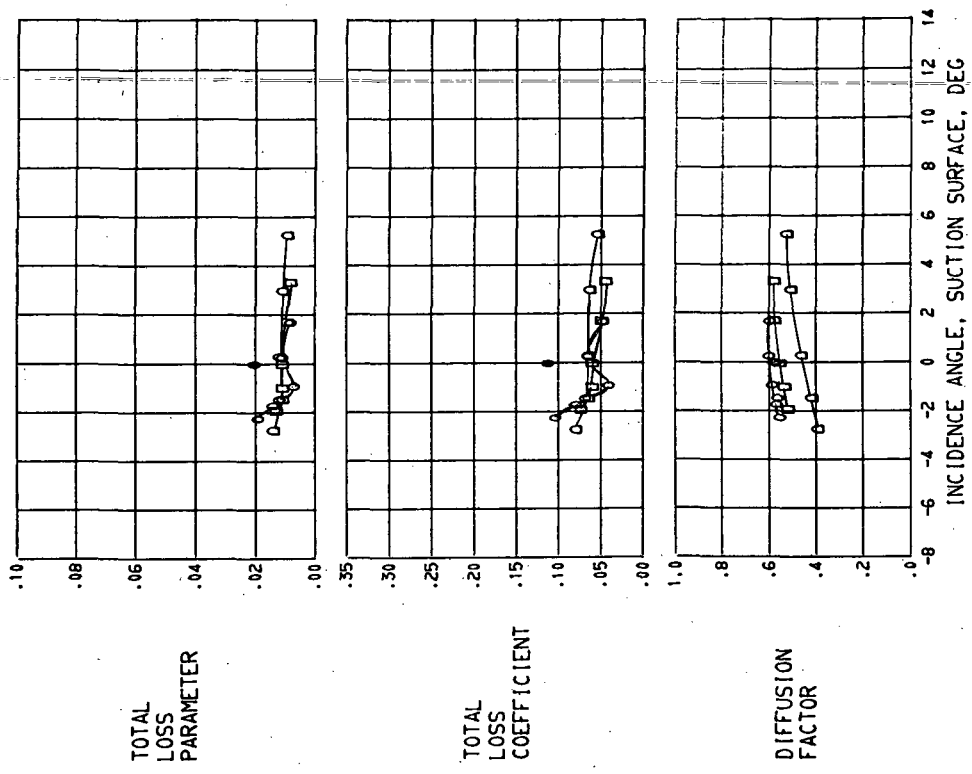

(G) 95.0 PERCENT SPAN.
 FIGURE 11. - CONCLUDED. BLADE ELEMENT PERFORMANCE FOR ROTOR 8.

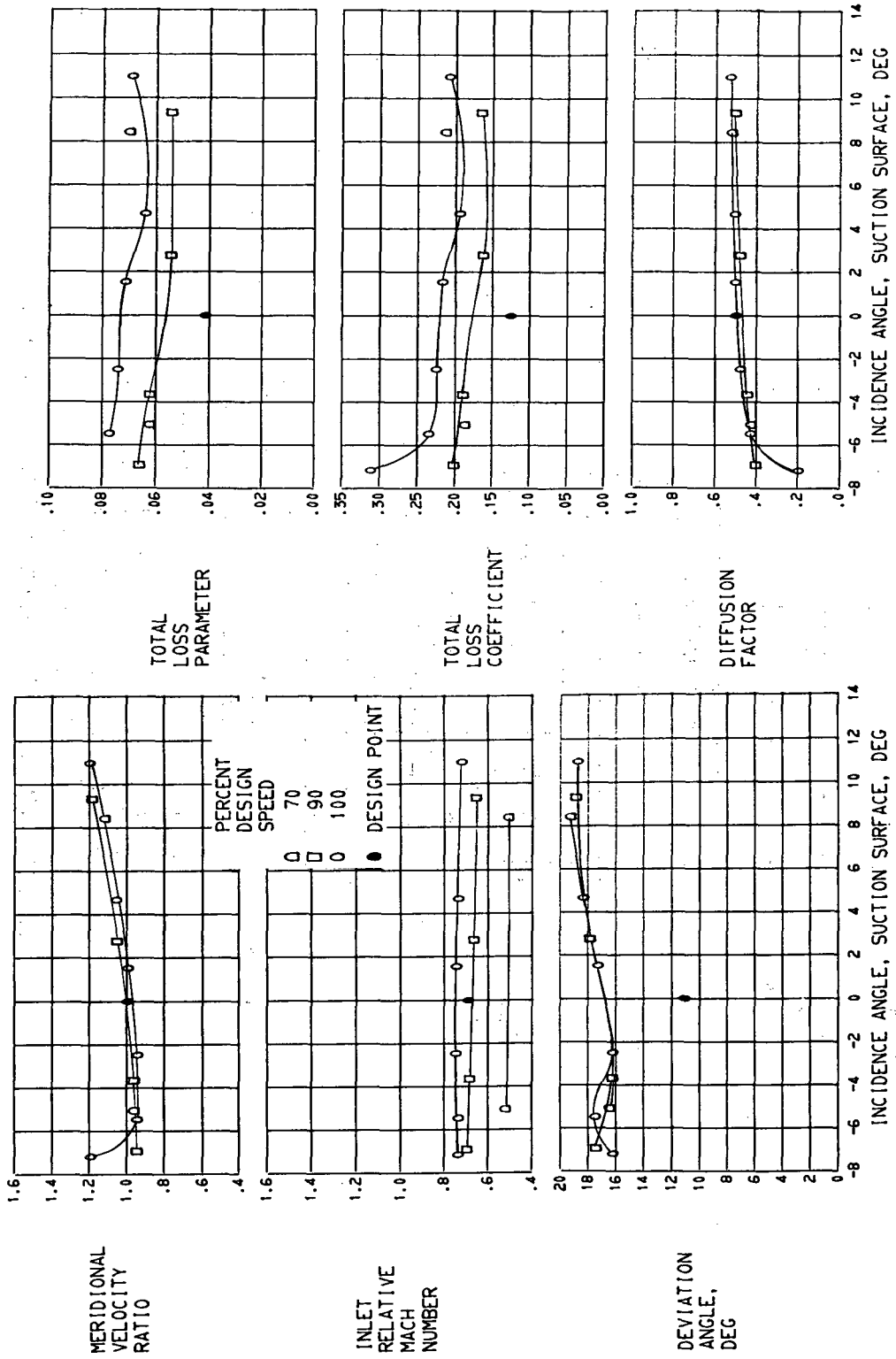

(A) 5.0 PERCENT SPAN.

FIGURE 12. - BLADE ELEMENT PERFORMANCE FOR STATOR 8.

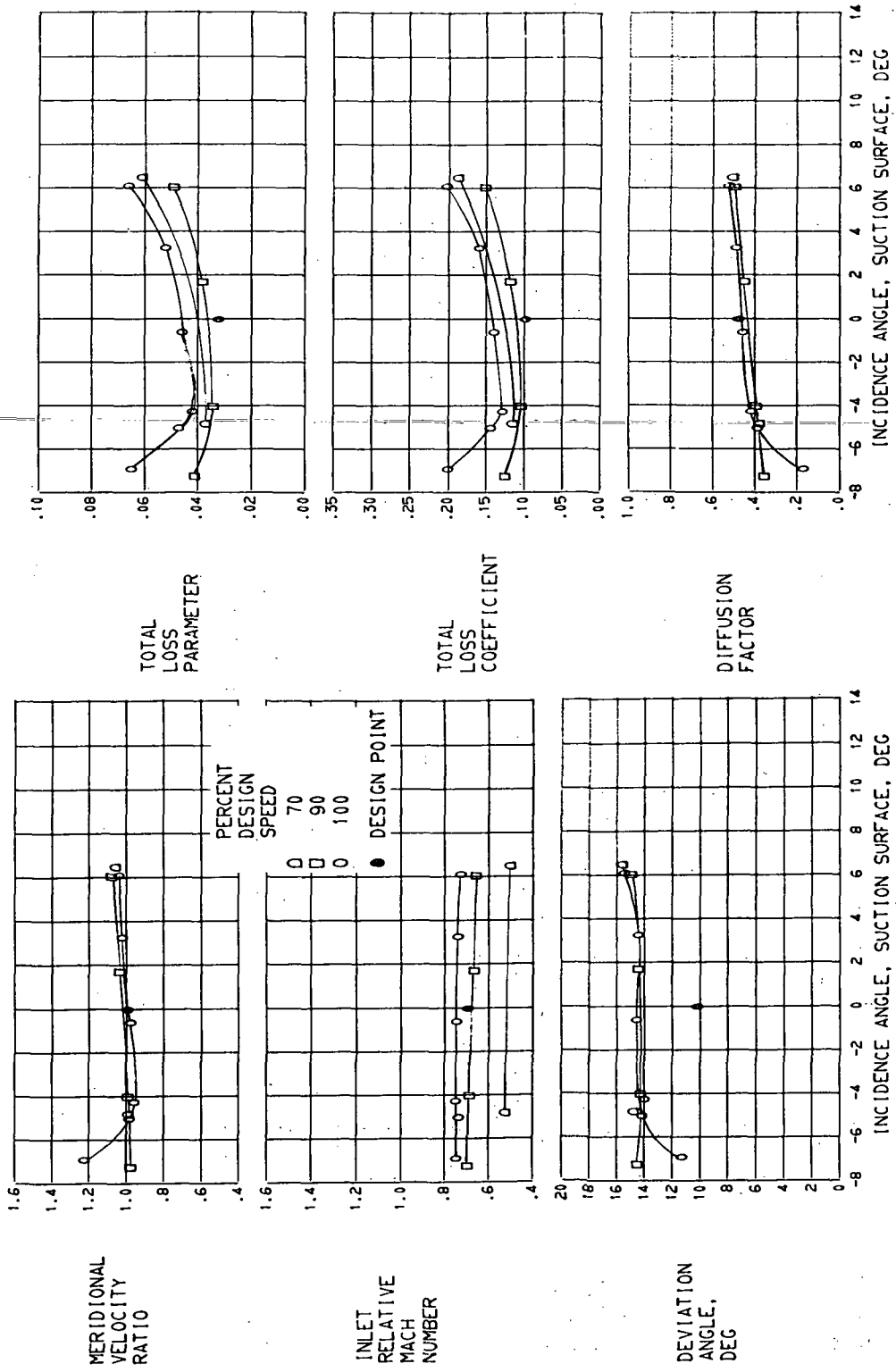

(B) 10.0 PERCENT SPAN.

FIGURE 12. - CONTINUED. BLADE ELEMENT PERFORMANCE FOR STATOR 8.

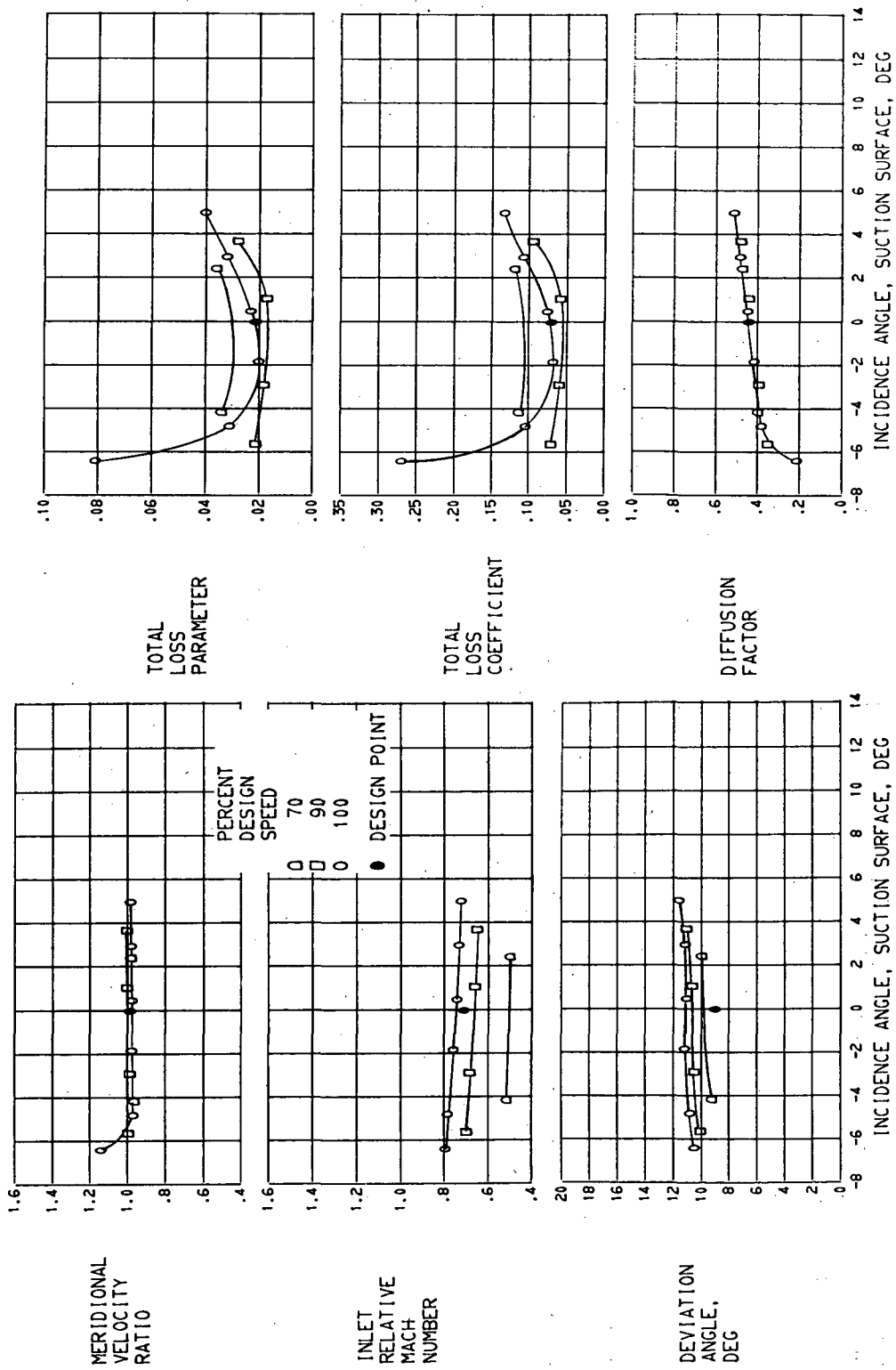

(C) 30.0 PERCENT SPAN.
 FIGURE 12. - CONTINUED. BLADE ELEMENT PERFORMANCE FOR STATOR 8.

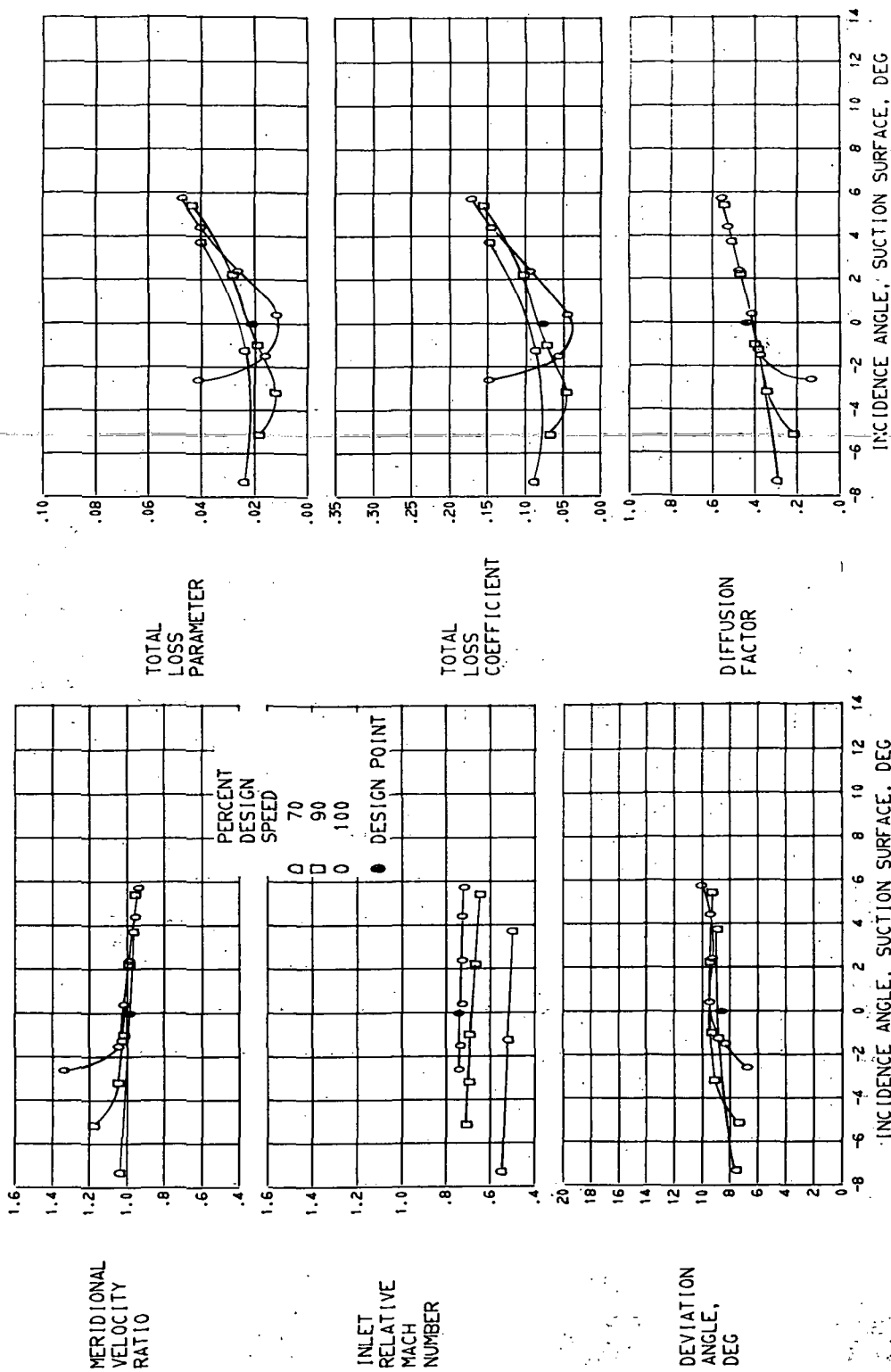

(D) 52.5 PERCENT SPAN,
 BLADE ELEMENT PERFORMANCE FOR STATOR 8.

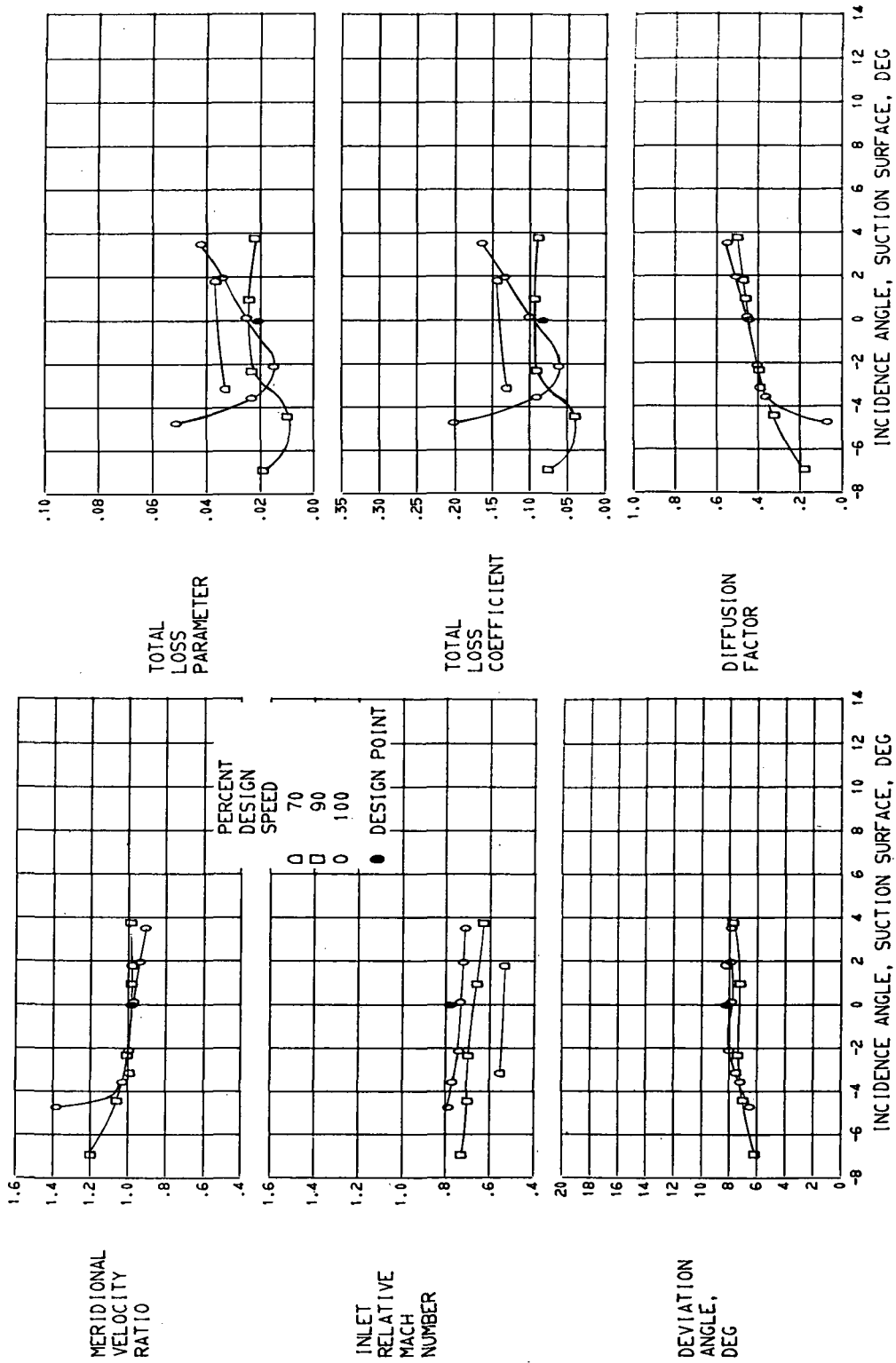

(E) 70.0 PERCENT SPAN.
 FIGURE 12. - CONTINUED. BLADE ELEMENT PERFORMANCE FOR STATOR 8.

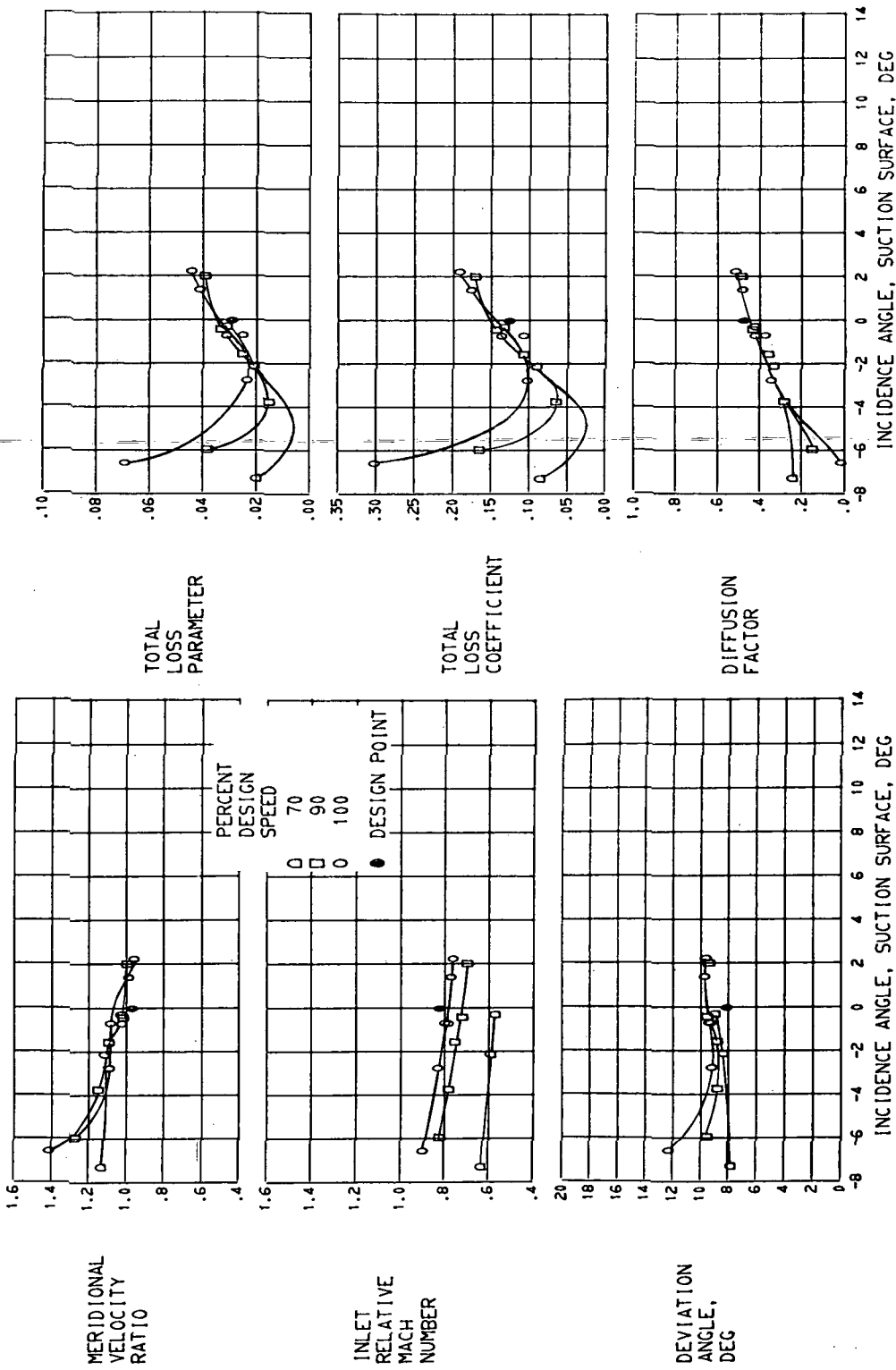

(F) 90.0 PERCENT SPAN.
 FIGURE 12. - CONTINUED, BLADE ELEMENT PERFORMANCE FOR STATOR 8.

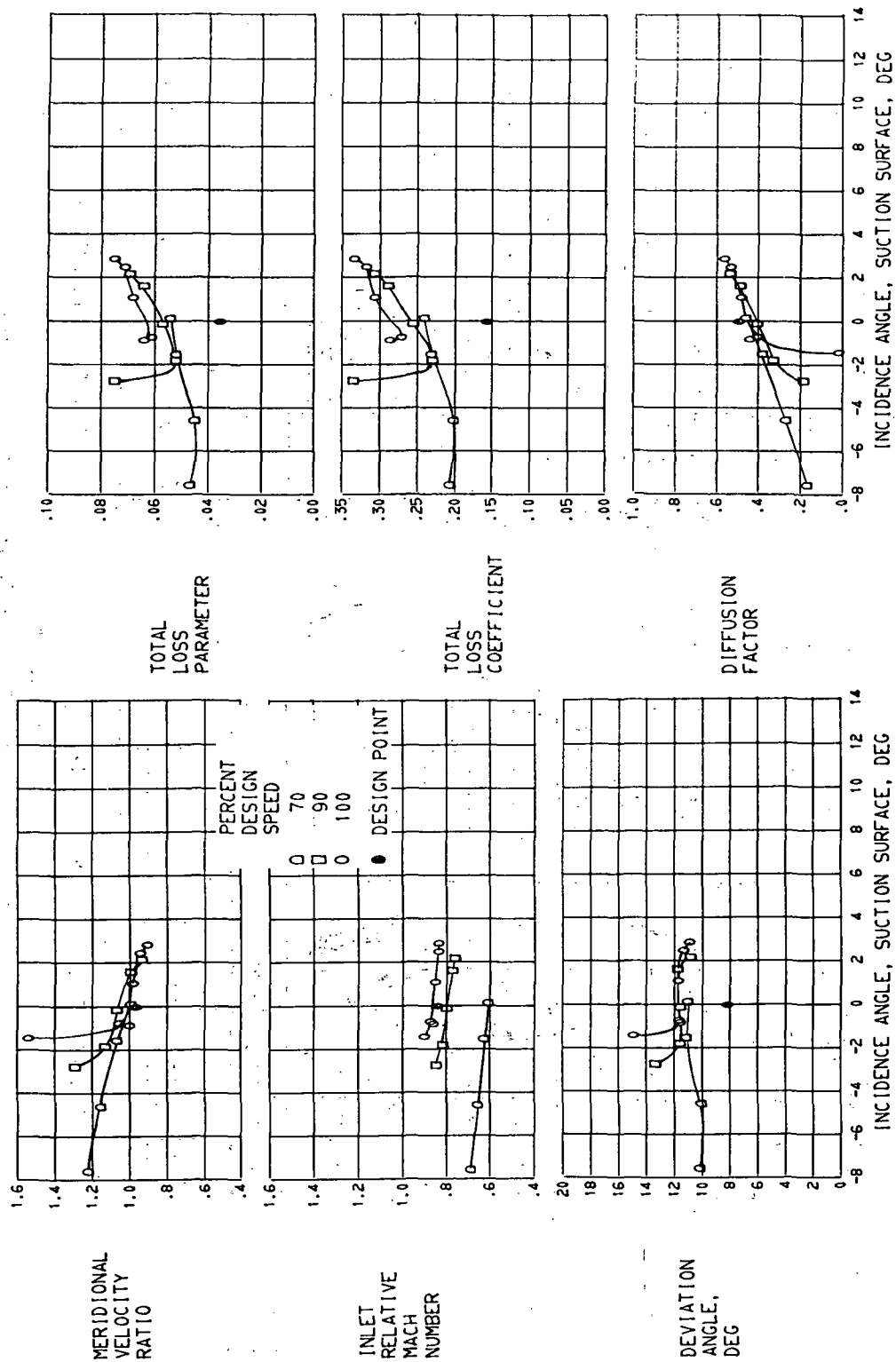

(G) 95.0 PERCENT SPAN.
 FIGURE 12. - CONCLUDED. BLADE ELEMENT PERFORMANCE FOR STATOR 8.

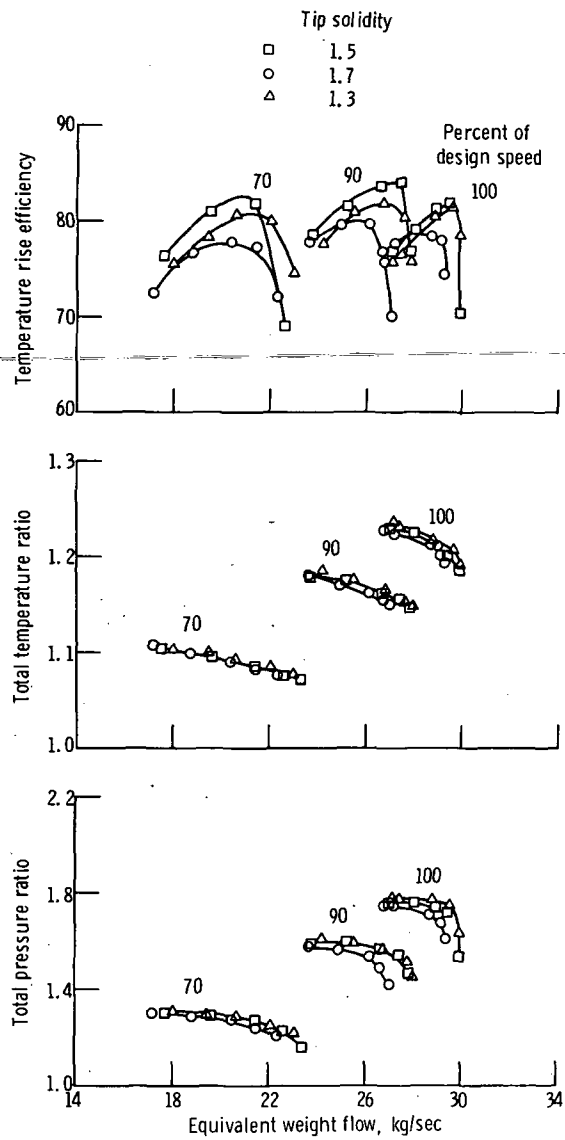

Figure 13. - Effect of solidity on overall performance.

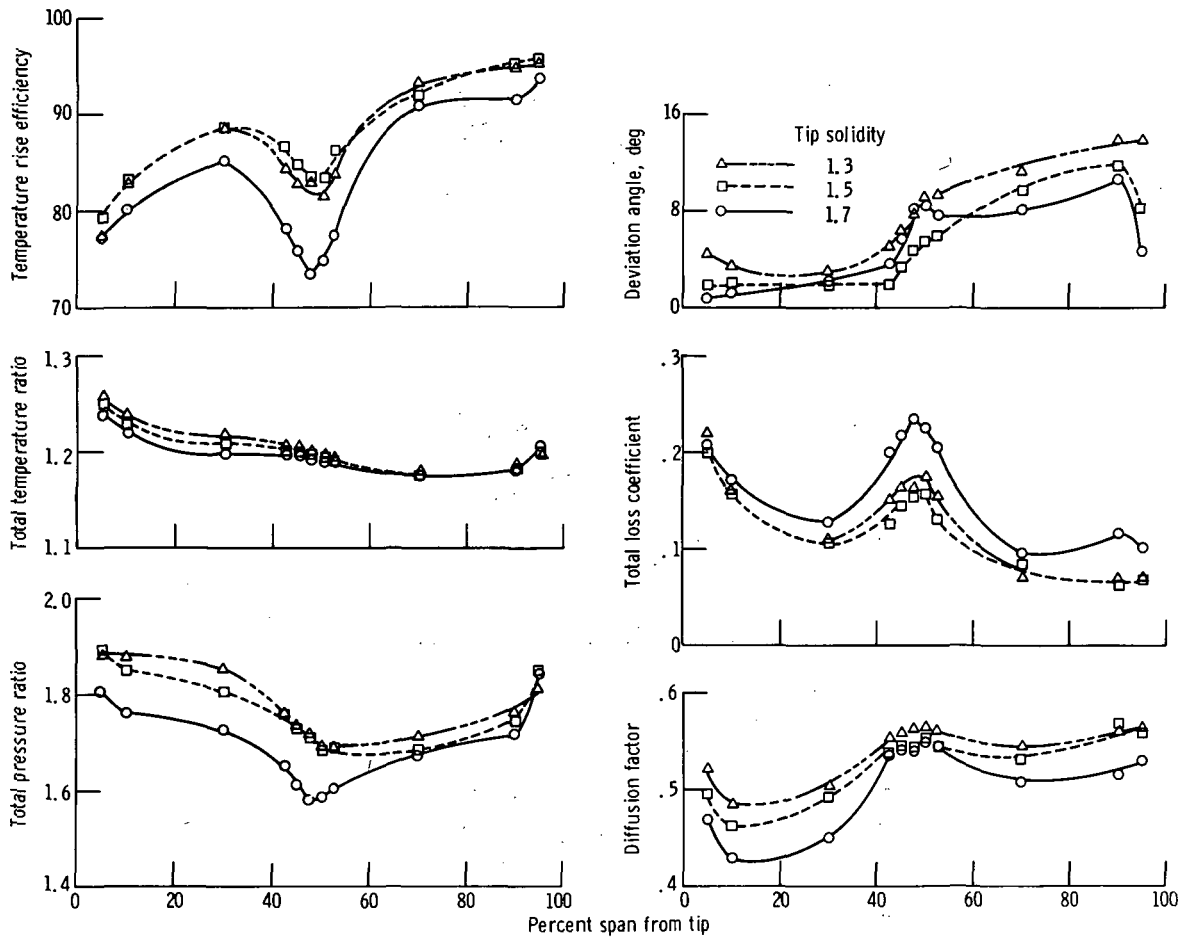

Figure 14. - Effect of solidity on rotor radial distributions at design speed and near design weight flow.

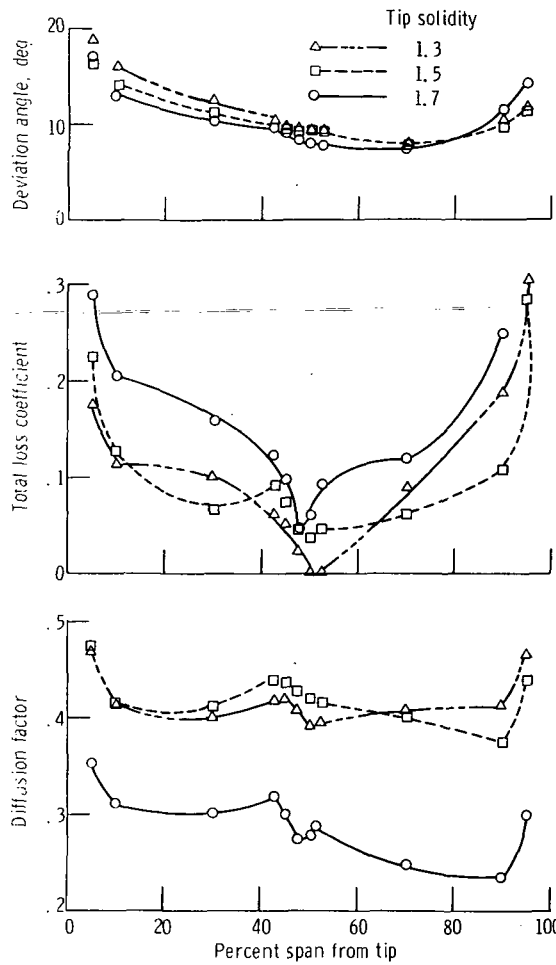

Figure 15. - Effect of solidity on stator radial distribution at design speed and near design weight flow.



POSTMASTER: If Undeliverable (Section 158
Postal Manual) Do Not Return

"The aeronautical and space activities of the United States shall be conducted so as to contribute . . . to the expansion of human knowledge of phenomena in the atmosphere and space. The Administration shall provide for the widest practicable and appropriate dissemination of information concerning its activities and the results thereof."

—NATIONAL AERONAUTICS AND SPACE ACT OF 1958

NASA SCIENTIFIC AND TECHNICAL PUBLICATIONS

TECHNICAL REPORTS: Scientific and technical information considered important, complete, and a lasting contribution to existing knowledge.

TECHNICAL NOTES: Information less broad in scope but nevertheless of importance as a contribution to existing knowledge.

TECHNICAL MEMORANDUMS: Information receiving limited distribution because of preliminary data, security classification, or other reasons. Also includes conference proceedings with either limited or unlimited distribution.

CONTRACTOR REPORTS: Scientific and technical information generated under a NASA contract or grant and considered an important contribution to existing knowledge.

TECHNICAL TRANSLATIONS: Information published in a foreign language considered to merit NASA distribution in English.

SPECIAL PUBLICATIONS: Information derived from or of value to NASA activities. Publications include final reports of major projects, monographs, data compilations, handbooks, sourcebooks, and special bibliographies.

TECHNOLOGY UTILIZATION PUBLICATIONS: Information on technology used by NASA that may be of particular interest in commercial and other non-aerospace applications. Publications include Tech Briefs, Technology Utilization Reports and Technology Surveys.

Details on the availability of these publications may be obtained from:

SCIENTIFIC AND TECHNICAL INFORMATION OFFICE

NATIONAL AERONAUTICS AND SPACE ADMINISTRATION

Washington, D.C. 20546