

P
2 mlp

**NASA TECHNICAL
MEMORANDUM**

NASA TM X-71570

NASA TM X-71570

(NASA-TM-X-71570) A DESCRIPTION OF MODEL
3B OF THE MULTIPURPOSE VENTRICULAR
ACTUATING SYSTEM (NASA) 48 p HC \$3.25
CSCL 06L

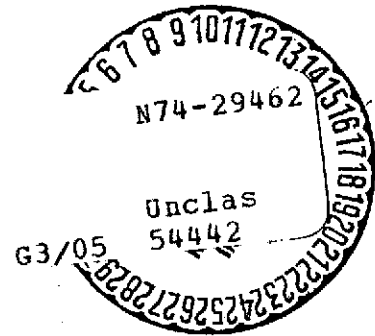

**A DESCRIPTION OF MODEL 3B OF THE MULTIPURPOSE
VENTRICULAR ACTUATING SYSTEM**

by John A. Webb, Jr.
Lewis Research Center
Cleveland, Ohio 44135
June 1974

This information is being published in preliminary form in order to expedite its early release.

A DESCRIPTION OF MODEL 3B OF THE MULTIPURPOSE VENTRICULAR ACTUATING SYSTEM

by John A. Webb, Jr.

ABSTRACT

The multipurpose ventricular actuating system is a pneumatic signal generating device that provides controlled driving pressures for actuating pulsatile blood pumps. This manual includes a description of overall system capabilities, a discussion of the timing circuitry, and calibration instructions. Detailed schematics are provided in an appendix.

INTRODUCTION

The multipurpose ventricular actuating system (MVAS) is a pneumatic signal generating device that provides controlled driving pressures for actuating pulsatile blood pumps. It was designed for use as an investigative laboratory tool in both artificial heart and heart assist studies. The original model 3 (ref. 1) was modified to provide easier operation, added timing capabilities, and some internal pneumatic improvements. This manual was written to aid the system user maintain the new MVAS and obtain maximum utilization of the system's capabilities.

GENERAL OPERATION

Overall description. - The multipurpose ventricular actuating system consists of five major sections: (1) a pneumatic supply and monitoring section, (2) an electronics section consisting of a programmer and four controllers, (3) an R-wave detector for assist applications, (4) a pneumatics controls drawer, and (5) a pneumatic switching valve box. The first four of these are shown in figure 1(a), which is a front view of

E-8009

the MVAS console. Figure 1(b) shows the rear view, exposing the pneumatic switching valve box and the pressure supply regulators.

Electrical power requirements. - The console operates on 110 VAC, 60 Hz power and should be used only with a third wire grounded outlet. Power is applied to the programmer and controllers with the switch in the lower right corner of the controller panel (fig. 1). The R-wave detector has its own power switch which should be off unless the unit is in use.

Pneumatic power requirements. - Pneumatic pressure and vacuum supply lines are connected at the top panel of the console. The pressure supply should be in the range of 20 to 40 N/cm² gage (30 to 60 psig). Pneumatic power (both vacuum and pressure) is switched on using the toggle switch in the center of the pneumatic monitoring panel. The small 0 to 40 N/cm² (0 to 60 psig) gage on this panel will register supply pressure when the console pneumatics are on.

Modes of operation. - The MVAS has two functional modes of operation. These are an assist mode and a total artificial heart mode. Figure 2(a) is a functional block diagram of the system in the assist mode. A synchronizing signal from the R-wave detector is used to trigger the programmer. In the assist mode the electronic programmer produces a square pulse which is delayed from the incoming synchronizing signal. Both the delay and the duration of that pulse are adjustable. A counter can be set to trigger on each, every other, or every fourth incoming synchronizing pulse. This is used to prevent a patient's dependence on the assist pump. The square pulse from the programmer then drives a pneumatic switching valve whose inputs are pressure and vacuum. The levels of pressure and vacuum applied to the switching valve are set by the electronic controllers operating in a manual (or open loop) mode. The electrical output of the controllers is converted to a pneumatic signal using the electro-pneumatic transducers. The switching valve output alternates from pressure to vacuum to provide the driving pressure for the assist pump.

When the MVAS is set in the total artificial heart mode, as shown in figure 2(b), the R-wave detector is not used. The programmer in this mode uses a free running oscillator which forms its own square wave pulse. The heart rate and percent systole (contraction or pressure portion of the cycle) are adjustable. This square electrical pulse drives two pneumatic switching valves to drive the right and left ventricles of the artificial heart. The pressure and vacuum supplies to the switching valves can be controlled electronically by applying a suitable feedback (F.B.) to the controllers and adjusting the set point (S.P.) or they can be manually set. The programmer also puts out two additional square pulses which are delayed from the pulses which drive the ventricles (as depicted on the programmer panel - see fig. 3). These delays are adjustable as indicated in figure 2(b). Each of these signals controls a pneumatic switching valve to provide a pressure waveform that drives the blood valves in the artificial heart. The pressure and vacuum supplies to these switching valves are adjusted with regulators mounted in the pneumatic monitoring panel.

Programmer panel. - The panel arrangement for the programmer is shown in figure 3. The mode selector switch consists of the four push buttons near the top of the panel. These allow selection of the assist mode (green) or the total artificial heart mode (red). The remaining two buttons provide a manual mode (blue) and an auto assist mode (yellow) which provides asynchronous pumping in the event of a loss of the incoming sync signal.

When in the assist mode a green line on the panel indicates the settings which must be made. These are: counter, delay from R-wave, and ejection duration. The delay and duration settings are calibrated in milliseconds. An additional feature is the external sync input jack at the lower portion of the panel. This allows the operator to synchronize the assist pump with an external signal. The circuit will accept a square voltage pulse and trigger on the positive slope of the square pulse. A panel light to the right of the jack will flash each time the circuit is triggered.

When in the total artificial heart mode, a red line on the programmer panel indicates the necessary settings. These are: heart rate, percent systole, outflow and inflow valve delays. Setting the inflow and outflow valve delays requires a decision of single or double delay with the toggle switch above the thumbwheel switches used for adjustment of delays. These adjustments are made on the same switches used for delay and duration in the assist mode. In the artificial heart mode a provision for controlling heart rate with an external voltage is made with the EXT H. R. jack at the lower left corner. A sync out signal is also made available for use as an oscilloscope synchronizing signal.

When the ventricles of the artificial heart or the assist device are in the contraction phase or in systole, the yellow light in the center of the panel is on. The alarm at the very top of the panel is available for use in the auto assist mode. It makes a high pitched sound when the synchronizing signal is lost. It can be turned off with the adjacent switch.

Two test jacks (T1, T2) are provided at the lower right corner of the programmer panel. These can be patched to any one of seven programmer signals at the rear of the console for monitoring.

Programmer block diagram. - An overall block diagram of the programmer circuits is provided in figure 4. The mode selector switch, S1, is represented as a rotary selector switch, but in the actual circuit it is an electronic biasing network (see fig. 11 in schematics section). The signals defined with letters on this diagram are signals that can be patched into the two test jacks on the programmer panel. A list of these signals and the color code on the card test jacks is provided in table I. To ease visualization of the various modes of operation, the programmer block diagram of figure 4 has been broken down in figure 5.

Manual mode. - Figure 5(a) indicates the blocks in use in the manual mode. The manual block is essentially a momentary switch which closes when the manual button is pushed. This turns on the drive amplifiers of all three programmer outputs, placing the unit in systole.

Assist mode. - Figure 5(b) shows the programmer in the assist mode. The R-wave detector output is applied to trigger a monostable multivibrator. This multivibrator provides a pulse to drive both a trigger

indicating light and the dual flip-flop used for a counter. Selection of the counter outputs is made with S2. This signal triggers Mono 1 to provide a delay from the incoming sync signal. Mono 1 triggers Mono 2 to provide a duration period. This signal is inverted and applied to the ventricle drive amplifier. A recording of these waveforms is provided in figure 6(a). The ventricle drive amplifier is in systole when its output is 0.4 volts.

Auto assist. - When the auto assist button on the mode selector switch is pressed, the console goes into the assist mode and functions as indicated in the previous section. However, in the event that the R-wave synchronization is lost, the unit automatically switches to the total artificial mode. This will drive the assist pump asynchronously at the heart rate and percent systole set on the panel. When this mode is used, the auto assist button will remain illuminated. To reset the unit back into the assist mode once it has switched, push the auto assist button (not the assist button as this will put the console into the assist mode and remove the auto assist feature). The auto assist circuits are shown in figure 4 as an R-wave comparator, an S1 control, and an optional alarm. The R-wave comparator compares the R-wave amplitude signal from the R-wave detector to a reference voltage. When the ECG is not present, this amplitude will become smaller than the reference voltage and the comparator will switch. The comparator output drives the S1 control which switches the programmer from the assist mode to the total artificial heart mode.

Total artificial heart mode with single delays. - Figure 5(c) shows the total artificial heart mode with valve delays set for single delays. The triangle wave oscillator provides an adjustable heart rate. This triangle wave is compared to a reference voltage (% systole) with the ventricular comparator. The square wave at the output of this comparator is used to drive the ventricle drive amplifier.

To obtain the delays from the leading and trailing edges of the ventricle drive signal, the two monostable multivibrators are used, with Mono 1 setting the delay from the leading edge (beginning of systole) of the ventricle drive signal and Mono 2 setting the delay from the trailing

edge. These signals are shown in figure 6(b). The outflow valve drive signal is obtained by applying the output of Mono 1 and the inverted output of the ventricular comparator to an R-S flip-flop. The same is done for the inflow valve, using the output of Mono 2 and the non-inverted output of the ventricular comparator. The drive signals are also presented in figure 6(b). Again, the drive signals are in systole when they are about 0.4 volts.

Total artificial heart mode with double valve delays. - In this mode the ventricle drive signal is obtained the same way as for the single delays, but the valve drive signals are obtained by summing the percent systole signal with a voltage proportional to the delay and comparing this reference with the triangle wave (fig. 5(d)). This provides a delay at both the leading and trailing edge of the ventricle waveform. These signals are shown in figure 6(c). (The reference voltages, V_1 and V_2 , are the same voltages used to control Mono 1 and Mono 2 periods for single delays and the assist mode.)

Pneumatic control channels. - Figure 7 shows the components used for one pressure and vacuum control channel shown in the block diagram of figure 2(b). The controller drives an electro-pneumatic transducer which converts the current output of the controller to a pressure signal. A limited range adjustment is available at the transducer. This signal is then fed to a computing relay to bias the pressure signal. The output of the computing relay is fed to a volume booster relay to improve flow capacity. The vacuum channel is basically the same, except a vacuum supply is applied as a reference to the pneumatic components and a reservoir is provided on the output of these channels.

Pneumatic switching valve response. - A test was made to check the performance of the pneumatic switching valves. Using the left ventricle driving pressure, two recordings were made of the pressure response in a 100 cubic centimeter volume attached to a 25 cm and 250 cm drive line. These transients are shown in figure 8. This gives an indication of the electrical to pneumatic signal delay of the switching valves and the response capability of the pneumatics.

CALIBRATION AND CHECKOUT

Calibration of R-wave detector. - The following is a step by step procedure for calibration and tuning of the R-wave detector which assumes the reader's knowledge of the circuit described in reference 2. All amplifiers are marked and are referred to by symbols such as A10, where 10 is the amplifier number. This procedure requires that the unit be removed from the console and the cover removed from the box.

A. Notch filter

(1) Remove A2 and apply a 1 volt peak-to-peak 60 Hz signal at the output terminal of A2 (see fig. 9 for terminal arrangement).

(2) Adjust P-1 to minimize 60 Hz signal at the output of A5. Then adjust P-2 to do the same. Continue iterating until the maximum possible attenuation of the 60 Hz signal is achieved.

B. Pulse-width discriminator

(1) Remove A5 and A13. Remove shorting bar from between test points 1 and 2 and connect test point 2 to common.

(2) Apply 10 millisecond square pulses to the output terminal of A5 at a frequency of 4 Hz. The pulses should be about 10 volts in amplitude and should cross through zero volts with respect to common. A circuit for generating these pulses is shown in figure 10 of reference 2.

(3) Use the leading edge of the pulses to trigger the sweep of a dual trace oscilloscope.

(4) Monitor the pulse input and the output of A11 on dual trace scope.

(5) Adjust P-4 until the signal at the output of A11 just triggers on the trailing edge of the input pulse as shown in figure 10.

(6) Repeat step 5 for the output of A10 by adjusting P-3 and the output of A14 by adjusting P-6.

C. Integrator drift

(1) Remove A9 and replace A13. Make sure shorting bar between test points 1 and 2 is removed and point 2 is shorted to common. Short test point 6 to +15 volt supply.

(2) Monitor the output of A13 on oscilloscope and digital voltmeter.

(3) Adjust P-5 to minimize the drift of the output of A13. (If a high drift rate is initially observed, amplifier may go into saturation. When this occurs, turn supply power off and on to re-zero the output of A13.)

(4) Fine adjustment can be obtained by using the digital voltmeter.

NOTE: Be sure to replace shorting bar between test points 1 and 2 before attempting operation of the R-wave detector.

Calibration of programmer. - It is recommended that the programmer be calibrated by using a digital counter/timer, however, if lesser accuracy is acceptable the unit can be calibrated with an oscilloscope. When calibrating settings allow for a 2 hour warmup period. The trim pots are referred to as P4 for pot number 4 and figure 11 gives the arrangement of these pots on the circuit cards.

A. Internal oscillator

(1) A square wave output from the oscillator is provided at the sync out terminal on the programmer panel. This signal is used for calibrating the heart rate pot and for adjusting the oscillator symmetry.

(2) With the unit in the total A.H. mode, set the heart rate to 60 beats per minute (BPM). Adjust the symmetry of the square wave by using P3. This trim pot varies the duration of only one-half of the cycle. Adjust until both halves of the square wave are equal in duration.

(3) Once symmetry is achieved, adjust P1 to obtain a period of 1000 ms (measured on counter or scope). Then set the heart rate to 120 BPM and adjust P2 to obtain a period of 500 msec. Return to 60 BPM and readjust P1. Continue iterating, adjusting P1 at 60 BPM and P2 at 120 BPM until the desired accuracy is achieved.

B. Percent systole

(1) With the programmer in the total A.H. mode, and the heart rate set to 60 BPM, set percent systole to 00. Connect the yellow wire (T1) in the rear of the console to the yellow test terminal. Adjust P4 until the systolic duration (time that the signal at T1 is in low state) is at a minimum. This is accomplished by monitoring the signal on a scope and adjusting the trim pot (P4) until the zero state pulse disappears, then back the pot up until a short duration spike appears. This adjustment can also be made by setting the duration slightly less than 1 ms by using the counter/timer.

(2) Set the percent systole pot to 50 and adjust P5 to obtain a pulse duration (zero state) of 500 msec.

C. Double delays

(1) These settings are somewhat more difficult to measure since they require a measurement of the time delay between two signals. Furthermore accuracy is somewhat compromised since one setting adjusts two delay times. The signals to be monitored are sketched in figure 12.

(2) With the programmer in the total A.H. mode at 60 BPM and 50 percent systole, set the outflow valve delay switch to double and the delay pot to 001. Using P6, adjust t_1 to 1 msec. Set the delay pot to 100 and adjust P7 for a t_1 of 100 msec. Check both delays and adjust P7 to compromise any differences (differences of up to 10 % are normal).

(3) Repeat the above steps for the inflow valves using P8 at 1 msec and P9 at 100 msec.

D. Delay and duration

(1) Adjustment of delay and duration settings is done with the programmer in the assist mode. A trigger is provided by patching the sync out terminal into the ext sync phone jack and setting pulse rate to 60 BPM. Connect the test jacks to the white and red card terminals at the rear of the console. Set the delay pot to 001 and adjust P10 to achieve a 1 msec pulse duration in the zero state at the white terminal. Then set the pot to 200 and adjust P11 for a 200 msec pulse width.







(2) Repeat the above for duration using P12 at 1 msec, P13 at 200 msec, and the red terminal.

NOTE: Calibration of the delay and duration settings also calibrates the single delays used for total A.H..

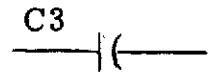
Setting pressure channels. - The controlled pressure channels can be set to obtain a desirable range of pressures with an adjustable pressure bias. For the pressure channels (not vacuum) set the controller output to 0. Monitor this pressure on the monitoring panel and adjust the bias regulator in the drawer (see fig. 13) to achieve a zero pressure reading on the gage. Set the controller to 100 and monitor the full-scale pressure on the gage. If the range is unsatisfactory, some range adjustment can be made at the electro-pneumatic transducer. Adjust the range screw to give desirable full scale range and then re-correct the bias. This process may require several iterations. A similar approach is used for setting the vacuum controllers except the bias should be adjusted to give zero gage pressure at a controller setting of 100 and full-scale vacuum at 0.

APPENDIX A

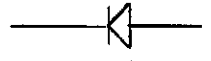
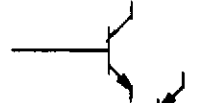
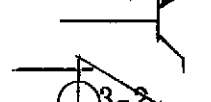
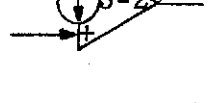
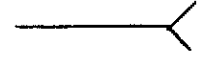
SYMBOLS AND NOMENCLATURE

	Capacitor
	Resistor
	Circuit common (cards no. 1 and 2 pin 30, card no. 3 pin 2)
	+15 volt supply (cards no. 1 and 2 pin 35, card 3 pin 1)
	-15 volt supply (card no. 3 pin 3)
	Diode, 1N458A
	Transistor, NPN, 2N3904
	Transistor, PNP, 2N3906
	1/4th of quad operational amplifier, LM3900 (pin 7 - common, pin 14 - +15) 3-2 indicates quad no. 3, amplifier no. 2
	Test jack
	Indicates card pin no. 23
	Indicates component pin no. 18
1-16	Indicates card no. 1 pin no. 16 (when not used inside op amp symbol)

APPENDIX B

SYSTEM SCHEMATICS

This appendix contains the detailed electrical and pneumatic schematics necessary for maintenance and checkout of the MVAS. The programmer circuit cards are shown in figures 14 through 19. Table II provides a list of the blocks from figure 4 and a tabulation of the active components on cards no. 1 and no. 2 in each block. Card no. 3 (figs. 18 and 19) contains the $\pm 15\text{v}$, 300 ma power supply for the programmer and two relays. The relays are used to multiply reference voltages V_1 and V_2 by heart rate for use in the double delay total artificial heart mode.

Figure 20 provides a schematic of the components mounted on the front panel of the programmer. A complete interconnection list is given in table III. Cable and connector diagrams are presented in figures 21 and 22.

The pneumatic schematic for the supply and monitoring panels is given in figure 23. Details of the switching valve box are shown in figures 24 and 25. The spool and fluidic interface valves were housed in a wooden box lined with acoustical tile to minimize noise.

REFERENCES

1. Webb, John A., Jr.; and Gebben, Vernon D.: Design and Performance of a Heart Assist or Artificial Heart Control System Using Industrial Pneumatic Components. NASA TM X-1953, 1970.
2. Gebben, Vernon D.; and Webb, John A., Jr.: Cardiac R-Wave Detector With Automatic Sensitivity Control. NASA TN D-7152, 1973.

TABLE I. - PROGRAMMER CIRCUIT TEST POINTS

Signal	Test jack color	Signal description
A	Blue	Triangle wave
B	Yellow	Ventricle drive
C	Grey	Outflow valve drive
D	Black	Inflow valve drive
E	Green	Trigger mono output
F	White	Delay mono output
G	Red	Duration mono output

TABLE II. - ASSIGNMENT OF ACTIVE COMPONENTS

Card	Block (from fig. 4)	Active components
	Triangle wave osc	1-1, 1-2, T1
	Vent comparator	2-2
	R-wave comparator	1-4
1	S1 logic	3-1, 3-2, 3-3, 3-4, T3, T4, T5, T6
	Vent drive amp	T-7
	Outflow valve timing comparator	2-3
	Inflow valve timing comparator	2-4
	Outflow drive amp	T-8
	Inflow drive amp	T-9
	Trig mono	4-1, 4-2, T10
	Counter	MC663P
2	Mono 1	5-1, 5-2, 5-3, 5-4
	Mono 2	6-1, 6-2, 6-3, 6-4
	Outflow valve timing flip-flop	4-3
	Inflow valve timing flip-flop	4-4

TABLE III. - PROGRAMMER CIRCUIT INTERCONNECTIONS

Pin no.	Card no. 1	Card no. 2	Card no. 3
1	panel-heart rate pot wiper	panel-ext sync phono jack	1-35, 2-35 (+15)
2	panel-heart rate pot	panel-counter switch 1:1	1-30, 2-30 (common)
3	panel-ext H.R. phono jack, 3-6	panel-sync lite (clear)	(-15)
4	panel-ext H.R. phono jack	1-10, 2-21	
5		panel-outflow valve delay toggle switch	1-16
6	panel-sync out jack	1-9, 2-12	1-3
7	panel-percent systole pot	panel-inflow valve delay toggle switch	2-25
8	panel-percent systole pot wiper	panel-counter switch 1:2	2-26
9	2-12, 2-6	panel-counter switch 1:4	panel-delay selector switches
10	2-21, 2-4	panel-delay decade	panel-outflow valve delay toggle switch
11	2-11, panel-delay decade	1-11, panel-delay decade	panel-inflow valve delay toggle switch
12	output drive-outflow valve	1-9, 2-6	
13	2-18, panel-duration decade	1-32, 2-20	
14	output drive-inflow valve	1-33, 2-19	
15	panel-P.B. red	panel-counter sw. wiper	
16	panel-red lite, 3-5		
17	panel-P.B. blue	panel-duration decade	
18	panel-blue lite	panel-duration decade, 1-13	
19	panel-P.B. yellow	1-33, 2-14	
20	panel-yellow lite	1-32, 2-13	
21	panel-P.B. green	1-10, 2-4	
22	panel-green lite		
23	R-wave det. -minus input of A13	1-25	
24	R-wave det. -sensitivity output of A13		
25	2-23	3-7, duration ref. voltage	
26	output drive-ventricle, panel-yellow systole lite	3-8, delay ref. voltage	
27	panel-outflow valve delay toggle switch		
28	panel-inflow valve delay toggle switch		
29	panel-outflow valve delay toggle switch		
30	2-30, 3-2, common	1-30, 3-2, common	
31	panel-inflow valve delay toggle switch		
32	2-13, 2-20		
33	2-14, 2-19		
34	panel-audible alarm		
35	2-35, 3-1, +15 volts	1-35, 3-1, +15 volts	

110 VAC
third wire ground

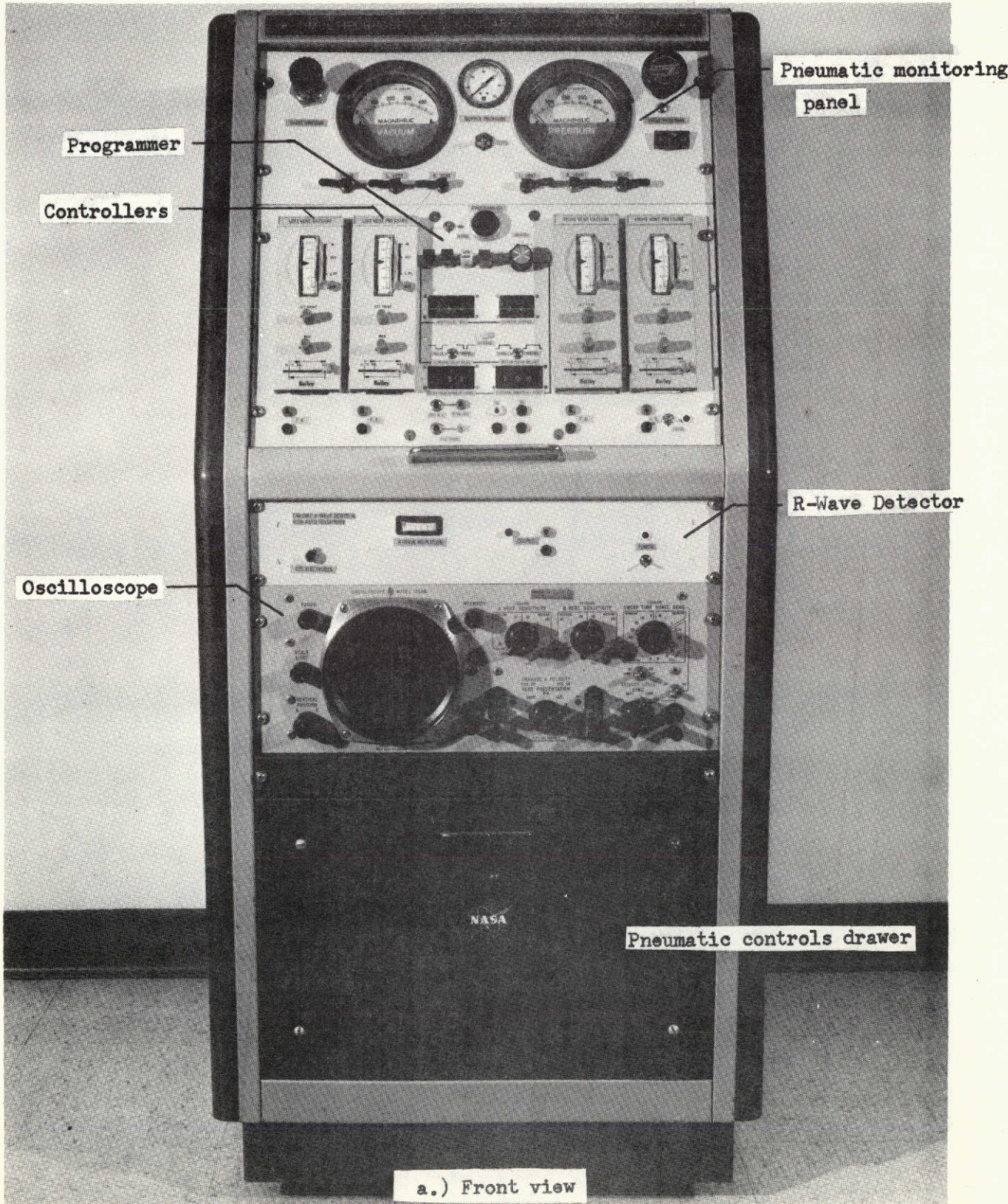

Figure 1. - Multipurpose Ventricular Actuating System Console.

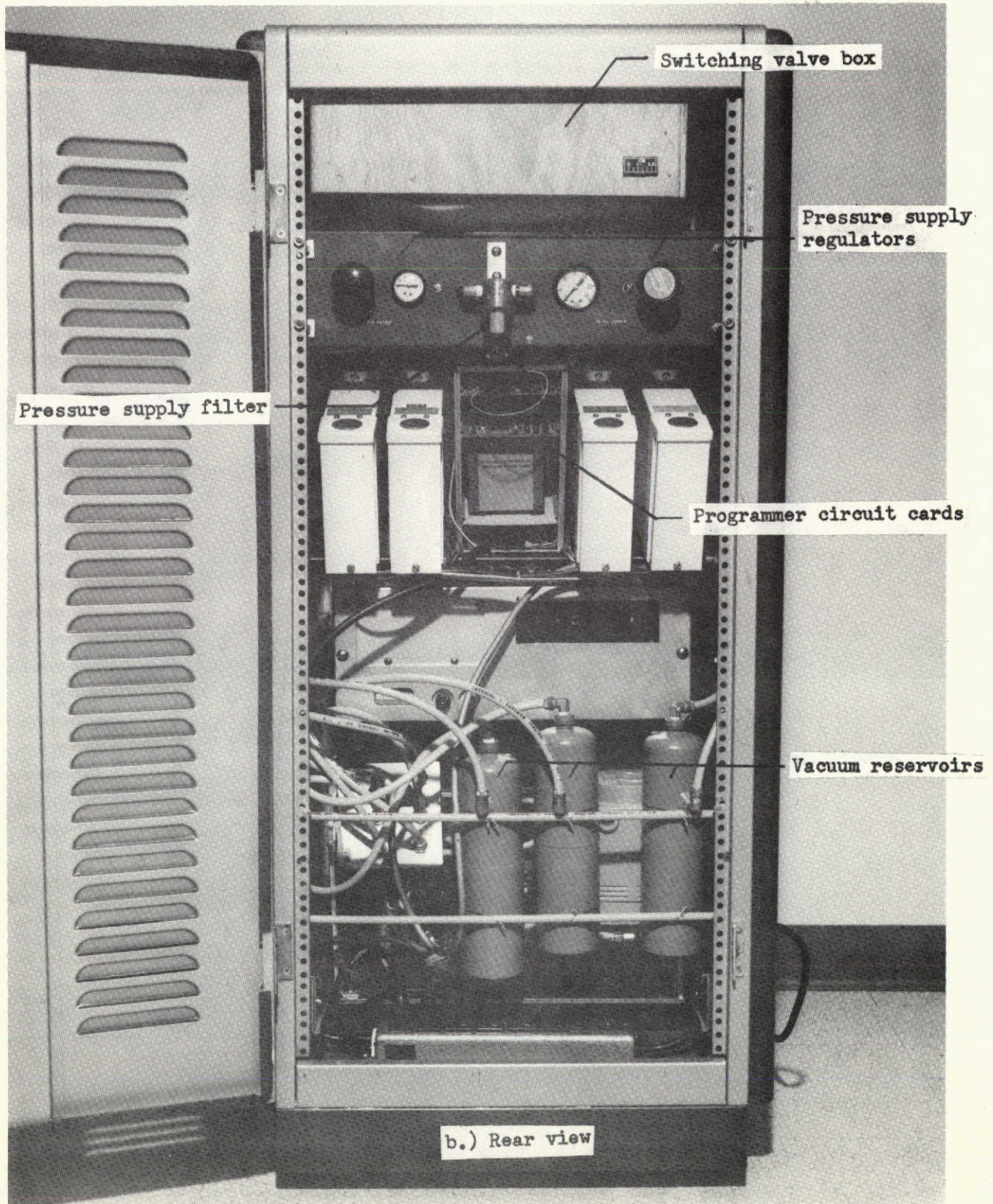
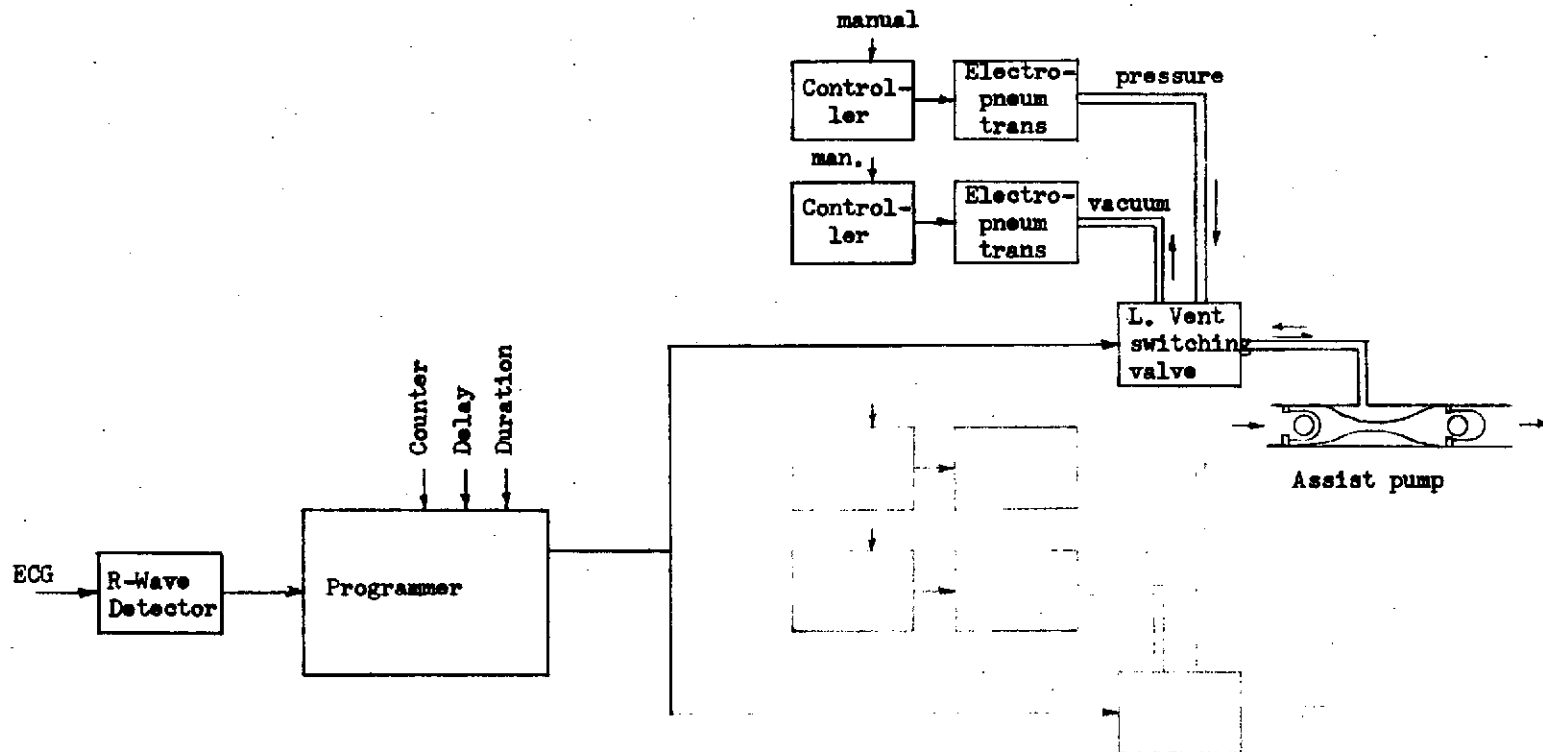
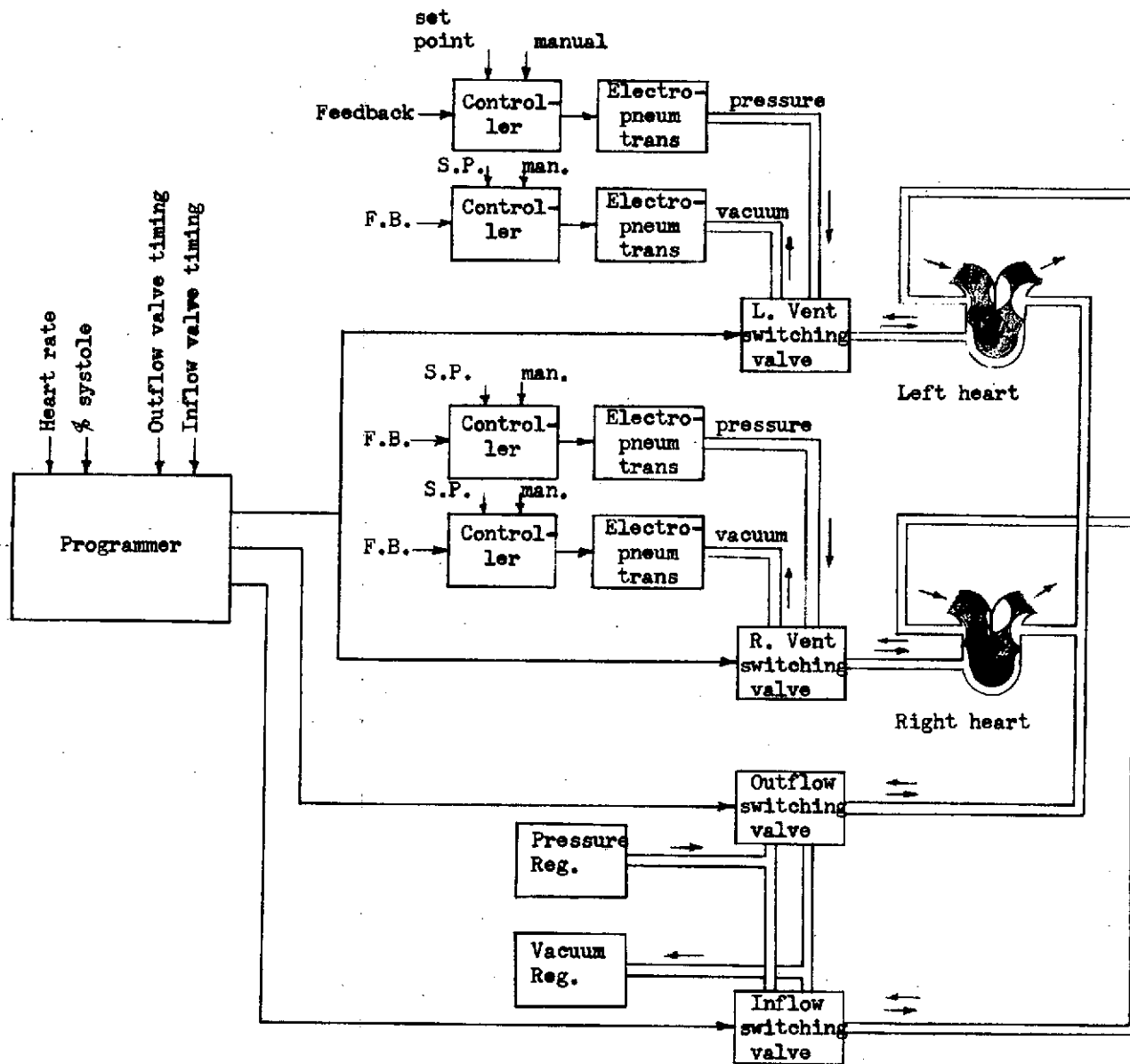

Figure 1. - Continued.



a.) Assist mode

Figure 2. - Overall diagram of functional usage of MVAS.



b.) Total artificial heart mode.

Figure 2. - Continued.

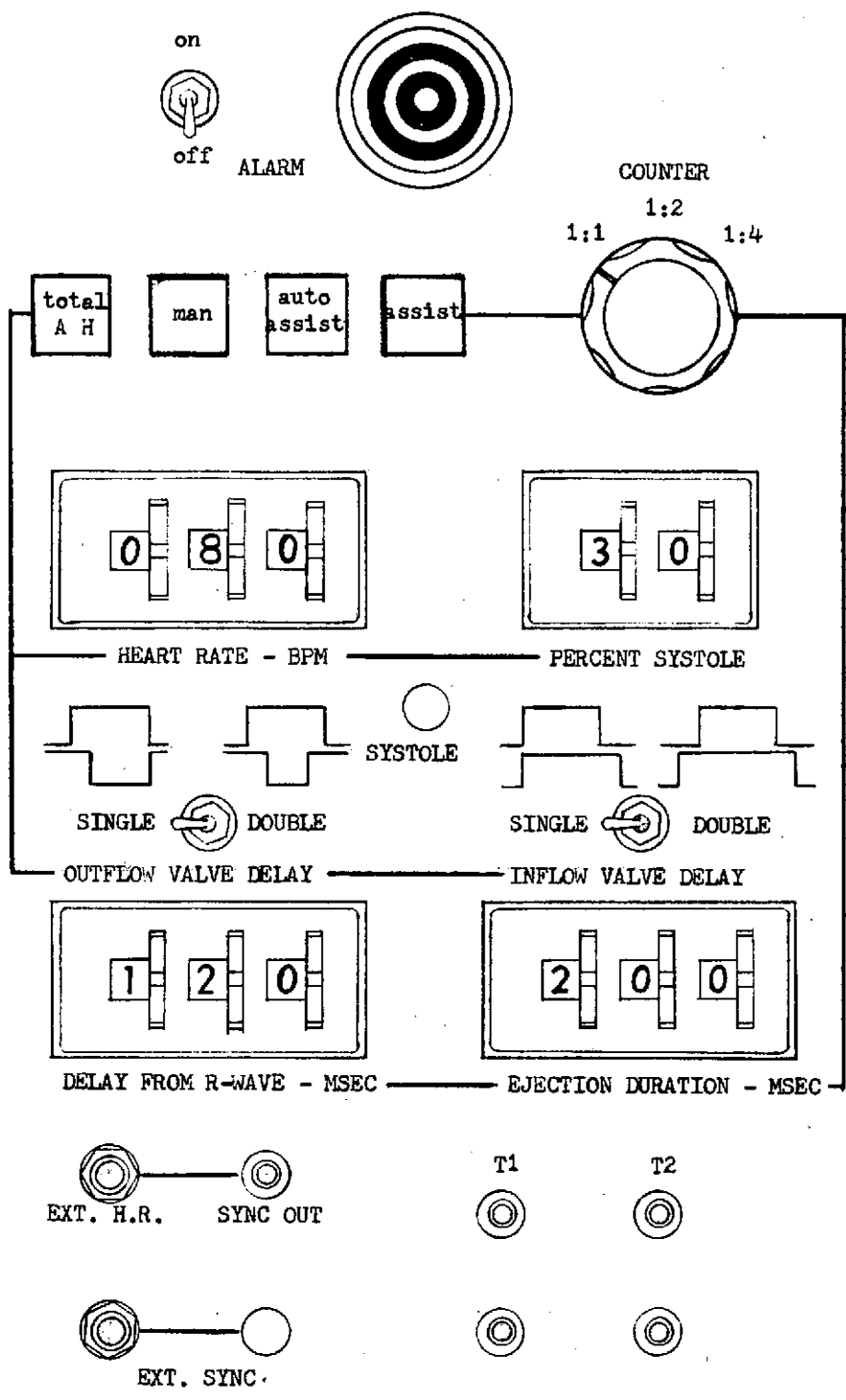

Figure 3. - Programmer panel layout.

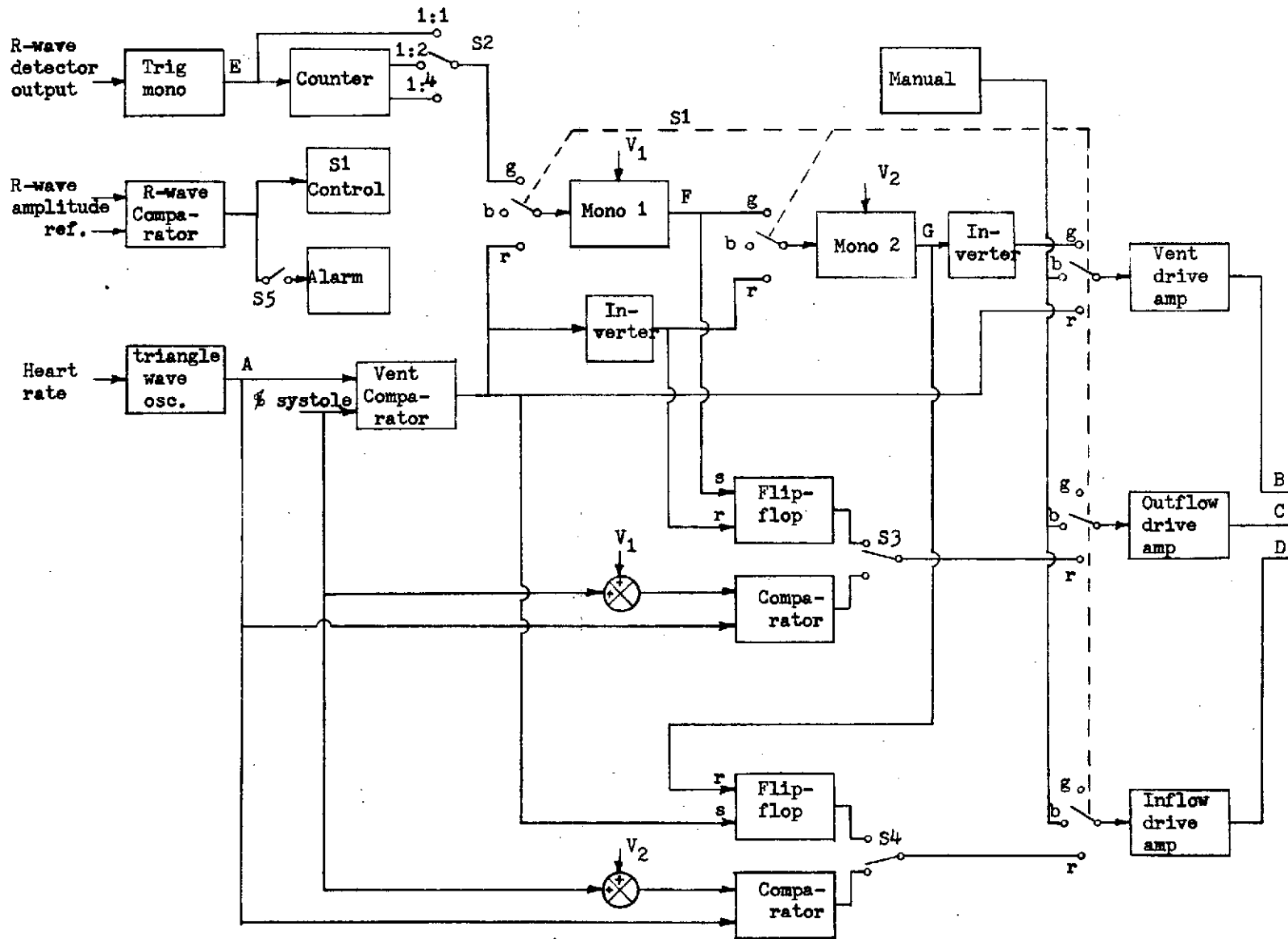
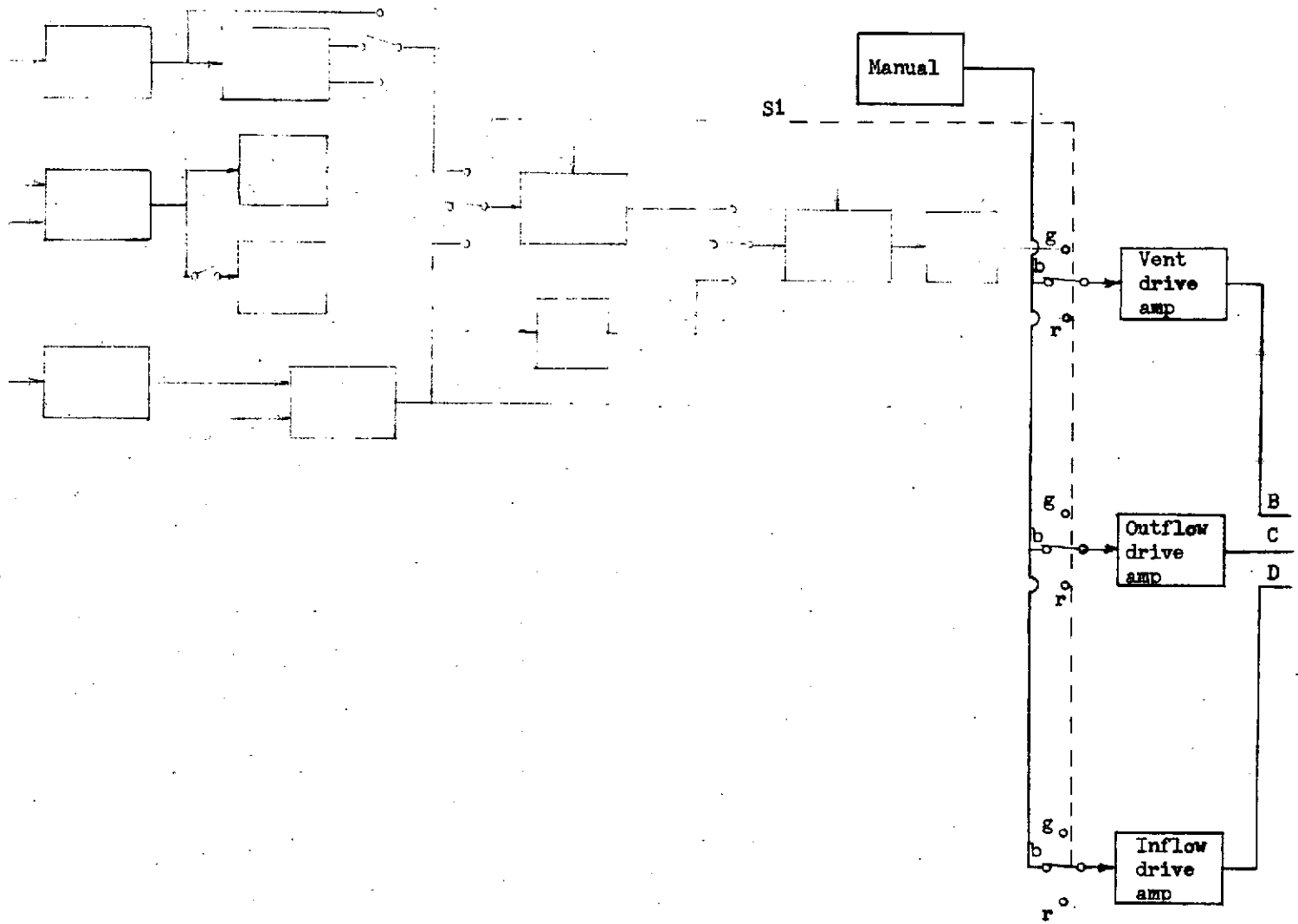

Figure 4. - Programmer block diagram.

BY DATE
 CHRD. BY DATE
 SUBJECT
 SHEET NO. OF
 JOB NO.



a.) Manual mode

Figure 5. - Programmer block diagram for various modes of operation.

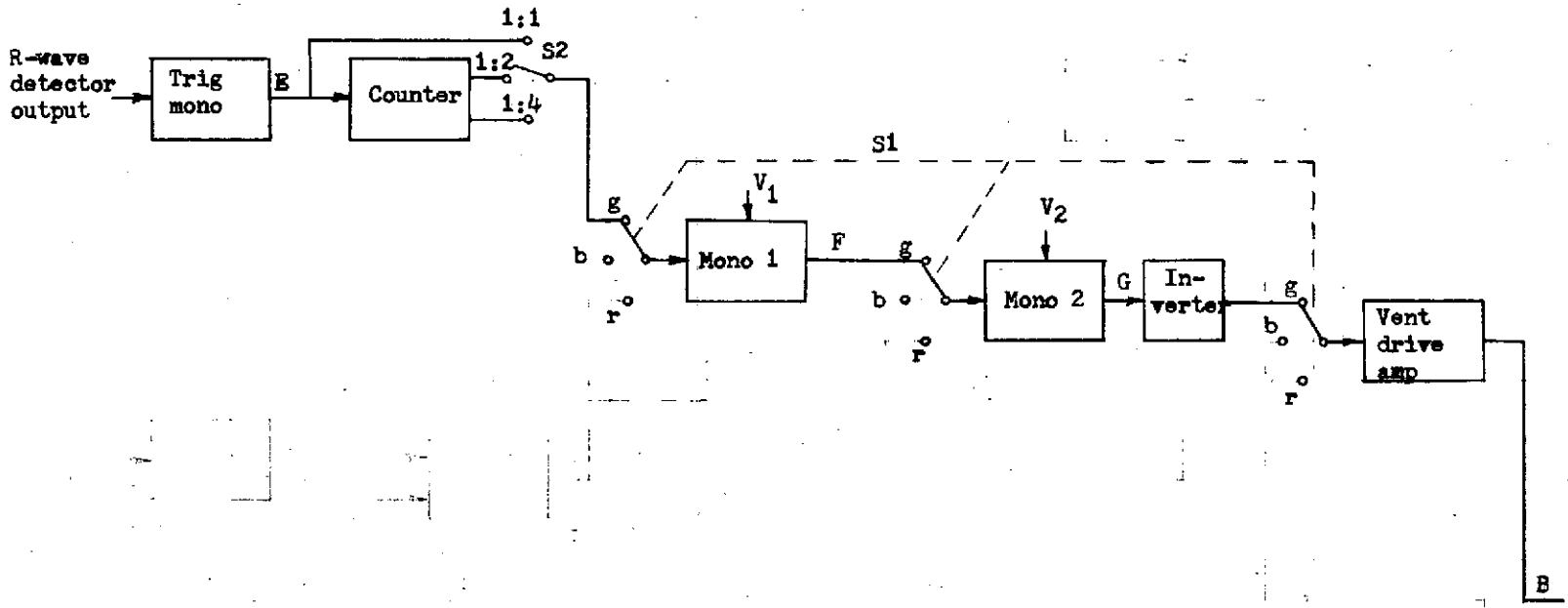

b.) Assist mode

Figure 5. - Continued.

BY DATE
 CHKD. BY DATE
 SUBJECT
 SHEET NO. OF
 JOB NO.

0/10

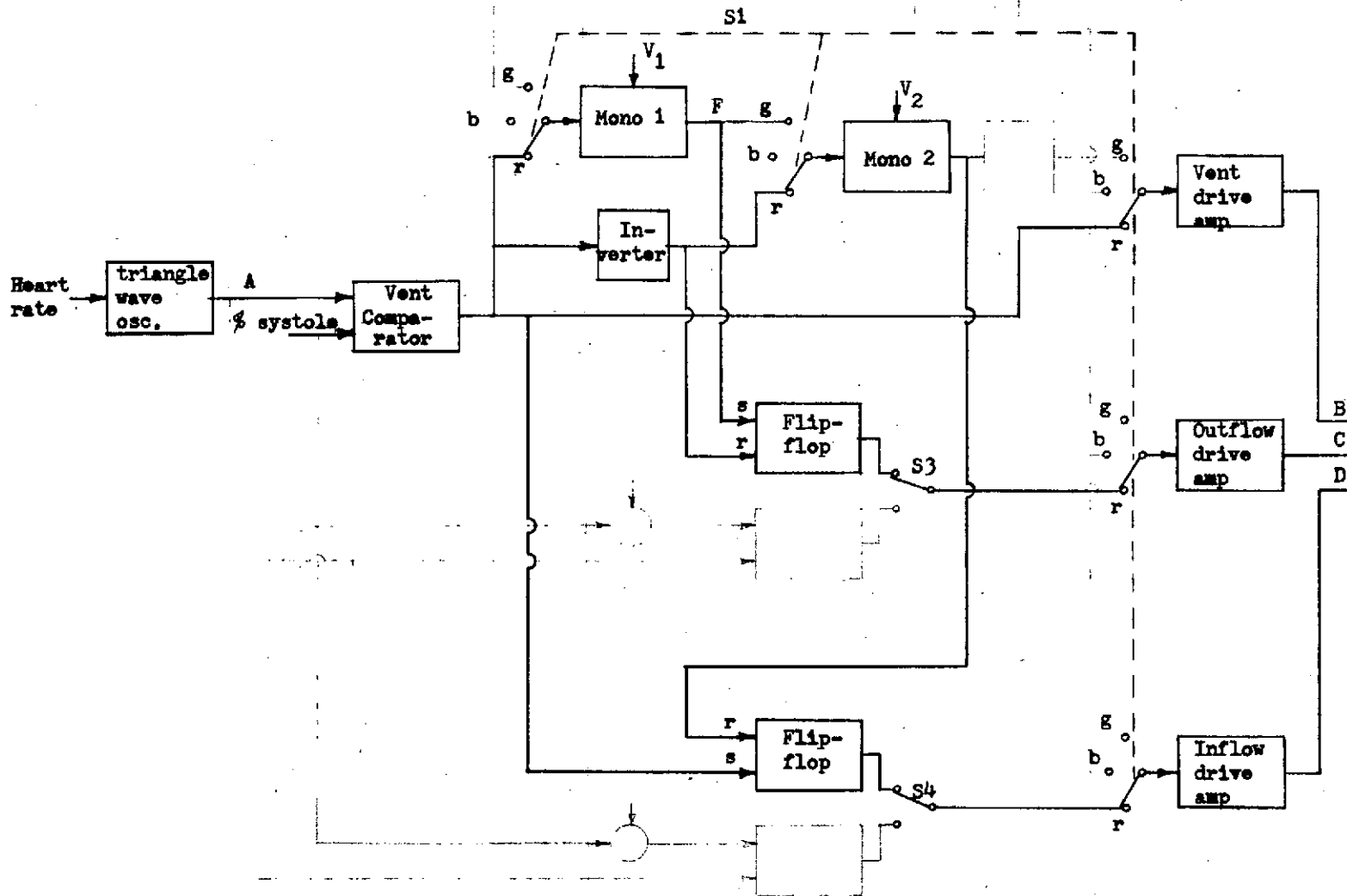

c.) Total Artificial Heart mode with single valve delays
 Figure 5. - Continued.

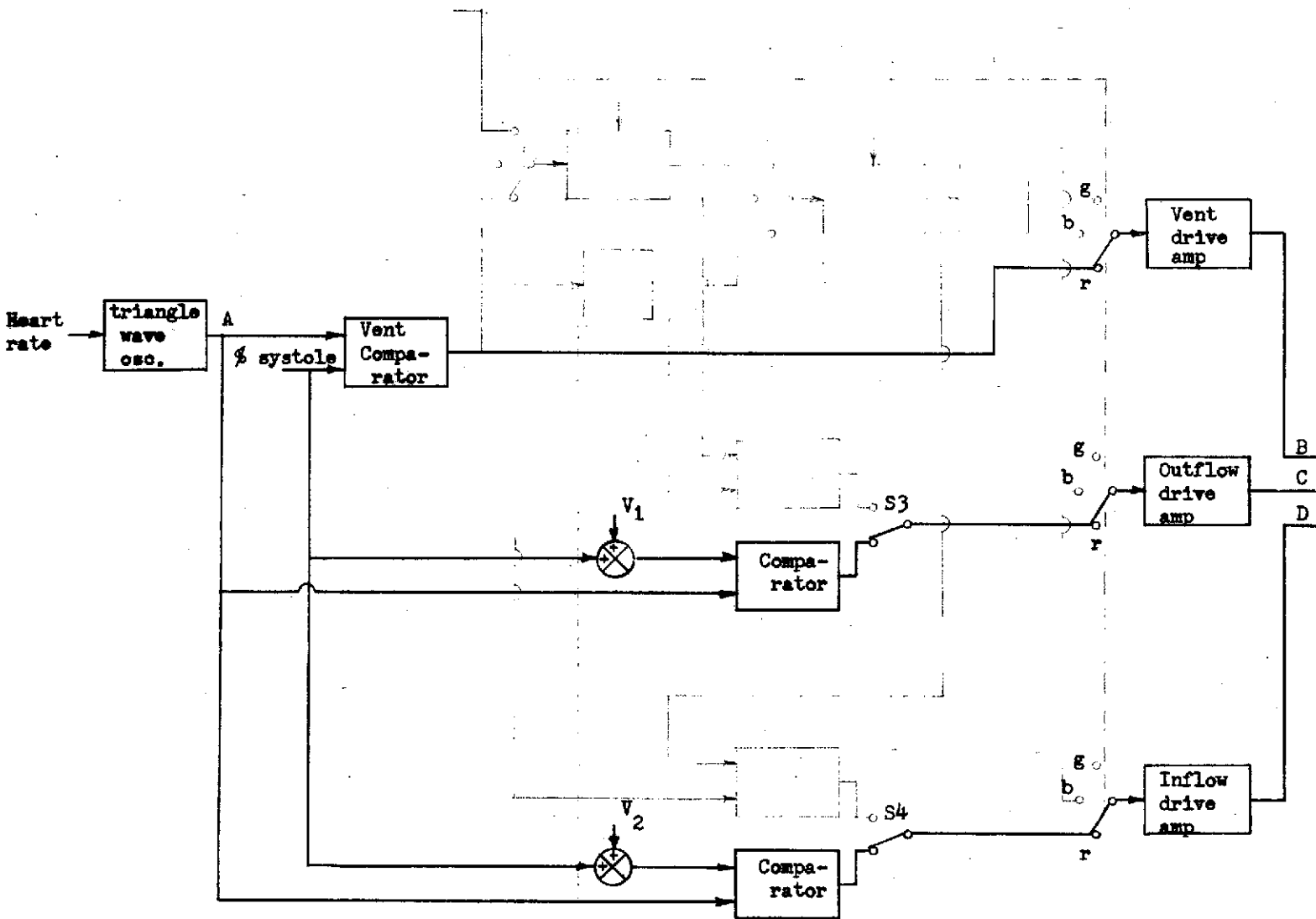

d.) Total artificial heart mode with double valve delays

Figure 5. - Continued.

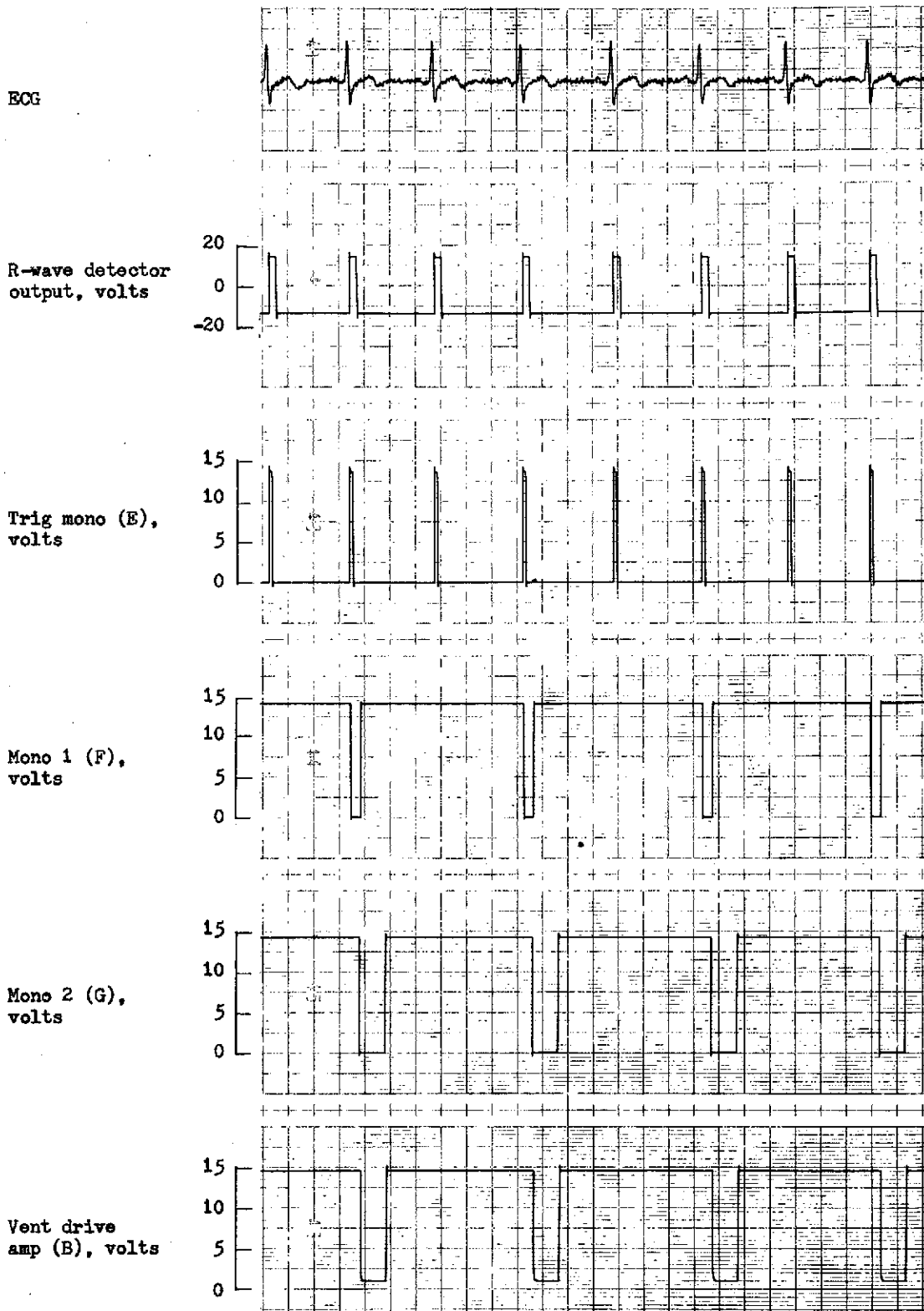

a.) Assist mode

Time → (200 msec/DIV)

Figure 6. - Typical programmer output signals.

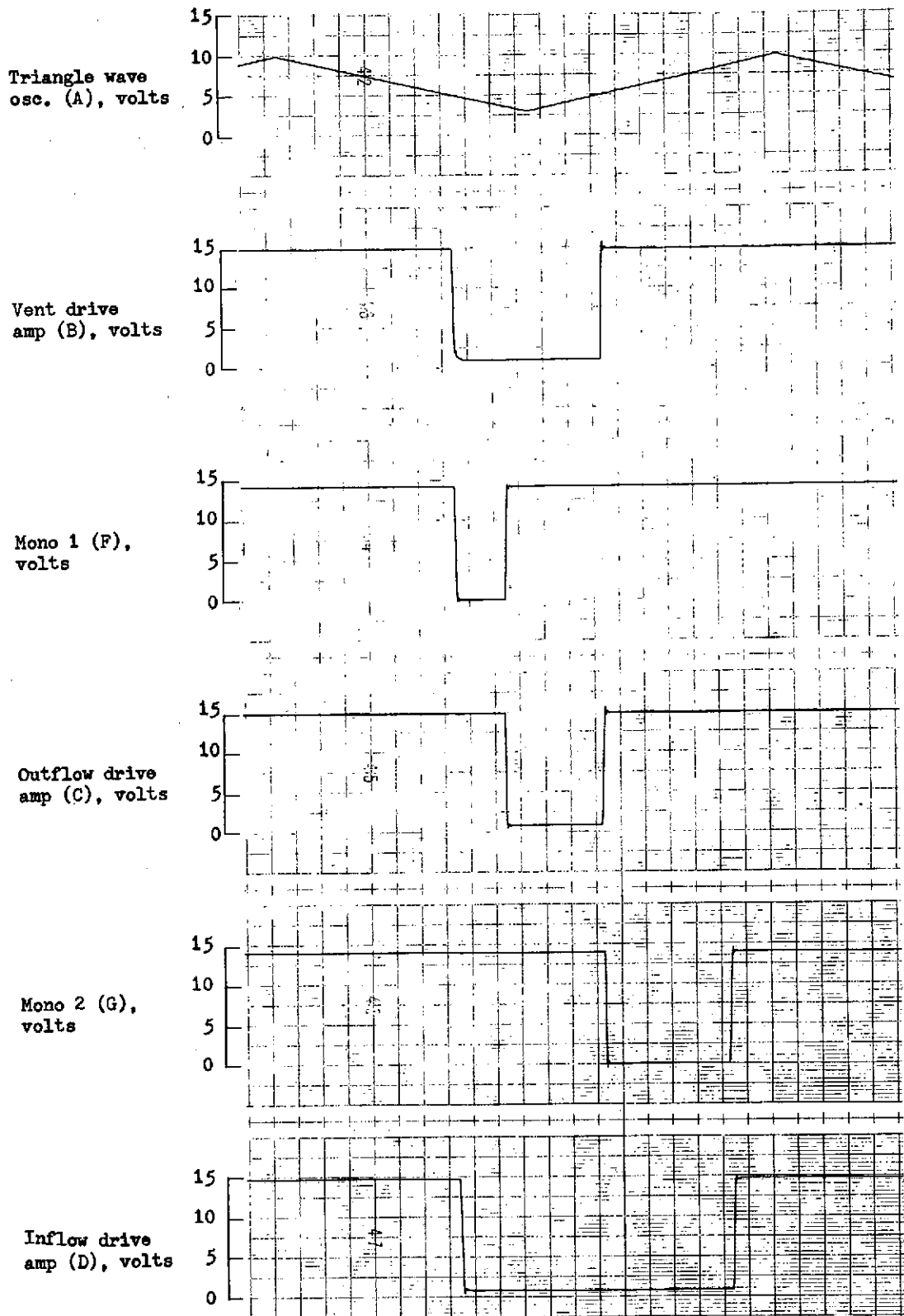

b.) Total A.H. with single delays Time → (50 nsec/DIV)

Figure 6. - Continued.

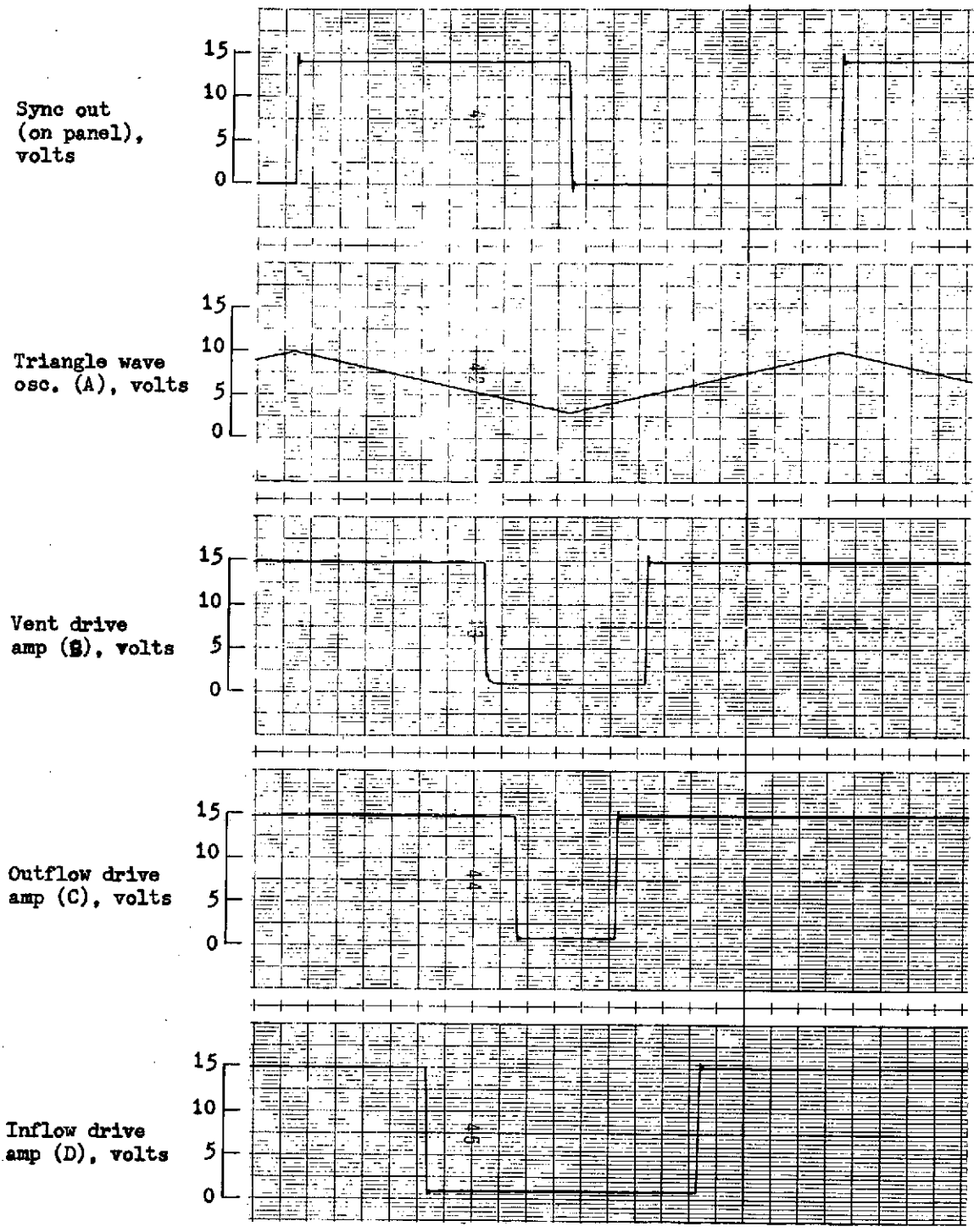

c.) Total A.H. with double delays Time → (50 msec/DIV)

Figure 6. - Continued.

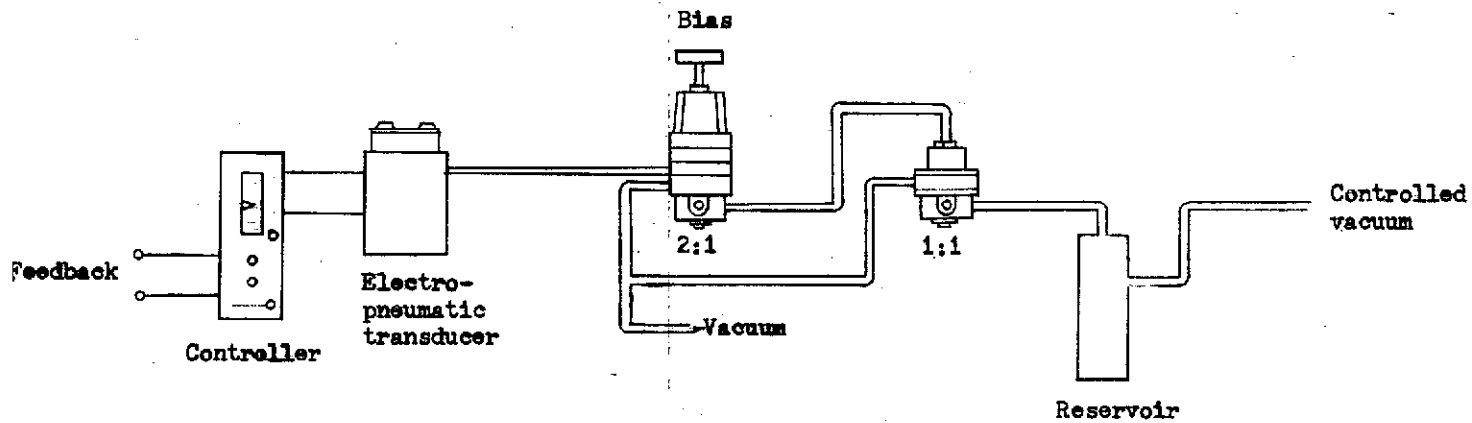
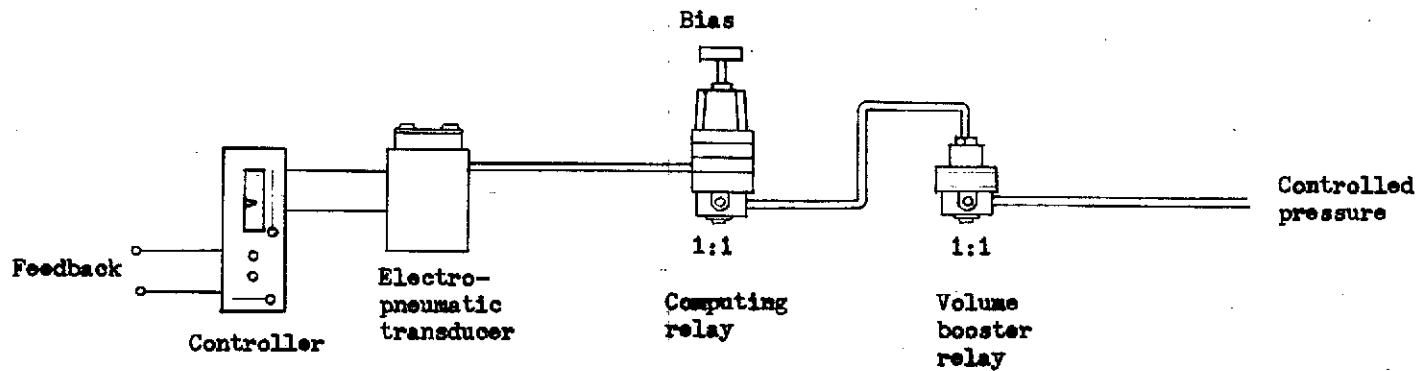
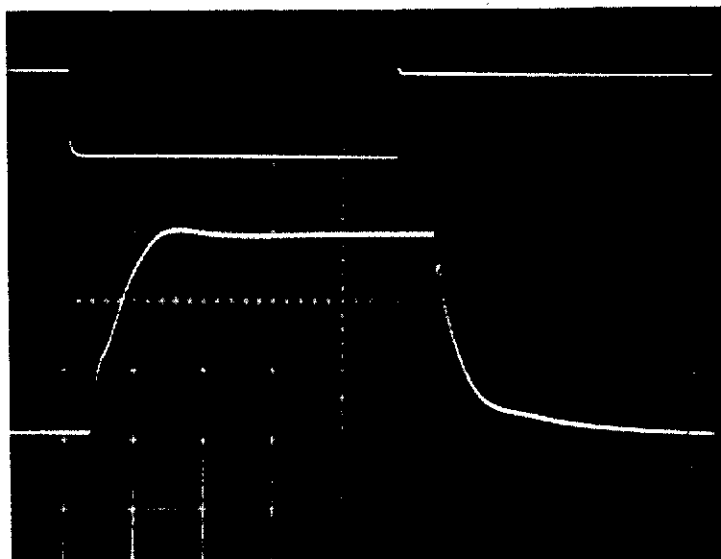
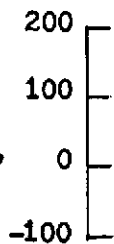

Figure 7. - Diagram of pressure and vacuum controls.

Vent drive
amp (B)

Left ventricle
driving pressure,
mm Hg



Time → (50 msec/DIV)

a.) 25 cm drive line

Vent drive
amp (B)

Left ventricle
driving pressure,
mm Hg

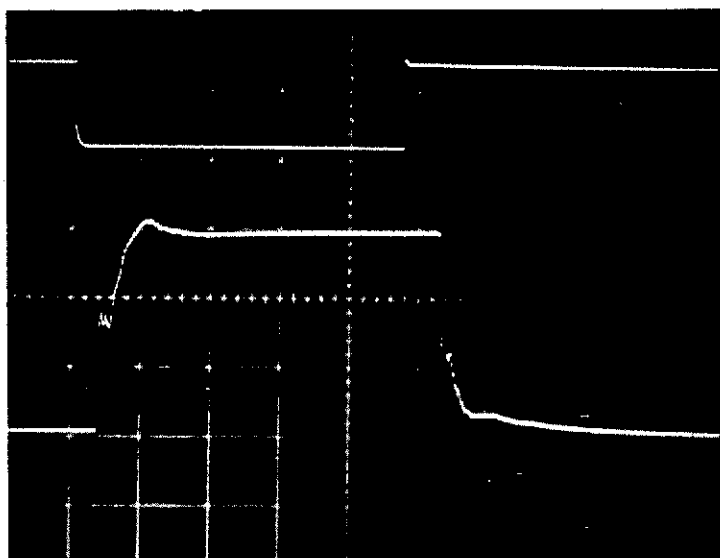
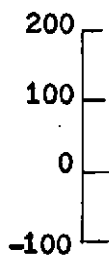

Time → (50 msec/DIV)

b.) 250 cm drive line

Figure 8. - Pneumatic switching valve response.

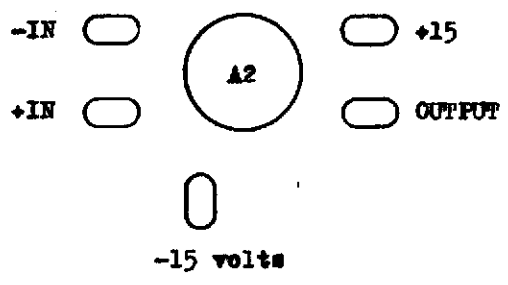

Figure 9. - Amplifier terminal arrangement for E-wave detector circuits.

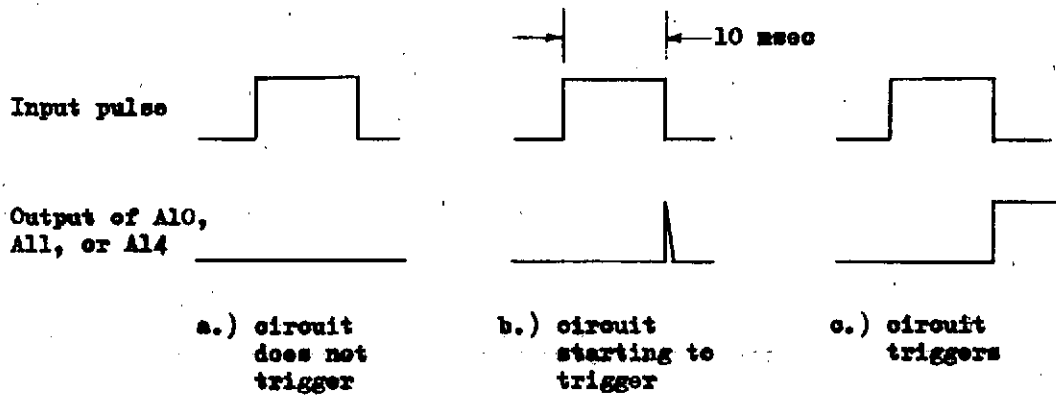

Figure 10. - Example of waveforms for adjusting pulse-width discriminator.

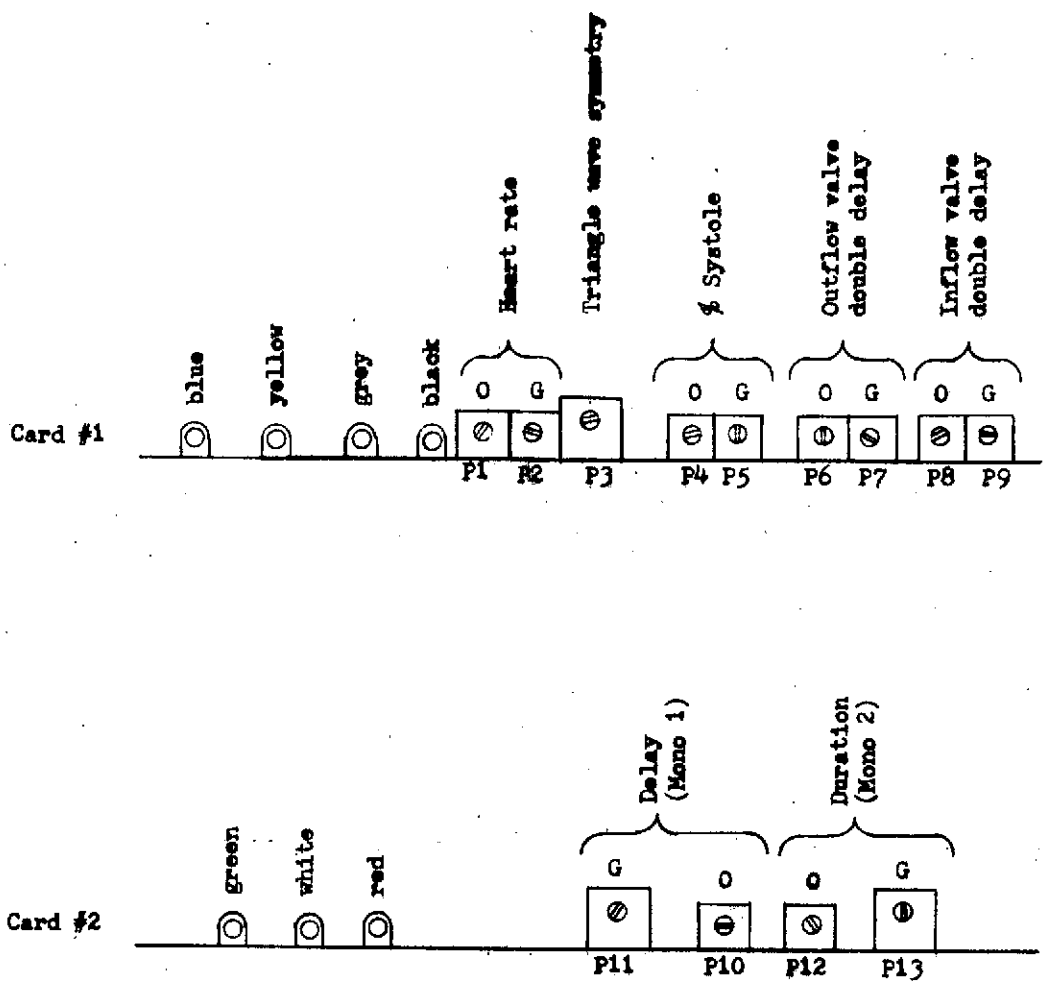
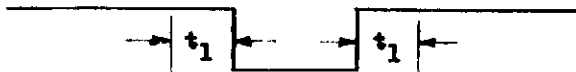

Figure 11. - Programmer trim pot locations.

yellow
(vent drive)



grey
(outflow valve)



black
(inflow valve)



Figure 12. - Double delay timing waveforms.

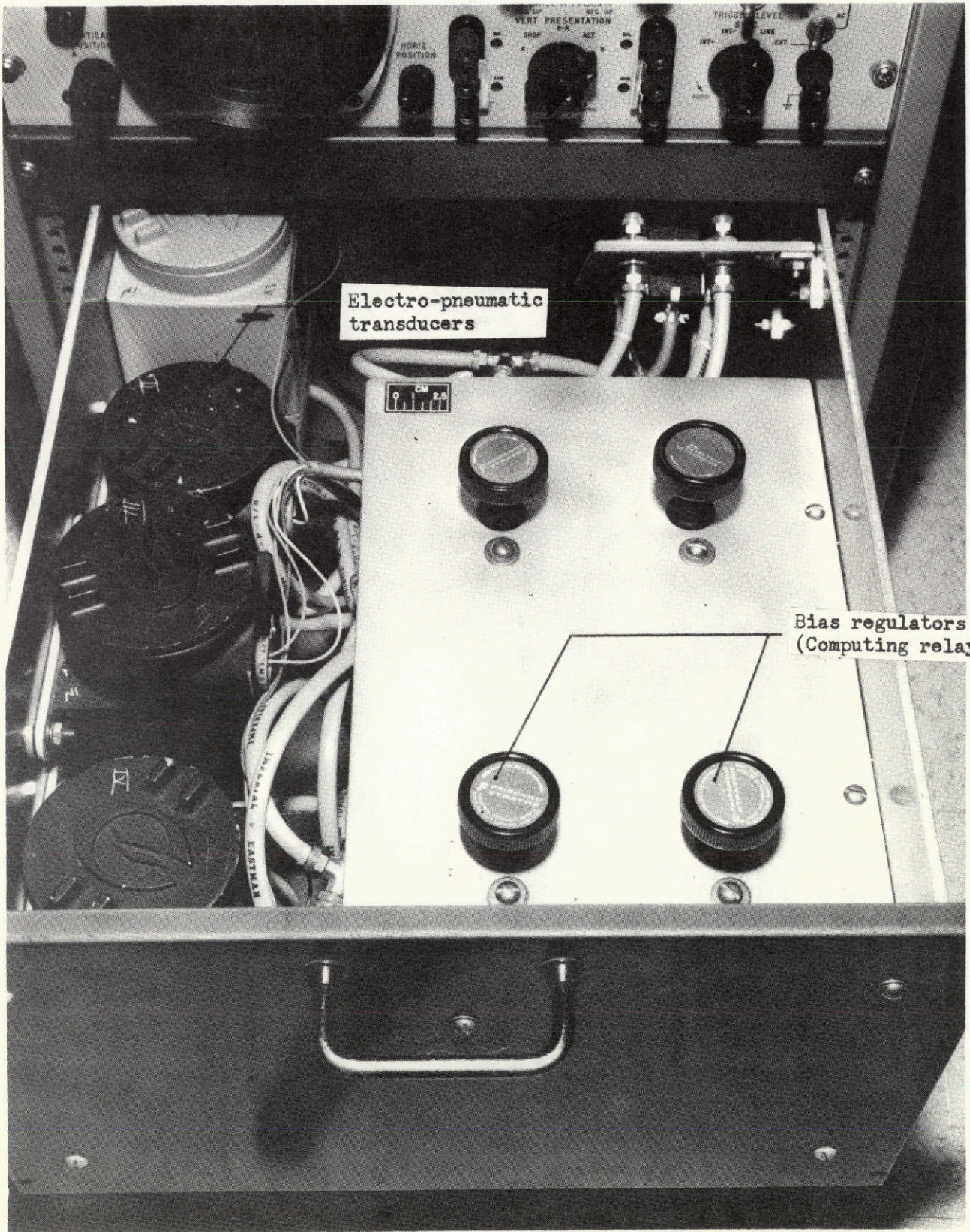

Figure 13. - Pneumatics controls drawer.

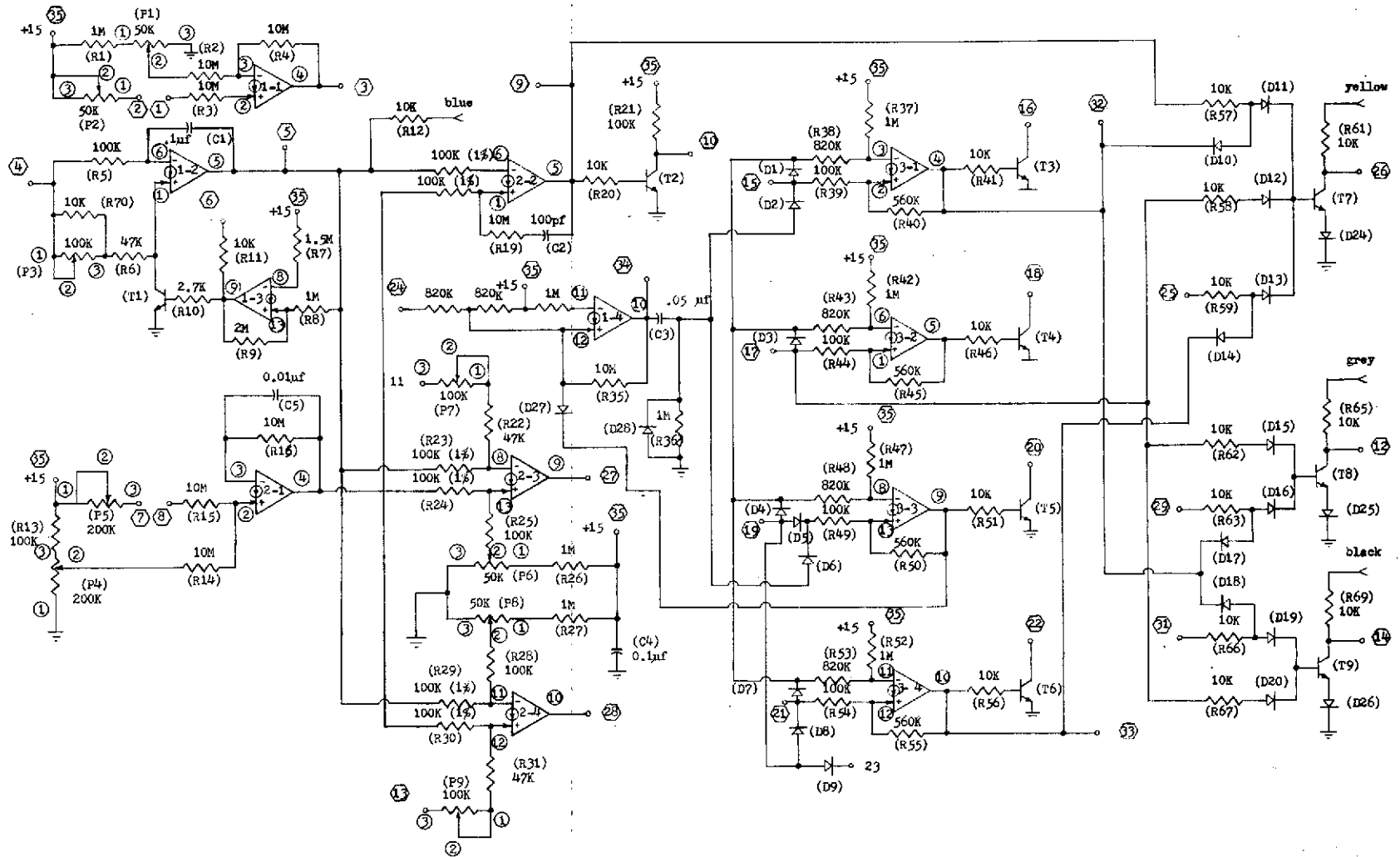

Figure 14. - Schematic diagram of programmer card #1.

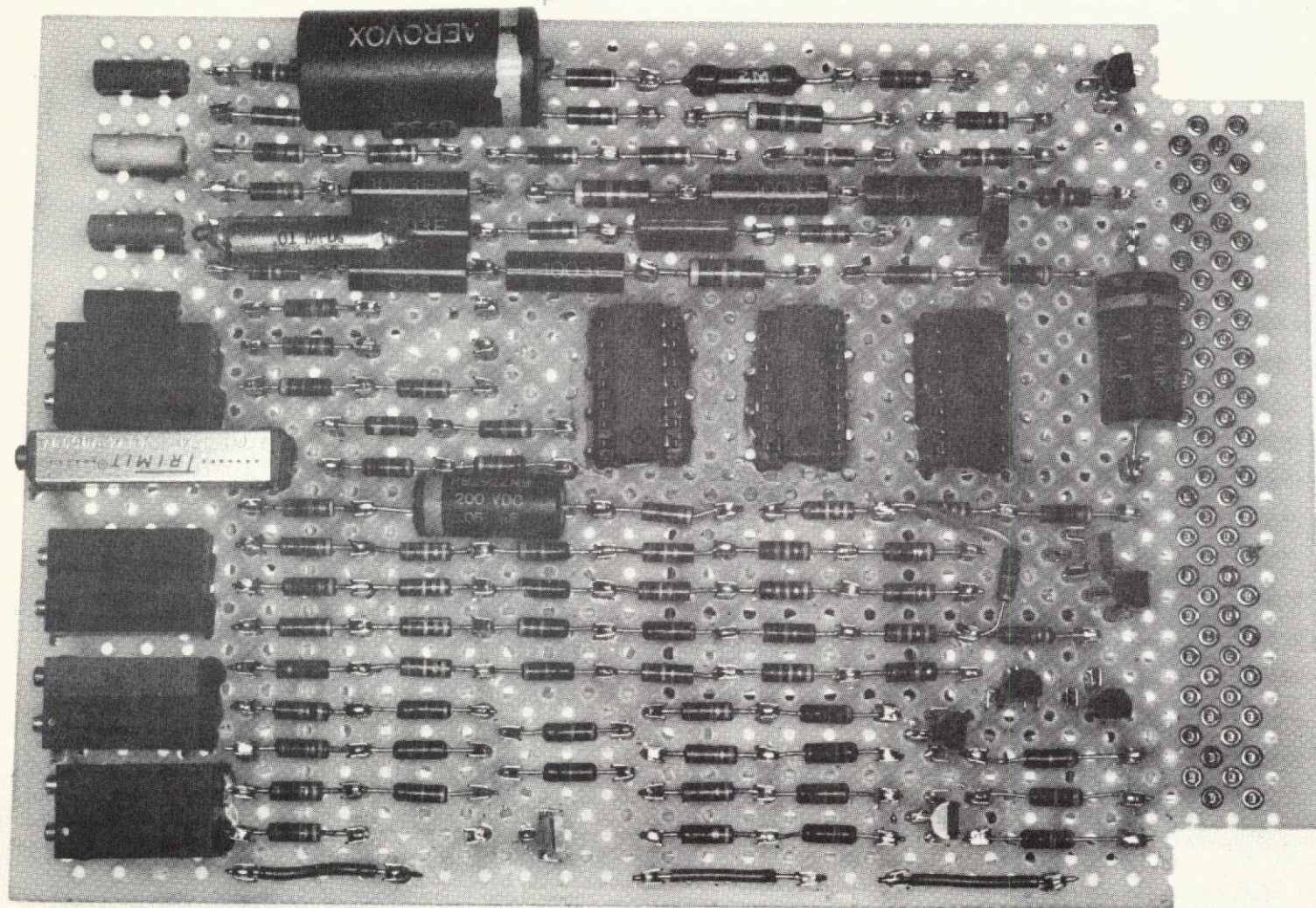

Figure 15. - Layout of programmer card #1.

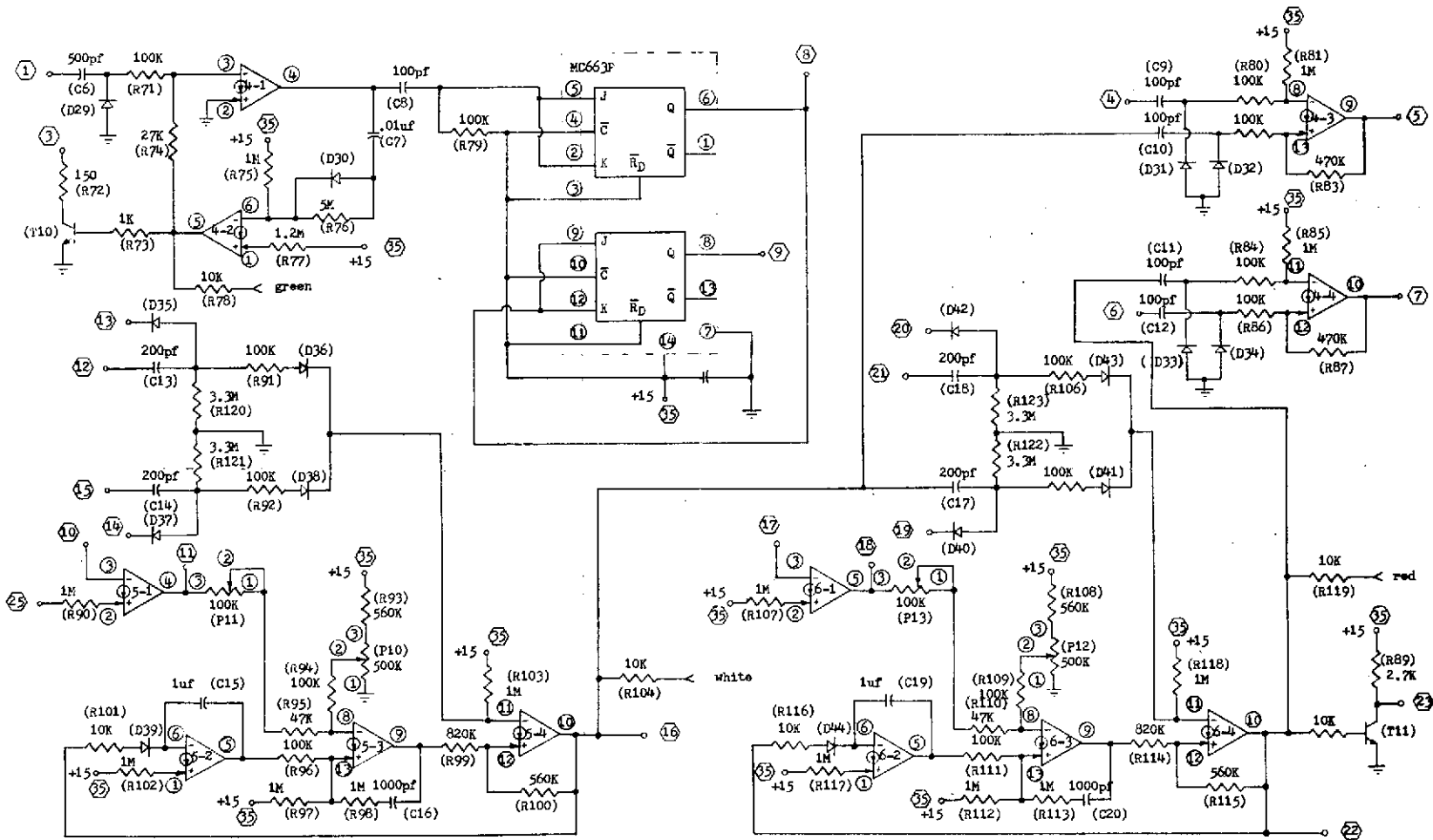

Figure 16. - Schematic diagram of programmer card #2.

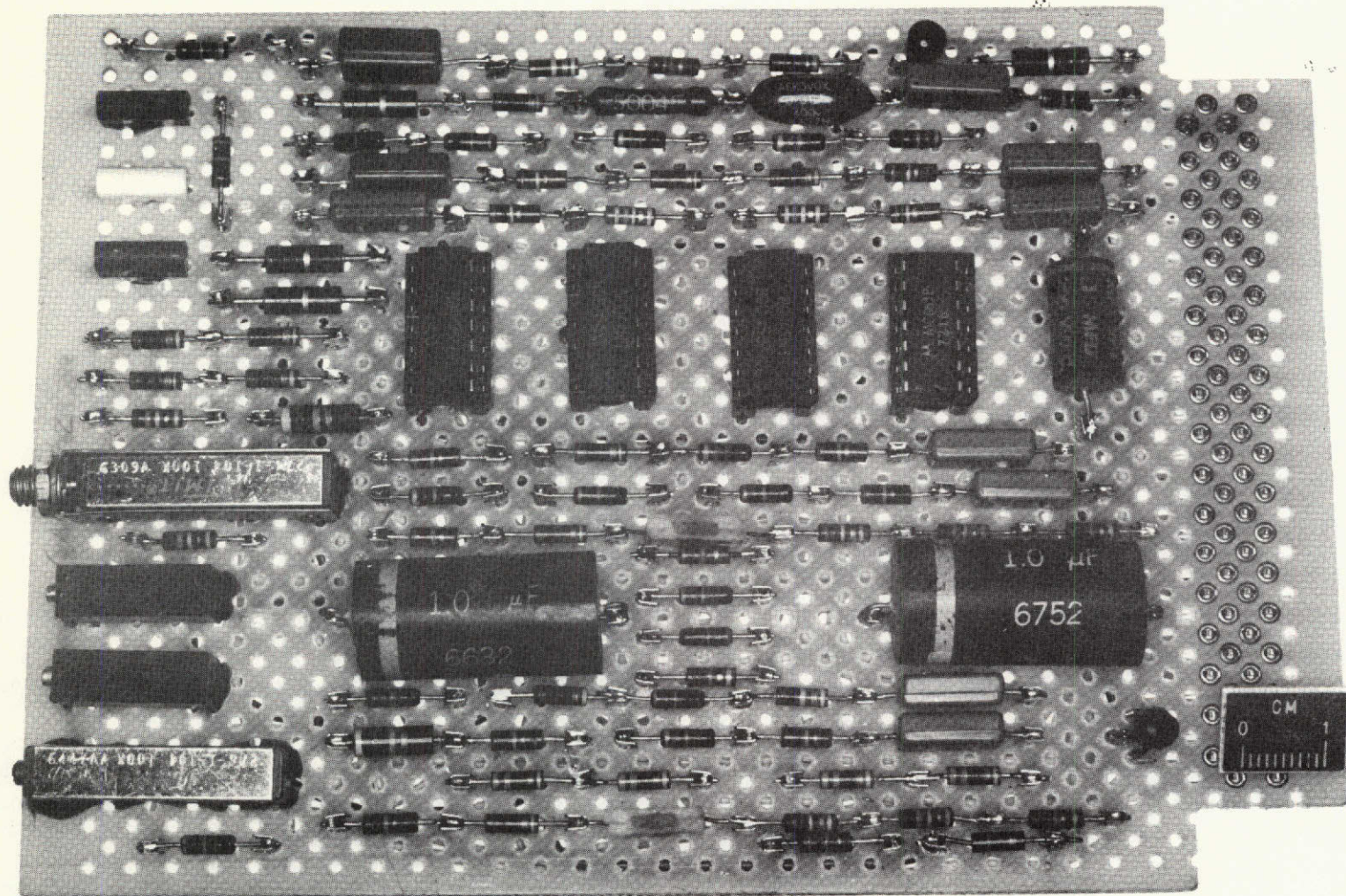

Figure 17. - Layout of programmer card #2.

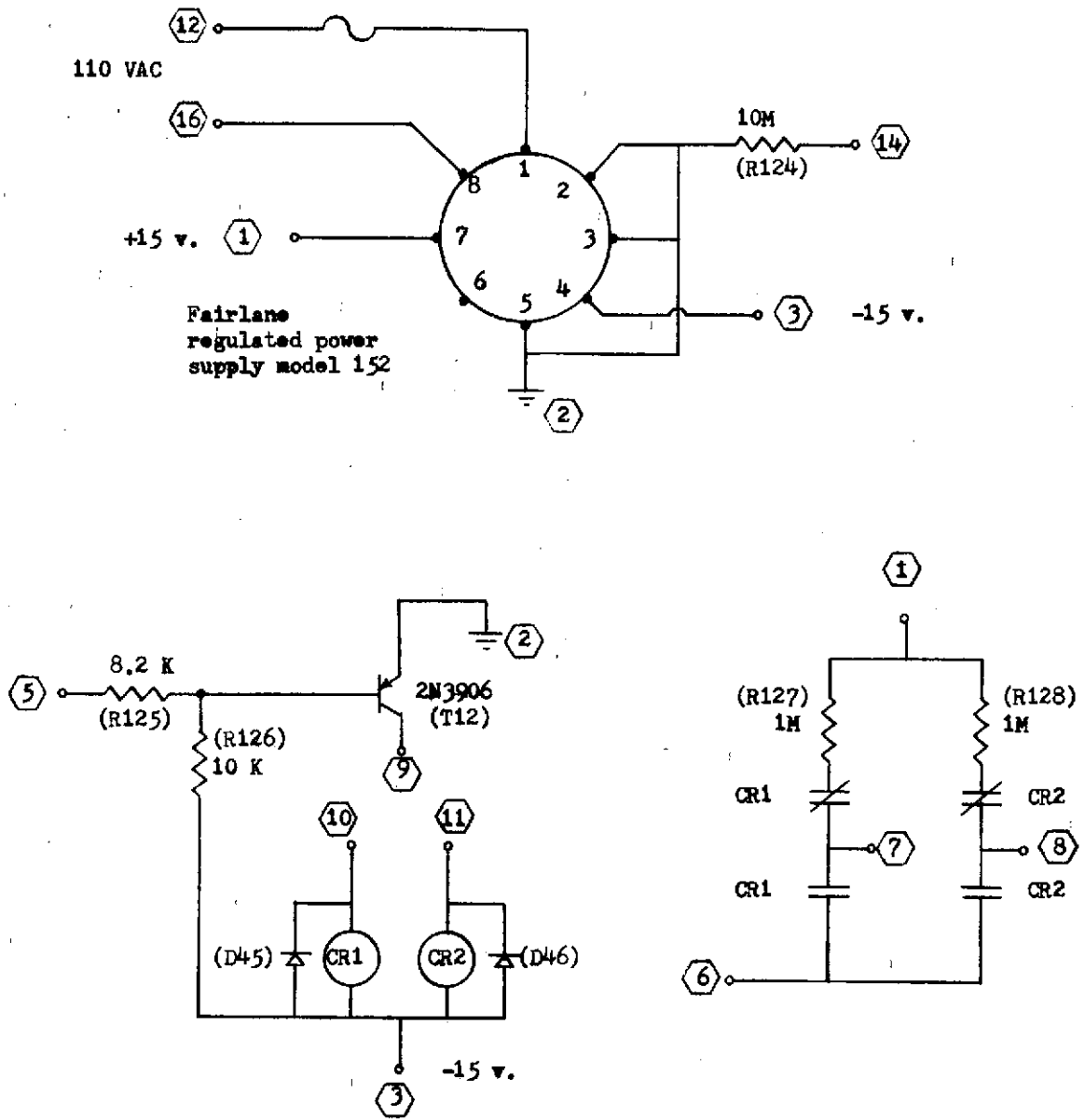
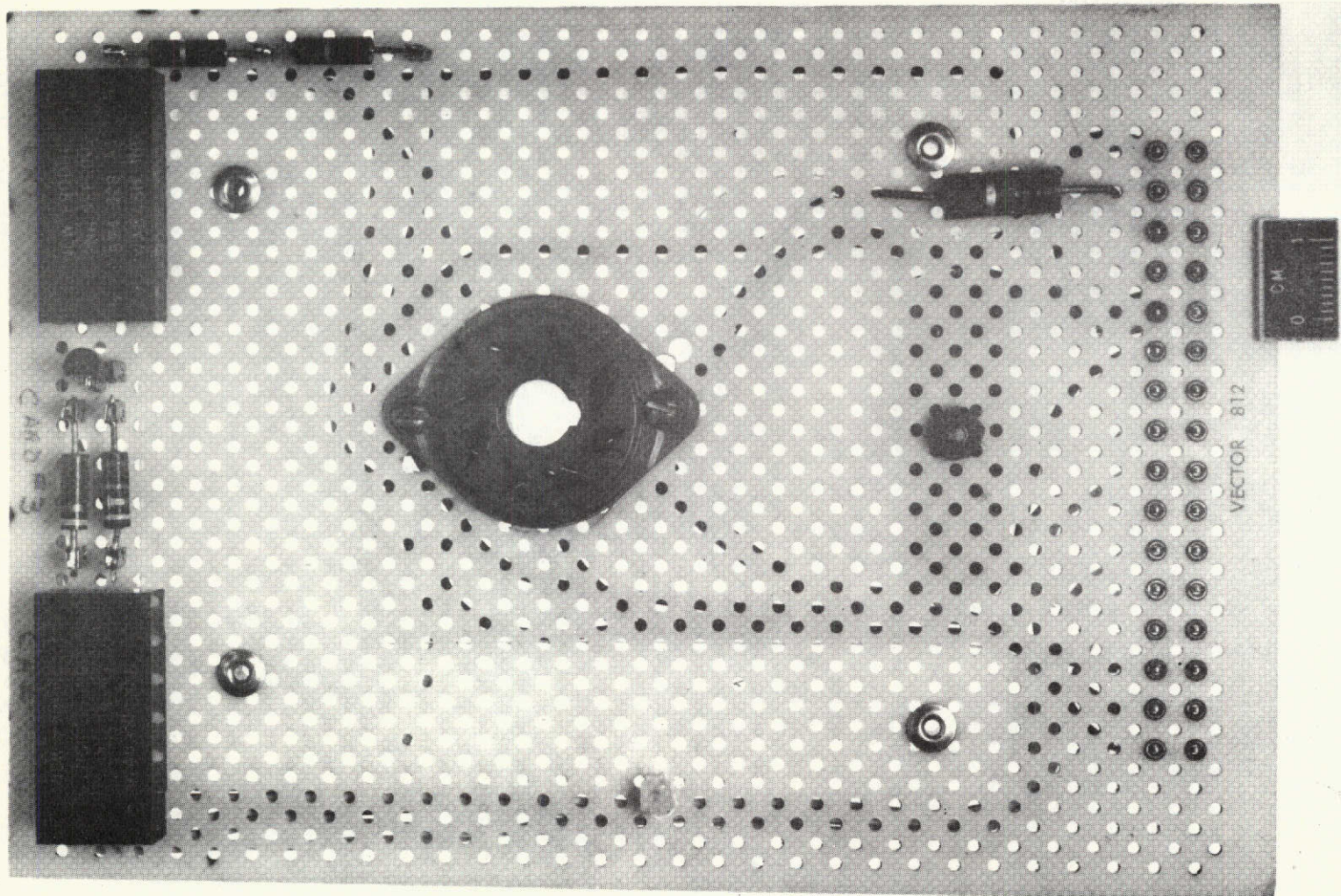
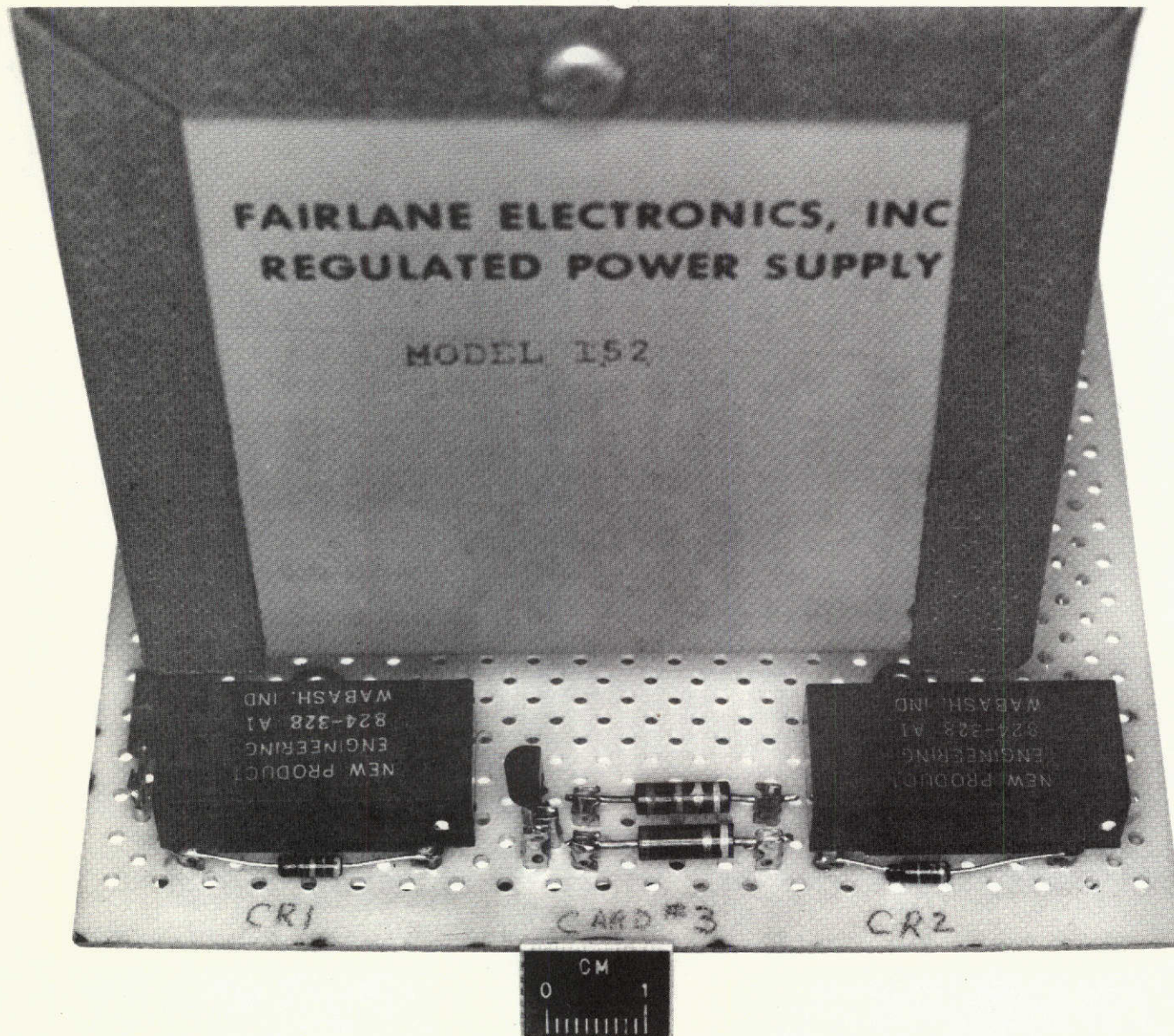

Figure 18. - Schematic diagram of programmer card #3.



a.) Without power supply

Figure 19. - Layout of programmer card #3.



b.) With power supply.

Figure 19. - Continued.

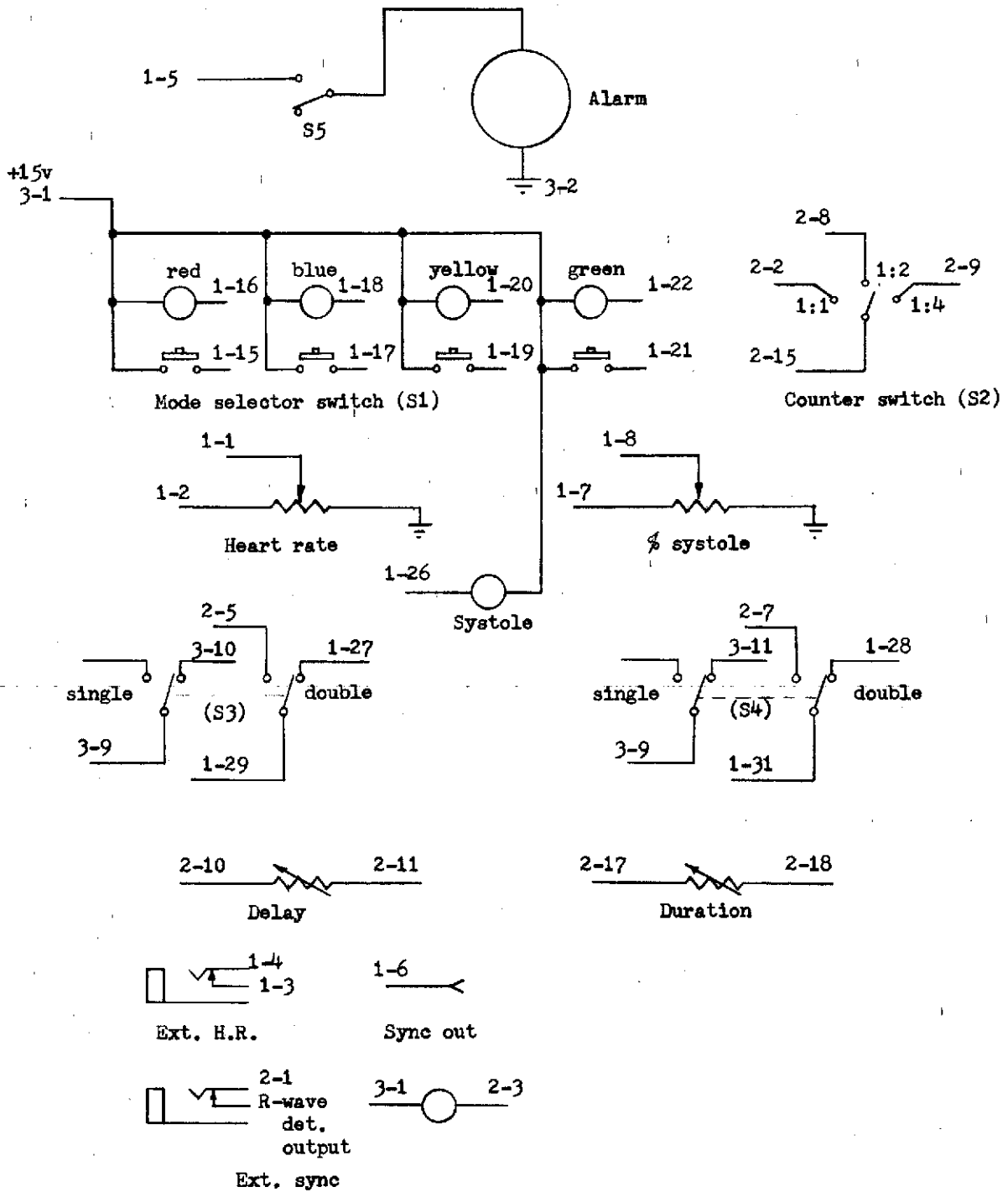

Figure 20. - Programmer panel wiring schematic.

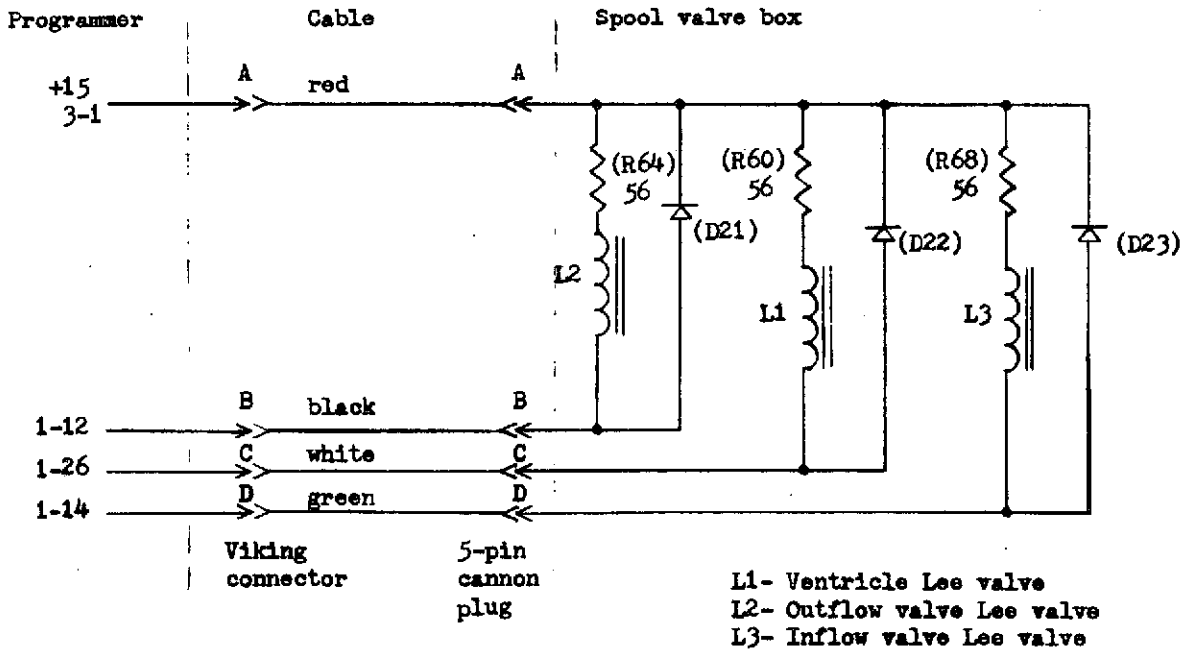
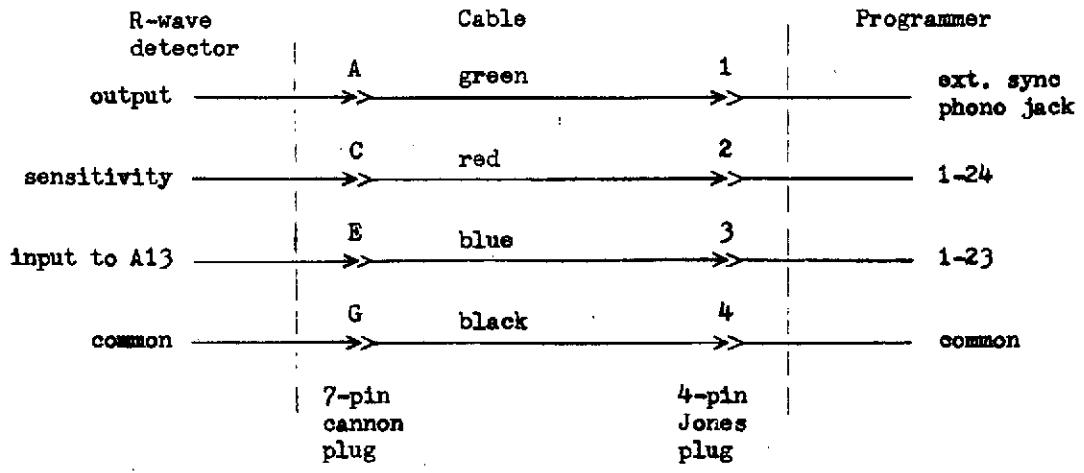

Figure 21 - Schematic of programmer connectors and cables.

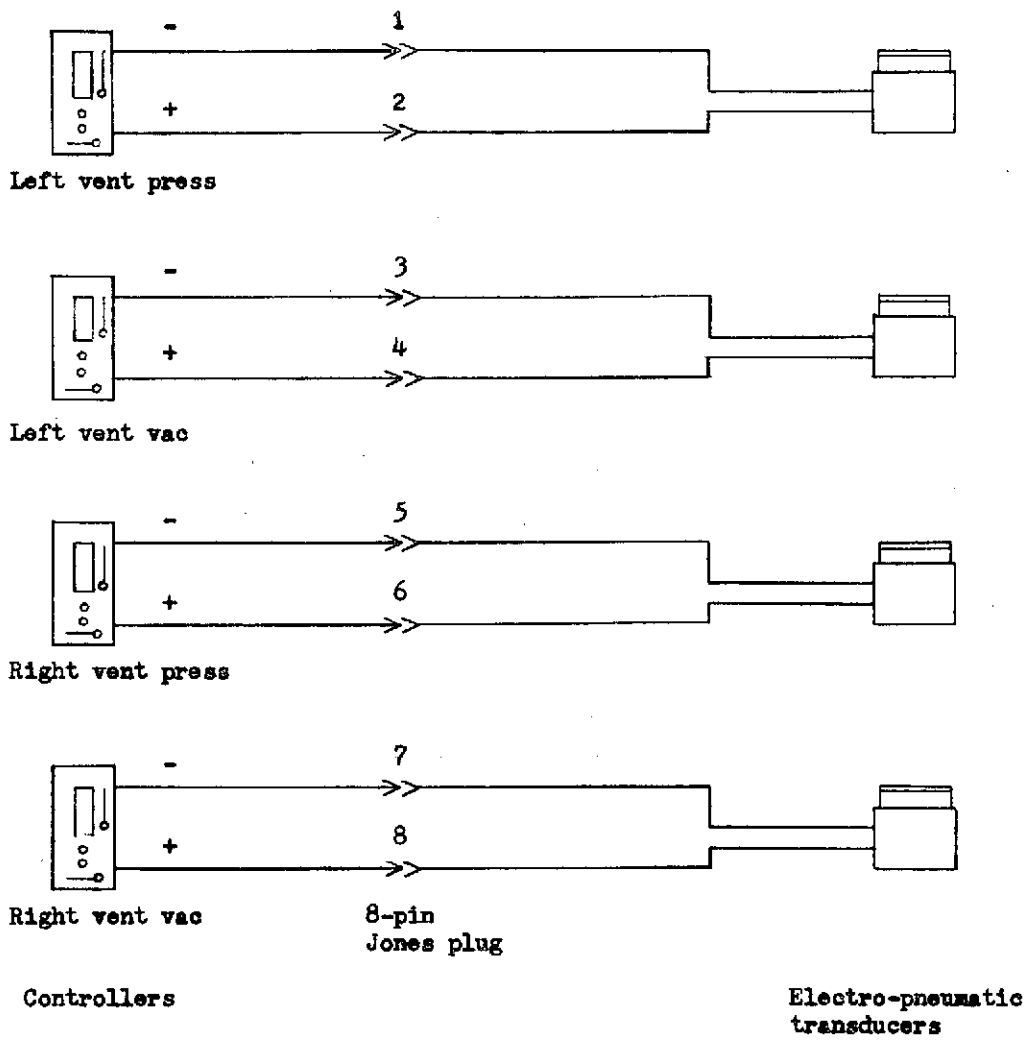

Figure 22. - Schematic of controller output connector.

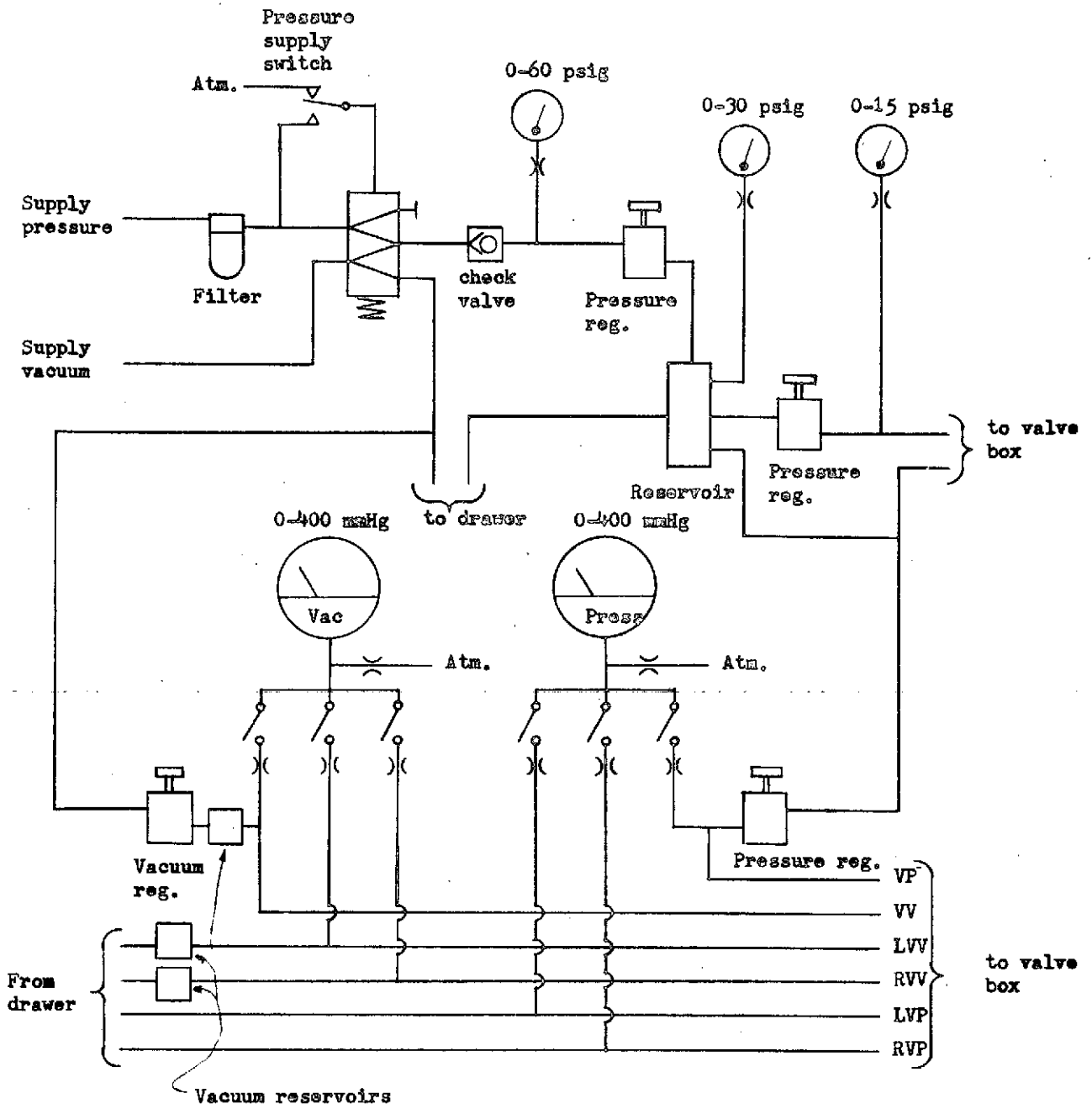

Figure 23. - Pneumatic schematic of supply regulators and monitoring panel.

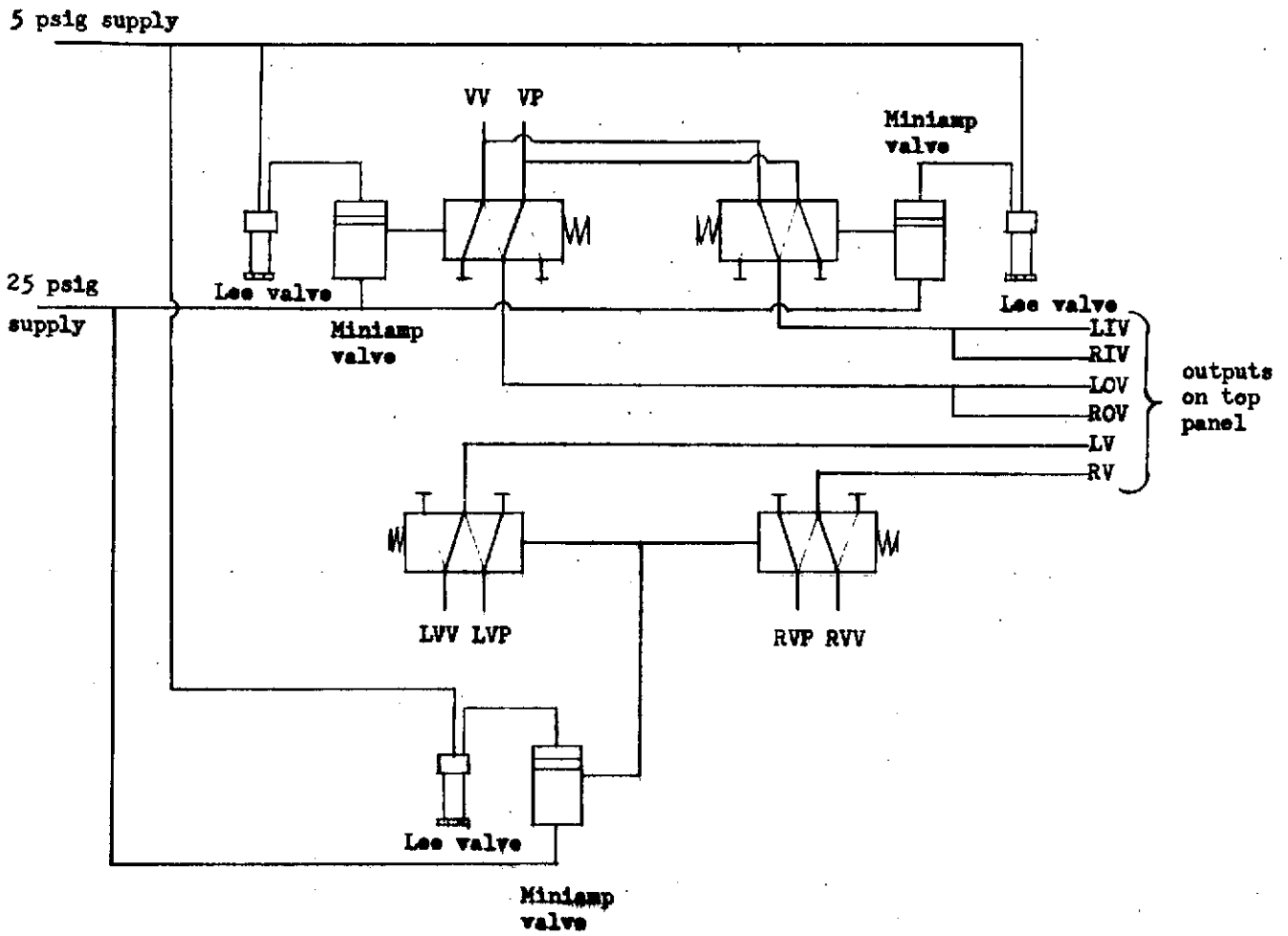

Figure 24. - Pneumatic schematic of switching valve box.

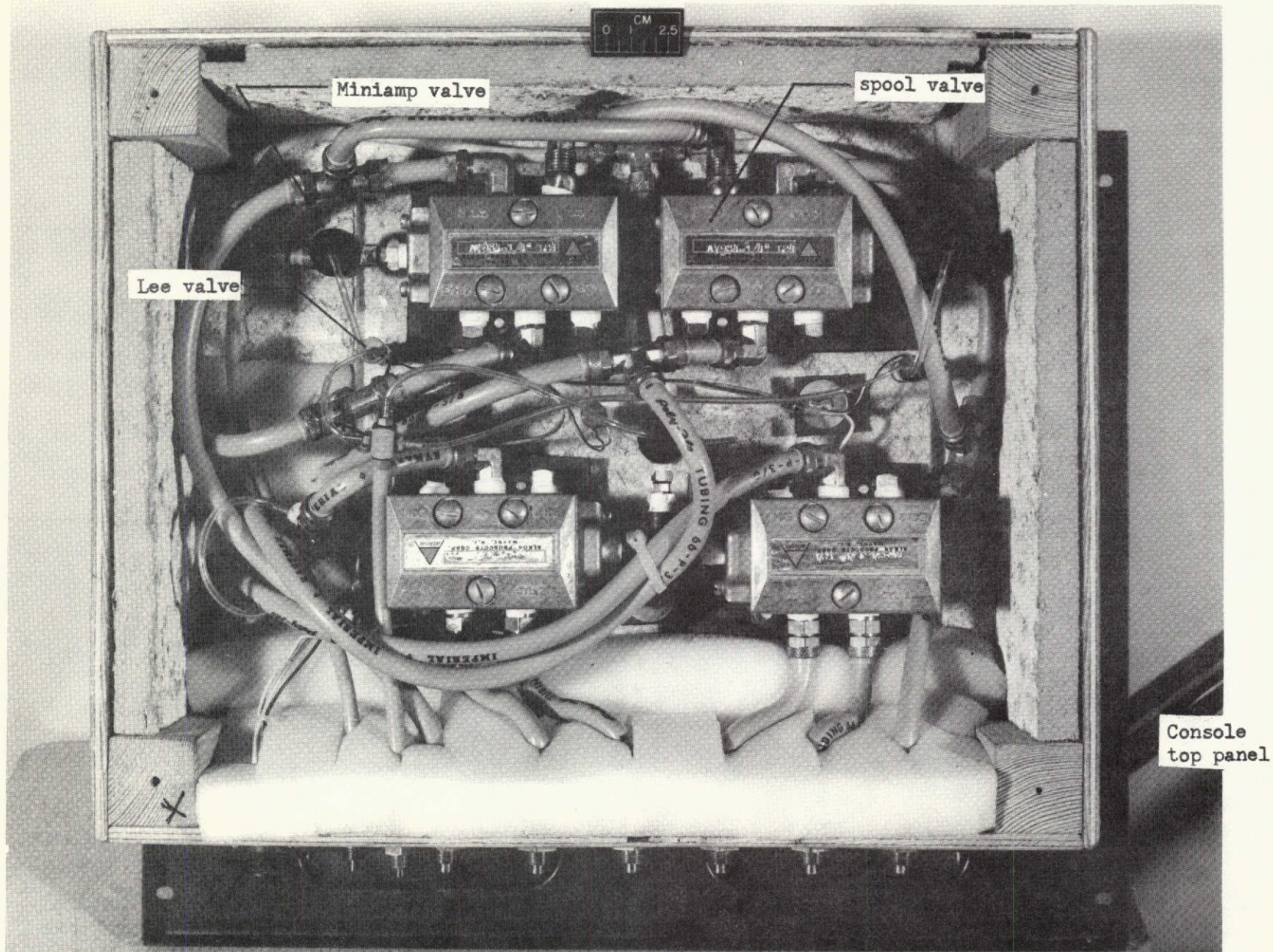

Figure 25. - MVAS spool valve box.