

NATIONAL AERONAUTICS AND SPACE ADMINISTRATION

Technical Memorandum 33-651

Revision 1

*Design Parameters for Toroidal and
Bobbin Magnetics*

Colonel W. T. McLyman

PRICES SUBJECT TO CHANGE

(NASA-CR-139248) DESIGN PARAMETERS FOR
TOROIDAL AND BOBBIN MAGNETICS (Jet
Propulsion Lab.)

N74-29579

CSCL 09E

Unclas

G3/09

54898

Reproduced by
**NATIONAL TECHNICAL
INFORMATION SERVICE**
US Department of Commerce
Springfield, VA. 22151

**JET PROPULSION LABORATORY
CALIFORNIA INSTITUTE OF TECHNOLOGY
PASADENA, CALIFORNIA**

July 1, 1974

NATIONAL AERONAUTICS AND SPACE ADMINISTRATION

Technical Memorandum 33-651

*Design Parameters for Toroidal and
Bobbin Magnetics*

Revision 1

Colonel W. T. McLyman

JET PROPULSION LABORATORY
CALIFORNIA INSTITUTE OF TECHNOLOGY
PASADENA, CALIFORNIA

July 1, 1974

;

Prepared Under Contract No. NAS 7-100
National Aeronautics and Space Administration

PREFACE

The work described in this report was performed by the Guidance and Control Division of the Jet Propulsion Laboratory.

PRECEDING PAGE BLANK NOT FILMED

ACKNOWLEDGMENT

The author wishes to express his thanks to Dr. G. Wester, and Mr. T. Koerner, of JPL, and Mr. R. Noah of Magnetic Inc. for support in gathering data and for their technical aid.

CONTENTS

I.	Introduction	1
II.	Conversion Data for Wire Sizes from #10 to #44	4
III.	Temperature Correction Factors	6
IV.	Toroidal Fill Factors	7
V.	Core Size Selection	12
VI.	Toroid Powder Core Selection with dc Current	18
VII.	Calculation of Outside Diameter of Wound Toroid	23
VIII.	Magnetic and Dimensional Specifications for Thirteen Commonly Used Molypermalloy Cores	25
IX.	Core Loss for Molypermalloy Powder Cores	52
X.	Powder Core (Permeability versus dc Bias)	54
XI.	Lamination, C Core and Bobbin Magnetic and Dimensional Specifications	56
	A. Definitions for Tables 16 through 41	56
	B. Nomographs for 11 Laminations and 15 C Core Sizes	57
XII.	Temperature Rise versus Surface Area Dissipation due to Power Loss, Figure 51	110
XIII.	Maximum Permissible Current Density for 50° C Rise, Figures 52, 53 and 54	112
XIV.	Permeability and Air Gap	118
XV.	Engineering Aids	122
	References	127

TABLES

1.	Conversion Factors	2
2.	Wire Table	5
3.	Magnetic Inc 55051-A2, Arnold Engineering A-051027-2	26
4.	Magnetic Inc 55121-A2, Arnold Engineering A-266036-2	28

CONTENTS (contd)

TABLES (contd)

5.	Magnetic Inc 55848-A2, Arnold Engineering A-848032-2	30
6.	Magnetic Inc 55059-A2, Arnold Engineering A-059043-2	32
7.	Magnetic Inc 55894-A2, Arnold Engineering A-894075-2	34
8.	Magnetic Inc 55071-A2, Arnold Engineering A-291061-2	36
9.	Magnetic Inc 55586-A2, Arnold Engineering A-34503802	38
10.	Magnetic Inc 55076-A2, Arnold Engineering A-076056-2	40
11.	Magnetic Inc 55083-A2, Arnold Engineering A-083081-2	42
12.	Magnetic Inc 55439-A2, Arnold Engineering A-759135-2	44
13.	Magnetic Inc 55090-A2, Arnold Engineering A-090086-2	46
14.	Magnetic Inc 55716-A2, Arnold Engineering A-106073-2	48
15.	Magnetic Inc 55110-A2, Arnold Engineering A-488075-2	50
16.	Lamination EE-30-31	58
17.	Lamination EE-28-29	60
18.	Lamination EI-187	62
19.	Lamination EE-24-25	64
20.	Lamination EE-26-27	66
21.	Lamination EI-375	68
22.	Lamination EI-50	70
23.	Lamination EI-21	72

CONTENTS (contd)

TABLES (contd)

24.	Lamination EI-625	74
25.	Lamination EI-75	76
26.	Lamination EI-87	78
27.	"C" Core Magnetic Inc MC 0001	80
28.	"C" Core Magnetic Inc MC 0002	82
29.	"C" Core Magnetic Inc MC 0004	84
30.	"C" Core Magnetic Inc MC 8400	86
31.	"C" Core Magnetic Inc MC 1200	88
32.	"C" Core Magnetic Inc MC 4400	90
33.	"C" Core Magnetic Inc MC 2300	92
34.	"C" Core Magnetic Inc MC 1300	94
35.	"C" Core Magnetic Inc MC 0014	96
36.	"C" Core Magnetic Inc MC 1030	98
37.	"C" Core Magnetic Inc MC 1000	100
38.	"C" Core Magnetic Inc MC 1610	102
39.	"C" Core Magnetic Inc MC 2000	104
40.	"C" Core Magnetic Inc MC 6800	106
41.	"C" Core Magnetic Inc MC 1620	108
42.	A. I. E. E. - Preferred Tape Wound Toroidal Cores	126

FIGURES

1.	Resistance Correction Factor (ζ , Zeta) for wire temperature between -50° and 100°C	6
2.	Fill Factor 0.5	9
3.	Fill Factor 0.6	10
4.	Fill Factor 0.7	11

CONTENTS (contd)

FIGURES (contd)

5.	Wa Ac versus Output Power	16
6.	Transformer Weight versus Power Output	17
7.	Wa Ac versus $LI^2/2$	21
8.	Inductor Weight versus $LI^2/2$	22
9.	Calculation of Outside Diameter of Wound Toroid	23
10.	Nomograph for Core 55051-A2	27
11.	Nomograph for Core 55121-A2	29
12.	Nomograph for Core 55848-A2	31
13.	Nomograph for Core 55059-A2	33
14.	Nomographs for Core 55894-A2	35
15.	Nomograph for Core 55071-A2	37
16.	Nomograph for Core 55586-A2	39
17.	Nomograph for Core 55076-A2	41
18.	Nomograph for Core 55083-A2	43
19.	Nomograph for Core 55439-A2	45
20.	Nomograph for Core 55090-A2	47
21.	Nomograph for Core 55716-A2	49
22.	Nomograph for Core 55110-A2	51
23.	Core Loss versus Frequency at 0.05T, 0.1T, and 0.5T. . .	53
24.	Permeability vs dc Bias	55
25.	Nomograph for Lamination EE-30-31	59
26.	Nomograph for Lamination EE-28-29	61
27.	Nomograph for Lamination E1-187	63
28.	Nomograph for Lamination EE-24-25	65

CONTENTS (contd)

FIGURES (contd)

29.	Nomograph for Lamination EE-26-27	67
30.	Nomograph for Lamination EI-375	69
31.	Nomograph for Lamination EI-50	71
32.	Nomograph for Lamination EI-21	73
33.	Nomograph for Lamination EI-625	75
34.	Nomograph for Lamination EI-75	77
35.	Nomograph for Lamination EI-87	79
36.	Nomograph for "C" Core MC 0001	81
37.	Nomograph for "C" Core MC 0002	83
38.	Nomograph for "C" Core MC 0004	85
39.	Nomograph for "C" Core MC 8400	87
40.	Nomograph for "C" Core MC 1200	89
41.	Nomograph for "C" Core MC 4400	91
42.	Nomograph for "C" Core MC 2300	93
43.	Nomograph for "C" Core MC 1300	95
44.	Nomograph for "C" Core MC 0014	97
45.	Nomograph for "C" Core MC 1030	99
46.	Nomograph for "C" Core MC 1000	101
47.	Nomograph for "C" Core MC 1610	103
48.	Nomograph for "C" Core MC 2000	105
49.	Nomograph for "C" Core MC 6800	107
50.	Nomograph for "C" Core MC 1620	109
51.	Temperature Rise versus Surface Dissipation	111
52.	Current Density vs Surface Area for a 50° C Rise (Lamination)	113

CONTENTS (contd)

FIGURES (contd)

53.	Current Density vs Surface Area for a 50°C Rise (Toroid)	114
54.	Current Density vs Surface Area for a 50°C Rise (C Cores)	115
55.	Lamination A_t	116
56.	Toroid A_t	116
57.	C Core A_t	117
58.	Hysteresis Loop	118
59.	Stack 1 x 1	119
60.	Stack 5 x 5	120
61.	Stack 15 x 15	120
62.	Stack 32 x 32	120
63.	Butt Stack	121
64.	Butt Stack 25 μm Gap	121
65.	Butt Stack 50 μm Gap	121
66.	Stack 1/2 1 x 1 and 1/2 Butt Stack	122
67.	Nomograph for Inductance, Capacitance, and Reactance	123
68.	Computation of Mean Turn Length	124
69.	Silicone, Cobalt, and Nickel Iron Core Loss Curves	125

LIST OF SYMBOLS

AWG	American wire gage
cir-mil	area of a circle whose diameter = 0.001 inches
ζ	zeta resistance correction factor for temperature
K_1	conductor area cm^2 /wire area cm^2
K_2	wound area cm^2 /usable window area cm^2
K_3	usable window area cm^2 /window area cm^2
K	window utilization factor
A_w	wire area
A_c	iron area gross
lm	magnetic path
MLT	mean length turn
A_t	surface area of a transformer
μ	permeability
W_c	copper loss
W_I	iron loss
W_T	total loss
T	tesla 1 tesla = 1×10^{-4} gauss
R	resistance
I	current (RMS)
E	voltage (RMS)
B_m	operating flux density teslas
f	frequency Hz
W_a	window area
J	current density
P_o	output power
P_i	input power
P_T	total power
η	efficiency
L	inductance
ϕ	flux webers
μ_r	relative permeability
μ_o	absolute permeability ($4\pi \times 10^{-7}$)
H	magnitizing force ampturns/cm 1 amp turn/cm = 0.79 oersted
m	meter

ABSTRACT

The adoption by NASA of the metric system for dimensioning to replace the long-used English units imposes a requirement on the U.S. transformer designer to convert from the familiar units to the less familiar metric equivalents. Material is presented to assist in that transition in the field of transformer design and fabrication. The conversion data makes it possible for the designer to obtain a fast and close approximation of significant parameters such as size, weight, and temperature rise. Nomographs are included to provide a close approximation for breadboarding purposes. For greater convenience, derivations of some of the parameters are also presented.

I. INTRODUCTION

The adoption by NASA of the metric system for dimensioning to replace the long-used English units imposes a requirement on the U. S. transformer designer to convert from the familiar units to the less familiar metric equivalents, Table 1. The following material is intended to assist in that transition in the field of transformer design and fabrication. The conversion data makes it possible for the designer to obtain a fast and close approximation of significant parameters such as size, weight, and temperature rise. For greater convenience, derivations of some of the parameters are also presented.

Table 1. Conversion Factors

Area	
To convert	Multiply By
Circular Mils to Square Inches	7.854×10^{-7}
Circular Mils to Square Mils	7.854×10^{-1}
Circular Mils to Square Millimeters	5.066×10^{-4}
Square Centimeters to Square Inches	1.55×10^{-1}
Square Feet to Square Meters	9.29×10^{-2}
Square Inches to Circular Mils	1.273×10^6
Square Inches to Square Centimeters	6.4516
Square Inches to Square Millimeters	6.4516×10^2
Square Inches to Square Mils	1.000×10^6
Square Meters to Square Feet	1.0764×10^1
Square Millimeters to Square Inches	1.55×10^{-3}
Square Millimeters to Circular Mils	1.973×10^3
Square Mils to Circular Mils	1.2732
Square Mils to Square Inches	1.00×10^{-6}
Length	
Centimeters to Inches	3.937×10^{-1}
Centimeters to Feet	3.281×10^{-2}
Feet to Centimeters	3.048×10^1
Feet to Meters	3.048×10^{-1}
Inches to Centimeters	2.54
Inches to Meters	2.54×10^{-2}
Inches to Millimeters	2.54×10^1
Inches to Mils	1.00×10^3
Kilometers to Miles	6.214×10^{-1}
Meters to Feet	3.2808
Meters to Inches	3.937×10^1
Meters to Yards	1.0936
Miles to Kilometers	1.6039

Table 1. (contd)

Length (contd)	
To convert	Multiply By
Millimeters to Inches	3.937×10^{-2}
Millimeters to Mils	3.937×10^1
Mils to Inches	1.00×10^{-3}
Mils to Millimeters	2.54×10^{-2}
Yards to Meters	9.144×10^{-1}
Weight (wt)	
Ounces to Pounds	6.25×10^{-2}
Ounces to Grams	2.8349×10^1
Pounds to Ounces	1.6×10^1
Pounds to Grams	4.5359×10^2
Grams to Ounces	3.527×10^{-2}
Grams to Pounds	2.205×10^{-3}

II. CONVERSION DATA FOR WIRE SIZES FROM #10 to #44

Columns A and B in Table 2 give the bare area in the commonly used circular mils notation and in the metric equivalent for each wire size. Column C gives the equivalent resistance in microhms/centimeter ($\mu\Omega/\text{cm}$ or $10^{-6}\Omega/\text{cm}$). Columns D to L relate to coated wires showing the effect of insulation on size and the number of turns and the total weight in grams/centimeter.

The total resistance for a given winding may be calculated by multiplying the MLT (mean length/turn) of the winding in centimeters, by the microhms/cm for the appropriate wire size, and the total number of turns. Thus

$$R = (\text{MLT}) \cdot \left(\frac{\mu\Omega}{\text{cm}}\right) \cdot (N)$$

The weight of the copper in a given winding may be calculated by multiplying the MLT by the grams/cm (column M) and by the total number of turns. Thus

$$\text{wt} = (\text{MLT}) \cdot \left(\frac{\text{gm}}{\text{cm}}\right) \cdot (N)$$

Turns per square inch and turns per square cm are based on 60% wire fill factor.

Table 2. Wire Table

Awg Wire Size	Bare Area		Resistance $\frac{10^{-6} \Omega}{\text{cm at } 20^\circ\text{C}}$	Heavy Synthetics								
	$\text{cm}^2 \cdot 10^{-3}$ (footnote b)	CIR-MIL ^a		Area		Diameter		Turns-Per		Turns-Per		Weight gm/cm
			$\text{cm}^2 \cdot 10^{-3}$	CIR-MIL ^a	cm	Inch ^a	cm	Inch ^a	cm ²	Inch ²		
10	52.61	10384	32.70	55.9	11046	0.267	0.1051	3.87	9.5	10.73	69.20	0.468
11	41.68	8226	41.37	44.5	8798	0.238	0.0938	4.36	10.7	13.48	89.95	0.3750
12	33.08	6529	52.09	35.64	7022	0.213	0.0838	4.85	11.9	16.81	108.4	0.2977
13	26.26	5184	65.64	28.36	5610	0.190	0.0749	5.47	13.4	21.15	136.4	0.2367
14	20.82	4109	82.80	22.95	4556	0.171	0.0675	6.04	14.8	26.14	168.6	0.1879
15	16.51	3260	104.3	18.37	3624	0.153	0.0602	6.77	16.6	32.66	210.6	0.1492
16	13.07	2581	131.8	14.73	2905	0.137	0.0539	7.32	18.6	40.73	262.7	0.1184
17	10.39	2052	165.8	11.68	2323	0.122	0.0482	8.18	20.8	51.36	331.2	0.0943
18	8.228	1624	209.5	9.326	1857	0.109	0.0431	9.13	23.2	64.33	414.9	0.07472
19	6.531	1289	263.9	7.539	1490	0.0980	0.0386	10.19	25.9	79.85	515.0	0.05940
20	5.188	1024	332.3	6.065	1197	0.0879	0.0346	11.37	28.9	98.93	638.1	0.04726
21	4.116	812.3	418.9	4.837	954.8	0.0785	0.0309	12.75	32.4	124.0	799.8	0.03757
22	3.243	640.1	531.4	3.857	761.7	0.0701	0.0276	14.25	36.2	155.5	1003	0.02965
23	2.588	510.8	666.0	3.135	620.0	0.0632	0.0249	15.82	40.2	191.3	1234	0.02372
24	2.047	404.0	842.1	2.514	497.3	0.0566	0.0223	17.63	44.8	238.6	1539	0.01884
25	1.623	320.4	1062.0	2.002	396.0	0.0505	0.0199	19.80	50.3	299.7	1933	0.01498
26	1.280	252.8	1345.0	1.603	316.8	0.0452	0.0178	22.12	56.2	374.2	2414	0.01185
27	1.021	201.6	1687.6	1.313	259.2	0.0409	0.0161	24.44	62.1	456.9	2947	0.00945
28	0.8046	158.8	2142.7	1.0515	207.3	0.0366	0.0144	27.32	69.4	570.6	3680	0.00747
29	0.6470	127.7	2664.3	0.8548	169.0	0.0330	0.0130	30.27	76.9	701.9	4527	0.00602
30	0.5067	100.0	3402.2	0.6785	134.5	0.0294	0.0116	33.93	86.2	884.3	5703	0.00472
31	0.4013	79.21	4294.6	0.5596	110.2	0.0267	0.0105	37.48	95.2	1072	6914	0.00372
32	0.3242	64.00	5314.9	0.4559	90.25	0.0241	0.0095	41.45	105.3	1316	8488	0.00305
33	0.2554	50.41	6748.6	0.3662	72.25	0.0216	0.0085	46.33	117.7	1638	10565	0.00241
34	0.2011	39.69	8572.8	0.2863	56.25	0.0191	0.0075	52.48	133.3	2095	13512	0.00189
35	0.1589	31.36	10849	0.2268	44.89	0.0170	0.0067	58.77	149.3	2645	17060	0.00150
36	0.1266	25.00	13608	0.1813	36.00	0.0152	0.0060	65.62	166.7	3309	21343	0.00119
37	0.1026	20.25	16801	0.1538	30.25	0.0140	0.0055	71.57	181.8	3901	25161	0.000977
38	0.08107	16.00	21266	0.1207	24.01	0.0124	0.0049	80.35	204.1	4971	32062	0.000773
39	0.06207	12.25	27775	0.0932	18.49	0.0109	0.0043	91.57	232.6	6437	41518	0.000593
40	0.04869	9.61	35400	0.0723	14.44	0.0096	0.0038	103.6	263.2	8298	53522	0.000464
41	0.03972	7.84	43405	0.0584	11.56	0.00863	0.0034	115.7	294.1	10273	66260	0.000379
42	0.03166	6.25	54429	0.04558	9.00	0.00762	0.0030	131.2	333.3	13163	84901	0.000299
43	0.02452	4.84	70308	0.03683	7.29	0.00685	0.0027	145.8	370.4	16291	105076	0.000233
44	0.0202	4.00	85072	0.03165	6.25	0.00635	0.0025	157.4	400.0	18957	122272	0.000195

^aThis data from REA Magnetic Wire Datalator (Ref. 1).

^bThis notation means the entry in the column must be multiplied by 10⁻³.

III. TEMPERATURE CORRECTION FACTORS

The values shown in Fig. 1 are based upon a correction factor of 1.0 at 20°C. For other temperatures the effect upon wire resistance can be calculated by multiplying the resistance value for the wire size shown in column C of Table 2 by the appropriate correction factor shown on the graph. Thus,
Corrected Resistance = $\mu\Omega/\text{cm}$ (at 20°C) $\times \zeta$

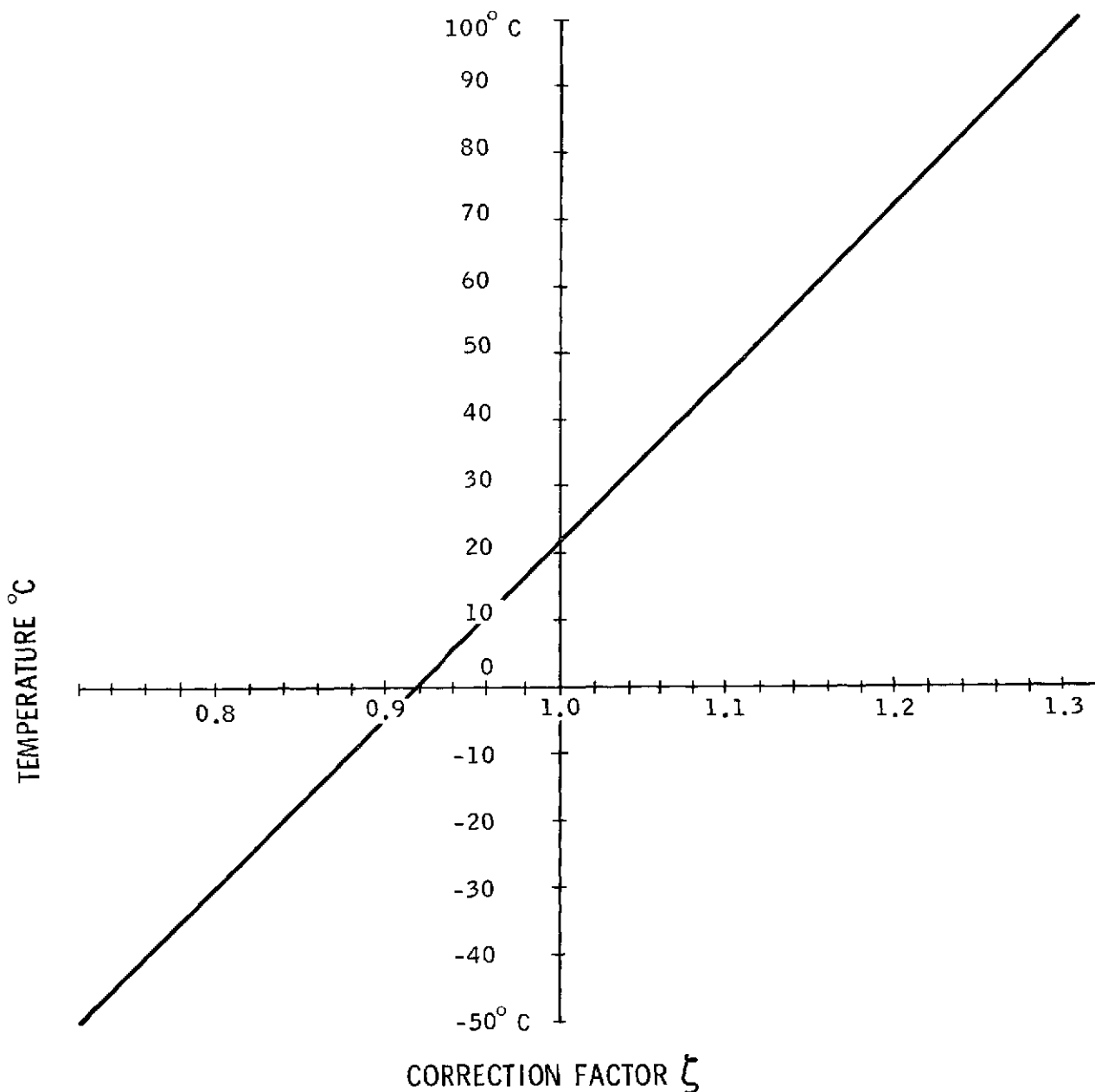

Fig. 1. Resistance Correction Factor (ζ , Zeta) for wire temperature between -50° and 100°C

IV. TOROIDAL FILL FACTORS

Figures 2, 3 and 4 have been devised to assist the engineer in optimizing the dimension of the window in the toroidal core. Available window area for winding turns is affected by:

- (1) Minimum window diameter which may be safely wound
- (2) Total space occupied by wire (copper and insulation)

The fraction of the available window space which will be occupied by the copper may be calculated from

$$K = \frac{\text{conductor cm}^2}{\text{wire cm}^2} \times \frac{\text{wound cm}^2}{\text{usable window cm}^2} \times \frac{\text{usable window cm}^2}{\text{window cm}^2}$$

where

$$\text{conductor cm}^2 = \text{copper cm}^2$$

$$\text{wire cm}^2 = \text{copper cm}^2 + \text{insulation cm}^2$$

$$\text{wound cm}^2 = \text{number of turns} \times \text{wire area of one turn}$$

$$\text{usable window cm}^2 = \text{available window area minus residual area which results from the particular winding technique used}$$

$$\text{window area} = \text{available window cm}^2$$

The term $\frac{\text{conductor cm}^2}{\text{wire cm}^2}$ ($=K_1$) is dependent upon wire size. Typical values which may be calculated from the data of Table 2, Columns A and D are

$$\text{AWG 10} = \frac{52.61 \text{ cm}}{55.90 \text{ cm}} = 0.941$$

$$\text{AWG 20} = \frac{5.188 \text{ cm}}{6.065 \text{ cm}} = 0.855$$

$$\text{AWG 30} = \frac{0.5067 \text{ cm}}{0.6785 \text{ cm}} = 0.747$$

$$\text{AWG 40} = \frac{0.04869 \text{ cm}}{0.0723 \text{ cm}} = 0.673$$

The term $\frac{\text{wound cm}^2}{\text{usable window cm}^2}$ ($=K_2$) is the fill factor for the usable window area. It can be shown theoretically that for circular cross-section wire wound

on a flat form that the ratio of wire cm^2 to the area required for the turns can never be greater than 0.91. In practice, the actual maximum value is dependent upon the tightness of winding, variations in insulation thickness, and wire lay. Consequently, the fill factor is always less than the theoretical maximum.

Design Manual TWC-300 of MAGNETICS, Inc. indicates that random wound cores can be produced with fill factors as high as 0.7, but that progressive sector wound cores can be produced with fill factors of only up to 0.55. The charts of Figures 2, 3 and 4 are based upon fill factor ratios of 0.50, 0.60 and 0.70, respectively. As a typical working value for copper wire with a heavy synthetic film insulation, a ratio of 0.60 may be used safely.

The term usable window cm^2 / window cm^2 (K_3) defines how much of the available window space may actually be used for the winding. The charts are based on the assumption that the inside diameter (ID) of the wound core is one-half that of the bare core, i. e. $K_3 = 0.75$ (to allow free passage of the shuttle).

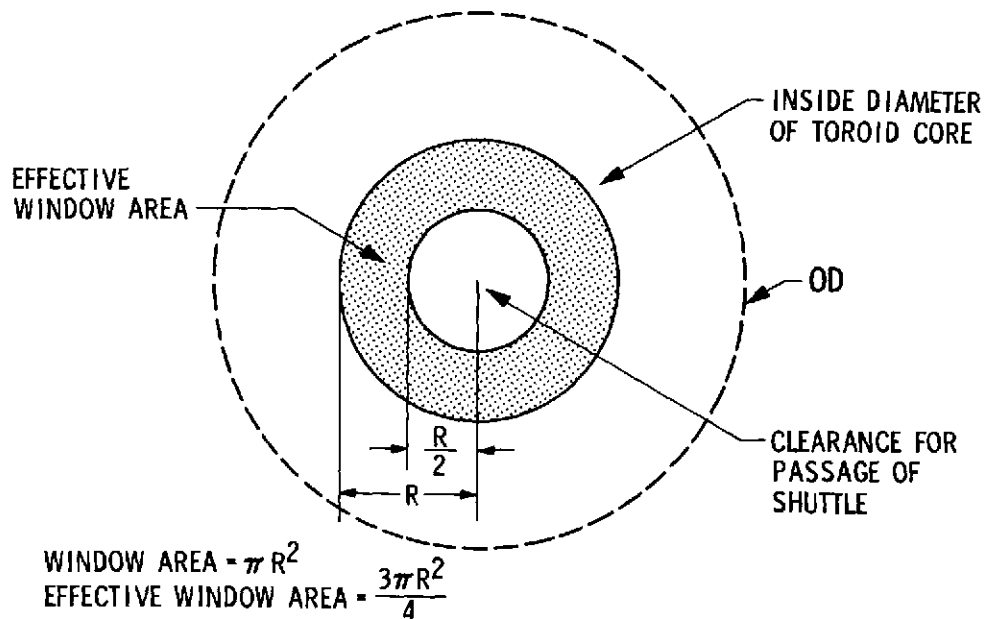

A typical value for the copper fraction in the window area is about 0.40. For example for AWG 20 wire, $K_1 \times K_2 \times K_3 = 0.855 \times 0.60 \times 0.75 = 0.385$.

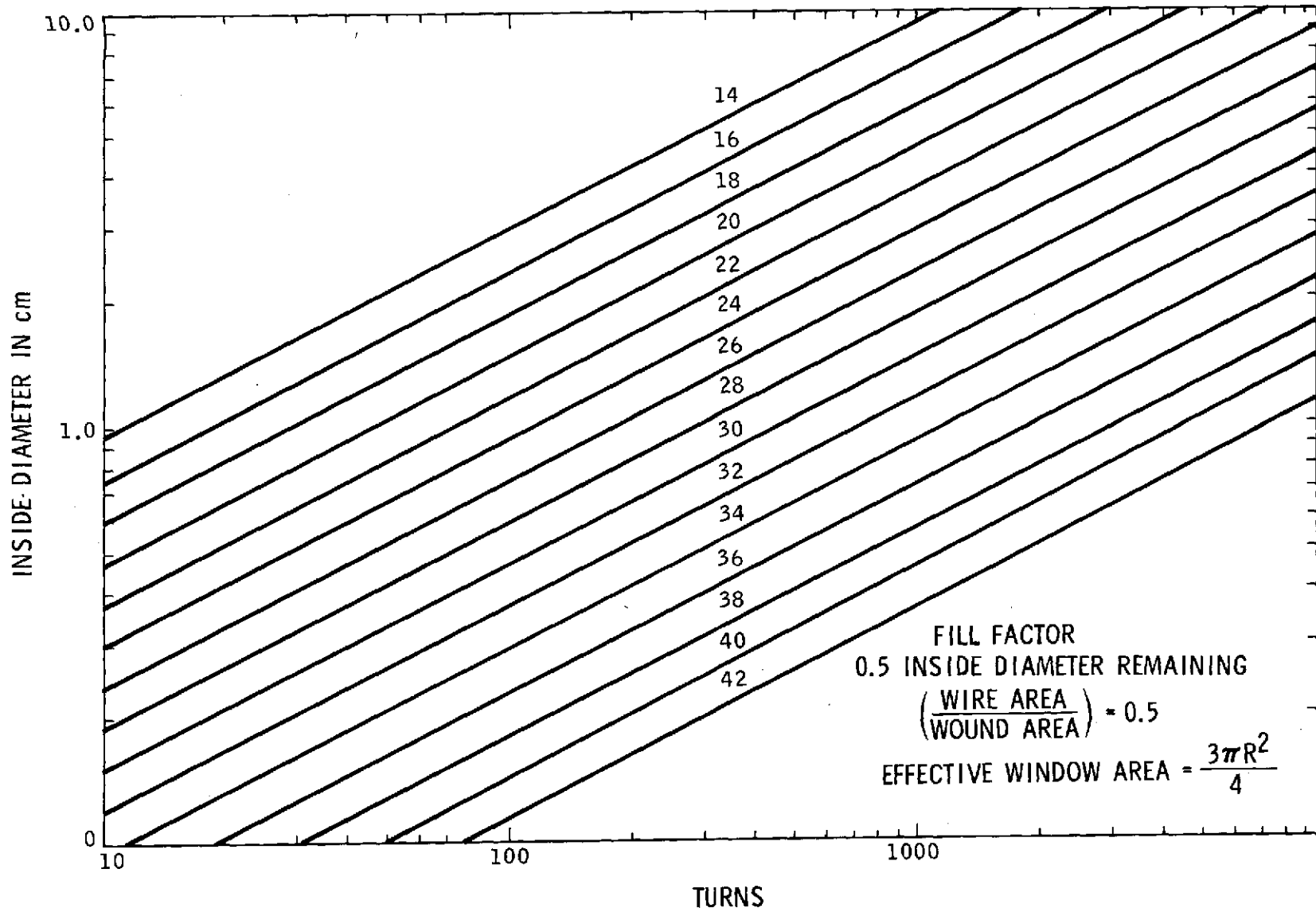

Fig. 2. Fill Factor 0.5

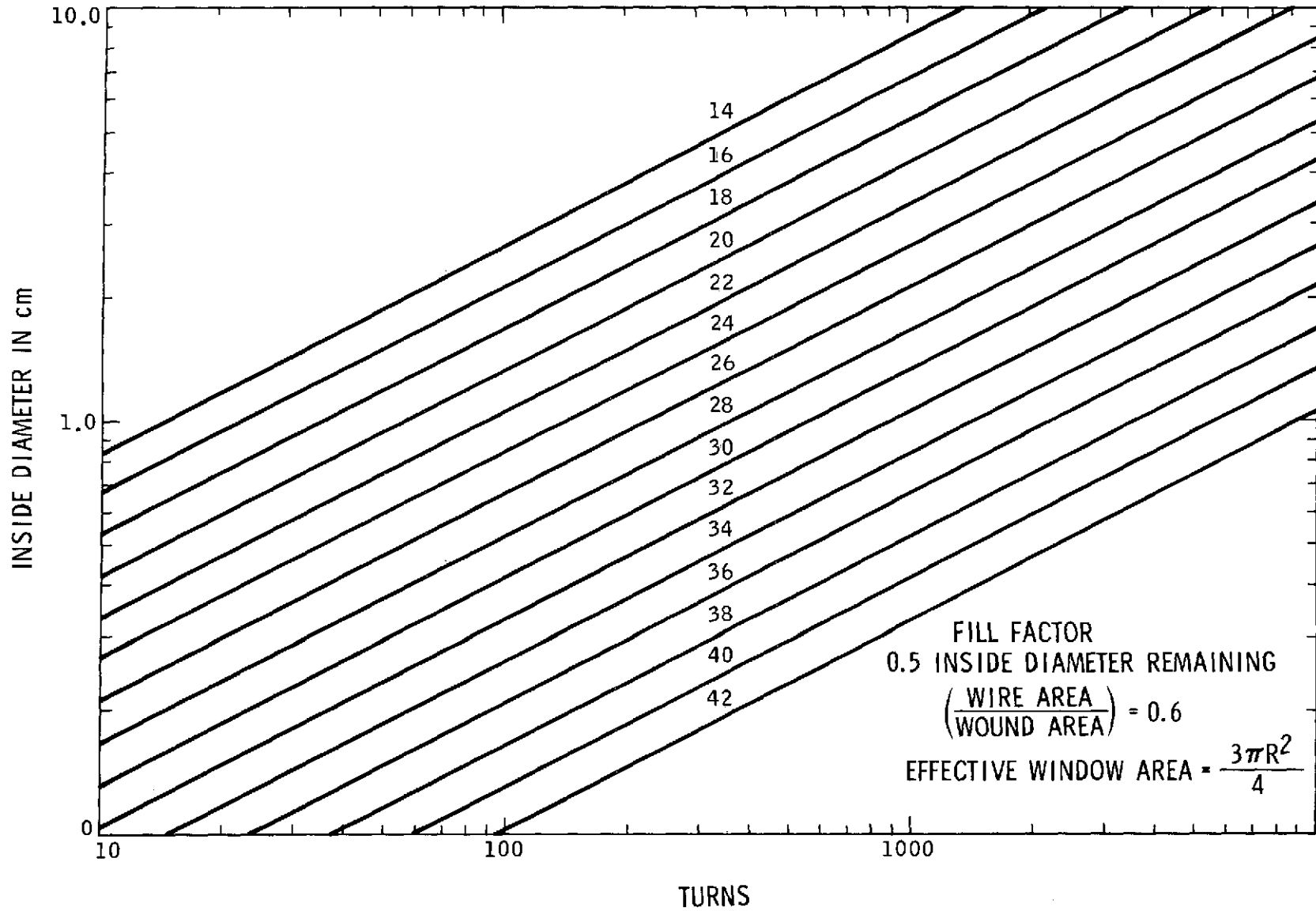

Fig. 3. Fill Factor 0.6

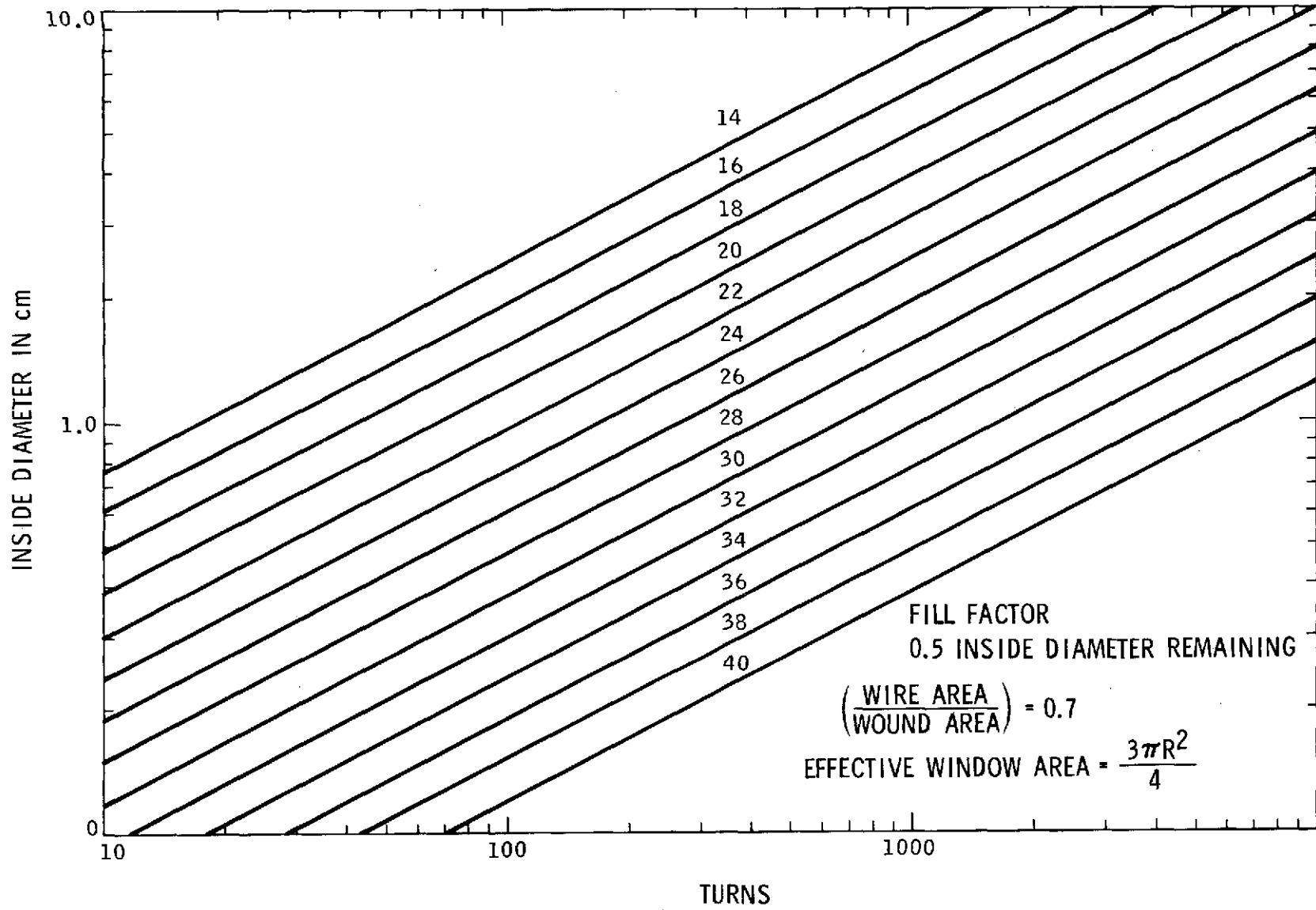

Fig. 4. Fill Factor 0.7

V. CORE SIZE SELECTION

Upon selecting the transformer core material and material thickness, the next step is to select the proper size core for a transformer with a given operating frequency and output power. The power handling capability of a transformer can be determined by its $W_a A_c$ product where W_a is the available core window area in cm^2 and A_c is the core effective cross sectional area in cm^2 .

The $W_a A_c$ relationships are obtained by solving Faraday's Law in the following manner:

$$\text{Faraday's Law} = E = 4B_m A_c N f \times 10^{-4} \text{ (square wave)}$$

$$E = 4.44B_m A_c N f \times 10^{-4} \text{ (sine wave)}$$

$$E = \text{applied voltage (rms)}$$

$$B_m = \text{flux density in teslas}$$

$$A_c = \text{core effective cross sectional area in cm}^2$$

$$N = \text{number of turns}$$

$$f = \text{frequency in Hz}$$

$$A_w = \text{bare wire area in cm}^2$$

$$W_a = \text{window area in cm}^2$$

$$K = \text{window utilization factor}$$

$$I = \text{current (rms)}$$

$$J = \text{current density}$$

$$P_o = \text{output power (total)}$$

$$P_i = \text{input power}$$

$$P_T = \text{total power}$$

$$\eta = \text{efficiency}$$

Solving for

$$NA_c = \frac{E \times 10^4}{4B_m f}$$

Window utilization factor

$$K = \frac{NA_w}{W_a}$$

$$N = \frac{KW_a}{A_w}$$

Multiply both sides by A_c

$$NA_c = \frac{KW_a A_c}{A_w} = \frac{E \times 10^4}{4B_m f}$$

Combining and solving for $W_a A_c$

$$\frac{KW_a A_c}{A_w} = \frac{E \times 10^4}{4B_m f K}$$

$$W_a A_c = \frac{E A_w \times 10^4}{4B_m f K}$$

$$J = \frac{I}{A_w} = \frac{\text{Amp}}{\text{cm}^2}$$

$$\eta = \frac{P_o}{P_I}$$

$$P_I = EI$$

$$E A_w = \frac{EI}{J} = \frac{P_I}{J} = \frac{P_o}{J\eta}$$

$$Wa Ac \left| \begin{array}{l} \\ \text{total} \end{array} \right. = Wa Ac \left| \begin{array}{l} \\ \text{primary} \end{array} \right. + Wa Ac \left| \begin{array}{l} \\ \text{secondary} \end{array} \right.$$

$$Wa Ac \left| \begin{array}{l} \\ \text{total} \end{array} \right. = \frac{P_o}{J} \times \frac{10^4}{4B_m f K} + \frac{P_o 10^4}{4B_m f K J} = \frac{P_o 10^4}{4B_m f K J} (1/\eta + 1)$$

$$P_T = \frac{P_o}{\eta} + P_o$$

$$Wa Ac = \frac{P_T \times 10^4}{4B_m f K J}$$

Window utilization factor K

$$\left. \begin{array}{l} \text{Lamination and Bobbin} \\ \text{Toroid 1/2 ID remaining} \\ \text{C Core and Bobbin} \end{array} \right\} \frac{Wa (eff)}{Wa} \times \text{Fill Factor} \times \frac{Aw Bare}{Aw Total} = 0.4$$

$$Wa Ac = \frac{P_T \times 10^4}{1.6 \times B_m f J} \text{ square wave}$$

$$Wa Ac = \frac{P_T \times 10^4}{1.77 \times B_m f J} \text{ sine wave}$$

The curve in Fig. 5 shows the required core $Wa Ac$ product plotted against transformer output power for different frequency. The values held constant were:

$$B_m = 0.3T$$

$$J = 200 \text{ Amps/cm}^2$$

$$K = 0.40$$

$$\eta = 95\%$$

These values were held constant so that one nomograph could be used with all materials and the Engineer could adjust B_m , J , K and η to fit the design. From the equation

$$Wa Ac = \frac{P_T \times 10^4}{1.6 \times B_m f J}$$

two nomographs were generated to compare output power

$$P_o = \frac{P_T}{(1/\eta + 1)}$$

with $Wa Ac$ and P_o with weight. These nomographs were generated from the lamination and C core in the article. The nomograph in Fig. 5 compares P_o with $Wa Ac$, thus the size of the transformer can quickly be determined. The nomograph in Fig. 6 compares power with weight, thus the weight of a fully wound transformer can quickly be determined. These nomographs have the following constraints:

$$B_m = 0.3T$$

$$J = 200 \text{ A/cm}^2$$

$$K = 0.4$$

More than likely after the $Wa Ac$ has been selected a slight reshuffle of the constraints is required to correspond to the actual core $Wa Ac$ product.

TRANSFORMER

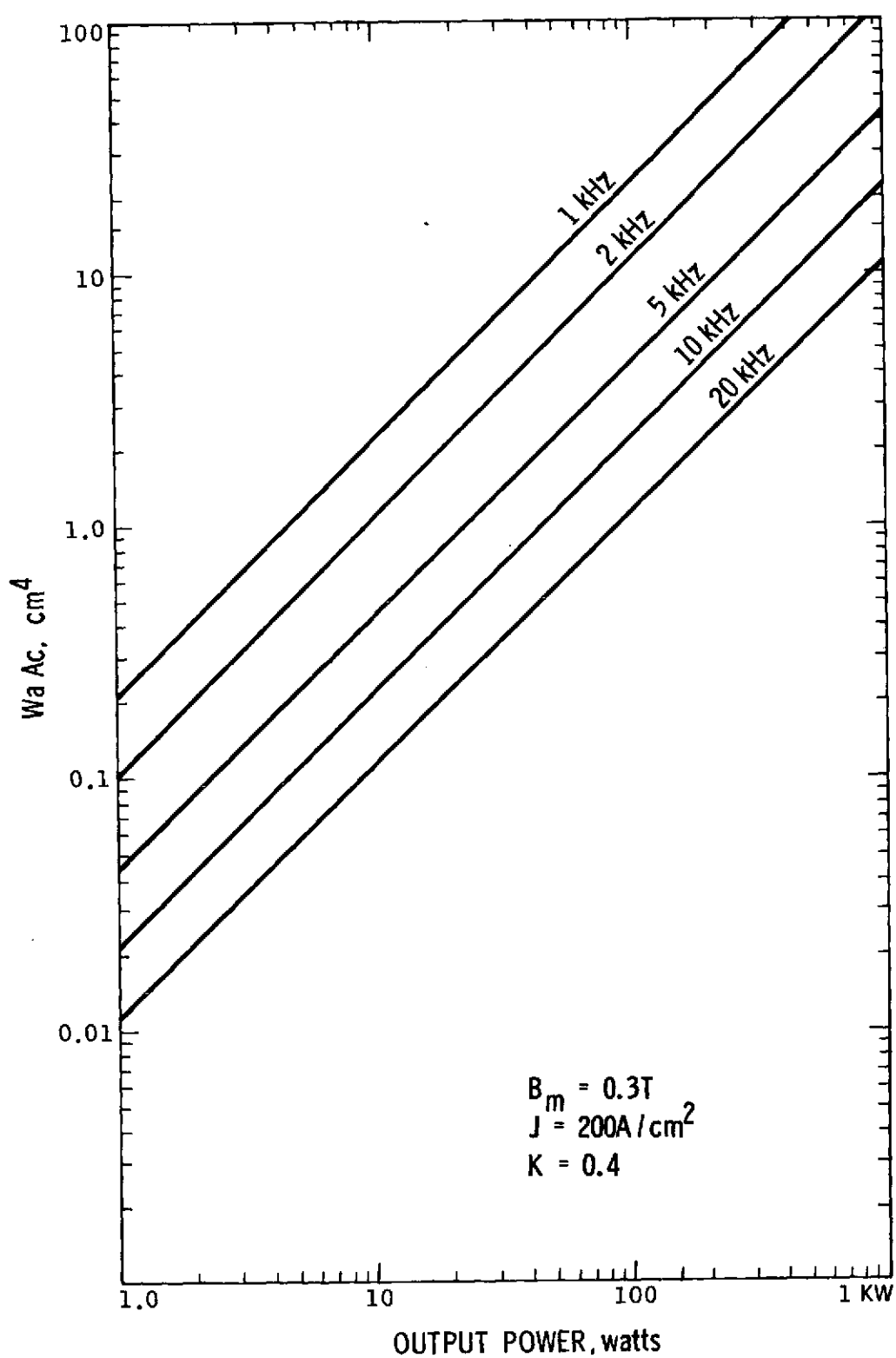

Fig. 5. $W_a A_c$ versus Output Power

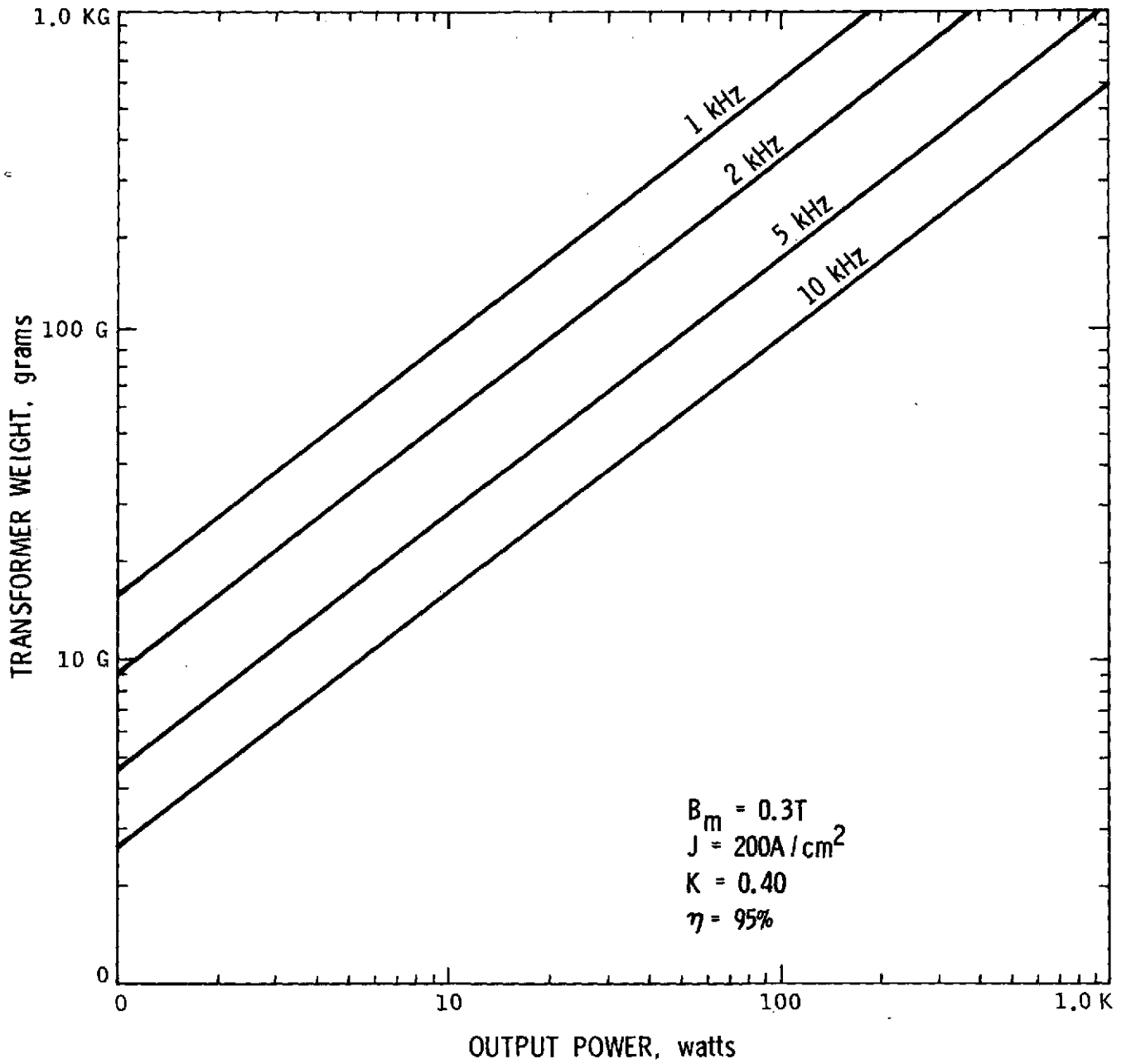

Fig. 6. Transformer Weight versus Power Output

VI. TOROID POWDER CORE SELECTION WITH dc CURRENT

After calculating the inductance and dc current, select the proper permeability and size powder core with a given $LI^2/2$. The energy handling capability of an inductor can be determined by its $Wa Ac$ product where Wa is the available core window area in cm^2 and Ac is the core effective cross sectional area cm^2 . The $Wa Ac$ relationship are obtained by solving $E = L dI/dT$ as follows:

$$E = L \frac{dI}{dt} = N \frac{d\phi}{dt}$$

$$L = N \frac{d\phi}{dI}$$

$$\phi = B_m Ac'$$

$$B_m = \mu_r \mu_o H' = \frac{\mu_r \mu_o NI}{lm'}$$

$$\phi = \frac{\mu_r \mu_o NI Ac'}{lm'}$$

$$\frac{d\phi}{dI} = \frac{\mu_r \mu_o N Ac'}{lm'}$$

$$L = N \frac{d\phi}{dI} = \frac{\mu_r \mu_o N^2 Ac'}{lm'}$$

$$\text{Energy} = \frac{1}{2} LI^2 = \frac{\mu_r \mu_o N^2 Ac'}{2lm'} I^2$$

If B_m is specified,

$$I = \frac{B_m lm'}{\mu_r \mu_o N}$$

E = voltage, volts

L = inductance, henrys

I = current, amperes

N = number of turns

ϕ = flux, webers

B_m = flux density, teslas

Ac' = core cross section, m^2

μ_r = relative permeability

μ_o = absolute permeability ($4\pi \times 10^{-7}$)

H' = magnetizing force, amp turns/m

lm' = magnetic path length, m

K = window utilization factor

Wa' = window area, m^2

J' = current density, amps/ m^2

Eng = energy, watt seconds

$$\text{Eng} = \frac{\mu_r \mu_o N^2 \text{Ac}' \left(\frac{B_m \text{lm}'}{\mu_r \mu_o N} \right)^2}{2 \text{lm}'} = \frac{B_m^2 \text{lm}' \text{Ac}'}{2 \mu_r \mu_o} \text{ watt seconds}$$

$$I = \frac{K \text{Wa}' J'}{N} = \frac{B_m \text{lm}'}{\mu_r \mu_o N}$$

Solving for $\mu_r \mu_o$

$$\mu_r \mu_o = \frac{B_m \text{lm}'}{K \text{Wa}' J'}$$

Substituting into the energy equation

$$\text{Eng} = \frac{B_m^2 \text{lm}' \text{Ac}'}{2} \cdot \frac{K \text{Wa}' J'}{B_m \text{lm}'} = \frac{\text{Wa}' \text{Ac}' B_m J' K}{2}$$

let

Wa = window area, cm^2

Ac = core area, cm^2

J = current density, amps/cm^2

Wa' = $\text{Wa} \times 10^{-4}$

Ac' = $\text{Ac} \times 10^{-4}$

J' = $J \times 10^4$

Substituting into the energy equation

$$\text{Eng} = \frac{\text{Wa} \text{Ac} B_m J K}{2} \times 10^{-4}$$

Solving for Wa Ac,

$$\text{Wa} \text{Ac} = \frac{2 (\text{Eng})}{B_m J K} \times 10^4$$

let

l_m = magnetic path length, cm

$$l_m' = l_m \times 10^{-2}$$

$$\mu_r = \frac{B_m l_m \times 10^{-2}}{K \mu_o (W_a \times 10^{-4})(J \times 10^4)} = \frac{B_m l_m \times 10^{-2}}{\mu_o W_a J K}$$

for $\mu_o = 4\pi \times 10^{-7}$

$$\mu_r = \frac{B_m l_m \times 10^{-2}}{4\pi \times 10^{-7} W_a J K} = \frac{B_m l_m \times 10^4}{0.4 W_a J K}$$

From the equation

$$W_a A_c = \frac{2 (Eng) \times 10^4}{B_m J K}$$

two nomographs were generated to compare energy or $LI^2/2$ with $W_a A_c$ and energy or $LI^2/2$ with weight. These nomographs were generated for 13 commonly used powder cores in this article. The nomograph in Fig. 7 compares $LI^2/2$ with $W_a A_c$, thus the size of an inductor can quickly be determined. The nomograph in Fig. 8 compares $LI^2/2$ with weight, thus the weight of a fully wound inductor can quickly be determined. These nomographs have the following constraints:

$$B_m = 0.3 \text{ T}$$

$$J = 200 \text{ A/cm}^2$$

$$K = 0.4$$

After the core size has been determined the next step is to pick the right permeability for that core size and that is done with the following equation:

$$\mu_r = \frac{B_m l_m \times 10^4}{0.4\pi W_a J K}$$

More than likely after the permeability has been selected a slight reshuffle of the constraints to match the available core and permeability must be made.

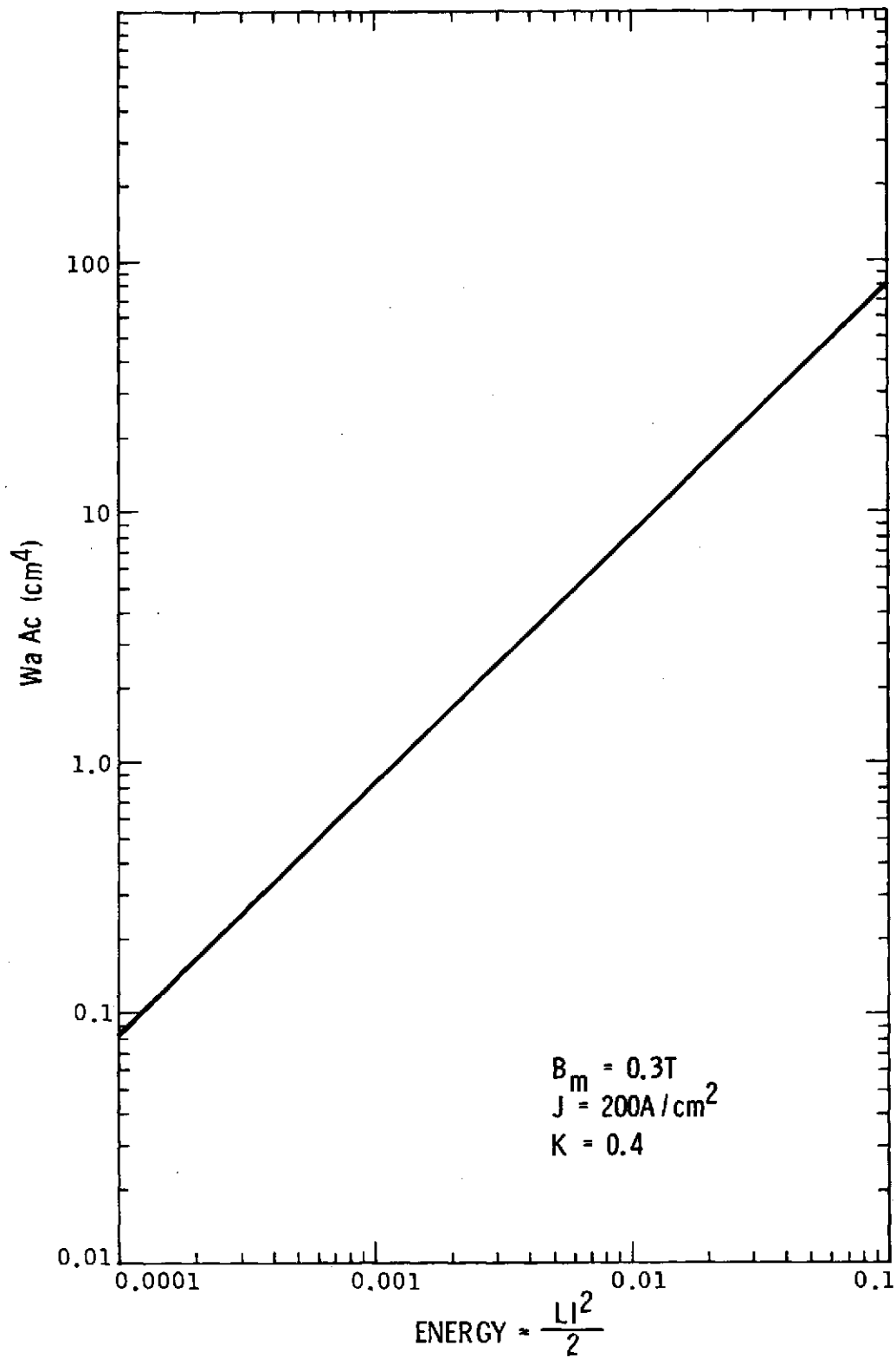

Fig. 7. Wa Ac versus $LI^2/2$

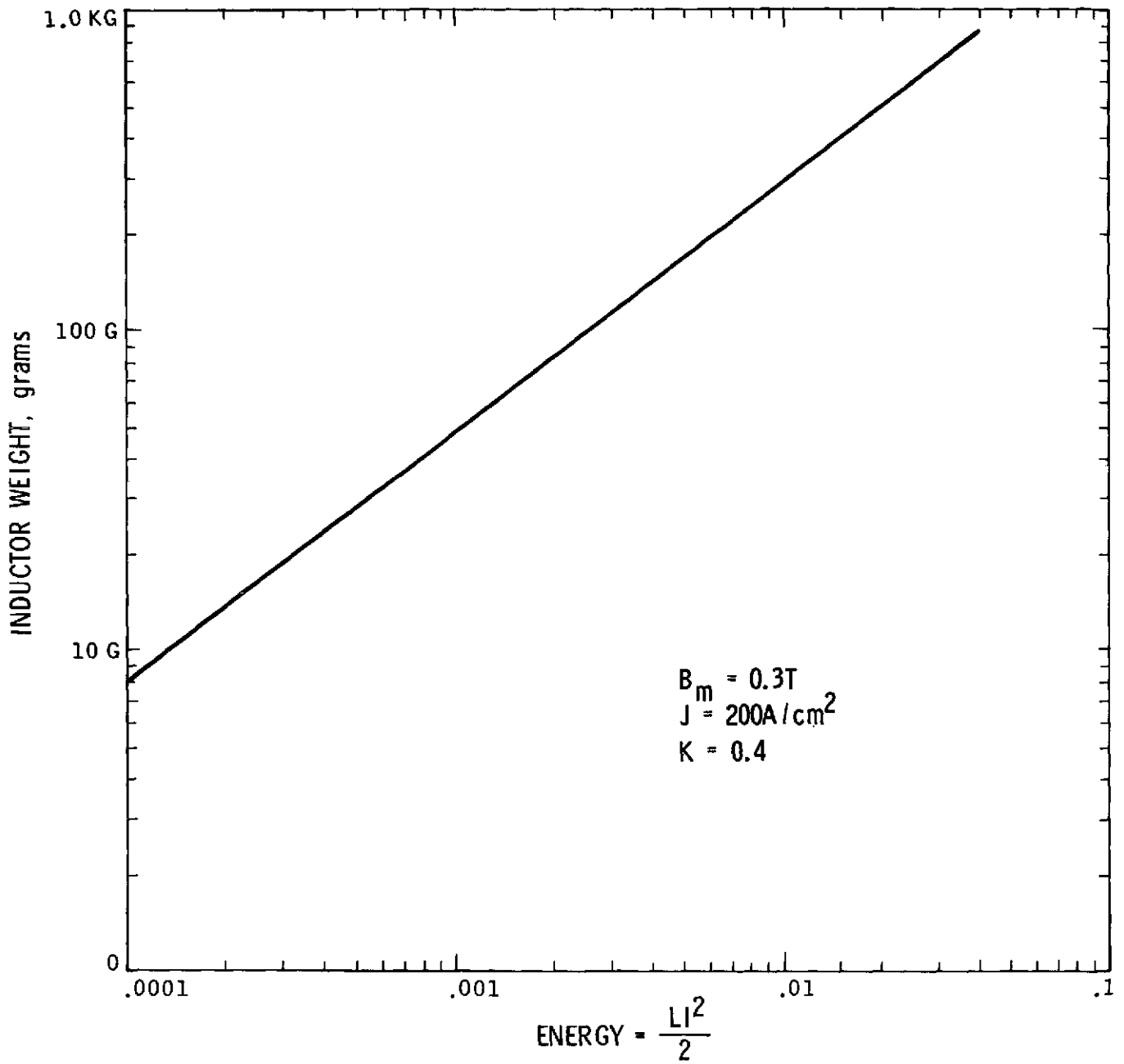

Fig. 8. Inductor Weight versus $LI^2/2$

VII. CALCULATION OF OUTSIDE DIAMETER OF WOUND TOROID

The outside diameter of the wound toroid, Fig. 9, (less the outside wrapper) may be calculated from (assuming one half of the ID remains after winding):

$$OD = \sqrt{D_2^2 (3/4) + D_3^2}$$

where:

D = diameter

$$A_1 = \pi(R_2^2 - R_1^2), A_1 = A_2$$

Core window ID = $D_1 = 2R_1$, Core ID = $D_2 = 2R_2$, Core OD = $D_3 = 2R_3$

$$\pi(R_2^2 - R_1^2) = \pi(R_4^2 - R_3^2), R_2^2 - R_1^2 = R_4^2 - R_3^2, R_1 = \frac{R_2}{2}$$

$$R_4^2 - R_3^2 = R_2^2 - \left(\frac{R_2}{2}\right)^2 = R_2^2 (1 - 1/4), R_4^2 = R_2^2 (3/4) + R_3^2$$

$$R_4 = \sqrt{R_2^2 (3/4) + R_3^2}$$

$$OD = 2R_4$$

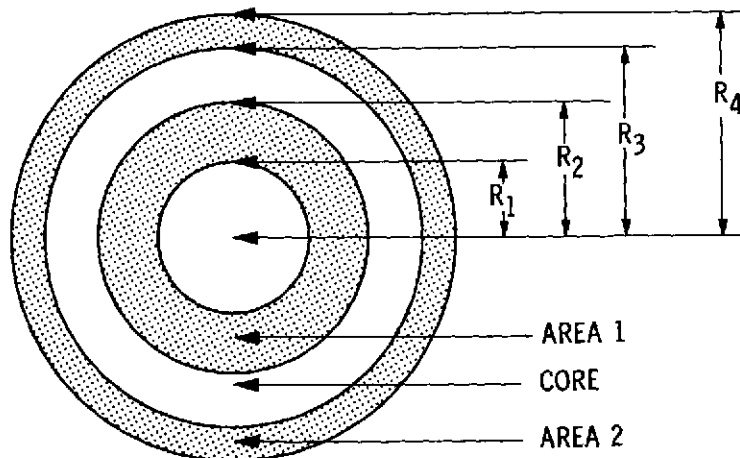

Fig. 9. Calculation of Outside Diameter of Wound Toroid

VIII. MAGNETIC AND DIMENSIONAL SPECIFICATIONS FOR THIRTEEN COMMONLY USED MOLYPERMALLOY CORES

The following remarks apply to each of Tables 3 to 15, the data in which was compiled from Ref. 2.

- (1) Total weight is core weight plus wire weight assuming AWG 20
- (2) Maximum OD of wound core with residual hole = 1/2 ID
- (3) MLT (mean length/turn), $K_2 \times K_3 = 0.6 \times 0.75 = 0.45$
- (4) Effective window area $W_{a \text{ eff}} = 3\pi r^2/4$

(Data was computed with the aid of Refs. 2 to 4.)

Nomographs (Figs. 10 to 22) relate to the thirteen different core sizes. The nomographs show resistance, number of turns, inductance and wire size for a fill factor of 0.45 ($K_2 \times K_3$), and are based on a permeability of 60. To convert for other permeability values, the appropriate inductance multiplication factors listed should be used. The information appearing in the tables and on the figures, will enable the engineer to arrive at a close approximation for breadboarding purposes.

PRECEDING PAGE BLANK NOT FILMED

Table 3. Magnetic Inc 55051-A2, Arnold Engineering A-051027-2

	ENGLISH	METRIC
W_a/A_c		3.39
$W_a \times A_c$	0.00104 in ⁴	0.0432 cm ⁴
OD	0.530 in	1.346 cm
ID	0.275 in	0.699 cm
HT	0.217 in	0.551 cm
$W_a =$ WINDOW AREA	0.075×10^6 CIR-MIL	0.383 cm ²
$W_a =$ EFFECTIVE	0.0445 in ²	0.288 cm ²
$A_c =$ CROSS SECTION	0.0175 in ²	0.113 cm ²
$l_m =$ PATH LENGTH	1.229 in	3.12 cm
CORE WEIGHT	0.0066 lb	3.0 grams
TOTAL WEIGHT	0.0106 lb	5.175 grams
WOUND OD MIN	0.581 in	1.475 cm
MLT	0.850 in	2.160 cm
$A_t =$ SURFACE AREA	1.018 in ²	6.568 cm ²
PERMEABILITY		60
μ 125		$2.08 \times L @ \mu 60$
μ 160		$2.67 \times L @ \mu 60$
μ 200		$3.33 \times L @ \mu 60$
μ 550		$9.17 \times L @ \mu 60$

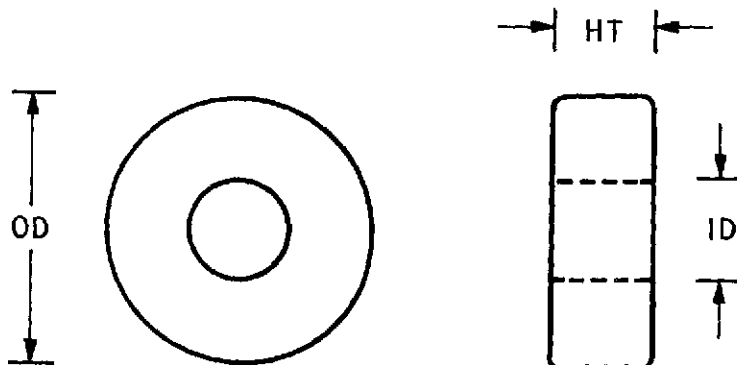

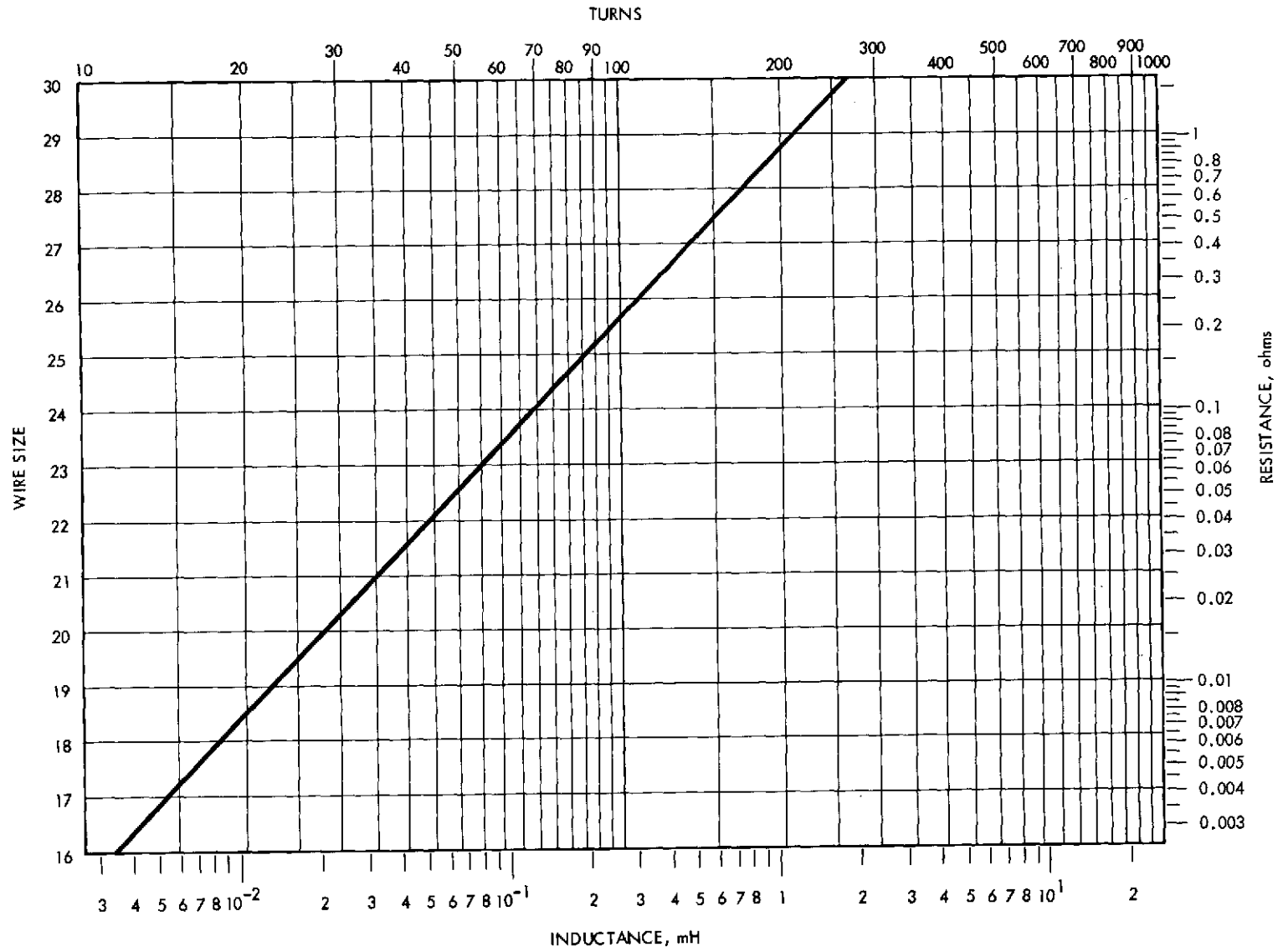
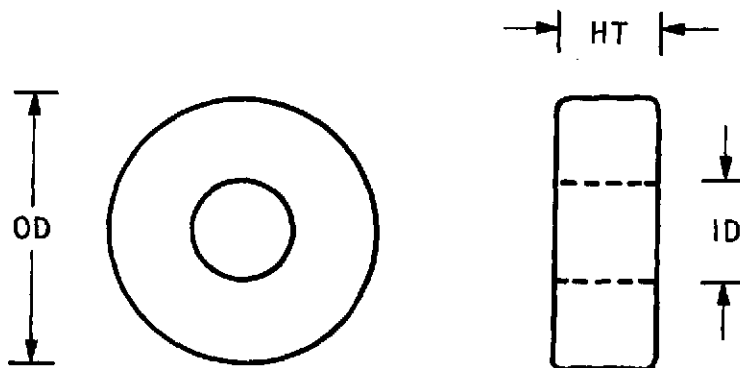

Fig. 10. Nomograph for Core 55051-A2

Table 4. Magnetic Inc 55121-A2, Arnold Engineering A-266036-2

	ENGLISH	METRIC
Wa/Ac		3.63
Wa x Ac	0.00336 in ⁴	0.139 cm ⁴
OD	0.680 in	1.740 cm
ID	0.375 in	0.953 cm
HT	0.280 in	0.711 cm
Wa = WINDOW AREA	0.141 x 10 ⁶ CIR-MIL	0.713 cm ²
Wa = EFFECTIVE	0.0828 in ²	0.535 cm ²
Ac = CROSS SECTION	0.0304 in ²	0.196 cm ²
lm = PATH LENGTH	1.62 in	4.11 cm
CORE WEIGHT	0.0143 lb	6.50 grams
TOTAL WEIGHT	0.0257 lb	11.70 grams
WOUND OD MIN	0.753 in	1.925 cm
MLT	1.075 in	2.74 cm
A _t = SURFACE AREA	1.742 in ²	11.24 cm ²
PERMEABILITY		60
μ 125		2.08 x L @ μ 60
μ 160		2.67 x L @ μ 60
μ 200		3.33 x L @ μ 60
μ 550		9.17 x L @ μ 60



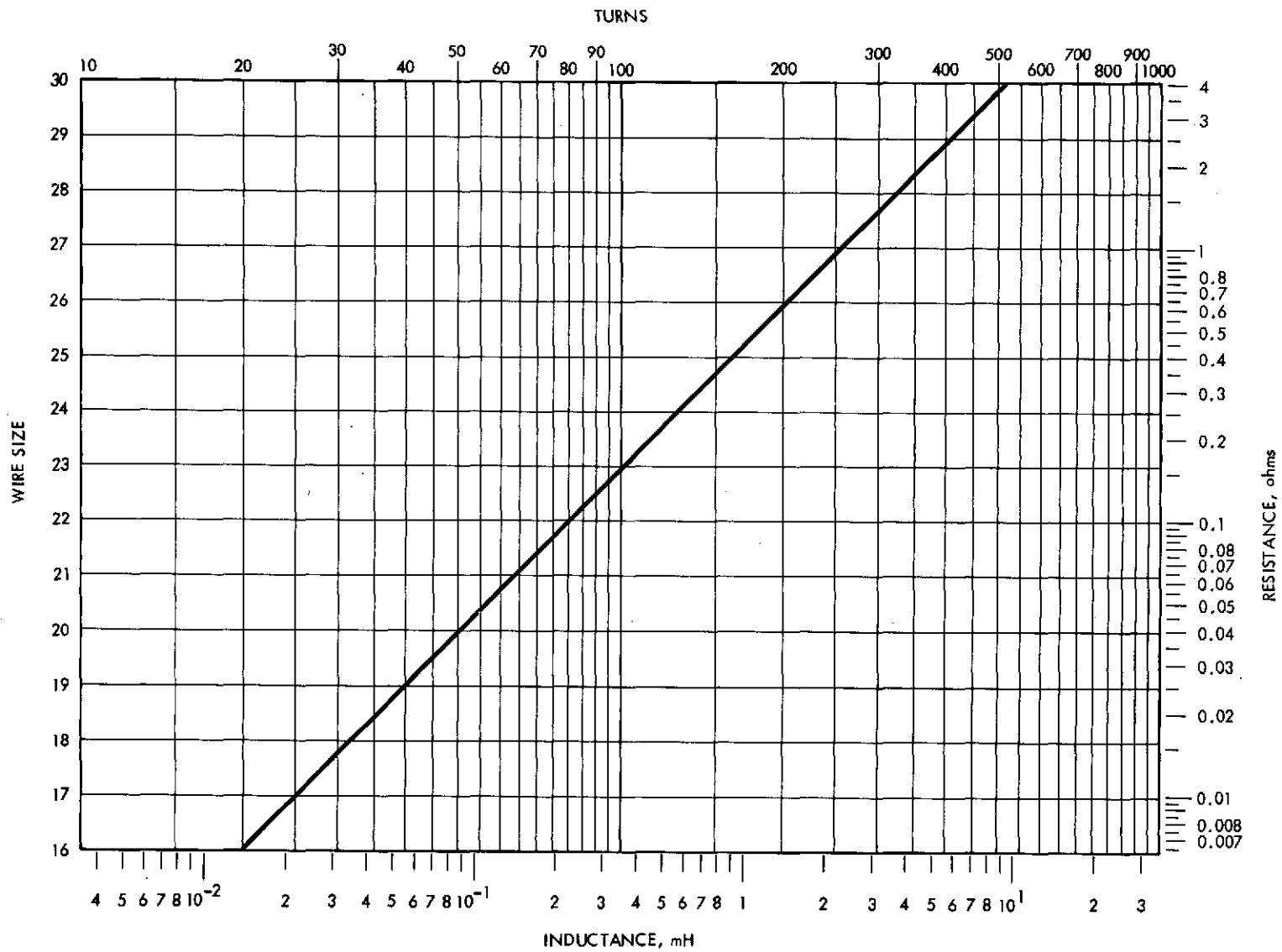
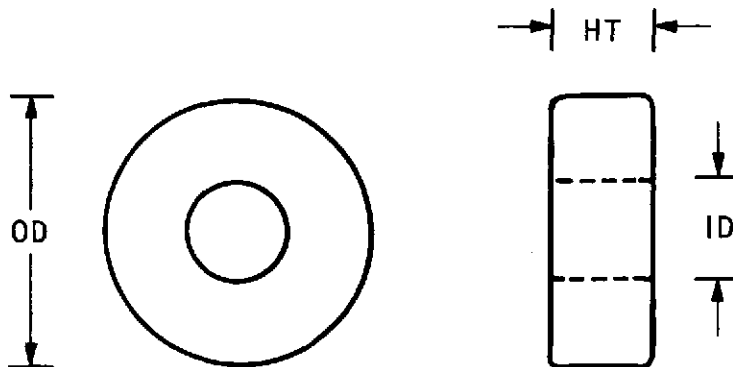

Fig. 11. Nomograph for Core 55121-A2

Table 5. Magnetic Inc 55848-A2, Arnold Engineering A-848032-2

	ENGLISH	METRIC
Wa/Ac		4.91
Wa x Ac	0.00636 in ⁴	0.264 cm ⁴
OD	0.830 in	2.11 cm
ID	0.475 in	1.21 cm
HT	0.280 in	0.711 cm
Wa = WINDOW AREA	0.23 x 10 ⁶ CIR-MIL	1.14 cm ²
Wa = EFFECTIVE	0.13290 in ²	0.858 cm ²
Ac = CROSS SECTION	0.036 in ²	0.232 cm ²
lm = PATH LENGTH	2.01 in	5.09 cm
CORE WEIGHT	0.021 lb	9.6 grams
TOTAL WEIGHT	0.041 lb	18.6 grams
WOUND OD MIN	0.926 in	2.35 cm
MLT	1.166 in	2.97 cm
A _t = SURFACE AREA	2.431 in ²	15.69 cm ²
PERMEABILITY		60
μ 125		2.08 x L @ μ 60
μ 160		2.67 x L @ μ 60
μ 200		3.33 x L @ μ 60
μ 550		9.17 x L @ μ 60



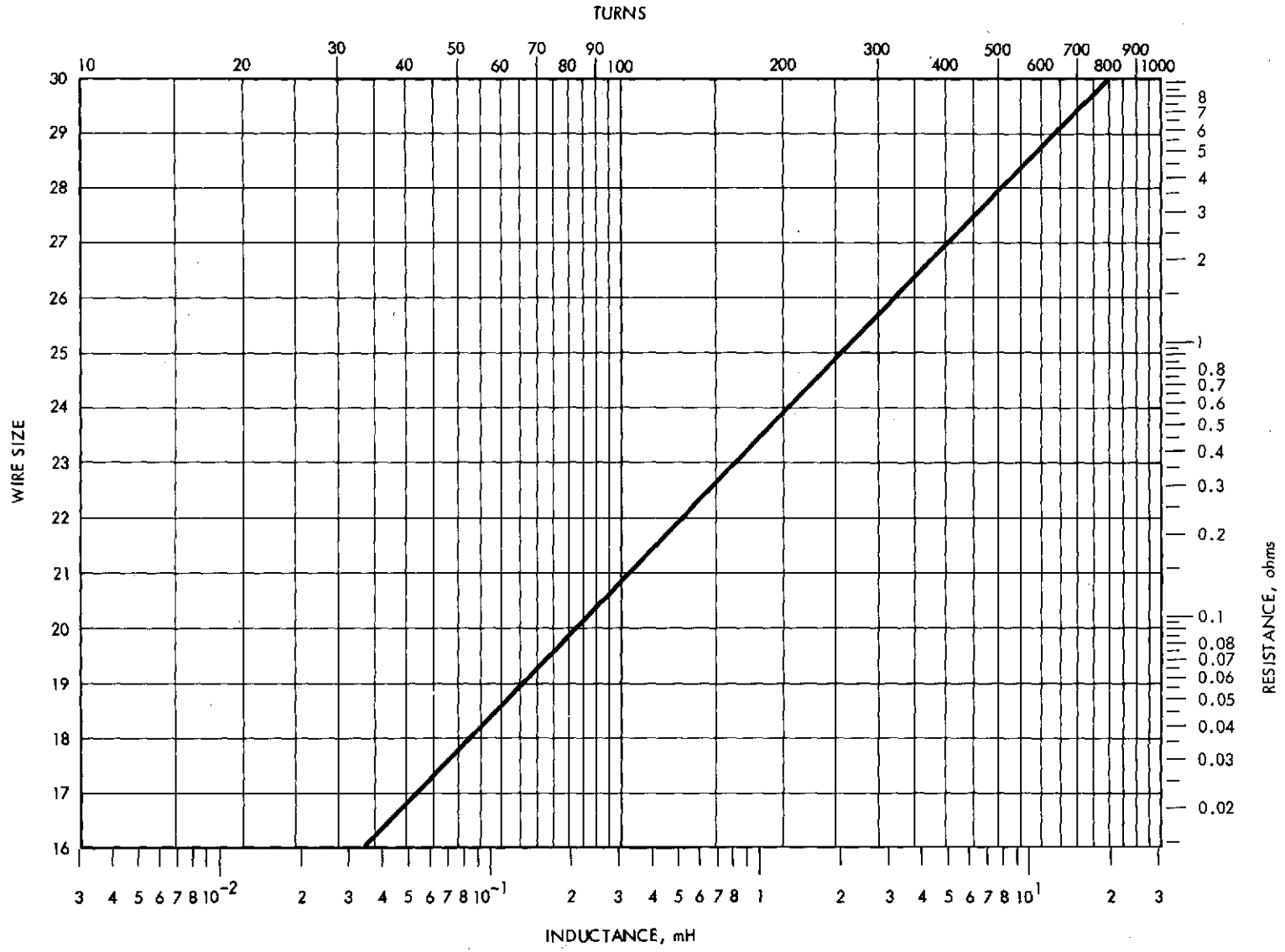
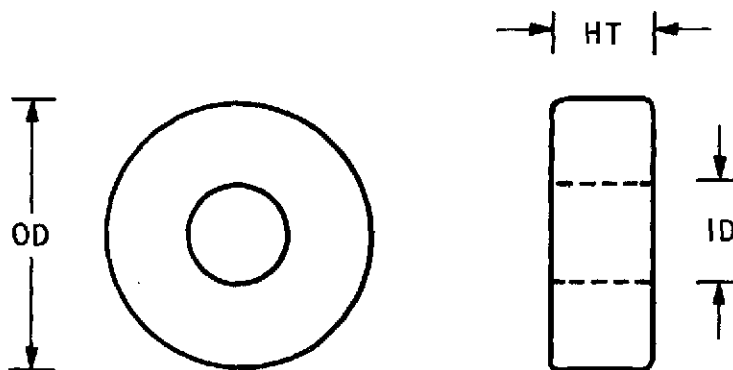

Fig. 12. Nomograph for Core 55848-A2

Table 6. Magnetic Inc 55059-A2, Arnold Engineering A-059043-2

	ENGLISH	METRIC
W_a/A_c		4.30
$W_a \times A_c$	0.0713 in ⁴	0.460 cm ⁴
OD	0.930 in	2.36 cm
ID	0.527 in	1.339 cm
HT	0.330 in	0.838 cm
$W_a =$ WINDOW AREA	0.28×10^6 CIR-MIL	1.407 cm ²
$W_a =$ EFFECTIVE	0.164 in ²	1.056 cm ²
$A_c =$ CROSS SECTION	0.0507 in ²	0.327 cm ²
$l_m =$ PATH LENGTH	2.23 in	5.67 cm
CORE WEIGHT	0.033 lb	15.0 grams
TOTAL WEIGHT	0.0716 lb	32.5 grams
WOUND OD MIN	1.035 in	2.63 cm
MLT	1.356 in	3.45 cm
$A_t =$ SURFACE AREA	3.103 in ²	20.019 cm ²
PERMEABILITY		60
μ 125		$2.08 \times L @ \mu 60$
μ 160		$2.67 \times L @ \mu 60$
μ 200		$3.33 \times L @ \mu 60$
μ 550		$9.17 \times L @ \mu 60$



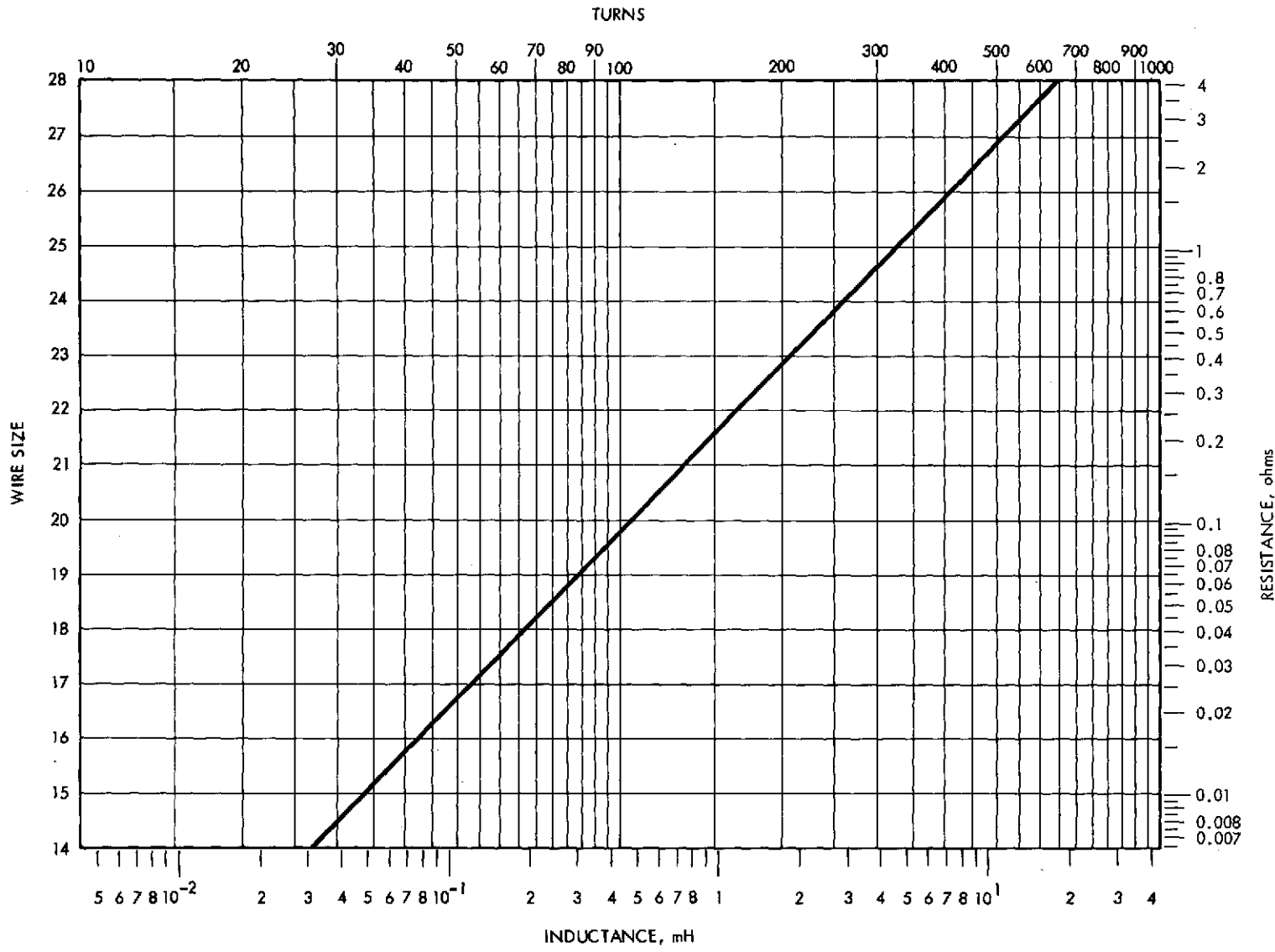
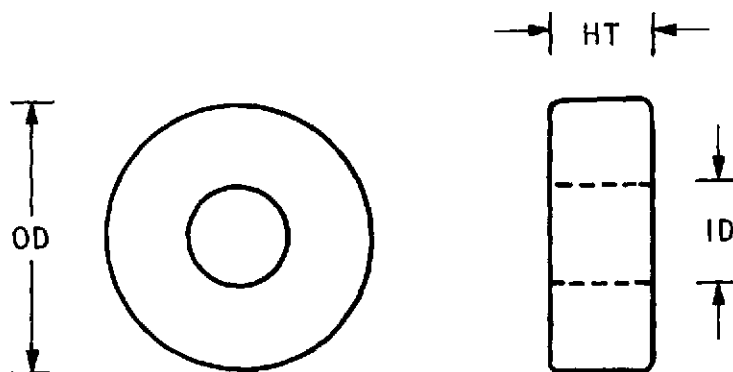

Fig. 13. Nomograph for Core 55059-A2

Table 7. Magnetic Inc 55894-A2, Arnold Engineering A-894075-2

	ENGLISH	METRIC
W_a/A_c		2.44
$W_a \times A_c$	0.0239 in ⁴	0.997 cm ⁴
OD	1.090 in	2.77 cm
ID	0.555 in	1.41 cm
HT	0.472 in	1.20 cm
$W_a =$ WINDOW AREA	0.31×10^6 CIR-MIL	1.561 cm ²
$W_a =$ EFFECTIVE	0.1814 in ²	1.17 cm ²
$A_c =$ CROSS SECTION	0.099 in ²	0.639 cm ²
$l_m =$ PATH LENGTH	2.50 in	6.35 cm
CORE WEIGHT	0.077 lb	35 grams
TOTAL WEIGHT	0.132 lb	59.7 grams
WOUND OD MIN	1.191 in	3.03 cm
MLT	1.81 in	4.61 cm
$A_t =$ SURFACE AREA	4.38 in ²	28.32 cm ²
PERMEABILITY		60
μ 125		$2.08 \times L @ \mu 60$
μ 160		$2.67 \times L @ \mu 60$
μ 200		$3.33 \times L @ \mu 60$
μ 550		$9.17 \times L @ \mu 60$



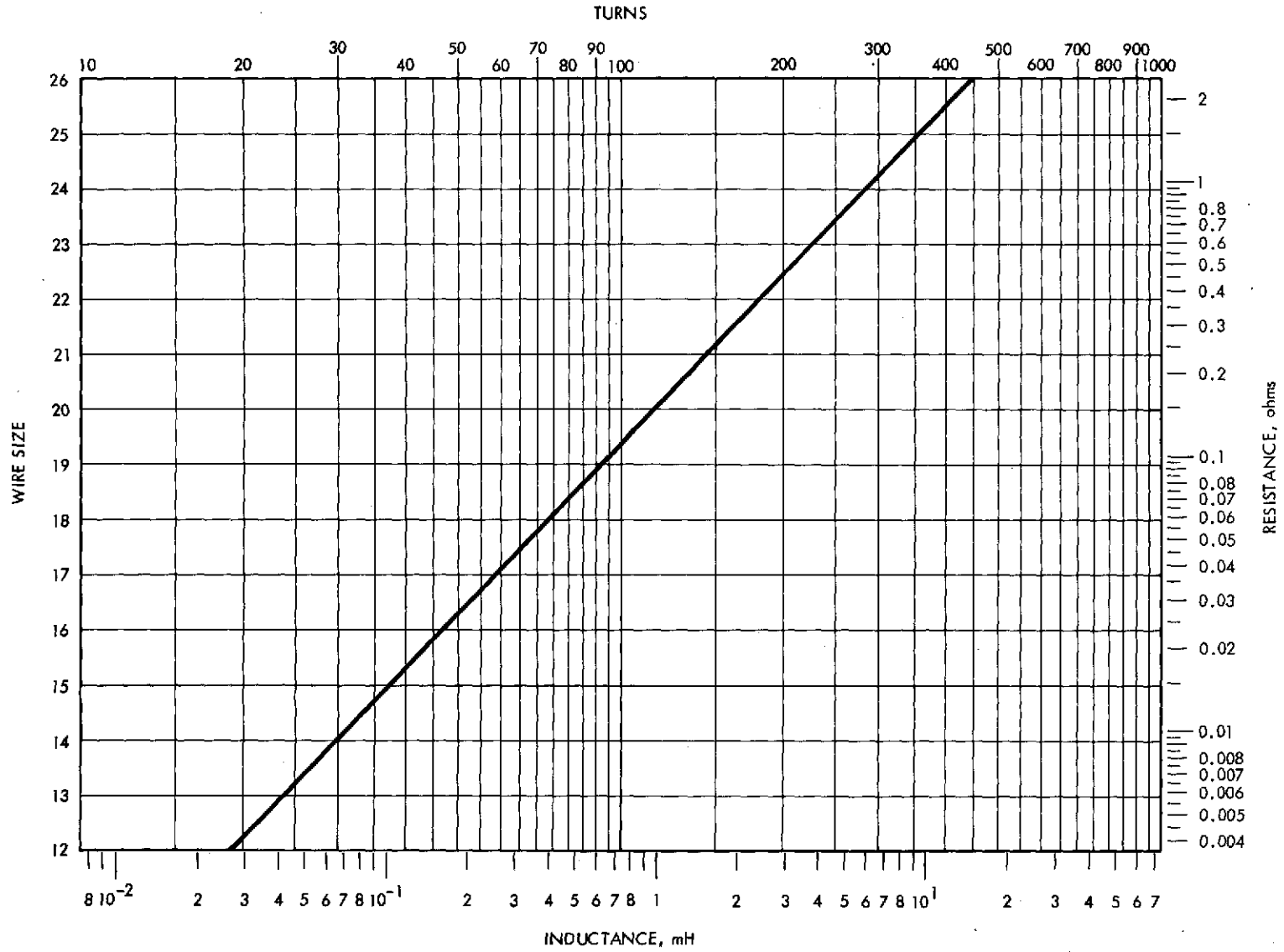
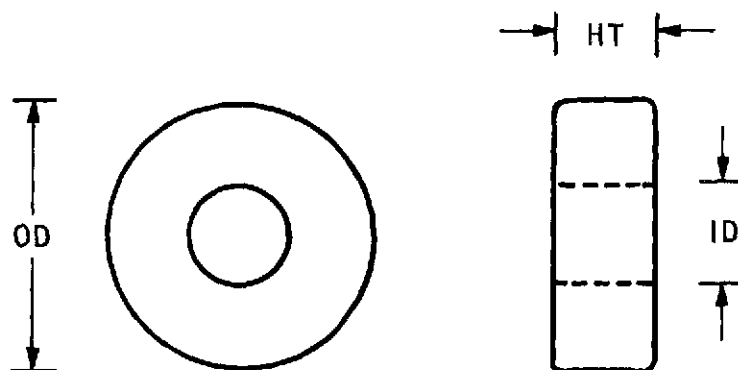

Fig. 14. Nomographs for Core 55894-A2

Table 8. Magnetic Inc 55071-A2, Arnold Engineering A-291061-2

	ENGLISH	METRIC
Wa/Ac		4.39
Wa x Ac	0.0468 in ⁴	1.95 cm ⁴
OD	1.332 in	3.38 cm
ID	0.760 in	1.93 cm
HT	0.457 in	1.16 cm
Wa = WINDOW AREA	0.58 x 10 ⁶ CIR-MIL	2.93 cm ²
Wa = EFFECTIVE	0.340 in ²	2.1941 cm ²
Ac = CROSS SECTION	0.1032 in ²	0.666 cm ²
lm = PATH LENGTH	3.21 in	8.15 cm
CORE WEIGHT	0.101 lb	46 grams
TOTAL WEIGHT	0.198 lb	90 grams
WOUND OD MIN	1.486 in	3.77 cm
MLT	1.89 in	4.80 cm
A _t = SURFACE AREA	4.389 in ²	40.68 cm ²
PERMEABILITY		60
μ 125		2.08 x L @ μ 60
μ 160		2.67 x L @ μ 60
μ 200		3.33 x L @ μ 60
μ 550		9.17 x L @ μ 60



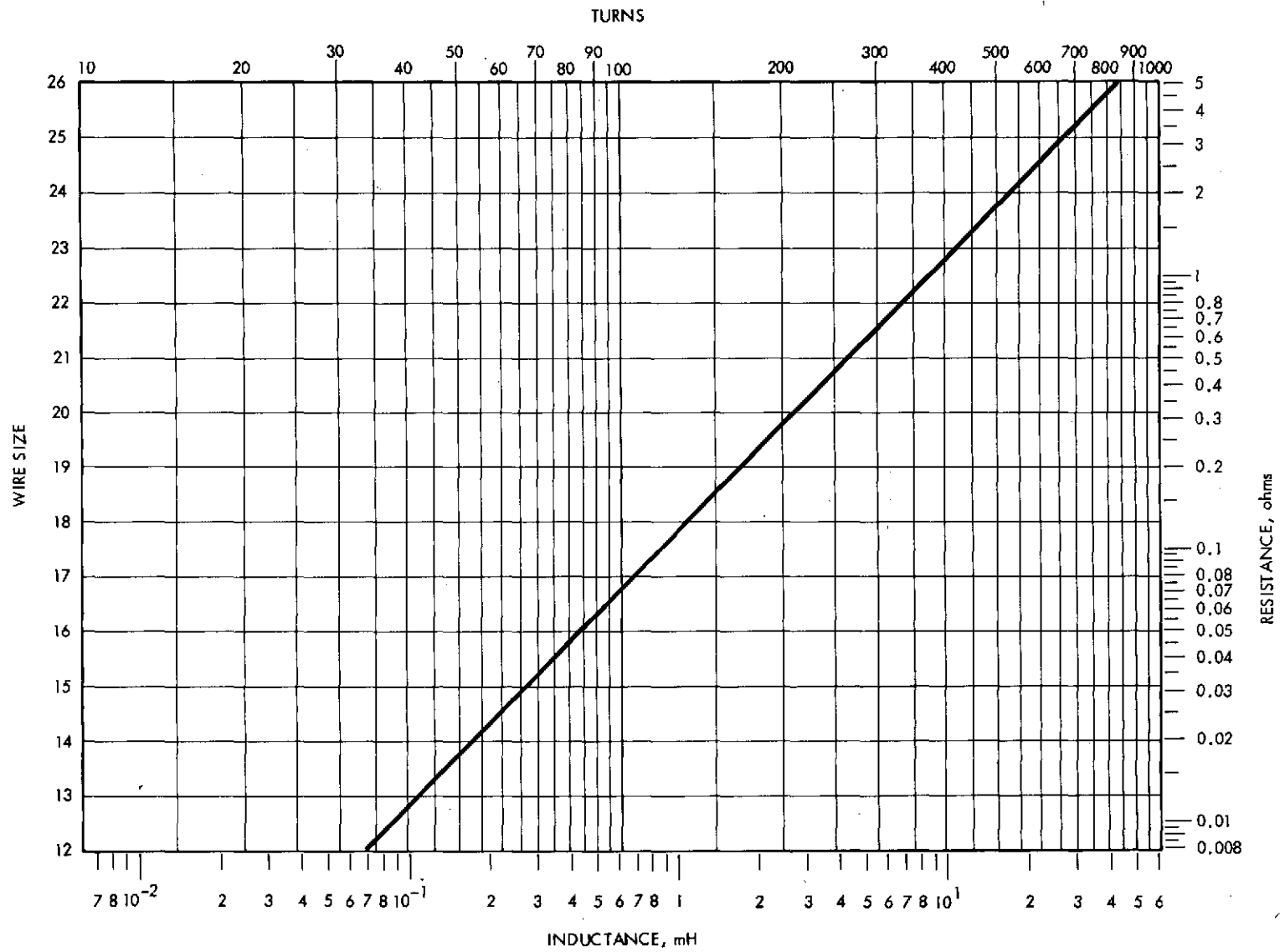
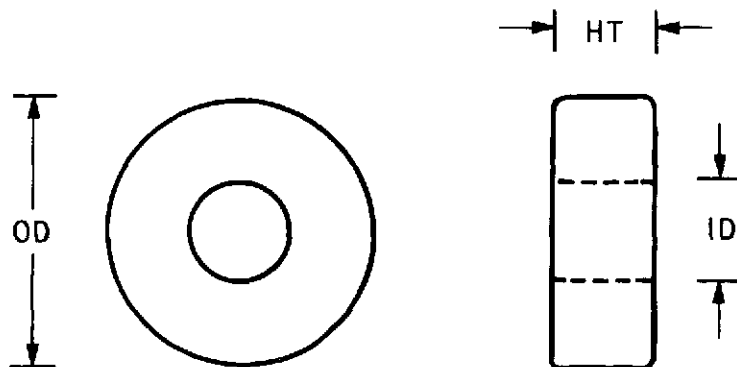

Fig. 15. Nomograph for Core 55071-A2

Table 9. Magnetic Inc 55586-A2, Arnold Engineering A-345038-2

	ENGLISH	METRIC
Wa/Ac		8.73
Wa x Ac	0.044 in ⁴	1.832 cm ⁴
OD	1.382 in	3.51 cm
ID	0.888 in	2.26 cm
HT	0.387 in	0.983 cm
Wa = WINDOW AREA	0.79 x 10 ⁶ CIR-MIL	4.00 cm ²
Wa = EFFECTIVE	0.4644 in ²	3.009 cm ²
Ac = CROSS SECTION	0.0710 in ²	0.458 cm ²
lm = PATH LENGTH	3.53 in	8.95 cm
CORE WEIGHT	0.075 lb	34 grams
TOTAL WEIGHT	0.193 lb	87.4 grams
WOUND OD MIN	1.58 in	4.02 cm
MLT	1.70 in	4.32 cm
A _t = SURFACE AREA	6.85 in ²	44.24 cm ²
PERMEABILITY		60
μ 125		2.08 x L @ μ 60
μ 160		2.67 x L @ μ 60
μ 200		3.33 x L @ μ 60
μ 550		9.17 x L @ μ 60



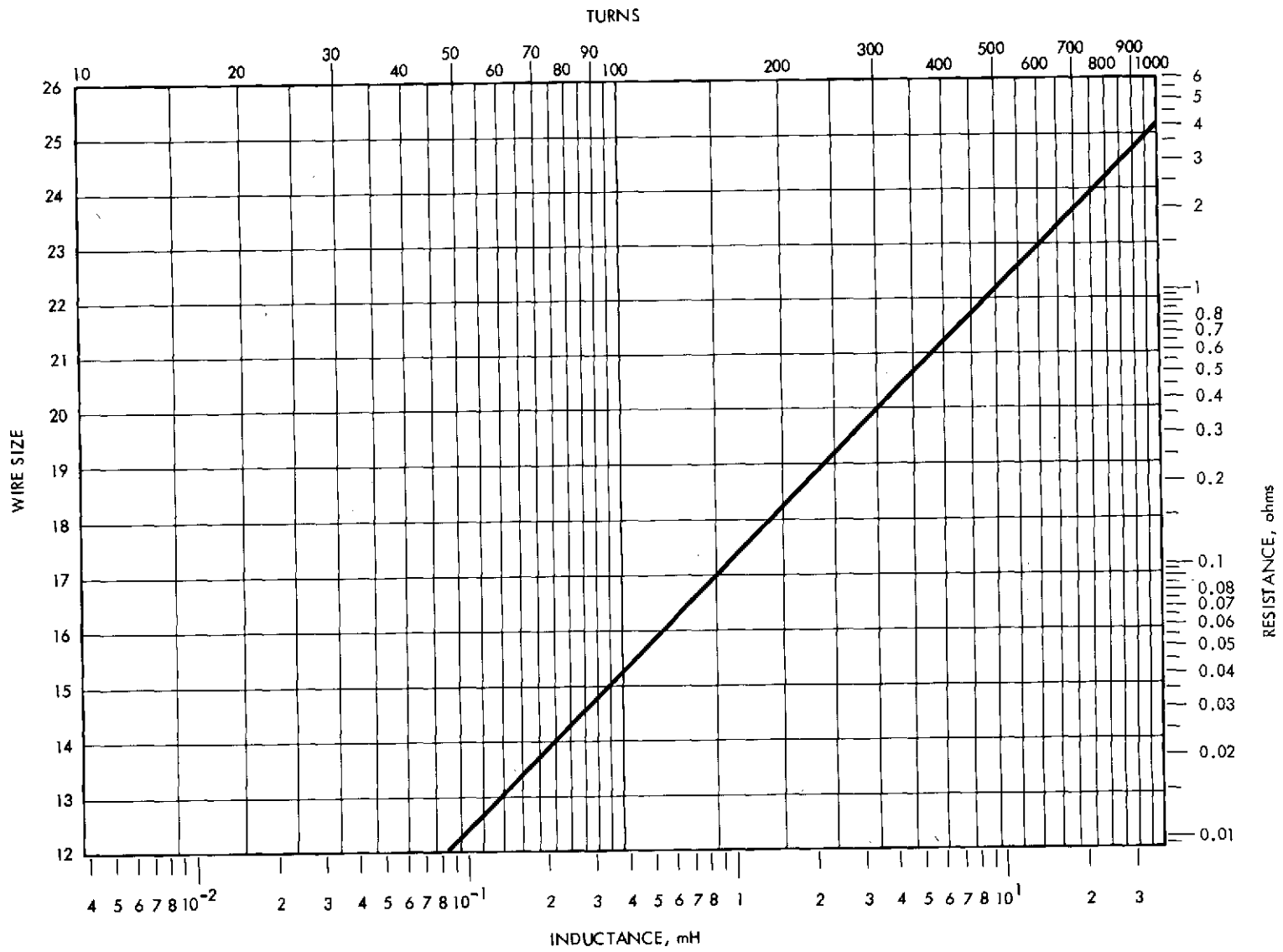
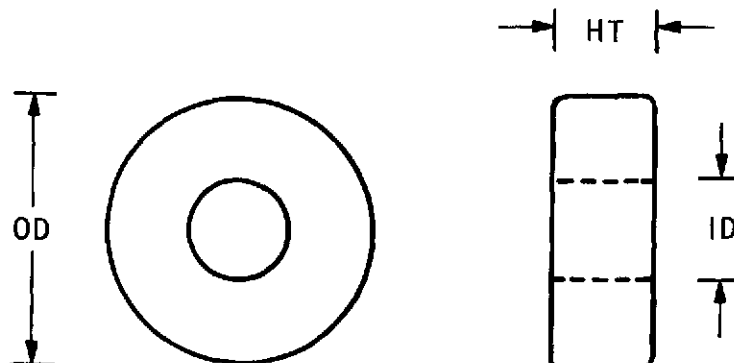

Fig 16. Nomograph for Core 55586-A2

Table 10. Magnetic Inc 55076-A2, Arnold Engineering A-076056-2

	ENGLISH	METRIC
Wa/Ac		5.43
Wa x Ac	0.0586 in ⁴	2.44 cm ⁴
OD	1.44 in	3.66 cm
ID	0.848 in	2.15 cm
HT	0.444 in	1.128 cm
Wa = WINDOW AREA	0.72 x 10 ⁶ CIR-MIL	3.64 cm ²
Wa = EFFECTIVE	0.424 in ²	2.723 cm ²
Ac = CROSS SECTION	0.1039 in ²	0.670 cm ²
lm = PATH LENGTH	3.54 in	8.98 cm
CORE WEIGHT	0.112 lb	51 grams
TOTAL WEIGHT	0.239 lb	108.4 grams
WOUND OD MIN	1.62 in	4.11 cm
MLT	1.91 in	4.88 cm
A _t = SURFACE AREA	7.271 in ²	46.91 cm ²
PERMEABILITY		60
μ 125		2.08 x L @ μ 60
μ 160		2.67 x L @ μ 60
μ 200		3.33 x L @ μ 60
μ 550		9.17 x L @ μ 60



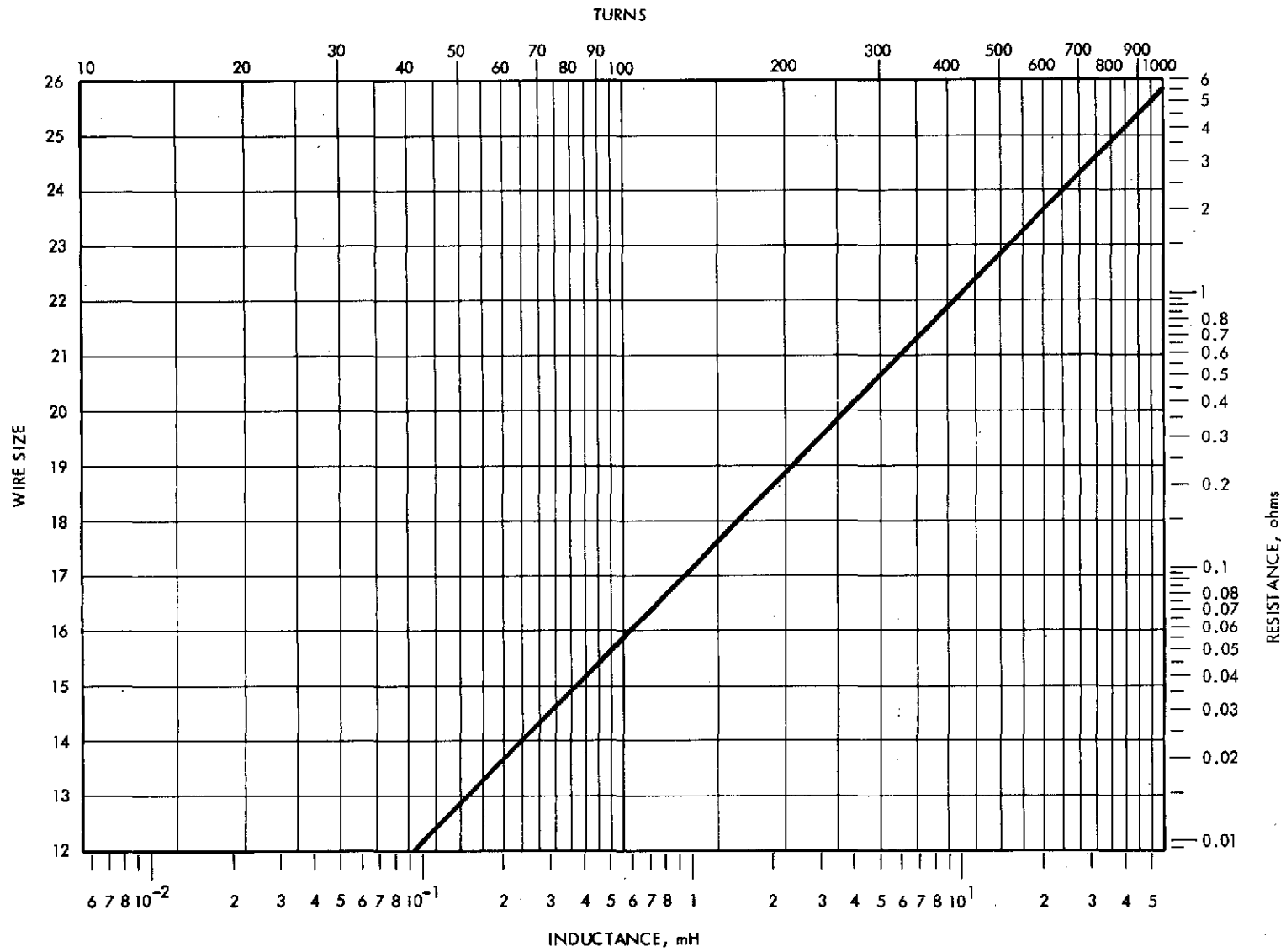
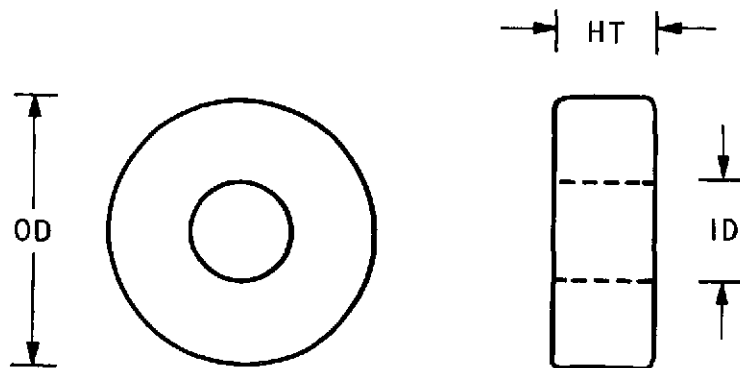

Fig. 17. Nomograph for Core 55076-A2

Table 11. Magnetic Inc 55083-A2, Arnold Engineering A-083081-2

	ENGLISH	METRIC
W_a/A_c		4.02
$W_a \times A_c$	0.108 in ⁴	4.53 cm ⁴
OD	1.602 in	4.07 cm
ID	0.918 in	2.33 cm
HT	0.605 in	1.54 cm
$W_a =$ WINDOW AREA	0.84×10^6 CIR-MIL	4.27 cm ²
$W_a =$ EFFECTIVE	0.496 in ²	3.198 cm ²
$A_c =$ CROSS SECTION	0.164 in ²	1.06 cm ²
$l_m =$ PATH LENGTH	3.88 in	9.84 cm
CORE WEIGHT	0.198 lb	90 grams
TOTAL WEIGHT	0.388 lb	176 grams
WOUND OD MIN	1.79 in	4.54 cm
MLT	2.36 in	6.07 cm
$A_t =$ SURFACE AREA	9.46 in ²	61.05 cm ²
PERMEABILITY		60
μ 125		2.08 x L @ μ 60
μ 160		2.67 x L @ μ 60
μ 200		3.33 x L @ μ 60
μ 550		9.17 x L @ μ 60



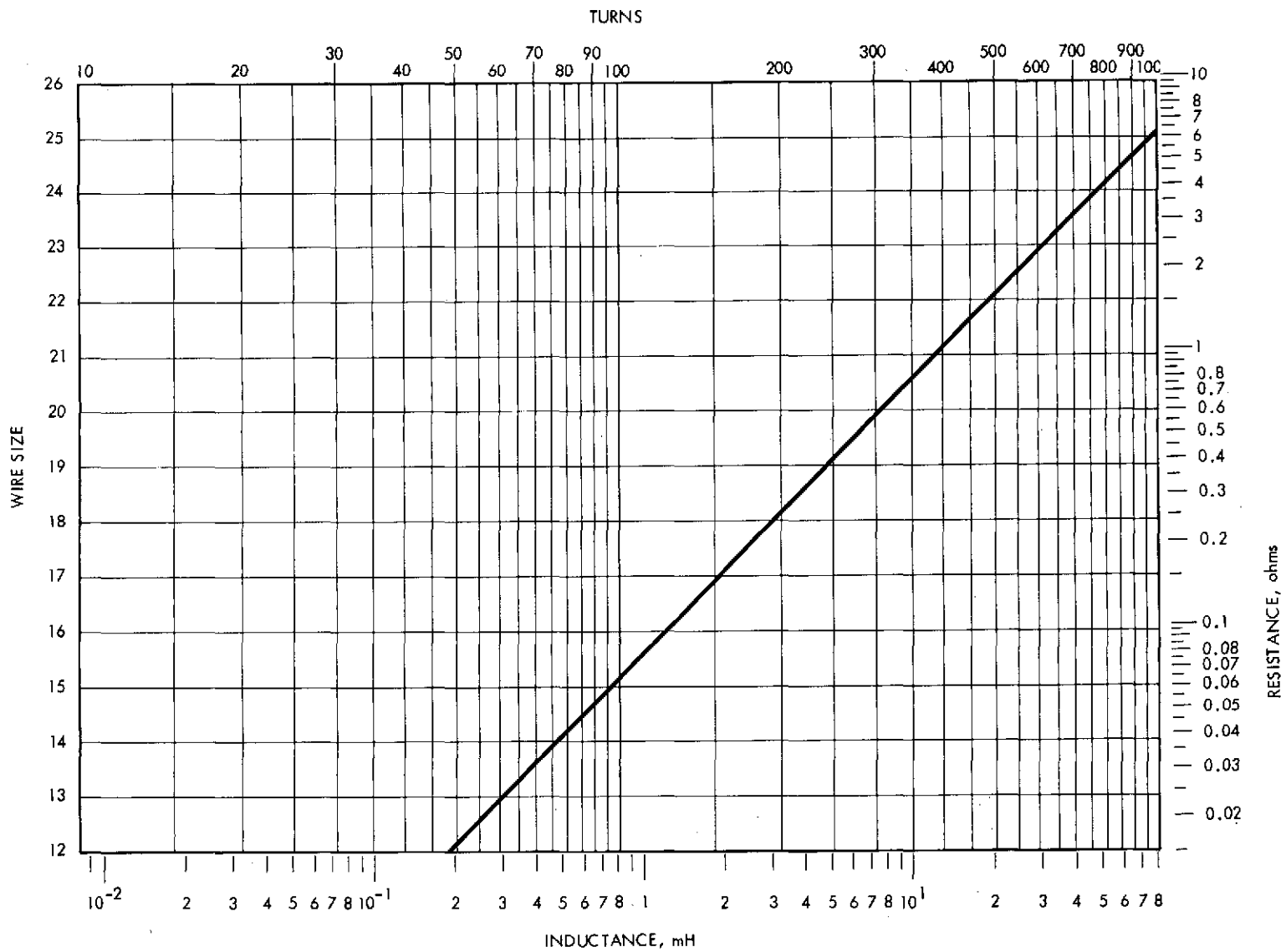
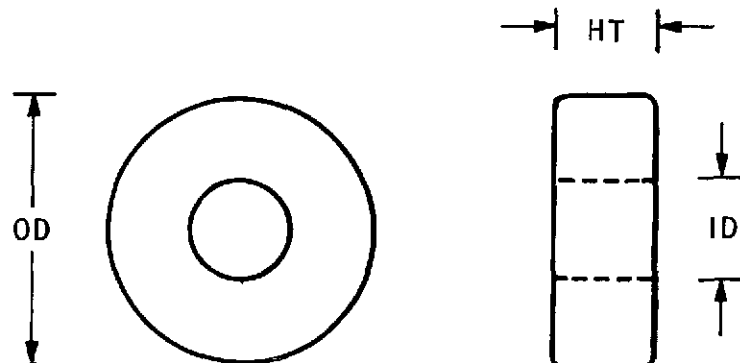

Fig. 18. Nomograph for Core 55083-A2

Table 12. Magnetic Inc 55439-A2, Arnold Engineering A-759135-2

	ENGLISH	METRIC
W_a/A_c		2.19
$W_a \times A_c$	0.200 in ⁴	8.33 cm ⁴
OD	1.875 in	4.76 cm
ID	0.918 in	2.33 cm
HT	0.745 in	1.89 cm
$W_a =$ WINDOW AREA	0.84×10^6 CIR-MIL	4.27 cm ²
$W_a =$ EFFECTIVE	0.496 in ²	3.198 cm ²
$A_c =$ CROSS SECTION	0.302 in ²	1.95 cm ²
$l_m =$ PATH LENGTH	4.23 in	10.74 cm
CORE WEIGHT	0.346 lb	180 grams
TOTAL WEIGHT	0.641 lb	291 grams
WOUND OD MIN	2.04 in	5.17 cm
MLT	3.00 in	7.62 cm
$A_t =$ SURFACE AREA	12.30 in ²	79.37 cm ²
PERMEABILITY		60
μ 125		$2.08 \times L @ \mu 60$
μ 160		$2.67 \times L @ \mu 60$
μ 200		$3.33 \times L @ \mu 60$
μ 550		$9.17 \times L @ \mu 60$



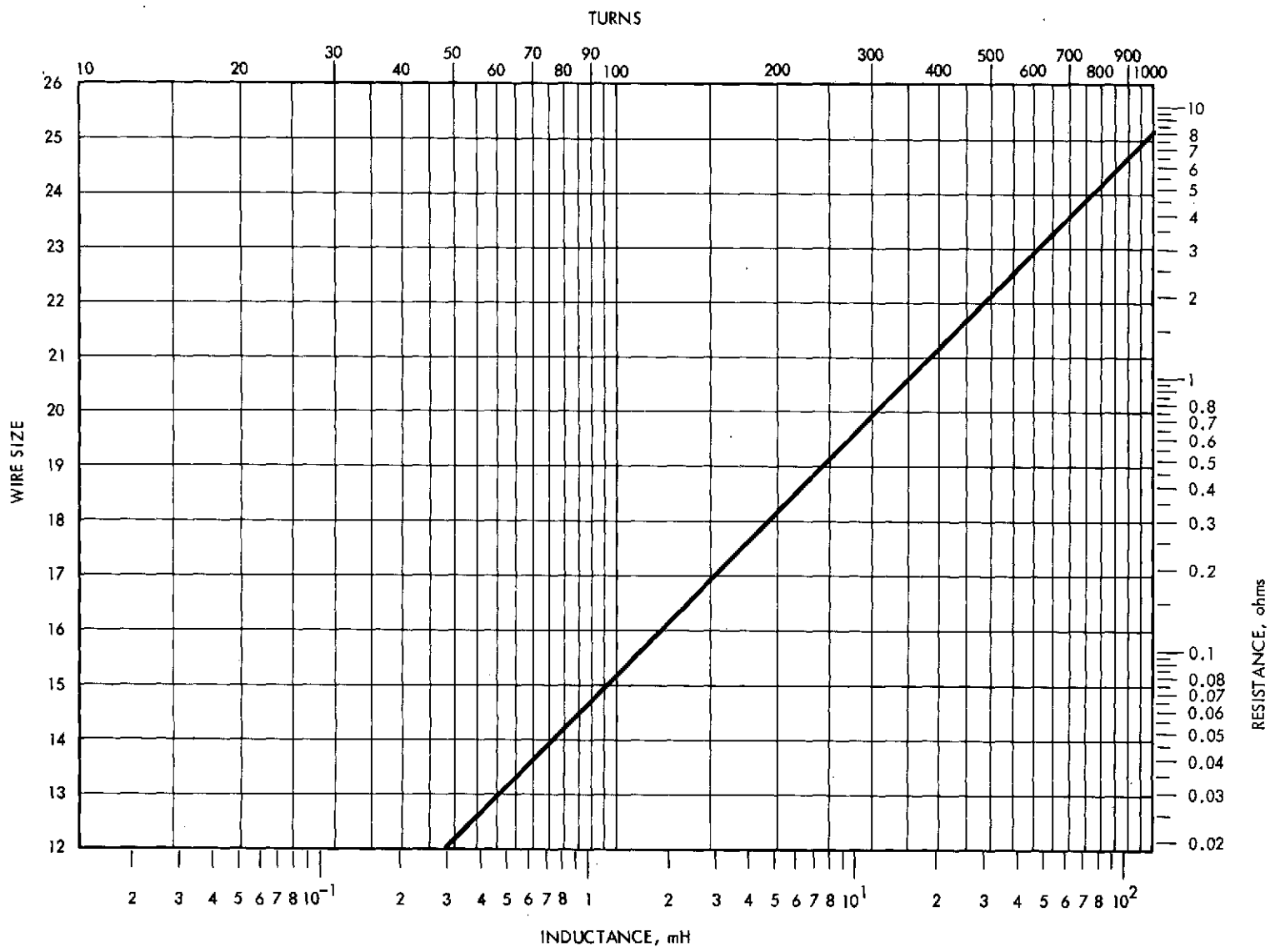
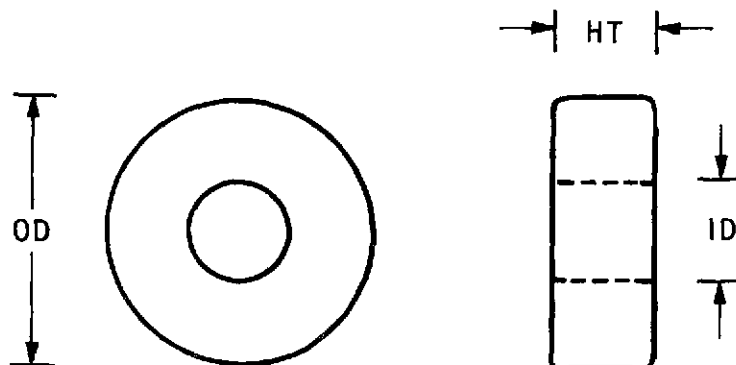

Fig. 19. Nomograph for Core 55439-A2

Table 13. Magnetic Inc 55090-A2, Arnold Engineering A-090086-2

	ENGLISH	METRIC
Wa/Ac		4.63
Wa x Ac	0.194 in ⁴	8.06 cm ⁴
OD	1.875 in	4.76 cm
ID	1.098 in	2.79 cm
HT	0.635 in	1.61 cm
Wa = WINDOW AREA	1.21 x 10 ⁶ CIR-MIL	6.11 cm ²
Wa = EFFECTIVE	0.710 in ²	4.58 cm ²
Ac = CROSS SECTION	0.205 in ²	1.32 cm ²
lm = PATH LENGTH	4.58 in	11.62 cm
CORE WEIGHT	0.286 lb	130 grams
TOTAL WEIGHT	0.588 lb	267 grams
WOUND OD MIN	2.10 in	5.34 cm
MLT	2.62 in	6.66 cm
A _t = SURFACE AREA	12.64 in ²	81.58 cm ²
PERMEABILITY		60
μ 125		2.08 x L @ μ 60
μ 160		2.67 x L @ μ 60
μ 200		3.33 x L @ μ 60
μ 550		9.17 x L @ μ 60



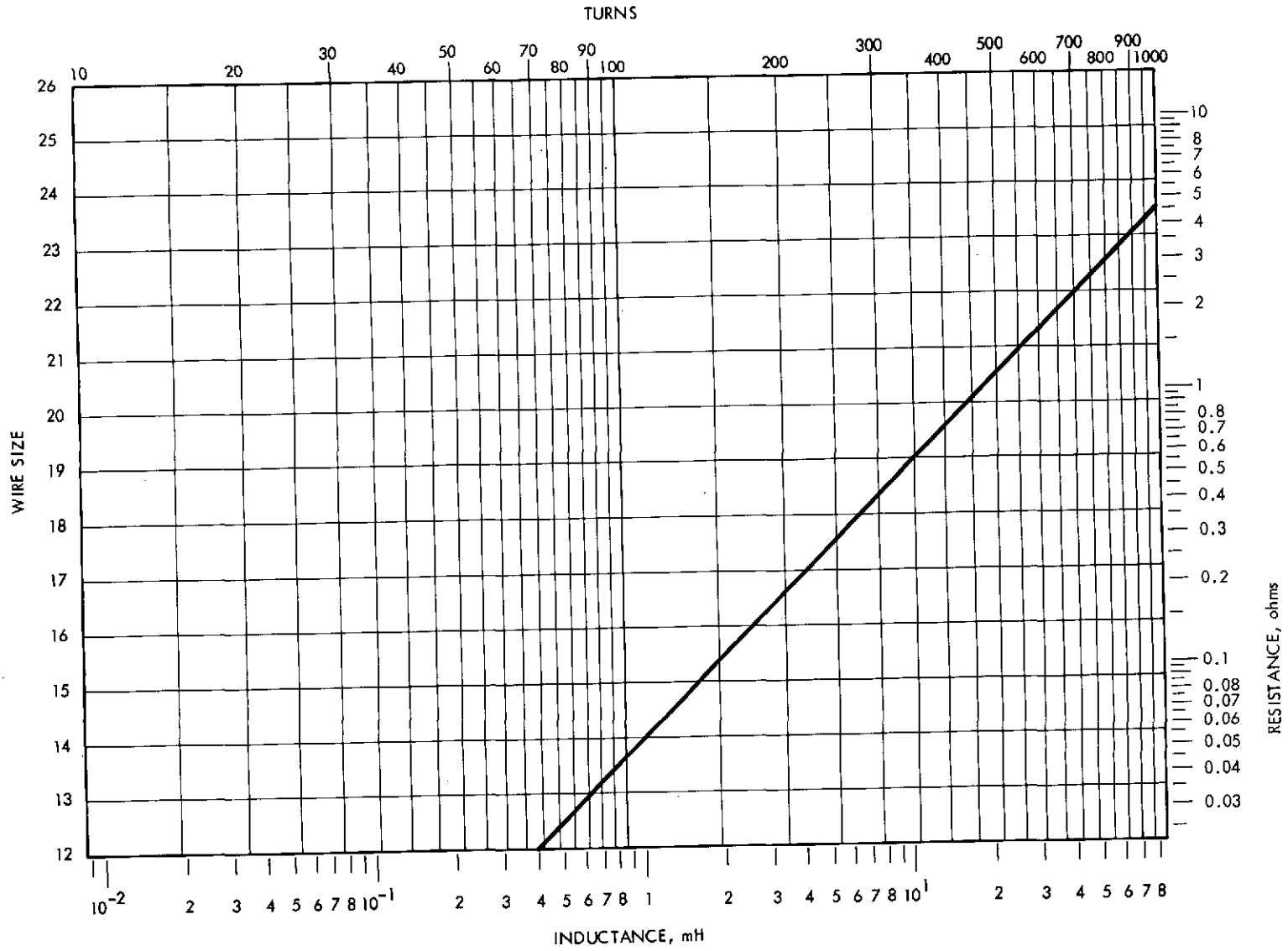
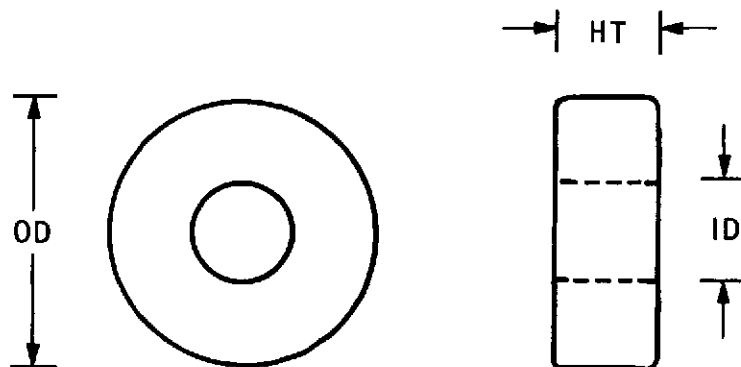

Fig. 20. Nomograph for Core 55090-A2

Table 14. Magnetic Inc 55716-A2, Arnold Engineering A-106073-2

	ENGLISH	METRIC
Wa/Ac		6.06
Wa x Ac	0.224 in ⁴	9.32 cm ⁴
OD	2.035 in	5.17 cm
ID	1.218 in	3.09 cm
HT	0.565 in	1.435 cm
Wa = WINDOW AREA	1.48 x 10 ⁶ CIR-MIL	7.52 cm ²
Wa = EFFECTIVE	0.874 in ²	5.62 cm ²
Ac = CROSS SECTION	0.192 in ²	1.24 cm ²
lm = PATH LENGTH	5.02 in	12.73 cm
CORE WEIGHT	0.298 lb	135 grams
TOTAL WEIGHT	0.652 lb	296 grams
WOUND OD MIN	2.29 in	5.82 cm
MLT	2.55 in	6.50 cm
A _t = SURFACE AREA	14.15 in ²	91.32 cm ²
PERMEABILITY		60
μ 125		2.08 x L @ μ 60
μ 160		2.67 x L @ μ 60
μ 200		3.33 x L @ μ 60
μ 550		9.17 x L @ μ 60



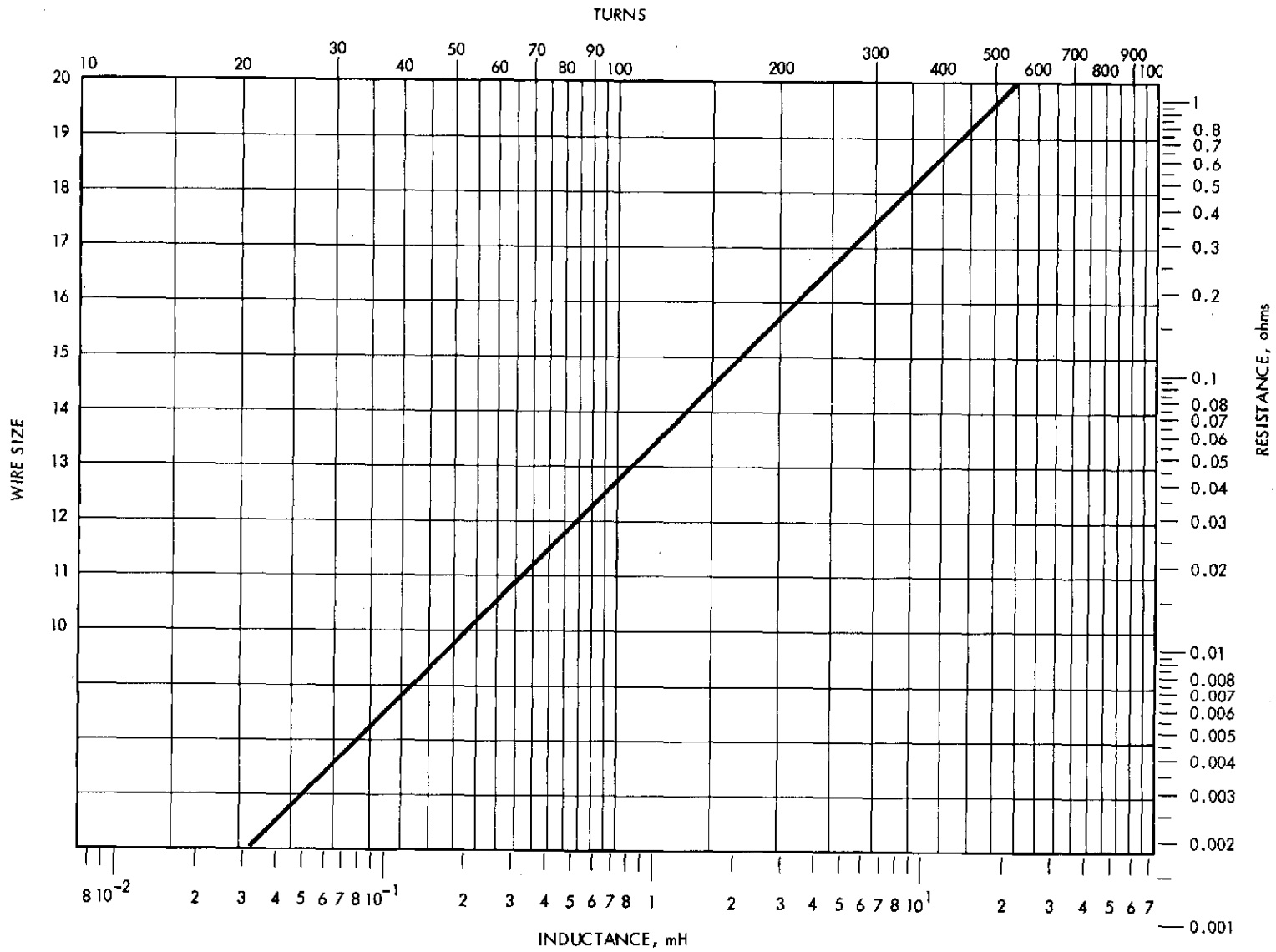
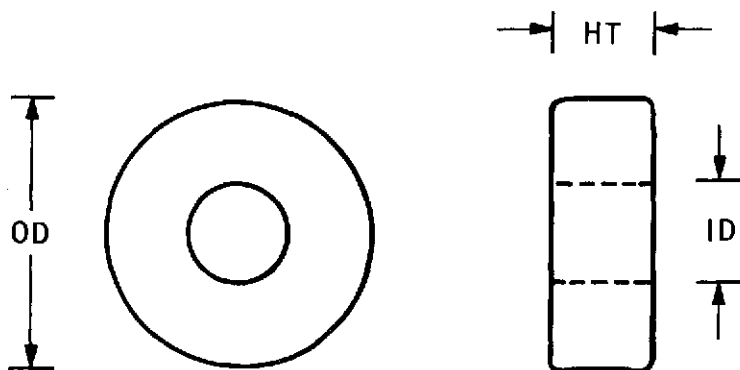

Fig. 21. Nomograph for Core 55716-A2

Table 15. Magnetic Inc 55110-A2, Arnold Engineering A-488075-2

	ENGLISH	METRIC
W_a/A_c		6.58
$W_a \times A_c$	0.328 in ⁴	13.65 cm ⁴
OD	2.285 in	5.8 cm
ID	1.368 in	3.47 cm
HT	0.585 in	1.486 cm
$W_a =$ WINDOW AREA	1.87×10^6 CIR-MIL	9.48 cm ²
$W_a =$ EFFECTIVE	1.1023 in ²	7.093 cm ²
$A_c =$ CROSS SECTION	0.223 in ²	1.44 cm ²
$l_m =$ PATH LENGTH	5.63 in	14.30 cm
CORE WEIGHT	0.385 lb	175 grams
TOTAL WEIGHT	0.864 lb	392 grams
WOUND OD MIN	2.57 in	6.53 cm
MLT	2.75 in	7.00 cm
$A_t =$ SURFACE AREA	17.42 in ²	112.4 cm ²
PERMEABILITY		60
μ 125		$2.08 \times L @ \mu 60$
μ 160		$2.67 \times L @ \mu 60$
μ 200		$3.33 \times L @ \mu 60$
μ 550		$9.17 \times L @ \mu 60$



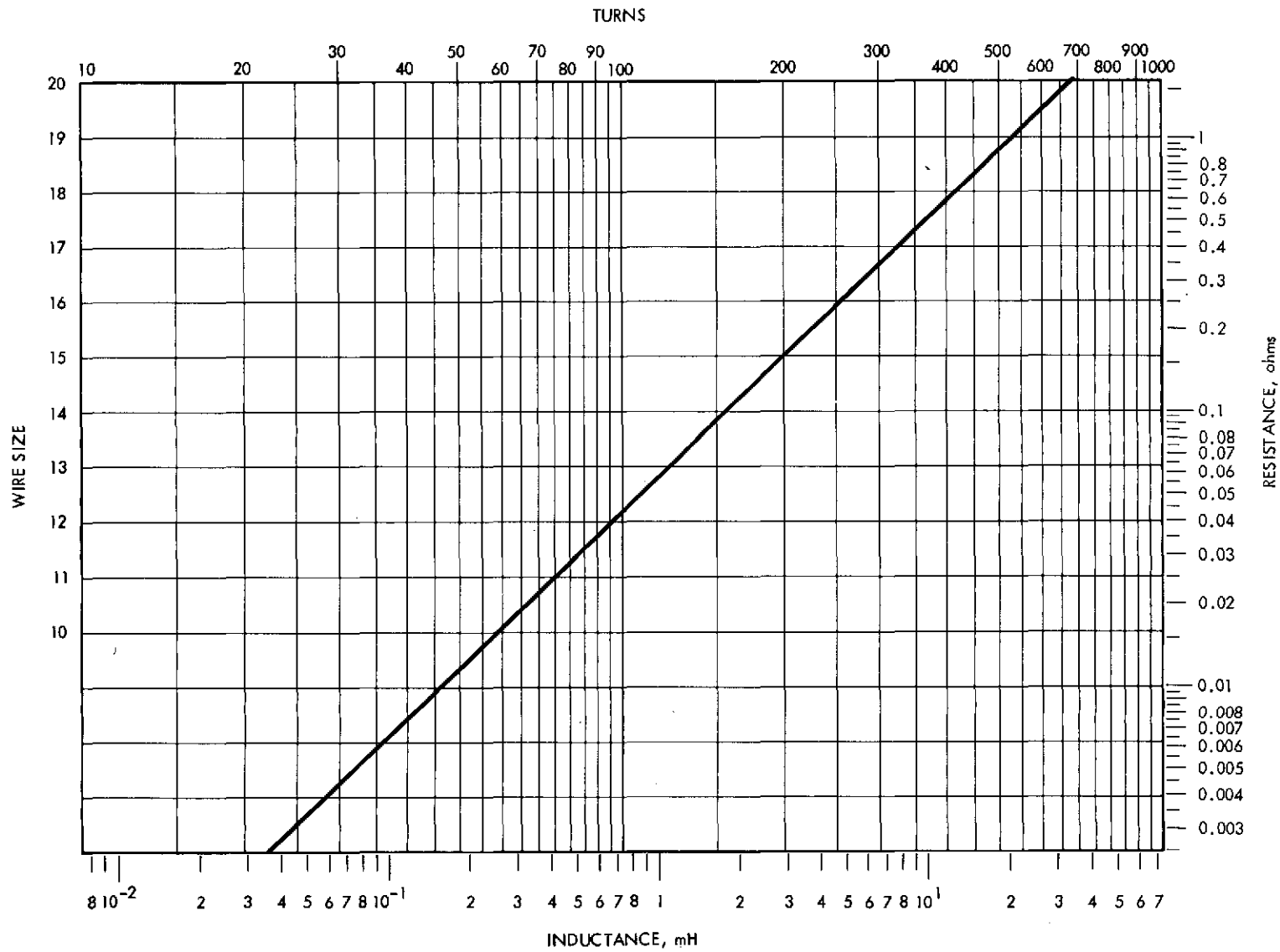

Fig. 22. Nomograph for Core 55110-A2

IX. CORE LOSS FOR MOLYPERMALLOY POWDER CORES

Figure 23 depicts core loss curves for molypermalloy powder cores. These curves were obtained from Magnetics Inc., and are believed to be more typical curves for 60μ to 200μ than the data previously published in its catalog. Many catalogs state core loss in ohms per millihenry. Here it is expressed in milliwatts per gram.

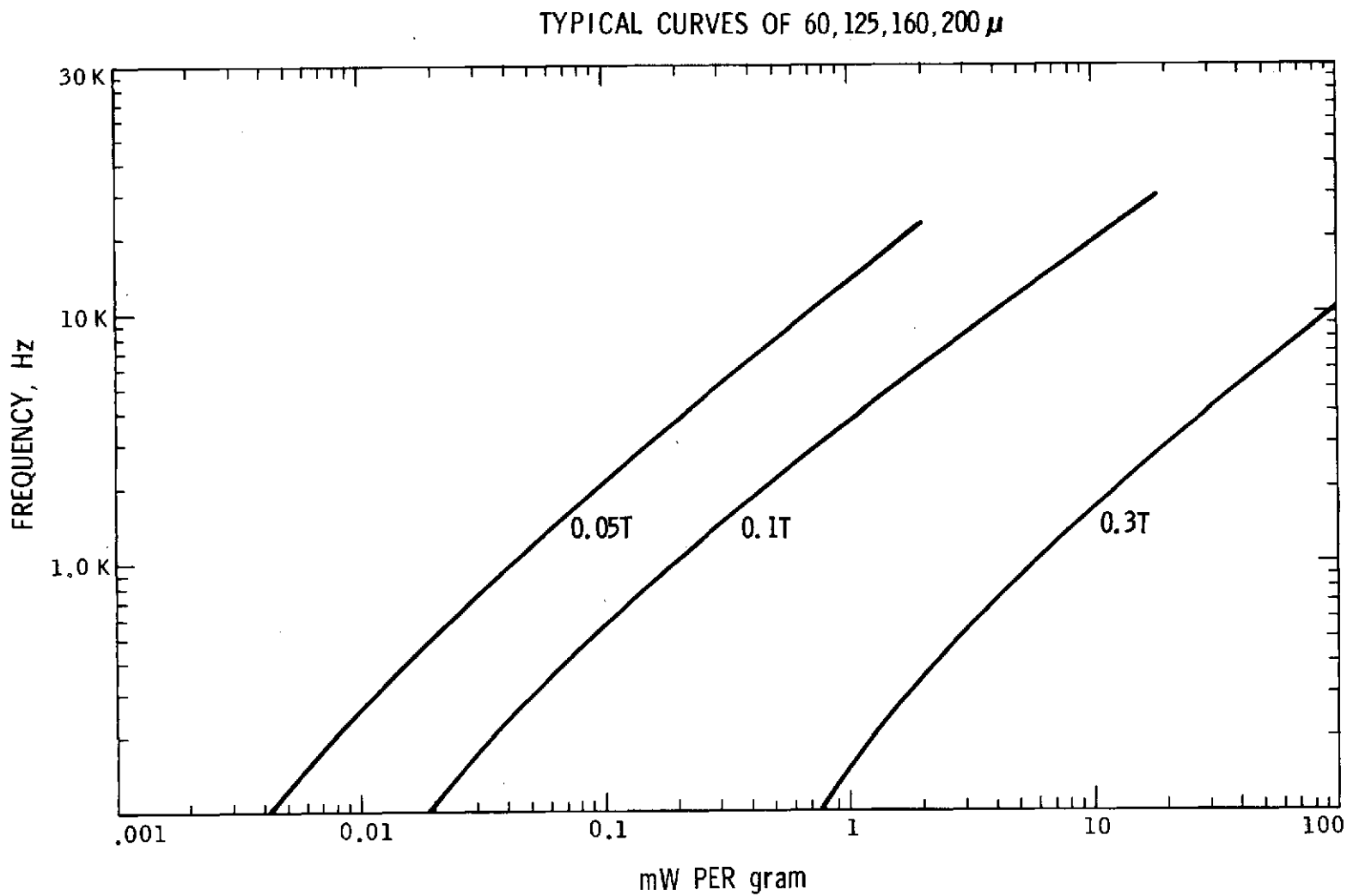

Fig. 23. Core Loss Versus Frequency at 0.05T, 0.1T, and 0.5T

X. POWDER CORE (PERMEABILITY VERSUS dc BIAS)

Figure 24 shows inductance change versus dc bias for 60, 125 and 200 permeability materials.

In designing for operation at high dc currents, it is desirable to choose a core permeability which will result in maximum inductance at peak current.

$$H = \frac{NI}{lm}$$

H = magnetizing force ampturns/cm

N = number of turns

I = peak currents (Amperes)

lm = mean magnetic path (cm)

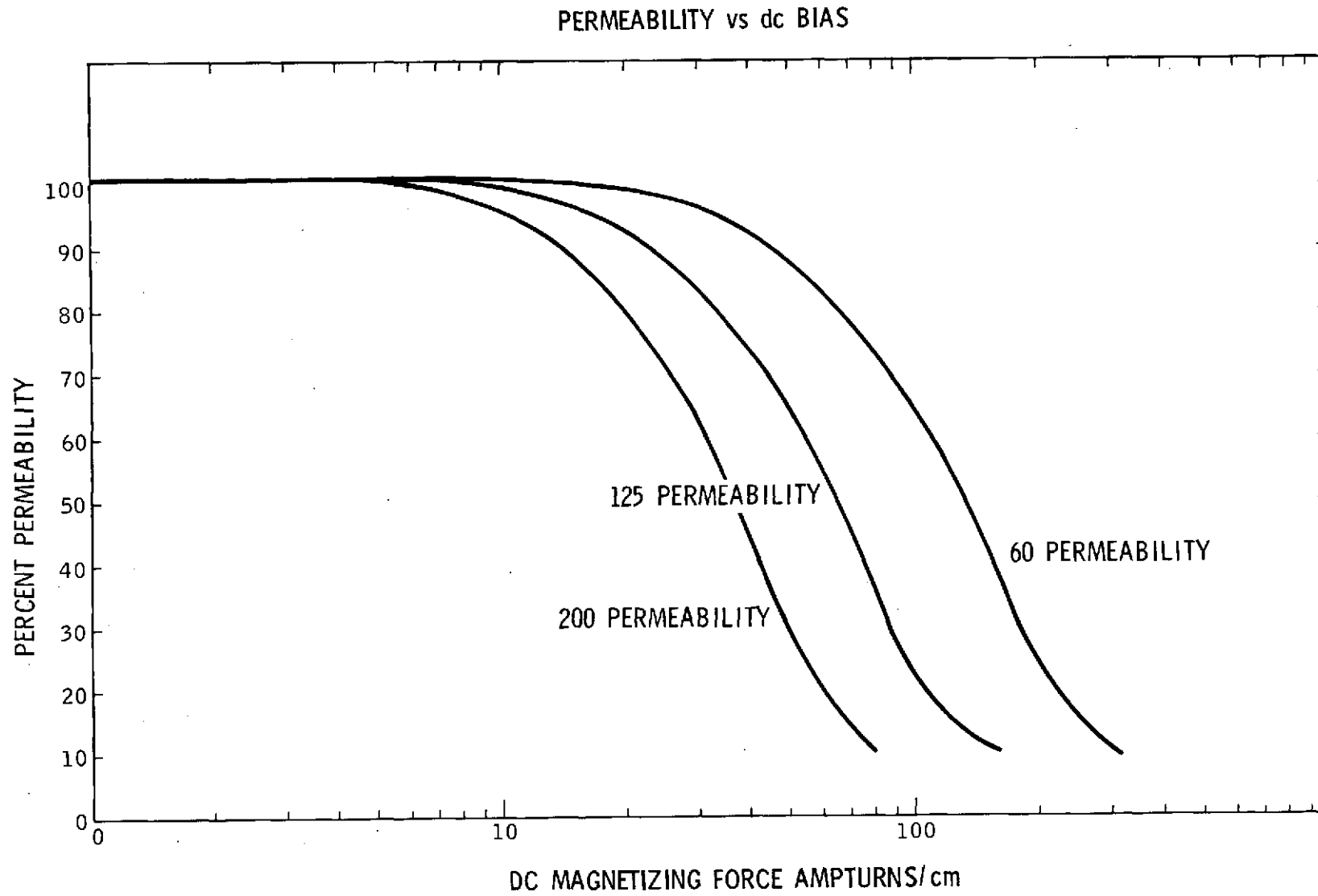

Fig. 24. Permeability vs dc Bias

XI. LAMINATION, C CORE AND BOBBIN MAGNETIC AND DIMENSIONAL SPECIFICATIONS

A. Definitions for Tables 16 through 41.

Tables 16 through 41 show magnetic and dimensional specifications for eleven EE, EI laminations and C cores. Information given is listed by line as:

- 1 Manufacturer and part number
- 2 Units
- 3 Window area W_a divided by iron area A_c
- 4 Iron area A_c times the window area W_a
- 5 Iron area A_c
- 6 Window area W_a
- 7 Mean magnetic path length l_m
- 8 Core weight of silicon steel with unity stacking factor. For the appropriate weight multiply the solid weight by the stacking factor and density factor.

Stacking Factor

Thickness	Butt Jointed	Interleaved 1 x 1
0.004	0.90	0.80
0.006	0.90	0.85
0.014	0.95	0.90
0.018	0.95	0.90

Density Factor

3% Silicon	7.64 gm/cc = 1.00
48% Nickel	8.25 gm/cc = 1.08
80% Nickel	8.74 gm/cc = 1.14

- 9 Weight = copper fully wound
- 10 MLT Fullwound = single winding on bobbin
- 11 MLT 1st half = First of two windings wound with equal area
- 12 MLT 2nd half = Second of two windings wound with equal area
- 13 Transformer overall surface area A_t
- 14-19 Lamination dimensions

- 20 Bobbin Manufacturer and part number
- 21 Bobbin inside winding length
- 22 Bobbin inside build
- 23 Bobbin winding area length x build

B. Nomographs for 11 Laminations and 15 C Core Sizes

Figures 25 through 50 are nomographs for 11 different laminations and 15 C cores sizes. The nomographs display resistance, number of turns,* and wire size at a fill factor of $K_2 = 0.60$. These nomographs are included to provide a close approximation for breadboarding purposes.

*Per bobbin

Table 16. Lamination EE-30-31

	ENGLISH	METRIC
Wa/Ac	3.00	3.00
Wa x Ac	0.000213 in ⁴	0.00964 cm ⁴
Ac	0.00879 in ²	0.0567 cm ²
Wa	0.0264 in ²	0.1701 cm ²
lm	0.938 in	2.381 cm
CORE wt SOLID	0.00224 lb	1.02 grams
COPPER wt	0.002 lb	0.88 grams
MLT FULLWOUND	0.677 in	1.72 cm
MLT 1st HALF	0.568 in	1.44 cm
MLT 2nd HALF	0.785 in	1.99 cm
A _T	0.6374 in ²	4.11 cm ²
A	0.094 in	0.239 cm
B	0.047 in	0.119 cm
C	0.094 in	0.239 cm
D	0.281 in	0.714 cm
E	0.375 in	0.953 cm
F	0.375 in	0.953 cm
BOBBIN	NY-GLASS #NY-1	
LENGTH	0.230 in	0.584 cm
BUILD	0.069 in	0.175 cm
AREA	0.0159 in ²	0.102 cm ²

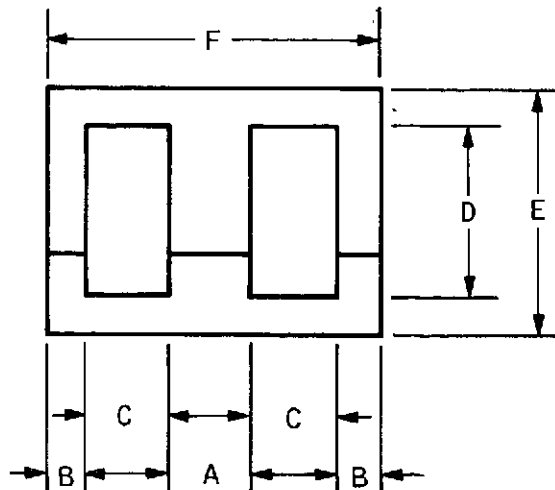

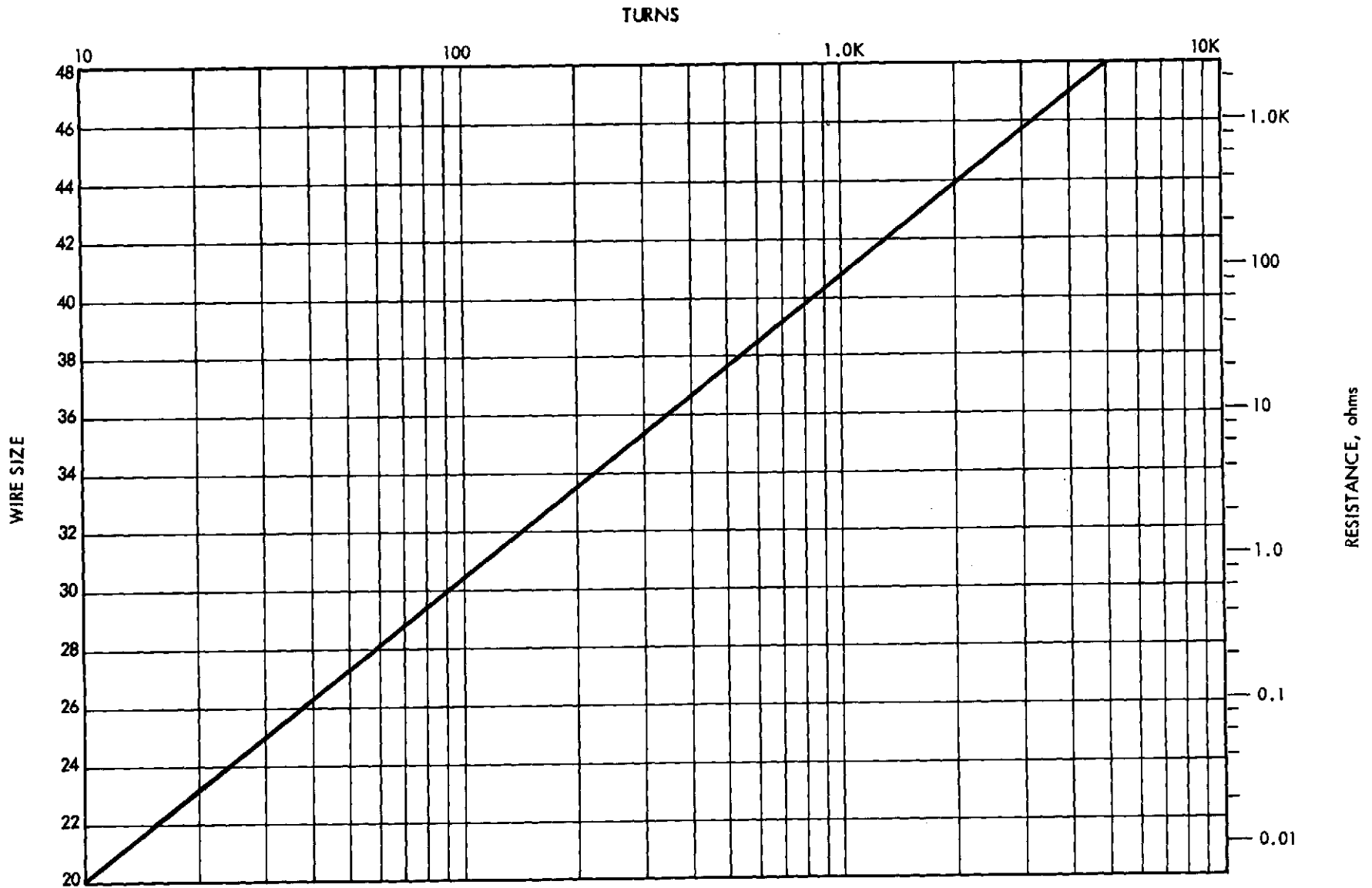
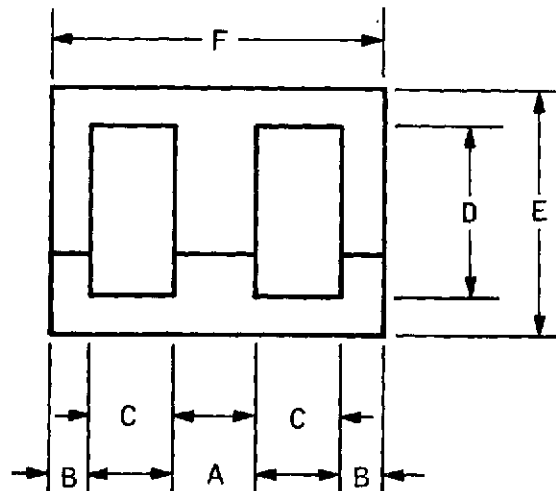

Fig. 25. Nomograph for Lamination EE-30-31

Table 17. Lamination EE-28-29

	ENGLISH	METRIC
Wa/Ac	2.52	2.52
Wa x Ac	0.00061 in ⁴	0.0258 cm ⁴
Ac	0.0156 in ²	0.101 cm ²
Wa	0.0391 in ²	0.256 cm ²
lm	1.125 in	2.858 cm
CORE wt SOLID	0.00482 lb	2.19 grams
COPPER wt	0.004 lb	1.85 grams
MLT FULLWOUND	0.892 in	2.265 cm
MLT 1st HALF	0.740 in	1.879 cm
MLT 2nd HALF	1.045 in	2.654 cm
A _T	1.027 in ²	6.625 cm ²
A	0.125 in	0.318 cm
B	0.062 in	0.157 cm
C	0.125 in	0.318 cm
D	0.312 in	0.792 cm
E	0.438 in	1.113 cm
F	0.500 in	1.270 cm
BOBBIN	NY-GLASS #NY-2	
LENGTH	0.269 in	0.673 cm
BUILD	0.097 in	0.246 cm
AREA	0.026 in ²	0.168 cm ²



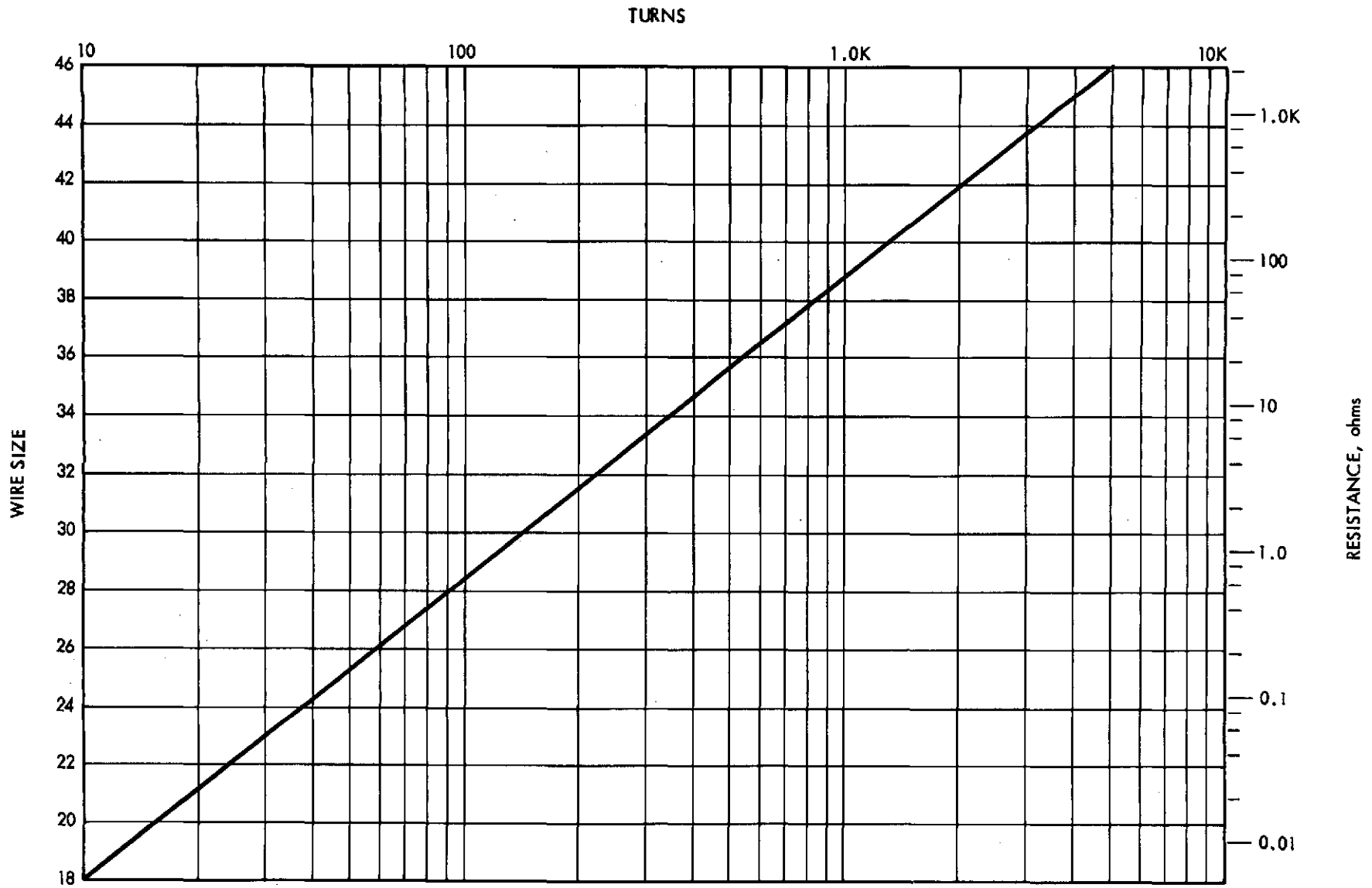
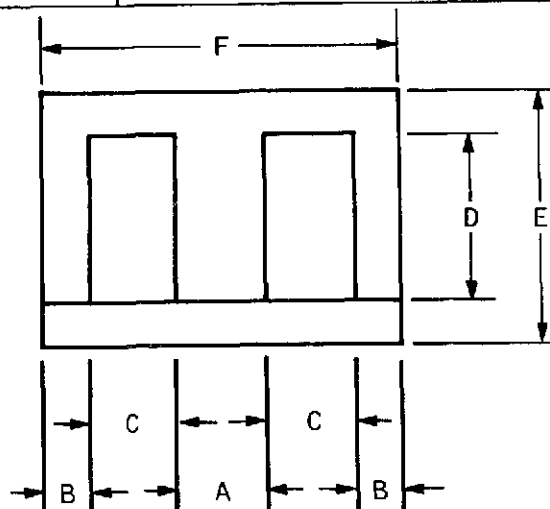

Fig. 26. Nomograph for Lamination EE-28-29

Table 18. Lamination EI-187

	ENGLISH	METRIC
Wa/Ac	2.33	2.33
Wa x Ac	0.00288 in ⁴	0.120 cm ⁴
Ac	0.0352 in ²	0.227 cm ²
Wa	0.0820 in ²	0.529 cm ²
lm	1.625 in	4.128 cm
CORE wt SOLID	0.156 lb	7.09 grams
COPPER wt	0.0136 lb	6.20 grams
MLT FULLWOUND	1.34 in	3.40 cm
MLT 1st HALF	1.11 in	2.82 cm
MLT 2nd HALF	1.57 in	3.99 cm
A _T	2.270 in ²	14.65 cm ²
A	0.188 in	0.478 cm
B	0.094 in	0.239 cm
C	0.188 in	0.478 cm
D	0.438 in	1.113 cm
E	0.625 in	1.588 cm
F	0.750 in	1.905 cm
BOBBIN	NY-GLASS # NY-4	
LENGTH	0.375 in	0.953 cm
BUILD	0.147 in	0.373 cm
AREA	0.0551 in ²	0.355 cm ²



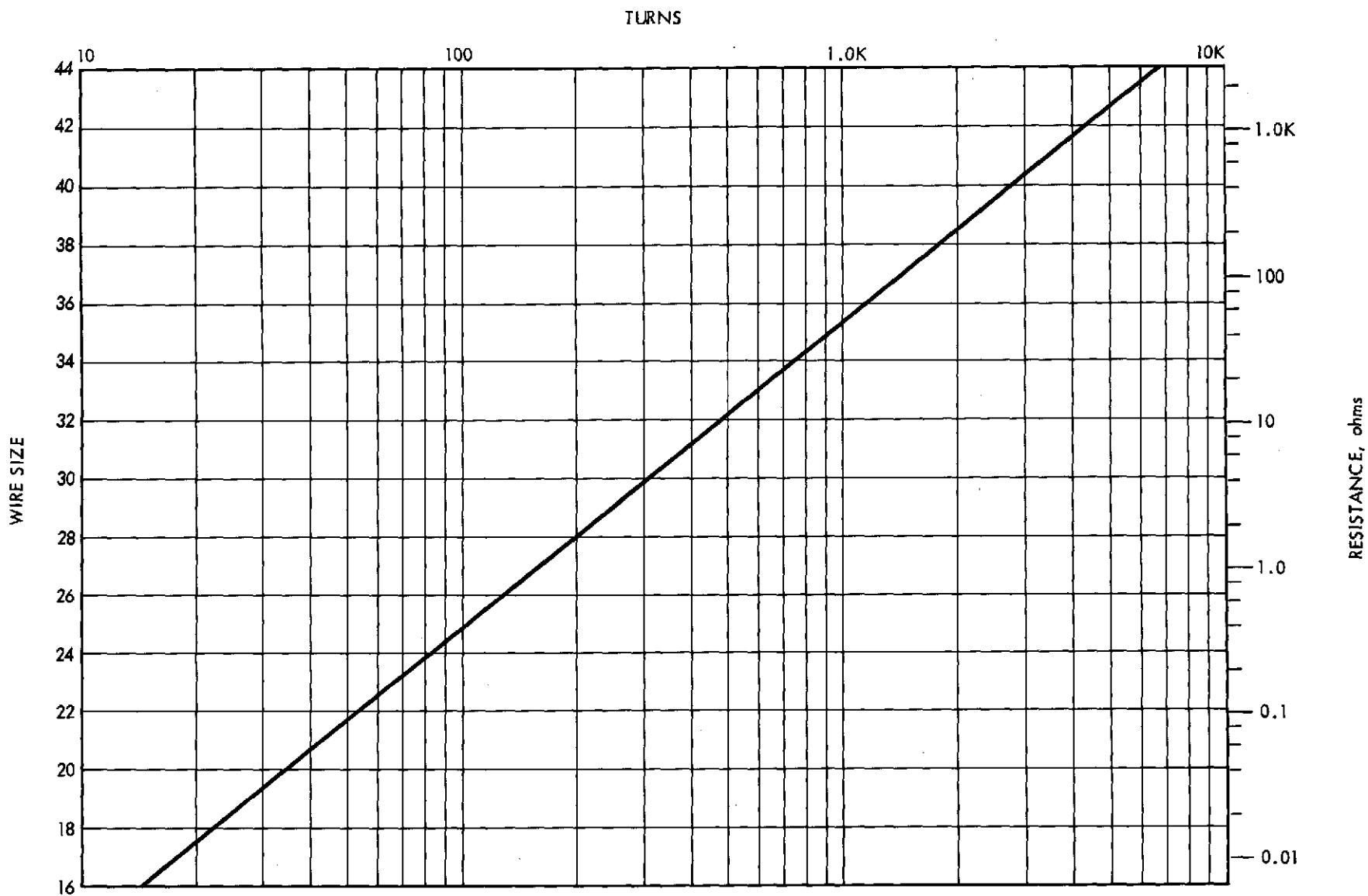
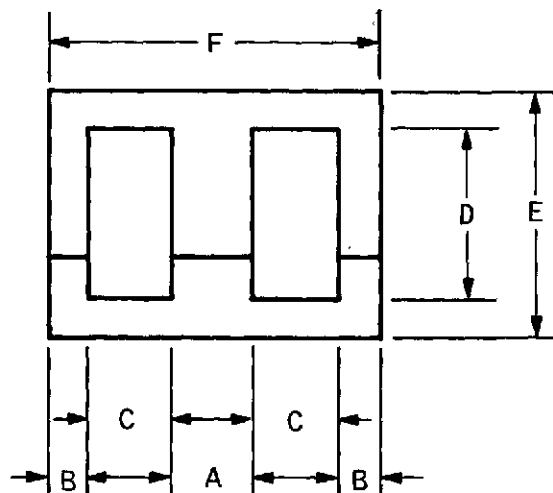

Fig. 27. Nomograph for Lamination E1-187

Table 19. Lamination EE-24-25

	ENGLISH	METRIC
Wa/Ac	2.00	2.00
Wa x Ac	0.00781 in ⁴	0.325 cm ⁴
Ac	0.0625 in ²	0.403 cm ²
Wa	0.125 in ²	0.806 cm ²
lm	2.00 in	5.08 cm
CORE wt SOLID	0.0342 lb	15.50 grams
COPPER wt	0.0254 lb	11.5 grams
MLT FULLWOUND	1.800 in	4.57 cm
MLT 1st HALF	1.470 in	3.73 cm
MLT 2nd HALF	2.130 in	5.41 cm
A _T	3.30 in ²	21.3 cm ²
A	0.25 in	0.635 cm
B	0.125 in	0.318 cm
C	0.250 in	0.635 cm
D	0.500 in	0.127 cm
E	0.750 in	1.905 cm
F	1.000 in	2.540 cm
BOBBIN	NY-GLASS # NY-6	
LENGTH	0.415 in	1.054 cm
BUILD	0.210 in	0.533 cm
AREA	0.0872 in ²	0.5624 cm ²



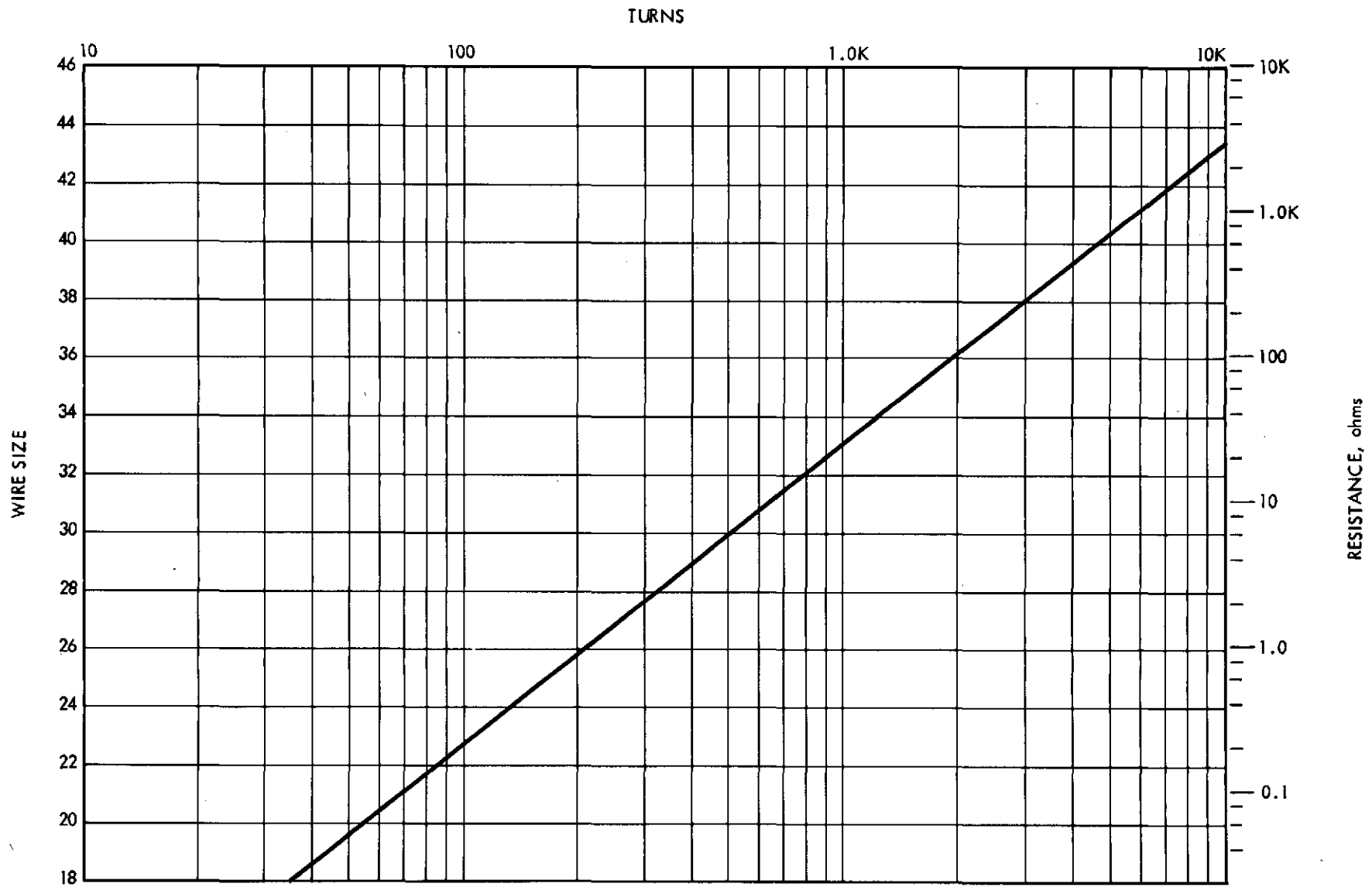
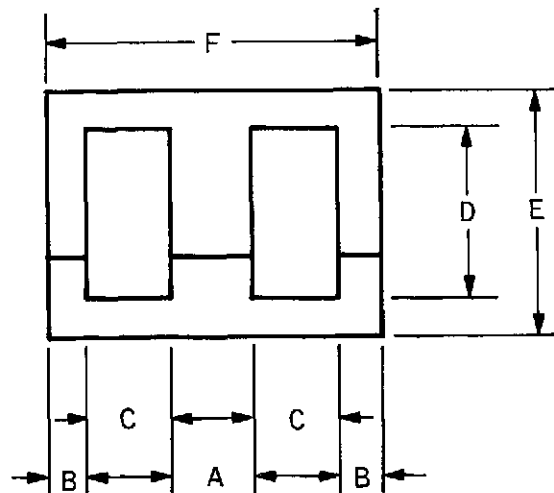

Fig. 28. Nomograph for Lamination EE-24-25

Table 20. Lamination EE-26-27

	ENGLISH	METRIC
Wa/Ac	1.22	1.22
Wa x Ac	0.0242 in ⁴	1.005 cm ⁴
Ac	0.141 in ²	0.907 cm ²
Wa	0.172 in ²	1.109 cm ²
lm	2.63 in	6.66 cm
CORE wt SOLID	0.101 lb	45.8 grams
COPPER wt	0.0507 lb	23 grams
MLT FULLWOUND	2.32 in	5.89 cm
MLT 1st HALF	1.99 in	5.05 cm
MLT 2nd HALF	2.65 in	6.73 cm
A _T	6.295 in ²	40.6 cm ²
A	0.375 in	0.953 cm
B	0.188 in	0.478 cm
C	0.250 in	0.635 cm
D	0.688 in	1.748 cm
E	1.062 in	2.697 cm
F	1.250 in	3.18 cm
BOBBIN	NY-GLASS # NY-8	
LENGTH	0.605 in	1.537 cm
BUILD	0.210 in	0.533 cm
AREA	0.127 in ²	0.819 cm ²



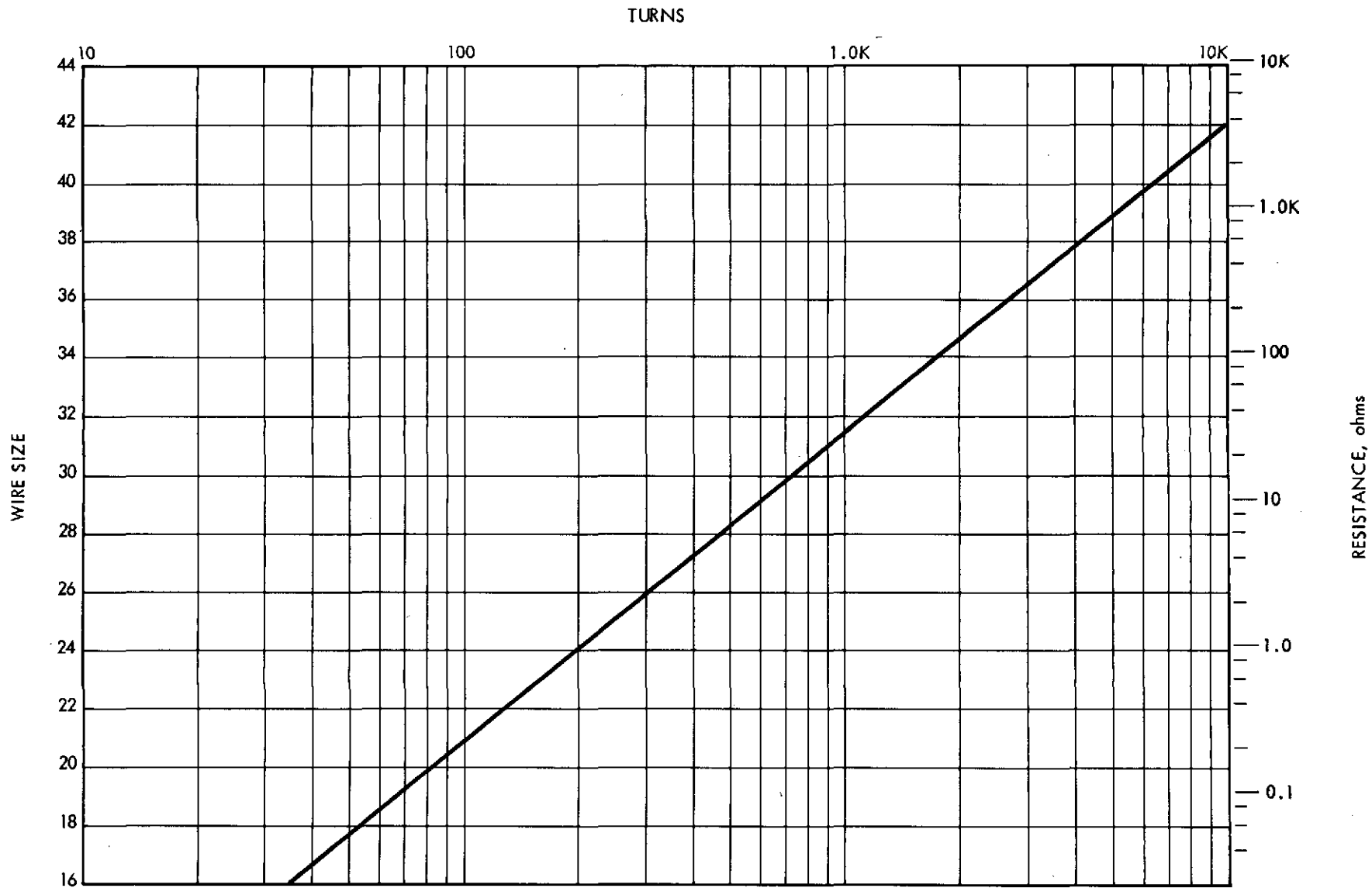
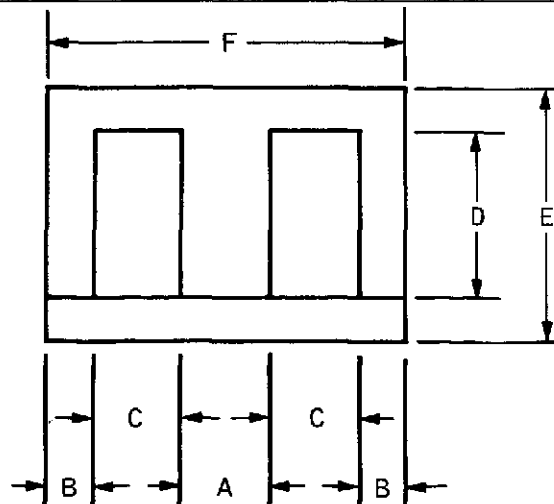

Fig. 29. Nomograph for Lamination EE-26-27

Table 21. Lamination EI-375

	ENGLISH	METRIC
Wa/Ac	1.66	1.66
Wa x Ac	0.0327 in ⁴	1.374 cm ⁴
Ac	0.14 in ²	0.91 cm ²
Wa	0.234 in ²	1.51 cm ²
lm	2.88 in	7.30 cm
CORE wt SOLID	0.110 lb	49.7 grams
COPPER wt	0.0772 lb	35.0 grams
MLT FULLWOUND	2.515 in	6.39 cm
MLT 1st HALF	2.087 in	5.30 cm
MLT 2nd HALF	2.94 in	7.47 cm
A _T	7.390 in ²	47.68 cm ²
A	0.375 in	0.953 cm
B	0.188 in	0.478 cm
C	0.312 in	0.792 cm
D	0.750 in	1.905 cm
E	1.125 in	2.858 cm
F	1.375 in	3.493 cm
BOBBIN	NY-GLASS # NY-7	
LENGTH	0.665 in	1.689 cm
BUILD	0.272 in	0.691 cm
AREA	0.181 in ²	1.1674 cm ²



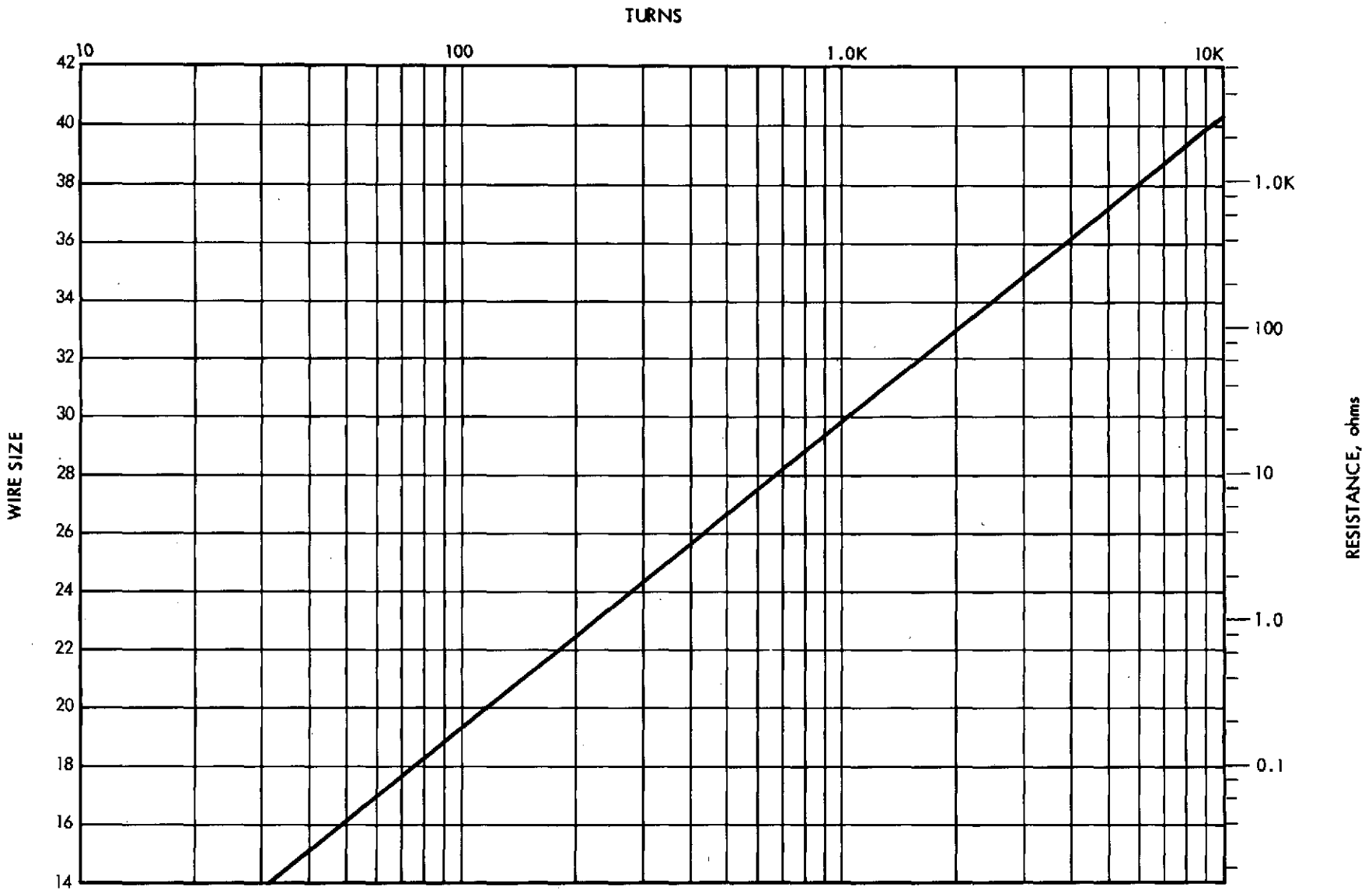
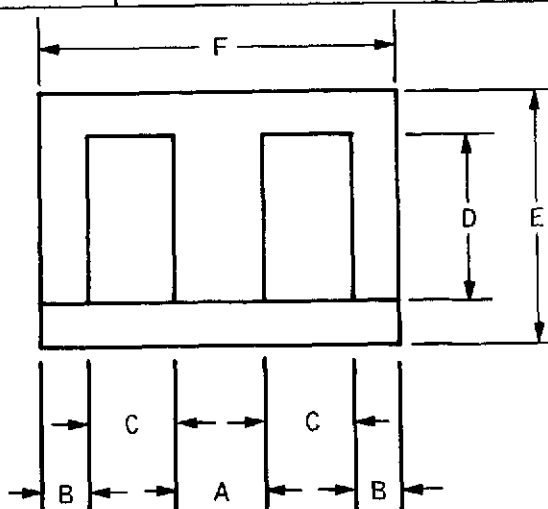

Fig. 30. Nomograph for Lamination EI-375

Table 22. Lamination EI-50

	ENGLISH	METRIC																					
Wa/Ac	0.750	0.750																					
Wa x Ac	0.047 in ⁴	1.95 cm ⁴																					
Ac	0.250 in ²	1.61 cm ²																					
Wa	0.188 in ²	1.21 cm ²																					
Im	3.00 in	7.62 cm																					
CORE wt SOLID	0.203 lb	92.0 grams																					
COPPER wt	0.0617 lb	28.0 grams																					
MLT FULLWOUND	2.82 in	7.15 cm																					
MLT 1st HALF	2.50 in	6.36 cm																					
MLT 2nd HALF	3.13 in	7.95 cm																					
A _T	8.93 in ²	57.6 cm ²																					
A	0.500 in	1.27 cm																					
B	0.250 in	0.635 cm																					
C	0.250 in	0.635 cm	D	0.750 in	1.91 cm	E	1.25 in	3.18 cm	F	1.50 in	3.81 cm	BOBBIN	NY-GLASS # NY-44		LENGTH	0.661 in	1.68 cm	BUILD	0.200 in	0.508 cm	AREA	0.132 in ²	0.852 cm ²
D	0.750 in	1.91 cm																					
E	1.25 in	3.18 cm																					
F	1.50 in	3.81 cm																					
BOBBIN	NY-GLASS # NY-44																						
LENGTH	0.661 in	1.68 cm																					
BUILD	0.200 in	0.508 cm																					
AREA	0.132 in ²	0.852 cm ²																					



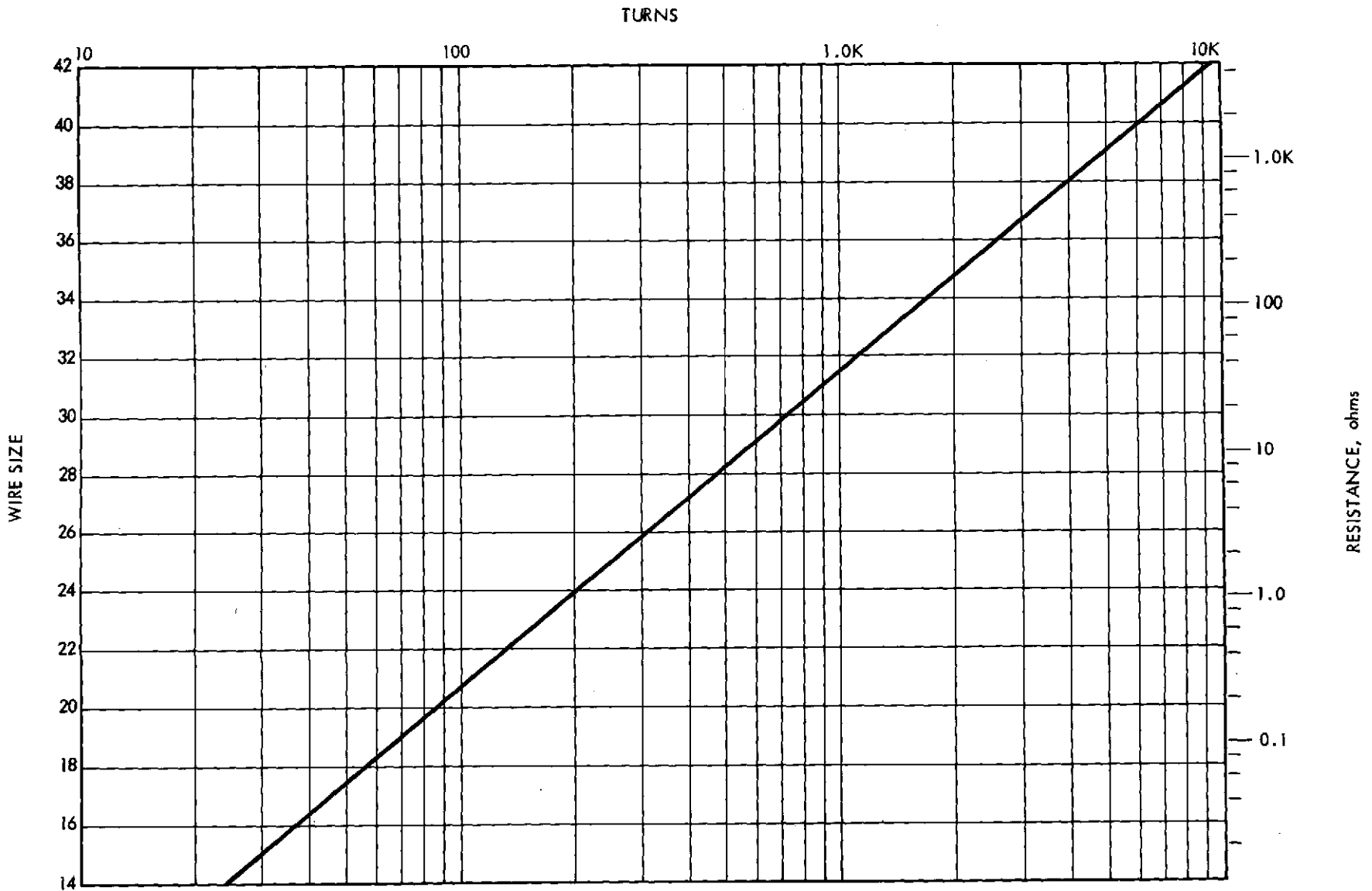
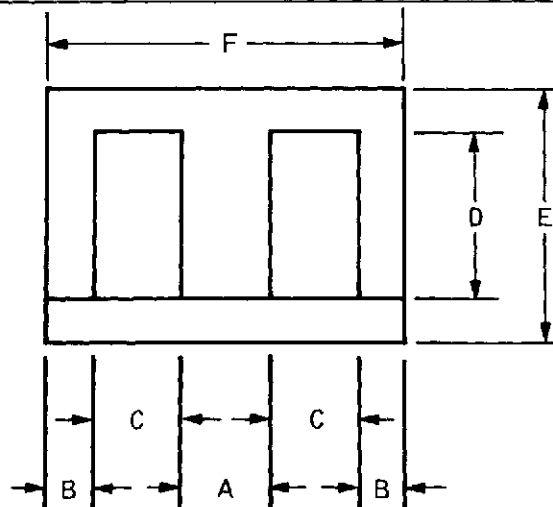

Fig. 31. Nomograph for Lamination EI-50

Table 23. Lamination EI-21

	ENGLISH	METRIC
Wa/Ac	1.02	1.02
Wa x Ac	0.0635 in ⁴	2.64 cm ⁴
Ac	0.25 in ²	1.61 cm ²
Wa	0.254 in ²	1.64 cm ²
Im	3.25 in	8.255 cm
CORE wt SOLID	0.219 lb	99.3 grams
COPPER wt	0.090 lb	41 grams
MLT FULLWOUND	3.01 in	7.92 cm
MLT 1st HALF	2.60 in	6.59 cm
MLT 2nd HALF	3.43 in	8.71 cm
A _T	10.2 in ²	66.0 cm ²
A	0.500 in	1.27 cm
B	0.250 in	0.635 cm
C	0.312 in	0.792 cm
D	0.812 in	2.06 cm
E	1.31 in	3.33 cm
F	1.63 in	4.13 cm
BOBBIN	NY-GLASS # NY-9	
LENGTH	0.726 in	1.84 cm
BUILD	0.265 in	0.673 cm
AREA	0.192 in ²	1.240 cm ²



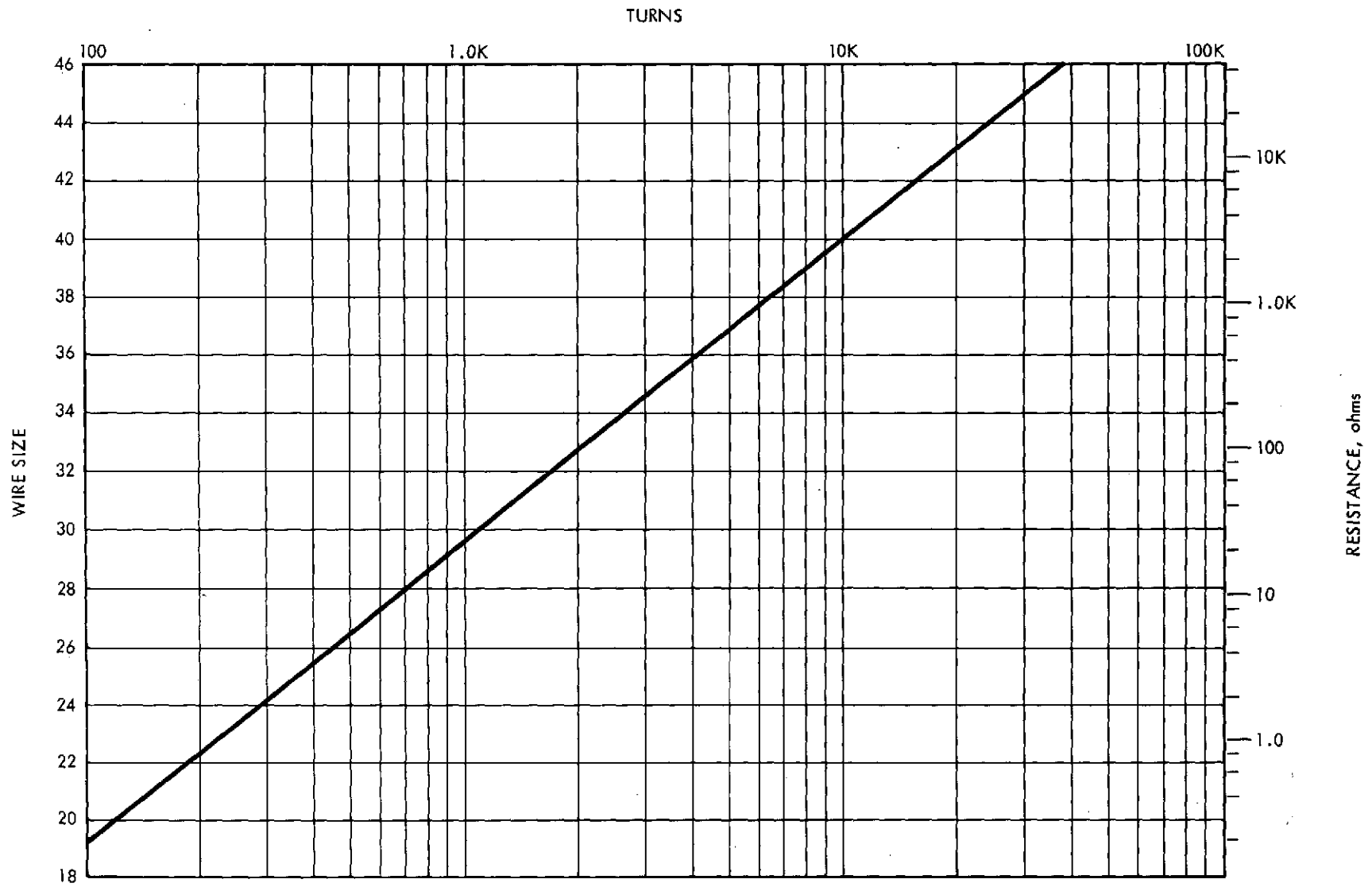
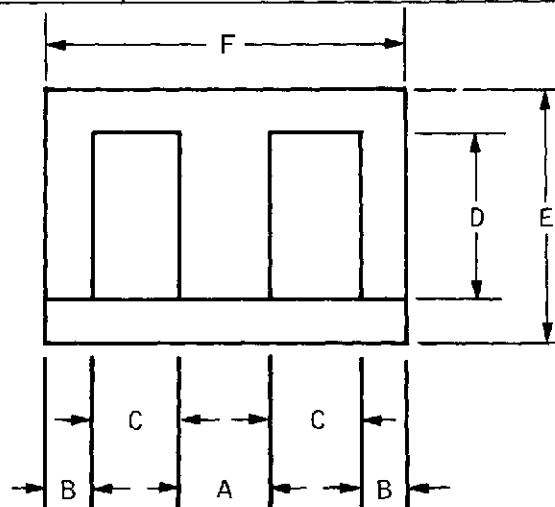

Fig. 32. Nomograph for Lamination EI-21

Table 24. Lamination EI-625

	ENGLISH	METRIC
Wa/Ac	0.750	0.750
Wa x Ac	0.115 in ⁴	4.76 cm ⁴
Ac	0.391 in ²	2.52 cm ²
Wa	0.293 in ²	1.89 cm ²
lm	3.75 in	9.53 cm
CORE wt SOLID	0.395 lb	179 grams
COPPER wt	0.154 lb	70 grams
MLT FULLWOUND	3.39 in	8.60 cm
MLT 1st HALF	3.04 in	7.29 cm
MLT 2nd HALF	3.73 in	9.48 cm
A _T	13.9 in ²	89.6 cm ²
A	0.625 in	1.59 cm
B	0.312 in	0.792 cm
C	0.312 in	0.792 cm
D	0.938 in	2.38 cm
E	1.56 in	3.97 cm
F	1.88 in	4.76 cm
BOBBIN	NY-GLASS # NY-10	
LENGTH	0.841 in	2.14 cm
BUILD	0.260 in	0.660 cm
AREA	0.218 in ²	1.41 cm ²



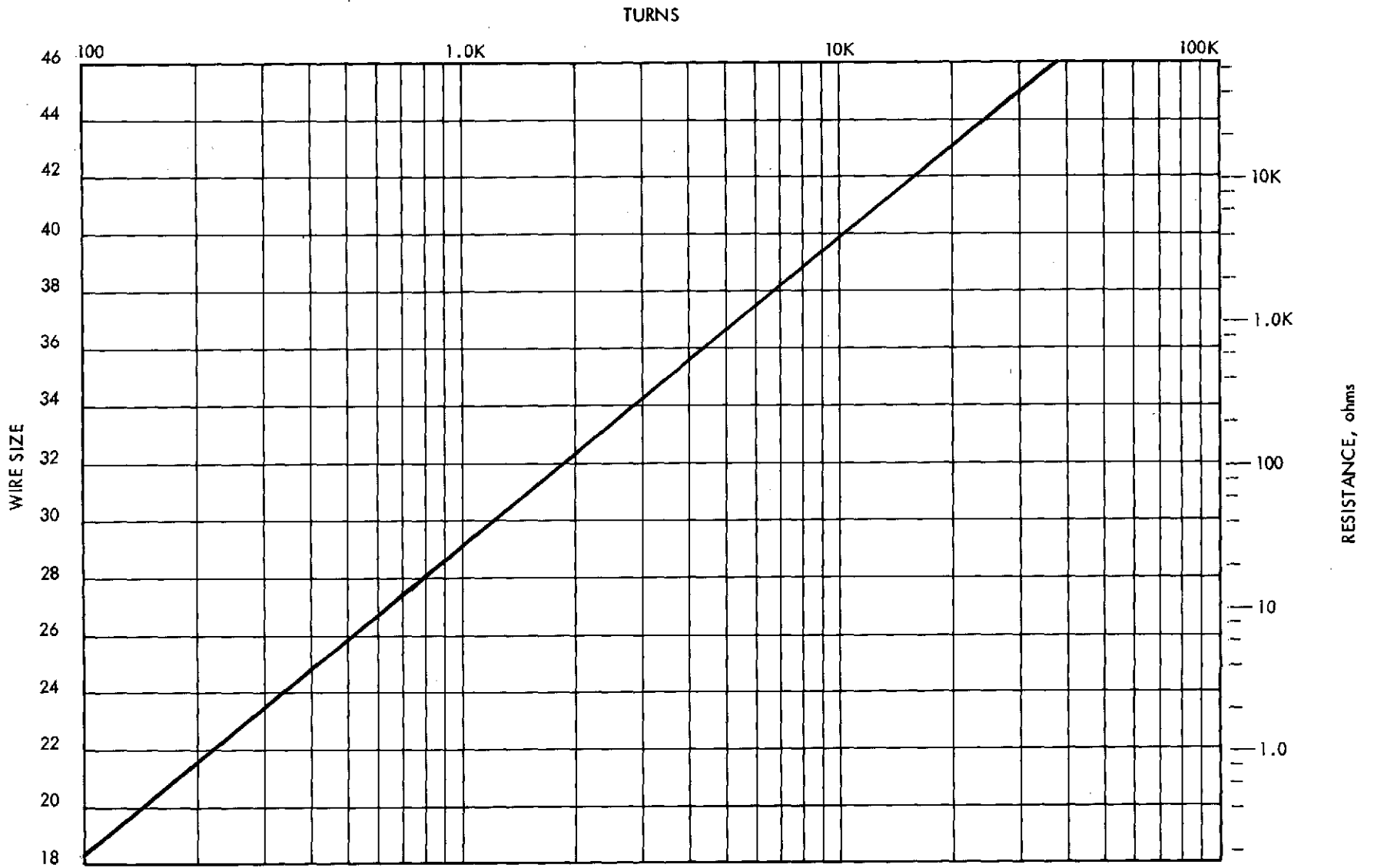
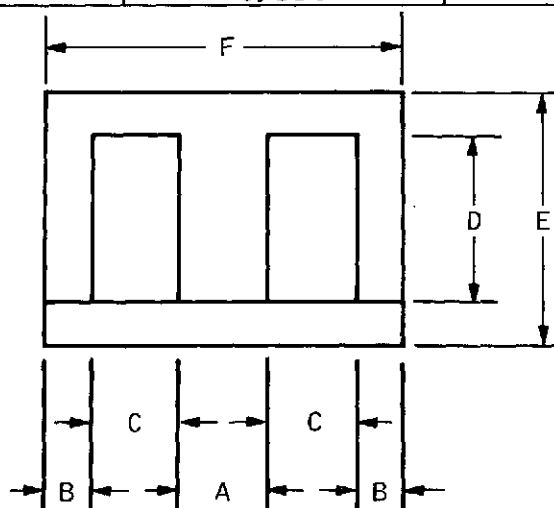

Fig. 33. Nomograph for Lamination EI-625

Table 25. Lamination EI-75

	ENGLISH	METRIC
Wa/Ac	0.750	0.750
Wa x Ac	0.237 in ⁴	9.87 cm ⁴
Ac	0.563 in ²	3.63 cm ²
Wa	0.422 in ²	2.72 cm ²
l _m	4.50 in	11.4 cm
CORE wt SOLID	0.688 lb	312 grams
COPPER wt	0.232 lb	105 grams
MLT FULLWOUND	4.21 in	10.7 cm
MLT 1st HALF	3.71 in	9.41 cm
MLT 2nd HALF	4.72 in	12.0 cm
A _T	20.1 in ²	130 cm ²
A	0.750 in	1.91 cm
B	0.375 in	0.952 cm
C	0.375 in	0.952 cm
D	1.125 in	2.86 cm
E	1.875 in	4.76 cm
F	2.25 in	5.72 cm
BOBBIN	NY-GLASS # NY-11	
LENGTH	1.02 in	2.59 cm
BUILD	0.322 in	0.838 cm
AREA	0.330 in ²	2.13 cm ²



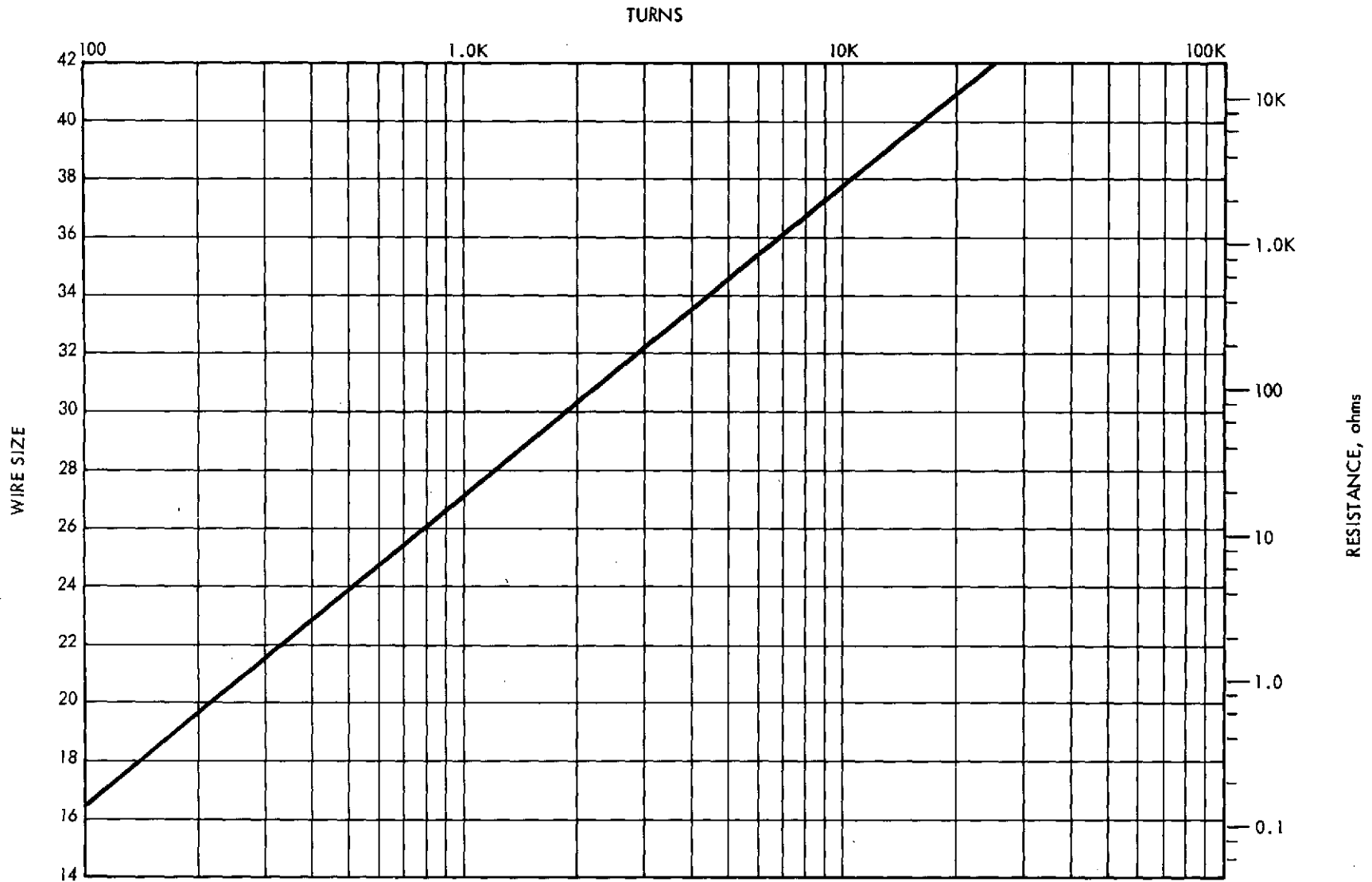
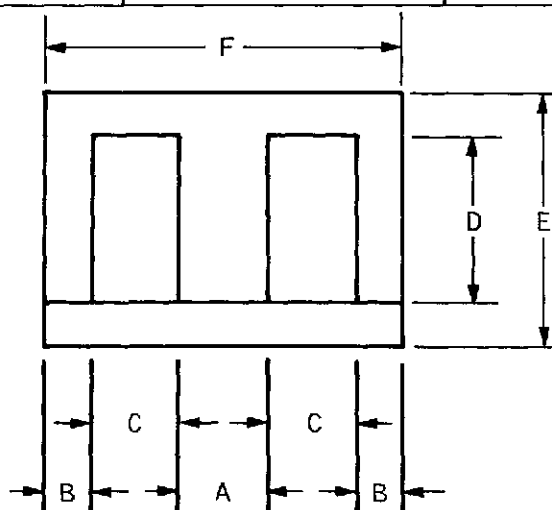

Fig. 34. Nomograph for Lamination EI-75

Table 26. Lamination EI-87

	ENGLISH	METRIC
Wa/Ac	0.750	0.750
Wa x Ac	0.439 in ⁴	18.3 cm ⁴
Ac	0.766 in ²	4.94 cm ²
Wa	0.574 in ²	3.71 cm ²
Im	5.25 in	13.3 cm
CORE wt SOLID	1.06 lb	481 grams
COPPER wt	0.375 lb	170 grams
MLT FULLWOUND	4.92 in	12.5 cm
MLT 1st HALF	4.32 in	11.0 cm
MLT 2nd HALF	5.52 in	14.0 cm
A _T	27.3 in ²	176 cm ²
A	0.875 in	2.22 cm
B	0.438 in	1.112 cm
C	0.438 in	1.112 cm
D	1.312 in	3.332 cm
E	2.188 in	5.557 cm
F	2.625 in	6.667 cm
BOBBIN	NY-GLASS # NY-12	
LENGTH	1.21 in	3.073 cm
BUILD	0.383 in	0.973 cm
AREA	0.464 in ²	2.993 cm ²



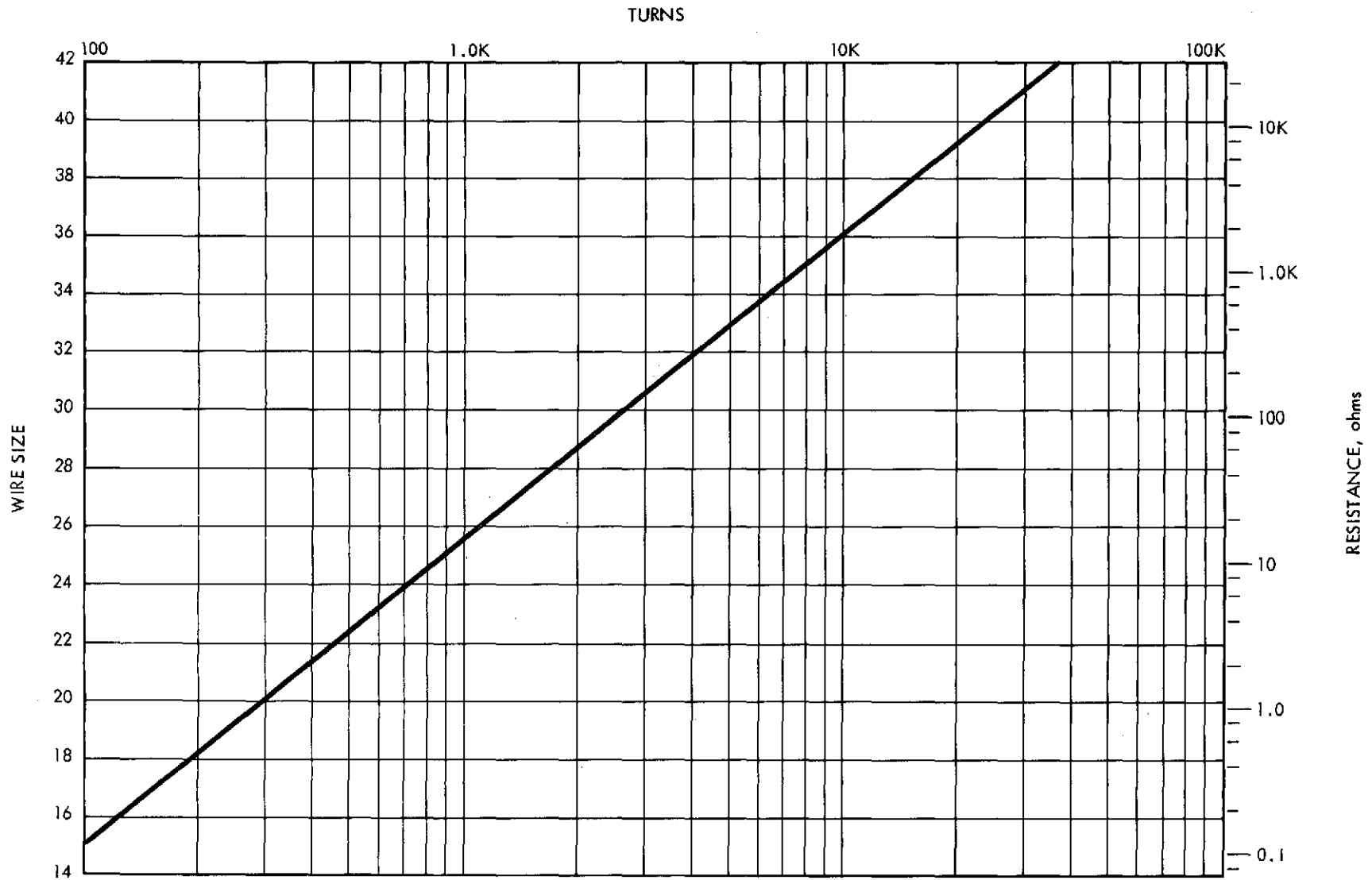
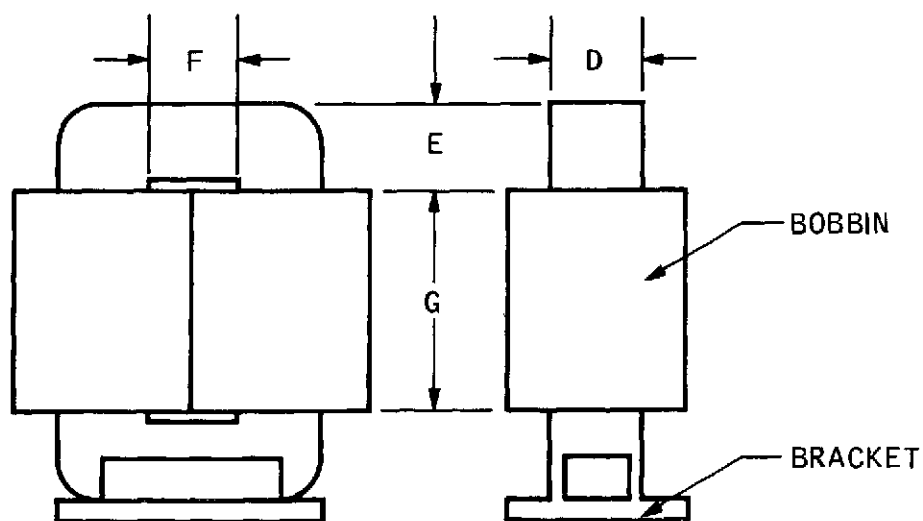

Fig. 35. Nomograph for Lamination EI-87

Table 27. "C" Core Magnetic Inc MC 0001

	ENGLISH	METRIC
Wa/Ac		4.09
Wa x Ac	0.004 in ⁴	0.161 cm ⁴
Ac	0.031 in ²	0.20 cm ²
Wa	0.125 in ²	0.806 cm ²
Im	1.86 in	4.72 cm
CORE wt SOLID	0.016 lb	7.28 grams
COPPER wt	0.015 lb	6.6 grams
MLT FULLWOUND	1.27 in	3.23 cm
MLT 1st HALF	1.11 in	2.82 cm
MLT 2nd HALF	1.43 in	3.63 cm
A _T	2.375 in ²	15.32 cm ²
D	0.25 in	0.635 cm
E	0.125 in	0.317 cm
F	0.25 in	0.635 cm
G	0.50 in	1.270 cm
BOBBIN	DORCO ELECTRONICS # 12767	
LENGTH	0.43 in	1.092 cm
BUILD	0.10 in	0.254 cm
AREA	0.043 in ²	0.277 cm ²
BRACKET	HALLMARK METALS # 04-008-02	



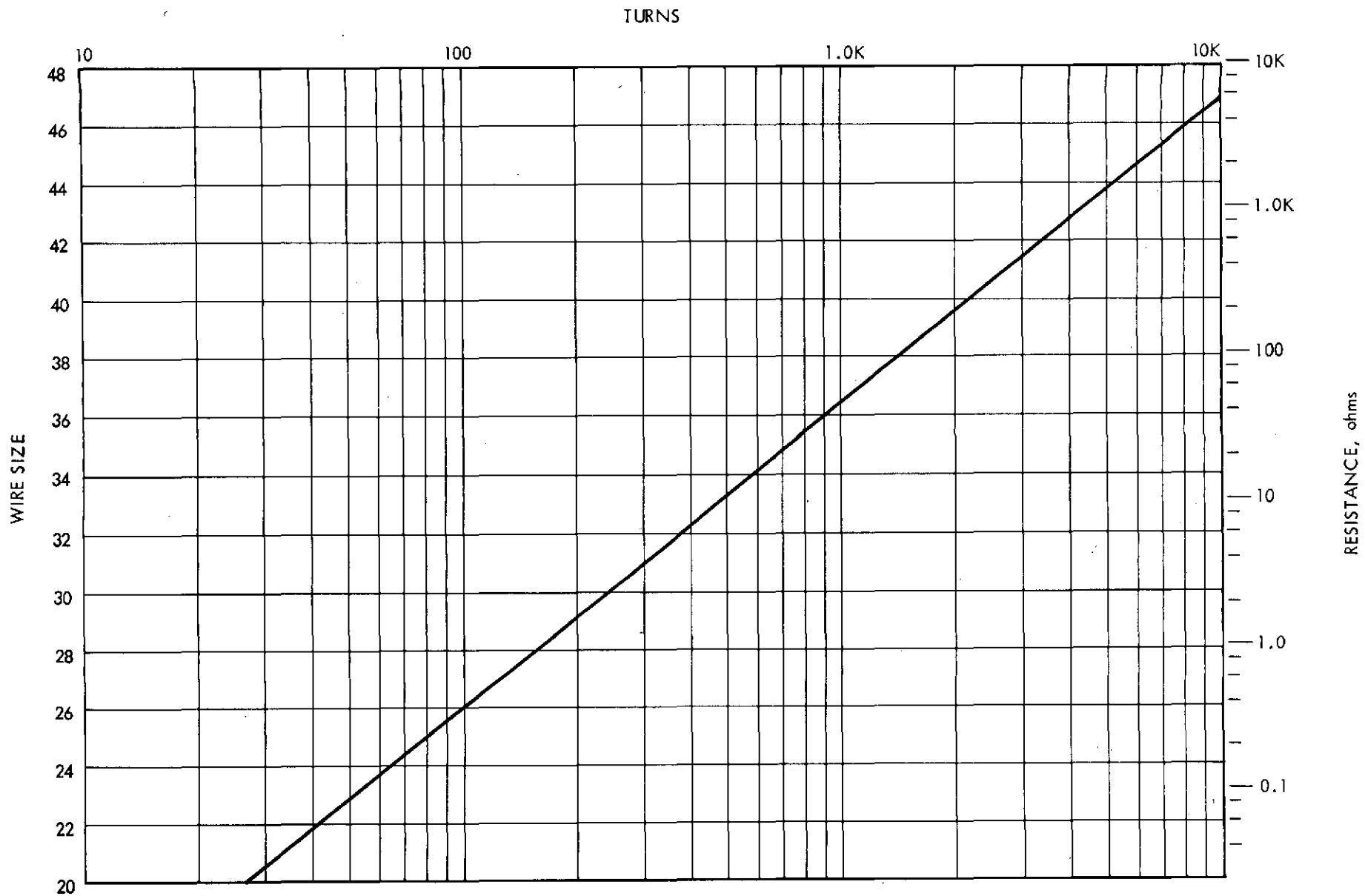
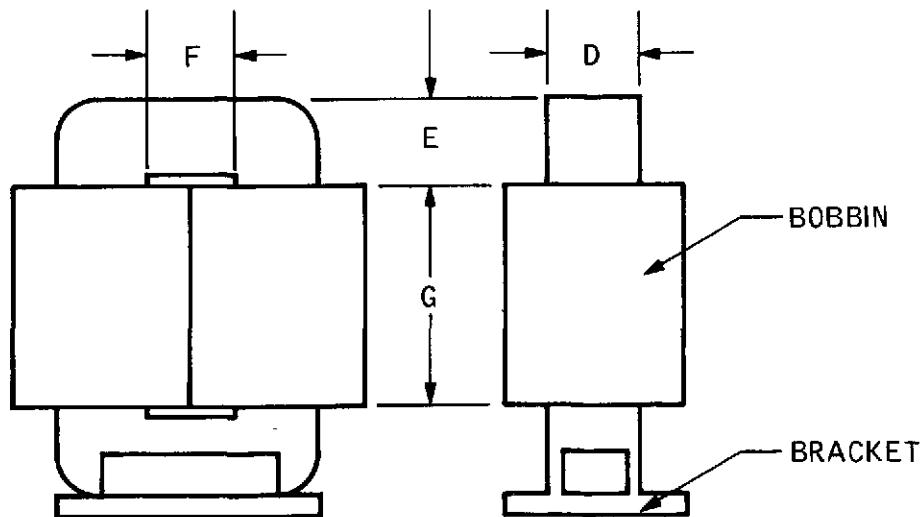

Fig. 36. Nomograph for "C" Core MC 0001

Table 28. "C" Core Magnetic Inc MC 0002

	ENGLISH	METRIC
Wa/Ac		3.66
Wa x Ac	0.00733 in ⁴	0.305 cm ⁴
Ac	0.047 in ²	0.303 cm ²
Wa	0.156 in ²	1.006 cm ²
Im	2.293 in	5.82 cm
CORE wt SOLID	0.0296 lb	13.45 grams
COPPER wt	0.0207 lb	9.4 grams
MLT FULLWOUND	1.39 in	3.53 cm
MLT 1st HALF	1.24 in	3.15 cm
MLT 2nd HALF	1.55 in	3.94 cm
AT	3.25 in ²	20.96 cm ²
D	0.25 in	0.635 cm
E	0.187 in	0.476 cm
F	0.25 in	0.635 cm
G	0.625 in	1.588 cm
BOBBIN	DORCO ELECTRONICS # 12768	
LENGTH	0.560 in	1.42 cm
BUILD	0.100 in	0.254 cm
AREA	0.056 in ²	0.361 cm ²
BRACKET	HALLMARK METALS # 04-010-03	



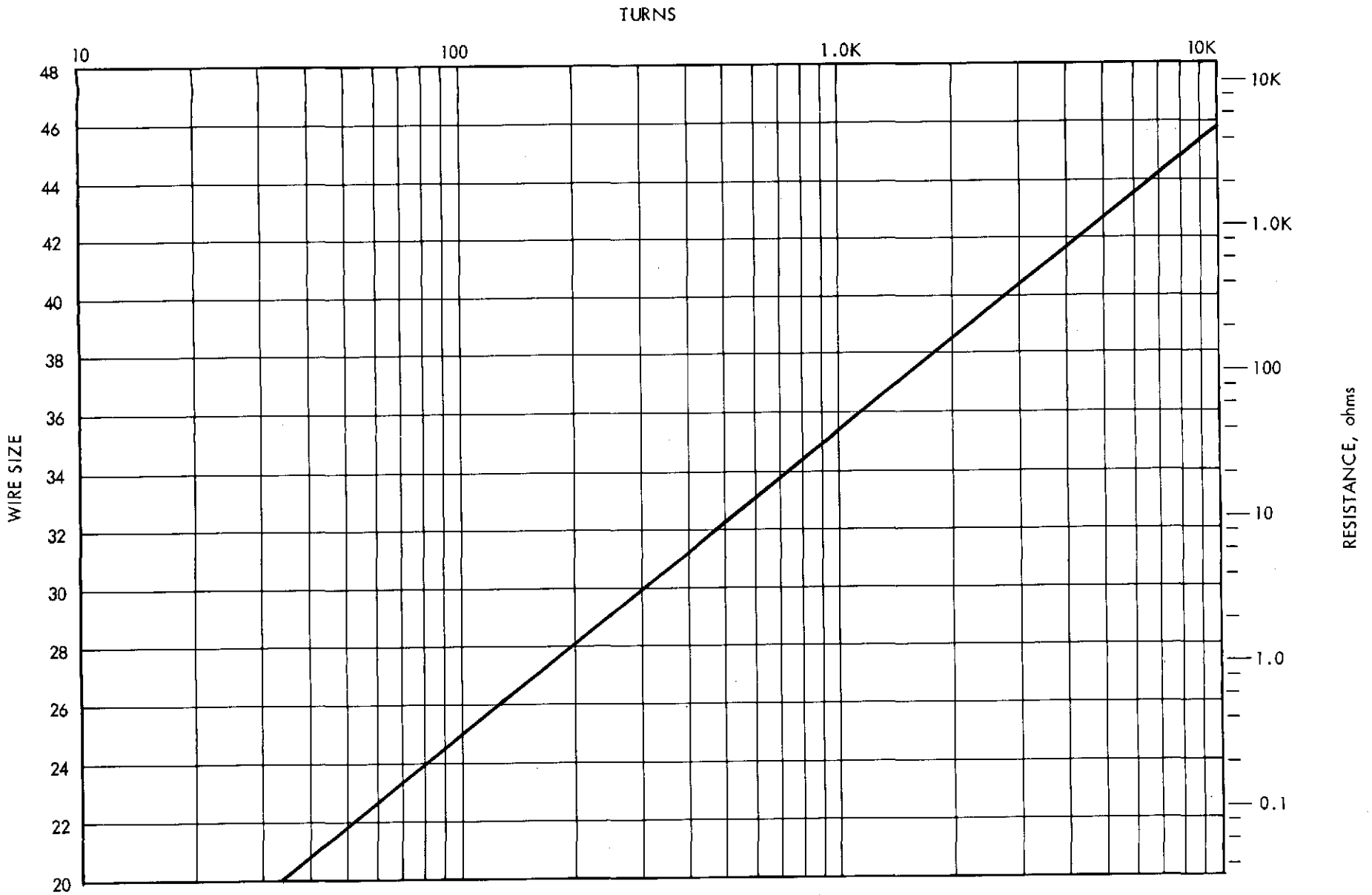
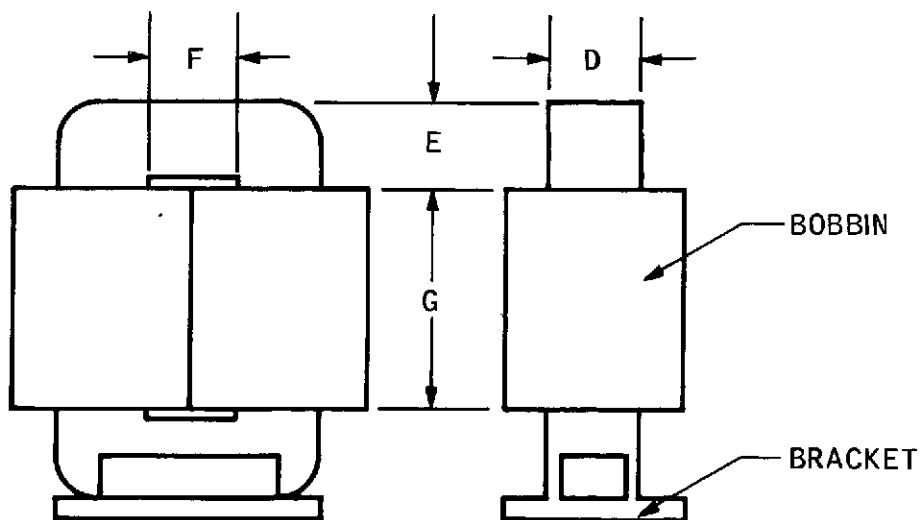

Fig. 37. Nomograph for "C" Core MC 0002

Table 29. "C" Core Magnetic Inc MC 0004

	ENGLISH	METRIC
Wa/Ac		3.58
Wa x Ac	0.014 in ⁴	0.574 cm ⁴
Ac	0.063 in ²	0.406 cm ²
Wa	0.219 in ²	1.413 cm ²
lm	2.975 in	7.55 cm
CORE wt SOLID	0.0513 lb	22.27 grams
COPPER wt	0.0282 lb	12.8 grams
MLT FULLWOUND	1.52 in	3.86 cm
MLT 1st HALF	1.38 in	3.51 cm
MLT 2nd HALF	1.65 in	4.19 cm
AT	4.625 in ²	29.8 cm ²
D	0.25 in	0.635 cm
E	0.25 in	0.635 cm
F	0.25 in	0.635 cm
G	0.875 in	2.222 cm
BOBBIN	DORCO ELECTRONICS # 12769	
LENGTH	0.800 in	2.032 cm
BUILD	0.087 in	0.221 cm
AREA	0.0696 in ²	0.449 cm ²
BRACKET	HALLMARK METALS # 04-012-04	



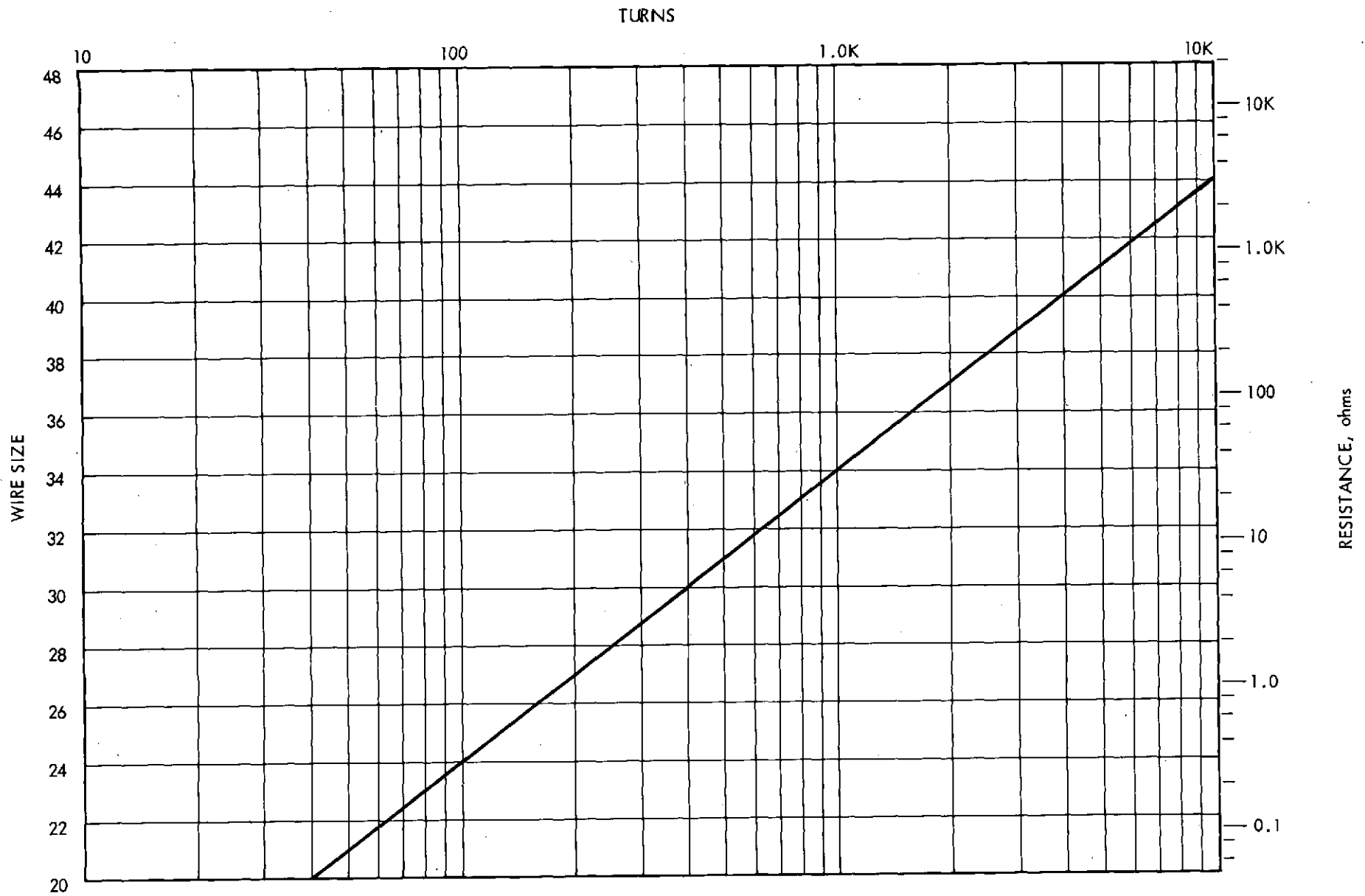
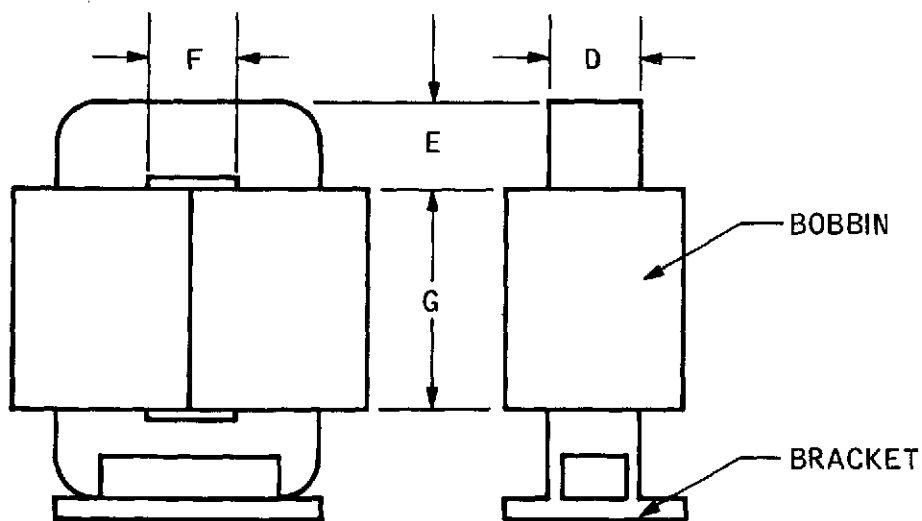

Fig. 38. Nomograph for "C" Core MC 0004

Table 30. "C" Core Magnetic Inc MC 8400

	ENGLISH	METRIC
Wa/Ac		5.37
Wa x Ac	0.021 in ⁴	0.893 cm ⁴
Ac	0.062 in ²	0.403 cm ²
Wa	0.344 in ²	2.217 cm ²
lm	3.98 in	10.09 cm
CORE wt SOLID	0.0686 lb	31.14 grams
COPPER wt	0.057 lb	26 grams
MLT FULLWOUND	1.52 in	3.86 cm
MLT 1st HALF	1.38 in	3.51 cm
MLT 2nd HALF	1.65 in	4.19 cm
AT	6.125 in ²	39.5 cm ²
D	0.25 in	0.635 cm
E	0.25 in	0.635 cm
F	0.25 in	0.635 cm
G	1.375 in	3.493 cm
BOBBIN	DORCO ELECTRONICS # 12770	
LENGTH	1.310 in	3.33 cm
BUILD	0.087 in	0.221 cm
AREA	0.114 in ²	0.735 cm ²
BRACKET	HALLMARK METALS # 04-012-04	



WIRE SIZE

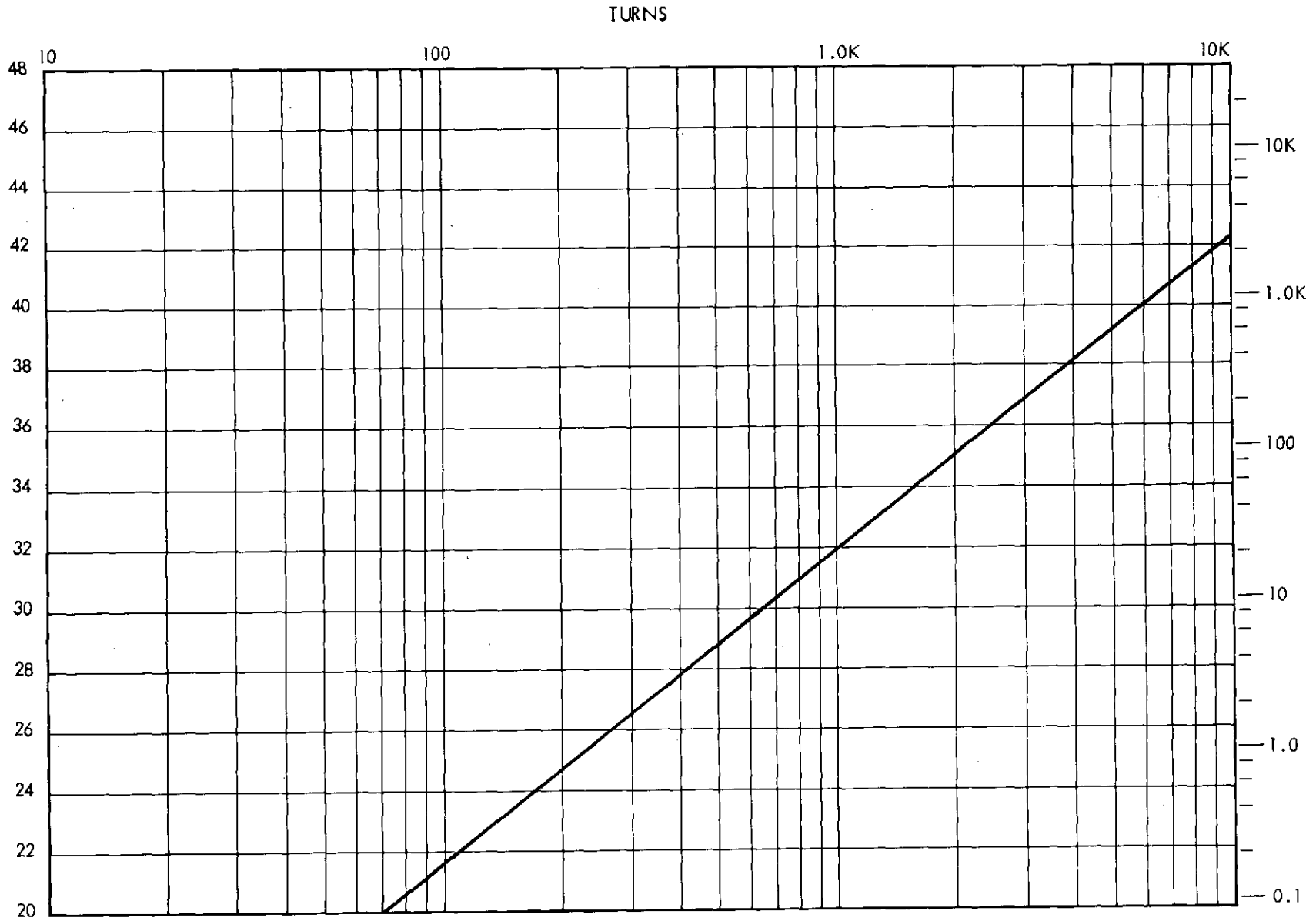
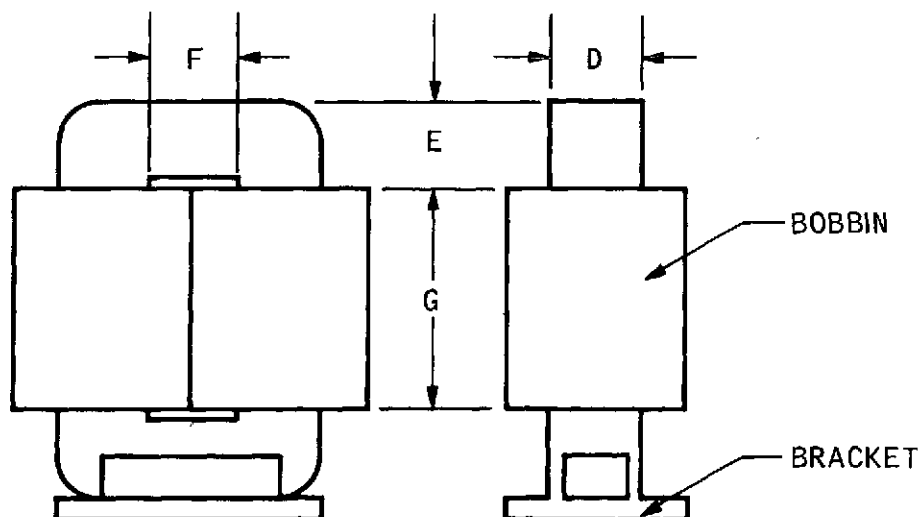

Fig. 39. Nomograph for "C" Core MC 8400

Table 31. "C" Core Magnetic Inc MC 1200

	ENGLISH	METRIC
Wa/Ac		3.98
Wa x Ac	0.035 in ⁴	1.467 cm ⁴
Ac	0.094 in ²	0.606 cm ²
Wa	0.375 in ²	2.419 cm ²
lm	3.475 in	8.83 cm
CORE wt SOLID	0.090 lb	40.8 grams
COPPER wt	0.088 lb	40. grams
MLT FULLWOUND	1.97 in	5.00 cm
MLT 1st HALF	1.73 in	4.39 cm
MLT 2nd HALF	2.21 in	5.61 cm
A _T	7.125 in ²	45.95 cm ²
D	0.375 in	0.953 cm
E	0.250 in	0.635 cm
F	0.375 in	0.953 cm
G	1.00 in	2.54 cm
BOBBIN	DORCO ELECTRONICS # 12771	
LENGTH	0.920 in	2.34 cm
BUILD	0.152 in	0.386 cm
AREA	0.140 in ²	0.902 cm ²
BRACKET	HALLMARK METALS # 06-014-04	



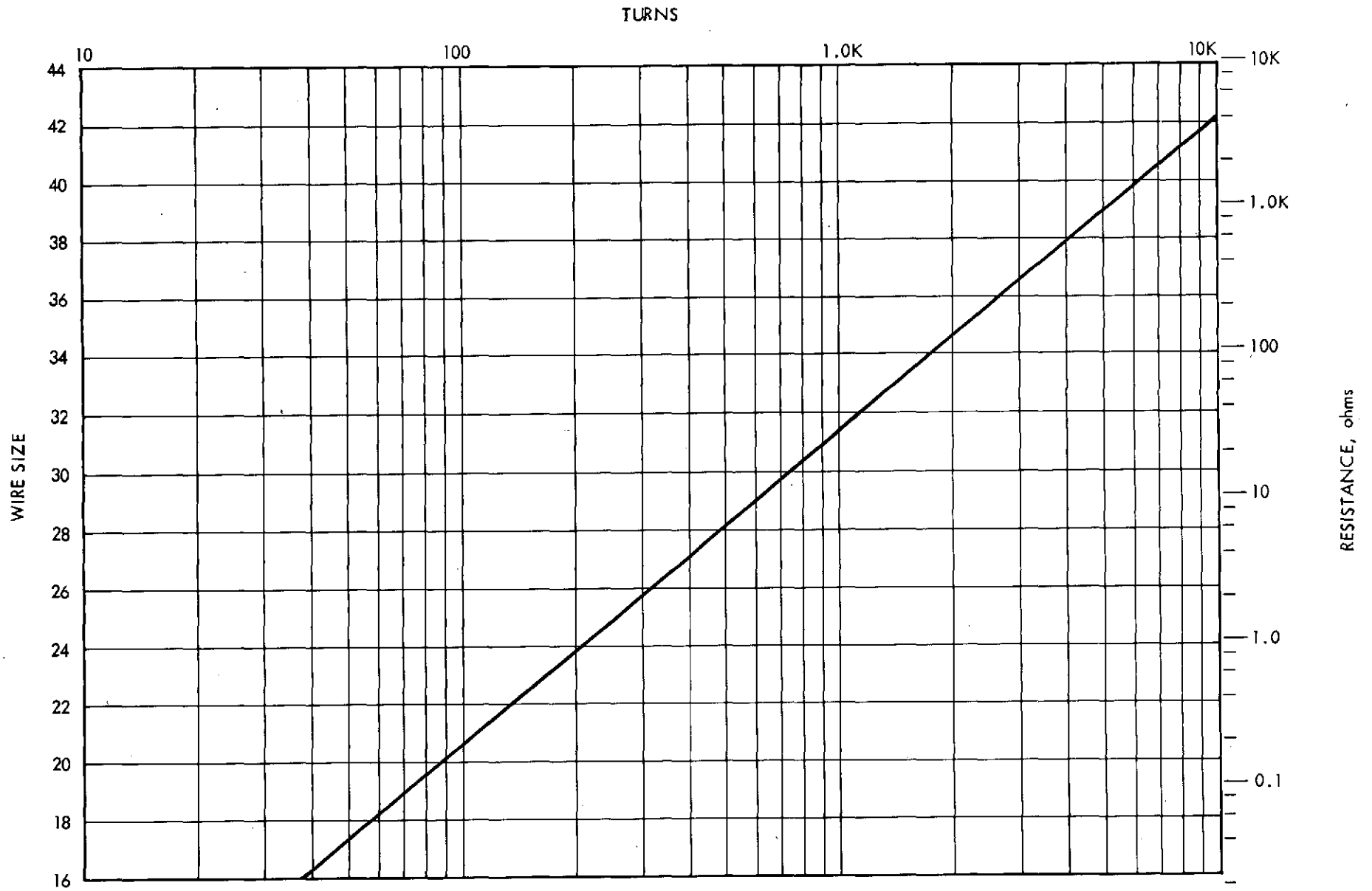
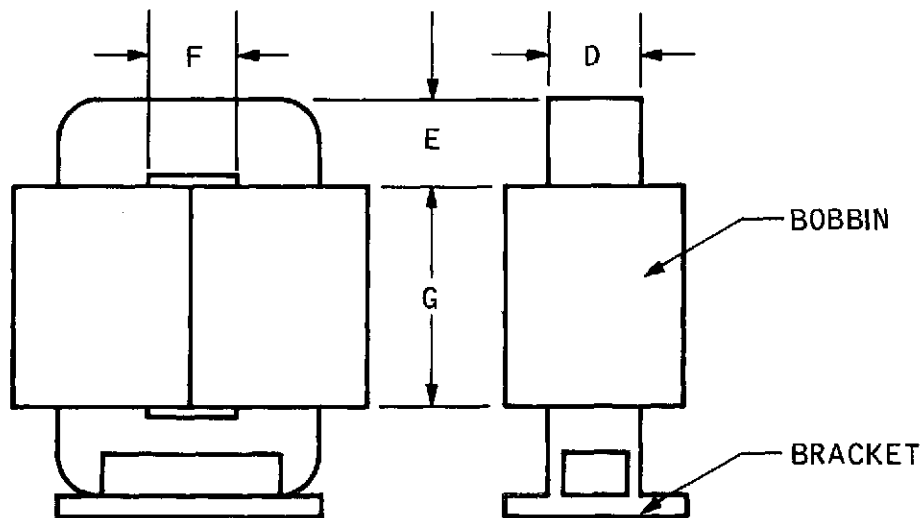

Fig. 40. Nomograph for "C" Core MC 1200

Table 32. "C" Core Magnetic Inc MC 4400

	ENGLISH	METRIC
Wa/Ac		3.96
Wa x Ac	0.062 in ⁴	2.600 cm ⁴
Ac	0.125 in ²	0.806 cm ²
Wa	0.500 in ²	3.225 cm ²
lm	3.725 in	9.46 cm
CORE wt SOLID	0.128 lb	58.3 grams
COPPER wt	0.14 lb	65 grams
MLT FULLWOUND	2.42 in	6.15 cm
MLT 1st HALF	2.10 in	5.33 cm
MLT 2nd HALF	2.74 in	6.96 cm
A _T	9.50 in ²	61.27 cm ²
D	0.50 in	1.27 cm
E	0.25 in	0.635 cm
F	0.50 in	1.27 cm
G	1.00 in	2.54 cm
BOBBIN	DORCO ELECTRONICS # 12772	
LENGTH	0.910 in	2.31 cm
BUILD	0.202 in	0.513 cm
AREA	0.184 in ²	1.186 cm ²
BRACKET	HALLMARK METALS # 08-100-04	



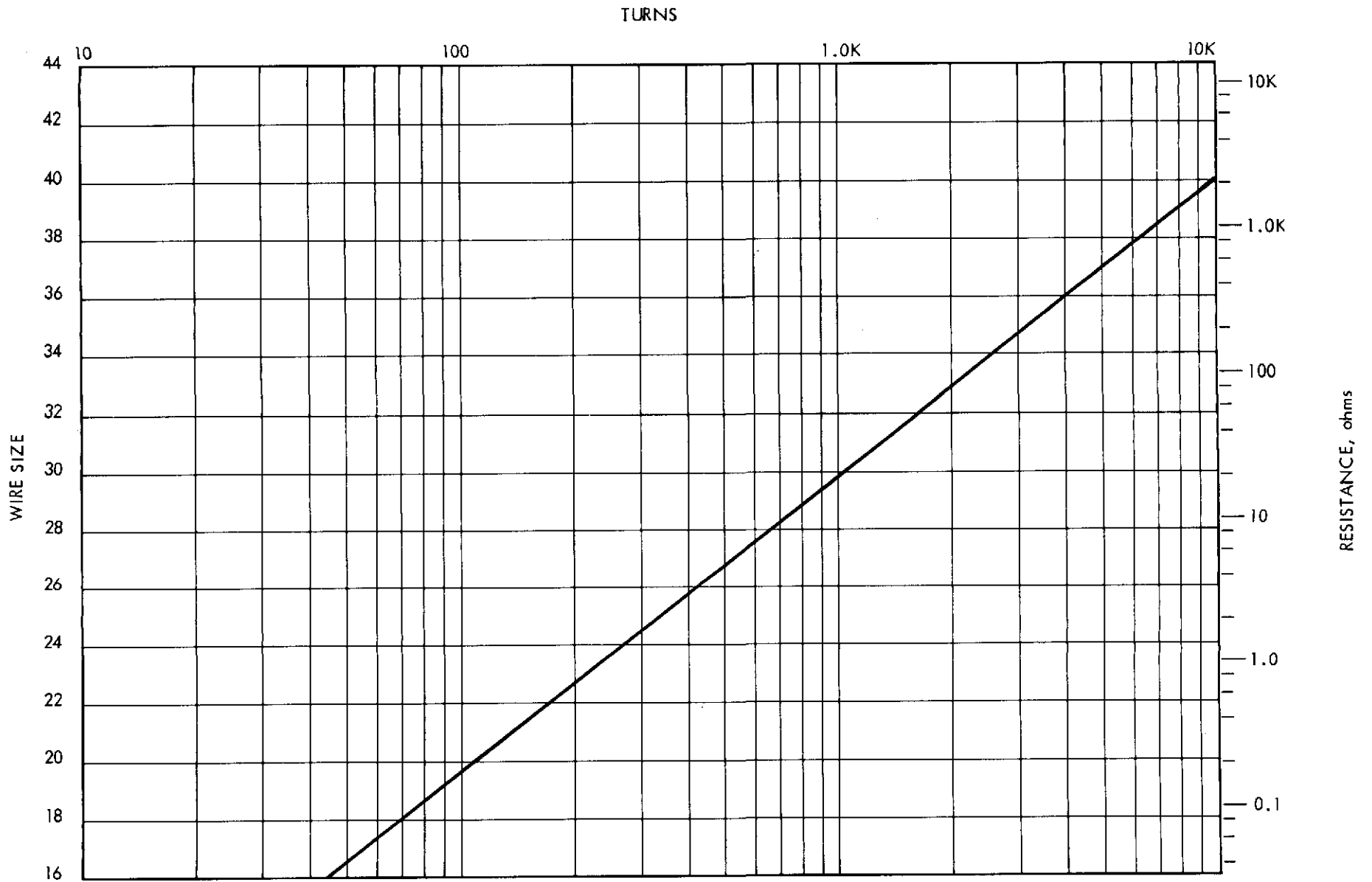
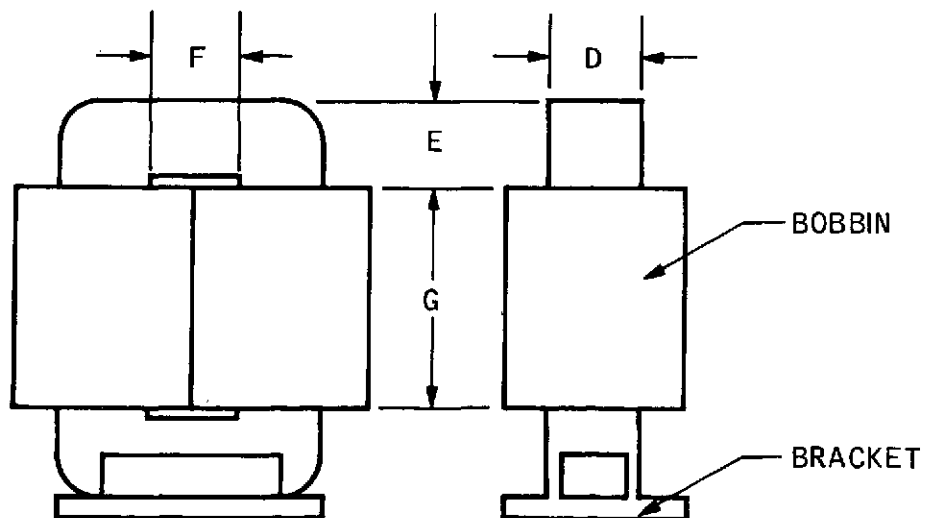

Fig. 41. Nomograph for "C" Core MC 4400

Table 33. "C" Core Magnetic Inc MC 2300

	ENGLISH	METRIC
Wa/Ac		6.97
Wa x Ac	0.109 in ⁴	4.55 cm ⁴
Ac	0.125 in ²	0.806 cm ²
Wa	0.875 in ²	5.643 cm ²
Im	5.23 in	13.27 cm
CORE wt SOLID	0.180 lb	81.8 grams
COPPER wt	0.255 lb	116 grams
MLT FULLWOUND	2.42 in	6.15 cm
MLT 1st HALF	2.10 in	5.33 cm
MLT 2nd HALF	2.74 in	6.96 cm
AT	13.25 in ²	85.46 cm ²
D	0.50 in	1.27 cm
E	0.25 in	0.635 cm
F	0.50 in	1.27 cm
G	1.75 in	4.45 cm
BOBBIN	DORCO ELECTRONICS # 12773	
LENGTH	1.660 in	4.22 cm
BUILD	0.202 in	0.513 cm
AREA	0.335 in ²	2.16 cm ²
BRACKET	HALLMARK METALS # 08-100-04	



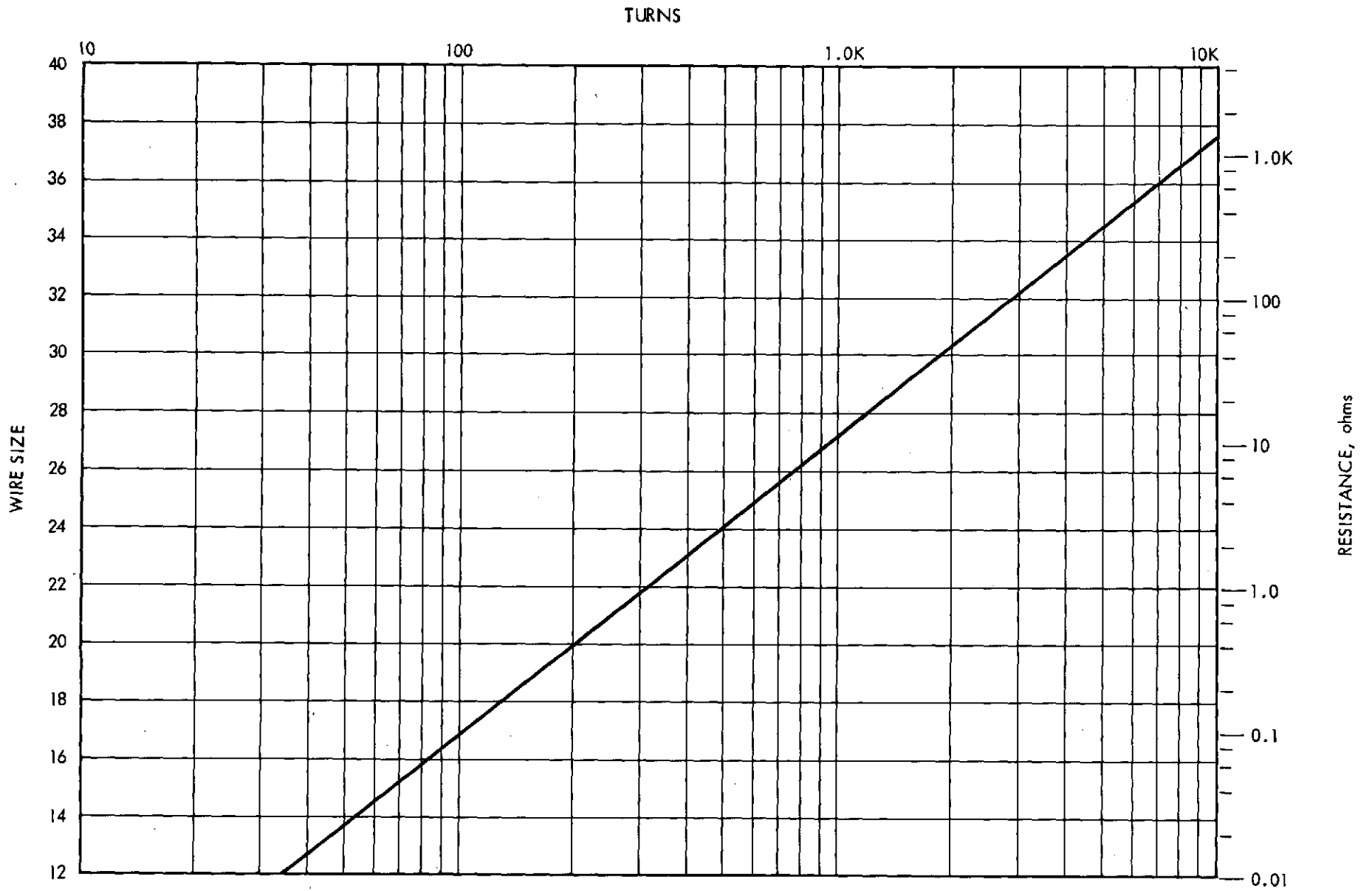
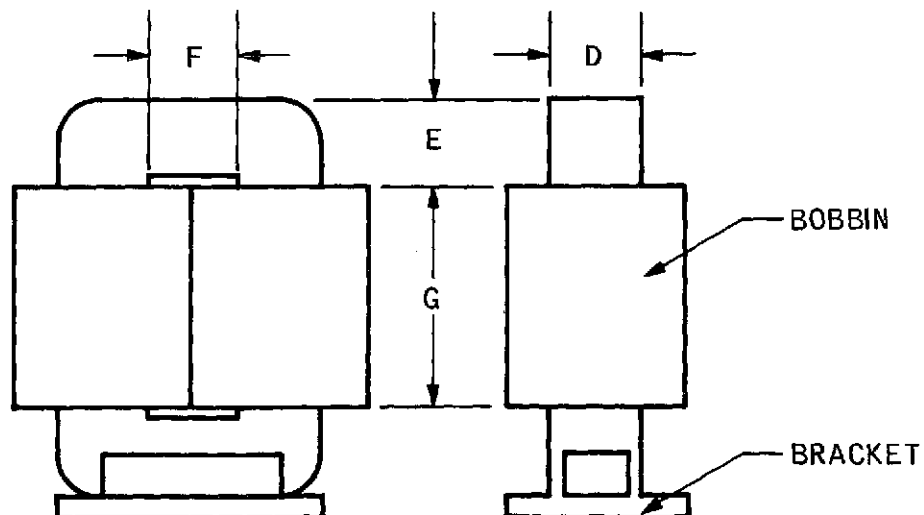

Fig. 42. Nomograph for "C" Core MC 2300

Table 34. "C" Core Magnetic Inc MC 1300

	ENGLISH	METRIC
Wa/Ac		4.15
Wa x Ac	0.146 in ⁴	6.1 cm ⁴
Ac	0.187 in ²	1.21 cm ²
Wa	0.781 in ²	5.04 cm ²
lm	5.57 in	14.16 cm
CORE wt SOLID	0.288 lb	130 grams
COPPER wt	0.242 lb	110 grams
MLT FULLWOUND	2.67 in	6.78 cm
MLT 1st HALF	2.35 in	5.97 cm
MLT 2nd HALF	2.99 in	7.59 cm
A _T	16.23 in ²	104.7 cm ²
D	0.375 in	0.952 cm
E	0.50 in	1.27 cm
F	0.50 in	1.27 cm
G	1.562 in	3.97 cm
BOBBIN	DORCO ELECTRONICS #12774	
LENGTH	1.470 in	3.73 cm
BUILD	0.202 in	0.513 cm
AREA	0.297 in ²	1.915 cm ²
BRACKET	HALLMARK METALS # 06-108-08	



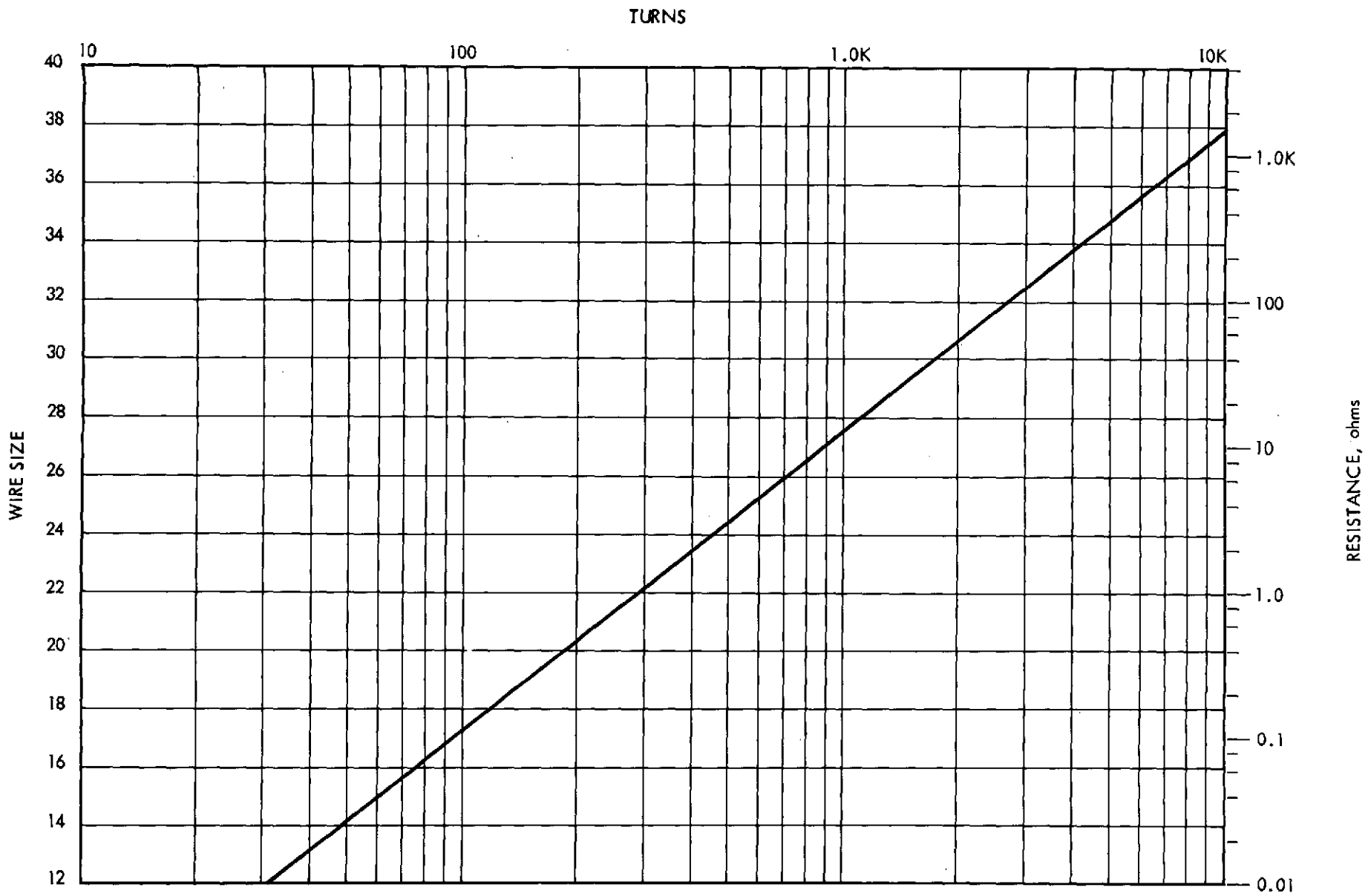
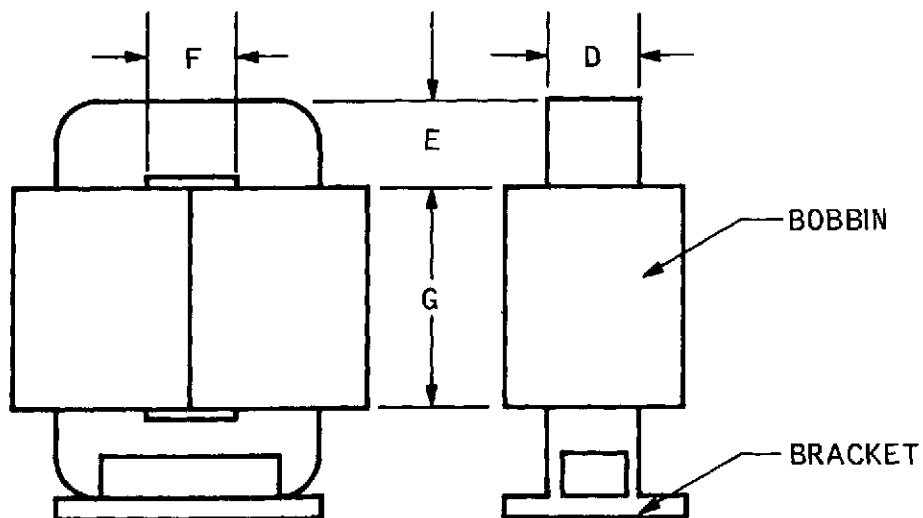

Fig. 43. Nomograph for "C" Core MC 1300

Table 35. "C" Core Magnetic Inc MC 0014

	ENGLISH	METRIC
Wa/Ac		3.12
Wa x Ac	0.195 in ⁴	8.11 cm ⁴
Ac	0.250 in ²	1.61 cm ²
Wa	0.781 in ²	5.04 cm ²
lm	5.574 in	14.2 cm
CORE wt SOLID	0.384 lb	174.0 grams
COPPER wt	0.264 lb	120 grams
MLT FULLWOUND	2.92 in	7.42 cm
MLT 1st HALF	2.60 in	6.60 cm
MLT 2nd HALF	3.24 in	8.23 cm
AT	17.37 in ²	112.0 cm ²
D	0.50 in	1.27 cm
E	0.50 in	1.27 cm
F	0.50 in	1.27 cm
G	1.562 in	3.97 cm
BOBBIN	DORCO ELECTRONICS # 12775	
LENGTH	1.470 in	3.73 cm
BUILD	0.202 in	0.513 cm
AREA	0.297 in ²	1.915 cm ²
BRACKET	HALLMARK METALS # 08-108-08	



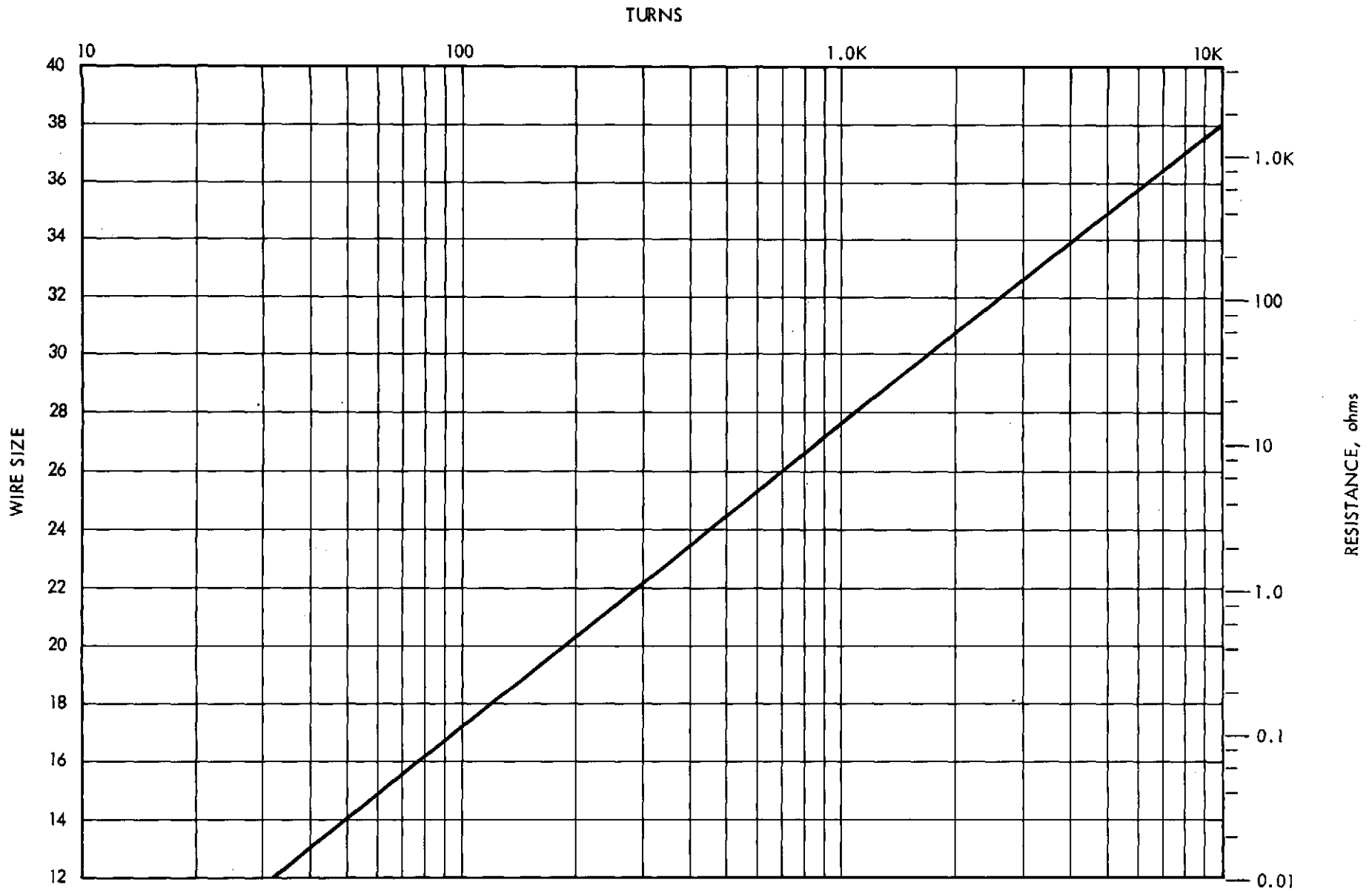
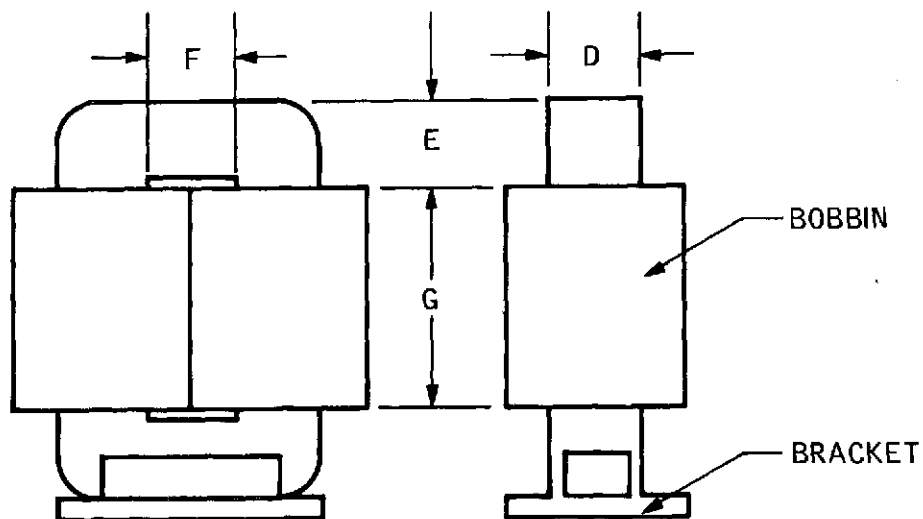

Fig. 44. Nomograph for "C" Core MC 0014

Table 36. "C" Core Magnetic Inc MC 1030

	ENGLISH	METRIC
Wa/Ac		3.28
Wa x Ac	0.26 in ⁴	10.93 cm ⁴
Ac	0.281 in ²	1.81 cm ²
Wa	0.937 in ²	6.04 cm ²
Im	5.34 in	13.5 cm
CORE wt SOLID	0.415 lb	188 grams
COPPER wt	0.434 lb	197 grams
MLT FULLWOUND	3.39 in	8.61 cm
MLT 1st HALF	2.98 in	7.57 cm
MLT 2nd HALF	3.80 in	9.65 cm
AT	18.81 in ²	121.3 cm ²
D	0.750 in	1.905 cm
E	0.375 in	0.952 cm
F	0.625 in	1.587 cm
G	1.500 in	3.81 cm
BOBBIN	DORCO ELECTRONICS # 12776	
LENGTH	1.470 in	3.73 cm
BUILD	0.260 in	0.660 cm
AREA	0.382 in ²	2.46 cm ²
BRACKET	HALLMARK METALS # 012-106-06	



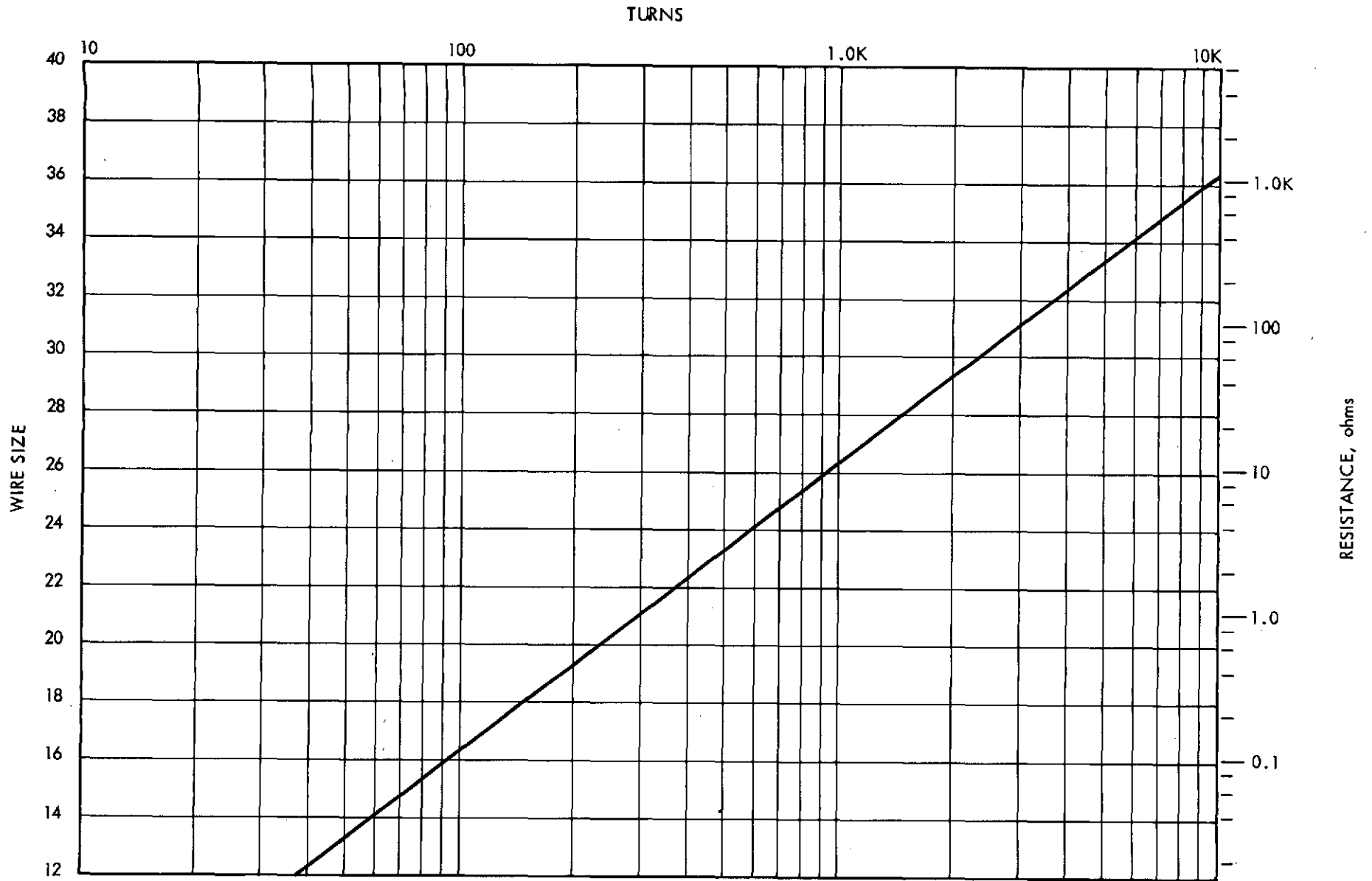
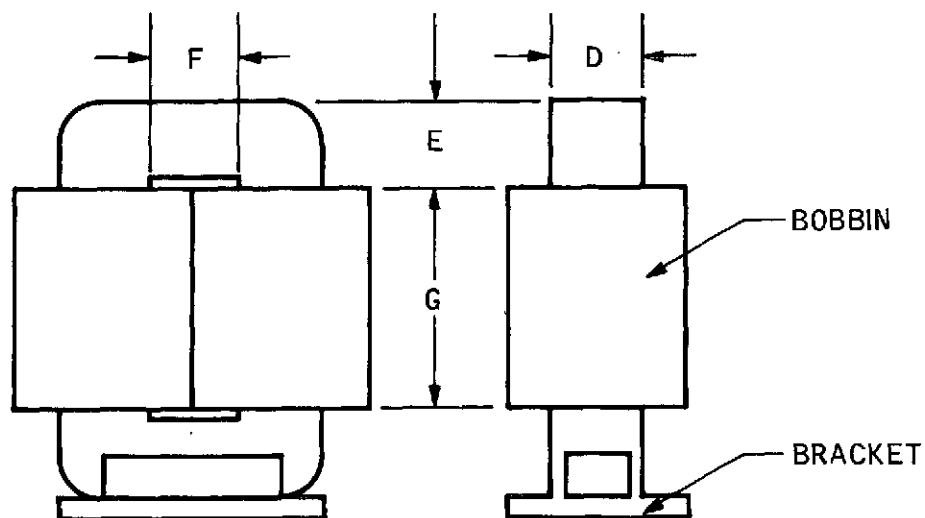

Fig. 45. Nomograph for "C" Core MC 1030

Table 37. "C" Core Magnetic Inc MC 1000

	ENGLISH	METRIC
Wa/Ac		3.11
Wa x Ac	0.474 in ⁴	19.68 cm ⁴
Ac	0.3906 in ²	2.517 cm ²
Wa	1.210 in ²	7.82 cm ²
lm	6.25 in	15.9 cm
CORE wt SOLID	0.674 lb	306 grams
COPPER wt	0.414 lb	188 grams
MLT FULLWOUND	3.99 in	10.13 cm
MLT 1st HALF	3.59 in	9.12 cm
MLT 2nd HALF	4.39 in	11.15 cm
A _T	24.52 in ²	158.2 cm ²
D	1.00 in	2.54 cm
E	0.3906 in	0.991 cm
F	0.625 in	1.59 cm
G	1.937 in	4.92 cm
BOBBIN	DORCO ELECTRONICS # 12777	
LENGTH	1.846 in	4.68 cm
BUILD	0.255 in	0.647 cm
AREA	0.470 in ²	3.04 cm ²
BRACKET	HALLMARK METALS # 10-107-06	



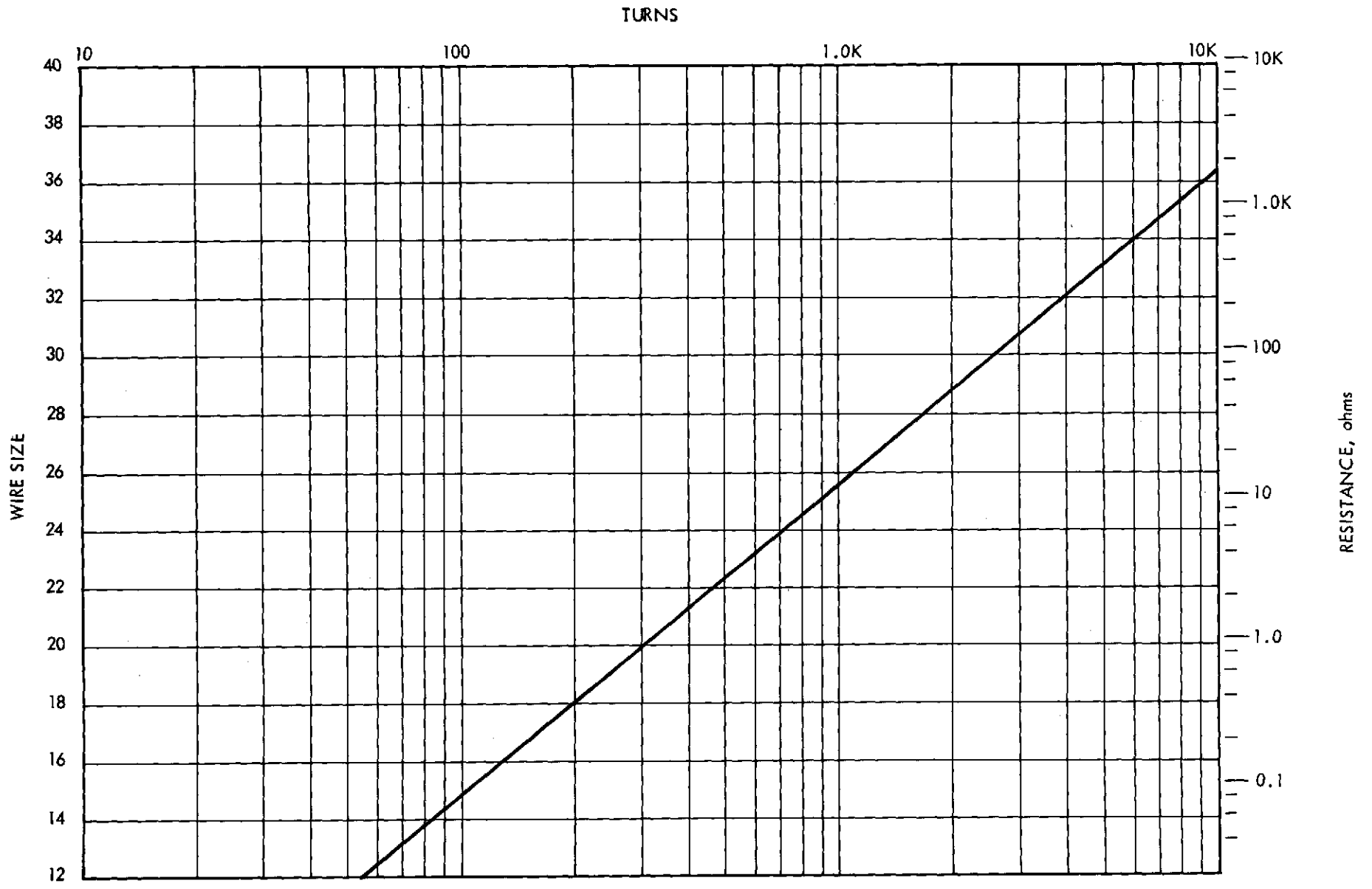
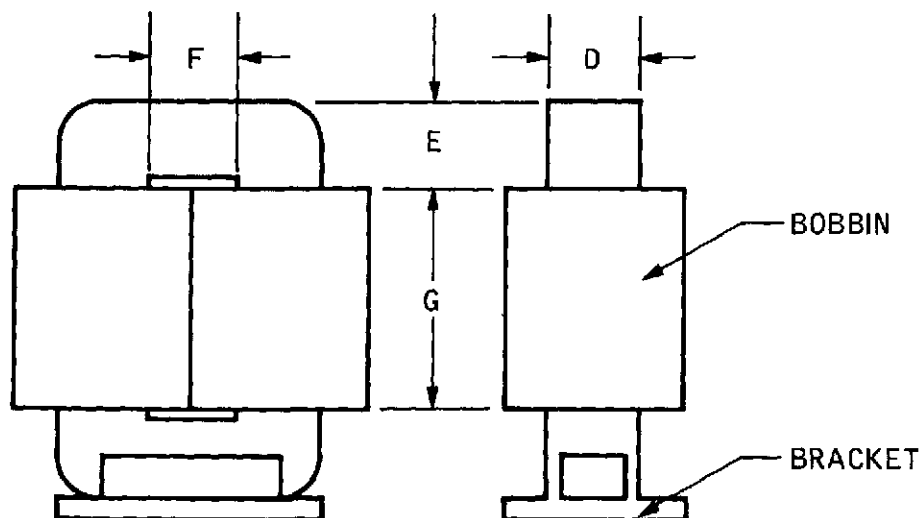

Fig. 46. Nomograph for "C" Core MC 1000

Table 38. "C" Core Magnetic Inc MC 1610

	ENGLISH	METRIC
Wa/Ac		9.0
Wa x Ac	0.563 in ⁴	23.39 cm ⁴
Ac	0.250 in ²	1.61 cm ²
Wa	2.250 in ²	14.51 cm ²
lm	7.46 in	18.95 cm
CORE wt SOLID	0.515 lb	233 grams
COPPER wt	1.38 lb	626 grams
MLT FULLWOUND	4.48 in	11.38 cm
MLT 1st HALF	3.38 in	8.58 cm
MLT 2nd HALF	5.58 in	14.17 cm
AT	40 in ²	258 cm ²
D	0.50 in	1.27 cm
E	0.50 in	1.27 cm
F	1.50 in	3.81 cm
G	1.50 in	3.81 cm
BOBBIN	DORCO ELECTRONICS # 12778	
LENGTH	1.41 in	3.58 cm
BUILD	0.70 in	1.78 cm
AREA	0.987 in ²	6.37 cm ²
BRACKET	HALLMARK METALS # 08-208-08	



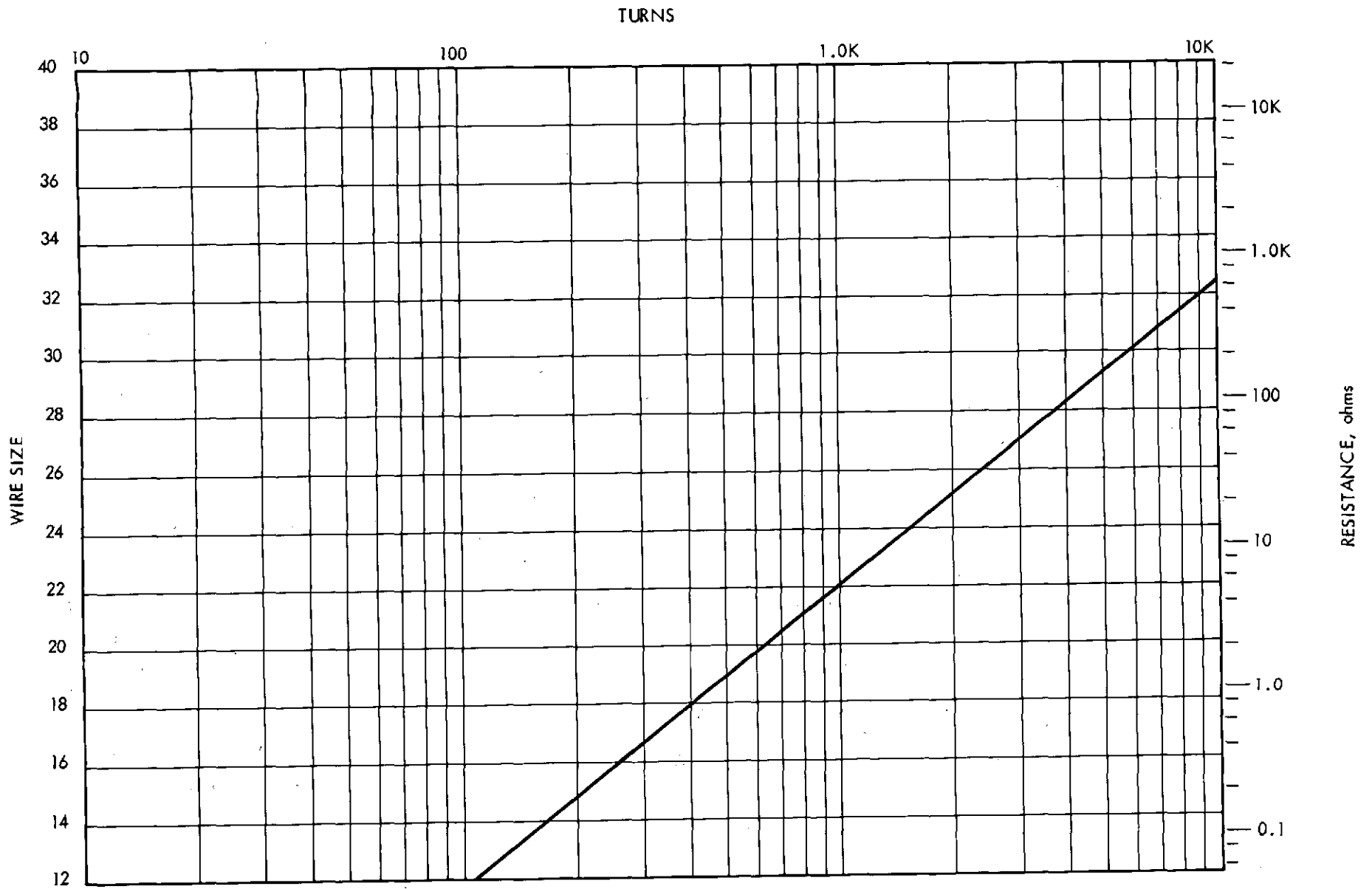
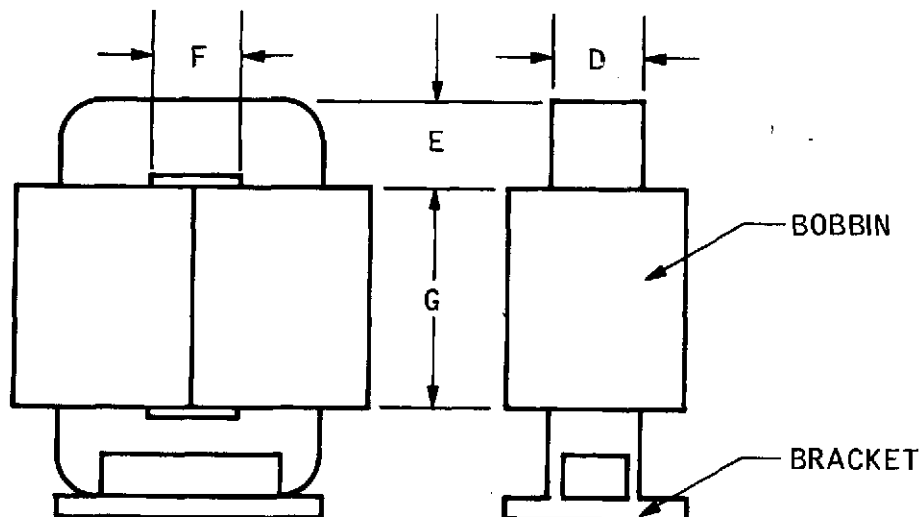

Fig. 47. Nomograph for "C" Core MC 1610

Table 39. "C" Core Magnetic Inc MC 2000

	ENGLISH	METRIC
Wa/Ac		6.22
Wa x Ac	0.947 in ⁴	39.36 cm ⁴
Ac	0.3906 in ²	2.52 cm ²
Wa	2.42 in ²	15.62 cm ²
lm	7.5 in	19.07 cm
CORE wt SOLID	0.808 lb	366 grams
COPPER wt	1.64 lb	744 grams
MLT FULLWOUND	5.02 in	12.75 cm
MLT 1st HALF	4.11 in	10.44 cm
MLT 2nd HALF	5.91 in	15.01 cm
AT	40.9 in ²	264 cm ²
D	1.00 in	2.54 cm
E	0.3906 in	0.992 cm
F	1.25 in	3.175 cm
G	1.937 in	4.92 cm
BOBBIN	DORCO ELECTRONICS # 12779	
LENGTH	1.845 in	4.69 cm
BUILD	0.575 in	1.46 cm
AREA	1.061 in ²	6.84 cm ²
BRACKET	HALLMARK METALS # 10-202-07	



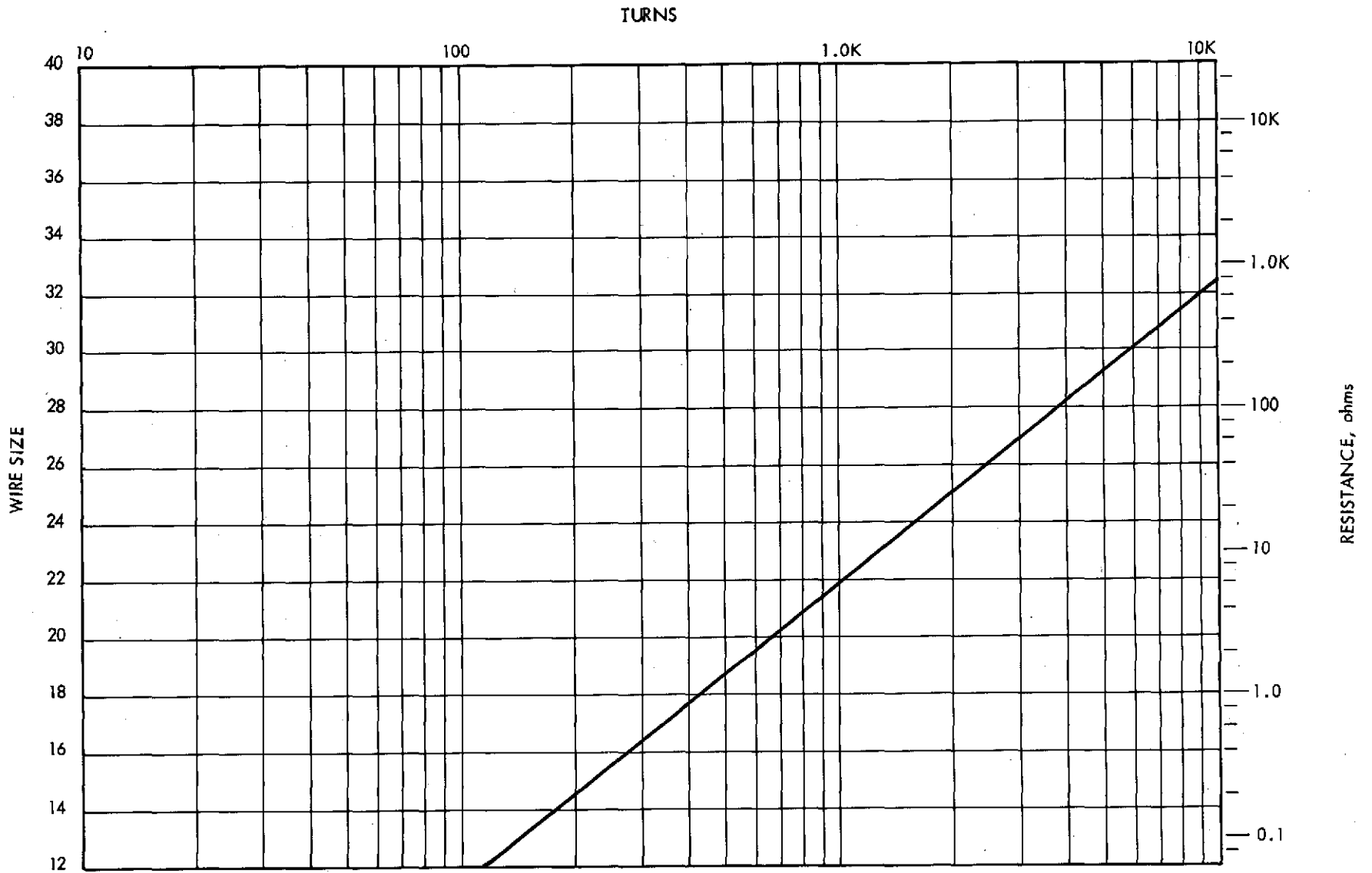
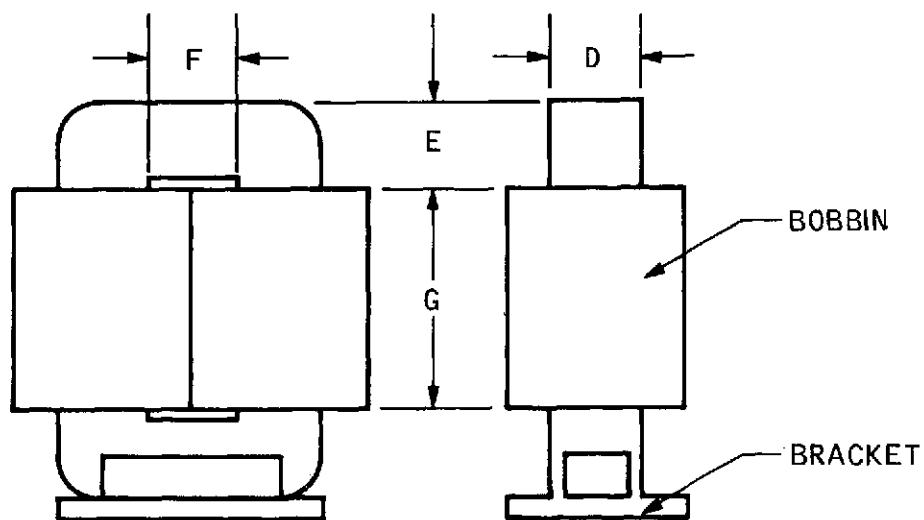

Fig. 48. Nomograph for "C" Core MC 2000

Table 40. "C" Core Magnetic Inc MC 6800

	ENGLISH	METRIC
Wa/Ac		3.08
Wa x Ac	0.976 in ⁴	40.65 cm ⁴
Ac	0.563 in ²	3.63 cm ²
Wa	1.734 in ²	11.20 cm ²
lm	7.21 in	18.31 cm
CORE wt SOLID	1.105 lb	501 grams
COPPER wt	1.25 lb	568 grams
MLT FULLWOUND	5.18 in	13.16 cm
MLT 1st HALF	4.68 in	11.88 cm
MLT 2nd HALF	5.69 in	14.45 cm
A _T	35.43 in ²	228.5 cm ²
D	1.50 in	3.81 cm
E	0.375 in	0.952 cm
F	0.750 in	1.905 cm
G	2.312 in	5.873 cm
BOBBIN	DORCO ELECTRONICS #12780	
LENGTH	2.222 in	5.64 cm
BUILD	0.322 in	0.818 cm
AREA	0.715 in ²	4.61 cm ²
BRACKET	HALLMARK METALS # 18-108-06	



WIRE SIZE

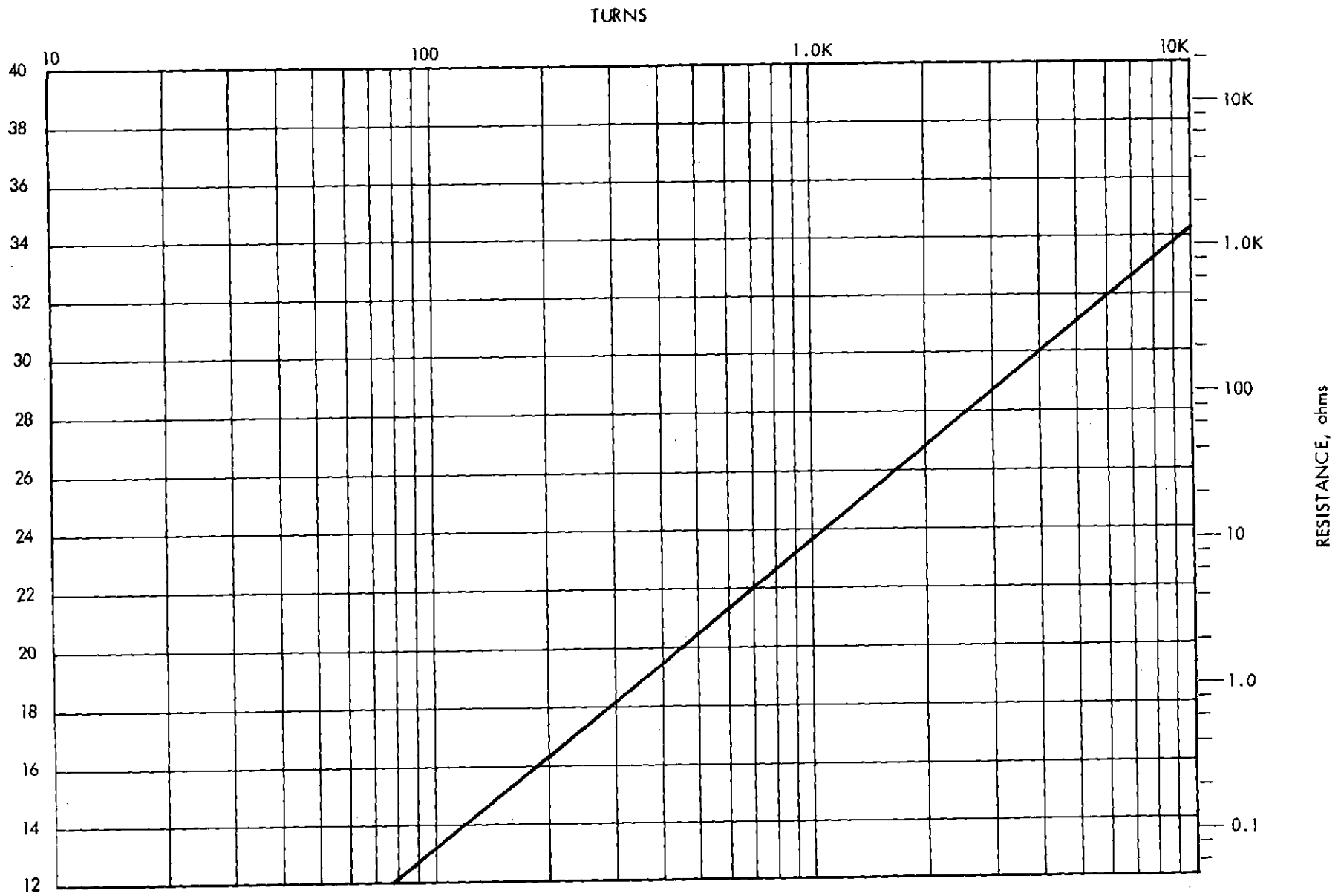
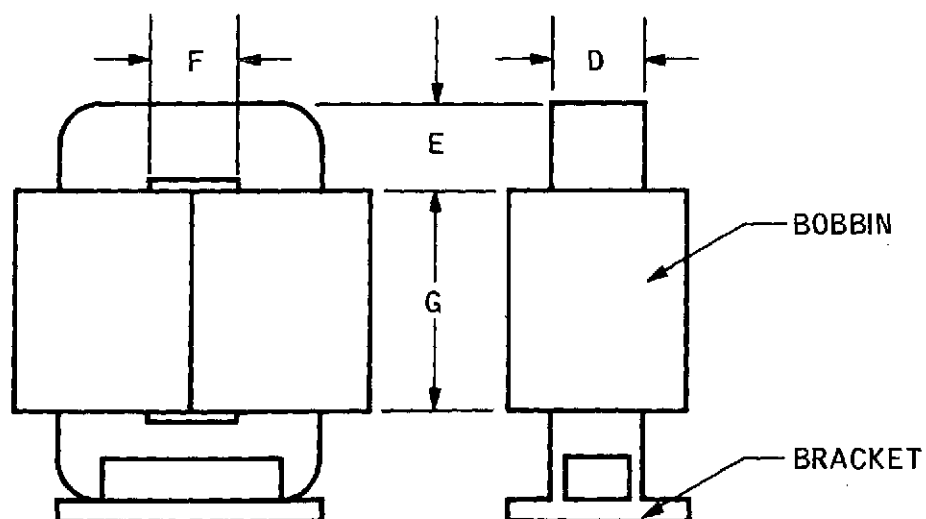

Fig. 49. Nomograph for "C" Core MC 6800

Table 41. "C" Core Magnetic Inc MC 1620

	ENGLISH	METRIC
Wa/Ac		5.44
Wa x Ac	1.72 in ⁴	71.73 cm ⁴
Ac	0.562 in ²	3.625 cm ²
Wa	3.063 in ²	19.76 cm ²
Im	9.175 in	23.3 cm
CORE wt SOLID	1.42 lb	646 grams
COPPER wt	2.47 lb	1120 grams
MLT FULLWOUND	5.9 in	14.99 cm
MLT 1st HALF	4.61 in	11.71 cm
MLT 2nd HALF	7.19 in	18.26 cm
AT	63.25 in ²	408 cm ²
D	0.750 in	1.905 cm
E	0.750 in	1.905 cm
F	1.750 in	4.45 cm
G	1.750 in	4.45 cm
BOBBIN	DORCO ELECTRONICS # 12781	
LENGTH	1.630 in	4.14 cm
BUILD	0.820 in	2.08 cm
AREA	1.34 in ²	8.62 cm ²
BRACKET	HALLMARK METALS #012-304-012	



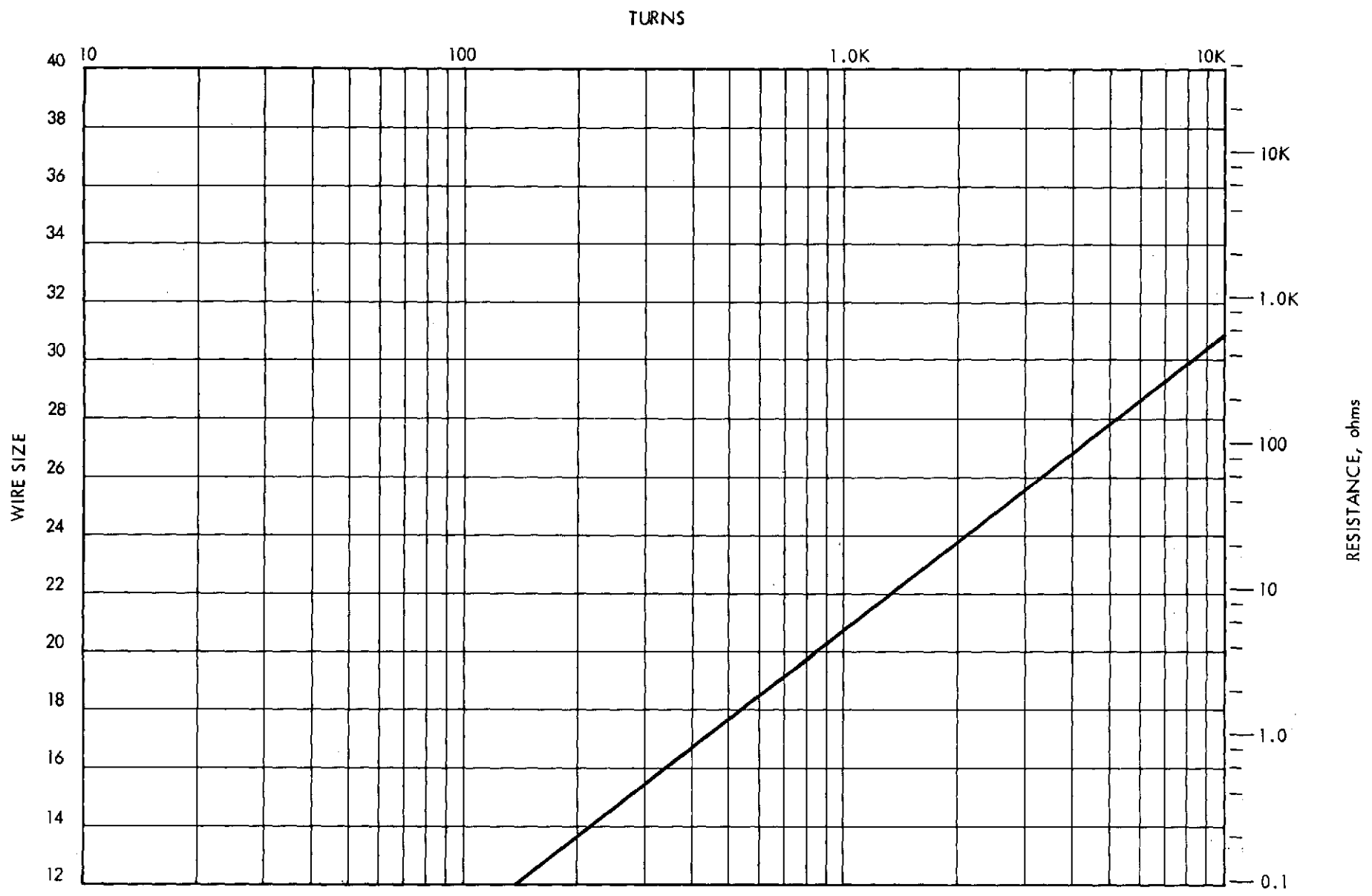

Fig. 50. Nomograph for "C" Core MC 1620

XII. TEMPERATURE RISE VERSUS SURFACE AREA DISSIPATION DUE TO POWER LOSS, Figure 51:

Power loss (core loss + winding loss) in a transformer produces a temperature rise which must be controlled to prevent damage or failure. Heat is dissipated from the transformer surfaces by a combination of radiation and convection and is dependent upon total exposed surface area. Dissipation is expressed in watts per square centimeter of surface area.

Temperature rise in a transformer winding cannot be predicted with complete precision. Many different techniques are described in the literature for the computation of transformer temperature rise.

A method for temperature rise computation used by transformer designers is reasonably accurate for open core and coil construction. It is based on the assumptions that core and coil losses are lumped together and that this energy is dissipated through the circumferential area of the coil and core.

The nomograph of Fig. 51 (data obtained from Ref. 5) shows temperature rise versus power loss (core loss + copper loss) expressed in watts per square centimeter of surface area with heat transfer by combined radiation and convection.

The nomograph is based on heat transfer from a vertical surface by 45 percent convection and 55 percent radiation with an emissivity of 0.95 in a 25°C room at sea level. The heat loss from the upper side of a flat horizontal surface by convection is on the order of 15 to 20 percent more than from the vertical surface. On the under side the heat loss depends on the area and conductivity of the surface.

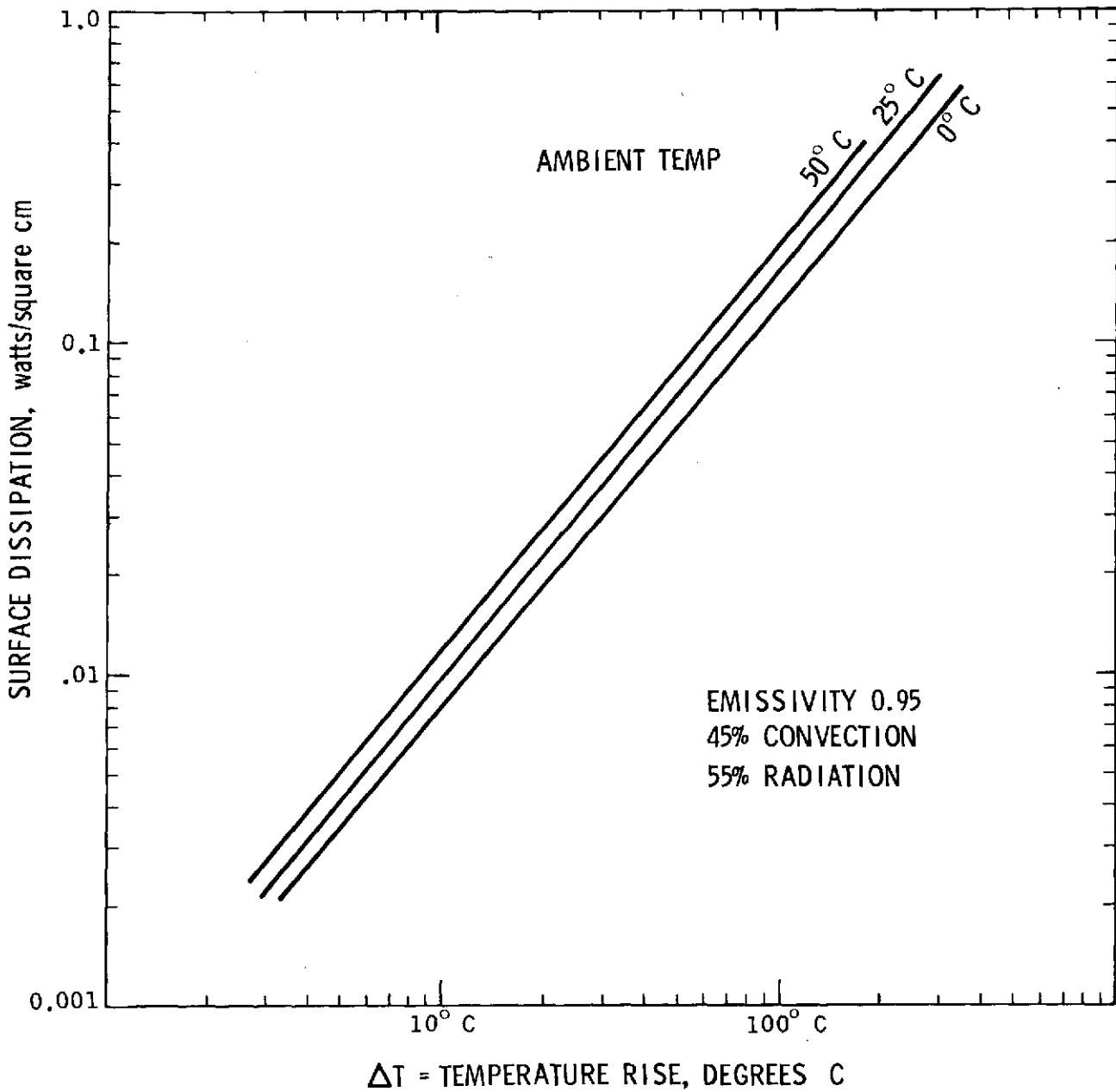

Fig. 51. Temperature Rise Versus Surface Dissipation

XIII. MAXIMUM PERMISSIBLE CURRENT DENSITY FOR 50°C RISE,
 Figures 52, 53 and 54

The curves shown are based upon a maximum permissible temperature rise of 50°C, with a surface dissipation of 0.07 watts/cm². Maximum efficiency is achieved when the iron power loss and the copper power loss are equal. The data are based upon an assumption of 50% iron and 50% copper power losses. Surface areas for toroidal cores, laminations, and C cores have been calculated. Power dissipated as heat in the transformer is:

$$A_t(\text{cm}^2) \cdot 0.07 \text{ Watts/cm}^2 = W_T$$

$$W_c = W_I = W_T/2$$

$$W_a(\text{cm}^2) \cdot N/\text{cm}^2 = N$$

W_c = Copper Loss

W_I = Iron Loss

$$R = N \cdot \Omega/\text{cm} \cdot \text{MLT}$$

W_T = Total Loss

$$W_c = I^2 R$$

N = Number of Turns (for a given wire size)

$$I = \sqrt{W_c/R}$$

N/cm^2 = Table I (K) for a given wire size

W_a = Window Area

$$\text{Current Density } I/\text{cm}^2 = I/\text{Wire Area (cm}^2)$$

These current densities are useful in picking out a first choice of wire size for a given current requirement but should not be regarded as final. Instead, the regulation, or other performance criteria should govern the final choice of wire size.

The surface area A_t for the toroids, laminations, and C cores were computed from Figs. 55, 56 and 57. Designation for terms are taken from tables of toroids, laminations, and C cores in this text.

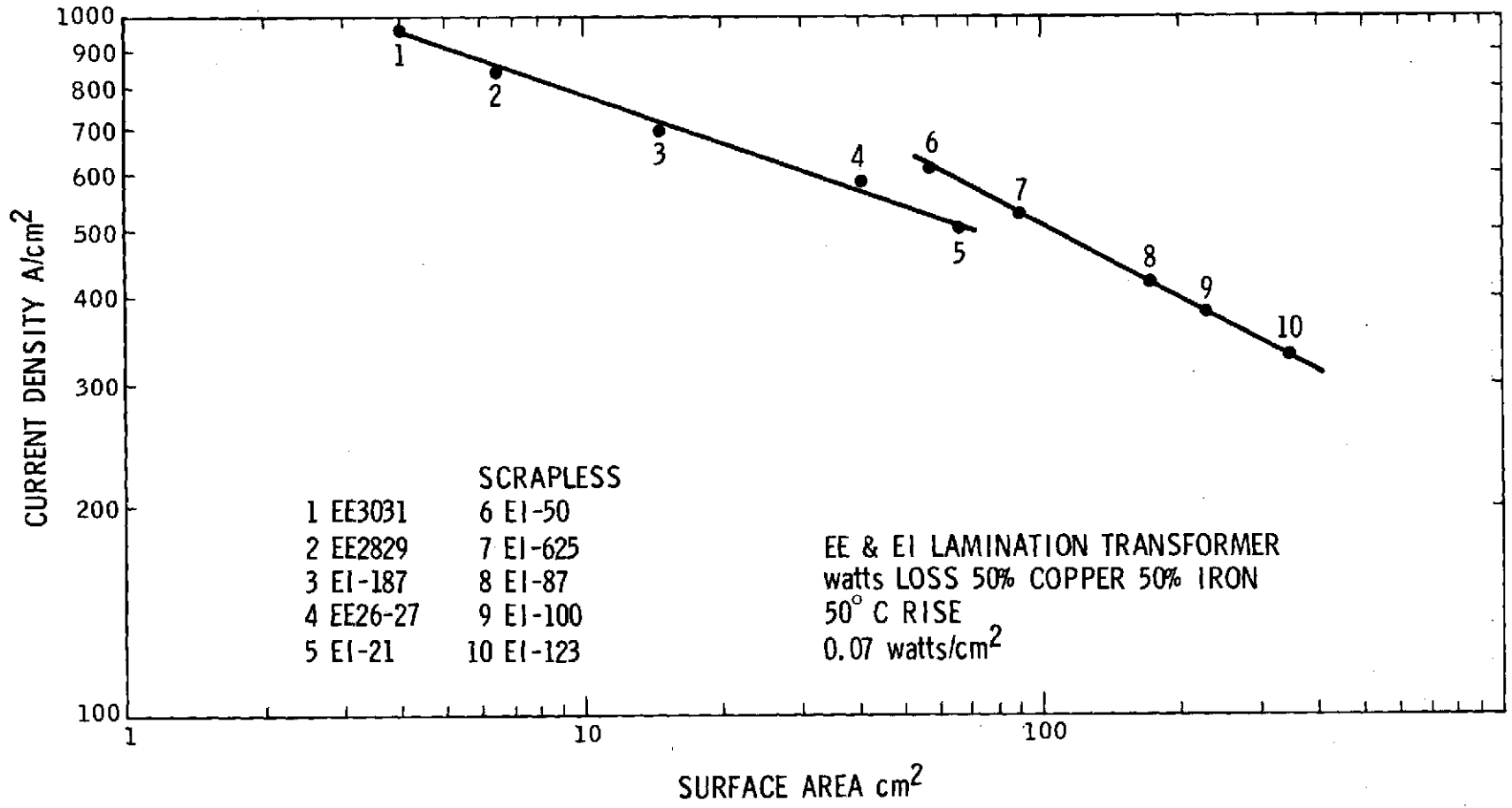

Fig. 52. Current Density vs Surface Area for a 50° C Rise (Lamination)

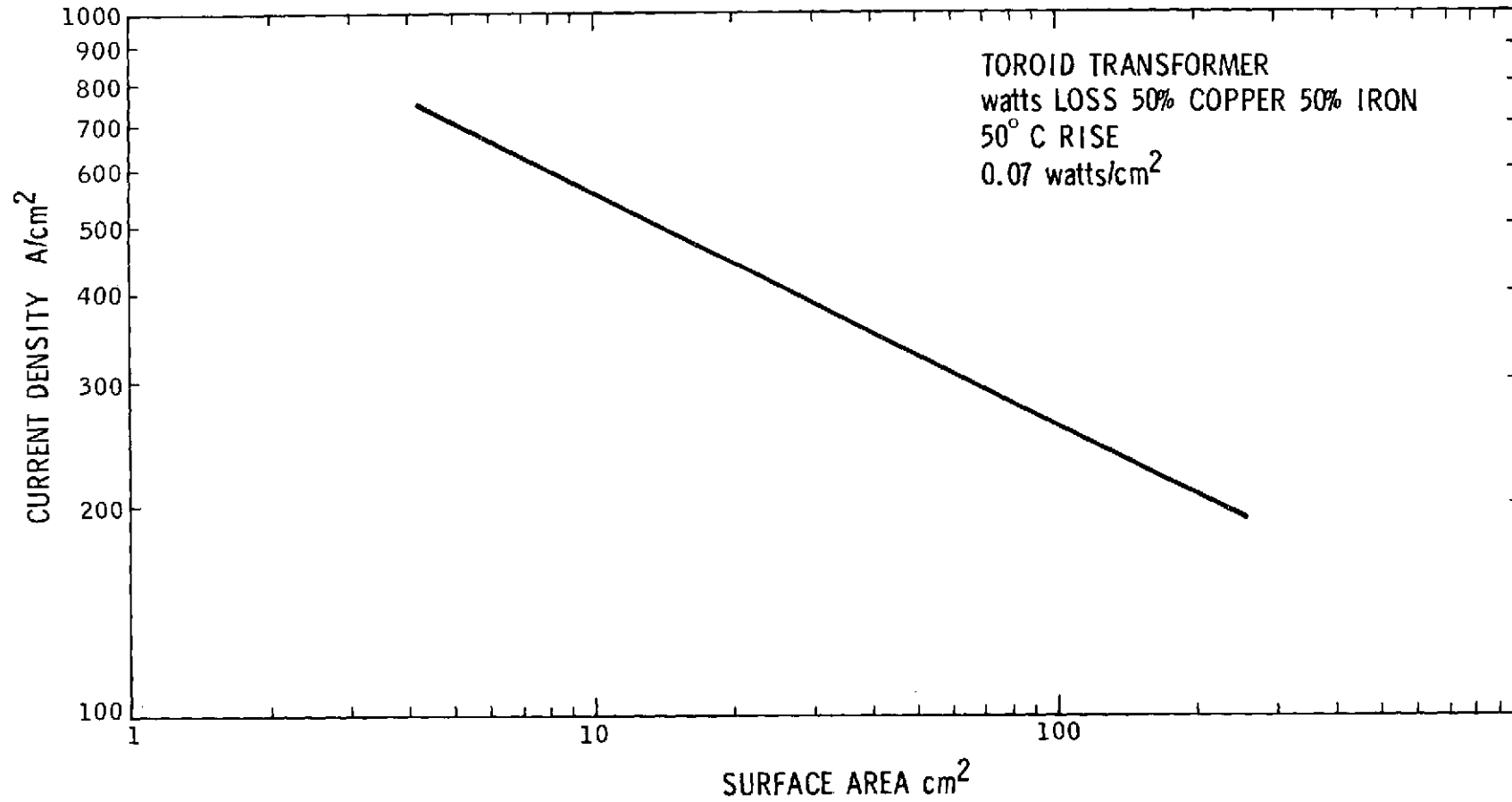

Fig. 53. Current Density vs Surface Area for a 50° C Rise (Toroid)

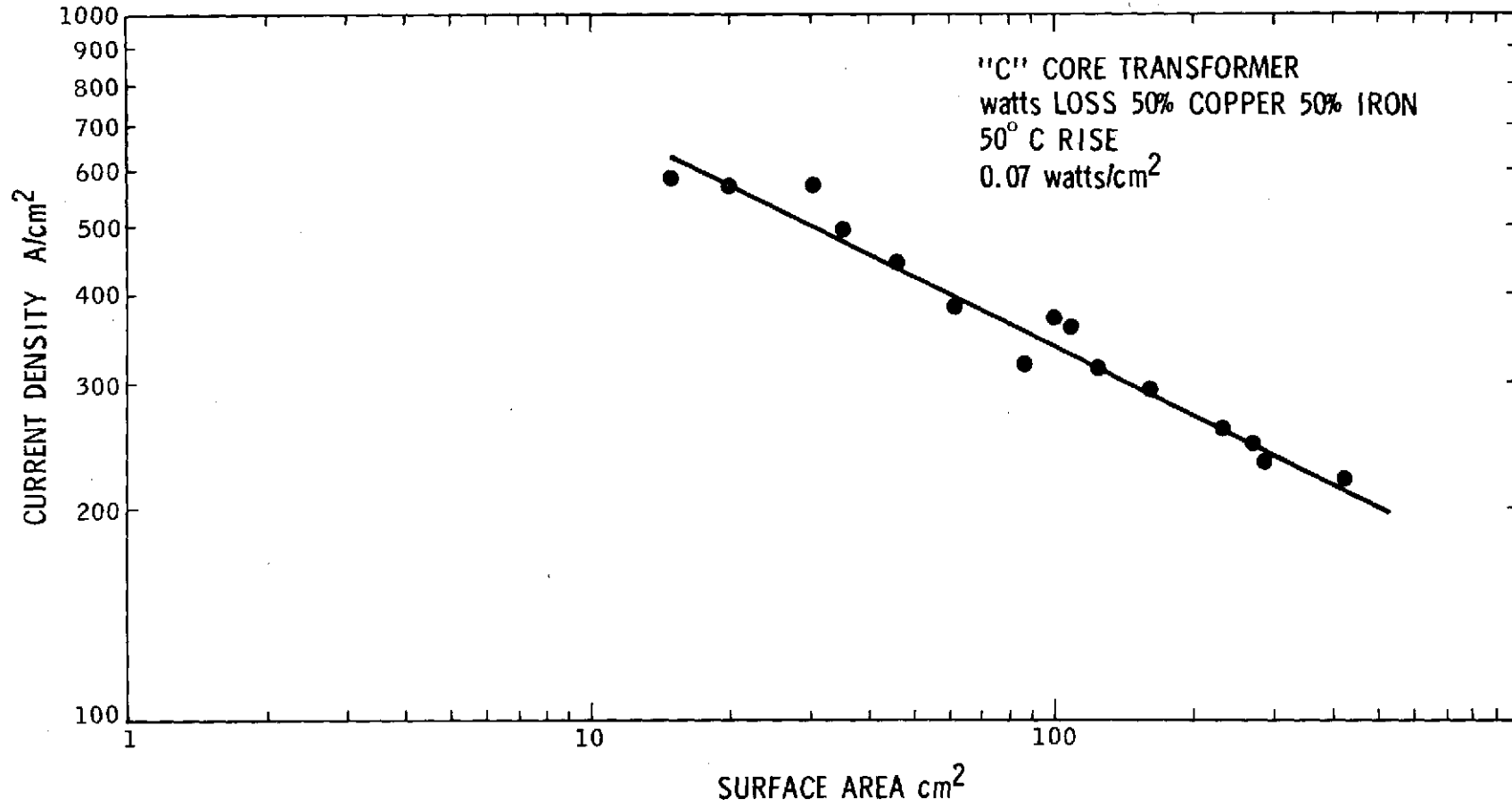
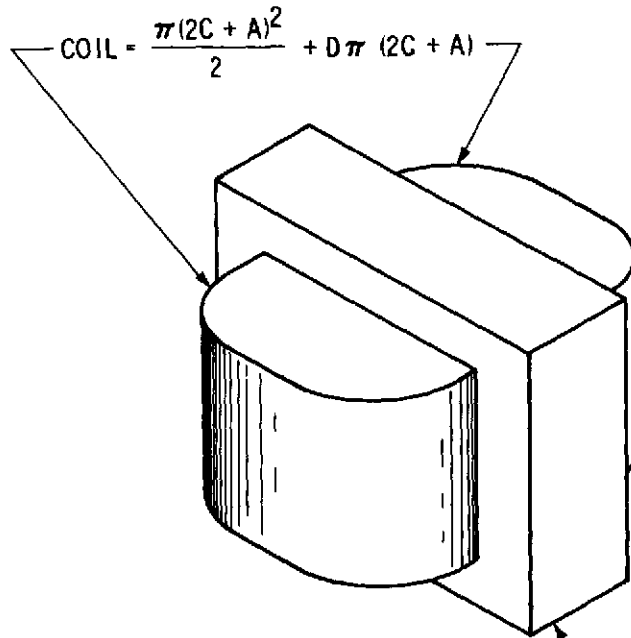

Fig. 54. Current Density vs Surface Area for a 50° C Rise (C Cores)



$$\text{COIL} = \frac{\pi(2C + A)^2}{2} + D\pi(2C + A)$$

A_t = SURFACE AREA

$$A_t \text{ LAMINATION} = 2(FE + SF + SE - DA - 2DC)$$

S = BUILD

$$A_t = \frac{\pi(2C + A)^2}{2} + D\pi(2C + A) + 2(FE + SF + SE - DA - 2DC)$$

Fig. 55. Lamination A_t

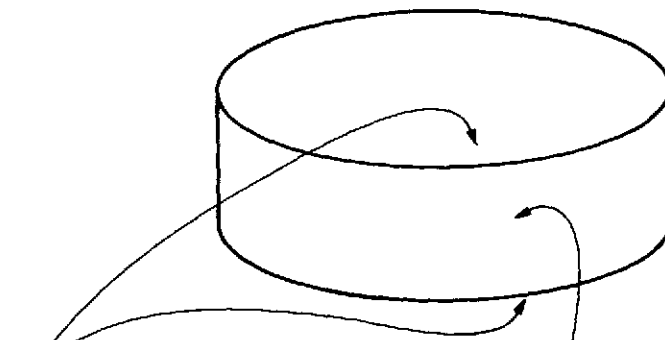

A_t = SURFACE AREA

$$A_t = \frac{\pi OD^2}{2} \text{ WOUND} + \pi OD_{\text{WOUND}} X_{\text{HT CORE}} + OD_{\text{WOUND}} - OD_{\text{CORE}}$$

Fig. 56. Toroid A_t

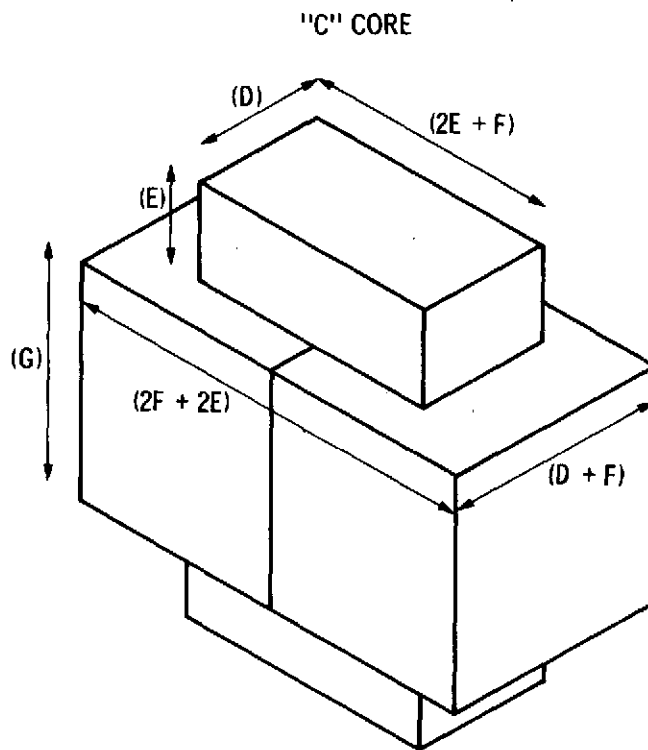

A_t - SURFACE AREA

$$A_t = 4E(2E+F) + (ED) 4 + 2(D+F)(G) + 2(2F+2E)(G) + 2(D+F)(2F+2E)$$

Fig. 57. C Core A_t

XIV. PERMEABILITY AND AIR GAP

The permeability of a magnetic core is decreased by inserting an air gap. Inserting an air gap causes the magnetization curve to "shear over." The size of air gap can be varied by different stacking methods.

Normal Permeability (μ^*) is the slope of a line drawn through the tips of a hysteresis loop formed at a specified value of H or B, as shown in Fig. 58. For the maximum flux density B_m , the normal permeability is:

$$\mu = \frac{B_m}{H}$$

*This is not to be confused with $\mu\Delta$ or μ_d per manufacturer's data (Ref. 6).

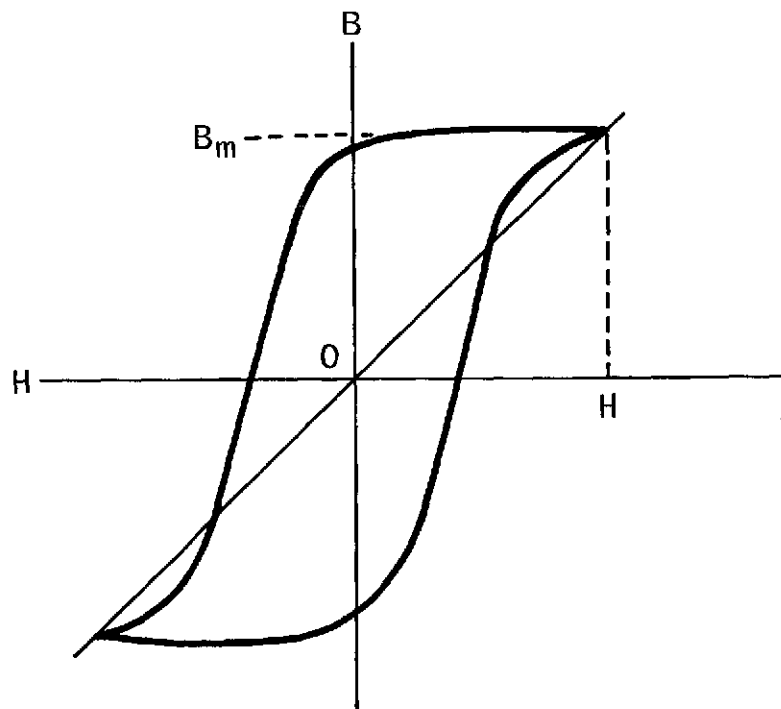

Fig. 58. Hysteresis Loop

Eight coils were wound to show different stacking methods and their effect on relative air gap.

Stacking method: 1 x 1
 5 x 5
 15 x 15
 32 x 32
 BUTT
 BUTT 25 μ m Kraft
 BUTT 50 μ m Kraft
 $\frac{1}{2}$ 1 x 1 & $\frac{1}{2}$ BUTT

Figures 59 through 66 show how the stacking method can influence the permeability. The lamination used and test condition:

Size	E1-375
Material	Permalloy 80
Thickness	0.006
Area	0.91 cm ²
Flux density	0.1T/cm
lm	7.3 cm
Turns	70
Frequency	2.4 kHz

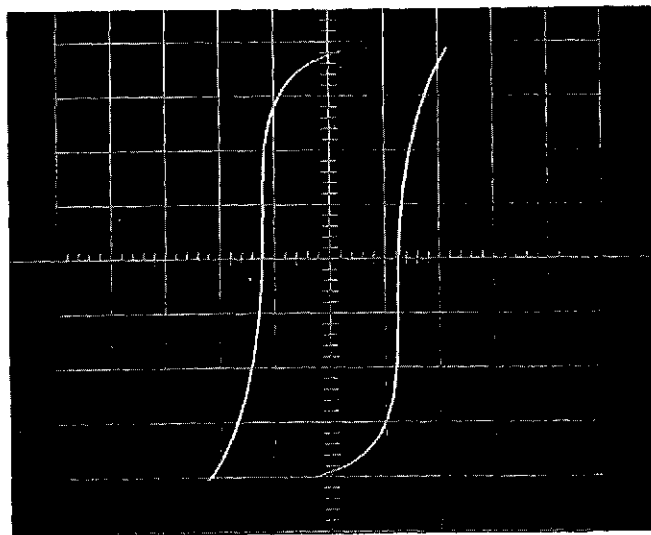

10 ma/cm horiz.
Stack 1 x 1

Fig. 59

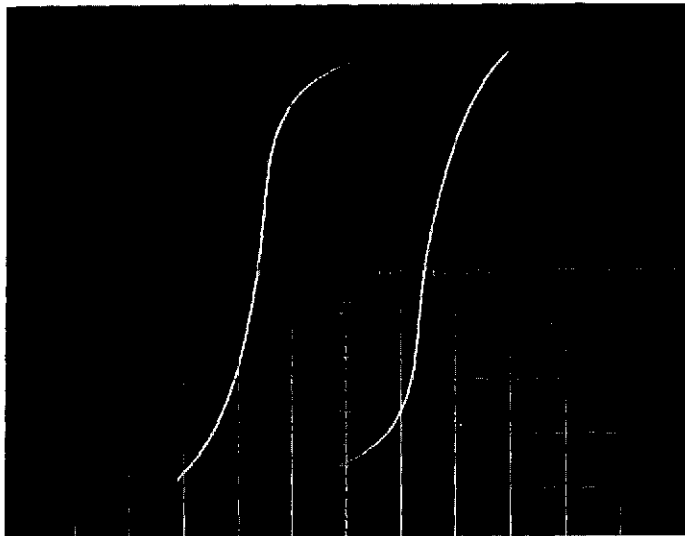

Fig. 60

10 ma/cm horiz
Stack 5 x 5

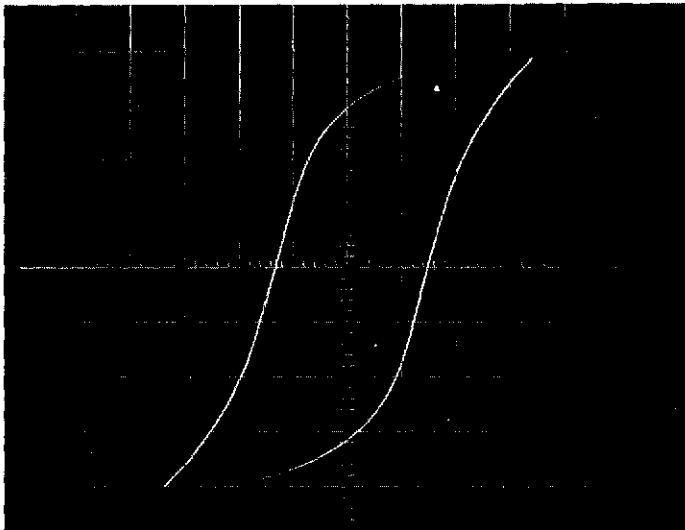

Fig. 61

20 ma/cm horiz
Stack 15 x 15

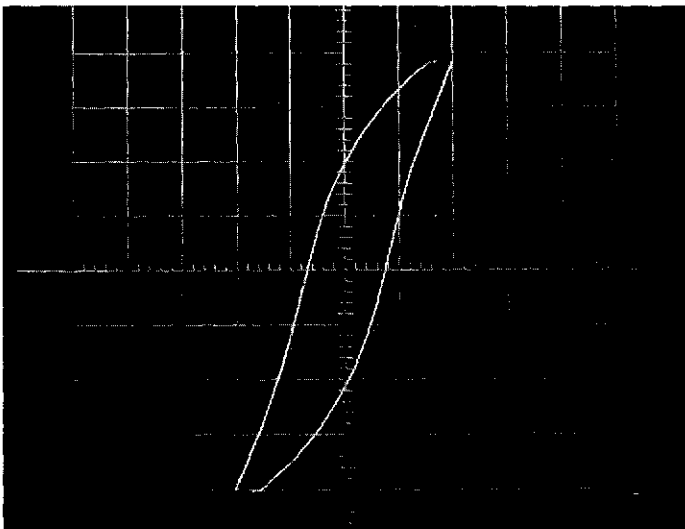

Fig. 62

50 ma/cm horiz
Stack 32 x 32

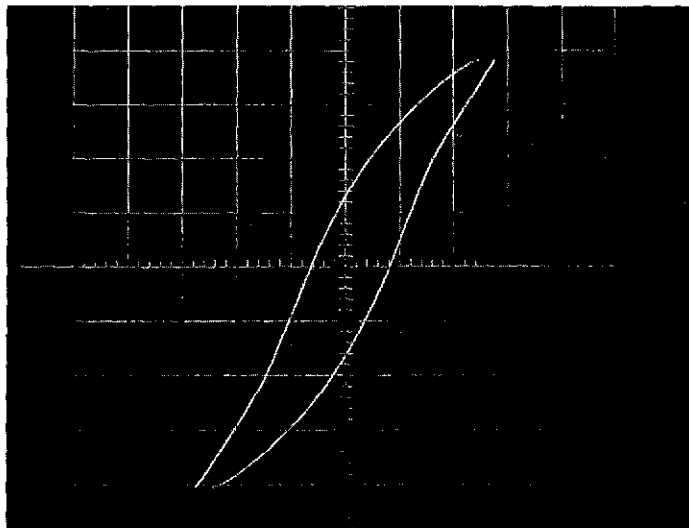

Fig. 63

50 ma/cm horiz
Butt Stack

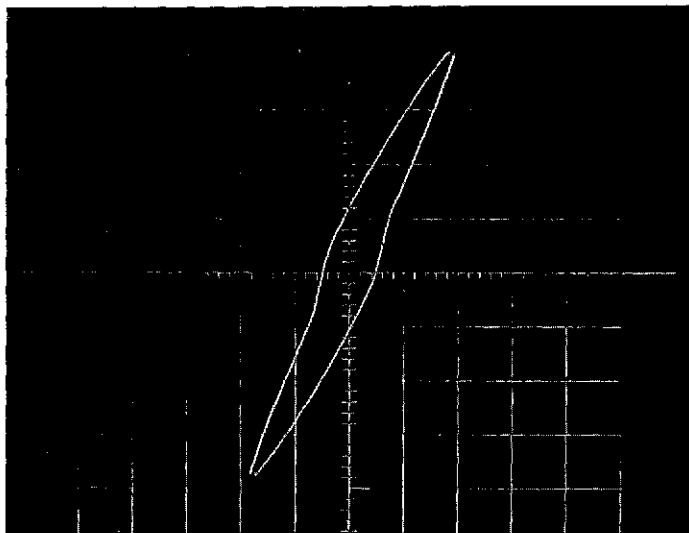

Fig. 64

200 ma/cm horiz
Butt Stack
25 μm gap

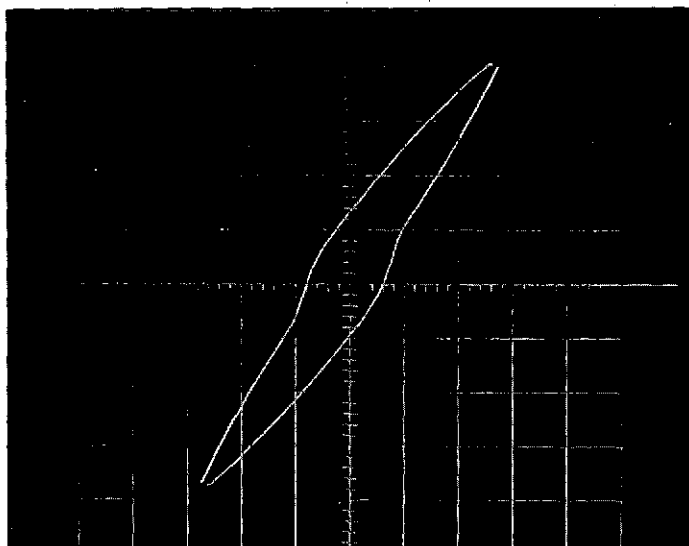
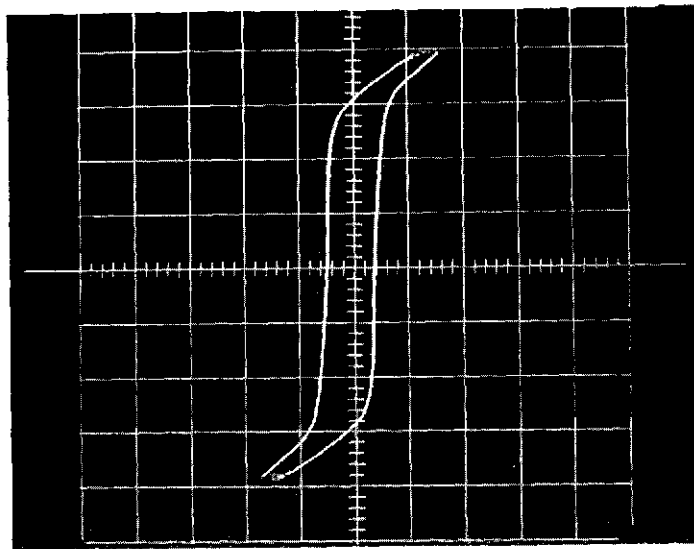

Fig. 65

200 ma/cm horiz
Butt Stack
50 μm gap



50 ma/cm
 Stack
 $\frac{1}{2}$ 1 x 1 & $\frac{1}{2}$ BUTT

Fig. 66

XV. ENGINEERING AIDS

Figures 67, 68, 69 and Table 42 have been inserted for use as engineering aids. The nomograph shown in Figure 67 is for Inductance, Capacitance, and Reactance. Figure 68 can be used to compute the mean turn length and its derivation. Figure 69 compares core loss of four different magnetic materials. These curves show core loss as a function of flux density and frequency. Table 42 is a list of the AIEE preferred tape wound toroidal cores tabulated with metric dimensions.

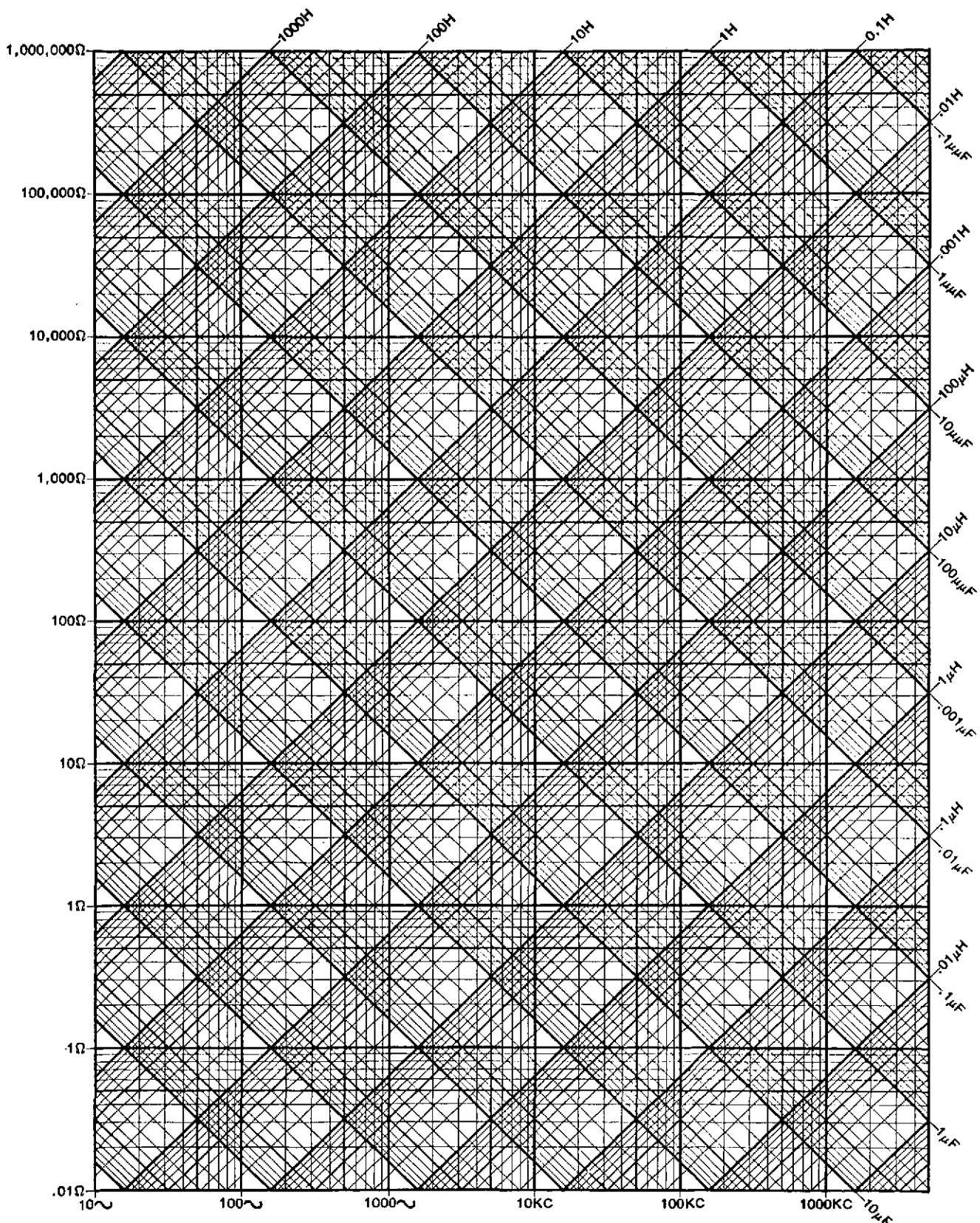
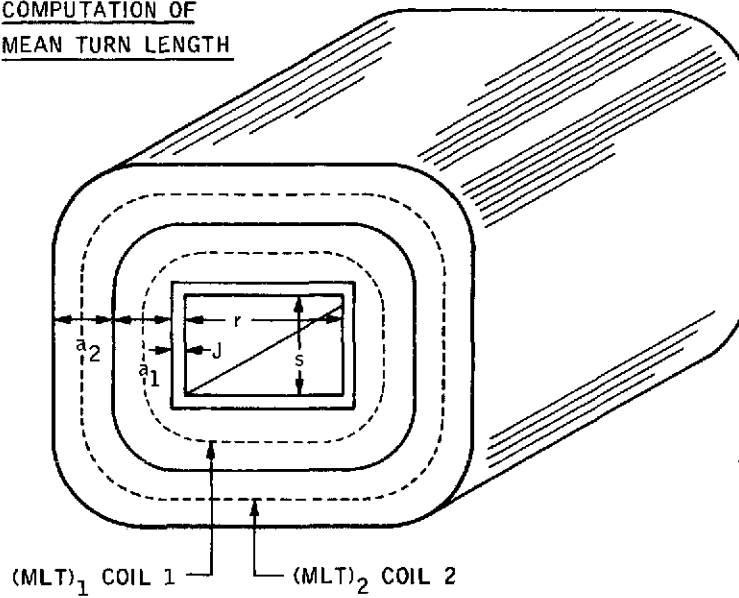

Fig. 67. Nomograph for Inductance, Capacitance, and Reactance

COMPUTATION OF
MEAN TURN LENGTH



$$(MLT)_1 = 2(r+2J) + 2(s+2J) + \pi a_1$$

$$(MLT)_2 = 2(r+2J) + 2(s+2J) + \pi(2a_1+a_2)$$

OR

$$(MLT)_2 = (MLT)_1 + (a_1+a_2+2c)$$

OR

$$(MLT)_n = 2(r+2J) + 2(s+2J) + \pi [2(a_1+a_2+\dots+a_{n-1}) + a_n]$$

WHERE:

a_1 = BUILD OF WINDING #1

a_2 = BUILD OF WINDING #2

a_n = BUILD OF WINDING #n

c = THICKNESS OF INSULATION BETWEEN a_1 & a_2

Fig. 68. Computation of Mean Turn Length

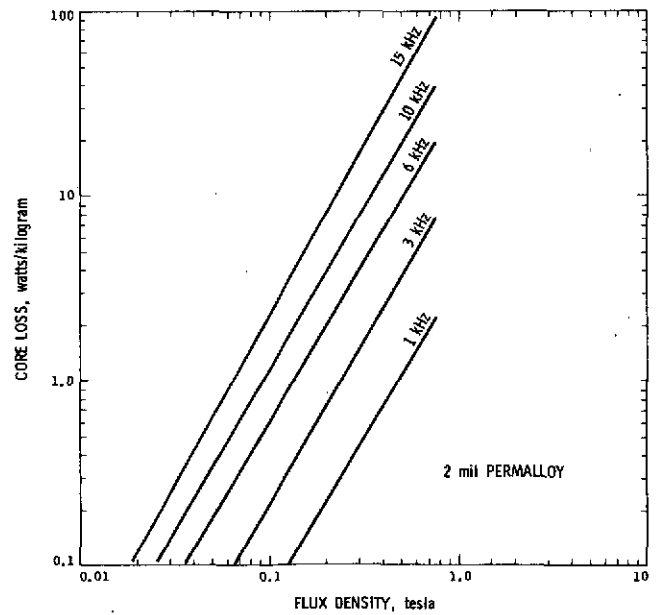
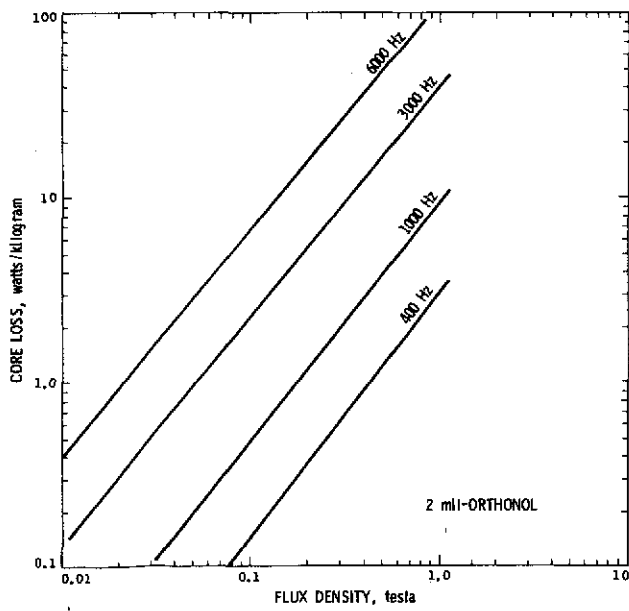
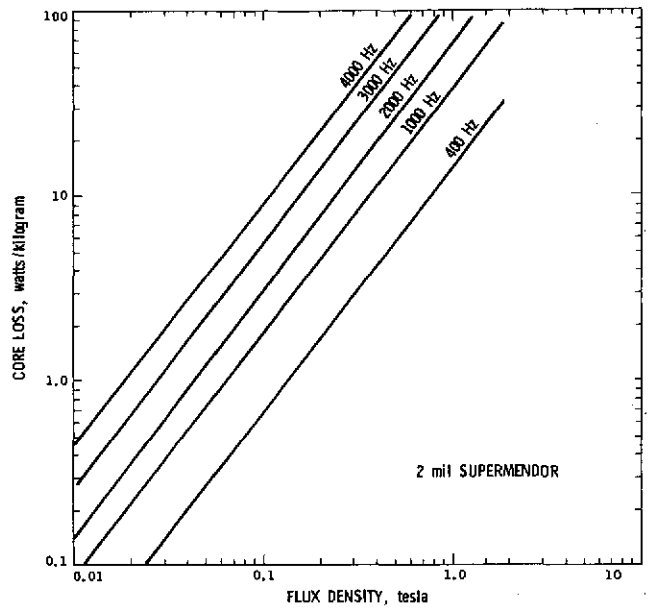
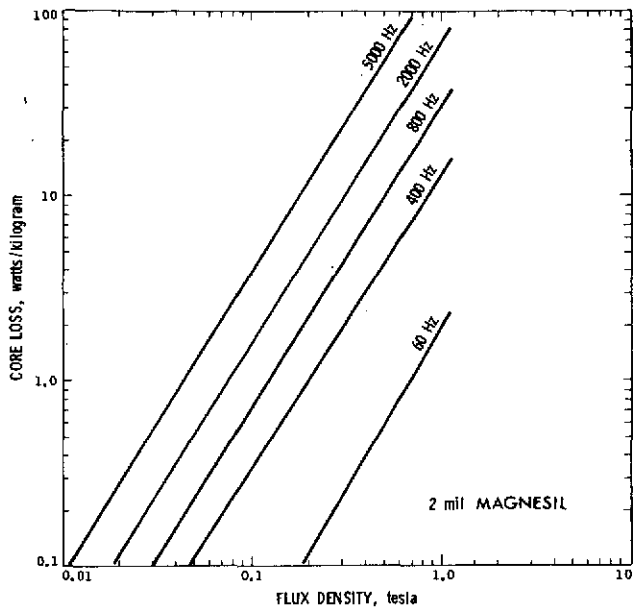

Fig. 69. Silicone, Cobalt, and Nickel Iron Core Loss Curves

Table 42. A.I.E.E. - Preferred Tape Wound Toroidal Cores

Mag Inc	Arnold	(1) Ac(cm ²)	Wa(cm ²) ₁	(2) ID(cm)	OD(cm)	Height (cm)	lm(cm)	Core wt (grams)	Ac x Wa(cm ⁴)
52056	8T8043	0.043	0.877	1.057	1.801	0.643	4.49	1.67	0.0377
52000	8T5340	0.086	0.794	1.006	2.169	0.643	4.99	3.73	0.0682
52076	8T5958	0.193	1.38	1.323	2.804	0.803	6.48	10.9	0.266
52007	8T5651	0.257	1.38	1.323	2.804	0.960	6.19	14.5	0.355
52002	8T5515	0.086	1.51	1.387	2.550	0.643	6.98	4.62	0.129
52061	8T5502	0.171	2.11	1.641	2.804	0.960	7.48	10.4	0.361
52106	8T5504	0.193	2.11	1.641	3.122	0.803	8.98	12.6	0.407
52011	8T4168	0.086	4.07	2.276	3.439	0.643	8.98	6.71	0.350
52004	8T7699	0.171	4.07	2.276	3.439	0.960	9.43	13.4	0.696
52029	8T4635	0.257	4.16	2.301	3.731	0.973	9.97	21.2	1.069
52032	8T5800	0.343	4.07	2.276	4.074	0.973	9.97	29.8	1.396
52026	8T5233	0.514	4.07	2.276	4.074	1.290	9.97	44.7	2.092
52038	8T6847	0.686	4.07	2.276	4.074	1.608	11.96	59.6	2.79
52030	8T5387	0.343	6.65	2.911	4.709	0.973	11.96	35.8	2.28
52035	8T7441	0.686	6.65	2.911	4.709	1.608	11.96	65.6	4.56
52425	8T5772	0.771	6.65	2.911	5.344	1.290	12.96	87.2	5.13
52001	8T5320	1.371	9.45	3.470	6.690	1.679	15.95	191	12.95
52018	8T4179	0.257	11.7	3.863	5.344	0.973	14.46	32.4	3.00
52017	8T4178	0.686	17.6	4.740	6.690	1.679	17.95	107	12.07
52103	8T6110	1.371	17.6	4.740	7.960	1.679	19.94	238	24.12
52022	8T8027	2.742	17.6	4.740	7.960	2.949	19.94	477	48.25
52031	8T4180	0.686	28.4	6.010	7.960	1.679	21.93	131	19.48
52128	8T6100	1.371	28.4	6.010	9.230	1.679	23.93	286	38.93
52042	8T5468	2.742	28.4	6.010	9.230	2.949	23.93	572	77.87
52100	8T5690	5.142	28.4	6.010	9.865	4.219	24.93	1117	146.03
52081	8T5737	5.142	49.2	7.915	11.770	4.219	30.91	1386	253
52427	8T9259	7.198	49.2	7.915	13.040	4.219	32.90	2065	354
52112	8T5611	6.855	75.7	9.820	13.675	5.489	36.89	2205	519
52426	8T9260	10.968	75.7	9.820	15.580	5.489	39.88	3814	830

(1) Cross-sectional area calculated for 2 mil (0.002 in.) material

(2) Dimensions listed are sizes of aluminum boxed cores (not coated)

REFERENCES

1. Magnetic Wire Datalator. REA Magnetic Wire Co., Inc., Fort Wayne, Ind., 1958.
2. Molypermalloy Powder Cores. Catalog MPP-303S, Magnetic, Inc., Butler, Pa.
3. Design Manual Featuring Tape Wound Cores. Design Manual TWC-300, Magnetic, Inc., Butler, Pa., 1962.
4. MPP Cores. Catalog PC-104E, Arnold Engineering, Marengo, Ill., 1972.
5. Blume, L. F., Transformer Engineering. John Wiley & Sons, Inc., New York, N. Y., 1938.
6. Lee, R., Electronic Transformers and Circuits. Second Edition. John Wiley & Sons, New York, N. Y., 1958.