

**NASA TECHNICAL
MEMORANDUM**

**NASA TM X-71994
COPY NO.**

NASA TM X- 71994

**A STUDY OF SUBSONIC TRANSPORT AIRCRAFT CONFIGURATIONS
USING HYDROGEN (H₂) AND METHANE (CH₄) AS FUEL**

N74-32432

Unclass
47925

G3/02

BY

Daniel B. Snow, LaRC

Blake D. Avery, LTV/HTC

Lawrence A. Bodin, LTV/HTC

Paul Baldasare, LTV/HTC

G. Fredrick Washburn, LTV/HTC



August 1, 1974

This informal documentation medium is used to provide accelerated or special release of technical information to selected users. The contents may not meet NASA formal editing and publication standards, may be revised, or may be incorporated in another publication.

**NATIONAL AERONAUTICS AND SPACE ADMINISTRATION
LANGLEY RESEARCH CENTER, HAMPTON, VIRGINIA 23665**

(NASA-TM-X-71994) A STUDY OF SUBSONIC
TRANSPORT AIRCRAFT CONFIGURATIONS USING
HYDROGEN (H₂) AND METHANE (CH₄) AS FUEL
(NASA) 32 P HC \$3.25 CSCL 01C

1. Report No. NASA TM X-71994		2. Government Accession No.		3. Recipient's Catalog No.	
4. Title and Subtitle A Study of Subsonic Transport Aircraft Configurations Using Hydrogen (H ₂) and Methane (CH ₄) as Fuel				5. Report Date August 1, 1974	
				6. Performing Organization Code	
7. Author(s) Daniel B. Snow, LaRC; Blake D. Avery, LTV/HTC; Lawrence A. Bodin, LTV; Paul Baldasare, LTV/HTC; G. Fredrick Washburn, LTV/HTC				8. Performing Organization Report No.	
				10. Work Unit No.	
9. Performing Organization Name and Address NASA Langley Research Center Hampton, Virginia 23665				11. Contract or Grant No.	
				13. Type of Report and Period Covered TMX	
12. Sponsoring Agency Name and Address NASA				14. Sponsoring Agency Code	
15. Supplementary Notes Special technical information release, not planned for formal NASA publication					
16. Abstract With questionable future oil supplies and increasing energy requirements as an impetus, this study undertakes to determine the acceptability of alternate fuels for future commercial transport aircraft. Using both liquid hydrogen and methane, several aircraft configurations are developed and energy consumption, aircraft weights, range and payload are determined and compared to a conventional Boeing 747-100 aircraft. The results show that liquid hydrogen can be used to reduce aircraft energy consumption and that methane offers no advantage over JP or hydrogen fuel.					
17. Key Words (Suggested by Author(s)) (STAR category underlined) <u>Aircraft</u> , Hydrogen fuel Methane fuel			18. Distribution Statement Unclassified - Unlimited		
19. Security Classif. (of this report) Unclassified		20. Security Classif. (of this page) Unclassified		21. No. of Pages 30	22. Price* \$3.25

A STUDY OF SUBSONIC TRANSPORT AIRCRAFT CONFIGURATIONS
USING HYDROGEN (H₂) AND METHANE (CH₄) AS FUEL

by

Daniel B. Snow, LaRC

Blake D. Avery, LTV/HTC

Lawrence A. Bodin, LTV/HTC

Paul Baldasare, LTV/HTC

G. Fredrick Washburn, LTV/HTC

LANGLEY RESEARCH CENTER

August 1, 1974

INTRODUCTION

In the spring of 1973 Langley Research Center began an Energy Trends/ Aircraft Fuels (ET/AF) Study to assess the impact on aircraft design and energy consumption when fuels other than JP are utilized. Both hydrogen and methane fuel were investigated and the resulting aircraft were compared to a baseline JP fueled aircraft--the Boeing 747-100. While the data in this report, i.e., weights, drag polars, mission analysis results and configuration drawings, should provide a strong base for follow-on effort in this field, more work is required before a final configuration selection can be made. Some follow-on effort is already being pursued both in-house and on contract with the Lockheed Aircraft Corporation.

Although some complementary work was being conducted simultaneously at LaRC and other NASA centers, this document will deal entirely with the subsonic aircraft studies which were directed by LaRC and heavily supported by HTC, LTV Aerospace Corporation.

SYMBOLS

AR	Wing Aspect Ratio
ATA	Air Transport Association
BTU/PM	British Thermal Units Per Passenger Nautical Mile
C_D	Total Drag Coefficient
C_{Dc}	Compressibility Drag Coefficient
C_{DF}	Form Drag Coefficient
C_{Df}	Skin Friction Drag Coefficient
C_{DI}	Interference Drag Coefficient
C_{Di}	Induced Drag Coefficient (Coefficient of Drag due to Lift $\frac{C_L^2}{\pi AR e}$)
C_{Dp}	Minimum Parasite Drag Coefficient
C_{Dw}	Wing Camber Drag Coefficient
C_{DXT}	Increase in Friction Drag Coefficient over Baseline Value
CH ₄	Methane
d	Fuselage Diameter, ft.
ESF	Engine Scale Factor
ET/AF	Energy Trends/Aircraft Fuels (study)
ft ²	Square Feet
H ₂	Hydrogen
HFO	Hydrogen in Fuselage, Overhead
HFO-368	HFO with 368 passengers
HFO-480	HFO with 480 passengers
HPP	Hydrogen Fuel, Passengers in Pods

HPP-364	HPP with 364 passengers
HPP-438	HPP with 438 passengers
HPT	Hydrogen in Pods on Tips of Wing
HPU	Hydrogen in Pods Under the Wings
HSAD	High Speed Aircraft Division
HTC	Hampton Technical Center
JP-4	Jet Propellant Similar to Kerosene
l	Fuselage Length, in.
LaRC	Langley Research Center
lb	Pounds
lb/ft ²	Pounds per Square Foot
l/d	Fuselage Length to Diameter Ratio
LH ₂	Liquid Hydrogen
LCH ₄	Liquid Methane
MAC	Mean Aerodynamic Chord, in.
MFO	Methane in Fuselage, Over
MFU	Methane in Fuselage, Under
MFU-368	MFU with 368 passengers
MFU-416	MFU with 416 passengers
MPU	Methane in Pods Under the wings
NASA	National Aeronautics and Space Administration
n.m.	Nautical Miles
OWE	Operating Weight Empty, lb.
P/L	Payload, lb.
P&WA	Pratt & Whitney Aircraft
S _{GROSS}	Gross Wing Area, ft ²

S_{REF}	Reference Wing Area, ft^2
TOGW	Takeoff Gross Weight, lb.
t/c	Wing Thickness to Chord Ratio
T/W	Thrust to Weight Ratio
W/S	Wing Loading, lb/ft^2
$\Lambda_{C/4}$	Quarter Chord Sweep Angle, degrees
λ	Wing Taper Ratio

STUDY GUIDELINES AND CONSTRAINTS

GENERAL

Before aircraft configuration studies were begun, several guidelines were established; others were incorporated as the study progressed and the need to establish boundaries became obvious. Below are listed the important guidelines.

Range	5000 nautical miles
Payload	368 passengers plus baggage (77,000 lb.)
Cruise Mach Number	0.82
Wing loading	Approximately 125 lb/ft ² for hydrogen, slightly higher for methane
Thrust to Weight Ratio (T/W)	0.25 - 0.35
Fuel Reserves	1967 ATA International requirements
Engine	P&WA JT9D-7 scaled to required thrust
Fuselage Fineness Ratio (l/d)	9 - 12

FUELS

The major guideline under which this study was conducted was the use of liquid hydrogen (LH₂) and liquid methane (LCH₄) as alternate fuels for passenger and cargo air transports. Some properties of these fuels are shown in Table I.

A significant factor in the design of these aircraft was fuel density. Although hydrogen and methane are more efficient fuels than JP on a weight basis, their low density requires large tankage volume. Another significant characteristic of these fuels is that to maintain them in a liquid state and to prevent enormous fuel losses from boil-off, fuel tanks must be pressurized. Consequently, tank design became a driving force in the aircraft configurations using either of these fuels.

TANK CONCEPTS

Three categories of fuel containment were considered in this study:

- (1) Fuel contained within the wing. (2) Fuel in pods on the wing, and
- (3) Fuel in the fuselage (see figure 1). Within each category was the option of integral or non-integral tanks.

ANALYSIS PROCEDURE

Drawing upon experience gained in earlier Advanced Transport Technology (ATT) Studies, the LaRC/LTV team used a straightforward but comprehensive approach to the integrated design effort. Basically, the following steps were used:

1. Configurations

a. general arrangements - A layout of the desired aircraft was made with fuel in the fuselage or fuel in wing pods, double-deck or single-deck, high wing or low wing, four engines or three, etc.

b. passenger/fuel matching - The desired number of passengers was selected which established payload weight. Passenger accommodations were then added to the layout. An estimation method provided an approximate fuel requirement for a selected range and the appropriate tank volume was then added to the aircraft layout. If the aircraft size and fuel volume were not compatible at this point, adjustments were made by changing the aircraft size to accommodate both passengers and fuel. This iteration was continued as each additional step was incorporated in the configuration studies.

c. dimensions - When the above steps were compatible, dimensions were taken from the scaled drawings to provide wetted areas, slenderness ratio, component sizes, volumes, etc. This data was used as input to determine aerodynamic and weight characteristics.

2. Aerodynamic Characteristics - LRC aerodynamicists provided the basic drag data (Table II) for an aircraft approximately the same as the JP-fueled Boeing 747 aircraft used as a baseline design in this study. The data included skin friction drag coefficient ($C_{D,f}$), form drag

coefficient ($C_{D,F}$) [combined and used as minimum parasite drag coefficient ($C_{D,p \text{ min}}$)] and interference drag coefficient ($C_{D,I}$). To this data was added an estimation of the coefficient of drag due to wing camber ($C_{D,W}$). The coefficients of drag due to lift ($C_{D,l}$), and compressibility drag ($C_{D,c}$), i.e. drag rise due to Mach number, were then calculated and added to previously determined numbers to yield the total drag coefficient (C_D). No trim drag was considered. This coefficient and other information was used as input data into a Mission Analysis Program.

3. Weights Analysis - A comprehensive statistical weights program developed by LTV was used to produce a systems' weight breakdown to the level shown in Table III. Dimensional data taken primarily from the configurations effort was used as input. These input data categories are listed below:

- ° Wing geometry
- ° Fuselage geometry
- ° Fuel tank geometry
- ° Fuel tank locations
- ° Mission fuel
- ° Payload

Some weight components were assumed to be invariant for ease of calculation on this preliminary effort. Components in this category are listed below:

- ° Engines, nacelles, thrust reversers
- ° Landing gear system
- ° Empennage
- ° Some systems and equipment such as radar, computers and other electronics

Since most of this study was conducted using a Boeing 747-100 aircraft design as baseline, values for that aircraft were used for landing gear weight and tail volume coefficient. Also, the Boeing 747 engine (JT9D-7) weight was used as a constant although thrust was scaled to match the mission. The results from the weights analysis were subsequently used as input into the Mission Analysis Program.

4. Mission Analysis - A Mission Analysis Program (PAB2011), developed by NASA-Langley, HSAD, was used to evaluate payload/range requirements. The program includes take-off, climb, cruise and descent segments of a mission. Cruise is determined by a single step Brequet equation. Significant inputs to the program are listed below:

- LH₂ or LCH₄ fueled engine data which includes thrust and fuel flow vs. Mach number and altitude
- Base pressure table
- Delta drag coefficient, which is the increment of drag coefficient between baseline configuration and analyzed configuration
- Lift coefficient table
- Wing reference area
- Weights (TOGW, OWE, and P/L)
- Cruise Mach number
- Engine scale factor
- Input range

Air Transport Association (ATA) International rules were used for mission and reserves calculations. A flight profile schematic showing the ATA requirements is given in figure 2.

A "rubber engine" computer deck containing Pratt & Whitney Aircraft JT9D-7 engine performance data was used to represent the basic power plant for this study. Fuel flows were adjusted based on the Lower Heating Values (LHV) of hydrogen and methane. A basic installed thrust of 40,900 pounds was modified by use of an engine scale factor (ESF) to permit climb and cruise at the proper Mach number/altitude combination for various aircraft configurations.

Results from the mission analysis program are shown on the configuration sketches, figures 3 through 9 and a summary of aircraft weights is given in Table IV.

STUDY RESULTS

Tank and Fuel

1. Fuel within the wings - Integral tanks in the wing are not practical for hydrogen or methane fueled aircraft because of the pressure that is required to maintain cryogenic fuels in a liquid state. A pressure vessel with nearly flat sides (upper and lower wing surfaces) is excessively heavy. A brief study of non-integral wing tanks indicated insufficient space available for the large volume of fuel required and excessively high tankage weight to fuel volume ratio.

2. Fuel in pods on the wing - Safety is a prime consideration in the design of any aircraft, particularly one with fuel as volatile as hydrogen. Wing pods offer the advantage, in terms of safety, of separation of passengers and cargo from the fuel. In addition, inspection, maintenance and normal ground operations such as fueling support the use of remotely located fuel tanks.

3. Fuel in the fuselage - This concept offers many variations in tank configuration: spherical, elliptical, cylindrical and lobed tanks, located overhead, fore and aft, and in the center of the fuselage. Only a few of these, however, were exercised because of available time. Full fuselage diameter cylindrical tanks, while they may prove to be the most efficient concepts, were eliminated in this study because of possible regulations relating to pilot access to the passenger compartment. Such configurations have an obvious advantage because of the high ratio of fuel volume to tank weight and therefore will be investigated in future efforts. The detailed analysis of fuselage tanks in this study considered that the tanks were located either above or below the passenger compartment. One

exception to this located the passengers in wing pods thereby permitting the use of the entire fuselage for fuel storage.

Hydrogen Configurations

1. Hydrogen in the Fuselage, Overhead - HFO

The HFO configuration, figure 3, had the least weight of fuel, the lowest drag count and the smallest engines of all hydrogen configurations studied. Take-Off Gross Weight (TOGW), however, was not the least. The compounded problem of non-integral and unconventionally shaped tanks was a major reason for the weight being as high as it was---592,932 pounds. The tank shape was selected in an attempt to utilize as much of the "D" cross-section in the top of the fuselage as possible. The HFO aircraft incorporates a single passenger deck with a 15/85 first class/tourist mix in a twenty-four (24) foot wide fuselage with six (6) abreast seating in the first-class section and ten (10) abreast seating in the tourist section. The large volume of liquid hydrogen needed for a 5000 n.m. range in turn provided a large passenger space for a configuration of this type. In fact, the first layout for 368 passengers (HFO-368) yielded excess cabin space. By modifying the seating arrangement and seat pitch it was possible to provide space for 480 passengers in the fuselage (configuration HFO-480). It was necessary, however, to increase the fuel capacity by 5000 pounds to maintain the 5000 n.m. range so the fuel tanks were enlarged slightly to accommodate the added fuel. The energy consumption, 2047 BTU/PM, for the HFO-480 was the lowest of all aircraft studied under this effort.

2. Hydrogen in Pods on Tips of wings - HPT

This configuration is shown in figure 4. Significant features of this 368 passenger aircraft include wing mounted fuel pods, a T-tail and

location of the engines on the aft fuselage. The large 124.3 feet long and 16 feet in diameter cylindrical pods on the wing tips contain over 115,000 pounds of LH_2 . There are clear advantages and disadvantages with this design. Separation of fuel and passengers provides superior safety aspects yet imposes a severe drag penalty which requires larger engines and more fuel than the HFO aircraft. This results in a much greater energy consumption (2726 BTU/PM) than the HFO-480 and a slightly greater consumption rate than the HFO-368. By comparison of the HPT performance data in figure 4 and Boeing 747-100 data in Table V it can be seen that the take-off gross weight of the HPT is 125,506 pounds less than the JP fueled Boeing 747-100 which has the same payload/range capability.

3. Hydrogen in Pods Under the wings - HPU

Except for the fuel pods, the HPU (shown in figure 5) and HPT configurations are identical. An intersecting double cylinder tank system is used to reduce tank depth and permit ground clearance with the under-the-wing installation. The small difference in wetted area and resulting difference in drag level, engine thrust and energy consumption between the HPU and HPT were considered to be minor and were therefore neglected for this analysis.

4. Hydrogen fuel, Passengers in Pods on the wing - HPP

Figure 6 shows the configuration and data for two hydrogen fueled air transports with passengers in wing pods and fuel in non-integral full fuselage diameter tanks (only in the wing box area are tank sizes reduced). One set of data is for 364 passengers seated five (5) abreast (HPP-364) and the other set of data is for 438 passengers seated six (6) abreast (HPP-438). These aircraft unlike the other hydrogen fueled concepts, have

a high mounted wing with twin engine nacelles under the wing. At 437,540 lb. and 448,389 lb. for the HPP-364 and HPP-438 respectively, the operating weight empty (OWE), is greater for these two configurations than for the other hydrogen fueled aircraft considered in this study. Energy consumption for these two aircraft, 3003 BTU/PM (HPP-364) and 2573 BTU/PM (HPP-438), was also quite high. For these and other reasons, such as excessive motion and loads anticipated in the passenger cabins during aircraft maneuvers, these configurations will probably receive little additional attention.

Methane Configurations

1. Methane in Fuselage, Under - MFU

In this configuration, shown in figure 7, methane fuel was contained in the lower section of the fuselage under the passenger compartment. The tank shapes were the same as for hydrogen but the tank size was much smaller. The MFU design is slightly shorter in overall aircraft length than a Boeing 747. It, like the HFO, was configured for 368 passengers (MFU-368) and 5000 n.m. range. It was also rearranged for additional passengers, 416 total (MFU-416), at the same range. This aircraft has an OWE which is only slightly greater (approximately 7000 lb.) than the HFO but with the addition of fuel the TOGW is much greater---772,063 lb. compared to 592,932 lb.---a 179,131 lb. difference. As a result, both engine thrust and BTU/PM are large relative to the HFO. This design does provide a large cargo space fore and aft of the fuel tanks that was not available in the HFO design.

2. Methane in Fuselage, Over - MFO

The only difference in the exterior of the MFO, figure 8, and MFU configurations is the bubble beneath the passenger compartment of the MFO to provide for wing box carry-through structure. This results in a small increase in drag for the MFO, thereby requiring a slightly higher cruise altitude than for the MFU configuration.

The fuel and passenger arrangement for the MFO configuration provides excess space in the upper fuselage section. A modification of this concept utilizing this excess space for additional fuel for longer range or additional passengers appears to be a more practical concept. Such a configuration should perform comparable to the MFU-416.

3. Methane in Pods Under the Wings - MPU

To facilitate safety and provide cylindrical tanks for pressurized cryogenic methane, wing pod tanks were incorporated on the MPU design shown in figure 9. At 113.7 feet long and 11 feet in diameter, the wing pods are much smaller than the HPT tanks and appear to be an acceptable size in proportion to the Boeing 747 size fuselage. TOGW of this aircraft is 43,500 lb. heavier than the other methane designs, and 16,000 pounds more fuel are required to maintain Mach 0.82 and a 5000 n.m. range. The advantages of this aircraft, compared to other methane aircraft, are the same as the HPT and HPU aircraft--safety and ease of tank inspection and maintenance.

CONCLUSIONS

Because this study did not address the problem of economics directly, only from the standpoint of fuel utilization, no single aircraft configuration selection is made. There were, however, several conclusions derived which will aid in this selection. They are listed below:

1. The economics of both flight operations (aircraft performance) and ground operations (maintenance) combined with safety have a strong influence on the configuration of an alternate-fuel aircraft. In this respect configurations with wing pod fuel tanks offer advantages in ground operations and safety, and configurations with fuel in the fuselage offer advantages in performance.

2. If the aircraft are large, approximately 400 passengers or more, LH_2 fueled aircraft offers superior performance characteristics (BTU/PM) as compared to JP fueled aircraft. The JP fueled aircraft, in turn, offers superior performance when compared to the CH_4 fueled aircraft.

3. Methane fuel, in addition to having the disadvantages of a cryogen, does not possess the advantages of high heat content and low density provided by hydrogen fuel.

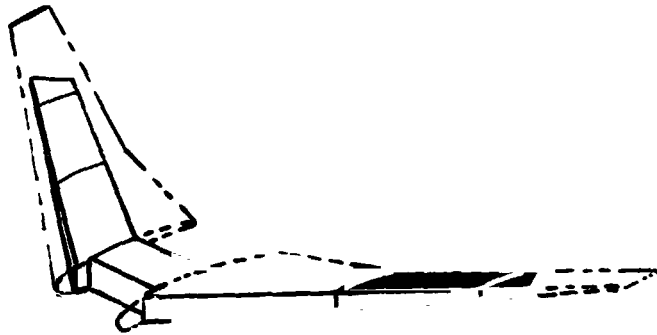

FUEL CONTAINED WITHIN WING BOX
(1)

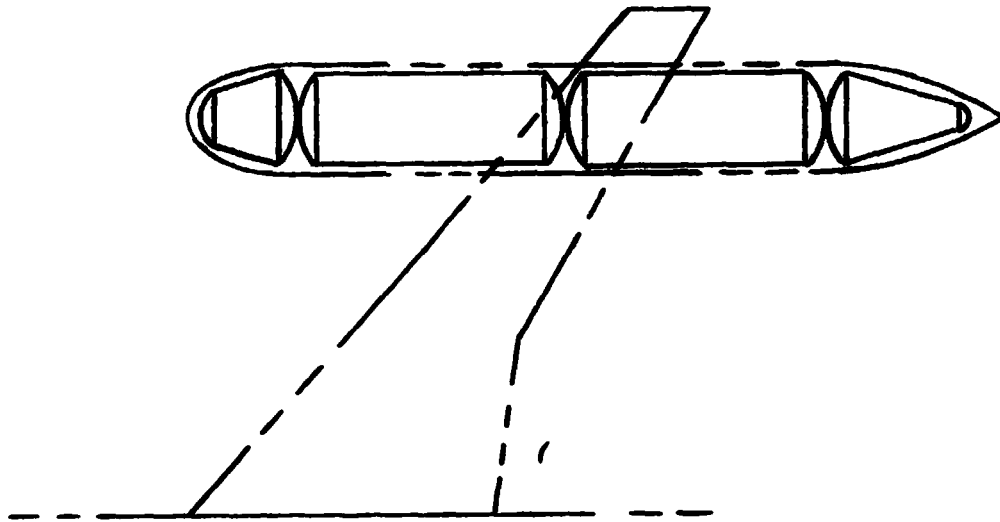

FUEL IN PODS ON WING
(2)

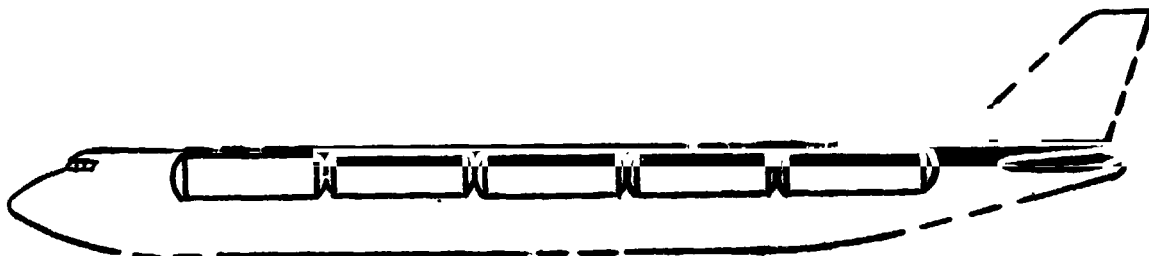

FUEL IN THE FUSELAGE
(3)

FIGURE 1

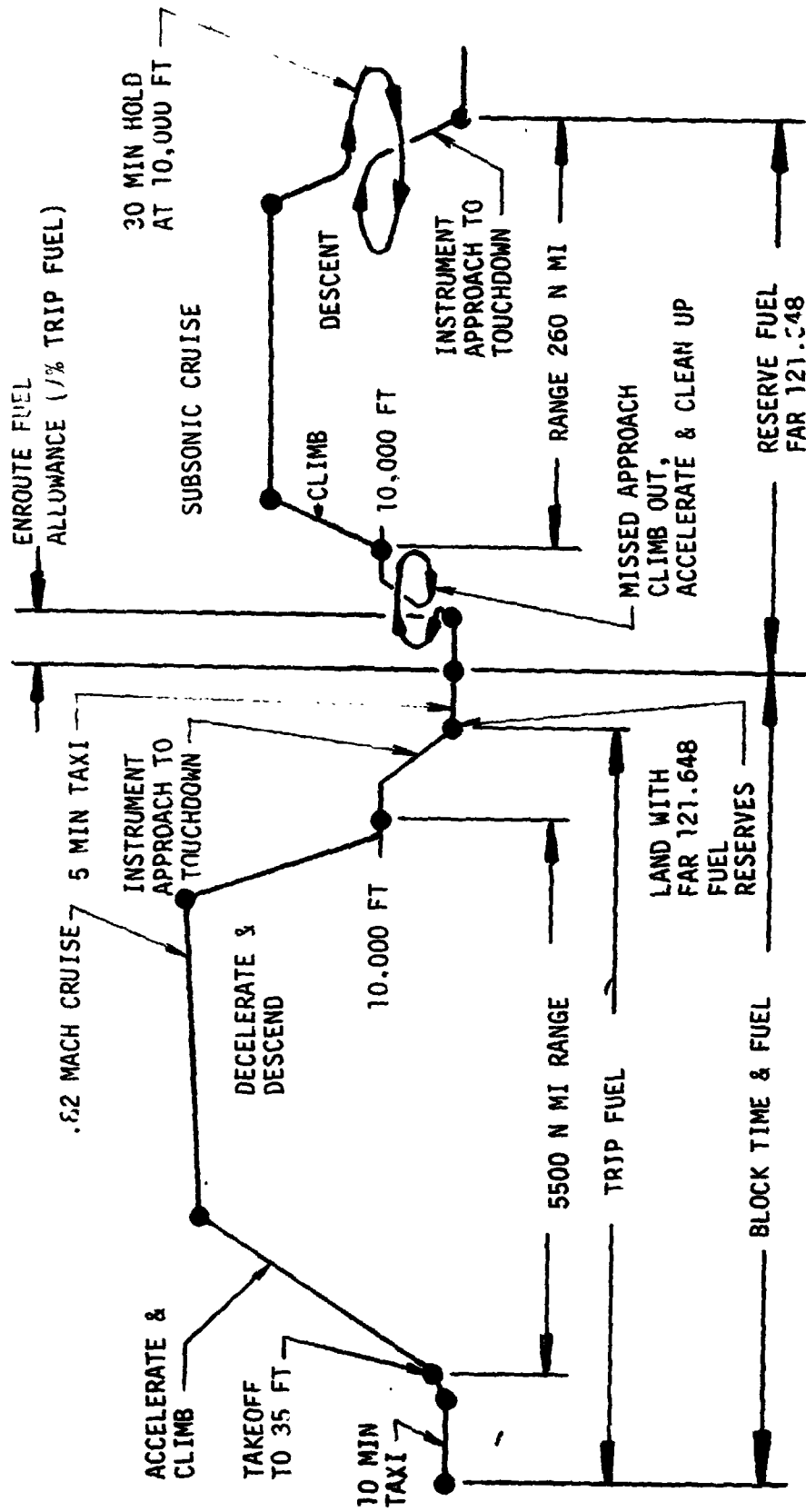

MISSION PROFILE

FIGURE 2

PERFORMANCE DATA - 368 PASSENGERS

OWE	406,932 LBS.	FUSELAGE LENGTH	270.0 FT.
PAYLOAD	77,000 LBS.	FUSELAGE DEPTH	25.75 FT.
FUEL	107,000 LBS.	FUSELAGE WIDTH	24.00 FT.
TOGW	592,932 LBS.	WING SPAN	165.8 FT.
RANGE	4,978 N. MI. ²	THRUST/WEIGHT	.28
W/S	128 LBS/FT ²	MACH NO.	.82
S _{REF}	3950 FT. ²	THRUST	40,900 LBS/ENGINE
S _{GROSS}	4642 FT. ²	ENERGY REQ'D	2654 BTU/PASS. MI.
ALT. START CR.	30,500 FT.	BURNED FUEL	90,113 LBS.
ALT. END CR.	33,800 FT.		

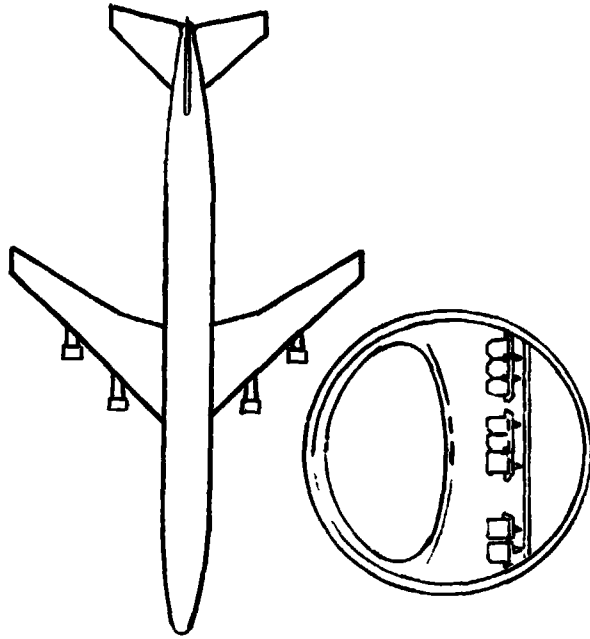

PERFORMANCE DATA - 480 PASSENGERS

OWE	426,127 LBS.	FUSELAGE LENGTH	270.0 FT.
PAYLOAD	100,400 LBS.	FUSELAGE DEPTH	25.75 FT.
FUEL	112,000 LBS.	FUSELAGE WIDTH	24.00 FT.
TOGW	638,527 LBS.	WING SPAN	172.1 FT.
RANGE	4,950 N. MI. ²	THRUST/WEIGHT	.256
W/S	128 LBS/FT ²	MACH NO.	.82
S _{REF}	4270 FT. ²	THRUST	40,900 LBS/ENGINE
S _{GROSS}	5,000 FT. ²	ENERGY REQ'D	2047 BTU/PASS. MI.
ALT. START CR.	29,500 FT.	BURNED FUEL	94,250 LBS
ALT. END CR.	32,700 FT.		



FIGURE 3 HFO

PERFORMANCE DATA - 368 PASSENGERS

OWE	392,439 LBS.	FUSELAGE LENGTH	227.7 FT.
PAYLOAD	77,000 LBS.	FUSELAGE DEPTH	22.3 FT.
FUEL	115,055 LBS.	FUSELAGE WIDTH	21.25 FT.
TOGW	584,494 LBS.	WING SPAN	166.6 FT.
RANGE	4,992 N. MI.	THRUST/WEIGHT	.308
W/S ^{GROSS}	123 LBS/FT ²	MACH NO.	.82
S _{REF}	4041 FT. ²	THRUST	45,000 LBS/ENG.
S _{GROSS}	4746 FT. ²	ENERGY REQ'D	2726 BTU/PASS. MI.
		ALT. START CR.	33,000 FT.
		ALT. END CR.	36,600 FT.
		BURNED FUEL	97,048 LB.

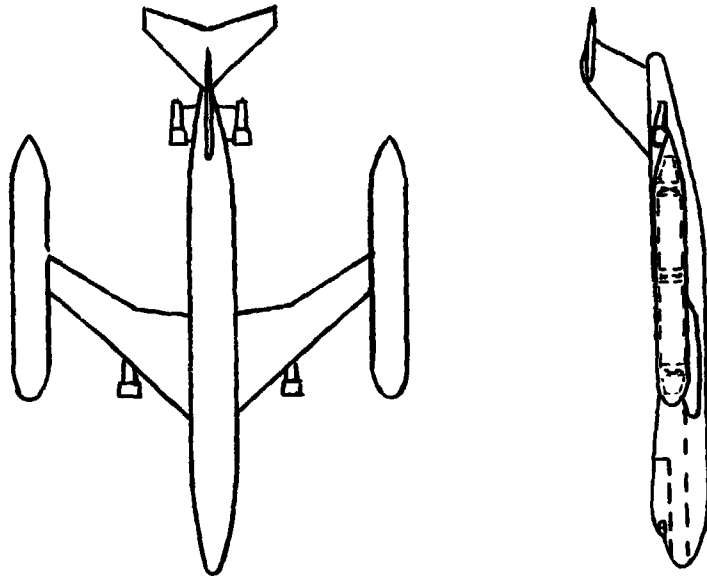
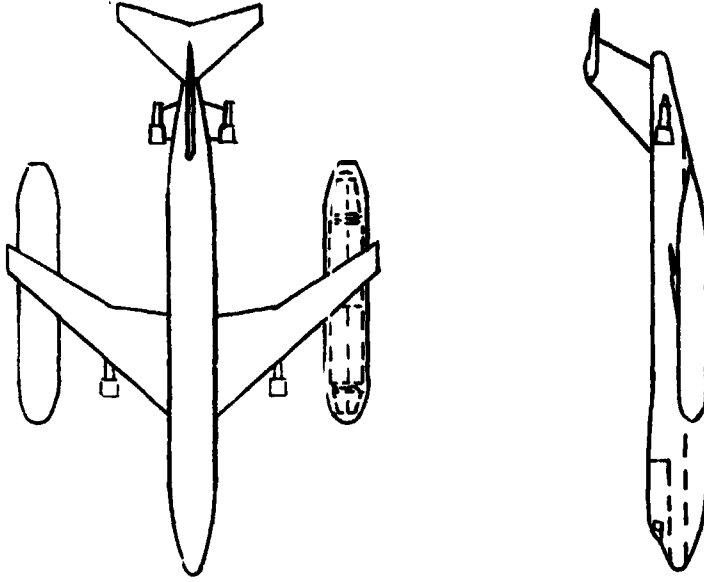

FIGURE 4 HPT



PERFORMANCE DATA - 368 PASSENGERS

OWE	392,439 LBS.	FUSELAGE LENGTH	227.7 FT.
PAYLOAD	77,000 LBS.	FUSELAGE DEPTH	22.3 FT.
FUEL	115,055 LBS.	FUSELAGE WIDTH	21.25 FT.
TOGW	584,494 LBS.	WING SPAN	166.6 FT.
RANGE	4,992 N. MI.	THRUST/WEIGHT	.308
W/S	125 LBS/FT. ²	MACH NO.	0.82
S _{REF}	4041 FT. ²	THRUST	45,000 LBS/ENG
S _{GROSS}	4746 FT. ²	ENERGY REQ'D	2726 BTU/PASS. MI.
		FUELED BURNED	97,048 LBS.
		ALT. START CR.	33,000 FT.
		ALT. END CR.	36,600 FT.

FIGURE 5 HPU

PERFORMANCE DATA - 364 PASSENGER - FIVE ABREAST

OWE	437,540 LBS	FUSELAGE LENGTH	225.2 FT.
PAYLOAD	77,000 LBS	FUSELAGE DEPTH	22.3 FT.
FUEL	117,092 LBS.	FUSELAGE WIDTH	21.25 FT.
TOGW	631,632 LBS.	WING SPAN	173.8 FT.
RANGE	4639 N. MI.	THRUST/WEIGHT	.285
W/S	125 LBS/FT. ²	MACH NO.	.82
SREF	4,338 FT. ²	THRUST	45,000 LBS/ENG.
SGROSS	5,090 FT. ²	ENERGY REQ'D	3003 BTU/PASS. MI.
ALT. START CR.	31,500 FT.	FUEL BURNED	98,263 LBS.
ALT. END CR.	34,800 FT.		

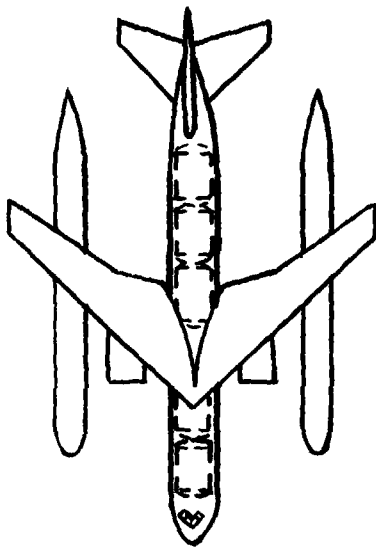

PERFORMANCE DATA - 438 PASSENGER-SIX ABREAST

OWE	448,389 LBS.	FUSELAGE LENGTH	225.2 FT.
PAYLOAD	91,647 LBS	FUSELAGE DEPTH	22.3 FT.
FUEL	117,092 LBS.	FUSELAGE WIDTH	21.25 FT.
TOGW	657,128 LBS.	WING SPAN	176.5 FT.
RANGE	4,483 N. MI.	THRUST/WEIGHT	.29
W/S	125 LBS/FT. ²	MACH NO.	.82
SREF	4,476 FT.	THRUST	47,362 LBS/ENG.
SGROSS	5,257 FT.	ENERGY REQ'D	2,573 BTU/PASS. MI.
ALT. START CR.	30,600 FT.	FUEL BURNED	97,943 LBS.
ALT. END CR.	33,800 FT.		



FIGURE 6 HPP

PERFORMANCE DATA - 368 PASSENGERS

OWE	416,743 LBS.	FUSELAGE LENGTH	261.8 FT.
PAYLOAD	77,000 LBS.	FUSELAGE DEPTH	22.31 FT.
FUEL	278,320 LBS.	FUSELAGE WIDTH	21.25 FT.
TOGW	772,063 LBS.	WING SPAN	186.9 FT.
RANGE	5,079 N. MI.	THRUST/WEIGHT	.25
W/S GROSS	131 LBS/FT. ²	MACH NO.	.82
S _{REF}	5,017 FT. ²	THRUST	48,254 LBS/ENGINE
S _{GROSS}	5,893 FT. ²	ENERGY REQ'D	2744 BTU/PASS. MI.
BURNED FUEL	238,394 LBS.	ALT. START CR.	27,500 FT.
		ALT. END CR.	35,000 FT.

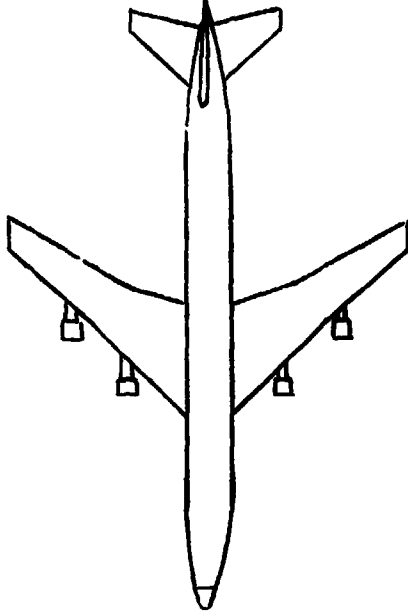

PERFORMANCE DATA - 416 PASSENGERS

OWE	424,088 LBS.	FUSELAGE LENGTH	261.8 FT.
PAYLOAD	87,200 LBS.	FUSELAGE DEPTH	22.31 FT.
FUEL	278,320 LBS.	FUSELAGE WIDTH	21.25 FT.
TOGW	789,608 LBS.	WING SPAN	186.9 FT.
RANGE	4,965 N. MI.	THRUST/WEIGHT	.25
W/S GROSS	134 LBS/FT. ²	MACH NO.	.82
S _{REF}	5,017 FT. ²	THRUST	49,350 LBS/ENGINE
S _{GROSS}	5,820 FT. ²	ENERGY REQ'D	2472 BTU/PASS. MI.
		BURNED FUEL	237,656 LBS.
		ALT. START CR.	29,500 FT.
		ALT. END CR.	36,600 FT.



FIGURE 7 MFU

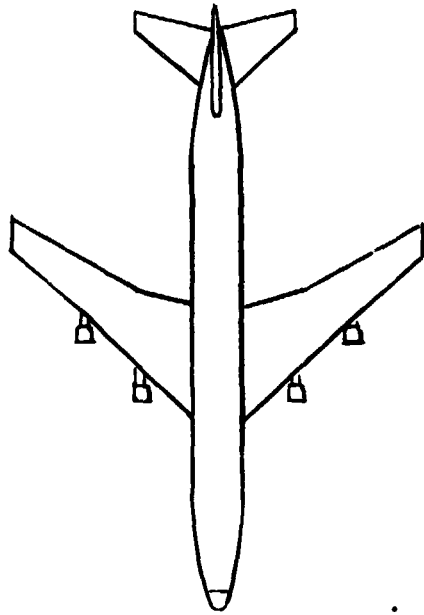

PERFORMANCE DATA - 368 PASSENGERS

ONE	408,743 LBS.	FUSELAGE LENGTH	261.8 FT.
PAYLOAD	~77,000 LBS	FUSELAGE DEPTH	22.31 FT.
FUEL	278,320 LBS.	FUSELAGE WIDTH	21.25 FT.
TOGM	772,063 LBS.	WING SPAN	186.9 FT.
RANGE	5069 N. MI. ²	THRUST/WEIGHT	.25
W/S	132 LBS/FT. ²	MACH NO.	.82
S _{REF}	5017 FT. ²	THRUST	48,254 LBS/ENGINE
S _{GROSS}	5893 FT. ²	ENERGY REQ'D	2748 BTU/PASS. MI.
		FUEL BURNED	238,221 LBS.
		ALT. START CR.	30,000 FT.
		ALT. END CR.	37,300 FT.

FIGURE 8 MFO

PERFORMANCE DATA - 368 PASSENGERS

OWE	440,978 LBS.	FUSELAGE LENGTH	227.7 FT.
PAYLOAD ~	77,000 LBS.	FUSELAGE DEPTH	22.3 FT.
FUEL	297,558 LBS.	FUSELAGE WIDTH	21.25 FT.
TOGW	815,528 LBS.	WING SPAN	192.8 FT.
RANGE	4,938 N. MI.	THRUST/WEIGHT	.237
W/S	130, LBS/FT. ²	MACH NO.	.82
S _{GROSS}	6,273 FT. ²	THRUST	48,254 LBS/ENG.
S _{REF}	5,341 FT. ²	ENERGY REQ'D	3015 BTU/PASS. MI.
		BURNED FUEL	254,575 LBS
		ALT. START CR.	29,000 FT.
		ALT. END CR.	36,400 FT.

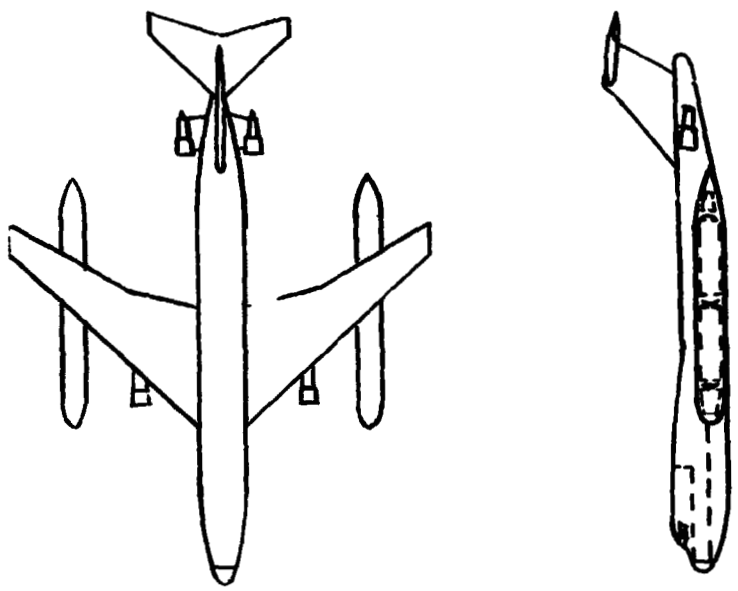

FIGURE 9 MPU

CHARACTERISTICS OF SYNTHETIC FUELS AND
COMPARISONS WITH JP-4 AND GASOLINE

Fuel (Formula)	Heat of Combustion* (BTU/lb) (BTU/gal)**	Density** (lb/ft ³)	Boiling Point (°F)	Ignition Temperature (°F)	Ease of Storage (1-easiest)	Toxicity (1-least toxic)	Flammability Limits In air (% by volume)
Hydrogen H ₂	51,600 30,400	4.4	-423	1,085	8	1	4.0 - 75.0
Ammonia NH ₃	8,000 45,600	42.6	-28	—	4	6	15.0 - 28.0
Hydrazine N ₂ H ₄	7,170 60,500	63.1	236	166**	3	7	4.7 - 100.0
Methanol CH ₃ OH	8,580 56,700	49.4	149	800	2	5	6.0 - 36.5
Ethanol C ₂ H ₅ OH	11,530 76,000	49.3	173	700	1	4	3.5 - 19.0
Methane CH ₄	21,500 74,500	25.9	-259	1,200	6	2	5.0 - 15.0
Propane C ₃ H ₈	19,900 97,000	36.5	-44	—	5	3	2.1 - 9.5
Acetylene C ₂ H ₂	20,734 —	—	-119	635	7	—	2.3 - 80.0
Gasoline JP-4	19,100 112,000 18,600 121,000	43.8 48.7	257 210	— 480	(1) (1)	(4) (4)	1.1 - 7.0 0.8 - 5.6

*Lower heating values

**Liquid

++Hydrate

Source: 1973 Summer Design Team Data, LaRC

TABLE I

DRAG COEFFICIENT C_{DP} MIN SUMMARY

CONFIG. ITEM	HFO	HFO	HPT/H _{FO}	HPP	HPP	MFU	MFU	MFU	MFO	MPU
	ΔC_{DP} MIN	ΔC_{DP} MIN	ΔC_{DP} MIN	ΔC_{DP} MIN	ΔC_{DP} MIN	ΔC_{DP} MIN	ΔC_{DP} MIN	ΔC_{DP} MIN	ΔC_{DP} MIN	ΔC_{DP} MIN
BODY	.00769	.00711	.00611	.00562	.00545	.00523	.00523	.00549	.00457	
WING	.00494	.00494	.00511	.00513	.00497	.00514	.00514	.00514	.00490	
H. TAIL	.00161	.00149	.00158	.00147	.00142	.00127	.00127	.00127	.00120	
V. TAIL	.00108	.00100	.00106	.00099	.00096	.00086	.00086	.00086	.00075	
FAN COWLS	.00066	.00061	.00065	.00061	.00059	.00053	.00053	.00053	.00049	
PYLONS	.00051	.00047	.00050	.00047	.00046	.00041	.00041	.00041	.00038	
FLAP TRACKS	.00055	.00051	.00054	.00051	.00049	.00044	.00044	.00044	.00042	
INTERFER.	.00120	.00120	.00120	.00120	.00120	.00120	.00120	.00120	.00120	
TANKS-PODS			.00497	.00565	.00548				.00282	
TOTAL	.01824	.01734	.02172	.02165	.02102	.01508	.01508	.01534	.01672	
BASIC POLAR	.01200	.01200	.01200	.01200	.01200	.01200	.01200	.01200	.01200	
CDXT	.00624	.00534	.00972	.00965	.00902	.00308	.00308	.00334	.00472	
SREF.	3950 ft ²	4270 ft ²	4041 ft ²	4338 ft ²	4476 ft ²	5017 ft ²	5017 ft ²	5017 ft ²	5341 ft ²	
W/Sgross	128	128	12 ^r	124	125	130	130	130	130	
TOGW	592,932	638,527	584,494	631,632	657,128	772,063	789,603	772,063	815,528	
Sgross	4642 ft ²	5020 ft ²	4746 ft ²	5095 ft ²	5257 ft ²	5893 ft ²	5893 ft ²	5893 ft ²	6273 ft ²	
BODY l/d	11.25	11.25	10.7	10.6	10.6	12.32	12.32	12.32	10.7	
BODY d	24.0 ft	24.0 ft	21.25 ft	21.25 ft	21.25 ft	21.25 ft	21.25 ft	21.25 ft	21.25 ft	
BODY l	3240 in	3240 in	2732 in	2702 in	2702 in	3142 in	3142 in	3142 in	2732 in	
WING SPAN	165.8 ft	172.1 ft	166.7 ft	173.75 ft	176.5 ft	186.8 ft	186.8 ft	186.8 ft	192.8 ft	
WING AR	6.96	6.96	6.96	6.96	6.96	6.96	6.96	6.96	6.96	
AC/A	37.5°	37.5°	37.5°	37.5°	37.5°	37.5°	37.5°	37.5°	37.5°	
λ	.356	.356	.356	.356	.356	.356	.356	.356	.356	
t/c	8.8%	8.8%	8.8%	8.8%	8.8%	8.8%	8.8%	8.8%	8.8%	
M.A.C.	307.5 in	319.9 in	311.0 in	322.5 in	327.2 in	346.5 in	346.5 in	346.5 in	357.6 in	
PAYLOAD	368 pass	480 pass	368 pass	364 pass	438 pass	368 pass	416 pass	368 pass	368 pass	

TABLE II

GROUP WEIGHT STATEMENT

	Configuration →		Liquid Hydrogen LH ₂		HPT/HPU		HPP		Liquid Methane LCH ₄		MPU	
	Passengers →	368	480	HFO	368	364	438	368	416	MFO	368	368
Wing	65500	66100	88011	96545	97095	94907	95165	94907	95165	94907	94907	12600
Horizontal Tail	6787	6787	6787	6787	6787	6657	6657	6657	6657	6657	6657	6657
Vertical Tail	7968	7968	7968	3983	3983	3780	3780	3780	3780	3780	3780	3780
Canard	0	0	0	0	0	0	0	0	0	0	0	0
Fuselage	92800	92800	73226	133270	133270	80226	80226	80226	80226	80226	80226	80226
Landing Gear	31325	31325	31325	31325	31325	31325	31325	31325	31325	31325	31325	31325
Nacelle	7074	7074	7074	7074	7074	7074	7074	7074	7074	7074	7074	7074
Structure Total	(211454)	(212054)	(215091)	(279034)	(279534)	(223969)	(224227)	(223969)	(224227)	(223969)	(223969)	(255062)
Engines	40464	40464	40464	40464	40464	40464	40464	40464	40464	40464	40464	40464
Thrust Reversers	6706	6706	6706	6706	6706	6706	6706	6706	6706	6706	6706	6706
Miscellaneous Systems	1780	1780	1780	1780	1780	1780	1780	1780	1780	1780	1780	1780
Fuel Sys-Tanks & Plumb.	48350	48350	27865	11405	11405	44000	44000	44000	44000	44000	44000	29523
-Insulation	7730	7730	8085	5703	5703	7142	7142	7142	7142	7142	7142	147.1
Propulsion Total	(105030)	(105030)	(84900)	(66058)	(66058)	(100092)	(100092)	(100092)	(100092)	(100092)	(100092)	(93234)
Surface Controls												
Auxiliary Power												
Instruments												
Hydraulics												
Electrical												
Avionics												
Furnishings & Equipment												
Air Conditioning												
Anti-Icing												
Systems & Equipment Total	(73415)	(86474)	(73415)	(73415)	(81611)	(73415)	(79012)	(73415)	(79012)	(73415)	(73415)	(73415)
Mfg. & Certif Tolerance												
Weight Empty	389899	403558	373406	418507	427203	397476	403331	397476	403331	397476	397476	421711
Crew and Baggage-Flight, 3												
-Cabin, 7												
Unusable Fuel	19033	22569	19033	19033	21186	19267	20757	19267	20757	19267	19267	19267
Engine Oil												
Passenger Service												
Cargo Containers, 4												
Operating Weight	408932	426127	392439	437540	448389	416743	424088	416743	424088	416743	416743	440978
Passengers	77000	100400	77000	77000	91647	77000	87200	77000	87200	77000	77000	77000
Passenger Baggage												
Cargo												
Zero Fuel Weight	485932	526527	469439	514540	540036	493743	511288	493743	511288	493743	493743	517978
Mission Fuel	107000	112000	115055	117092	117092	278320	278320	278320	278320	278320	278320	297558
Design Gross Weight	592932	638527	584494	631632	657128	772063	789608	772063	789608	772063	772063	815528

TABLE III

CONFIGURATION COMPARISON

	Liquid Hydrogen LH ₂		HPT/HPU		HPP		Liquid Methane LCH ₄		
	HFO	480	368	364	438	368	MFU	MFO	MPU
No. of Passengers	368	480	368	364	438	368	416	368	368
Operating Weight Empty	408932	426127	392439	437540	448389	416743	424088	416743	440978
Payload	77000	100400	77000	77000	91647	77000	87200	77000	77000
Zero Fuel Weight	485932	526527	469439	514540	540036	493743	511288	493743	517978
Mission Fuel Weight	107000	112000	115055	117092	117092	278320	278320	278320	297558
Takeoff Gross Weight	592932	638527	584494	631632	657128	772063	789603	772063	815528
Fuel Burned	90113	94250	97048	98263	97943	238394	237656	238221	254373
Range	4978	4950	4992	4639	4483	5079	4965	5069	4938
Energy Required	2654	2047	2726	3003	2573	2744	2472	2748	3015

TABLE IV

PERFORMANCE DATA
OF
STANDARD 747-100 FOR COMPARATIVE PURPOSES

OWE	355,400 LBS.	FUSELAGE LENGTH	227.7 FT.
PAYLOAD	77,000 LBS. (368 PASS.)	FUSELAGE DEPTH	22.3 FT.
TOGW	710,000 LBS.	FUSELAGE WIDTH	21.25 FT.
RANGE	5,000 N.MI.	WING SPAN	195.7 FT.
W/S	121 LBS/FT. ²	T/W	.23
S _{REF}	5,500 FT. ²	MACH NO.	.82
S _{GROSS}	5,857 FT. ²	THRUST	40,900 LBS/ENGINE
		ENERGY REQ'D	2350 BTU/PM
		BURNED FUEL	235,000 LBS.

TABLE V