



NATIONAL AERONAUTICS AND SPACE ADMINISTRATION  
WASHINGTON, D.C. 20546

Napo

SEP 24 1974

REPLY TO  
ATTN OF: GP

TO: KSI/Scientific & Technical Information Division  
Attn: Miss Winnie M. Morgan

FROM: GP/Office of Assistant General  
Counsel for Patent Matters

SUBJECT: Announcement of NASA-Owned U.S. Patents in STAR

In accordance with the procedures agreed upon by Code GP and Code KSI, the attached NASA-owned U.S. Patent is being forwarded for abstracting and announcement in NASA STAR.

The following information is provided:

U.S. Patent No. : 3,832,764

Government or : Cal/Tech  
Corporate Employee : Pasadena, CA

Supplementary Corporate : \_\_\_\_\_  
Source (if applicable)

NASA Patent Case No. : NPO-13,157-1

NOTE - If this patent covers an invention made by a corporate employee of a NASA Contractor, the following is applicable:

YES  NO

Pursuant to Section 305(a) of the National Aeronautics and Space Act, the name of the Administrator of NASA appears on the first page of the patent; however, the name of the actual inventor (author) appears at the heading of column No. 1 of the Specification, following the words "...with respect to an invention of ..."

*Bonnie L. Woerner*

Bonnie L. Woerner  
Enclosure

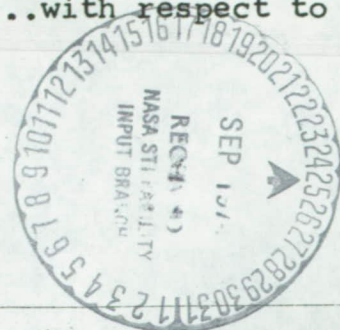

N74-32918  
Unclas 47515  
00/15  
CSCCL 131  
TOOL FOR USE IN  
PATENT OBJECTS  
LIFTING PIN SUPPORTED  
(NASA) 3 P  
NPO-13157-1

- [54] **TOOL FOR USE IN LIFTING PIN-SUPPORTED OBJECTS**
- [76] Inventors: **James C. Fletcher**, Administrator of the National Aeronautics and Space Administration, with respect to an invention of; **Ronald A. Marzek**, 5162 Stratford Ave., Westminster, Calif. 92683; **William S. Read**, 3336 Sparr Blvd., Glendale, Calif.
- [22] Filed: **June 18, 1973**
- [21] Appl. No.: **370,872**
- [52] U.S. Cl. .... **29/203 H, 29/268**
- [51] Int. Cl. .... **B25b 27/02**
- [58] Field of Search ..... **29/203 H, 268, 203 HT, 29/203 HC, 206**

3,588,983 6/1971 Hoy ..... 29/203 H

*Primary Examiner*—Thomas H. Eager  
*Attorney, Agent, or Firm*—Monte F. Mott; John R. Manning; Paul F. McCaul

[57] **ABSTRACT**

A tool for use in lifting a pin-supported, electronic package mounted in juxtaposition with the surface of an electronic circuit board. The tool is configured to be received beneath a pin-supported package and is characterized by a manually operable linkage, including an elongated body within which an elongated, rigid link is supported for axial reciprocation and a pivotal link pinned to the body and supported for oscillation induced in response to axial motion imparted to the rigid link. A lifting plate is pivotally coupled to the distal end of the pivotal link so that oscillatory motion imparted to the pivotal link serves to move the plate vertically for elevating the plate into lifting engagement with the electronic package positioned thereabove.

- [56] **References Cited**
- UNITED STATES PATENTS**
- 3,177,567 4/1965 Gehrman ..... 29/268 X
- 3,443,297 5/1969 Lusby, Jr. .... 29/206 X
- 3,516,142 6/1970 De Rose et al. .... 29/203 H

**5 Claims, 7 Drawing Figures**

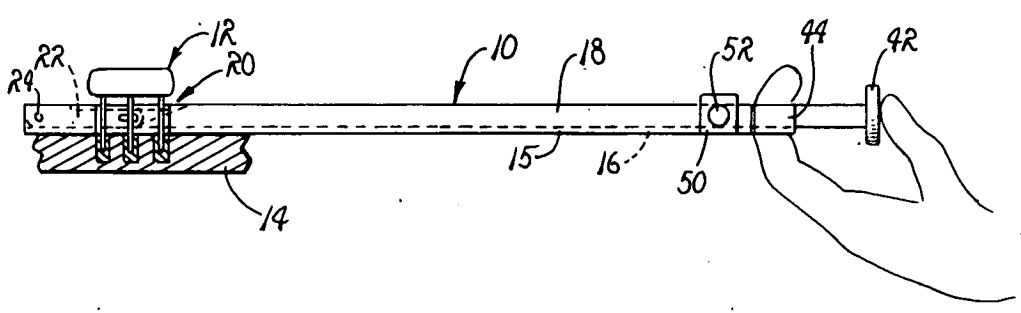

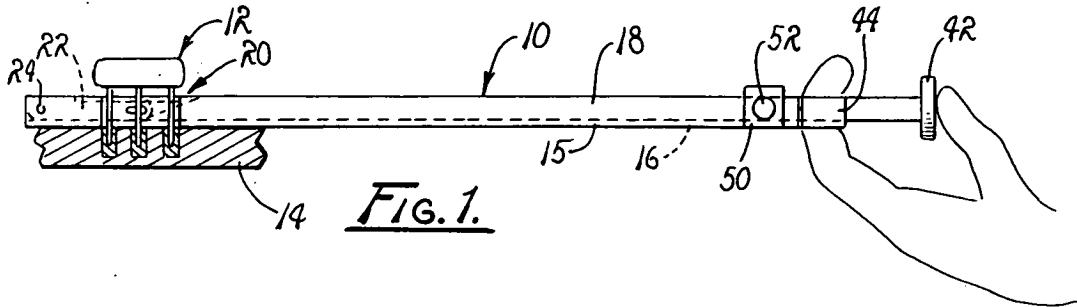

FIG. 1.

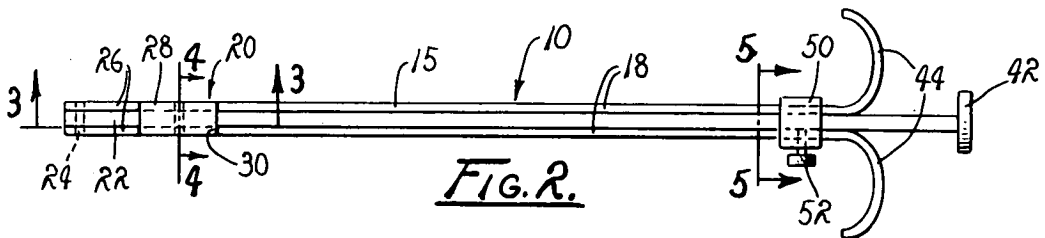

FIG. 2.

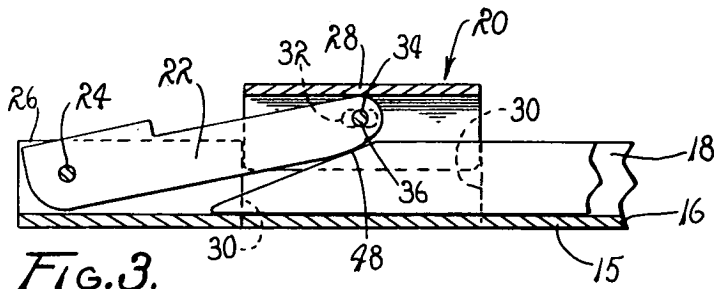

FIG. 3.

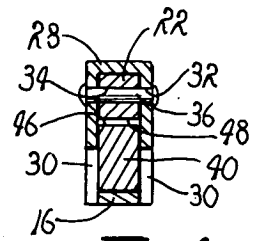

FIG. 4.

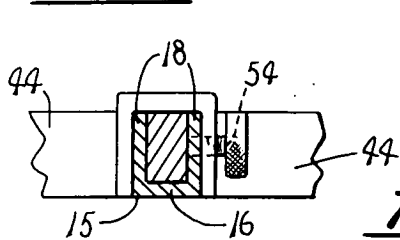

FIG. 5.

FIG. 6.

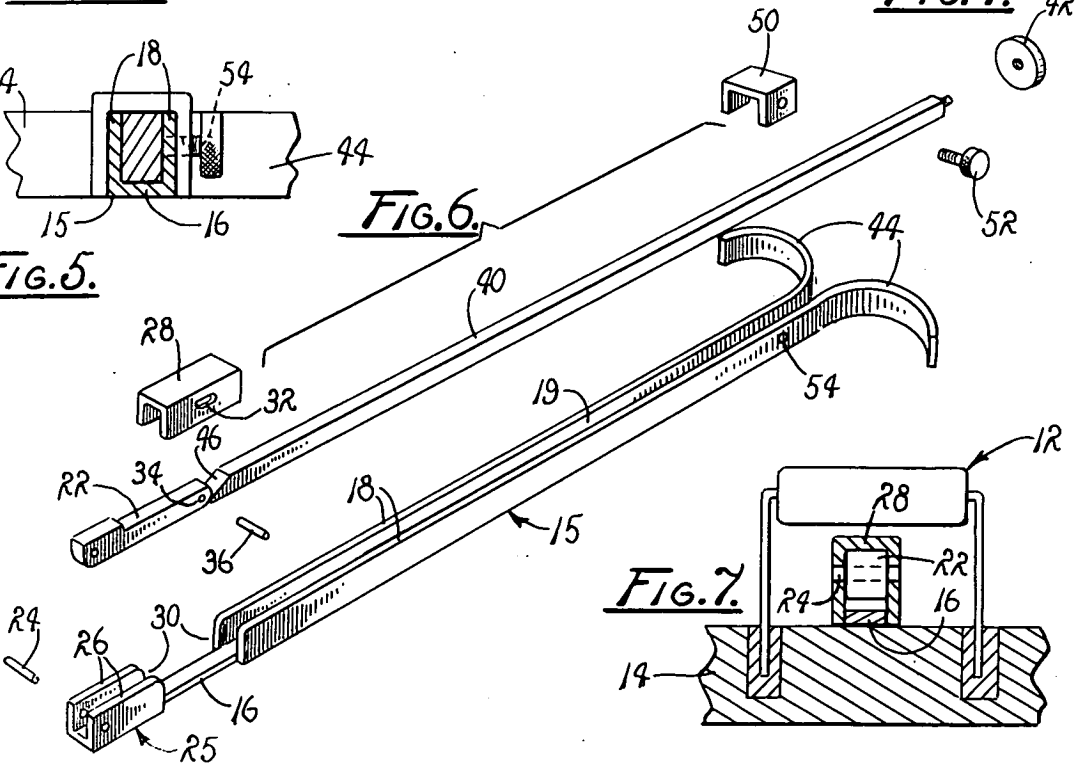

FIG. 7.

upstanding legs arranged in substantial parallelism, and said rigid link is disposed between the legs.

3. The tool of claim 2 wherein said means responsive to axial motion imparted to said link includes a pivotal link supported for oscillation about a first pivotal axis extending through the base portion of said pivotal link and in orthogonal relation with said longitudinal axis of symmetry, and a plate having an inverted U-shaped configuration pivotally coupled with said pivotal link and supported for oscillation about a second pivotal axis extended through the distal end portion of the pivotal link in parallelism with said first pivotal axis.

4. The tool of claim 3 wherein said linkage means further includes a cam surface of a wedge-shaped configuration formed at one end of said rigid link and a cam follower surface of a substantially arcuate configuration formed at the distal end of said pivotal link in juxtaposition with said cam surface, whereby selected axial motion imparted to said link causes said cam surface to engage said cam follower surface for imparting arcuate motion to said pivotal link.

5. A manually operable tool for use in lifting an electronic package supported above the surface of a circuit board by mutually spaced, vertically oriented pins seated in sockets formed in the board comprising:

- A. an elongated body of a substantially U-shaped cross-sectional configuration having a pair of laterally spaced vertically oriented walls extending in

parallelism with the longitudinal axis of symmetry of said body;

B. an elongated rigid link of a substantially rectangular configuration supported for axial reciprocation along a path extended between the walls of said body, in parallelism therewith, said link being characterized by a thumb plate disposed in spaced relation with a first end of said body and a camming surface disposed at the opposite end thereof, adjacent to the second end of said body;

C. a force applicator including a pivotal link pinned at its base end portion to said body and supported for oscillatory motion about an axis orthogonally related to the longitudinal axis of said body, a lifting plate, means including a lost-motion linkage coupling said lifting plate to the distal end portion of said pivotal link for oscillatory motion about the distal end thereof, and a cam-follower surface provided at the distal end of said pivotal link within the path of said rigid link for engaging said camming surface as selected axial motion is imparted to the rigid link whereby said plate is displaced into lifting engagement with said package; and

D. a pair of oppositely curved arcuate members extended from said body at opposite sides of said axis of symmetry adapted to be received by a pair of mutually spaced human fingers.

\* \* \* \* \*

30

35

40

45

50

55

60

65