

SPACE SCIENCES LABORATORY

Final Report

LUNAR SOIL PROPERTIES AND SOIL MECHANICS

Carried out between 20 June 1970 and
30 September 1973

NASA Grant NGR 05-003-406

Principal Investigator: Prof. James K. Mitchell

Co-Investigator: Prof. William N. Houston

June 1974

Space Sciences Laboratory Series 15 Issue 36

UNIVERSITY OF CALIFORNIA, BERKELEY

(NASA-CR-140117) LUNAR SOIL PROPERTIES
AND SOIL MECHANICS FIELD REPORT 2,
Jun. 1970 - 30 Sep. 1973 (California
Univ.) 51 p HC \$6.25

N74-3426

INCL 4
4321

SOIL 31

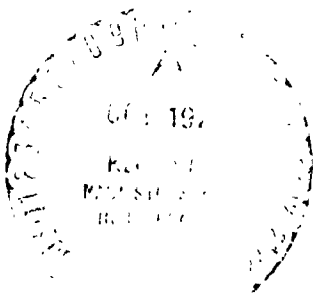

Space Sciences Laboratory
University of California, Berkeley

Final Report

LUNAR SOIL PROPERTIES AND SOIL MECHANICS

Covering research under

NASA Grant NGR 05-003-406

Carried out between 20 June 1970 and 30 September 1973

Principal Investigator: James K. Mitchell,
Professor of Civil Engineering

Co-Investigator: William N. Houston,
Associate Professor of
Civil Engineering

June 1974

Submitted to the National Aeronautics and Space Administration,
Scientific and Technical Information Facility,
College Park, Maryland 20740

Space Sciences Laboratory Series 15, Issue 36

PREFACE

This report, prepared by the University of California, Berkeley, summarizes the results of research under NASA Grant NGR 05-003-406, Lunar Soil Properties and Soil Mechanics. Technical liaison for this work was conducted by the Assistant Administrator for University Affairs.

James K. Mitchell, Professor of Civil Engineering, was Principal Investigator for these studies, and William N. Houston, Associate Professor of Civil Engineering, was Co-Investigator. Professional research personnel who participated in various phases of the studies made as a part of this Grant included three faculty, three Assistant Research Engineers, and nine Graduate Student Research Assistants.

CONTENTS

	<u>Page</u>
Preface	11
Introduction	1
Penetration Resistance of Lunar Soils	4
Pressure Distribution and Soil Failure Beneath a Towed, Rigid Spherical Wheel in Air Dry Sand	6
Stress-Deformation Study of a Simulated Lunar Soil	7
Lunar Soil Porosity and its Variation as Estimated from Footprints and Boulder Tracks	9
Model Studies of the Failure Mechanism Associated with a Sphere Rolling Down a Soil Slope	10
Flow in Porous Media under Rarefied Gas Conditions	11
Static Penetration Resistance of Soils	13
Static Penetration Resistance of Cohesionless Soils	14
Boulder Tracks and Nature of Lunar Soil	15
Downslope Movement of Lunar Soil and Rock Caused by Meteoroid Impact	16
Static Penetration Resistance of Soils	17
Mechanics of Wheel-Soil Interaction	18
In-Situ Strength by Static Cone Penetration Test	20
The Nature of Lunar Soil	21
Fabric-Mechanical Property Relationships in Fine Granular Soils	22
The Influence of Gravity, Prestress, Compressibility and Layering on Soil Resistance to Static Penetration	24
Determination of In-Situ Soil Properties Utilizing an Impact Penetrometer	26

	<u>Page</u>
Effect of Gradation on Lunar Soil Response to Loading	55
Distribution List	57

INTRODUCTION

The long-range objectives of the research summarized herein were to develop methods of experimentation and analysis for determination of the physical properties and engineering behavior of lunar surface materials under in situ environmental conditions. Data for this purpose were obtained from on-site manned investigations, orbiting and soft-landed spacecraft, and terrestrial simulation studies. Knowledge of lunar surface material properties are needed for development of models for several types of lunar studies and for the investigation of lunar processes. The results should also have direct engineering application when manned missions to the Moon are again undertaken.

NASA Sponsorship of lunar soil mechanics research was initiated at Berkeley in 1967 under contract to the Marshall Space Flight Center. The results of these studies are described in a series of reports as follows:

A. Materials Studies Related to Lunar Surface Exploration, March 1969
NASA Contract NSR 05-003-189

Volume I: Lunar Soil and Rock Problems, Engineering Properties of Lunar Soils, Lunar Stratigraphy, Geochemical Studies

Volume II: Geophysical Methods, Rock Behavior

Volume III: Trafficability, Friction and Adhesion in Vacuum, Lunar Soils for Radiation Shielding

Volume IV: Rock Deformability, Probes for Permeability and Thermal Conductivity

Summary Technical Report (April 1969)

B. Lunar Surface Engineering Properties Experiment Definition,
January 1970
NASA Contract NAS 8-21432

Volume I: Mechanics and Stabilization of Lunar Soils

Volume II: Lunar Soil Properties from Photographic Records

Volume III: Borehole Probes

Volume IV: Fluid Conductivity of Lunar Surface Materials

Summary Technical Report

C. Lunar Surface Engineering Properties Experiment Definition,
July 1971
NASA Contract NAS 8-21432

Volume I: Mechanics, Properties and Stabilization of Lunar Soils

Volume II: Mechanics of Rolling Sphere-Soil Slope Interaction

Volume III: Borehole Probes

Volume IV: Fluid Conductivity of Lunar Surface Materials

Summary Technical Report

Sponsorship of the continuing program of research was transferred to NASA Headquarters, Office of University Affairs, in June 1970. The present report summarizes the results of studies made since then. The detailed results of most of the phases of the research program are available in reports and papers already submitted, and in graduate student theses, so they will not be presented again here. Instead, this support consists of abstracts of papers, reports, and theses containing the results of research supported wholly or in part by NASA Grant NGR 05-003-406.

It should be noted also that most of the research under this Grant was done during the period of the Apollo program, while the investigators were engaged concurrently with the Soil Mechanics Experiment (S-200)

assigned to Apollo Missions 14 through 17. Although that work was supported separately under contract to the NASA Johnson Space Center, complete separation of the two programs was neither practical nor desirable, since many aspects of the work were complementary.

"Penetration Resistance of Lunar Soils," by W. N. Houston and L. I. Namiq (1970) Proceedings of the Symposium on Off-Road Mobility, Los Angeles, California, Nov. 3-4, 1970, TRW Systems Group and International Society for Terrain Vehicles Systems. (Also published in the Journal of the Terra Mechanics, Vol. 8, No. 1, 1971, pp. 59-69).

ABSTRACT

Penetration resistance, in terms of the slope of the stress-penetration curve, G , has been correlated with density for a basaltic lunar soil simulant. The G values were measured with the standard Waterways Experiment Station 30° cone penetrometer. This lunar soil simulant has been found to possess the same penetration resistance characteristics as the Apollo 11 lunar soil.

Bearing capacity equations have been used to determine G values for the lunar soil simulant at various densities by computing the increase in bearing capacity with depth for the cone penetrometer. The G values thus obtained were found to agree very well with the measured G values. Using the same bearing capacity equations, the computations were repeated for the lunar gravity field by reducing the material unit weight by a factor of six. These G values were obtained for a range in soil density and represent a predicted correlation between G and density for the lunar surface.

This correlation has been entered with density estimates obtained from Apollo core tube studies as well as independent density estimates obtained from astronaut footprint depth analyses. The probable range in G value obtained for the lunar surface is expected to be useful in evaluation of Lunar Roving Vehicle performance. In addition, the correlation between G and density obtained for the lunar soil simulant under terrestrial

gravity may be useful in evaluating the suitability of any new soil proposed for lunar trafficability studies. This data may also be of value for terrestrial applications as a typical example of a G-density correlation for a clean sandy silt.

"Pressure Distribution and Soil Failure Beneath a Towed, Rigid Spherical Wheel in Air Dry Sand," by H. John Hovland and James K. Mitchell (1970) Proceedings of the Symposium on Off-Road Mobility, Los Angeles, California, Nov. 3-4, 1970, TRW Systems Group and International Society for Terrain Vehicles Systems, pp. 108-127.

ABSTRACT

As a part of an investigation of lunar boulder track phenomena, an instrumented rigid spherical wheel was towed on Yuma sand to enable determination of contact pressure at the wheel-soil interface. Track formation, pressure distribution, slip, and shear failure were determined as a function of wheel load.

Tracks were photographed and measured in detail to permit analysis of soil deformation and failure. It is shown that the contact pressure distribution can be approximated with a parabolic function and that shear failure beneath the rolling wheel is a function of the maximum rather than the average contact pressure.

Taken together with the results of model studies of the failure mechanism, these investigations may provide a basis for improved theory for the analysis of terrain-vehicle interaction.

"Stress-Deformation Study of a Simulated Lunar Soil," by Laith I. Namiq (1970) Dissertation submitted in partial fulfillment for degree of Doctor of Philosophy, Department of Civil Engineering, University of California, Berkeley, December.

ABSTRACT

The primary objective of this research was to determine the mechanical properties of lunar soil. A secondary objective was to develop analytical tools which would be useful for terrestrial applications.

The approach used is that of selecting and preparing a lunar soil simulant which behaves under applied load in a way similar to actual lunar soil. An extensive analysis of the properties and behavior of this simulant under terrestrial conditions was made, and the results were transferred to the lunar surface by means of an analytical model.

The method of study used is an analytical-experimental approach which leads to the formulation and solution of a boundary value problem. Experimental work included laboratory measurements of strength, stress-strain, and compressibility parameters and performance of model plate load tests. Analytical work included: (1) mathematical description of the strength, stress-strain, and compressibility parameters, including their dependence on soil density and (2) use of the finite element method of analysis to simulate the model plate load tests for both terrestrial and lunar gravity conditions. Before applying the finite element method to the solution of boundary value problems on the lunar surface, the method was checked by comparison of predicted stress-deformation curves with measured stress-deformation curves for the series of laboratory plate load tests, and the agreement was very good. No general shear failure was observed in the laboratory model tests nor indicated by theoretical

analysis - although plate settlements under load were as much as 1 and 2 plate widths. Theoretical analyses showed that most of the soil deformation under plate loading was due to compression rather than shear displacements.

The solution for a similar series of plate load tests under lunar gravity was used to obtain a measure of the effect of reduced gravity in terms of gravity reduction factors. The deformation of the lunar soil simulant, loaded by a plate with a contact pressure of 1 psi, in the lunar gravity field was found to be about 2.5 times its deformation under the same soil conditions but in an earth gravity field. The gravity reduction factors together with laboratory-conducted boot imprint tests, were used to relate astronaut footprint depth to the average void ratio for the top 15 cm of the lunar soil surface. Estimates of the range in astronaut footprint depths from Apollo 11 and 12 photographs correspond to an estimated range in void ratio of 0.86 to 0.66 with an average value of 0.77 for the top 15 cm of the lunar soil surface. This corresponds to an in situ density of about 1.75 gm/cm³ for a specific gravity of 3.1. The mechanical properties corresponding to this density were computed from the developed relationships between density and lunar soil mechanical properties.

Predicted plate load test curves for a range of plate sizes and soil densities were developed with the finite element computer program. These curves were proposed as a basis for evaluation of any plate load test data which may be returned from future manned lunar landings.

The finite element program developed for this study appears suitable for solution of stress-deformation problems for relatively compressible soils such as partially saturated silts and clays, and saturated clays under drained loading as well as for relatively incompressible soils such as dense sands.

"Lunar Soil Porosity and its Variation as Estimated from Footprints and Boulder Tracks," by W. N. Houston, H. J. Hovland, J. K. Mitchell and L. I. Namiq (1972) Proceedings of the Third Lunar Science Conference (Supplement 3, Geochimica et Cosmochimica Acta) Vol. 3, pp. 3255-3263, The MIT Press.

ABSTRACT

Statistical variation in lunar soil porosity has been assessed through analyses of astronaut footprints and imprints made by rolling boulders. The mean porosities and standard deviations were found to be about the same for the level, intercrater areas for each of the four Apollo sites. For 273 observations of footprint depth at the four sites combined, a mean porosity of 43.3% and a standard deviation of 2.8% were obtained for the upper 15 cm. The analyses indicate a gradually decreasing porosity with depth, although local deviations from this pattern are known to occur. The equivalence of mean porosity and standard deviation for the four Apollo sites suggests that the lunar processes affecting the porosity of the upper few cm may have reached a steady state.

Porosities of crater rim material and crater and rille slopes were found to be somewhat higher, with an average value of about 46 to 47%, but occasionally much higher.

The variations in porosity were found to occur on a relatively small scale--probably of the order of a few meters. This result indicates that it is very unlikely that the porosity at a given lunar traverse station stop could be characterized by one or two core tube samples.

"Model Studies of the Failure Mechanism Associated with a Sphere Rolling Down a Soil Slope," by H. J. Hovland and J. K. Mitchell (1972) Journal of Terramechanics, Vol. 9, No. 1, pp. 37-50, Pergamon Press.

ABSTRACT

The paper describes model studies enabling further insight into the soil failure mechanisms associated with a sphere rolling down a sand slope. This failure mechanism, although specifically investigated for a rigid sphere-spherical wheel, is believed to be applicable to other cases of wheel-soil interaction as well. The paper is part of a more extensive investigation directed at the study of lunar problems in soil mechanics and vehicle mobility, wherein theory was proposed for analysis of freely rolling or pulled rigid spherical wheels. The type of physical model described can be used to investigate the three-dimensional pattern of deformations resulting from any type of static load-soil interaction.

"Flow in Porous Media under Rarefied Gas Conditions," by F. C. Hurlbut and C. R. Jih (1972) Final Report for Research Phase: Fluid Conductivity of Lunar Surface Materials, prepared for NASA Headquarters, Washington, D. C., under NASA Grant NGR 05-003-406, Geotechnical Engineering Report, University of California, Berkeley, Space Sciences Laboratory Series 13, Issue 43, May.

ABSTRACT

This report brings to a conclusion research on the fluid conductivity of lunar surface materials under this grant, and summarizes investigations conducted on such phenomena between 1969 and 1971.

Within the initial period preliminary investigations indicated that:

1. Gas flow in lunar surface materials would be of the continuum, transitional and free-molecular types with the latter types always occurring at sufficient distances from gas sources.
2. New theoretical studies were needed to extend the framework within which analysis of experimental flow data might proceed.
3. Experimental studies were required to provide the physical basis for additional conceptual development.

Results of the theoretical and experimental programs responding to the above may be summarized as follows:

1. Theoretical methods were developed by Raghuraman¹⁰ for the analysis of transitional and free-molecular flows, and for analysis of lunar permeability probe data in general as described by Witherspoon and Katz (Mitchell, et al⁹), Witherspoon and Willis,¹³ and Hurlbut, et al.⁵
2. Experimental studies of rarefied flows under conditions of a large pressure gradient (described in the body of this report) have shown flows in the continuum regime to be responsible for the

largest portion of the pressure drop between source and sink for one dimensional flow, provided the entrance Knudsen number is sufficiently small, i.e., $Kn < 10^{-2}$.

3. The concept of local similarity (see Ref. 13 and present report) leading to a "universal" nondimensional function of Knudsen number was shown in the experimental work to have approximate validity. By means of this universal function, flows in all regimes may be described in terms of an area fraction and a single length parameter. However, slightly differing behaviors of the various samples in the free-molecular regimes were found, suggesting the desirability of an extension of the analysis to include two length parameters.
4. Synthetic porous media prepared from glass beads exhibited flow behavior similar in many regards to that of a natural sandstone. It is suggested that studies using artificial stones with known pore configurations will lead to new insight concerning the structure of natural materials.
5. The experimental method developed in this work involving the use of segmented specimens of large permeability has been shown to be fruitful in the context of these investigations.

"Static Penetration Resistance of Soils," by H. T. Durgunoglu, (1972) Dissertation submitted in partial fulfillment for degree of Doctor of Philosophy, Department of Civil Engineering, University of California, Berkeley, June.

ABSTRACT

Model test results have been used to define the failure mechanism associated with the static penetration resistance of cohesionless and low-cohesion soils. Knowledge of this mechanism has permitted the development of a new analytical method for calculating the ultimate penetration resistance which explicitly accounts for base apex angle and roughness, soil friction angle, and the ratio of penetration depth to base width. Curves relating the bearing capacity factors N_c and $N_{\gamma q}$ to the soil friction angle are presented for failure in general shear.

Strength parameters and penetrometer interaction properties of a fine sand were determined and used as the basis for prediction of the penetration resistance encountered by wedge, cone, and flat-ended penetrometers of different surface roughness using the proposed analytical method. Because of the close agreement between predicted values and values measured in laboratory tests, it now appears possible to deduce in-situ soil strength parameters and their variation with depth from the results of static penetration tests.

A procedure for determining the soil cohesion and friction angle from the results of static penetration tests is proposed. This procedure is illustrated by application to model test results, to penetration data presented by other investigators, and to penetration data obtained for the lunar surface by the Apollo 15 self-recording penetrometer and the Soviet Lunar Rover Lunokhod-1.

"Static Penetration Resistance of Cohesionless Soils," by H. Turan Durgunoglu and James K. Mitchell (1972) Meeting Preprint 1835, ASCE Annual and National Environmental Engineering Meeting, October 16-22, 1972, Houston, Texas, 30 pp.

ABSTRACT

The failure mechanism associated with deep static penetration in cohesionless soils has been determined using model tests. Bearing capacity factors that depend on friction angle, penetrometer tip shape, depth to penetrometer diameter ratio, and penetrometer to soil friction have been derived on the basis of the failure mechanism. Strength properties of a fine sand were determined and used as a basis for prediction of resistance to penetration by wedges, cones, and flat-ended penetrometers of different surface roughnesses. Comparison with measured penetration resistance gave close agreement.

Because of the good agreement between theory and measurement, it now appears possible to deduce in-situ strength parameters and density at depth on the basis of penetration test results for medium to dense soils which fail in general shear, or to estimate reliably the resistance to penetration if properties are known.

"Boulder Tracks and Nature of Lunar Soil," by H. John Hovland and James K. Mitchell (1973) *The Moon* (An International Journal of Lunar Studies, Dordrecht-Holland), D. Reidel Publishing Co., pp. 164-175, Vol. 6.

ABSTRACT

Boulder tracks from 19 different locations on the Moon, observable in Lunar Orbiter photographs, have been examined. Measurements of the track widths indicate that some of the boulders sank considerably deeper than others. It is suggested that lunar surface materials vary from place to place; the state of compaction (density of lunar soil) is probably one of the significant variables. Using bearing capacity theory, modified to be applicable to the rolling boulder problem by theoretical studies and extensive testing, the friction angle of the lunar soil was estimated. Most of the results were between 24 and 47 degrees with an arithmetic average of 37 degrees. These values suggest corresponding density variations of 1.25 to 2.00 g/cm³.

"Downslope Movement of Lunar Soil and Rock Caused by Meteoroid Impact," by W. N. Houston, Y. Moriwaki and C.-S. Chang (1973) Proceedings of the Fourth Lunar Science Conference (Supplement 4, Geochimica et Cosmochimica Acta) Vol. 3, pp. 2425-2435, The MIT Press.

ABSTRACT

The relative importance of downslope movement of lunar soil and rock caused by meteoroid-impact-induced vibrations as a mode of lunar soil "erosion" has been assessed. Magnitudes of downslope movements were estimated by superimposing meteoroid-impact-induced dynamic stresses on existing static stresses in slopes of various inclinations. Accelerations in excess of the yield accelerations were double-integrated to obtain an estimate of the movements. It was found that only the very steep lunar slopes have experienced significant downslope movements due to shaking from meteoroid impacts alone and that lunar slope degradation must arise primarily by other mechanisms.

"Static Penetration Resistance of Soils," by H. Turan Durgunoglu and James K. Mitchell (1973) Geotechnical Engineering report prepared for NASA Headquarters, Washington, D. C. under NASA Grant NGR 05-003-406, Lunar Soil Properties and Soil Mechanics, Space Sciences Laboratory, University of California, Berkeley, April.

ABSTRACT

Model test results were used to define the failure mechanism associated with the static penetration resistance of cohesionless and low-cohesion soils. Knowledge of this mechanism has permitted the development of a new analytical method for calculating the ultimate penetration resistance which explicitly accounts for penetrometer base apex angle and roughness, soil friction angle, and the ratio of penetration depth to base width. Curves relating the bearing capacity factors N_c and $N_{\gamma q}$ to the soil friction angle are presented for failure in general shear.

Strength parameters and penetrometer interaction properties of a fine sand were determined and used as the basis for prediction of the penetrometer resistance encountered by wedge, cone, and flat-ended penetrometers of different surface roughness using the proposed analytical method. Because of the close agreement between predicted values and values measured in laboratory tests, it appears possible to deduce in-situ soil strength parameters and their variation with depth from the results of static penetration tests.

A procedure for determining the soil cohesion and friction angle from the results of static penetration tests is proposed. This procedure is illustrated by application to model test results, to penetration data presented by other investigators, and to penetration data obtained for the lunar surface by the Apollo 15 self-recording penetrometer and the Soviet Lunar Rover Lunokhold-1.

"Mechanics of Wheel-Soil Interaction," by H. John Hovland (1973) Geotechnical Engineering report prepared for NASA Headquarters, Washington, D. C., under NASA Grant NGR 05-003-406, Space Sciences Laboratory, University of California, Berkeley, April.

ABSTRACT

When man first invented the wheel, he did so without any theory. Several thousand years later, when man first went to the moon, he built the wheel for the Lunar Roving Vehicle (LRV), again without adequate theory. If man had waited for exact theory, the LRV probably would not have been carried to the moon.

So it seems that the existentialist is right in saying that existence precedes essence; that discovery proceeds from conceiving the physical phenomenon, to supplementing this phenomenon with explanation, usually expressed by mathematical abstractions. At least in wheel-soil interaction, wheels have preceded theory. Thus, a theoretical framework for a physical phenomenon which is known to exist can be useful, but it is not essential.

This philosophical argument presents a fundamental restriction to the value of any theory. There are, however, other less fundamental but more immediate restrictions.

In reviewing trafficability literature and in contemplating such phenomena during the past two years, the author (schooled primarily in soil mechanics) has become impressed with the complexity of the general problem of off-road mobility (see, for example, Bekker, 1969). This problem does not consist merely of a single, ideal wheel operating in an ideal environment, but of coupled wheels operating both in ruts made by preceding wheels and in virgin terrain. Further, the traverse over such

a terrain is likely to include various soils, rocks, and bumps. The dynamic overall ride over such a terrain may, therefore, be only remotely related to theory developed for ideal wheel-soil conditions.

A general solution to a complex problem often results from research on separate aspects of the problem. This report presents a different and perhaps practically applicable theory on the very limited phenomenon of a rigid cylindrical wheel operating in a homogeneous soil. The developments are based on relatively simple considerations of statics and dynamics. Fundamental observations render the problem determinate. This leads to solutions of the sinkage and the pull which are likely to be within 15% of the correct value.

It is hoped that the theory presented in this report will be useful in evaluating and designing wheels for off-road mobility. Some new ideas are presented, and these need to be thoroughly checked and tested. It is hoped that concepts such as 1) the line of action of the resultant of radial stresses, 2) slip at a point, 3) the shear stress surface $\tau = f(\theta, s)$, 4) the closed-form approximate relation between contact angles and sinkage, 5) the general graphical solution for pull, 6) soil inertia forces, 7) equivalent cohesion, and 8) the performance surface, will inspire further thinking and relevant research.

"In-Situ Strength by Static Core Penetration Test," by J. K. Mitchell and H. T. Durgunoglu (1973) Proceedings, Eighth International Conference on Soil Mechanics and Foundation Engineering, Vol. 1.2, pp. 279-286, Moscow.

ABSTRACT

Model test results were used to define the failure mechanism associated with the static penetration of wedge and cone penetrometers into dense cohesionless and low cohesion soils. A new theory, presented in detail elsewhere, for ultimate tip resistance has been developed which accounts explicitly for cone angle, cone roughness, and ratio of penetration depth to cone base diameter.

Several examples are presented to show that predicted and measured penetration resistance versus depth relationships agree well. Procedures for determination of strength parameters from the results of static cone penetration tests are outlined and illustrated by application to model tests, to penetration data obtained from the literature, and to penetration resistance data for the lunar surface.

"The Nature of Lunar Soil," by W. David Carrier III, James K. Mitchell and Arshud Mahmood (1973) Journal of the Soil Mechanics and Foundations Division, ASCE, Vol. 99, No. SM10, Proc. Paper 10099, October, pp. 813-832.

ABSTRACT

The index properties of returned lunar soils from the United States Apollo and the Soviet Luna programs are reviewed. The scope of the paper includes lunar soil genesis, particle types, grain size distribution, grain shape distribution, specific gravity, minimum and maximum density, and relative density. The writers also present their own data for the latter three properties, as determined on three 1-gm submillimeter lunar samples taken on Apollo 14 and 15. The lunar soils are shown to be well-graded silty sands to sandy silts, composed of many different particle types (mineral fragments, glasses, agglutinates, basalts, and breccias) all produced primarily by meteorite impacts on the lunar surface. The specific gravity varies from 2.90 to 3.24 and the minimum and maximum bulk densities vary from 0.87 g/cm^3 to 1.10 g/cm^3 and from 1.51 g/cm^3 to 1.89 g/cm^3 , respectively. The insitu lunar soil can have a low relative density at the surface, increasing rapidly to a very high relative density at depths greater than 10 cm to 20 cm.

"Fabric-Mechanical Property Relationships in Fine Granular Soils," by Arshud Mahmood (1973) Dissertation submitted in partial fulfillment for degree of Doctor of Philosophy, Department of Civil Engineering, University of California, Berkeley.

ASSTRACT

As the behavior of soils depends upon the nature and arrangement of constituent particles, an investigation was carried out to study fabric-property relationships in soils composed mainly of fine sand and silt-sized particles. The study was prompted by an interest in the relationships between the deposition history, fabric and mechanical properties of lunar soils. The results of the study are equally applicable to terrestrial granular soils, as such soils are now known to acquire different fabrics when deposited in different ways, resulting in different mechanical properties for a given relative density.

Relationships between fabric and mechanical anisotropy were studied using a silty-fine sand composed of crushed basalt. The fabric was characterized by measuring preferred orientations of grains, and pore size distribution was determined by mercury intrusion porosimetry. When deposited by pouring the grains acquired strong preferred orientations in the horizontal direction and formed pores of 1 to 30 microns equivalent cylindrical diameter. Strength measured in direct shear was larger when the sample was sheared across the preferred orientation of grains than when the shearing was along the orientation direction. This is to be expected as shearing across the preferentially oriented grains involves breakage or reorientation of many grains.

Relationships between fabric and compressibility were studied in a medium grain sized beach sand with rounded and slightly elongated particles.

Fabric was characterized by determining grain orientation. One-dimensional compressibility along with the associated lateral stresses were measured in a compressionmeter-type ring chamber that was built specially for this study. The effect of method of compaction on the compressibility was studied by preparing samples by pluviation and by vibratory compaction. Vibratory compaction produces samples that are less compressible than pluviated samples. However, if vibratory compaction is continued beyond the point at which a sample achieves 100 per cent relative density, then the compressibility of such a sample increases. It appears that if vibration is continued beyond some optimum time period, the grain structure begins to lose rigidity due to the very same vibratory action that produced it.

Lunar soils are composed of somewhat elongated grains many of which are angular. Several distinct layers have been identified in the core tubes brought back by the various Apollo missions. Studies of grain orientation have indicated that some of these layers also differ in the preferred orientations of the long axes of grains. Since these changes in stratigraphy were also detected by penetration resistance tests on the lunar surface, it can be concluded that at least qualitative relationships exist between the fabric and mechanical properties of lunar soils in-situ.

"The Influence of Gravity, Prestress, Compressibility and Layering on Soil Resistance to Static Penetration," by D. D. Treadwell (1974) Dissertation submitted in partial fulfillment for degree of Doctor of Philosophy, Department of Civil Engineering, University of California, Berkeley.

ABSTRACT

The results of model tests have been used to quantify the effects of gravity variations, soil prestress and compressibility, and soil layering on soil resistance to static penetration. Dimensional analysis of classical bearing capacity and penetration resistance theories provides a means for the comparison of actual and predicted results.

A new method (submergence) has been developed which enables the simulation of reduced gravity in laboratory soil deposits on earth. Test results obtained using the submergence technique agree remarkably well with theoretical predictions. Variations in penetrometer base dimension have been shown to have the same proportional influence on penetration resistance as gravity variations, at least for relatively incompressible cohesionless soils.

The failure mechanism and theory developed by Durgunoglu and Mitchell in 1973 has been shown to accurately predict penetration resistance over a wide range of relative depth. Knowledge of the relative influence of soil compressibility and prestress, while still uncertain, has been improved by experimentation and the evaluation of data from the literature.

Soil deposits containing layers carefully prepared at different densities have been extensively tested to determine the influence of density variations on the interpretation of static penetration data. The shape and magnitude of the penetration resistance curve in the transition

zone between a dense and loose layer, for instance, has been shown to be related to penetrometer size as well as the density difference between successive layers. Conservative procedures for the interpretation of test data obtained in layered deposits have been proposed.

Lastly, guidelines and comments on the use of the static penetration test and the utility and accuracy of the data obtained are presented, based on the experimentation performed during this study and an extensive review of the literature. It is concluded that the static penetration test and the resultant data should not be used as the sole source of subsurface information but as a valuable part of a comprehensive geotechnical investigation program.

"Determination of In-Situ Soil Properties Utilizing an Impact Penetrometer," by J. B. Thompson and J. K. Mitchell (1973) Research just completed, not yet submitted for publication.

INTRODUCTION

The purpose of this study has been to investigate the response of soil targets to impact penetrometers in order to evaluate their possible use as remote sensors for determining the properties of soil deposits. Impact penetration of soil targets has received considerable attention over the last decade. The primary goals of these past investigations have been to: 1) evaluate impact penetrometers as tools for determining in situ soil properties, and 2) predict the resistance to impact penetration a given soil deposit would offer. Large quantities of qualitative knowledge and experimental data have resulted from these previous investigations. Unfortunately, such factors as the lack of control of the properties of the soils tested, large variations in the shapes and sizes of penetrometers used, and limitations on the variables evaluated, have made it difficult to generalize the experimental data gathered in these investigations. Particularly lacking are data on the effects of soil properties on the response of an impact penetrometer.

In addition to the qualitative knowledge provided by these previous investigations, several theoretical and empirical quantitative relationships have resulted. These quantitative relationships have usually been expressed in terms of some dependent variable describing the penetration problem and variables describing the penetrometer and its impact velocity. Existing quantitative relationships are generally of limited usefulness in attempting to predict the characteristics of the soil impacted because commonly used soil properties are not included specifically.

Perhaps the main factor that has limited the use of the impact penetrometer in the past and has made it difficult to correlate the data obtained by previous investigators is the lack of a satisfactory theoretical or quasi-theoretical solution to the problem. Several attempts have been made to find such a solution, but as yet none has proved adequate.

After carefully reviewing the state-of-the-art of impact penetration of soils, it was concluded that an experimental program should be designed and conducted which would supply data on the effects of soil characteristics on the response of a soil target to an impact penetrometer and would provide a basis for the development of the needed quantitative relationships. These experiments have been conducted, and the analysis which has been completed is presented below.

As the complete results of this investigation are not yet available (a doctoral dissertation is nearing completion), the study is described in some detail herein.

SOIL TESTED

The soil tested in this experimental program was a clean, dry beach sand from near Monterey, California. Only one soil was tested because it was felt that an attempt should first be made to solve the impact penetration problem for one soil before the more difficult problem of solving it for all soils is considered. Considerable variations in the properties of the soil target were achieved by depositing the soil at different densities. The principle characteristics and mechanical properties of this soil follow.

A. Mineralogy and Particle Shape - The sand tested was composed

almost entirely of quartz. Small amounts of feldspar and mica were also present. The individual sand grains were predominantly sub-rounded.

- B. Specific Gravity - The specific gravity of the sand was 2.65.
- C. Grain Size Distribution and Classification - The grain size distribution curve for this sand is shown in Fig. 1. The average particle diameter, D_{50} , taken from the grain size distribution curve is 0.395 mm. The soil classifies as a medium sand according to the MIT Classification System. It should be noted that the processing of the sand during testing had little effect on its grain size distribution curve.
- D. Minimum and Maximum Void Ratio and Air-Dry Density - The minimum void ratio and maximum air-dry density for this sand were 0.551 and 106.5 pcf, respectively. The maximum void ratio and minimum air-dry density were 0.859 and 88.8 pcf, respectively, as determined by standard tests.
- E. Soil Angle of Internal Friction - The variation in the angle of internal friction of this sand with void ratio and confining pressure, σ_3 , applied is shown in Fig. 2. The variation of the angle of internal friction with the relative density of the sand is also indicated.

A portion of this same beach sand was dyed black with a carbon tetrachloride soluble dye for use in two impact tests conducted to investigate the mechanisms by which impact penetration occurs. The amount of dye placed on the individual sand grains was minimized, and it is believed that the presence of the dye had little effect on the mechanical properties of the sand. Both the dyed and the undyed sand had essentially the same grain size distribution curves.

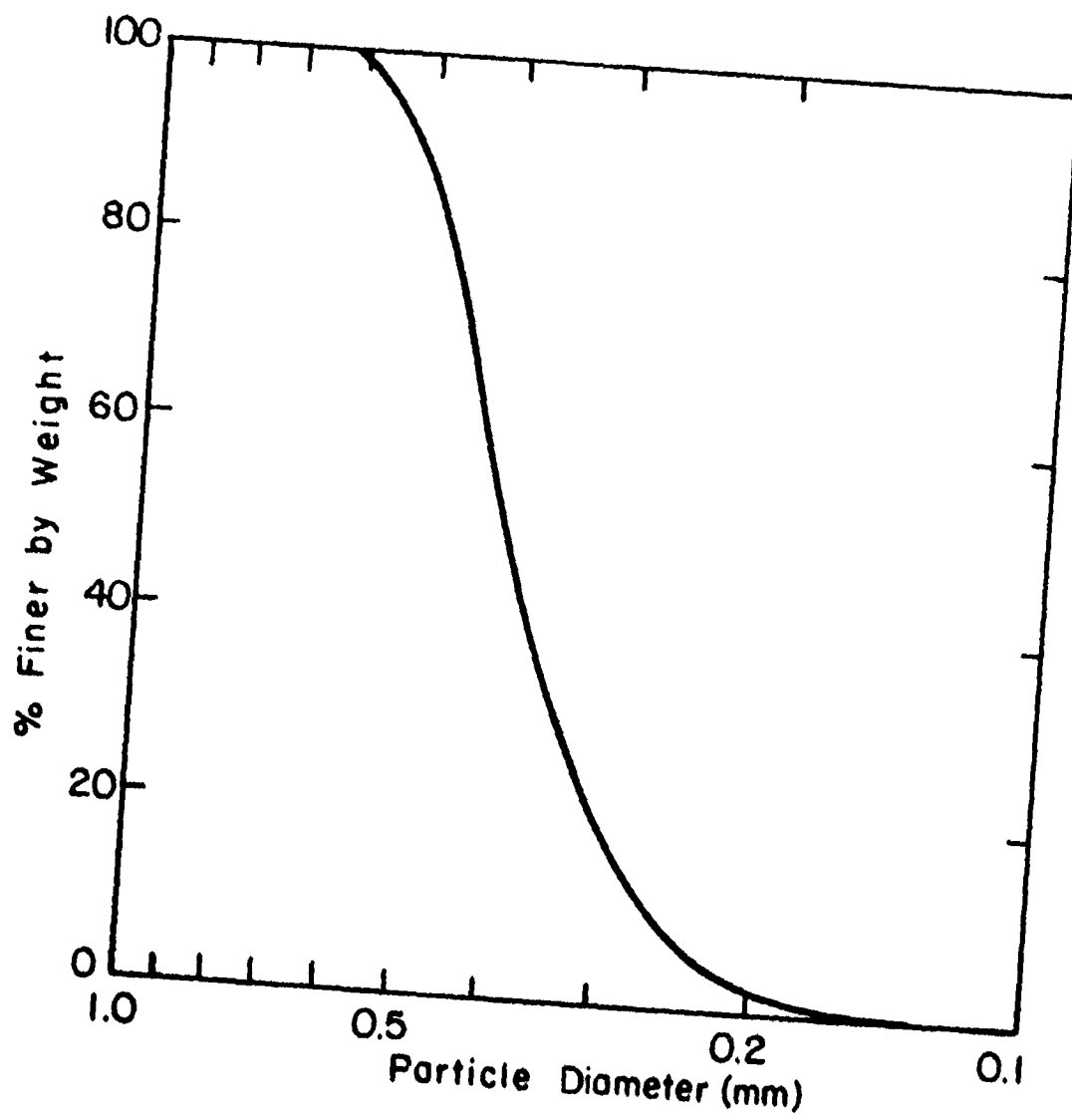

FIG. 1 GRAIN SIZE DISTRIBUTION CURVE

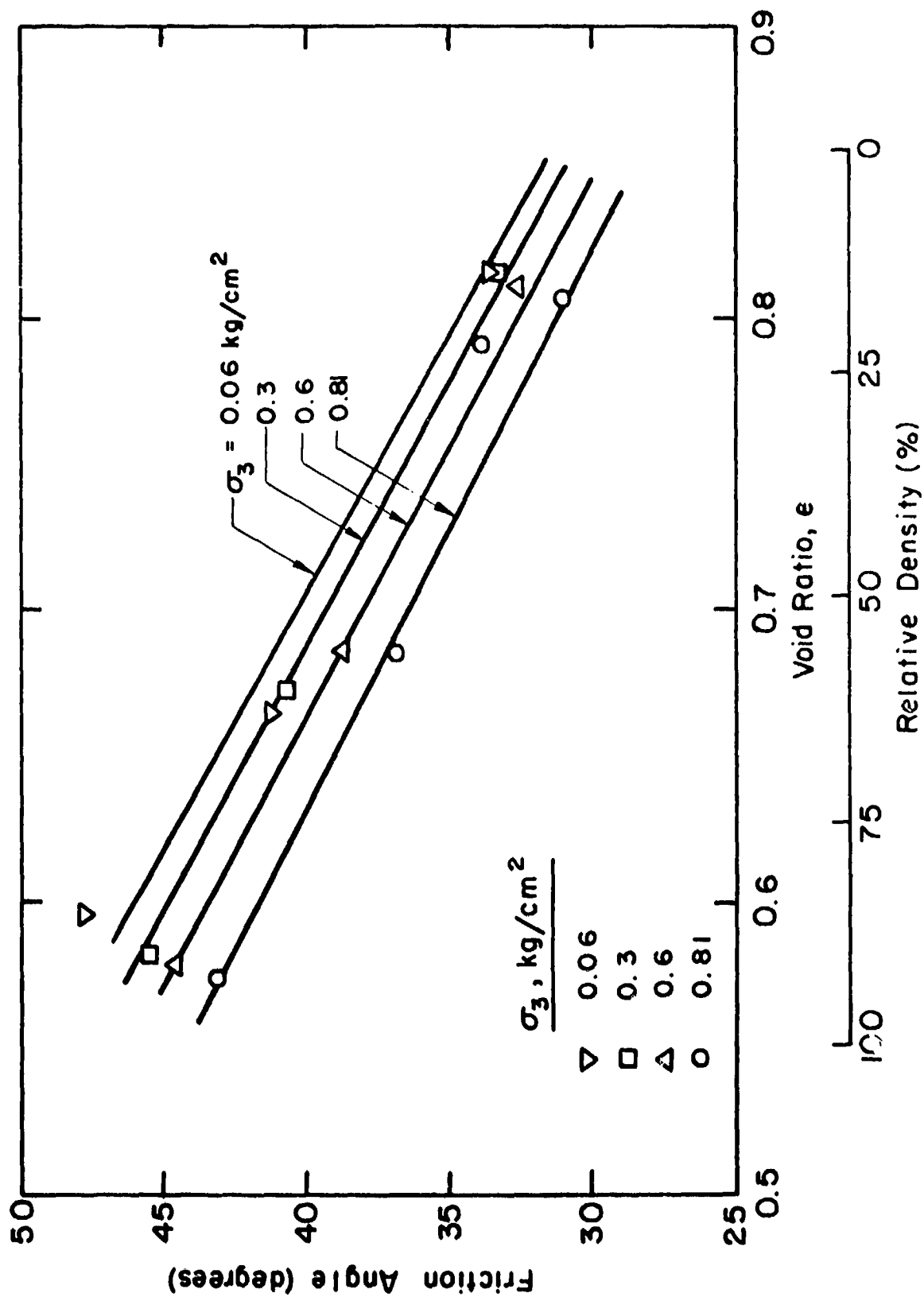

FIG. 2 SOIL ANGLE OF INTERNAL FRICTION

TARGET CONSTRUCTION

Loose, medium, and dense sand targets were tested in this experimental program. Prior to conducting the impact penetration tests, methods of constructing targets at these densities had to be developed. The methods described below were selected as the best available, and a thorough check of the uniformity of the targets with depth was performed. All targets were believed to be uniform in density within approximately 1 pcf.

- A. Loose Targets - The loose targets were constructed by pluviation (free fall of the sand grains). In order to produce the loosest target possible, the height of drop of the sand was minimized by slowly pulling a sieve through the deposit of sand. This technique produced targets at a relative density of approximately 11%.
- B. Medium Targets - Medium dense targets were also constructed by pluviation. In this case however, a drop height of approximately 9 inches was maintained and the rate of flow held constant by a screen placed 9 inches above the existing surface of the sand deposit. The screen was coarse enough to pass the sand grains but fine enough to act as a control on the rate at which the sand passed through it. Because it proved too costly to construct a device to continuously maintain a constant height of drop, the medium dense targets had to be built in thin layers. Some scatter in the experimental data may have resulted from this difficulty. Targets at a relative density of approximately 63% were produced by this technique.

C. Dense Targets - The dense targets were constructed by vibrating lifts of sand placed in the target box. By experimentation, it was found that the dense targets could be constructed at the maximum density achievable and in a minimum amount of time by using 6" lifts vibrated for 15 minutes each. Each lift was vibrated using a cap vibrator covering the entire surface area of the lift. This method of construction produced targets at a relative density of approximately 98%.

Two targets, one loose and one dense, were specially constructed for use in investigating the mechanisms by which impact penetration occurs. The procedures followed in constructing these targets were essentially the same as those described above except that horizontal layers of dyed sand were placed at regular intervals within the soil target. As will be mentioned later, some difficulty was encountered in constructing the dense soil target, and as a result, distortion of the supposedly horizontal dyed sand layers occurred during target construction. Fortunately, this distortion did not significantly hinder the interpretation of the impact test conducted in this target.

EXPERIMENTAL EQUIPMENT

Experimental equipment had to be designed and fabricated to conduct tests under both atmospheric and vacuum conditions. Tests in vacuum were needed to simulate conditions on the lunar surface. The equipment layout used in conducting the atmospheric impact tests is shown in Fig. 3. A similar layout was used for conducting the impact tests under vacuum conditions except that the gun barrel exited into a closed speed trap, vacuum chamber system. The target, of course, was placed in the vacuum chamber. Major equipment used in conducting both series of tests included:

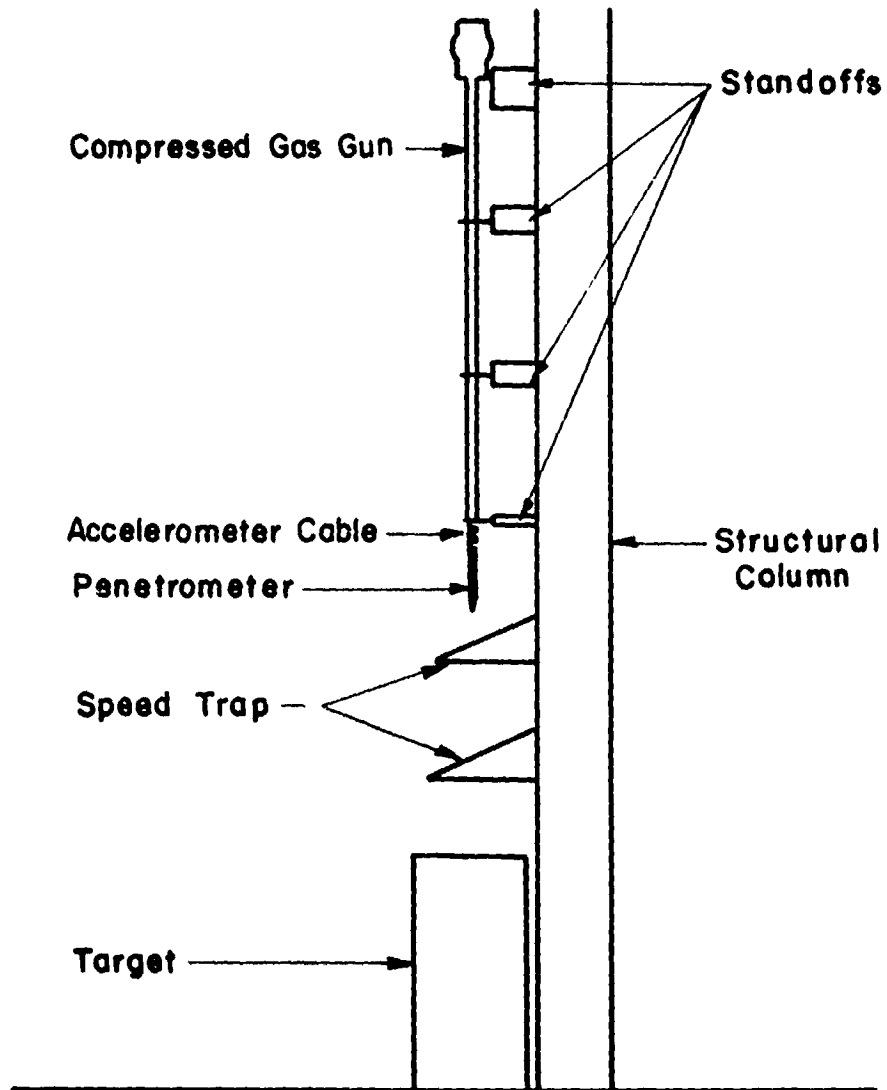

FIG. 3 EXPERIMENTAL EQUIPMENT LAYOUT (ATMOSPHERIC TESTS)

- A. A Compressed Gas Gun - The compressed gas gun was used to propel the penetrometer to the desired impact velocity. It consisted of a pressure vessel and a gun barrel. The gas used was compressed nitrogen.
- B. A Speed Trap - In the atmospheric impact tests, the speed trap was composed of two photocells at known positions along the flight path of the penetrometer. Phototubes replaced the photocells in the vacuum impact tests. An oscilloscope was used to record the photocell/phototube output.
- C. A Target Box - The target box was constructed from aluminum reinforced plywood. It was 30 x 30 inches square and approximately 60 inches deep. A special feature of the target box was that one side was removable to allow excavation of the target. Target excavation was performed in order to study the internal deformations caused by the impact penetrometer.
- D. A Penetrometer - The penetrometer used was a cone tipped cylindrical penetrometer approximately 18 inches long and 1.5 inches in diameter weighing 6.1 pounds. The nose was 2.77 inches long. An accelerometer was mounted near the nose of the penetrometer and a cavity was cut in the rear of the penetrometer to contain the low noise coaxial cable used to conduct the accelerometer signal to the recording device. The cable was coiled in this cavity prior to firing the penetrometer.
- E. An Accelerometer and Accessories - A Kistler Piezotron accelerometer and its necessary accessories were used to record the resistance offered by the soil target to impact penetration. The output from the accelerometer was recorded on an oscilloscope.

F. A Vacuum Chamber - Through the cooperation of Mr. D. V. Gault, arrangements were made to utilize an existing vacuum chamber located at the NASA Ames Research Center, Moffett Field, California. The vacuum chamber was approximately 6 feet in diameter and 9 feet high and easily contained the target box. A phototube speed trap available at the Ames facility was also utilized. Considerable assistance was provided by Mr. J. Wedekind of Ames in the performance of these vacuum tests.

G. Target Construction and Transportation Equipment - Target construction and transportation equipment used included several screens, a vibrator, a fork lift, a crane, a chain hoist, a platform scale, etc. Most of this equipment was available at the test sites prior to performing these tests.

The general sequence followed in conducting an impact penetration test was to: 1) construct the target, 2) transport the target to its test location (targets built for the vacuum tests were not transported), 3) insert the penetrometer in the gas gun, 4) draw a vacuum on the target, if applicable, 5) fire the penetrometer and record its acceleration-time trace, and 6) measure the deformation produced in the soil target by the penetrometer. The data gathered from these tests are presented and discussed in the following sections.

DEPENDENT AND INDEPENDENT VARIABLES

In the design of the experimental program conducted in this investigation, several dependent and independent variables were considered for study. Independent variables selected included the target density,

the pre-impact air pressure within the soil target, and the penetrometer impact velocity. The target density was selected as an independent variable because the primary purpose of this investigation was to evaluate the use of impact penetrometers for predicting soil target properties and because the properties of the soil tested, a dry sand, can be related directly to its density. Also, data is generally lacking on the effect of soil target properties on the response of soil targets to impact penetrometers.

Pre-impact air pressures in the soil target were varied to provide data on the effects of pore air pressures developed in the soil target during impact penetration. Some previous investigators have stated that these pore air pressures significantly influence the penetration process. Data available from previous investigations are very limited, and this lack has hindered the development of quasi-theoretical solutions to the problem and the extrapolation of terrestrial test results to extra-terrestrial environments. In this experimental program, a series of impact tests were conducted in which these effects were present, and a series of tests was conducted in which these effects were essentially completely absent due to the removal of the air from the soil pores.

The penetrometer impact velocity was selected as the third independent variable because it was felt that the influence of the two above independent variables might be impact velocity dependent.

The dependent variables recorded during and after each impact penetration test were the dimensions and volumes of the craters formed, the depth of penetration of the penetrometer into the soil target, and the instantaneous resistance offered by the soil target to the impact penetrometer. These are the dependent variables which could be reasonably

measured in full scale field impact penetration tests. In two special impact tests, the deformations produced internal to the soil target were also recorded.

The relationships between these dependent and independent variables derived from this experimental program are presented in the following sections. Each section is prefaced by a state-of-the-art review of existing knowledge concerning each dependent variable. A list of the references used in the preparation of these reviews, as well as the main points made in each of these references, can be found in Thompson and Mitchell (1972).

DEFORMATION OF THE SOIL TARGET

The deformation produced in a soil target by an impact penetrometer is of interest, because these deformations may be indicative of the properties of the target. Generally speaking, it would only be practical in conducting full scale field impact penetration tests to measure the surficial deformations of the target. However, in the state-of-the-art review which follows and in the experimental program conducted in this study, internal deformations are also of interest because they aid in developing an understanding for the process by which impact penetration occurs. Before presenting and discussing the data obtained in this study, existing qualitative and quantitative knowledge of the deformations produced in a soil target by an impact penetrometer will be reviewed.

The available qualitative knowledge on the deformation of the soil target can be summarized as follows:

A. Effect of Penetrometer Characteristics

1. The penetrometer material is not of primary importance.

2. A soil nose which is generally conical in shape tends to form on blunt, hemispherical penetrometers. The soil nose does not form on penetrometers having a sharp tip. Instead, ablation of the penetrometer frequently occurs.
- B. Effect of Penetrometer Pre-Impact Flight Characteristics
1. An increase in impact velocity will produce an increase in crater volume and an increase in the amount of soil comminuted during penetration.
- C. Effect of Soil Target Characteristics
1. Penetration can occur by both shearing and compaction of the target soil.
 2. Penetration by soil compaction occurs in loose sands or inefficiently packed soils.
 3. Penetration by soil shearing occurs in efficiently packed soils such as dense sands. Plastic fields are mobilized and large soil wedges are moved laterally.
 4. Soil comminution occurs in sands and gravels but not in silt and clay soil targets.
- D. General Observations
1. Instantaneous and final crater shapes differ.
 2. Surface cracking has been observed in some soil targets. The cracking pattern is frequently a radial one.
 3. In some cases, soil was observed to be firmly stuck to the penetrometer following penetration.
 4. Drawdown of the soil around the penetrometer has been noticed.

Quantitative relationships developed by previous investigators have been restricted to expressions for the volume of the crater formed as a function of the impact velocity and the penetrometer mass. These relationships are:

- A. Crater Volume Versus Impact Velocity - All available relationships are of the following form:

$$\text{Vol.} = KV_0^N \quad (1)$$

where: Vol. - crater volume

K, N - constants

The values for the constant, N, reported by others have varied between 1 and 3.

- B. Crater Volume Versus Penetrometer Mass - All available relationships are of the form:

$$\text{Vol.} = CM^X \quad (2)$$

where: M - penetrometer mass

C, X - constants

Reported values for X have ranged from 0 to 1.

Surficial deformations of soil targets which could be measured in full scale field penetration tests include the crater diameter, the crater depth, and the crater volume produced by the impact penetrometer. Data obtained on the effects of target density, pre-impact air pressure within the soil target, and impact velocity on the crater diameters recorded in this investigation are presented in Fig. 4. These data indicate that there is only a slight tendency for the crater diameter to increase with a decrease in the density of the target. This lack of sensitivity suggests that for the sand tested, the diameter of the crater created during impact

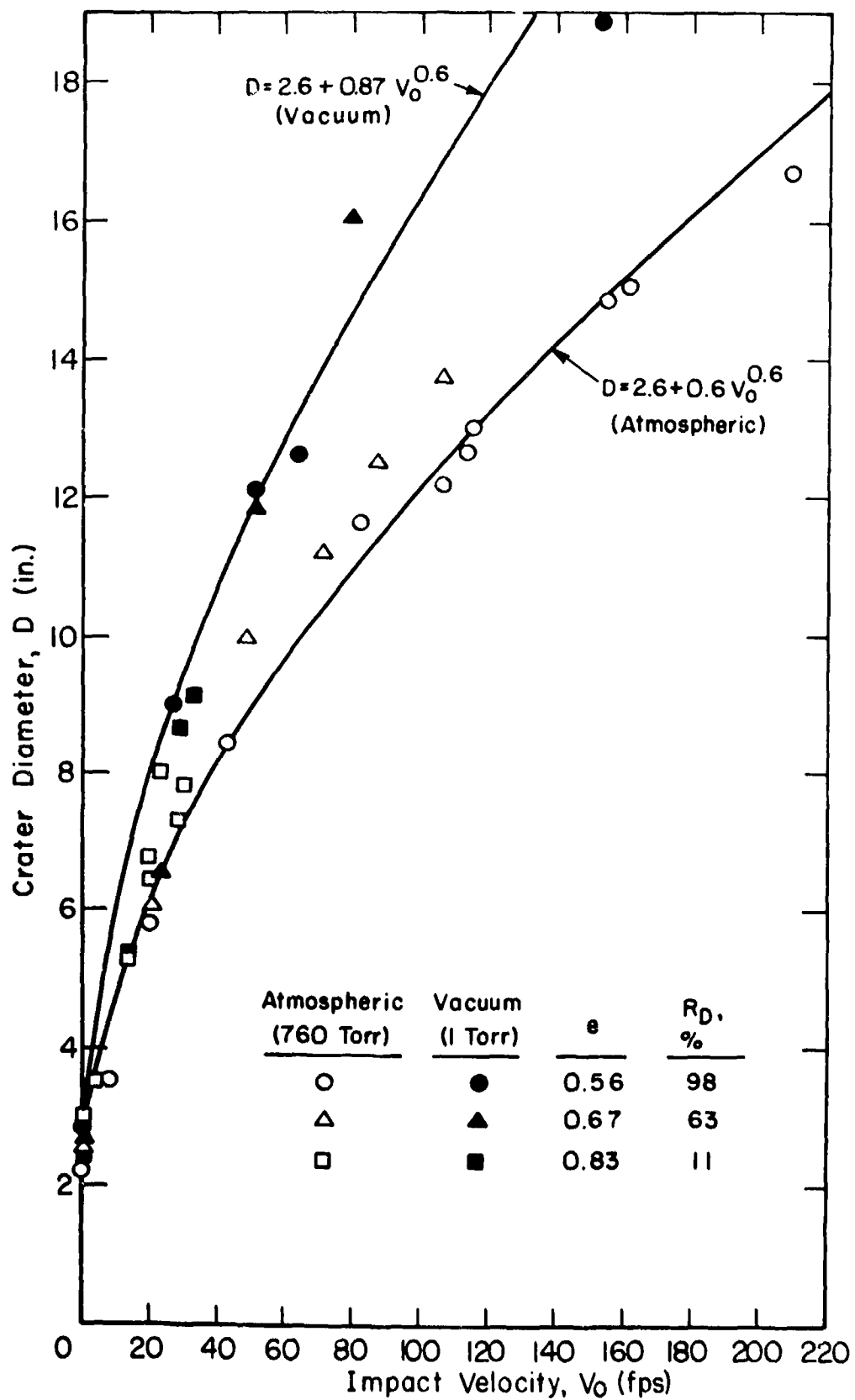

FIG. 4 CRATER DIAMETER

penetration cannot, in general, be used as a measure of the properties of the soil target impacted. As shown in Fig. 4, the crater diameter increases with an increase in the impact velocity and with a decrease in the pre-impact air pressure within the soil target. Two equations which reasonably fit the crater diameter data obtained at the two air pressure conditions tested are given in Fig. 4.

The data obtained on crater depth (measured from the rim to the bottom of the crater) are presented in Fig. 5. This crater dimension also appears to be very insensitive to the soil target properties. The depth of the crater also appears to be insensitive to the pre-impact air pressure within the soil target but does increase with an increase in the impact velocity. The equation shown in Fig. 5 best fits the data obtained.

Crater volume data are presented in Fig. 6. The volume of the crater created is seen to increase with an increase in the impact velocity and a decrease in the pre-impact air pressure within the soil target. The crater volume appears to be essentially independent of the density of the soil target. Two equations are presented in Fig. 6 which best represent this crater volume data for the two air pressure conditions tested.

Apparently, then, the dimensions and volumes of the craters recorded in this experimental program are not indicative of the properties of the soil targets tested. This statement, of course, may not be valid at higher impact velocities, for greater variations between the properties of the soil targets, or for different soil types. However, it is felt that even in these cases, crater characteristics would yield only a gross estimate of the properties of the target. In general, it is not recommended that

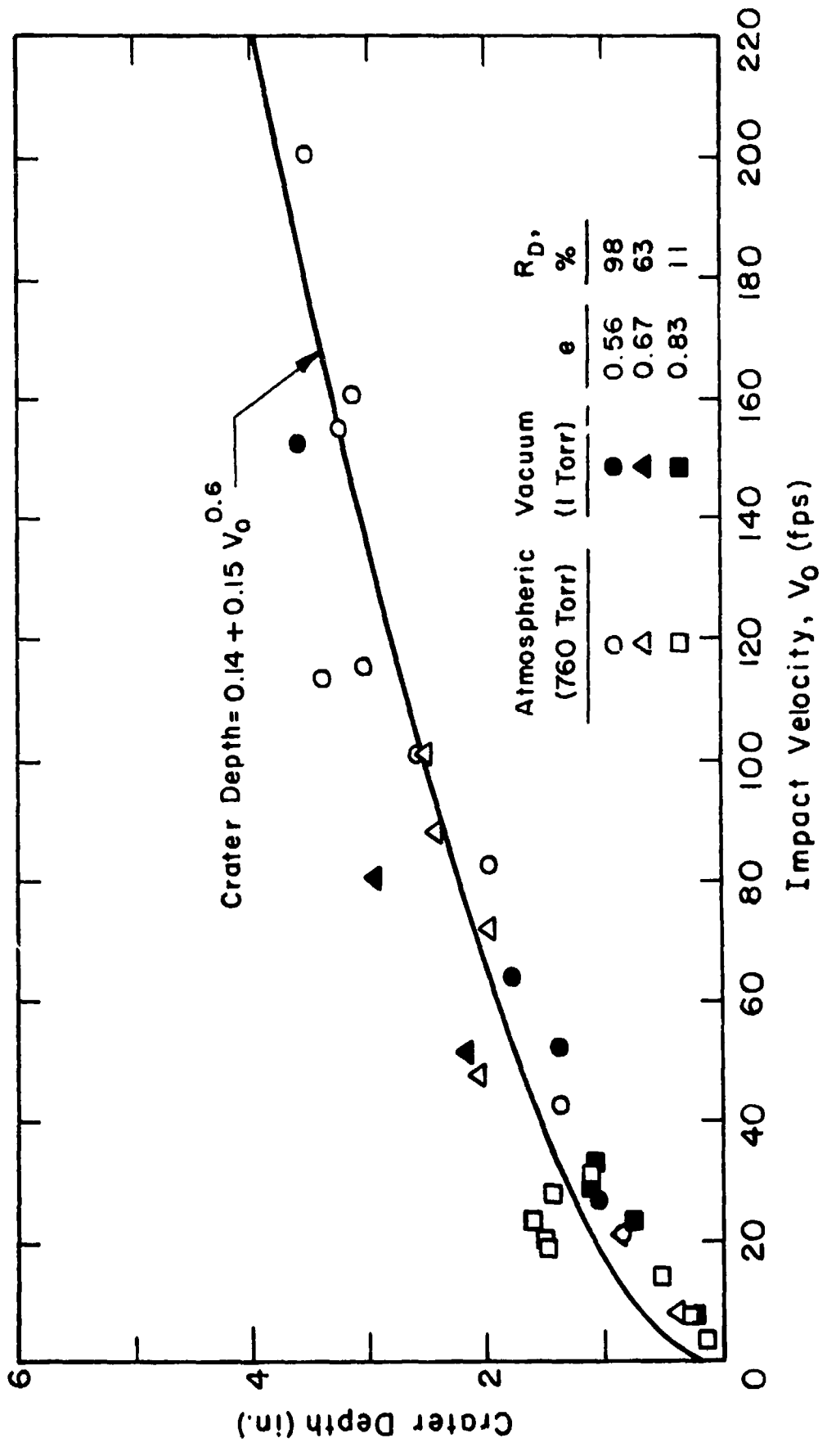

FIG. 5 CRATER DEPTH

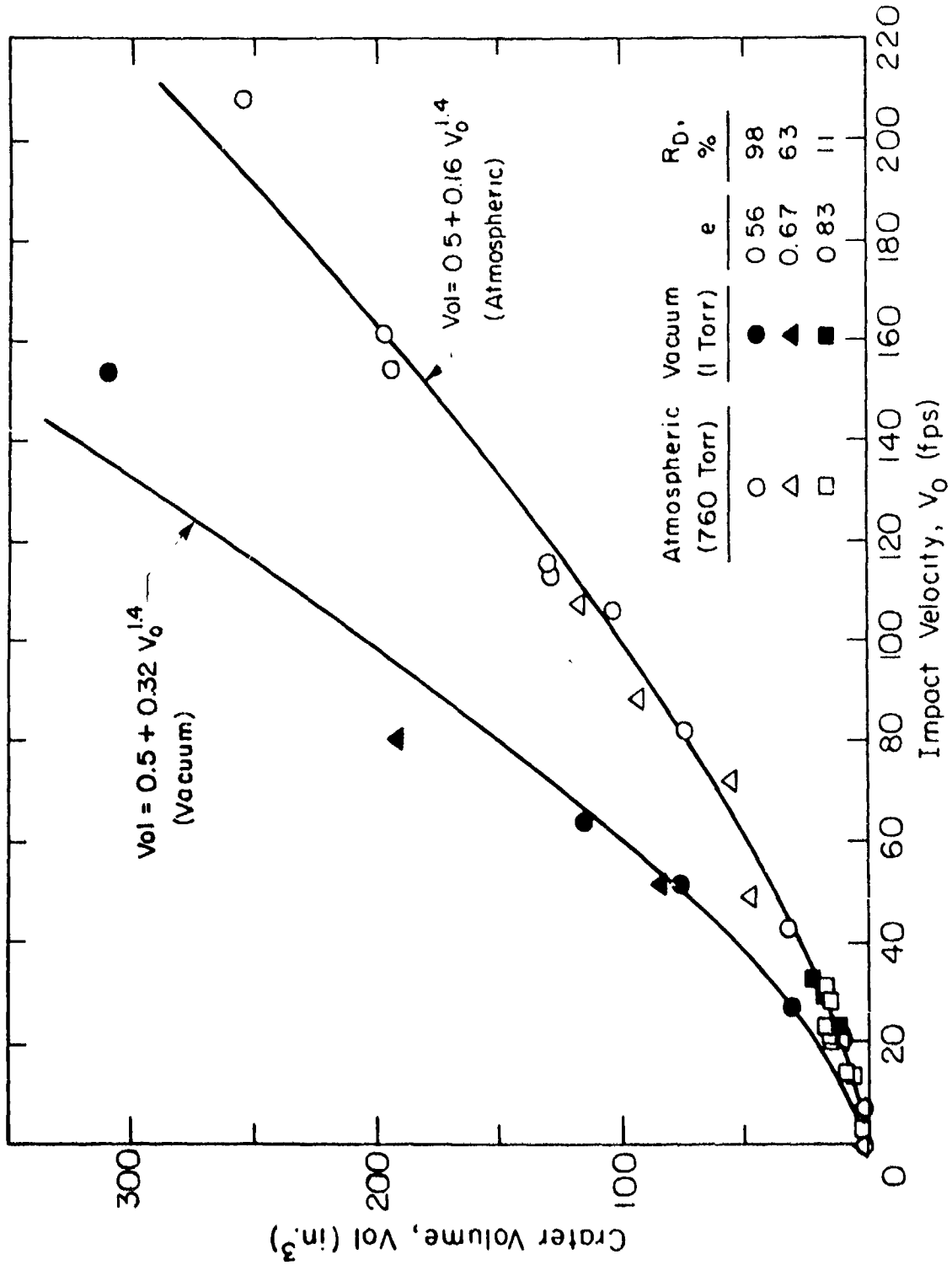

FIG. 6 CRATER VOLUME

crater characteristics be used in an attempt to evaluate the properties of cohesionless soil targets.

A major handicap to the development of a quasi theoretical solution to the impact penetration problem has been a lack of understanding for the process by which impact penetration occurs. Penetration models which have been used to represent the penetration process have varied from fluid-like models to models in which portions of the soil mass move as rigid bodies. In an attempt to provide information on the actual mechanism by which impact penetration takes place, two impact tests were conducted in which the deformations produced internal to the soil target were determined. The tests were conducted in one loose target ($\gamma = 91.7$ pcf) and in one dense target ($\gamma = 107.0$ pcf). The internal deformations were determined by 1) constructing targets in which horizontal layers of dyed sand were placed at known intervals, 2) conducting the impact penetration tests in the usual manner, 3) tilting the initially vertical box on its side (the initially horizontal layers of sand were now vertical), 4) removing one face of the target box, and 5) excavating into the target. These internal deformations are shown in Fig. 7 and Fig. 8 which are photographs of surfaces excavated in the loose and dense targets respectively. In each figure the uppermost dark line represents the initial target surface. The light soil above this line was placed as backfill in order to permit the rotation of the target box onto its side.

The deformations produced in the loose target, Fig. 7, are limited to a narrow zone immediately surrounding the penetrometer. Predominantly, the soil has been moved downwards and outwards, and penetration seems to have resulted from the compression of the soil in the path of and immediately adjacent to the penetrometer. Considerable downdrag of the initially

REPRODUCIBILITY OF THE
ORIGINAL PAPER



FIG. 7 INTERNAL SOIL TARGET DEFORMATIONS (LOOSE TARGET, $\gamma = 91.7$ PCF)

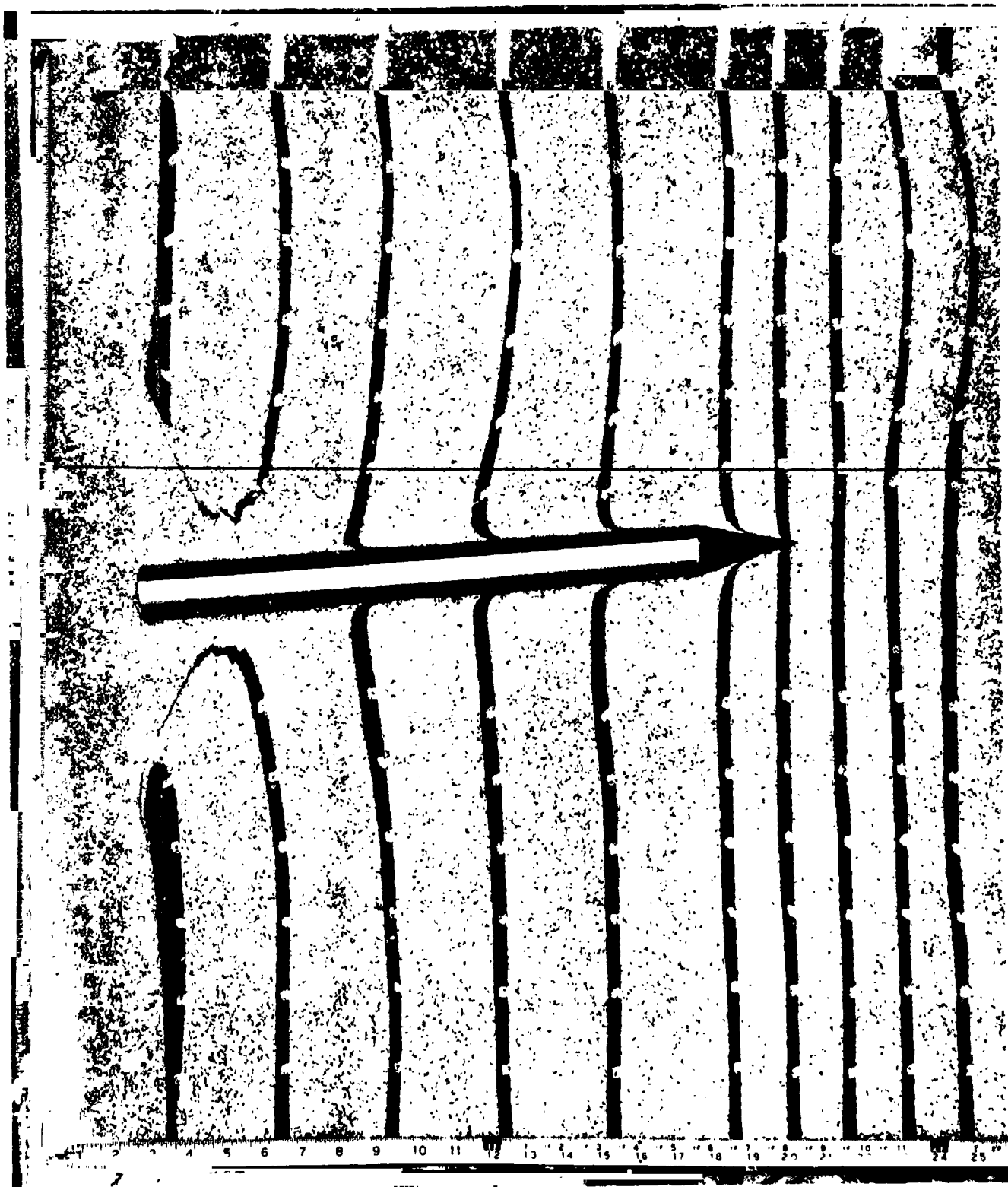

FIG. 8 INTERNAL SOIL TARGET DEFORMATIONS (DENSE TARGET, $\gamma = 107$ PCF)

horizontal dark layers has occurred. It is important to note that the mechanism of penetration is not at all similar to the classical "general shear mechanism" upon which most existing theoretical solutions to the bearing capacity problem are based. Instead the deformations produced in this loose target suggest that a "local shear" approach to the problem would be more valid.

Deformations in the dense soil target, Fig. 6, are more extensive than in the loose target. Unfortunately, some of the deformations indicated in the figure were produced during the construction of the target as the supposedly horizontal dark sand layers were distorted by the cap vibrator. The deformations produced during target construction appear as "waves" in the dark sand layers. Nevertheless, the deformations produced by the penetrometer can be satisfactorily observed. Movement of the soil in the dense target is generally outwards and upwards. Downdrag of the soil does, however, occur in the immediate vicinity of the penetrometer. Although no shear planes can be observed passing through the lower dark sand layers, the deformation produced in this soil target does show a slight resemblance to the classical "general shear mechanism". An interesting feature shown in Fig. 8 is the folding over of an upper layer which has occurred during crater formation.

In summary, these two deformation study tests indicate that the zone of soil affected by the impact penetrometer varies with the density of the soil target and that the same model for the penetration process might not be expected to apply to all soil densities. Furthermore, it is likely that classical solutions to the bearing capacity problem of soils will require modification before they can be applied to the impact penetration problem.

DEPTH OF PENETRATION

The depth to which an impact penetrometer will penetrate a soil target has received the most study of any phase of this problem in the past. It is the only dependent variable whose value has been related quantitatively in some manner to the characteristics of the soil target. Existing knowledge on this dependent variable is presented first before the data obtained in this experimental program are discussed.

Qualitative relationships which have been obtained from previous investigations include:

A. Effect of Penetrometer Characteristics

1. An increase in penetrometer weight will produce an increase in the depth of penetration.
2. An increase in penetrometer nose sharpness generally will produce an increase in the depth of penetration.
3. A decrease in penetrometer surface roughness will produce an increase in the depth of penetration.
4. A decrease in penetrometer diameter will produce an increase in the depth of penetration.

B. Effect of Penetrometer Pre-Impact Flight Characteristics

1. An increase in impact velocity will produce an increase in the depth of penetration.
2. A decrease in the impact angle will produce an increase in the depth of penetration (perpendicular impact corresponds to an impact angle of 0°).

C. Effect of Soil Target Characteristics

1. An increase in the static bearing strength of the soil target will produce a decrease in the depth of penetration.

2. An increase in the density of the soil target will produce a decrease in the depth of penetration.
- D. Effect of the Pre-Impact Air Pressure Within the Soil Target
1. If the soil deposit tends to dilate when penetrated, a decrease in the pre-impact air pressure will produce an increase in the depth of penetration.
 2. If the soil deposit tends to compress when penetrated, a decrease in the pre-impact air pressure will produce a decrease in the depth of penetration.
 3. Apparently there is a certain pre-impact air pressure above which the influence of the magnitude of air pressure is negligible on the depth of penetration.

The quantitative relationships which have been derived from previous experimental programs relate depth of penetration to impact velocity, penetrometer mass, and penetrometer dimensions. These relationships are summarized below.

- A. Depth of Penetration Versus Impact Velocity - All available relationships can be summarized by the following two equations:

$$P = KV_0^N + B \quad (3)$$

$$P = C \ln (1 + 2 \times 10^{-5} V_0^2) \quad (4)$$

where: P - depth of penetration
 V_0 - impact of velocity
 K,B,N,C, - constants

Equation 3 is of the form proposed by most previous investigators. Equation 4 was proposed by Young (1969) and is presented because it is based on a large amount of experimental data and

because it has found considerable use recently. The value for the constant, N, in Equation 3 proposed by previous investigators has varied between 0.67 and 1.5. The value for this constant and the others appearing in the two equations is believed to be a function of such variables as penetrometer and target characteristics. Several attempts have been made to relate these constants to common engineering soil properties, but they have not been successful.

- B. Depth of Penetration Versus Penetrometer Mass - All available relationships can be summarized by the following equation:

$$P = KM^X \quad (5)$$

where: M - penetrometer mass

K, X - constants

Reported values for X have varied between 0.5 and 1.0.

- C. Depth of Penetration Versus Penetrometer Dimensions - All relationships of this type relate the depth of penetration to the penetrometer diameter and can be summarized by the following equation:

$$P = \frac{K}{D^Y} \quad (6)$$

Values of Y derived from previous studies have varied between 1 and 2.

It should be noted that the above quantitative relationships have been derived from tests using penetrometers varying from spheres to blunt tipped, long, right circular cylinders. No clear distinctions between these various types of penetrometers could be found when summarizing the values for the constants presented above.

The experimental program in this study was conducted in part to investigate the effects of various variables on the depth of penetration. The data gathered in this program are summarized in Fig. 9, which is a plot of depth of penetration versus impact velocity. Observations made from this figure are:

1. Effect of Pre-Impact Air Pressure Within the Soil Target - Within the range in variables investigated, the pre-impact air pressure in the soil target had essentially no effect on the depth of penetration. Although there were some small differences between the tests conducted at 760 Torr and 1 Torr, all differences were well within the scatter of the data observed.
2. Effect of Target Characteristics - As shown in Fig. 9, the density of the target has a significant effect on the depth of penetration. An increase in target density yields a decrease in the depth of penetration.
3. Effect of Impact Velocity - An increase in the impact velocity yields an increase in the depth of penetration.

Various equations were examined to find the one that best fit the data acquired in this testing program. Included in these equations were those proposed by previous investigators. It was found that Equation 3,

$$P = KV_0^N + B \quad (3)$$

best fit the data obtained. The equation suggested by Young (1969), Equation 4, proved to be inadequate. It was found that the value for the constant K in Equation (3) was 0.14 and was independent of the density of the target as well as the pre-impact air pressure in the soil target.

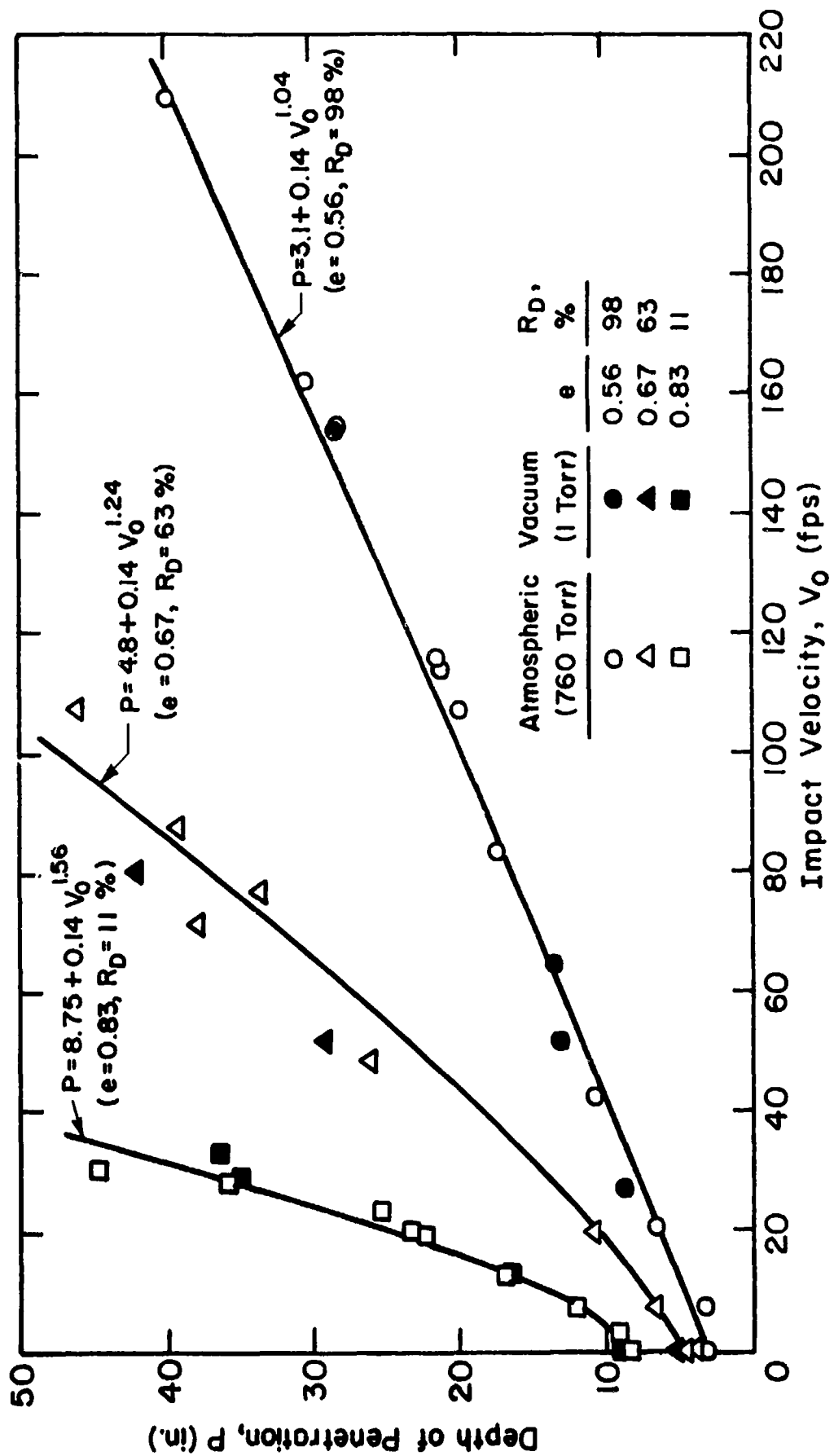

FIG. 9 DEPTH OF PENETRATION

The constant, N, was found to vary linearly with the target air-dry density as:

$$N = 4.5 - 0.033\gamma$$

where: γ - target air-dry density (pcf).

An additional relationship for N was derived relating N to the relative density of the target. This relationship was derived because the behavior of granular soils is frequently expressed in terms of relative density and because there are existing relationships between the relative density of a granular material and its other characteristics. The constant, N, was found to vary linearly with the relative density of the target as:

$$N = 1.62 - 5.9 \times 10^{-3} R_D \quad (8)$$

where: R_D - relative density of the target (%).

Values for the constant, B, were found to vary approximately linearly with the density of the soil target and with the relative density of the target.

$$B = 28.5 - 0.22\gamma \quad (9)$$

$$B = 9.25 - 0.065 R_D$$

The values for N and B for the three target densities tested are shown in Fig. 9. Additional study will be performed to verify the form of the above proposed equation and to evaluate the meaning and values of the constants appearing in the equation. It should be noted that the depth of penetration appears to be a sensitive indicator of the characteristics of the soil target.

SOIL TARGET RESISTANCE

The analysis of the data obtained in this experimental program on the resistance offered by a soil target to an impact penetrometer is incomplete at this writing. Work is progressing on this analysis, and the results obtained will be supplied upon completion. Indications to date are that the soil resistance is highly dependent on the density of the target tested.

CONCLUSION

Although work is still progressing on the analysis of the data obtained in this experimental program, two primary conclusions may be made at this time: 1) the dimensions and volumes of the craters produced by an impact penetrometer in this study are not sufficiently sensitive to the characteristics of the soil targets to be used as indicators of these characteristics, and 2) the depth of penetration of the penetrometer is highly sensitive to the characteristics of the soil target and may be used as an indicator of these characteristics. A preliminary set of equations based on the data obtained in this program has been presented for this purpose.

REFERENCES

1. Thompson, J. B. and Mitchell, J. K. (1972) "Soil Property Determination by Impact Penetrometer," Conference on Rapid Penetration of Terrestrial Materials, Texas A & M University, College Station, Texas, February, pp. 361-388.
2. Young, C. W. (1969) "Depth Prediction for Earth-Penetrating Projectiles," Journal of the Soil Mechanics and Foundations Division, Proceedings of the American Society of Civil Engineers, Vol. 95, No. SM3, May.

"Effect of Gradation on Lunar Soil Response to Loading," by W. N. Houston and C. S. Chang (1974) Phase Report on work under NASA Grant NGR 05-003-406, Science Sciences Laboratory Series 15, Issue 6, in press.

ABSTRACT

Considerable utilization has been made of data derived from lunar soil simulants, particularly the UCB Lunar Soil Simulant No. 2. Relationships between porosity and expected deformability for actual lunar soil have been derived from theoretical and empirical studies of LSS No. 2. These relationships made possible the use of astronaut footprints as plate load tests and led to the statistical characterization of porosity for the upper 15 cm of lunar surface. When the lunar soil and the lunar soil simulant (LSS No. 2) exhibited the same resistance to compression and penetration, the average porosity of the lunar soil simulant was found to be about 43.5 to 44%, and the standard deviation was found to be about 2.55 to 2.75 percentage points.

The purpose of the study described in this report was to determine the influence of variation in gradation on the relationships above.

A new lunar soil simulant, LSS No. 3, was prepared from the same stock used for LSS No. 2 but with a significantly coarser gradation. A relationship between astronaut footprint depth and porosity for the upper 15 cm was derived for LSS No. 3 using the same procedure used for LSS No. 2. Plane strain and confined compression tests were performed in the laboratory to obtain stress-strain parameters, a finite element program was used to model plate loading, large-scale laboratory

plate load tests were performed to check the validity of the parameters developed, and the finite element program was used to model the lunar gravity.

The response obtained was compared with the corresponding response for LSS No. 2. Differences may be attributed entirely to gradation effects because the simulants differed only in gradation. It was found that LSS No. 3 was less deformable than LSS No. 2 at low porosity, but the reverse was true at high porosity. At intermediate porosity, near 44%, no difference was observed.

It can, therefore, be inferred from these results that the average porosity computed from LSS No. 2 data alone is probably not significantly in error due to minor fluctuations in lunar soil gradation. On the other hand, the standard deviation computed from LSS No. 2 data may be somewhat erroneously high due to gradation differences. It is difficult to estimate how much of the standard deviation might be due to gradation fluctuations rather than porosity fluctuations, but it appears that it could be as high as one-third of the computed standard deviation.