



NATIONAL AERONAUTICS AND SPACE ADMINISTRATION
WASHINGTON, D.C. 20546

Ames

DEC 12 1974

REPLY TO
ATTN OF: GP

TO: KSI/Scientific & Technical Information Division
Attn: Miss Winnie M. Morgan

FROM: GP/Office of Assistant General
Counsel for Patent Matters

SUBJECT: Announcement of NASA-Owned U.S. Patents in STAR

In accordance with the procedures agreed upon by Code GP and Code KSI, the attached NASA-owned U.S. Patent is being forwarded for abstracting and announcement in NASA STAR.

The following information is provided:

U.S. Patent No. : 3,851,162

Government or Corporate Employee : U.S. Government

Supplementary Corporate Source (if applicable) : _____

NASA Patent Case No. : ARC-10,466-1

NOTE - If this patent covers an invention made by a corporate employee of a NASA Contractor, the following is applicable:

YES NO

Pursuant to Section 305(a) of the National Aeronautics and Space Act, the name of the Administrator of NASA appears on the first page of the patent; however, the name of the actual inventor (author) appears at the heading of column No. 1 of the Specification, following the words "...with respect to an invention of ..."

Bonnie L. Woerner
Bonnie L. Woerner
Enclosure

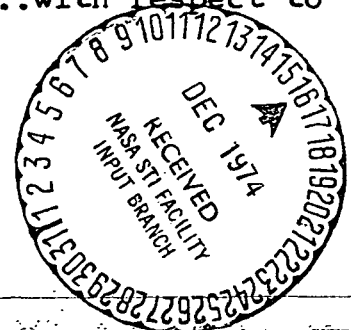

N/5-13539
Unclas 03977
00/60
(NASA-Case-ARC-10466-1) CONTINUOUS
FOURIER TRANSFORM METHOD AND APPARATUS
Patent (NASA) 12 p
CSCI 09B

[54] CONTINUOUS FOURIER TRANSFORM METHOD AND APPARATUS

[75] Inventor: Robert M. Munoz, Los Altos, Calif.

[73] Assignee: The United States of America as represented by the Administration of the National Aeronautics and Space Administration, Washington, D.C.

[22] Filed: Apr. 18, 1973

[21] Appl. No.: 352,382

[52] U.S. Cl. 235/156, 235/197, 324/77 B

[51] Int. Cl. G06f 15/34

[58] Field of Search 235/156, 152, 184, 181, 235/197

[56] References Cited UNITED STATES PATENTS

3,344,349	9/1967	Schroeder.....	324/77
3,529,142	9/1970	Robertson.....	235/197 X
3,610,901	10/1971	Lynch.....	235/156 X
3,636,333	1/1972	Klund.....	235/156
3,714,566	1/1973	Kang.....	235/156 X
T910,009	5/1973	Abramson.....	235/156 X

Primary Examiner—Felix D. Gruber
Assistant Examiner—James F. Gottman
Attorney, Agent, or Firm—Armand G. Morin; Darrell G. Brekke; John R. Manning

[57] ABSTRACT

An input analog signal to be frequency analyzed is separated into N number of simultaneous analog signal components each identical to the original but delayed relative to the original by a successively larger time delay. The separated and delayed analog components are combined together in a suitable number of adders and attenuators in accordance with at least one component product of the continuous Fourier transform and analog signal matrices to separate the analog input signal into at least one of its continuous analog frequency components of bandwidth $1/N$ times the bandwidth of the original input signal. Given the separated frequency components, the original analog input signal can be reconstituted by combining the separate analog frequency components in accordance with the component products of the continuous Fourier transform and analog frequency component matrices. The continuous Fourier transformation is useful for spectrum analysis, filtering, transfer function synthesis, and communications.

22 Claims, 10 Drawing Figures

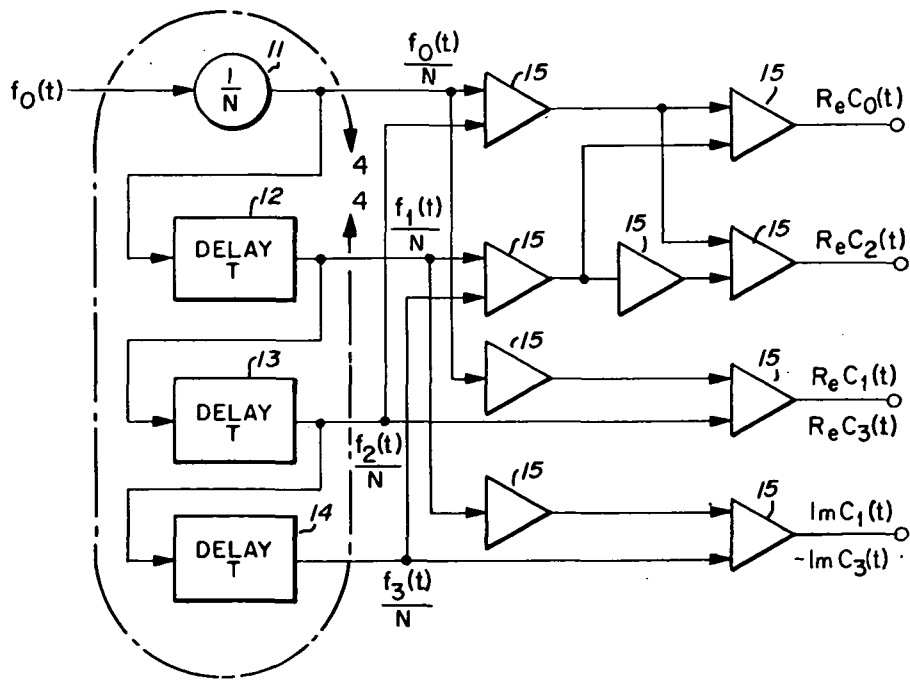

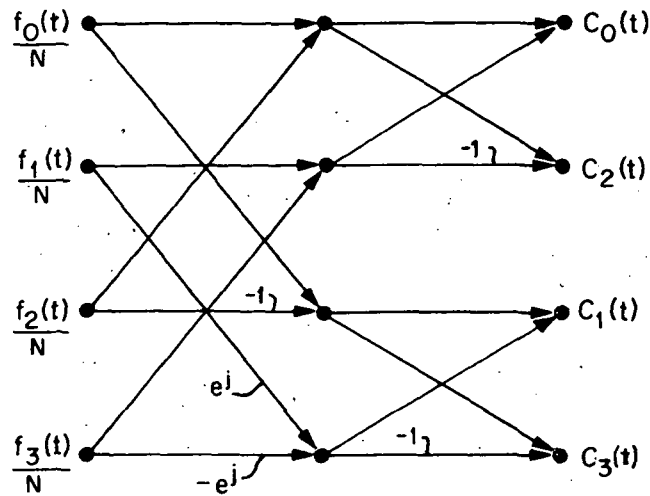

Fig-1

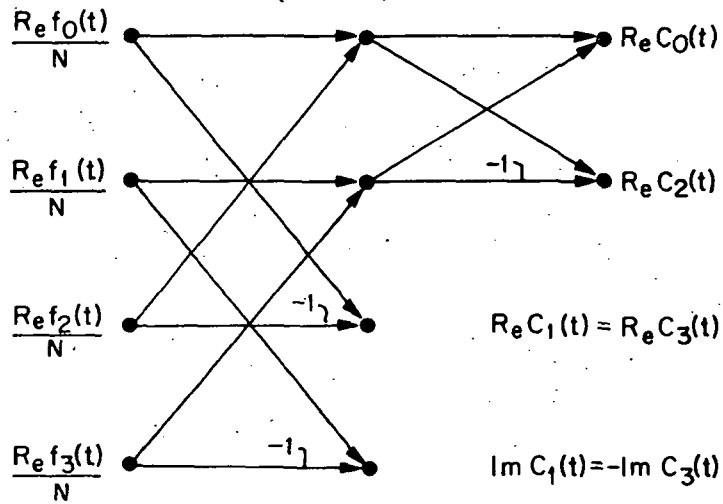

Fig-2

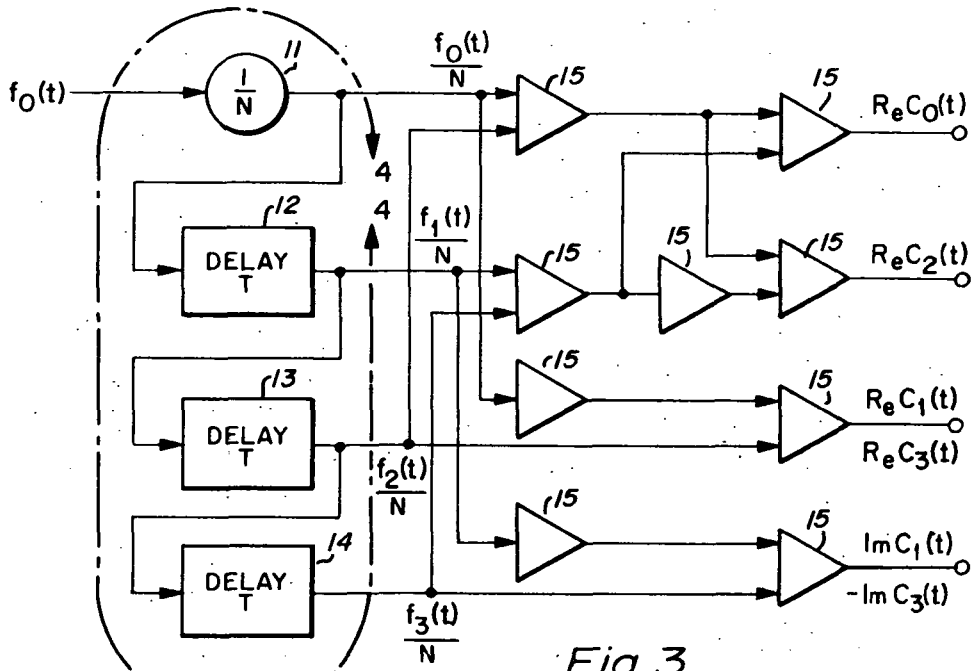

Fig. 3

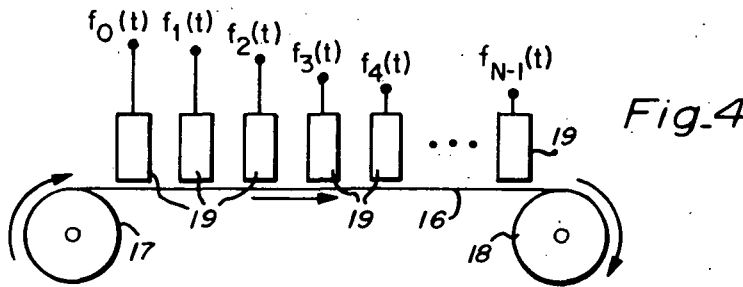

Fig. 4

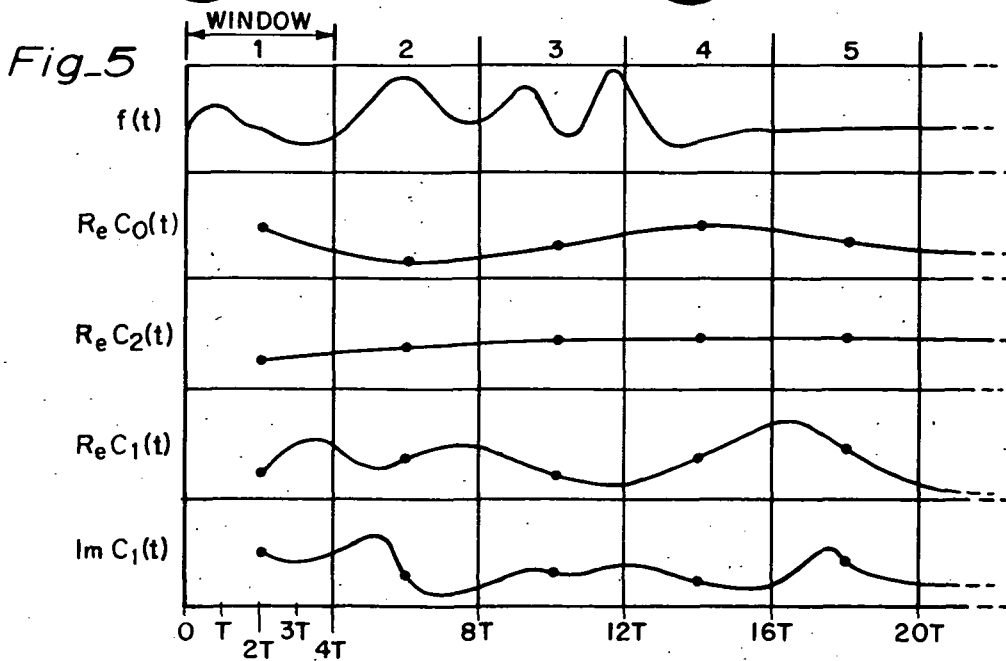
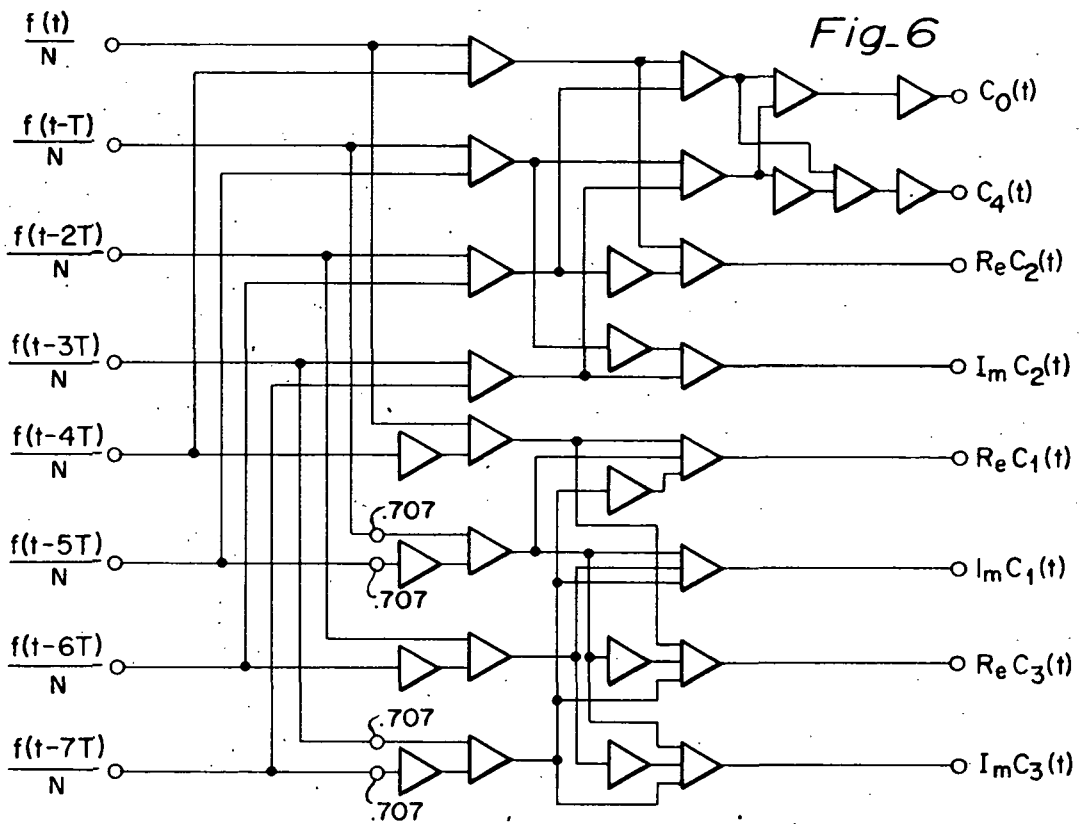
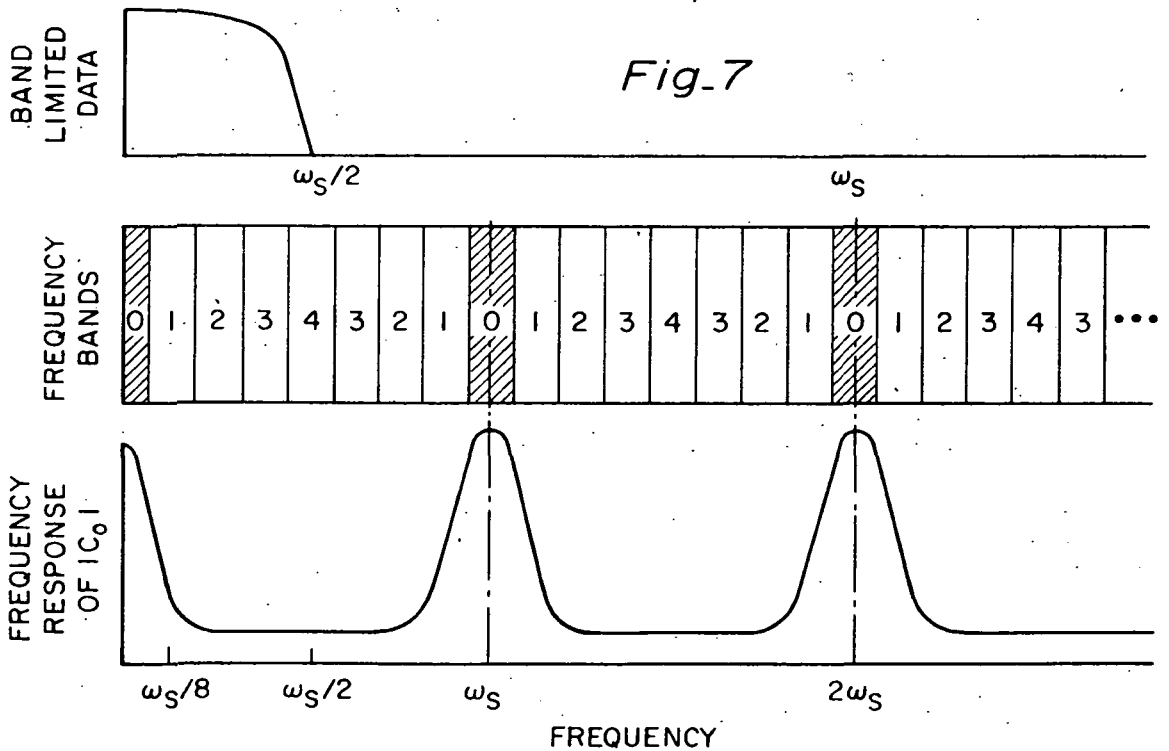

Fig. 5



ANALOG IMPLEMENTATION OF THE CONTINUOUS TRANSFORM FOR REAL SAMPLED TIME SERIES



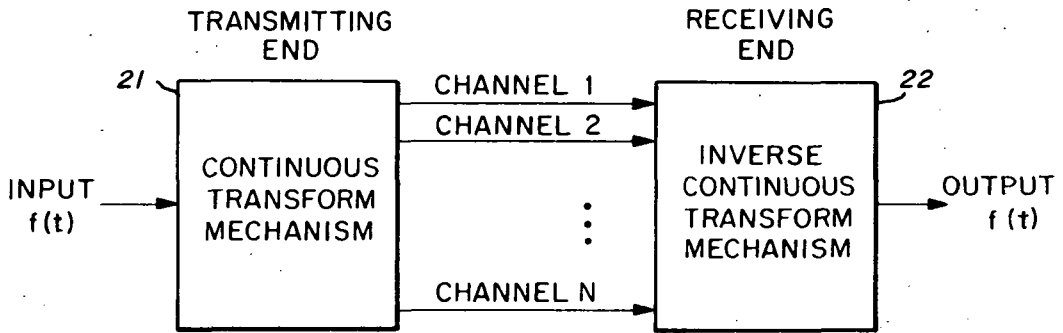

Fig. 8

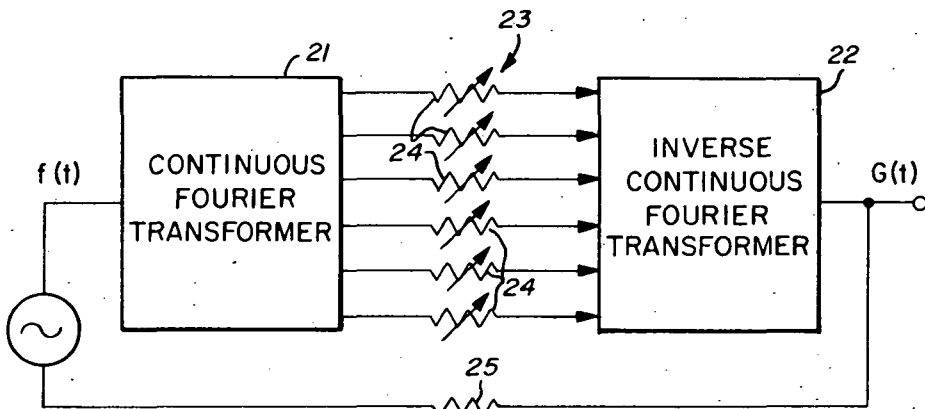

Fig. 9

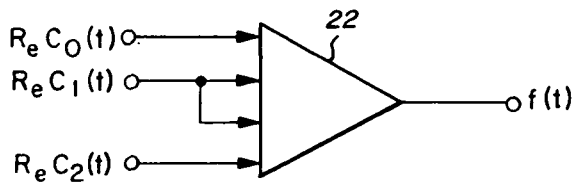

Fig. 10

CONTINUOUS FOURIER TRANSFORM METHOD AND APPARATUS

The invention described herein was made by an employee of the United States Government and may be manufactured and used by or for the Government for governmental purposes without the payment of any royalties thereon or therefor.

BACKGROUND OF THE INVENTION

The present invention relates in general to method and apparatus for performing Fourier transformations and more particularly to an improved continuous Fourier transformation and systems using same.

DESCRIPTION OF THE PRIOR ART

Heretofore, analog input signals have been analyzed by sampling the analog input signal at a multiplicity of time displaced intervals, converting such sampled data to discrete digital form in an analog to digital converter and performing a discrete Fourier transformation, typically by the fast Fourier transform method, to convert the signal data in the time domain into its corresponding discrete frequency components in the frequency domain, thereby obtaining a discrete spectral representation of the input signal to be analyzed.

It is also known from the prior art that once an analog signal has been separated into its corresponding discrete Fourier components in the frequency domain that a discrete representation of the original analog signal can be reconstituted by performing an inverse Fourier transformation on the discrete spectral Fourier components in a digital computer to derive a discrete representation of the original analog signal in the time domain. The discrete fast Fourier transform method and apparatus is disclosed in an article "What is the Fast Fourier Transform?" appearing in the I.E.E.E. Transactions on Audio and Electroacoustics, volume AU-15, No. 2, of June 1967, pages 45-55.

One of the problems with the discrete Fourier transform is that it requires the use of a digital computer with associated analog-to-digital converters and the analysis performed by the computer comprises many complex multiplications, additions, and memory cycles.

SUMMARY OF THE PRESENT INVENTION

The principal object of the present invention is the provision of an improved Fourier transform method and apparatus and more particularly of a simplified continuous Fourier transform method which does not require a complex digital computer for implementation.

In one feature of the present invention, an analog signal to be analyzed is separated into N number of analog components each delayed relative to the original signal or the reference one of said signal components by a successively larger time delay, such reference and delayed components are added together in accordance with at least one of the component products of the fast Fourier matrix (D matrix) and the delayed input signal component matrix $F(t)$ to produce at least one continuous output function $C_m(t)$ corresponding to one of the frequency components of the analog input signal to be analyzed.

In another feature of the present invention, the Fourier components in the frequency domain of an original

analog signal are combined in accordance with the component product of the discrete Fourier transform matrix (D matrix) and the Fourier components matrix ($C_m(t)$ matrix) to reconstitute the original analog input signal.

In another feature of the present invention, an analog input signal having a certain bandwidth is Fourier transformed into N number of Fourier frequency components each component having $1/N \times$ the bandwidth of the original input signal. Such separate Fourier frequency components are transmitted simultaneously over N number of different channels to a receiver. The received Fourier components are recombined in accordance with the inverse Fourier transform to reconstitute the original input signal, whereby a relatively wide bandwidth signal is transmitted over N number of relatively narrow band individual channels.

Other features and advantages of the present invention will become apparent upon a perusal of the following specification taken in connection with the accompanying drawings wherein:

BRIEF DESCRIPTION OF THE DRAWINGS

FIG. 1 is a signal flow graph depicting the continuous Fourier transformation of a complex (two-wire) analog input signal into four separate complex Fourier frequency components,

FIG. 2 is a signal flow graph depicting the continuous Fourier transformation of a real (one-wire) input signal to its respective Fourier frequency components,

FIG. 3 is a physical implementation of the system of FIG. 2,

FIG. 4 is an alternative physical implementation of the input portion of the circuit of FIG. 3 and delineated by line 4-4,

FIG. 5 is a plot of the input signal to be Fourier analyzed and the output Fourier components as a function of time and depicting the discrete Fourier transform output indicated by the dots superimposed upon the continuous Fourier transform output,

FIG. 6 is a schematic circuit diagram for a physical implementation of a continuous Fourier transform circuit similar to that of FIG. 3 except for eight time delayed input components,

FIG. 7 is a composite plot of band limited input signal data, frequency bands of the separate Fourier components, and the frequency response of the first Fourier frequency output coefficient C_0 , all as a function of frequency,

FIG. 8 is a schematic block diagram of a data transmission system incorporating features of the present invention,

FIG. 9 is a diagram similar to that of FIG. 8 for modifying an input signal, and

FIG. 10 is a schematic circuit diagram of an inverse continuous Fourier transform apparatus.

DESCRIPTION OF THE PREFERRED EMBODIMENTS

The prior method of discrete Fourier transform will first be described followed by a description of an extension thereof under the present invention to a continuous Fourier transform method and apparatus. In the discrete Fourier transform method, a band limited continuous complex function of time $f(t)$ is considered to contain a maximum frequency component $\omega_d/2$ wherein ω_d is the rate at which the function $f(t)$ is to be

sampled to produce a sampled data function $f^*(nT)$, where $T = 1/\omega_s$ seconds. A set of N sequentially ordered magnitudes of $f^*(nT)$ where $n = 0, 1, \dots, N-1$, is selected and the discrete Fourier transform of this set is as follows:

$$DFT(f(t)) = c_m = \frac{1}{N} \sum_{n=0}^{N-1} e^{\frac{2\pi jmn}{N}} f^*(nT) \tag{Eq. (1)}$$

where

$$j = \sqrt{-1}$$

$$m = 0, 1, \dots, N-1$$

and c_m are the N complex frequencies coefficients.

The inverse operation of computing the original data set from the coefficients is given as follows:

$$f^*(nT) = \sum_{m=0}^{N-1} e^{\frac{2\pi jmn}{N}} c_m \tag{Eq. (2)}$$

$$\begin{bmatrix} C_0(t) \\ C_1(t) \\ C_2(t) \\ \vdots \\ C_{N-1}(t) \end{bmatrix} = 1/N$$

20

Matrix Equation (5) may be expanded and written as follows:

$$\begin{bmatrix} 1 & 1 & \dots & 1 \\ 1 & e^{j} & \dots & e^{j(N-1)} \\ 1 & e^{2j} & \dots & e^{2j(N-1)} \\ \vdots & \vdots & \ddots & \vdots \\ 1 & e^{(N-1)j} & \dots & e^{(N-1)j(N-1)} \end{bmatrix} \begin{bmatrix} f_0(t) \\ f_1(t) \\ f_2(t) \\ \vdots \\ f_{N-1}(t) \end{bmatrix} \tag{Eq. (6)}$$

where $n = 0, 1, \dots, N-1$

These equations can be written in matrix form in the following way:

$$C = 1/N D F \tag{Eq. (3)}$$

and

$$F = D C \tag{Eq. (4)}$$

30 where

$$f(t) \triangleq f(t - jT)$$

As in the fast Fourier transform a considerable simplification in the computation is achieved if N is selected to be a binary number, i.e., a power of 2 such as 2, 4, 8, 16, etc. This simplifies F and greatly reduces the complexity. The matrix Equation (6), when solved for the complex frequency coefficients $C_m(t)$, produces a set of equations as follows:

$$C_0(t) = 1/N [f_0(t) + f_1(t) + f_2(t) + \dots + f_{N-1}(t)] \tag{7}$$

$$C_1(t) = 1/N [f_0(t) + e^{j} f_1(t) - f_2(t) - e^{j(N-1)} f_{N-1}(t)] \tag{8}$$

$$C_2(t) = 1/N [f_0(t) - f_1(t) + f_2(t) + \dots + e^{2j(N-1)} f_{N-1}(t)] \tag{9}$$

$$C_{N-1}(t) = 1/N [f_0(t) + e^{(N-1)j} f_1(t) - e^{2j(N-1)} f_2(t) + \dots + e^{(N-1)j(N-1)} f_{N-1}(t)] \tag{10}$$

where $C =$

$$\begin{bmatrix} C_0 \\ C_1 \\ \vdots \\ C_{N-1} \end{bmatrix}$$

and $F =$

$$\begin{bmatrix} f_0 \\ f_1 \\ \vdots \\ f_{N-1} \end{bmatrix}$$

$D =$

$$\begin{bmatrix} 1 & 1 & \dots & 1 \\ 1 & e^{j} & \dots & e^{j(N-1)} \\ 1 & e^{2j} & \dots & e^{2j(N-1)} \\ \vdots & \vdots & \ddots & \vdots \\ 1 & e^{(N-1)j} & \dots & e^{(N-1)j(N-1)} \end{bmatrix}$$

50

For $N = 4$, these equations reduced to:

$$C_0(t) = 1/N [f_0(t) + f_1(t) + f_2(t) + f_3(t)] \tag{Eq. (11)}$$

$$C_1(t) = 1/N [f_0(t) + e^{j} f_1(t) - f_2(t) - e^{j} f_3(t)] \tag{Eq. (12)}$$

$$C_2(t) = 1/N [f_0(t) - f_1(t) + f_2(t) - f_3(t)] \tag{Eq. (13)}$$

$$C_3(t) = 1/N [f_0(t) - e^{j} f_1(t) - f_2(t) + e^{j} f_3(t)] \tag{Eq. (14)}$$

The discrete fast Fourier transform is obtained for Equations (3) and (4) by recognizing and using the properties of the D matrix to simplify the computations. Since all entries in the D matrix are periodic roots of unity, and symmetric about the main diagonal, a great simplification is possible where N is a power of 2. The highest degree of symmetry and hence the greatest simplification is permitted when N fulfills this requirement. The matrix equations of (3) and (4) are typically solved with a digital computer programmed to perform the fast Fourier transform. The program involves many complex multiplications and additions. Although the computations are relatively complex the

55

60

65

The signal flow graph for Equations 11-14 is illustrated in FIG. 1. In the signal flow graph, each node represents a variable, and the arrows terminating at that node originate at the nodes whose variables contribute to the value of the variable at that node. The contributions are additive, and the weight of each contribution, if other than unity, is indicated by the constant written close to the arrowhead of the transmission. Equations 11-14 are separated into real and imaginary components as follows:

$$ReC_0(t) = 1/N [Ref_0(t) + Ref_1(t) + Ref_2(t) + Ref_3(t)] \quad (15)$$

$$ImC_0(t) = 1/N [Imf_0(t) + Imf_1(t) + Imf_2(t) + Imf_3(t)] \quad (16)$$

$$ReC_1(t) = 1/N [Ref_0(t) - Imf_1(t) - Ref_2(t) + Imf_3(t)] \quad (17)$$

$$ImC_1(t) = 1/N [Imf_0(t) + Ref_1(t) - Imf_2(t) - Ref_3(t)] \quad (18)$$

$$ReC_2(t) = 1/N [Ref_0(t) - Ref_1(t) + Ref_2(t) - Ref_3(t)] \quad (19)$$

$$ImC_2(t) = 1/N [Imf_0(t) - Imf_1(t) + Imf_2(t) - Imf_3(t)] \quad (20)$$

$$ReC_3(t) = 1/N [Ref_0(t) + Imf_1(t) - Ref_2(t) - Imf_3(t)] \quad (21)$$

$$ImC_3(t) = 1/N [Imf_0(t) - Ref_1(t) - Imf_2(t) + Ref_3(t)] \quad (22)$$

Equations 15-22 could be implemented with hardware, however, considering a one dimensional input; signal having only a real and no imaginary component; Equations 15-22 are greatly simplified by recognizing, that:

$$Imf_0(t) = Imf_1(t) = Imf_2(t) = Imf_3(t) = 0$$

Thus:

$$ReC_0(t) = 1/N [Ref_0(t) + Ref_1(t) + Ref_2(t) + Ref_3(t)] \quad (23)$$

$$ImC_0(t) = 0$$

Eq. (24)

$$ReC_1(t) = ReC_3(t) = 1/N [Ref_0(t) - Ref_2(t)] \quad (25)$$

$$ImC_1(t) = -ImC_3(t) = 1/N [Ref_1(t) - Ref_3(t)] \quad (26)$$

$$ReC_2(t) = 1/N [Ref_0(t) - Ref_1(t) + Ref_2(t) - Ref_3(t)] \quad (27)$$

Eq. (27)

$$ImC_2(t) = 0$$

Eq. (28)

$$ReC_3(t) = 1/N [Ref_0(t) - Ref_2(t)] \quad (29)$$

$$ImC_3(t) = 1/N [-Ref_1(t) + Ref_3(t)] \quad (30)$$

Eq. (30)

Since $ImC_0(t)$ and $ImC_2(t) = 0$, no hardware implementation for Fourier frequency components is necessary or possible. Therefore, equations 23-30 reduced to only four independent equations, namely Equations 13, 25, 26 and 27, the signal flow graph for which is depicted in FIG. 2. In the continuous transform, $f_0(t)$ is identical to the reference input signal $f(t)$ and $f_1(t)$ is identified with $f_0(t+T)$, $f_2(t)$ is identified with $f_0(t+2T)$ and $f_3(t)$ is identified with $f_0(t+3T)$.

The signal flow graph of FIG. 2 is implemented with hardware as shown in FIG. 3 to provide a continuous Fourier transform apparatus. More particularly, the input function of time $f(t)$ (magnitude) is first divided by N in attenuator 11 to provide a first reference input signal $f_0(t)/N$. $1/N$ is a scaling constant equal to the reciprocal of the number of Fourier frequency components. A sample of the output of the attenuator 11 is fed to a first delay 12 to be delayed by a time T . The output of the delay 12 forms the second input signal, namely $f_1(t)/N$. A sample of the output of delay 12 is fed to a second delay 13 which delays the signal passing therethrough by the same time T such that the output

of the second delay 13 forms the third input signal, namely $f_2(t)/N$. An output of the second delay 13 is fed to a third delay 14 for delaying the fourth signal by a time T relative to the third signal to produce the fourth input reference signals namely $f_3(t)/N$. The continuous input signals are combined in the inverting operational amplifiers 15 in accordance with the signal flow graph of FIG. 2 to produce the four outputs, namely, $ReC_0(t)$, $ReC_2(t)$, $ReC_1(t) = ReC_3(t)$, $ImC_1(t) = -ImC_3(t)$.

One relatively simple apparatus for deriving the time delayed input signals for the input to the circuit of FIG. 3 is as shown in FIG. 4. More particularly, the input signal $f(t)$ to be Fourier analyzed is recorded on a magnetic recording tape 16. The magnetic recording tape 16 is drawn from a supply reel 17 onto a take-up reel 18 across a number of pick-up heads 19 each head 19 being equally spaced from the adjacent head in the direction of movement of the recording tape 16. The outputs from each of the downstream heads 19 is successively delayed by a successively larger time compared to the output of the upstream head or reference head. The respective output signals are indicated above each of the respective heads.

Referring now to FIG. 5, there is shown the signal to be analyzed $f(t)$ and its Fourier frequency components for $N=4$ and corresponding to the four outputs of the circuit of FIG. 3. In FIG. 5, $f(t)$ is shown being separated into $N=4$ components and sampled four times per time window where the time window No. 1 is defined as 0 to $4T$. The information contained in the four components $ReC_0(t)$, $ReC_2(t)$, $ReC_1(t)$ and $ImC_1(t)$ is no greater nor less than that contained in the four original samples because the continuous Fourier transform process is conservative, that is, it permits information neither to be created nor destroyed. Since only one unique set of Fourier frequency components per window is allowed to characterize $f(t)$, according to the sampling theorem, each Fourier frequency component must then contain only $1/N \times$ the bandwidth limit of $f(t)$ or a maximum frequency content of $\omega_s/2N = \omega_s/8$ Hz. This accounts for the bandwidth reduction in the discrete or sampled data case and this has a direct and immediate implication for the continuous transform mechanism.

The continuous transform method is related to the series of discrete Fourier transforms in successive time windows 1, 2, . . . p and at the limit of this process, i.e., when p goes to infinity and T goes to zero, the bandwidth relationships are invariant for both p and T . Therefore, they obtain in the limit and apply equally well for the continuous transform case, i.e., the bandwidth of any Fourier component $C_i(t) = 1/N$ bandlimit of $f(t)$.

The continuous Fourier transform mechanism of the present invention is suited to many practical applications including filtering, spectral analysis, and transfer function modification in the frequency or time domain. In short, it can do all that the theory permits of any Fourier transform mechanism and for some applications it results in very simple and inexpensive hardware.

Referring now to FIG. 6 there is shown a Fourier transform circuit similar to that of FIG. 3 where $N=8$. As can be seen in FIG. 6, the hardware implementation involves merely attenuators and amplifiers as contrasted with the prior art discrete Fourier transform mechanism that requires complex multiplication, addi-

tion and memory cycles. The frequency characteristics of the continuous transform mechanism for the circuit of FIG. 6 is shown in FIG. 7 where $N = 8$ and $Imf(t) = 0$. The information band of $f(t)$ from zero to $\omega_s/2$, is separated into five equibandwidth parts by the output frequency components C_0 through C_4 as indicated by frequency bands 0 through 4. This operation of producing Fourier frequency components on a continuous basis is identical to the operation of filtering with the added advantage that an exact measurement of the phase of the incoming signal with respect to ω_s is possible for each band. It can be seen that the C_0 component acts as a low pass filter and C_1 acts as a bandpass filter, etc., each band having a bandwidth of $(+)\omega_s/2N$ around their respective center frequencies of $m\omega_s/2N$ where $m = 0, 1, \dots, (N-1)$. All this filtering action takes place simultaneously and continuously and therefore constitutes a parallel set of $N/2$ filters or a spectrum analyzer. If only one filter is needed, then the hardware can be simplified greatly.

At frequencies above $\omega_s/2$ the action of filtering, unlike that of ordinary filters, repeats itself in a cyclical manner as indicated by the frequency band containing the same number designation in FIG. 7. This was the reason for band limiting the input signal $f(t)$ to avoid signal aliasing and the consequent confusion of data

similar to that of FIG. 8 with the exception that variable attenuators 24 are placed in each of the respective channels between the continuous Fourier transform mechanism 21 and the inverse continuous Fourier transform mechanism 22 for modifying the frequency components in the frequency domain. The reconstituted modified output signal $G(t)$ appears at the output across a load resistor 25. Convolutions in frequency or time can be performed by using two continuous transform systems of the type shown in FIG. 9 and multiplying the input signals or the frequency components respectively and reconstituting or transforming these products using another transform mechanism.

Once an input signal in the time domain has been separated into its continuous fast Fourier transform components $C_m(t)$ in the frequency domain these components can be recombined to form the original signal $f(t)$ by means of the inverse Fourier transform, the discrete version of which is shown in Eq. (4). In the continuous Fourier transform, Equation (4) is rewritten as:

$$F(t) = D C(t) \tag{31}$$

Equation (31) is solved for $f_0(t) = f(t)$ and for $N = 4$ as follows:

$$\begin{bmatrix} f_0(t) \\ f_1(t) \\ f_2(t) \\ f_3(t) \end{bmatrix} = \begin{bmatrix} f(t) \\ f(t-T) \\ f(t-2T) \\ f(t-3T) \end{bmatrix} = \begin{bmatrix} 1 & 1 & 1 & 1 \\ 1 & e^j & e^{2j} & e^{3j} \\ 1 & e^{2j} & e^{4j} & e^{6j} \\ 1 & e^{3j} & e^{6j} & e^{9j} \end{bmatrix} \begin{bmatrix} C_0(t) \\ C_1(t) \\ C_2(t) \\ C_3(t) \end{bmatrix} \tag{32}$$

that results. However, for some applications this action may be desirable for use in a periodic filter as, for example, in the magnetic amplifier or flux gate magnetometer where the output signals are contained in all even harmonics of the drive signal and it is necessary to reject the odd harmonics and extraneous noises in other bands.

Many types of periodic filters are possible such as even and odd harmonics as well as third, fifth, eleventh, thirteenth, nineteenth . . . harmonic types, each selected as combinations of frequency bands containing in the same band number or numbers. This action can, of course, be accomplished simultaneously for different combinations and may be useful for human speech and music signal analysis.

Returning now to band limited information input signals, the continuous transform mechanism can be used to make a communication system capable of sending high bandwidth information over a plurality of N low bandwidth lines or channels. Such a transmission system is shown in FIG. 8. In FIG. 8, the input signal $f(t)$ is continuously Fourier transformed in Fourier transformer 21 in a manner as previously described with regard to FIG. 3. The output of transform mechanism 21 is N frequency components with the attendant bandwidth reduction of $1/N$ for each of such Fourier frequency components. The components are then transmitted over separate channels 1 through N to be reconstituted at the receiving end via an inverse continuous transform mechanism 22 into a facsimile of the original signal.

Referring now to FIG. 9 there is shown an apparatus 23 adapted for transfer function modification in the frequency domain. More particularly, the system is

From Equation (32):
 $f(t) = C_0(t) + C_1(t) + C_2(t) + C_3(t)$ Eq. (33)

Taking into account real and imaginary components,
 $f(t) = ReC_0(t) + ImC_0(t) + ReC_1(t) + ImC_1(t) + ReC_2(t) + ImC_2(t) + ReC_3(t) + ImC_3(t)$ Eq. (34)

Assuming the imaginary part of $F(t) = 0$ then, $ImC_0(t) = ImC_2(t) = 0$ and $ReC_1(t) = ReC_3(t)$ and $ImC_1(t) = -ImC_3(t)$ then:
 $f(t) = ReC_0(t) + 2 ReC_1(t) + ReC_2(t)$ Eq. (35)

Equation (35) is implemented by the hardware of FIG. 10 and consists only of the positive sum of three components. The amplifier 22 is a non-inverting operational amplifier with four input terminals each of a + unity gain. The input signal $ReC_1(t)$ is connected into two input terminals to yield a gain of two. The output of the inverse continuous transformer 22 is the reconstituted original input signal $f(t)$.

The continuous Fourier transform mechanism of the present invention is useful for filtering, signal processing and communications. In filtering, it may be utilized for lowpass filtering, bandpass filtering, parallel filtering and chorus filtering (a selected set of harmonically related frequencies and combinations), specialized filtering of spectral signatures, and phase lock filtering or phase discrimination such as that used in space communication, and it is also useful for complex signal filtering.

The advantage of the continuous Fourier transform apparatus of the present invention as applied to filtering is that very accurate frequency selection is obtained there being no practical limit on the minimum bandwidth. The filtering circuits are inexpensive to imple-

ment in hardware as the hardware comprises merely amplifiers and in some cases attenuators.

In signal processing, such as in a system described with regard to FIG. 9, the continuous Fourier transform apparatus of the present invention is useful for transfer function modification in the frequency domain. It may also be utilized for spectrum analysis of continuous data (quasi stationary and non stationary time series produce deterministic results). It may also be utilized for serial-to-parallel data conversion and parallel-to-serial data conversion.

In communications, such as the system described with regard to FIG. 8, the continuous transform mechanism is useful for bandwidth reduction in the individual communication channels. It may also be useful for video tape recording utilizing multiple tape heads.

What is claimed is:

1. In a method for continuous analog analysis for a time varying input function $f(t)$ in the time domain into at least one of its Fourier Frequency components $C_m(t)$ the steps of:

continuously producing N signal components $f_m(t)/N$ ranging from $f_0(t)/N$ to $f_{N-1}(t)/N$ wherein each signal component except $f_0(t)/N$ is delayed an amount T from the previous signal component;

continuously combining separated ones of said signal components $[f_m(t)] f_m(t)/N$ together so as to produce at least one continuous output function $C_m(t)$ corresponding to one of the Fourier frequency components of the time varying input function $f(t)$ to be frequency analyzed.

2. The method of claim 1 wherein the step of combining said separated components $f_m(t)/N$ together so as to produce at least one output function $C_m(t)$ corresponding to one of the Fourier frequency components of the time varying input signal $f(t)$ comprises the step of, combining the time delayed continuous signal components $f_m(t)/N$ together according to at least one of the component products of the matrix product: $DF(t)$ where D is the discrete Fourier transform matrix and $F(t)$ is the delayed input signal component matrix.

3. The method of claim 2 wherein the step of combining the delayed signal components $f_m(t)/N$ according to at least one component product of the matrix product includes the step of, adding the delayed signal components $f_m(t)/N$ according to at least one of the component products of said matrix product.

4. The method of claim 2 wherein D is defined by the matrix:

$$D = \begin{bmatrix} 1 & 1 & \dots & 1 \\ 1 & e^{j2\pi} & \dots & e^{j2\pi(N-1)} \\ 1 & e^{j4\pi} & \dots & e^{j4\pi(N-1)} \\ \dots & \dots & \dots & \dots \\ \dots & \dots & \dots & \dots \\ 1 & e^{j2\pi(N-1)} & \dots & e^{j2\pi(N-1)^2} \end{bmatrix}$$

5. The method of claim 1 wherein N is a power of 2.

6. The method for reconstituting a time varying function $f(t)$ in the time domain from a plurality of N number of its continuously time varying $C_m(t)$ Fourier frequency components in the frequency domain the steps of:

continuously combining the separate Fourier frequency components $C_m(t)$ according to the product of the matrix equation

$$f(t) = DC(t)$$

where D is the discrete Fourier transform matrix and $C(t)$ is the matrix for the continuous separate Fourier frequency components.

7. The method of claim 6 wherein the step of combining a plurality of the continuous time varying Fourier frequency components $C_m(t)$ together so as to reconstitute the original time varying function $f(t)$ includes, combining the separate Fourier frequency components $C_m(t)$ according to the product of the matrix Equation:

$$f(t) = DC(t)$$

where D is the discrete Fourier transform matrix and $C(t)$ is the matrix for the continuous separate Fourier frequency components.

8. The method of claim 7 wherein the D matrix is defined by the matrix equation:

$$D = \begin{bmatrix} 1 & 1 & \dots & 1 \\ 1 & e^{j2\pi} & \dots & e^{j2\pi(N-1)} \\ 1 & e^{j4\pi} & \dots & e^{j4\pi(N-1)} \\ \dots & \dots & \dots & \dots \\ \dots & \dots & \dots & \dots \\ 1 & e^{j2\pi(N-1)} & \dots & e^{j2\pi(N-1)^2} \end{bmatrix}$$

9. The method of claim 8 where

$$C(t) = \begin{bmatrix} C_0(t) \\ C_1(t) \\ \dots \\ C_{N-1}(t) \end{bmatrix}$$

10. In an analog apparatus for continuous frequency analysis of a time varying input function $f(t)$ in the time domain into at least one of its Fourier frequency components $C_m(t)$:

means for continuously generating N signal components

$f_m(t)/N$ ranging from $f_0(t)/N$ to $f_{N-1}(t)/N$ wherein each signal component except $f_0(t)/N$ is delayed an amount T from the previous signal component;

means for continuously combining said signal components $f_m(t)/N$ together so as to produce at least one continuous output function $C_m(t)$ corresponding to one of the Fourier frequency components of the time varying input function $f(t)$ to be frequency analyzed.

11. The analog apparatus of claim 10 wherein the means for combining said separated signal components $f_m(t)/N$ together so as to produce at least one output function $C_m(t)$ corresponding to one of the Fourier frequency components of the time varying input signal $f(t)$ includes, means for combining the time delayed continuous signal components $f_m(t)/N$ according to at least one of the component products of the matrix product:

$$DF(t)$$

where D is the discrete Fourier transform matrix and $F(t)$ is the separated input signal component matrix.

12. The analog apparatus of claim 11 wherein said means for combining the delayed signal components according to at least one component product of the matrix product includes, means for adding the delayed signal components according to at least one of the component products of said matrix product.

13. The analog apparatus of claim 11 where D is defined by the matrix:

$$D = \begin{bmatrix} 1 & 1 & \dots & 1 \\ 1 & e^{2j} & \dots & e^{2(N-1)j} \\ 1 & e^{4j} & \dots & e^{2(N-1)2j} \\ \dots & \dots & \dots & \dots \\ 1 & e^{2(N-1)j} & \dots & e^{2(N-1)2j} \end{bmatrix}$$

14. The analog apparatus of claim 10 wherein N is a power of 2.

15. Apparatus comprising:

first analog means for continuously producing N time varying Fourier frequency components $C_m(t)$ in the frequency domain of a time varying function $f(t)$ in the time domain;

said first analog means comprising: means for continuously generating N signal components $f_m(t)/N$ ranging from $f_0(t)/N$ to $f_{N-1}(t)/N$ wherein each signal component except $f_0(t)/N$ is delayed an amount T from the previous signal component; and means for continuously combining said signal components $f_m(t)/N$ together so as to produce N varying Fourier frequency components $C_m(t)$;

channel means for conveying each time varying Fourier frequency component to an inverse Fourier transformer, said transformer comprising second analog means for combining the continuously time varying Fourier components $C_m(t)$ together so as to reconstitute the original time varying function $f(t)$.

16. The apparatus of claim 15 wherein said means for combining a plurality of the continuously time varying frequency components $C_m(t)$ together so as to reconstitute the original time varying function $f(t)$ includes, means for combining the separate frequency components $C_m(t)$ according to the component products of the matrix product

$$DC(t)$$

where D is the discrete Fourier transform matrix and $C(t)$ is the matrix for the continuous separate Fourier frequency components.

17. The apparatus of claim 16 wherein:

$$D = \begin{bmatrix} 1 & 1 & \dots & 1 \\ 1 & e^{2j} & \dots & e^{2(N-1)j} \\ 1 & e^{4j} & \dots & e^{2(N-1)2j} \\ \dots & \dots & \dots & \dots \\ 1 & e^{2(N-1)j} & \dots & e^{2(N-1)2j} \end{bmatrix}$$

18. The apparatus of claim 17 wherein:

$$C(t) = \begin{bmatrix} C_0(t) \\ C_1(t) \\ \vdots \\ C_{N-1}(t) \end{bmatrix}$$

19. In an analog apparatus for continuous frequency analysis of a time varying input function $f(t)$ in the time domain into at least one of its Fourier frequency components $C_m(t)$:

5 means for continuously generating N signal components $f_m(t)/N$ ranging from $f_0(t)/N$ to $f_{N-1}(t)/N$ wherein each signal component except $f_0(t)/N$ is delayed an amount T from the previous signal component;

10 said generating means including a tape recorder with a recording head and $(N-2)$ staggered playback heads, said signal component $f_0(t)/N$ being connected to said recording head and each of the remaining signal components being produced at one of said playback heads;

15 means for continuously combining said signal components $f_m(t)/N$ together so as to produce at least one continuous output function $C_m(t)$ corresponding to one of the Fourier frequency components of the time varying input function $f(t)$ to be frequency analyzed.

20 An analog apparatus as set forth in claim 19 wherein said means for continuously combining signal components consists of a network of operational ampli-

25 fiers.

21. Apparatus comprising: first analog means for continuously producing N time varying Fourier frequency components $C_m(t)$ in the frequency domain of a time varying function $f(t)$ in the time domain;

said first analog means comprising: means for continuously generating N signal components $f_m(t)/N$ ranging from $f_0(t)/N$ to $f_{N-1}(t)/N$ wherein each signal except $f_0(t)/N$ is delayed an amount T from the previous signal component; and means for continuously combining said signal components $f_m(t)/N$ together so as to produce N varying Fourier frequency components $C_m(t)$;

40 said generating means including a tape recorder with a recording head and $(N-2)$ staggered playback heads, said signal component $f_0(t)/N$ being connected to said recording head and each of the remaining signal components being produced at one of said playback heads;

45 channel means for conveying each time varying Fourier frequency component to an inverse Fourier transformer, said transformer comprising second analog means for combining the continuously time varying Fourier components $C_m(t)$ together so as to reconstitute the original time varying function $f(t)$;

said combining means consisting of a network of operational amplifiers.

22. Apparatus as set forth in claim 21 wherein said inverse Fourier transformer consists of a network of operational amplifiers and attenuators.

* * * * *