

NATIONAL AERONAUTICS AND SPACE ADMINISTRATION

Technical Memorandum 33-692

*Implementation of the 64-Meter-Diameter Antennas
at the Deep Space Stations in
Australia and Spain*

K. P. Bartos

H. B. Bell

H. P. Phillips

B. M. Sweetser

O. A. Rotach

(NASA-CR-142091) IMPLEMENTATION OF THE 64-METER-DIAMETER ANTENNAS AT THE DEEP SPACE STATIONS IN AUSTRALIA AND SPAIN (Jet Propulsion Lab.) 67 p HC \$4.25 CSCL 09E N75-16737
G3/33 09628 Unclas



JET PROPULSION LABORATORY
CALIFORNIA INSTITUTE OF TECHNOLOGY
PASADENA, CALIFORNIA

January 15, 1975

Prepared Under Contract No. NAS 7-100
National Aeronautics and Space Administration

PREFACE

The series of studies undertaken at JPL in 1960 to investigate the feasibility of an antenna 61 to 76 m (200 to 250 ft) in diameter revealed that a 64-m (210-ft) antenna was within the state of the art and cost effective. The construction, testing, and operation of the first 64-m antenna at Deep Space Station 14 (DSS 14) in the Goldstone Deep Space Communications Complex amply confirm that judgment. This antenna has proved to be of tremendous value, and a continual demand has been made for its services. Since DSS 14 started operation, every deep space mission has used its support. Radar science of several types, with and without spacecraft, was carried out with most gratifying results, and high praise has been extended to the scientists for the antenna performance.

All of these factors provided the assurance that the next step should be undertaken - the completion of a world-wide network of 64-m antenna stations. NASA's policy of maintaining constant contact with spacecraft had from the beginning necessitated the supplementing of the 26-m stations in Australia and Spain with the enhanced capability of a 64-m antenna. Congress approved the funding for the construction, to be begun in 1969. Making cost-effective use of existing facilities, construction of the 64-m-diam antennas was completed in Canberra, Australia and Madrid, Spain. Constant spacecraft coverage is now possible.

CONTENTS

	<u>Page</u>
I. Introduction	1
II. Program Management	2
A. Funding	2
B. Project Management and Control	2
III. Utilization of Resources	4
A. Funds	4
B. Manpower	4
C. Major Industrial Participants	4
IV. Description of the Antenna System	6
A. General Description	6
B. Pedestal, Instrument Tower, and Cable Wrapup	6
C. Antenna Mount	7
D. Tipping Structure	8
E. Servo and Angle Data System	8
F. Supporting Facilities	9
V. Fabrication Phase	11
A. Hydrostatic Bearing Runner and Reservoir Assembly	11
B. Radial Bearing	11
C. Alidade	12
D. Azimuth and Elevation Gear Drives	12
E. Servo and Hydrostatic Bearing Hydraulic	12
F. Tipping Structure	12
G. Reflector Panels	12
H. Elevation Bearings	12
I. Instrument Tower	12
J. Summary	12
VI. Quality Assurance	14
A. General	14
B. Organization	14
C. Evaluation of the Quality Assurance Program	14
VII. History of Field Construction - Australia	16
A. Introduction	16
B. Contractor Site Organization	16
C. Site Conditions and Physical Plant	17
D. Construction	18

E.	Schedule	20
F.	Manpower	21
G.	Materials	21
H.	Safety	21
I.	JPL Site Organization and Responsibilities	21
VIII.	Site Construction History – Spain	23
A.	Introduction	23
B.	Contractor Site Organization	23
C.	Interfaces	24
D.	Site Conditions and Contractor Physical Plant	24
E.	Construction, Construction Techniques, and Problems	26
F.	Schedule	29
G.	Manpower and Local Labor	30
H.	European Materials and Services	30
I.	Safety	30
J.	JPL Site Organization and Responsibilities	31
IX.	Tricone Fabrication and Installation	32
A.	Introduction	32
B.	DSS 43 Installation	32
C.	DSS 63 Installation	32

FIGURES

1.	Continuous coverage of planetary spacecraft provided by the three-station subnet of 64-m antennas operating down to 6-deg elevation (receive mode and 20-kW transmit mode)	34
2.	Continuous coverage of planetary spacecraft provided by the three-station subnet of 64-m antennas operating down to 10-deg elevation (post-1975 era high power transmit mode)	35
3.	Overall Organization	36
4.	Work breakdown structure	36
5.	Project technical organization (functional flow)	37
6.	Project reporting flow	38
7.	Master milestone schedule – Australia, start of project	39
8.	Master milestone schedule – Spain, start of project	40
9.	Master milestone schedule – Australia, actual completion dates	41
10.	Master milestone schedule – Spain, actual completion dates	42
11.	Antenna major components	43

12.	Pedestal, cable wrapup, and instrument tower	44
13.	Antenna mount	45
14.	Servo hydraulics assembly	46
15.	Tipping assembly	47
16.	Multiple primary feed system	48
17.	Angle data assembly antenna mounted components	49
18.	Fire alarm and water distribution network	50
19.	26-m/64-m antenna location in Australia	51
20.	Construction schedule - Australia	52
21.	Contractor (manpower loading - Australia)	53
22.	Site location - Spain	54
23.	Construction schedule - Spain	55
24.	64-m antenna construction manpower loading - Spain	57

ABSTRACT

This report describes the management and construction aspects of the Overseas 64-m Antenna Project in which two 64-m antennas were constructed — one at the Tidbinbilla Deep Space Communications Complex in Australia, and another at the Madrid Deep Space Communications Complex in Spain. With the completion of these antennas the National Aeronautics and Space Administration/Jet Propulsion Laboratory Deep Space Network is equipped with three 64-m antennas spaced around the world to maintain continuous coverage of spacecraft operations. These antennas provide approximately a 7-dB gain over the capabilities of the existing 26-m antenna nets.

The two large complex antenna structures with their supporting facilities were fabricated in the United States. Under the direction of the Jet Propulsion Laboratory, an American prime contractor, with numerous domestic and foreign subcontractors, constructed the antenna instrument. Other American contractors, under the Jet Propulsion Laboratory, provided certain major components. Foreign contractors, operating under local agencies, constructed the supporting facilities.

The report outlines the project organization and management, resource utilization, fabrication, Quality Assurance, and construction methods by which the project was successfully completed. Major problems and their solutions are described as well as recommendations for future projects.

I. INTRODUCTION

The project described in this report includes construction of two deep space advanced antenna (64-m-diam) facilities, one in Spain and one in Australia, with the provision of sufficient electronic equipment to meet minimum performance requirements of the NASA deep space missions through 1975. These antennas are part of the National Aeronautics and Space Administration (NASA)/Jet Propulsion Laboratory (JPL) Deep Space Network (DSN). These two facilities, coupled with the first one constructed at the Goldstone Deep Space Communications Complex (DSCC), provide a complete three-station subnet, appropriately spaced around the earth, giving continuous coverage of spacecraft on planetary exploration missions.

These new higher gain antennas permit increasing the data flow from spacecraft to ground, provide positive command control, extend the useful life of planetary spacecraft, and provide simultaneous facility operations from the same longitude with either or both the 26-m and 64-m-diam antennas. The selection of Spain, Australia, and California for the three-station subnet was based on a review of all world areas, with respect to logistics, proper locations to fulfill deep space communications objectives, and best utilization of the operational coverage capability of the 64-m-diam antennas. General criteria for selection were: proper location; suitable natural environment (one that would not be subject to danger to natural resources); low radio-frequency noise environment; and suitable support capability. Facility construction was minimized by locating the 64-m-diam antennas within the areas of existing network stations with 26-m-diam antennas.

Results of studies showed that the locations selected would provide 99.9% coverage between 28.5°N latitude and 28.5°S latitude, which is the zone of interest. Figure 1 shows the coverage provided by the three-station subnet with the antennas operating as low as a 6-deg elevation in the receive mode and 20-kW transmit mode.

Figure 2 shows the coverage provided by the three-station subnet operating down to a 10-deg elevation for the higher power transmit mode.

The antenna construction project was undertaken by JPL under Contract 7-270(F), Task Agreements 2 and 3, between the California Institute of Technology and NASA. The cognizant office at NASA was the Office of Tracking and Data Acquisition (OTDA). The construction of the antenna instrument was contracted to Collins Radio Corp. after a NASA/JPL standard Source Evaluation Board procedure. Supporting facilities for the antenna in Spain were handled by the U. S. Navy Officer in charge of construction in Madrid, and for the antenna in Australia by the Australian Departments of Supply and Works. The tricone installation on the antennas and other electronic facilities were procured by JPL directly. The entire project was handled through a project office set up in the JPL DSN Engineering Section of the Telecommunications Division, with program direction by the OTDA. This organizational arrangement, together with well-established reporting procedures, provided the control necessary for the success of the project.

This report describes the project organization and management control methods, reviews the design changes included due to experience with the first antenna at the Goldstone DSCC, provides a historical summary of the fabrication and field construction at both sites, and compares the performance characteristics of the antenna system to specifications.

The addition of higher power transmitter equipment is planned for future increased capability. In support of this planned equipment, and to minimize future antenna downtime, certain additions to the antenna instruments and site facilities and some antenna-mounted electronic equipment will be implemented with completion in mid 1975. An addendum to this report will be issued covering this additional effort following its completion.

II. PROGRAM MANAGEMENT

A. FUNDING

The funding for the project was divided among four categories: Facility Planning and Design, Construction of Facilities, Electronics Equipment (not part of this report) and Manpower. The overall Project Funding Plan through FY 1974 was as follows:

<u>Category</u>	<u>Cost,</u> <u>thousands of dollars</u>	
Facility planning and design	522	
Antenna mechanical	25,031	} 34,000
Site support facility	5,124	
Antenna-mounted electronics	3,845	
Electronic equipment (R&D total)	4,016	
Manpower (R&D) total	5,192	

B. PROJECT MANAGEMENT AND CONTROL

1. Overall Program Management

Overall program management was under the cognizance of the NASA Office of Tracking and Data Acquisition. Robert A. Rapp was appointed the Program Manager. Responsibility for the project management was assigned to JPL.

Within JPL, the Assistant Laboratory Director for Tracking and Data Acquisition, William H. Bayley, was assigned the task of ensuring the project implementation and performance commitment to NASA. Mr. Bayley was assisted by his deputy, Walter K. Victor.

Implementation of the project was accomplished primarily within the Tracking and Data Acquisition organization under the direction of the Telecommunications Division Manager. The principal cognizant JPL element under the Division

was the DSN Engineering Section. Liaison with the Network Operations personnel (ultimate user of the antenna) was maintained throughout the project.

The project team responsible for the accomplishment of the 64-m subnet completion was made up primarily of members of the DSN Engineering Section, assisted by other elements of JPL, including quality assurance, finance and procurement, transportation, safety, and security.

The project team was qualified in the field of large antenna design, erection, and operation because of its experience in the construction of existing facilities in the JPL/NASA Deep Space Network in the United States, as well as overseas locations. The Project Manager, W.D. Merrick, was the Project Manager for the 64-m-diam antenna constructed at the Goldstone DSCC in California.

Figure 3 shows the overall JPL organization directly related to the project. Although not included on this organization chart, the services of normal administrative, and technical elements of JPL supported the project team as required.

2. Project Organization

(1) The Telecommunications Division Manager was responsible for the overall technical coordination and direction of the project utilizing resources of the equipment development sections and the operation sections under his cognizance.

(2) The Project Manager was responsible for the proper implementation of all project activities and coordination of overall technical requirements, under the direction of the Telecommunications Division Manager.

(3) The major effort of the project administration element was the control of funds and project scheduling, and the associated progress reporting. The project administration responsibilities also included maintaining a central file

system and monitoring of documentation preparation, public information, and labor relations.

(4) The JPL Procurement Division provided the necessary contract negotiation and contract administration representatives to ensure the proper conduct of the procurements in accordance with standard policies and procedures established by NASA and JPL.

(5) The Project Technical Team, headed by the project manager, was composed of an administrative staff and five major engineering groups. Figure 4 is a simplified diagram of the Technical Team organizational structure, or work breakdown. Figure 5 functionally sets forth the Project technical organization, in keeping with the work breakdown structure.

3. Project Reporting

The basic reporting flow chart is shown in Fig. 6. The project administrative element assisted the Project Manager, serving as the focal point for preparation of project reports, and as an information center concerning all aspects of the project.

(1) Project Monthly Management Reports. The JPL Assistant Laboratory Director for TDA, based on his observations and on material provided by the JPL project manager, approved and forwarded a monthly Project Management Information and Control System Report to NASA OTDA, covering the current status of the overall project.

(2) Formal Progress Reviews. Formal progress reviews were conducted each quarter throughout the duration of the project. These reviews included comprehensive reporting and presentations of the construction of site support facilities, progress of the antenna construction, and associated efforts. These were conducted at JPL and served to detail the project status. JPL Management and NASA OTDA representatives attended all reviews.

Monthly reviews were held with the prime contractor, covering both technical and contractual or administrative matters outstanding. These were in addition to frequent liaison at the engineer level.

(3) Work Authorization Documents. All project implementations using Research and Development funding resources were also reported within appropriate equipment and operation Work Authorization Documents of the Deep

Space Network of JPL Tracking and Data Acquisition.

(4) Weekly Progress Briefs. Assigned project team engineers at overseas sites, at major subcontractor locations, and at JPL provided weekly briefs to the Project Manager. Such briefs were forwarded by the most expeditious means available, using communications facilities available to JPL. Quality Assurance and Contract Management activities, as applicable, were included in these reports.

(5) Project Weekly Brief. The Project Manager, based on his personal observation and progress briefs received, forwarded a Project Weekly Brief, through the DSIF Manager, to the Assistant Laboratory Director for TDA. The brief covered activities of the overall project that occurred during the period, planned activities during the forthcoming period, and such "red flag" items as existed.

(6) Subcontractor Reports to JPL. Major subcontractors involved in the project forwarded monthly reports under contractual arrangement. These reports included a project summary written by the contractor's project office. Adverse conditions as well as favorable conditions and results were reviewed by the Project cognizant engineers for correctness and information, and as a basis for such actions as might be required with respect to reported items.

(7) Weekly Photographic Reports. Photographs of project activities were (when available) forwarded weekly to NASA OTDA Headquarters, and JPL offices concerned with the project. These photographs helped to clarify project activities and to portray visually the project status.

(8) Project Schedules. Schedules were maintained for each of the major types of effort involved in the project, i.e., antenna instrument, site support facilities, and electronic equipment. Interfaces and relationships between the areas of effort were monitored continually. The primary technique utilized for detailed project monitoring was the IBM 1130-PCS program.

Master milestone charts for each of the two overseas sites served as a baseline plan for the project and was the basis for management summary assessment of status, progress and potential problems. Figures 7 and 8 show the milestone charts generated at the start of the project. Figures 9 and 10 indicate the actual milestone completion dates as experienced throughout the project.

III. UTILIZATION OF RESOURCES

A. FUNDS

Funding for the construction of the overseas antennas came from NASA to JPL in four separate categories, relating to the type of expenditure to be made:

(1) Forward Planning and Design Funds were for preliminary engineering studies, site investigation, and planning and similar engineering work carried on by outside engineering contractors preparatory to starting the project.

(2) Construction of Facility Funds for constructing actual permanent facilities such as the antenna, power generating plants, supporting utilities, certain antenna-mounted facilities, etc. These funds were expended by JPL through outside contractors who performed the actual manufacturing and construction tasks.

(3) Funds for paying the salaries of JPL employees assigned to the project.

(4) Research and Development Funds for equipment for the application of the facility to the various space exploration programs which are supported by the DSN.

All of these funds were provided through the governing contract between NASA and JPL in accordance with the standard contractual provisions, and were expended by JPL under established fiscal policies.

B. MANPOWER

The manpower required to conduct the overall project was made up primarily of JPL employees, with contracted personnel used for certain administrative and documentation functions. Major technical areas were monitored by cognizant engineers assigned to the project. Detail engineering, where drawings from the antenna at the Mars Deep Space Station were not used, in general was carried out by the engineering or manufacturing contractors, with JPL personnel primarily serving monitoring and coordinating functions.

C. MAJOR INDUSTRIAL PARTICIPANTS

1. Fabrication and Construction of the Antennas

The contract for the fabrication and construction of the antennas was awarded to Collins Radio Co., Dallas, Texas, following a standard NASA/JPL Source Evaluation Board procurement procedure. Collins Radio Co. in turn subcontracted certain major fabrication and construction tasks, maintaining a project staff to carry on technical, quality assurance, schedule, and contractual supervision over the subcontractors. The major subcontractors were as follows:

Alidade and alidade buildings	Precision Fabricators, Inc.
Azimuth and elevation gear drives	Philadelphia Gear Corp.
Hydrostatic bearing Mechanical components	Western Gear Corp.
Hydrostatic bearing and servo hydraulics	Hydranamics, Inc.
Radial bearing	
Runners and wear strips	Westinghouse Electrical Manufacturing Co.
Trucks	Western Gear Corp.
Elevation bearing assemblies	National Ship Corp.
Reflector structure	Coeur d'Alene Corp.
Reflector panels	Radiation Systems, Inc.

In addition, Collins Radio Co. used subcontractors for certain specialized portions of the field construction work as noted in Field Construction histories (Section V).

2. Tricone

The contract for the fabrication and installation of the tricones at both stations was let separately from the contract for the antenna construction, and was awarded to the Western Development Laboratory Division of the Philco Ford Corp. Installation of the tricones on the antennas was accomplished by them after the Collins Radio Co. site work was completed.

3. Supporting Facilities

The construction of supporting facilities including roads, water supply, sanitary facilities, power plants, etc. was managed by the U.S. Navy Bureau of Yards and Docks, Officer in Charge of Construction in Spain, and the Department of

Supply and the Department of Works of the commonwealth government in Australia, using local contractors.

4. Other Procurements

Other major procurements, including the diesel engine generator sets for the power plants and certain major antenna-mounted equipment, was procured by JPL in the United States and shipped to the site for installation by the appropriate contractor or operational organization.

In summary, the individual tasks required for the overall antenna project were divided up in a manner to minimize JPL involvement in the details of manufacture and construction and to give individual contractors well-defined tasks for which they could take complete responsibility.

IV. DESCRIPTION OF THE ANTENNA SYSTEM

A. GENERAL DESCRIPTION

This section provides an engineering description of the antenna system and its technical characteristics. Supporting facility services are also briefly described.

The antenna has a 64-m-diam 0.42 focal-length-to-diameter ratio paraboloidal reflector on a fully steerable azimuth-elevation mount using Cassegrain microwave optics. At the normal Network receiving frequency of 2.3 GHz, the half-power beamwidth of the antenna is 0.14 deg, the gain is 61.4 dB, and the total operating receiving system temperature at zenith can be as low as 16 K, depending on the microwave subsystem configuration. The antenna is designed to operate in an open and ambient environment. The mount is capable of azimuth motion of approximately ± 270 deg, and its normal elevation operating range is from +6 deg to +89 deg. The total weight of the antenna, including the pedestal, is 7.26 Gg (16,000,000 lb). The steerable weight above the azimuth axis is 2.722 Gg (6,000,000 lb).

An instrument (Master Equatorial) set on an independently supported tower at the intersection of the azimuth and elevation axes serves as a master pointing reference. The Master Equatorial can be precisely pointed in hour-angle/declination coordinates, and the antenna slaved to it through an optical link.

Figure 11 is a drawing of the antenna system showing the major components. A summary listing of the performance, operating characteristics and specifications of the antenna system is contained in Section VI.

B. PEDESTAL, INSTRUMENT TOWER AND CABLE WRAPUP

Figure 12 illustrates the pedestal, instrument tower, and cable wrapup.

1. Pedestal

The pedestal is a 25.6-m (84-ft) diameter concrete structure, two stories high, with a flat slab top with a concrete collar in the center. Operational working space, equipment, and facilities are contained within the pedestal.

Working space, equipment, and facilities are contained within the pedestal first floor. The second floor contains approximately 204.4-m² (2200 ft²) of space which is utilized for office accommodations. The antenna control and station electronics equipment is located in a separate operations building.

2. Instrument Tower

The instrument tower is a circular structure supported on an independent foundation which extends through the center of the pedestal building and the alidade structure, but is isolated from both. The lower portion of the instrument tower is concrete and extends to an independent footing below that of the pedestal. The upper section is steel and extends to the level of the alidade top weldments. The upper portion is completely enclosed in a wind and thermal shield that is mounted on and rotates with the alidade assembly. The top of the instrument tower is enclosed in an environmentally controlled room, and supports the Master Equatorial mount. The instrument tower independent foundation and thermal shielding provide a stable ground reference for the Master Equatorial mount.

3. Cable Wrapup

The cable wrapup assembly consists of flexible hoses and cabling and associate supporting components required for the distribution of water, coolants, electrical power, and signals between the pedestal-mounted equipment and equipment located on the rotating parts of the antenna

structure. The fixed end of the cable wrapup assembly is attached to the ceiling of the pedestal (second floor) within the cable wrapup room; the rotating end is attached to the alidade building roof beams.

Supporting components of the cable wrapup assembly include five spacer rings (four inner, one outer) which support and guide the hoses and cabling. Supporting components also include tie rods and cables which interconnect and support the individual rings. The inner rings are suspended from the alidade and are free to move, permitting a nominal ± 270 deg antenna rotation in azimuth. The outer ring (which also moves) is suspended from the pedestal.

C. ANTENNA MOUNT

The antenna mount Fig. is an azimuth-elevation type and consists of the bearing, structures, gearing, hydraulic power supplies, and motors required to accomplish movement of the microwave reflector about azimuth and elevation axes. Six major components of the structural-mechanical assembly that constitute the antenna mount are described as follows:

1. Alidade Assembly

The central structural element of the antenna mount is the alidade structure. The alidade structure is a large, framed pentahedron constructed of heavy steel wide-flanged structural shapes, and structural plate. The three points of the triangle-shaped base section are supported on the hydrostatic bearing assembly pads, thereby supporting and permitting the alidade (and all attached structures) to rotate about the azimuth axis. The two top weldments of the alidade structure support the elevation bearings. Other antenna elements mounted on the alidade assembly include the azimuth and elevation gear reducers and the alidade building. Personnel access stairs and platforms are also attached to the alidade assembly.

2. Hydrostatic Bearing Assembly

The hydrostatic bearing assembly is based on a 23.4-m (76-ft 8-in.) annular steel bearing and includes mechanical, electrical, and hydraulic equipment required to support the weight and permit the rotation of antenna moving parts on a pressurized film of oil about the azimuth axis. A stationary runner assembly is permanently attached to the pedestal and is completely enclosed in an oil reservoir. Three movable pad-and-socket assemblies are positioned on the stationary runner within the oil reservoir to support the three corners of the alidade base triangle.

Two hydraulic precharge units, an oil-conditioning network, three high-pressure power units and associated interconnecting plumbing supply pressurized oil through cavities in each bearing pad to form the relatively uniform oil film between the pads and the runner.

3. Radial Bearing Assembly

The radial bearing assembly is a roller-type bearing consisting of a steel runner and wear strip mounted around the concrete pedestal collar, and three truck assemblies. The truck assemblies are attached to the alidade wheel girders at 120-deg intervals about the azimuth axis. Each truck assembly has two rollers, supported top and bottom in roller bearings, that contact and ride on

the wear strip attached to the runner face. The trucks are preloaded to apply a steady force to the pedestal collar in order to prevent the moving parts of the antenna from sliding in a horizontal direction when subjected to wind loads.

4. Elevation Bearing Assembly

The elevation bearing assembly consists of two bearings mounted atop the alidade to support and provide tipping motions to the antenna reflector about the elevation axis. Each bearing consists of two roller bearings contained in split housings, supporting bases, a reflector support casting, shaft, seals, and alignment and adjustment components.

5. Azimuth and Elevation Gear Drive Assemblies

The azimuth and elevation gear drive assemblies (Fig. 13) consist of bull gears and multiple gear reducers to give the large reduction ratios required for the low rates of motion encountered in tracking spacecraft. For the azimuth drive the bull gear is mounted on the pedestal and four gear reducers, mounted on the alidade, mesh with it to move the alidade about the azimuth axis. For the elevation drive there are two bull gears mounted on the tipping structure and four gear reducers mounted on the alidade, with two meshing with each bull gear. The use of two bull gears in elevation was required to provide an opening through the alidade for the instrument tower, while maintaining the symmetrical structure necessary to meet the reflector deflection requirements. In each case the gear reducers are pivoted to the alidade to permit the output pinions to follow the eccentricities inherent in the very large bull gears. The mesh between the output pinions and the bull gears is maintained by backup rollers on the gear reducers that ride on machined surfaces of the back side of the bull gears.

The bull gear assemblies are made up of L-shaped segmental spur gears machined from heavy steel weldments. Each gear reducer assembly consists of four stages of gear reduction, mounted in a heavy welded steel housing, with an integral output pinion and backup roller. There are provisions for mounting two hydraulic motors (one for driving and the other for counter torque to eliminate backlash), a spring-set hydraulically released brake and two lubrication pumps to assure proper lubrication of all bearings and gears at very low speeds.

6. Servo Hydraulics Assembly

The servo hydraulics assembly (Fig. 14) consists of the hydraulic equipment necessary to move the tipping structure about the elevation axis and the alidade about the azimuth axis. The servo hydraulics assembly comprises hydraulic drive motors and counter torque motors (four of each type for each axis, one of each type for each gear reducer); two redundant low-pressure and two high-pressure hydraulic power units; two control consoles; an oil-conditioning network; brake assemblies; and electronic control and electrical power interfaces. The high-pressure pumps are pressure compensated to provide fluid flow at a constant pressure regardless of the flow demand, within the capacity of the pumps. The high-pressure pumps are driven by 149-kW (200 hp) electric motors and operate at a pressure of 18.6 MN/m^2 (2700 lb/in.^2). The actual rate control of the antenna is through electrically controlled

servo valves, two in parallel for each axis, which control the flow to the fixed displacement hydraulic motors in response to electrical signals from the servo-electronic circuits.

A drive and a countertorque hydraulic motor is mounted on each gear reducer. The hydraulic circuit is arranged so that under normal wind loads (less than about 56 km/hr (35 miles per hour)) the motors on one pair of gear reducers drive in one direction, while this motion is resisted by the counter-torque motors of the other two gear drives. When the direction is reversed, the former driving gear reducers resist the motion, while the former resisting gear reducers provide the driving force. With this arrangement each output pinion bears on the same side of the bull gear teeth regardless of rotational direction, thus eliminating the back lash which might otherwise exist. In high-wind conditions the circuitry provides for the resisting gear reducers to shift their output torque and provide additional driving force.

D. TIPPING STRUCTURE

The tipping structure of the antenna (Fig. 15) include the primary reflector backup structure, primary paraboloidal reflector surface, secondary hyperboloidal reflector surface, supporting quadripod structure, Cassegrain multiple feed cone support, and the intermediate reference structure.

1. Primary Reflector Back-Up Structure

The primary reflector structure is a 64-m (210-ft) diameter paraboloidal space frame supported by a truss-type backup structure. The space frame is a network of 48 rib trusses, and 10 circular hoop trusses. The paraboloidal space frame supports the primary reflector surface panels. The backup structure is formed by two elevation wheel trusses, supported and braced by a tie truss between the elevation bearings. Elevation wheel trusses support the elevation gear segments and counterweights which statically balance the tipping assembly about the elevation axis.

2. Primary Reflector Paraboloidal Surface

The surface of the primary reflector comprises 552 individual panels contoured from aluminum sheets riveted to precisely formed aluminum frames. The panels are affixed to the reflector backup structure with adjusting screws which are accessible from the exposed surface of the reflectors. The design is such that loads in the backup structure are not transmitted into the surface panels. The panels form a solid reflecting surface over the inner half radius of the reflector, and a perforated surface (50% porosity) over the outer half radius.

3. Quadripod Structure

The quadripod supports the hyperboloidal subreflector. It is a tubular space frame structure of four trapezoidal shaped legs meeting in a large apex space frame. The four legs are supported at the hard points of the rectangular girder in the primary reflector structure. The quadripod also supports rigging for handling the Cassegrain feed cones, the subreflector, or other heavy equipment being brought to or from the reflector.

4. Hyperboloidal Subreflector

The subreflector is a 6.1-m (20-ft) diameter, precision hyperboloidal reflecting surface with a

305-mm (12-in.) skirt for special optimization of the microwave feed system. It is a hub and back-up space frame structure with linear adjustment capability by remotely controlled electric motor and screwjack assemblies.

5. Tricone Multiple Cassegrain Feed System

The Cassegrain geometry was chosen to be similar to the 26-m (85-ft) antenna Cassegrain design, thereby allowing interchangeability and standardization of the feedcone structures.

Figure 16 shows the overall tricone configuration. The three feedcones are mounted by quick disconnects on a three-module support assembly which houses various ancillary equipment. The feedcones themselves are similar to standard DSN feedcones.

Module I of the feed support is designed as an open-space truss in order to provide optical line-of-sight to paraboloid surface panel targets.

Module II of the feed support is a cylindrical section designed to house transmitter equipments. Module III of the feed support has tapered sides in order to minimize the RF blockage and still provide space for mounting standard-size DSN cabinets.

6. Intermediate Reference Structure

The intermediate reference structure is a steel truss structure attached to the primary reflector center hub, and centered on the primary reflector boresight axis. The intermediate reference structure extends to the master equatorial room atop the instrument tower to provide mounting for an optical package perpendicular to the primary reflector boresight axis.

E. SERVO AND ANGLE DATA SYSTEM

1. Servo Control Assembly

The servo control assembly provides centralized control over the rotating, tipping, and remotely operated mechanical parts of the antenna structure; visual indications of antenna rate and position, and the status of controlled components.

2. Angle Data Assembly

The angle data assembly (Fig. 17) provides and controls a precisely aligned equatorial mount (Master Equatorial) that serves as the primary angle reference for control of antenna position; a secondary angle reference in azimuth and elevation coordinates; and digital readout of antenna position in hour-angle declination, and azimuth elevation coordinates.

3. Master Equatorial Assembly

The Master Equatorial assembly is a precision astronomical telescope type of mount, carrying a mirror and autocollimators, that establishes an optical line of site of accurately known angular orientation. Remotely controlled servo drive mechanisms provide rotation about its axes and precision readouts make the orientation of the axes accessible. The motions of the mount are in hour angle and declination coordinates. An autocollimator mounted on the intermediate reference structure, and operating against the Master Equatorial mirror, measures the angular displacement of the reflector axis from the optical line of sight established by the Master Equatorial, and sends error signals to the servo control system which, in turn, controls the antenna rate and position through the servo hydraulic assembly.

The intermediate reference structure optical assembly is mounted to the underside of the IRS, which is attached to the reflector center hub structure.

Operational control and monitor of the servo and angle data systems is centered in a console in the station control room. At this console are the controls and displays required for the servo and angle data systems, the hydrostatic thrust bearing, and the positioning of the antenna sub-reflector. The servo control also includes the control room displays of an area surveillance closed-circuit television system for sighting possible hazards to antenna motion, and a wind speed and direction display for operator information on environmental conditions.

F. SUPPORTING FACILITIES

Facility services needed to operate and maintain the antennas are integrated into the overall design. These include: electrical power and distribution; heating, air conditioning, and ventilating; water distribution; general and emergency lighting; fire protection; installed safety devices; sewer system; grounding; and general support equipment.

1. Electrical Power and Distribution

Both sites have a power house which is divided into two sections; A and B. The A sections were the power source for the original 26-m antennas at each station, while the B sections were constructed to house the additional power required for the 64-m antenna. Section A in Australia houses four 500-kW diesel-driven generators. Section A in Spain contains one 150-kW, two 350-kW and two 500-kW diesel-driven generators. Power house section B at both sites are equipped with four 750-kW diesel-driven generators.

The electrical distribution equipment for the antennas includes three electric power substations (two in the pedestal, and one on the alidade), four motor control centers, two high-voltage motor starters, controller and relay assemblies and junction boxes for the high-pressure servo pump motors (which operate on 2400 Vac); and associated interlocks, interconnecting cabling, wiring, and associated terminal junction boxes.

One servo high-voltage junction box is mounted on the second floor of the pedestal building; the other is in the alidade machinery room. The two servo high-voltage junction boxes are interconnected through the cable wrapup assembly. The alidade machinery room also contains the servo motor pump controller assembly relay cabinet and starter transformers.

Located downstream from the motor control centers are various terminal junction boxes for distribution of electrical power to specific use areas. Electrical power is distributed at 120, 208, 480, and 2400 V, three-phase 60 Hz. The electrical distribution equipment also includes circuit breakers interconnected to the servo control assembly and the angle data assembly components located in the control building control room.

2. Heating, Air Conditioning, and Ventilating

Heating, air conditioning, and ventilating for the antenna is provided by three contiguous networks of ethylene-glycol coolant, chilled water, and conditioned air handling and distribution

equipment; two evaporative cooler assemblies interconnected to the site domestic water distribution network; and exhaust fans placed in the outer walls of the alidade bilge area. The cooling tower, which is part of the liquid coolant distribution network, is mounted outdoors near the pump house. All of the equipment conforms to high quality commercial standards. The ethylene-glycol coolant network is a closed loop consisting of two direct-driven 30-kW (40 HP) pumps mounted within the pump house; a double-cell cooling tower; and an insulated network of piping and valving. Through the network piping, the coolant network interfaces with condensers of the chilled water distribution network, and with heat exchangers mounted near the hydrostatic bearing pads and the servo hydraulics.

The chilled water network is a closed loop consisting of two coolant-cooled chillers with tube-type condensers, refrigerant compressors, associated electric motors and control valving and gauges located within the pedestal building; and an insulated network of piping and valving. Through network piping, the chilled water distribution network interfaces with three air-handling units which are mounted on the first floor of the pedestal, atop the alidade building, and in Module I of the Cassegrain cone support structure. The nominal temperature of the chilled water is 4.4°C to 10°C (40° to 50°F).

The conditioned air-handling network is contiguous to the chilled water distribution network, and consists of three large air-handling units and associated ducting. The ducting extends to all work areas throughout the antenna structure to provide conditioned cooling or heating air for personnel and equipment. Electrical filament heaters with associated fans, controls, and thermostats are mounted within the ducting. The air-conditioning, heating, and ventilating equipment also includes an evaporative cooler mounted on the roof of the alidade building and exhaust fans located in the alidade bilge area.

Because of its severe environmental requirements, the master equatorial room has a separate air-conditioning system. It includes two self-contained air-conditioning networks with associated automatic controls and ducting. The two networks are independent, except for the ducting, to provide complete backup protection. Electrical filament heating components are mounted within the ducting. One of two networks operates at all times to maintain an ambient temperature within the room of 21 ± 1°C (70°F). The operation and status of the air-conditioning equipment is monitored remotely at the angle data assembly Master Equatorial control panel within the operations and control building control room.

3. Domestic Water System

The antenna domestic water system consists of hot and cold water plumbing with flow control valving and pipeline vibration isolators. The water distribution network is gravity-fed, and interfaces with the site water system. It extends to the pump house, the cooling tower, the pedestal, and via the flexible hoses in the cable wrapup assembly to various locations on the alidade.

4. General and Emergency Lighting

General lighting on the pedestal and antenna is provided by standard incandescent lights, flood lamps, and quartz-iodine lamps mounted externally

on the antenna structure. The pedestal building and all structural elements are sufficiently lighted so that the surveillance television cameras can be effective at night. The general lighting equipment also includes double-weatherproofed, aviation-type obstruction light fixtures, with two aviation red globes each, mounted at the perimeter of the primary reflector surface at 90-deg intervals and at the apex of the quadripod.

There is emergency lighting equipment inside the pedestal and alidade buildings, and at various locations about the antenna structure. Each unit is a package type with two sealed-beam, 25-W lamps. Units mounted outdoors are weather-proofed.

5. Fire Protection

There are comprehensive fire alarm and fire water distribution networks in the antenna facility. Also, there are fire extinguishers mounted throughout the antenna pedestal and structure and in the pump house.

The fire alarm network includes two fire alarm stations, 29 smoke-sensitive detectors, and five manually operable fire alarm boxes. The fire alarm stations include red and white indicating lights, override controls on the antenna operation, warning buzzers, safety climbing belts, and a portable emergency electrical power pack. One fire alarm station is in the pedestal second floor near the office area, the other is in the alidade control room. The fire alarm stations are connected to the smoke-sensitive detectors and to the manually operable fire alarm boxes.

The smoke detectors are ionization-type units, and are mounted on the ceilings and under the floors of work areas in the pedestal and in the alidade building and within the air conditioning ducting. The ceiling-mounted detectors have integral red indicating lights; the under-floor and ducting detectors are interconnected to red indicating lights at the associated fire alarm station. The manually operable fire alarm boxes are mounted

throughout the antenna structure.

The fire water distribution network includes ceiling-mounted fire sprinklers, fire hoses, an auxiliary pump to increase water pressure, and associated controls, piping, and valving. The fire sprinklers are located in all-enclosed work spaces in the pedestal and alidade areas, and the fire hoses are mounted in steel cabinets about the antenna structure. Fire extinguishers are mounted within the fire hose cabinets, and on the walls within enclosed areas. All user fire protection equipment is painted bright red, and is in well lighted locations (Fig. 18).

6. Installed Safety Devices

For the protection of personnel and equipment on the antenna structure, there are many permanently installed safety devices. The devices include antenna rotation warning horns, electrical grounding equipment, warning signs indicating hazardous areas, handrails, and caged stairways. Emergency antenna stop pushbuttons are mounted to the electrical and hydraulic assemblies, and at key locations throughout the antenna structure. An emergency stop bar is mounted to the front of the rotating stairway.

Obstruction and rotation lighting devices are mounted on the antenna structure. Also, standard black line telephones are placed at key points in the pedestal and on the structure, and there is a loudspeaker network used to notify all personnel that the antenna will be activated or shut down, or of any emergency situation.

7. General Support Equipment

The antenna support equipment consists of various electrical, pneumatic, and mechanical service hoists; an electric motor-driven air compressor assembly, and a gas-operated steam cleaner assembly with interconnecting plumbing. Some service hoists are permanently mounted to the antenna structure; others are capable of being attached to selected locations about the antenna as needed.

V. FABRICATION PHASE

With the exception of certain items fabricated in Australia, outlined in Section VII, all of the antenna components were fabricated in the U. S. and shipped to the construction site for erection. Fabrication within the U. S. permitted quick communication between JPL, Collins Radio Co. and the various subcontractors in maintaining the quality control program and in the resolution of technical problems which arose. As outlined in Section III, the fabricating subcontractors were located in all parts of the United States. Under the terms of the prime contract JPL had approval of certain main subcontractors. Others were selected by Collins Radio Co. through their normal procurement and subcontracting procedures. The detail drawings were basically those made by the original fabricators of the 64-m antenna at the Goldstone DSCC, reflecting their own drafting and manufacturing practices.

Three of the major subcontractors, Philadelphia Gear Corp., National Ship Corp., and Precision Fabricators, Inc., had furnished the same assemblies for the 64-m antenna erected at the Goldstone DSCC in 1963-1965 and were completely familiar with the work. Other contractors had done little or no previous antenna work for JPL, and in at least one case were operating in an area where they had little experience. Thus a considerable amount of liaison with JPL technical and Quality Assurance personnel was required for the interpretation of drawings and specifications, in the resolution of ambiguities, and in the problems arising from various manufacturing errors or accidents. In discussing these problems it is not intended to evaluate individual contractors. The end result was that the completed antennas operated within the specified parameters.

While a detailed review of the entire manufacturing phase of the project is not appropriate for this report, a discussion of some of the problems encountered and their resolutions will indicate the scope of the fabrication effort and the types of difficulties encountered in a project of this magnitude.

A. HYDROSTATIC BEARING RUNNER AND RESERVOIR ASSEMBLY

The hydrostatic bearing runner is formed of 11 segments which make up into a ring approximately 23.4 m (76 ft 8 in.) in diameter, with a cross section 1.17 m (44 in.) wide by 178 mm (7 in.) thick. The principal problems in the manufacture of these segments are maintaining the desired flatness—0.076 μm (0.003 in.) over any 1.5-m (5-ft) length—and holding the steps in the top surface across the joints to not more than 25 μm (0.001 in.). The subcontractor was particularly well equipped for this type of manufacture.

Three distinct problems arose. First, a strike in the fabrication plant, coupled with other high priority jobs in work, caused a slippage in schedule which was overcome only with heroic efforts to prevent a slippage in the construction work. Secondly, the segment outer radius, which was flame cut to size at the steel mill source, was found to be about 1 in. out of tolerance on receipt in Everett, Wash. This affected the circularity of the reservoir wall and caused problems with the seal between the outer reservoir wall and the rotating structure of the antenna. Schedule considerations prevented reworking these or obtaining new segments, and adjustments were made in the field to provide for proper seal action. The third problem was the lack of full understanding on the part of the manufacturing personnel of the way the bearing functioned, and how this related to the drawing tolerances. Several errors in the first runner, for the Australian antenna, were made which had to be corrected, again affecting schedule. The second runner, for the Spanish site, was manufactured without any other significant difficulties.

B. RADIAL BEARING

The radial bearing trucks were manufactured without serious difficulty. The most serious problem encountered was the fabrication of the runner wear strips. The original design called

for these to be machined in the flat and then formed to the proper radius to mate with the radial bearing runner. It was found that an anelastic deformation occurred during the forming that gave a concave outer surface against which the truck wheels bore, and a poor contact pattern between the wear strip and the runner. This was corrected first by placing shims between the wear strip and the runner to improve the contact, and then by machining the outer surface of the wear strips while assembled on the runner. Since the runner is 30 ft in diameter, this required the use of a very large (40-ft) boring mill.

This method of fabricating the wear strip is not satisfactory and caused problems both on the original 64-m antenna at the Goldstone DSCC in California and on the two overseas antennas. On any future antenna a method has been developed at JPL that will insure machining the wear strips in the final arc shape.

C. ALIDADE

The alidade is a very large, very heavy structure. These were fabricated and trial erected in the fabricator's plant prior to shipment overseas. The principal problems arise from the need to align accurately the connection points for the azimuth and elevation drives and for the elevation bearings. The alignment was made more difficult by the inaccessibility of certain work points, and by the fact that none of the member interfaces were machined, being as-rolled steel plates or sections. Due to schedule problems the alidades were not completely preassembled in the shop and some rework became necessary in the field. In future antennas, provision should be made for more accessible working points for alignment, and consideration should be given to machining the interfaces between principal members.

D. AZIMUTH AND ELEVATION GEAR DRIVES

The azimuth and elevation gear drives were manufactured by the same subcontractor that made the similar components for the antenna at Goldstone DSCC, and relatively little difficulty arose in this effort. However, it was found in the field that, due to warpage of the elevation bull gear segments weldments, which was not contemplated in the detail drawings, interference arose between portions of the gear boxes and the bull gears. This was found before any damage occurred, and corrections were made on-site.

E. SERVO AND HYDROSTATIC BEARING HYDRAULIC

The servo and hydrostatic bearing hydraulic units were assembled by one manufacturer subcontractor. He showed considerable care in this detail design work and in the documentation. However, two problems arose. First, he did not have qualified high-pressure piping welders, and it was necessary to train and qualify several people to perform this end of the project. Then, part way through the project the Los Angeles facility was closed, and the entire project was transferred to a plant near Seattle, causing a trauma in the schedule and coordination. In final analysis, his work was completed on time and operated properly in the field.

F. TIPPING STRUCTURE

The tipping structure was fabricated in a relatively small shop, with most of the actual trial erection being conducted outside. The trial erection of backup structure and elevation bull gear wheel, which are made up of very heavy structural members; was made on special towers so that structure was in the position related to the zenith position of the reflector. However, in the trial erection some of the weight of the structure was supported by chocking from the ground, so that the gravity deflections were not reproduced. This may have caused problems in field erection, and in a future antenna consideration should be given to a trial erection truly simulating the load condition on the antenna. Due to a misinterpretation of detail drawings, a large number of welds in the reflector structure were omitted. This was corrected in the field at considerable cost in dollars and time.

G. REFLECTOR PANELS

The fabrication of the reflector panels caused the most difficulty of any of the components, from the points of view of technical liaison and quality control. The subcontractor apparently had little previous experience with sheet metal fabrication to close tolerance and went through an extensive learning curve before producing satisfactory parts. Many had to be reworked causing considerable time delays and coordination efforts. The paint specified required very careful application, and he experienced a great deal of difficulty in achieving good quality. Weather problems caused some delays, and caused difficulties in obtaining proper paint application.

H. ELEVATION BEARINGS

The elevation bearings subcontractor also furnished the elevation bearing assemblies for the 64-m antenna at Goldstone DSCC and was familiar with the fabrication problems. Only minor difficulties occurred, and these were resolved without impairing the construction schedule or the antenna performance.

I. INSTRUMENT TOWER

The instrument tower upper section, which is a steel cylinder, was fabricated in segments for each station, for assembly on-site into the completed cylinder. On assembly it was found that the cylinder eccentricity was such that the instrument tower and the rotating windshield on the alidade interfered during azimuth motion. This appears to have arisen from a misunderstanding of the detail drawings and of the actual configuration of the structures. Considerable field modifications were required to correct this problem.

J. SUMMARY

Certain conclusions, applicable to future antenna construction projects, can be drawn from the experience gained on this project and are summarized:

- (1) Schedule coordination is absolutely vital, particularly for components which must be fabricated here and shipped overseas to arrive on a construction site at the proper time for erection.

(2) Despite checking and cross checking, and updating redline corrections, detail drawings may contain errors and ambiguities which must be resolved promptly by competent technical personnel to prevent schedule delays. Drawings made by one fabricator, for use in his own facility, may be misunderstood in another fabricator's plant.

(3) Fabrication and quality assurance capabilities of contractor/subcontractors must be determined before contracts are let.

(4) Quality Assurance efforts are necessary not only to ascertain that parts are

manufactured per drawings to meet the final performance requirements, but also to assure that errors do not occur undetected, to arise at a later phase of manufacture or construction and cause unexpected schedule slippage and field reworking; and to assure that corrective actions are promptly defined and properly carried out.

(5) When a large portion of the fabrication is subcontracted by the prime contractor, it should be clearly defined that there must be effective liaison between the contractor and JPL, that JPL will have rights for visitation of subcontractor's plants and inspection of work in process.

VI. QUALITY ASSURANCE

A. GENERAL

The function of the Quality Assurance Program was to assure that all material and construction of the antennas was in accordance with the contractual drawings and specifications. This effort can be divided into the following areas:

1. Raw Material Certifications

Raw material certifications were required for all materials except those specified as being of commercial quality. These certifications included chemical analyses, and test data as required by governing specifications. A file was maintained of all certifications required by the contract specifications.

2. Compliance to Drawings

All manufactured components were inspected to assure that the final part agreed with the detail drawings. In addition, where applicable, manufacturing processes were monitored to assure that they conformed to governing specifications.

3. Disposition of Defective Material

A system of Vendor's Defective Material Reports (VDMARs) was maintained under which defective material was disposed of by scrapping, reworking, or using as manufactured. These reports recorded the type of defect, the disposition, and the reason therefore.

4. Inspection of Assembly and Construction

Inspection was maintained throughout the construction of the antennas to assure that: (1) the antennas were constructed according to the drawings and specifications, (2) specified procedures and tests were carried out, and (3) the specified alignments and test data were properly taken and recorded.

B. ORGANIZATION

When the project was set up it was intended that the detail quality assurance program would be

conducted by the contractor, in accordance with a plan developed by him and approved by JPL. The JPL function was conceived primarily as that of monitoring the contractor's program. The contractor in turn passed much of the detail quality assurance effort on to the subcontractors, assuming a monitoring function himself.

JPL staffing of the project included the DSN Quality Assurance Manager on a part-time basis, an average of four JPL Quality Assurance engineers monitoring fabrication in the United States and one resident Quality Assurance engineer at each antenna construction site. This group maintained surveillance of the contractor and subcontractor programs, maintained records of material certification, test data and Vendor Discrepant Material Action Request actions and acted as liaison between the contractor and cognizant technical personnel on Quality Assurance matters.

C. EVALUATION OF THE QUALITY ASSURANCE PROGRAM

The Quality Assurance Program was not an unqualified success for a number of reasons not foreseen at the start of the project. Principal among these were the following:

(1) The contract drawings and specifications were sometimes ambiguous with respect to process or inspection specifications, leading to lost time in the resolution of numerous differences of interpretation. This was partly due to the differences in practice between the contractor who made the detail drawings and the actual subcontractor for this project.

(2) By the time the prime contractor's quality assurance plan was approved by JPL many of the major subcontracts had been let, and some material ordered, without reflecting the final approved plan. This led to contractual difficulties in enforcing the final approved plan on the subcontractors.

(3) There was a lack of understanding on the part of the prime contractor as to the depth of quality assurance required to meet the contractual as well as the antenna performance requirements. This led to difficulties when it became necessary to enforce the detailed provisions of the contract.

(4) Some of the subcontractors were not adequately staffed to carry on a quality assurance program of the depth required by this project. This led to contractual problems between the subcontractors and the prime contractor and between the prime contractor and JPL. The prime contractor was compelled to carry on some in-plant inspection at subcontractor's facilities, and this effort was beyond the capacities of his staff.

(5) Because of lack of detail inspection at the point of original manufacture some material progressed through the subcontractor's plants to the field sites before defects were discovered. In some cases the force of schedule requirements led to the acceptance of less than optimum material, and in others schedule slippage and excessive costs arose from the need to rework material at a late stage of fabrication or construction.

(6) There was difficulty in finding quality assurance engineers qualified in some of the areas of heavy fabrication and construction. This was particularly true in such areas as heavy structural and pressure vessel welding, painting, and heavy field construction.

(7) In view of the experience on this project, the following recommendations are made for future projects of this type:

- (a) The drawings and specifications must be thoroughly coordinated with the Quality Assurance documents to assure complete inter-referencing. Furthermore, the individual specifications should be reviewed for completeness and applicability.
- (b) The contract should give JPL full access to the contractor's and lower tier subcontractor's facility at all times. The JPL role should be expanded to include direct monitoring of all subcontractor quality assurance programs, as well as direct inspection of material in the subcontractor's facilities. This will require a more extensive staffing by JPL of the quality assurance function.
- (c) Quality assurance engineers should be specially trained in their areas of responsibility to assure a thorough knowledge of the processes they are monitoring.
- (d) There should be a functioning quality assurance program in existence before any subcontract or material purchases are initiated.

VII. HISTORY OF FIELD CONSTRUCTION - AUSTRALIA

A. INTRODUCTION

This section of the report describes the construction of the 64-m antenna near Canberra, Australia, that began on Nov. 3, 1969 and was completed in July 1972. Other significant milestones include the first azimuth rotation, which occurred on June 12, 1971, and the first elevation rotation, which occurred on January 28, 1972.

The construction site was located within the existing 26-m station area which is 22 road miles from Canberra in the Australia Capital Territory. The surrounding area is used for sheep and cattle grazing and is sparsely populated (Fig. 19).

Collins Radio Co. (CRC) of Dallas, Texas, was the prime contractor, and the company's on-site project manager and most engineering personnel were from Dallas. The major construction effort was accomplished by local workers from the Canberra area who were either on the CRC payroll or were employed by local subcontractors. The indigenous labor force was well qualified to perform all construction tasks.

The main structural elements and drive systems were all manufactured in the U. S. and shipped to the site. However, local Australian materials were used for most of the general construction work and all architectural finishes.

CRC and the subcontractor personnel had good safety records, with no serious injuries occurring.

JPL maintained a resident engineer, an alignment engineer, and a Quality Assurance engineer on-site for the duration of the project. Daily construction logs are on file documenting job progress, manpower, and weather conditions for the entire construction period.

B. CONTRACTOR SITE ORGANIZATION

1. Organization in Residence

The Collins Radio Company of Dallas, Texas, worked through its Australian subsidiary, Collins Radio Co. (Australasia) Pty, Limited, which was headquartered in Melbourne. The on-site management and site engineers were from the Dallas office. The U.S. personnel consisted of a site manager, field engineer, quality assurance engineers, servo engineer, servo hydraulics engineer, and an alignment engineer. In addition, there were periodic visits from the Dallas office of the Project Manager.

2. Subcontractors

a. Concrete Design and Testing. The Snowy Mountain Authority was employed by Collins Radio Co. to approve the aggregates, prepare design mixes, do all batch testing, and supervise the batch plant concrete placement. This organization has a worldwide reputation for dam construction and proved well qualified for the project. In addition, Kinnard-Hill of Canberra, consulting engineers, assisted in the work.

b. Soils Testing. All soils testing was accomplished by Coffey and Hollingsworth of Canberra. Few, if any, problems were encountered in this area.

c. Concrete Supplier. Ready Mixed Concrete, Ltd., of Canberra erected the batch plant on-site and furnished all concrete. This organization was large, responsive, and well qualified.

d. Electrical Work. O'Donnell Griffin installed all electrical work, including underground ducts and manholes. This firm is one of Australia's

lia's largest and did most of the major facilities in Canberra. The company had no difficulty following U. S. standards where required.

e. Painting. All painting was subcontracted to E. H. Johns. This firm got off to a slow start, and some of the work that could have been done on the ground was accomplished "in the air." During the later portions of the job, proper staffing enabled them to meet the schedule.

f. Roofing. Allied Asphalt Co. installed the alidade building buildup composition roof.

g. Metal Decking and Siding. H. H. Robertson furnished and installed all metal decking and siding. This work was accomplished by only two men, and the task took much longer than Collins Radio Co. had anticipated.

h. Antenna Elements Transport. Brambles, Ltd., of Sydney handled all customs clearance and haulage to the site of the U. S. fabricated antenna elements. This firm had first-class equipment and delivered all materials with efficiency.

i. Mechanical Work. Mechanical work, including plumbing, air conditioning and fire sprinklers, was not subcontracted but was installed under the direct supervision of Collins Radio Co.

3. CRC Interface with Local Agencies

CRC cooperated with the JPL DSN Resident to obtain customs clearances. They also negotiated with the Commonwealth of Australia Safety Organization (Bureau of Cranes and Scaffolding). In addition, Collins Radio Co. had informal contacts with the station director. All these interfaces were tactfully handled by Collins Radio Co. resulting in good working relationships.

C. SITE CONDITIONS AND PHYSICAL PLANT

1. Site Conditions

The Station is situated 11 miles by air southwest of Canberra in the Tidbinbilla Valley. The geodetic location is 35.4° south latitude and 149.0° east longitude. The Tidbinbilla Valley lies along the northeastern edge of the Australian Alps. A long northwest trending ridge forms the eastern edge of the valley and provides primary shielding from the developed area around Canberra. The area of the valley is about seven square miles. The major bedrock is coarse-grained granite overlaid by heavily weathered material.

Extensive geological, geophysical, and foundation investigations were conducted at the site by Donald R. Warren Co. of Los Angeles. These investigations are contained in the detailed report dated October, 1967. The report indicated that a decomposed granite bedrock would be encountered at an approximate 5.5 m (18 ft) depth. The foundation excavation for the pedestal and instrument cover verified the accuracy of the foundation investigations.

There were two access roads to Tidbinbilla Valley from Canberra. One was a paved road, known as the Cotter Road, and the other was a partially unsurfaced one known as the Point Hut Road. The Cotter Road was used for personnel access and light hauling since it was shorter (33 km (24 miles)) and paved. The Point Hut Road (48 km (30 miles)) was used for heavy hauling,

since the bridge and stream crossing were adequate for heavy hauls. One bridge within the Tidbinbilla Valley was shored by the Department of Works to accommodate the heaviest haul (the 59 Gg (65 tons) of the elevation bearings).

The existing antenna facilities on-site at start of construction consisted of the 26-m antenna, antenna support building, operations building, power plant, maintenance shops, and messing facilities. On-site utilities included water supply, power generation, and distribution sewerage collection and primary treatment. Except for the messing facilities, Collins Radio Co. made no use of the station facilities.

JPL installed a weather station on the construction site early in the project. On a continuous basis this station recorded temperatures, wind velocity, and rainfall. The data were summarized on the daily logs prepared by Collins Radio Co.

The higher temperatures occurred during December, January, and February and ranged from 27°C (80°F) to the 38°C (100°F); some temperatures above 38°C (100°F) were also recorded. Low temperatures occurred from June through September when the average minimum temperatures were in the freezing range. Temperatures below freezing were common.

Low temperatures created problems in the placement of the pedestal concrete immediately below the haunch. This pour is discussed in Section IV.

The average rainfall in the Canberra area is approximately 2 in. per month year round. Rainfall generally did not affect construction progress. However, during the placement of the instrument tower footing on January 4, 1970, a very localized cloudburst, 2.54 cm (1 in.) of rain in 40 min caused concrete placement to be stopped in the middle of the operation.

While fairly heavy wind gusts, up to 93 km/h (50 mi/h) occurred during construction, they were not of sufficient frequency to affect the schedule and caused no serious difficulties.

2. CRC Physical Plant

a. Construction Area and Interferences. Adequate construction area was furnished to CRC for all construction activities. CRC properly fenced the area to maintain personnel access control. Approximately midway in the project it was necessary to reduce the established construction area to allow for construction of a portion of the tunnel by the Department of Works. CRC maintained that this action increased CRC costs. No other construction interferences occurred.

b. Offices, Warehouse and Utilities. The initial CRC office space was approximately 100 m² (1000 ft²). This space was doubled midway through the project. CRC erected a 100-m² (1000 ft²) prefabricated metal warehouse for the storage of construction materials. Tool sheds and other minor structures were also furnished.

A well was drilled on-site for supplying water for construction. Commercial power at 11 kV, 50 Hz was brought in from a distance of 1.6 km (1 mile), and a 250-kVA substation was established on-site. In addition, two 300-kW 60-Hz portable diesel generators were brought for antenna test and operation.

c. Importation and Transportation. The importation, exportation, and accountability of all materials were very important since all imports were duty-free. Importation forms were prepared by the contractor. NASA/DOS approved the importation before the forms were sent to the customs authorities.

Customs clearances and hauling from the Sydney docks were handled by Brambles, Ltd. These functions generally proceeded smoothly. Materials normally arrived in good condition with little damage. Some rusting of the primary reflector structure was experienced. However, this was primarily due to an inadequate shop coat. The alidade structure was coated with heavy salt spray that had to be removed prior to painting.

Materials were not generally uncrated until the need for the material arose, unless crate damage indicated possible material damage. This procedure protected the material to storage but did involve some schedule risk.

Receiving inspection was conducted by Collins Radio Co. on all materials. If no damage was noted, the shipping documents were stamped by Collins Radio Co. Quality Assurance engineers. If damage was noted, a Field Inspection Damage Report was prepared by Collins Radio Co. indicating the proposed repair, which was subsequently approved by JPL.

d. Heavy Equipment. The following is a description of the Collins Radio Co. on-site construction plant.

The guyed derrick used for erecting major antenna elements was fabricated in the U.S. and shipped to the site. The derrick had a capacity of 271 Gg (300 tons) at 7.6 m (25-ft) reach and 59 Gg (65 tons) at 50 m (165-ft) reach. The latter value was established so that both elevation bearings could be placed if necessary, without antenna rotation. The derrick tower, 95 m (315 ft) high, was supported by four 61-m (200-ft) intermediate guys and seven 305 m (1000-ft) guys. The hoist engine was a 500-HP General Motors diesel.

Work on the guy anchors started in May 1970, and the erection of the derrick took place from September to November, 1970. At the completion of the project, the derrick hoist, sheaves, and castings were shipped back to the U.S. The structural steel was cut up for shipment to Japan. These actions were required by the Commonwealth of Australia under the customs agreements. A 70-ton truck crane was on-site for the entire duration of the project. Collins Radio Co. rented other construction equipment as required. This equipment, consisting of excavators, trucks, sheep-foot rollers, pumps, and similar equipment, was generally available in Canberra.

D. CONSTRUCTION

1. Site Grading Excavation and Backfill

Initial site grading and excavation was accomplished with a motor grader, plus a front-end loader and trucks. An area along Larry's Creek was designated as a spoil area after consultation with the Department of Works and the Network Support Facility.

The instrument tower excavation was carried to a depth of 8.5 m (28 ft). The original intent was to cut neatly the excavation and gunite the

walls to make up the outer form. This proved impractical because of the collapsing in of the walls. The decomposed granite dug relatively easy with a backhoe. A clamshell rig was used to remove the material. Some water which was perched on the granite bled into the excavation. To provide a good contact with foundation material, sections of the foundation were dried up and a 76-mm (3-in.) concrete blinding was placed over a compacted sand base. A circular drainage trench was installed around the footing to keep the concrete dry during placement.

The pedestal excavation was carried to a depth of 6.5 m (21 ft). The sides were sloped back 1:1 to prevent caving of the upper portion of the excavation. Small amounts of ground water were encountered. To minimize the flow of adjacent perched water into the excavation, a 152-mm (6-in.) perforated plastic drain was installed on the perimeter of the foundation. This drain terminated in a sump which was continually pumped until the foundation concrete was placed. In order to ensure solid contact between the concrete foundation and decomposed granite base, a 76-mm (3-in.) concrete blind of relatively dry concrete was placed under the entire footing. The granite was scraped clean and dry prior to the concrete blind placement. Backfill was placed around the instrument tower with a clamshell bucket. Compaction was accomplished with hand tampers until enough space was available in the upper levels of the excavation to use a small roller compactor. Backfill around the exterior of the pedestal was placed with a D-8 bulldozer and spread with a grader. Heavy vibrating roller-type equipment was used when space permitted.

Because of the high clay content of some of the upper excavated material, Collins Radio Co. chose to import a large portion of the backfill. The borrow pit consisted of decomposed granite and was located about 13 km (8 miles) from the site. This granite material compacted so efficiently that it was cheaper than trying to obtain the specified 95% compaction with material of high clay content.

2. Concrete Design and Batching

Work started in December, 1969, on testing of aggregates and preparation of design mixes. This work was conducted jointly by Kennard-Hill Consulting Engineers, the Snowy Mountain Authority, and the Ready Mix Concrete staff. Aggregate from the quarry owned by Ready Mix was rejected as being too high in sulfides. The aggregates finally approved were Mugga Porphyry from the Department of Works quarry and Murrumbidgee River coarse sand and Lakelands fine sand. Cement SAA A-2 Type C, low heat cement was accepted as being equivalent to the U.S. Type II. The Mugga Porphyry aggregate proved to be quite sharp and angular, which made it more difficult to obtain a workable mix. The same sands were also approved for the dry-pack grout used for placement under the hydrostatic bearing runner azimuth radial bearing, and azimuth bullgear. The Ready Mix firm erected a plant on-site, as dry deliveries from Canberra could not furnish suitable control. The plant consisted of the following:

- (1) 104-Gg (120-ton) six-compartment overhead bins
- (2) Feeder hopper and elevating conveyor

- (3) 2.3-m³ (3-yd³) aggregate weigh hopper
- (4) 2.3-m³ (3-yd³) cement hopper
- (5) 36-Gg (40-ton) cement hopper
- (6) Automatic reset water meter

The plant had a capacity of 23 m³ (30 yd³) per hour. Approximately 450 Gg (500 tons) of aggregates were stockpiled on-site. Three Fowler Rex 4.6 m³ (6 yd³) transit mixers were on-site for each pour. Two mixers had the capacity of handling the batch plant output and one was on standby.

Ice was required on two pours during the summer months to keep the mix cool. In the winter the water was heated. The average rate of placement of a major pour was 19 m³ (25 yd³) per hour.

3. Concrete Placement

The pour on the instrument tower footing was interrupted by a local cloudburst. The pour was stopped and the cold joint had to be properly cleaned up. The pour was completed 3 days later. The remainder of the instrument tower concrete placement proceeded smoothly.

The pedestal footing and concrete wall placement went smoothly except for the pour immediately below the haunch. During this operation the ambient temperature dropped to -3°C (26°F) about midnight, causing the moisture in the air hoses leading to the concrete vibrators to freeze, and the vibrators became inoperative. A large fire was built on the site and the vibrators were heated. Since there were ample spare vibrators on hand, the placement was able to continue by alternating the warm vibrators. Some defective concrete in a narrow zone in the wall was removed and replaced.

The haunch and roof deck concrete placements proceeded without trouble. The close spacing of the reinforcing in the roof deck immediately adjacent to the collar required that the concrete mix be altered to employ a smaller aggregate. The normal concrete mix with the larger aggregate was used as soon as this area was covered.

The supply air to the concrete vibrators was upgraded using largely fixed piping so that no further problems were encountered during freezing conditions.

4. Concrete - Antenna Structural Interfaces

The azimuth radial bearing was grouted by hand tamping in one night's effort. The grout was core-tested after 3 days and proved to be approximately twice the required strength. Final measurements after grouting indicated that the runner was well within tolerance, and the grouting had not significantly altered the alignment.

Difficulty was experienced in the final setting of the anchor bolts for the azimuth bull gear sole plates. While these bolts were properly set using a theodolite and tape prior to the concrete placement, some shift occurred during placement. This shift may have been caused by the use of pressed fiberboard templates that changed in dimension when wet. Collins Radio Co. was given permission to enlarge about 20% of the

sole plate holes by means of a power-driven cutting tool. The setting of the bull gear grouting proceeded smoothly.

The hydrostatic bearing runner was leveled to specification and properly grouted. Preliminary leveling was accomplished by the pintle radial tool. The final leveling of the runner was accomplished by Talyvel levels. Collins Radio Co. developed the use of air-operated hammers to accomplish the dry packing of the grout. This proved to be very successful, and the runner was grouted in 4 nights. (Daytime grouting was not permitted due to ambient temperature variations.) An oil film height of approximately 0.03 cm (0.012 in.) was maintained through full rotation, which proved the efficiency of the leveling and grouting work. The specification required an oil film height of at least 0.013 cm (0.005 in.).

5. Alidade Structure

Erection of the alidade structure revealed some fit-up problems at the connections just below the elevation bearing platform. This connection was finally made by loosening the bolts at the corner weldments and rotating the weldment to make the necessary adjustment. Field shimming was specified at the joints in the base triangle to overcome the warpage of the end plates. There was difficulty in connecting the elevation bearing tangential links. The flange welds were chipped out and replaced.

All bolts on the alidade structure were tightened by the calibrated turn-of-the-nut method, since no consistency could be obtained with calibrated air-operated wrenches.

6. Tipping Assembly

Erection of the tipping assembly proceeded on schedule. Bolt torquing techniques had been worked out on the alidade, and little difficulty was encountered in this area.

The welding on the elevation wheel splice was accomplished without difficulty. The connection of the rectangular girder to the elevation wheels caused a problem in the fitup. The elevation wheel was 2.22 cm (7/8 in.) too low, not permitting bolts to enter. This joint was redesigned for equivalent strength using welds.

The connection of the center hub to the tie-truss was reinforced by additional splice plates since magnaflux revealed a crack in one of the connecting clips.

In erecting the inner ribs and cantilever ribs, some difficulty was experienced in obtaining horizontal alignment. To overcome some of this lack of alignment, some of the holes in the panel clips were enlarged.

The connection of the cantilever ribs to the inner ribs was both bolted and welded, since ribbed bearing bolts were not used.

It was determined after the reflector backup structural steel was erected that approximately 1200 joints were short of shop weld on some clips. These welds were completed on the structure. This welding effort took about 4 weeks, and no panel alignment was permitted during this period.

The quadripod was erected in 2 days. The apex and two quadripod legs were assembled and lifted as one unit on to the dish in the stow position by the guyed derrick. This assembly was then held

in place by a horizontal line tied to the mast of the derrick and controlled by the 70-ton crane on the ground. The remaining two legs were lifted in place by the guyed derrick, and the horizontal tie-line was let off to accomplish the connections.

Erection of the panels proceeded smoothly. Final alignment was well within specification: 0.0355 cm (0.014 in.) rms versus 0.05 cm (0.020 in.) rms allowable at 45 deg dish attitude.

7. Instrument Tower Windshield

The fabricated instrument tower and windshield elements did not assemble into true circular sections. This factor, combined with a buildup of tolerances on instrument tower/windshield centering, caused the instrument tower insulation to contact the windshield. Adequate clearance was eventually obtained by use of struts inside the instrument tower and the reduction of the insulation from 7.6 to 5 cm (3 to 2 in.). Permanent measuring ports are installed through the windshield so that operating clearances can be verified at any time.

8. Pedestal and Alidade Building Interior

Installation of the electrical-mechanical equipments, air conditioning, cable trays, and fire protection proceeded over a long period of time. Many interferences had to be overcome because of changed models or the use of larger equipment. These problems were generally solved by field sketches prepared by CRC and approved by JPL. The revisions were incorporated on the as-built drawings.

9. Final Acceptance Tests

The antenna servo as implemented during the final acceptance tests consisted of three feedback control loops, a current loop, a rate loop, and a manual position loop. The testing process started with frequency response tests of the closed circuit loop on each axis. The specification on the current loop was a bandwidth (defined as the frequency at which the response phase lag reaches 90 deg) greater than 150 Hz and less than 6 dB of peaking. The azimuth axis bandwidth is 1100 Hz and the peaking is 4.5 dB; and for the elevation axis, the bandwidth is 1100 Hz and the peaking is 4.2 dB.

Open rate loop tests were run to determine the frequency location of various resonances: hydraulic, natural structural, and other structural. Some of these resonances are tabulated below:

	<u>Azimuth</u>	<u>Elevation</u>
Hydraulic	1.1 Hz	1.2 Hz
Natural (1st) structural notch	1.5 Hz	2.1 Hz
Second structural notch	2.5 Hz	4.0 Hz
Third structural notch	3.0 Hz	8.0 Hz
Resonance	20.0 Hz	40.0 Hz

From these tests, a compensation network was developed to close the loop with bandwidth to 5 Hz, minimal phase shift at the position loop bandwidth frequency, and maximal attenuation of peaking responses above 5 Hz.

The closed rate loop was run under two conditions: a steady-state rate of 0.05 deg/sec applied to the antenna and a zero steady-state rate condition. The specification on the rate loop

is a nominal bandwidth of 5 Hz. The following responses were achieved:

	<u>Zero rate</u>	0.05 deg/rate
Azimuth	5 Hz	5 Hz
Elevation	4.7 Hz	5 Hz

The manual position loop, which corresponds to the closed loop used during normal spacecraft tracking, has two bandwidths available and was tested in both modes. The specifications value is 0.2 Hz for the high bandwidth mode and 0.02 Hz for the low bandwidth mode. Bandwidths obtained were as follows:

	<u>High bandwidth</u>	<u>Low bandwidth</u>
Azimuth	0.20 Hz	0.0135 Hz
Elevation	0.205 Hz	0.019 Hz

A further test was made to verify position loop stability under simulated conditions of wear, aging, and signal degradation by varying the position loop gain by +3 and -3 dB increments. Step responses under these conditions showed that control system stability was maintained.

Other tests of significance to antenna tracking performance are the tracking error with the antenna moving at a rate of 0.0015 deg/sec, which corresponds approximately to a sidereal rate; the pointing jitter under a static position command; and the minimum velocity the antenna is capable of maintaining. These results are tabulated below:

	<u>Tracking Error</u>	<u>Azimuth</u>	<u>Elevation</u>
Max pk-pk		0.00082 deg	0.00101 deg
Average		0.00006 deg	0.00005 deg
Pointing jitter		±0.00012 deg	±0.00032 deg
Minimum velocity		0.0002 deg/s	0.0005 deg/s

Other tests also performed were: full speed (0.05 deg/s) tests through complete travel range; verification of the two sets of electrical travel limit switches as well as the "dead man" emergency hydraulic limit valves; tests on the control logic circuits involved in turning on (and off) the antenna hydrostatic bearing hydraulic systems. These tests were performed to ensure satisfactory operation and fail-safe shutdown characteristics.

In summary, the antenna servo and associated controls were installed, tested, and found to be achieving satisfactory specification performance.

E. SCHEDULE

The job kick-off meeting was held on-site Nov. 3, 1969, and site mobilization was started immediately thereafter. The first concrete was poured in the instrument tower footing on Jan. 4, 1970. The pedestal was complete and ready for the installation of the azimuth runner on Oct. 3, 1970. The hydrostatic bearing runner was grouted Feb. 22, 1971, and first elevation rotation occurred on Jan. 28, 1972. The project was essentially completed on July 14, 1972, which was the last time a daily log was prepared. The site project manager departed on that day. The complete schedule of the project is shown in Fig. 20.

Two major factors affected the antenna construction, the first being the late shipment of the

hydrostatic bearing sole plates. This was a delay of approximately 5 weeks. The site manager attempted to have the plates manufactured locally, but this would not have saved any schedule time. The second major delay was caused by the omission of certain shop welds on the primary reflector structure. These welds had to be placed in the air. Final surface panel alignment was not permitted until these welds were completed. This was a delay of approximately one month.

There were minor delays throughout the duration of the project due to weather, short strikes, and other factors. These delays could be considered normal for any project.

F. MANPOWER

All manpower, except for the Collins Radio Co. Project Manager and certain CRC engineering specialists, was obtained from the local Australian labor market. Little trouble was encountered in getting skilled men for the various disciplines, and productivity was generally high.

The following chart (Fig. 21) indicates the average manpower loading for each month of the project, including Collins Radio Co. people. This manpower loading would indicate a larger work force than was employed at Goldstone DSCC for construction of the 64-m antenna. This may be partly explained by the fact that the Australian ironworker received 165 U.S. dollars per 60-hour week, while his U.S. counterpart working the same hours would earn \$1074. Because of this cost differential it is believed the Collins Radio Co. had a policy of over-manning in order to meet or better the schedule objectives with the consequent tradeoff of lower overhead costs inherent in a shorter construction period. All workers on the job were union members. Although there were several threats of strikes on a national and Australian Capital Territory level, most of the strikes never materialized. Those that occurred lasted for only 1 or 2 days.

G. MATERIALS

CRC was directed to use certain Australian materials as part of an agreement between JPL and the Australian Department of Supply. These materials included sewer piping, cement, aggregate, brick, roof decking and siding, lumber, wallboard, metal studs, doors and frames, tile, plumbing fixtures and piping, electrical conduit, and wire. In addition, Collins Radio Co. purchased other Australian materials for reasons of price and schedule. Substitution of Australian materials was approved on-site, and their use produced a quality of construction comparable to the U.S. in all respects.

Major antenna elements other than the A&E work were all fabricated in the United States.

H. SAFETY

1. Accident Record

The final safety report prepared by Collins Radio Co. indicated 115 accidents, but only two lost-time accidents. The frequency rate (as defined by the American National Standards Institute ANSI Z16.1 document) is 10, but this figure can be as high as 15. The severity rate was 410. An index of 5 times that figure is

acceptable. These figures indicate Collins Radio Co. had an excellent safety record. The lost-time accidents reported by CRC may have been reduced to some degree by returning men to work somewhat more quickly than would be the practice in the U.S.

2. Organization and Inspections

Collins Radio Co. passed on the contractual safety requirements on each of their subcontractors. Weekly safety meetings were held on-site to furnish safety instruction. The Australian government, through the Bureau of Hoists and Scaffolds, made a weekly inspection of the site. In one instance they delayed a concrete placement because they felt the iced scaffolding was too slippery.

3. Special Safety Precautions

Safety nets were attached to the rib trusses. However, these nets were shipped to Spain after the erection of the dish structure, and the welding which came later was done without nets. To overcome this hazard, the men were tied to the structure and worked in safety harnesses. This technique was acceptable to the government inspectors.

CRC constructed good access platforms with adequate guard rails for all concrete placements.

Fire extinguishers and water barrels were placed on the alidade roof. No fires of any consequence occurred.

I. JPL SITE ORGANIZATION AND RESPONSIBILITIES

1. Staff, Facilities, and Responsibilities

The JPL resident staff consisted of the resident engineer, the alignment engineer, and the Quality Assurance engineer. The alignment engineer also acted as the assistant resident engineer. The resident JPL staff was assisted by JPL cognizant engineers who were on-site during installation of their specialities, which included concrete structure, hydrostatic bearing installation, electrical, servo hydraulics, and gears and drives. A secretary was hired locally for a portion of the project, and station clerical help was utilized whenever necessary.

In addition to the JPL engineering team, the station assigned five of its staff to assist JPL during the last year of construction and acceptance testing. This arrangement had a twofold advantage, since it greatly assisted JPL and also gave the future operating staff a first-hand knowledge of the antenna.

The resident staff was housed in the station subsistence building and occupied 46.5 m² (500 ft²) of office space. This office provided a good view of the construction and was located about 91.4 m (100 yd) from the construction area. A separate shop area of 18.6 m² (200 ft²) was provided by the station for the JPL alignment tooling and for the granite slab used to zero-set the optical and mechanical tooling.

The resident staff was responsible for the on-site administration of the Collins Radio Co. contract to the extent indicated in the contract. He was required to:

- (1) Establish scientific and technical liaison and give technical approvals and disapprovals.

- (2) Provide such technical direction as is required in the contract.
- (3) Establish Quality Assurance procedures and give approvals and disapprovals in this area.

Within the project, the staff responsibilities included periodic reporting of the job progress to the JPL Project Office, liaison with the JPL DSN representative and the station director, witnessing and verifying all tests, alignments, and inspections performed by the contractor or subcontractors, and maintaining all documentation on file to verify the quality of the antenna for acceptance.

2. Station Support

The station director and his staff were most helpful in providing all types of support. The facilities and the time of the station personnel were always willingly extended to support the project effort. Cafeteria, documentation, photo-

graphic, machine shop, shipping and receiving, and many other services were furnished throughout the project.

3. Network Support Facility

The services of the Network Support Facility, including engineering and drafting support, consultation and advice, materials, and equipment, were all furnished to the resident staff in a most cooperative manner.

4. Department of Works

The Department of Works furnished important support in the areas of consultation and inspection and were always most helpful.

5. NASA/JPL DSN Resident Office Support

The management support of NASA/JPL DSN resident office was a key factor in this project.

VIII. SPAIN SITE CONSTRUCTION HISTORY

A. INTRODUCTION

The construction of the 64-m antenna in Spain was formally begun on June 18, 1970 with a site meeting between the contractor (Collins Radio Co.) and NASA, Instituto Nacional de Technica Aeroespacial (INTA), and JPL representatives. The construction began slowly due to adverse foundation excavation conditions. The erection phases overcame this delay, meeting the major project milestones of azimuth rotations on Feb. 5, 1972 and elevation rotation on Sept. 27, 1972. The antenna was accepted from the contractor on Jan. 2, 1973.

The construction site is located within the existing 26-m station area near Robledo de Chavela. The Robledo complex can be reached by good paved roads. It is located approximately 60 km (37 miles) from Madrid (Fig. 22). The Robledo complex lies in a gently sloping valley characterized by gently and steeply sloped hills with granite outcrops predominating. The areas adjacent to the complex are owned by the Robledo de Chavela township and are utilized principally for grazing. The area is sparsely populated.

The contractor subcontracted for all construction labor and equipment and services from established companies in Europe. The Collins Radio Co. site organization was complex and underwent some changes during the construction period. The intermingling of subcontractor responsibility and Collins Radio Co. direct supervision of laborers further complicated the organizational picture.

The indigenous labor force was well qualified to perform all construction tasks and adapted easily to American tools, products, and installation methods. The language barrier complicated otherwise routine tasks. Critical tasks were conducted by all Spanish crews or all American crews to prevent accidents due to poor communications.

Many American specification materials are also produced in Europe and provided cost savings

to the contractor. Incompatibility of the American measurement system and the metric system caused some difficulties when replacement parts for American equipment could not be purchased near the job site.

The contractor and his subcontractors maintained an excellent safety record. Only one serious injury accident occurred in more than 50,000 man-days worked.

B. CONTRACTOR SITE ORGANIZATION

1. Organization in Residence

The Collins Radio Co. contract was administered in Spain through Collins Radio Constructors, Inc., a subsidiary company incorporated specifically to do business in Spain. The site manager and general superintendent were the only employees of Collins Radio Constructors. The contract negotiator for all contracts and purchase orders let by Collins Radio Constructors was employed by Collins Radio International based in London, England. All site engineers and visiting management and engineers were employees of Collins Radio Co., Dallas.

The resident organization was responsible for performance under the contract and interaction with the JPL resident staff. Labor on specialized equipment and performance testing was done by the site engineers.

2. Subcontractor Structure

All general and construction labor was obtained from subcontractors. The subcontracted labor can be separated into three categories: minor services; construction labor, Collins Radio Co. supervised and contractor supervised; and construction and installation labor for tasks subcontracted to the JPL specification.

a. Laing Iberica, S.A. Laing Iberica contracted to perform all the A&E work to the JPL specification. Their work included all excavation, concrete construction, and electrical and mech-

anical installation. INTEC, S.A., was retained by Laing Iberica to do all electrical and mechanical work. Laing Iberica also provided hourly labor for Collins Radio Co. direct supervision (e.g., secretary, warehouseman, labor to off-load trucks).

Laing Iberica bid the work at the suggestion of the parent company, John Laing - an English Company. The contract value was small in comparison to other work being done by Laing Iberica in Spain, tending to be lost in their over-all efforts. After completion of the concrete work, Laing Iberica negotiated a settlement with Collins Radio Co. to close out the contract.

b. INTEC, S.A. INTEC became the direct mechanical and electrical subcontractor to Collins Radio Co. after the close-out of the Laing Iberica contract. INTEC also provided hourly labor for Collins direct supervision to complete tasks that were not in the INTEC scope of work (e.g., secretary, warehouseman, site cleanup). INTEC also became the successful bidder for the Robledo Station facilities work administered by the Officer in Charge of Construction of the Madrid office of the Naval Facilities Engineering Command. The two contracts suffered schedule delays due to concentration of effort on only one contract at a time. Increased levels of manpower were difficult to obtain.

c. IBEMO, S.A. IBEMO contracted to provide erection labor and equipment during erection of the guyed derrick and the antenna. Millwrights and pipefitters were provided for mechanical assembly. IBEMO provided hand tools, welding machines, a 45-ton crawler crane, and a 2-ton truck.

d. MAPOR, S.A. MAPOR was the customs clearance agent representing Collins Radio Constructors. The agent processed all papers at the port of entry and arranged for transportation of the antenna material to the construction site. In the case of wide or special loads, MAPOR obtained the necessary road permits. Exportation was also handled by MAPOR.

e. Soils Testing, S.A. Soils Testing was retained by Collins Radio Constructors as the independent testing laboratory required under the contract. Under the direction of Dr. Lopex Ruiz, the company was responsible for locating acceptable aggregate sources and the design of the concrete mix. During the concrete placements, Soils Testing provided technicians to monitor and record all batching, perform slump tests, and make concrete test cylinders. After proper cure, the cylinders were tested and Soils Testing issued a report on the tests.

Dr. Lopez Ruiz conducted the trial mixes to determine the proportions of the dry-pack grout. Soils Testing provided a laboratory mixer and scale to batch the grout constituents, technicians to monitor the batching and make test cylinders. After proper cure, the cylinders were tested and a report of test results issued.

f. M.A.N. (Mannheim-Ausburg-Nuremberg). The guyed derrick was rented by Collins Radio Constructors from M.A.N. of Germany. The derrick was the same used by M.A.N. to erect the 100-m Efelsberg antenna near Bonn. The derrick was shipped partially assembled. M.A.N. provided technical supervision during erection, relocation, and disassembly.

Collins Radio Constructors erected the derrick using IBEMO laborers.

g. Robertson, S.A. The metal siding and roof decking for the alidade was installed by Robertson. Their scope was expanded to include the insulation and aluminum cover on the instrument tower wind screen and placement of the alidade building roof.

h. Tomas Bueno, S.A. Tomas Bueno was subcontracted to do all the structural and interior architectural painting. All necessary painting equipment was provided through the subcontract.

i. Consultas Tecnicas. The Collins Radio Constructors bilingual office manager, purchasing agent, and translator were provided through Consultas Tecnicas.

C. INTERFACES

1. Spanish and Local Government, Governmental Agencies.

Collins Radio Constructors dealt with the government and governmental agencies on their own behalf. In the instance of importation, NASA/JPL assisted the flow of importation forms through the customs offices in Madrid. At the port MAPOR, acting as the Collins Radio Co. agent, cleared all items through customs.

2. INTA

INTA is the NASA counterpart in Spain. INTA provided such services as introductions to companies and intervention in customs clearances to minimize delays on schedule-critical items.

3. JPL and the Station

The JPL resident staff provided the liaison between Collins Radio Constructors and JPL; the station; and in most instances, with INTA. The station graciously provided many services to the contractor, such as backup telephone service, sanitary services connection, potable water, limited use of the cafeteria, minor equipment load and mail courier from Madrid. The use of these services contributed greatly to the ease with which day-to-day operations were conducted.

D. SITE CONDITIONS AND CONTRACTOR PHYSICAL PLANT

1. Construction Area and Interferences

The construction area was situated within the Robledo Complex area adjacent to the Colmenar del Arroyo road and the complex access road. The construction site was very small. An agreement was reached in the first site meeting to allow the contractor to use an additional small area between the complex access road and the complex boundary. Additional NASA/INTA property outside the complex fence was used for storage. The construction water reservoir was constructed on NASA/INTA property outside the complex fence.

The contractor relocated the complex guard-house and constructed temporary security fencing between the construction area and the complex to permit the contractor employees and deliveries uncontrolled access to the construction area. Station personnel and visitors were allowed free passage through the construction area.

Access to lands adjacent to the complex and permission to place the guyed derrick anchors

were negotiated with the township of Robledo de Chavela. This agreement also included the necessary easements to extend commercial power to the construction site. At the completion of construction, the guyed derrick anchors were covered with earth. The power poles were left in place.

Construction of the tunnel extension from the Collins Radio Co. contract portion to the control room caused interference with the antenna construction. The tunnel was founded in granite and blasting was necessary to loosen the material for excavation. Work stoppages to watch the explosions were common; and in some instances, parts of the Collins Radio Co. work area had to be vacated for safety reasons.

The small construction area necessitated utilization of areas adjacent to the complex access road. The complex traffic made working adjacent to the road hazardous and hindered safe movement of the workers between the construction areas on either side of the road. The access road was used for locating the mobile crane and for unloading trucks. This caused congestion of traffic to the complex and interfered with construction operations utilizing the road and adjacent area.

2. Offices, Warehouses, and Utilities

The construction offices were located in close proximity to the antenna and in good view of all construction activities. MAPOR provided Collins Radio Co. an office in Madrid and processed all incoming and outgoing teletypes for Collins. MAPOR leased a warehouse for Collins Radio Co. near Madrid to provide covered storage of parts and equipment received well in advance of their needed date.

The Collins Radio Co. office consisted of a prefabricated building divided into two-man offices. This building housed the resident staff, secretary, plan room, photo copier, and sanitary facilities. A prefabricated warehouse was constructed that housed all small electrical and mechanical parts and tools.

Laing constructed a stucco office building and warehouse from common Spanish clay tile. After the completion of the Laing work, Collins Radio Co. took over these buildings for additional material storage, red-lined drawing storage and offices for IBEMO. Laing also constructed a worker's changehouse that was torn down after completion of the concrete work.

IBEMO assembled a sectionalized metal building as a worker's change room and for tool storage.

INTEC maintained their offices near the site facilities work area administered by the OICC. A simple changehouse was provided for the workers near the Collins Radio Co. work area.

The construction site was powered by portable generators during the concrete work. The increased power required to operate the guyed derrick was supplied by a commercial line through a 350-kVA 50-Hz 220 V/380 V transformer on-site. The power line, breakers and transformer were provided by Collins. The two 350-kVA 60-Hz 480-V engine generators used in Australia were shipped to Spain to operate the antenna during rotations and testing.

Through negotiation with the station, Collins Radio Co. provided 50-Hz power to the JPL offices for heating in return for 60-Hz, 120-V power for

the Collins Radio Co. office equipment, potable water and connection to the sanitary sewer.

Collins contracted with CTNE (Compania Telefonica Nacional de Espana) for a telephone through the El Escorial exchange. NASCOM was instrumental in obtaining the utilizing the NASCOM cable to El Escorial.

3. Importation and Transportation

All sea freight was imported by the Collins Radio Constructors customs clearance agent, MAPOR. Two ports were used. Barcelona, the major port, was modern and well equipped to handle all the antenna structural elements. Bilbao, in north Spain, was used to receive cement shipments from England, paint from Holland, and the guyed derrick from Germany.

Air freight was used for small parts, documentation, and repair parts not available in Spain. The importation of these items was handled through the NASA/INTA agent in Madrid.

The importation, exportation, and accountability of all material was very important, since all imports were duty free. Importation forms were prepared by the contractor and countersigned by the JPL resident. NASA/INTA approved the importation before the forms were sent to the customs authorities. After the material was installed on the antenna, a cancelation form was prepared by the contractor to show disposition of the imported items. Exportation forms followed the same preparation and approval procedure as the importation forms.

Transportation of oversized and heavy loads was provided through MAPOR. Very large, sophisticated hauling equipment that is able to negotiate narrow, winding local roads is available in Spain. Long distance hauling does not pose a problem, since Spain is developing a modern highway system throughout the country. Road permits were obtained from the Spanish government by MAPOR.

Generally speaking, all arriving shipments were adequately packaged. Large, odd-shaped pieces were difficult to handle and suffered some damage. Some containers were inadequate, and interior damage was sustained. Packing was not adequate to withstand outside storage, and the contents showed evidence of corrosion.

Receiving inspection was for visual damage, stateside inspection documentation, and shipping documentation per the Collins field quality control manual. When damage was noted, a field damage report was generated and corrective action was initiated by engineering. If corrected hardware still deviated from the drawings and specification, Material Review Board action was initiated. Stateside inspection documentation was reviewed for discrepancies whose repair had been deferred to the field (VDMAR). When these repairs were completed, the VDMAR was closed out.

4. Heavy Equipment

Collins rented the heavy equipment they needed from contractors in the Madrid area or through one of their subcontractors. IBEMO provided a 45-T Link-Belt crawler crane on a rental basis. Laing Iberica S.A. rented 50-ton cranes for the concrete placements from Gil, S.A. a heavy equipment firm in Madrid. Trucks, excavators, and loaders were rented from small firms in the local area.

5. Batch Plant

The batch plant was purchased as a new unit by Laing Iberica specifically for the antenna construction. The unit was a German designed and manufactured Stetter semimobile batching unit distributed in Spain by Maquinas y Materiales para Obras, S. A. The unit incorporates a bank of five radial aggregate bins that gravity feed into a scale hopper. Laing installed two cement silos with tandem screws feeding the automatic cement scale. The batching unit utilized a flow-metering device to batch the mixing water, but its tolerance was too broad to maintain the low-slump concrete required by the specification. The automatic water-metering device was replaced by a direct reading volumetric measurement tank. The batch plant was capable of 50 cycles per hour or a production rate of 37.5 m^3 (50 yd^3) of concrete per hour.

6. Guyed Derrick

The guyed derrick, rented from M.A.N. of Germany, stood 106 m (350 ft) high. The boom had a capacity of 80 metric tons (88 tons) at 40 m (132 ft). The mast was supported and held stable by a ball-socket joint at the base and a six-guy masthead at the top. No intermediated guys were necessary. The entire mast-boom assembly rotated a full 360 deg under the guys. The guys were placed at a 60-deg vertical plane angle to the mast.

The derrick was shipped in partially assembled, 6-m (20 ft) long sections which were assembled into mast sections on the ground. The first section containing the ball-joint and sections two and three were hoisted into place using the 45-ton crane. Subsequent sections were hoisted into place using a hammerhead mounted on the uppermost mast section. The guys were hoisted with the hammerhead and tensioned by a winch mounted on each of the guy anchors. The boom was hoisted by sheaves and cables integral to the derrick design.

The load radius of the guyed derrick did not allow the elevation bearing castings to be placed from a derrick location outside of the reflector radius. After the majority of the reflector structure was assembled, the entire derrick was moved on a radial line 20 m (66 ft) farther from the antenna outside of the reflector radius. This capability was a part of the derrick design. Beams were placed on a prepared bed, greased, and the derrick baseplate containing the ball-joint was pulled incrementally to the new location. As the base was moved, the guys were adjusted to keep the mast vertical. From this second location the remaining portion of the reflector was assembled.

E. CONSTRUCTION, CONSTRUCTION TECHNIQUES, AND PROBLEMS

1. Site Grading and Structural Excavation

Site grading began soon after the formal site meeting starting construction. A single 955 Caterpillar front-end loader was used to remove the overburden, which was stockpiled for use as backfill material. The waste excavation was used to fill low areas around the station complex. Firm granite was encountered above the site elevation as well as in the pedestal and instrument tower excavations. The granite was not fractured and decomposed and was too hard to be excavated

by the 955 loader with a ripper attached. Laing engaged the services of Cavosa, S. A., a noted blasting firm from Madrid. Blasting was employed to fracture and loosen the granite which was then excavated by hand. Laing chose this method of excavation for economic reasons. However, significant schedule gains could have been achieved if Collins had constrained Laing to use heavy machine excavation techniques.

2. Concrete Design and Placement

During the excavation of the pedestal, Soils Testing, under the direction of Dr. Lopez Ruiz, conducted source inspections of several aggregates and prepared a report of acceptable sources. Crushed limestone from the Pedraza Brothers in Robledo de Chavela and washed river gravel and sand from El Campillo near Arganda were selected by Laing as the most economical. Soils Testing designed the pedestal concrete mix proportions using the selected aggregates and Type II Portland cement from Blue Circle in England.

The cement, aggregate, and water were batched by the on-site plant. Each transit mix truck was charged with six batches of 0.75 m^3 (1 yd^3) or a total charge of 4.5 m^3 (6 yd^3) of concrete. Mixing was done in the transit mix trucks. After batching, the truck was driven to a standby area during the mixing time of 10 min. The concrete temperature and the slump were taken before the truck was released to the placement area.

The concrete was discharged into special 1-m^3 buckets. Laing rented two 50-ton cranes to swing the buckets over the placement point. Some parts of the footing were placed directly from the transit mix trucks. All concrete was vibrated in place with 7.6-cm (3-in.) Wacker electric vibrators.

The Laing design buckets proved to be unsatisfactory with the low slump concrete being placed. The stiff concrete stayed in the bucket and had to be vibrated to flow through the hopper. Air vibrators were added to the buckets, but they froze up in cold weather.

The placement rate, which was dependent upon batching, mixing, discharge, and placement, was 15 m^3 (20 yd^3) per hour. The maximum rate achieved was 20 m^3 (27 yd^3) per hour. The average rate of placement for each lift, affected by downtime for broken equipment and faulty batches, was much lower, ranging between 8 and 13 m^3 (11 and 17 yd^3) per hour. The overall average for 1800 m^3 (2400 yd^3) of placed concrete was 9 m^3 (12 yd^3) per hour.

The specification required the contractor to control rigidly the slump and temperature of the concrete being placed. All pedestal concrete was placed between November 1970, and May 1971. The nighttime temperatures during this period were as low as -7°C (20°F). To meet the specification, the contractor had to install a boiler to heat the concrete mixing water, which provided the necessary heat to the batch to satisfy the specification.

The batch plant scale accuracy did not fall within the specification requirements and had to be calibrated before each use. The automatic water-metering device was replaced by a direct reading volumetric measurement tank. Many other minor problems were experienced, all due to the close tolerances on the concrete required by the specification.

The limestone from the Pedraza quarry required continuous inspection to guard against a predominance of elongated and flat stones. The crusher jaw openings and the screen sizes underwent several adjustments to obtain the correct aggregate sizes and gradation. Before the necessary quantity of aggregate for the entire project had been crushed and stockpiled, the vein of sound, unweathered limestone deteriorated and the quarry was closed. Laing, in conjunction with Soils Testing, substituted crushed limestone from the Ferreras Cuenca quarry, southeast of Madrid.

3. Concrete—Antenna Structural Interfaces

The placement and alignment of the radial bearing, azimuth bullgear sole plates, and the hydrostatic bearing runner segments were completed in October 1971. The installation went smoothly, using ironworkers from IBEMO and Collins alignments personnel.

The runner segments were preserved with cosmoline and a crepe texture protective paper inside of the wooden shipping containers. The containers were stored on-site and were subject to the weather. The weight of the container covers forced the crepe pattern through the cosmoline, allowing rainwater to contact the metal runner surface and cause slight corrosion. The runner performance was not affected by the corrosion. The corrosion could have been prevented by inside storage or use of hermetically sealed packaging.

Soils Testing conducted laboratory and field-trial mixes to determine the proportions of the dry-pack grout to be placed between the pedestal and the antenna structural interfaces. Soils Testing provided a laboratory mixer and calibrated scales for the nights on which the grout was mixed and placed. Organization and supervision of the mixing, testing, quality control, and placement of the dry-pack grout is to the credit of the Collins Radio Constructors resident staff.

4. Alidade Assembly and Instrument Tower

A dock fire in Barcelona nearly caused a major schedule delay. The fire began in a raw rubber shipment stored adjacent to the alidade structural members. A dock worker was solely instrumental in separating the burning bales of rubber and the alidade corner weldments. The intense heat burned the wood cribbing on the corner weldments, but did not cause any damage to the steel itself.

The erection and alignment of the alidade was routine, since trial assembly had been accomplished at the fabricator's shop. Collins elected to use a fixed amount of nut rotation to assure proper bolt torque which simplified quality control of the structure. The rigidly controlled test results were within specification, confirming that torquing had been done properly.

The instrument tower elements did not assemble into true circular sections due to a buildup of fabrication tolerances. The sections were held round by internal radial struts. Unfortunately, the struts were removed after assembly, causing the instrument tower and wind screen to touch as the antenna rotated. This oversight caused expensive rework of the instrument tower in-place to eliminate the instrument tower and wind-screen interference.

5. Pedestal and Alidade Building Interior

Installation of the electrical, mechanical, air conditioning, and fire protection systems was extended over a very long period of the antenna construction. Most of the delay was caused by the failure of the subcontractor to maintain the work flow. Too, there was no contractual requirement to complete these areas for occupancy before the completion of the antenna proper.

6. Reflector Backup Structure

Erection of the main members progressed routinely. The very large field weld in each wheel was accomplished satisfactorily. Each weld was made continuously over a 48-hour period.

A few bolts were found improperly torqued. The contractor undertook a program to recheck all the bolts to verify that adequate torquing had been accomplished. Less than 5% were found to be improperly torqued. It is felt that due to the heavy workload of checking the rib repairs (see paragraph 7), the quality control representative could not keep abreast of the progress of the torquing crews. In subsequent torquing, a full-time quality representative was assigned.

7. Primary Reflector Structure

The inner rib trusses were staged upright near the antenna for cleaning and painting. During the night of May 11, 1972, a wind gust toppled the staged ribs, similar to the domino effect. A second ironworker superintendent was brought from the IBEMO shop to direct the repair work. Traditional blacksmith methods were used to straighten the bent truss members. As soon as the ribs were repaired and painted, they were erected. The hoops were installed and the entire assembly bolted and torqued before the cantilever ribs were erected.

It was discovered that some of the welds on the rib trusses were omitted or incomplete. These welds were completed while the trusses were still on the ground. Each assembly was inspected for welding, cleaning, and painting before it was erected.

The cantilever ribs were preassembled on the ground into groups of three. Safety nets were attached before they were hoisted into place. The antenna was rotated in azimuth to accommodate the reach of the guyed derrick. The ribs were erected loose-bolted, aligned to elevation, and then the bolts were torqued.

The contractor mounted a half-ton crane straddling two rib assemblies to hoist the surface panels to the reflector area. A lifting fixture was built to hold two panels and fixed cables guided the fixture as an elevator. As the panels were installed, the panel attachment clips were moved if found to be in error by more than the built-in adjustment tolerance. Some of the panels did not have the correct panel-to-panel gap and were saw-cut in place to achieve the minimum required gap.

8. Quadripod

The quadripod erection was unique and significantly reduced the risks and time involved in erection. The quadripod apex and the four legs were assembled as a unit on the ground. An X-shaped lifting fixture was constructed that attached to the apex and supported the four legs near mid-span through adjustable cables. The apex and two legs were assembled and supported by the guyed

derrick. Then the remaining legs were attached using the 45-ton crawler crane. The quadripod assembly was erected while the guyed derrick was in the near position but without the jib. The cables supporting the legs were adjusted to give the proper stretchout of the attachment points.

9. Hydrostatic Bearing Runner and Pad Repair

On Nov. 12, 1972, as the antenna was being rotated, a foreign object became caught between the runner and the film height sensor (skateboard). As the antenna motion continued, the foreign object gouged the runner, which in turn precipitated pad damage as the pad moved over the damaged runner area. Damage to both the pad and runner continued until the friction force equaled the antenna rotating force. The major runner damage was confined to a 3-m length of the runner. The rear pad damage was directly related to, and was a mirror image of, the runner damage.

The major damage to the runner was repaired by first removing all loose material. The gouge was filled to above the level of the runner surface with weld material placed as stringer beads, and spacing techniques were used to prevent heat distortion of the runner. After welding, the repair area was ground, filed, and hand-stoned to remove excess weld material. The area was carefully measured to assure that the original runner flatness of 0.07 mm (0.003 in.) was obtained.

The damaged areas on the rear pad were ground out and inspected. The pad was preheated for 12 h at an oven temperature of 480°C (900°F), as checked with temperature-sensitive crayons. Welding rod was placed as stringer passes in the welding process.

As in the runner repair, sufficient weld material was placed to be sure that the repair areas were above the plane of the pad surface. After welding, the pad was returned to the oven and heat treated at 650°C (1200°F) for 20 h. The pad surface was ground in 0.02-mm increments until flat. After grinding, the pad surface was phosphate coated.

After the pad and trough were reassembled, the runner surface was vacuumed and wiped clean with solvent to remove all foreign particles and was visually inspected before bolting down each access cover plate. The hydrostatic bearing oil was filtered before being returned to the oil trough and refiltered in the trough. All the film height recording devices were refurbished with new bearings and recalibrated. The antenna was rotated and returned to testing status on Dec. 5, 1972. The repair was completed in an expeditious manner by the contractor, and operational tests and rotation checks have shown no deterioration in operation parameters.

10. Final Acceptance Tests

The antenna servo final acceptance tests consisted of three feedback control loops, a current loop, a rate loop, and a manual position loop. The testing process started with frequency response tests of the closed current loop on each axis. The specification on the current loop was a bandwidth greater than 150 Hz and less than 6 dB of peaking. The azimuth axis bandwidth is 1100 Hz and the peaking is 4.5 dB; and for the elevation axis, the bandwidth is 1100 Hz and the peaking is 4.2 dB.

Open-rate loop tests were run to determine the frequency location of various resonances:

hydraulic, natural structural, and other structural. Some of these resonances are tabulated below.

	<u>Azimuth</u>	<u>Elevation</u>
Hydraulic	1.1 Hz	1.2 Hz
Natural (1st) structural notch	1.5 Hz	2.1 Hz
Next notch	2.7 Hz	4.5 Hz
Next notch	3.0 Hz	5.5 Hz
Resonance	20.0 Hz	40.0 Hz

From these tests, a compensation network was developed to close the loop with bandwidth to 5 Hz, minimal phase shift at the position loop bandwidth frequency, and maximal attenuation of peaking responses above 5 Hz.

The closed rate loop was run under two conditions: a steady-state rate of 0.05 deg/sec applied to the antenna and a zero steady-state rate condition. The specification on the rate loop is a nominal bandwidth of 5 Hz. The following responses were achieved:

	<u>Zero rate</u>	<u>0.05 deg/sec rate</u>
Azimuth	3.4 Hz	4.4 Hz
Elevation	3.3 Hz	4.2 Hz

The manual position loop, which corresponds to the closed loop used during normal specification tracking, has two bandwidths available and was tested in both modes. The specification value for the high bandwidth mode is 0.2 Hz and is 0.02 Hz for the low bandwidth mode. Bandwidths obtained were as follows:

	<u>High bandwidth</u>	<u>Low bandwidth</u>
Azimuth	0.20 Hz	0.02 Hz
Elevation	0.205 Hz	0.022 Hz

A further test was made to verify position loop stability under simulated conditions of wear, aging, and signal degradation by varying the position loop gain by ± 3 dB increments. Step responses under these conditions showed that control system stability was maintained.

Other tests of significance to antenna tracking performance are the tracking error with the antenna moving at a rate of 0.0015 deg/sec, which corresponds approximately to a sidereal rate; the pointing jitter under a static position command; and the minimum velocity the antenna is capable of maintaining. These results are tabulated below:

<u>Tracking error</u>	<u>Azimuth</u>	<u>Elevation</u>
Max pk-pk	0.00083 deg	0.0015 deg
Average	0.000098 deg	0.00000 deg
Pointing jitter	± 0.00039 deg	± 0.00025 deg
Minimum velocity	0.00039 deg/sec	0.00086 deg/sec

Other tests performed: full speed (0.5 deg/sec) tests through the complete travel range; verification of the two sets of electrical travel limit switches as well as the "dead man" emergency hydraulic limit valves. Tests on the control logic circuits involved in turning on and off the

antenna drive and hydrostatic bearing hydraulic systems were performed to ensure satisfactory operation and fail-safe shutdown characteristics.

11. Demobilization

The antenna was accepted onsite on Jan. 2, 1973 subject to the completion of minor inspection discrepancies. The discrepancies were corrected during the demobilization period.

Demobilization was relatively simple. The prefabricated office buildings and warehouse were dismantled and sold. The tile buildings were demolished and removed. The site was cleaned up and graded to reasonably smooth lines. The tools were crated and exported through MAPOR to Collins, Dallas and Collins International in England.

The commercial power line was removed from the station property. The transformer and switch gear were sold since it was of Spanish origin. The transformer house was the last item to be cleared in early February 1973.

F. SCHEDULE

1. Construction Schedule Chart

Figure 23 shows the major schedule elements for construction. The duration of such items as site work, interiors, electrical and mechanical points out the lack of subcontractor scheduling to complete these items in a timely manner. It can be argued that such scheduling was not critical, since the antenna structural assembly was the pacing item. In spite of delays the antenna was completed within the original contract period of 31 months.

2. Factors Affecting Schedule

a. Language barrier. The inability to speak Spanish with the management and engineering staff members of the Spanish subcontractors was frustrating and caused schedule delays, usually in the form of lack of interest on the part of the subcontractor or the contractor's inability to interpret the specification correctly. Work in several areas of the A&E construction had to be redone to meet American trade standards. Translation of the specifications and the ability to direct the workers in the worker's language would have given the subcontractors and their laborers a better understanding of the critical nature of the work to be performed and would have eliminated much of the rework.

b. Laing Management. In the early weeks of the Laing contract, Laing displayed a low level of management interest because the value of their contract with Collins was low relative to their other contracts in Spain. The Laing resident was inexperienced and could not read the English A&E specification. A bilingual British engineer assisted in the translations between Collins and the Laing resident. However, British customs and construction methods differ, too, adding to the overall lack of communication between Collins and Laing. The Laing management did not understand the importance of their schedule upon the overall Collins/JPL Contract schedule.

3. Construction Contingencies

a. Granite and General excavation. Firm granite, although not totally unexpected, delayed

the completion of the pedestal footing and instrument tower foundation excavation. The work was done by slow hand methods. Laing relied on CA VOSA, S.A., for the dynamite work. This company did not maintain their promised schedules due to commitments elsewhere. With stronger management attention in this area, the construction schedule could have been shortened by up to 3 months.

b. Construction Equipment. Laing and INTEC were continually stopped because of equipment failures. All backfilling was very inefficient due to the tamping machines being inoperative. In most cases the machinery was down so long that rain or ground water infiltrated the placed material making further compaction impossible. The saturated material was removed and placed again.

The batch plant was new equipment and suffered from the usual period of an initial setup and training of the operator. The importance of the tolerances on the concrete was under-estimated. The batch plant was adjusted several times before it was resolved that it would meet specifications only through the use of a nonlinear weight curve. The water meter was replaced by a specially designed volumetric device.

c. Weather. Cold, rainy, and snowy weather during the 5-month period of concrete placement delayed the construction of forms and placement of rebar and embedded items. Work was rarely stopped, but long periods of slowness and inactivity were common. Placement of low slump concrete in the warm temperatures of late spring and summer should be avoided to minimize premature sets of the concrete.

The summer months were warm and dry and provided excellent construction weather. Rain just before the alidade building was closed in caused some inconveniences and extra cleanup work. Considering the project as whole, the weather was not a significant influence.

d. Wind Damage Rib Trusses. The repair of the rib trusses began immediately after the damage occurred. The accident took place before the actual need date, and at no time during the repair was the antenna erection work stopped to wait upon the rib repair. It is not clear that the repair caused a schedule delay, although it can be argued that the additional work utilized men that could have been assigned to progressive antenna construction. The additional work was, at least, demoralizing.

e. Weathered Theodolites. Analysis of the panel alignment data disclosed that the readings were not repeatable. Consideration of all possible error sources lead to the discovery that the alignment theodolite had been left mounted on the antenna and unprotected from the rain. Close inspection of the unit showed moisture in the optical train and in the vernier scales. The panels were realigned and the theodolites cleaned, affecting the schedule by approximately 1 week.

f. Hydrostatic Bearing Repair. The damage to the hydrostatic bearing runner and pad occurred during final acceptance testing with the antenna structural assembly complete. The repair stopped the testing and delayed the final acceptance of the antenna by 3 weeks.

G. MANPOWER AND LOCAL LABOR

1. Manpower Chart

Figure 24 shows the manpower expended over the life of the construction phase. On-site, 53,545 man-days were spent, which includes the American staff members and the indigenous labor force. In general, a 50- to 54-hour week was worked. The chart is presented as the average manpower per month.

2. Skills and Productivity

The indigenous labor force was found to be conscientious and hardworking. The American technology and methods were strange, but in the majority of instances, the American way was adopted. Manual labor and carpentry skills were less accommodating to American directives. No differences existed between American and indigenous ironworkers. Labor unions are nonexistent in Spain. No time was lost to strikes or labor disputes. Inclement weather did not stop the work, except during the steel erection when work was discontinued for safety reasons.

The ironworkers returned to Robledo de Chavela for a hot lunch with their families each day between the hours 1 PM and 2:30 PM. This long lunch was a result of the Spanish custom of the midday meal being the main meal of the day. In non-construction industries, a 3-hour lunch is normal. The remaining work force ate a cold lunch on-site between the hours 1 PM and 2 PM.

3. Lodging and Transportation for Laborers

Most of the workers were obtained from the local villages or from Madrid. These men lived at home with their families. The ironworkers came from Bilbao in Northern Spain. They found apartments for themselves and their families in Robledo de Chavela. American personnel rented apartments in Madrid or El Escorial.

Transportation was provided to the workers. From Madrid the workers were carried by bus or van. A canvas covered truck made runs to the local villages of Navas del Rey and Robledo de Chavela. The ironworkers taken by bus to and from Robledo de Chavela. The American staff used rental cars.

H. EUROPEAN MATERIALS AND SERVICES

1. Cement

Collins purchased the Type II Portland cement from Blue Circle of England. The cement was made to the ASTM standards and met all the test parameters. Type II Portland is a relatively new product to be available on the European market.

2. Rebar, Steels, Welding Rod

Deformed rebar with high tensile strength is available in Spain. Some was used to replace missing quantities in the pedestal. Use of locally available rebar would help to minimize the on-site straightening of sea-freight shipment damage.

Mild steels are available for minor repairs and noncritical structural work. Steels meeting the ASTM designations are not available. Welding rod meeting American specifications is generally available.

3. Paints and Tars

Amercoat paints and thinners were available in Spain in limited supplies. The purchases by

Collins Radio Co. were made in the Netherlands and shipped directly to the site. Other general-purpose oil or latex base paints were available from Spanish and American named firms. Given the generic name, solvents and thinners that are in common usage in the U.S. were available.

Tars and tar products are available in Spain. With a translation of the applicable specification, an equivalent product was found.

4. Lead

The lead ingots for the counterweights were purchased in England. A significant savings of shipping cost was made by European purchase. Temporary, low-purity counterweights were purchased in Spain on a guaranteed buy-back price contract.

5. Competitive Products for Future Construction

Modern Spain has a wide variety of A&E materials that compare equally and competitively with American products. It will be to the advantage of the contractor to purchase local materials on future installations.

To the user's advantage, local materials permit repair and servicing with readily available parts. Examples of available materials are conduit, distribution panels, J-boxes, cast iron pipe, tubing, plumbing fixtures and supplies, doors, windows, and noncritical structural steel shapes.

I. SAFETY

1. Safety Record

The on-site safety record was excellent. The frequency rate of 85.9 as calculated in accordance with the American National Standards Institute publication ANSI Z16.1 on Recording and Measuring Work Injury Experience does not represent a true picture of the safety record. The severity rate of 1725 is within the normal acceptable limits. The low severity rate demonstrates that the incurred injuries were minor in character. The high number of injuries of a minor character is due to the benefits that the laborers received under the Spanish national insurance act which allows the worker full compensation for time lost from even very minor injuries.

2. Organization and Inspections

Collins Radio Co. passed the contractual safety requirements on to each of their subcontractors. The subcontractors instructed their people under their normal safety program. Deficiencies resulting from JPL and Collins Radio Co. conducted safety inspections were passed on to the Collins Radio Co. subcontractors.

JPL gave management support to the inspections in the management meetings with Collins Radio Co. The JPL safety department representative visited and inspected the construction site putting full support behind the safety program.

3. Special Safety Precautions

Blasting posed an extreme hazard in the construction area. The construction of the tunnel extension under a separate contract required blasting while the antenna was being erected. The paging system was used to give an advance warning of the blast and a horn was sounded just before the blast was detonated. In the later stages of con-

struction, the blasting was limited to the lunch hour.

Particular care was taken during the concrete pours to build adequate work platforms and guard rails. The heavy concrete buckets were a hazard and could easily knock a man off the work platform.

During welding, fire watches were stationed to guard against accidental fire. Fire extinguishers and water barrels were placed on the alidade roof. The station fire brigade was available to assist with station fire-fighting equipment and in the off hours.

Safety nets were attached beneath the rib trusses. During erection and torquing, the work area was more than 50 m (165 ft) above ground.

J. JPL SITE ORGANIZATION AND RESPONSIBILITIES

1. Staff, Facilities and Responsibilities

The resident staff was composed of two JPL engineers and one JPL Quality Assurance engineer. The JPL members of the staff were supported full time by three station personnel: an alignments engineer, a Quality Assurance engineer, and a secretary. The resident staff was housed in a prefabricated building divided into offices with all normal services. A second building was attached to contain alignments tooling and the granite slab used to zero-set the optical and mechanical tooling. The office building was located near and in full view of the antenna and construction area.

The resident staff was responsible for the on-site administration of the Collins Radio Co.

contract to the extent indicated in the contract, namely:

- (1) Provide scientific and technical liaison and give technical approvals and disapprovals.
- (2) Provide technical direction to the extent that such direction is provided for or is contemplated by the contract.
- (3) Provide quality assurance liaison and give approvals and disapprovals in the area of Quality Assurance.

Within the project, the staff responsibilities include periodic reporting of the job progress to the JPL Project Office, liaison with the JPL DSN Representative and the Station Director, witness and verification of all tests, alignments, and inspections performed by the contractor or sub-contractors, and maintenance of all documentation on file to verify the quality of the antenna for acceptance.

2. Station Support

The Station Director and his staff were most helpful in providing all types of support. The facilities and the time of the station personnel were graciously extended to support the project effort.

Cafeteria, documentation, photographic, machine shop, and shipping and receiving services were graciously provided during the entire construction period. On several occasions, the availability of these services on-site made the difference between success and failure of a critical phase of the construction or a particular alignment or test. The most significant support was the placement of the new powerhouse into service firmly tied to the antenna when both of the Collins Radio Co. 60-Hz construction power generators failed.

IX. TRICONE FABRICATION AND INSTALLATION

A. INTRODUCTION

Philco-Ford, Palo Alto, Calif., was awarded the contract on Nov. 20, 1970 to fabricate, transport, install, align, and test a tricone and sub-reflector assembly on each of the 64-m antennas at Australia and at Spain. The installation of JPL-provided electronic equipment into both tricones was added to their task by a supplement to their contract.

The major subcontractors for the manufacturing of the above assemblies were:

- (1) Capital Westward, Los Angeles, manufacturer of the tricone support structure, the major structures for the subreflector, and the support equipment such as the feedcone lifting fixtures and hoisting equipment.
- (2) Aeronca, Inc., Torrance, Calif., manufacturer of the panels for the sub-reflector.

B. AUSTRALIAN INSTALLATION

1. Implementation

At the Australian site, Philco-Ford was represented by a site manager, a field crew supervisor, and one microwave engineer. Evans-Deakin of Sydney provided the site labor and some material hardware. Work by Evans-Deakin was under direction of Philco's site manager. Brambles, Ltd. of Sydney was on contract to Philco for customs clearance and inland shipping. JPL was represented by a field engineer whose task was to coordinate the scheduling and service requests between the contractor and the station director. A JPL mechanical engineer was also present who was responsible for the microwave installation into the tricone structure and its testing.

The completion of this contract was dependent on the station's cooperation in providing Philco-Ford with electrical power, antenna movements, use of the station's facilities, a

telephone, and the use of the cafeteria. These services were very generously provided by the station director, and were a contributing factor in completing the project to everyone's satisfaction. This takes into consideration that, in addition to the usual field construction problems, progress was slowed due to winter weather, rain, and high winds.

NASA's fuel and energy conserving action, due to a cutback in funding, limited the availability of antenna movements (the pumps for the hydrostatic bearing's oil were shut down every evening thus requiring a reheating time in the mornings). Through the mutual understanding and cooperation of Philco-Ford with JPL and the station personnel, these problems were overcome and serious delay avoided.

2. Safety

Two accidents occurred: (1) a canvas tent burned during welding but caused no injuries, and (2) one subcontractor employee suffered minor burns when a paint can exploded during burning of trash. Otherwise the safety record was excellent.

3. Schedule

During Philco-Ford's efforts the station was doing work on the antenna such as cabling, coolant lines, transmitter installation, etc., which required very close scheduling, as Philco's contract gave them uninterrupted access to the antenna.

Weekly meetings between Philco-Ford, JPL, and the station personnel were held where problems were solved and a mutual agreed-upon schedule was worked out for the following week. In general, there existed a good relationship between the contractor, JPL, and the station personnel.

C. SPAIN INSTALLATION

1. Implementation

Philco-Ford contracted MAPOR, S. A. of Barcelona as their broker and forwarding agent in

Spain. AMERINTEC of Madrid provided all site labor including a translator. Philco-Ford was represented by the same Program Manager who had been at Australia. An organizational change in Philco-Ford's crew proved to be a substantial improvement over the crew in Australia and proved to be a much smoother and more cooperative implementation effort throughout the contract in Spain.

JPL was represented by the same field engineers who had coordinated the scheduling and service requests between the contractor and the station personnel in Australia, and they performed the same function at the Spain facility.

2. Schedule

Philco-Ford was contractually entitled to the same provisions as in Australia. The station's crane and a forklift were made available, although this created some problems at times when the crane was needed elsewhere on-site. Also, the

station's boom length proved to be too short, forcing Philco-Ford to hire a 45-ton crane. This was not immediately available in the Madrid area, and caused some minor schedule delay and cost increase. In the total effort the use of the site crane and the hard work of all enabled the contract to be completed ahead of schedule in spite of many days lost due to bad weather.

3. Safety

The crew was safety-conscious, and a safety record of no accidents resulted.

4. Language

The Spanish language was a minor problem but did not impact the schedule. In general, Philco-Ford's organization in Spain was a definite improvement in comparison to that in Australia, and a good relationship between the contractor, subcontractors, JPL, and the station personnel existed throughout the contract.

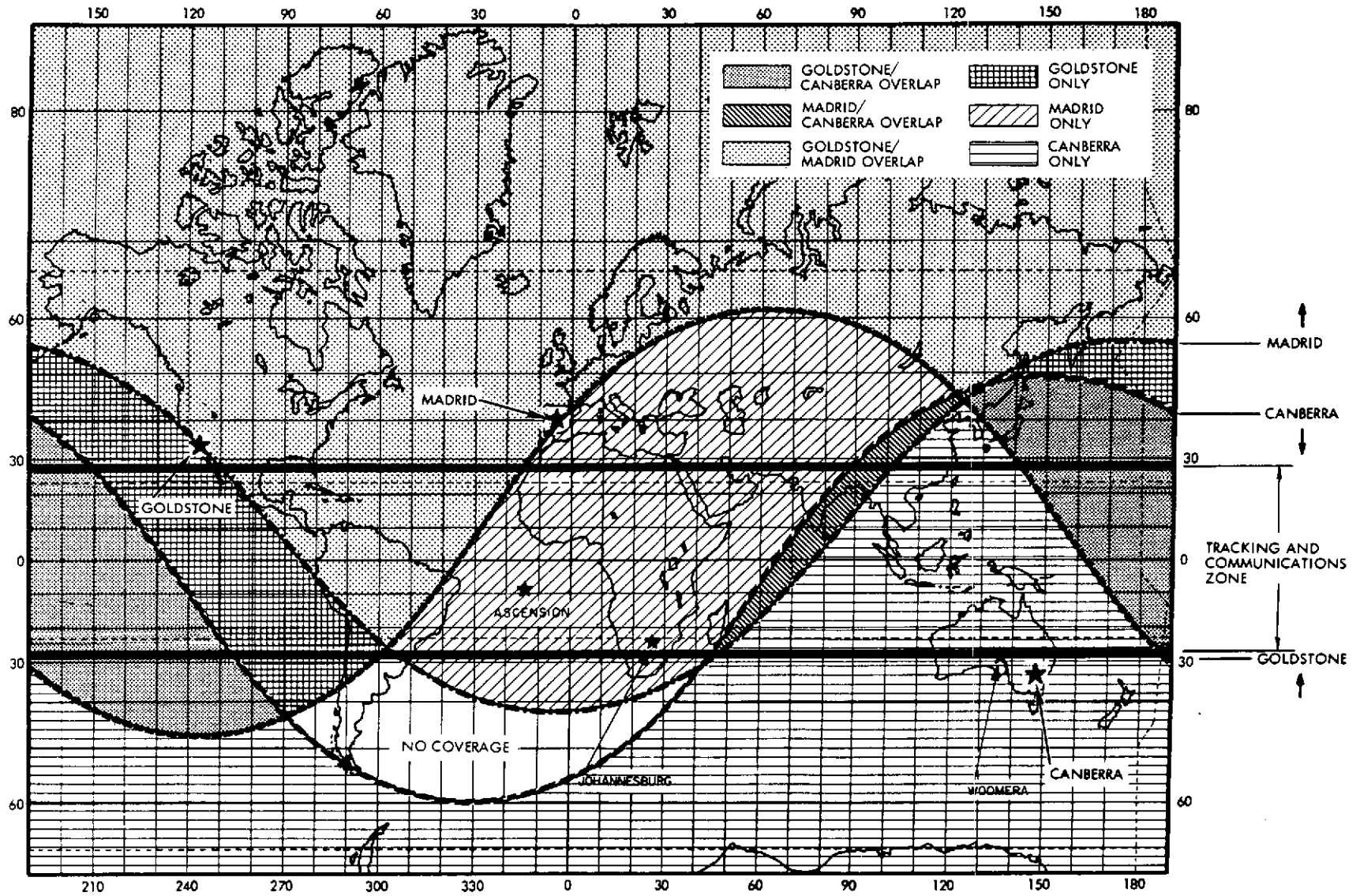

Fig. 1. Continuous coverage of planetary spacecraft provided by the three-station subnet of 64-m antennas operating down to 6-deg elevation (receive mode and 20-kW transmit mode)

ORIGINAL PAGE IS
OF POOR QUALITY

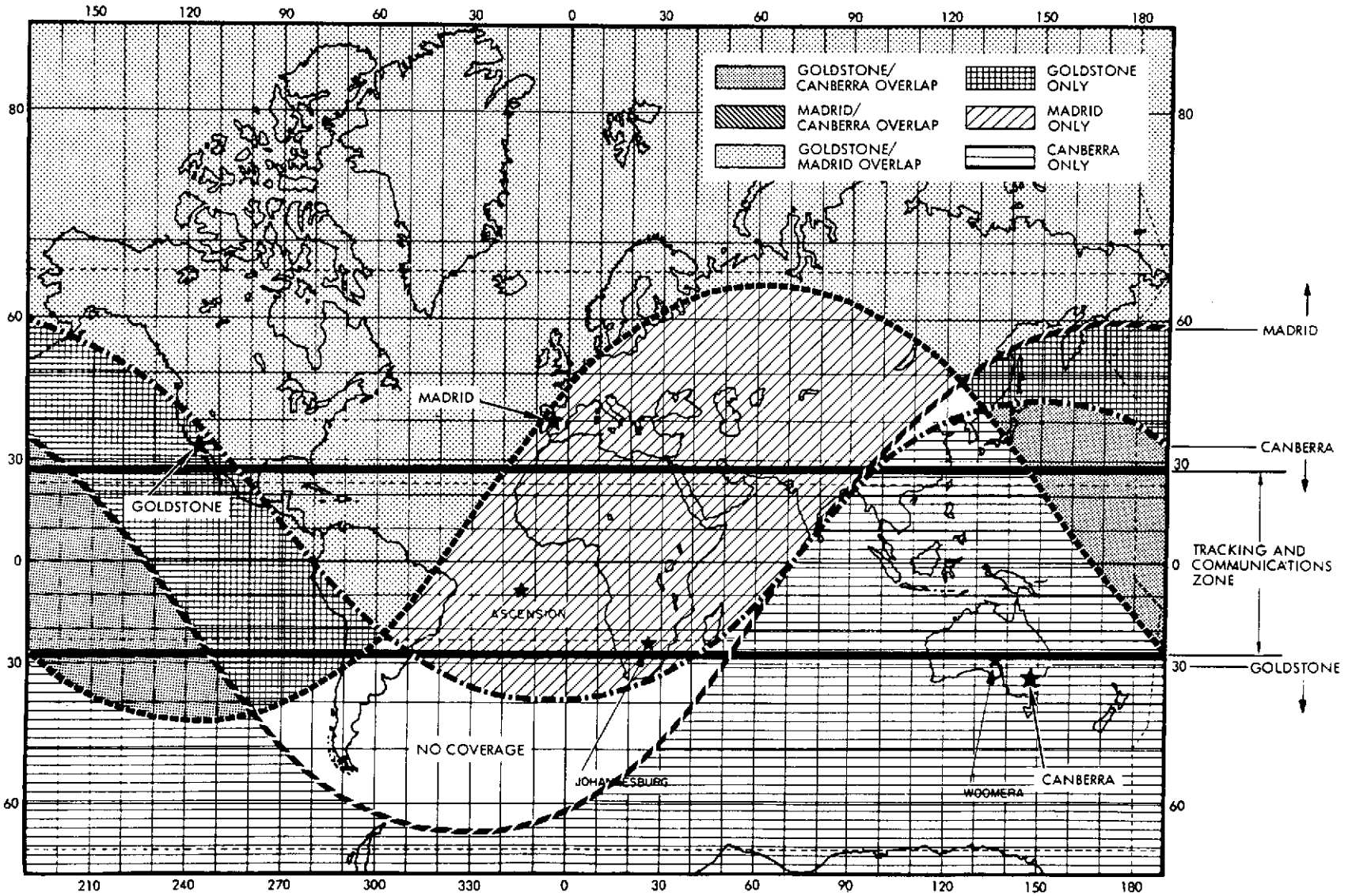

Fig. 2. Continuous coverage of planetary spacecraft provided by the three-station subnet of 64-m antennas operating down to 10-deg elevation (post-1975 era high power transmit mode)

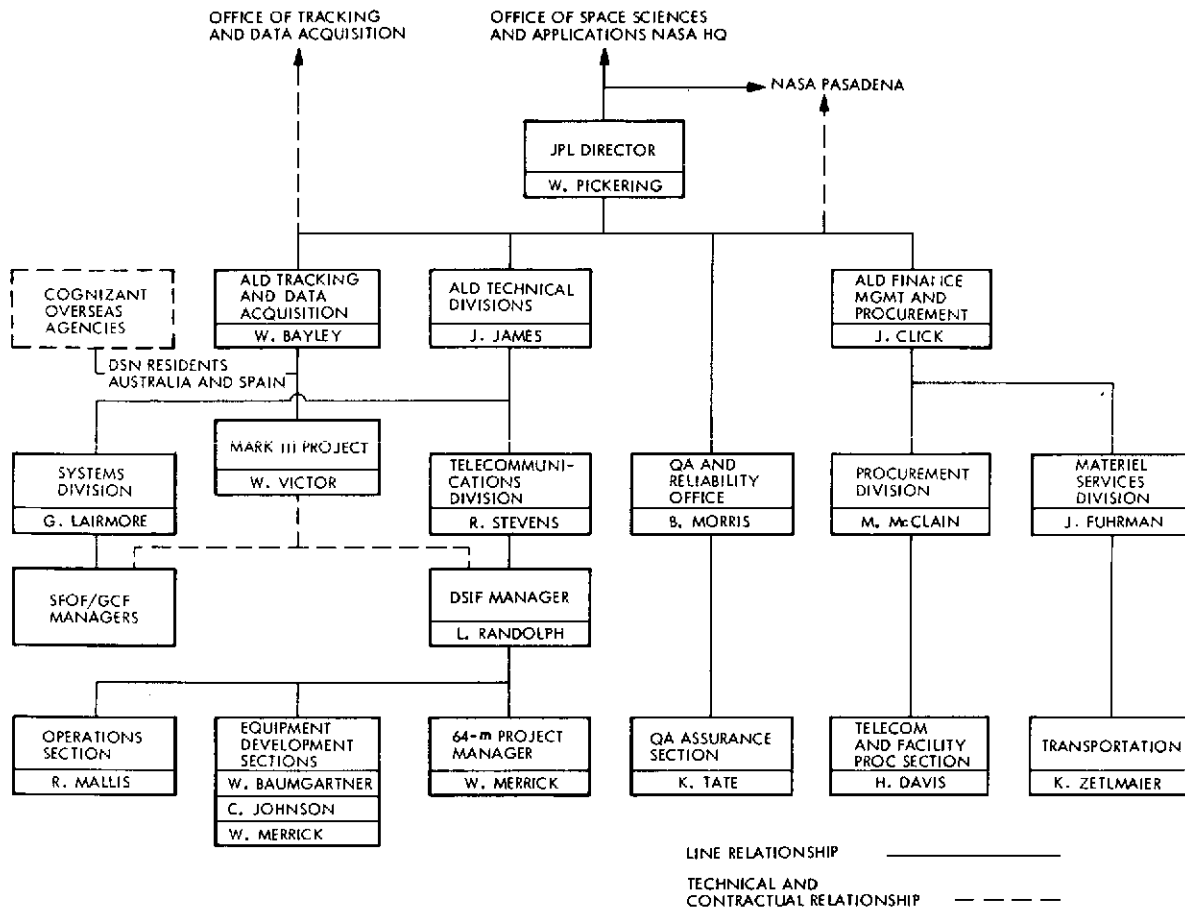

Fig. 3. Overall Organization

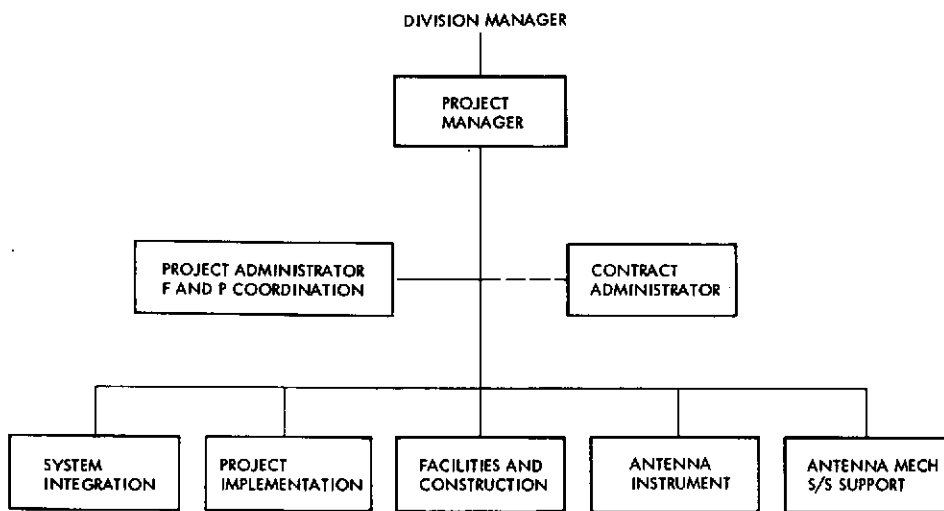

Fig. 4. Work breakdown structure

ORIGINAL PAGE IS
OF POOR QUALITY

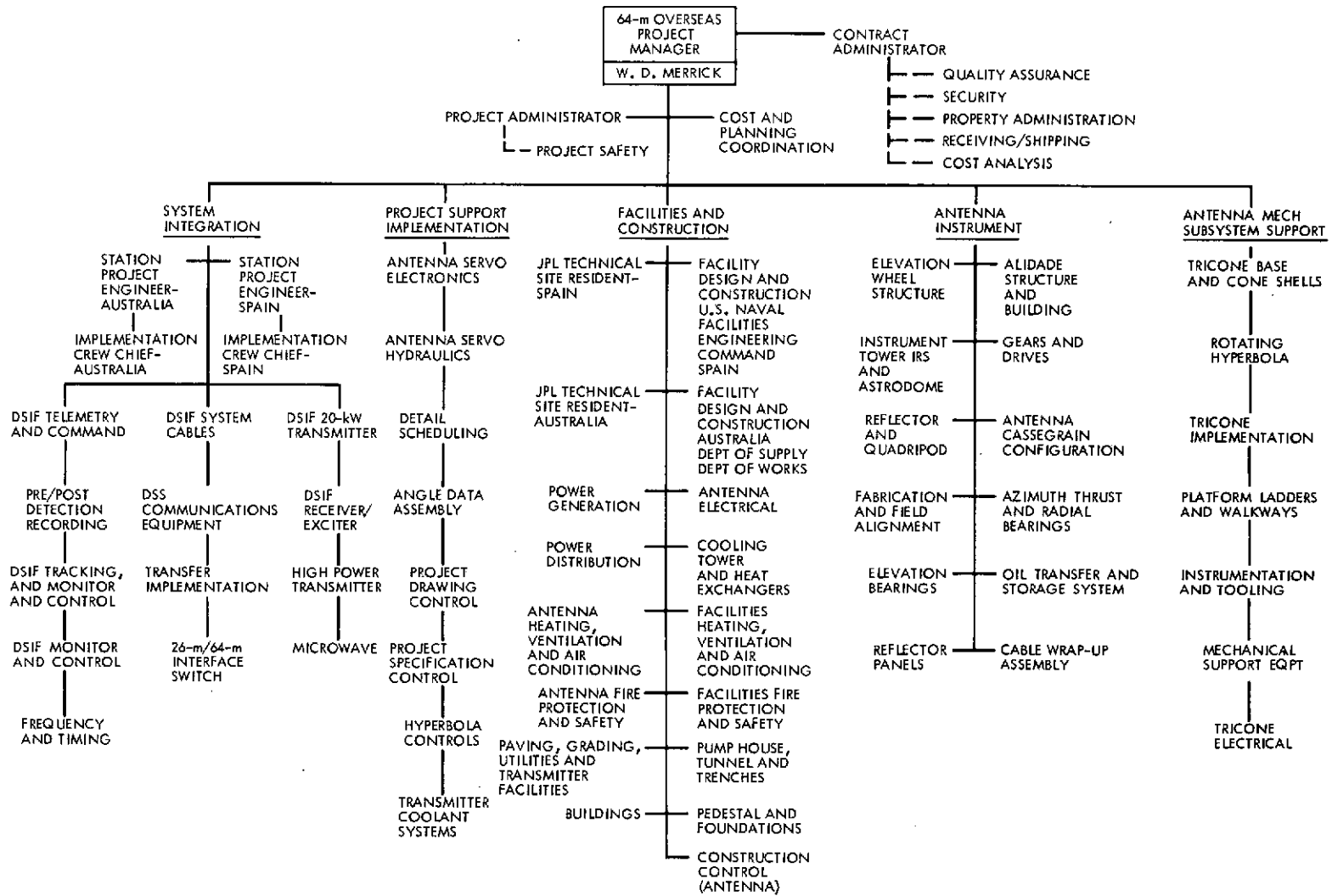

Fig. 5. Project technical organization (functional flow)

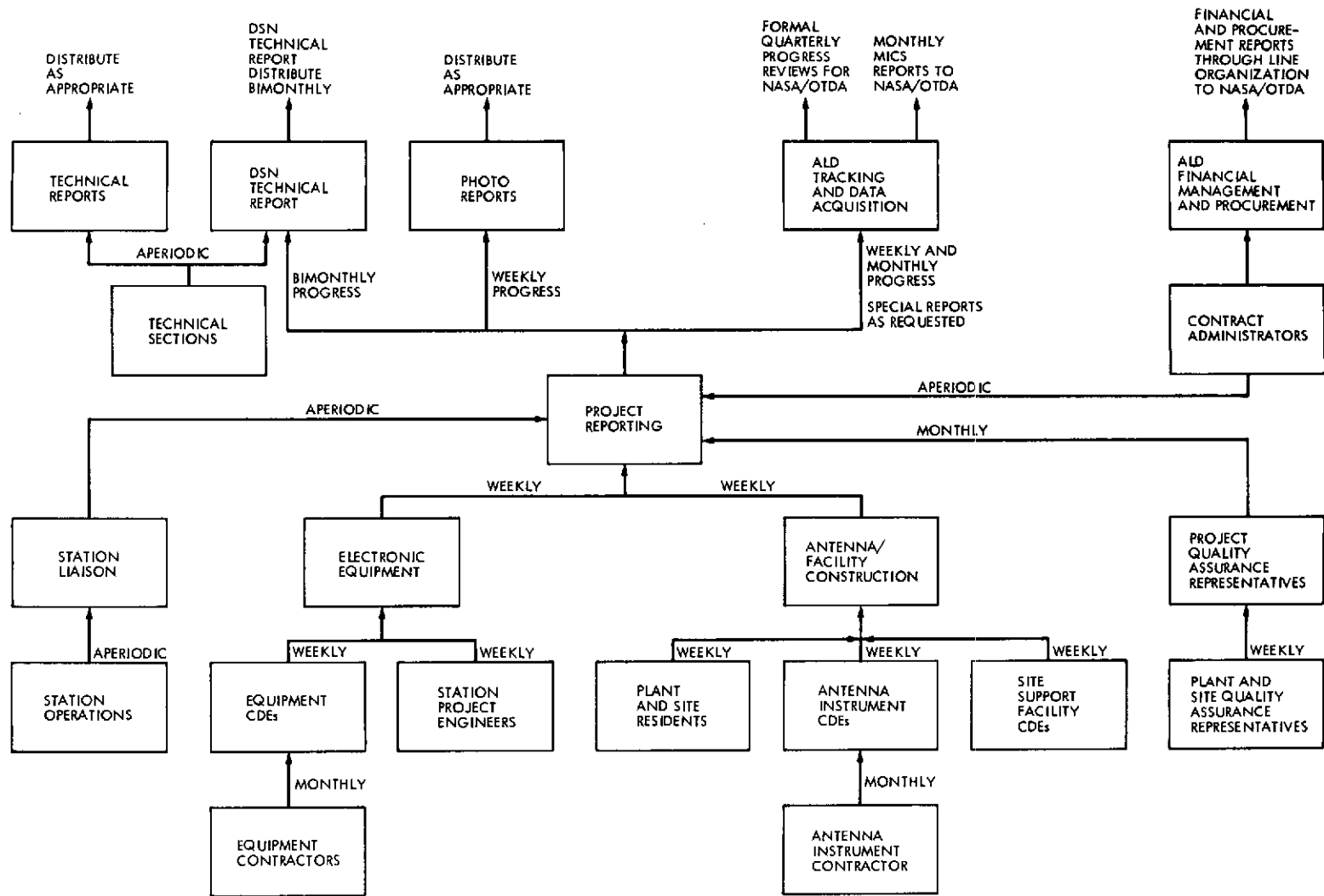

Fig. 6. Project reporting flow

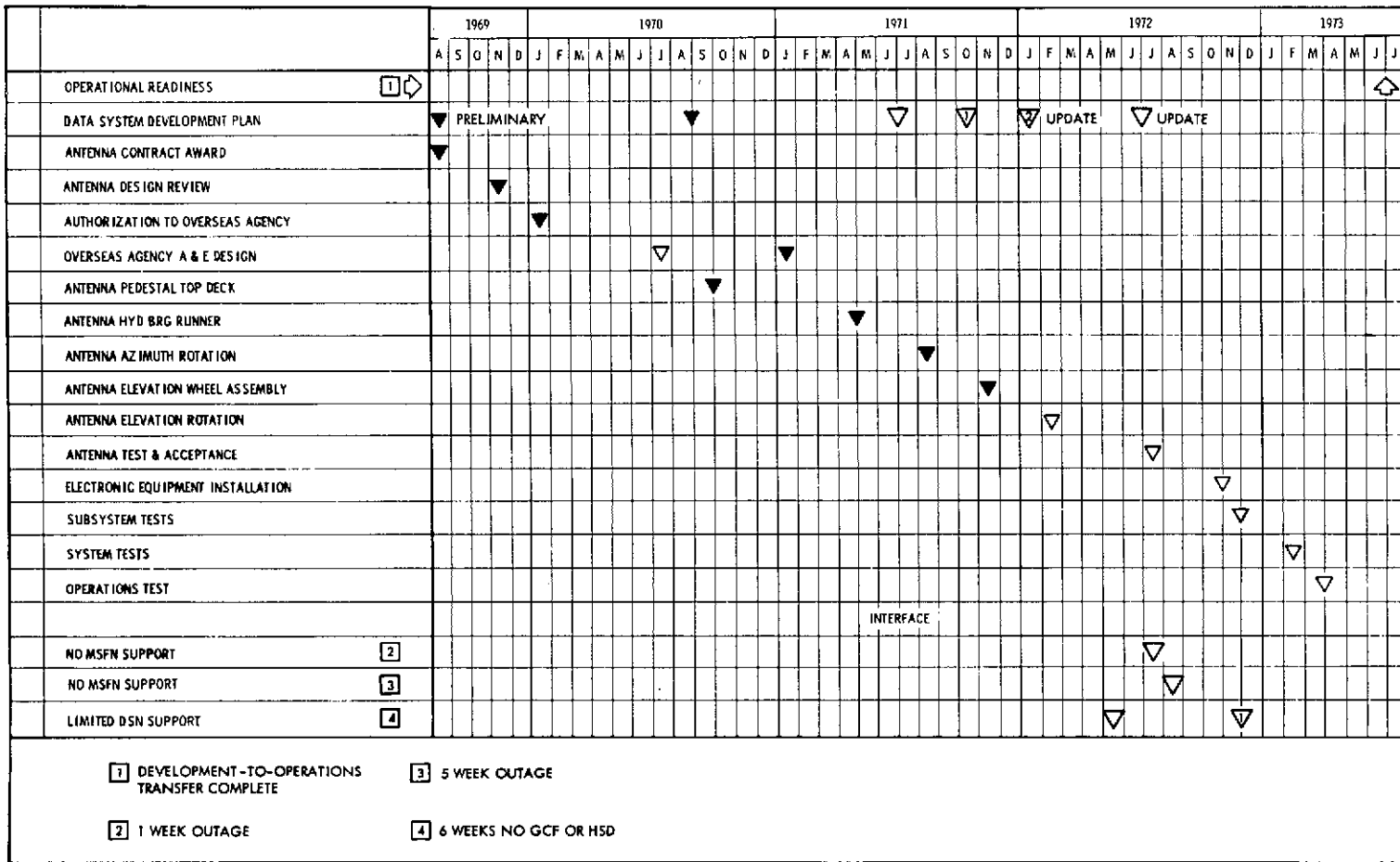

Fig. 7. Master milestone schedule - Australia, start of project

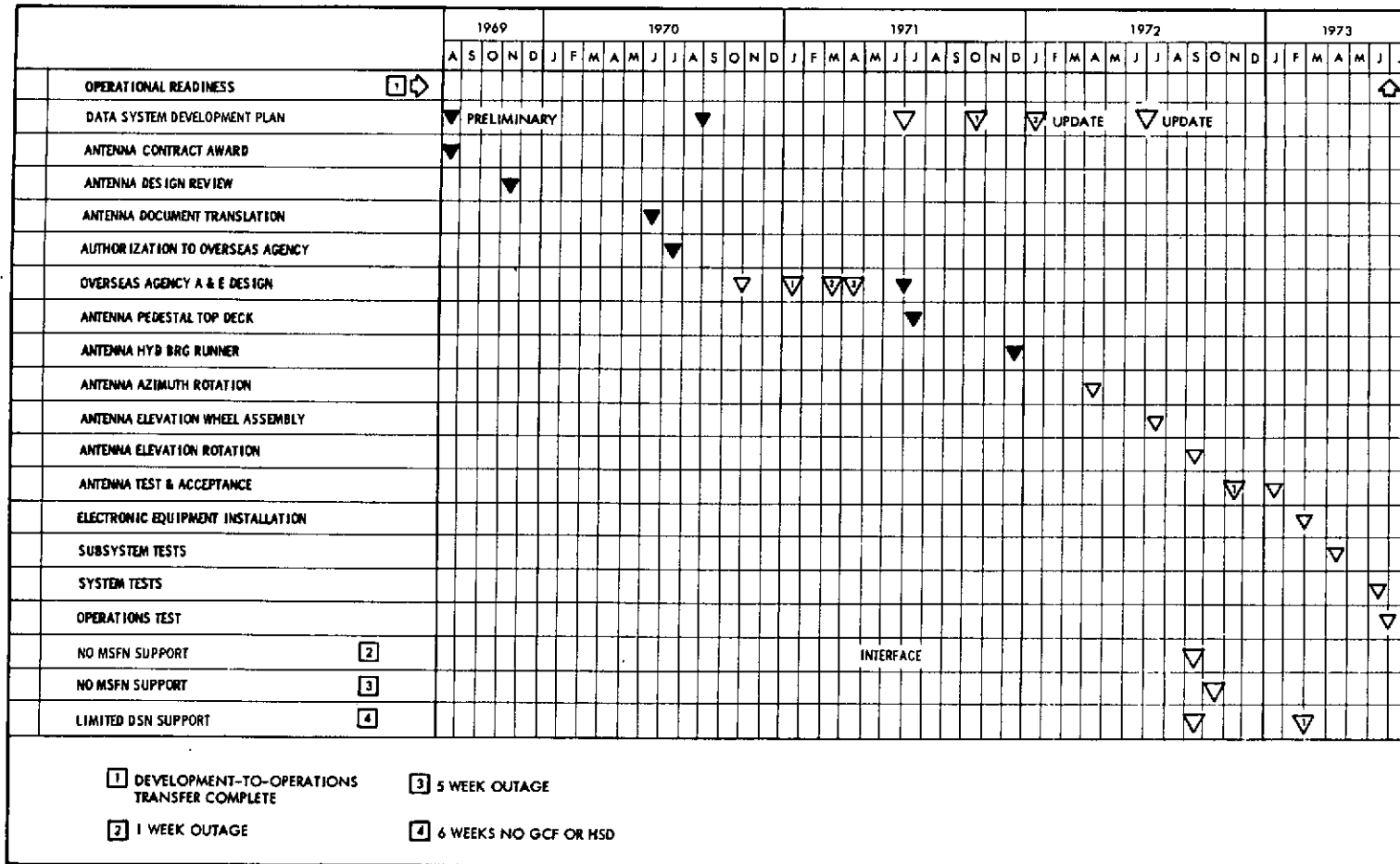

Fig. 8. Master milestone schedule – Spain, start of project

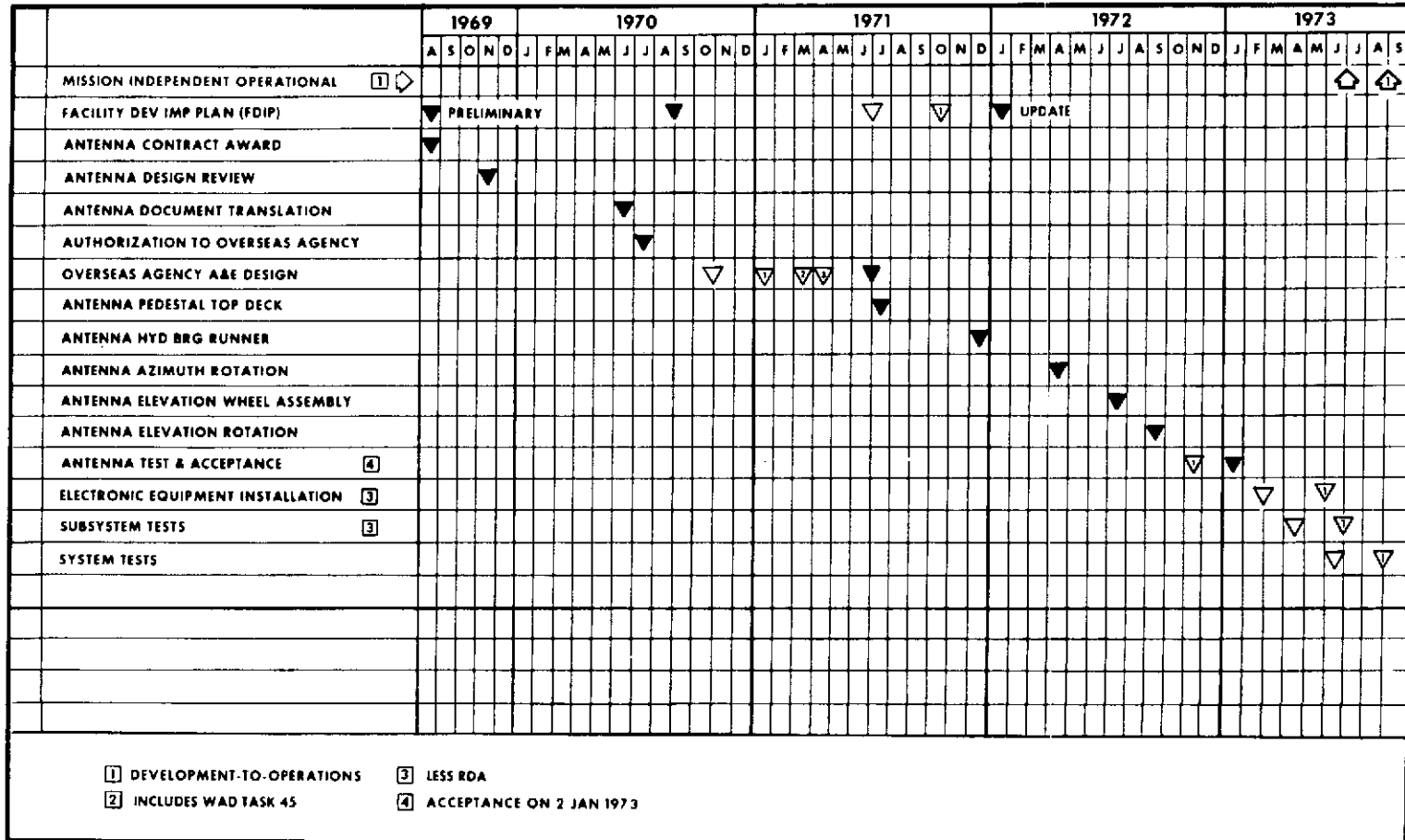

Fig. 10. Master milestone schedule - Spain, actual completion dates

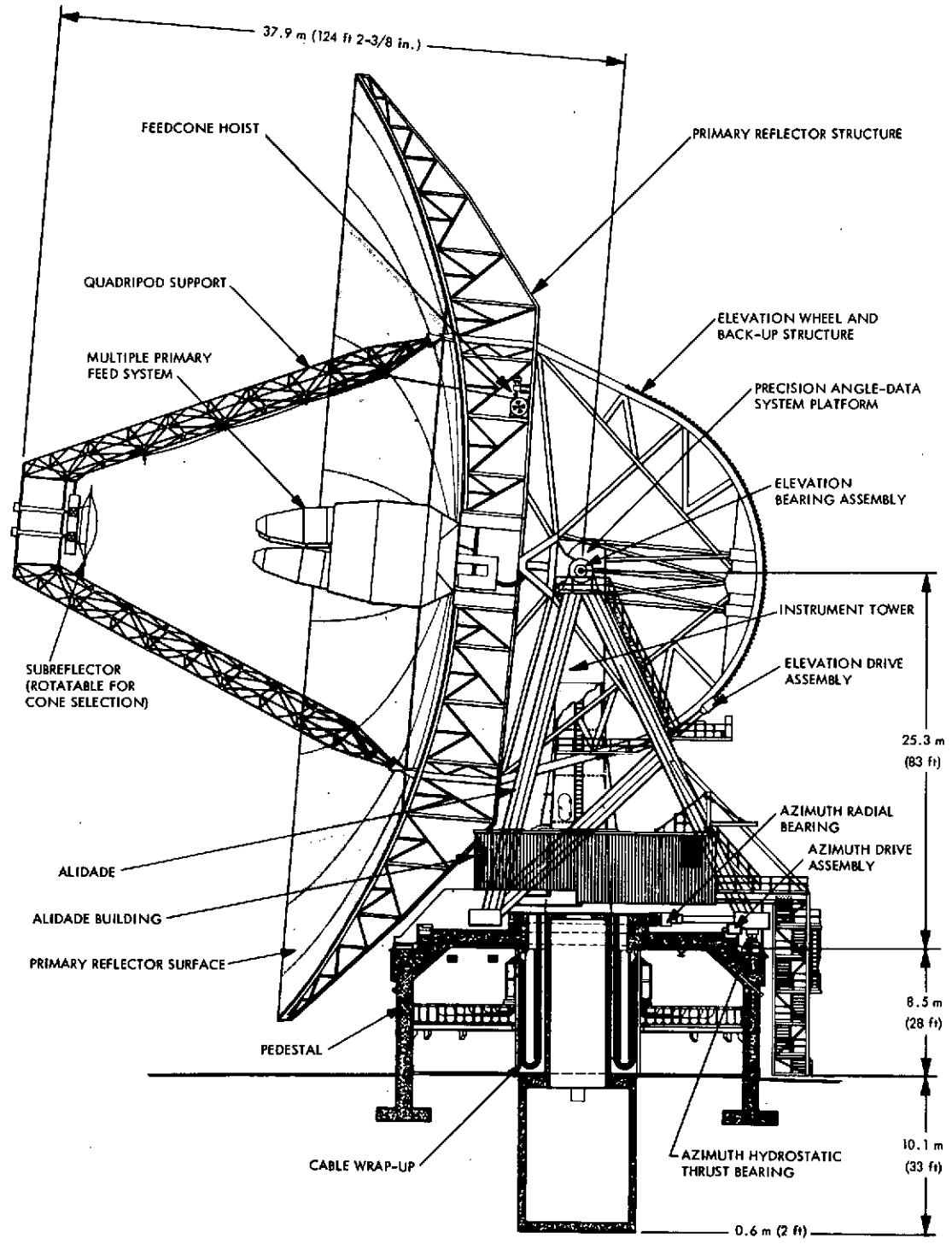

Fig. 11. Antenna major components

ORIGINAL PAGE IS
OF POOR QUALITY

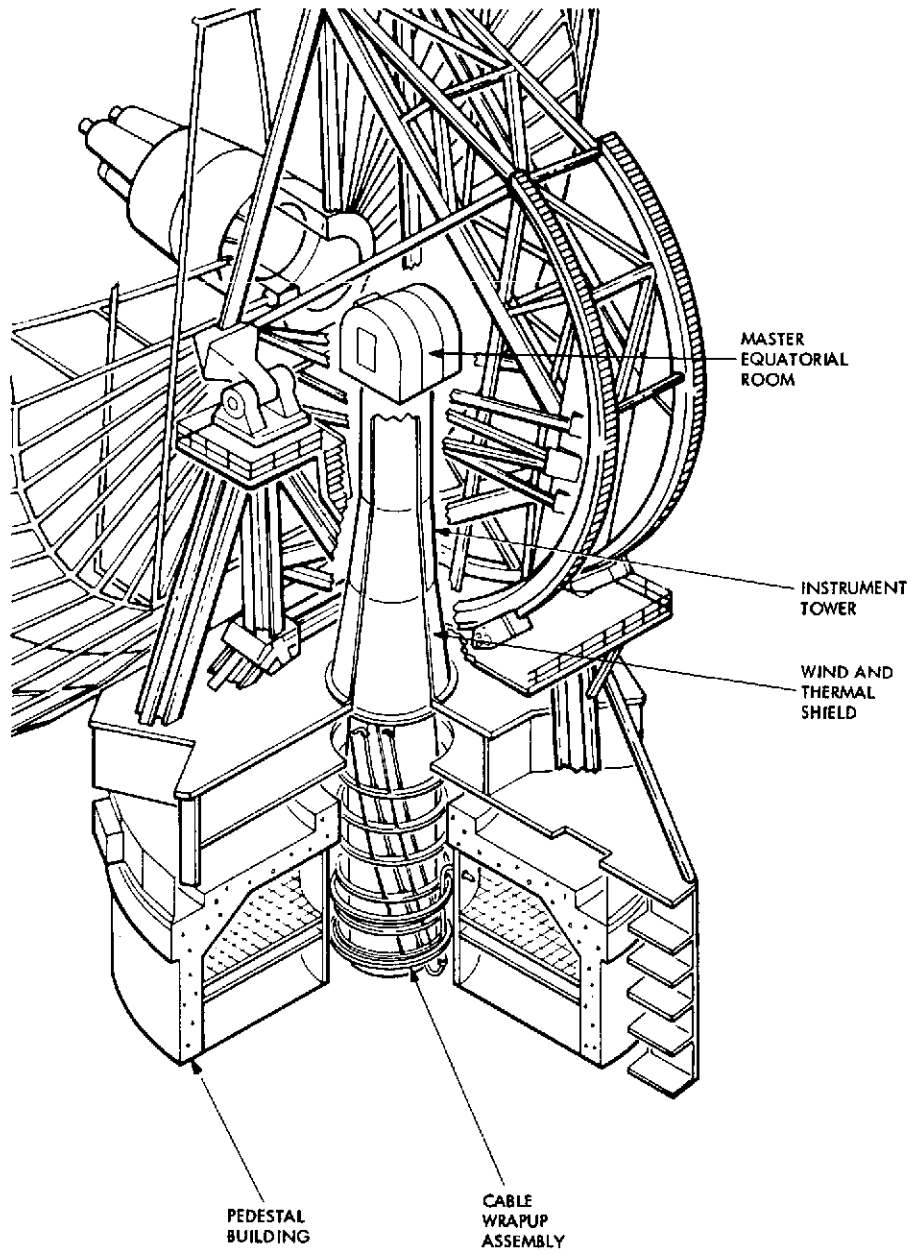

Fig. 12. Pedestal, cable wrapup, and instrument tower

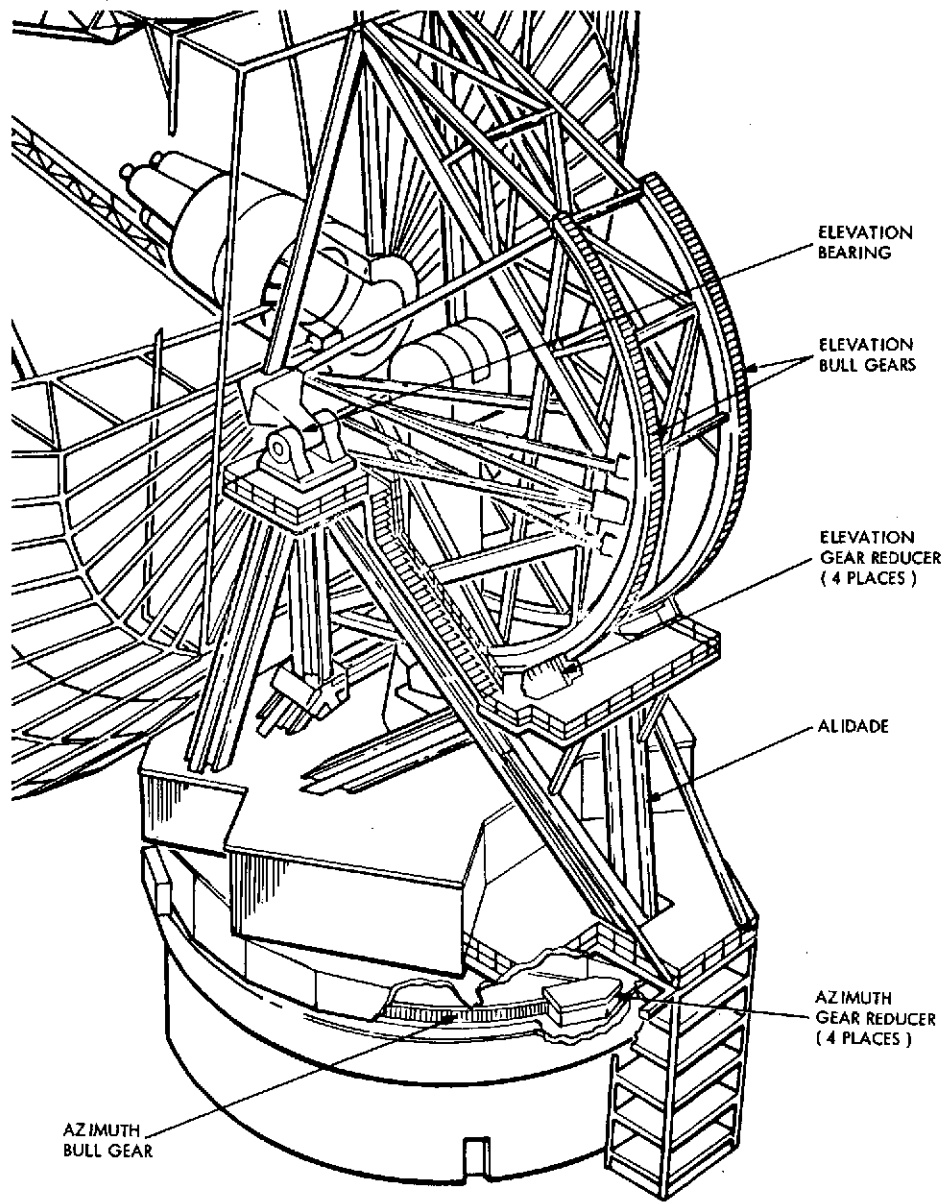

Fig. 13. Antenna mount

ORIGINAL PAGE IS
OF POOR QUALITY

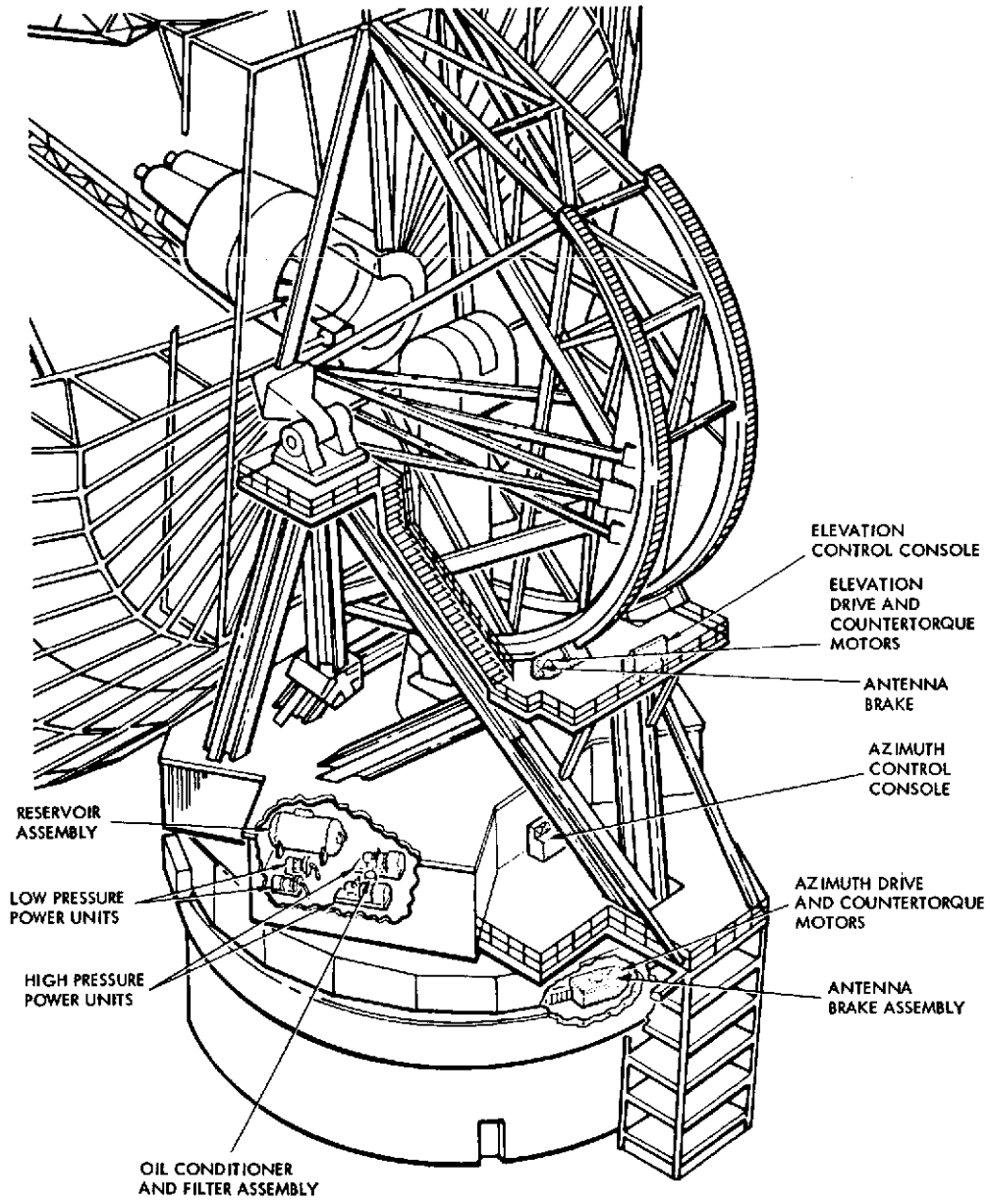

Fig. 14. Servo hydraulics assembly

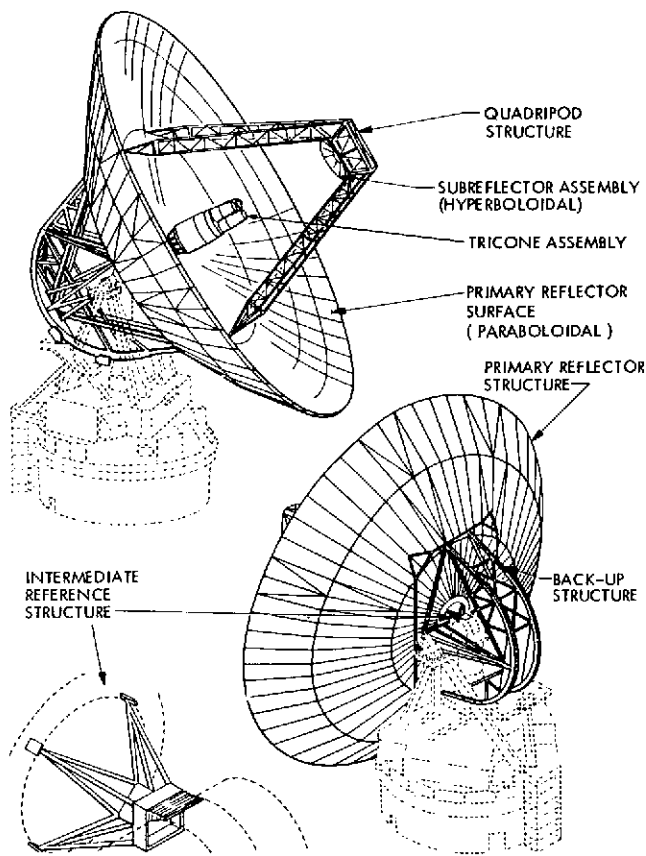

Fig. 15. Tipping assembly

ORIGINAL PAGE IS
OF POOR QUALITY

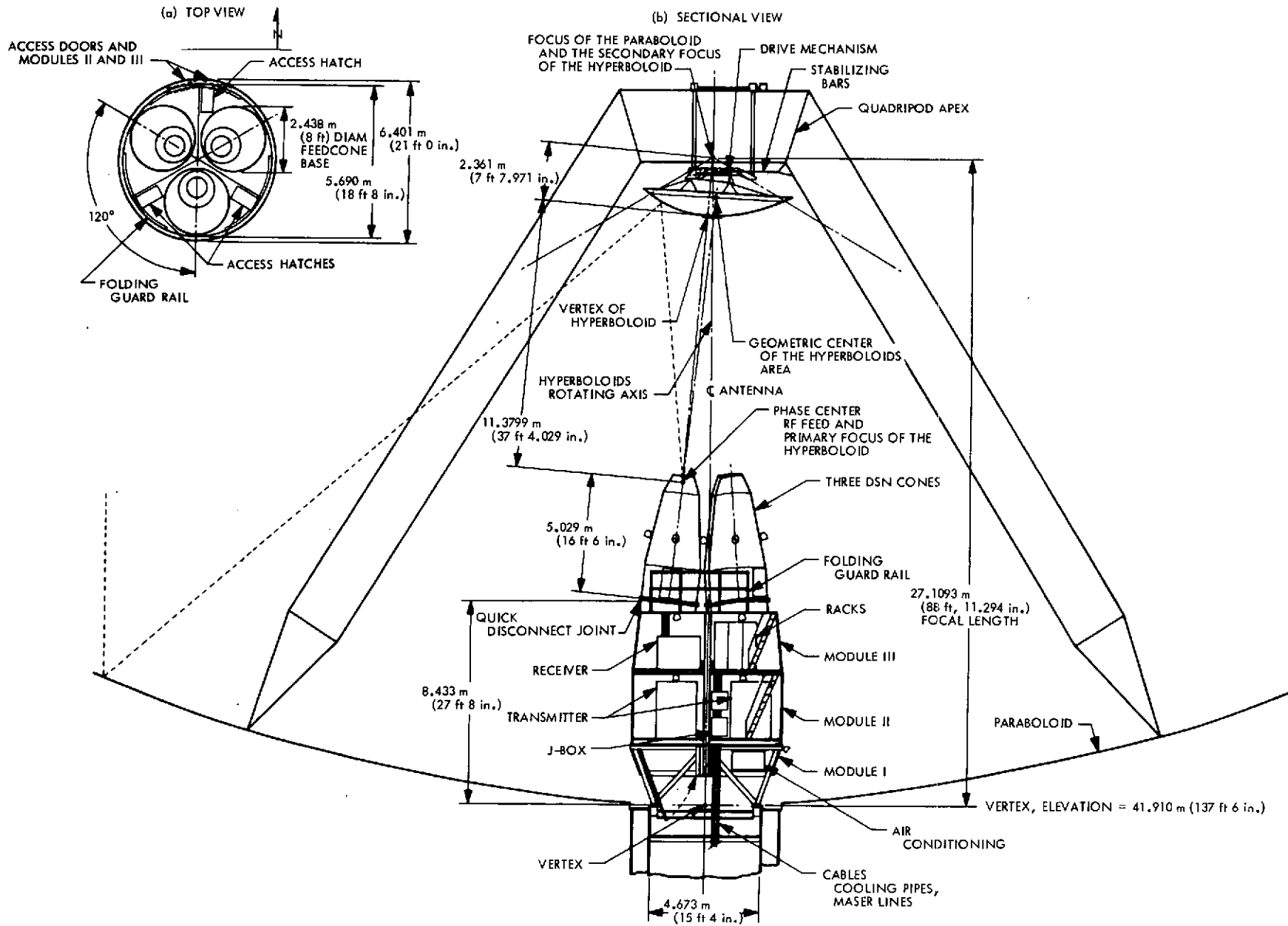

Fig. 16. Multiple primary feed system

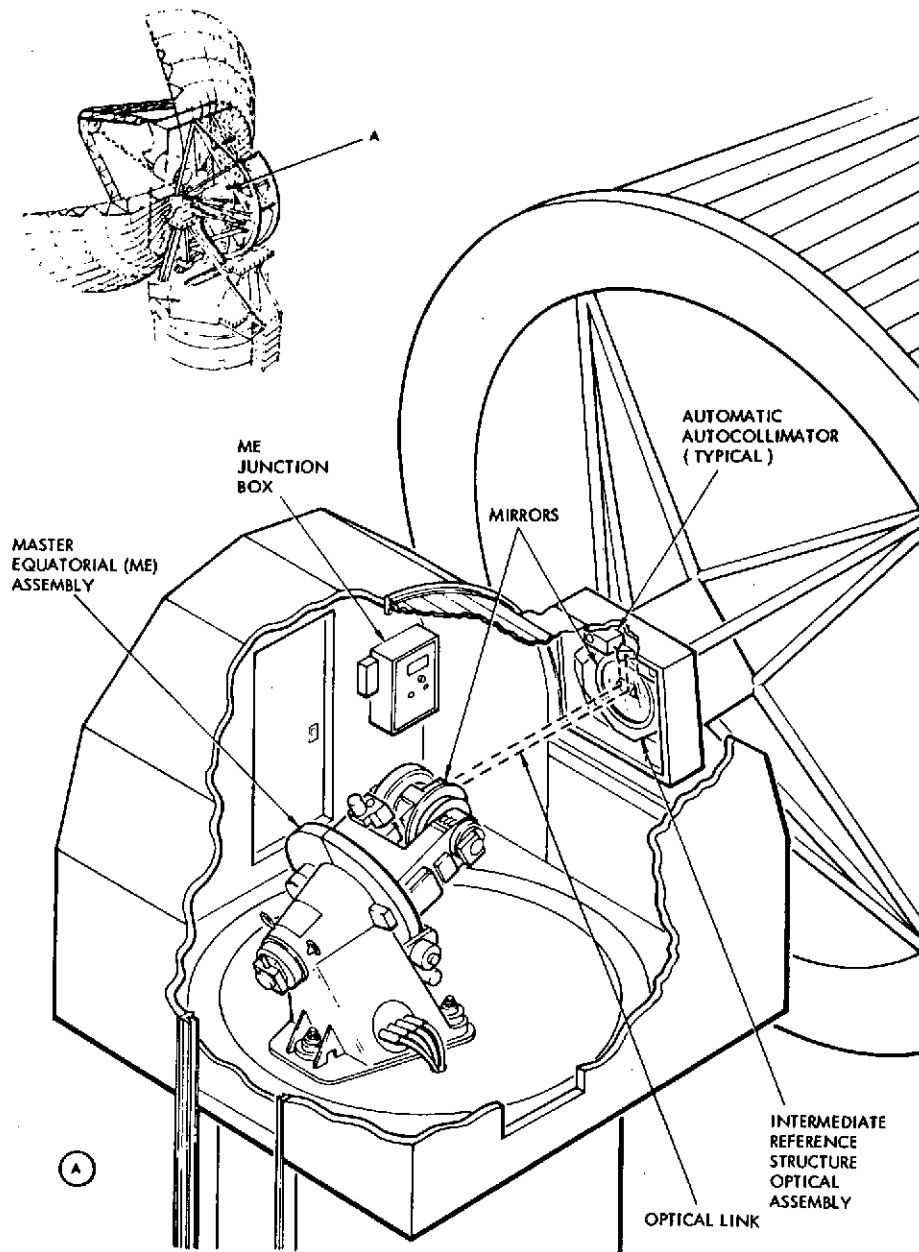

Fig. 17. Angle data assembly antenna mounted components

ORIGINAL PAGE IS
OF POOR QUALITY

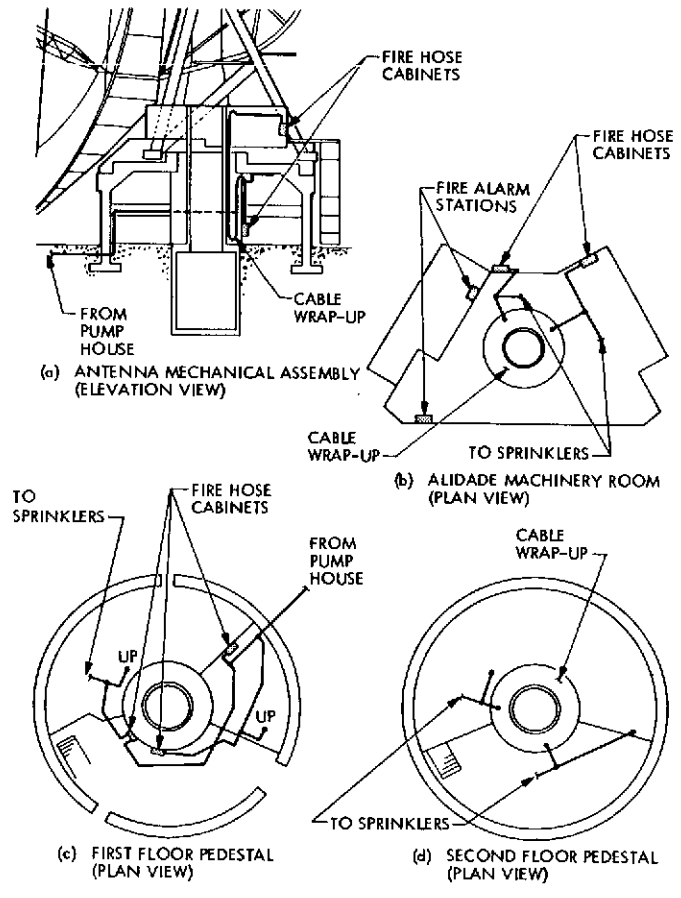

Fig. 18. Fire alarm and water distribution network

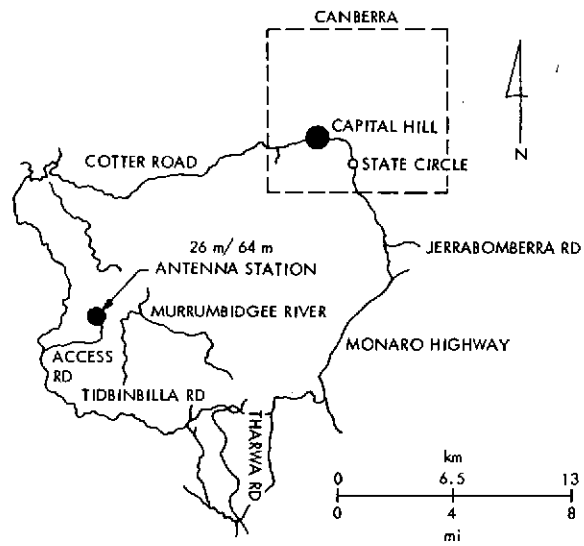

Fig. 19. 26-m/64-m antenna location in Australia

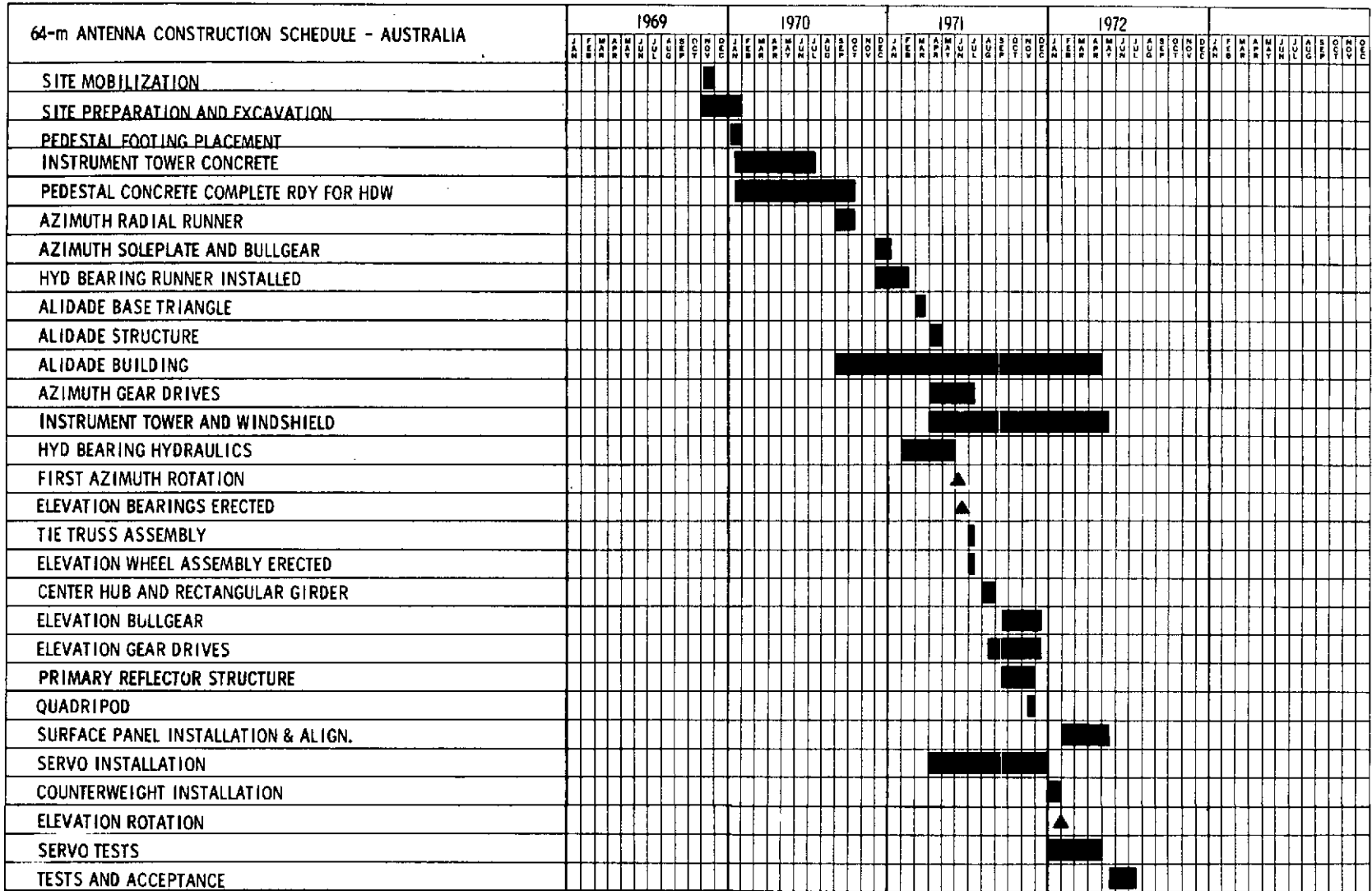

Fig. 20. Construction schedule - Australia

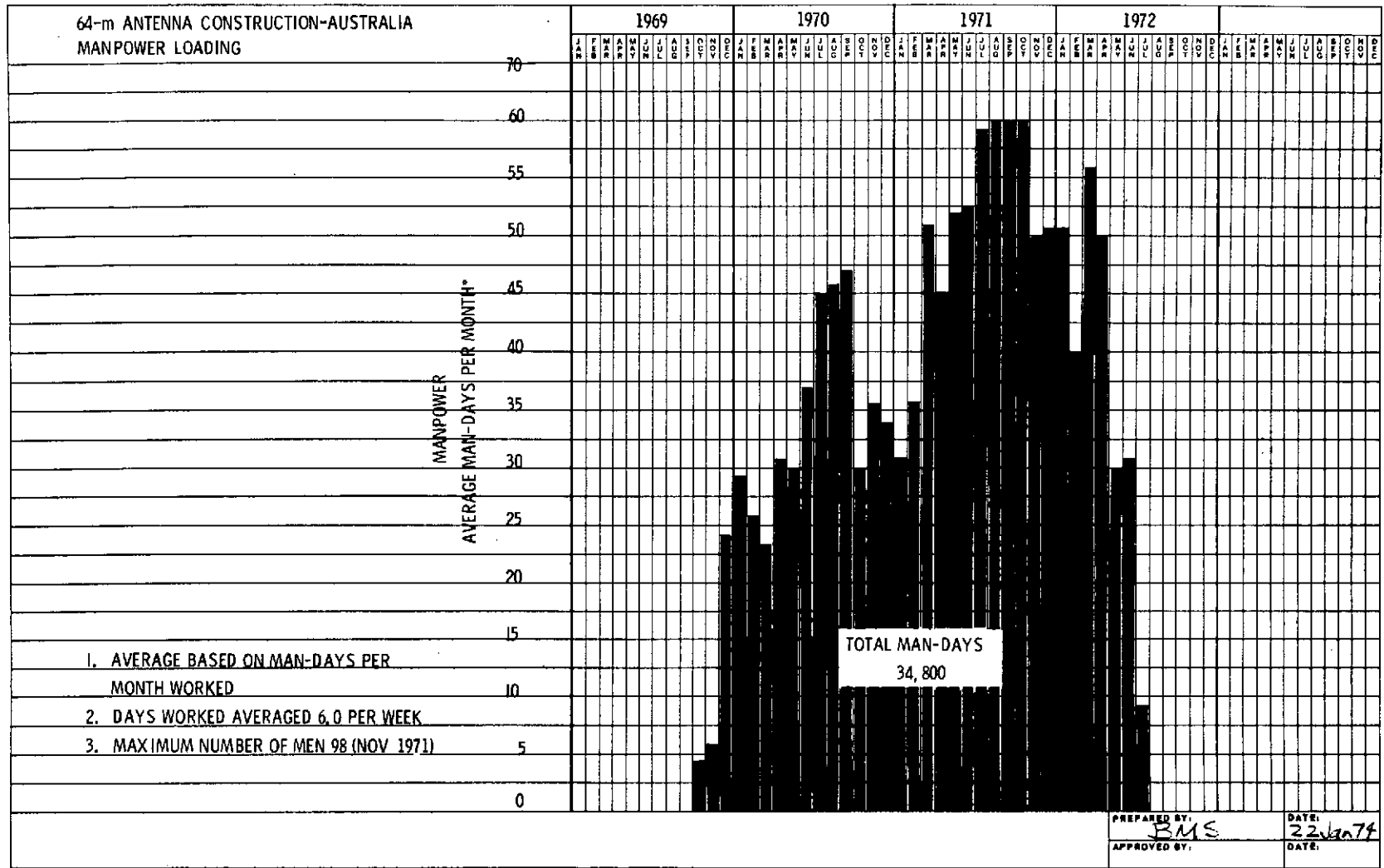

Fig. 21. Contractor (manpower loading - Australia)

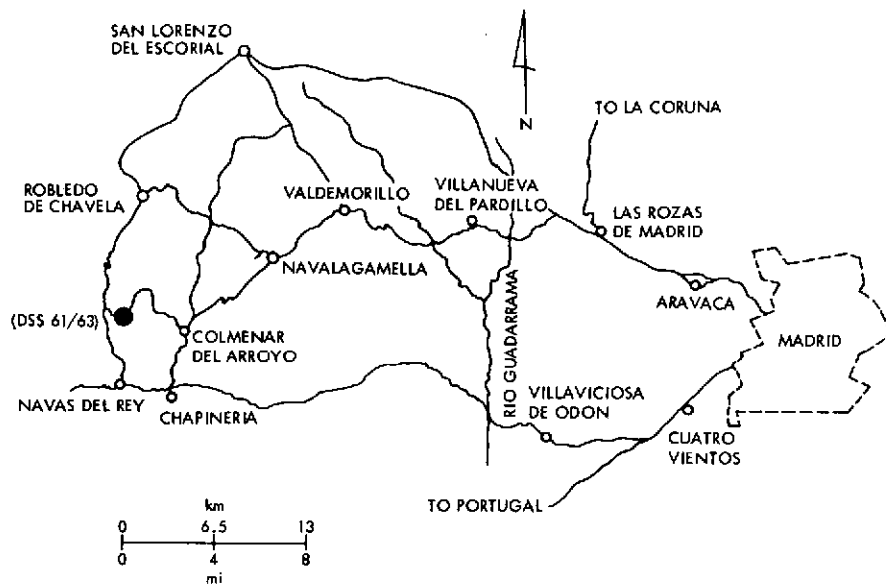

Fig. 22. Site location - Spain

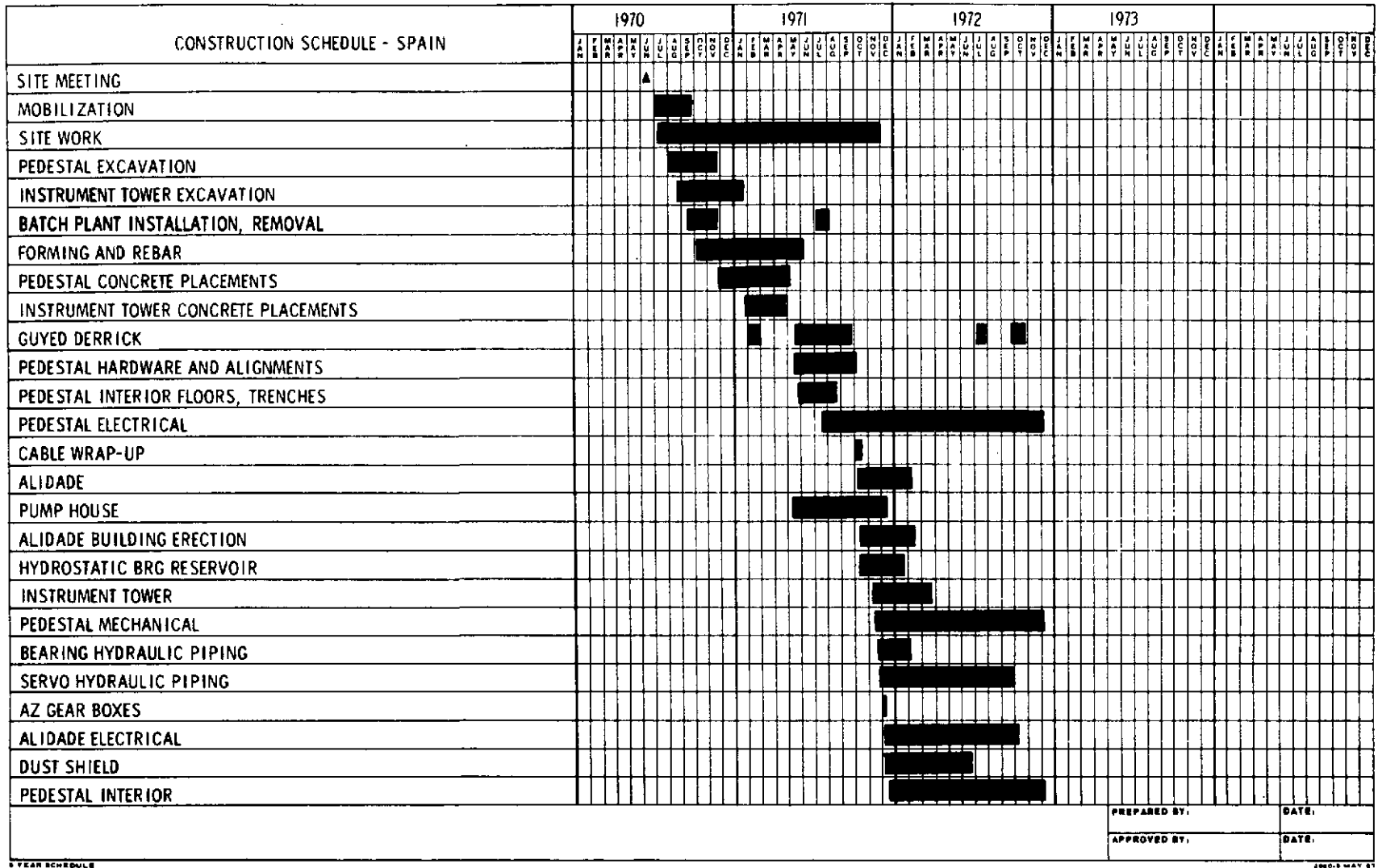

Fig. 23. Construction schedule – Spain

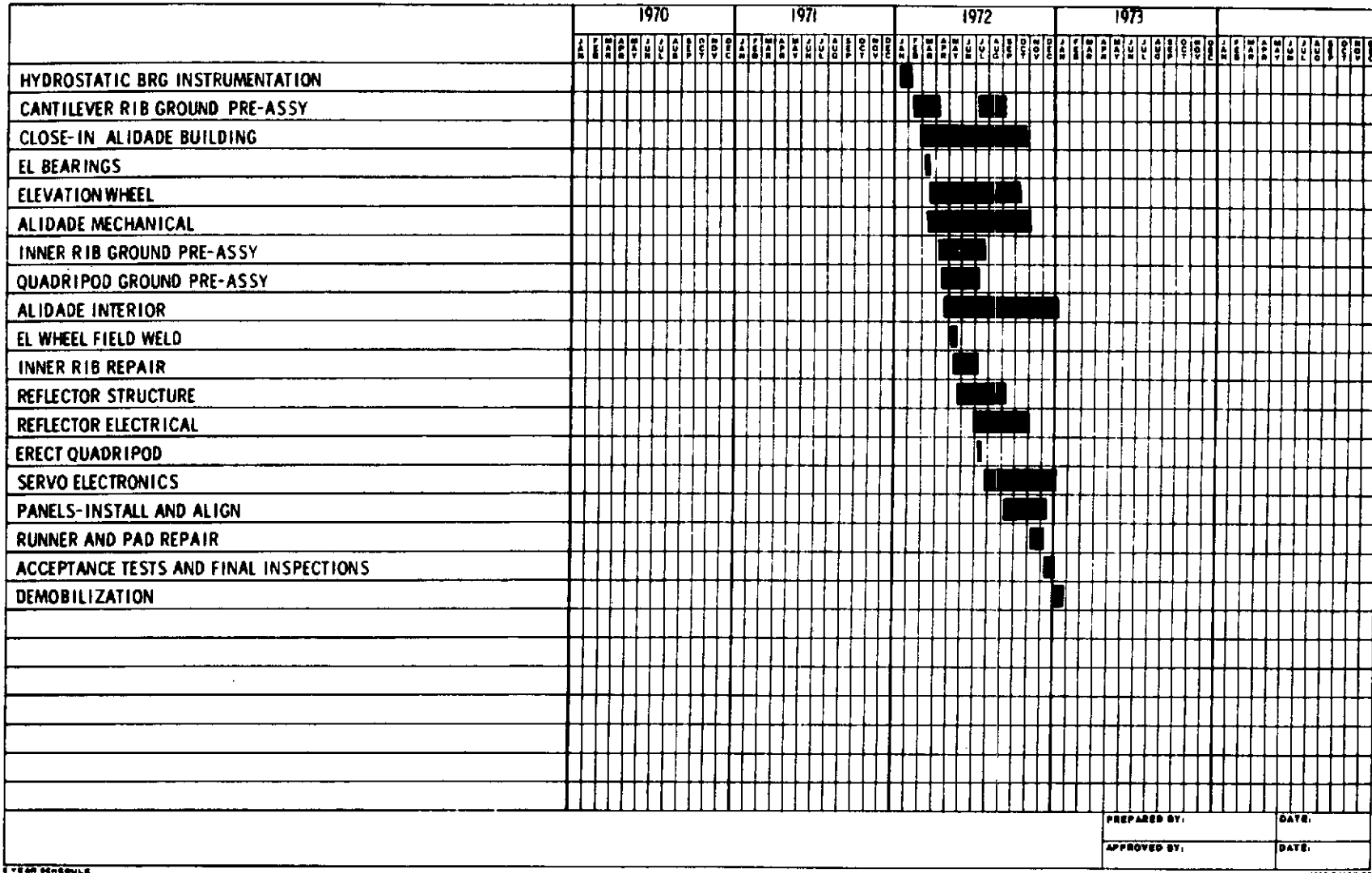

Fig. 23 (contd)

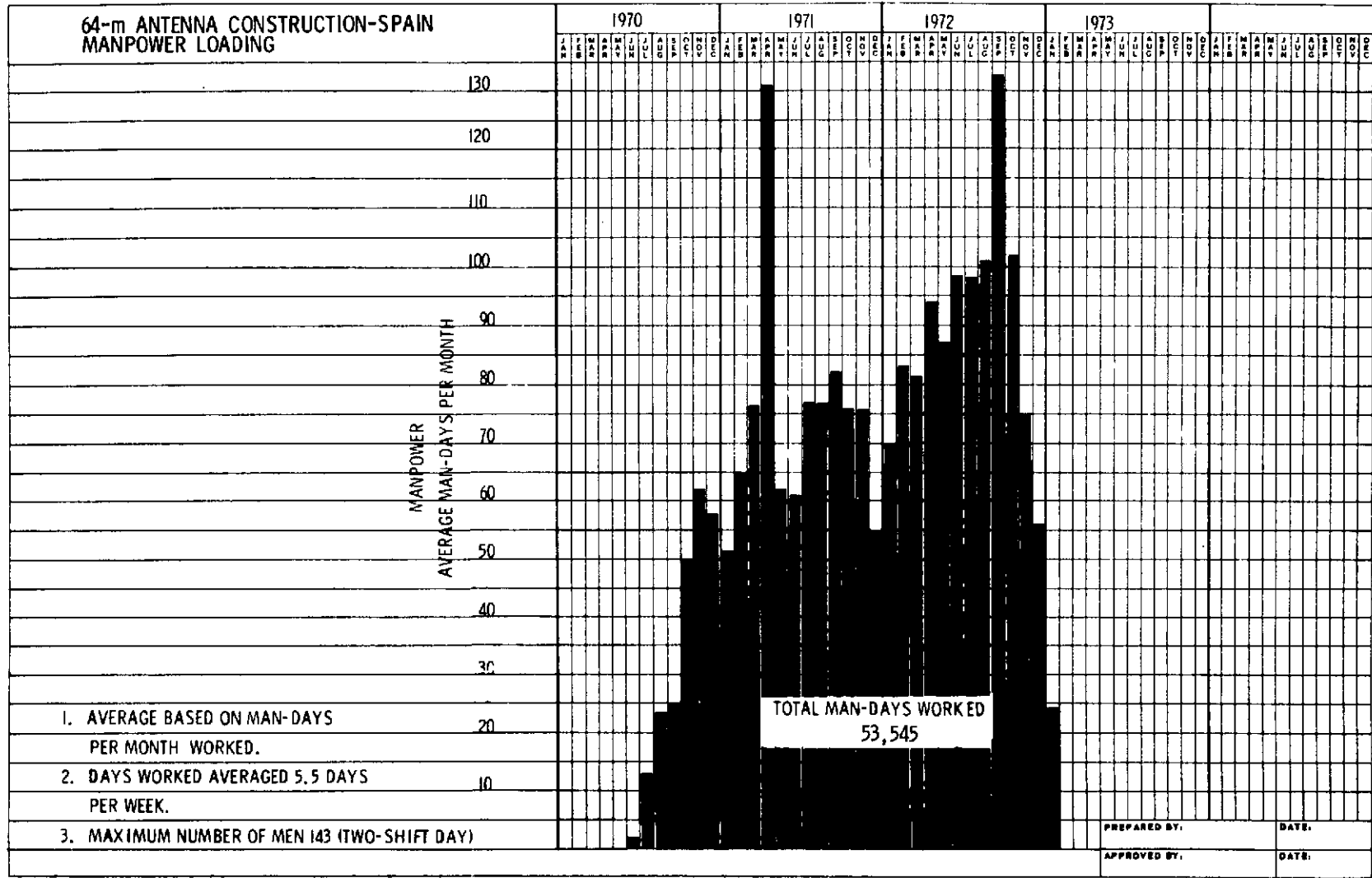

Fig. 24. 64-m antenna construction manpower loading - Spain