

**NASA TECHNICAL  
MEMORANDUM**

**NASA TM X-72650**

**NASA TM X-72650**

WET RUNWAYS

By

Walter B. Horne

(NASA-TM-X-72650) - WET RUNWAYS (NASA) - 23 p.  
HC \$3.25 CACL 01E

N75-20351

Unclas

G3/09 14747



This informal documentation medium is used to provide accelerated or special release of technical information to selected users. The contents may not meet NASA formal editing and publication standards, may be revised, or may be incorporated in another publication.

**NATIONAL AERONAUTICS AND SPACE ADMINISTRATION  
LANGLEY RESEARCH CENTER, HAMPTON, VIRGINIA 23665**

1. Report No. TM X-72650		2. Government Accession No.		3. Recipient's Catalog No.	
4. Title and Subtitle Wet Runways				5. Report Date APRIL 1975	
				6. Performing Organization Code	
7. Author(s) Walter B. Horne				8. Performing Organization Report No.	
9. Performing Organization Name and Address NASA Langley Research Center Hampton, VA 23665				10. Work Unit No. 505-08-31-01	
				11. Contract or Grant No.	
12. Sponsoring Agency Name and Address National Aeronautics & Space Administration Washington, DC 20546				13. Type of Report and Period Covered Technical Memorandum	
				14. Sponsoring Agency Code	
15. Supplementary Notes					
16. Abstract <p>This paper defines and discusses some important parameters associated with aircraft stopping and directional control performance on wet runways. The major elements affecting tire/ground traction developed by jet transport aircraft are identified and described in terms of atmospheric, pavement, tire, aircraft system and pilot performance factors or parameters. Where possible, research results are summarized, and means for improving or restoring tire traction/aircraft performance on wet runways are discussed.</p>					
17. Key Words (Suggested by Author(s)) (STAR category underlined) Aircraft                      Tire Landing                      Friction Performance			18. Distribution Statement  Unclassified - Unlimited		
19. Security Classif. (of this report) Unclassified		20. Security Classif. (of this page) Unclassified		21. No. of Pages 21	22. Price* \$3.25

\*Available from { The National Technical Information Service, Springfield, Virginia 22151  
STIF/NASA Scientific and Technical Information Facility, P.O. Box 33, College Park, MD 20740

SUPPLEMENTARY DISTRIBUTION OF TM X-72650  
ENTITLED "WET RUNWAYS" BY WALTER B. HORNE

	<u>Copies</u>	<u>Copy No.</u>
Mr. Charles McKinnon Executive Vice President Aerospace Management Services International Suite 1004 1117 North 19th Street Arlington, VA 22209	1	
Mr. Paul M. Johnstone Vice President, Engineering Eastern Airlines International Airport Miami, FL 33148	1	
Mr. C. O. Miller Consultant, Systems Safety 7722 Bridle Path Lane McLean, VA 22101	1	
Mr. S. T. Aoyagi Manager, Flight Operations The Americas Suite 128 1818 Gilbreth Road Burlingame, CA 94010	1	
Captain Franco Ferreira Office of Air Attaché 30006 Massachusetts Ave., NW Washington, DC 20008	1	
Mr. Hiroshi Murohara Senior Flight Crew Office ALL NIPPON Airways Co., Ltd. Tokyo International Airport Tokyo, Japan 144	1	
Mr. R. M. Kidd Director, Technical and Safety Canadian Air Line Pilots Association 9675 Cote de Liesse Road Dorval, P. Quebec H9P1A3	1	

## WET RUNWAYS

by Walter B. Horne

### SUMMARY AND ABSTRACT

This paper defines and discusses some important parameters associated with aircraft stopping and directional control performance on wet runways. The major elements affecting tire/ground traction developed by jet transport aircraft are identified and described in terms of atmospheric, pavement, tire, aircraft system and pilot performance factors or parameters. Where possible, research results are summarized, and means for improving or restoring tire traction/aircraft performance on wet runways are discussed.

### INTRODUCTION

The introduction of the modern jet transport into airline service in the late 1950's was followed by the realization in approximately 1960 that this new aircraft type was much more susceptible to wet runway stopping and directional control problems than the piston engine type aircraft the jet transports replaced. As a result, wet runway research in the United States and Europe was greatly intensified. Over the past 17 years this research (refs. 1-22) has produced significant "milestones" for developing better physical understanding and methods for alleviating jet transport operational problems on wet runways.

Among these "milestones" were dynamic and viscous hydroplaning theory (1960), "reverted" rubber hydroplaning theory (1965), porous asphalt overlays (1965), and deep grooving of operational runways (1967). More recently, several joint FAA/USAF/NASA runway research programs, utilizing instrumented aircraft and ground vehicles, have been successful in isolating causes for anomalous aircraft antiskid braking system operation on wet slippery runways, and establishing relationships between aircraft and ground vehicle measurements of wet runway slipperiness.

It is the main purpose of this paper to define and discuss the important atmospheric, pavement, tire, aircraft, and pilot parameter combinations that result in good aircraft stopping and directional control performance on wet runways. Of equal importance is the definition and recognition of parameter combinations that can result in poor aircraft stopping and directional control performance on wet runways.

### FACTORS AFFECTING AIRCRAFT WET RUNWAY PERFORMANCE

The major factors affecting aircraft wet runway performance are listed in figure 1. This figure is used as a "roadmap" to point out that the water

depth present on the runway at the time of landing combines with aircraft ground speed, to define the friction coefficient at the tire/pavement interface that is available to the pilot/aircraft for stopping and directional control purposes. Under good interfacial drainage conditions, this available friction on wet runways may remain near dry runway levels with correspondingly similar aircraft stopping and directional performance.

However, when rainfall rates are high, and/or when the tire/pavement drainage capability is poor, the available friction coefficient can drop drastically, especially at the higher aircraft ground speeds. Under these low tire/pavement traction conditions on the runway, research shows that operational characteristics of the aircraft braking and steering systems, pilot steering and braking inputs, surface winds, and tire mechanical properties often combine and interact in such a way only a small fraction of this already low tire/pavement traction can actually be utilized by the aircraft for stopping and directional control purposes.

Runway water depth.- The main parameters affecting runway water depth are listed in figure 1. An optimum runway design is one that delays surface flooding during natural rain until less frequent high rainfall rates are reached, such as the grooved runway shown in figure 2. In general, runway water depths increase with increasing rainfall intensity and drainage path lengths, and decrease with increasing runway transverse slope and surface macrotecture (ref. 19). Surface winds do not affect runway water drainage appreciably until surface flooding occurs, and water then flows as a sheet along the runway surface. At this point, surface winds tend to increase drainage path lengths and can greatly increase water depths on the runway, depending upon the wind magnitude and direction as shown in figure 2. The horizontal lines drawn in figure 2 qualitatively indicate the critical water depths required for dynamic tire hydroplaning to occur when the aircraft on the runway is traveling at speeds greater than the tire hydroplaning speed. During this speed and water depth regime, the aircraft is like a sailboat without a keel, and is hard to steer and stop without lateral drift (in crosswinds), due to absence of tire cornering and braking forces. It should be noted that on crowned runways, minimum water depths are encountered by aircraft tires when the pilot lands and maintains a course directly down the runway centerline. (Minimum drainage path lengths for aircraft tires are obtained.)

Tire/pavement drainage capability.- When water is deposited on runways during rainstorms, a water removal or drainage problem is created at tire/pavement interfaces of the moving aircraft. The stationary water intercepted by the translating/rotating aircraft tires must be rapidly expelled from the tire/pavement contact zone or viscous and dynamic water pressures buildup with increasing ground speed as shown in figure 3. When the average water pressure developed between the tire and pavement surface equals the tire inflation pressure, total dynamic or viscous hydroplaning occurs, and the tire is supported on a water layer or film and is no longer in direct contact with the pavement. In this situation tire braking and cornering forces are almost zero, due to the inability of a fluid (water) to support shear forces of any appreciable magnitude. The main parameters affecting tire/pavement drainage

capability are listed in figure 1. The contact pressure developed between tire tread and pavement establishes the escape velocity of bulk water drainage from beneath the footprint. In other words, high inflation pressure tires can drain surface water more readily from the footprint than low inflation pressure tires due to higher water escape velocities. When the aircraft ground speed equals or exceeds the escape velocity of water draining from the footprint, choked flow occurs where water is entering the footprint as fast as it is draining out. The tire is now in the state of total dynamic hydroplaning discussed earlier. Research (refs. 7, 20) shows that the critical aircraft ground speeds ( $V_p$ ) required for this total hydroplaning condition to occur on flooded pavements are approximately (where tire tread depth is less than runway water depth)

$$\text{(unbraked rolling tire)} \quad V_p \approx 9 \sqrt{p} \quad (1)$$

$$\text{(unbraked nonrotating tire)} \quad V_p \approx 7.7 \sqrt{p} \quad (2)$$

where  $V_p$  tire hydroplaning speed, knots

$p$  tire inflation pressure, lb/in.<sup>2</sup>

The rise of dynamic water pressure with increasing ground speed (speed ratio) shown in figure 3(b) thus suggests that flow of draining water from the footprint becomes progressively choked as aircraft ground speed increases (ref. 9). In similar fashion, the tire must squeeze the residual thin viscous water film remaining on the pavement (after bulk water removal) from the footprint or viscous water pressures (ref. 9) will propagate with increasing ground speed as shown in figure 3(b). It should be noted that the water pressure variations with speed depicted in figure 3(b) were obtained under the worst possible tire/pavement drainage conditions (smooth tire tread-smooth pavement), and thus reflect the maximum pressures that can be developed in a tire/pavement contact zone.

Research (refs. 6, 9, 21) shows that bulk water (flooded runway) drainage and alleviation of dynamic water pressures in the tire/ground contact zone are controlled by the runway surface macrotexture (ref. 20) and tire tread groove design. This research also points out that the pavement must be provided with a suitable microtexture (ref. 20) to puncture and drain the viscous water film from the tire/pavement interfaces that creates viscous water pressures beneath the tire footprint. Some additional thin film water drainage is provided by tire tread designs at the contact points between pavement surface and tread rib or tread sipe (automobile tires only) edges. At these points, intense contact pressures are generated which can puncture and displace the water film in the same manner as the pavement surface microtexture.

From this discussion it is apparent that a pavement surface must possess both macrotexture and microtexture to facilitate relief of water trapped in the tire/pavement contact zone and reduce aircraft tire traction losses occurring during wet runway operations. The grooved and porous pavement surface treatments shown in figure 3 are excellent examples of how such texture features can be incorporated into pavement surfaces.

Available tire/ground friction coefficient.- Figure 1 shows that the water depths present on runways during rainstorms interact with tire/pavement drainage capability to establish the friction coefficients available at the tire/pavement interface for aircraft stopping and directional control purposes. Examples of this interaction are shown in figure 4(a) for two pavements and two tire tread patterns tested under a wet and puddled runway condition (ref. 16). In this figure, the braking traction obtained by smooth and five-groove rib tread tires operating on smooth and grooved concrete pavements at ground speeds up to 140 knots are compared. It can be seen that the conventional ungrooved concrete pavement has a low surface macrotexture, average texture depth (A.T.D. = 0.008 inch), in comparison to the same pavement grooved (A.T.D. = 0.067 inch). The result is poor bulk water drainage at high ground speeds for this ungrooved surface and a large reduction in braking traction when compared with the better draining grooved pavement. It was shown in figure 3 that dynamic water pressures build up with the square of ground speed. At low ground speeds, the dynamic water pressures are nonexistent or low in comparison to the viscous water pressure developed in this speed range. This result suggests that grooving the pavement also improved the concrete surface microtexture and greatly alleviated viscous water pressure development under the tire footprint as evidenced by the high braking traction developed by the smooth and five-groove tires on this wet (no standing water) and puddled surface at low speeds. Figure 4(a) also shows that tire tread designs can improve tire/pavement drainage and reduce braking traction losses to some extent, but are not as effective in this regard as improving the pavement surface micro/macro texture by pavement grooving. Research (ref. 10) further indicates that tread designs tend to lose their drainage capability when the tread is approximately 80 percent worn. This discussion suggests that more significant and longer lasting reductions in aircraft tire traction losses on wet runways will occur by improving the pavement surface texture rather than by improving the tire tread design.

Antiskid efficiency.- The basic objectives of aircraft antiskid braking systems are to prevent the wheel brakes from locking the aircraft wheels during initial pilot brake application; and to maximize aircraft stopping and directional control performance (obtained from the main landing gear tires) after pilot brake application, by controlling wheel skidding on runway surfaces such that maximum tire/pavement friction and minimum tire wear are maintained during the braking stop for all runway slipperiness conditions. Precise control of braked wheel motion is easily accomplished by the more modern antiskid systems as long as braking traction levels are high enough to produce reasonable wheel spinup accelerations. This preciseness of braked wheel control by the antiskid deteriorates when braking traction and wheel spinup accelerations are reduced by hydroplaning effects to low or nonexistent levels. The result is a loss of antiskid braking efficiency as shown in figure 4(b) (ref. 18). Under very slippery pavement conditions, the antiskid thus may develop only a small fraction of the friction coefficient available at the tire/pavement interface, and this effect further degrades aircraft stopping and directional control performance during these slippery runway conditions. This discussion emphasizes the need for providing runway surfaces with adequate micro/macro textures so that tire/pavement friction losses are held to a minimum during wet runway operations and the antiskid braking system can then operate at maximum efficiency.

Anomalous antiskid operation.- Figure 5 summarizes the results of a recent unpublished NASA adverse weather hazard analysis of present aircraft braking systems. This analysis shows that present antiskid systems are very forgiving as long as friction levels at the tire/pavement interface are reasonably high (reasonable wheel spinup accelerations available for skid control). Under these conditions, the antiskid has no problem adjusting to early/late spoiler deployment, and early/late and/or soft/hard pilot brake application at landing touchdown. This situation changes when tire braking traction is reduced to low levels by hydroplaning effects at high speeds on wet or slippery runways. Under high speed-slippery runway conditions, three types of anomalous antiskid behavior have been identified as shown in figure 5. All of these anomalies arise as a result of a loss or lack of an adequate aircraft ground speed reference in the antiskid touchdown, skid control, and locked-wheel protection logic circuits.

Braked wheel ratcheting.- This type of abnormal antiskid performance arises because the skid control logic circuits of the antiskid acquire an erroneous indication of the true aircraft ground speed on the runway. For example, the top sketch of figure 6 illustrates a braked-wheel ratcheting case induced by the pilot applying brakes before the wheel had fully spun up after touchdown. Under the same wet runway conditions, the lower sketch of figure 6 shows that the antiskid achieved proper control of braked-wheel motion when the pilot delayed brake application until after the wheel had fully spun up at touchdown. In the former condition, the skid control logic circuit computed the aircraft ground speed to be 50 knots when in reality, the ground speed was closer to 150 knots. As a result, the skid control logic controlled wheel motion at a large slip ratio (70-50 percent). Such anomalous high slip ratio operation of the skid control results in loss of tire braking and cornering capability as shown in figure 7. The loss in stopping performance due to this antiskid anomaly is not indicated in figure 6 because the two test runs shown were made at different conditions of aircraft gross weight and brake application speed, 306,600 lb and 151 knots for the early brake application curve, and 348,600 lb and 157 knots for the lower curve. Control at this high slip ratio continued until approximately 28 seconds after touchdown. At this time, the aircraft ground speed slowed sufficiently to raise the available friction coefficient at the tire/pavement interface enough to produce an over-powering wheel spinup acceleration (after brake release) to cause the wheel to exceed the initial erroneous ground speed reference and acquire a higher one. After several cycles of such behavior, the skid control logic finally acquired the proper ground speed reference and satisfactory control of braked-wheel motion was then established from that point down to a stop.

The fact that the skid control logic finally recovered precise control of braked-wheel motion at a lower ground speed during this run (figure 6) suggests that a limiting low value of friction at the tire/pavement interface exists, below which abnormal antiskid operation can occur, and above which normal antiskid behavior takes place.

The data in figure 6 also suggest that the pilot should delay brake application during wet runway landings to allow sufficient time for the landing gear wheels to fully spinup at touchdown and allow the antiskid to start operation in its most efficient mode (wheels at runway synchronous speed).



Loss of touchdown and locked-wheel protection.- Most antiskid systems have touchdown and locked-wheel protection circuits to prevent brake pressure from being applied to a non-rotating wheel as at landing touchdown or as the result of a braking skid improperly controlled by the antiskid control logic circuit. If these circuits fail to detect the locked-wheel condition, full brake pressure can be applied to the wheel and a prolonged skid will occur. The result on dry runways can be "blown" tires. On wet runways, the result can be the extremely dangerous "reverted rubber" skid where tire cornering capability drops to zero and the braking traction realized by the aircraft is little more than the unbraked rolling resistance of the tire. This type of braking traction loss is illustrated in figure 8 (ref. 22). Loss of touchdown protection can occur on flooded runways (see figure 2) where the wheels will not spinup at or after touchdown because of hydroplaning. Most antiskid touchdown protection circuits allow 2-5 seconds after main landing gear impact on the runway for the wheels to spinup. If the wheels have not spun up during this time period, the pilot can apply brakes and cause a reverted rubber skid because full system pressure is applied to the wheel brakes. Many antiskid systems use the paired wheel concept for locked-wheel protection. With this concept, the speeds of the paired wheels are compared. When the "slow wheel" speed of a system pair drops below a threshold value of slow/fast wheel speed ratio, pressure is removed from the slow wheel brake until the wheel recovers speed equal to or exceeding the threshold value. The problem is that under slippery runway conditions, both wheels in the system pair may be slow (below aircraft reference ground speed), and the oncoming locked-wheel skid is not detected. One solution to this problem is to furnish the locked-wheel protection circuit with an accurate ground speed reference obtained other than from braked-wheel speed sensors, such as the unbraked nose wheel, or from the aircraft inertial guidance system.

Crosswind operations.- The effects of crosswinds on aircraft braking and directional control performance during wet runway operations are not well understood. The main reason for this state of affairs is the difficulty in acquiring quantitative data. A flight test program devised to explore the limits of aircraft crosswind performance under slippery runway conditions results in placing the safety of both aircraft and flight crew in jeopardy. Consideration of tire mechanical properties suggest that strong crosswinds can create an antiskid control dilemma during aircraft braking on slippery runways as shown in figure 7. During combined aircraft braked and yawed rolling, the braking traction coefficient peak decreases in magnitude and shifts to higher slip ratios as yaw angle increases. This result suggests the antiskid must control wheel motion at increasing wheel slip ratio as the aircraft yaws in order to maximize aircraft stopping performance. On the other hand, maintenance of maximum tire cornering capability for aircraft directional control (see figure 7) requires the antiskid to control wheel motion at low slip ratios. What this means in practical terms is that skid controls using velocity rate detection logic will tend to maximize braking at the expense of cornering during high aircraft yaw angle operation. On the other hand, skid controls using slip velocity detection logic will tend to maximize cornering at the expense of braking during high aircraft yaw-angle operation. Only at low aircraft yaw angles do the aircraft tire requirements merge so that antiskid controls can perform an effective job of preserving both tire braking and cornering capability for aircraft stopping and directional performance. Low aircraft yaw attitudes during crosswind operations require

high friction coefficient capability at the tire/pavement interface. This requirement emphasizes the need for providing runway surfaces with adequate micro/macro texture so that tire traction losses during wet runway operation are held to a minimum.

Many researchers share the opinion that motion-based flight simulators with an adequate simulation of tire/pavement forces developed on dry and wet runways is the most promising technique to study aircraft stopping and directional control problems under slippery runway-crosswind conditions. For this reason, the feasibility of building such flight/landing simulators is presently under study.

Rating wet runway slipperiness.- Aeronautical authorities have long realized that the key to solving aircraft stopping and directional control problems on wet runways lies in finding means to measure runway slipperiness with accuracy and in terms that are relatable to aircraft performance. For this reason, research has been undertaken in the United States and Europe for many years to develop such a measuring technique. In 1967, NASA developed a ground vehicle (DBV) diagonal-braking technique which after several years of comprehensive evaluation appears suitable for this purpose. This measuring technique is described in figure 9. The latest experimental aircraft/DBV relationships determined from flight tests (ref. 22) are also shown in figure 9 (lower sketch).

It is important to note that a nearly linear DBV SDR (wet/dry stopping distance ratio) relationship with aircraft stopping distance ratio (SDR) can be obtained for any jet transport as long as the aircraft antiskid braking system operates in a normal manner. This relationship is destroyed when anomalous antiskid behavior takes place (loss of locked-wheel protection), and reverted rubber skidding is developed by the aircraft tires. The reason for this result is obvious in light of the data shown in figure 8. Observations have indicated that low inflation pressure automobile tires do not develop reverted rubber conditions during diagonal braking tests on wet runways. The DBV therefore develops a traction loss with increasing ground speed on the wet runway that is analagous to the aircraft tire  $\mu_{skid}$  curve in figure 8, but not to the aircraft tire reverted rubber curve in this figure. It should be noted that a normally operating antiskid braking system will develop an effective braking traction coefficient that usually lies between the tire  $\mu_{skid}$  and  $\mu_{max}$  boundary curves of figure 8 and therefore will also be analagous to the DBV tire performance.

This discussion suggests that the DBV may be used to measure runway slipperiness with good confidence that the results will be indicative of aircraft stopping performance under a similar runway wetness condition, providing the aircraft antiskid braking system does not develop anomalous behavior.

Flooded runway operation.- Landing aircraft on flooded runways can be extremely hazardous, especially if crosswinds are present. Most aircraft touchdown speeds are in excess of the tire hydroplaning speed. Pilots must exercise caution with regard to brake application during the dangerous period when the aircraft ground speed is above the tire hydroplaning speed or anomalous antiskid behavior can be initiated. The best procedure, if runway

length permits, is for the pilot to initiate reverse thrust as quickly as possible after touchdown, the maximum possible that can be utilized without causing loss of directional control, so that the aircraft can rapidly decelerate through this dangerous speed regime. The pilot initiates braking when the aircraft ground speed descends below tire hydroplaning speed. Using this technique, landing on long flooded runways should not be difficult as long as crosswinds are low. Landings on flooded short or critical field length runways under crosswind or tailwind conditions, and on flooded long runways when crosswinds are high, should be avoided or approached with caution. In these simulations the risk is great that the aircraft may not stop before overrunning or departing the side of the flooded runway.

#### SUGGESTIONS FOR IMPROVING AIRCRAFT WET RUNWAY PERFORMANCE

The preceding sections of this paper have reviewed some important parameters associated with aircraft stopping and directional control performance on wet runways. As a result of this review, new information and technology have been exposed which can be used to improve aircraft wet runway performance. Several suggestions in this regard are listed in figure 10 and are discussed in detail in the following paragraphs:

Identify flooded runway condition to pilot before landing.- Aircraft skidding accident investigations point out that some pilots have landed aircraft on flooded runways and then hydroplaned off the side or end (refs. 23, 24). To avoid such accidents, pilots need information concerning the hydroplaning potential of the runway before the landing is attempted. Curves such as shown in figure 2 could be constructed for operational runways. These curves, along with recording rain gages sited near each runway to provide readout capability at the tower, could supply sufficient information to inform pilots about the runway dynamic hydroplaning potential before a landing is attempted.

Identify slippery runways for aircraft operation.- Aircraft skidding accident investigations and instrumented ground vehicle/aircraft wet runway tests have shown that some operational runways, and rubber coated landing touchdown areas of the runways can become excessively slippery when wet for safe aircraft operations. Current ground vehicle runway slipperiness measuring techniques can be used to identify such slippery runway or runway areas. Operational runways that are slippery when wet need to be identified, and the runway surface slipperiness problem corrected by the use of proven techniques such as rubber removal, pavement grooving, or porous asphalt overlays.

Modify present landing procedures.- This paper indicates that pilots can induce anomalous performance of some present aircraft antiskid braking systems under slippery runway conditions by early and hard application of brakes after landing touchdown, and thereby further degrade aircraft stopping and directional control performance on the slippery runway. Pilots should be informed of the need to use reverse thrust effectively so that the aircraft can rapidly decelerate through the hazardous speed regime where the aircraft

ground speed lies above the tire hydroplaning speed. Pilots must apply brakes with caution in this speed regime or anomalous antiskid braking performance may occur.

Improve antiskid system locked-wheel protection circuit.- The most catastrophic loss of aircraft stopping and directional control performance on wet runways occurs when the landing gear wheels lock-up and "reverted rubber" skidding is developed by aircraft tires. This paper illustrates that some present antiskid locked-wheel protection circuits can become ineffective under certain slippery runway conditions and fail to prevent locked-wheel operation from occurring. This situation can be alleviated and remedied by improving locked-wheel protection logic circuits through use of optimized wheel pairing and provision of a true ground speed reference.

Develop aircraft flight/landing simulators.- Present technology is such that aircraft directional control problems cannot be fully explored for even the least hazardous combinations of runway slipperiness and wind. For this reason, a great need exists to expand present flight simulator capability to include simulation of tire/pavement forces generated under slippery runway/crosswind conditions.

Certification of aircraft landing performance on wet runways.- At the present time all civil jet transport aircraft in the United States are certificated for landing performance on dry runways. The data trends reported in this paper suggest that aircraft landing performance should be certificated under wet runway conditions. For example, this paper describes the locked-wheel "reverted rubber" skid as catastrophic to aircraft braking and directional control performance on wet runways when it develops. Many aircraft skidding accidents/incidents that have occurred to the present jet transport fleet on wet runways show evidence that this phenomenon developed during the landings (ref. 12). This paper shows that this phenomenon can result from anomalous behavior of the aircraft antiskid system on slippery runways at high speed along with a failure of the antiskid locked-wheel protection circuits to detect locked-wheel conditions on the aircraft tires. Anomalous behavior of the antiskid system has not been observed to develop during landings on high friction dry runways. Therefore, wet runway certification landings, preferably made on rubber-coated runway touchdown areas, are needed to demonstrate that the aircraft braking system can operate safely under high speed-slippery runway touchdown conditions.

#### CONCLUDING REMARKS

Some important parameters affecting aircraft stopping and directional control performance on wet runways have been reviewed. This review indicates that the past 17 years of wet runway research has been extremely productive, and has generated many new concepts for combating aircraft operating problems on wet runways. It is felt that time is now ripe for the implementation of this research and suggestions are made in this regard.

## REFERENCES

1. Harrin, Eziaslav N.: Low Tire Friction and Cornering Forces on a Wet Surface. NACA TN 4406, 1958.
2. Sawyer, Richard H.; Batterson, Sidney A.; and Harrin, Eziaslav N.: Tire-to-Surface Friction Especially Under Wet Conditions. NASA Memo 2-23-59L, 1959.
3. Horne, Walter B.; Joyner, Upshur T.; and Leland, Trafford J. W.: Studies of the Retardation Force Developed on an Aircraft Tire Rolling in Slush or Water. NASA TN D-552, 1960.
4. Harrin, Eziaslav N.: Investigation of Tandem-Wheel and Air-Jet Arrangements for Improving Braking Friction on Wet Surfaces. NASA TN D-405, 1960.
5. Anon.: Joint Technical Conference on Slush Drag and Braking Problems. FAA and NASA, Dec. 1961.
6. Horne, Walter B.; and Leland, Trafford J. W.: Influence of Tire Tread Pattern and Runway Surface Condition on Braking Friction and Rolling Resistance of a Modern Aircraft Tire. NASA TN D-1376, 1962.
7. Horne, Walter B.; and Dreher, Robert C.: Phenomena of Pneumatic Tire Hydroplaning. NASA TN D-2056, 1963.
8. Joyner, Upshur T.; Horne, Walter B.; and Leland, Trafford J. W.: Investigations on the Ground Performance of Aircraft Relating to Wet Runway Braking and Slush Drag. AGARD Rept. 429, Jan. 1963.
9. Horne, Walter B.; and Joyner, Upshur T.: Pneumatic Tire Hydroplaning and Some Effects on Vehicle Performance. SAE International Automotive Engineering Congress (Detroit, Michigan), SAE 970C, January 11-15, 1965.
10. Leland, Trafford J. W.; and Taylor, Glenn R.: An Investigation of the Influence of Aircraft Tire-Tread Wear on Wet-Runway Braking. NASA TN D-2770, April 1965.
11. Dreher, Robert C.; and Horne, Walter B.: Ground Run Tests with a Bogie Landing Gear in Water and Slush. NASA TN D-3515, 1966.
12. Horne, Walter B.: Skidding Accidents on Runways and Highways Can Be Reduced. Astronautics and Aeronautics, vol. 5, no. 8, Aug. 1967, pp. 48-55.
13. Horne, Walter B.; Yager, Thomas J.; and Taylor, Glenn R.: Review of Causes and Alleviation of Low Tire Traction on Wet Runways. NASA TN D-4406, 1968.
14. Leland, Trafford J. W.; Yager, Thomas J.; and Joyner, Upshur T.: Effects of Pavement Texture on Wet-Runway Braking Performance. NASA TN D-4323, January 1968.

15. Lander, F. T. W.; and Williams, T.: The Skidding Resistance of Wet Runway Surfaces with Reference to Surface Texture and Tyre Conditions. Road Research Laboratory Rept. 184, 1968.
16. Anon.: Pavement Grooving and Traction Studies. NASA SP-5073, 1969.
17. Yager, Thomas J.; Phillips, W. Pelham; Horne, Walter B.; and Sparks, Howard C. (Aeronautical Systems Div., WPAFB): A Comparison of Aircraft and Ground Vehicle Stopping Performance on Dry, Wet, Flooded, Slush-, and Ice-Covered Runways. NASA TN D-6098, Nov. 1970.
18. Preston, O. W.; Kibbee, G. W.; Muroyama, R. H.; and Storley, R. A. (McDonnell-Douglas Aircraft Company): Development of a Basic Methodology for Predicting Aircraft Stopping Distance on a Wet Runway. Prepared for Federal Aviation Administration. Report No. FAA-RD-70-62, March 1971.
19. Galloway, R. M.; Schiller, Jr., R. E.; and Rose, Jerry G.: The Effect of Rainfall Intensity, Pavement Cross Slope, Surface Texture, and Drainage Path Length on Pavement Water Depths. Texas Transportation Institute, Texas A & M University, Research Report No. 138-5. Vehicle-Pavement Interaction Research Study No. 2-8-69-138, May 1971.
20. Anon.: Frictional and Retardation Forces on Aircraft Tyres. Part I: Introduction. Royal Aeronautical Society Engineering Sciences Data Item No. 71025 (with amendment A). August 1972.
21. Horne, Walter B.: Elements Affecting Runway Traction. Presented at Annual SAE Air Transportation Meeting, Dallas, TX, April 30-May 2, 1974. SAE Paper 740496.
22. Merritt, Leslie R.: Concorde Landing Requirement Evaluation Tests. Report FAA-FS-160-74-2, August 1974.
23. Anon.: Aircraft Accident Report. Caribbean Atlantic Airlines, Inc, Douglas DC-9-31, N938PR. Harry S. Truman Airport, Charlotte Amalie, St. Thomas, Virgin Islands, August 12, 1969. NTSB Report No. NTSB-AAR-70-23.
24. Anon.: Aircraft Accident Report. Piedmont Airlines, Boeing 737, N751N, Greensboro, NC, October 28, 1973. NTSB Report No. NTSB-AAR-74-7.

FIGURE 1.- FACTORS AFFECTING AIRCRAFT WET RUNWAY PERFORMANCE

PRECEDING PAGE BLANK NOT FILMED

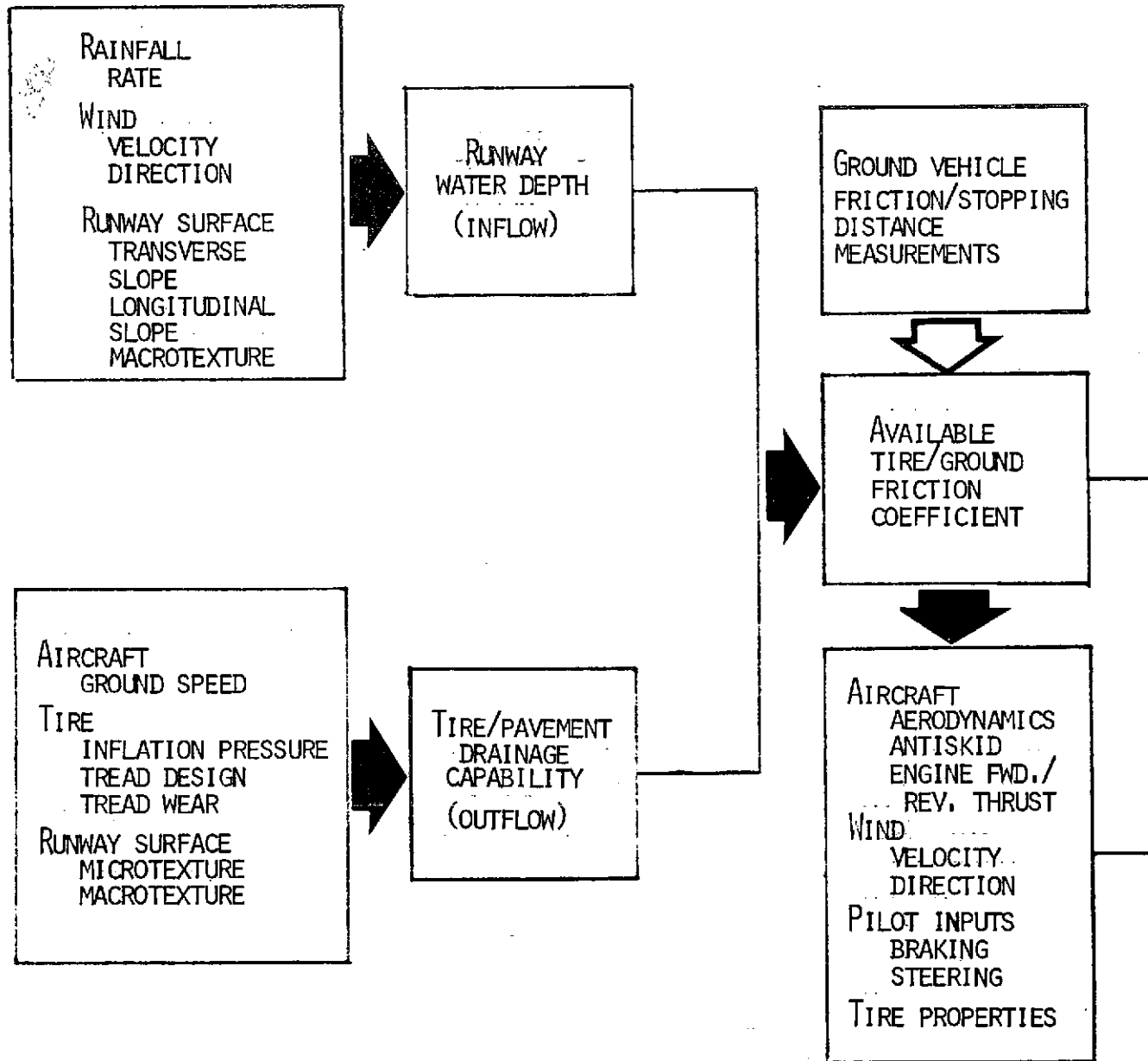

FIGURE 2.- RUNWAY HYDROPLANING POTENTIAL DURING RAINSTORMS

TRANSVERSE CROWN = 1%; WHEEL TRACK 12.8 FT (FROM CENTERLINE)  
TTI DATA (REF. 19) MODIFIED FOR HEAD WINDS

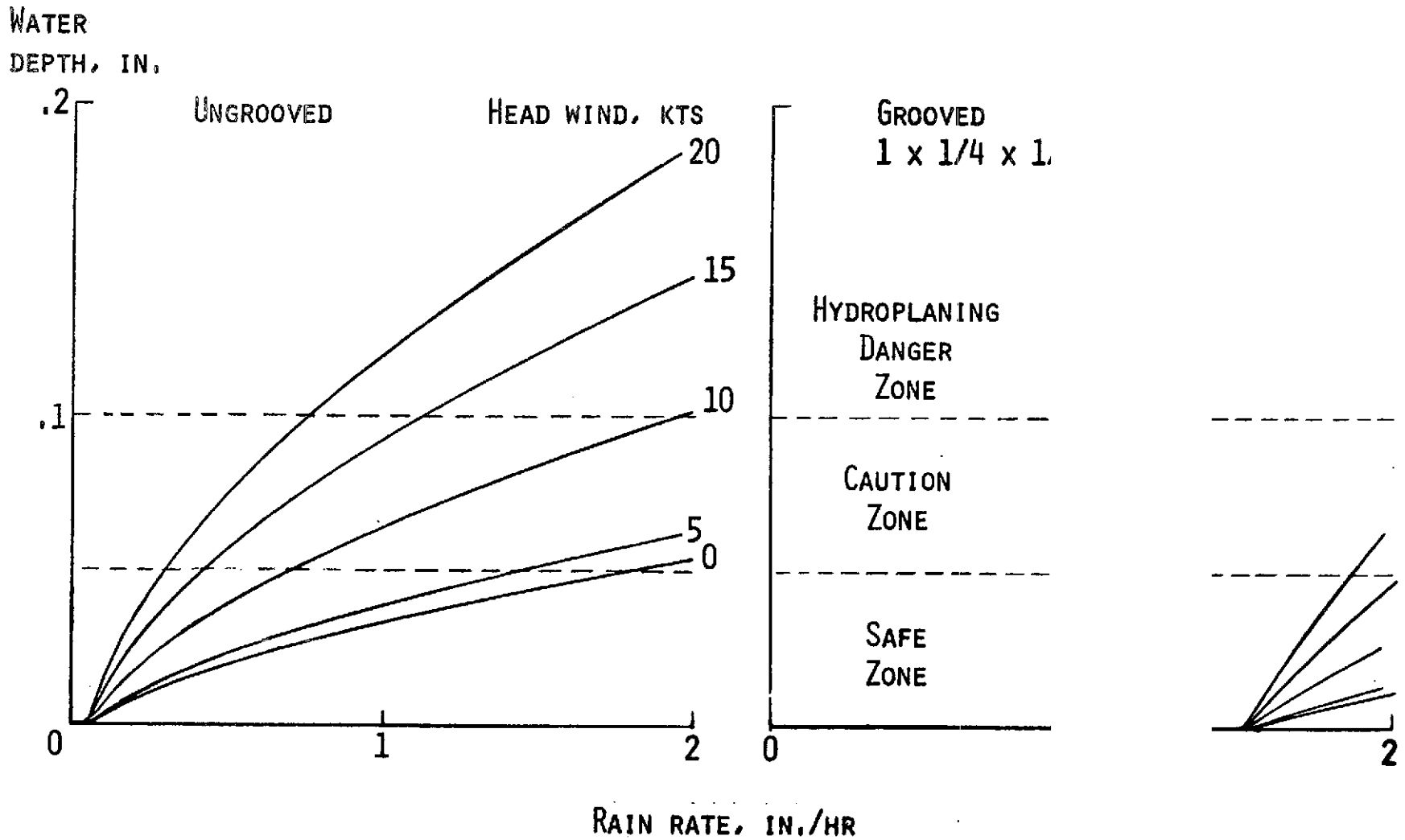



FIGURE 3.- TIRE / PAVEMENT DRAINAGE CHARACTERISTICS

(A) PAVEMENT SURFACE TEXTURE EFFECTS ON DRAINAGE  
(REF. 19)

PAVEMENT	TEXTURE		FLUID PRESSURE ALLEVIATION	
	MICRO	MACRO	VISCOUS	DYNAMIC
SMOOTH	LOW	LOW	POOR	POOR
SMOOTH STONES	LOW	MEDIUM	POOR	GOOD
SAND-PAPERY	HIGH	LOW	EXCELLENT	POOR
FRACTURED STONES	HIGH	MEDIUM	EXCELLENT	GOOD
GROOVES	LOW	HIGH	FAIR	EXCELLENT
GROOVES	HIGH	HIGH	EXCELLENT	EXCELLENT
POROUS	MEDIUM	HIGH	GOOD	EXCELLENT

(B) FLUID PRESSURE DEVELOPMENT WITH SPEED  
IN TIRE/ GROUND CONTACT PATCH  
(REF. 9)

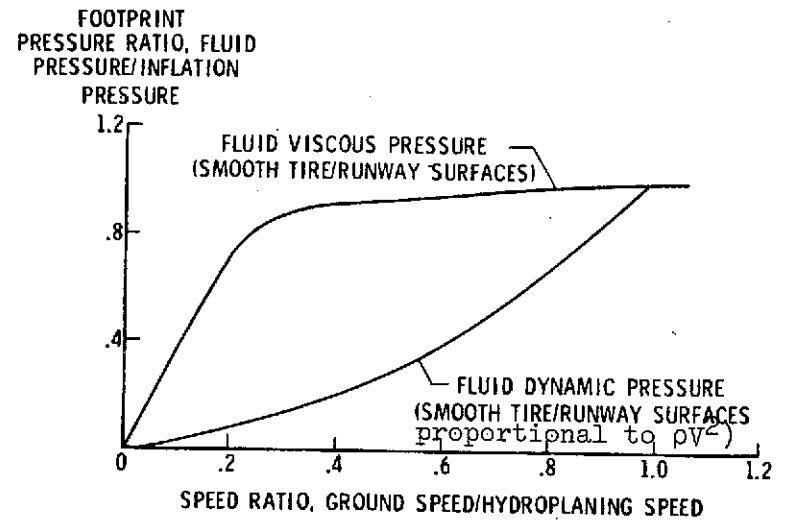
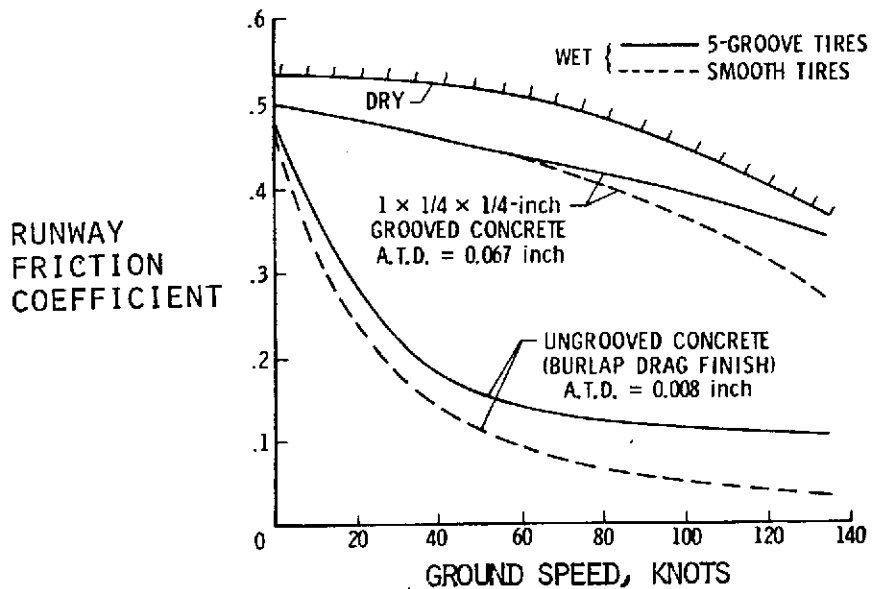

FIGURE 4.- WET RUNWAY EFFECTS ON TIRE / AIRCRAFT BRAKING TRACTION

(A) BRAKING TRACTION AVAILABLE AT TIRE/PAVEMENT INTERFACE



(REF. 16)

(B) BRAKING TRACTION AVAILABLE FOR AIRCRAFT REDUCED BY ANTISKID EFFICIENCY

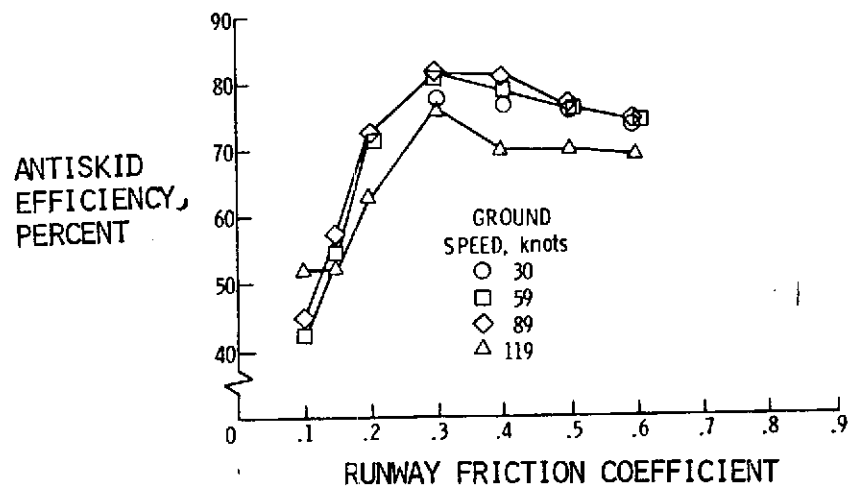

(REF. 18)

FIGURE 5. - SUMMARY OF ANALYSIS OF PRESENT  
AIRCRAFT ANTISKID BRAKING SYSTEMS

- EXPECT NORMAL ANTISKID OPERATION
  - High Wheel Spinup Accelerations
    - High to Medium Runway Traction
    - Early Spoiler Deployment at Touchdown
  - Pilot Brake Application After Wheel Spinup (Touchdown)
  
- EXPECT ABNORMAL ANTISKID OPERATION
  - Low to Nil Wheel Spinup Accelerations
    - Low to Nil Runway Traction Conditions
    - Delayed Spoiler Deployment at Touchdown
  - Pilot Brake Application Before Wheel Spinup (Touchdown)
  
- TYPICAL ANTISKID OPERATIONAL ANOMALIES
  - Loss of Touchdown Protection
  - Braked Wheel Ratcheting
  - Loss of Locked - Wheel Protection }      Loss or Lack of  
Adequate Ground  
Speed Reference

FIGURE 6. - PILOT BRAKING TECHNIQUE - ANTISKID PERFORMANCE  
WET SLIPPERY RUNWAYS

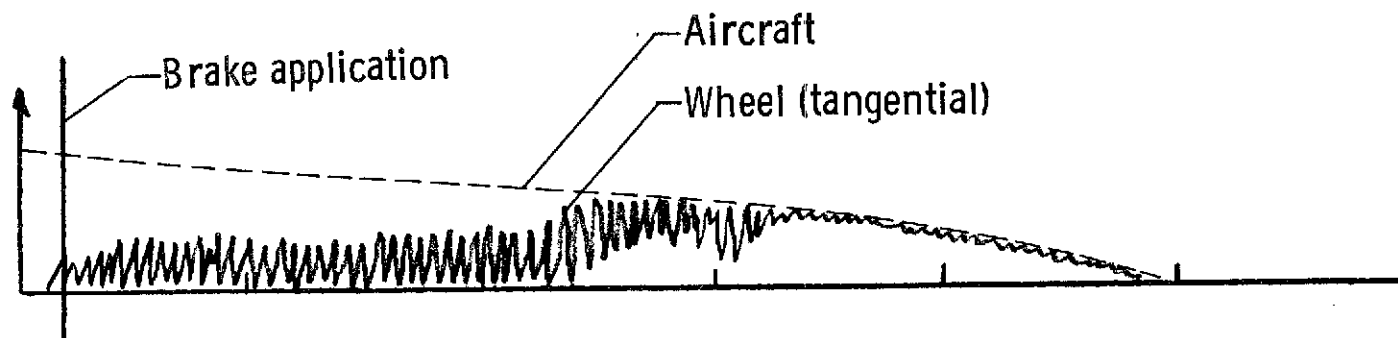

SPEED

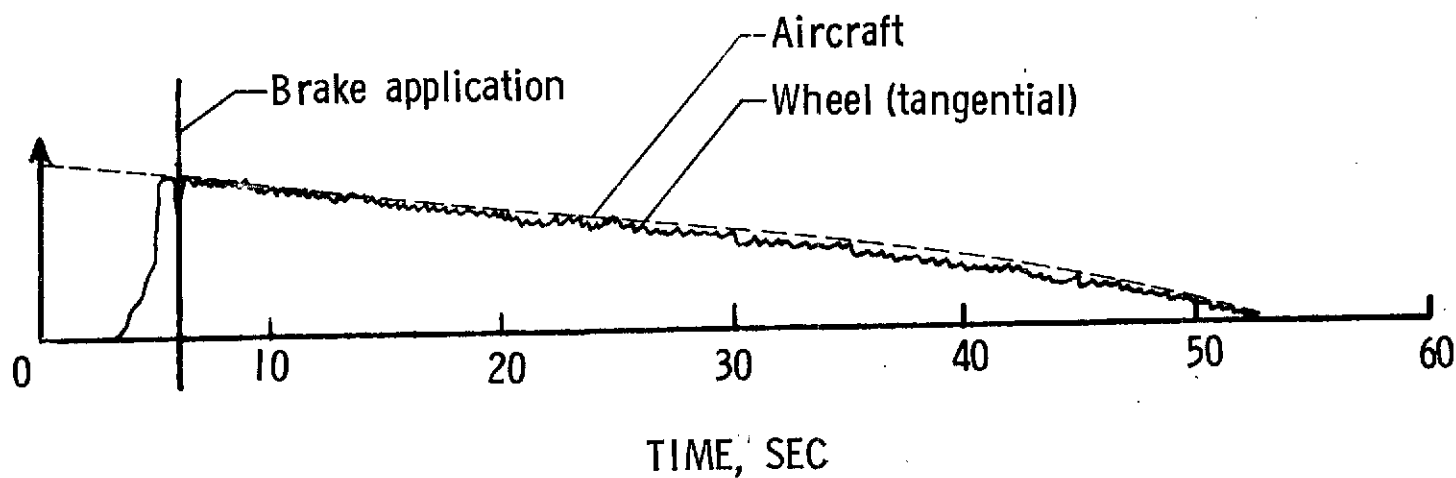
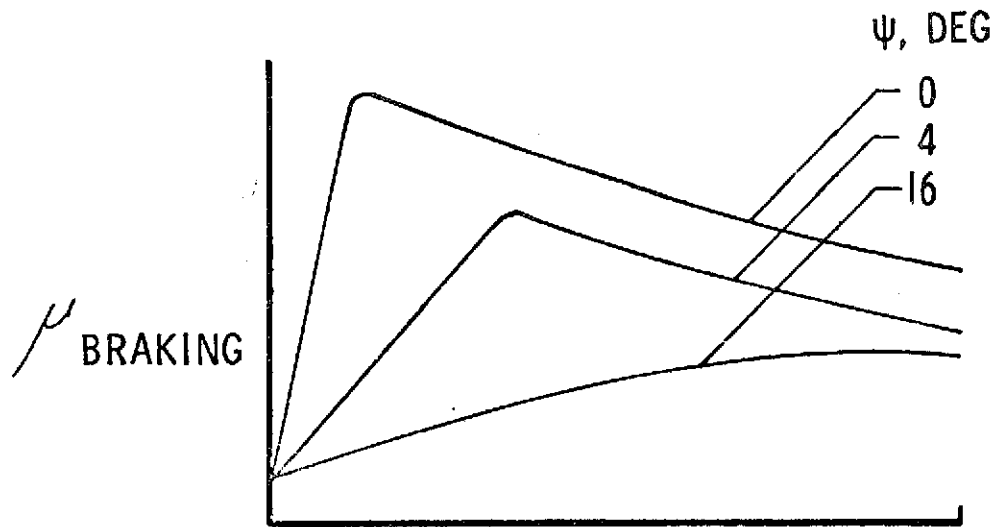
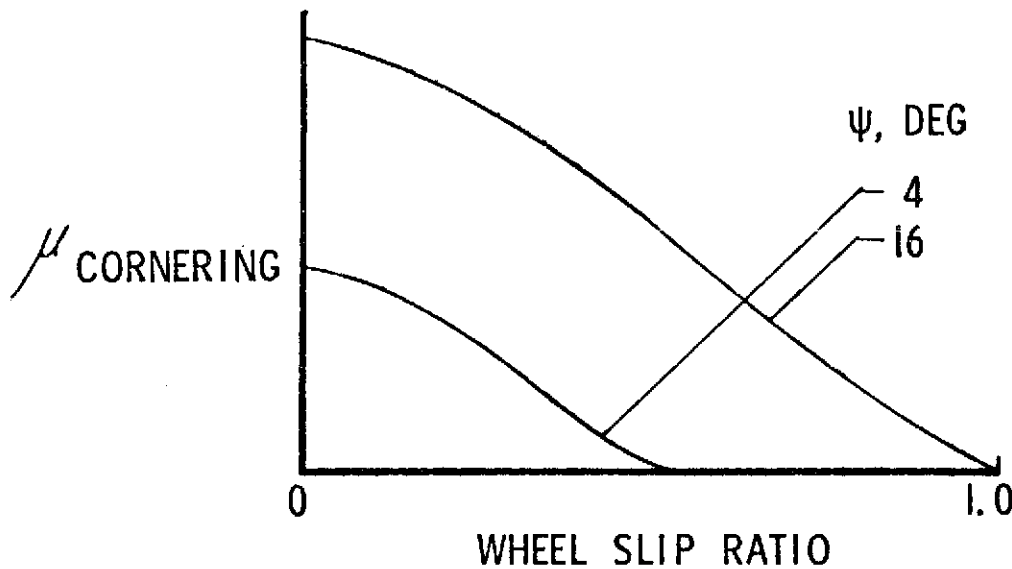

FIGURE 7.- CONFLICTING TIRE BRAKING AND CORNERING CHARACTERISTICS CREATES ANTISKID CONTROL DILEMMA DURING CROSSWIND OPERATIONS



TO PRESERVE BRAKING

Antiskid must operate at increasing slip ratio as aircraft yaws



TO PRESERVE CORNERING

Antiskid must operate at low slip ratios

FIGURE 8.- ANTISKID ANOMALY- LOSS OF LOCKED-WHEEL PROTECTION  
(DEVELOPED DURING WET RUNWAY BRAKING TESTS)

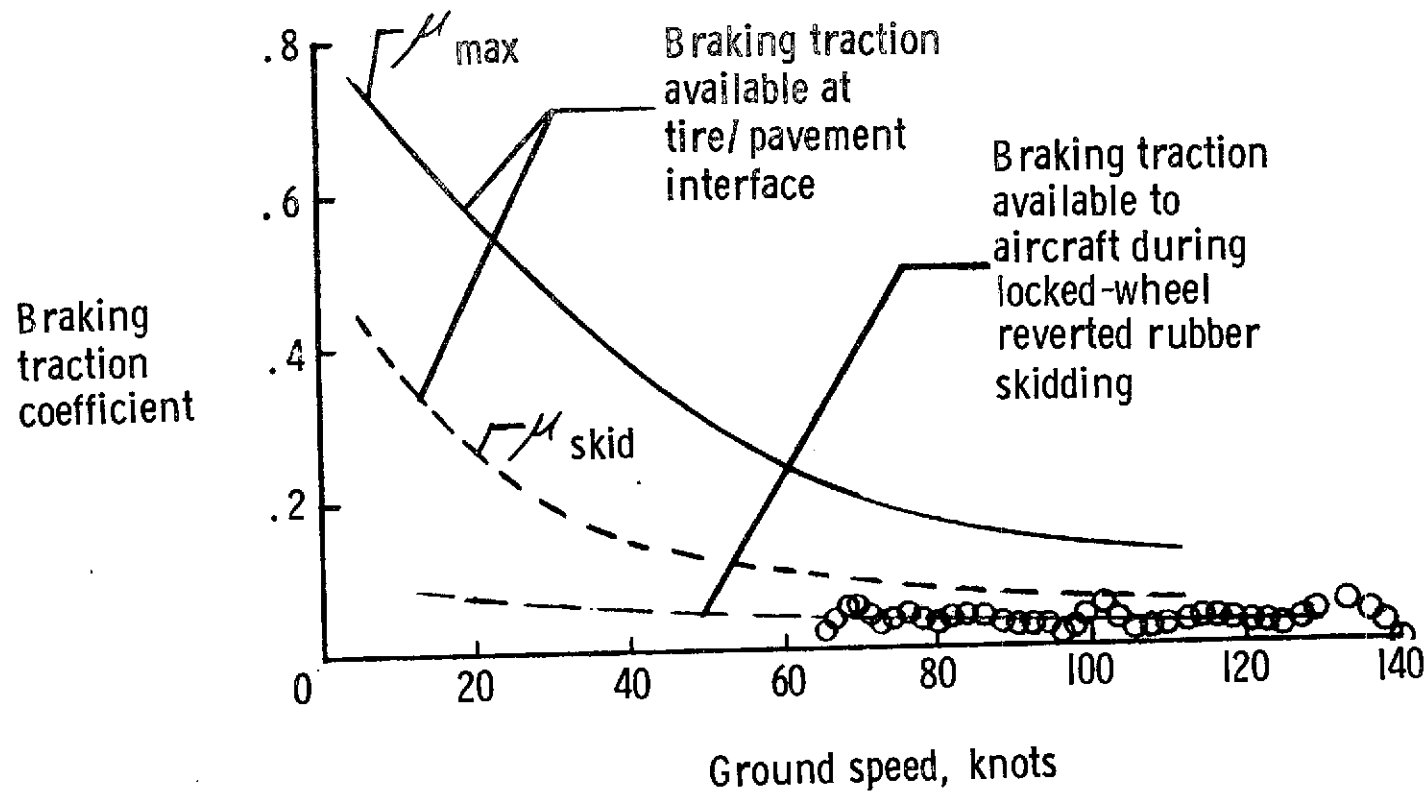

(REF. 22)

FIGURE 9.- AIRCRAFT/GROUND VEHICLE RATING OF WET RUNWAY SLIPPERINESS

NASA DIAGONAL-BRAKED VEHICLE

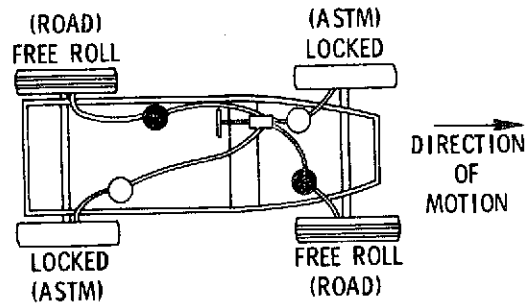

- VALVE CLOSED; BRAKES CANNOT BE ACTUATED
- VALVE OPEN; BRAKES CAN BE ACTUATED

- MEASURES STOPPING DISTANCE FROM 60-0 MPH (DIAGONAL-WHEELS LOCKED)
- WET RUNWAY SLIPPERINESS INDEX

$$SDR = \frac{\text{WET STOPPING DISTANCE}}{\text{DRY STOPPING DISTANCE}}$$

EXPERIMENTAL AIRCRAFT/DBV RELATIONSHIPS

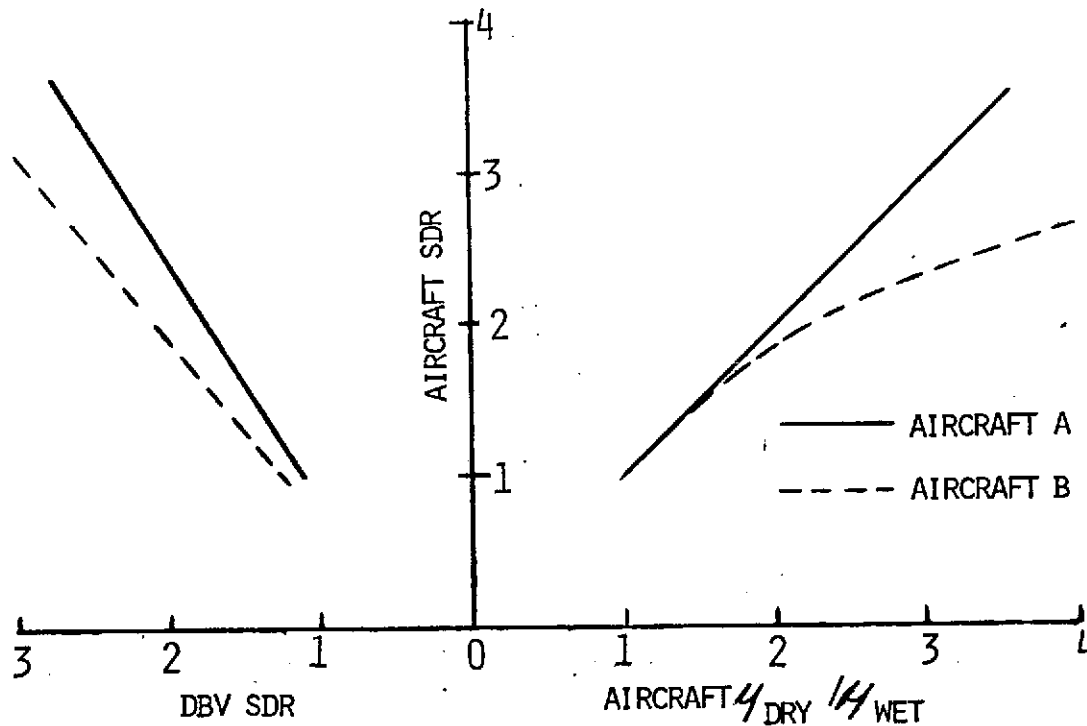

- VALID RELATIONSHIPS OBTAINED
  - NORMAL ANTISKID OPERATION
  - RUNWAY WATER DEPTHS < 0.05 INCH
- INVALID RELATIONSHIPS OBTAINED
  - ABNORMAL ANTISKID OPERATION (LOCKED-WHEEL/REVERTED RUBBER SKIDS)
  - RUNWAY WATER DEPTHS > 0.05 INCH (UNKNOWN DYNAMIC HYDROPLANING EFFECTS)

## FIGURE 10. - SUGGESTIONS FOR IMPROVING AIRCRAFT WET RUNWAY PERFORMANCE

- IDENTIFY FLOODED RUNWAY CONDITION TO PILOT BEFORE LANDING
- IDENTIFY SLIPPERY RUNWAYS FOR AIRCRAFT OPERATION
  - Measurement by Ground Vehicle
  - Remedy by Grooving, Porous Friction Course, or Rubber Removal
- MODIFY PRESENT LANDING PROCEDURES
  - Emphasize Use of Reverse Thrust
  - Importance of Delayed and Gentle Initial Brake Application (After Touchdown)
- IMPROVE PRESENT ANTISKID SYSTEM LOCKED-WHEEL PROTECTION CIRCUITS
  - Optimized Wheel Pairing
  - Provide True Ground Speed Reference
- DEVELOP AIRCRAFT FLIGHT/ LANDING SIMULATOR
  - Define Aircraft/ Runway Crosswind Limitations
  - Optimize Pilot/ Aircraft Landing Techniques
  - Optimize Landing Gear Design
- CERTIFY AIRCRAFT LANDING PERFORMANCE UNDER WET RUNWAY CONDITIONS FOR NEW DESIGNS