

NASA TECHNICAL NOTE

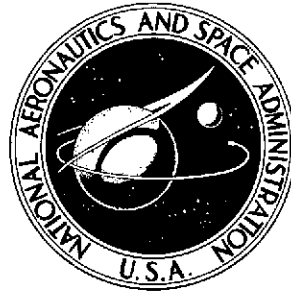

NASA TN D-7954

NASA TN D-7954

(NASA-TN-D-7954) FRICTION TRANSITION IN
POLYIMIDE FILMS AS RELATED TO MOLECULAR
RELAXATIONS AND STRUCTURE (NASA) 30 p HC
\$3.75

N75-20563

CSCL 07D

Unclass

H1/27 18686

FRICTION TRANSITION IN POLYIMIDE FILMS AS RELATED TO MOLECULAR RELAXATIONS AND STRUCTURE

Robert L. Fusaro

Lewis Research Center

Cleveland, Ohio 44135

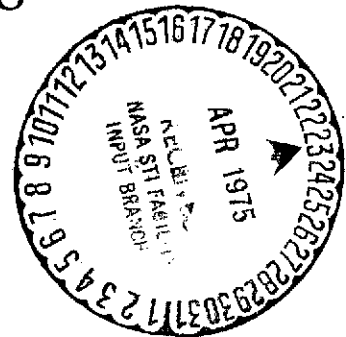

1. Report No. NASA TN D-7954	2. Government Accession No.	3. Recipient's Catalog No.	
4. Title and Subtitle FRICION TRANSITION IN POLYIMIDE FILMS AS RELATED TO MOLECULAR RELAXATIONS AND STRUCTURE		5. Report Date April 1975	
		6. Performing Organization Code	
7. Author(s) Robert L. Fusaro		8. Performing Organization Report No. E-8021	
		10. Work Unit No. 505-04	
9. Performing Organization Name and Address Lewis Research Center National Aeronautics and Space Administration Cleveland, Ohio 44135		11. Contract or Grant No.	
		13. Type of Report and Period Covered Technical Note	
12. Sponsoring Agency Name and Address National Aeronautics and Space Administration Washington, D. C. 20546		14. Sponsoring Agency Code	
		15. Supplementary Notes	
16. Abstract <p>The friction characteristics of polyimide films bonded to metallic substrates were studied from 25^o to 500^o C. These results were correlated to molecular structure and the results of torsional braid analysis (TBA). A large friction transition (0.23 to 0.03) was found to occur at 45^o C ± 5^o C. It was postulated that this transition was initiated by some molecular relaxation, which gave the molecules a degree of freedom by which an external mechanical stress could rearrange the molecules into a structure, such as an extended chain, which is conducive to easy shear. Above 300^o C the friction characteristics were found to be dependent on the thermal prehistory of the film.</p>			
17. Key Words (Suggested by Author(s)) Polyimide; Polymer; Molecular relaxations; Torsional braid analysis; Friction transition; Solid lubricant; Bonded film		18. Distribution Statement Unclassified - unlimited STAR category 27 (rev.)	
19. Security Classif. (of this report) Unclassified	20. Security Classif. (of this page) Unclassified	21. No. of Pages 29	22. Price* \$3.75

* For sale by the National Technical Information Service, Springfield, Virginia 22151

FRICITION TRANSITION IN POLYIMIDE FILMS AS RELATED TO MOLECULAR RELAXATIONS AND STRUCTURE

by Robert L. Fusaro

Lewis Research Center

SUMMARY

Friction studies of pyrolin polyimide (PI-4701) films bonded to metallic substrates were conducted. A large friction transition was found to occur at $45^{\circ}\text{C} \pm 5^{\circ}\text{C}$ in a dry argon atmosphere (10 ppm H_2O). Below 45°C , friction was higher than 0.20; above 45°C , friction could be as low as 0.02 to 0.03. The friction transition was found to be reversible when the temperature was raised or lowered through the transition region. Varying the sliding velocity (in the range 1.33 to 0.027 m/sec) did not markedly affect the friction transition temperature, although as velocity was reduced the friction trace usually got "rougher."

The friction results were compared with thermomechanical data obtained on this polyimide by use of the torsional braid analysis (TBA) technique. The comparison indicated that there was a molecular relaxation (movement of some part of the molecule) taking place in the region where the friction transition occurred. It was thus postulated that mechanical stresses, occurring between the sliding surfaces, transform or reorder the polyimide molecules into a structure, such as an extended chain, which is conducive to easy shear. The molecular relaxation which occurs in this temperature region appears to give the molecules the necessary freedom for this reordering process to occur.

Heating the polyimide film (in a dry argon atmosphere) to 500°C increased the glass-transition temperature to a value greater than 500°C . The 500°C cure, however, did not have any great effect on the large friction transition which occurred at $45^{\circ}\text{C} \pm 5^{\circ}\text{C}$; but it did markedly improve the friction properties of the polyimide film at temperatures between 300°C and 500°C .

INTRODUCTION

Technology today is placing ever increasing demands on polymers. Polymers are

needed which have improved mechanical properties at higher temperatures. One new class of thermally stable organic polymers which has demonstrated increased capabilities in these areas is polyimide. It is possible to tailor the mechanical properties of polyimide either by varying its molecular structure or by controlling its thermal prehistory (refs. 1 to 4).

In the field of lubrication, polyimide usage is continually increasing. Solid bodies of polyimide, with or without solid lubricant additives, are being considered for bearings and seals and in prosthetic human joints (refs. 5 to 7). In addition, polyimides have been used to bind solid lubricants to metal surfaces. Pyrolin polyimide (PI-4701) has been shown to be a good binder for the solid lubricant graphite fluoride ($CF_{1.1}$)_n (refs. 8 and 9) and for molybdenum disulfide (ref. 10).

The lubricating properties of polyimide films with no solid lubricant additives were studied in references 9 and 11. These studies revealed that a transition in the friction and wear life properties of polyimide films existed. Above some minimum temperature (between 25^o and 100^o C), the polyimide films exhibited much longer wear lives and considerably lower friction coefficients than they did below this temperature.

This investigation was conducted to determine the friction transition temperature more precisely and to find mechanisms that might be responsible for these transitions. The latter was attempted by comparing the friction properties of polyimide to molecular relaxations that are thermally induced in polyimide and by considering different molecular models of polymer structure. The molecular relaxation data were obtained by a dynamic mechanical technique called torsional braid analysis (TBA) (refs. 2 to 4). These tests were conducted at Princeton University by Dr. J. K. Gillham under NASA purchase order C-60346-C.

BACKGROUND

Molecular Relaxations in Polymers

It is well known that most polymers have a glass-transition temperature T_G which marks their change from a rubbery to a glassy state. It is not so well known that most polymers also have secondary transitions below their T_G (refs. 12 to 24). These secondary transitions appear to be very influential in determining the mechanical properties of polymers (ref. 18). Where and why these transitions occur has thus become the subject of continuing research (refs. 1 to 4, and 12 to 24).

Both the glass transition and the secondary transitions can be related to one or more molecular relaxation processes (changes of motion within polymer chains). The glass transition has been related to the motion of longer segments of the main chain; while the

secondary transitions have been related to rotations or oscillations of side chains, subgroups, chain ends, or short segments of the main chain (refs. 16 to 19).

There are several methods now in use for studying the molecular relaxation phenomena. Among them are nuclear magnetic resonance (rf energy absorption), dielectric energy absorption, and mechanical energy absorption. Essentially, all three methods consist of applying a force to the polymer molecules and then observing the energy absorption peaks that take place at various temperatures. By comparing the position and size of the peaks, it is possible to deduce what type of molecular motion has taken place.

Molecular relaxations tend to be frequency dependent as well as temperature dependent (refs. 16 and 18); that is, the absorption peaks tend to move to higher temperatures as the applied frequency is increased. For this reason, in this investigation, correlation has been made between friction data (taken at relatively low frequencies) and mechanical energy absorption data also taken at low frequencies (~ 1 Hz).

Torsional Braid Analysis

The technique used in this investigation to obtain the mechanical absorption spectra of polyimide was torsional braid analysis (TBA). The method is described in detail in references 2, 3, 4, and 12. A schematic drawing of the apparatus is shown in figure 1 (from ref. 4). The method uses an oscillating torsional pendulum, which consists of a glass braid impregnated with the polymer to be evaluated. Two quantities can be determined by evaluating the mechanical oscillations of the pendulum: the elastic part of the complex shear modulus G' and a quantity called the logarithmic decrement δ , which is a measure of the ratio of the energy dissipated to the maximum energy stored during mechanical deformation. Because of the nature of the specimens used, an absolute value of the elastic modulus G' is difficult to calculate. Since $G' = K(1/p^2)$, a measure of G' can be expressed in terms of $1/p^2$, where K is a constant for a particular specimen and p is the period of oscillation. This quantity $1/p^2$ is defined as the relative rigidity of the polymer (refs. 2, 3, 4, and 12).

Models of Polymer Structure

Polymers may be classified as being either amorphous or crystalline; however, even in well-crystallized polymers, amorphous regions have been found to exist (refs. 25 to 29). Likewise in amorphous polymers, crystalline regions have been observed (refs. 25 to 29). Undoubtedly, the interaction of these regions, as well as the

transformation from one phase to another, can influence the physical properties of a polymer.

In order to explain the various physical properties possessed by polymers, several models of polymer structure have been proposed. Some of the most prominent models are the following:

- (1) Random coil (refs. 29 to 31)
- (2) Fringed micelle (refs. 25 to 27, 30, and 32 to 36)
- (3) Folded chain (refs. 19, 25 to 27, and 36 to 39)
- (4) Extended chain (refs. 40 to 42)
- (5) Molecular domain (ref. 43)

The model that is most widely accepted for crystalline polymers is the folded chain. It is based on the fact that complex aggregates of molecules, called spherulites, exist throughout the entire mass of solid polymers (refs. 25 to 28, 35, and 36). X-ray diffraction studies have shown these spherulites to be composed of platelike lamellae (refs. 19, and 25 to 27). Although the thickness of these lamellae may vary, the lamellae formed for particular crystallization conditions are characterized by a rather uniform thickness, of the order of 5 to 100 nanometers (50 to 1000 Å). Electron microscopy has shown that the lamellae consist of regularly folded chains which are perpendicular to the lamellae surface; thus, this model has been designated the folded-chain model.

Figure 2 gives a schematic representation of a polymer which has been crystallized under different conditions and has attained different degrees of order (ref. 19). Folded chains, extended chains, and the amorphous nature of the polymer can be seen. If the distance between the folds in the folded-chain model becomes greater than 200 nanometers (2000 Å), the crystal is designated as an extended-chain crystal (refs. 40 and 41). When no folds are present, the term fully extended-chain crystal is applied.

There are several ways that extended-chain crystals can form. They can be formed from the melt by regulating crystallization conditions, they can be formed in a polymer solid by annealing it at temperatures above the crystallization temperature, or they can be formed by applying a mechanical stress to a polymer so as to induce chain unfolding (refs. 40 and 41).

Two models for chain unfolding by the mechanical deformation of lamellae have been proposed (refs. 25 and 42). The first proposes that, by plastic deformation, the chains simply unfold in the direction of the applied force. The second proposes that, by shearing deformation, the chains gradually become tilted by twisting and slipping and thus become progressively oriented in the direction of the force.

EXPERIMENTAL PROCEDURE

Friction Apparatus

A hemisphere-on-flat sliding friction apparatus was used to study the polyimide friction transition. The friction specimens (fig. 3) consisted of a flat (6.3 cm diam) disk in sliding contact with a stationary (0.476 cm rad.) hemispherically tipped rider. The wear track diameter on the disk was varied by changing the position of the rider. Thus, several tests could be performed on each disk on diameters that ranged from 3.8 to 5.8 centimeters. The apparatus was equipped with a variable-speed motor and gear reduction system so that the rotational speed could be varied from 10 to 1000 rpm.

Induction heating was used to heat the disk. A strain gage sensed the frictional force, which was continuously recorded on a strip-chart recorder or plotted as a function of temperature on an x-y recorder.

Surface Preparation and Cleaning

The hardness range of the 440C stainless-steel specimens used in this investigation was Rockwell C-58 to C-60. The disk surfaces were roughened by sandblasting to an rms of 0.9×10^{-6} to 1.3×10^{-6} meter (35×10^{-6} to 50×10^{-6} in.). After sandblasting the disks were cleaned by the following procedure:

- (1) The surface was scrubbed under running water with a brush to remove abrasive particles.
- (2) Then it was cleaned with pure ethyl alcohol.
- (3) The surface was then scrubbed with a water paste of levigated alumina and cleaned until water wet the surface readily.
- (4) It was brushed under running water to remove the levigated alumina.
- (5) Then it was rinsed in distilled water.
- (6) Finally, the surface was dried with dry compressed air. (Surfaces not dried quickly have a tendency to oxidize.)

The riders were cleaned by the same procedure; but since they were not sandblasted, step 1 was not necessary.

Film Application

A thinner consisting of N-methyl-pyrrolidone and xylene was added to the polyimide varnish to obtain a sprayable solution. The polyimide solution was sprayed onto each

disk by using an artists airbrush. The film did not dry rapidly. Thus, in order to eliminate "running," only a thin film of polyimide was applied at one time. The disk was baked at 100^o C for 1 hour and then another thin film was applied, etc. When the desired thickness of 25±2 micrometers was obtained, the film was cured. The curing procedure was to heat the film at 100^o C for 1 hour and then to heat it for an additional 1 hour at 300^o C.

Experimental Technique

The procedure for conducting the friction transition tests was as follows: A rider and a polyimide-coated disk (polyimide was not applied to the rider) were inserted into the friction apparatus. The test chamber was sealed, and the desired atmosphere was purged through the chamber for 15 minutes before the test was started. The flow rate was 1500 cubic centimeters per minute. This flow rate maintained a slight positive pressure in a chamber whose volume was 2000 cubic centimeters.

After the purge was completed, the disk was heated to the desired temperature. Then the disk was set into rotation, and the load applied.

In order to determine the temperature at which the large friction transition occurred, the temperature of the disk was raised to a temperature between 105^o and 160^o C and held constant. The film was then "run in" (process by which the friction coefficient goes from a high value to a low value) at this temperature until a stable friction coefficient was obtained. The temperature was then gradually lowered until the friction transition occurred. Test conditions were a dry argon atmosphere (10 ppm H₂O), a sliding velocity of 1.6 meters per second (600 rpm), and loads of either 500 or 1000 grams.

In order to determine the effect of velocity on the friction transition, a series of experiments were conducted in a dry argon atmosphere (100 ppm H₂O) with an applied load of 500 grams and at velocities of 0.027, 0.13, 0.27, 0.53, and 1.33 meters per second (10, 50, 100, 200, and 500 rpm). The test procedure for these experiments was to run in the film at 150^o C at 0.27 meter per second (100 rpm) for 5 minutes. The specimens were then disengaged, and the desired velocity obtained. The specimens were reloaded, and the temperature was lowered at the rate of approximately 3^o C per minute. Several experiments were performed on the same wear track; the velocity was changed for each test in a random order. After each individual experiment the temperature of the film was raised to 150^o C, the film was run in at 100 rpm for 5 minutes, and then the procedure was repeated.

In order to determine the correlation with TBA data, the polyimide film was run in dry argon (10 ppm H₂O) at 150^o C until the friction stabilized. A load of 500 grams and a velocity of 1.6 meters per second (600 rpm) were used. The temperature was gradually lowered until the friction transition occurred. The load was removed, and the disk

reheated to 150^o C. The load then was reapplied and the film was run in as previously stated. After running in, the temperature was raised to 500^o C at the rate of approximately 3^o C per minute.

In order to determine the effect of heating the film to 500^o C, a new rider was run on the same disk but on a track with a diameter just slightly larger than the one used in the previous test. The same experimental procedure was used.

Temperature Measurement

Two methods of measuring temperature were employed. The first was an infrared optical pyrometer, which could measure temperatures as low as 30^o C. By using this instrument, friction as a function of temperature was plotted directly on an x-y recorder. The second method was to use liquid crystals. Liquid crystals have the property of changing colors as a function of temperature. The liquid crystals were "painted" with a brush on the outer portion of the disk (outside the disk wear track) (fig. 4). Extreme care was taken so that liquid crystal material would not get into the contact area. By visually observing the color change of the liquid crystals the temperature of the disk could be determined. This temperature was then manually recorded on a strip chart.

RESULTS

Effect of Temperature

In a previous study (refs. 9 and 11), it was noted that a large decrease in friction and a corresponding increase in wear life occurred for polyimide films somewhere between 25^o and 100^o C. One of the objects of this study was therefore to more precisely locate the temperature at which these phenomena occurred. Thus, a series of experiments were conducted in a dry argon atmosphere (10 ppm H₂O) at a speed of 1.6 meters per second (600 rpm) and under a load of 1 kilogram (for details, see the section Experimental Technique).

Figure 5 is a plot of temperature and friction coefficient as a function of time for a representative experiment. For the first 10 minutes of the test the temperature was held constant at 105^o C. The friction coefficient during this time went from a high value of 0.23 to a minimum value of 0.03. It took about 7 minutes of sliding time for this to occur. This run-in process is believed to be an orientation phenomenon which only occurs at temperatures above the transition temperature. This was noted previously in reference 11, where it was found that, in dry atmospheres (10 to 20 ppm H₂O), a

run-in process occurs at 100° C but not at 25° C. At 25° C, the friction coefficient starts at 0.20 or higher and increases in value with time until the film is completely worn away.

After 10 minutes of sliding at 105° C, the induction heating unit was turned off and the film was allowed to cool, as the temperature-against-time curve (fig. 5) illustrates. As the temperature decreased, the friction coefficient remained nearly constant at the value of 0.03. When the temperature reached 50° C, the friction coefficient suddenly increased. Upon further reduction in temperature, it reached a value of 0.25, a value equivalent to the friction coefficient obtained before the run-in. The induction heating unit was then turned back on, and the temperature of the film was slowly increased. Figure 5 shows the transition to be reversible; however, the friction coefficient did not get back to its originally minimum value of 0.03 until the film temperature was 64° C. This might be expected, since the orientation process is time dependent.

Figure 6 presents data points from five different tests which were performed under the same conditions as previously stated, except that the temperature in these tests was decreased from 150° C ± 10° C rather than from 105° C. The figure shows that there is considerable scatter in the friction data below 90° C. This indicates that there may be a broad band of temperatures under which the friction transition occurs. Such conditions as prehistory of the film, sliding velocity, dryness of the atmosphere, etc., might affect the exact temperature at which the friction transition occurs.

Effect of Sliding Velocity

In order to determine if sliding velocity had an effect on the friction transition, a series of experiments were conducted in a dry argon atmosphere (100 ppm H₂O), under an applied load of 500 grams, and at sliding velocities of 0.027, 0.13, 0.27, 0.53, and 1.33 meters per second. Three tests were performed at each velocity (see the section Experimental Technique for the testing procedure).

Table I presents data taken for each of these tests, as well as averages for each velocity. Given in the table are the temperature at which the friction coefficient first started to increase in value; the temperatures at which the friction coefficient reached values of 0.05, 0.10, and 0.20; and the number of sliding revolutions that elapsed before the friction coefficient reached values of 0.10 and 0.20.

The data from the table indicate that sliding velocity (in the range 0.027 to 1.33 m/sec) was not a major factor in determining the temperature at which the friction transition occurred. The temperature at which the friction coefficient first started to increase (all tests included) ranged from 100° to 116° C; however, no trend concerning velocity dependence is apparent from these data. The same is true for the temperature

at which the friction coefficient reached values of 0.05, 0.10, and 0.20.

There was a trend, however, for the friction coefficient to remain at a lower value (to a lower temperature) as velocity was increased. Figure 7, where representative friction traces are plotted as a function of temperature, illustrates this trend. For the slowest test velocity (0.027 m/sec) the friction trace was rough, and the value of the friction coefficient increased gradually with decreasing temperature. As the test velocity was increased, the traces tended to become smoother, and the friction coefficient tended to stay at a lower value to lower temperatures. When the friction coefficient did start to increase, however, it did so at a faster rate.

The number of revolutions (in cycles) that it took the friction coefficient to reach values of 0.10 and 0.20 are also given in table I. If the rotational speed (or velocity) was divided into the number of cycles it took to reach a certain friction coefficient for each test, approximately the same value was obtained for all test velocities. Since the films cooled at approximately the same rate, this is an indication that the number of passes over a wear track is not a major factor in determining the friction transition.

Comparison to Thermomechanical Behavior

In a discussion included in reference 9, Solomon and DeGee compare the friction and wear life data of that paper to thermomechanical absorption data obtained by Gillham using the TBA technique (ref. 12). The data they use for comparison were obtained by Gillham on the polymer polybenzimidazole, not polyimide. Their main point is to suggest that there may be a correlation between the friction and wear life properties of polyimide and its own thermomechanical spectra. Thus, one of the objectives of this study was to compare the friction characteristics of the polyimide polymer PI-4701 to its own thermomechanical spectra, in an attempt to postulate why a large friction transition occurred in this polymer.

Figures 8(a) and (b) give thermomechanical data (relative rigidity and logarithmic decrement) for the polyimide used in this study as obtained by TBA.¹ The friction coefficient as a function of temperature is given in figures 8(c) and (d). The experimental technique for obtaining the TBA data is summarized in table II, and the experimental technique for obtaining the friction data is given in the section Experimental Technique.

The peaks in the logarithmic decrement curve (fig. 8(b)) reveal loss maxima, that is, the temperatures at which maximum energy is absorbed. The peak that occurs at the highest temperature is designated α , the next lower peak β , etc. Table III summarizes the TBA results which were obtained for this polyimide.

¹Tests were conducted for NASA at Princeton University under NASA purchase order C-60346-C.

It is seen in the data of table III and the data of figure 8(b) that the position of the α -peak is dependent on the thermal prehistory (curing) of the polyimide. As the temperature was increased to 500^o C, an α -peak appeared in the logarithmic decrement curve at 354^o C. However, when the temperature was reduced from 500^o C, no α -peak appeared at 354^o C, instead it remained at a value greater than 500^o C. A similar result is found in the rigidity curve of figure 8(a); as the temperature was increased to 500^o C, there was a sharp drop in the relative rigidity of the polyimide, which reached a minimum at 377^o C. Upon reduction of the temperature from 500^o C, no minimum was found.

The lower-temperature relaxation peaks, the β -peak and the γ -peak, were not noticeably affected by the thermal prehistory of the polyimide. The β -peak occurred at 179^o C, and the γ -peak occurred between -112^o and -113^o C. The horizontal plateau in the increasing temperature curve is believed to arise because of an overlap in the α and β relaxation processes. Since the α -peak was increased to a higher temperature upon heating, the two processes did not overlap in the decreasing temperature curve.

The peak designated $\beta_{\text{H}_2\text{O}}$ is due to water. The dry nitrogen atmosphere contained very small quantities of H₂O. Upon cooling below freezing, the H₂O cumulatively condensed on the walls of the chamber. Upon heating above -190^o C, the water transferred to the specimen (since it was warmer than the chamber walls). The size of the peak points out how sensitive polyimide is to the adsorption of water, since the amount of water in the chamber was extremely small.

The friction properties of the polyimide films as a function of temperature are shown in figures 8(c) and (d). The friction traces shown were obtained by either increasing (fig. 8(c)) or decreasing (fig. 8(d)) the temperature at the rate of approximately 3^o C per minute after the films had been run in at 150^o C (see the section Experimental Technique). Two friction traces are shown in each figure. One was obtained on a polyimide film cured at 300^o C, while the other was obtained on a slightly different wear track on the same film after it had been heated to 500^o C in an argon atmosphere.

The thermal prehistory (curing) of the polyimide film did not seem to markedly affect the temperature at which the large friction transition occurred (fig. 8(d)). In both friction traces there was a gradual increase in friction starting at 110^o C and then a large increase in friction at about 40^o C. The most noticeable effect of curing temperature on friction occurred above 300^o C, where the friction coefficient obtained on the 500^o C cured film was much less than the one obtained on the 300^o C cured film (fig. 8(c)). Another effect found for both curing temperatures was the existence of a friction peak between 250^o and 300^o C. This peak was found to occur at 300^o C for the 500^o C cured film as compared to 250^o C for the 300^o C cured film. The reason for this peak is obscure; it may only be an anomaly.

The large friction transition at 40^o C (fig. 8(d)) seems most likely to be associated with the β relaxation process, even though the temperatures at which they occurred

do not exactly correspond. The change in the friction properties with curing temperature above 300^o C can be associated with the α relaxation process, which is also affected by curing temperature. The next section discusses these two correlations in more detail.

DISCUSSION OF RESULTS

In a previous study (refs. 9 and 11), it was observed that the polyimide polymer PI-4701 exhibited a large transition in its friction and wear life properties somewhere between 25^o and 100^o C. As indicated in the section BACKGROUND, the mechanical properties of polymers are dependent on such factors as their molecular structure and the degree of mobility of their molecular chains. In order to postulate some possible reasons for the transition phenomena, the friction results were compared to dynamic thermomechanical data obtained by the TBA technique.

A direct correlation between a peak in the logarithmic decrement curve (fig. 8(b)) and the large friction transition temperature (fig. 8(d)) was not found. The peak closest to the friction transition is the β -peak, which occurred at 179^o C. The friction transition occurred at a considerably lower temperature, although there was a problem in defining an exact friction transition temperature. In most cases the friction coefficient started to increase in value at about 110^o C, and then at about 40^o C there was a large increase in friction coefficient. Since the friction coefficient at room temperature (25^o C) was in the range of 0.20 to 0.25, the friction transition was usually taken to be the temperature at which the friction coefficient reached this value. However, it could also be defined as the temperature at which the friction coefficient first started to increase. Considering this, it seems reasonable to assume that the process which is causing the friction transition extends over a broad temperature range.

A better correlation to TBA data might be obtained if frictional heating at the interface were taken into account. However, to do this it would be necessary to measure the temperature in the interface area. A pyrometer focused on the disk wear track showed minimal temperature rise from frictional heating. Also sliding velocity, in the range 0.027 to 1.33 meters per second, did not have a discernible effect on the friction transition temperature. This indicates that the amount of thermal energy supplied to the polyimide molecules by frictional heating was minimal.

A closer examination of what the molecular relaxation peaks (in the logarithmic decrement curve) represent is necessary in order to draw some conclusions as to what happens during the friction transition. A relaxation peak represents the temperature at which a particular molecular motion achieves its greatest degree of freedom. Increasing the temperature above this point cannot produce further motion, but the motion continues unhindered. As the temperature is decreased below the peak, the motion re-

sponsible for the loss mechanism is continuously hindered, until at some temperature it becomes completely frozen. This is the onset temperature of the relaxation peak. The onset temperature of a relaxation peak is not easily determined. It could be a minimum or an inflection in the curve at some temperature below the peak.

In order to determine if the onset of the relaxation peak had any correlation to the friction transition, the first derivative of the logarithmic decrement curve was taken. Figure 9 compares the derivative of the logarithmic decrement to the friction traces of the polyimide. The derivative was taken neglecting the H₂O peak, since the friction tests were conducted under dry conditions. The temperature at which the derivative curve crosses the zero axis represents a maximum or a minimum in the logarithmic decrement curve. The peaks in the derivative curve represent inflections in the logarithmic decrement curve. Unfortunately, in the temperature range where the large friction transition occurred, no distinct maximum in the curve was found. The β -peak is of such a nature that there are no sharp inflections in this region. The curve does reach a maximum of sorts at about 0° C. This indicates that there was some motion associated with this relaxation peak occurring at 0° C.

The most likely cause of the friction transition seems to be that a certain activation energy or a certain degree of freedom is needed by the molecules in order for them to assume a structure that is conducive to easy shear and therefore low friction. The question is, what type of molecular movement and what change in structure are taking place?

As more is learned about polymer friction, it is becoming increasingly apparent that a certain degree of order must exist at the sliding interface if low friction is to occur. For example, Pooley and Tabor (ref. 44) have demonstrated that when low friction occurred in the polymer PTFE, the molecular chains of this material were oriented in the sliding direction. Other researchers have also observed similar molecular order with PTFE and other polymers (refs. 45 to 50).

The results of this study suggest that polyimide also undergoes an ordering process. However, unlike PTFE, a certain thermal energy must be supplied to the polyimide molecules to enable them to reorient themselves into a structure conducive to low friction. It is possible that the friction properties of PTFE may also be related to molecular relaxations (ref. 51). At temperatures below ambient, PTFE exhibits high friction similar to polyimide. There is a relaxation peak in this temperature range for PTFE which may correlate to this change in friction characteristic.

Considering the structure of polymers (see the section BACKGROUND), a possible explanation for the friction transition might be the transformation of folded chains into extended chains. As a result of shearing deformation, the chains become progressively oriented in the direction of the stress. The fact that the friction transition is reversible indicates that the molecules can revert to their original structure if insufficient thermal

energy is supplied. It may be that the ends of the chains fold as the temperature is decreased below a certain value, thus inhibiting easy shear.

Another interesting result of this study is the effect that thermal prehistory had on the friction properties of the polyimide film. Heating the film in a dry argon atmosphere (10 ppm H_2O) to $500^{\circ}C$ dramatically improved the friction properties of the polyimide film above $300^{\circ}C$; but below $300^{\circ}C$ the friction properties were not markedly affected (fig. 8). Heating the film to $500^{\circ}C$ had the effect of shifting the α -peak to a temperature greater than $500^{\circ}C$. The α -peak is usually considered to denote the temperature T_G at which the glass transition occurs; that is, where the material changes from rubbery to glassy or the reverse. On a molecular level it is considered to denote the temperature at which large-scale movements of the molecular chain can take place (ref. 18).

By heating the polyimide to higher temperatures, a more complete polymerization of the polyimide can take place, such as chain extension, crosslinks, etc. This inhibits large-scale molecular movements, thus making the polyimide much more rigid at the higher temperatures (fig. 8(a)). It should be pointed out that the curing temperature cannot be increased in an air atmosphere, since polyimide oxidizes at elevated temperatures.

Increasing the α -peak to a value greater than $500^{\circ}C$ did not affect either the β - or γ -peak or the temperature at which the large friction transition occurred. This indicates that the α relaxation process has no effect on the large friction transition that occurs at approximately $40^{\circ}C$.

No mention has been made thus far of the γ -peak or the β_{H_2O} -peak. Since both these peaks occur below the friction transition temperature, the molecular motions associated with them extend through the region of the friction transition. Thus, it could be that the motion associated with the γ -peak is a factor contributing to the friction transition. The friction results from references 9 and 11 indicated that when H_2O was present in the test atmosphere, detrimental friction and wear life results were obtained. Thus, the molecular relaxation associated with the β_{H_2O} -peak may be detrimental to producing an ordered film at the interface.

SUMMARY OF RESULTS

Correlation of experimental friction results and torsional braid analysis (TBA) results on a polyimide film, along with a literature study of polymer structure, have yielded the following results:

1. When the temperature was lowered from $150^{\circ}C$, at the rate of $3^{\circ}C$ per minute, a gradual increase in friction was found to commence at about $110^{\circ}C$. A large increase occurred at $45^{\circ}C \pm 5^{\circ}C$.

2. TBA data indicated that molecular motion of some form was being initiated at a temperature below the friction transition temperature. The amount of movement increased with increased temperature and reached its maximum at 179⁰ C.

3. This molecular movement or additional degree of freedom may allow the mechanical stress of sliding to reorder the molecules into a structure which is conducive to easy shear, such as an extended chain structure with the chains oriented parallel to the sliding direction.

4. Heating the polyimide film in dry argon to 500⁰ C increased the TBA α relaxation peak (glass transition) to a temperature above 500⁰ C. This did not noticeably affect the large friction transition, but it did markedly improve the friction properties at temperatures between 300⁰ and 500⁰ C.

5. Varying the sliding velocity (in the range 0.027 to 1.33 m/sec) did not markedly affect the friction transition temperature; however, in general, friction was "rougher" as velocity was reduced.

6. The friction transition was found to be reversible when the temperature was varied back and forth through the transition temperature region.

Lewis Research Center,
National Aeronautics and Space Administration,
Cleveland, Ohio, January 8, 1975,
505-04.

REFERENCES

1. George, D. E.; and Grover, E. B.: Precision Parts from Polyimide Resins. *Materials Performance*, vol. 11, no. 4, April 1972, pp. 29-32.
2. Gillham, J. K.; Halbok, K. D.; and Stadnicki, S. J.: Thermomechanical and Thermogravimetric Analyses of Systematic Series of Polyimides. *J. Applied Polymer Sci.*, vol. 16, no. 10, Oct. 1972, pp. 2595-2610.
3. Gillham, J. K.; and Gillham, H. C.: Polyimides: Effect of Molecular Structure and Cure on Thermomechanical Behavior. *Polymer Eng. Sci.*, vol. 13, no. 6, Nov. 1973, pp. 447-454.
4. Gillham, J. K.; and Roller, M. B.: Advances in Instrumentation and Technique of Torsional Pendulum and Torsional Braid Analyses. *Polymer Eng. Sci.*, vol. 11, no. 4, July 1971, pp. 295-304.
5. Loomis, W. R.; Johnson, R. L.; and Lee, J.: High-Temperature Polyimide Hydraulic Actuator Rod Seals for Advanced Aircraft. SAE Paper 700790, Oct. 1970.

6. Sliney, Harold E.; and Johnson, Robert L.: Graphite-Fiber - Polyimide Composites for Spherical Bearings to 340° C (650° F). NASA TN D-7078, 1972.
7. Coulson, W. F.; Gruen, T.; and Amstutz, H. C.: Local Tissue Biocompatibility. A Report of a Workshop on Fundamental Studies for Internal Structural Prosthesis. National Academy of Sciences, 1973, pp. 43-45.
8. Fusaro, Robert L.; and Sliney, Harold E.: Graphite Fluoride as a Lubricant in a Polyimide Binder. NASA TN D-6714, 1972.
9. Fusaro, Robert L.; and Sliney, H. E.: Lubricating Characteristics of Polyimide Bonded Graphite Fluoride and Polyimide Thin Films. ASLE Preprint 72LC-7C-3, Oct. 1972.
10. Campbell, M.; and Hopkins, V.: Development of Polyimide Bonded Solid Lubricants. *Lub. Eng.*, vol. 23, no. 7, July 1967, pp. 288-294.
11. Fusaro, Robert L.: Friction and Wear Life Properties of Polyimide Thin Films. NASA TN D-6914, 1972.
12. Gillham, J. K.: Torsional Braid Analysis. A Semimicro Thermomechanical Approach to Polymer Characterization. TR-4, Princeton Univ. (AD-734005), 1971.
13. Bernier, G. A.; and Kline, D. E.: Dynamic Mechanical Behavior of a Polyimide. *J. Applied Polymer Sci.*, vol. 12, no. 3, Mar. 1968, pp. 593-604.
14. Lim, T.; Frosini, V.; Zaleckas, V.; Morrow, D.; and Sauer, J. A.: Mechanical Relaxation Phenomena in Polyimide and Poly (2, 6-dimethyl-p-phenylene oxide) from 100° K to 700° K. *Polymer Eng. Sci.*, vol. 13, no. 1, Jan. 1973, pp. 51-58.
15. Butta, Enzo; DePetris, Silvano; and Pasquini, Mario: Young's Modulus and Secondary Mechanical Dispersions in Polypyromellitimide. *J. Applied Polymer Sci.*, vol. 13, no. 6, June 1969, pp. 1073-1081.
16. Boyer, Raymond F.: Introductory Remarks for the Symposium on Transitions and Relaxations in Polymers. *J. Polym. Sci.*, pt. C, no. 14, 1966, pp. 3-14.
17. Turley, S. G.; and Keskkula, H.: A Survey of Multiple Transitions by Dynamic Mechanical Methods. *J. Polym. Sci.*, pt. C, no. 14, 1966, pp. 69-87.
18. Boyer, R. F.: Dependence of Mechanical Properties on Molecular Motion in Polymers. *Polymer Eng. Sci.*, vol. 8, no. 3, July 1968, pp. 161-185.
19. Hoffman, J. D.; Williams, G.; and Passaglia, E.: Analysis of the α , β , and γ Relaxations in Polychlorotrifluoroethylene and Polyethylene: Dielectric and Mechanical Properties. *J. Polym. Sci.*, pt. C, no. 14, 1966, pp. 173-235.

20. Lipatov, Y. S.; and Fabulyak, F. Y.: Relaxation Processes in the Surface Layers of Polymers at the Interface. *J. Applied Polymer Sci.*, vol. 16, no. 8, Aug. 1972, pp. 2131-2139.
21. Eby, R. K.; and Sinott, K. M.: Transitions and Relaxations in Polytetrafluoroethylene. *J. Applied Phys.*, vol. 32, no. 9, Sept. 1961, pp. 1765-1771.
22. Stachurski, Z. H.; and Ward, I. M.: Mechanical Relaxations in Polyethylene. *J. Macromol. Sci.-Phys.*, vol. B3, no. 3, Sept. 1969, pp. 485-494.
23. Chrissman, J. M.; and Passaglia, E.: Mechanical Relaxations in Polychlorotrifluoroethylene. *J. Polym. Sci.*, pt. C, no. 14, 1966, pp. 237-245.
24. Wischmann, Kenneth B.; and Brassell, Gilbert W.: Low Temperature Transitions in a Crosslinked Urethane. *Polymer Eng. Sci.*, vol. 13, no. 2, Mar. 1973, pp. 120-124.
25. Peterlin, A.: Crystalline Character of Polymers. *J. Polym. Sci.*, pt. C, no. 9, 1965, pp. 61-89.
26. Billmeyer, Frederick W., Jr.: Text Book of Polymer Science. 2nd ed., Wiley-Interscience, 1971.
27. Geil, Phillip H.: Polymer Single Crystals. Wiley-Interscience, 1963.
28. Kargin, V. A.: Structure and Phase State of Polymers. *J. Polym. Sci.*, vol. 30, 1958, pp. 247-258.
29. Robertson, Richard E.: Polymer Order and Polymer Density. *J. Phys. Chem.*, vol. 69, no. 5, May 1965, pp. 1575-1578.
30. Yeh, G. S. Y.: A Structural Model for the Amorphous State of Polymers: Folded-Chain Fringed Micellar Grain Model. *J. Macromol. Sci.-Phys.*, vol. 86, no. 3, 1972, pp. 465-478.
31. Treloar, L. R.: The Physics of Rubber Elasticity. Oxford University Press (London), 1958.
32. Bryant, W. M.: Polythene Fine Structure. *J. Polym. Sci.*, vol. 2, 1947, pp. 547-564.
33. Hermann, K.; and Gerngross, O.: Die Elastizitat des Kautschuks. *Kautschuk*, vol. 8, 1932, p. 181.
34. Hermann, K.; Gerngross, O.; and Abitz, W.: Zur Rontgenographischen Struktur forschung des Gelatinemicells. *Z. Physik Chem.*, vol. 8-18, 1930, p. 371.
35. Bunn, C. W.; and Alcock, T. C.: Texture of Polyethene. *Trans. Faraday Soc.*, vol. 41, 1945, pp. 317-325.

36. Keller, A.: Single Crystals of Polymers. *Inst. Textile de France*, vol. 17, no. 105, 1963, pp. 301-334.
37. Hoffman, J. D.: Theoretical Aspects of Poly. Crys. With Chain Folds. *Soc. Petroleum Eng. Trans.*, vol. 4, no. 4, 1964, p. 315.
38. Anderson, Franklin R.: Morphology of Isothermally Bulk-Crystallized Linear Polyethylene. *J. Applied Phys.*, vol. 35, no. 1, Jan. 1964, pp. 64-70.
39. Keith, H. D.; and Padden, F. J., Jr.: Spherulitic Crystallization from the Melt: I. Fractionation and Impurity Segregation and Their Influence on Crystalline Morphology. *J. Applied Phys.*, vol. 35, no. 4, Apr. 1964, pp. 1270-1285.
40. Wunderlich, B.; and Davidson, T.: Extended Chain Crystals. I. General Crystallization Conditions and Review of Pressure Crystallization of Polyethylene. *J. Polym. Sci.*, pt. A-2, vol. 7, 1969, pp. 2043-2050.
41. Wunderlich, B.: Extended Chain Crystals of Linear High Polymers. *Pure Applied Chem.*, vol. 31, no. 1-2, 1972, pp. 49-63.
42. Nomura, Shunji; Asanuma, A.; Suehiro, S.; and Kawai, H.: Crystal Orientation in a Semicrystalline Polymer in Relation to Deformation of Spherulites. *J. Polym. Sci.*, pt. A-2, vol. 9, 1971, pp. 1991-2007.
43. Aharoni, S. M.: On the Rheological Phenomena of Amorphous Polymers. *J. Applied Polymer Sci.*, vol. 17, 1973, pp. 1507-1518.
44. Pooley, C. M.; and Tabor, D.: Friction and Molecular Structure: The Behavior of Some Thermoplastics. *Proc. Royal Soc. (London)*, ser. A., vol. 329, 1972, pp. 251-274.
45. Bunn, C. W.; and Howells, E. R.: Structures of Molecules and Crystals of Fluorocarbons. *Nature*, vol. 174, Sept. 18, 1954, pp. 549-551.
46. Bely, V. A.; Savkin, V. G.; and Sviridyonok, A. I.: Effect of Structure on Polymer Friction. *Wear*, vol. 18, 1971, pp. 11-18.
47. Speerschneider, C. J.; and Li, C. H.: A Correlation of Mechanical Properties and Microstructure of PTFE at Various Temperatures. *J. Applied Phys.*, vol. 34, no. 10, Oct. 1963, pp. 3004-3007.
48. Sinnott, K. M.: Mechanical Relaxations in Single Crystals of Polyethylene. *J. Polym. Sci.*, pt. C, vol. 14, 1966, pp. 141-172.
49. Makinson, K. R.; and Tabor, D.: The Friction and Transfer of PTFE. *Proc. Royal Soc. (London)*, ser. A., vol. 281, 1964, pp. 49-61.

50. Wecker, S. M.; Davidson, T.; and Baker, D. W.: Preferred Orientation of Crystallites in Uniaxially Deformed PTFE. *J. Applied Phys.*, vol. 43, no. 11, Nov. 1972, pp. 4344-4348.
51. Ludema, K. C.; and Tabor, D.: The Friction and Visco-Elastic Properties of Polymeric Solids. *Wear*, vol. 9, 1966, pp. 329-348.

TABLE I. - EFFECT OF VELOCITY ON THE FRICTION PROPERTIES OF POLYIMIDE FILMS

[Load, 500 g; riders, 440C stainless steel; atmosphere, dry argon (100 ppm H₂O).]

Test	Rotational speed, rpm	Sliding (linear) velocity, m/sec	Temperature (°C) at which friction coefficient-				Number of revolutions (cycles) before friction coefficient reached values of-	
			Started to increase	Reached values of-			0.10	0.20
				0.05	0.10	0.20		
1-5	10 ↓	0.027 ↓	108	92	72	54	166	273
2-3			102	62	53	47	275	328
2-5			103	68	48	44	319	380
Average			104	74	58	48	253	327
1-2	50 ↓	0.13 ↓	108	79	68	61	954	1 140
1-4			116	110	73	53	796	1 346
2-1			110	87	68	50	833	1 333
Average			111	92	70	55	861	1 273
1-1	100 ↓	0.27 ↓	108	90	73	54	1 630	2 670
1-3			102	65	58	51	2 400	2 880
2-7			110	66	55	48	2 535	3 185
Average			107	74	62	55	2 188	2 912
2-2	200 ↓	0.53 ↓	103	55	53	50	5 440	5 365
2-9			102	56	55	53	5 200	5 410
3-1			108	67	64	59	3 750	4 160
Average			104	59	57	54	4 797	5 145
2-6	500 ↓	1.33 ↓	100	66	62	59	9 750	10 625
2-8			110	73	72	70	10 125	10 580
3-2			110	67	65	63	8 541	9 250
Average			107	69	66	64	9 472	10 152

TABLE II. - SUMMARY OF TORSIONAL BRAID ANALYSIS
EXPERIMENTAL PROCEDURE

Rate of temperature change, °C/min:	
For temperatures >25° C	±3
For temperatures <25° C	±1
Atmosphere	Dry nitrogen gas
Drying and curing temperatures, °C:	
Heated from	25 to 100
Held 1 hr at	100
Heated from	100 to 300
Held 1 hr at	300
Cooled from	300 to 130
Held overnight at	130
Experiment temperature, °C	130 to -190 to 500 to 25

TABLE III. - SUMMARY OF TORSIONAL BRAID
ANALYSIS RESULTS

Transition type	Temperature at which peak occurred, °C	Direction of temperature variation
After drying and curing at 300° C		
γ	-113	Decreasing
	-112	Increasing
β_{H_2O}	-11	Increasing
β	179	Decreasing
α	354	Increasing
Minimum rigidity	377	Increasing
After additional heating to 500° C		
β	179	Decreasing
α	>500	Decreasing

**ORIGINAL PAGE IS
OF POOR QUALITY**

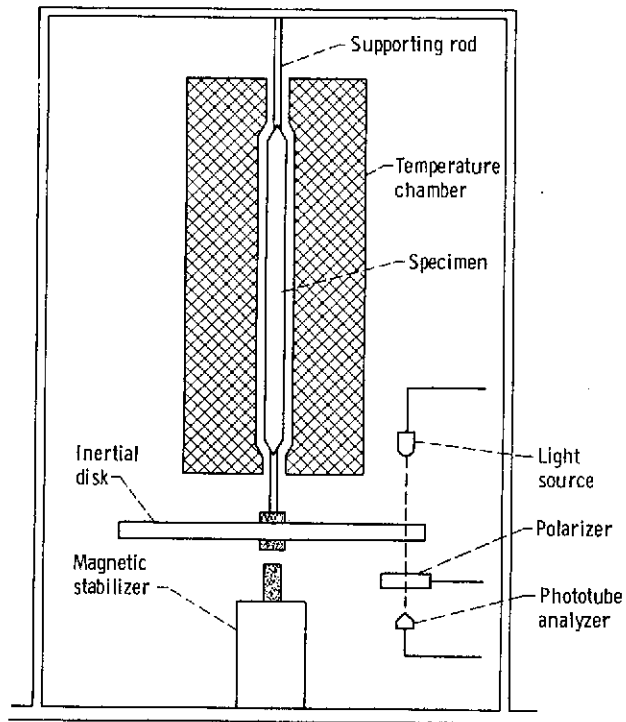
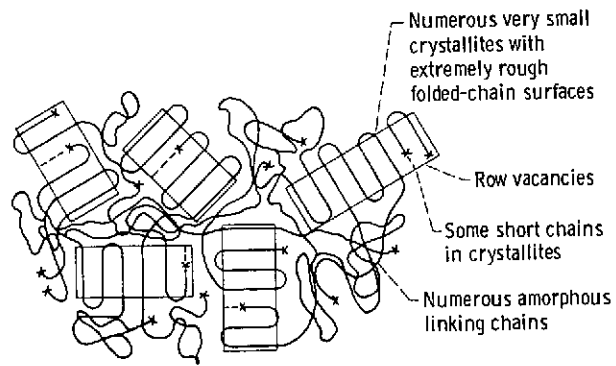
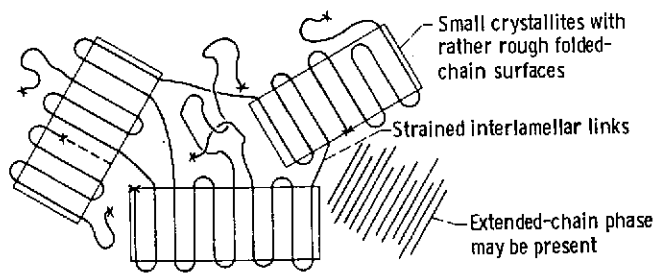

Figure 1. - Typical torsional pendulum apparatus. (From ref. 2.)

ORIGINAL PAGE IS
OF POOR QUALITY



(a) Quench crystallized.



(b) Quench crystallized and annealed.

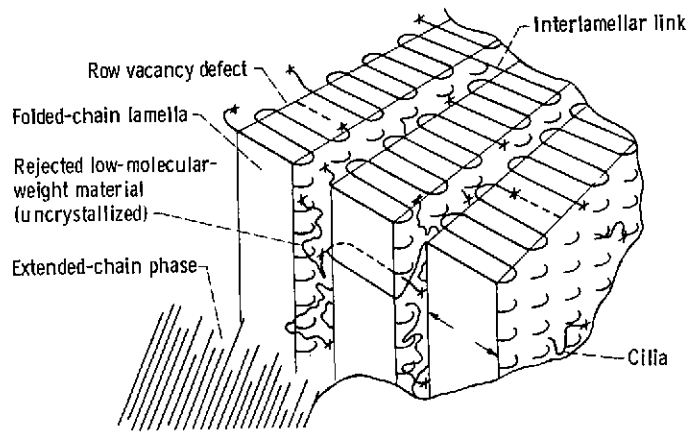

(c) Isothermally crystallized near melting point.

Figure 2. - Schematic representation of fine structure of a polymer prepared under different crystallization conditions. (From ref. 19.)

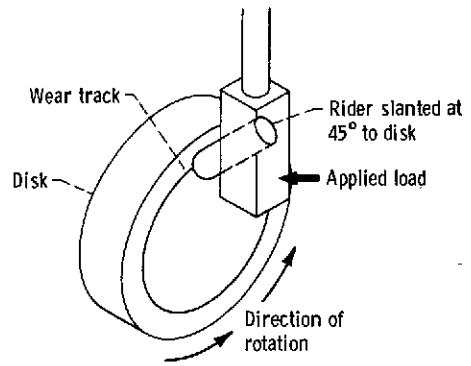

Figure 3. - Friction apparatus.

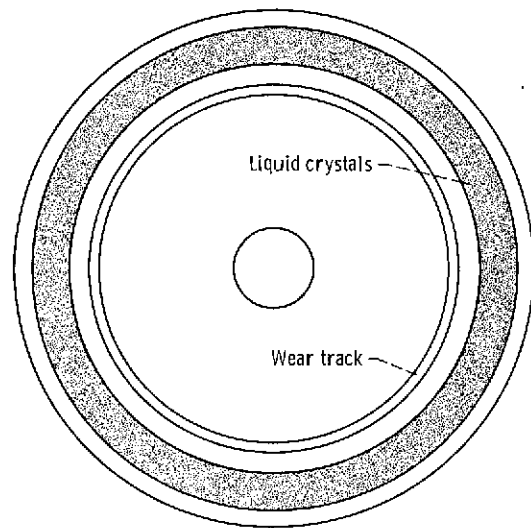

Figure 4. - Disk, showing positions of wear track and liquid crystals.

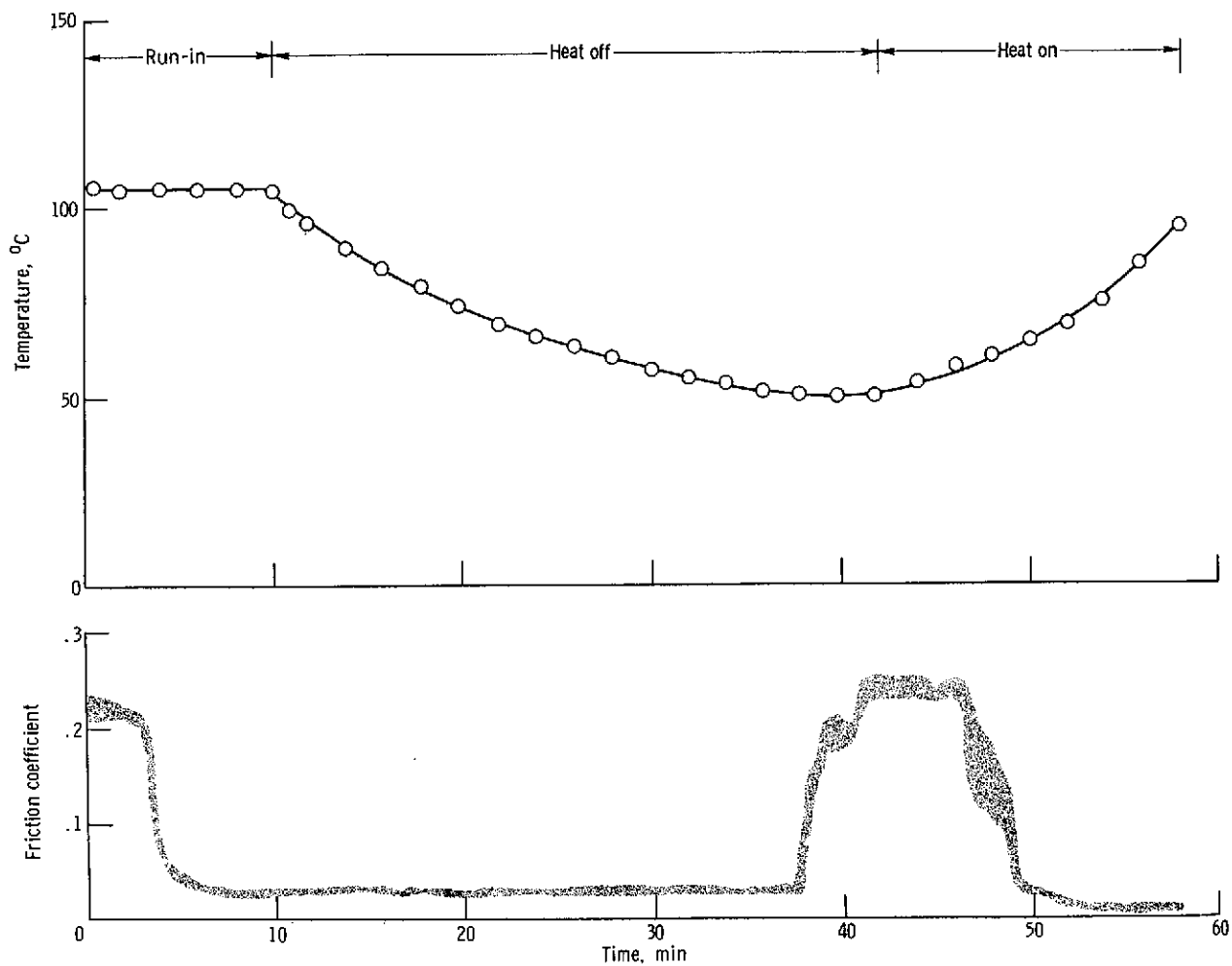

Figure 5. - Temperature and friction coefficient as function of time for a 440C stainless-steel rider sliding on a polyimide film bonded to a 440C stainless-steel disk. Load, 1 kilogram; sliding velocity, 1.6 meters per second (600 rpm); atmosphere, dry argon (10 ppm H₂O).

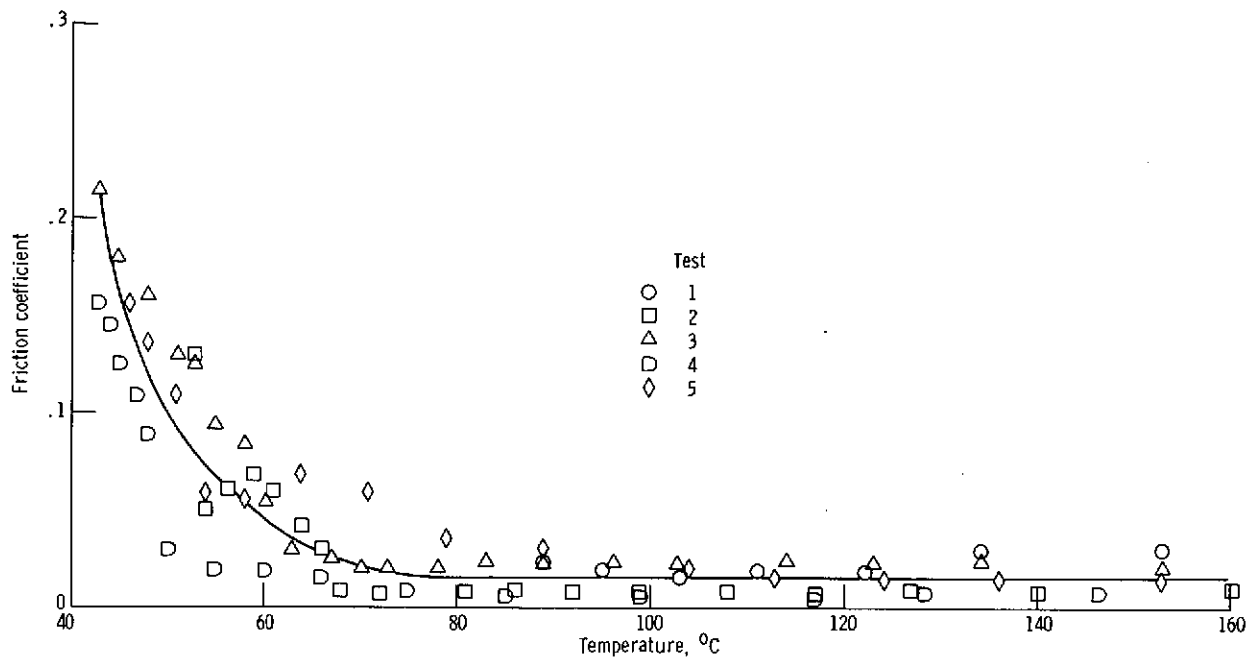

Figure 6. - Friction coefficient as function of temperature for five different tests conducted on polyimide films bonded to 440C stainless-steel disks, illustrating scatter which occurs around friction transition temperature. Test temperature lowered at rate of 3° C per minute; sliding velocity, 1.6 meters per second (600 rpm); load, 500 grams; atmosphere, dry argon (10 ppm H₂O); riders, 440C stainless steel.

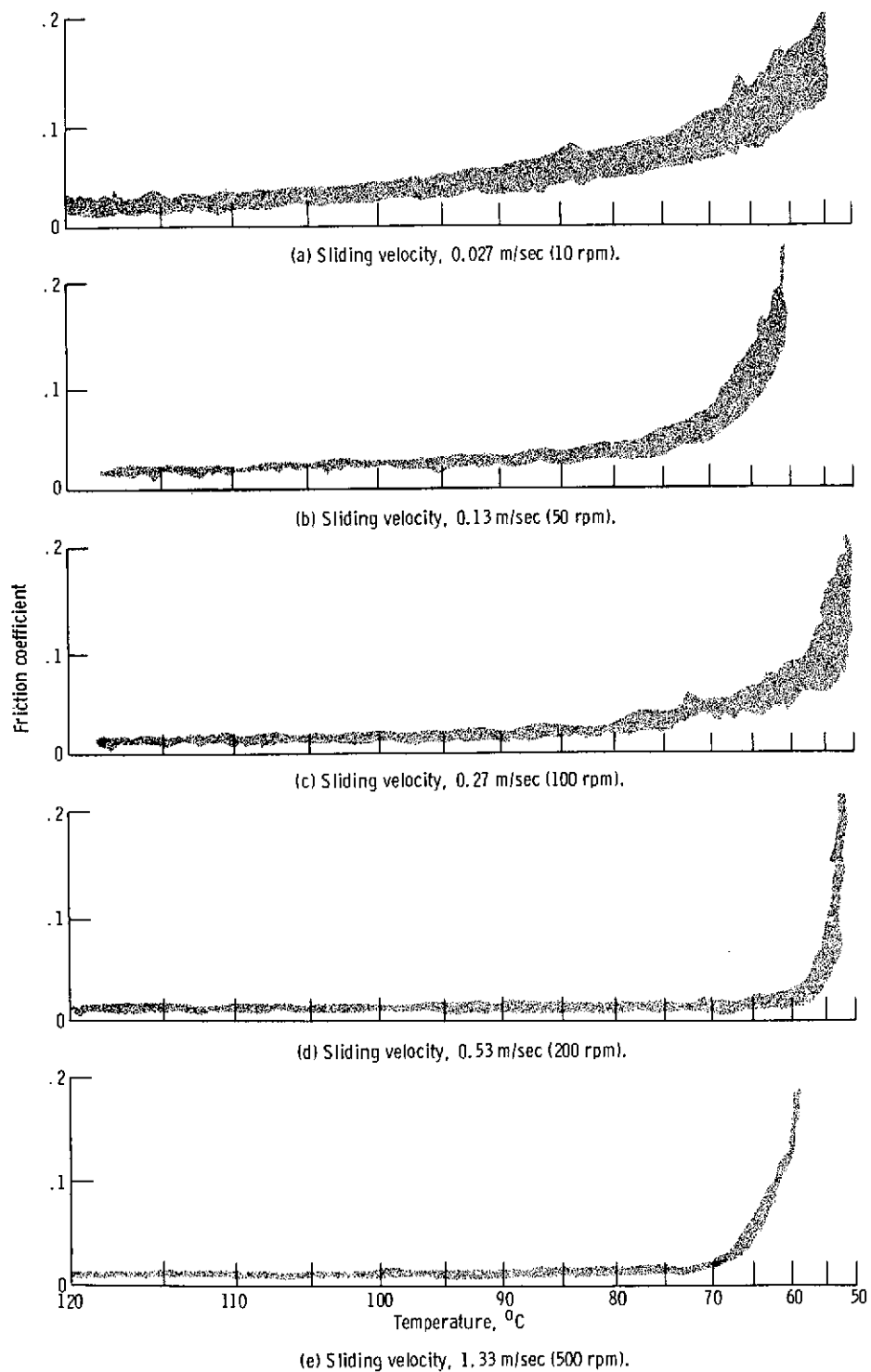
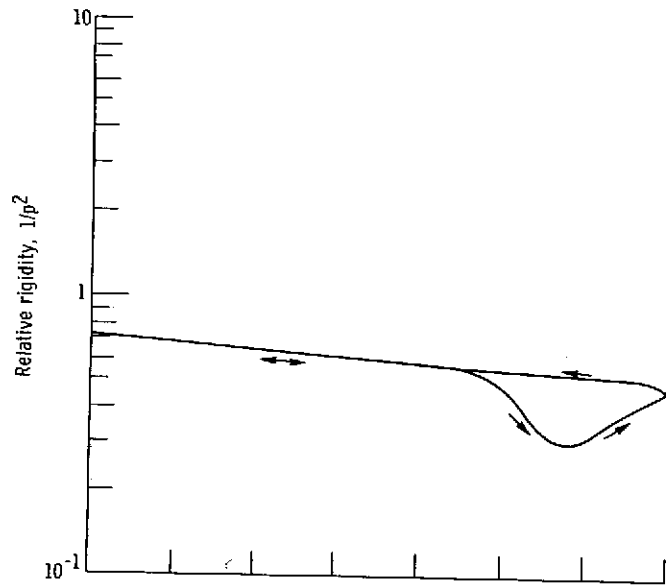
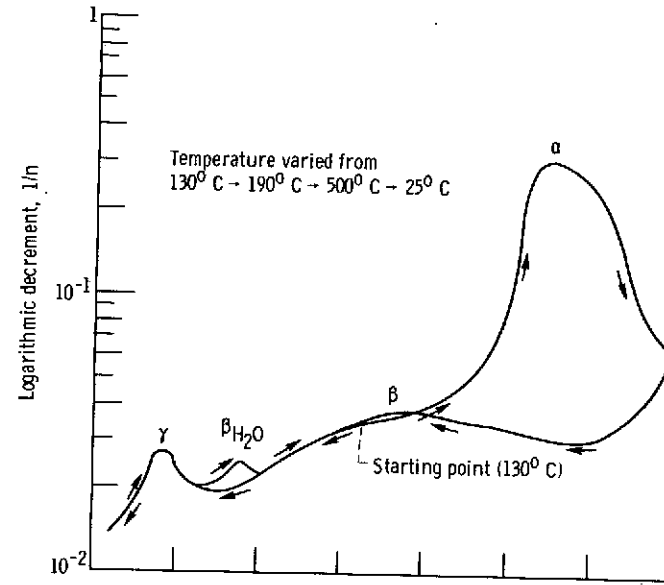

Figure 7. - Representative friction traces showing effect of velocity on friction properties of polyimide films bonded to 440C stainless-steel disks. Load, 500 grams; atmosphere, dry argon (100 ppm H₂O); riders, 440C stainless steel; wear track diameter, 5.1 centimeters.



(a) Relative rigidity.



(b) Logarithmic decrement.

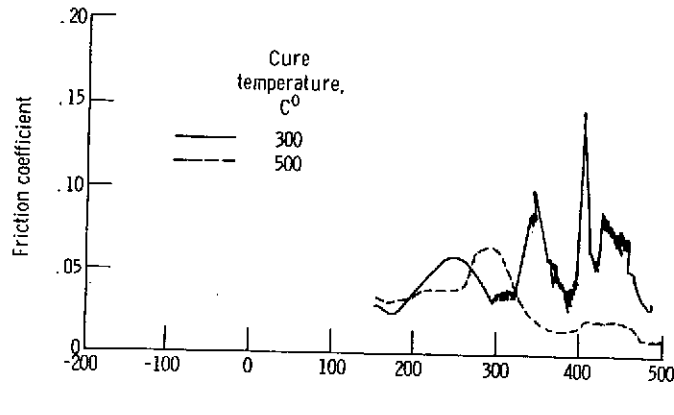

(c) Friction with increasing temperature.

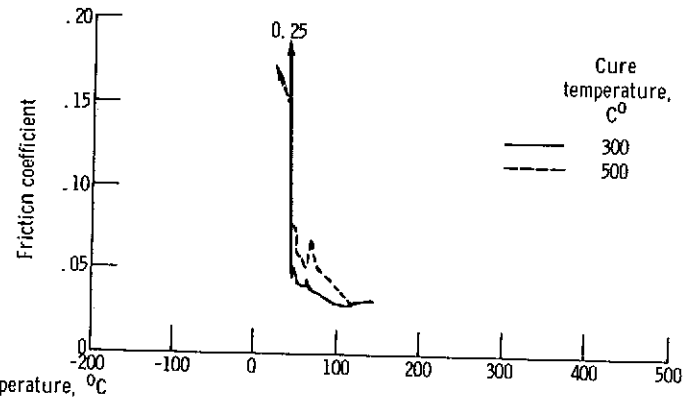

(d) Friction with decreasing temperature.

Figure 8. - Comparison of torsional braid analysis and friction data obtained on polyimide films. Experimental conditions in friction experiments: load, 500 grams; sliding velocity, 1.6 meters per second (600 rpm); atmosphere, dry argon (10 ppm H₂O); temperature increased or decreased from 150° C at rate of 3° C per minute.

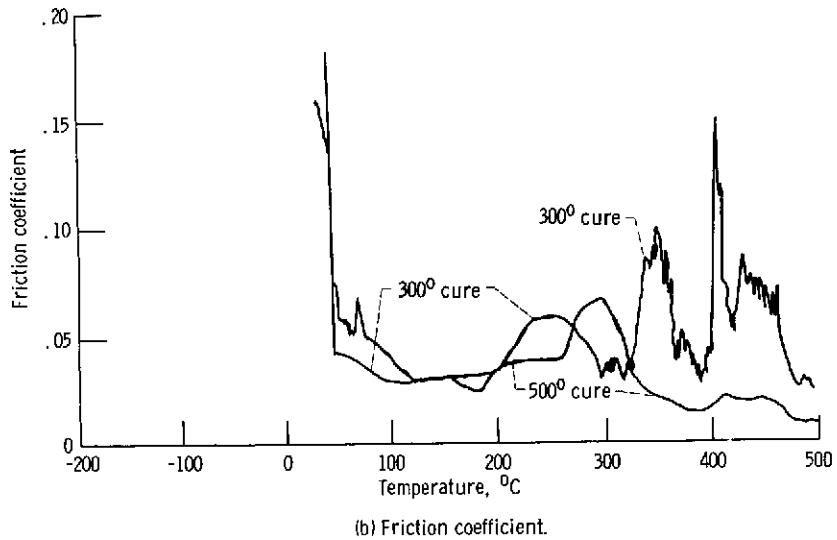
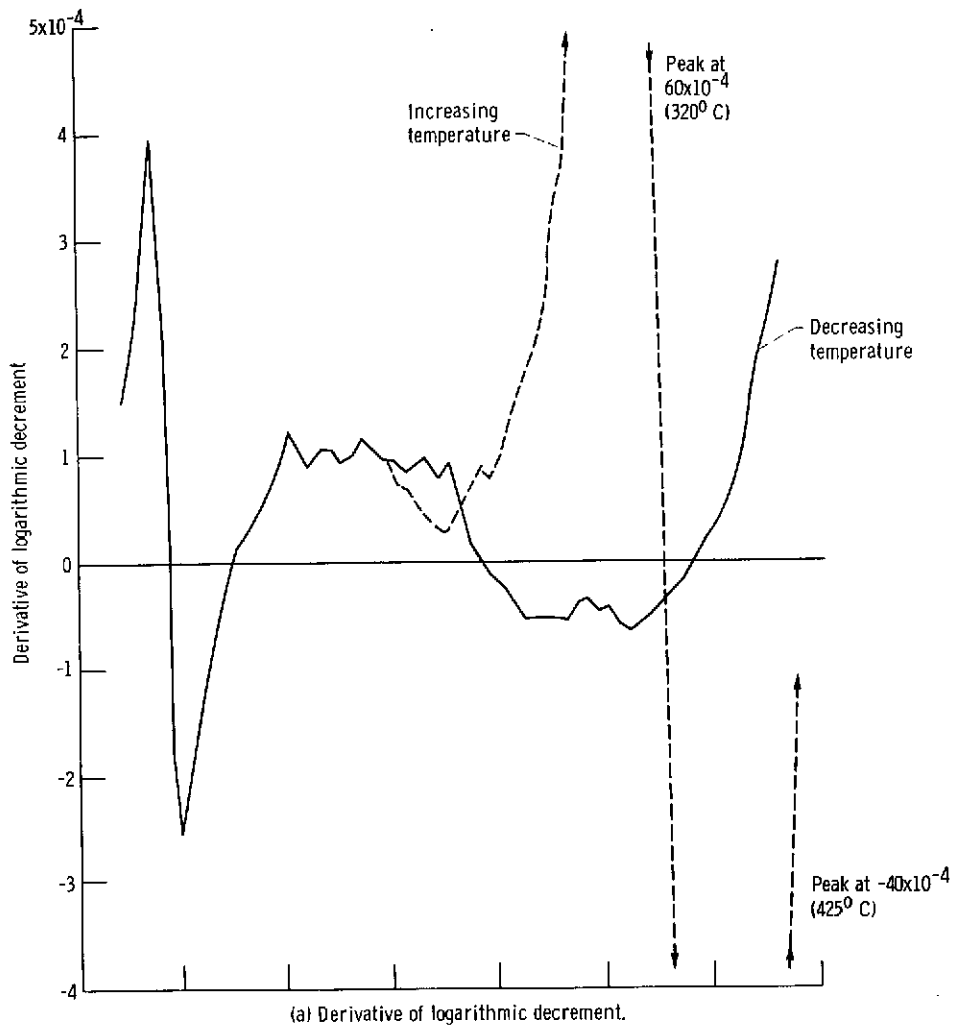

Figure 9. - Comparison of derivative of logarithmic decrement to variation of friction coefficient as function of temperature.