

## THE MAGNETIC MATRIX TIME INTERVAL METER\*

S. K. Merrill and B. V. Rodgers  
EG&G, Inc.

## ABSTRACT

A time interval meter is being developed which allows the recording of a number of event times with high resolution over a relatively long period of time.

## INTRODUCTION

In a number of experimental areas, a means for accurately recording relative times of occurrence of a series of events is needed. A technique which easily lends itself to such recording was investigated during the development of a high-speed single-transient recording device, the Magnetic Matrix Recorder.<sup>1-4</sup> The application of this technique to a time-interval meter results in a system that has capabilities for measurement of large timing intervals with high resolution, multiple channels timed directly from the same reference source, non-volatile radiation-hard data storage, computer-compatible data retrieval, and small physical size.

## DISCUSSION

The basis of the system is a matrix of thin-film magnetic recording elements, located at the intersections of two orthogonal sets of control traces (Figure 1). With no current flowing in the lines, the magnetization of an element points either direction along an "easy" axis built into the matrix during fabrication. The application of a sufficient current to a word line will pull the magnetization into the hard axis. A current in the bit line pulls the magnetization toward the easy axis, the direction depending on the polarity of the current. When the word-line current is removed, the magnetization will fall back to the easy-axis direction it is being pulled toward, recording the state of the bit-line current at that instant.

In the application of this technique to a Time Interval Meter (TIM), the bit lines are driven with bipolar signals developed by time-code generating digital logic. The word-line currents are controlled by the events of interest, with the state of the clock recorded at the time each word-line is triggered.

---

\*This work being supported by the U.S. Atomic Energy Commission, Nevada Operations Office, under Contract AT(29-1)-1183.

An initial bread-boarded prototype of such a TIM was constructed, and verified the feasibility of the concept. The unit presently under construction is an engineering prototype designed to allow a full investigation of the capabilities of this technique (Figure 2).

The time code in this unit is synchronized by a 100-MHz crystal-controlled oscillator feeding two separate generators. The first generator produces an 8-bit binary Gray code, a minimum-transition timing code, which gives 2.5-nanosecond resolution over a period of 0.64 microseconds. The second generator contains a set of delay lines, giving eight separate phase-delayed signals at the main oscillator frequency. Combined with the Gray code, this allows 0.5-nanosecond resolution, for somewhat greater than 10 bits of overall resolution.

In this design, the word-lines are controlled through buffer logic by differential ECL-compatible input signals. A record enable signal, externally supplied by the system user, serves to gate the channels only during the time of interest. A calibrate mode is also provided, in which an external calibrate signal will strobe all 16 channels at the same instant, allowing channel-to-channel calibration of the unit at any time.

Since the timing code generators are free-running, the data recorded gives the relative time of occurrence for each event. If an absolute time measurement is desired, one channel would be strobed by a reference-time signal to relate the data to an absolute standard. Also, since the code is cyclic, the units can be cascaded to increase the system time range covered. For example, adding another unit with 16 bits of Gray code to the above would allow timing over .04 seconds with 0.5-nanosecond resolution.

Although tests have not yet been performed on the engineering prototype, an idea of the overall system performance can be gathered from the bread-boarded prototype. Since the system is digital, its timing accuracy is affected primarily by variations in logic behavior caused by changes in temperature or supply voltages. With the unit calibrated, the overall accuracy is expected to be within  $\pm 1$  least-significant-bit ( $\pm 0.5$  ns in this case). The other source of error is in the oscillator driving the code generators, which has a specified accuracy of 0.0001% for the present unit. However, any external oscillator capable of being adapted to ECL levels can be used to obtain higher stability and accuracy.

To read out data from the matrix, the word line for a selected channel is strobed by the internal readout logic, and the outputs of the bit-line sense amplifiers are transferred to buffer registers. In the manual readout mode, the channel is selected with front-panel switches and the data appear on a light-emitting diode display. Under the remote mode, readout takes place through computer control via a CAMAC Dataway at rates up to the CAMAC maximum of 1 megaword/second.

The digital circuitry is primarily ECL logic, with the high-speed portions using Motorola's MECL III circuits. For both speed and size benefits, the circuits surrounding the matrix card are fabricated using hybrid circuit techniques. Both thin and thick film approaches have been used. A plug-in module arrangement allows ease of fabrication and maintenance as well as a multilayer circuit capability in the hybrid portion. The engineering prototype unit will be housed in a 1 3/4" x 19" rack chassis, with further packaging emphasis directed toward a CAMAC Instrumentation Module.

#### REFERENCES

1. K. Aaland, "The Magnetic Matrix Recorder (MMR) Principle," IEEE Trans. on Magnetics, Vol. MAG-9, No. 3, 270 (1973).
2. B. Rodgers, "A Magnetic Matrix Recorder," IEEE Trans. on Magnetics, Vol. MAG-9, No. 3, 275 (1973).
3. E. Torok, et al., "Time and Amplitude Resolution of a Thin Film Matrix Recording Device," IEEE Trans. on Magnetics, Vol. MAG-9, No. 3, 278 (1973).
4. G. Johnson and F. Friedlander, "Observation of Magnetization Configurations in Magnetic Matrix Recording Elements," IEEE Trans. on Magnetics, Vol. MAG-9, No. 3, 283 (1973).

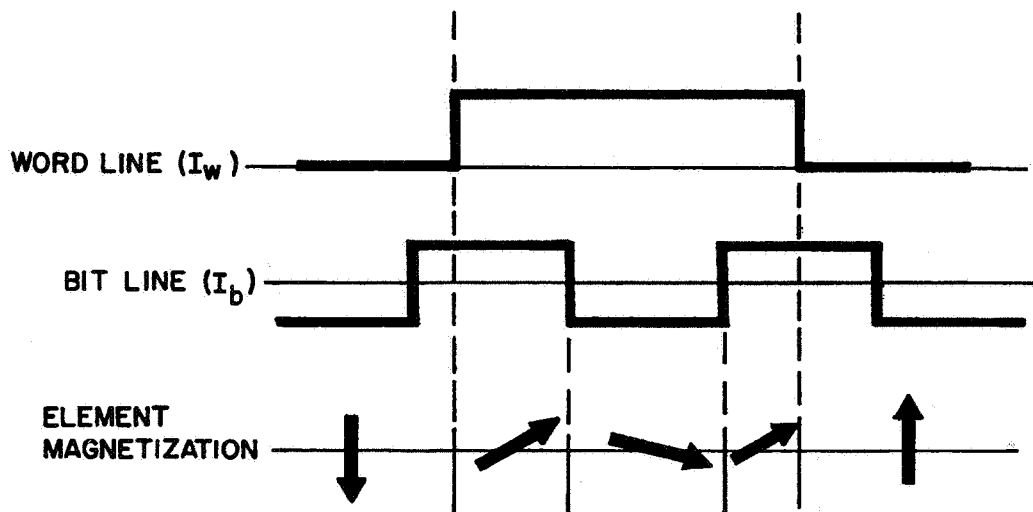
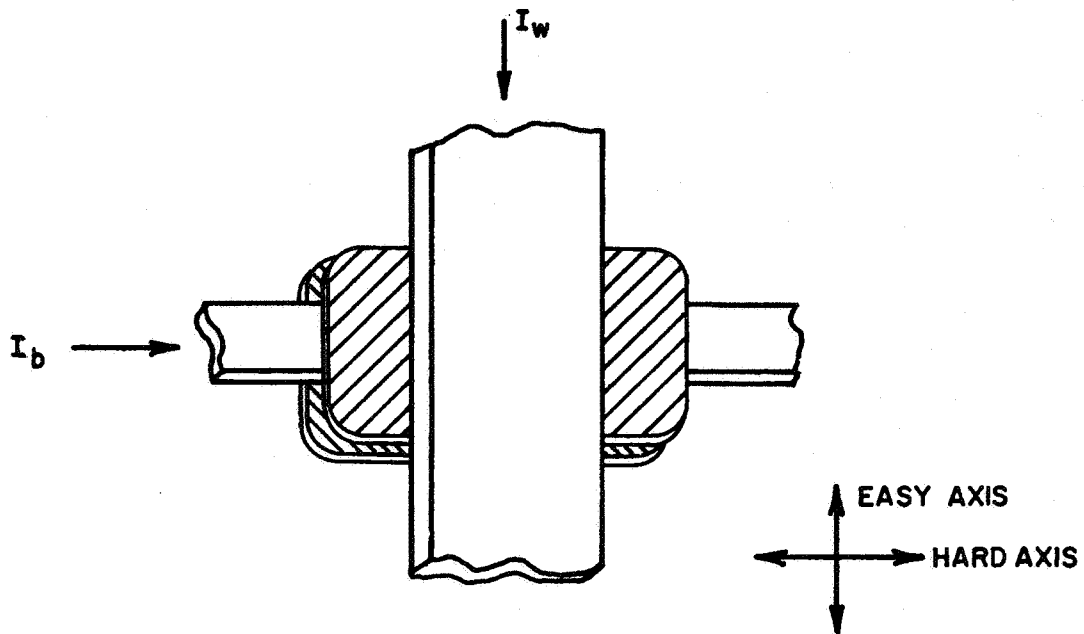

Figure 1. Magnetic matrix element.

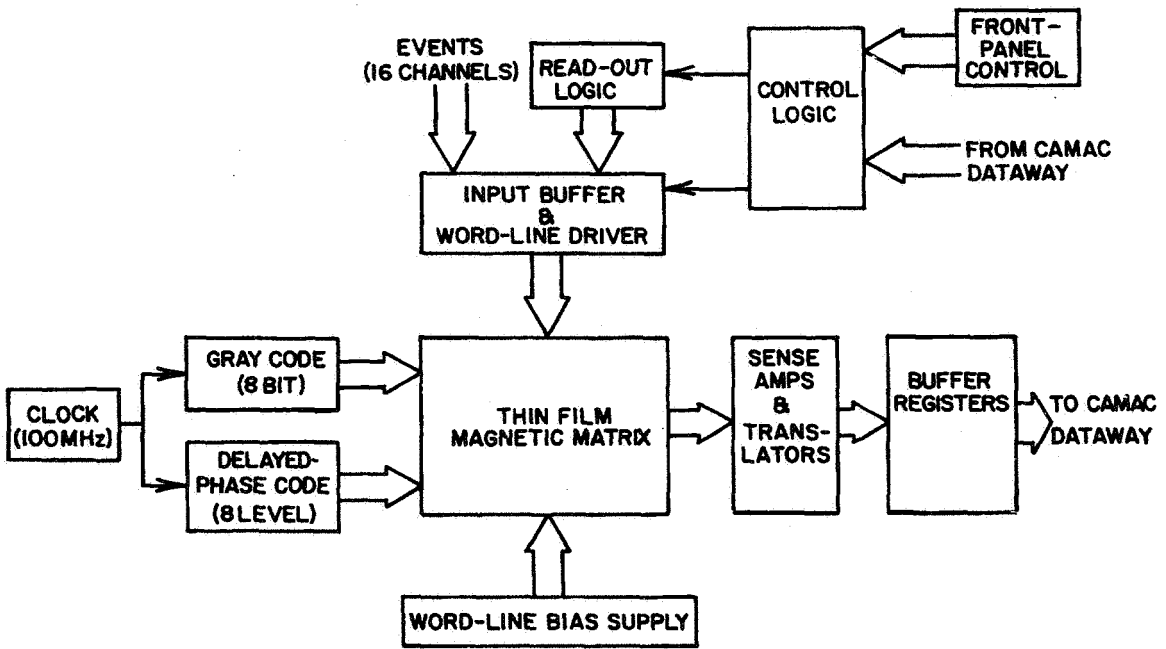

Figure 2. Magnetic matrix time interval meter.