

FREQUENCY CALIBRATION TECHNIQUES

James M. Williams, Jr. and Joseph M. Rivamonte
U. S. Army Metrology and Calibration Center
U. S. Army Missile Command, Redstone Arsenal

ABSTRACT

The techniques and standards used by the U. S. Army Metrology and Calibration Center for frequency calibration are discussed.

I. INTRODUCTION

This paper on frequency calibration techniques is intended as a tutorial discussion of the frequency calibration techniques used by the U. S. Army Metrology and Calibration Center (USAMCC). Hopefully, a discussion of the equipment and techniques used by USAMCC will assist persons faced with the task of performing similar measurements.

Background

The most stringent workload for frequency calibration by USAMCC is presently frequency counter time base oscillators. Requirements for time exist in the Army, however, these requirements are presently being met by NBS and the U. S. Naval Observatory. Pending final studies of the long-term requirements for time in the Army, USAMCC may be required to provide frequency and time calibration support. In the meantime, the Army must support crystal oscillators of virtually every type now commercially available.

Until about 1968, frequency calibration of crystal oscillators used the 5, 10, and 15 megahertz signals from WWV. As accuracy measurements exceeded the capabilities of WWV reception, USAMCC engaged in a program to improve frequency calibrations.

The first attempt to replace VHF signals visualized no dependence on radio signals. A prototype calibration system, constructed for USAMCC by a contractor, used a rubidium frequency standard for frequency calibration. Analysis by USAMCC of the rubidium system and other techniques showed that VLF signals could meet Army requirements in the most cost effective manner.

II. THE ARMY FREQUENCY CALIBRATION EQUIPMENT

The equipment now used for frequency calibration (refer to Fig. 1) includes a VLF tracking receiver, a quartz oscillator, a frequency difference meter, and an Omega gating unit. This system is used in a small number of fixed locations, but is principally used in mobile Army Calibration Teams which are referred to as "ACT's." An ACT may move as often as twice a week or may remain for 90 days in one location.

A. VLF Receiver. The VLF Tracking Receiver, Tracor Model 599J, is the key element of the system. The VLF Tracking Receiver (Tracor Model 599J) compares the phase of the received signal to the phase of a local 1 MHz frequency source and produces an error signal which is displayed by a strip chart recorder. It is used to monitor the frequency of the quartz oscillator which is then corrected as shown by the VLF receiver's phase plot.

B. Quartz Oscillator. The Quartz Oscillator, Vectron Model FS-323, MIS-10223, has a basic stability specification of ± 5 parts in 10^{10} per day. Output frequencies are 100 kHz, 1 MHz, and 5 MHz. No battery is used with the oscillator. Consequently, every time the ACT truck is moved, the quartz oscillator must be restabilized and adjusted as shown by the VLF receiver.

C. Frequency Difference Meter. The Frequency Difference Meter (FDM), Hickok Model FDM 2100, is used to compare stable 100 kHz, 1 MHz, and 5.0 MHz sources to the ACT's quartz oscillator or other local standard. The FDM compares an unknown frequency standard with a reference frequency standard and indicates the difference. The FDM indication is a relative reading; therefore, the accuracy and stability of the reference must be considered in using the FDM. The comparison capability of the FDM is from 0 to ± 10 parts in 10^7 through 0 to ± 10 parts in 10^{11} (direct reading).

D. Omega Gating Unit. The Omega Gating Unit, Tracor Model 543, enables the VLF receiver to operate with the Omega navigation signals or with the standard VLF transmissions. Since Omega stations broadcast in 1-second bursts while time sharing the same frequency with the Omega stations, it is necessary to gate the VLF receiver ON only during the desired 1-second burst.

III. GENERAL TECHNIQUES

After arriving at a new location the calibration team will energize the frequency calibration system and align the antenna for maximum signal strength. After the desired VLF signal is located, the VLF receiver is used to monitor the warmup of the quartz oscillator. Fig. 2 shows an actual warmup of the Vectron Quartz

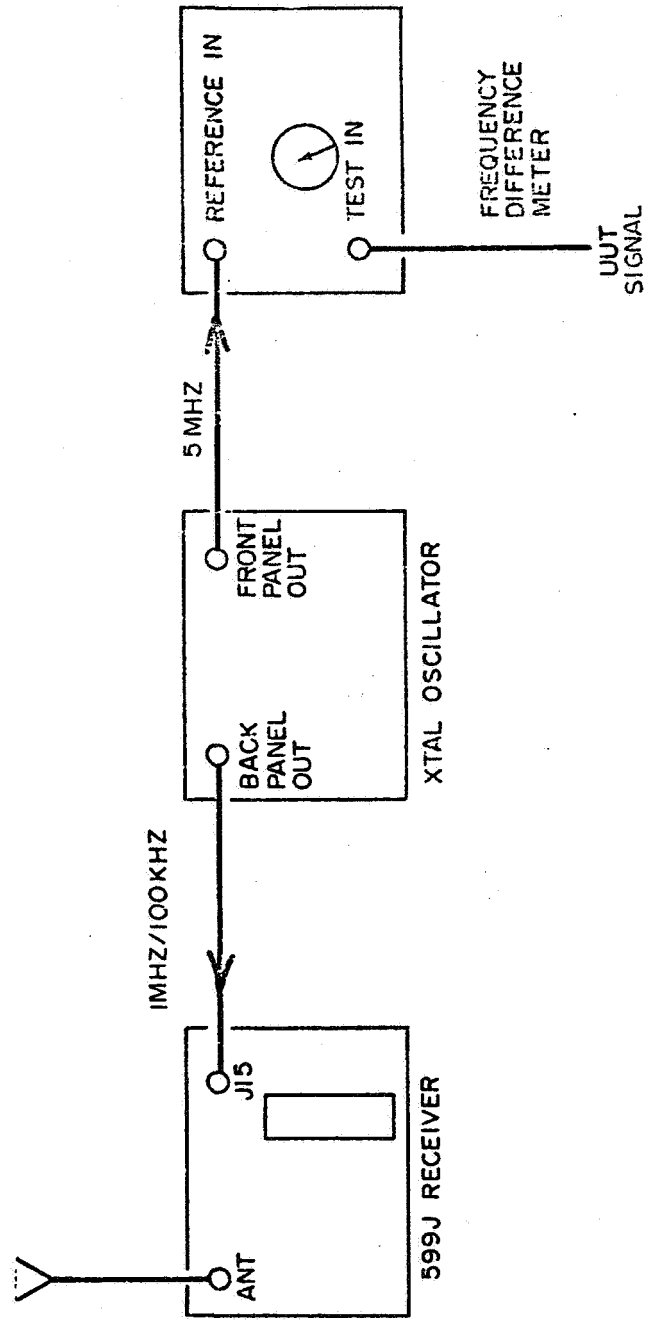

Fig. 1—Frequency calibration techniques

SECTION OF CHART PAPER FROM VLF RECEIVER
APN 7912766. FULL SCALE IS 100 μ SECONDS

CHART MOTION
↓

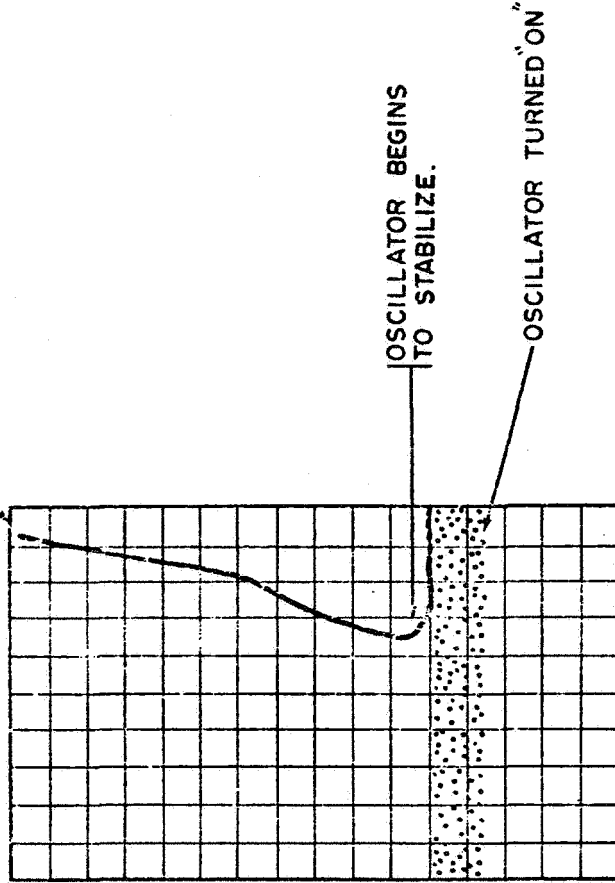

Fig. 2—Typical warmup drift of Quartz Oscillator, MIS-10223

ORIGINAL PAGE IS
OF POOR QUALITY

Oscillator following a 24-hour OFF period. Fig. 2 has been redrawn from the original strip chart. Note that each vertical segment represents 15 minutes.

Fig. 3 shows another warmup for the same oscillator also after 24 hours OFF, however, this time the frequency error is corrected. Thereafter, the operator monitors the VLF receiver and makes corrections as needed. The procedure, as shown, uses all daylight paths from the transmitter to the receiver site. In remote locations, obtaining a good DoD signal can be a problem if rapid set up of the quartz oscillator is desired.

After set up of the equipment, calibration is performed according to a Technical Bulletin step-by-step procedure for each test item. Typically a Technical Bulletin of 1968 vintage required adjustment of the time base oscillator to a minimum frequency difference with a standard oscillator by observing the drift rate on a CRT display. Having adjusted for a minimum frequency difference, calibration of the oscillator was considered complete. USAMCC has attempted to improve the calibration procedure for quartz oscillators while still keeping costs down to a reasonable level. Current procedure is outlined as follows:

- A. Warm up all oscillators to manufacturer's specifications.
- B. Set the time base oscillator to a minimum frequency difference with the standard oscillator. (As a rule of thumb we say adjust to a minimum frequency difference which is less than the daily stability specification.)
- C. After setting to a minimum frequency difference, monitor the oscillator's stability. To date, we have only implemented this change for 24-hour stability specifications.

USAMCC's present procedure is to observe those oscillators with 24-hour stability specifications of approximately ± 5.0 parts in 10^{10} per 24 hours for 24 hours and oscillators with specifications of approximately 3 parts in 10^9 per 24 hours, for 8 hours. A 24-hour stability is extrapolated from the 8-hour measurement. Stability specifications for weekly or monthly rates extend over too long an interval to allow ACT's to monitor a significant period. Extrapolation of 24-hour data in these cases is not recommended.

Short-term stabilities - for example, over a period of 1 second - are presently not being calibrated by USAMCC. Discussions with several manufacturers have shown little benefit to be expected from such a calibration at this time. Comments on the validity of not performing regular measurement of the short-term stability of quartz oscillators are of interest to USAMCC.

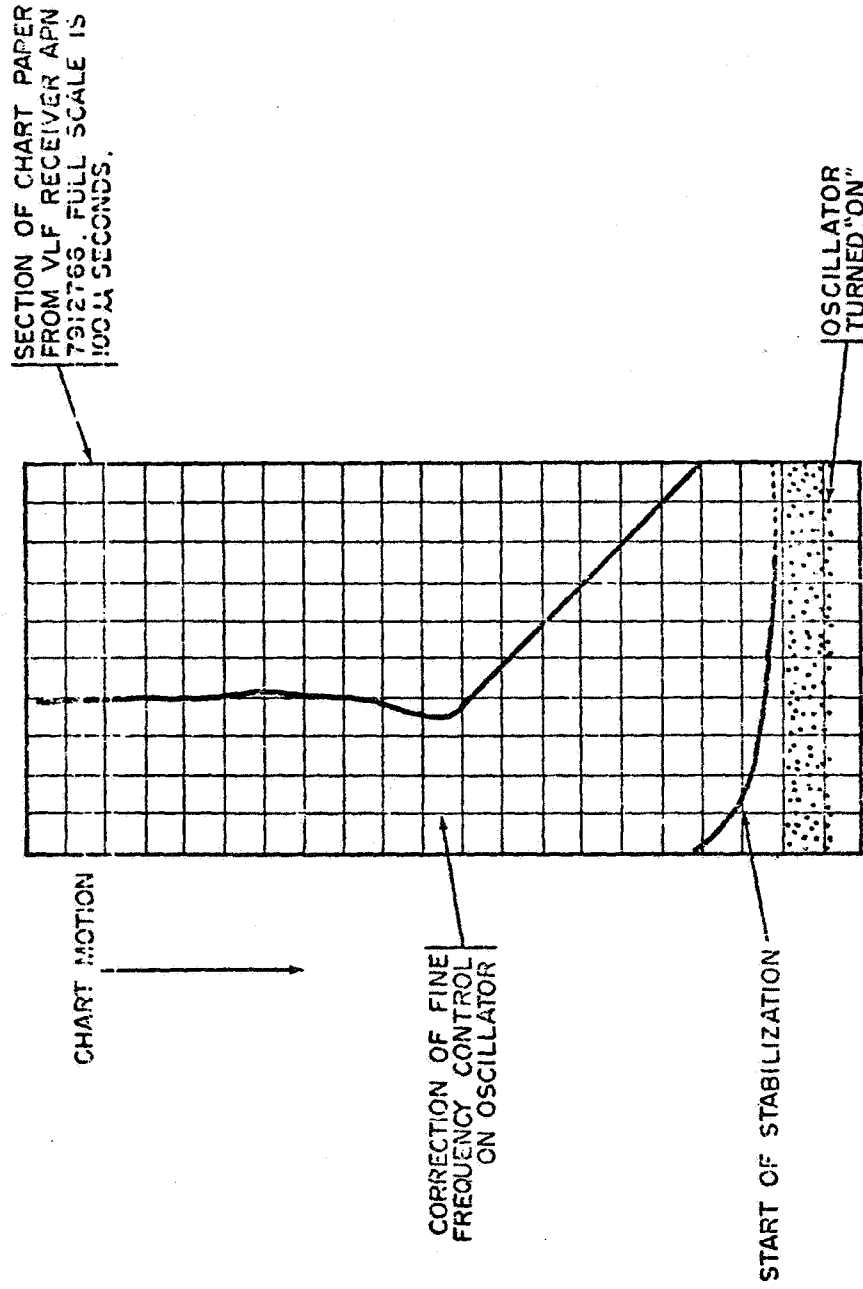

Fig. 3—Typical warmup drift of Quartz Oscillator, MIS-10223,
showing correction of frequency difference

At present, the Army Calibration System has made no significant changes to the calibration of air bath crystal oscillators. Tests have shown that frequency changes due to temperature variations under normal operating conditions exceed daily crystal long-term aging specifications. Discussions with one manufacturer showed that calibration of an air bath crystal temperature characteristics might be much more useful than any attempt to determine the long-term aging rate from observations over a relatively short time period at a fixed temperature. However, such a calibration of temperature characteristics would be expensive and probably achieve little real benefit in increased accuracy of the product.

The problem of characterizing the actual accuracy of quartz oscillators over an extended period requires historical data. As automation enables data keeping and analysis to reach affordable levels, we plan to keep records on the stability of instruments. At present each calibration is a separate entity with no data carried forward to the next calibration. Data keeping would particularly aid the customer to determine the expected accuracy of his equipment under field conditions and would give solid data on which to base calibration intervals.

Due to manpower and power restrictions, we have been asked to look into shortening the warmup time for oscillators prior to calibration. We plan to conduct testing during the next year on some high density frequency counters to determine if this shortened warmup can be used without undesirable effects on the required accuracy of the equipment the counters support.

IV. PROBLEMS

A. VLF Receiver. The VLF receiver has been generally reliable, both in terms of maintenance and operation. Some locations have had difficulty obtaining good quality DoD signals for a sufficient length of time. In Europe, for example, a full 8-hour workday is not available from a DoD signal which has an all daylight path - except for Omega. Due to these problems and other complaints, the Omega gating unit was added to the VLF receiver.

B. Omega Gating Unit. The Omega gating unit's main difficulty lies with synchronization. No VHF time signals are available, or any other source of time, except in those few cases where a calibration team is operated near an organization with access to a time signal such as a communications unit. Instead of time signals, the Omega gating unit is synchronized by ear. The advance or retard controls are manipulated as necessary to match the blinking light for the required time segment with the tone from the selected Omega station. It has been often necessary to utilize headphones and careful adjustment of the blanking on the receiver to find the Omega signal. The synchronization is performed with the VLF receiver ON all the time - not gated. After the Omega signal and the required

time segment are aligned, then the receiver is switched to the gated position and the phase track observed to determine if the receiver has locked on to the Omega signal. Reception of Omega is made more difficult by the noisiness of the reception. In fact, if one attempts to adjust the gating in the gated mode, the 1-second burst of noise is filtered by the receiver and sounds very similar to an Omega signal. Consequently, it is necessary to get an accurate identification of the Omega tone and not confuse it with noise.

C. Quartz Oscillator. The quartz crystal oscillator has performed well with one exception, that exception being an unexpectedly high failure rate due to crystal fracture. At one point over 5% of the 150 units fielded had suffered crystal fracture. No exact reason has been determined but part of the problem may lie with the physical shocks the oscillator unit absorbs in a mobile environment.

D. Antennas. The VLF receiver was originally supplied with a loop antenna which was effective - if somewhat cumbersome. The difficulties of antenna erection and storage, combined with new requirements which necessitated monitoring by the VLF receiver at locations outside the truck, made a more convenient antenna necessary. A ferrite core antenna was procured which utilizes a low noise amplifier to achieve the required sensitivity. The ferrite antenna has proven to be a very satisfactory unit with no significant failures. The unit is easily field mounted and in many good signal areas in the United States functions well setting on top of the receiver in unshielded locations.

E. Frequency Difference Meter.

The frequency difference meter has had excellent reliability. The zero center meter display of frequency difference has proven to be particularly well suited to adjusting one oscillator to match the frequency of another. The CRT display has proven to be of little benefit and requires periodic replacement due to burning of the phosphor.

An additional output of 25 kHz was obtained with the frequency difference meter produced for the Army Calibration System which is derived from the 5 MHz output of the local frequency standard. By attenuating the 25 kHz signal to a level approximating that of a typical RF signal (which would be present at the input to the VLF receiver) a system checkout can be easily performed which will give the user added confidence in his equipment (refer to Fig. 4). Since the VLF receiver is a phase tracking device, feeding a 25 kHz signal in the antenna connector and a 1 MHz signal in the reference oscillator input will yield a vertical track on the recorder chart when the signals are derived from the same oscillator.

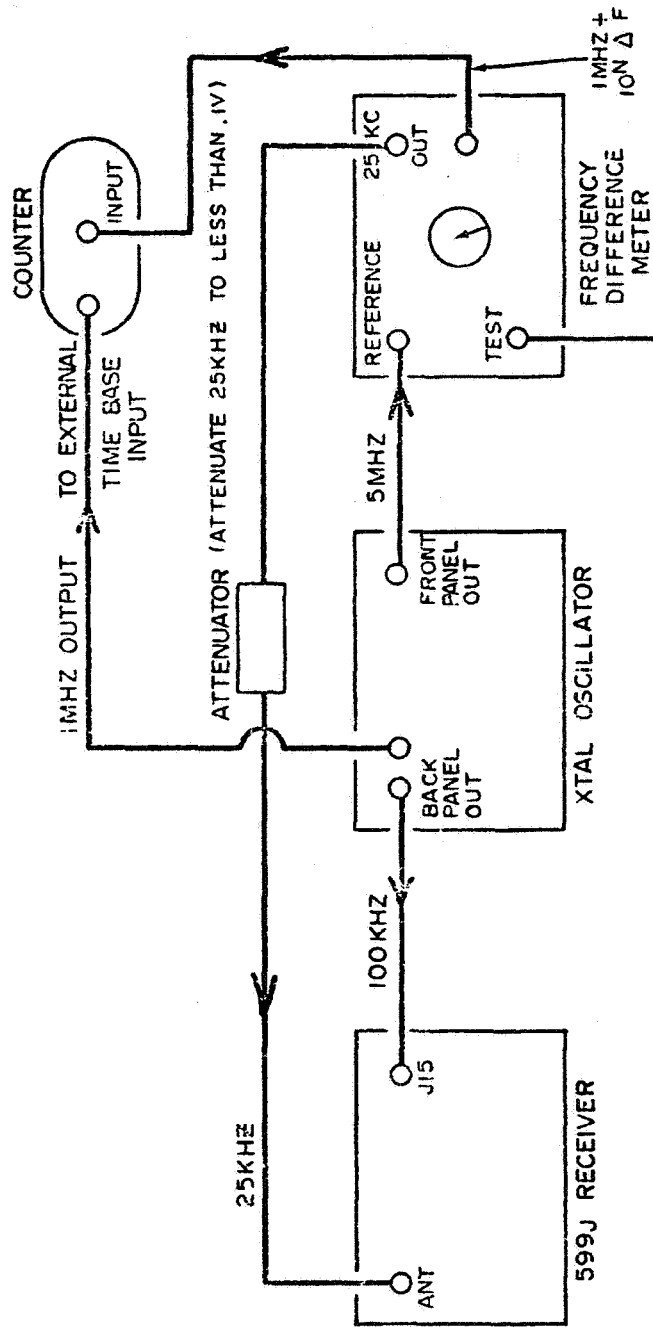

Fig. 4—System checkout for frequency calibration

If the ideal frequency difference meter were purchased now, it would have both a zero center meter for setting oscillators to a minimum frequency difference and a digital display for monitoring the stability of the oscillator under test.

V. SUMMARY

The system used by USAMCC has generally performed well and has thus far justified its selection over alternate techniques and systems. Reliance on VLF does require labor, setting up and operating the VLF receiver, making judgments on the displayed phase plot, and adjusting the quartz oscillator.