

DESIGN DEFINITION STUDY  
OF  
NASA/NAVY LIFT/CRUISE FAN V/STOL AIRCRAFT  
VOLUME I - SUMMARY REPORT OF  
NAVY MULTIMISSION AIRCRAFT

By Robert L. Cavage, et al

JULY 1975

Distribution of this report is provided in the interest of information exchange. Responsibility for the contents resides in the author or organization that prepared it.

Prepared under Contract No. NAS 2-6564 by  
ROCKWELL INTERNATIONAL CORPORATION  
Los Angeles, California  
FOR  
AMES RESEARCH CENTER  
NATIONAL AERONAUTICS AND SPACE ADMINISTRATION

DESIGN DEFINITION STUDY  
OF  
NASA/NAVY LIFT/CRUISE FAN V/STOL AIRCRAFT  
VOLUME I - SUMMARY REPORT OF NAVY MULTIMISSION AIRCRAFT  
by Robert L. Cavage, et al

SUMMARY

This report presents results of a study by the Rockwell International Corporation for the NASA Ames Research Center and the Naval Air Systems Command of promising Navy lift-cruise fan V/STOL aircraft for the 1980-1985 time period. The purpose of the study was to identify the likely technical and operating characteristics and technology requirements for the ultimate development of this type aircraft. The study focused on identifying aircraft individually optimized to perform the anti-submarine warfare, carrier onboard delivery, combat search and rescue, surveillance and surface attack missions, and a multi-purpose aircraft concept capable of performing all five missions at minimum total program cost. The selected multi-purpose configuration is shown below.

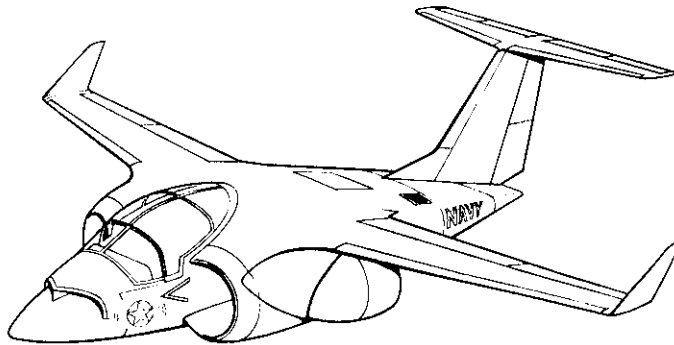

The configuration features the use of two 1.3 fan pressure ratio, single stage lift-cruise fans and three current design J97 gas generators with a high mounted high aspect ratio wing with winglets. The design missions can be performed at takeoff weights ranging from approximately 32,000 to 39,000 pounds. Top speed is 0.80 mach number at sea level and 0.885 at altitude. Advanced composite structural technology and advanced subsystem concepts are employed. One basic fuselage design, with alternate bolt-in floor structures, meets all the mission requirements.

## INTRODUCTION

Prior NASA sponsored studies have identified remote tip turbine driven lift-cruise fan V/STOL systems as having advantages for commercial and Navy carrier onboard delivery V/STOL transport missions for the 1980-1985 time period, References 1 through 3.

The purpose of this study was to investigate a broader range of lift-cruise fan Navy V/STOL applications for the 1980-1985 time period and to identify the likely aircraft characteristics and technology requirements.

An important guideline for the study was that the propulsion system should consist of a J97 gas generator (engine) and a lift-cruise fan using the same technology, and of approximately the same size, as the LF460 lift-cruise fan design of Reference 4. Because of the wide variety of design mission conditions to be accommodated, data on lift-cruise fans of compatible technology as described in Reference 5 were considered in the selection of optimum fans for the various study mission applications. All fan designs were to have a firm technology base consistent with a 1985 initial operational capability date.

The scope of the study included investigation and identification of optimum lift-cruise fan V/STOL aircraft for each of five separate Navy mission applications and identification of a single compromise multi-purpose aircraft capable of performing all missions or the cost-effective portion of them. To validate the aircraft characteristics relative to specific, low speed hover control characteristics, low speed safety and handling characteristics were evaluated. Lift and drag buildup data were prepared. Mass properties and structural concepts appropriate to structural technology providing up to a 15 percent structural weight saving relative to current state-of-the-art all metal technology were defined. Appropriate avionics suit complements for each mission and advanced state-of-the-art aircraft subsystem concepts were also identified. Selected trade studies were made to identify the most appropriate vehicle characteristics including propulsion system arrangement, fuselage, wing and tail design parameters.

The study identified that the technology developable by the early 1980's could provide a very attractive Navy lift-cruise fan V/STOL multi-purpose aircraft. The study also showed, that if the importance of individual missions could justify it, lighter and smaller aircraft could be obtained by optimizing the design and fan selection for specific missions.

CONTENTS

	<u>PAGE</u>
SUMMARY . . . . .	iii
INTRODUCTION. . . . .	iv
CONTENTS . . . . .	v
SYMBOLS . . . . .	vi
ILLUSTRATIONS . . . . .	xi
TABLES . . . . .	xii
STUDY GUIDELINES. . . . .	1
MULTI-MISSION AIRCRAFT CONFIGURATION. . . . .	3
CONCEPT DEFINITION . . . . .	3
PERFORMANCE. . . . .	8
PROPULSION/HOVER CONTROL . . . . .	16
AERODYNAMICS & LOW SPEED CHARACTERISTICS . . . . .	21
STRUCTURE. . . . .	27
SUBSYSTEMS . . . . .	28
MASS PROPERTIES. . . . .	30
OPTIMIZED PRELIMINARY CONCEPTUAL AIRCRAFT . . . . .	33
ANTI-SUBMARINE WARFARE (ASW) AIRCRAFT. . . . .	33
VERTICAL ONBOARD DELIVERY (VOD) AIRCRAFT . . . . .	34
COMBAT SEARCH AND RESCUE (CSAR) AIRCRAFT . . . . .	35
SURVEILLANCE (SURV) AIRCRAFT . . . . .	37
SURFACE ATTACK (SA) AIRCRAFT . . . . .	38
PROPULSION TECHNOLOGY . . . . .	40
GAS GENERATOR. . . . .	40
LIFT CRUISE FANS . . . . .	41
TRADE STUDIES . . . . .	44
CONCLUSIONS . . . . .	63
REFERENCES . . . . .	64

## SYMBOLS

APU	Auxiliary Power Unit
AR	Aspect Ratio
ASW	Anti-Submarine Warfare
b	Span, Ft (0.3048 meters)
BCAV	Best Cruise Altitude and Velocity
$C_{D_o}$	Parasite Drag Coefficient
$C_{D_L}$	Drag Due to Lift
CG	Center of Gravity
$C_L$	Lift Coefficient, L/qs
$C_{L_{max}}$	Maximum Lift Coefficient, L/qs
CSAR	Combat Search and Rescue
DIA	Diameter, In. (0.0254 meters)
DIST	Distance
e	Span Efficiency Factor
ECS	Environmental Control System
ETC	Energy Transfer Control
EXP	Exposed
FPR	Fan Pressure Ratio
FPS	Feet Per Second (0.3048 meters/second)
FPM	Feet Per Minute (0.00508 meters/second)
g, G	Acceleration of Gravity, 32.2 ft/sec <sup>2</sup> (9.815 m/sec <sup>2</sup> )

## SYMBOLS

H <sub>2</sub> O	Water
GE	General Electric Company
GG	Gas Generator
°F	Temperature in Fahrenheit, Degrees (5/9 (°F+459.67))°K
GPM	Gallons Per Minute (0.00006309 meters <sup>3</sup> /sec)
h	Altitude, Ft (0.3048 meters)
HP	Horsepower
KEAS	Knots Equivalent Air Speed, Knots (0.5144 meters/sec)
KN, KTS	Knot(s) (0.5144 meters/sec)
KVA	Kilovolt Ampere(s)
L	Lift, Lb (4.44822 Newtons)
L/C	Lift-Cruise
L/D	Lift-To-Drag Ratio
L <sub>MAX</sub>	Maximum Lift Per Fan During Maximum Up Control
L <sub>NOM</sub>	Nominal Lift Per Fan at Neutral Control at Military Power Setting of Gas Generator
L <sub>NOM 1 MIN VTO</sub>	Nominal Lift Per Fan at Neutral Control at One Minute Vertical Takeoff Rating of Gas Generator
M	Mach Number
MAC	Mean Aerodynamic Chord
MAX	Maximum
n	Normal Load Factor
N MI	Nautical Mile(s) (1852 meters)

## SYMBOLS

NOM	Nominal
NRP	Normal Rated Power
P/L	Payload, Lb (4.44822 Newtons)
PR	Pressure Ratio
PSI	Pounds per Square Inch, lb/in <sup>2</sup> (6894.75478 Newtons/m <sup>2</sup> )
PSF	Pounds per Square Foot, lb/ft <sup>2</sup> (47.88024159 Newtons/m <sup>2</sup> )
PWR	Power
q	Dynamic Pressure, lb/ft <sup>2</sup> (47.88024159 Newtons/m <sup>2</sup> )
REF	Reference
RPM	Revolutions Per Minute (0.016666 Rev/Sec)
SEC	Second(s)
S, S <sub>W</sub>	Wing Area, Ft <sup>2</sup> (0.09290304 meters <sup>2</sup> )
SA	Surface Attack
SFC	Specific Fuel Consumption, LB MASS FUEL/HR/LB THRUST (0.000028325 Kg Fuel/Sec/Newton Thrust)
SL	Sea Level
SLS	Sea Level Static
STOGW	Short Takeoff Gross Weight, LB (4.44822 Newtons)
STOL	Short Takeoff and Landing
SURV	Surveillance
T	Thrust, LB (4.44822 Newtons)
t/c	Thickness to Chord Ratio, %

## SYMBOLS

T.O.	Takeoff
TOGW	Takeoff Gross Weight, LB (4.44822 Newtons)
T/W	Thrust-to-Weight Ratio
V-LDG	Vertical Landing
V/STOL	Vertical/Short Takeoff and Landing
$V_S$	Stall Velocity, Knots (0.51444 meters/second)
VOD	Vertical Onboard Delivery
VTO	Vertical Takeoff
VTOGW	Vertical Takeoff Gross Weight, LB (4.44822 Newtons)
W/O	Without
WOD	Wind Over Deck
W/S	Wing Loading, lb/ft <sup>2</sup> (47.88024159 Newtons/m <sup>2</sup> )
WT, W	Weight LB (4.44822 Newtons)
W/Wo	Ratio of Individual Weight Item to Takeoff Weight
$\alpha$	Angle-of-Attack, Degrees (0.017453 radians)
$\Delta$	Increment, or Incremental
$\delta_F$	Flap Deflection Angle, Degrees (0.017453 radians)
$\Delta C_D$	Incremental Drag Coefficient
$\Delta L_i$	Interference Lift Due to Power, Lb (4.44882 Newtons)
$\gamma$	Flight Path Angle, Degrees (0.017453 radians)
$\gamma_{MAX}$	Maximum Flight Path Angle, Degrees (0.017453 radians)
$\Lambda_c/4$	Sweep Angle of Quarter Chord Line, Degrees (0.017453 radians)



SYMBOLS

$\Lambda_{LE}$	Leading Edge Sweep Angle, Degrees (0.017453 Radians)
$\lambda$	Taper Ratio, Tip Chord to Root Chord
$\phi_1$	Bank Angle, After 1 Second, Degrees (0.017453 radians)
$\theta_1$	Pitch Angle After 1 Second, Degrees (0.017453 radians)
$\psi_1$	Yaw Angle After 1 Second, Degrees (0.017453 radians)

## ILLUSTRATIONS

Figure	Title	Page
1	Major Mission & Vehicle Design Criteria . . . . .	2
2	Multi-Mission Aircraft Configuration. . . . .	3
3	Fuselage Cross-Section Concept. . . . .	5
4	Fuselage Internal Arrangement vs Mission. . . . .	6
5	Lift-Fan Multi-Mission Aircraft Vision Characteristics. . . . .	7
6	Multi-Mission Aircraft Spotting Comparison With A-7 . . . . .	8
7	Basic ASW Mission Performance . . . . .	9
8	Basic VOD Mission Performance . . . . .	10
9	Basic CSAR Mission Performance. . . . .	11
10	Basic Surveillance Mission Performance. . . . .	12
11	Basic Surface Attack Mission Performance. . . . .	13
12	Multi-Mission Aircraft Speed-Altitude Capability. . . . .	14
13	Multi-Mission Aircraft Takeoff Performance. . . . .	15
14	Basic Lift-Cruise Fan System Installation . . . . .	16
15	Complete Propulsion/Hover Control System Installation . . . . .	17
16	Hover and VTOL Operation Lift Capabilities. . . . .	19
17	Hover Control Power - VOD Emergency Landing . . . . .	20
18	Trimmed L/D vs. Lift Coefficient. . . . .	21
19	Low Speed Power Off Drag Polars . . . . .	22
20	Low Speed Propulsion/Aerodynamic Interaction Characteristics	22
21	Normal Roll Attitude Angle Attained in One Second . . . . .	24
22	Emergency Roll Attitude Angle Attained in One Second . . . . .	24
23	Normal Pitch Attitude Angle Attained in One Second . . . . .	25
24	Emergency Pitch Attitude Angle Attained in One Second. . . . .	25
25	Normal Yaw Attitude Angle Attained in One Second . . . . .	26
26	Emergency Yaw Attitude Angle Attained in One Second . . . . .	26
27	Center of Gravity Travel and Inertia Characteristics by Mission	32
28	Optimized ASW Aircraft Design Brief . . . . .	34
29	Optimized VOD Aircraft Design Brief . . . . .	35
30	Optimized CSAR Aircraft Design Brief . . . . .	36
31	Optimized Surveillance Design Brief . . . . .	37
32	Optimized Surface Attack Design Brief . . . . .	38
33	J97-GE-100 Gas Generator Characteristics . . . . .	41
34	Typical Single and Two-Stage Military Lift Cruise Fans . . . . .	42
35	J97 Energy Transfer Control Characteristics. . . . .	43
36	Two and Three Fan Config. VTOL Reingestion Characteristics . . . . .	46
37	Loiter SFC Comparison - One vs. Two Gas Generators. . . . .	49
38	Static Thrust of Propulsion Systems vs. Design FPR . . . . .	50
39	Takeoff and Cruise Thrust to Weight Ratio Characteristics of Lift-Cruise Fan Systems . . . . .	51
40	Lift-Fan System Cruise SFC Characteristics . . . . .	51
41	Fan Tip Diameter vs. Fan Type and Design FPR . . . . .	52
42	Two Fan/Two Gas Generator Multi-Purpose Aircraft Concept - No VOD Requirements . . . . .	.54

ILLUSTRATIONS (CONCLUDED)

Figure	Title	Page
43	Aircraft TOGW Sensitivity to Major Design Parameters. . . . .	55
44	Estimated Potential Winglet Design & Performance Characteristics	58
45	Candidate Fuselage Cross-Section Designs. . . . .	59
46	Summary of Empennage Design Trade Study . . . . .	60

TABLES

Table		Page
1	Wing and Tail Surface Geometry. . . . .	4
2	Lift-Cruise Fan System VTO Thrust Ratings . . . . .	18
3	Summary of Major Group Weight Fractions By Mission. . . . .	30
4	Group Weight Summaries By Mission Configuration . . . . .	31
5	Comparison of J97 and J101 Propulsion System Uninstalled Characteristics . . . . .	40
6	Two Fan Vs. Three Fan Configuration Comparison . . . . .	45
7	Summary of TOGW sensitivity to Design Parameters . . . . .	56

## STUDY GUIDELINES

The study guidelines were provided through agreements reached by the NASA and Naval Air Systems Command study monitors with selected inputs from the contractor. The major elements were the individual mission payload and profile criteria, low speed control and handling criteria and specific air vehicle design criteria. Figure 1 summarizes the major mission and vehicle design criteria specified to direct the study.

The performance on each of the mission profiles shown on figure 1 is calculated for standard day conditions and also requires a 5% increase in fuel flow plus a 5% initial fuel reserve. The specified mission payloads indicate installation, weight and volume requirements as appropriate for the payload indicated. The payload weight figures given with the individual missions include the weight of the crew and avionics as well as the other specialized payload items. The specialized avionics identified in the guidelines for the ASW and surveillance missions are not identified in the report because of their current classified status.

During the study, it was determined that a level of composite material technology allowing a 15 percent weight saving relative to current state-of-the-art all metal technology could be justified on a cost-effective basis for the projected applications.

In addition to the study guideline items illustrated in figure 1, an extensive set of flight safety and low speed operating criteria were specified for the study aircraft to assure satisfactory operating characteristics. These criteria included:

- Attitude Control Power
- Flight Path Control Power
- VTOL & STOL Low Speed Control System Response Time
- Hovering, Low Speed & Cruise Stability
- STOL Takeoff Safety Requirements
- STOL and VTOL Conversion Requirements

Criteria of the above types were specified for both normal and failure operating modes. With respect to propulsion system failures, only gas generator failures were addressed. The technology expected to be available for lift-fans in the early 1980's is expected to provide fan reliabilities that indicate fan failures would be extremely rare. Single failures of any major control system element were considered. The design criteria provided adequate low speed margins to handle the large angle of attack changes due to gusts encountered when flying at very low speeds. These included the requirement for transition speeds of  $> 120\%$  of wing borne stall speed and maximum operational  $C_{L_{max}}$  of 0.8 of the maximum available  $C_{L_{max}}$ .

MISSION		PROFILE
ASW CREW -4	10 MIN LOITER	P/L -7140 LB (INCL CREW & AVIONICS) 4 HR LOITER @ 10,000 FT 150 N. MI.
SURVEILLANCE CREW-4	10 MIN LOITER	P/L-4355 LB 4 HR LOITER @25,000 FT 75 N. MI.
SURFACE ATTACK CREW - 3	10 MIN LOITER	P/L-4595 LB 2 HR LOITER @ 20,000 FT +5 MIN COMBAT 300 N. MI
COMBAT SEARCH & RESCUE CREW - 4	10 MIN LOITER	P/L-3180 LB 20 MIN LOITER @ 20,000 FT. 50 N. MI. SL DASH (.8M) 10 MIN HOVER (2 MAN PICKUP) 400 N. MI.
VERTICAL ON-BOARD DELIVERY CREW -3		P/L-6165 LB 20 MIN LOITER 2000 N. MI

- Mission Payloads:

- ASW - (2) MK-46 torpedoes plus 50 sonobuoys
- SURV - Specified avionics
- SA - (2) Harpoon missiles and (2) AIM-9 missiles
- CSAR - (2) AIM-9 missiles, mini-gun, ammo and armor
- VOD - 5000 pound cargo, TF-30, TF-34 or F401 engines on stand, 350" rotor blade, 17-23 passengers
- T.O. allowance 2.0 min intermed pwr + 0.5 min at max pwr
- 0.065g horizontal acceleration at liftoff, all engines oper
- VOD mission T.O. gnd dist of 450 ft with 20 Knots WOD, 90°F
- Other missions T.O. gnd dist of 400 ft with 10 Knots WOD, 90°F
- 500 fpm rate of climb at engine out best climb speed
- Emerg vertical landing T/W=1.0, 1000 lb fuel, 15 fps max sink, 90°F
- CSAR structure +5g,-1g; other structure +3g,-1g
- Maximum design gross weight 1.1 times max operational weight
- 15 fps maximum design sink speed
- Weight savings >10% with adv composite mat'ls with adequate cost justification
- Specified avionics for ASW and Surveillance missions
- Vehicle size compatible with 34 x 50 ft elevator; 19 ft max tail height
- Visibility better than the Harrier

Figure 1. Major Mission & Vehicle Design Criteria

## MULTI-MISSION AIRCRAFT CONFIGURATION

Based on the results of design evaluations of features identified as optimum for each of the five design missions and trade studies as identified in later sections of the report, a compromise multi-mission aircraft configuration was selected.

### Concept Definition

Figure 2 illustrates the major features of the selected multi-mission aircraft concept. The features selected allow meeting of the mission requirements with takeoff weights from 32,000 to 39,000 pounds. Different equipment, fuel and payloads are carried to adapt the basic airframe to each of the individual missions.

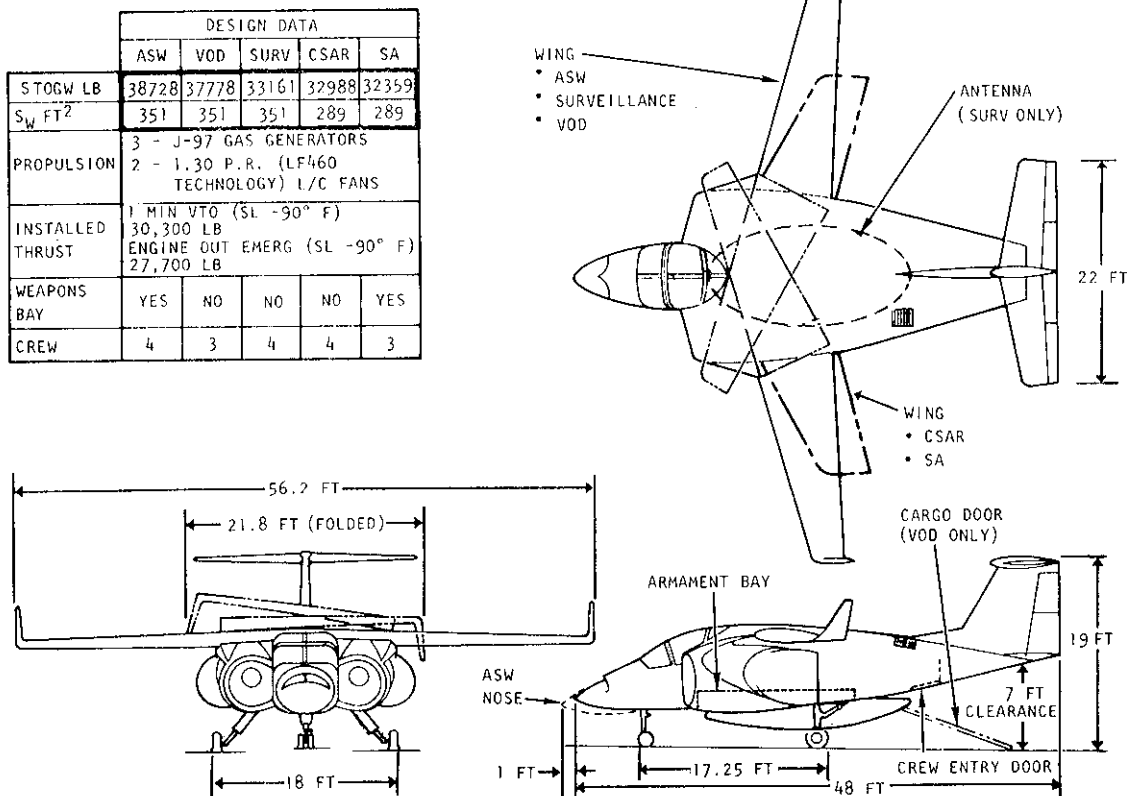

Figure 2. Multi-Mission Aircraft Configuration

The configuration features highly integrated propulsion/airframe components to minimize vehicle weight, drag and other penalties for the multi-mission application. Propulsion consists of two lift-cruise fans with lightweight integrated single swivel nozzles and three J97-GE-100 gas generators. The fans with their exhaust ducts and nozzles are nestled into the fuselage/wing junctures to minimize wetted area. The gas generators are

buried wholly within the moldlines of the fuselage. Two alternate outer wing panels are provided to adapt the configuration to all five design mission requirements. The wings are high mounted, high aspect ratio supercritical wings with increased effective aspect ratio through the use of emerging NASA winglet technology. With full span double slotted Fowler flaps, the wings provide high aerodynamic lift efficiency in both the cruise and low speed operating modes. The high aspect ratio wing approach was made practical through the use of advanced composite material technology allowing a 15 percent weight saving relative to current all metal state-of-the-art.

Provisions and structure are included in the design for two wet station external store locations on the bottom of the fuselage outboard of the weapon bay doors and sonobuoy dispensers. These stations can each handle 1300 pounds of stores or a 150 gallon fuel tank.

The configuration has wide tread landing gear which will provide good deck contact stability for small carrier and air capable ship operations.

A unique bottom mounted antenna design is incorporated into the surveillance mission version of the multi-mission airplane. The antenna provides the radar resolution performance equal to a 20-foot round rotodome installation at significantly lighter weight, lower drag and without any blockage by air vehicle components because of its lower surface installation. Similarly, because of its underneath location, it does not interfere with the wing fold design or operation and does not interfere with efficient emergency ejection of any of the crew members.

The major geometric features of the lifting surfaces of the vehicle are presented in Table 1. The winglets used on both wings each have a plan area each of 6.5 ft<sup>2</sup> and a height of 3.92 ft.

TABLE 1. WING AND TAIL SURFACE GEOMETRY

	ASN, VOD, SURV AR=9 WING	CSAR, SA AR=6.0 WING	HORIZ. TAIL	VERT. TAIL
S - ft	351	289	100	87.5
AR	9.0	6.0	4.84	2.37
$\lambda$	0.3	0.3	0.62	0.50
b - ft	56.2	41.64	22	10
$\Lambda_{c/4}$ - deg	12.9°	27.0°	8.2°	23.75°
t/c - %	17	17	10	10
Airfoil	Supercrit	Supercrit	64A010	64A010

The fuselage maximum length is 44.83 ft for all aircraft except the ASW; the ASW fuselage length is 45.83 ft because of a larger nose radome. The maximum fuselage height is 8.33 ft and the maximum width, including the fairings behind the fans but not the nozzles, is 17.67 ft. The maximum width, including the nozzles is 19.17 ft. The total wetted area of the ASW configuration is 2172 ft<sup>2</sup>, the VOD wetted area is 2159 ft<sup>2</sup>, the Surveillance wetted area is 2335 ft<sup>2</sup> and the wetted area of the CSAR and SA aircraft is 2036 ft<sup>2</sup>.

A major feature of the multi-mission configuration is that a single basic fuselage shape is employed to satisfy all mission requirements. Within this basic shape, two alternate bolt-in bottoms adapt the configuration to all five mission requirements as shown in figures 3 and 4. Figure 3

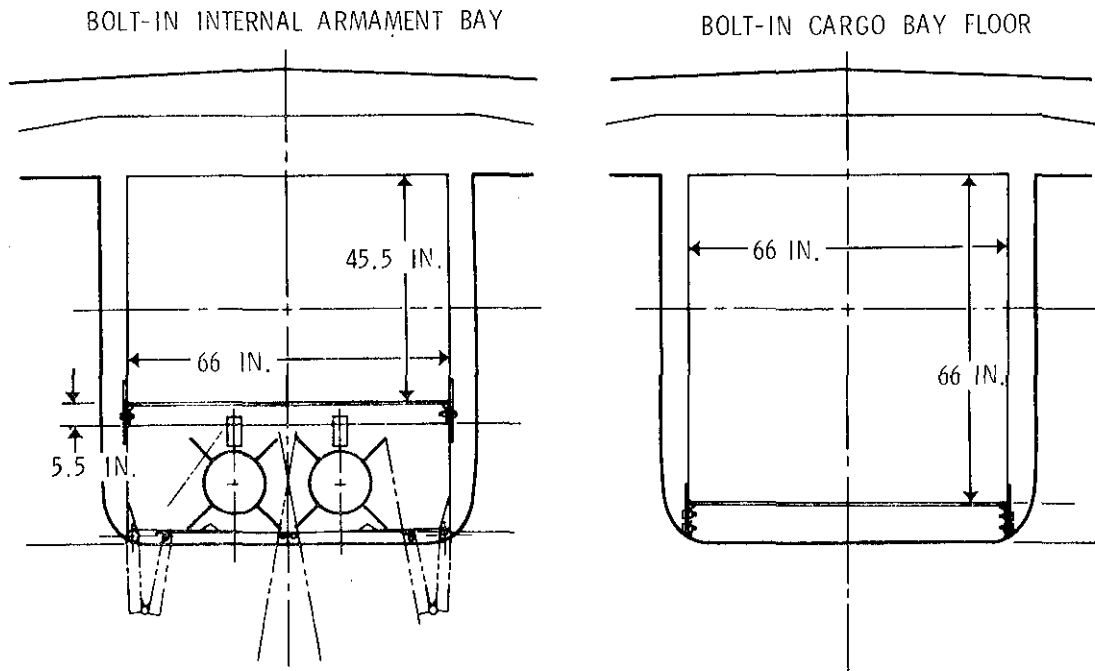

Figure 3. Fuselage Cross-Section Concept

shows how the two alternate bolt-in bottoms fit within the same basic fuselage shape and structure. The width of the central fuselage cavity is established by the VOD mission requirement to carry the TF-30 engine on its shipping stand. Similarly, a 66 inch cargo bay height is also established by the TF-30 on stand requirement. In addition to the VOD mission, the Surveillance and CSAR mission requirements can make good use of the 66 by 66 inch cargo bay cross-section cavity. Because both the ASW and the SA



mission have significant weapon carriage requirements, an alternate bolt-in bottom is provided with provisions for an internal armament bay. The internal fuselage volume requirements are not as critical as for the other missions, thus the space is more efficiently used by providing an internal

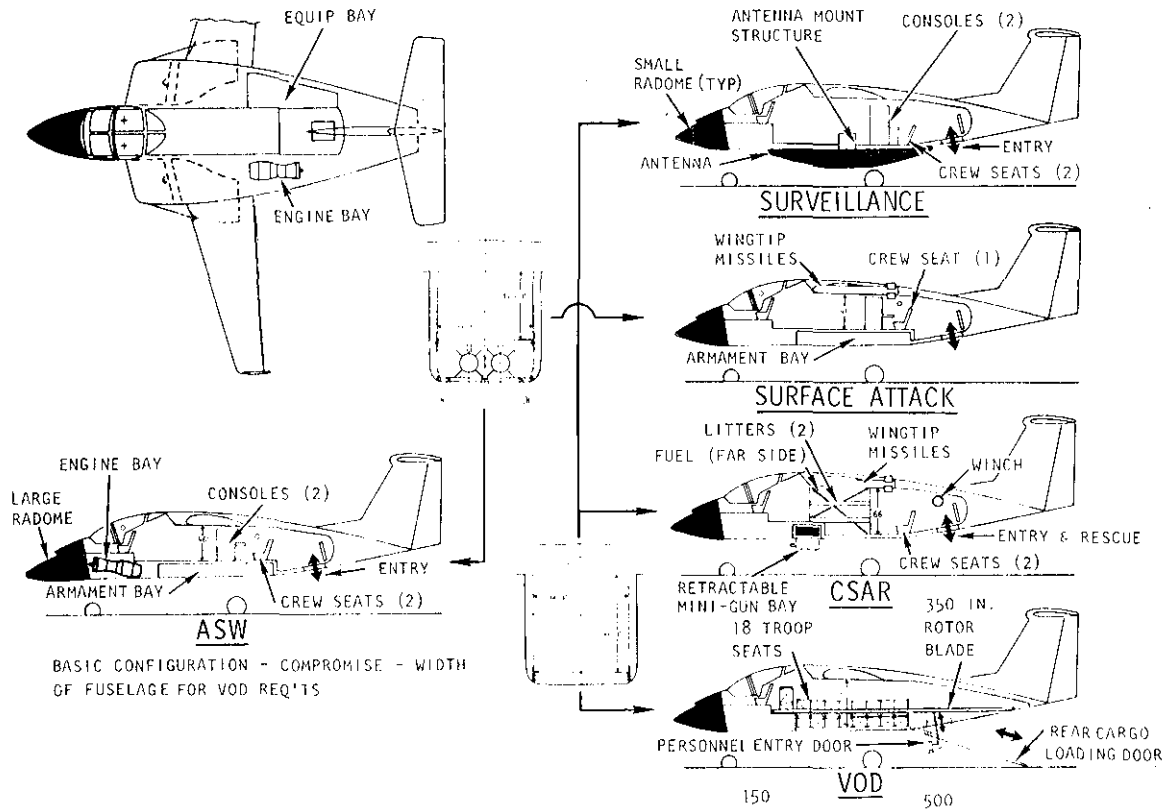

Figure 4. Fuselage Internal Arrangement vs Mission

armament bay which reduces drag and provides a more controllable environment for the carriage of torpedoes and missiles which must be provided specific temperature environments. The alternate bolt-in bottoms would be installed during fuselage assembly and, because of the identical outer moldlines, it is likely that a single assembly line would service the fuselages for all aircraft. A high degree of fuselage commonality is retained by this approach because the majority of the fuselage structure, wiring and systems routings can be made common. Only the lower portion of the fuselage frames carry small weight penalties to accommodate the alternate bolt-in bottoms.

The forward fuselage and cockpit design provide excellent visibility as shown by figure 5. The arrangement provides 20 degrees over the nose

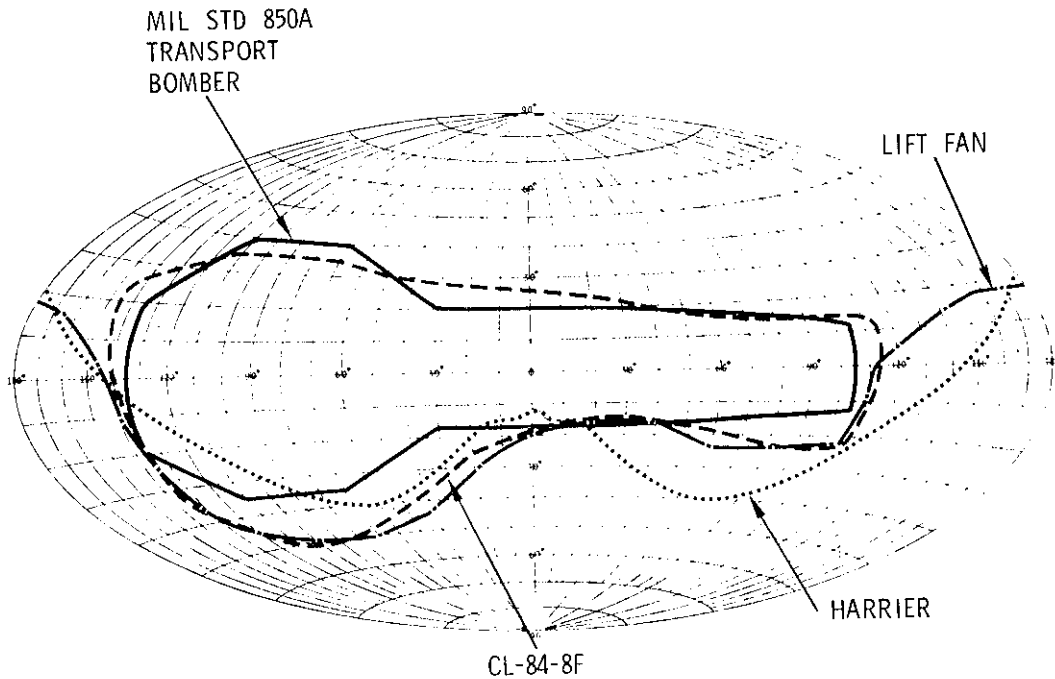

Figure 5. Lift-Fan Multi-Mission Aircraft Vision Characteristics

vision directly in front of the pilot which is better than the operational Harrier. In general, the vision is as good or better than the CL-84 aircraft which has been rated as good by many pilots.

In addition to the good visibility, the forward fuselage design provides an ample space for nose radar installations under the gas generator inlets. The larger nose radar requirement of the ASW aircraft can be handled as easily as the lesser requirements of the other missions.

Because of the high wing position, an over the top wing fold technique is possible which allows very compact stowage and spotting as illustrated by figure 6. The illustration of figure 6 shows the folded dimensions with the aspect ratio 9.0 wing. The folded span with the aspect ratio 6.0 wing is set by the width of the airplane between the outer extremities of the nozzle and is 21.67 feet.

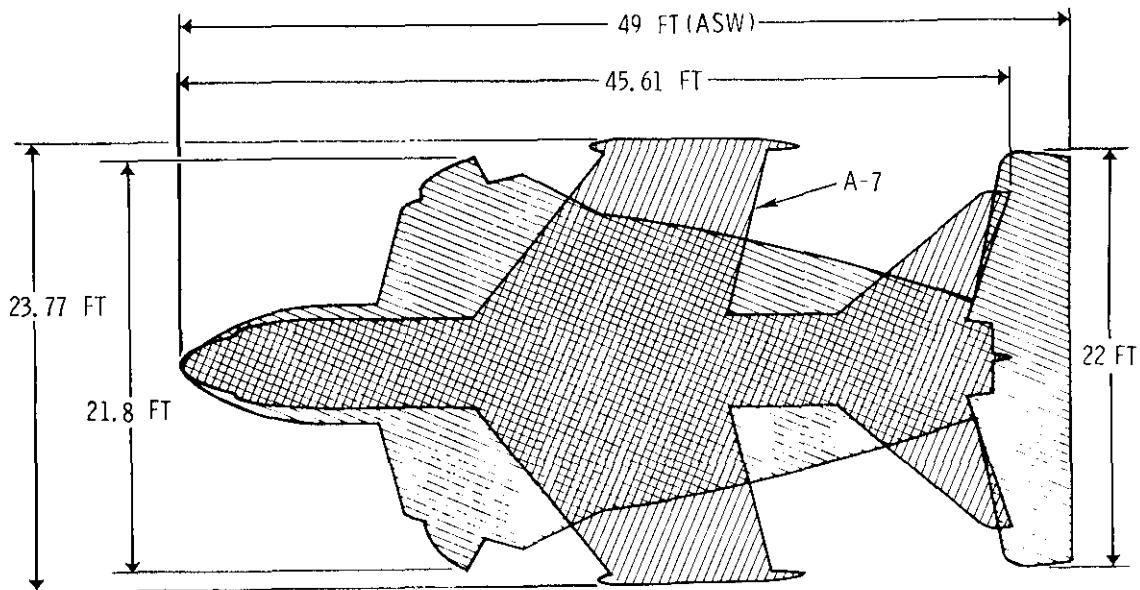

Figure 6. Multi-Mission Aircraft Spotting Comparison With A-7

Because of the high wing and high horizontal tail, there is opportunity for over-under nesting of parked aircraft and also good characteristics relative to providing for deck level foot and vehicle traffic around parked aircraft.

#### Performance

The fuel loads required for individual versions of the multi-mission aircraft were identified that allow completion of the individually specified missions. The inherent capability of the vehicle allows employment, however, in alternate mission profile applications where speed can be traded for range, loiter time, etc. and vice versa. This section presents the basic performance of the alternate mission versions on their respective design missions and discusses selected alternate capabilities that result from the basic capability.

The performance of the ASW version of the aircraft on the design ASW mission is presented in figure 7. The sum of non-expendable and expendable payload, crew and avionics totals to 7,140 pounds of mission oriented useful load for this mission. This represents the highest mission payload

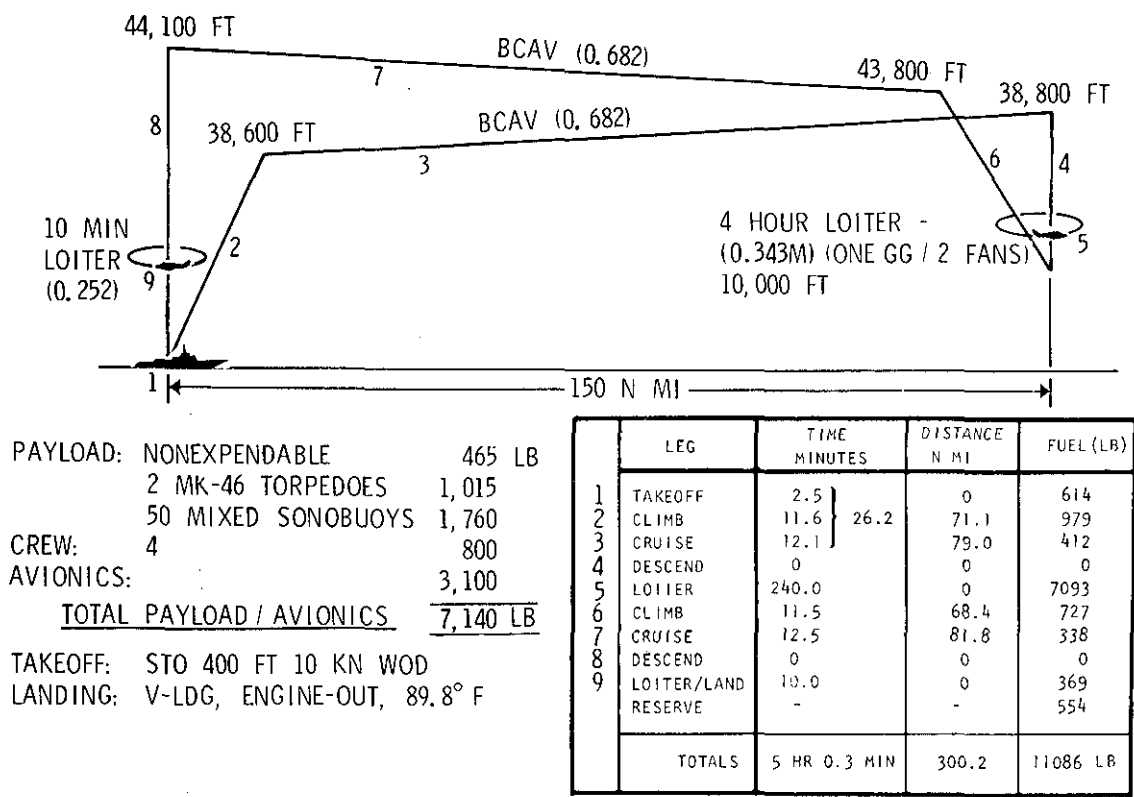

Figure 7. Basic ASW Mission Performance

requirement of all the design missions. Using the aspect ratio 9.0 wing, the optimum cruise mach number is 0.682 which is set by the wing drag divergence characteristics. This speed is sufficient for the ASW airplane to arrive on its station 150 nautical miles from the takeoff point in 26.2 minutes. The 4 hour design mission loiter is conducted at a speed of 200 knots at 10,000 feet at the 150 nautical mile radius point. The loiter fuel requirement is minimized by the aircraft's ability to loiter with one gas generator driving two fans. Alternately, the vehicle could loiter for one hour and 36 minutes at a 600 nautical mile radius point. Also, the loiter fuel allowance would allow a 3.5 hour sea level loiter at the 150 nautical mile radius point if desired. Loitering at 250 knots at 10,000 feet instead of 200 knots would reduce the loiter time to 3.6 hours.

The performance of the VOD version of the multi-mission aircraft is shown in figure 8. Since the same wing is used on the VOD as on the ASW mission, the optimum speeds and altitudes are very similar. The cruise speed allows a delivery to be made in 5.5 hours at the design distance of

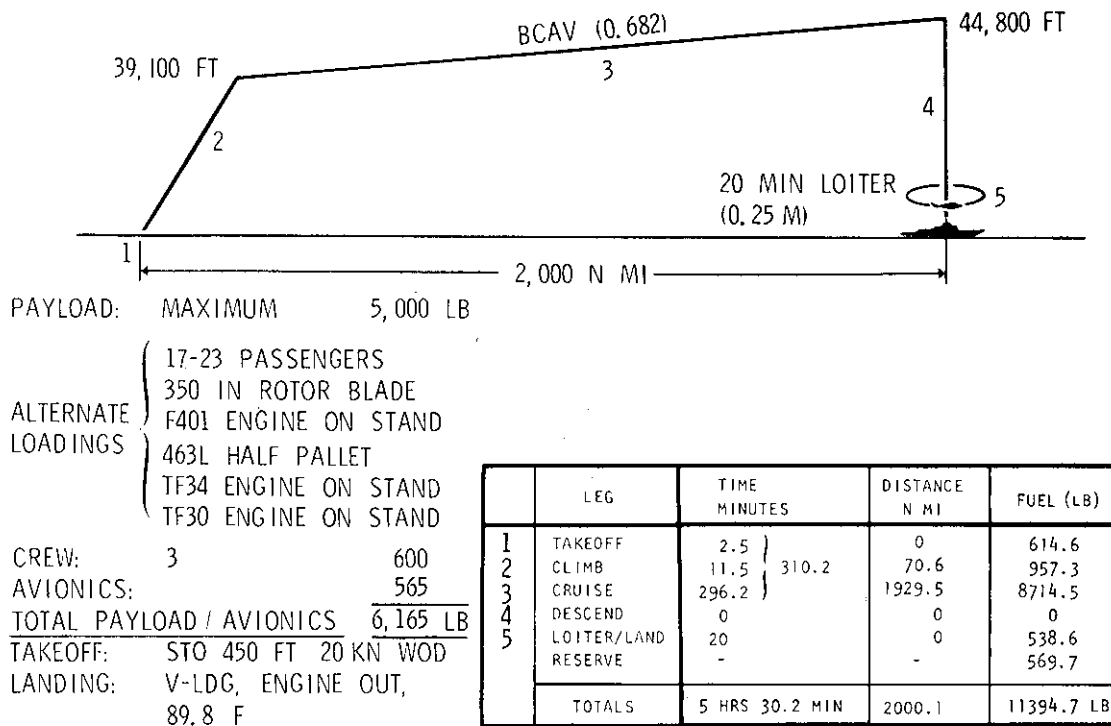

Figure 8. Basic VOD Mission Performance

2000 nautical miles. The reduction in avionics requirements allows a 5000 pound cargo payload to be carried within a total mission useful load of almost 1000 pounds less than required for the ASW mission. The aircraft can carry 17 seated troops in addition to its basic crew of three and cargo items including a 350 inch long rotor blade and a variety of pallets and engines on stands including the TF-30, TF-34 and F401.

The CSAR version of the multi-mission aircraft uses the aspect ratio 6.0 wing with 31 degrees of leading edge sweepback, hence it provides the vehicle with a higher overall drag divergence mach number and higher speed capability. The basic performance on the CSAR mission is shown in figure 9. The high cruise speeds indicated would allow this version of the

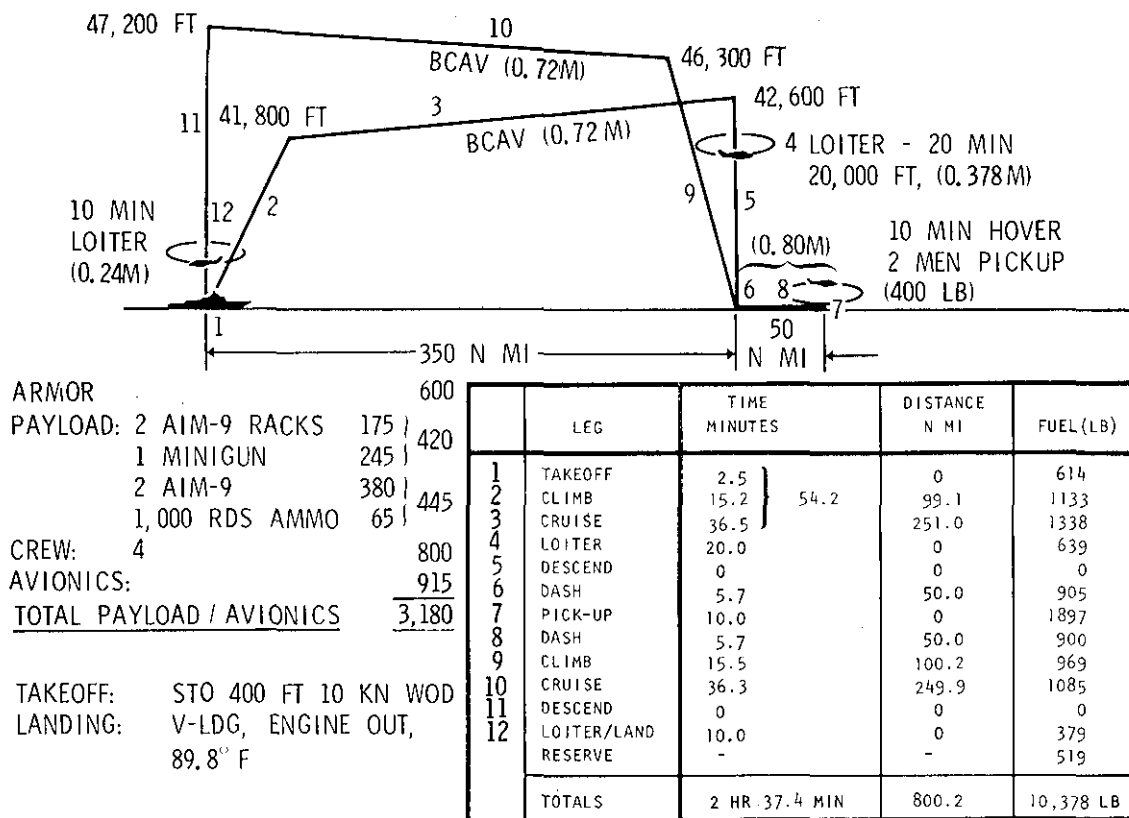
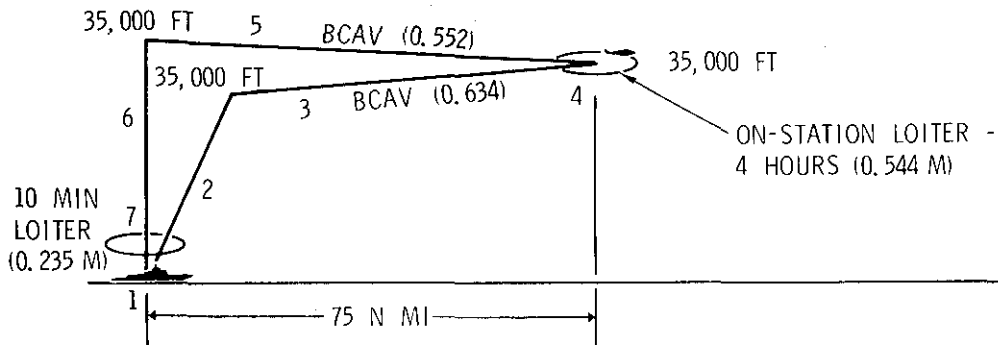

Figure 9. Basic CSAR Mission Performance

aircraft to accompany F-4, A-7 and F-14 strike teams on combat missions without early takeoffs. The CSAR aircraft wing is designed to allow flight up to dynamic pressures of 1000 lb/ft<sup>2</sup> which permits speeds up to 0.8M at sea level. The wing is also designed to allow a maneuver load factor of 5g at the design combat weight, takeoff weight less 40 percent of internal fuel.

The basic performance of the Surveillance version of the multi-mission aircraft is presented in figure 10. Using the aspect ratio 9.0 wing, the



PAYLOAD: AVIONICS 3,555 LB  
 CREW 4 800  
TOTAL PAYLOAD / CREW 4,355 LB

TAKEOFF: STO 400 10 KN WOD  
 LANDING: V-LDG, ENGINE OUT,  
 89.8 F

	LEG	TIME MINUTES	DISTANCE N MI	FUEL (LB)
1	TAKEOFF	2.5	0	615
2	CLIMB	7.6	41.7	692
3	CRUISE	5.46	33.3	175
4	LOITER	240.0	0	6496
5	CRUISE	4.18	75.0	348
6	DESCEND	0	0	0
7	LOITER/LAND RESERVE	10.0	0	349
		-	-	456
TOTALS		4 HR 30 MIN	150 N MI	9131 LB

Figure 10. Basic Surveillance Mission Performance

optimum constant loiter altitude is 35,000 feet which is comfortably above the minimum 25,000 feet altitude desired. Because the required radius is only 75 nautical miles, constant altitude cruise out and returns are assumed. The significant difference in outbound and return aircraft weights causes the noted variations in the cruise leg speeds. The 35,000 foot loiter altitude provides very good radar and electronic surveillance capability. Higher altitudes, up to 45,000 feet, are available at reduced loiter times.

The Surface Attack mission version uses the same aspect ratio 6.0 wing as the CSAR airplane. Its basic performance is presented in figure 11. Because of its use of the 1000 lb/ft<sup>2</sup> dynamic pressure and 5g load factor wing, the aircraft also has good sea level attack maneuvering and speed performance capability.

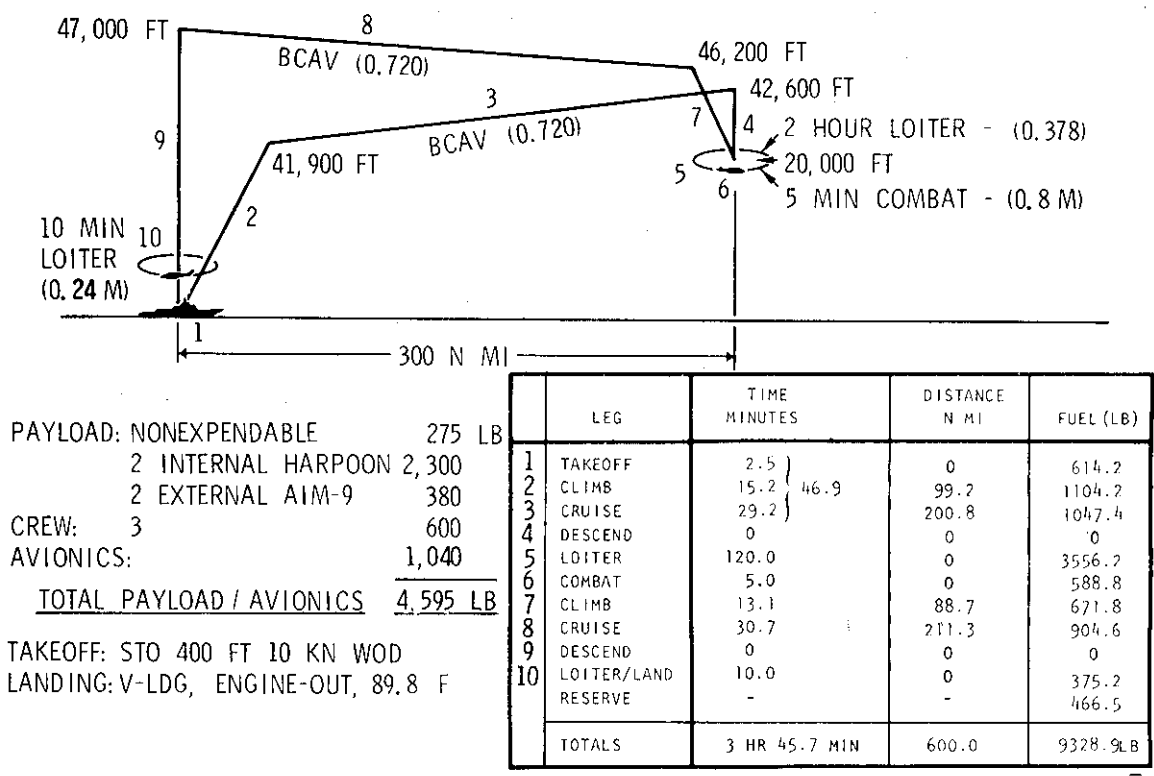

Figure 11. Basic Surface Attack Mission Performance

Figure 12 summarizes the speed-altitude capabilities of the multi-mission aircraft configurations at their respective design combat weights. Except for the CSAR version, the speed altitude capabilities are shown for the case where only the two fans and two gas generators are assumed to be operating. For the CSAR version, the third gas generator is assumed to be operating in the turbojet mode and is contributing to the forward thrust via auxiliary nozzles provided for this purpose. The SA aircraft, with the same wing as the CSAR would have comparable performance to the CSAR with the third gas generator operating in the turbojet mode. The ASW, VOD and Surveillance aircraft that use the 16 degree leading edge sweep, aspect ratio 9.0 wing would also have additional dash capability above that shown, but not quite as good as that indicated for the CSAR airplane because of the differences in wing drag characteristics. The ASW, VOD and Surveillance aircraft are also limited in low altitude high speed capability because their common wing design is limited to 500 lb/ft<sup>2</sup> dynamic pressure. Operationally, these aircraft do not have a high speed requirement at low altitudes and wing and total airplane weight is saved by limiting the speeds. Both the CSAR and SA aircraft wings are designed for 1000 lb/ft<sup>2</sup> dynamic pressure and are capable of speeds to 0.8M at sea level.



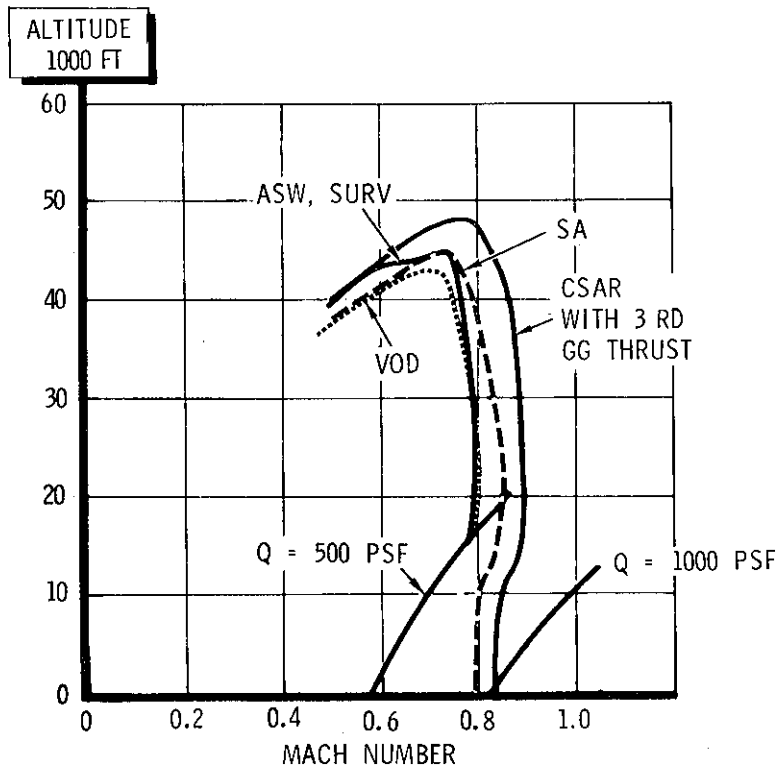

Figure 12. Multi-Mission Aircraft Speed-Altitude Capability

Figure 13 illustrates the takeoff performance of the multi-mission aircraft. The general takeoff requirement for the vehicle is 400 feet

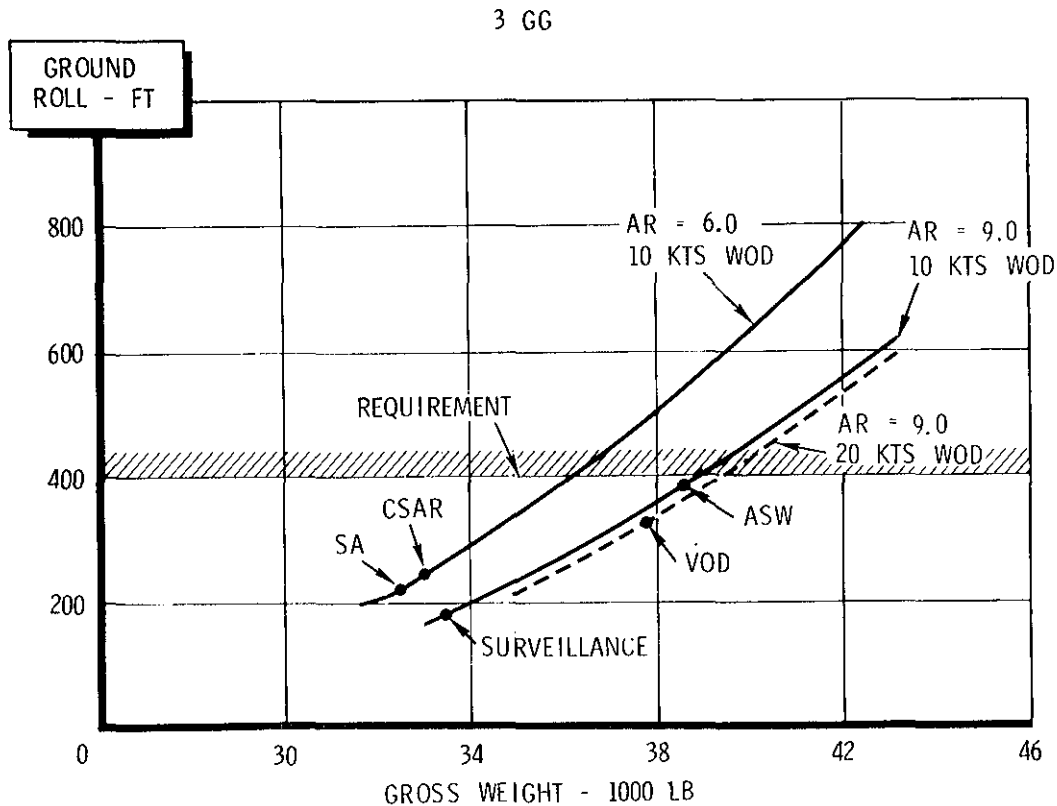

Figure 13. Multi-Mission Aircraft Takeoff Performance

ground roll with 10 knots of wind over the deck at STOL takeoff weight/SL/90°F with 0.065g horizontal acceleration at liftoff with all engines operating. The VOD aircraft however was allowed 450 feet of groundroll with 20 knots of wind over the deck for similar conditions. The ASW at a STOL mission takeoff weight of 38,727 pounds requires the most deck run but is within the distance allowed by the general requirements. The VOD aircraft at its design mission takeoff weight of 37,778 pounds has a groundroll of only about 330 feet; thus it too is within the general requirements. Aircraft weights up to 3000 pounds higher than the design weight could be lifted off within the VOD takeoff guidelines. The CSAR, Surveillance and Surface Attack aircraft greatly exceed the takeoff requirements at their design weights, thus these aircraft could also be operated with overloads of fuel or other expendables within the general takeoff performance constraints.

## Propulsion/Hover Control

The propulsion and hover control systems are designed as an integrated system. Figure 14 shows the basic lift-cruise fan system installation. Two 1.3 design fan pressure ratio single stage VTO design fans are mounted vertically on either side of the fuselage. Two J97-GE-100 gas generators drive the fans through a common interconnect duct system. Integrated single swivel nozzles downstream of the fan exhausts direct the fan flow aft for cruise or downward as required for STOL or VTOL operations. The system uses the Energy Transfer Control (ETC) method of providing hover and low speed control forces.

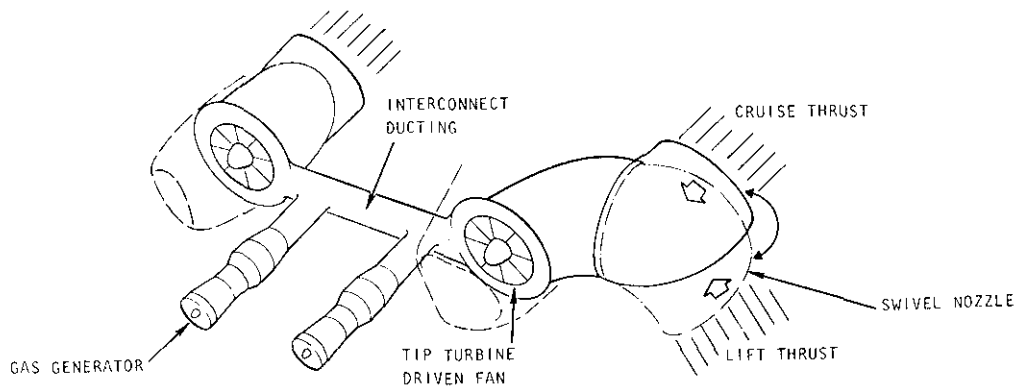

Figure 14. Basic Lift-Cruise Fan System Installation

The system is basically simple and lightweight and provides an interconnect system for VTOL engine out safety and control. An additional benefit of the arrangement is the ability to perform loiters and low speed cruises with one gas generator driving both fans. The ETC thrust modulation provides vehicle hover and low speed roll control and differential operation of the swivel nozzles provides yaw control. Pitch control is provided by a separate system described in the following paragraph.

To provide a proper level of engine out safety and simultaneously provide the vehicle with a fast acting pitch control system, a third gas generator and a fore and aft pitch control pipe system is installed along with the basic lift-cruise fan system of figure 14. Figure 15 illustrates the total propulsion/hover control system as installed in the vehicle. The added gas generator and pitch pipe system normally operate independently of

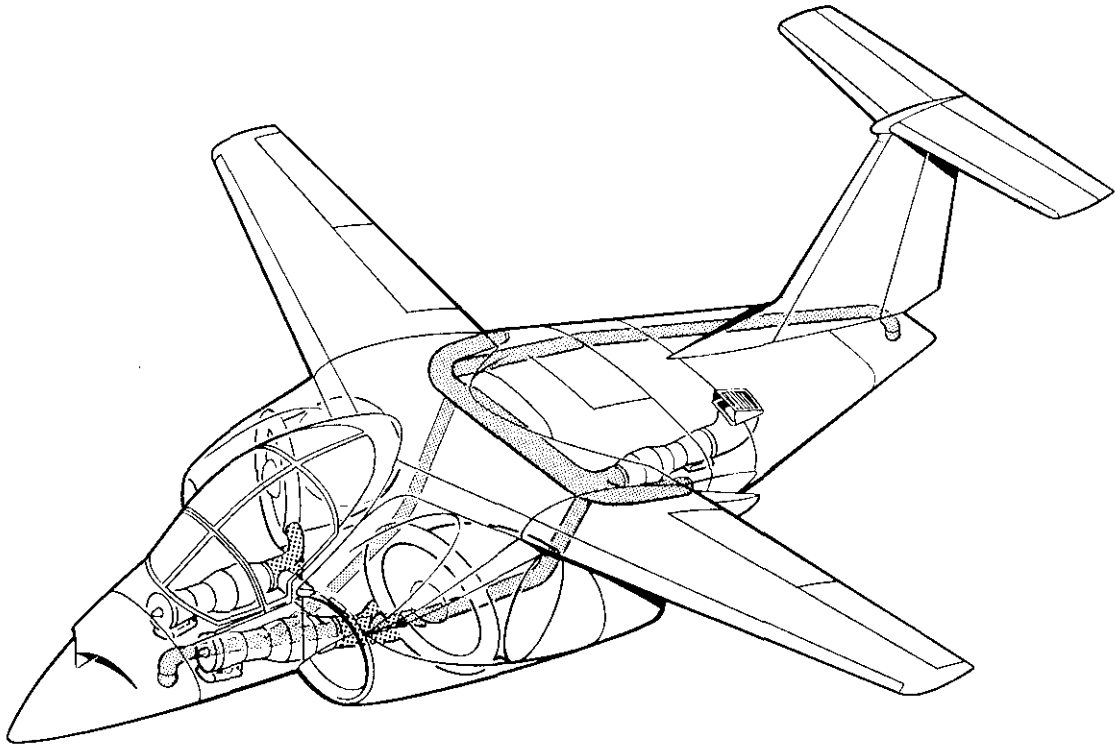

Figure 15. Complete Propulsion/Hover Control System Installation

the lift-cruise fan system and gas generators. The third gas generator system provides nominal V/STOL lift to the system, fast acting pitch control forces with large moment arms and auxiliary horizontal turbojet thrust. Thrust modulation in the third gas generator system is fast because no fan inertia is involved in raising or lowering the thrust. Auxiliary nozzles placed just aft of the wing trailing edge/fuselage juncture allow the third gas generator exhaust to add to the vehicle horizontal thrust capability either in the low speed mode or for high speed dash capability. The lift-cruise fan system and the third gas generator system can be interconnected in the event of a gas generator failure in either system. This interconnection allows the gas from the remaining two gas generators, operating at their emergency ratings with water injection, to be distributed to both systems in a manner that will bring about the most desirable results after the failure.

Table 2 illustrates the installed thrust available from each element of the lift-cruise fan system for various thrust ratings on the gas generator when one gas generator is driving one fan.

Table 2

## LIFT-CRUISE FAN SYSTEM VTO THRUST RATINGS

S. L. S 90°F DAY  
 SWIVEL NOZZLE DEFLECTION = 0°

POWER SETTING	THRUST, LB	THRUST
		THRUST <sub>1 MIN VTO</sub>
INTERMEDIATE	12946	0.959
1 MIN VTO	13500	1.0
3 SEC VTO	15660	1.16
EMERGENCY	14135	1.047
EMERGENCY WITH H <sub>2</sub> O	15831	1.173
3 SEC VTO WITH H <sub>2</sub> O	17106	1.267

In addition to the lift-cruise fan system thrusts, the third gas generator system can produce installed SL/90°F static thrusts up to 4757 pounds at intermediate power, 4900 pounds at 1 minute VTO rating and 5748 pounds at emergency power with water injection.

The propulsion/hover control system operation is most critical in the VTOL modes. Figure 16 illustrates the capabilities of the system relative to the critical requirements. The shaded portions of the bars and unshaded extensions indicate the system capabilities for various system assumptions and the associated arrows indicate the level of the various requirements in terms of total vehicle lift. The left bar indicates the considerations for initiation of the mid-mission hover on the CSAR mission. At this condition the system can provide a T/W of 1.03 on intermediate power. To provide the full control capability desired for this condition, the hover can be initiated alternately with the 1-minute gas generator rating or water injection, on demand, for control only. Hover without full control requirements can be handled, on intermediate power only.

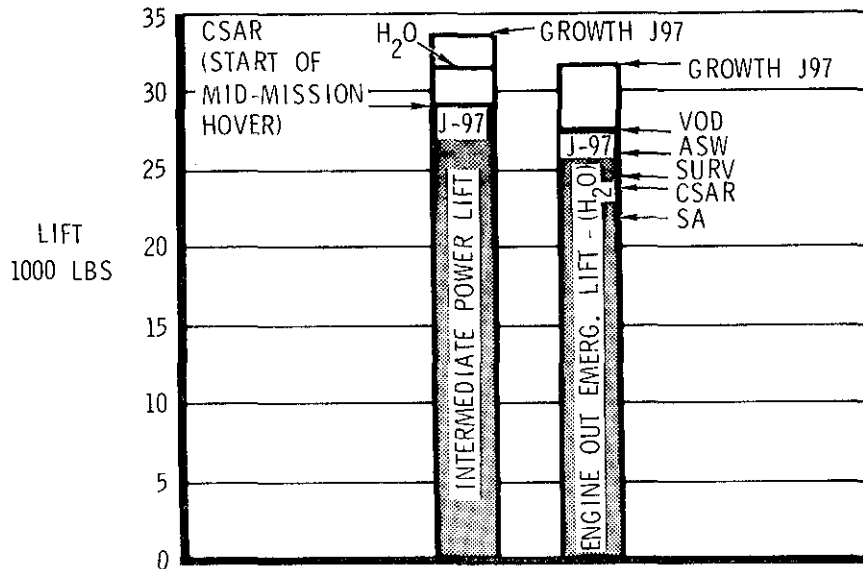

Figure 16. Hover and VTOL Operation Lift Capabilities

The right bar of figure 16 indicates the design considerations for the emergency landing situation where the requirements indicate that a  $T/W = 1.0$  is desired after an engine failure when the vehicle has 1000 pounds of fuel onboard and has dropped its expendable payload. The VOD aircraft, because of its large non-expendable payload, is the most critical case. Using emergency ratings with water injection on the remaining gas generators provides enough lift to provide  $T/W = 1.0$  plus the emergency attitude control power requirements for the VOD and all the other cases as shown by the right bar and arrows.

A representative hover control analysis plot is shown in figure 17. Figure 17 presents the hover control power available to the VOD version of the multi-mission aircraft during the emergency landing case.

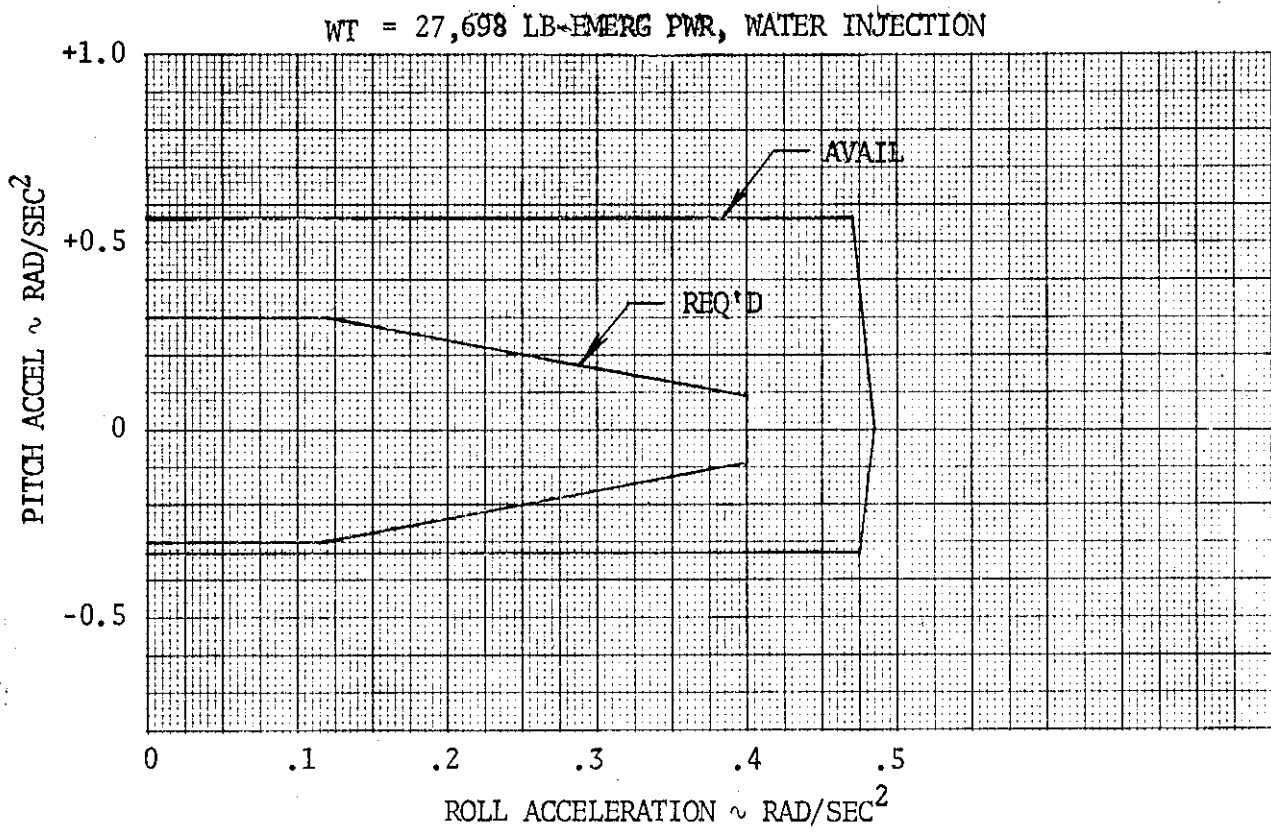

Figure 17. Hover Control Power -VOD Emergency Landing

Should mission definitions change or weight growth be experienced in the detailed design phase of airplane development, a growth version of the J97 gas generator could be employed to assure adequate operational characteristics as shown by the bar extensions on figure 16 indicating the lift levels to be available with a growth J97.

## AERODYNAMICS & LOW SPEED CHARACTERISTICS

The aerodynamic configuration of the multi-mission aircraft was designed to complement the characteristics of the J97 size 1.3 FPR single-stage lift-cruise fan propulsion system to produce efficient total system designs for the five operational missions. A relatively high aspect ratio 9.0 wing outer panel with winglets was selected to provide good loiter performance, adequate takeoff ground roll characteristics and long-range cruise efficiency for the ASW, Surveillance and VOD missions. A lower aspect ratio 6.0 outer wing panel with winglets was selected for the CSAR and SA aircraft configurations to provide better low altitude high-speed capability and a lighter wing for the maneuvering load factors required.

Representative examples of the aerodynamic efficiency of the configurations are presented in figures 18 and 19. Figure 18 presents the trimmed cruise L/D for the aircraft using each design wing panel as a function of the operating lift coefficient. The  $C_L$  for L/D max is heavily influenced by the fuselage afterbody drag characteristics and the wing/fuselage incidence angle. The data are shown for an arbitrary incidence angle of zero degrees.

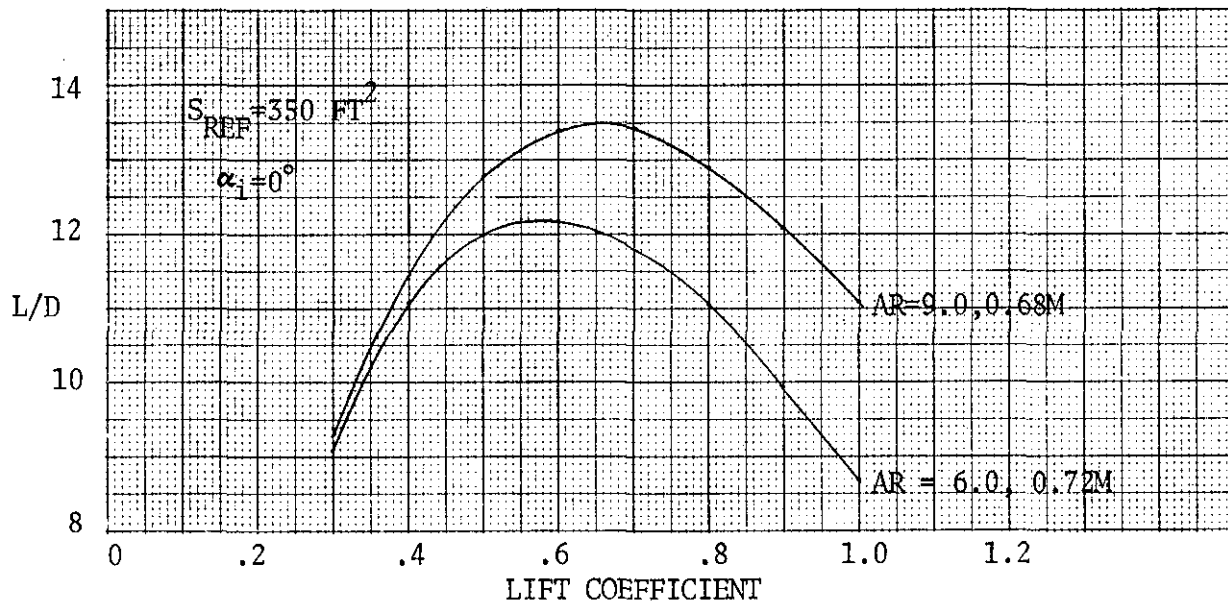

Figure 18. Trimmed L/D vs. Lift Coefficient

Figure 19 presents the low speed flaps down polars for both wings. The  $C_L$  max for the AR = 9.0 wing is 3.12 and 1.90 for the AR = 6.0 wing. At the operational limit of 0.8  $C_L$  max the AR = 9.0 wing has an L/D of 5.6 and the AR = 6.0 wing has an L/D of 5.0 .

The current location of the integrated single swivel nozzle under the wing near the vehicle CG produces a slight loss in aerodynamic lift at forward



speed when the nozzle flow is directed down as shown in figure 20. This small loss does not cause any compromise in the mission performance objectives because of the high lift efficiency of the basic wing. Refinement of the design in the direction of improved STOL performance is possible if STOL performance greater than the guideline requirements is later found to be desirable.

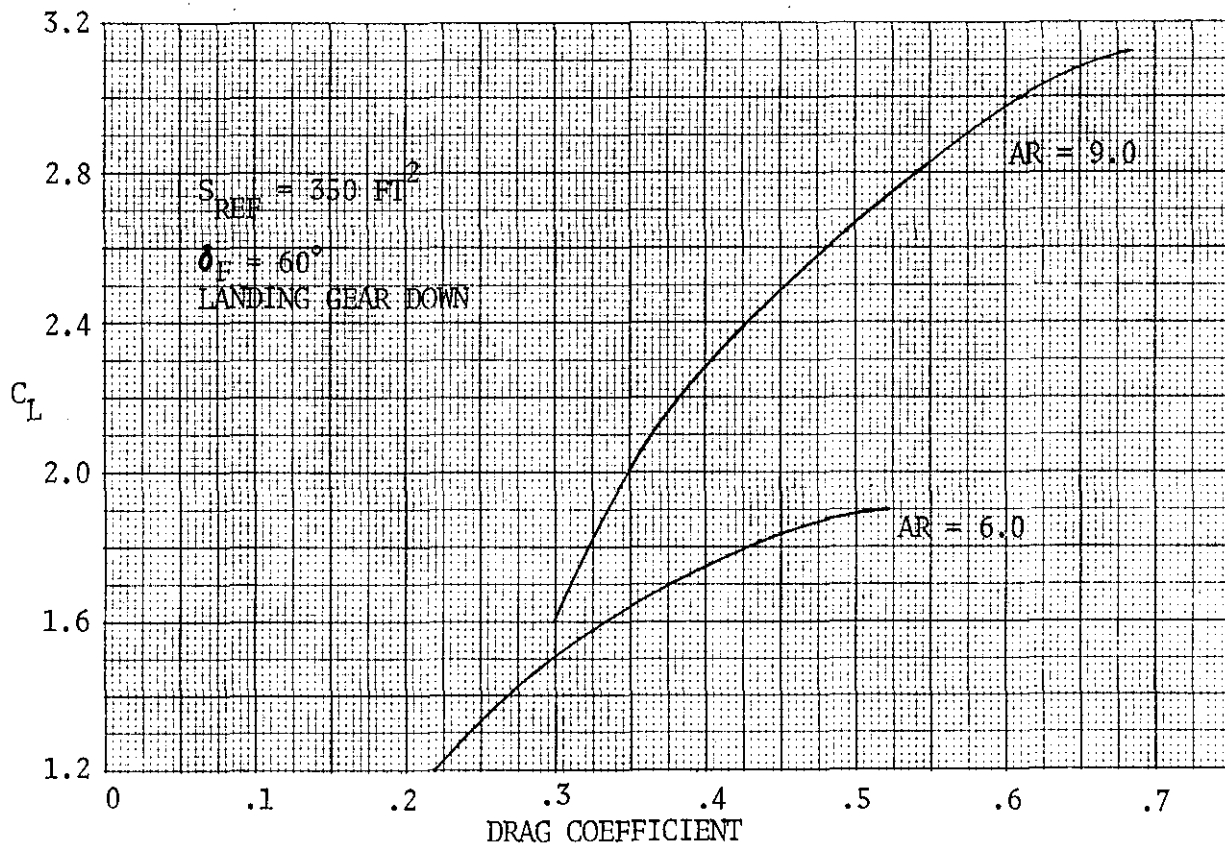

Figure 19. Low Speed Power Off Drag Polars

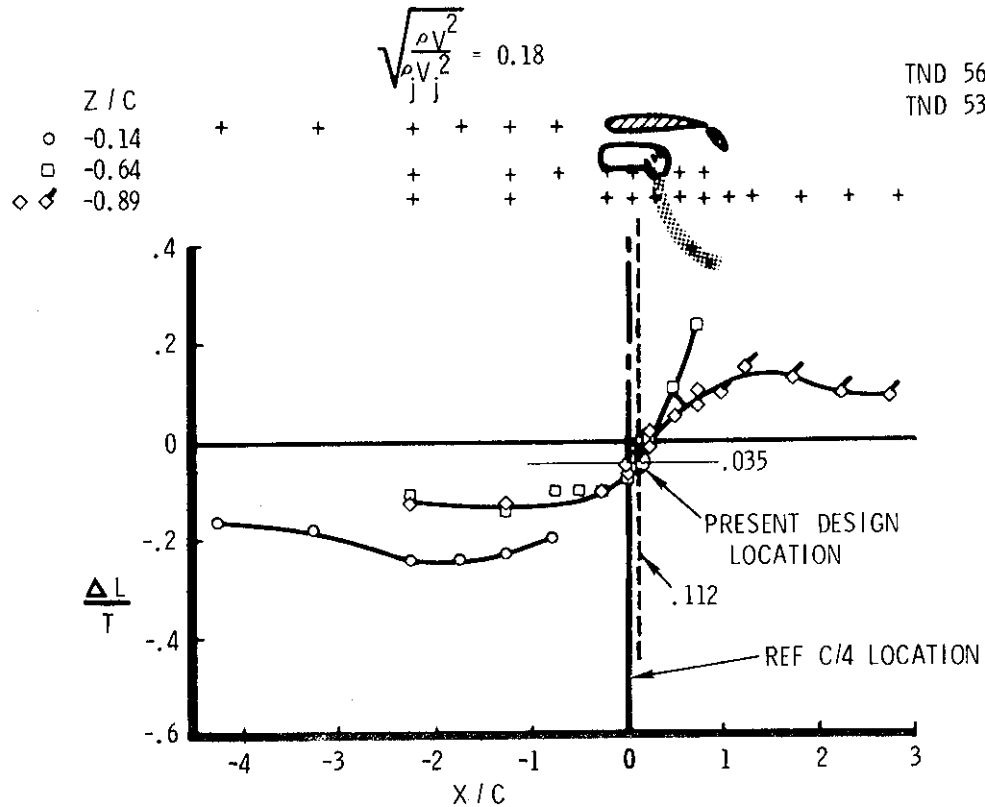

Figure 20. Low Speed Propulsion/Aerodynamic Interaction Characteristics

Figures 21 through 26 present representative control characteristics of the aircraft in the low forward speed regime. The data show the capability to achieve control attitude angle changes in one second compared to the guidelines. The capability to achieve roll angles during descent are presented because roll control power is more critical in the descent mode. The normal pitch attitude angle performance of figure 23 assumes 100 percent of the thrust of the third gas generator is available, while the one gas generator out emergency data of figure 24 assumes only 38 percent is available, the remainder is employed in direct production of lift. Water injection is used below 52 KEAS to provide the level of pitch control shown. The yaw data of figures 25 and 26 show the vehicle control performance relative to the guidelines without crosswind. The lower requirements with crosswind are also easily met. The low speed control analyses generally indicate that the vehicles are expected to have satisfactory low-speed control capability.

Cruise mode stability and control checks have shown that the vehicle satisfactorily meets the 5 percent static stability margin at all operational configurations and weight/CG loadings.

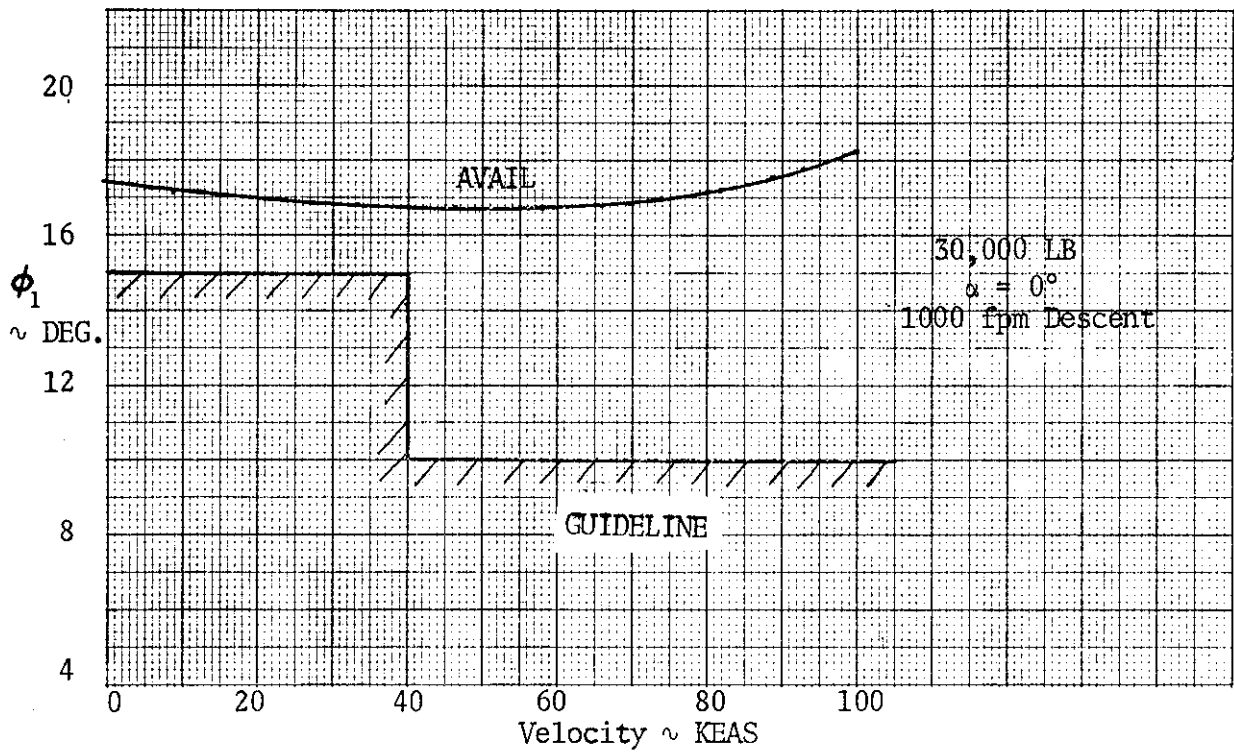

Figure 21. Normal Roll Attitude Angle Attained in One Second

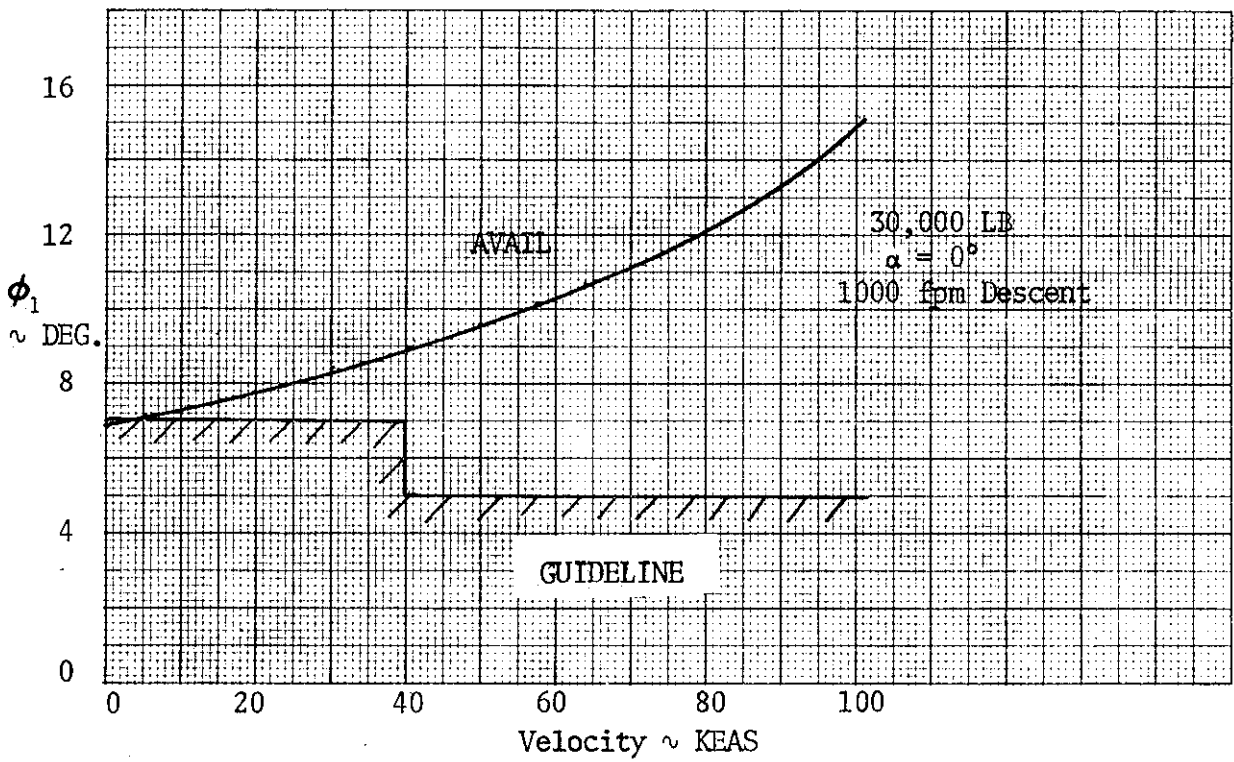

Figure 22. Emergency Roll Attitude Angle Attained in One Second

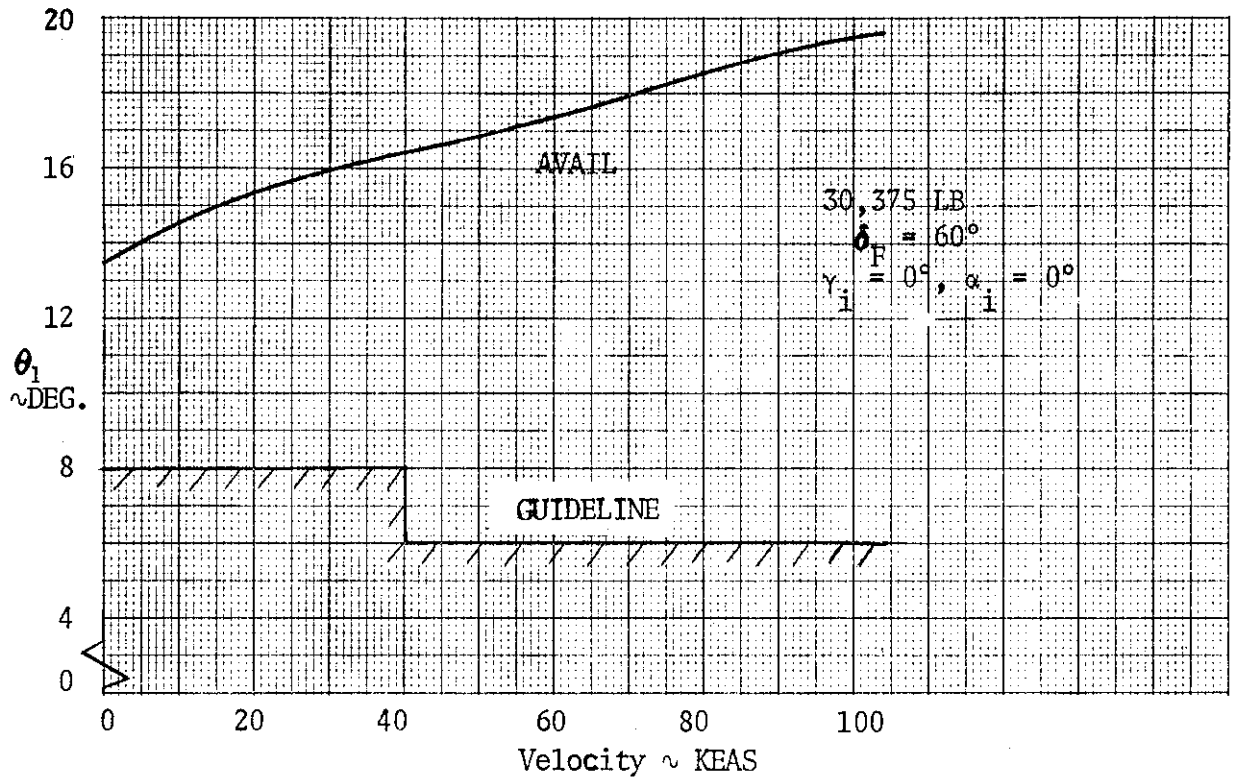

Figure 23. Normal Pitch Attitude Angle Attained in One Second

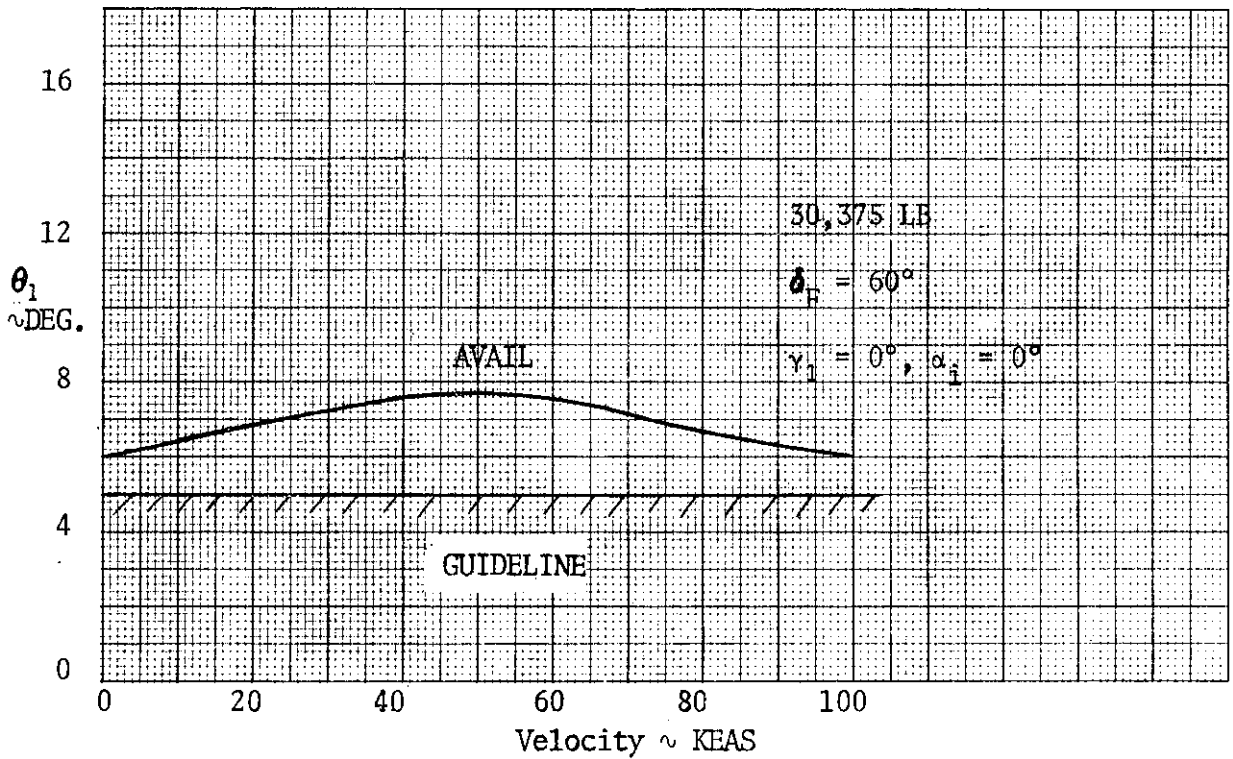

Figure 24. Emergency Pitch Attitude Angle Attained in One Second

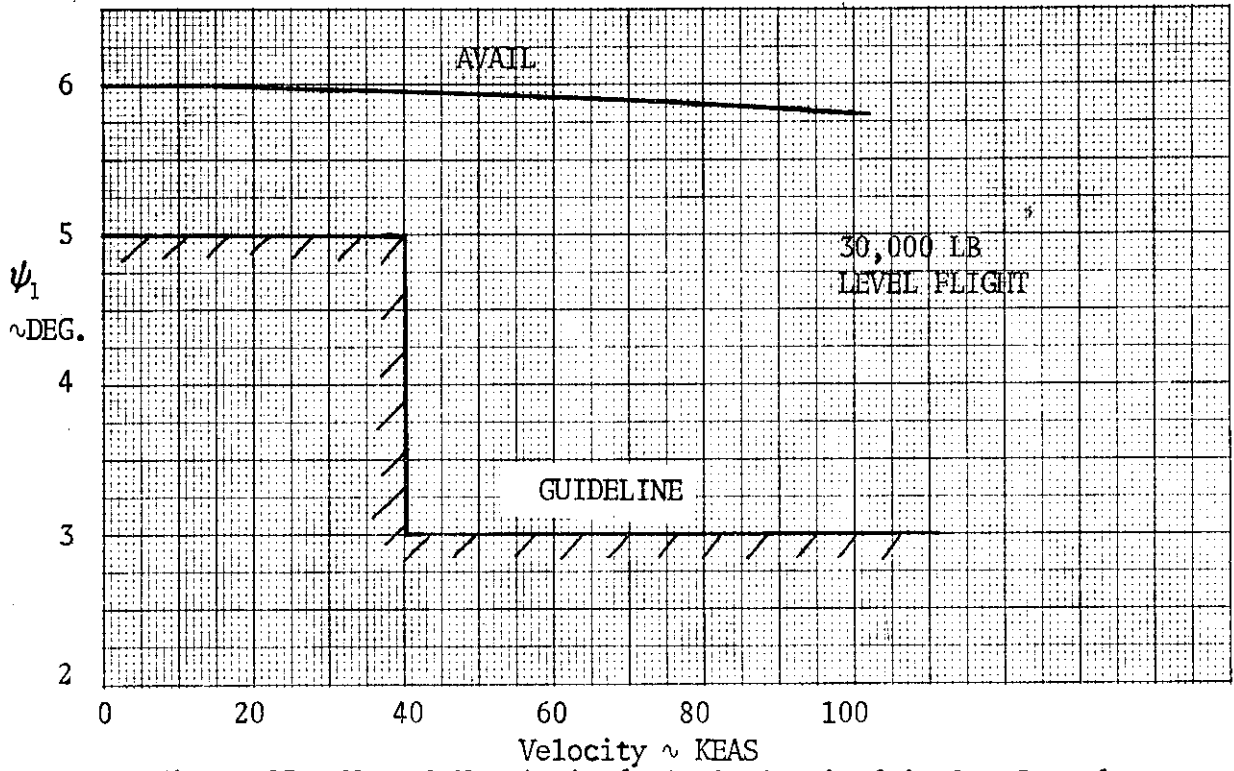

Figure 25. Normal Yaw Attitude Angle Attained in One Second.

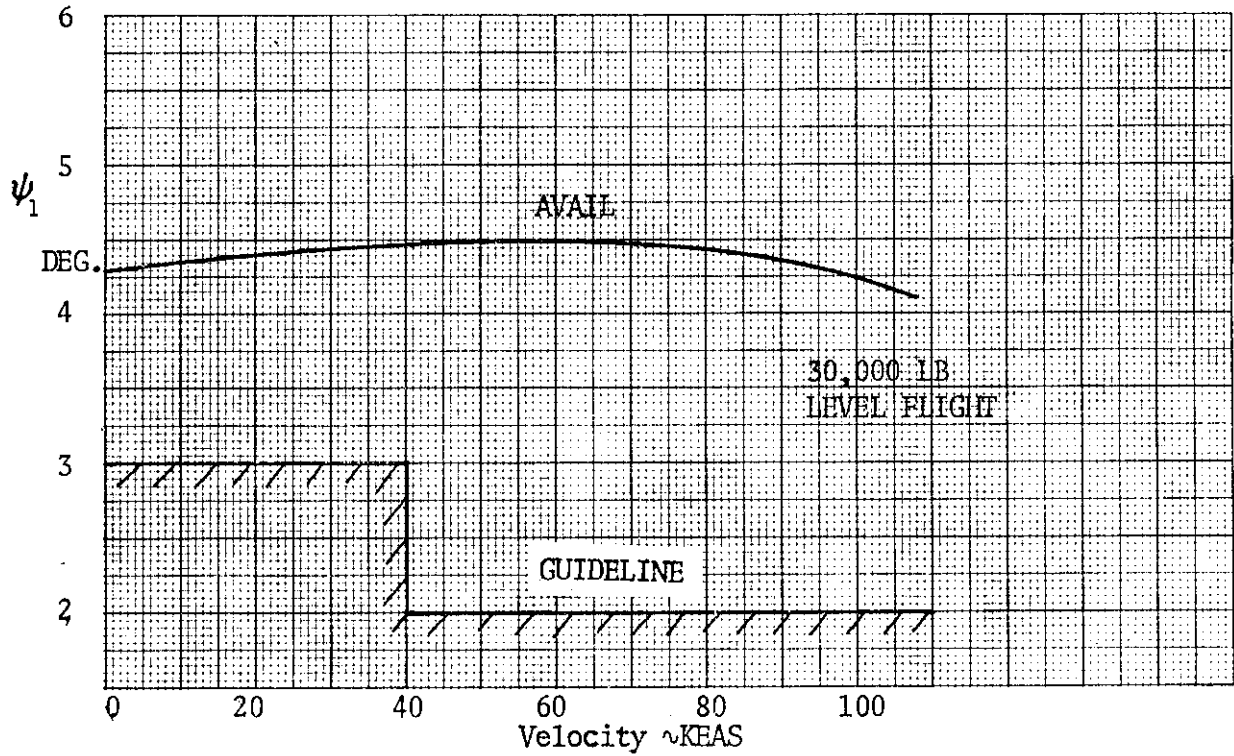

Figure 26. Emergency Yaw Attitude Angle Attained in One Second

## Structure

The structural design of the multi-mission aircraft is based on the use of advanced composite material technology. Preliminary evaluations of the composite technology trends, including review of current available test results and interim results of on-going development programs, indicated that weight savings approaching 24 percent might possibly be achievable by the early 1980's. Selected structural analysis of specific multi-mission aircraft structure indicated that the probable weight saving, however, would be of the order of 18 percent. Of the likely 18%, 15 percent of the primary structure was judged to be within the cost-effective guidelines established for the study. The 15% weight reduction relative to a metal airplane was applied to the wing, empennage and body groups. A 10% estimated weight saving for the landing gear was assumed and 10% for the engine section structural weight saving. No weight reduction for use of composites was assumed for the air induction system. The weights resulting from the use of these reductions are presented in the mass properties section of the report.

The design structural strength of multi-mission V/STOL configuration is based on the design requirements of MIL-A-8860 series specifications. The limit maneuver load factors are +3 and -1 for the ASW, VOD and Surveillance aircraft which use the aspect ratio 9.0 outer wing panels and +5 and -1 for the CSAR and SA which use the aspect ratio 6.0 outer panels. The limit speed for the aircraft is based on a maximum dynamic pressure limit or a maximum mach number of 0.885 whichever is the lowest. For the CSAR/SA aircraft the design maximum dynamic pressure is 1000 PSF while the other aircraft are limited to 500 PSF. The landing sink speeds are 15 FPS at the structural design landing weight and 13 FPS at maximum design gross weight. The maximum design weight has a 10 percent growth factor applied to the sum of the normal STOL mission takeoff weight plus the weight of 2600 pounds for two store stations.

The structural landing weight is the maximum vertical takeoff weight. The basic flight design weight is normal mission takeoff weight less 40 percent of internal fuel. The weights per these definitions are as follows:

	<u>ASW</u>	<u>VOD</u>	<u>SURV.</u>	<u>CSAR</u>	<u>S.A.</u>
Normal Takeoff	38728	37778	33161	32988	32359
Basic Flight Design	34294	33220	29509	28837	28627
Maximum Design	45461	44416	39337	39147	28455
Landing Design	29000	29000	29000	29000	29000

The cabin pressure schedule is 8000 feet to 50,000 feet which is a pressure differential of 9.25 PSI limit to which the normal factors of safety of 1.33 and 1.5 are applied per MIL-A-8861A. The fuselage primary structural shell is critical for the CSAR maneuver loads, internal pressure and the panel

stiffness requirements for 1000 PSF. The wing center section is critical for the CSAR maneuver requirements. The aspect ratio 9.0 outer panels are gust critical for those aircraft with a maneuver load factor of 3. The CSAR and SA outer panel is maneuver critical. The empennage is gust and stiffness critical based on the CSAR design envelope.

### Subsystems

The air vehicle subsystems for the 1980-1985 lift-cruise fan airplanes include advanced state-of-the-art concepts that could be expected to be ready for engineering development with the aircraft in the stated time period. Only items that were experiencing steady development and funding toward the identified goals were considered. Brief summaries of the subsystem concepts and design features are presented below.

The vehicle flight control concept is based on a quadruple redundant fly by wire system. The subelements of the system are the primary flight control system, a propulsion attitude control system, an electrical thrust control system and a thrust vector control system. Both the primary and the propulsion attitude control systems include command stability augmentation subsystems. The primary flight controls include a trimmable all moving horizontal tail with a segmented elevator, a segmented rudder, dual segment direct lift and drag control spoilers on the inboard portion of each wing, triple segment roll control spoilers on the outboard wing, leading edge flaps, and double-slotted fowler trailing edge flaps. The propulsion attitude control system provides pitch, roll and yaw control of the vehicle during low speed operations by controlling the pitch nozzles, propulsion system butterfly control valves, the vectoring of the integrated single swivel nozzles and the thrust spoiling devices integrated into the fan exhaust nozzles. The electrical thrust control system modulates thrust by controlling the gas generators. The thrust vector control system provides synchronized thrust vectoring by controlling the rate of rotation of the swivelling nozzles and modulating the thrust distribution through the pitch and auxiliary nozzle to synchronize the total vehicle thrust vector for STOL and VTOL transition maneuvers. Fly by wire elements and individual components of the flight control system are experiencing considerable development, thus only system integration, sizing and engineering development of specific hardware is expected to be required. The integration of the system with the cockpit controls and displays will likely require some ground based flight simulator development.

The auxiliary power unit (APU) systems on the multi-mission aircraft will use the evolutionary improved hardware expected to be available in the specified time period. For the ASW and Surveillance mission aircraft, which have large avionic equipment loads, the APU's will be designed for continuous operation during the mission to supply air for the equipment environmental control systems. The installations will provide high inlet efficiencies to allow operation at high altitudes.

The hydraulic system will consist of two primary 6000 psi systems, each driven by 15 GPM pumps. A 5 GPM emergency/checkout APU driven system is also provided. The lines will be titanium with brazed/swaged joints.

The electrical system will consist of dual primary variable speed constant frequency (VSCF) high voltage AC systems. Two 60 KVA fan mounted generators will be used on the ASW and Surveillance aircraft and 30 KVA generators will be used on the VOD, CSAR and SA aircraft. Primary DC power will be provided through transformer rectifiers. Emergency and ground checkout DC power will be provided by Ni-Cad battery. AC emergency power will be provided by a 5 KVA emergency APU driven generator.

The multi-mission aircraft avionics equipment will be tailored to the requirements of the individual missions. The avionics for the ASW and Surveillance missions were specified by the study guidelines. The avionics for the other missions consist of the standard communications, navigation and flight instrument requirements plus the specialized equipment necessary to operate the mission payloads as defined in the study guidelines. The weights of the avionics systems, including installation provisions are:

ASW	3100 lb
SURV	3555 lb
SA	1040 lb
CSAR	915 lb
VOD	565 lb

The environmental control system used on the aircraft will feature evolutionary improvements of current air cycle systems using ram air heat sinks and dual turbo-compressor refrigeration units. Bleed air will be provided by a large continuously operated APU for the ASW and Surveillance missions with backup air provided by the gas generators. Because of the lower requirements of the other mission aircraft, the primary source will be the gas generators with backup provided by a smaller onboard APU which will be run only on demand. Pressurization and sealing will be provided by the bleed air sources. Windshield anti-icing will be electrical and engine inlet anti-icing will be by bleed air. The ASW and CSAR aircraft will have additional flight surface leading edge protection by inflatable rubber boots because of their expected long flight operations at lower altitudes where icing conditions prevail.

The furnishings and armament subsystems provided each aircraft are tailored to each individual mission. The equipment provided is consistent with the functions and specific equipments and armament specified in the study guidelines.



## Mass Properties

The estimated weights for the alternate mission versions of the multi-mission airplane are based on the advanced composite structural technology and advanced subsystem and equipments described in previous sections of the report. A listing of the STOL takeoff weight fractions of the major weight summary groups is presented in Table 3 below. The complete group weight summaries by mission are presented in Table 4. The center of gravity

Table 3. SUMMARY OF MAJOR GROUP WEIGHT FRACTIONS BY MISSION

	<u>ASW</u>	<u>VOD</u>	<u>SURV</u>	<u>CSAR</u>	<u>SA</u>
STRUCTURE	0.247	0.257	.282	.279	.279
PROPULSION	0.163	0.170	.188	.194	.194
EQUIPMENT	0.179	0.115	.209	.153	.120
USEFUL LOAD	0.125	0.157	.046	.059	.119
MISSION FUEL	<u>0.286</u>	<u>0.301</u>	<u>.275</u>	<u>.315</u>	<u>.288</u>
STOGW	38,728	37,778	33,161	32,988	32,359

travel and inertias for each mission configuration are presented in figure 27. The major fuselage and tail structure, propulsion, hydraulics and flight control installations are identical for all mission configurations. Only two alternate electrical and APU systems are required to meet all mission requirements. The remainder of the mission peculiar equipment, fuel and other useful load items are installed in the basic airframe shell to maximize beneficial center of gravity travel characteristics for each mission configuration.

TABLE 4. GROUP WEIGHT SUMMARIES BY MISSION CONFIGURATION

	A.S.W.	SURV.	S.A.	C.S.A.R.	V.O.D.
<b>STRUCTURE GROUPS</b>	(9557)	(9336)	(9024)	(9209)	(9696)
WING GROUP	3030	3030	2588	2588	3030
TAIL GROUP - HORIZONTAL	328	328	328	328	328
- VERTICAL	458	458	458	458	458
BODY GROUP	4295	4074	4204	4389	4434
ALIGHTING GEAR GROUP - MAIN	804	804	804	804	804
- AUXILIARY	225	225	225	225	225
ENGINE SECTION OR NACELLE GROUP	272	272	272	272	272
AIR INDUCTION SYSTEM	145	145	145	145	145
<b>PROPULSION GROUP</b>	(6327)	(6231)	(6281)	(6400)	(6419)
ENGINE (AS INSTALLED)	2265	2265	2265	2265	2265
ACCESSORY GEAR BOXES & DRIVES	200	200	200	200	200
EXHAUST SYSTEM	940	940	940	940	940
COOLING & DRAIN PROVISIONS	30	30	30	30	30
ENGINE CONTROLS	90	90	90	90	90
STARTING SYSTEM	95	95	95	95	95
FUEL SYSTEM	277	181	231	350	369
FAN (AS INSTALLED)	1710	1710	1710	1710	1710
HOT GAS DUCT SYSTEM	660	660	660	660	660
H <sub>2</sub> O INJECTION SYSTEM	60	60	60	60	60
<b>EQUIPMENT GROUPS</b>	(6943)	(6928)	(3899)	(5049)	(4338)
FLIGHT CONTROLS GROUP	604	604	545	545	604
AUXILIARY POWER PLANT GROUP	335	335	200	200	200
INSTRUMENTS GROUP					
HYDRAULIC & PNEUMATIC GROUP	354	354	354	354	354
ELECTRICAL GROUP	655	655	505	505	505
AVIONICS GROUP	3100	3555	1040	915	565
ARMAMENT GROUP	130	--	60	95	--
FURNISHING AND EQUIPMENT GROUP	1245	1025	1000	1540	1790
AIR CONDITIONING GROUP	370	370	165	145	290
ANTI-ICING GROUP	130	10	10	130	10
PHOTOGRAPHIC GROUP					
LOAD & HANDLING GROUP	20	20	20	20	20
ARMOR	--	--	--	600	--
<b>TOTAL WEIGHT EMPTY</b>	22827	22495	19024	20658	20453
CREW	800	800	600	800	600
FUEL - UNUSABLE	110	110	81	97	141
FUEL - USABLE	11086	9131	9329	10378	11394
OIL - ENGINE	30	30	30	30	30
PASSENGERS / CARGO					5000
ARMAMENT - NON EXPENDABLE	465	--	275	420	--
- EXPENDABLE	2775	--	2680	445	--
APU FUEL	575	535	100	100	100
H <sub>2</sub> O	60	60	60	60	60
<b>TOTAL USEFUL LOAD</b>	15901	10666	13155	12330	17325
<b>TAKEOFF GROSS WEIGHT</b>	38728	33161	32359	32988	37778
<b>FLIGHT DESIGN GROSS WEIGHT</b>	34294	29509	28627	28837	33220
<b>LANDING DESIGN GROSS WEIGHT</b>					

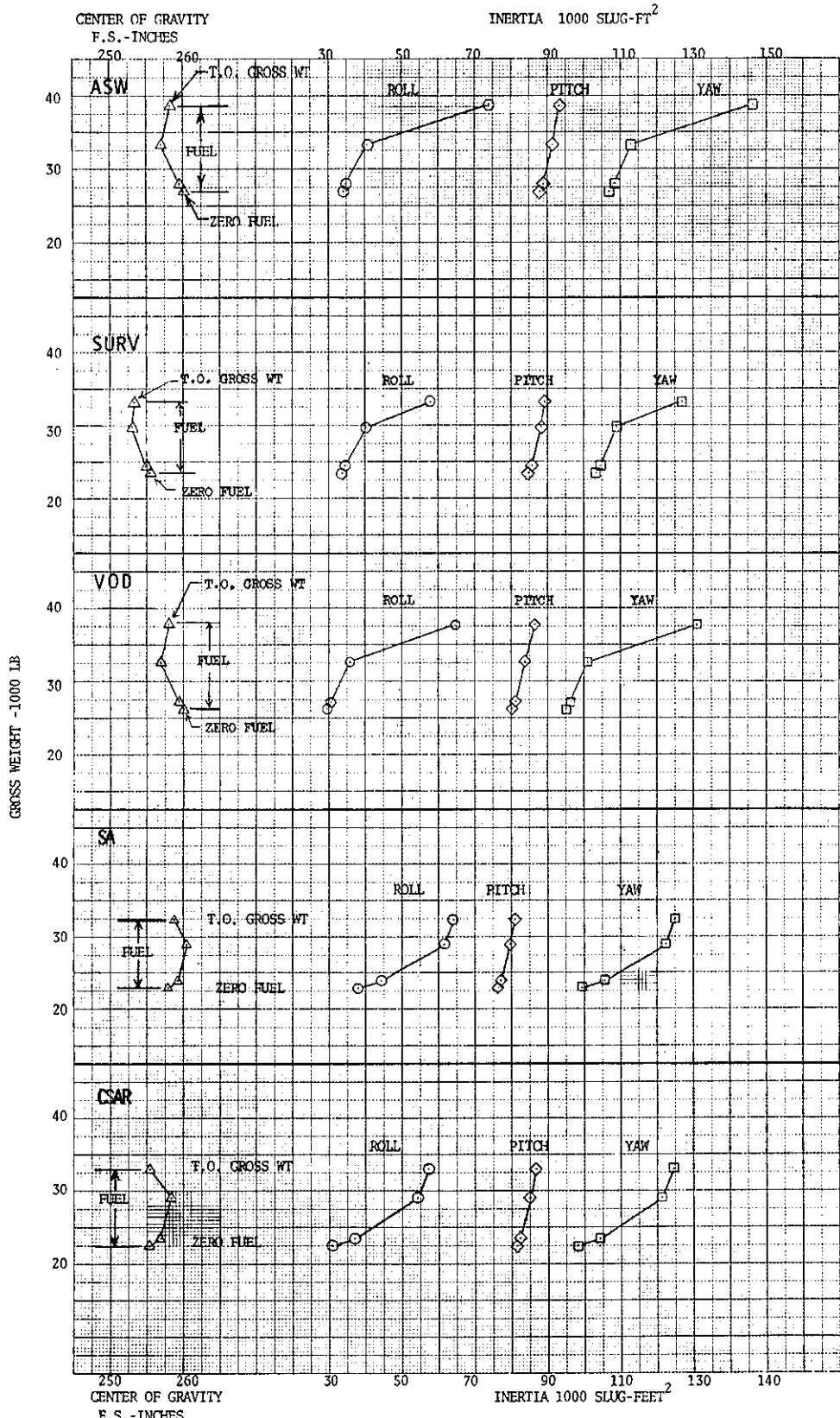

\*Inertias are presented for stores on configuration

Figure 27. Center of Gravity Travel and Inertia Characteristics by Mission

## OPTIMIZED PRELIMINARY CONCEPTUAL AIRCRAFT

Based on initial trade studies, a two fan/three gas generator lift-cruise fan propulsion system was identified as the most desirable. During the development of the optimized aircraft for each of the design missions, the selection of fan was not constrained by guideline other than that a technology developable by 1985 be used. A common result of these optimization studies was that a two-stage VTO design fan emerged as the preferred type. The lighter weight and reduced size of the two stage fans led to their selection for the optimized aircraft. The desired fan pressure ratio was a function of the mission but the smaller diameter of the two-stage fan consistently allowed a lighter overall gross weight aircraft relative to aircraft using single stage fans.

During development of the compromise multi-mission aircraft configuration, the applicable study guideline was to minimize technical risk in the propulsion system development. Because the two stage fan was expected to take more development effort and entailed more risk, a single stage fan was selected for the compromise multi-mission aircraft. Both the optimized and the multi-mission aircraft used three of the currently available J97-GE-100 gas generators.

The selected aircraft configuration based on trade studies consisted of a high mounted wing using a supercritical airfoil and a T-tail. This basic concept was then optimized for each individual mission by tailoring the lift-cruise fan design fan pressure ratio, the wing aspect ratio, wing loading and other aircraft features to the specific mission requirements. The required STOL takeoff weights of the optimized aircraft were from approximately 3000 to 5000 pounds less than the corresponding multi-mission configurations. These reductions were due to elimination of the VOD cargo bay and the CSAR structural design criteria from the missions not requiring them and due to selection of optimum wing designs and use of high pressure ratio two-stage fans. The following paragraphs summarize the characteristics identified for the optimum aircraft for each mission.

### Anti-Submarine Warfare (ASW) Aircraft

Figure 28 presents a design brief of the selected optimum ASW aircraft. Because of the four hour loiter requirement which is responsible for 63 percent of the required fuel, the design is optimized primarily to minimize the fuel required for low speed loiter at 10,000 feet. This results in selection of a relatively low fan design pressure ratio and a high aspect ratio, 18 percent thick wing with a winglet. Cruise speed is 367 knots. The loiter is performed with one gas generator driving both fans to minimize fuel consumption. Takeoff gross weight to do the mission is 35,765 pounds.

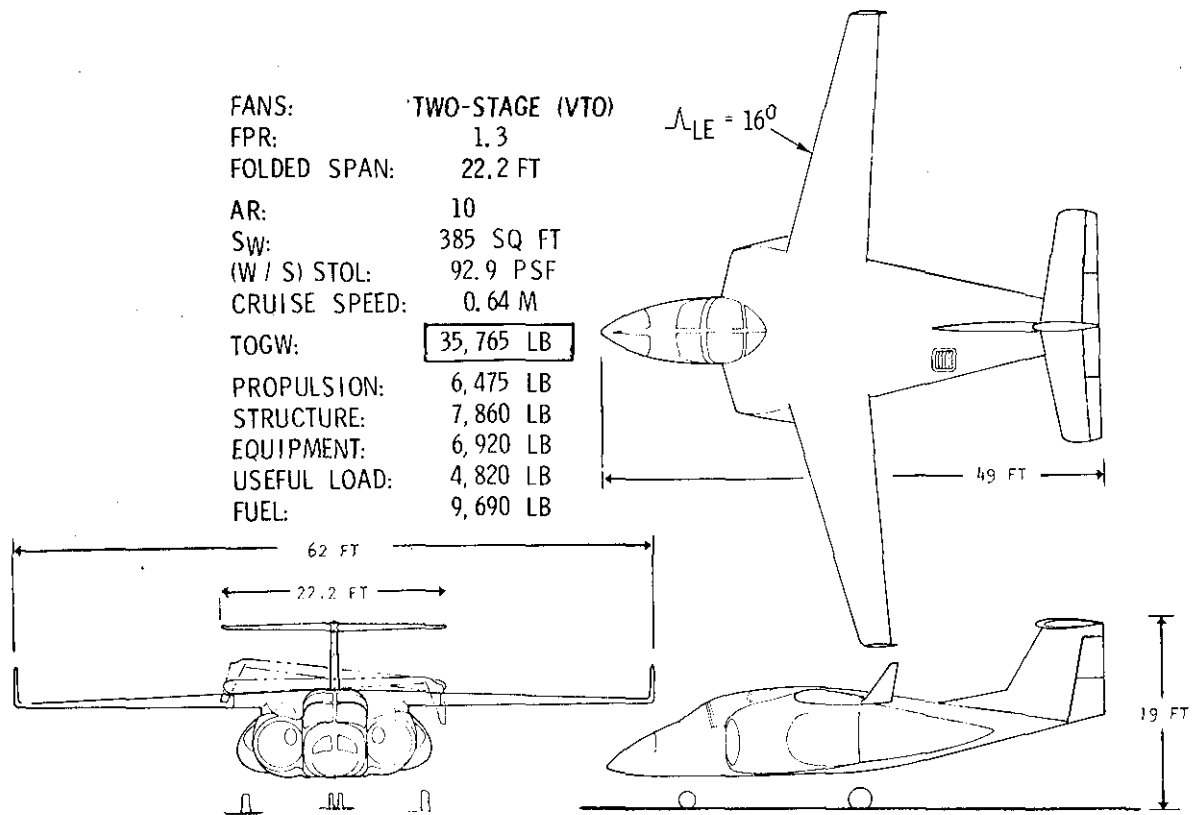

Figure 28. Optimized ASW Aircraft Design Brief

### Vertical Onboard Delivery (VOD) Aircraft

The design brief of the optimized VOD aircraft configuration is shown in figure 29. The VOD mission features a relatively long range high speed requirement where 75 percent of the fuel is used in the cruise leg. To optimize the configuration for this flight requirement, a high design fan pressure ratio is selected and a wing with reduced aspect ratio (7.5) and thickness (15%) with winglets is selected. The high design FPR was selected because of its higher thrust-to-weight ratio at the cruise condition and its smaller size which reduces the nacelle size, weight and drag. Likewise, the wing geometry selection was based on the need to reduce wetted area and pressure drag characteristics for more efficient high speed flight. Cruise speed is just under 420 knots which is sufficient

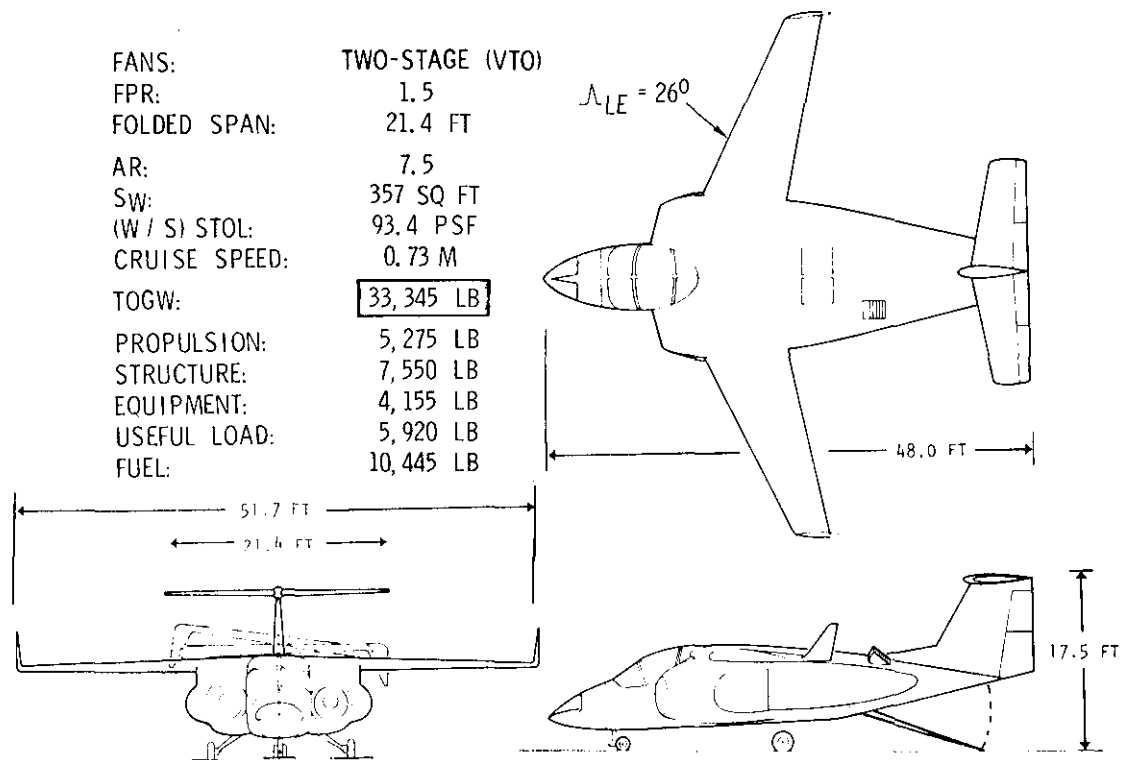

Figure 29. Optimized VOD Aircraft Design Brief

to complete the 2000 nautical mile trip in five hours and 11 minutes including the 20 minute end of mission loiter. The required STOL takeoff weight to do the mission is 33,345 pounds.

#### Combat Search and Rescue (CSAR) Aircraft

The optimized CSAR configuration design brief is presented in figure 30. The CSAR mission has an 0.8 mach number dash requirement at sea level which normally would drive the fan pressure ratio selection to a high value, but, the mid-mission hover requirement dictates a need for high static thrust which is better met with low design fan pressure ratio. The compromise between these two requirements led to the selection of a design FPR of 1.4 for the aircraft. The airframe is designed to minimize weight and drag during the low altitude high speed leg of the mission hence the wing features are aspect ratio 4.5, wing leading edge sweep of 36 degrees, 15.5 percent thickness and a relatively high takeoff wing loading of 126.4 lb/ft<sup>2</sup>. Winglets are added to provide improved effective aspect ratio for

the high altitude cruise without adding greatly to the wetted area. These features combine to give the vehicle a relatively high optimum cruise speed

FANS:	TWO-STAGE (VTO)
FPR:	1.4
FOLDED SPAN:	17.3 FT
AR:	4.5
SW:	230 SQ FT
(W / S) STOL:	126.4
CRUISE SPEED:	0.8 M
TOGW:	<b>29,070 LB</b>
PROPULSION:	5,775 LB
STRUCTURE:	7,155 LB
EQUIPMENT:	4,730 LB
USEFUL LOAD:	1,960 LB
FUEL:	9,450 LB

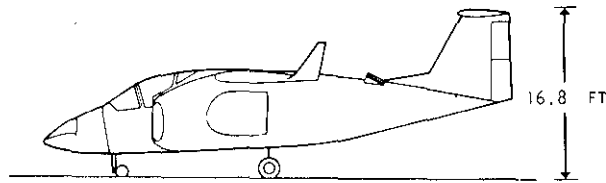
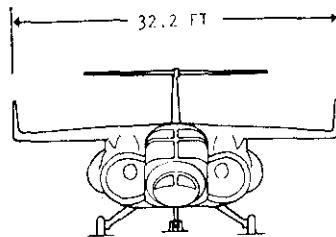
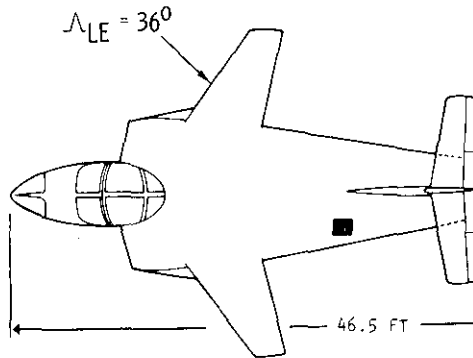

Figure 30. Optimized CSAR Aircraft Design Brief

of about 460 knots at altitude which would provide a significant improvement in rescue response time compared to the helicopters currently assigned to this mission. The takeoff weight required to meet the design mission is 29,070 pounds.

## Surveillance (SURV) Aircraft

The design brief of the optimized surveillance mission aircraft is shown in figure 31. The surveillance mission requirement dictates that the

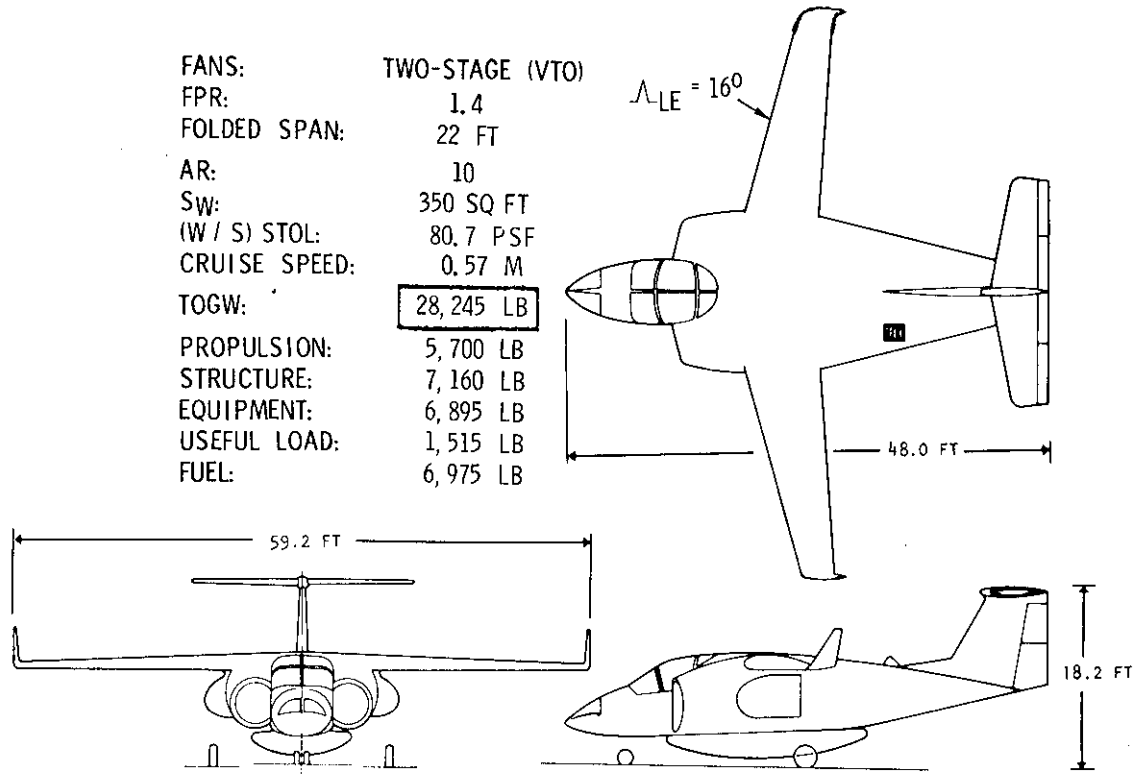

Figure 31. Optimized Surveillance Aircraft Design Brief

aircraft be designed for efficient loiter at high altitude to maximize the effectiveness of its radar. The wing design is therefore characterized by low wing loading, high aspect ratio with winglets and a thickness of 18 percent. A design fan pressure ratio of 1.4 was selected to provide adequate loiter thrust at the selected 35,000 foot altitude condition. Cruise speed is a modest 328 knots but high cruise speed is not a major requirement for the aircraft. Takeoff gross weight on the design mission is 28,245 pounds.



## Surface Attack (SA) Aircraft

The optimum surface attack configuration design brief is presented in figure 32. The surface attack mission has legs similar to the other design

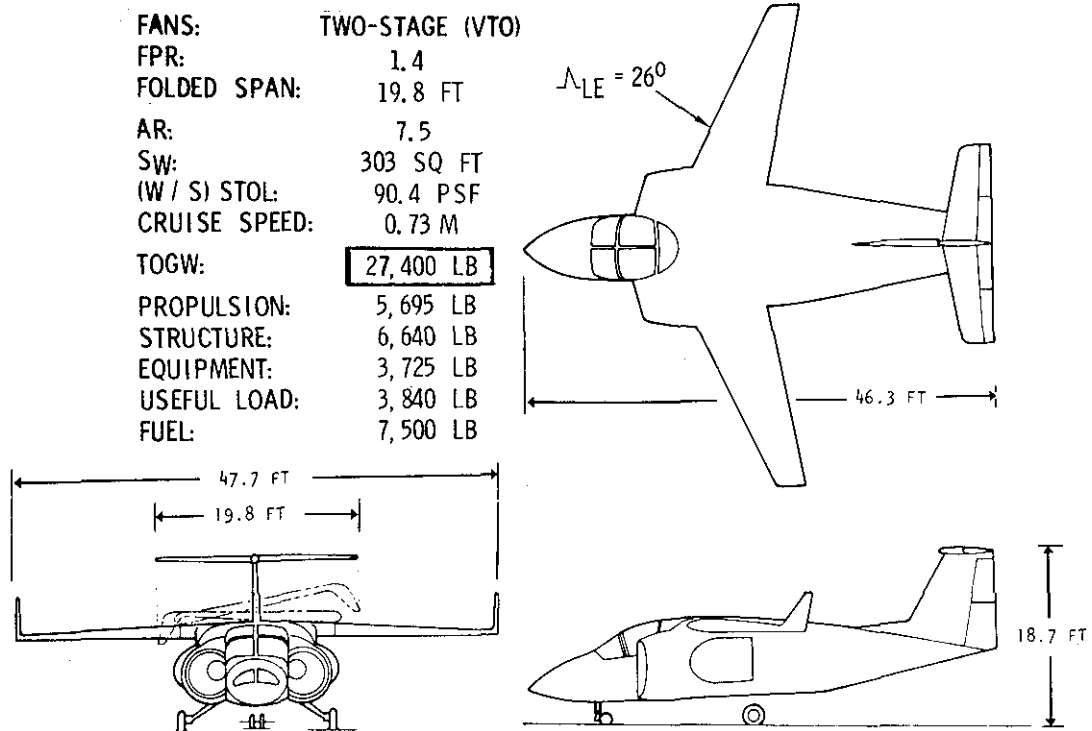

Figure 32. Optimized Surface Attack Aircraft Design Brief

missions but generally of a less demanding nature than the extremes noted in the other missions. The cruise requirement is for 300 nautical miles, all at high altitude; and the loiter is only for two hours at 20,000 feet. The payload, crew and mission equipment weight requirement is a modest 4595 pounds. These requirements dictate an airplane that is close to midway between the extremes of the requirements of the other missions, hence, it has a 15 percent thick 7.5 aspect ratio wing with winglets and a 1.4 FPR design fan pressure ratio. The cruise speed is 404 knots. The takeoff weight required is 27,400 pounds.

Because of their light takeoff gross weights, approximately 3000 to 5000 pounds less than the corresponding multimission aircraft configuration, the

optimized aircraft would be expected to have much better VTOL capability than the multi-mission aircraft. In particular, the optimum surveillance and surface attack aircraft would have excellent VTOL capability because their SL/90°F static thrust-to-weight ratios are of the order of 1.0 at their design mission takeoff weights.

## PROPULSION TECHNOLOGY

The General Electric J97 gas generator was selected to power a variety of different lift/cruise fan designs using the same basic technology for this V/STOL aircraft application study. The basic lift/cruise fan characteristics and performance were obtained from reference 5. Lift/cruise fan data in this reference are presented for both single and two stage fans designed for both cruise and VTO conditions powered by the General Electric J101 gas generator. The single stage fans were designed for a fan pressure ratio range of 1.2 to 1.5, and the two stage fans were designed for a fan pressure ratio range of 1.3 to 1.7. Since the J101 gas generator discharge pressures and temperatures are similar to those of the J97 gas generator (see Table 5), corresponding fan data for the J97 gas generator were estimated by scaling the J101 data to the J97 size. Using a scale factor of 54.5% results in the scaled J101 data shown in Table 5. All fan weights, thrusts and dimensions used in this study were correspondingly scaled to match with the J97 size gas generator. The uninstalled performance data of the scaled J101 data matches the J97 data within 0.5%. Where J97 turbojet thrust was used in the study, the basic J97 gas generator characteristics were used directly. The scaled J101 data was used extensively in the study because it covered all flight regions of interest and a variety of fan types and design fan pressure ratios. Available J97 data was very limited with respect to flight region coverage and fan design options considered.

Table 5

### COMPARISON OF J97 AND J101 PROPULSION SYSTEM UNINSTALLED CHARACTERISTICS

	<u>J101</u>	<u>J97</u>	<u>Scaled J101</u>
Airflow (nom), lb/sec	127.0	69.2	69.2
Gas Flow (nom), lb/sec	129.3	70.54	70.5
Exhaust Temp (nom), °F	1313	1375	1313
Exhaust Press (nom), PSIA	54.6	52.9	54.6
Thrust (Turbojet), lb	9924	5270	5409
Weight, lb	1480	720	720
Gas Horsepower, HP	24820	13450	13527
HP/Airflow, HP/(lb/sec)	195	194	195

#### Gas Generator

The General Electric J97 gas generator is an axial flow, single rotor turbojet gas generator which incorporates a fourteen stage compressor driven by a two stage turbine as shown in figure 33. Variable stators are provided.

INLET AIRFLOW	70.0 LB/SEC
PRESSURE RATIO	14, :1
TURBINE INLET TEMPERATURE	2040°F
DRY THRUST	5270 LB
DRY WEIGHT	739 LB
THRUST/WEIGHT	7.1
LENGTH	66 IN.
MAXIMUM DIAMETER	25 IN.
INLET DIAMETER	21.3 IN.

Figure 33. J97-GE-100 Gas Generator Characteristics

for the first six compressor stages and the first turbine stage is air cooled. The J97 gas generator develops an overall pressure ratio of 14 to 1, has a design turbine inlet temperature of 2040°F, and produces a rated gas horsepower per pound per second of airflow of 194. Growth versions of the J97 gas generator providing up to 16.6% increase in airflow and 14.7% in fan static thrust were considered during the study but were not required to meet the requirements of the study.

#### Lift/Cruise Fans

The lift/cruise fans used in this study included both single and two-stage fans suitable for military applications as shown in figure 34. Some of the fans were designed strictly for cruise and others were designed for

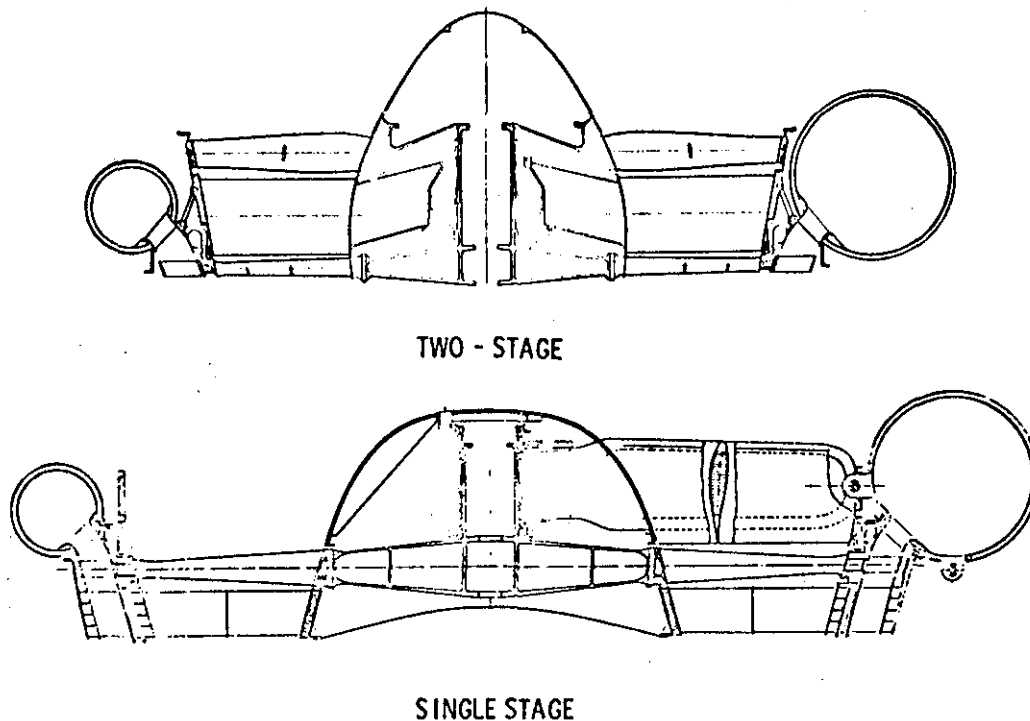

Figure 34. Typical Single And Two-Stage Military Lift/Cruise Fans

various VTO hover control requirements as well as cruise. Fans designed for cruise were considered to provide a zero thrust margin above their nominal thrust ratings during the VTO mode with a 360° operating scroll arc, but were capable of providing a 20% thrust margin at Intermediate Power, SL/90°F, when operating with a 240° scroll arc. The fans designed for VTO were also capable of providing about a 20% thrust margin at Intermediate Power SL/90°F, during the VTO mode with a 360° operating scroll arc. The energy transfer control (ETC) characteristics used for the fans which were designed for VTO are shown in figure 35.

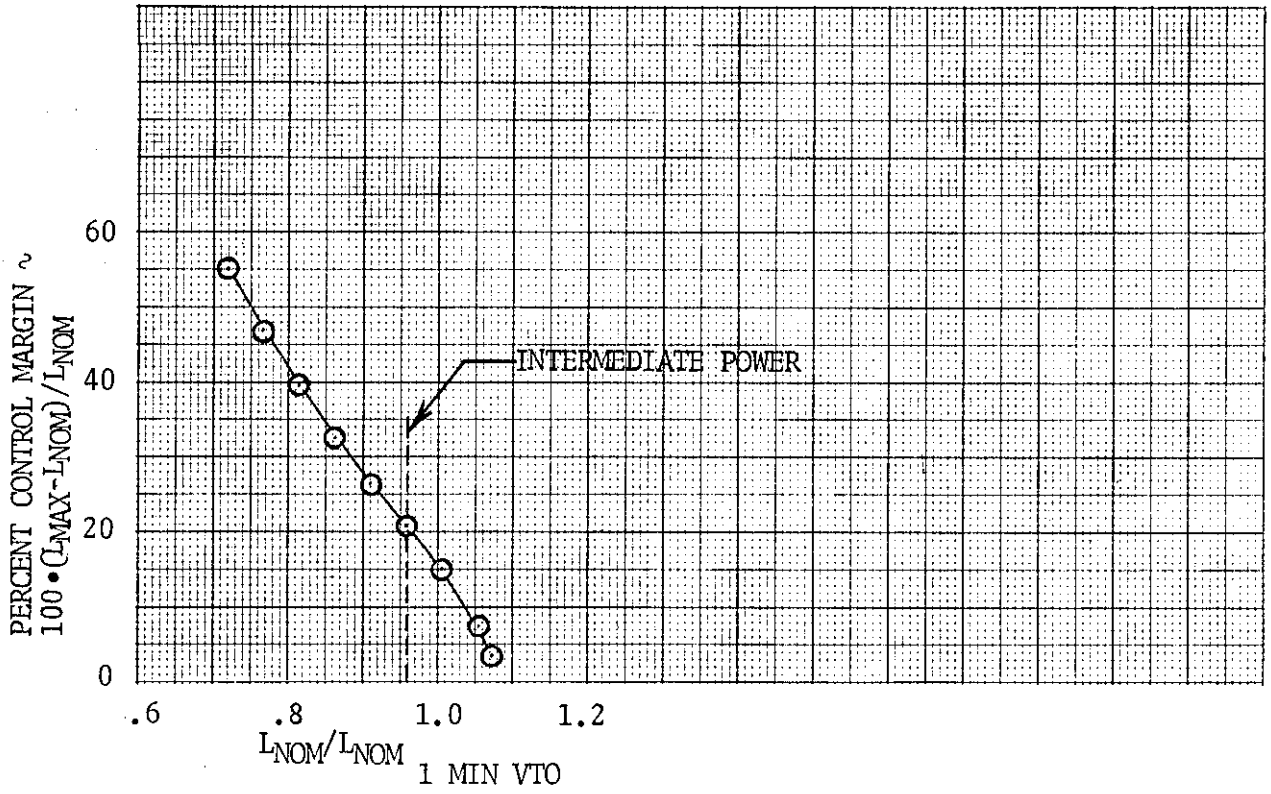

Figure 35. J97 ETC Control Characteristics

## TRADE STUDIES

Trade studies were performed at several points during the study to direct the selection of appropriate concepts and features of the aircraft configurations. Identification of these studies and brief summaries of the results are discussed under two broad categories: (1) propulsion system studies and (2) airframe concept studies.

### Propulsion System Studies

At the initiation of the study, the contractor had two independently developed propulsion system approaches defined that had promising characteristics relative to the study mission applications. One approach used three 1.3 FPR cruise design fans with two gas generators and the other approach used two 1.3 FPR VTO design fans with two gas generators. The three fan system used a lift fan in the nose of the airplane and two lift-cruise fans with integrated single swivel nozzles on either side of the fuselage just aft of the wing trailing edge. Hover control was accomplished by use of the energy transfer control (ETC) concept with part arc operation of the fans. The fans of the two fan system were placed on either side of the fuselage beneath the wings with the integrated single swivel nozzles located such that they could direct thrust straight down near the CG of the airplane for VTOL operations. ETC between the main fans and a small APU driven pitch fan in the tail of the airplane provided hover control for the two fan system. These alternate propulsion system arrangements had been installed in an otherwise identical airframe concept consisting of a high mounted 7.5 aspect ratio supercritical wing with  $16^\circ$  of leading edge sweep and 15% thickness ratio. The fuselages were sized to provide adequate space for VOD mission volume requirements and the empennage consisted of a conventional twin, or "H", tail arrangement.

Table 6 and figure 36 present the results of the analysis and comparison of characteristics of the two propulsion system approaches. The upper portion of Table 6 presents the analysis and comparison of the aircraft configuration concepts using the two alternate propulsion system approaches prior to insertion into computer synthesis programs for wingloading optimization and sizing to the individual mission requirements. This data shows that the two configurations show little differences other than the three fan propulsion system installation is about 650 pounds heavier than the two fan system and an additional 145 pounds of airframe structure is required to enclose the three fan system relative to the two fan system.

The bottom of Table 6 compares the STOL takeoff gross weight and

Table 6. 2-FAN VS 3-FAN CONFIGURATION COMPARISON

PARAMETER	2 FAN/2GG	3 FAN/2GG	DIFFERENCE
<u>WEITTED AREA</u>			
BODY, CANOPY & NACELLES	1,432	1,464	
EXP. WING	355	382	
EXP. H TAIL	210	188	
EXP. V TAIL	<u>202</u>	<u>202</u>	
TOTALS	2,199	2,236	+37 (1.68%)
<u>DIMENSIONS</u>			
LENGTH	50 FT	50 FT	
HEIGHT	15.25 FT	15.25 FT	
FOLDED SPAN	22.25 FT	22.25 FT	
<u>WEIGHTS:</u>			
STRUCTURE	7,755	7,900	+145
PROPULSION	5,400	6,050	+650
EQUIPMENT	<u>6,015</u>	<u>6,015</u>	<u>0</u>
TOTAL EMPTY WT	19,170	19,965	+795
OPERATING WT EMPTY	20,570	21,365	+795
WING FUEL (JP-5)	7,740	7,740	0
PAYLOAD	<u>2,775</u>	<u>2,775</u>	<u>0</u>
TOGW	31,085	31,880	+795
<hr/>			
<u>TOGW/ (W/S)</u>			
ASW	33,540/97.5	34,600/90	+1060
VOD	34,900/104	35,290/100	+390
CSAR*	31,200/140	31,400/170	+200
SURV	28,000/77	29,350/65	+1350
SA	31,295/107.5	32,470/120	+1175

\* INADEQUATE INTERNAL WING FUEL VOLUME



wingloading required of the minimum weight airplanes of each concept to do each individual mission. The initial 7.5 aspect ratio, 15 percent thick wing did not provide adequate internal wing fuel volume to contain all the mission fuel on the CSAR mission at the minimum weight sizing point for either propulsion concept. The comparison of the required takeoff weights shows that the three fan system approach results in airplanes up to 1350 pounds heavier than the aircraft using the two fan concept.

Figure 36 presents a qualitative comparative assessment of the likely VTOL reingestion characteristics of the two fan and three fan configurations.

Illustrated on the left of figure 36 is the expected two fan system

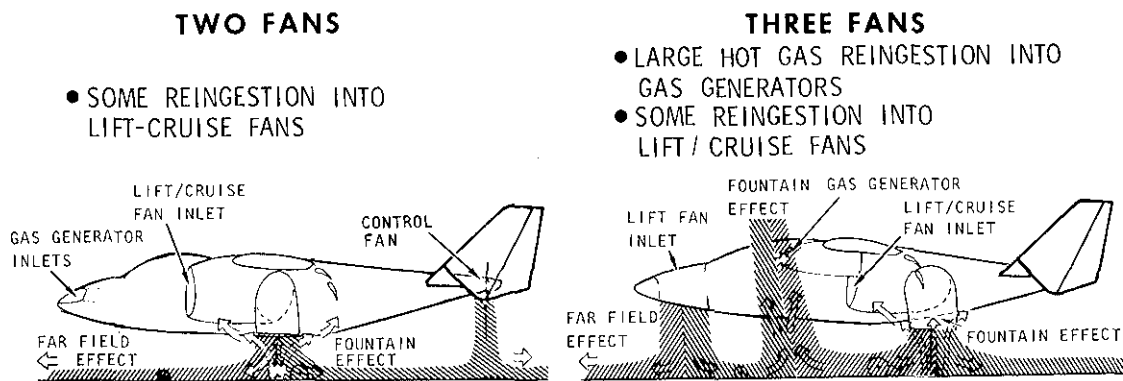

Figure 36. Two and Three Fan Configuration VTOL Reingestion Characteristics

characteristic to build up a positive pressure fountain effect on the under-surface of the fuselage between the two nozzles and to provide rising warm air upward along the fuselage just forward and aft of the wing. The major portion of the nozzle exhaust, however, will attach itself to the ground and move outward away from the aircraft until its energy is dissipated and it becomes a part of the far field environment of the aircraft. The pitch control fan flow, being of lower momentum than the main exhausts is swept away from the aircraft as it contacts the main exhaust flow along the ground. Because of the location of the fan inlets ahead of the wing/fuselage juncture and the nose location of the gas generator inlets, it is anticipated that relatively little hot gas reingestion will be experienced by the fans with almost no reingestion by the gas generators. Reingestion by the fans is less detrimental to propulsion system performance than reingestion by the gas generators.

The right hand portion of figure 36 shows the expected reingestion characteristics of the three fan system. A positive pressure fountain is expected between the two lift-cruise exhausts similar to the two fan arrangement. However, because the momentum of the exhaust flow of the nose lift fan is about equal to the momentum of the flow of the other fans, a second fountain would be expected to develop on the centerline of the airplane approximately one-third of the distance between the fans and aft of the front fan. This secondary fountain is in a position that would likely cause hot gas reingestion into the gas generator inlets. The rising air from the two fountains would be likely to provide significant hot gas reingestion into the gas generators and also some directly into the fan inlets.

A comparison of the likely induced STOL lift augmentation of the two systems showed that the three fan system might contribute an increase of about 10% in STOL takeoff lift whereas the two fan system might decrease the lift by about 3.5% if no remedial configuration features were adapted. These levels of lift effects, while potentially relevant, still imply that the STOL lift will be primarily dictated by the lift efficiency of the basic wing/flap arrangement.

A qualitative assessment of fan inlet flow distortion characteristics of the two systems was also made. The flow into the lift-cruise fan installations of both systems should be relatively similar. The two fan system would experience less disturbance from the gas generator installation but would not benefit from the flow straightening of an overhanging lower wing surface by comparison with the three fan system. Flow disturbances coming from downstream of the fans would be about equal for the two systems. The major difference in the distortion characteristics of the two systems is reflected by the differences caused by the nose fan installation of the three fan system. In the nose lift fan installation, cross-flow effects at high forward speeds are expected to create significantly higher levels of distortion of the flow into the nose fan relative to the distortion levels experienced by the lift-cruise fans. These distortion effects are such that significant reduction in thrust of the nose lift fan would be expected as forward speed is increased.

A review of the above comparisons of the two fan vs. the three fan approach indicated that the likely 1000 pound lower takeoff weight and other beneficial operating characteristics of the two fan system generally would tend to provide a vehicle of lighter weight and better operating characteristics than a vehicle built with the three fan system. On the strength of this analysis, the two fan system was selected for further development in the study.

During the study, the original engine out landing criteria were reviewed and were found to provide an inadequate level of safety. A new guideline to provide a T/W of 1.0 for the emergency landing case was adopted. To meet the new criteria, a series of potential alternatives to pursue within the basic two fan propulsion concept were examined: (1) two fan/2GG plus pitch fan vs two fan/3GG, (2) basic vs. growth J97, (3) plenum chamber burning and (4) water injection.

Based on the significance of propulsion system installed T/W as a major parameter affecting the vehicle takeoff weight, as discussed in the following subsection of the report, and likely cost consequences, the potential propulsion system alternatives were evaluated and ranked. The addition of a third gas generator was identified as the most desirable means to add additional emergency thrust because of its high emergency thrust-to-weight ratio and negligible impact on gas generator development costs. Emergency only water injection was rated as the second most desirable alternative because of the high system installed thrust-to-weight ratio and relatively small propulsion system development cost impact. Use of a growth J97 was ranked third in preference to provide additional thrust because of the marginal increase in installed thrust-to-weight ratio and increased nacelle weight and drag and increment to propulsion system development costs. Plenum chamber burning, both upstream and downstream of the fan were eliminated because of their significant impact on the fan design criteria and propulsion system installation requirements respectively. Burning upstream of the fan would significantly increase the fan design problems and technology required because of the significantly higher gas flow temperatures. Burning downstream of the fan would significantly increase the diameter and length of the diffuser duct in the fan exhaust to provide a suitable combustion chamber and would also increase the thermal design requirements.

A smaller vectoring nozzle with internal turning vanes similar to the current Harrier lift-cruise nozzles was evaluated relative to the integrated single swivel nozzle concept. The smaller nozzle approach was determined to be unlikely to produce a net improvement because the additional turning and pressure losses in the low pressure flow were expected to overpower the gains due to a lighter weight nozzle.

The two fan/three gas generator system was identified as having the capability to allow loiters with one gas generator driving two fans if this was desirable. Figure 37 shows the result of a trade study that showed the potential. Loiter on one gas generator driving two fans reduces the loiter SFC significantly because it causes each fan to operate at an effectively

higher bypass ratio and simultaneously causes the gas generator to operate at a higher percent of its rated capacity where it is also more efficient. The drag of the stopped gas generator reduces the benefit shown somewhat

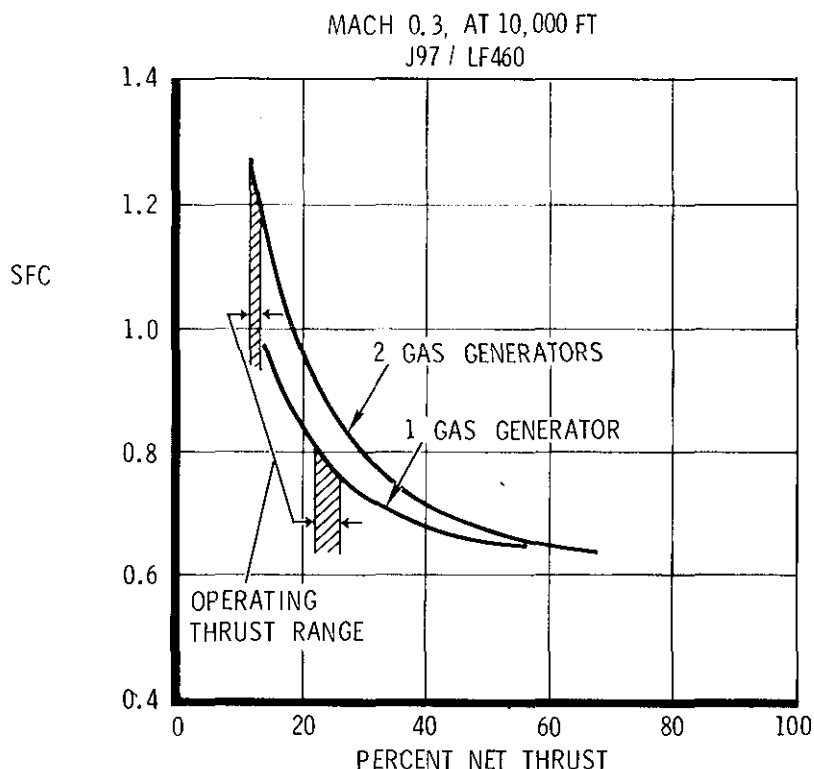

Figure 37. Loiter SFC Comparison - One vs Two Gas Generators

but does not detract from an overall benefit. An onboard APU that supplies bleed air for avionics environmental control is continuously available to start another gas generator if the operating unit fails.

The selection of fan type, i.e., single versus two stage and design fan pressure ratio, was made according to the individual mission requirements consistent with existing study guidelines. The fan system characteristics that are important in the selection of appropriate systems are presented in figures 38 through 41.

Figure 38 shows representative sea level static thrust characteristics for two fans driven from the flow of one and two gas generators operating at various power settings as a function of fan design fan pressure ratio. These characteristics are important for STOL and VTOL takeoffs and mission hover legs.

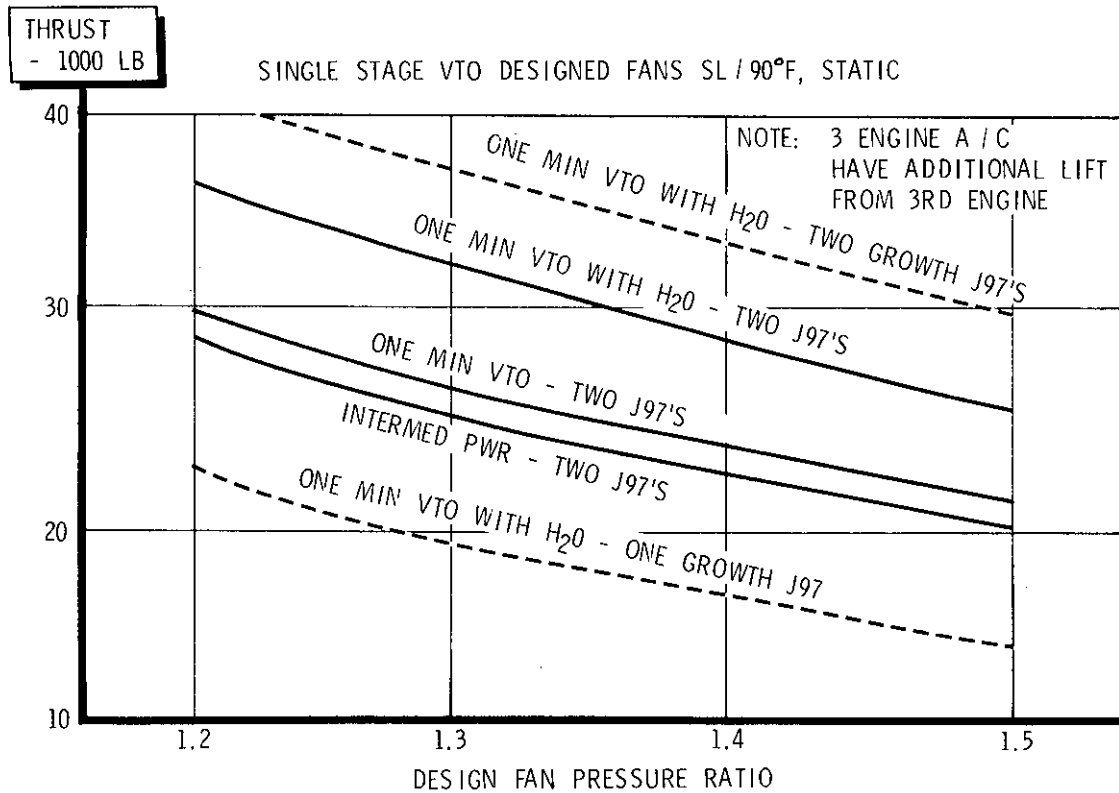

Figure 38. Static Thrust of Propulsion Systems vs Design FPR

Figure 39 shows takeoff and representative cruise T/W ratio characteristics of the propulsion systems as a function of design FPR. The takeoff thrust rating is the SL/90°F thrust.

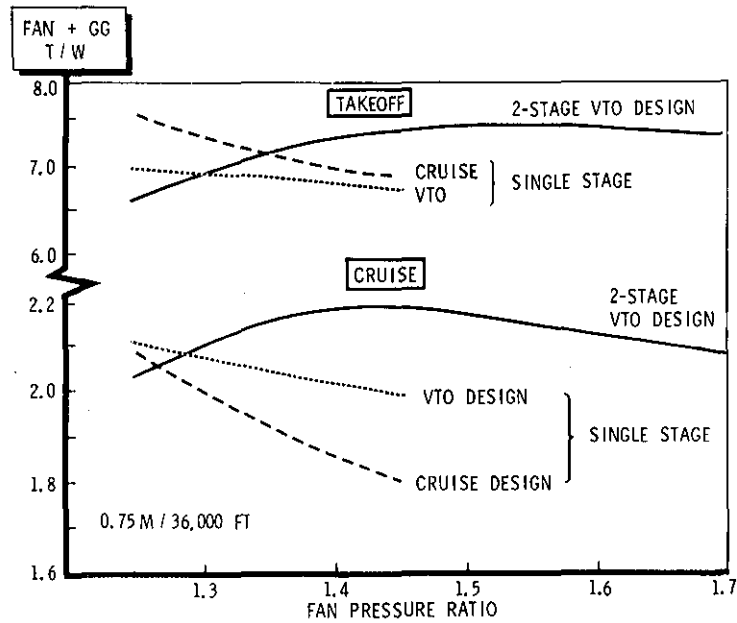

Figure 39. Takeoff and Cruise Thrust to Weight Ratio Characteristics of Lift-Cruise Fan Systems

Figure 40 presents representative cruise SFC characteristics of candidate lift-cruise fan systems. Notice that the lower design fan pressure ratio systems tend to provide lower SFC's.

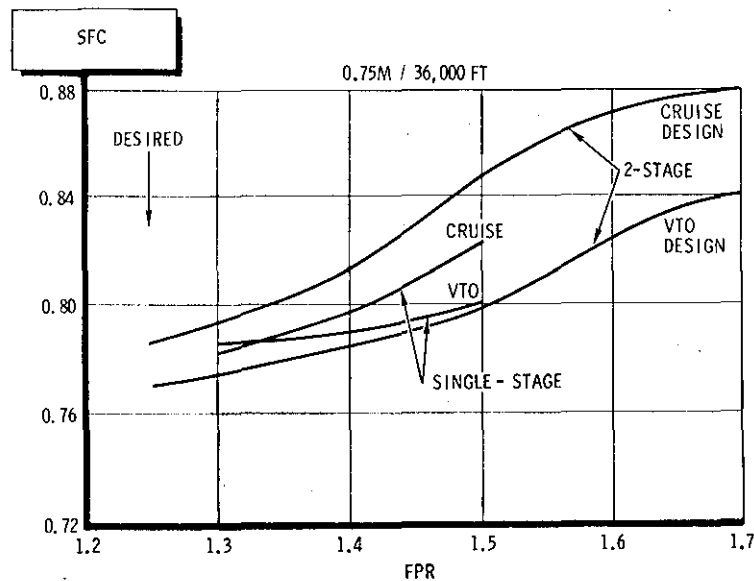

Figure 40. Lift-Fan System Cruise SFC Characteristics

Figure 41 presents the fan tip diameters of candidate lift-cruise fan systems as a function of design FPR. This parameter is very powerful in establishing the total installed weight and drag consequences of the selection of a fan system of a given design FPR. This occurs because the outer scroll dimensions and hence the nacelle outer dimensions are frequently directly related to the fan tip diameter. As the design speed and range increase, the beneficial combined effect of fan system installed thrust-to-weight ratio and smaller fan dimensions (fan tip diameter) tend to overpower the significance of the higher SFC's noted in figure 40 at the higher design FPR's.

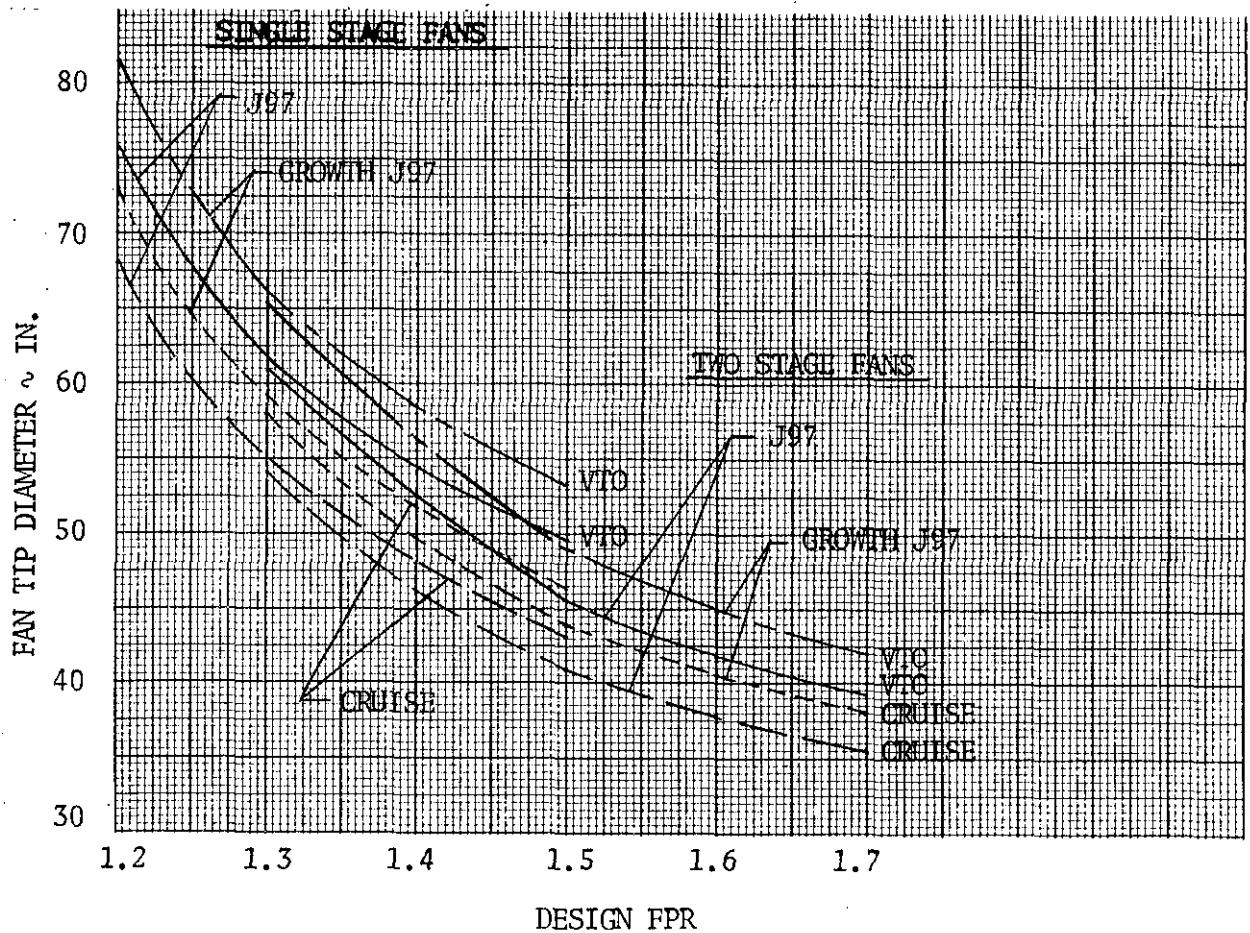

Figure 41. Fan Tip Diameter vs Fan Type and Design FPR

During the development of the optimized aircraft for each of the design missions, the selection of fan type was not constrained by guideline other than that a technology developable by 1985 be used. The lighter weight and reduced size of the two stage fans led to their selection for the optimized aircraft. During development of the compromise multi-mission aircraft configuration, the applicable study guideline was to minimize technical risk in the propulsion system development. Thus the selection of design fan pressure ratio for the optimized aircraft varied significantly, covering the range from 1.3 to 1.5. In selecting a design fan pressure ratio for the compromise multi-mission aircraft, the requirement to meet the takeoff requirements and the CSAR mid-mission hover with heavier, non-optimum aircraft drove the selection of the design fan pressure ratio to the low side where static thrust is best. Also, a design FPR of 1.3 was identified as best for the ASW aircraft which was the largest of the individually optimized aircraft. A design fan pressure ratio of 1.3 was thus selected for the multimission aircraft.



## Airframe Concept Studies

Based on the propulsion arrangement studies reported above, a two-fan propulsion system concept was adopted for the study. The airframe concept introduced, based on prior contractor studies, was a high mounted, low sweep, moderate aspect ratio wing combined with a conventional twin, or "H", tail. The aft fuselage contours were dictated by the aerodynamic shape required to provide smooth afterbody lines behind the fan and the integrated single swivel nozzle system nested in the fuselage/wing root juncture. This arrangement of the propulsion system elements minimized the wetted area required and simultaneously provided generous volume in the aft fuselage for alternate equipment arrangements to meet multi-mission requirements. Figure 42 illustrates the major features of the concept basepoint.

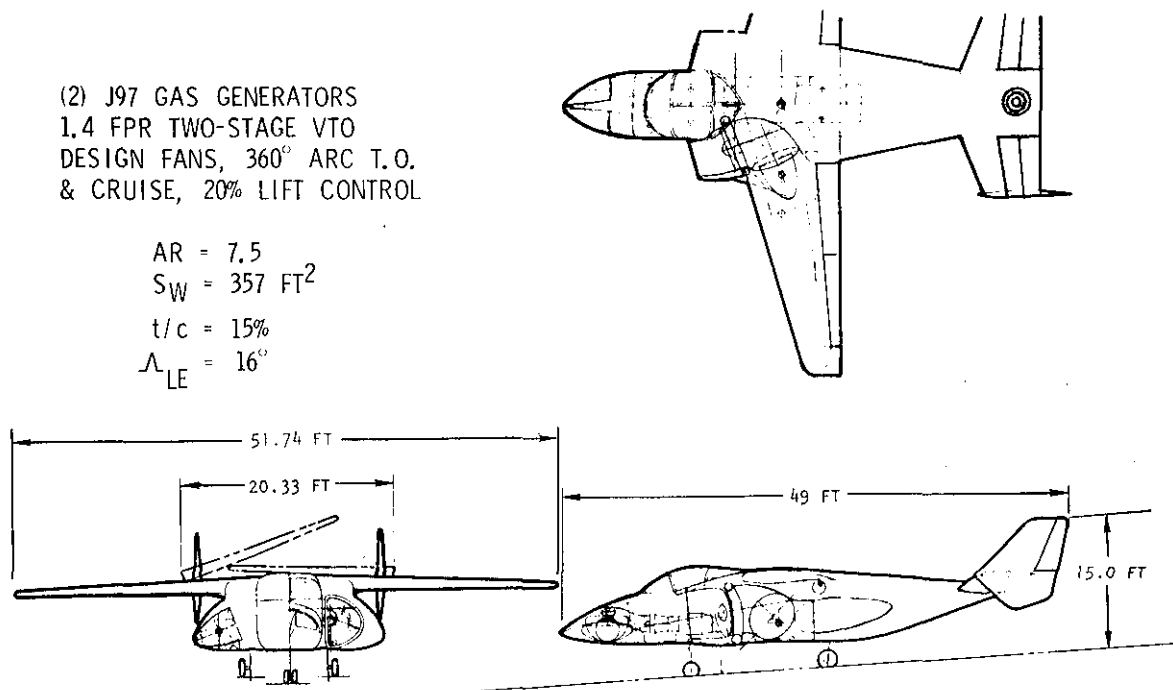

Figure 42. Two Fan/Two Gas Generator Multi-Purpose Aircraft  
Concept - No VOD Requirements

The aircraft configuration illustrated in figure 42 featured a minimum size fuselage dictated primarily by efficient propulsion system integration. As such, it did not provide for a cargo loading ramp or the cargo bay cross-section requirements of the VOD aircraft mission. This early aircraft used a small APU driven variable pitch fan, mounted in the tail, for pitch trim

and attitude control. The 1.4 FPR two-stage VTO design fans of the basepoint propulsion system were arbitrarily selected by the contractor as a convenient representative lift-cruise system of the type believed applicable to the study missions. A companion aircraft configuration, similar in most respects to the basepoint airplane of figure 42, but utilizing a fuselage designed to meet the VOD mission requirements was also synthesized as a secondary study basepoint.

The two basepoint aircraft concept definitions indicated above were inserted into an aircraft, synthesis and performance evaluation computer program for evaluation on the five study missions. The initial phase of the study was directed to defining the required aircraft takeoff gross weight sensitivity to changes in the major design features of the basepoint aircraft as a function of the design mission. Figure 43 shows typical results obtained during the study of the ASW mission.

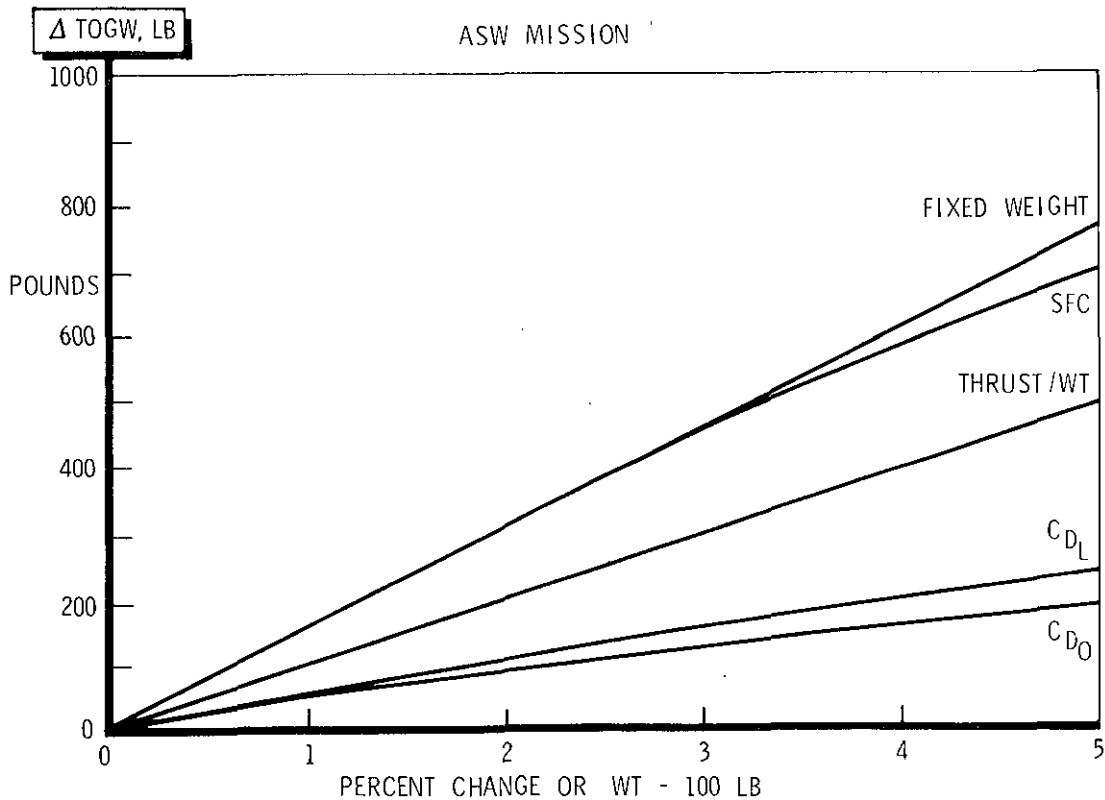

Figure 43. Aircraft TOGW Sensitivity to Major Design Parameters

The data of figure 43 indicate that a fixed weight increase of 500 pounds to the air vehicle would increase the ASW mission takeoff weight by about 770.

pounds, this indicates a takeoff weight growth factor of 1.54. Similarly, changes of 5 percent in SFC would vary the required takeoff weight by 700 pounds, 5% change in propulsion system installed T/W ratio would cause a 490 pound  $\Delta$ TOGW and 5% change in drag due to lift or parasite drag would cause 240 and 190 pound changes in takeoff weight respectively. By careful consideration of these trends, it is possible to identify the likely TOGW effect of candidate changes to the basepoint airplane and thereby identify the most beneficial direction that changes should be made to optimize the basepoint concept for the particular mission. In the case of the ASW mission illustrated, it is apparent that minimization of SFC would be indicated and also that drag due to lift was relatively more important than wetted area. Fixed weight and propulsion system T/W ratio were also significant parameters such that any proposed change that affected them would have to be carefully considered.

Similar to the evaluation of the ASW mission presented above, the aircraft takeoff weight sensitivity to major design variables was surveyed for all the design missions. Table 7 presents the results of this early sensitivity study. Consideration of the data of Table 7 indicate that

Table 7. SUMMARY OF TOGW SENSITIVITY TO DESIGN PARAMETERS

MISSION	GROWTH FACTOR	FIXED WEIGHT $\Delta$ 500 LB	SFC $\Delta$ 5%	PROP. T/W $\Delta$ 5%	$C_{D_L}$ $\Delta$ 5%	$C_{D_O}$ $\Delta$ 5%
ASW	1.54	770	700	490	240	190
VOD	1.55	775	790	610	220	300
CSAR	1.46	730	670	510	130	260
SA	1.52	760	560	400	165	190
SURV	2.00	1000	560	410	210	155

the system takeoff weight growth factor remains close to 1.5 for all missions except the surveillance mission where it is approximately 2.0. These low growth factors are a result of the fact that a fixed propulsion system size, established by the J97 gas generator, is established as a constraint on the system design. The takeoff weight sensitivity varies with a given design parameter as a function of the design mission. The trends are somewhat similar for many of the missions but some switching of design priorities are noted. For example, drag due to lift is more

important than parasite drag for the ASW and surveillance missions, but the reverse is true for the other missions. It is important to consider all factors simultaneously. For example, a propulsion system that features better T/W ratio with some sacrifice in SFC may still provide a net gain if it also is of smaller size such that it can show simultaneous reduction in parasite drag and nacelle or fuselage fixed weight. The net absolute value of the individual changes due to all effects determines the worth of a proposed configuration revision.

With the general takeoff weight sensitivity of the aircraft established as a function of design variables, matrices of potential wing geometry changes and propulsion system changes, as discussed in the preceding subsection of the report, were prepared for consideration. The wing geometry data assembled encompassed the following variables:

Aspect Ratio:	3.0 to 10.0
Leading Edge Sweep:	16° to 36°
Thickness:	10% to 18%
Wing Area:	200 to 800 ft <sup>2</sup>

The additional design data assembled for the wing design matrix included structural weight vs. design gross weight, exposed wetted area, drag and fuel volume. Using this data and the guidance provided by the sensitivity studies presented above, incremental design changes to the basepoint aircraft were made to adapt and optimize them for each mission. As a result of these exercises, preliminary optimized aircraft evolved from the original basepoints for each mission.

Simultaneously with the preliminary aircraft mission optimizations, a series of additional trade studies were performed to modify and improve the basic basepoint aircraft concept. These studies consisted of the consideration of the emerging NASA winglet technology, alternate fuselage design concepts, empennage studies, evaluation of internal vs. external stores, alternate surveillance antenna concepts, and cockpit visibility improvement studies. A summary of the results of these activities is presented below.

Figure 44 shows the results of the estimated potential effects of the employment of winglet technology to the study aircraft. The data indicate

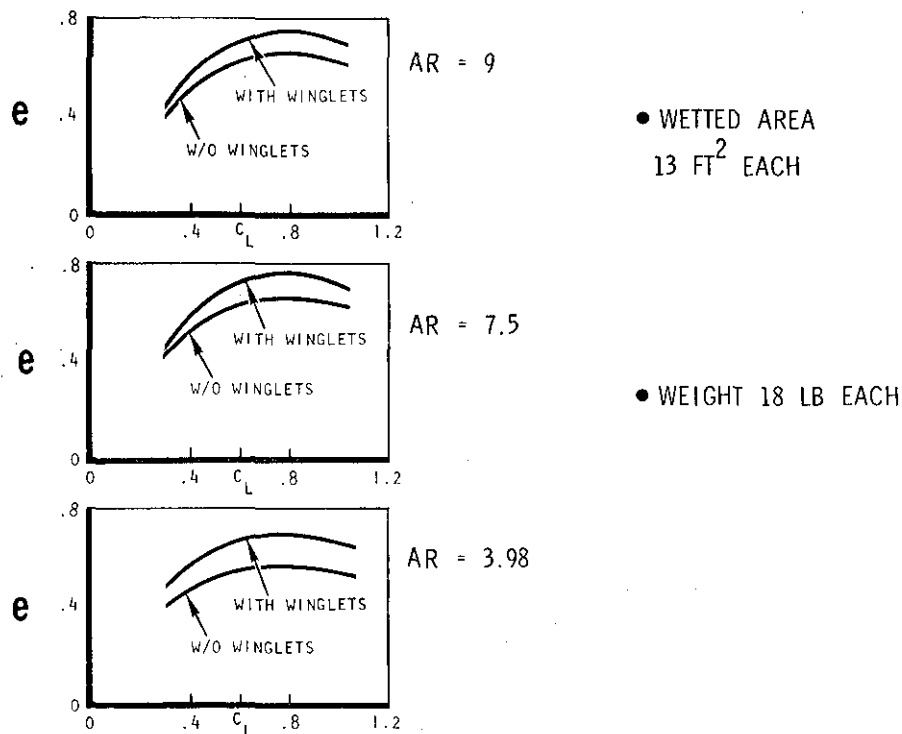

Figure 44. Estimated Potential Winglet Design & Performance Characteristics

that potentially dramatic improvements in airplane drag due to lift can be obtained with comparatively small wetted area and weight penalties with properly designed winglets. Achievement of the indicated levels requires a carefully coordinated basic wing and winglet design. Only through careful tailoring of the total wing to the winglet philosophy can the indicated levels of improvement be achieved.

Alternate fuselage cross-section design concepts were investigated as illustrated in figure 45. The objective of the study was to identify a

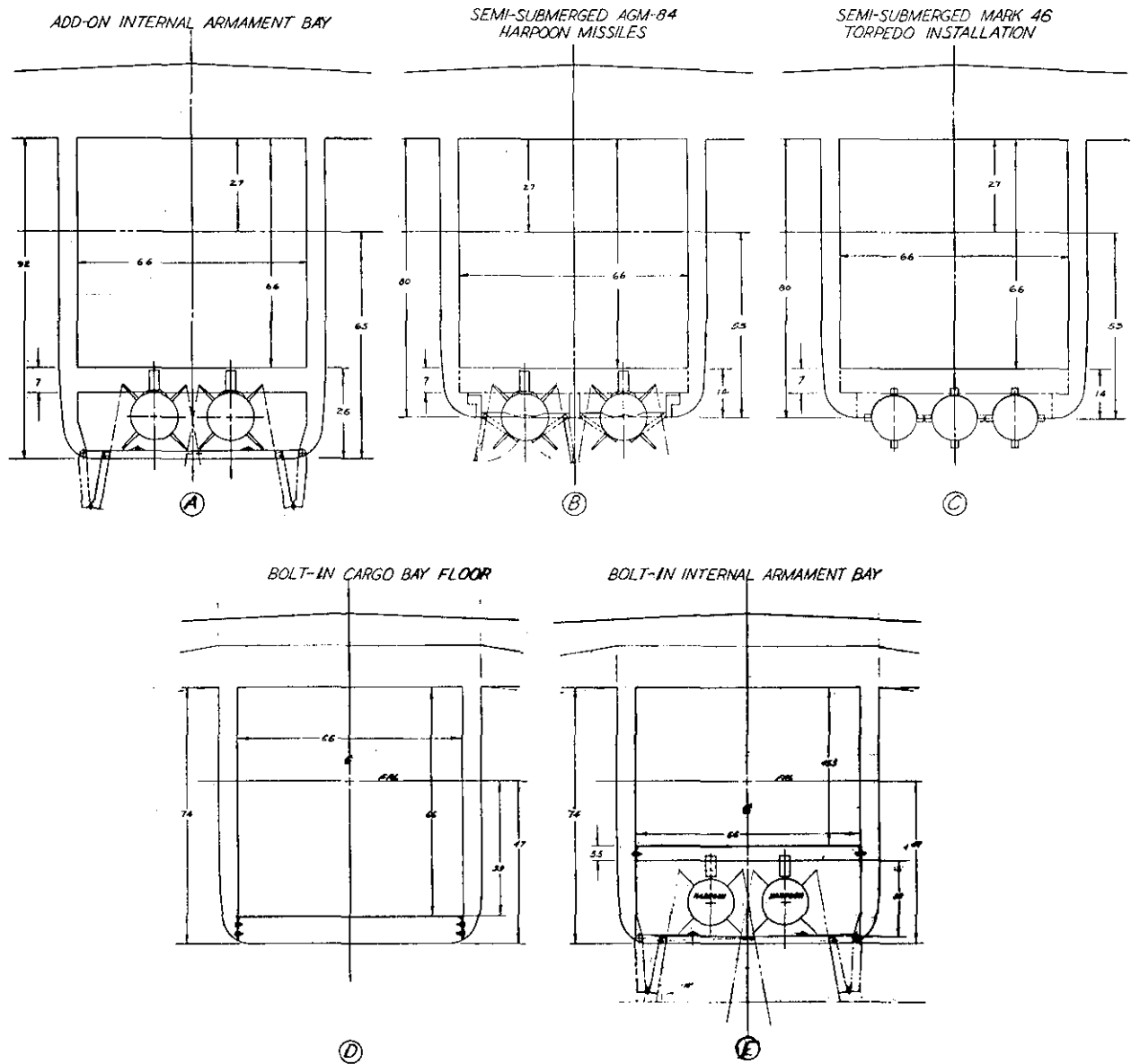

Figure 45. Candidate Fuselage Cross-Section Designs

fuselage design concept that would lead to maximum commonality and design efficiency of potential multi-mission aircraft.

Sketch A of figure 45 shows a concept where a fuselage with maximum commonality among the mission aircraft is featured. The cargo bay cavity required to satisfy the VOD mission requirements (66" by 66") is provided with an internal armament bay integrally built into the fuselage below.

This concept requires a fairly large fuselage depth. Sketches B and C present a concept where the fuselage maximum depth and weight are reduced by using semi-buried stores installations instead of an internal armament bay. Sketches D and E present a concept where a basic fuselage depth is established by the VOD cargo bay requirements alone. An alternate permanent modularized bolt-in bottom approach is used to facilitate the requirements of the several missions. The lower side frames are the only portion of the fuselage structure that must carry design compromise weight penalties for the multi-mission application. The overall vehicle weight and drag would be minimized through the use of this concept. This is the preferred approach that was selected for employment on the recommended multi-mission aircraft concept.

An empennage study was undertaken as summarized in figure 46. By reason of minimum weight and maximum control effectiveness over a large range of angles of attack, the T-tail was selected as the most promising

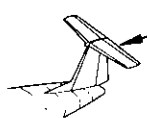
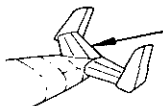
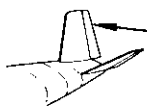
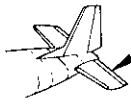
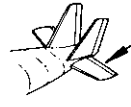
CONFIGURATION		REMARKS
T		<ul style="list-style-type: none"> <li>• GOOD CONTROL EFFECTIVENESS THROUGHOUT OPER <math>\alpha</math>-RANGE</li> <li>• 2ND LOWEST WETTED AREA</li> <li>• GOOD SPOTTING CHARACTERISTICS</li> </ul>
H		<ul style="list-style-type: none"> <li>• HORIZONTAL &amp; VERTICAL PROXIMITY TO FAN EXHAUST IN CRUISE</li> <li>• BEST CANDIDATE WITH TAIL PITCH FAN</li> </ul>
V		<ul style="list-style-type: none"> <li>• CONTROL CROSS COUPLING PROBLEMS</li> <li>• MINIMUM WETTED AREA</li> <li>• GOOD SPOTTING CHARACTERISTICS</li> </ul>
CONVENTIONAL		<ul style="list-style-type: none"> <li>• 2ND HIGHEST WETTED AREA</li> <li>• HORIZONTAL PROXIMITY TO FAN EXHAUST</li> </ul>
TWIN		<ul style="list-style-type: none"> <li>• MAXIMUM WETTED AREA</li> <li>• HORIZONTAL PROXIMITY TO FAN EXHAUST IN CRUISE</li> </ul>

✓  
SELECTED

Figure 46. Summary of Empennage Design Trade Study

empennage concept if the basic configuration did not require a pitch control fan mounted in the same general area as the vertical stabilizer. The "H"

tail concept would be the preferred concept if significant interference with a tail pitch control fan was a consideration.

A brief review of the potential merit of external store carriage versus the basepoint internal armament provision concept was conducted. This study concluded that because of the aft fuselage fairing required to provide smooth flow around the integrated two-fan propulsion system, little fuselage wetted area could be deleted by designing the configuration for external store carriage. The most promising alternative, that of using semi-buried armament, reduced the net airplane drag by only about one count and would require special environmental provisions to maintain torpedoes within their specified temperature limits. The study concluded the semi-buried or external armament concepts were not really compatible with the two fan/high wing concept and that the basepoint internal armament approach was probably the best operational concept from the total system effectiveness viewpoint.

An alternate top-mounted round rotodome antenna concept was considered versus the unique RI bottom-mounted concept. Except for operational experience, the top-mounted rotodome was rated less desirable with respect to all the design and operational features considered compared to the RI design. For example, it was heavier, had higher drag, caused tail, ejection and wing fold design interferences and had lower radar performance for a given size than the bottom-mounted antenna. Because of its superior characteristics, the RI bottom-mounted antenna was selected for the optimized and multi-mission aircraft surveillance mission configurations.

The cockpit visibility studies identified new windscreen and side canopy geometry that provided cockpit visibility as good as or superior to the CL-84 visibility as a function of the pilot vision azimuth angle. Particular attention was made to provide 20° over the nose vision directly in front of the pilots.

A final wing concept study was made to identify a basic wing design philosophy to use for the multi-mission airplane concept. The wings selected for the optimized aircraft had wide variety of wing geometries. The use of a single wing panel for all missions appeared to present too much of a weight penalty to allow an efficient two fan multi-mission aircraft without development of technologies and optimization techniques beyond the scope of the current preliminary conceptual study. Thus two basic approaches to multiple wing panel concepts were investigated. The first approach considered a basic wing design that could be adapted to each mission by deleting modularized outer panels that were all developed from the same basic wing planform and taper design. This approach would allow common tooling to be used for all wings. The second approach was to build a common wing center section to which an outer panel tailored to



an individual mission or missions could be added as desired. The latter approach allowed tailoring of the wing leading edge sweep and thickness to each mission if desired. The studies conducted indicated that the second approach resulted in an overall fleet of aircraft that could meet all the mission requirements relatively efficiently. Pursuit of this approach identified that with only two basic wing panels (one for the ASW, Surveillance and VOD missions and one for the CSAR and SA missions) all missions could be accomplished. Because of these results the basic center section and dual outer wing panel approach was selected for the multi-purpose airplane.

## CONCLUSIONS

- A two fan/three gas generator lift-cruise fan propulsion system appears to provide the best arrangement to meet all of the mission aircraft requirements at minimum weight.
- A multi-mission aircraft configuration concept with one basic fuselage with internal modifications, a common tail and two outer wing panels can perform the design missions with takeoff weights varying from 32,000 to 39,000 pounds.
- Aircraft individually optimized for each mission separately can be built that will do the design missions for approximately 3000 to 5000 pounds less takeoff weight than the compromise multi-purpose configurations.
- The current J97 gas generator provides sufficient power to perform the required missions with a two fan/three gas generator propulsion system concept.

## REFERENCES

1. R. G. Knight, W. V. Powell, Jr., and J. A. Prizlow, "Conceptual Design Study of a V/STOL Lift-Fan Commercial Short Haul Transport", NASA Contractor Report CR-2185, Prepared by the Rockwell International Corporation Los Angeles Aircraft Division, April 1973.
2. Robert L. Cavage, et al "Conceptual Design of Improved 1985 Remote Lift-Fan V/STOL Commercial Transports", NASA Contractor Report CR 2481 Prepared by Rockwell International Corporation Los Angeles Aircraft Division, January 1975.
3. Robert L. Cavage, et al, "Conceptual Design Study of a Military Oriented Remote Lift-Fan V/STOL Transport", NASA Contractor Report CR-114753, Prepared by Rockwell International Corporation Los Angeles Aircraft Division, July 1974.
4. Anon., "LF460 Detail Design" NASA Contractor Report NASA CR-120787, Prepared by the General Electric Company, September 1971.
5. Anon., "Conceptual Design Studies of Lift/Cruise Fans for Military Transports" NASA Contractor Report NASA CR-134636, Prepared by the General Electric Company, May 1974.