

Science Applications, Inc.
Rolling Meadows, Ill.

Manpower/Cost Estimation Model
Automated Planetary Projects

by

Lawrence D. Kitchen

STAR Abstract

An estimating procedure for predicting the cost of a future planetary mission is described and developed. The model is applicable at a pre-Phase A project level and is based on a detailed level of financial analysis of the planetary and lunar projects for which data were available. The major parameter of expenditure is direct labor hours for all spacecraft subsystem and technical support categories. The model also includes cost saving inheritance factors for estimating follow-on type programs where hardware and design inheritance are evident or expected.

Report No. SAI 1-120-194-C1

MANPOWER/COST ESTIMATION MODEL
Automated Planetary Projects

by

Lawrence D. Kitchen

Science Applications, Inc.
5005 Newport Drive, Suite 305
Rolling Meadows, Illinois 60008

for

Planetary Programs Division
Office of Space Science
NASA Headquarters
Washington, D. C.

Contract No. NASW-2613

March 1975

FOREWORD

This study was performed from February 1974 to February 1975 as part of the work performed by Science Applications, Inc. for the Planetary Programs Division of OSS/NASA under Contract No. NASW-2613. The results are intended to provide NASA planners with reasonably accurate rapid estimates of future planetary missions for planning activities.

TABLE OF CONTENTS

	<u>Page</u>
FOREWORD	ii
1. INTRODUCTION	1
2. FINANCIAL ANALYSIS	1-1
a. Financial Categories	1-12
b. Spacecraft Categories	1-18
c. Manpower Modeling Benefits	1-31
d. Inputs to Modeling Phase	1-34
3. MANPOWER/COST MODEL	2-1
a. Cost Model Outline	2-4
b. Spacecraft and Mission Parameters	2-9
c. Subsystem LER's	2-10
d. Support System LER's	2-22
e. Total Project Cost Estimates	2-38
f. Inheritance	2-41
g. Inheritance Effect on MVM '73 Estimate	2-44
4. SAMPLE MODEL APPLICATIONS	3-1
a. Model Application Summary Results	3-8
APPENDIX	

Manpower/Cost Estimation Model
For Automated Planetary Projects

Introduction

Throughout the 1960's, there has been an increasing awareness in NASA that improved confidence in cost estimates must be achieved. Accordingly, cost estimation models have been developed by the Rand Corporation, IIT Research Institute, General Dynamics, Martin Marietta Corp., Planning Research Corp., Aerospace Corp., amongst others, and in addition each of the NASA centers have improved their internal cost estimation techniques. Also a host of studies have been undertaken to examine specific aspects of spacecraft project costs. In essentially all of the models the basic parameters of expenditures have been dollars themselves, and the details of the financial data have only been of the same order as the model itself. Thus a Phase A model has been based on a Phase A level of financial data.

The manpower/cost estimation model developed here incorporates two significant improvements on past practice. First it is based on a detailed level of financial analysis of over 30 million raw data points which are then compacted by more than three orders of magnitude to the level at which the model is applicable. Second the major parameter of expenditure is manpower (specifically direct labor hours) for all spacecraft subsystem and technical support categories. The resultant model, which is applicable at a pre-Phase A project level is able to provide a mean absolute error of less than fifteen percent for the eight programs comprising the model data base. The model also includes cost saving inheritance factors, broken down in four levels, for estimating follow-on type programs where hardware and design inheritance are evident or expected.

The first section of this document discusses the financial analysis of the eight planetary and lunar projects for which data was available. The second section discusses the manpower and cost estimation model developed from this data. It also describes how inheritance is incorporated into the model. The third section discusses the application of the model to several projects.

The model presented here does not yet embrace a complete span of planetary mission concepts. In particular, modeling of atmosphere probe hardware is based on tenuous data. A consistent methodology for estimating sample return and penetrator mission costs is not included, and a broader data base is desired to enhance the modeling of the labor estimating relationships. Work is currently in progress to improve the model in these and other respects.

SECTION 1

**FINANCIAL
ANALYSIS**

Past Performance of Cost Estimation

Estimating the project costs of planetary missions has long been a difficult task for NASA. The chart on the facing page illustrates the success of previous cost estimates. The cost estimate's date and percentage of the actual cost are shown opposite each project listed. The ratio of estimated cost to actual cost is dependent on the point in the project at which the estimate was made. For example, the estimate for Surveyor was made at the pre-Phase A level, while that quoted for Mariner '69 was a Phase A/Phase B estimate. Project costs are obviously difficult to estimate at the pre-Phase A level, and have been underestimated by as much as 4 to 1. This is due in part to the uncertainty coupled with changes in project length and varying project specifications increase the difficulties in making a reliable cost estimate at any project level. While it is not expected that the SAI analysis will completely solve this problem (hindsight will always be easier than foresight), it was the objective of this study effort to improve on the dismal accuracies of pre-Phase A cost estimates.

PAST PERFORMANCE OF COST ESTIMATION

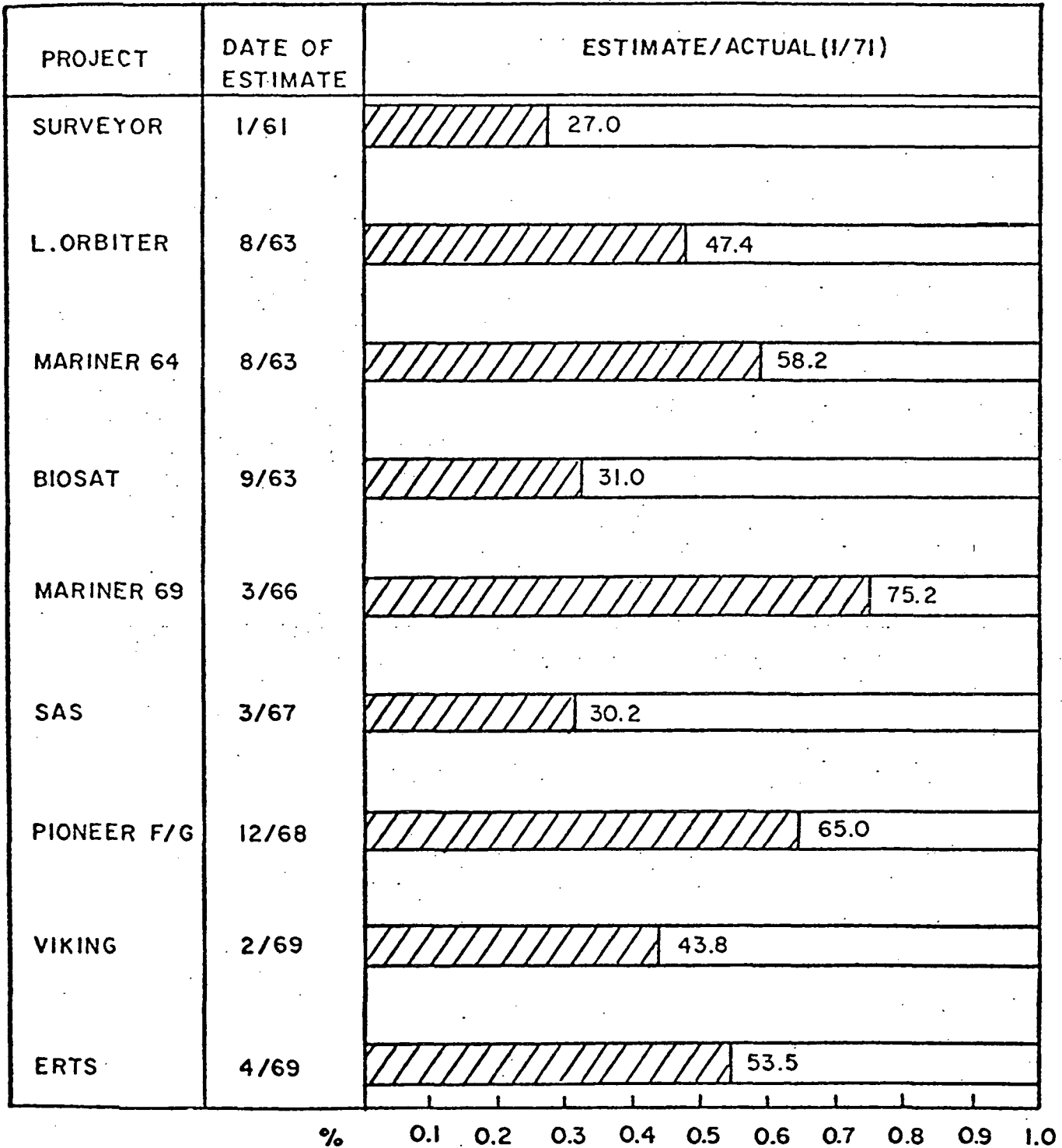

ESTIMATE DIVIDED BY ACTUAL



TOTAL PROGRAM

Study Plan

The plan of analysis for this study is outlined by the flow diagram below and proceeds in a sequential order. First, a framework of specific objectives and individual steps of analysis were established. A key result of this first effort was the selection of specific past and current projects for the data analysis. With regard to data collection, it was determined that manpower (as per basic study premise) charged directly to all project contracts would have to be assimilated as well as dollar costs. Data collection was accomplished by contacting NASA Headquarters, NASA Research Centers, and Prime Contractors. Analysis of collected data has also been completed. Raw data have been divided into S/C categories (e.g., program management, science, spacecraft subsystems, etc.) and these categories subsequently broken up into standard financial subdivisions (e.g., direct labor hours and dollars, overhead, material, and ancillary support). An analysis of these data comparing direct labor hours and dollars has confirmed the authenticity of labor hours for the modeling analysis. Note that a feed-back loop to model definition is shown to indicate that our source of model improvement will come from testing and using the model itself. Another source, shown by the dotted square is continued data collection to improve the data base on which many elements of the overall procedure are being founded.

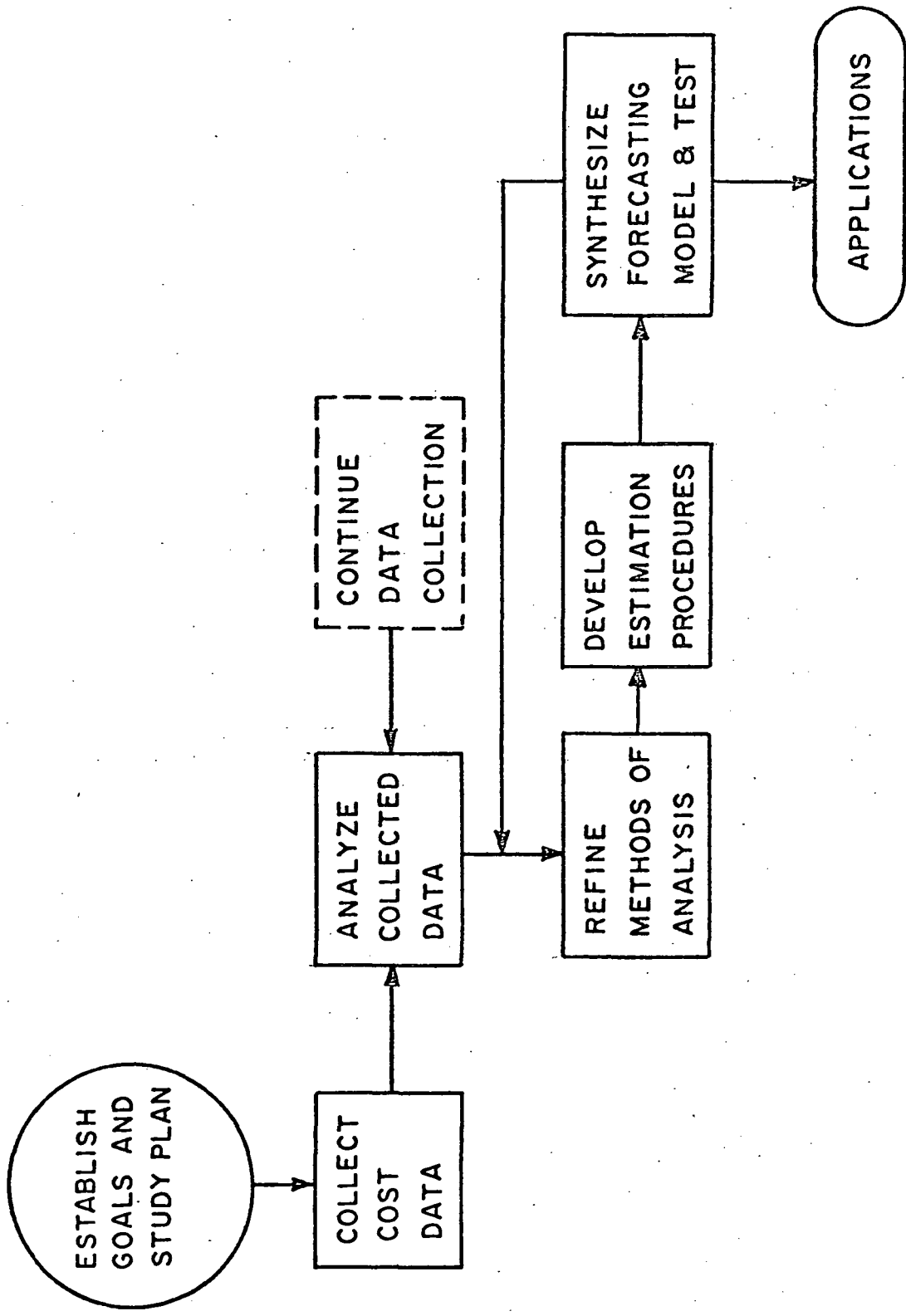

COST STUDY PLAN

Data Acquisition and Analysis

At the very outset of this study it was obvious that historical data would play an important role in the analysis. It was also recognized that the amount of data was quite limited if restricted to unmanned lunar and planetary projects. The eight programs selected for data review are shown on the facing page along with their review status. Note that the Ranger series and Mariner Venus '62 and '67 have not been included. These projects were judged atypical for various programmatic reasons including insufficient data, very early development (i. e., almost no technology base), and parasitic development. It was recognized early in the data collection process that NASA Headquarters and Centers did not have the financial details of program costs that were required for our analysis. Initial contacts were made with prime contractors through NASA Centers, and with the prime contractors' and their subcontractors' support the analysis was begun. The cost data supplied was in a form that permitted analysis below the subsystem level and allowed for the adjustment of subsystem definitions to insure compatibility among projects. For example, in addition to subcontracts, TRW supplied 1496 S/C categories on a "level 7" breakdown for Pioneer F/G, while JPL supplied 4000 cost sheets for Mariner-69. A detail breakdown of data received and analyzed is illustrated on the opposite table.

Data Acquisition and Analysis

	Visit		Data Received		
	NASA	Contractor	S/C Categ.	Finan. Categ.	Subcontracts
Mariner '64	X	JPL	246	79	48
Surveyor	X	Hughes	1008	43	54
Lunar Orbiter	X	Boeing	294	81	5
Mariner '69	X	JPL	328	89	55
Mariner '71	X	JPL	348	109	86
Pioneer F/G	X	TRW	1496	59	21
Viking Lander	X	Martin	301	59	25
Viking Orbiter	X	JPL	822	129	25
			-----	-----	-----
Total			4843	648	319
			-----	-----	-----
Avg. per Program			605	81	40

Financial Data Analysis

This diagram shows schematically the process of data analysis used in the early phase. Note that each data point is in fact three dimensional, relating spacecraft, and financial categories for each of the prime and sub-contractors. Over 10 million original data cubes were reduced to some 624 data cubes. It has been demonstrated in the analysis that the final matrix achieved with this high resolution is considerably different than what would be obtained by listing coarse project data directly. The accuracy and consistency of the estimating relationships presented later in the report are directly attributed to the much improved cost visibility gained by this data reduction process.

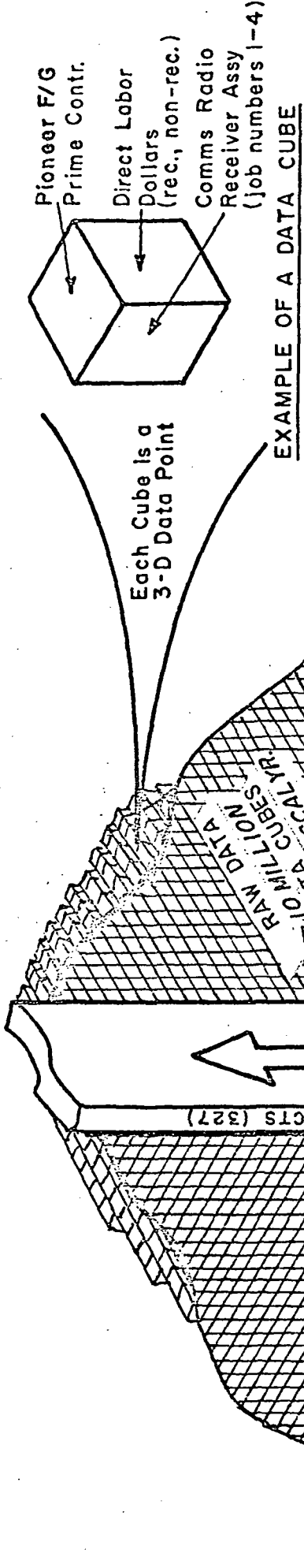

Each Cube is a 3-D Data Point

PHASE I

PHASE II

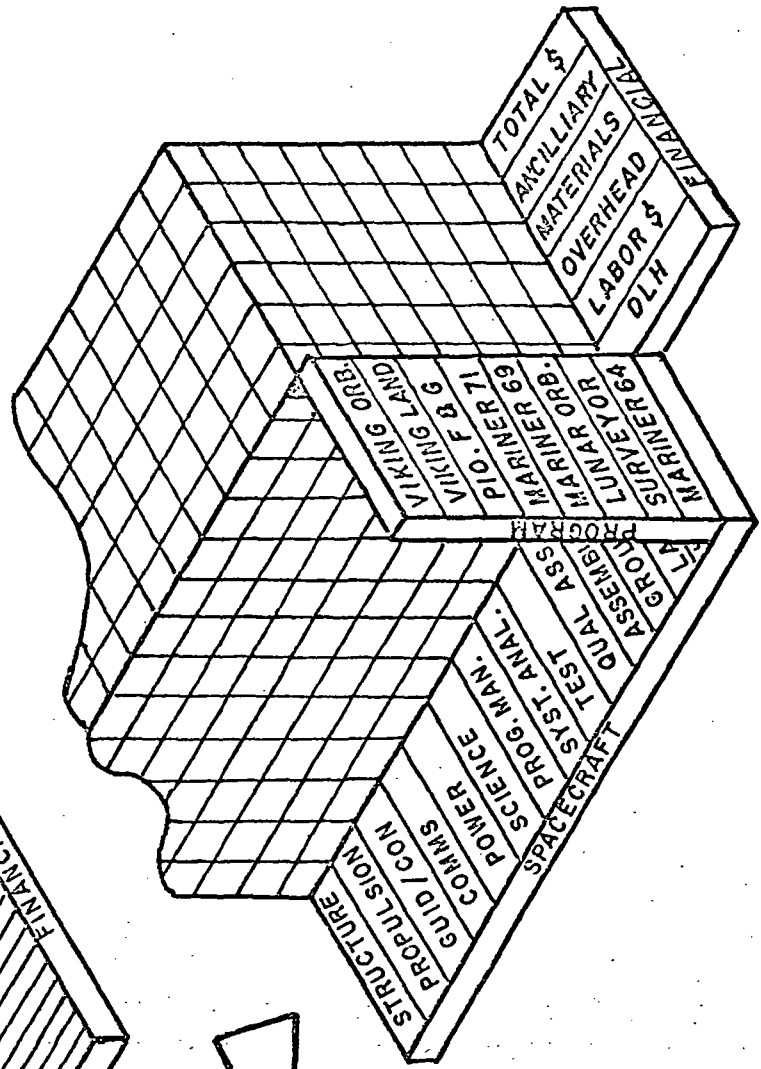

FINANCIAL DATA ANALYSIS

Financial Format for Data Analysis

The cost data and direct labor manhours of each project analyzed have been summarized in a financial work breakdown sheet, the format of which is illustrated below. The list of normalized S/C categories found to be applicable to all projects is given down the left-hand side of this form. The total cost of each of these categories is further broken down into financial subdivisions, shown across the page. Note that the first column contains the direct labor manhours for each category. Also, the prime contractor's fee, which is easily computed, is not included as a subdivision, or in the totals. The fees listed are subcontractor's only. Totals are given at the bottom of this form. A detailed breakdown of definitions for the financial and technical subdivisions follows on the next several pages.

Financial Format

<u>Major Element</u>	<u>Manhours (000)</u>	<u>Labor</u>	<u>Overhead</u>	<u>Material</u>	<u>Ancillary Costs</u>	<u>Fee</u>	<u>Total</u>
Program Management							
Systems Analysis/Sys. Eng.							
Test							
Quality Assurance & Reliability							
Assembly & Integration							
Ground Equipment							
Launch/Flight Ops							
Data Analysis							
Subtotal							
Structure							
Propulsion							
Guidance & Control							
Communication							
Power							
Science Instruments							
Miscellaneous							
Subtotal							
Total							

Financial Categories

Direct Labor

"Direct Labor Hours" refers to the number of labor hours charged directly to contract projects for engineers, scientists, technicians, administrative and manufacturing personnel, and office and clerical workers. Cross charging (short term loans of personnel from another area) is not included.

"Direct Labor Dollars" refers to the salaries and wages charged directly to contract projects. There is a high correlation between direct labor hours and direct labor dollars through the wage rate.

Financial Categories

General Description

Direct Labor Hours Breakdown

Science and Engineering
Administrative (Not Overhead)
Office and Clerical (Not Overhead)
Technical
Manufacturing and Other

Direct Labor Dollars Breakdown

Engineer and Scientist Salaries
Administrative Salaries (Not Overhead)
Office and Clerical Wages (Not Overhead)
Technical
Manufacturing and Other Wages

Financial Categories

Overhead

Overhead or burden may be broken down into four categories; General Burden, Rental Services, Communication and Utilities, and Administrative Services. The General Burden and Administrative Services comprise a large fraction of the total overhead. The notion here was to uniformly define overhead across the industry so that meaningful analysis could be done. As a consequence the general definition of overhead as used by private industry was applied across all eight programs.

Financial Categories

Overhead (Burden)

General Burden

Project Staff Burden
Technical Division Burden
Administrative Burden (Not Direct Labor)
Laboratory Burden

Rental Services

Rental of Equipment
Rental of Space
Special Telephone Services

Communication and Utilities

Telephone and Telegraph Service Charges
Toll and Message Charges
Other Charges

Administrative Services

Multilith
Graphics
Periodicals
Photography
Publications
Graphics
Administrative Computer Services

Financial Categories

Material

"Direct Material Cost" is generally defined to be the total cost of purchased parts, raw materials, purchased fabrication, and subcontracted assemblies charged directly to contract projects. If purchased parts' or subcontracted assemblies' costs charged to the contract were minor, they were treated as direct material costs.

Ancillary Support

"Ancillary Support" is a miscellaneous category for items which cannot practically, within the limits of this study, be identified with direct labor, overhead or material costs. Where the project contractor's accounting procedures allow, the amounts for ancillary support are stated for each financial subdivision.

Financial Categories

Material (ODC)

Material Purchases
Material Transfers
Minor Piece Parts
Freight
In House Material
Miscellaneous
Equipment-movable
Equipment-installed
Equipment-minor
Hand Tools
Special Tooling
Special Test Equipment

Ancillary Support

Instrument-Repair-Calibration
Eastern Test Range
Environmental Lab.
Space Simulator
Computer Programming Section
Computer Digital Operations
Contract Inventory
Chemistry Laboratory
Other Miscellaneous

Spacecraft Categories

Technical Support

The costs incurred in the spacecraft categories are spread over all financial categories and vice versa.

Program Management

This category covers all the directly charged management, liaison and document control in the course of the project. Additional management services, provided out of the overhead are not included here.

Systems Analysis and Engineering

This category covers the design and analysis which leads to the final configuration of the spacecraft and its mission. Theoretical systems analysis, such as stress calculations are included here.

Test Program

The test program is that which is applied by the prime contractor to completed, delivered, subsystems and to the total spacecraft. It does not include tests as part of the subsystem assembly phase nor does it include launch operational tests.

Quality Assurance and Reliability

This includes all the activities related to ensuring the reliability of the final spacecraft system. It includes parts selection, some special design considerations and specific tests on components.

Spacecraft Categories

Technical Support

Project Management

Project Staff
Division Reps
Project Control
Documentation
Project Scientist
Data Management

System Analysis and Engineering

Pre-Flight Miss. Anal.
Trajectory Design
Material, Electronic Parts
System Engineering
Stress and Dynamics
System Integration

Test Program

Environmental Test (Induced and Natural)
Simulation
Subsystem Test (Prime Only)
Torsional Test
Eng. Model Test
Test Planning Procedures

Quality Assurance and Reliability

Reliability
Quality Assurance
Electronics
Safety
Sterilization

Spacecraft Categories

Technical Support (cont'd.)

Assembly and Integration

This includes the facilities, services and personnel associated with the final assembly of the spacecraft and its payload. Normally this takes place under clean room conditions.

Ground Equipment

This is all the electronic and other equipment, purchased by the project for the final test and operational phases of the project. Equipment bought under previous projects is often made available free of charge except for the normal maintenance costs.

Launch and Flight Operations

This category is the sum of the launch costs, the mission operations costs during transit and the encounter costs. It includes the project engineering and control room costs.

Data Analysis

This includes all of the post encounter and data processing costs. Data handling on the spacecraft and on the ground, however, are not considered part of the data analysis.

Spacecraft Categories

Technical Support (cont'd.)

Assembly and Integration

Vehicle Design and Integration (Ass'y and Integ. Portion Only)

Flight Spacecraft Installation and Assembly

Systems Integration

Spacecraft Integration

Payload System Integration

Ground Equipment

Subsystem Operation

Ground Instruments

Ground Telemetry Subsystems

Ground Support Equipment

SFO Support Equipment

Ground Equipment Analysis and Test

Launch and Flight Operations

Mission Ops.

Flight Path Analysis

Data Analysis

Extended Mission

ETR Ops.

Science Teams (Post Launch)

Data Analysis

Data Processing Team

Telecommunications Flight Analysis

Science Data Team Support

TV Image Processing

Spacecraft Categories

Subsystems

Structure

The structure subsystem includes the points of the spacecraft not specifically included in the individual subsystems. It includes the main spacecraft members, landing gear, thermal control, etc. Mechanisms, pyrotechnic devices and cable harnesses are lumped in with the structure category.

Propulsion

The propulsion system includes all impulsive or low thrust propulsion systems, fuel and tankage use after injection from earth orbit. This includes orbital retro-systems and lunar descent propulsion. Where a propulsive maneuver is replaced by an aerodynamic maneuver as for Mars entry, the aeroshell is categorized as propulsion.

Guidance and Control

This includes all functions of sensing positional errors, onboard computation of corrections and the application of correction functions for trajectory guidance and attitude control. Also included are the spacecraft intelligence as CC&S and the articulation of science platforms.

Spacecraft Categories

Subsystems

Structure

Mechanical System

Structure and Dynamics

Pyrotechnics

Flight Cabling

Flight Connectors and Wire

Scan Control

Thermal

Propulsion

Propulsion Subsystem

Retro Engine

Vernier Propulsion

Propulsion Analysis and Support

Hardware Control

Guidance and Control

G & C System and Design

CC&S

Attitude Control

Celestial Sensor

Articulation Control

Gas Lab Support

Spacecraft Categories

Subsystems (cont.)

Communications

This includes the components and functions involved in the handling of data from the experiment, the storage, massaging and eventual transmission of the data to Earth. It also includes the reception of command signals from Earth and the systems used for data relay from associated probes or landers.

Power

This category is made up of all sources and systems for the generation, conditioning and switching of the spacecraft power supply. The special case of RTGs (Radio Thermionic Generators) although part of this category are not included in the model.

Science Instruments

This includes the complete experimental payload with the initial interface for the data. Individual instruments and the scientists involved in the pre launch experiment design and definition are included.

Spacecraft Categories

Subsystems (cont.)

Communications

Telemetry Subsystem
Telemetry Comm. Analysis
Radio and Command
Data Storage
Data System
Flight Data Subsystem
System Ops.
Relay Subsystem

Power

R. T. G. 's
Batteries
Power Conditioning/Panel
Boost Regulator
Central Power Control
Solar Array

Science

T.V. Electronics
T.V. Optics
Photo Science
S-Band Occultation
Science Instruments
Science Teams (Pre Launch)

Average Percent Comparison of

Dollars and Labor Hours for all Major Projects

The table illustrates the relationship of manhours to cost as average across all major projects. For example, guidance and control represents 9.2% of the total cost and requires 9.1% of the total manhours. The small deviation between the percentage of manhour effort and percentages of cost for each S/C category is evident. It appears from this breakdown that manhours can be used as a measure of the effort required by a project and can then be readily translated to dollars.

All Major Projects (Avg.)

Percent Comparison of Dollars* and Labor Hours

<u>Major Elements</u>	Percentage Distribution	
	<u>Cost</u>	<u>Man Hours</u>
Program Management	5.3%	5.4%
Systems Analysis/Sys. Eng.	4.0	4.3
Test	7.0	7.2
Quality Assurance & Reliability	4.7	5.3
Assembly & Integration	2.8	2.8
Ground Equipment	9.0	8.1
Launch/Flight Ops.	10.0	10.0
	<hr/>	<hr/>
Subtotal	42.8%	43.1%
	<hr/>	<hr/>
Structure	8.9	9.0
Propulsion	5.2	4.5
Guidance & Control	9.2	9.1
Communication	13.9	14.7
Power	4.1	4.7
Science	15.2	14.0
Miscellaneous	0.7	0.9
	<hr/>	<hr/>
Subtotal	57.2%	56.9%
	<hr/>	<hr/>
Total	100.0%	100.0%
	<hr/> <hr/>	<hr/> <hr/>

*w/o fee

Project Comparisons of Direct Labor Costs

Shown below are the direct labor costs (as percents of total costs) for the eight reviewed projects. The average value is 29.6% with the maximum deviation being only 2.8%. This excellent correlation is even more impressive in light of the large variation of total efforts across these projects. Hence, it is concluded that if the direct labor cost can be determined the total project cost can be easily approximated by dividing by 29.6%. Since manhours are easily identified with direct labor cost, man-hours have been selected as the major forecasting unit.

DIRECT LABOR DOLLARS AS PERCENT OF PROJECT

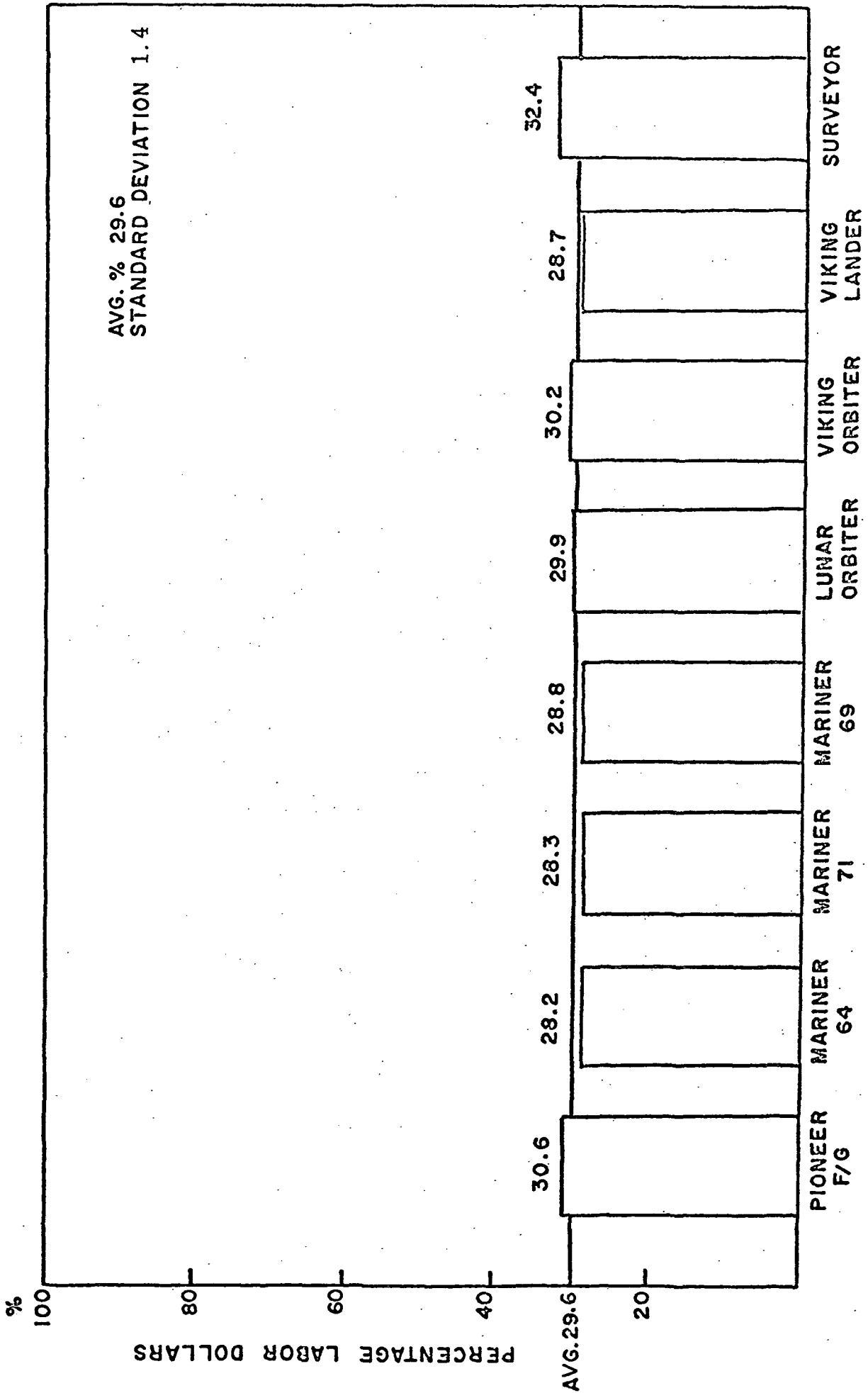

Manpower Advantages

Forecasting manhours has several distinct advantages over forecasting total project dollars. Among these are separation of estimates from inflation and an ease in costing low volume production. Two projects separated in time are only comparable on a cost basis if some inflationary factor is applied to the older project. Such inflationary factors are difficult to formulate for total project costs and often fail to accurately represent the actual financial conditions within the industry. The space industry has not yet been able to use mass production techniques and thus the total cost of each completed item is not substantially decreased through additional production. Hence, the cost of a project's hardware is directly connected to the manhours involved in development, fabrication, and testing. This may change with the Shuttle era, and manpower analysis during this period will highlight how cost has been affected since manpower is a homogeneous and standard unit across all projects. Also, the manhour approach provides management with a tool to evaluate the cost and complexity of a new project in light of previous manpower-complexity relationships.

MANPOWER MODELING BENEFITS

- MANPOWER IS A CONSISTENT COST ELEMENT ACROSS ALL PROGRAMS
- THE PRESENT AVERAGE MANPOWER RATIO OF 29.6% MAY CHANGE IN THE SHUTTLE ERA WITH THE REDISTRIBUTION OF MAJOR COST BETWEEN MANPOWER AND MATERIALS.
- MANPOWER PROVIDES MANAGEMENT WITH MORE INSIGHT IN ANALYZING ESTIMATED AND ON-GOING PROJECTS, SINCE IT IS THE LOWEST COMMON DENOMINATOR IN THE GOVERNMENT ACCOUNTING SYSTEM.
- THE EFFECT OF LEARNING AND INHERITANCE CAN BE ANALYZED AND MEASURED BETTER IN TERMS OF MANPOWER. SIMILARLY INFLATION AND THE MODE OF CENTER/PRIME CONTRACTOR CONTROL CAN BE MORE READILY INCORPORATED.

Non-Recurring and Recurring Subsystem Illustration

The chart on the facing page illustrates that Non-Recurring Direct Labor Hours (NRDLH) were identified and modeled in accordance with the financial/manpower categories. Yearly manpower records were examined and compiled up to the proof test model and modeled with good results. The manpower for each flight article was then evenly separated in regards to each project. The results and range of this analysis are presented on the next chart. This seems reasonable since the space industry has not yet been able to use mass production techniques and thus total manpower of each completed item is not substantially decreased through additional production. Hence, a model was created for NRDLH with a straight percentage applied to this for flight articles.

MAN HOUR ANALYSIS.
FISCAL YEARS JUNE TO JUNE

PRIME CONTRACTOR
SUBSYSTEM A
(3 FLIGHT ARTICLES)

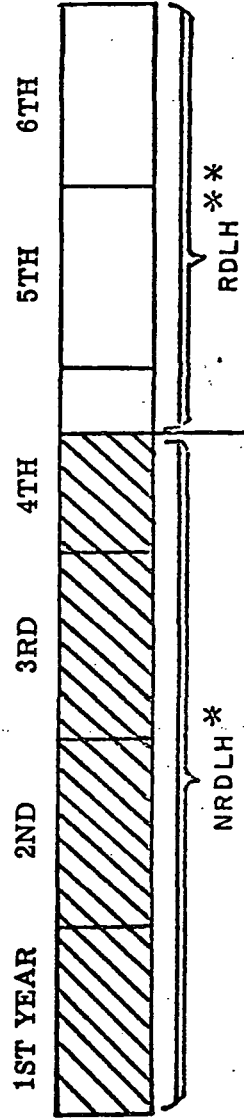

SUBCONTRACTOR
SUBSYSTEM A
(3 FLIGHT ARTICLES)

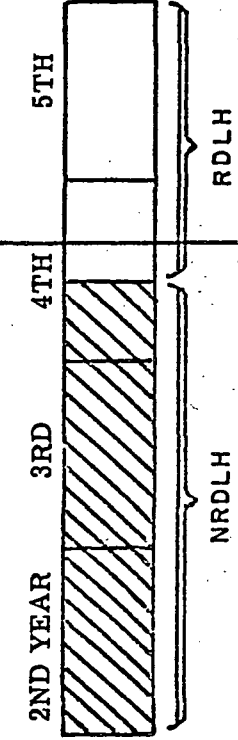

TOTAL EFFORT
SUBSYSTEM A

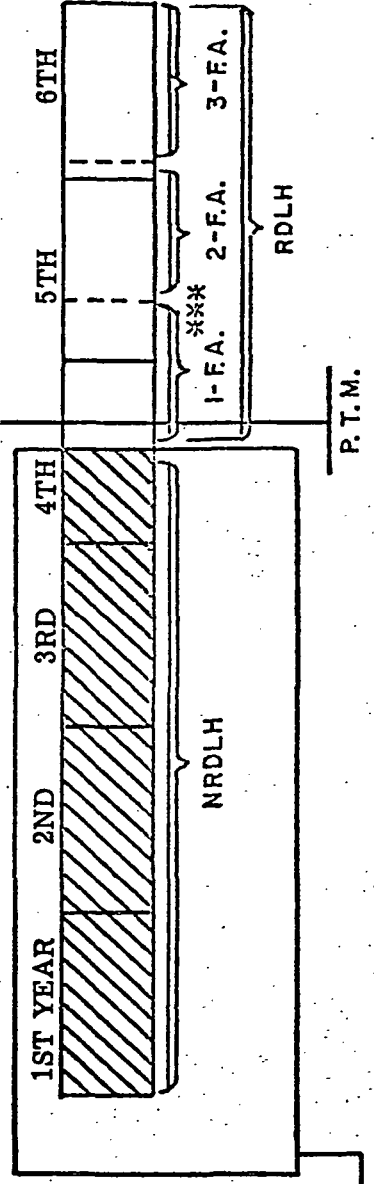

$$\text{SUBSYSTEM A} = [1 + B \text{ F.A.}] (\text{NRDLH})$$

MANHOURS

* NRDLH = NON-RECURRING DIRECT LABOR HOURS
** RDLH = RECURRING DIRECT LABOR HOURS
*** F.A. = FLIGHT ARTICLE

WHERE B = $\frac{\text{AVG. F.A. MANHOURS}}{\text{TOTAL NON-RECURRING MANHOURS}}$

INPUTS TO MODELING PHASE

- FOR EACH PROJECT A FINANCIAL AND SPACECRAFT CATEGORIZATION WITH EXTENSIVE VISIBILITY
- LABOR AS PERCENT OF EACH MAJOR ELEMENT AND TOTAL
- INFLATION MODEL FOR EACH MAJOR ELEMENT AND TOTAL
- NON-RECURRING AND RECURRING BREAKOUT FOR SPACECRAFT SUBSYSTEM CATEGORIES

SECTION 2

**MANPOWER/COST
MODELLING**

Page Intentionally Left Blank

INTRODUCTION TO COST MODEL DEVELOPMENT

● Applications and Objectives

Forecast cost of future automated planetary/lunar missions at time of (pre) Phase A definition.

Average estimation error within 10% for projects included in model data base.

Estimation error within 20% for forecasting future mission costs.

● Requirements

Input parameters must be consistent with (pre) Phase A definition, e.g., weight, power, event times, etc.

Functional form of LER's should be simple algebraic expressions, e.g., linear, power law, exponential.

Number of coefficients in a given LER should be limited to improve statistical significance of data fit.

LER based on unbiased model (\sim zero mean error).

● Premises

A cost model does not represent "truth" but only a simplified, empirical approximation to actual cause and effect.

Due to the phenomena of averaging, total project cost will be more accurately estimated than individual elements (from a statistical standpoint of percentage error).

Reduction of variance of fit in individual elements will further reduce error variance in total cost.

COST MODEL OUTLINE

On the following page is a flow diagram of the key elements of the cost model. The Labor Estimating Relationships provide the basic forecasting procedure. This step is supplied with mission dependent information, and with scaling laws, physical and mathematical relationships, and synthesis guidelines, provide the basic estimate of man-hours. The remainder of the model deals with converting the basic cost element, direct labor man-hours, into cost. This requires three additional steps. First, the direct labor man-hours must be adjusted for inheritance. The average pay scale (\$/hr.) must be determined for the period of the project. If desired the selected pay scale could include inflation between the time of the estimate and project execution. The final step involves converting direct labor cost into total project cost. It has been found, with a high degree of consistency, that direct labor cost of unmanned lunar/planetary projects comprises 30% of total project cost.

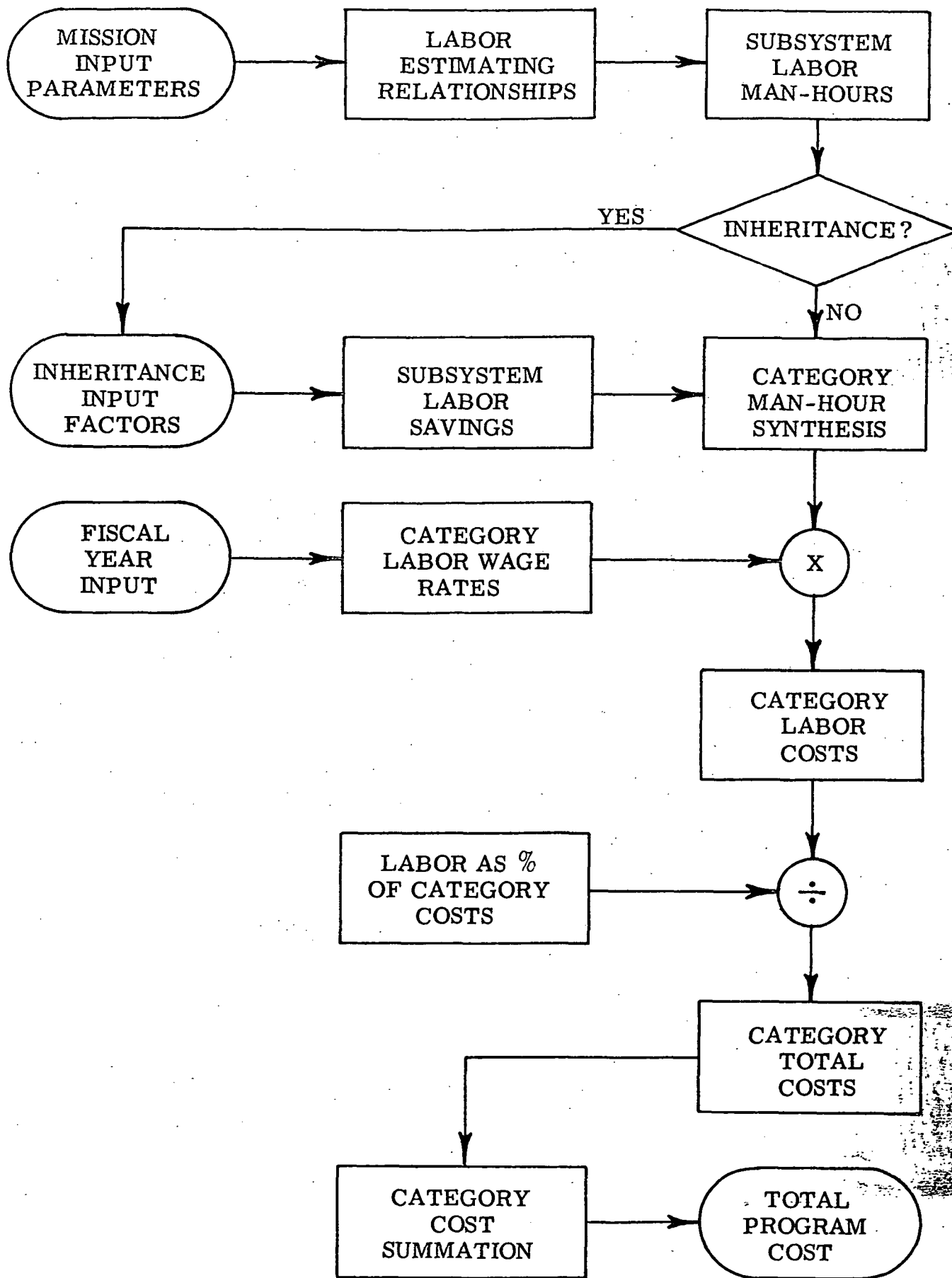
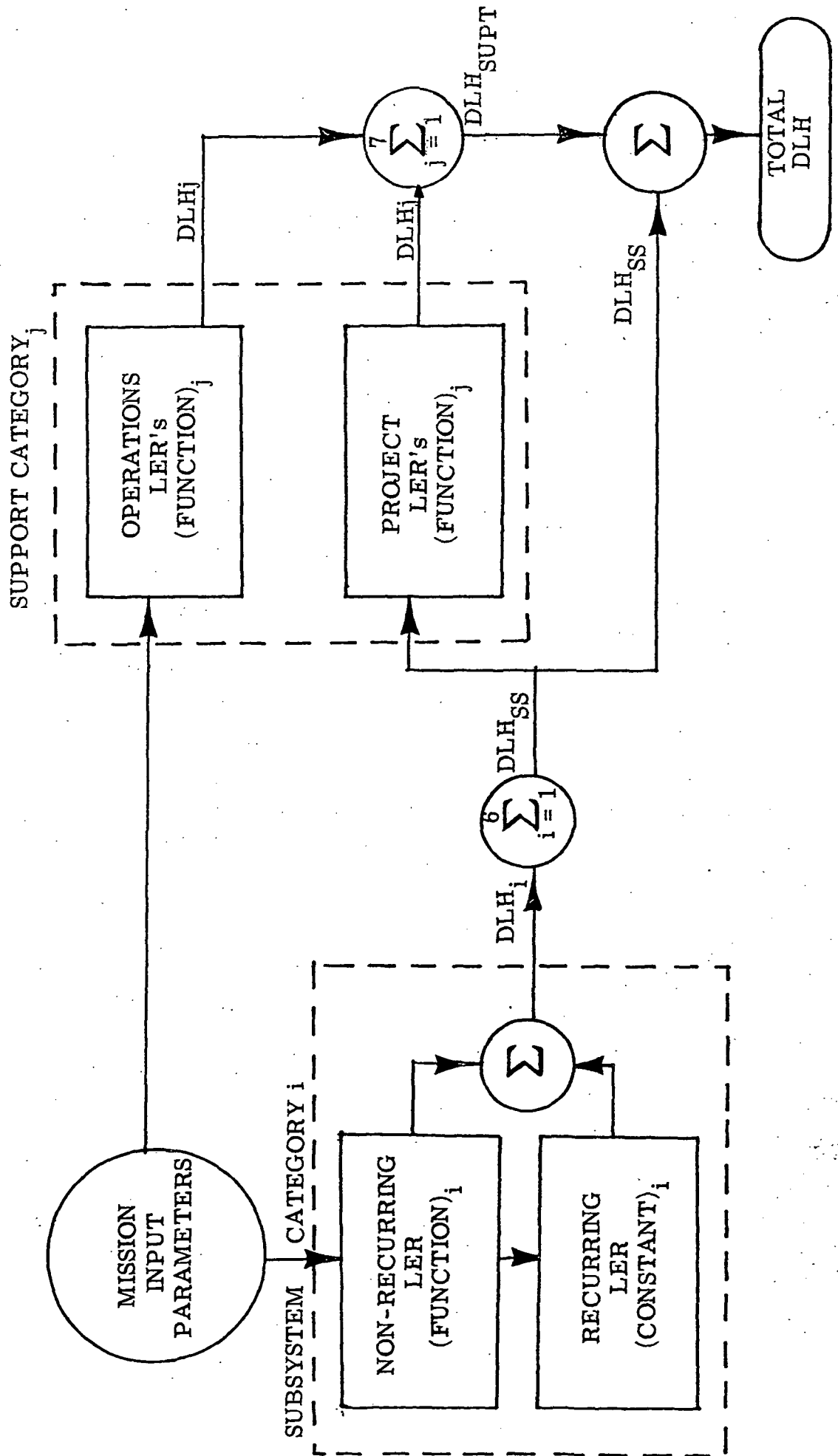

FIGURE 1. PLANETARY COST MODEL SCHEMATIC

Modeling Approach

The overall modeling procedure adopted is described by the schematic flow diagram below. Beginning with spacecraft/mission descriptive parameters (principally weight, power and dates), labor estimating relationships are developed by least-squares data fitting for each of the 6 subsystem categories. Non-recurring direct labor in each category is modeled as an appropriate function of the input parameters while the recurring direct labor is taken to be proportional to the number of flight articles and the average recurring/non-recurring ratio in that category. The project LER's in the support category are modeled as a function of the total subsystem direct labor hours (DLHss). The operations LER's in the support category are modeled as a function of mission dependent parameters. Again, a least-squares data fitting procedure is employed for the support categories. It should be noted that the diagram as drawn more clearly represents the estimation rather than the modeling procedure. For modeling purposes, the coefficients of the project support category LER's are determined by least-squares fitting of the actual values of DLHss comprising the 8-project data base rather than the estimated values.

MODELING APPROACH FOR DIRECT LABOR HOURS



Inputs for SAI Labor and Cost Estimation Model

Z\$ Date of First Launch (Month & Calendar Yr. e.g., 11/1975)
D2 Fiscal Wage Date (Fiscal Yr. e.g., 1975.9)
N1 Number of Flight Articles
W1 Weight of Power Subsystem Excluding RTG's (lbs.)
N2 Number of RTG Units per Spacecraft
L1 RTG Fuel Loading (Thermal Watts)
S1 Total Weight of Structure Subsystem (lbs.)
S2 Weight of Mechanisms and Landing Gear (lbs.)
S3 Weight of Thermal Control, Pyro. and Cabling (lbs.)
P1 Propulsion System Dry Weight Excluding Throtttable
Liquid Vernier for Landers (lbs.)
P2 Liquid Vernier Dry Weight (lbs.)
P3 Aerodeceleration Subsystem Weight (lbs.)
G1 Total Weight of Guidance/Control Subsystem (lbs.)
G2 Weight of Radar in G/C Subsystem (lbs.)
C1 Weight of Radio Frequency Comm. Subsystem (lbs.)
C2 Weight of Data Handling Subsystem (lbs.)
C3 Weight of Antennas (lbs.)
Q1 Total Weight of Science Experiments (lbs.)
Q2 Weight of Lander Surface Experiments in Q1
Having Significant Sampling/Processing Operations (lbs.)
Q3 Pixels per Line of TV (or Equivalent Visual Imaging)
K1 Total Mission Duration From First Launch to End of Last Mission
Minus Time When No Spacecraft is in Flight (mo)
K2 Total Encounter Time of the Prime Mission (mo)
K3 Total Number of Encounter Phase Start Ups
K4 Total Number of Science Teams During Encounter Phase

Spacecraft and Mission Parameters

	<u>M64</u>	<u>M69</u>	<u>M71</u>	<u>PIO</u>	<u>VO</u>	<u>LO</u>	<u>VL</u>	<u>SUR</u>
Z\$	11/64	2/69	5/71	2/72	9/75	7/66	9/75	5/66
D2	1964.5	1968.4	1970.9	1971.6	1974.0	1966.2	1973.4	1965.8
N1	2	2	2	2	2	5	2	7
W1 (lbs.)	150	174	165	39	293	91	190	90
N2	-	-	-	4	-	-	2	-
L1 (Th. watts)	-	-	-	650	-	-	675	-
S1 (lbs.)	159	261	477	156	770	137	695	258
S2 (lbs.)	10	53	55	31	75	23	51	83
S3 (lbs.)	73	96	115	57	167	42	230	73
P1 (lbs.)	27	25	216	24	391	63	-	147
P2 (lbs.)	-	-	-	-	-	-	176	77
P3 (lbs.)	-	-	-	-	-	-	473	-
G1 (lbs.)	75	83	88	13	158	73	171	90
G2 (lbs.)	-	-	-	-	-	-	71	45
C1 (lbs.)	35	54	48	23	108	36	56	28
C2 (lbs.)	61	80	70	12	107	13	58	24
C3 (lbs.)	7	9	9	46	15	12	19	10
Q1 (lbs.)	41	130	150	66	152	144	200	88
Q2 (lbs.)	-	-	-	-	-	-	119	21
Q3	200	945	832	462	1182	5634	515	1000
K1 (mo.)	10	5	16.7	42.6	16.3	29.0	14.1	7.0
K2 (mo.)	2.5	0.3	3.0	3.7	6	2.5	3	2.3
K3	1	1	1	2	1	5	1	10
K4	5	6	5	3	4	1	10	3

Model for Structure Subsystem

The LER's for the non-recurring and recurring labor hours of the structure subsystem are, respectively:

$$\text{Non-landers: } NR_{ST} = 6.68(S2)^{0.691} + 11.9(S3)^{0.507} + 28.4(S1-S2-S3)^{0.427}$$

$$\text{Landers: } NR_{ST} = 1.35(S2)^{1.35} + 11.9(S3)^{0.507} + 28.4(S1-S2-S3)^{0.427}$$

$$R_{ST} = 0.109(N1)(NR_{ST})$$

S1 is the total weight of the structure subsystem
 S2 is the weight of the mechanisms and landing gear
 S3 is the combined weight of the thermal control, pyrotechnic and electrical cabling components
 N1 is the number of flight articles

The total structure includes the bioshield (if any), but not the aerodeceleration components (aero-shell, decelerator, parachute). For atmospheric entry applications, the later components are included as a functional part of the propulsion subsystem.

The inflated labor dollar rate is:

$$\text{\$ per hour rate} = 4.65(1.052)^{(D2-1964.5)}$$

D2 is the fiscal wage date

The Structure Subsystem cost is 31% labor. The limits on the input parameters used in our model are:

<u>Parameter</u>	<u>Min.</u>	<u>Max.</u>
S1	137 lb.	770 lb.
S2	10 lb.	83 lb.
S3	42 lb.	230 lb.
N1	2	7

Structure is the most difficult and poorly modeled subsystem. The model is essentially unbiased (near zero mean error) but the mean absolute error of the 8 projects is 33%. The best data fit in the above non-recurring LER was found to be the second term, i. e., thermal control, pyro and cabling.

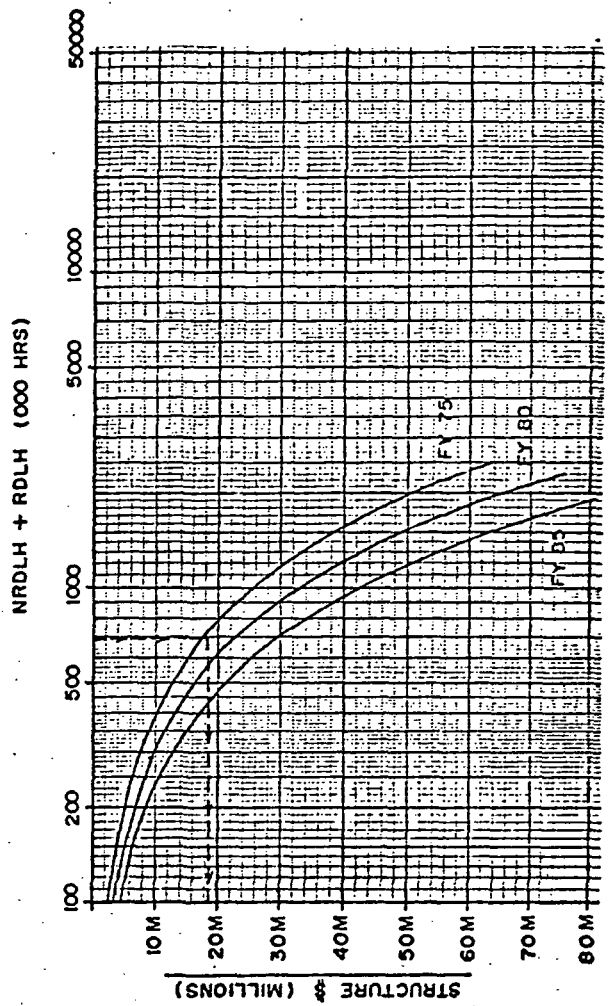
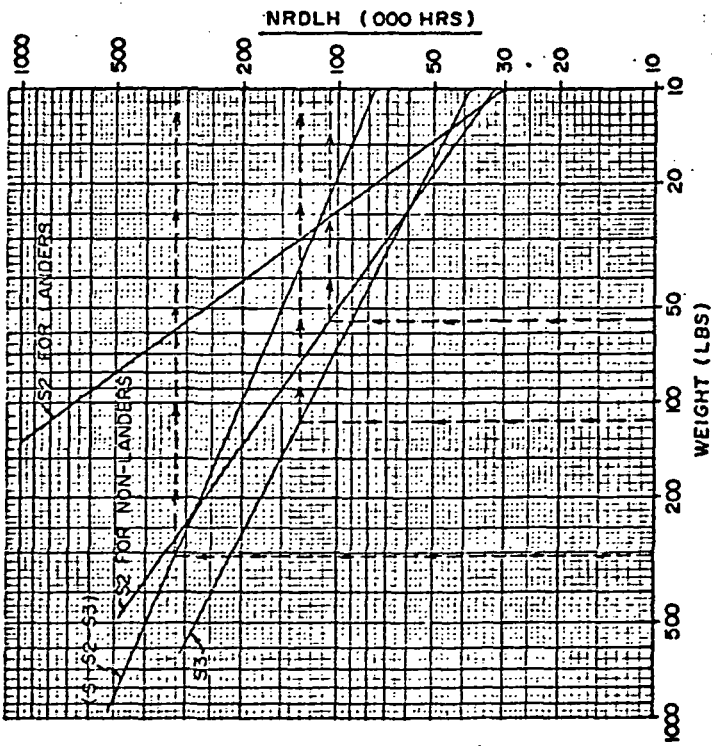
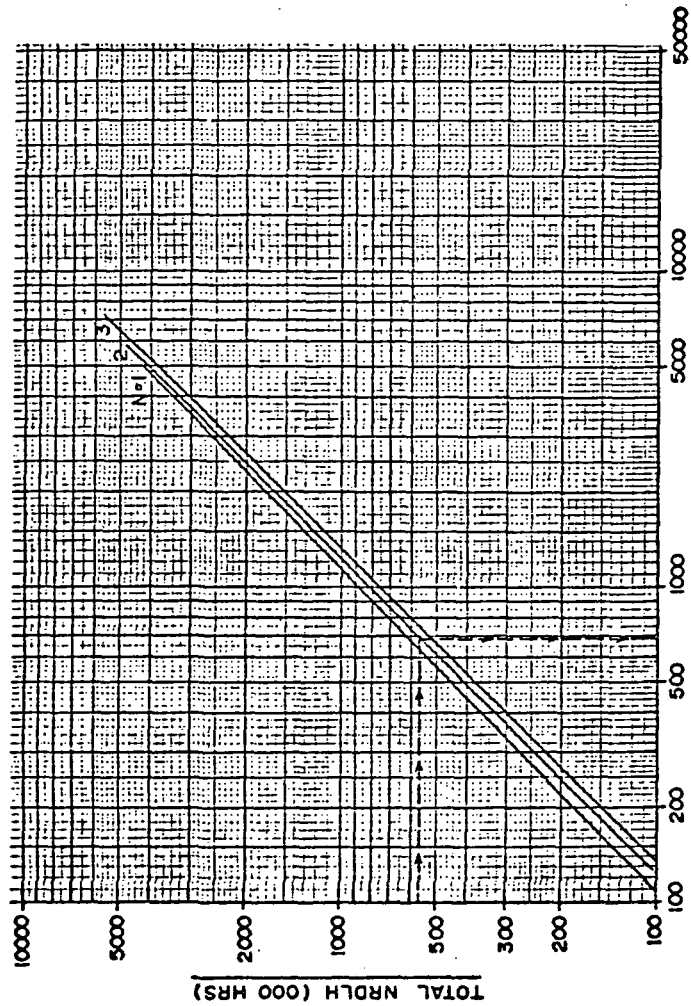

EXAMPLE: MARINER MARS 71
 2 FLIGHT ARTICLES
 S1-S2-S3 = 507 NRDLH S1-S2-S3 = 327.6
 S2 = 55 NRDLH S2 = 106.5
 S3 = 115 NRDLH S3 = 131.9
 TOTAL NRDLH = 566
 NRDLH + RDLH = 689.0
 STRUCTURE \$ = 18.6 MILLION IN FY 75 \$

STRUCTURE COST ESTIMATION

Model for Propulsion Subsystem

The LER's for the non-recurring and recurring labor hours of the structure subsystem are respectively:

Non-Probe: $NR_P = 21.6(P1)^{0.5} + 34.1(P2)^{0.5} + 14.4(P3)^{0.5}$

Probe: $NR_P = 21.6(P1)^{0.5} + 34.1(P2)^{0.5} + 11.3(P3)^{0.5}$

$R_P = 0.148(N1)(NR_P)$

P1 is the dry weight (lbs) of the "usual" propulsion system associated with midcourse ΔV correction and orbit insertion

P2 is the dry weight of the liquid, throttlable system for terminal control of landers

P3 is the weight of the aerodecelerator system including aeroshell and decelerator structure and parachutes

N1 is the number of flight articles

The inflated labor dollar rate is:

$\$ \text{ per hour rate} = 4.86(1.043)^{(D2-1964.5)}$

The Propulsion Subsystem cost is 26.9% labor. The limits on the input parameters used in our model are:

<u>Parameter</u>	<u>Min.</u>	<u>Max.</u>
P1	24 lbs.	391 lbs.
P2	77 lbs.	176 lbs.
P3	473 lbs.	473 lbs.

The one large percentage error is for the Mariner 64 project, although the absolute error for Mariner 64 is not the largest among the 8 projects. This causes the apparent percentage bias toward overestimation indicated by the mean error of 10.6%. If Mariner 64 were omitted from the statistical error measure, the mean absolute errors would be, respectively, -2.0% and 12.7%.

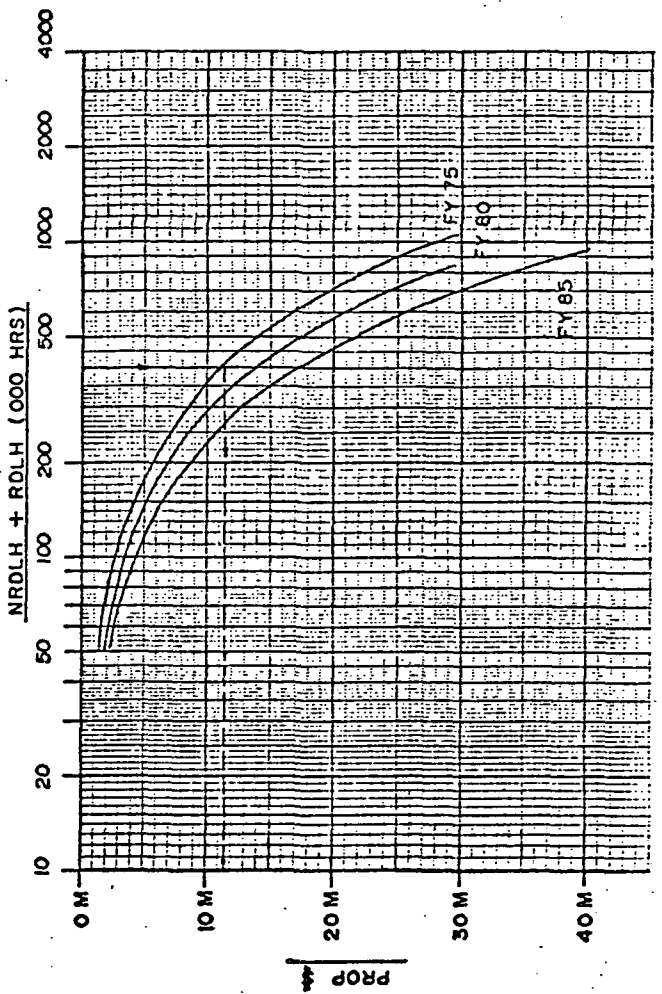
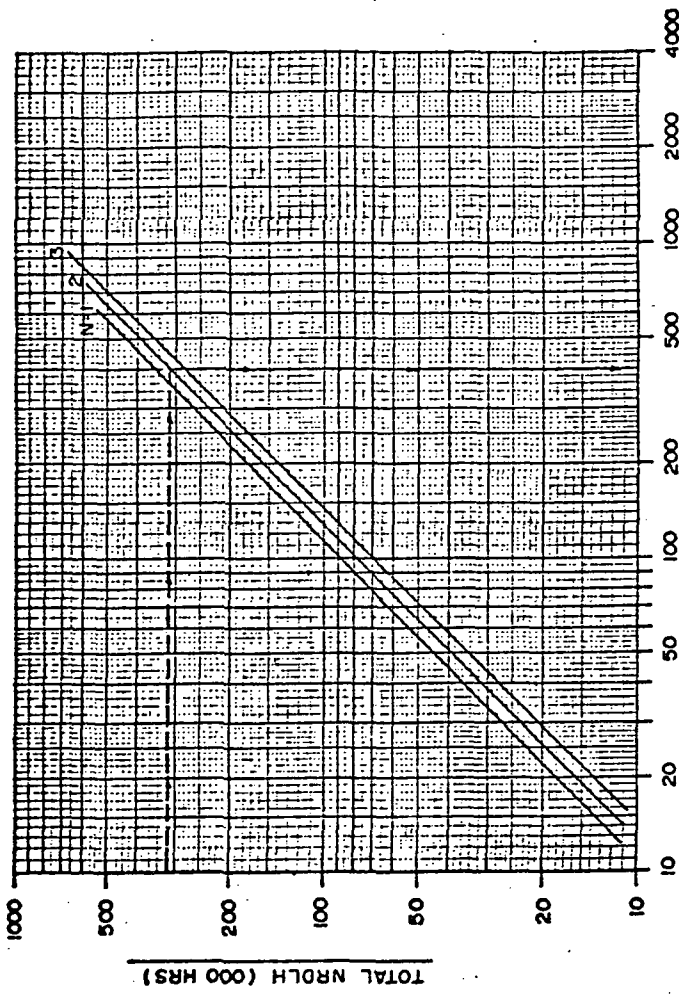
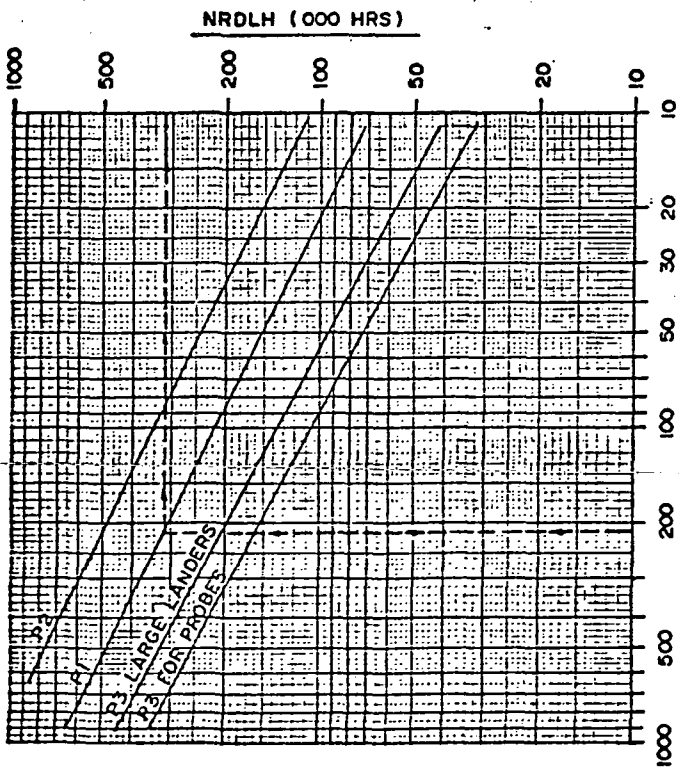

EXAMPLE: MARINER MARS 71

2 FLIGHT ARTICLES

- P1=216 NRDLH P1 = 317.5
- P2=0 NRDLH P2 = 0
- P3=0 NRDLH P3 = 0

TOTAL NRDLH = 317.5
 NRDLH → RDLH = 411.4

PROP \$ = 11.6 MILLION IN FY 75 \$

PROPULSION COST ESTIMATION

Model for Guidance and Control Subsystem

The LER's for the non-recurring and recurring labor hours associated with the guidance and control subsystems development are, respectively:

$$NR_{GC} = 17.79(G1)^{0.722} + 69.6(G2)^{0.607}$$

$$R_{GC} = 0.138(N1)(NR_{GC})$$

G1 is the total subsystem weight (lbs) which includes the attitude control elements and sensors, computer/sequencer, and on-board radar in the case of landing or rendezvous operation

G2 is the weight of the Doppler and range marking radars

N1 is the number of flight articles

The inflated labor dollar rate is:

$$\text{\$ per hour rate} = 4.38(1.059)^{(D2-1964.5)}$$

The Guidance and Control Subsystem cost is 28.5% labor. The limits on the input parameters used in our model are:

<u>Parameter</u>	<u>Min.</u>	<u>Max.</u>
G1	13 lbs	171 lbs
G2	45 lbs	71 lbs

The estimation accuracy for this subsystem was high and both the non-recurring and recurring labor hours are modeled fairly accurately, although the trade-off generally works in favor of smaller total DLH errors. On a statistical basis across the 8 projects, the model is slightly biased towards underestimation with a mean error of -1.6% and a mean absolute error of 3.2%.

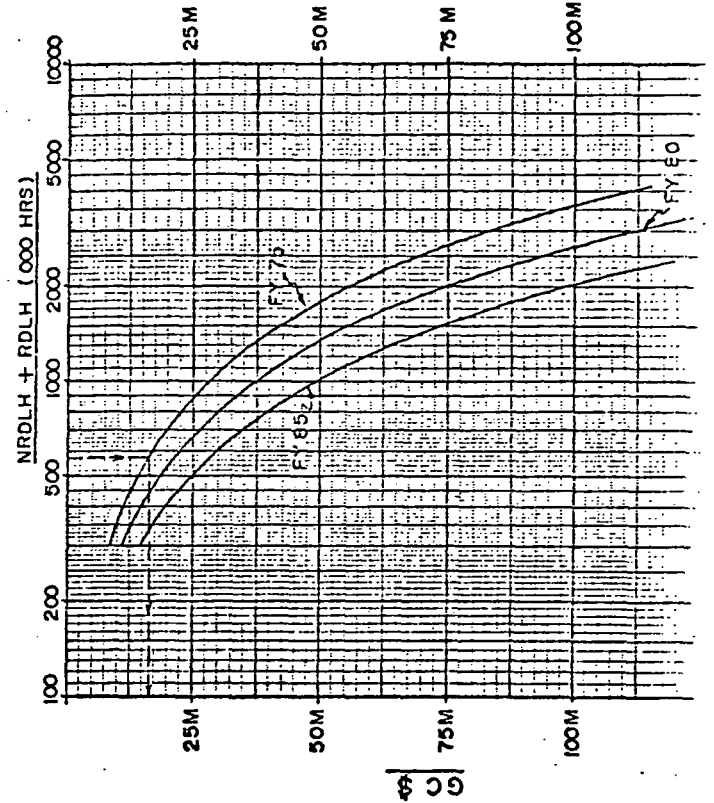
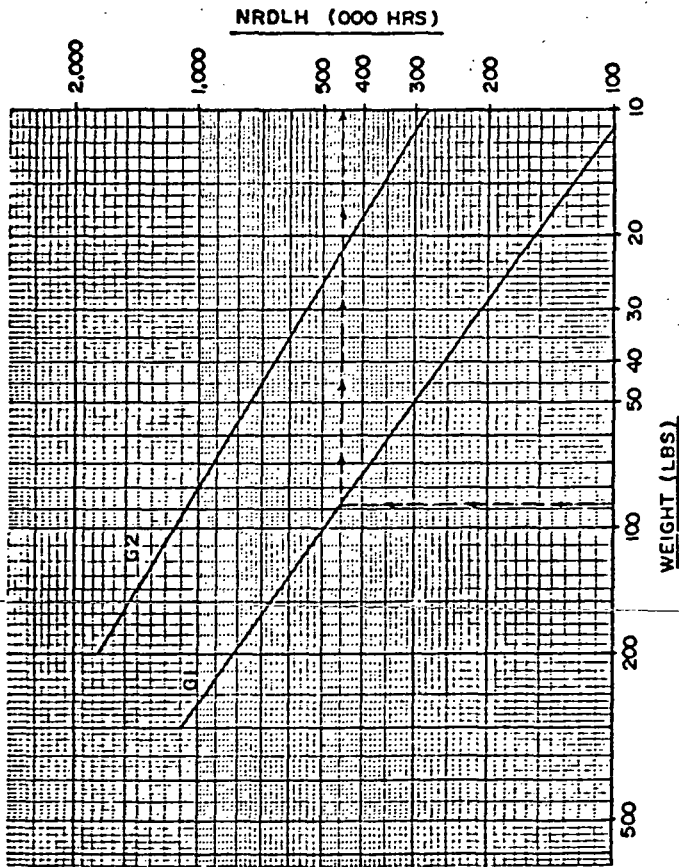
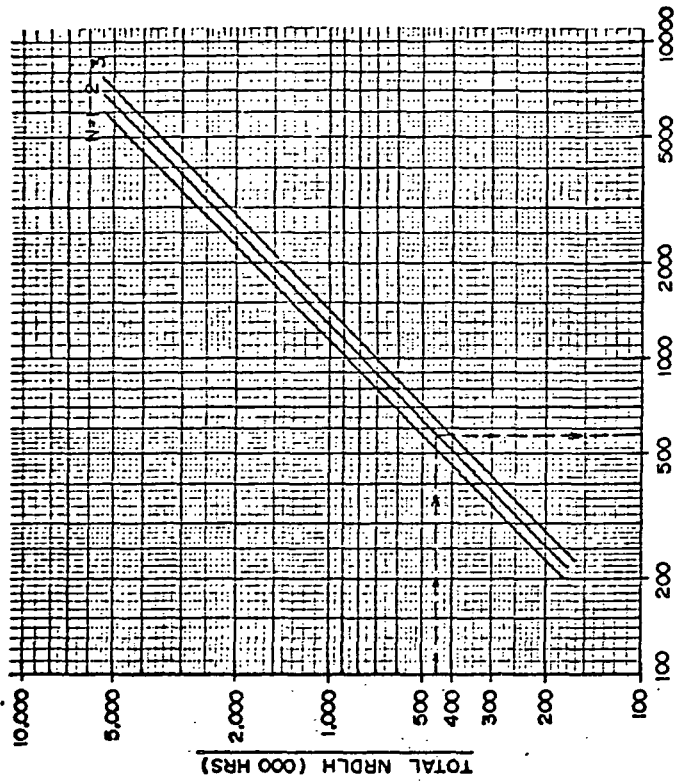

EXAMPLE: MARINER MARS 71

2 FLIGHT ARTICLES /
 G1=68 NRDLH_{G1} = 450.9
 G2=0 NRDLH_{G2} = 0
 TOTAL NRDLH = 450.9
 NRDLH + RDLH = 575.3
 GC \$ = 17.1 MILLION IN FY75

GUIDANCE & CONTROL COST ESTIMATION

Model for Communications Subsystem

This subsystem was modeled in terms of three major functional elements: (1) radio frequency transmitter and receiver assembly; (2) data handling assembly including flight telemetry and command, data storage and data encoding and automation; and (3) the antenna assemblies. The LER's are:

$$NR_C = 7.7(C1)+23.0(C2)^{0.67}+17.0(C3)^{0.5}$$

$$R_C = 0.18(N1)(NR_C)$$

- C1 is the weight (lbs) of the radio frequency system
- C2 is the weight of the data handling system
- C3 is the weight of the antennas
- N1 is the number of flight articles

The inflated labor dollar rate is:

$$\text{\$ per hour rate} = 4.66(1.0404)^{(D2-1964.5)}$$

The Communications Subsystem cost is 29.1% labor. The limits on the input parameters used in our model are:

<u>Parameter</u>	<u>Min.</u>	<u>Max.</u>
C1	23 lbs	108 lbs
C2	12 lbs	107 lbs
C3	7 lbs	46 lbs

On a statistical basis, the mean absolute error is 18.7% and the mean error of -5.1% indicates a bias toward underestimation. In general, the data handling system is fairly well modeled across all 8 projects. The modeling of antenna cost is not too accurate; however, the effect is not very significant because the labor hours associated with antenna design/development are relatively small.

C1
C2
C3

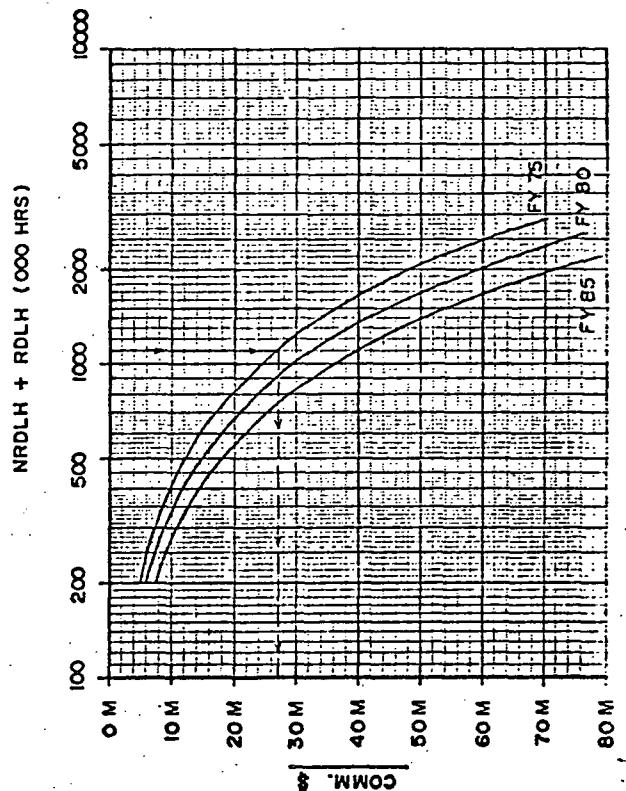
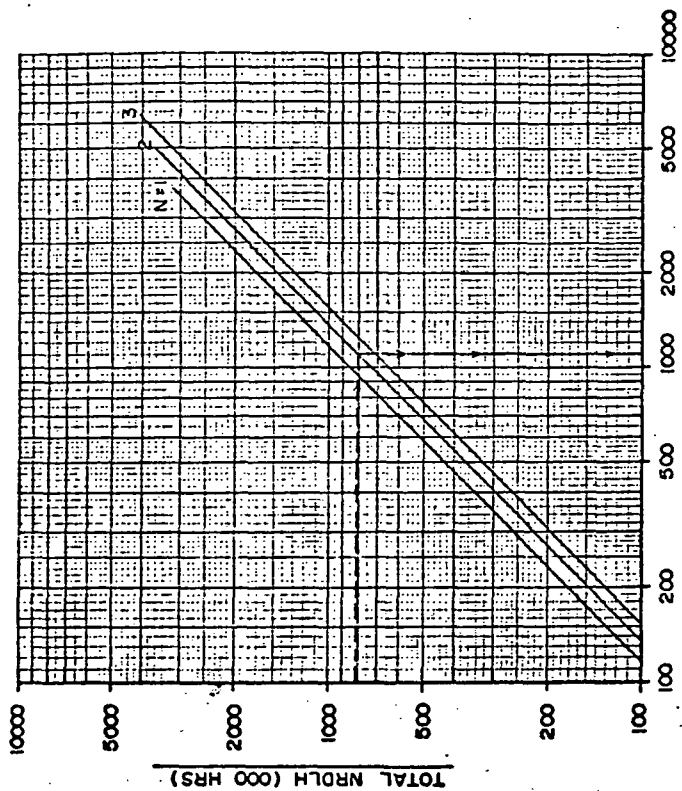
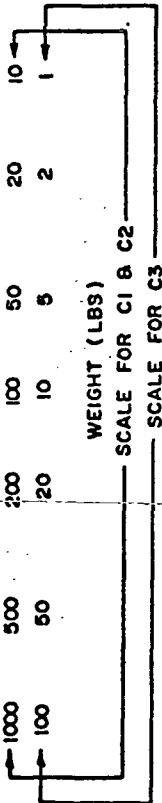
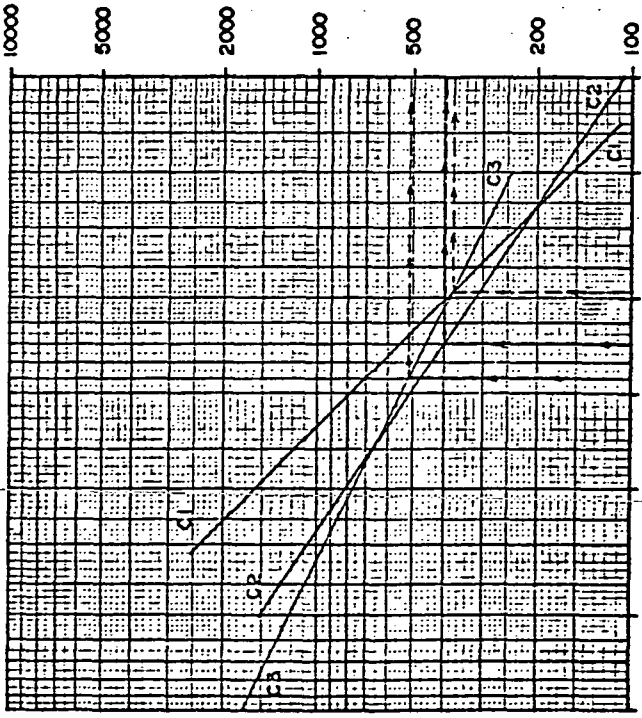

EXAMPLE: MARINER MARS 71

2 FLIGHT ARTICLES

- C1 = 48 NRDLH C1 = 369.6
- C2 = 70 NRDLH C2 = 396.2
- C3 = 8 NRDLH C3 = 61.0

TOTAL NRDLH = 816.8
 NRDLH + RDLH = 1110.8
 COMM. \$ = 26.96 MILLION IN FY75 \$

COMMUNICATIONS COST ESTIMATION

Model for Power Subsystem

The LER's for the non-recurring and recurring labor hours associated with the electrical power subsystem are, respectively:

$$\text{Non-Probe: } NR_{EP} = 0.643(W1)+152$$

$$\text{Probe: } NR_{EP} = 0.643(W1)+50$$

$$R_{EP} = 0.15(N1)(NR_{EP})$$

W1 is the subsystem weight including all power conditioning equipment and auxiliary supplies. In the case of ballistic spacecraft whose primary energy source is solar energy conversion, the weight of the solar arrays is included in W1. When the primary source is radioisotope thermoelectric energy conversion, W1 includes only the conditioning equipment and batteries.

N1 is the number of flight articles.

The inflated labor dollar rate is:

$$\text{\$ per hour rate} = 4.32(1.043)^{(D2-1964.5)}$$

The Power Subsystem cost is 29.8% labor. The limit on the input parameter used in our model is:

<u>Parameter</u>	<u>Min.</u>	<u>Max.</u>
W1	39 lbs	293 lbs

Both the non-recurring and recurring labor are modeled fairly well except for Surveyor which is underestimated. On a statistical basis across the 8 projects, the model is slightly biased toward underestimation and the mean absolute error is 16.4%.

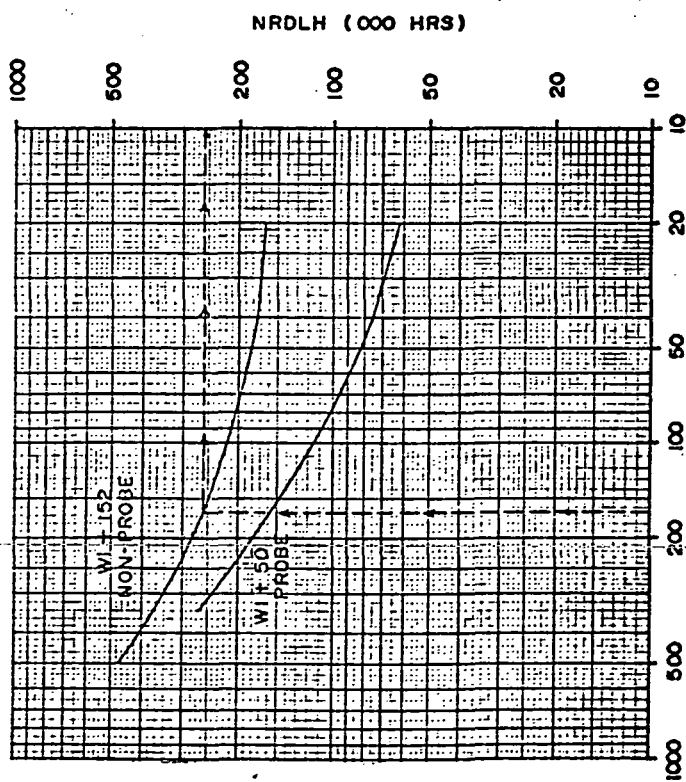
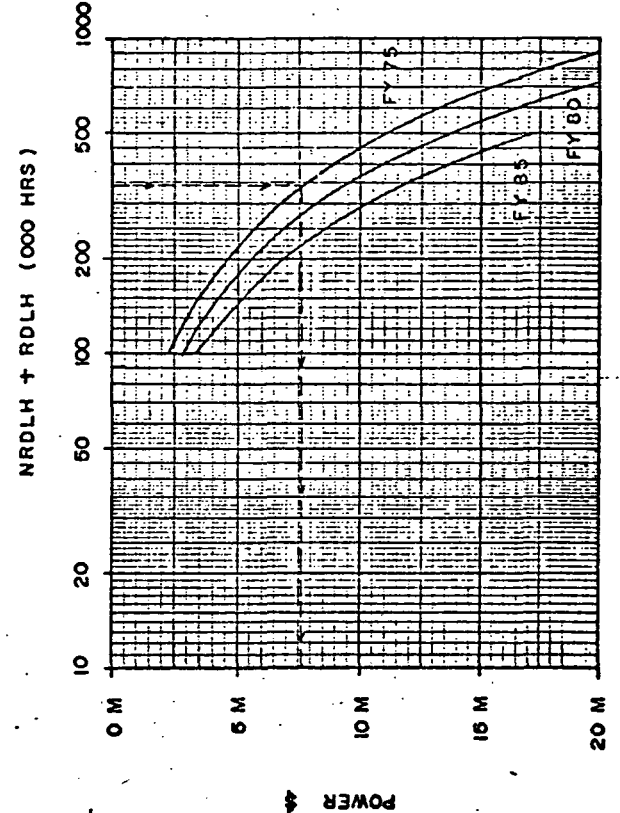
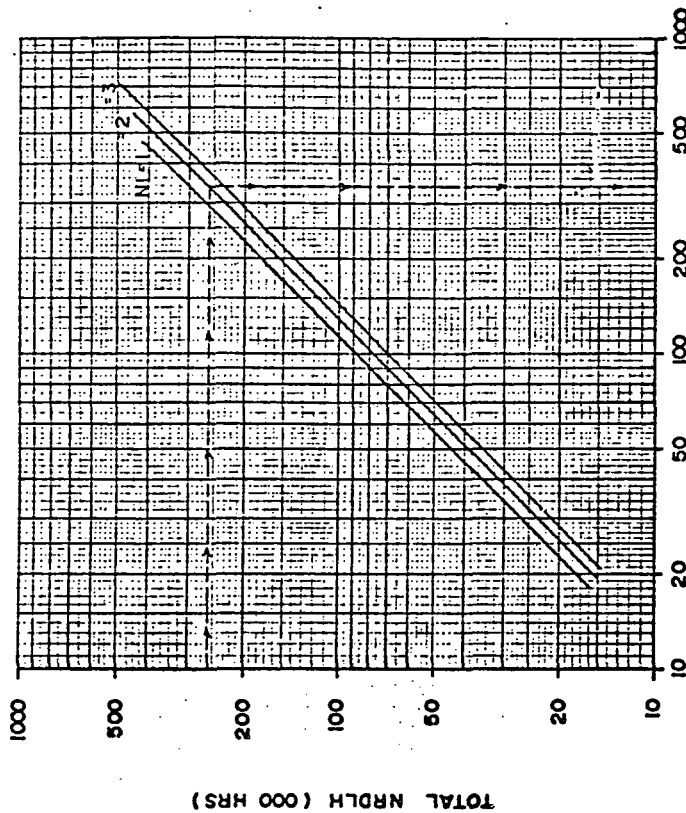

EXAMPLE: MARINER MARS 71

2 FLIGHT ARTICLES
 Wt 165 NRDLH/Wt = 258.1

TOTAL NRDLH = 258.1

NRDLH + RDLH = 335.5

POWER \$ = 7.6 MILLION IN FY 75

POWER COST ESTIMATION

Model for Science Instruments Subsystem

The LER's for the non-recurring and recurring labor hours associated with the science experiments subsystem are, respectively:

$$NR_{SE} = 1.5(Q1) + 11.5(Q2) + 0.105(Q3) + 220$$

$$R_{SE} = 0.237(N1)(NR_{SE})$$

Q1 is the total weight (lbs) of the science experiments

Q2 is the weight of special lander surface instruments that require significant sample manipulation, preparation or processing.

Q3 is the resolution (pixels per line) of the imaging experiment.

N1 is the number of flight articles

The inflated labor dollar rate is:

$$\text{\$ per hour rate} = 5.00(1.04)^{(D2-1964.5)}$$

The Science Experiments Subsystem cost is 27.7% labor. The limit on the input parameters used in our model are:

Parameter	Min.	Max.
Q1	41 lbs	200 lbs
Q2	21 lbs	119 lbs
Q3	200 ppl	5634 ppl

Note that the above LER's apply only to science instruments and not to data analysis and science operations. The model provides extremely good estimation accuracy of total direct labor. The mean error across the 8 projects is 3.1% and the mean absolute error is 3.8%. Good accuracy is also obtained for both non-recurring and recurring labor hours.

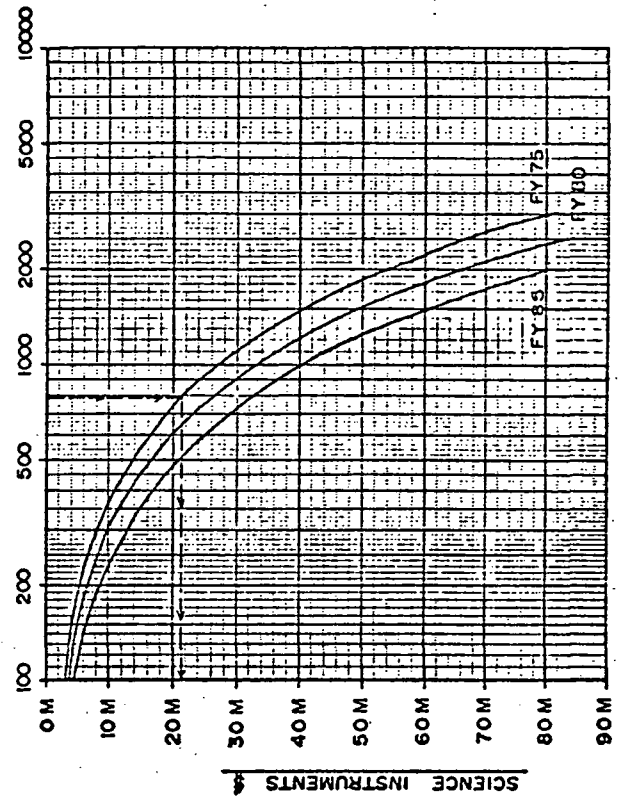
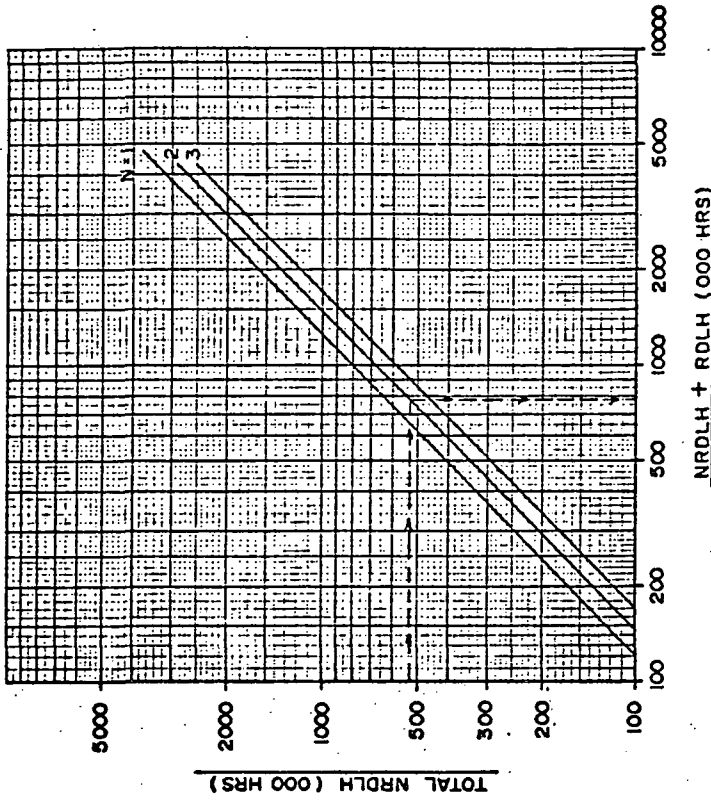
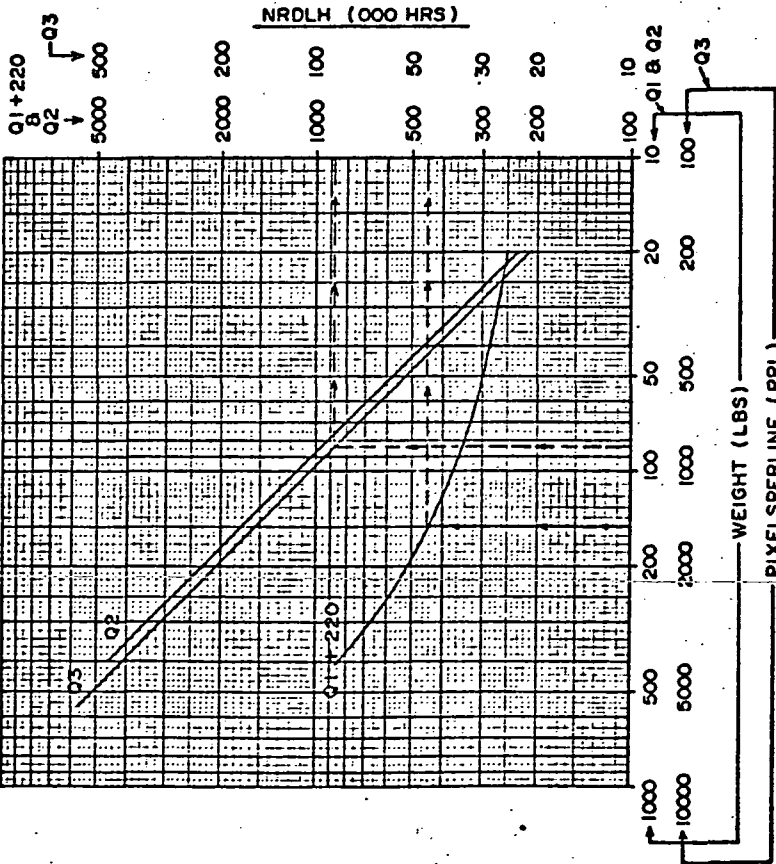

EXAMPLE: MARINER MARS 71

- 2 FLIGHT ARTICLES
- Q1=150 NRDLH_{Q1} = 445
- Q2=0 NRDLH_{Q2} = 0
- Q3=832 NRDLH_{Q3} = 87.4

TOTAL NRDLH = 532.4
NRDLH + RDLH = 784.8

SCIENCE INSTRUMENTS \$ = 21.4 MILLION IN FY 75

SCIENCE INSTRUMENTS COST ESTIMATION

Model for Program Management

The LER for total direct labor hours in program management is an exponential function of the total (non-recurring and recurring) DLH of all subsystem categories.

$$DLH_{PM} = 94.0 e^{2.83 \times 10^{-4} DLH_{SS}}$$

The equation for determining the properly inflated dollar rate for converting labor manhours into labor dollars is:

$$\text{\$ per hour rate} = 5.30(1.047)^{(D2-1964.5)}$$

D2 is the fiscal wage date.

The Program Management support cost is 33.9% labor. The limits on DLH_{SS} used in our model were 1,976,000 hours min. to 11,269,000 hours max.

The above LER was derived from a data fitting procedure which employed the actual value of total DLH_{SS} . If it is assumed that the subsystem categories can be modeled perfectly the LER for Program Management is slightly biased toward underestimation and the mean absolute error is 12.5%. When the LER is actually used for estimation purposes, the estimated value of DLH_{SS} is used the model shows a tendency toward underestimation and the mean absolute error rises to 20.8%. The error in Surveyor has a significant effect on the statistics. Surveyor is underestimated because its value of DLH_{SS} is underestimated and because of the compounding effect of the exponential LER. Without Surveyor, the mean estimation error is -2.7% and the mean absolute error is 16.2%.

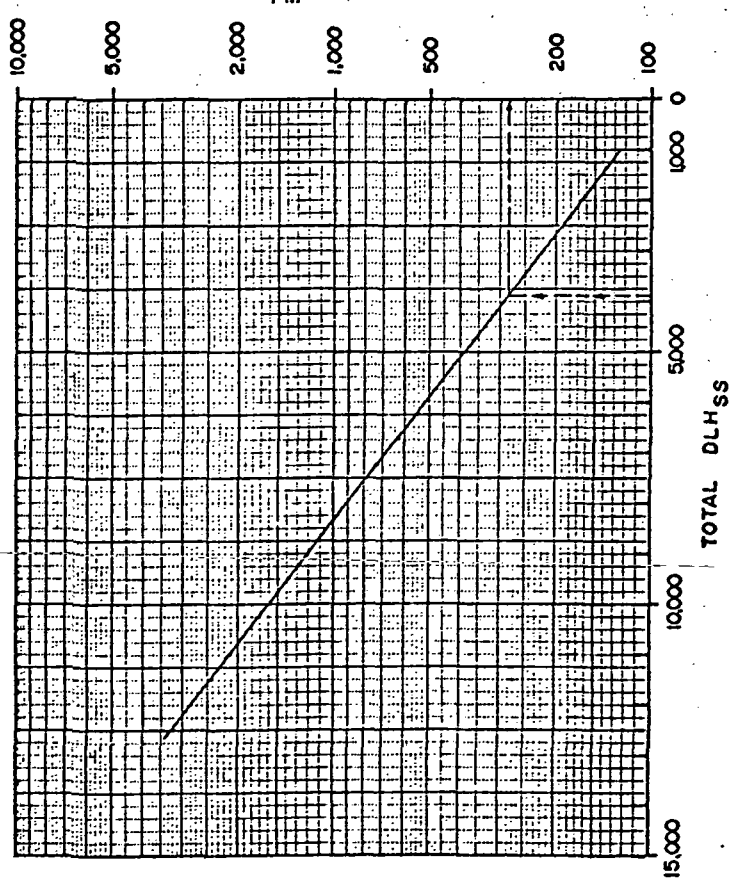
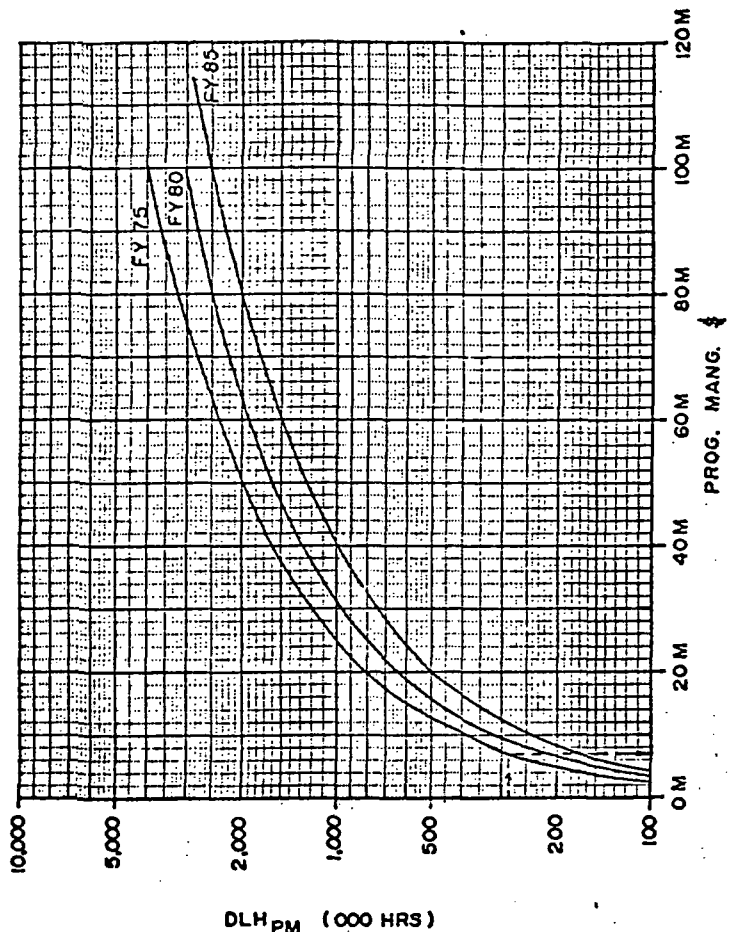

EXAMPLE: MARINER MARS 71

TOTAL DLH_{SS} = 3906

DLH_{PM} = 283.9

PROG. MANG. \$ = 7.2 MILLION IN FY 75 \$

PROGRAM MANAGEMENT COST ESTIMATION

Model for Systems Analysis and Engineering

The LER for total direct labor hours in this support category is a power function of total DLH for all subsystem categories.

$$DLH_{SAE} = 1.94 \times 10^{-8} (DLH_{SS})^{2.76}$$

The equation for determining the properly inflated dollar rate for converting labor manhours into labor dollars is:

$$\text{\$ per hour rate} = 5.53(1.044)^{(D2-1964.5)}$$

D2 is the fiscal wage date.

The System Analysis and Engineering Support cost is 33.7% labor. The limits on DLH_{SS} used in our model was 1,976,000 hours min. to 11,269 hours max.

Using actual values for the variable DLH_{SS} , the model is slightly biased toward underestimation with a mean error of -2.6% and a mean absolute error of 14.3%. When estimated values of DLH_{SS} are used, the mean error changes to -6.7% and the mean absolute error is 28.9%. If the Surveyor point, which was under estimated, was omitted from the statistics, the mean error changes to -0.2%. Notwithstanding the fact that the variance of fit is fairly high, it is still concluded that the effort devoted to systems analysis support is correlated in a functional sense to the effort involved in spacecraft subsystem design and development.

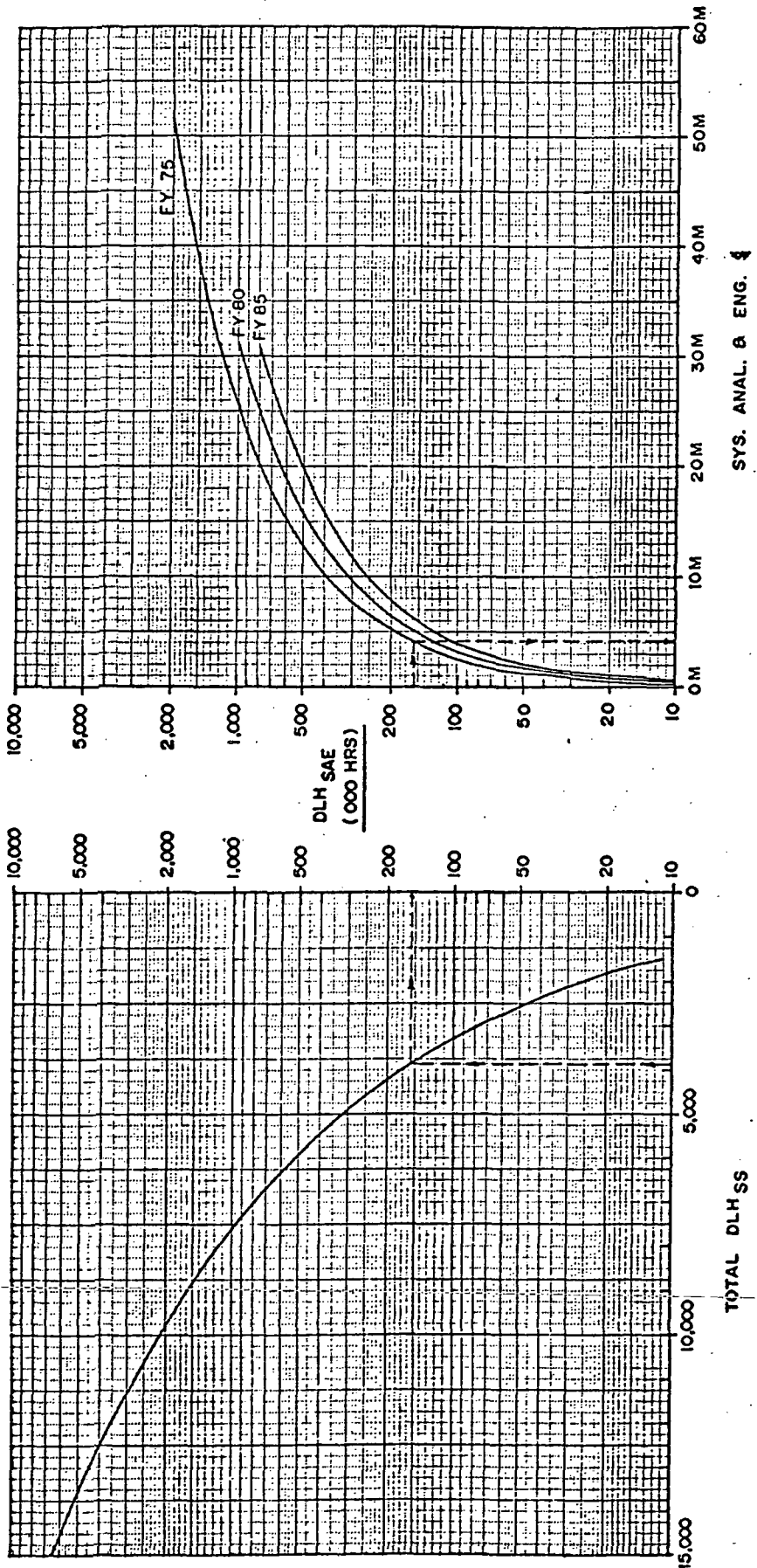

EXAMPLE: MARINER MARS 71

TOTAL DLH \$\$ = 3906

DLH SAE = 158.85

SYS. ANAL. & ENG. \$ = 4.1 MILLION IN FY 75 \$

SYSTEMS ANALYSIS & ENGINEERING COST ESTIMATION

Model for Test and Quality Assurance/Reliability

The LER for total direct labor hours is an exponential function of total DLH for all subsystem categories.

$$DLH_T + DLH_{QAR} = 226 e^{2.82 \times 10^{-4} DLH_{SS}}$$

The equation for determining the properly inflated dollar rate for converting labor manhours into labor dollars is:

$$\text{\$ per hour rate} = 4.65x(1.051)^{(D2-1964.5)}$$

D2 is the fiscal wage date.

The Test and Quality Assurance/Reliability Support cost is 32.4% labor. The limit on DLH_{SS} used in our model was 1,976,000 hours min. to 11,269,000 hours max.

The exponential form of the LER can be quite sensitive to the value of DLH_{SS}. This was particularly evident in the missions where the modeled DLH_{SS} total was considerably higher or lower than the actual DLH_{SS} total. Using actual values for DLH_{SS} the mean error is 4.6% and the mean absolute error is 16.5%. When the estimated values of DLH_{SS} are used, the mean error is -4.2% and the mean absolute error is 19.9%.

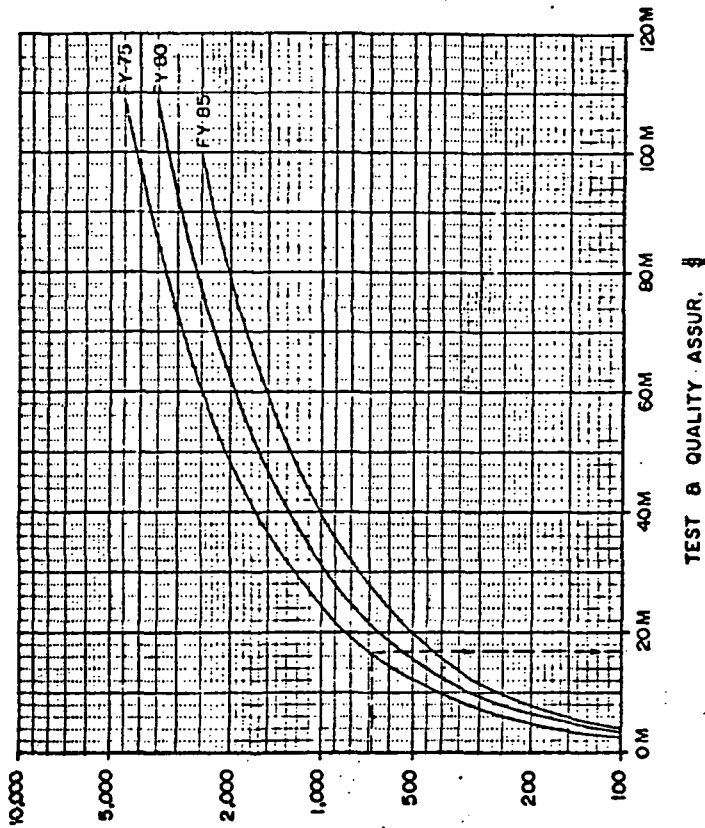
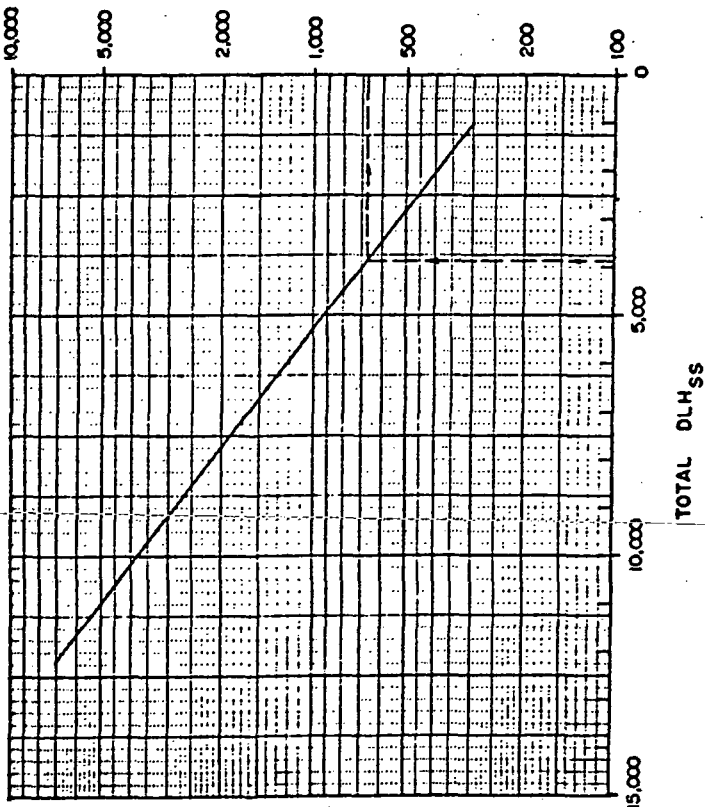

EXAMPLE: MARINER MARS 71

TOTAL DLH_{SS} = 3906

DLH T80A = 679.9

TEST & QUAL. ASSUR. $\$$ = 16.5 MILLION IN FY 75 $\$$

TEST & QUALITY ASSURANCE COST ESTIMATION

Model for Assembly and Integration

The LER for total direct labor hours in this support category is a power function of total DLH for all subsystem categories.

$$DLH_{AI} = 7.82 \times 10^{-4} (DLH_{SS})^{1.47}$$

The equation for determining the properly inflated dollar rate for converting labor manhours into labor dollars is:

$$\text{\$ per hour rate} = 5.27 \times (1.042)^{(D2-1964.5)}$$

D2 is the fiscal wage date.

The Assembly and Integration Support cost is 32.9% labor.

Using actual values for DLH_{SS} , the mean error was -5.4% and the mean absolute error was 21.5%. When the estimated values for DLH_{SS} are used, the mean error is -5.5% and the mean absolute error is 33.3%.

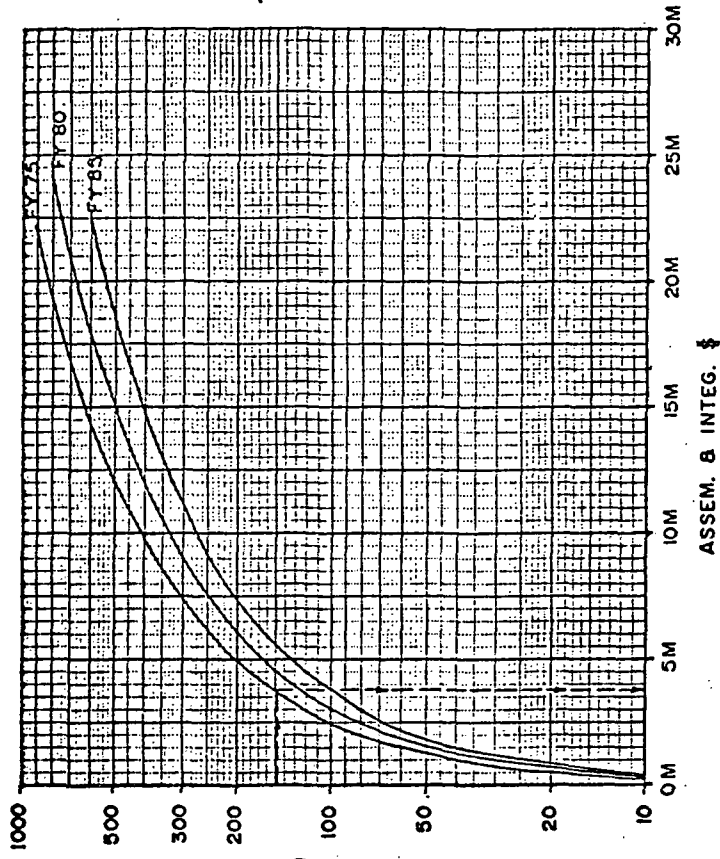
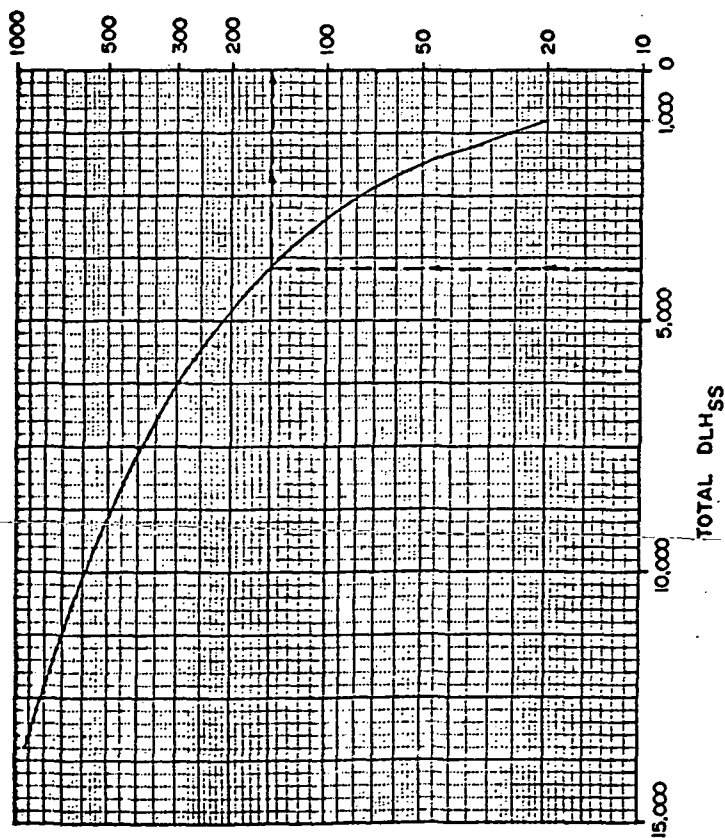

EXAMPLE: MARINER MARS 71

TOTAL DLH_{SS} = 3906

DLH AI = 148.95

ASSEM. & INTEG. \$ = 3.67 MILLION IN FY 75 \$

ASSEMBLY & INTEGRATION COST ESTIMATION

Model for Ground Equipment

The LER for total direct labor hours in Ground Equipment is an exponential function of total DLH for all subsystem categories except structure and a time factor to account for inheritance in ground equipment from earlier projects.

$$DLH_{GE} = 0.033x(DLH_{SS} - DLH_{ST})^{1.1} / (1 - 0.7e^{-D3/2})$$

D3 is the launch date minus 1971. (Zero for a launch before 1971.)

The equation for determining the properly inflated dollar rate for converting labor manhours into labor dollars is:

$$\text{\$ per hour} = 4.69x(1.06)^{(D2-1964.5)}$$

The Ground Equipment Support cost is 29% labor.

The relationship for Ground Equipment comes largely from the OSE costs associated with each subsystem except structure. The time factor represents a discount for the most recent missions due to inheritance of technology and equipment. When actual values are used for DLH_{SS} and DLH_{ST} , the mean error is 8.1% and the mean absolute error is 15.6%. When the estimated values are used for DLH_{SS} and DLH_{ST} , the mean error is 7.4% and the mean absolute error is 20.7%.

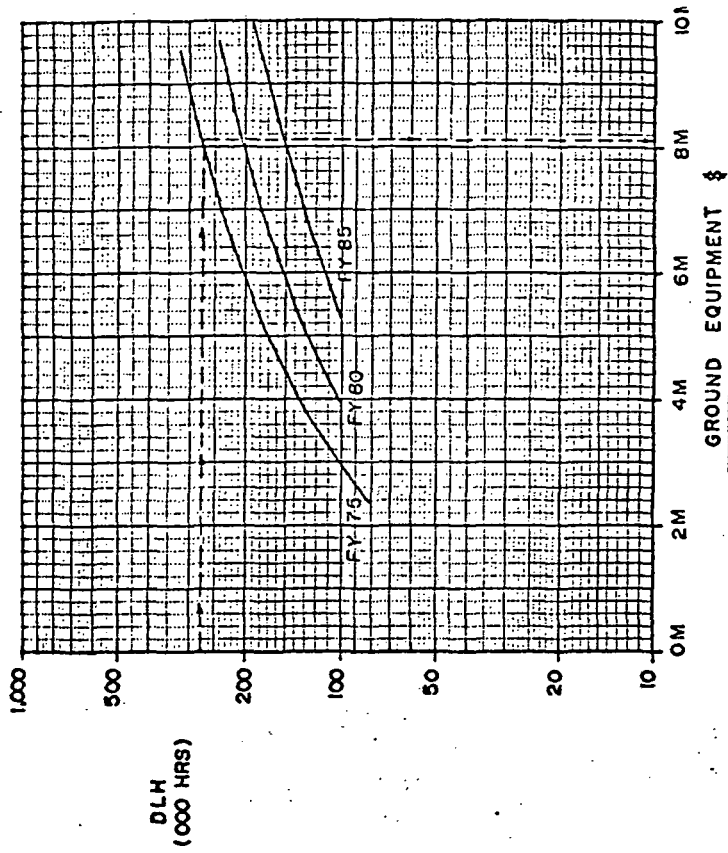
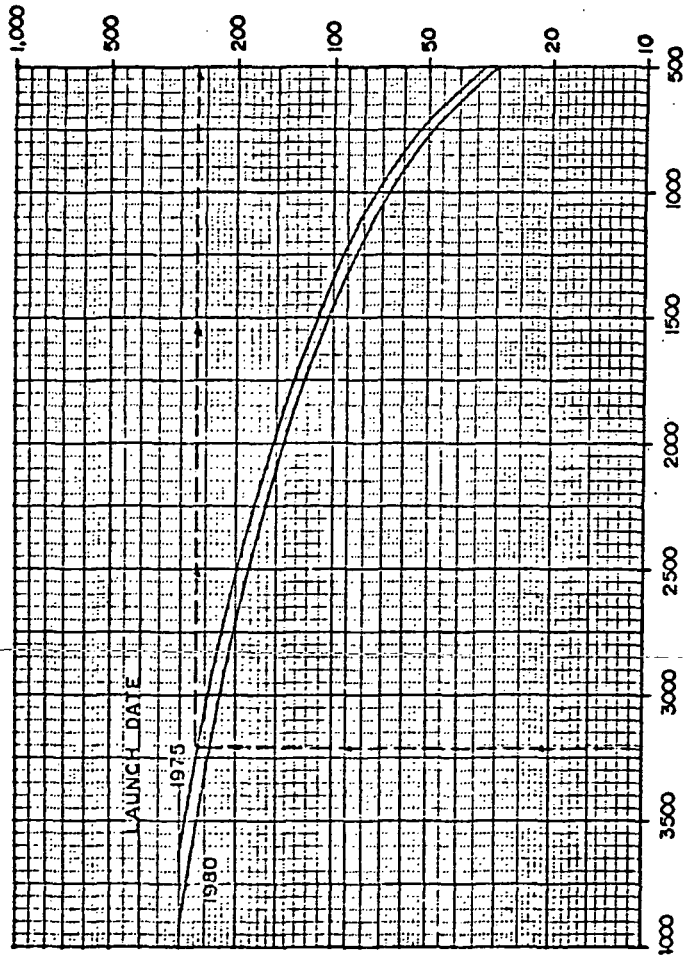

EXAMPLE: MARINER MARS 71

2 FLIGHT ARTICLES

DLH_{SS} - DLH_{ST} = 3217

LAUNCH DATE = MAY, 1971

TOTAL DLH = 270.3

GROUND EQUIPMENT \$ = 6.1 MILLION IN FY 75 \$

GROUND EQUIPMENT COST ESTIMATION

Model for Launch/Flight Operations

The LER for total direct labor hours in launch and flight operations is a function of the number of launches, the mission duration and the number of encounters.

$$DLH_{LFO} = 90xN1 + 3xK1 + 25xK2 + K3xK4$$

- N1 is the number of flight articles
- K1 is the mission duration in months
- K2 is the total encounter time of the prime mission
- K3 is the number of encounter start ups
- K4 is the total number of science teams during encounter

The equation for determining the properly inflated dollar rate for converting labor manhours into labor dollars is:

$$\text{\$ per hour} = 4.69x(1.06)^{(D2-1964.5)}$$

The Launch/Flight Operations Support cost is 29.0% labor. The limits on the input parameters used in our model are:

<u>Parameter</u>	<u>Min.</u>	<u>Max.</u>
K1	5 mo	42.6 mo
K2	0.3 mo	6.0 mo
K3	1	10
K4	1	10
DLH _{SS}	1,976,000	11,269,000

The mean error of the 8 projects is 5.2% and the mean absolute error is 14.5%.

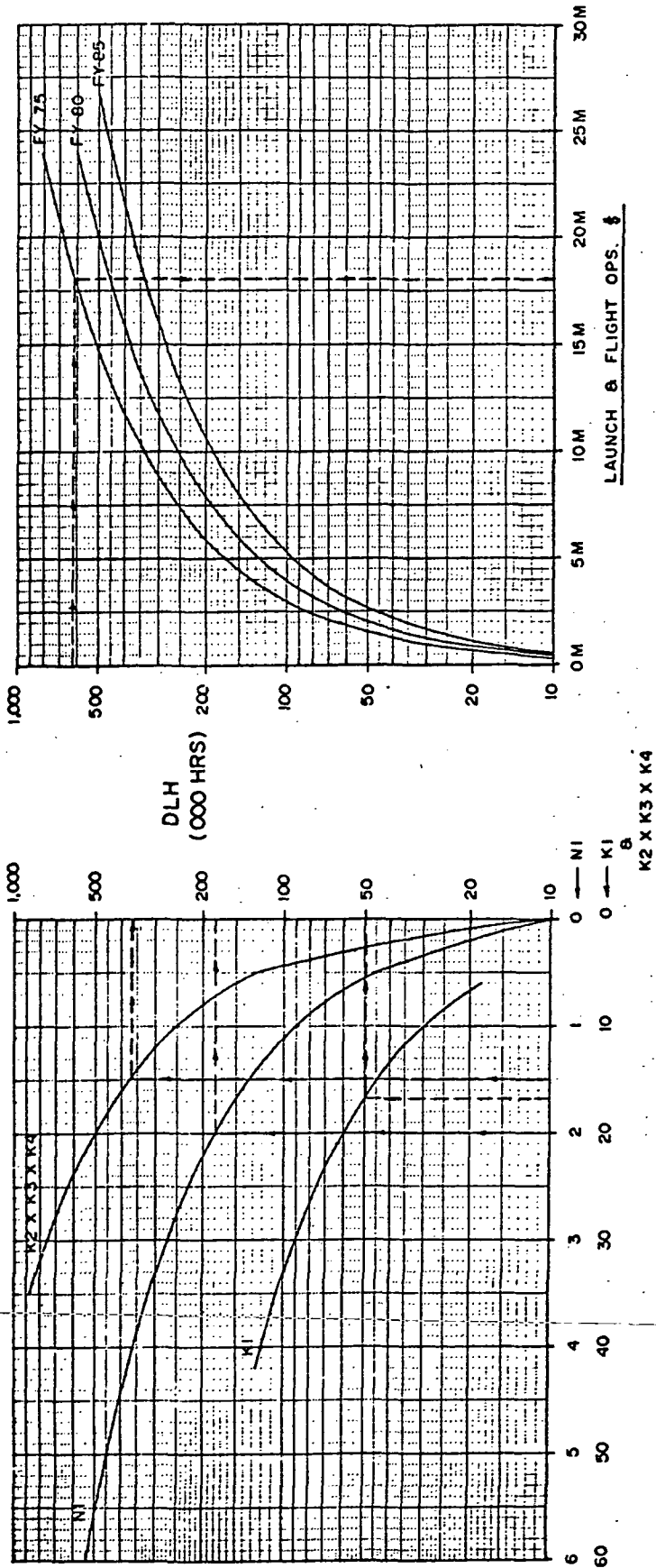

EXAMPLE: MARINER MARS 71

2 FLIGHT ARTICLES

NI = 2 K2 = 3 MO.

KI = 16.7 MO. K3 = 1

K4 = 5

TOTAL DLH = 605.1

LAUNCH & FLIGHT OPS. \$ = 18.04 MILLION IN FY 75 \$

LAUNCH & FLIGHT OPERATIONS COST ESTIMATION

Model for Data Analysis

The LER for total direct labor hours in data analysis is a function of the mission and a time factor to account for the increased sophistication of data analysis with time.

$$DLH_{DA} = 10x(15 + (K2xK3xK4)) \times (1 - 0.82e^{(-D4/3)})$$

K2 is the total encounter time of the mission

K3 is the number of encounter startups

K4 is the number of science teams during encounter phase

D4 is the launch date minus 1966.2 (Zero for launch before 1966.2)

The equation for determining the properly inflated dollar rate for converting labor manhours into labor dollars is:

$$\text{\$ per hour} = 4.69x(1.06)^{(D2-1964.5)}$$

The Data Analysis Support cost is 29% labor. The limits on the input parameters used in our model are:

<u>Parameter</u>	<u>Min.</u>	<u>Max.</u>
K2	0.3 mo	6 mo
K3	1	10
K4	1	10
DLH _{SS}	1,976,000 hrs	11,269,000 hrs

In general, data analysis is a small percentage of a program. The time factor is an escalation due to the increased sophistication of data analysis with time. The mean error of this model is 4.7% and the mean absolute error is 13.9%.

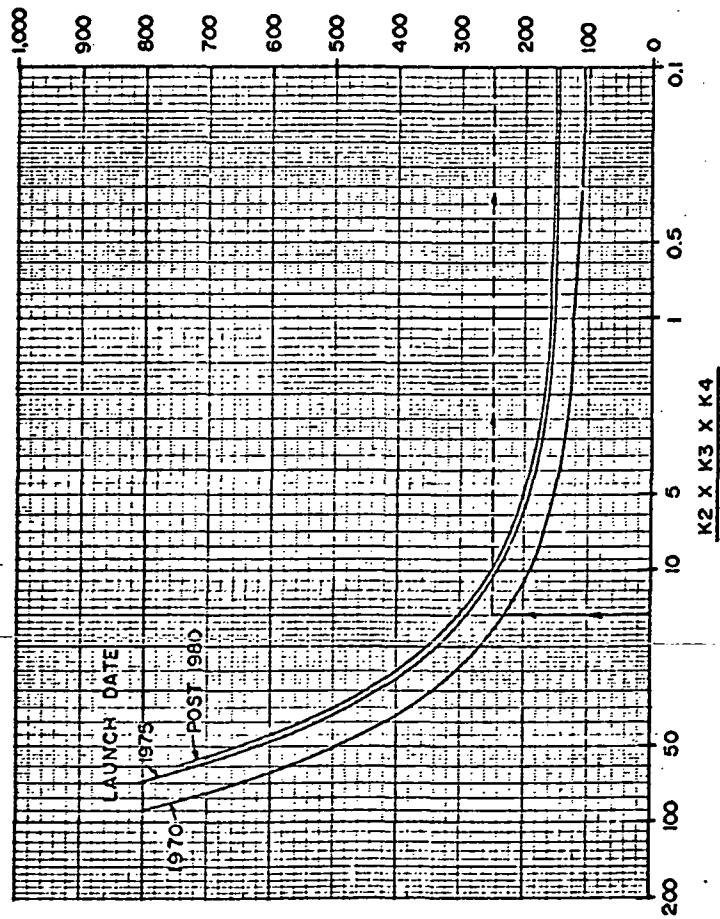
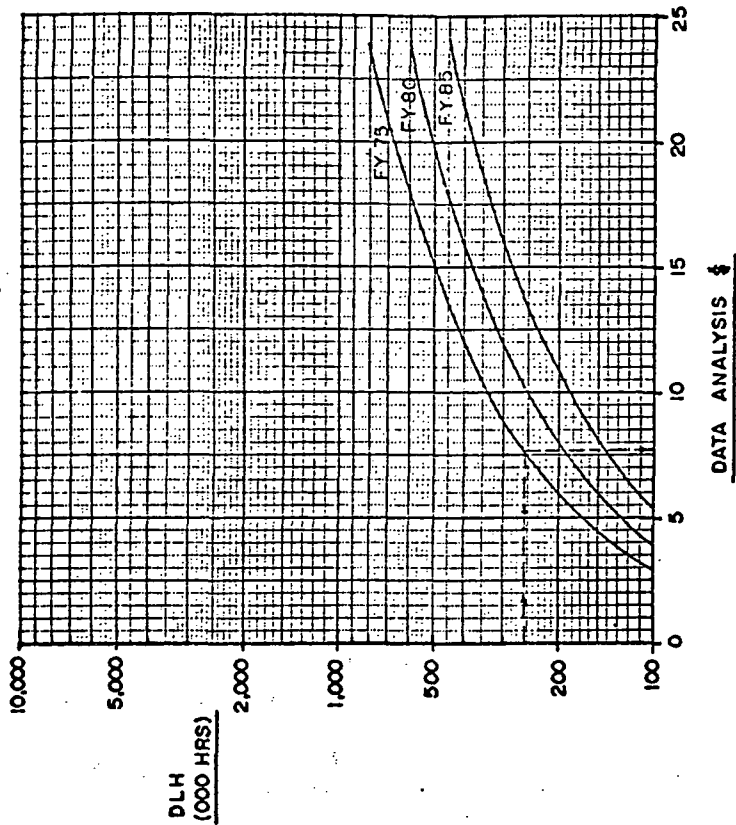

EXAMPLE: MARINER MARS 71

2 FLIGHT ARTICLES
 K2=3
 K3=1
 K4=5

LAUNCH DATE = MAY, 1971

TOTAL DLH = 257.4

DATA ANALYSIS \$ = 7.64 MILLION IN FY 75 \$

DATA ANALYSIS COST ESTIMATION

Model for RTG Cost

Reimbursable costs charged to NASA for RTG power supplies is made up of two parts: (1) the recurring or unit cost, and (2) the fuel loading cost which has been set at about \$650 per thermal watt of radioisotope fuel for the 1970-1980 time period. The equation for CRTG is:

$$\text{CRTG} = \text{N1} \times \text{N2} \times \text{L1} \times 650 + \text{N2} \times 100,000$$

N1 is the number of flight articles

N2 is the number of RTG units per spacecraft

L1 is the RTG fuel loading in thermal watts

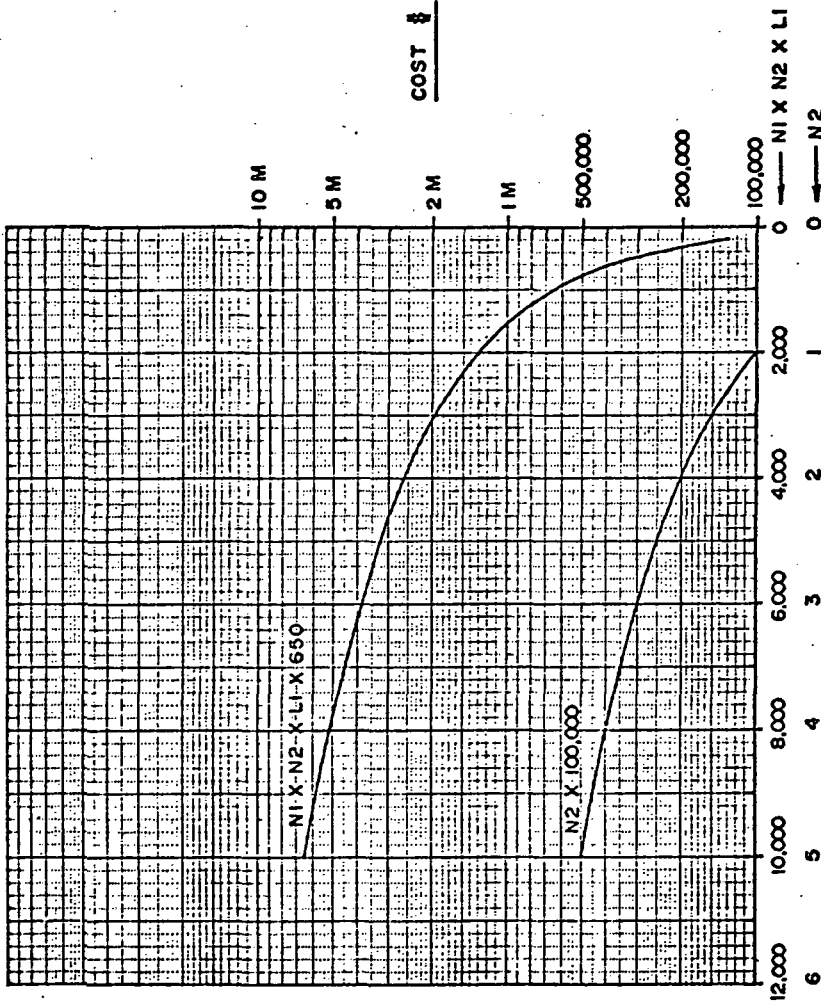

EXAMPLE: MARINER MARS 71

N1 = 2

N2 = 0

LI = 0

COST \$ = 0.00

RTG COST ESTIMATION

TOTAL PROJECT COST ESTIMATES

Results obtained from the present manpower/cost estimation model are quite acceptable when tested against the data base from which the model is derived. Out of the 8 projects only Surveyor and Viking Lander are underestimated by large percentages, 28.8% and 24.6%, respectively. Since Surveyor represented the most complex unmanned space project undertaken in the early 1960's and Viking Lander represents the most complex unmanned space project to date, both of these missions derived essentially zero inheritance from previous design/development experience. There is some evidence to indicate that the design/development experience which was available to these missions was below the norm for other missions. This is a form of negative inheritance or an increased amount of design/development which these missions had to pay for. It is not surprising then that the present model underestimates the cost of these two missions.

Summary Error Analysis of
Total Project Cost Model

<u>Project</u>	<u>Actual (\$M)</u>	<u>Estimated (\$M)</u>	<u>% Error</u>
Mariner '64	78.6	74.7	-5.0
Mariner '69	126.3	110.6	-12.4
Mariner '71	122.4	134.3**	9.7
Pioneer F/G*	83.8	95.9	14.4
Viking Orbiter	244.3	232.0	-5.0
Lunar Orbiter	139.2	155.7	11.8
Viking Lander*	520.3	392.4	-24.6
Surveyor	420.4	299.2	-28.8
With Surveyor			Mean Error = -5.0%
{			Mean Absolute Error = 14.0%
Without Surveyor and Viking Lander			Mean Error = 2.3%
{			Mean Absolute Error = 9.7%

* RTG's included
**with inheritance

Distribution of Costs for Subsystems

As a basis for the inheritance modeling the spacecraft costs have been broken down beyond the normal non-recurring/recurring split. Shown below is the average distribution of costs for the 8-project data base.

	<u>% Total Cost</u>	<u>% NRDLH*</u>	<u>% RecDLH*</u>
Design (NR)	15	19	-
Assembly & Test (NR)	23	29	-
Development (NR)	40	52	-
Materials (3 units NR)	7	-	-
Sub Total (NR)	<u>85%</u>	<u>100%</u>	
Assembly*Test (Rec, 1F/A)	12	-	100%
Materials (Rec, 1 F/A)	3	-	-
Sub Total (Rec)	<u>15%</u>	<u>-</u>	<u>100%</u>
Total	<u><u>100%</u></u>	<u><u>100%</u></u>	<u><u>100%</u></u>

*Excluding materials since they are included in % labor fraction of our cost model.

Model Inheritance Classes

- **Class One: Off-the-Shelf.**

The subsystem is taken off of the shelf in working condition or ordered while the normal production line is operating as an additional unit.

- Inheritance = 100% of non-recurring cost (NRC)
- Cost = recurring cost (RC)

- **Class Two: Exact Repeat of Subsystem.**

The exact repeat of previous subsystem but to be used in slightly different spacecraft or after line has closed down. Only design work is needed.

- Inheritance = 80% of NRC
- Cost = 20% of NRC + 100% of RC

- **Class Three: Minor Modifications of Subsystem.**

A previous design is required but it requires minor modifications. Thus, the spacecraft will still incur all the design cost and most of the test and development cost in ensuring compatibility of the old design and the new minor mods with the new use of the subsystem.

- Inheritance = 25% NRC
- Cost = 75% of NRC + 100% of RC

- **Class Four: Major Modifications of Subsystem.**

A previous design is required but major modifications have to be made to the design. This gets very close to a new subsystem since even new subsystems rely on previous design and experience. *Some savings in development is possible.*

- Inheritance = 5% NRC
- Cost = 95% of NRC + 100% RC

Inheritance

As a basis for our inheritance modeling we have broken down total spacecraft costs beyond the normal non-recurring/recurring split. We have looked particularly at the support categories since they refer to the design, assembly and test of putting together subsystems. Given the distribution of effort in the support categories, it is possible to gain an insight into the savings made possible by inheritance.

For each of the spacecraft subsystems, the model requires the percent of each class of inheritance. The program then computes an inherited non-recurring cost and a recurring cost for each subsystem. Then the support categories are computed using the same LER's but based on the reduced subsystem direct labor hours. No further discount is specifically introduced for the support categories but they simply benefit from the lower subsystem costs.

"NORMAL" OUTPUT FROM
MANPOWER/COST MODEL
85% Non-Rec 15% Rec

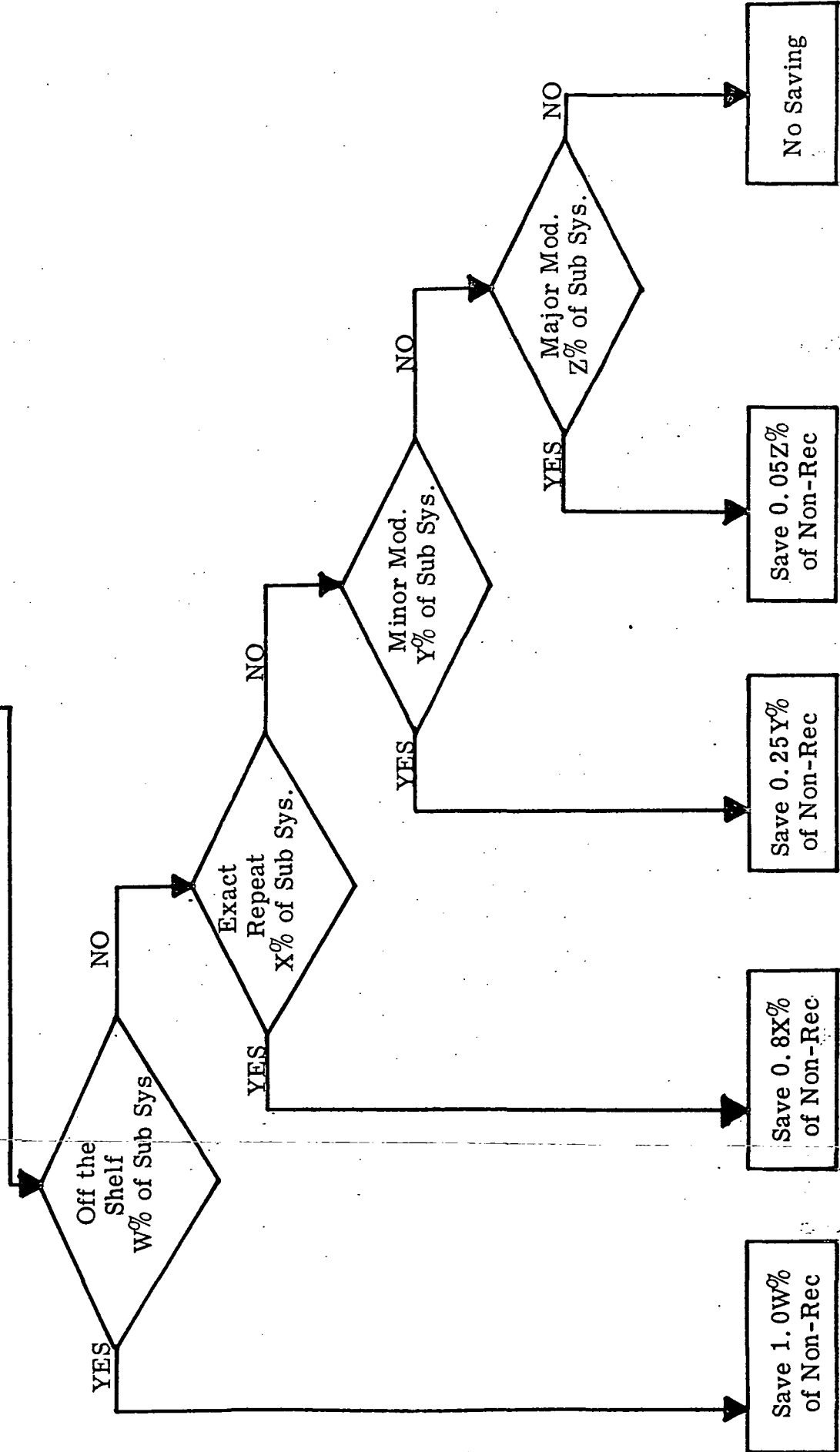

LOGIC FOR INHERITANCE COST SAVINGS

Inheritance Effect on MVM '73 Estimate

● Inheritance Percentages	Classes			
	<u>1</u>	<u>2</u>	<u>3</u>	<u>4</u>
Structure	0	0	50	0
Propulsion	0	50	50	20
Guidance & Control	0	50	25	20
Communications	0	75	50	10
Power	0	25	75	25
Science Instruments	0	20	70	0

Results of Inheritance Effect on MVM '73 Estimate

Subsystem Categories	Cost (Millions)		Direct Labor (000 Hours)	
	Normal	With Inheritance	Normal	With Inheritance
Structure	16.5	15.0	645	587
Propulsion	3.7	2.0	131	72
Guidance & Control	14.9	8.7	530	311
Communications	28.5	10.8	1174	447
Power	6.5	4.4	287	196
Science Instruments	18.9	14.1	692	519
Subtotal	88.8	55.1	3459	2132
Support Categories				
Program Management	6.3	4.4	250	172
Systems Analysis/Eng	2.9	0.8	114	30
Test + Quality Assurance	14.5	10.0	599	412
Assembly and Integration	3.1	1.5	125	61
Launch and Flight Ops	11.9	11.9	400	400
Ground Equipment	7.4	3.8	247	128
Data Analysis	12.6	12.6	421	421
Subtotal	58.7	44.9	2156	1624
TOTAL	147.5	100.1	5615	3756

SECTION 3

SAMPLE
MODEL
APPLICATIONS

EXAMPLE

Shown below is a sample of the output of the SAI model. To reduce the turnaround time the model has been automated. The format of the output is as follows:

- Section 1 A list of the input parameters used for the mission.
- Section 2 The percentage of each subsystem that is subject to the three levels of inheritance: Exact repeat, Minor modification of subsystems and Major modifications of subsystems.
- Section 3 The computed non-recurring and recurring hours, the total direct labor hours and the computed cost for each of the six spacecraft subsystems. Also shown are the same parameters when the above degree of inheritance is assumed.
- Section 4 The system support costs associated with integrating all the subsystems into a fully tested spacecraft.
- Section 5 The total labor hours and dollars including RTG costs where appropriate, and the computed cost of an additional flight unit.
- Section 6 Cost spreads for five and four year programs. The cost spread includes the run out costs for Launch and Flight Operations and Data Analysis.

LABOR AND COST ESTIMATION RESULTS

PROJECT NAME MARINER JUPITER/SATURN RUN DATE FEB. 14, 1975

PROJECT DESCRIPTION WEIGHT UNITS(POUNDS), POWER UNITS(WATTS)
 LAUNCH DATE (Z\$) 9/1977 MECHANISMS/LB WT(S2) 27.0 TOTAL SCIENCE WT(Q1) 154.0
 FISCAL WAGE DATE(DZ) 1975.0 TC PYRO. CABL. WT (S3) 131.0 PIXELS/LINE (TV)(Q3) 814.0
 FLIGHT ARTICLES (N1) 2.0 PROP. SYS DRY WT (P1) 47.0 MIS DURATION(MD)(K1) 45.0
 NON-RTG POWER WT(W1) 73.0 TOTAL G/C WT (G1) 222.0 ENCOU TIME (MD) (K2) 4.0
 RTG UNIT PER S/C(N2) 3.0 RADIO COMM. WT (C1) 106.0 NO. ENC START UP(K3) 2.0
 RTG FUEL LOADING(L1) 2500.0 DATA HANDLING WT(C2) 76.0 NO. SCI. TEAMS (K4) 4.0
 TOTAL STRUCT. WT(S1) 438.0 ANTENNA WT (C3) 14.0

INHERITANCE % STR PROP G/C COMM FOW SCI
 EXACT REPEAT OF SUBSYS 5% 0% 0% 20% 0% 0%
 MINOR MODIFICATION OF SUBSYS 20% 50% 20% 15% 0% 0%
 MAJOR MODIFICATION OF SUBSYS 75% 50% 80% 65% 0% 20%

 COST DIRECT LABOR NON-RECURRING RECURRING
 (MILLIONS) (000 HRS) (000 HRS) (000 HRS)
 SUBSYSTEM CATEGORIES NORM INHER INHER INHER INHER INHER
 STRUCTURE 16.2 14.7 635 575 521 479 114 95
 PROPULSION 5.4 4.9 192 173 148 133 44 39
 GUIDANCE AND CONTROL 31.5 29.4 1122 1048 880 844 243 204
 COMMUNICATIONS 42.9 34.9 1766 1440 1298 1052 467 388
 POWER 5.8 5.8 259 259 199 199 60 60
 SCIENCE INSTRUMENTS 21.6 21.3 791 781 537 537 254 244

SUBTOTAL 123.3 111.0 4764 4275 3583 3244 1182 1031

SUPPORT CATEGORIES
 PROGRAM MANAGEMENT 9.2 8.0 362 315
 SYSTEMS ANALYSIS/ENG. 7.1 5.3 275 204
 TEST + QUALITY ASSURANCE 21.0 18.3 866 755
 ASSEMBLY AND INTEGRATION 4.9 4.2 199 170
 LAUNCH AND FLIGHT OPS. 33.2 33.2 1115 1115
 GROUND EQUIPMENT 9.6 8.5 321 285
 DATA ANALYSIS 13.8 13.8 462 462

SUBTOTAL 98.7 91.2 3600 3305

 TOTAL (WITHOUT RTG) 222.1 202.2 8365 7580
 RTG COST = 10.1

TOTAL 232.1 212.2
 ADDL. FLIGHT UNIT = 33.4

 FISCAL YEAR 1975 1976 1977 1978 1979 1980 1981 1982 1983 1984 1985 1986
 NORMAL 32.4 62.6 53.7 28.5 25.9 4.7 15.3 4.2 2.7 2.0 0.0 0.0
 COMPRESSED 9.0 74.8 67.2 31.4 22.5 2.9 15.3 4.2 2.7 2.0 0.0 0.0

LABOR AND COST ESTIMATION RESULTS

PROJECT NAME PIONEER SATURN/URANUS FLYBY (WITH SATURN PROBE) RUN DATE FEB. 14, 1975

PROJECT DESCRIPTION WEIGHT UNITS(POUNDS), POWER UNITS(WATTS)
 LAUNCH DATE (Z\$) 12/1982 TC PYRO. CABL. WT (S3) 84.0 ANTENNA WT (C3) 56.0
 FISCAL WAGE DATE(D2) 1975.0 PROP. SYS DRY WT (P1) 37.0 TOTAL SCIENCE WT(Q1) 120.0
 FLIGHT ARTICLES (N1) 3.0 AERODECEL WT (P3) 81.0 PIXELS/LINE (TV)(Q3) 390.0
 NON-RTG POWER WT(W1) 55.0 TOTAL G/C WT (G1) 22.0 MIS DURATION(MD)(K1) 106.0
 RTG UNIT PER S/C(N2) 2.0 G/C RADAR WT (G2) 0.0 ENCOU TIME (MD) (K2) 4.0
 RTG FUEL LOADINGS(L1) 2200.0 RADIO COMM. WT (C1) 53.0 NO. ENC START UP(K3) 4.0
 TOTAL STRUCT. WT(S1) 294.0 DATA HANDLING WT(C2) 25.0 NO. SCI. TEAMS (K4) 6.0
 MECHANISMS/LG WT(S2) 31.0

INHERITANCE % STR PROP G/C COMM POW SCI
 EXACT REPEAT OF SUBSYS 15% 0% 35% 25% 60% 10%
 MINOR MODIFICATION OF SUBSYS 50% 50% 35% 25% 35% 50%
 MAJOR MODIFICATION OF SUBSYS 25% 50% 30% 25% 5% 25%

SUBSYSTEM CATEGORIES COST DIRECT LABOR NON-RECURRING RECURRING
 (MILLIONS) (000 HRS) (000 HRS) (000 HRS)
 STRUCTURE NORM INHER NORM INHER NORM INHER NORM INHER
 15.1 12.3 590 480 444 347 145 134
 AERODECELERATION 9.5 8.5 337 303 233 210 103 93
 GUIDANCE AND CONTROL 6.6 4.7 234 167 166 108 69 60
 COMMUNICATIONS 27.4 22.0 1130 907 734 551 396 357
 POWER 2.8 1.6 124 72 85 38 38 33
 SCIENCE INSTRUMENTS 20.6 17.8 754 653 441 362 314 292

SUBTOTAL 81.9 66.9 3169 2583 2104 1615 1066 968

SUPPORT CATEGORIES
 PROGRAM MANAGEMENT 5.8 4.9 230 195
 SYSTEMS ANALYSIS/ENG. 2.3 1.3 89 51
 TEST + QUALITY ASSURANCE 13.4 11.3 552 468
 ASSEMBLY AND INTEGRATION 2.7 2.0 110 81
 LAUNCH AND FLIGHT OPS. 89.1 89.1 2988 2988
 GROUND EQUIPMENT 5.6 4.5 187 149
 DATA ANALYSIS 33.0 33.0 1107 1107

SUBTOTAL 151.9 146.1 5263 5039
 TOTAL (WITHOUT RTG) 233.8 213.1 8433 7622
 RTG COST = 8.8

TOTAL 242.5 221.8 ADDL. FLIGHT UNIT = 30.0

 FISCAL YEAR 1980 1981 1982 1983 1984 1985 1986 1987 1988 1989 1990 1991
 NORMAL 10.9 37.3 32.1 27.5 10.6 3.5 1.1 25.6 29.1 9.0 31.8 6.0
 COMPRESSED 0.0 38.7 41.6 30.6 9.9 1.1 1.1 25.6 29.1 9.0 31.8 6.0

LABOR AND COST ESTIMATION RESULTS

PROJECT NAME MARINER VENUS/MERCURY RUN DATE FEB. 14, 1975
 PROJECT DESCRIPTION WEIGHT UNITS(POUNDS), POWER UNITS(WATTS)
 LAUNCH DATE (Z\$) 10/1973 MECHANISMS/LG WT(S2) 98.0 TOTAL SCIENCE WT(Q1) 168.0
 FISCAL WAGE DATE(D2) 1975.0 TC PYRO.CABL.WT (S3) 127.0 PIXELS/LINE (TV)(Q3) 832.0
 FLIGHT ARTICLES (N1) 1.0 PROF. SYS DRY WT (P1) 28.0 MIS DURATION(MD)(K1) 6.0
 NON-RTG POWER WT(W1) 152.0 TOTAL G/C WT (G1) 92.0 ENCOU TIME (MO) (K2) 3.0
 RTG UNIT PER S/C(N2) 0.0 RADIO COMM. WT (C1) 76.0 NO. ENC START UP(K3) 2.0
 RTG FUEL LOADING(L1) 0.0 DATA HANDLING WT(C2) 61.0 NO. SCI. TEAMS (K4) 5.0
 TOTAL STRUCT. WT(S1) 445.0 ANTENNA WT (C3) 8.0

INHERITANCE % STR PROP G/C COMM POW SCI
 EXACT REPEAT OF SUBSYS 0% 50% 50% 75% 25% 20%
 MINOR MODIFICATION OF SUBSYS 50% 50% 25% 50% 75% 70%
 MAJOR MODIFICATION OF SUBSYS 0% 20% 20% 10% 25% 0%

 COST DIRECT LABOR NON-RECURRING RECURRING
 (MILLIONS) (000 HRS) (000 HRS) (000 HRS)
 SUBSYSTEM CATEGORIES NORM INHER NORM INHER NORM INHER NORM INHER
 STRUCTURE 16.5 15.0 645 587 582 523 63 63
 PROFULSION 3.7 2.0 131 72 114 57 17 15
 GUIDANCE AND CONTROL 14.9 8.7 530 311 466 256 64 55
 COMMUNICATIONS 28.5 10.8 1174 447 995 298 179 149
 POWER 6.5 4.4 287 196 250 162 37 34
 SCIENCE INSTRUMENTS 18.9 14.1 692 519 559 392 133 127
 SUBTOTAL 88.8 55.1 3459 2132 2965 1689 494 443

SUPPORT CATEGORIES PROGRAM MANAGEMENT 6.3 4.4 250 172
 SYSTEMS ANALYSIS/ENG. 2.9 0.8 114 30
 TEST + QUALITY ASSURANCE 14.5 10.0 599 412
 ASSEMBLY AND INTEGRATION 3.1 1.5 125 61
 LAUNCH AND FLIGHT OPS. 25.6 25.6 858 858
 GROUND EQUIPMENT 7.4 3.8 247 128
 DATA ANALYSIS 12.6 12.6 421 421
 SUBTOTAL 72.4 58.6 2614 2082

 TOTAL (WITHOUT RTG) 161.2 113.7 6073 4214 RTG COST = 0.0
 TOTAL 161.2 113.7
 ADDL. FLIGHT UNIT = 23.9

 FISCAL YEAR 1971 1972 1973 1974 1975 1976 1977 1978 1979 1980 1981 1982
 NORMAL 18.2 41.6 36.0 42.4 12.8 6.6 3.5 0.0 0.0 0.0 0.0
 COMPRESSED 3.2 48.2 45.5 44.8 11.0 5.0 3.5 0.0 0.0 0.0 0.0

 TOTAL (WITHOUT RTG) 161.2 113.7 6073 4214 RTG COST = 0.0
 TOTAL 161.2 113.7
 ADDL. FLIGHT UNIT = 23.9

 FISCAL YEAR 1971 1972 1973 1974 1975 1976 1977 1978 1979 1980 1981 1982
 NORMAL 18.2 41.6 36.0 42.4 12.8 6.6 3.5 0.0 0.0 0.0 0.0
 COMPRESSED 3.2 48.2 45.5 44.8 11.0 5.0 3.5 0.0 0.0 0.0 0.0

 TOTAL (WITHOUT RTG) 161.2 113.7 6073 4214 RTG COST = 0.0
 TOTAL 161.2 113.7
 ADDL. FLIGHT UNIT = 23.9

 FISCAL YEAR 1971 1972 1973 1974 1975 1976 1977 1978 1979 1980 1981 1982
 NORMAL 18.2 41.6 36.0 42.4 12.8 6.6 3.5 0.0 0.0 0.0 0.0
 COMPRESSED 3.2 48.2 45.5 44.8 11.0 5.0 3.5 0.0 0.0 0.0 0.0

Cost Estimate for 1985 MSSR Mission

The model has been applied to a conceptual Mars Surface Sample Return mission launched in 1984. A summary of the cost estimates for this MSSR mission are presented on the following page. Using Mars Orbit Rendezvous a small soil return sample, 1-5 kg., is assumed with a total mission duration of nearly 3 years. Total weight at launch is 10,585 lbs.

Although our modeling data base does not include a sample return mission or a specific methodology for evaluating a sample return mission, it seemed reasonable to apply the model separately to each of the five major spacecraft modules. In particular, the design concepts of the Mars Orbiter Vehicle are patterned after Mariner, those of the Mars Lander after Viking, and those of the Earth Return Vehicle after INTELSAT. Total project cost in FY75 dollars is estimated as \$688.2M without inheritance or \$671.9M with inheritance from the above mentioned historical projects. Note that these estimates do not include any cost contingency, or special handling facilities of the returned sample. An additional flight article is estimated to cost \$74M.

Cost Estimate Summary for 1985 MSSR Mission

(2 Flight Articles \$Mils FY75)

	<u>No Inheritance</u>	<u>Inheritance</u>
Program Management & Integration	66.0	61.9
Spacecraft	537.3	525.1
Mars Orbiter Vehicle	201.8	196.2
Mars Lander	239.3	234.2
Mars Ascent Vehicle	30.0	29.6
Earth Return Vehicle	50.9	50.0
Earth Entry Capsule	15.3	15.1
Science ⁽¹⁾	42.1	42.1
Data Analysis ⁽²⁾	5.6	5.6
Ground Eg & Launch/ Flight Ops	37.2	37.2
Total Project Cost ⁽³⁾	688.2	671.9

(1) Sample acquisition science only

(2) Does not include extensive post-mission sample analysis

(3) Does not include contingency, launch vehicle, NASA management or contractor fee

MODEL APPLICATION SUMMARY RESULTS

Cost estimates are summarized in the table for several diverse projects not included in the model data base. The Pioneer (A-E) and ATS (A-E) projects were selected as examples which were thought to represent a significant extrapolation test of the model. Results obtained are quite encouraging in that the model estimates are within 5% of the actual project costs.

Model Application to Other Project Cost Estimates

Summary Results

<u>Project</u>	<u>FY\$</u>	<u>SAI Model*(\$M)</u>	<u>Comparison* (\$M)</u>	<u>Difference</u> %
Pioneer A-E	1965	55.8	58.7 (actual)	- 4.9%
ATS (A-E)	1966	133.1	137.3 (actual)	- 3.1%
MVM-73	1972	93.5**	98.0 (actual)	- 4.6%
MJS-77	1975	232.1	274.4 Estimate Cost to Complete	-15.4%

MSSR (Conceptual)	1975	688.2	741.0***	- 7.1%
Venus Radar Mapper	1975	174.3**	200.1***	-12.9%
Mariner Jupiter Orbiter	1975	241.9**	282.0***	-14.2%
Pioneer Saturn/Uranus Flyby (With Saturn 10 Bar Probe)	1975	221.8**	217.4***	+ 2.0%

*Excluding Contractor Fee, NASA Mgmt. and Contingency

**With Inheritance

***NASA Study Estimates Adjusted to FY 1975 Dollars

APPENDIX

SPACECRAFT CATEGORIES

FINANCIAL CATEGORIES

The following pages present a sample list of spacecraft and financial categories with an accompanying sample list of prime and subcontractors, all of which were used in this analysis.

Sample List of S/C Categories

Planetary Expl. Film
T.V. Results Film
Project Management
Project Scientist
Mars Atlas
Mission Analysis & Eng.
Mission Design & Analysis
Launch Vehicle Config.
Flight Path Prog. Dev.
Reliability Assurance Rep.
Div. Rep. - Div. 31
Div. 32 - Proj. Adm.
Div. 33 - Proj. Rep.
Div. 34 - Proj. Rep.
Environmental Sci. Div. Rep.
10 ft. and 25 ft. Space Simulators Maint.
25 ft. Simulator Design Const. & Liaison
Environmental Testing - Induced
Environmental Testing - Natural
Flt. System Support - Ground Test
S/C System Environment - EMI
S/C System Environment - PER
S/C System Environment - ERS
S/C System Environment - NSE
Systems Test Equipment
Test Facilities and Requirements
Flight S/C Test
Experiment Test Laboratory
Test Facility and Requirements Supp.
Decontamination Investigation
Support Equipment Cabling
System Instrumentation
Flight Data System SE. Sys. Ops.
Ground Data Handling Ops.
Flight Data System SE ETR Ops.
Flight Data System S E
Flight Data System S E Hdw. Contr.
ACS Artic S E Mission Ops.
ACS & Artic S E Sys. Ops.
CCS - OSE
Att-Artic Cont. Supp. Eq. Hrd.
Att Artic SE Cont.
Command SE
Power SE Sys. Ops.
Power ETR SE Ops.
Power SE

Computer Programming
Trajectory Design and Selection
Midcourse Maneuver & Terminal Maneuver
Analysis & Operations
Orbit Determination
Space Flight Operations Support
Television Systems & Project Engineering
Systems Engineering - Project Eng.
Reliability Test Planning and Support
Preferred Component Parts & Materials
Systems Engineering
Miscellaneous
Flt. G S/C Assy & Test
Launch Vehicle Compatibility Test
Subproject Management
System Planning Procedures
Structural Model Assy & Test
Eng. Model Assy & Test
Prototype S/C Assy & Test
EGSE Software Design & Dev.
Flt. F S/C Assy & Test
Electronic Parts Failure Analysis
Electronic Parts Control
Backup Parts Acquisition
Reliability
S/C QA Rep.
Quality Assurance
Microcirc. Selec. Quality & Design Lia.
Proj. Environmental Requirments
Natural Space Environments
Environmental Requirements Supp.
Electromagnetic Compatibility
Clean & Planetary Quarantine
Failure Reporting
F C Backup
Electronic Preferred Parts List
Spacecraft Analysis
Vehicle Design & Integration - Proj. Eng.
(Assembly & Int. Portion)
Structural and Dynamic Models
Flight Spacecraft Installation and Assembly

Ground Data Handling
Ground Data Handling Sys. Ops.
FDS Syst. Ops.
Ground Data Handling 516
Orbiter Sci. Anal. & Data Handling
Software Mgt.
V.O. Science Anal. Prog.
Command Team Mission Data
Flight Path Analysis-Mission Data
Mission and Test Video
Ground Data Handling (914)
Ground Data Handling-Mission Data
V.O. 75 IPL-Mission Data
GDA-Data Library-Mission Data
Science GDA-Mission Data
Telecom. Mission Data
Telecom. Mission Data
Power G & C Mission Data
Astrionics-Mission Data
Pyro & Prop Mission Data
Digital Telemetry Unit
Data Storage Unit
Digital Decoder Unit
Work Element Management
Digital Telemetry Unit
Digital Decoder Unit
Data Storage Unit Design
Data Storage Unit Product Design
Data Storage Unit
Major Procurement
Subproject Management
Ordnance
Subproject Engineering
Magnetometer Boom
RTG Structure
Equipment Compartment
Ordnance Devices
AML Support
Wobble Damper
Mil Hdlg & Pkg - Comm Subsystem
" " " - Antenna "
" " " - Data Hdlg S/S
" " " - ACS Subsystem

S/C Propulsion Manager
P & G Management
S/C Propulsion Procurements
RMD Vernier Engine Contract
Propulsion Div. Project Repres.
VPS Development
VPS Control Item
Propulsion Analysis Support
Retro Propellant Mech. Proper.
Retro Systems Analytical Supp.
Pyrotechnics Control
Command, Control & Sequencer
Surface Sampler Control Unit
Radar Altimeter
G & C Computer and Software
Inertial Reference Unit
Valve Drive Amplifiers
Terminal Descent Landing Radar
Engine Cut Off Sensors
Inverter Assembly
Test Support
Spares Conditioning
Inverter Assembly
Central TRF Unit
Test Equip. Procedures
Special Equipment
Manufacturing Support
Battery
Power Control Unit
Science Computer
Entry Science
Imagery
Biology
Molecular Analysis
Meterology
Free Bound Water (Closed)
Seismometer
UV Flux (Closed)
Inorganic Analysis
Etc.

Sample Financial Categories

Engineer and Scientist Salaries	Admin Computer Services Program
Administrative Salaries	Plant Engineering Design
Office and Clerical Wages	Plant Engineering Services
Technician and Other Wages	Fabrication Services
Adm. Administrative Salaries	Reproduction Multilith
Adm. Office and Clerical Wages	Reproduction Direct Print Process
Adm. Technician & Other Wages	Reproduction Internal Distr
Material Purchases	Photography
Material Transfers	Publications Periodicals
Operating Supplies	Publications Reports
Freight	Publications Graphics
Postage	Rental of Equipment - ADP
Reproduction Transfers	Rental of Equipment
Miscellaneous	Rental of Space
Instr-Repair-Calib-Loan Org 3719	Conference & Symposium Reg Fees
Eastern Test Range	Outside Professional Services
Electronic Parts	Outside Non-professional Services
Environ. Lab Liquid Nitrogen	Other Contract Services
Space Simulator	R & D Contract Services
ETS Instrumentation	Caltech Labor, WO & Matl Transfer
ETS Environmental Testing	Telephone & Telegraph Serv Charges
ETS Solid Propulsion	Toll and Message Charges
ETS Liquid Propulsion	Special Telephone Services
Computer Prog. Section 314	General Burden
Computer Prog. Section 315	Applied Project Staff Burden
Computer Digital Operations 314	Applied Technical Division Burden
Computer Analog Operations	Applied Admin. Services Burden
Chemistry Laboratory	Applied Laboratory Burden
Design	Equipment - Movable
Instr-Repair-Calib-Loan Org 3717	Equipment - Installed
Instr-Repair-Calib-Loan Org 3718	Equipment - Minor
Travel Local Transportation	Hand Tools
Domestic Travel Regular	Etc.
Domestic Travel Special	
Foreign Travel Regular	
Foreign Travel Special	

Sample List of Prime and Subcontractors

J. P. L.
T. R. W.
Martin
Hughes
Boeing
A. R. C.
Time Zero
G. S. F. C.
U. of California
U. of S. C.
U. of Arizona
SBRC
U. of Chicago
Gen. Electric
Philco
R. C. A.
Eastman Kodak
C. I. T.
U. of Iowa
Itek
Lockheed
Ryan
Honeywell
Electro-Optical
M. I. T.
Texas Instr.
Motorola
Resdel
CBS Labs
Nortronics
Battelle
P. R. C.
Astrodata
Stellarmetrics
Etc.