

General Disclaimer

One or more of the Following Statements may affect this Document

- This document has been reproduced from the best copy furnished by the organizational source. It is being released in the interest of making available as much information as possible.
- This document may contain data, which exceeds the sheet parameters. It was furnished in this condition by the organizational source and is the best copy available.
- This document may contain tone-on-tone or color graphs, charts and/or pictures, which have been reproduced in black and white.
- This document is paginated as submitted by the original source.
- Portions of this document are not fully legible due to the historical nature of some of the material. However, it is the best reproduction available from the original submission.

THE MINI-O, A DIGITAL SUPERHET, OR
A TRULY LOW-COST OMEGA NAVIGATION RECEIVER

RECEIVED
FEB 17 10 12 AM '76
OFFICE OF
UNIVERSITY AFFAIRS

by

R. W. Burhans
Avionics Engineering Center
Department of Electrical Engineering
Ohio University
Athens, Ohio 45701

(NASA-CR-144923) THE MINI-O, A DIGITAL
SUPERHET, OR A TRULY LOW-COST OMEGA
NAVIGATION RECEIVER (Ohio Univ.) 45 p
HC \$4.00 CSCL 17G

N76-17083

Unclas
13640
G3/04

November, 1975

FEB 1976
RECEIVED
NASA STI FACILITY
INPUT BRANCH

Supported by

National Aeronautics and Space Administration
Langley Research Center
Langley Field, Virginia
Grant NGR 36-009-017

ABSTRACT

A quartz tuning fork filter circuit and some unique CMOS clock logic methods provide a very simple OMEGA-VLF receiver with true hyperbolic station pair phase difference outputs. An experimental system has been implemented on a single battery-operated circuit board requiring only an external antenna preamplifier, and LOP output recorder. A bench evaluation and preliminary navigation tests indicate the technique is viable and can provide very low-cost OMEGA measurement systems. The method is promising for marine use with small boats in the present form, but might be implemented in conjunction with digital microprocessors for airborne navigation aids.

TABLE OF CONTENTS

	Page
I. INTRODUCTION	1
II. QUARTZ TUNING FORK FILTERS	1
III. 60 Hz NOISE PROBLEMS	6
IV. SIGNAL ENVELOPE	6
V. HOUSEKEEPING TIMER CIRCUITRY	9
VI. OMEGA CLOCK	9
VII. MIXER PHASE DETECTOR TECHNIQUE	9
VIII. OMEGA INTERMEDIATE SEQUENCY	10
IX. OMEGA 13.6 KHz CHANNEL INTERMEDIATE SEQUENCY	15
X. MICROPROCESSOR INTERFACE	16
XI. DIRECT RAW PHASE DIFFERENCING	16
XII. CLOCK OFFSET ERROR	18
XIII. BENCH AND FIELD TESTS	22
XIV. MULTIPLEXED DISPLAY FOR MARINE USE	30
XV. WEAK SIGNAL SENSITIVITY FOR RAW PHASE	30
XVI. OTHER APPLICATIONS	30
XVII. FUTURE	33
XVIII. ACKNOWLEDGEMENTS	33
XIX. REFERENCES	33
XX. APPENDIX	35

OHIO UNIVERSITY
COLLEGE OF ENGINEERING AND TECHNOLOGY
CLIPPINGER BUILDING
ATHENS, OHIO 45701

DEPARTMENT OF ELECTRICAL ENGINEERING

February 11, 1976

~~NASA Headquarters
University Affairs Office
400 Maryland Avenue, S.W.
Washington, D.C. 20546~~

RECEIVED
FEB 17 10 12 AM '76
UNIVERSITY AFFAIRS

Dear Sir:

Enclosed please find three copies of Technical Memorandum 20 (NASA CR-144923) entitled "The Mini-O, A Digital Superhet, or A Truly Low-Cost Omega Navigation Receiver."

If you have any questions or comments, please contact us.

Sincerely,

Richard H. McFarland
hm

Richard H. McFarland
Project Director
Avionics Engineering Center
614-594-5746

RHM:hm

Enclosures: 3

xc: Atchison
Rohrer
Scull
Senstad
Form

LIST OF FIGURES

	Page	
Figure 1.	10.2 KHz Receiver Front-End.	3
Figure 2.	Stable OMEGA 10.200 KHz Signal Source.	4
Figure 3.	Envelope Detector Characteristics.	5
Figure 4.	Receiver with Front-End Filter Housing.	7
Figure 5.	Typical OMEGA Signal Levels.	8
Figure 6.	Housekeeping Timer Circuit.	10
Figure 7.	OMEGA Chronometer Dial Plate.	11
Figure 8.	Buffer-Divider for External 2^{21} Hz Clock.	12
Figure 9.	Digital Mixer-Phase Detector.	14
Figure 10.	Microprocessor Interface.	17
Figure 11.	Operation of a 4 Bit LOP Display.	19
Figure 12.	4 Bit D/A LOP Display.	20
Figure 13.	Front Panel of OMEGA Receiver.	21
Figure 14.	Clock Offset Determination with a 4 Bit D/A.	23
Figure 15.	OMEGA Phase Subtraction with Large Clock Offset.	25
Figure 16.	Mobile Field Tests in VW Microbus.	26
Figure 17.	Lab Bench Evaluation of OMEGA Receiver.	27
Figure 18.	OMEGA Receiver Circuit Board.	28
Figure 19.	OMEGA Signal Source.	29
Figure 20.	5 Minute Multiplexing of Raw OMEGA Phase.	31
Figure 21.	Raw OMEGA Phase for Weak Signals.	32

	Page
Figure A-1. Test Flight Path.	37
Figure A-2. Signal Envelope During Test Flight.	38
Figure A-3. Test Flight Record, Approach and Landing.	39
Figure A-4. Test Flight, Down Leg and Return.	40

I. INTRODUCTION

In the early days of the NASA Tri-University Program, some suggestions were made on the design of a simple OMEGA navigation receiver using simultaneous pair methods. [1] A laboratory bench system was evaluated which lacked phase tracking sensitivity for the lowest level OMEGA signals. [2] This effort was abandoned in favor of a unique digital processing system using a memory aided phase-lock-loop (MAPPL) which proved very successful. [3] Technology breakthroughs have occurred since the early work which now makes it possible to provide a phase tracking receiver with very simple and low-cost digital sensor methods. The developments are miniature quartz tuning forks for very high Q RF front-end filters, and CMOS clock logic techniques which result in some unique simplifications in digital processing methods. A single channel receiver using a digital mixer station pair phase difference method, turns out to be even simpler than the original simultaneous pair measurement idea. [4]

II. QUARTZ TUNING FORK FILTERS

Miniature-size quartz resonators operating in the low frequency (10-100 KHz) range were developed in the early 1970's for the frequency determining element in digital clocks and wristwatches. Of particular interest are the STATEK oscillator crystals which are physically constructed like a tuning fork. [5] Hundreds of thousands of these crystals at 32.768 or 16.384 KHz have been made for watches which use CMOS binary chains dividing by 2^{15} or 2^{14} to provide one second time pulses. These tuning fork oscillators are somewhat more stable than older style X-cut low frequency crystals, and they can be accurately trimmed to the correct frequency by laser etching of micro weights attached to the tines of the tuning fork. Q's of 100,000 are easily obtained. The tuning fork crystals are vacuum sealed in a micro-sized package for hybrid fabrication methods in digital watches or they can be obtained in a TO-5 style of housing for conventional circuit board use.

It turns out that by punching a hole in the housing and filling the can with air (predominantly nitrogen) and then resealing, the Q can be reduced to the order of 2500. The nitrogen serves as a damper gas for the tuning fork tines. A Q of 100,000 is virtually impossible to use as an RF input bandpass filter because the bandwidth is much too narrow. However, a Q of 2500 provides a 3 db bandwidth of 4 Hz which is just on the edge of the narrowest possible bandwidth that can be used to track an OMEGA VLF signal with a typical one second on time for each channel. The 4 Hz filter bandwidth will allow the signal sufficient time to buildup, decay, and be observable in the output before the next station comes on. A narrower bandwidth filter will have the major difficulty of too much energy storage and the individual OMEGA signals will not be recognizable as such in the output or the ringing time of the filter will far exceed the on-time of the signal.

These low-frequency crystal units modified for lower Q use are inherently low-capacitance devices which require high input impedance circuitry for proper use. Conventional operational amplifiers of the LM301 variety may be used. A lower cost approach to amplifier design uses the CDA's (current differencing amplifiers) following a low-noise antenna preamplifier and medium Q active filter driving the single pole quartz tuning fork unit. A suitable circuit is shown in Figure 1 which uses a STATEK 10.204 KHz type SX-1N filter crystal. Here the preamplifier has been modified over those reported previously, [6] by using a low-cost audio transformer for some broad-band filtering directly at the preamplifier output and direct coupling of the antenna to the input JFET gate with a somewhat lower input resistor to reduce static charge problems.

The output of the preamplifier drives an active bandpass filter with a Q of 25 using the first two amplifiers of the quad LM3900. The combination of the input transformer filter and the active filter provide sufficient narrow band gain to drive the quartz filter even though the noise figure of the LM3900 CDA used is higher than for more conventional operational amplifiers. In a practical VLF receiver, just sufficient low-noise gain is required in the input stage to overcome the operational amplifier noise, and the atmospheric noise level is much larger than the op amp noise.

The performance of the crystal filter is very critically dependent on neutralizing the shunt capacitance and minimizing the circuit board layout capacitance. A "gimmick" type of neutralizing capacitor (C_n of Figure 1) of about 0.7 pf was required with a pair of insulated twisted wires about 5 mm long and a one turn twist over the last 2 mm or so. The crystal shunt capacitance neutralizing to the non-inverting input of the LM3900 improves the skirt selectivity of the filter and reduces the direct capacitance feed-through to -60 db except at the resonant frequency. A small additional reduction in output noise bandwidth is obtained by operating the final output amplifier also as a bandpass filter with a Q of 5. The STATEK crystal is cut for 10.204 KHz but provides a center frequency of 10.200 KHz in this filter circuit because the oscillator used in production test for automatic laser trimming to frequency has slightly different resonant properties than the filter circuit. In particular, the filter circuit probably has more layout capacitance due to the circuit board used.

The adjustment and lab bench checkout of these narrow band amplifier circuits requires a very stable but tunable signal source. A suitable source was fabricated from a 10.200 KHz Vernitron single pole ceramic filter unit with a Q of 100. The circuit for the test oscillator is shown in Figure 2.

The remaining portion of the RF front-end circuitry is the limiter and zero crossing comparator which are similar to the methods reported in the previous front-end design. [7] An additional simplification in this circuit is the use of only one gate indicator to provide automatic start on the strong OMEGA D channel in the North American region. This gate can also be used as a "quick look" noise level detector or noise blanker in the digital processing if desired. An adjustable threshold control on the gate comparator provides for setting the operating point to correspond with the limiter envelope detector range shown in Figure 3.

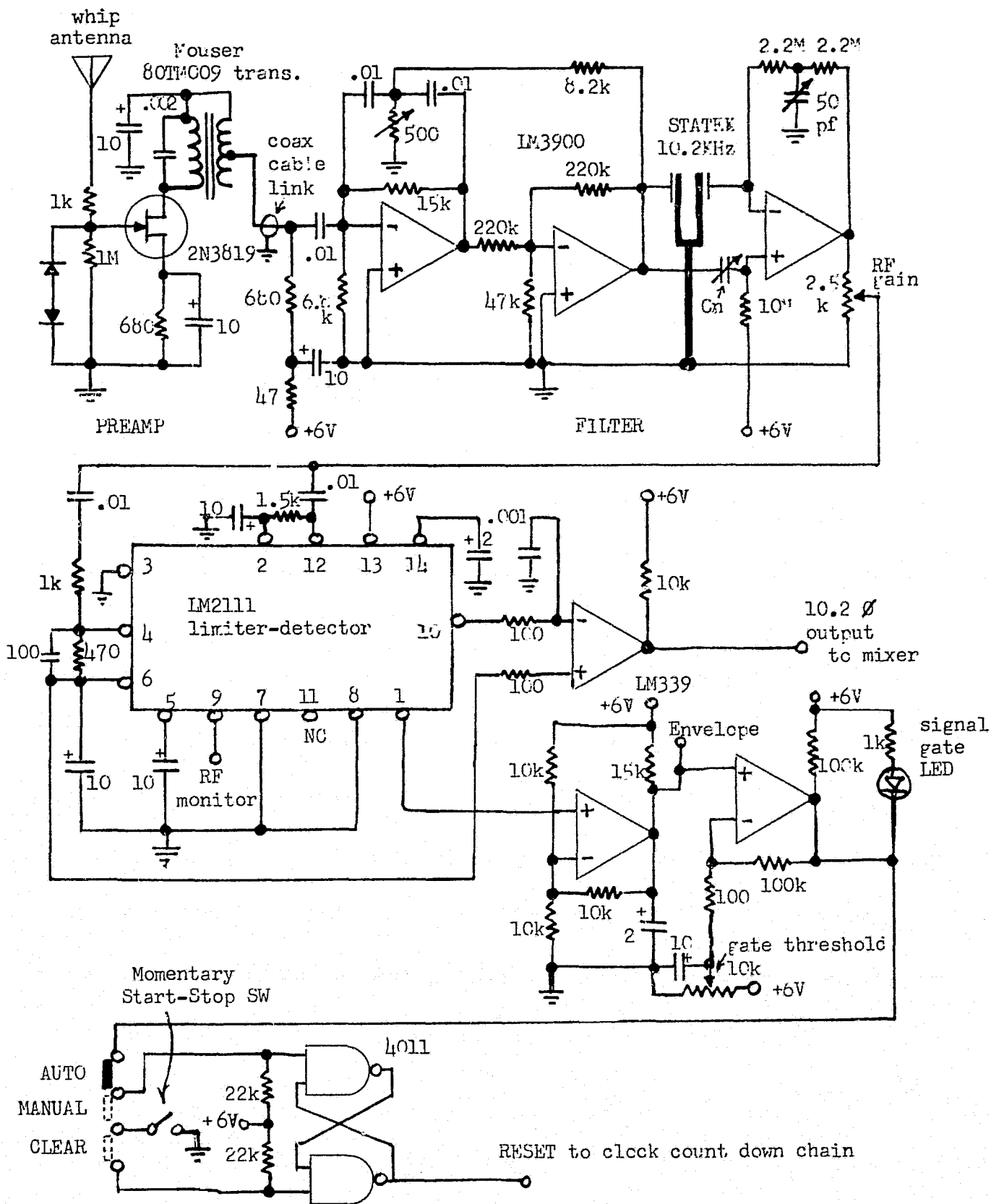

Figure 1. 10.2 KHz Receiver Front-End.

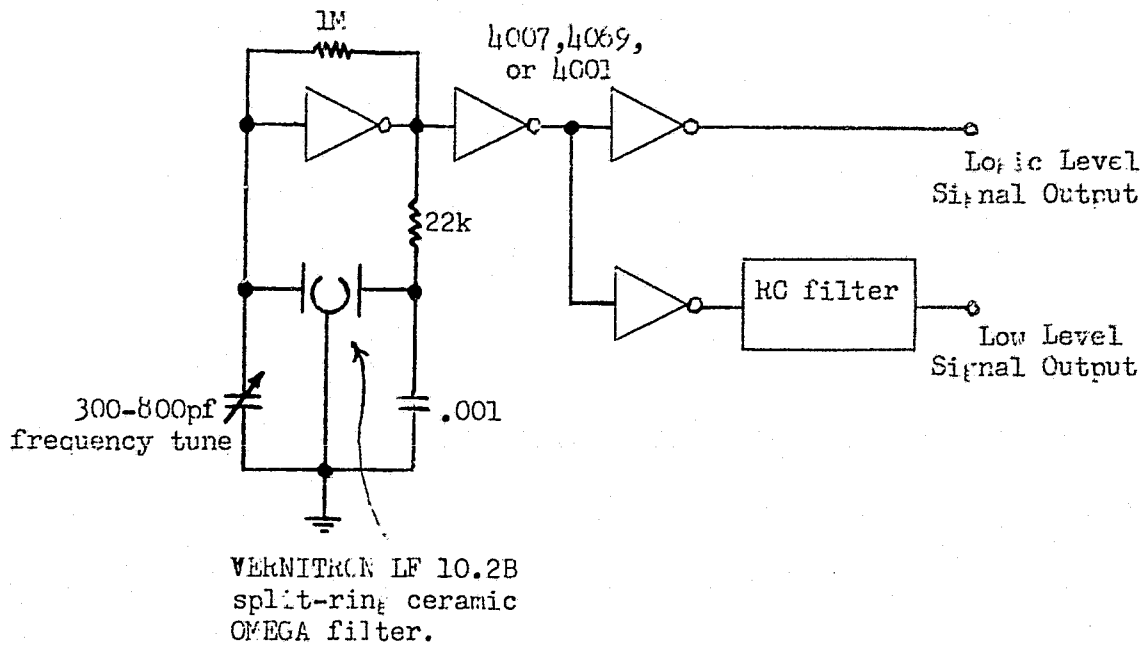

Figure 2. Stable OMEGA 10.200 KHz Signal Source.

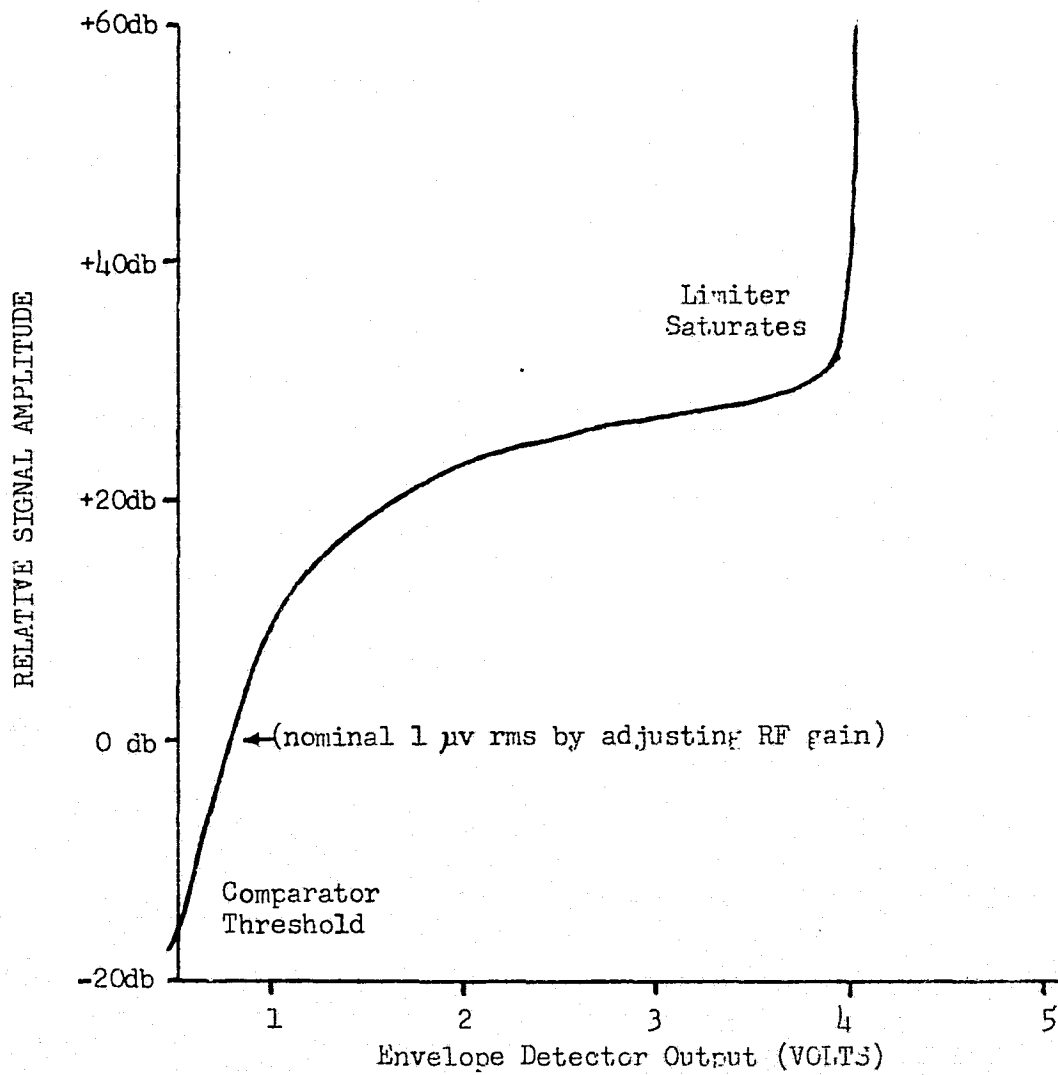

Figure 3. Envelope Detector Characteristics.

The circuit of Figure 1 will operate over the range of power supply voltages from +5 to +9V DC with the only change being a slight increase of the indicated dynamic range with the higher power supply voltages. (A widely varying power supply voltage will also affect the internal receiver clock stability, so some reasonably stable power source should be used if possible.)

This circuit provides an overall gain of 120 db ahead of the zero crossing comparator. The preamplifier is intended to be connected to a whip or wire antenna with an effective length of 1 meter or so when driving the 1 megohm input resistor of the JFET. The sensitivity of less than 1 μ v rms at the input and a 60 db or more dynamic range are adequate for most OMEGA VLF uses.

This ultra narrow band filter-limiter is mounted in a cast aluminum shield box at the rear left of the circuit board as shown in the photograph of Figure 4. The antenna preamplifier is connected to the front-end through a suitable length of coaxial cable.

III. 60 Hz NOISE PROBLEMS

A problem in many ground installations for OMEGA monitoring is 60 Hz interference which results in direct radiation of a 10.2 KHz signal (the 170th harmonic of 60 Hz) due to arcing electric motor brushes or other noisy electrical devices. This is most severe right at ground level and can sometimes be reduced by raising the tip of the whip antenna just above the local tree-top levels. In a marine, aircraft, or backpacking installation, 60 Hz interference is usually not a problem. However, it is always wise to have the antenna clear of the immediate terrain, a 30 meter or so horizontal distance away from tall trees, hanging cliffs, or buildings.

IV. SIGNAL ENVELOPE

A recording of the envelope amplitude level taken at 1 AM when interfering 60 Hz noise was at a minimum is shown in Figure 5. This was recorded from a 1 meter whip antenna which was mounted below tree-top level, literally stuck out the attic window of a three story house, providing a relatively low effective height of 15 cm or so. The recording clearly showed the B, C, and strong D OMEGA signal amplitudes. This type of recording of signal amplitude is not usually possible with a 30 Hz or 100 Hz conventional VLF front-end which will only indicate the strong D channel under the same conditions. Thus, the 4 Hz ultra narrow band amplifier-limiter provides a considerable improvement in that the raw OMEGA signal prior to any phase processing can be observed in the RF front-end, even for the weakest B channel OMEGA signal in this case, and there is sufficient amplitude separation to distinguish one signal from another. Some of the amplitude response is limited here by the recorder used which had a 0.1 second/inch penmotor response time.

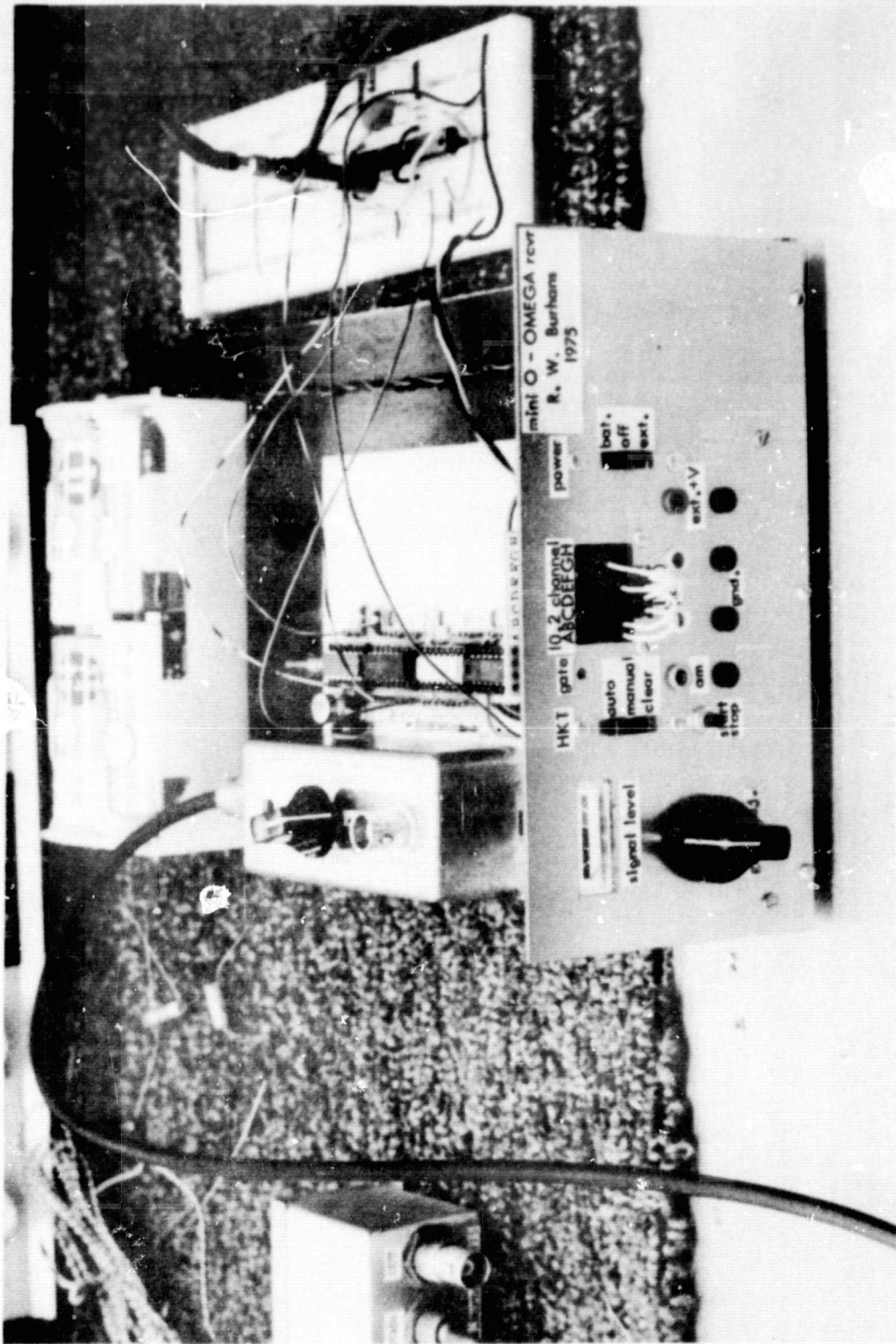
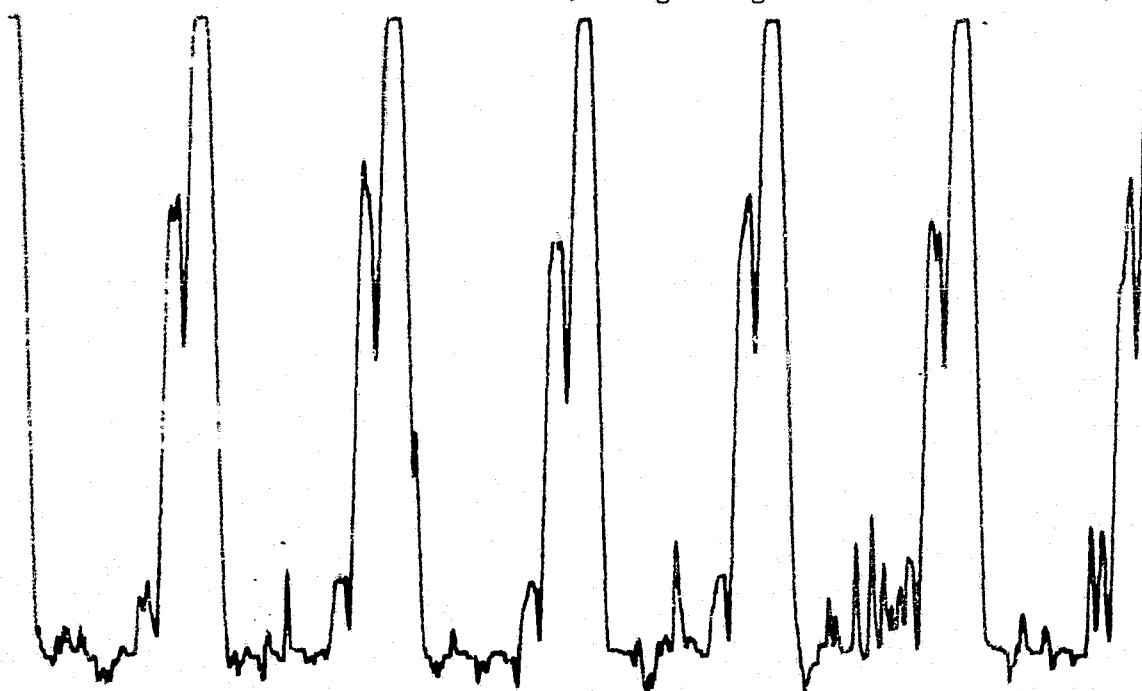

Figure 4. Receiver with Front-End Filter Housing.

ORIGINAL PAGE IS
OF POOR QUALITY

ULTRA NARROW BAND FRONT-END
(10.2kHz Envelope in 4Hz BW)

(Strong D signal saturates limiter)



station D F H A B C D
└ 10 seconds ┘

TIME: 0100 Hrs EDT, OCTOBER 8, 1975

Figure 5. Typical OMEGA Signal Levels.

V. HOUSEKEEPING TIMER CIRCUITRY

A similar advance in technology in the CMOS logic packages now available provides minimal chip timing functions for the OMEGA sequence directly from a binary clock frequency of 16.384 KHz (2^{14} Hz). The circuit is shown in Figure 6. A standard STATEK watch crystal is used in one version with a CD 4007 oscillator. The 4040 provides binary references for phase processing, the 4017 provides ten control gate positions within each time slot, and the 4022 generates 8 separate time slots to complete the OMEGA sequence. The strong D channel is used to reset the whole countdown chain with a selector switch option for manual start and clear from the receiver front panel. LED indicators tell the operator where the OMEGA sequence is, and a single gate LED operated from the comparator of Figure 1, provides an indication when the strong D channel saturates the limiter.

VI. OMEGA CLOCK

A refinement in OMEGA navigation hardware uses a CD 4045 CMOS or similar chip which starts out at 2^{21} Hz (2.097152 MHz) and counts all the way down to a 2 Hz pulse motor clock manufactured by General Time Corporation as their GT-500 quartz replacement clock movement. The clock will run on 2C cells for some 385 days continuously. A clock dial calibrated in approximate OMEGA seconds (1.25 second intervals), Figure 7, provides an easy way of telling where the OMEGA sequence is even when the receiver is off once the GT-500 movement has been properly set. Omega time is about 4 seconds earlier for channel A start than UTC zero, or channel D starts at about UTC zero for North American users. The 2^{21} Hz clock can be used by the marine operator not only as a standard celestial navigation chronometer for determining longitude, but also as an OMEGA clock to determine when to manually start the OMEGA receiver sequence even if the OMEGA signal has some strong local interference preventing a reliable automatic startup on the D signal.

The same 2^{21} Hz clock system when provided with an auxiliary buffer and 7 stage divider, Figure 8, generates the 16.384 KHz reference for the HKT circuit of Figure 6. Thus, the crystal used in Figure 6 can be removed and the output of the clock buffer divider of Figure 8 substituted as a common Time-Frequency reference for the navigation system.

VII. MIXER PHASE DETECTOR TECHNIQUE

Virtually all previous OMEGA VLF receivers use a much higher reference frequency than 16.384 KHz for phase processing such as $2^8 \times 10200$ or 2.6112 MHz. The reason for this is that the usual phase detector method involves phase-locking the OMEGA 10200 zero crossings with the clock requiring many choices of possible clock positions to resolve the phase to 2^8 parts per cycle. There is another method which is often used in frequency counters and frequency synthesizers. [8] A

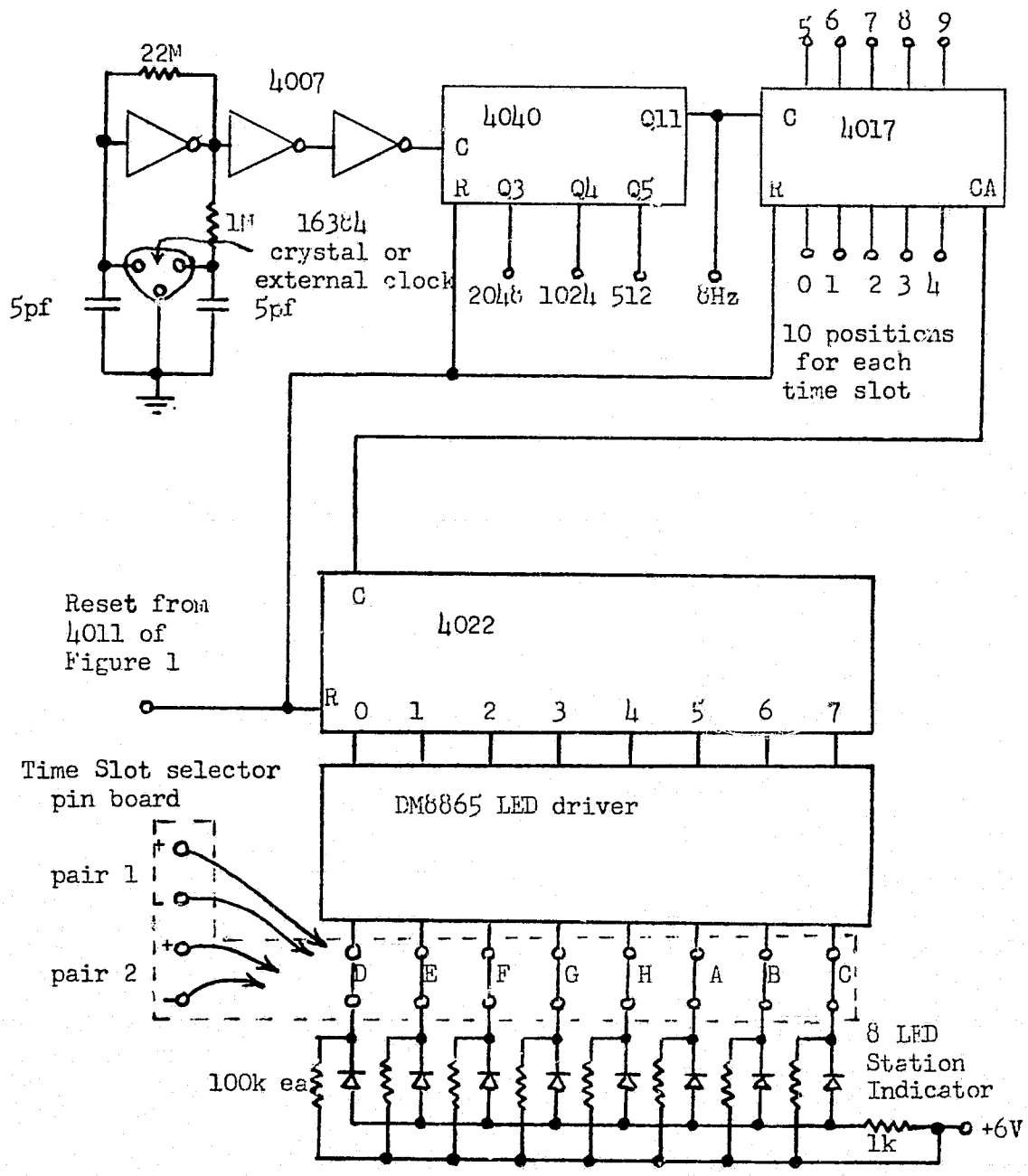

Figure 6. Housekeeping Timer Circuit.

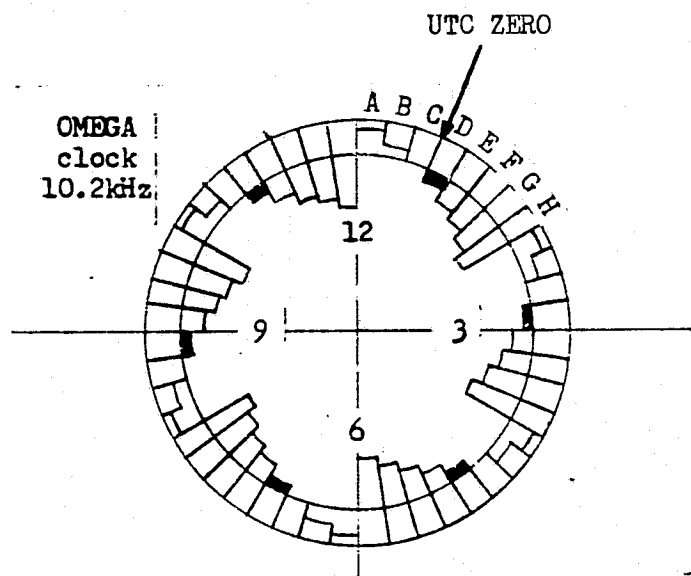

Figure 7. OMEGA Chronometer Dial Plate.

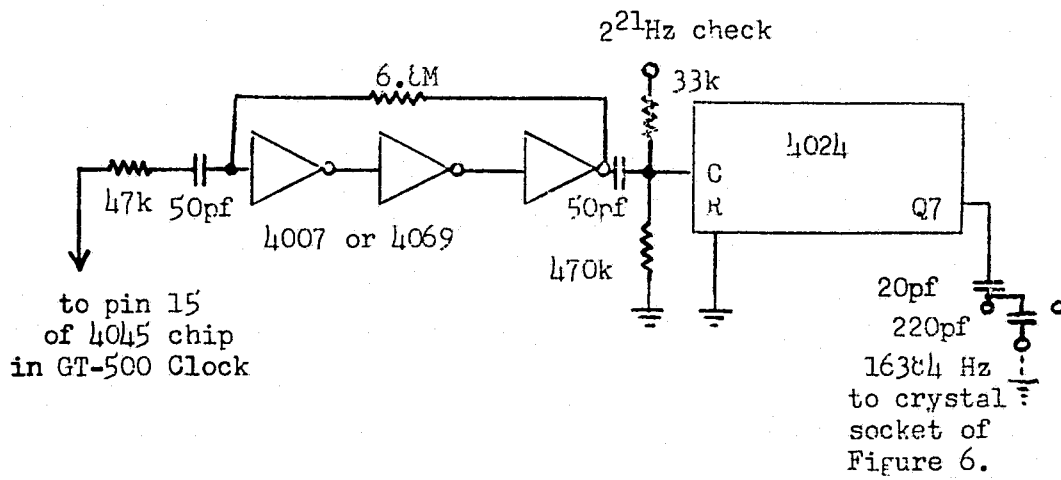

Figure 8. Buffer-Divider for External 2²¹ Hz Clock.

superheterodyne principle involving a true mixer (two quadrant multiplier) has the property of converting the input frequency to a lower coherent frequency providing that the local oscillator has the requisite frequency stability. A frequency tolerance of $\pm 5 \times 10^{-6}$ is just barely sufficient to generate differences that are less than 10 seconds apart, or such a local clock will be off by less than a cycle during the OMEGA sequence sample and hold operations. The STATEK crystals are about this good, and the General Time quartz clocks can provide somewhat better precision.

If the OMEGA signal zero crossings are fed to the D input of a type D flip-flop and a suitable binary reference frequency used as the clock, a sequency* is generated wherein the OMEGA signal is now converted to samples of the local clock interval. In analog RF methods we would call the clock the local oscillator, and the mixer output the IF (intermediate frequency). In digital systems the output Q or \bar{Q} from the D flip-flop is an intermediate sequency (IS) where the number of zero crossings per second (Zps) is related to the analog case but has a variable duty cycle pulse width modulation.

VIII. OMEGA INTERMEDIATE SEQUENCY

A brief analysis of the OMEGA 10200 Hz case follows:

	<u>Signal</u>	<u>LO</u>	<u>IS</u>
(1) 1st stage mixer	10200 Hz	- 8192 Hz	= 2008 Zps
(2) 2nd stage mixer	2008 Zps	- 2048 Hz	= (-) 40 Zps
(3) 3rd stage mixer	40 Zps	- 32 Hz	= 8 Zps

We have now converted the OMEGA zero crossings to an 8 Zps intermediate sequency which can be compared in phase with respect to an 8 Hz frequency generated from the same binary reference clock:

(4) 1st LO	16384/2 =	8192 Hz
(5) 2nd LO	8192/4 =	2048 Hz
(6) 3rd LO	2048/64 =	32 Hz
(7) Reference	32/4 =	8 Hz

All of these references are obtained from a single 4040 chip driven by the 16384 Hz clock oscillator as in Figure 6.

It turns out that the 8 Zps signal obtained from (3) is inconvenient to measure with respect to an 8 Hz square wave. The problem can be greatly simplified by using a single D flip-flop with a 2048 Hz LO and an RS flip-flop triggered respectively by turning on with the 8 Hz reference and always turning off with the next 40 Zps signal. The logic required here, which may not be immediately obvious, is shown in Figure 9.

* Sequency, as used here, is defined as the average number of zero crossings per second.

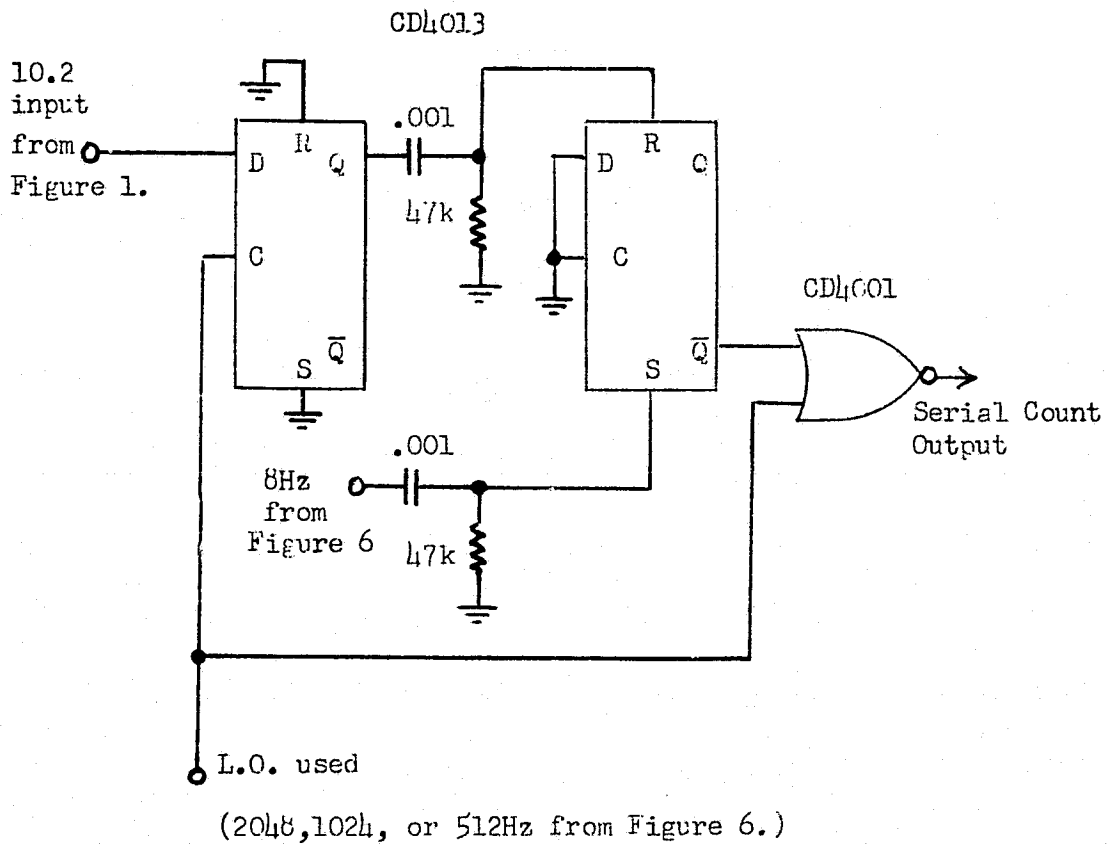

Figure 9. Digital Mixer-Phase Detector.

The Q output of the D flip-flop of Figure 9 is a complex window whose width is proportional to the phase difference between the 10200 Hz signal and the 2048 Hz local oscillator. There will be 51.2 edges of the 2048 reference frequency in a full cycle change of the 10200 Hz signal if we sample at an 8 Hz rate:

$$(8) \quad 2048/40 = 51.2 \text{ edges, per 8 Hz sample}$$

The other half of the 4013 dual D flip-flop of Figure 9 is used as the RS flip-flop. The Q output of the RS stage is the window desired and the NOR gate fills the interval with the allowed number of 2048 pulse as per (8) which can never be greater than 52 or less than 1 in practice. Thus, a variable pulse train is created where the number of pulses is proportional to the phase difference between the local clock and the OMEGA signal, and the resolution is:

$$(9) \quad 52 - 1 = 51 \text{ pulses/cycle}$$

This corresponds to 2 centicycles in the usual OMEGA designation of 1 cycle = 100 centicycles. Correspondingly lower resolution, but with greater filtering for noisy OMEGA zero crossings, can be obtained by using a lower LO as the clock input to the type D mixer:

$$(10) \quad 1024/40 = 25.6 \text{ edges, per 8 Hz sample}$$

$$(11) \quad 512/40 = 12.8 \text{ edges, per 8 Hz sample}$$

If we use exactly 5 of the 8 Hz rate samples for each OMEGA time slot measurement, then a binary count can be obtained for a one cycle change in OMEGA phase:

$$(12) \quad 52.1 \times 5 = 256, (2^8)$$

$$(13) \quad 25.6 \times 5 = 128, (2^7)$$

$$(14) \quad 12.8 \times 5 = 64, (2^6)$$

Thus, a direct binary number estimate of the phase difference between the local clock and the OMEGA signal can be generated with the proper 8 Hz gating. We have now converted the OMEGA serial input data to parallel binary numbers in terms of the Q outputs of binary counters for 8, 7, or 6 bit lengths after a 5 cycle of 8 Hz measurement interval. This binary information may be subtracted to generate a line-of-position (LOP) for conventional hyperbolic navigation directly from the raw counter output, or the parallel data may be used as input to an 8 bit microprocessor for more sophisticated software loop processing. The phase measurement precision will only be within 2 centilanes even though we have generated an 8 bit estimate of the phase value between 1 and 52 in this case.

IX. OMEGA 13.6 KHZ CHANNEL INTERMEDIATE SEQUENCY

It is also possible to generate an intermediate sefrequency for the 13.6 KHz OMEGA channel from a binary clock starting at 2^{14} Hz. The method involves, in

principle, a 5 stage mixer starting with a 1st LO of 16384 Hz and a final comparison frequency of 32 Hz. This has not been implemented in hardware but should turn out quite similar to the 10.2 KHz system.

All of these digital mixing schemes may use direct or harmonic mixing where the IS may be either the difference between the D input signal and the LO or the difference between the D input and the Nth harmonic of the LO. In these OMEGA cases an "Upconverter" is involved such that the LO is effectively on the high side of the signal which has the effect of reversing the phase change of the final output. In practical use this is of little consequence, since a meter scale can be arranged to read either direction for the proper centilane designation or inverters at the output of the counting flip-flops may be used to display the output always as an increase in count for an increase in centilane number.

X. MICROPROCESSOR INTERFACE

An interface consisting of the mixer-phase detector of Figure 9, a 4520 dual binary up-counter, and control gating is shown in Figure 10. The HKT selectors of Figure 6 can be used to identify which combinations of stations are being serially fed to the counter as the OMEGA sequence proceeds. Another RS flip-flop generates 5 cycles of the 8 Hz signal by turning on with the 1 reference time from the 4017 decoder and turning off with the 6 reference time. The 0 time position of the 10 pulses for each OMEGA time slot is used to clear the counter and the 7, 3, or 9 position can be used to indicate the time to read the output of the 4520 counter or as an interrupt for the microprocessor. Thus for each OMEGA time slot a word enable command is generated which will allow entry of the parallel data from the Q outputs of 4520 into the microprocessor with the 0 time pulse clearing the counter for each new measurement.

In practice the microprocessor software designer uses this data in a number of different ways. Subtraction of selected pairs with mean, median 3, or simpler averaging programs can be used to generate LOP's. Software loops, which accumulate the clock drift error by comparison of station data from the same station 10 seconds later, followed by differencing among stations, is another approach and more sophisticated software limited mostly by the imagination of the programmer. Since the local clock will always be drifting one way or another with respect to the OMEGA signal, even when the receiver is not moving, some sort of subtraction during a 10 second total OMEGA time sequence is required in the microprocessor. Truly sophisticated methods will also involve application of diurnal corrections to the LOP's generated from mathematical models and the appropriate time of day information which could be directly entered from the same clock using somewhat more complex digital hardware in the HKT circuit.

XI. DIRECT RAW PHASE DIFFERENCING

The simplest possible OMEGA LOP measurement involves taking the difference of sequential station pairs such as B-C or C-D in less than one OMEGA

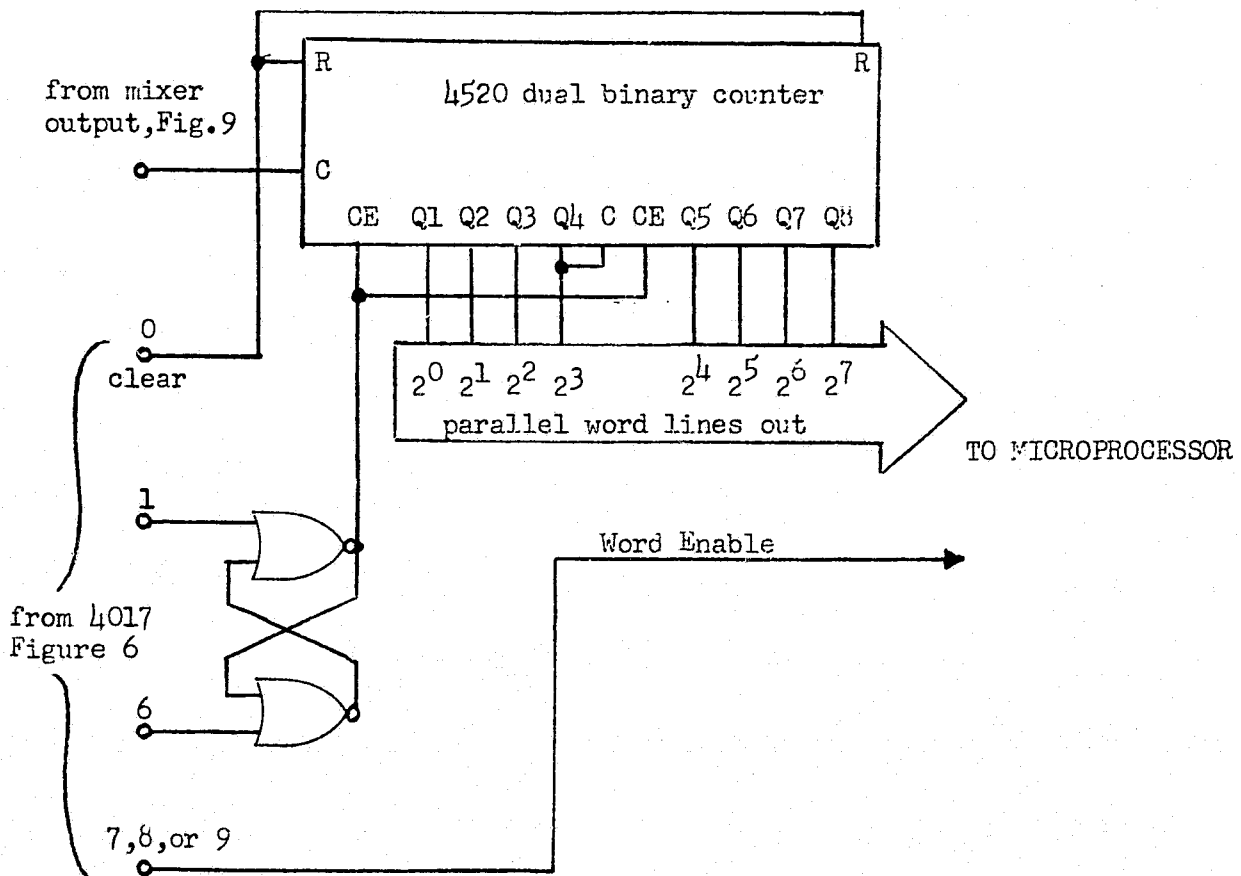
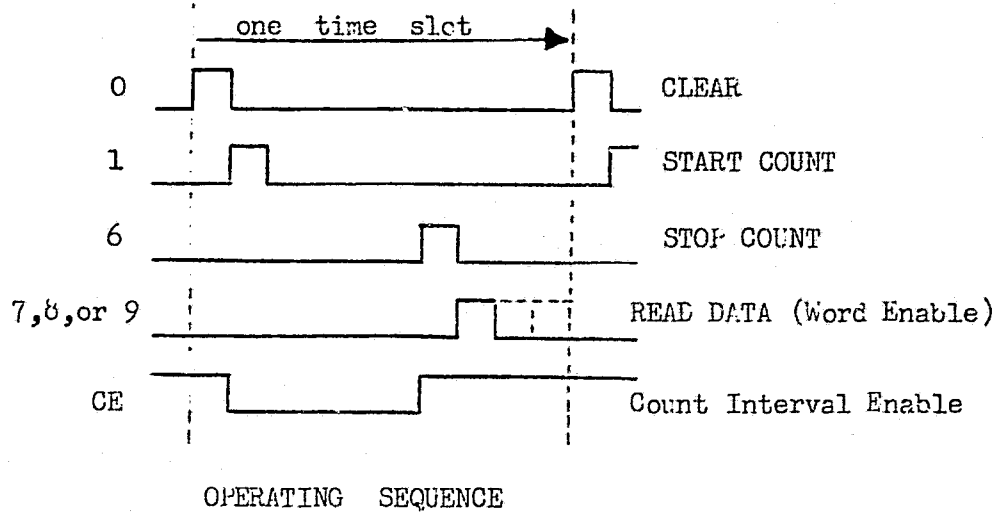

Figure 10. Microprocessor Interface.

10 second sequence. This method, which we call single time slot OMEGA phase or RAW OMEGA PHASE, will not provide useful navigation information with a front-end bandwidth of 30 to 100 Hz. However, with the 4 Hz ultra narrow band filter and the additional filtering provided by the mixer-phase detector, a single time slot method is possible. The technique involves using an up/down counter, first clearing the counter to all zeros, count-up during the first station selected, hold count, count-down during the second station selected, hold count, read, and finally clear to all zeros again and start over at the next 10 second sequence. For a typical C-D case, the sequence of operations is shown in Figure 11.

A 4 bit D/A for display of the raw phase data to a pointer reading indicator or pen recorder is illustrated in Figure 12. The D/A has a 1 second RC filter with no blanking so that the clock drift error may be estimated. The trend of the phase difference C-D can be easily seen during the longer read interval time of Figure 11.

A simple implementation of a navigation receiver suitable for marine use would involve this circuit and the use of a dual channel strip chart recorder. The display bobble of Figure 11, due to not blanking the up/down count time, can be reduced by using a latch for each LOP and programming the latch to write after the #6 time pulse of the 2nd station, or after the D channel for the case C-D.

It is interesting to note here that the hardware cost of a complete OMEGA receiver using this method will be considerably less than the cost of the recorder used to display the data, even considering low-cost recorders of the Rustak type. A more detailed view of the front control panel for a prototype OMEGA receiver which uses this method of display is shown in Figure 13 where the small pin jacks are used with external recorders for the LOP's.

XII. CLOCK OFFSET ERROR

The up/down counting system for the 4 bit D/A or the 8 bit interface will produce a consistent systematic error which is a function of how far the clock drifts between the station pairs selected. It pays to have a clock oscillator with a fine frequency trim (such as the General Time GT-500) which can be set for a low bit drift over the time interval between stations. In the worst case, such as using station pairs separated by half of a full OMEGA sequence, this implies about 4 seconds between measurements. 1 bit at a 4 bit measurement level is 1/16th of a lane or a frequency offset of $\pm 1/(10200 \times 16) = \pm 6 \times 10^{-6}$. 4 seconds will require 4 times better precision or $\pm 1.5 \times 10^{-6}$. This is about the practical limit of many of these low-cost quartz crystal oscillators. A common case is that the oscillator will be off by about 1 bit per second. In addition, the processor will have a 1 bit round-off error. Thus, the reading of a particular LOP by the simplest D/A technique will be off from the true position of the LOP (as measured by a more precision OMEGA receiver) by as much as 10 centilanes one direction or the other.

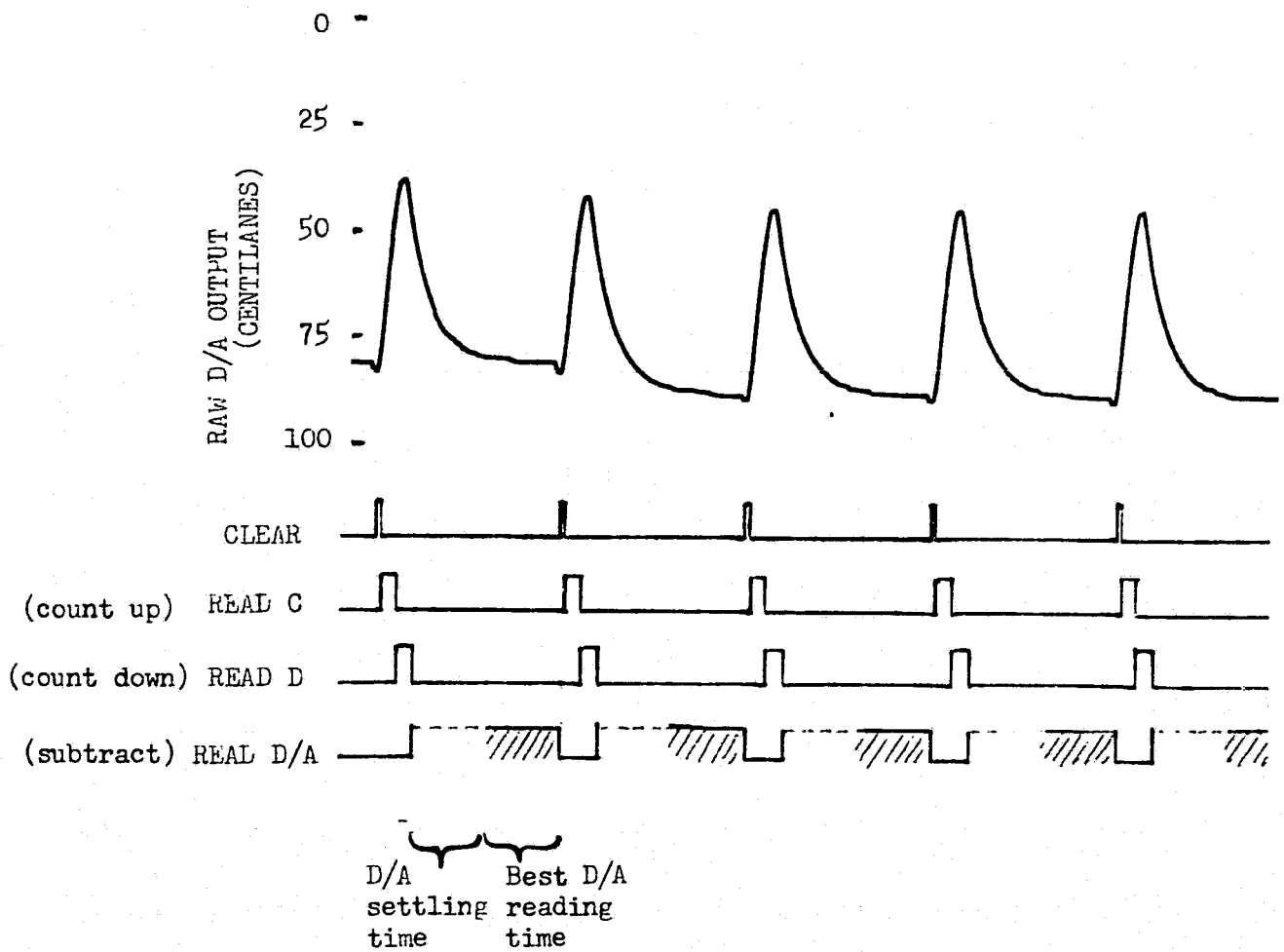

Figure 11. Operation of 4 Bit LOP Display.

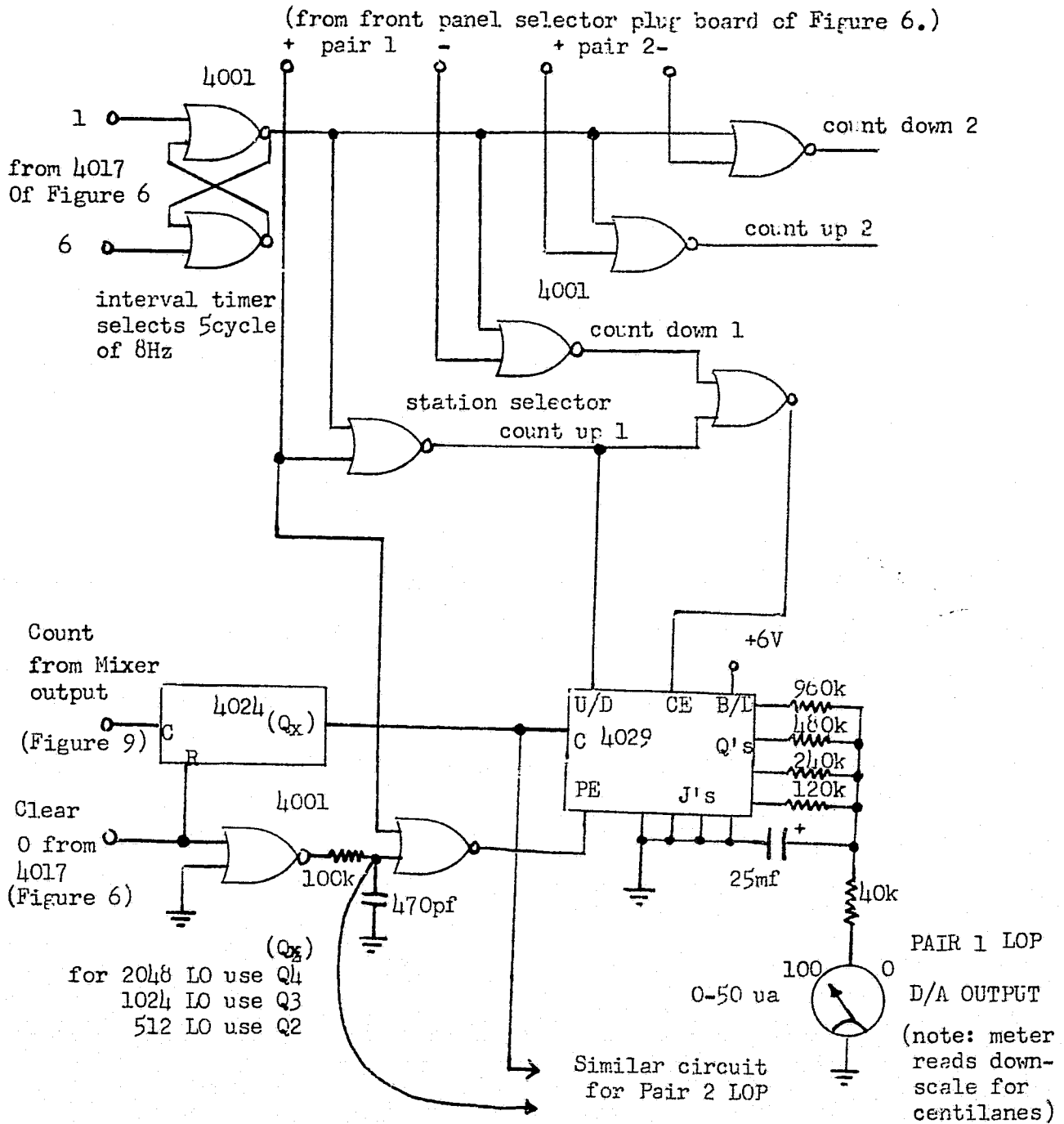

Figure 12. 4 Bit D/A LOP Display.

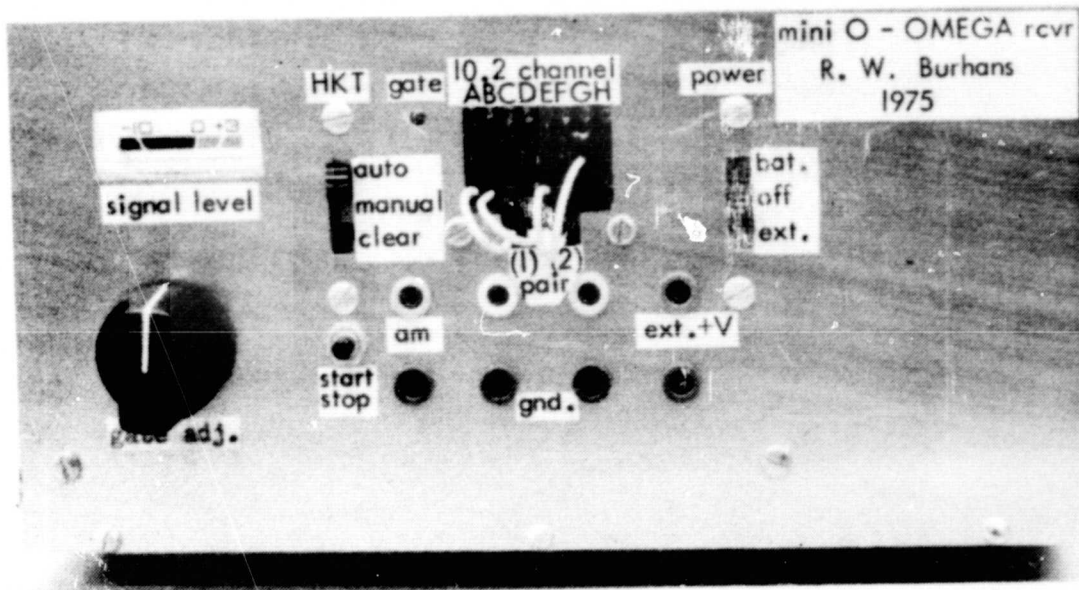

Figure 13. Front Panel of OMEGA Receiver.

ORIGINAL PAGE IS
OF POOR QUALITY

The navigator can calibrate his receiver LOP output to take account of this offset by measuring a single station using one direction counting (such as count up only) over several 10 second intervals. The count trend will keep increasing or decreasing by some fixed number and the difference between these 10 second samples is an estimate of the clock offset in terms of an OMEGA lane over 10 seconds when the receiver is not moving. In a microprocessor system this error can be subtracted with a sophisticated program. However, in the simple D/A output the navigator should keep track of his receiver calibration offset on some kind of daily basis. Fortunately for most clocks, this is a fairly constant calibration number which will not vary much from day-to-day provided that the environment of the crystal oscillator reference is not subject to wide changes in temperature. In a typical watch crystal oscillator, the offset will be of the order of 10% of a lane but usually in the same direction such as always 10% high on a daily basis.

The marine navigator should keep in mind that OMEGA is a system which provides ± 1 mile type of precision at best, is most useful as a dead reckoning navigation aid to help keep track of velocity changes, and should be used on a relative basis and not on an absolute position basis unless some very sophisticated computer processing with multiple frequencies and precision time-frequency references is used. Some cross check on the OMEGA readings, such as the use of simple dead reckoning with heading-speed-time input, is always wise wherein the two navigation methods (OMEGA-DR) combine to give a better position estimate than either one separately.

XIII. BENCH AND FIELD TESTS

The 4 bit D/A method of Figure 11 and 12 was used to investigate the internal clock offset and drift problem. Figure 14 is a series of recordings over a period of several hours showing the diurnal change from a reading of 10 centilanes to about 25 centilanes for the pair C-D after local sunset. This was recorded using 1024 Hz as the LO frequency. In Figure 14(a) the General Time, GT-500, clock of Figure 8 was used. The clock has a small trimmer which was adjusted for a low offset. The use of a 1 second RC filter at the D/A output and no blanking provides a convenient way of observing the entire sequence of operations including the comparison with the clock as each signal is processed. The downward moving peaks are the clock comparison with the C channel immediately after the short clear pulse to which the recorder does not respond. This D/A clock offset response lags behind the actual reading but the trend is easily observed. The slope of the clock constant offset stands out compared to the C-D phase which is reasonably flat at a 10 centilane level over this half-hour period of Figure 14(a). These single time slot raw OMEGA phase measurements will always be contaminated with a certain amount of noise. One noise burst producing an excursion to 100 centilanes is apparent about 2/3rds through the record of Figure 14(a). In this case, the change was from an error in the opposite direction from a centilane reading of +10, through zero, to +100 or a Lane Change which is only 3 counts away.

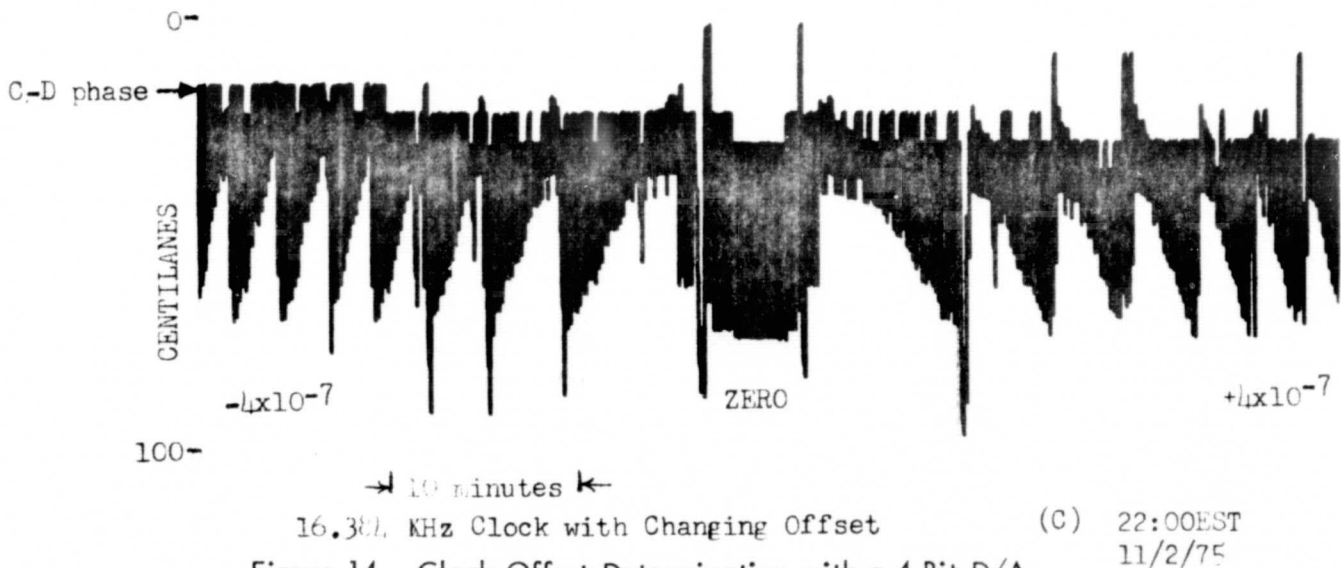
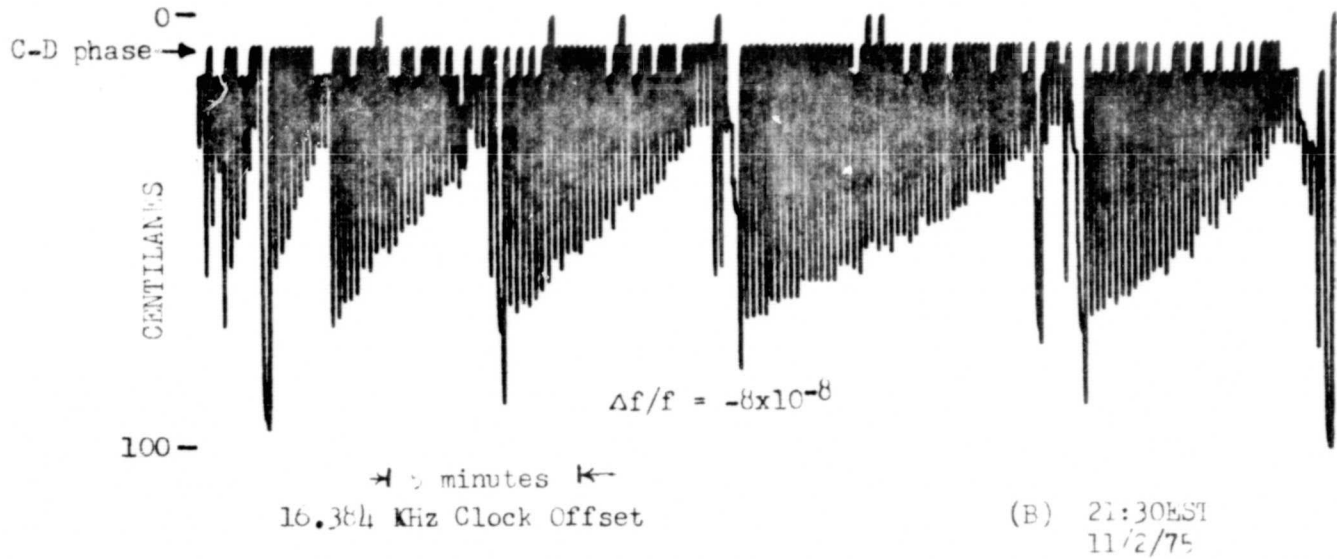
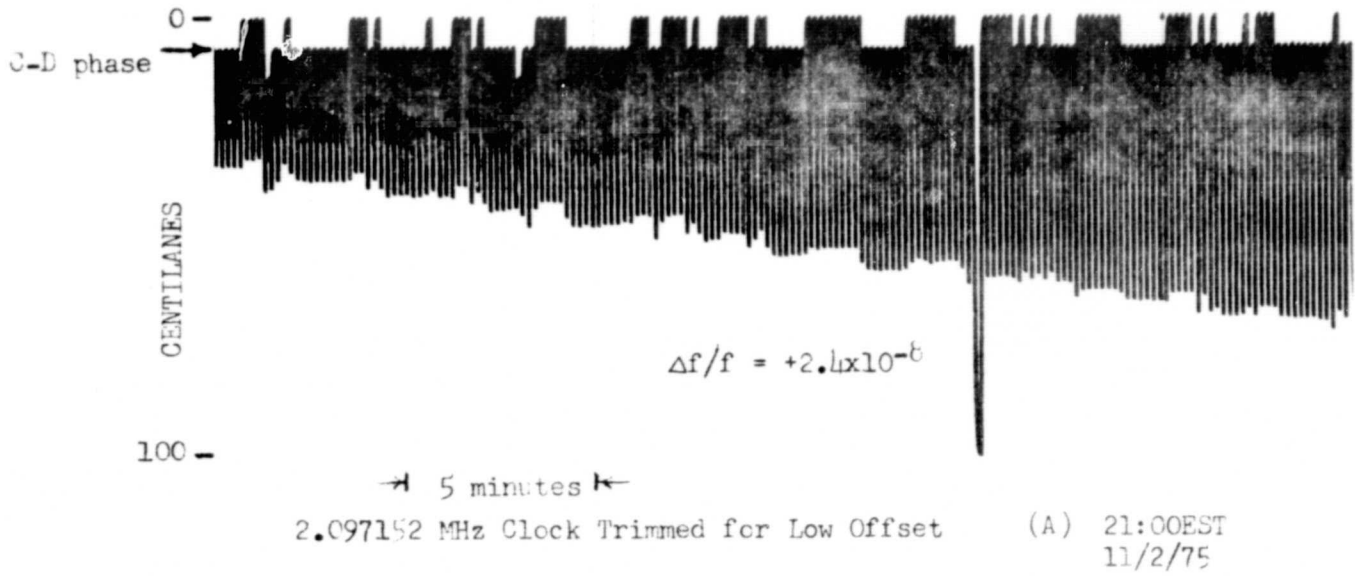

Figure 14. Clock Offset Determination with a 4 Bit D/A.

In Figure 14(b) the clock was changed to the low-frequency 16384 Hz crystal. The initial warm-up drift shows an offset of about -8×10^{-8} after 15 minutes. A reading of this same clock about an hour later, Figure 14(c), shows a change of the clock offset from -4×10^{-7} through zero to $+4 \times 10^{-7}$. This type of behavior is common with many of the uncompensated low-frequency oscillators and is due in this case to slow drift in the receiver power supply battery voltage and temperature changes in a non-air-conditioned room.

Figure 15 illustrates the same clock about 4 hours later where the 16.384 KHz crystal has settled down to a frequency offset with respect to OMEGA of about $+1 \times 10^{-6}$. The continual ratcheting of the local clock with a phase change of about one cycle every 50 seconds or so, will produce a phase offset in the C-D lane of about one bit in this example, but the C-D lane diurnal phase trend going from 30 centilanes to 40 centilanes over a period of an hour is easily observed in the presence of this offset clock. The marine navigator might use a similar type of recording display which will give him a rapid idea of the relative magnitude of his clock drift with respect to the particular OMEGA LOP being measured. If the clock appears to be ratcheting through the OMEGA LOP too fast, he (the navigator) can tweak his clock back to a more comfortable setting as in Figure 14(a) or 14(b). It is not possible to determine the absolute clock error in these types of measurements when the receiver is moving. However, the relative change is easily observed.

Figure 16 is a photograph of the receiver and a single LOP indicator mounted in a VW bus for mobile field tests. The regular AM radio antenna was used with a cable adapter to the OMEGA receiver preamplifier. The added shunt capacitance of the connecting cable reduces the receiver sensitivity somewhat. Reception is possible in most all open country locations but is relatively poor in urban areas where there is a lot of AC power line interference. Excellent performance was obtained on hill top locations and while parked in a river valley which was considerably below the nearby hill tops a kilometer or so away. The auto antenna physical length was about $1\frac{1}{2}$ meters here with the last $\frac{1}{2}$ meter extending above the roof of the microbus. The effective length of the antenna or sensitivity changed markedly with location. In particular, very low sensitivity was observed when the automobile is close to trees or buildings which provide a large capacitance shield for the antenna. The antenna in these cases looks like part of the earth ground system, whereas it should operate like a very small probe protruding slightly above the dominating nearby earth ground plane. In the practical navigation case of the marine or airborne system, this earth shielding effect is usually not a problem.

Figure 17 is a photograph of a lab bench test arrangement illustrating the use of the GT-500 clock, a strip chart recorder, a meter indicator for one LOP, and the prototype receiver system. Figure 18 is a detailed view of the top of the circuit board of the receiver. Figure 19 is an illustration of the 10200 Hz Test Oscillator.

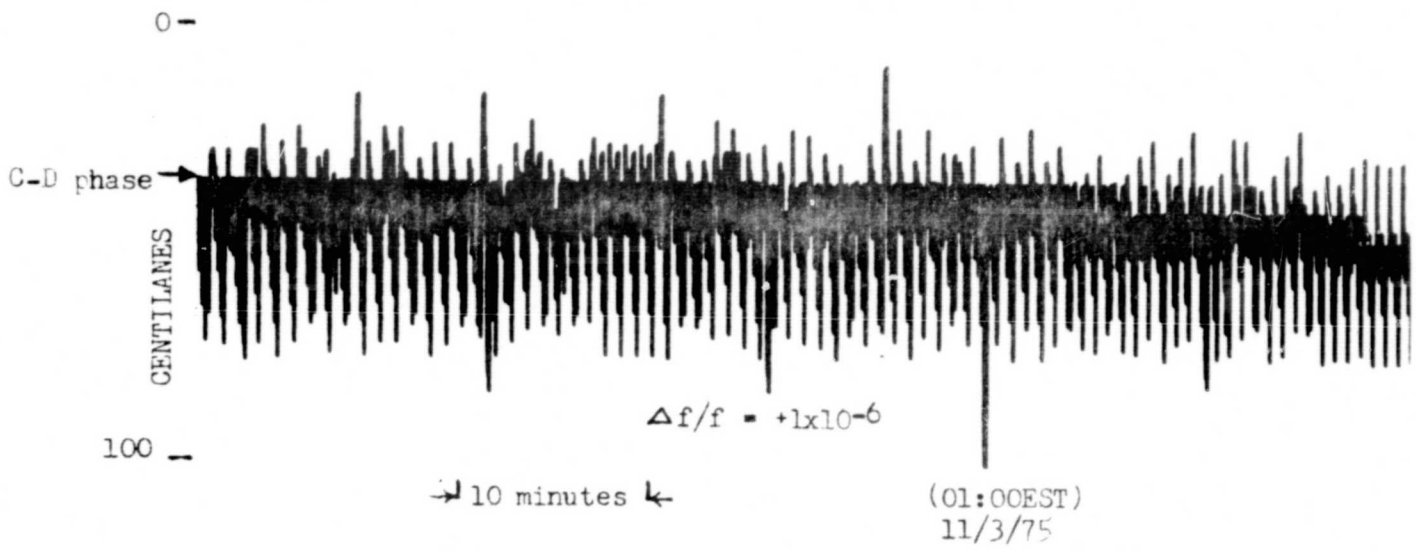

Figure 15. OMEGA Phase Subtraction with Large Clock Offset.

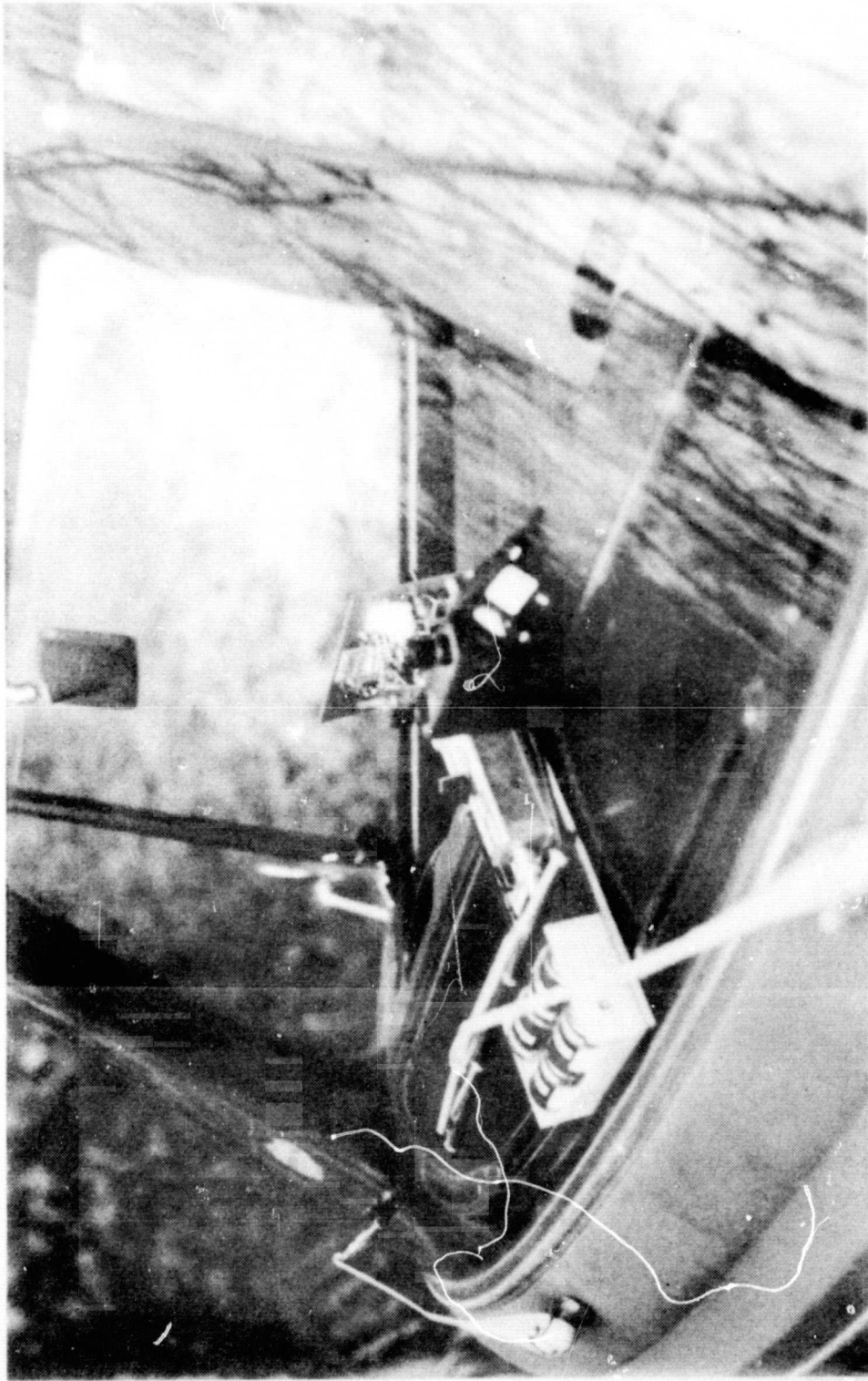

Figure 16. Mobile Field Tests in VW Microbus.

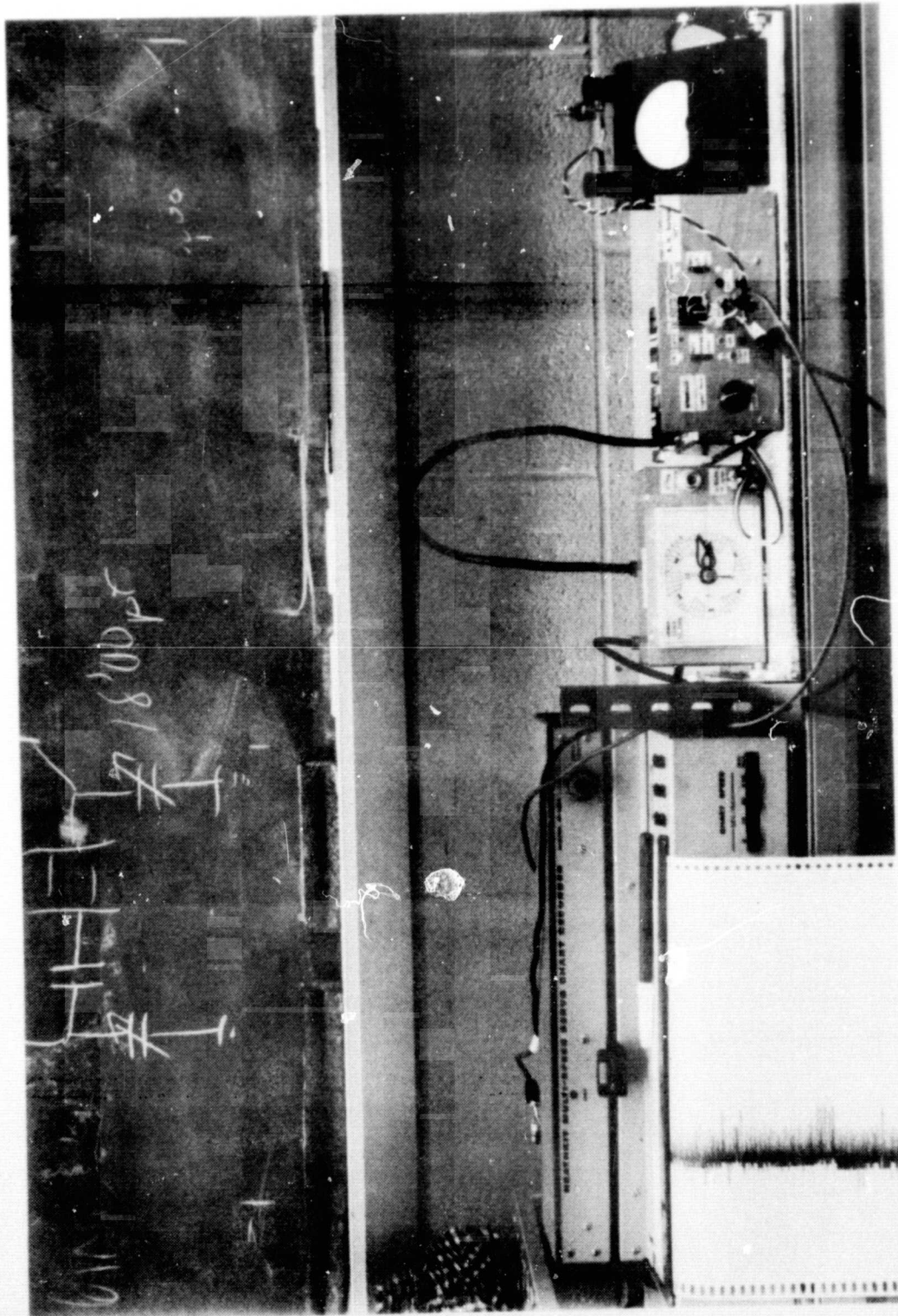

Figure 17. Lab Bench Evaluation of OMEGA Receiver.

ORIGINAL PAGE IS
OF POOR QUALITY

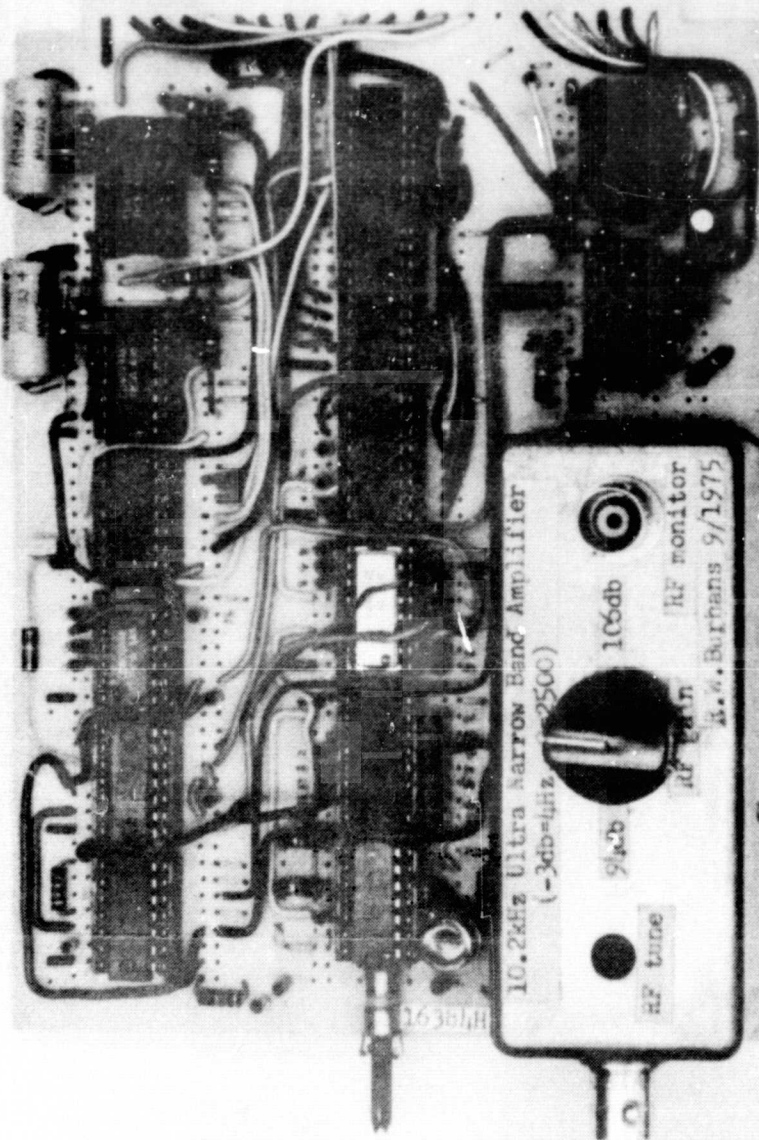

Figure 18. OMEGA Receiver Circuit Board.

ORIGINAL PAGE IS
OF POOR QUALITY

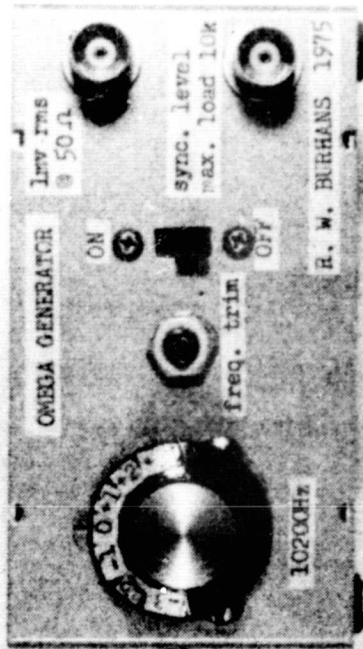

Figure 19. OMEGA Signal Source.

ORIGINAL PAGE IS
OF POOR QUALITY

XIV. MULTIPLEXED DISPLAY FOR MARINE USE

A possible method of further reducing receiver cost for the small boat owner would be the use of a single channel recorder with sequential sampling of station pairs for several minute measurement periods. Figure 20 is an example of such a 4 bit raw OMEGA phase output for pair combinations, B-C, B-D, and C-D with 5 minute sample intervals. A small boat moving at 16 knots might cross a lane ($\frac{1}{2}$ wavelength) roughly every half hour. With 3 pairs this gives two samples/lane change in the worst case moving parallel to the station pair baseline. A shorter sample interval, such as 2 minutes/station, as well as the use of only two station pairs would provide a more detailed picture to the navigator. The display of Figure 20 could be further improved using a clock comparison blanking latch on the D/A output and a 6 or 8 bit D/A. Another feature that might be desirable in a marine system would be a provision for either blanking the clock comparison or not blanking so that the navigator could check his clock offset when desired, but have more smoothing for normal operation in the blanking case.

XV. WEAK SIGNAL SENSITIVITY FOR RAW PHASE

Figure 21 is an interesting recording showing the relatively high sensitivity possible for weak signals on the 4 bit D/A phase measurement. In the mid-western USA (Ohio), channel A at Norway on 10.2 KHz is difficult to receive in an urban ground monitor installation. The first 10 minutes of sampling the pair A-B shows a definite trend of a LOP about 40% of the time between a value of 40 to 60 centilanes. A TRACOR 599R receiver operating at the same time gave a similar erratic reading on the A-B pair of 45 to 55. A well-programmed microprocessor system could probably clean-up this data considerably. The other 10 minute intervals are: noise on G-H when there was no signal on G with the long range H signal from Japan not transmitting at the time, and the relatively strong C-D pair which gave a reading of 15 to 20 centilanes 90% or more of the time in this example.

XVI. OTHER APPLICATIONS

The general idea of using digital mixing methods may have further application in much more sophisticated phase processors which use other clock frequencies (not necessarily binary) such as a direct decimal display and tracking system. It should be possible to conceive of digital heterodyne combinations, without harmonic locking problems, or spurious responses, by proper choice of the clock frequency and the intermediate frequency generated. An advantage for high frequency systems is that the clock required can be the same order of magnitude as the signal frequency and not several orders of magnitude higher as is the case of many presently implemented digital phase measurement circuits. In effect, a digital superheterodyne receiver has been demonstrated to work here which should have application to other types of communications problems as well as frequency counters.

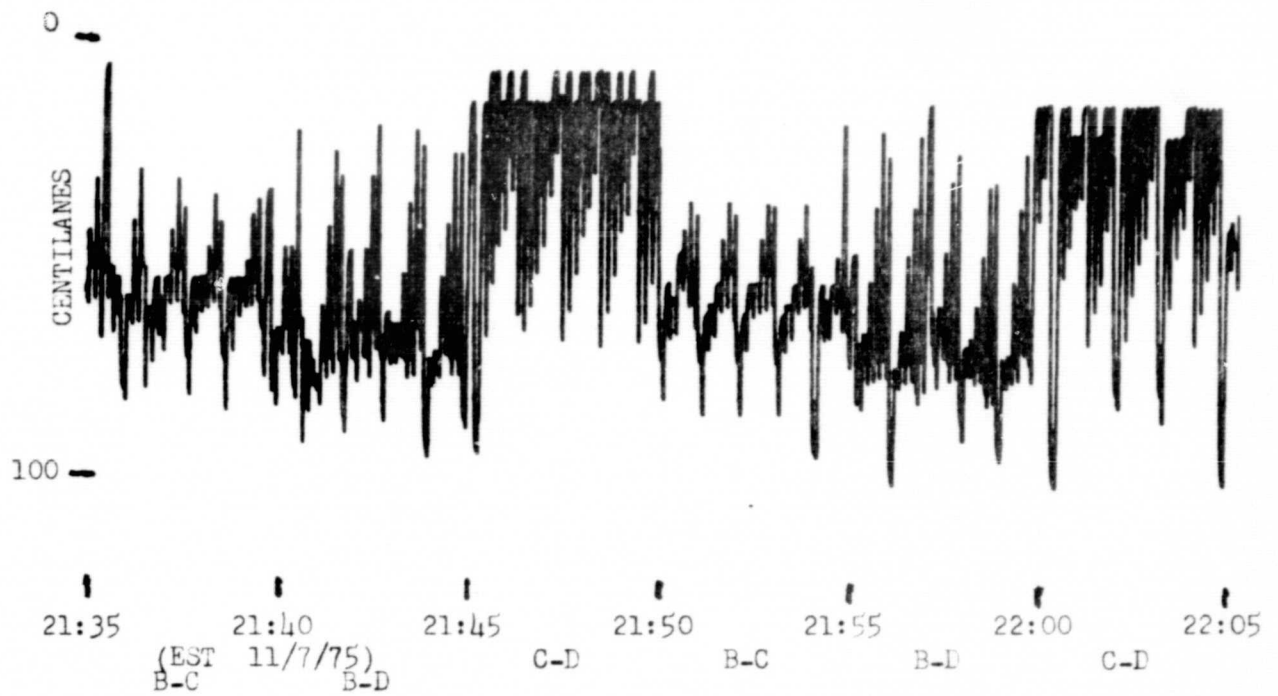

Figure 20. 5 Minute Multiplexing of Raw OMEGA Phase.

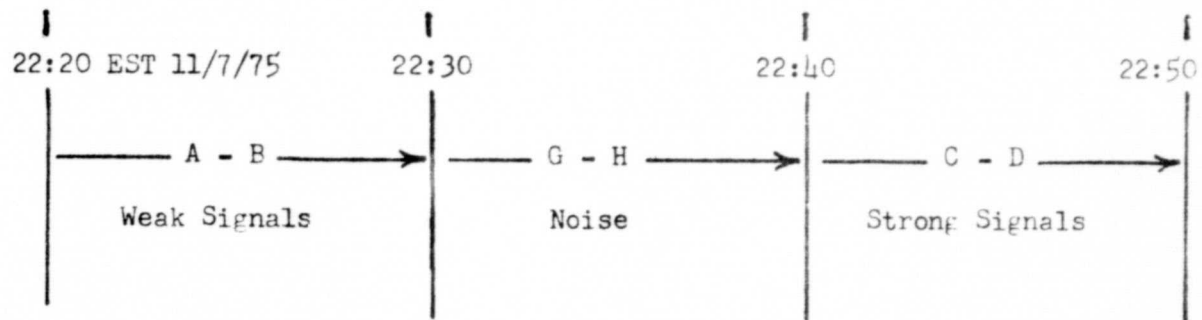
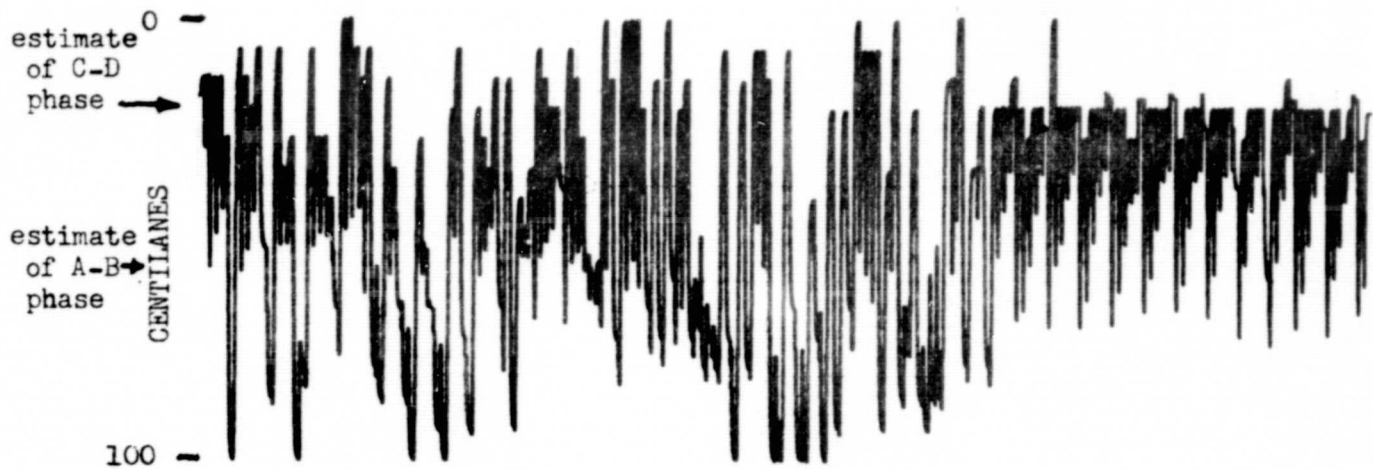

Figure 21. Raw OMEGA Phase for Weak Signals.

XVII. FUTURE

It is anticipated that a circuit board kit will be developed using some combinations of the methods disclosed here. This will provide the lowest possible cost OMEGA receiver system for those skilled in the modern art of electronic fabrication, as well as provide a do-it-yourself OMEGA receiver system capable of being expanded with microprocessors in a variety of ways to suit the needs of the individual user. A considerable advantage of a simple type of OMEGA receiver, such as the one suggested here, would be in educating the user public in the basic techniques of receiver operation at a cost roughly an order of magnitude less than any comparable OMEGA equipment now available. The modern day trend to do-it-yourself computer systems made possible by the advent of low-cost microprocessors is in need of some applications besides game playing and cost accounting.

XVIII. ACKNOWLEDGEMENTS

The author wishes to acknowledge:

Mr. Don Lancaster of Synergetics for suggesting trying the STATEK quartz crystal as filters.

Mr. Richard Nelson of the STATEK Corporation for supplying samples and possible methods of using quartz tuning fork filters.

Dr. Richard H. McFarland and Dr. Robert W. Lilley of the Ohio University Avionics Engineering Center for long term encouragement in proceeding on this problem.

Professor G. E. Smith of the Ohio University Department of Electrical Engineering for advice throughout the course of the project.

Mr. Richard Salter, Mr. Kent Chamberlin, Mr. Lee Wright, Mr. Steve Grimm, and Mr. Gerald Bryan for help on some of the test and circuit development details.

The NASA Langley Research Center for support under Grant NGR-36-009-017 for which some of this work was conducted.

XIX. REFERENCES

- [1] R. W. Burhans, "Simplified Omega Receivers", Technical Memorandum (NASA) 4, Avionics Engineering Center, Ohio University, Athens, Ohio, March 1974.

- [2] R. W. Burhans, "Phase-Difference Method Offers Low-Cost Navigation Receivers", *ELECTRONICS*, 47, pp. 98-105, September 5, 1974.
- [3] K. A. Chamberlin, "Binary Phase-Locked Loops for Omega Receivers", *Proc. of the 2nd Omega Symposium*, ION, Washington, D.C., pp. 154-158, November 7, 1974.
- [4] R. W. Burhans, "Simultaneous Master-Slave Omega Pairs", *IEEE Trans. Aero. and Electronic Syst.*, Vol. AES-10, No. 6, pp. 895-898, November 1974.
- [5] Bulletin F-004B, STATEK Corporation, 1200 Alvarez Avenue, Orange, California 92668.
- [6] R. W. Burhans, "Single Preamplifier/Isolator Drive LF and VLF Receivers", *ELECTRONICS*, 48, No. 18, pp. 107-108, September 4, 1975.
- [7] R. W. Burhans, "Low-Cost, High-Performance, VLF Receiver Front-End", *Technical Memorandum (NASA) 18*, Avionics Engineering Center, Ohio University, Athens, Ohio, September 1975.
- [8] "Phase-Locked Loop Systems", *Data Book*, 2nd Edition, Motorola Semiconductor Products Inc., Phoenix, Arizona 85036, August 1973.

XX. APPENDIX

A. Flight Test Results

A short test flight with the receiver installed in a DC-3 aircraft was conducted in the late afternoon of November 21, 1975. The flight path, Figure A-1, was from the Albany, Ohio airport to the Henderson, West Virginia VOR, and return for a round trip of about 60 miles. Excellent signals were observed from OMEGA stations B, C and D on 10.2 KHz. The A signal from Norway was borderline and was not used. Figure A-2 is a section of a high speed chart recording of the signal levels where the D channel is saturating the limiter with the B and C signals clearly defined above the receiver noise level. Towards the end of the flight, the aircraft was flying through some light snow but no precipitation static disturbance was noted in the envelope recording.

Recordings of the raw phase output from pairs B-C and C-D along with the envelope output on the return portion of the flight are shown in Figure A-3. The B-C record shows more clearly than the C-D record because the flight path did not cross a C-D lane during this part of the test due to the much wider spaced LOP as illustrated in Figure A-1. The GT-500 clock offset for this flight was about 5×10^{-6} . This high an offset confuses the 4 bit D/A output somewhat. A portion of the record during the down leg and turn after passing the VOR station is shown in Figure A-4. Here the B-C and B-D pairs were being recorded. Two lane changes and the turn skimming the edge of a B-C lane can be seen in the raw phase output. However, the B-D phase is obscured by the high clock offset. The raw OMEGA phase output here emphasizes the need for a blanking latch on the D/A output when the receiver is moving at a relatively high velocity with a high clock offset error.

A short burst of 60 Hz type interference was noted on the signal level just before touchdown as seen in Figure A-3. This is believed to have been caused by the high intensity strobe lights at the edge of the Albany airport runway which were operating just below the aircraft flight path prior to touchdown. The 60 Hz high current short pulse nature of this type of lighting system is suspected of radiating some broadband RF noise which may have caused the momentary disturbance apparent towards the end of the envelope recording of Figure A-3. A signal or receiver failure was noted earlier in the same recording. The cause of the missing two 10-second OMEGA sequences is not known. The aircraft was flying through some wet snow at the time, and possibly this could be caused by a small piece of ice which shorted the wire antenna input insulator for a short period of time before being dislodged in the slipstream.

The takeoff part of the flight and a 4 minute section after the VOR turn are not illustrated in Figures A-3 and A-4. A higher chart speed was being used in the early part of the flight and the receiver was being changed over to the C-D pair during the time that the return flight crossed the Ohio River.

These initial flight test results indicate that the ultra narrow band front-end system with a 4 Hz bandwidth may be quite usable in airborne systems. However,

the phase measurement technique needs to be improved somewhat, probably by using a microprocessor filtered measurement method to present OMEGA data to the pilot in a more usable form. Also, the clock offset should be set to a value less than 5×10^{-6} if possible.

B. VLF Interference

Figure A-4 illustrates some interesting changes in the baseline noise level of the signal envelope output which might be caused by radiation from various ground sources. Particularly the slight hump or increase when flying over the VOR station might be significant.

The preamp used for the test flight did not have a bleeder resistor at the antenna to reduce static charge; therefore, any direct rectification at the preamplifier input might be expected to produce a small charge on the input JFET gate. This might affect the gain of the stage. However, more likely is the fact that a VOR station has a strong 30 Hz modulation which could be detected given sufficient non-linearity in the front-end, and the 340th harmonic of 30 Hz is exactly 10200 Hz. Thus, anything that has a strong 60 Hz harmonic or subharmonic component might cause interference. The effect was noted on the down leg passing over the VOR and on the return passing back again over the beacon on the return leg. This problem might be cured by using a bleeder resistor at the antenna input to reduce the tendency for non-linear behavior on very strong interference that has some 60 Hz line component in the modulation of the carrier.

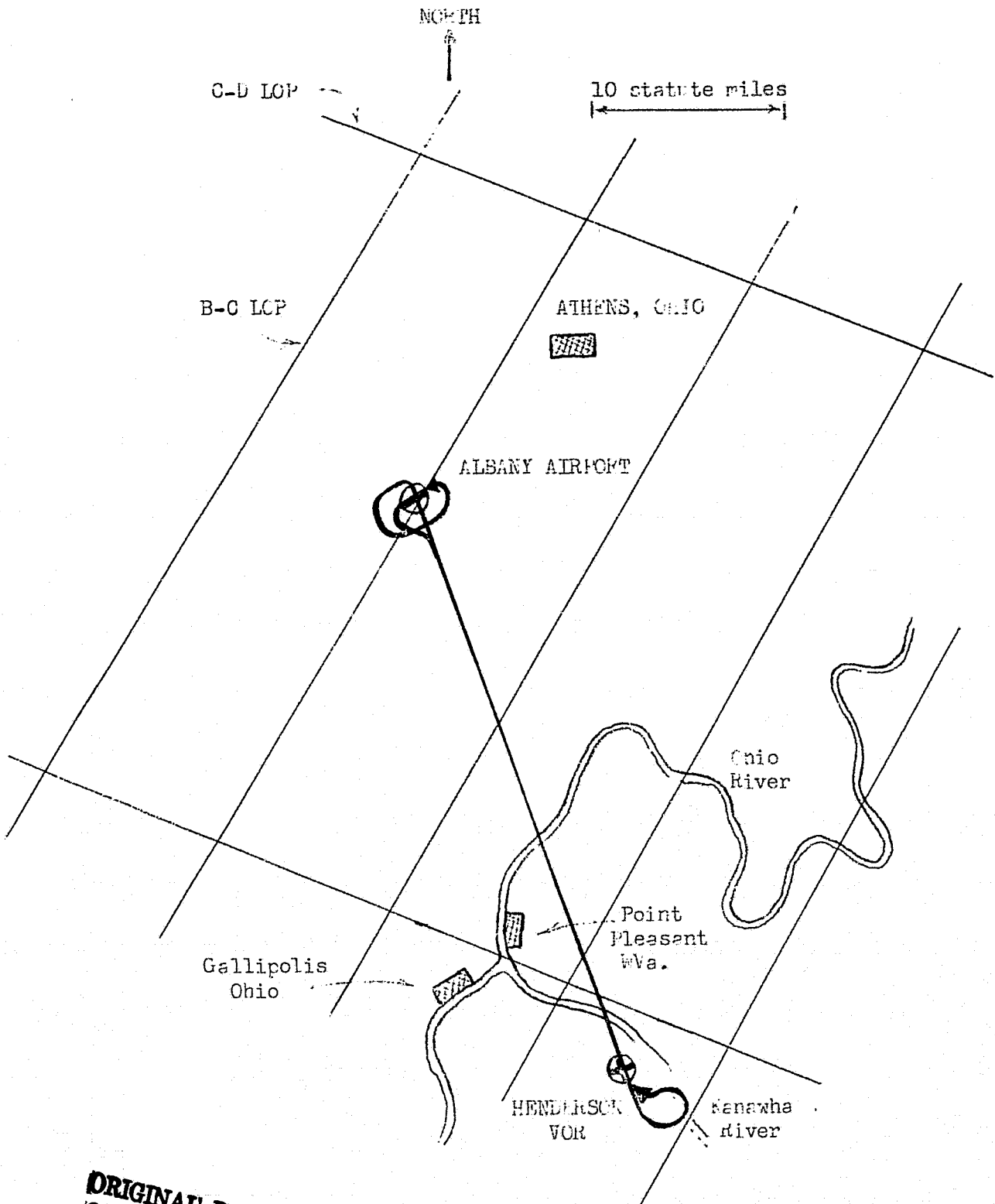

**ORIGINAL PAGE IS
OF POOR QUALITY**

Figure A-1. Test Flight Path.

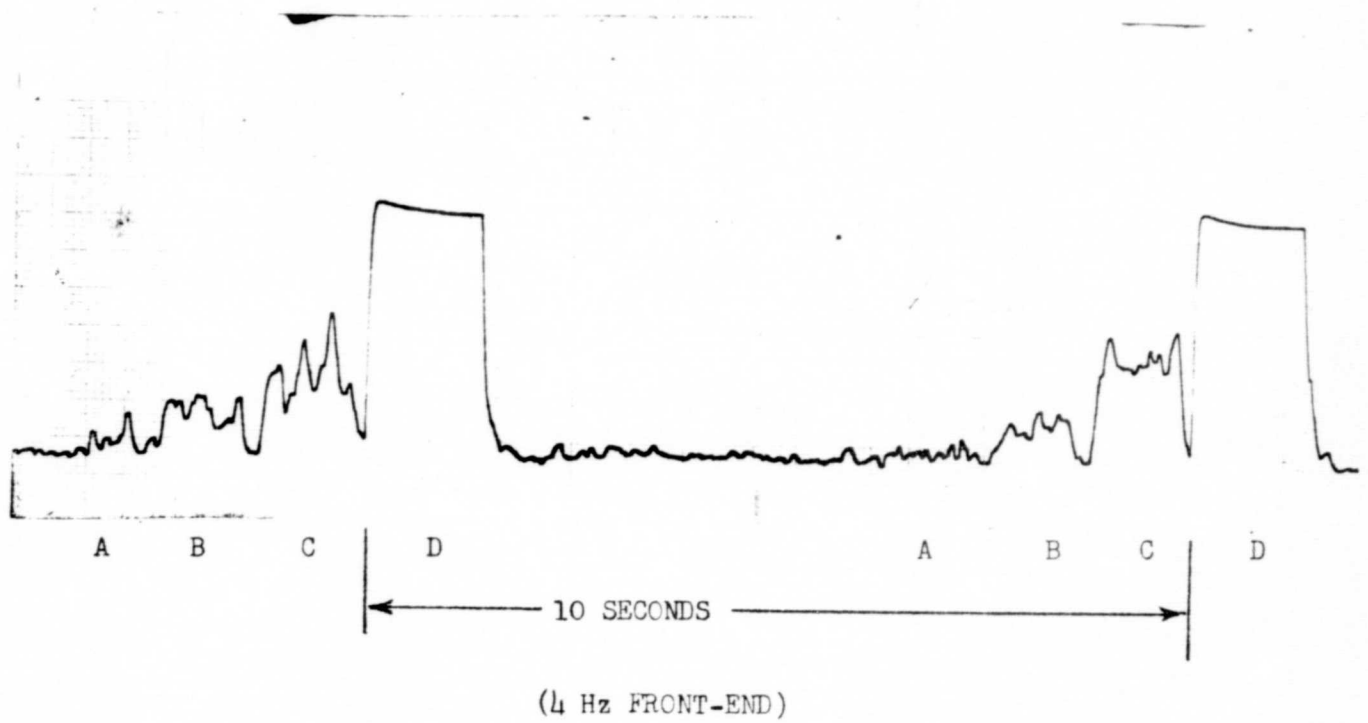

Figure A-2. Signal Envelope During Test Flight.

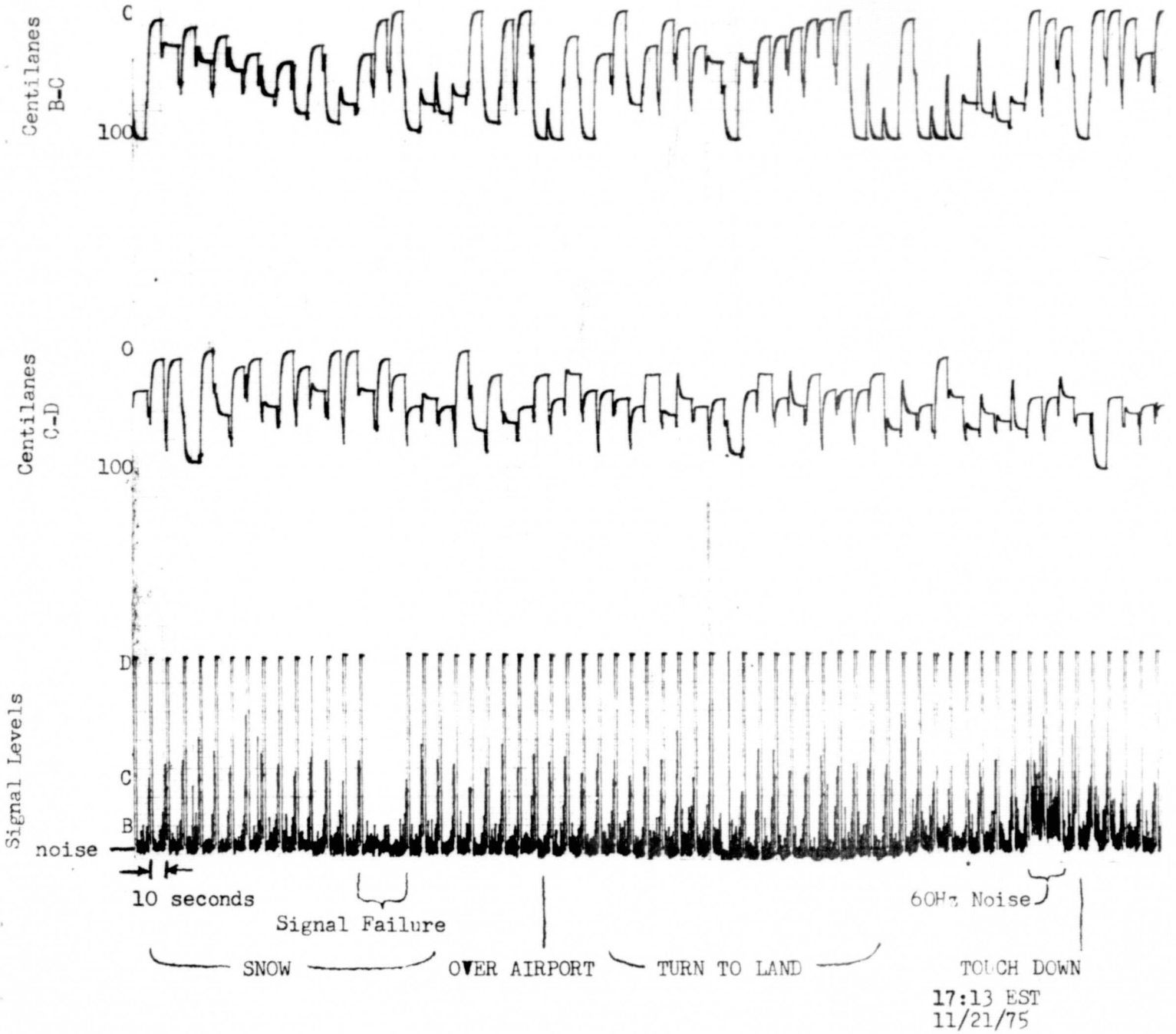

Figure A-3. Test Flight Record, Approach and Landing.

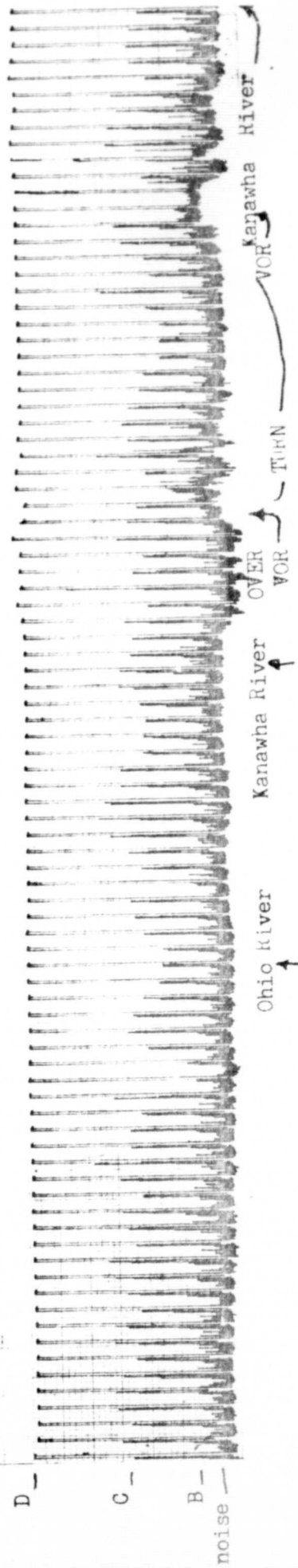
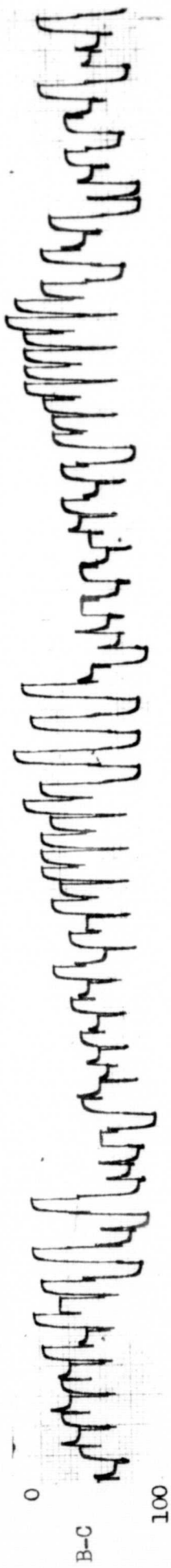

Figure A-4. Test Flight, Down Leg and Return.