

N76-19194

22. A DAMPER FOR GROUND WIND-INDUCED

LAUNCH VEHICLE OSCILLATIONS

By John G. Bodle and David S. Hackley

GENERAL DYNAMICS CORPORATION

Convair Aerospace Division

San Diego operation

SUMMARY

Prelaunch oscillatory bending deflections of the Atlas/Centaur launch vehicle are restrained by a damper mechanism mounted on the end of a horizontal boom supported from the umbilical tower. A single vertical pin on the vehicle engages the mechanism. The damper is connected to the vehicle until liftoff. As the attach pin rises with the vehicle, a retractable arm mechanism provides initial clearance. An explosive release mechanism allows the boom to swing clear of the vehicle like a pendulum. A snubber mechanism decelerates the free swinging boom and damper mechanism to a safe stop.

INTRODUCTION

The Atlas/Centaur* launch vehicle shown in figure 1 has evolved from initial development as booster for "Surveyor" to present day versatile mission capability. This evolution has produced a 5.5 meter increase in length. As length increased, potential for severe ground wind induced vehicle bending loads became acute. Restrictive ground wind velocity limits threatened to reduce availability for small effective launch windows.

* The Atlas/Centaur is built by General Dynamics Convair Aerospace Division, San Diego operation. Program management is by NASA Lewis Research Center (LeRC), Cleveland, Ohio.

Ground wind aerodynamic forces on the Atlas/Centaur launch vehicle produce bending deflections. The phenomenon of vortex shedding creates oscillatory deflections which reach maximum amplitude within a plane normal to the wind direction. The allowable bending moment limit for the vehicle may be reached at 50% lower wind speed when oscillatory deflections are combined with the steady state deflections. Addition of a damper to reduce oscillatory deflection thus became a prime objective.

In 1972, under the direction of NASA LeRC, General Dynamics Convair Aerospace (GDCA) developed a system concept for an oscillation damper for Atlas/Centaur. In April 1973, NASA LeRC directed GDCA to implement the oscillation damper system at Cape Kennedy, Launch Complexes 36A and 36B to provide for the October 1973 launch window of Mariner 10.

The system was to be designed to remain in place until vehicle liftoff. Adequate clearance was to be provided during vehicle liftoff to preclude the addition of restrictions on vehicle drift. The retraction system was to be redundant. Extension and engagement with the vehicle was to be performed manually only. The damper was required to permit unrestricted operation for actual ground wind speed up to 33.6 knots for all tanking conditions with the Atlas fuel tank full.

The two basic system functions are described. First, the damper system, which performs the required damping until liftoff. Second, the retraction system which retracts the damper mechanism and support boom at liftoff.

DAMPER SYSTEM DESCRIPTION

The installed damper system is shown in figure 2. The two main elements of the system are the damper mechanism and the support boom with its counterweight. The system is installed on the umbilical tower below the level of the Centaur stage umbilical booms. The damper mechanism is connected to the vehicle by a single attach pin near the lower end of the interstage adapter. This is not the most advantageous point for applying the damping force, but was dictated by the limited height of the Complex 36A umbilical tower. Attachment near the forward end of the vehicle would have provided a longer moment arm for the applied damping force for more efficient damping.

The damper mechanism, shown in figure 3, is a linkage differential mechanism, formed by three equidistant parallel sliding bars pinned to a cross bar. The center bar is a linear ball bearing guided splined shaft. The spline prevents rotation of the mechanism about the centerline of the shaft. The ball bearings are essential to minimize friction forces. The two outboard sliding bars are the piston shafts of balanced double acting hydraulic

dashpots. The dashpots have the same damping coefficient in both directions of travel. The cross bar, referred to as the cross head, and the retractable arms form a rigid bellcrank when the vehicle attach pin is fully engaged. The vehicle attach pin and the dashpot rod end bearing centers are located an equal distance from the pivot pin in the splined shaft. The error due to dashpot angular motion is negligible for the small amplitude oscillatory travel of the attach pin (5.77 cm, zero to peak maximum).

The damper mechanism is mounted on the end of a rigid support boom. The boom is hinged at the base to swing vertically. A cable is connected at one end near the end of the boom, routed through a pulley elevated on the umbilical tower, and connected at the opposite end to a counterweight. This counterweight not only supports the weight of the horizontal boom, but maintains an upload on the end of the boom to keep the damper mechanism fully engaged with the vehicle attach pin until liftoff.

DAMPER SYSTEM DESIGN

Damping Coefficient

The Atlas/Centaur launch vehicle deflects like a cantilever beam from drag and lift loads induced by ground wind. This deflection includes a steady state (static) component and an oscillatory component as illustrated in figure 5. The oscillatory component is not linear due to the individual components of lift and drag. When added vectorially, the total resultant deflection must not exceed the limits allowed by the strength of the vehicle and launcher. The relative characteristics of ground wind loads are shown in figure 6. The damper has no effect on static deflections. The oscillatory deflections, which create the most severe wind velocity constraints, are significantly reduced with a damper.

The damper was required to increase the modal damping factor of the vehicle from an average value of 0.03 to 0.43 for the most critical case where only the Atlas fuel tank is filled. A viscous damping coefficient range of 840.6 to 1,260.9 N/cm/s was computed for the damper. A design load of 8900 N maximum was established for the vehicle attach pin and the local structure of the interstage adapter wall. This required the damper to be force limited as a precaution against structural damage in the event the wind loading exceeded the maximum design requirement. The damping coefficient and force limit for each dashpot in the mechanism is half the total required. The resulting damping characteristic envelope for the dashpots is shown in figure 10.

The computed viscous damping coefficient for the damper mechanism was derived assuming an infinitely stiff umbilical tower. A simple test of the overall system was performed at Complex 36B. The vehicle was manually deflected, then suddenly released. The decaying oscillatory response was then recorded. This test indicated the umbilical tower was less rigid than anticipated. The derived viscous damping coefficient was, however, found to be satisfactory.

Damping Force and Direction

Vehicle oscillation in any direction is damped by an opposing force at the attach pin proportional to pin velocity. The constant of the proportionality is the viscous damping coefficient. When the attach pin moves there is, in most cases, a component of force normal to the direction of travel as shown in figure 4. The magnitude of the normal force component is a function of the following factors:

- 1) Difference in damping coefficient between the two dashpots due to tolerances on the specified damping coefficient.
- 2) Bearing friction on the splined shaft.
- 3) Inertia loads of the mass and mass moment of inertia of the cross head and arms assembly and the mass of the piston rods and splined shaft.
- 4) Initial offset of the neutral position of the attach pin from the splined shaft centerline caused by vehicle misalignment, umbilical tower deflections and steady state wind deflections of the vehicle.

Examples of computed damper mechanism force dispersions are shown in figures 8 and 9. A linear sinusoidal displacement of the attach pin is applied in directions between $\beta = 0$ and $\beta = \frac{\pi}{2}$ rad. A typical difference in dashpot damping coefficients in both the linear and load limiting range was used. Friction, dashpot hysteresis and force deadband due to bearing clearances are neglected. Forced oscillation tests of the damper mechanism proved these effects to be minor. The mechanism is assumed to be rigidly supported.

In figure 8, both dashpots are operating in the proportional range. The maximum normal force is 8.5% of the corresponding collinear force for a 5.08 cm initial offset in the worst direction. This is 6.2% greater than for zero off-

set. The variation in collinear force with direction of travel is primarily caused by the difference in damping coefficient between the dashpots. With the travel at $\beta = \frac{\pi}{4}$ rad, only one dashpot is working. In this particular case, it is the one with the greater damping coefficient. Thus, the collinear force is greatest when $\beta = \frac{\pi}{4}$ rad.

Figure 9 shows the force dispersions in the force limiting range of operation at maximum design velocity for two directions of travel. The normal forces for the directions shown are less than 9% of the collinear force. For intermediate directions of travel, e.g.: $\beta = \frac{\pi}{3}$ and $\frac{\pi}{6}$ rad, normal forces of nearly 43% of the collinear force occur due to the unbalancing action of one damper going to force limit while the second damper is operating in the proportional range. Collinear force is the least when $\beta = \frac{\pi}{4}$ rad in this case because the force limiting velocity of the working dashpot is reached earlier in the pin travel.

In actual operation, the oscillatory motion at the vehicle attach pin is nonlinear and random rather than linear and sinusoidal. The nature of the motion does not change the force response of the damper mechanism. Analysis has shown the direction of the total damping force does not always coincide with the direction of attach pin motion. In the load limiting range, this difference may tend to change the direction of travel. This is another form of damping since the mechanism is transferring work energy to the vehicle. The effects of this action have not been fully explored.

Travel Limits

The limits of travel of the attach pin are a function of the stroke of the dashpots. The criteria for establishing travel limits were as follows:

- 1) The damper must never limit the bending deflection of the vehicle to less than that calculated from allowable bending moments for the vehicle. This is represented by a circular envelope 23.1 cm in diameter.
- 2) An allowable vehicle vertical misalignment of 2.54 cm in any direction, plus a locating dimensional tolerance for the damper mechanism were included.

- 0
C
€
- 3) Damper displacement due to thermal deflection of the umbilical tower caused by solar heating. This was measured at the appropriate tower station and found to be a total of 1.8 cm maximum for the conditions prevailing during one day in May.

A travel limit envelope consisting of a 30.48 cm diameter circle was selected to satisfy the criteria. Although this does not accommodate the sum of all of the criteria, it was considered improbable that all conditions would occur simultaneously in the same direction.

A 43.18 cm dashpot stroke is required for the damper travel to include a 30.48 cm diameter envelope. Figure 7 shows the boundary of actual travel limit of the attach pin traced by the mechanism.

Dashpot Design

The hydraulic dashpot shown schematically in Figure 11 is a self contained system. The proportional damping and force limiting characteristic is controlled by a pressure modulated spool valve with specially shaped orifice slots. The heat produced by the fluid pressure and shear work across the orifice is dissipated to atmosphere through cooling fins in the aluminum dashpot body. A relief valve allows excess fluid volume from thermal expansion to transfer to a spring loaded accumulator. The accumulator also provides fluid make-up for thermal contraction and leakage loss. Pressure isolation of the primary damping circuit and accumulator is provided by check valves.

The spring nulled spool valve displacement is proportional to the pressure differential (ΔP) across the piston. As the spool moves from the null position, one orifice slot is covered while the other is opened to increase flow area. The exponential shape of the slot provides the proper flow area at each ΔP to produce a flow rate directly proportional to ΔP . The slope of the force vs velocity curve is thus constant within the desired force range. When ΔP has increased to the limit value during piston acceleration, the slot suddenly widens and one spring is relaxed. The slope of the force vs velocity curve is thus reduced abruptly as shown in Figure 11. The reverse sequence takes place as the piston decelerates with some variation due to hysteresis effects.

Attach Pin Design

The attach pin shown in figure 3 connects the vehicle to the damping system. The functions performed by the attach pin are as follows:

- 1) The pin reacts the damping loads.

2. The pin is pulled by vehicle rise without jamming in the arms under all expected motions and deflections.
3. The pin holds the retractable arms extended.
4. Pulling of the pin provides instant release of the arms.
5. The pin support sustains the static and dynamic vertical loads applied by the counterweight through the boom and arms.

These requirements resulted in a cylindrical 17-4 PH pin with an enlarged ellipsoid shape² section in its middle, centrally located in a beryllium copper alloy bushing in the end of the arms. The bushing is the pivot bearing in the outboard joint of the arms. The ellipsoid shape insures localized contact in the bushing without possibility of binding under misalignments and deflections. The lower end of the pin locks the arms in place. The pin is mounted on the lower face of a machined bracket fastened to the side of the vehicle inter-stage adapter.

The boom is preloaded against the vehicle to prevent early release and retraction during vehicle longitudinal oscillations at engine start-up. A counterweight provides this preload by overbalancing the mass of the boom through a cable-pulley system as shown in figure 12. The counterweight must be heavy enough to keep the boom in contact with the pin during vehicle upward acceleration with engine ignition. It must not be so heavy that excessive vertical loads are applied as the vehicle accelerates downward during the thrust buildup transient. Figure 12 also provides mathematical equations for determining the relationship between the boom weight and the weight of the counterweight.

Environmental Protection

The dashpots and adjacent structures could be exposed to a wide range of environmental temperature influences varying from direct sunlight at +44°C ambient temperature to impingement by liquid oxygen boiloff gas at -180°C from the vehicle. Such extreme variations would have a significant effect on design and final costs. To provide a more controlled, consistent environment, the end of the system nearest the vehicle has a tubular frame around it, over which is stretched a covering made of chloroprene coated nylon fabric. This covered area is continuously purged with ambient air supplied from a centrifugal blower mounted on the umbilical tower. Thus the dashpots, mechanism, and structure within the covered section are maintained at ambient temperature.

RETRACTION SYSTEM

Retraction System Description

It was decided early in the design to provide a system which would give an "instantaneous" clearance of about two feet between the boom and the vehicle with an ever-increasing, but slower, clearance build-up between two feet and nine feet. The retractable arms mechanism shown in figure 13 accomplishes the instantaneous two-foot clearance portion. The retractable arms mechanism consists of two pivoted, springloaded arms, three spring, cable, and pulley assemblies, a crosshead on which the arms pivot and the afore-described attach pin. The two to nine-foot portion of the clearance is provided by separating the cable which supports the support boom and allowing the boom to freely swing about its hinges until it engages a snubber mechanism. When the release mechanism, located as shown in figure 2, separates the cable, the counterweight is also released. The counterweight falls approximately 15 cm where it is stopped by two small shock absorbers.

The sequence of retraction is for the vehicle to begin to liftoff, the boom/damper mechanism assembly accelerates up with the vehicle until limited by a restraint chain, at which time the pin is pulled releasing the arms to provide a two-foot clearance. Simultaneous with vehicle rise, an electrical signal is sent to the boom release mechanism which separates the cable into detached parts as shown in figure 14, permitting the boom and counterweight to fall by gravity, independently. The boom falls onto the snubber mechanism provided to absorb the energy in the falling boom.

Retractable Arms Mechanism

The retractable arms mechanism (figure 13) is made up of two pivoted arms. The left hand arm is one-piece. The right hand arm is pinned to a pivoting link about one-third of its length. This pivoting link is adjacent to, and in parallel with, a fixed section of the right hand arm so that, when the arm is extended and the attach pin (figure 3) is inserted through the outboard arm bushing, the pin engages the fixed section, in effect bypassing the pivoting link out of the system. When the pin is engaged through the bushing far enough to engage the rigid portion of this arm, then the "four bar" linkage becomes a rigid triangle. However, as the vehicle rises and the pin disengages from the rigid portion of the right hand arm, this arm becomes articulated around the pivot link. The right arm is retracted by the double springs shown, whereas the left arm is retracted by being pulled in by the right hand arm and by the single spring. When retracted, the arms nest together and are latched tightly against the crosshead to prevent centripital force from extending them as the boom retracts.

0
C
E

The arms are machined from 17-4 PH steel billets and are shaped primarily by a stiffness requirement in reacting the dynamic (vertical) preload. The crosshead is a built up, box-reinforced channel made of A36 steel. A small shock absorbing rubber washer on the end of the arms, concentric with the outboard pivot bushing, is installed between the arms and the attach pin support housing as seen in figure 3. The washer is provided to dampen out any higher frequency vibrations and prevent shock loading between the arms and the attach pin housing. The washer is hard silicon rubber with cupped metal washers protecting its flat contact surfaces. The washer-cup assembly is fastened to the left arm by screws.

Release Mechanism

Figure 14 shows the boom release mechanism. This mechanism is in the vertical run of cable between the boom and the counterweight. Its purpose is to separate the cable upon command to permit the boom to drop. The mechanism consists of an upper plate, lower block, two clamping blocks, and two explosive bolts. The upper plate is attached to the lower end of the vertical cable run. At the lower end of the upper plate is an enlarged, triangular, wedge-shaped section. This wedge-shaped section is held hard against the lower block by the two clamping blocks as shown. The lower block is attached to the counterweight by a steel rod. The explosive bolts each hold one clamping block to the lower block. The explosive bolts each have redundant squibs and are fired by redundant circuits activated by redundant switches in the launcher system which releases the vehicle for launch. Thus, the release of the ground wind damper system is not initiated until the vehicle has been committed to launch. Firing of either squib in either bolt releases a clamping block which permits the wedge-shaped portion of the upper plate to come free. The released clamping blocks are retained by wire rope cable tethers to the lower block.

When the release mechanism is fired, the upper plate is freed. The cable runs over the pulley, permitting the boom to drop against its snubber. It also releases the counterweight which drops down about 15cm, guided by two tracks onto two shock absorbers. To "recock" the release mechanism for the next launch, a hand winch lifts the boom back out to its horizontal position and a hand-jacking system raises the counterweight back to its operating position. The release mechanism can again be assembled. Set-up bolts and straps are used to hold the release mechanism together until the explosive bolts are installed on launch day. At this time, the set-up bolts and straps are removed.

Snubber Mechanism

As stated earlier, when the boom is released it falls onto a snubber mechanism which absorbs the energy of the fall. The snubber mechanism decelerates the boom at approximately 5 g's to protect the damper mechanism at the end of the boom from high side loads. Figure 15 shows the snubber mechanism. It consists of a 0.5 meter stroke shock absorber end-mounted in a housing which also forms the trunnion mount for a large bellcrank. The rod of the shock absorber is attached to the short arm of the bellcrank. A pair of rollers is mounted on the long arm of the bellcrank. On the outboard end of the boom there is an elliptical ramp which contacts these rollers when the boom has fallen to the point where it must be decelerated. The elliptical shape of the ramp was required to gently initiate motion in the bellcrank. Tests performed with a flat plate ramp produced high impact loads as the boom energy was transferred into the bellcrank to start it and the shock absorber piston in motion. Rotation of the bellcrank causes displacement of the oil in the shock absorber through orifices to absorb the 2.03×10^5 N-m of kinetic energy developed by the falling boom mass.

As the boom falls it engages a spring loaded latching arm. The arm has three barbs, any of which prevents boom rebound by trapping a catch bar mounted on the boom. The reason for multiple barbs is to restrain the boom in the farthest retracted position to which it might fall.

CONCLUDING REMARKS

The effectiveness of the Atlas/Centaur damper system was first demonstrated during a propellant tanking test of the Mariner 10 backup vehicle designated AC-33 in October 1973. A comparison of resultant rate gyro data from an undamped AC-26 vehicle and from AC-33 under similar ground wind conditions is shown in figure 16. The rate gyro signals shown are the resultant of vehicle pitch rate and yaw rate near the upper end of the Atlas. It is the most effective means of monitoring ground wind induced vehicle oscillations. In this case, the launch of AC-26 was delayed because of ground wind. The tanking test of AC-33 was completed in a routine manner.

The damper system successfully supported the launch of Mariner 10 on 2 November 1973. The existence of this system will provide considerable launch availability and launch safety improvements for Atlas/Centaur plus the capability for future growth in length.

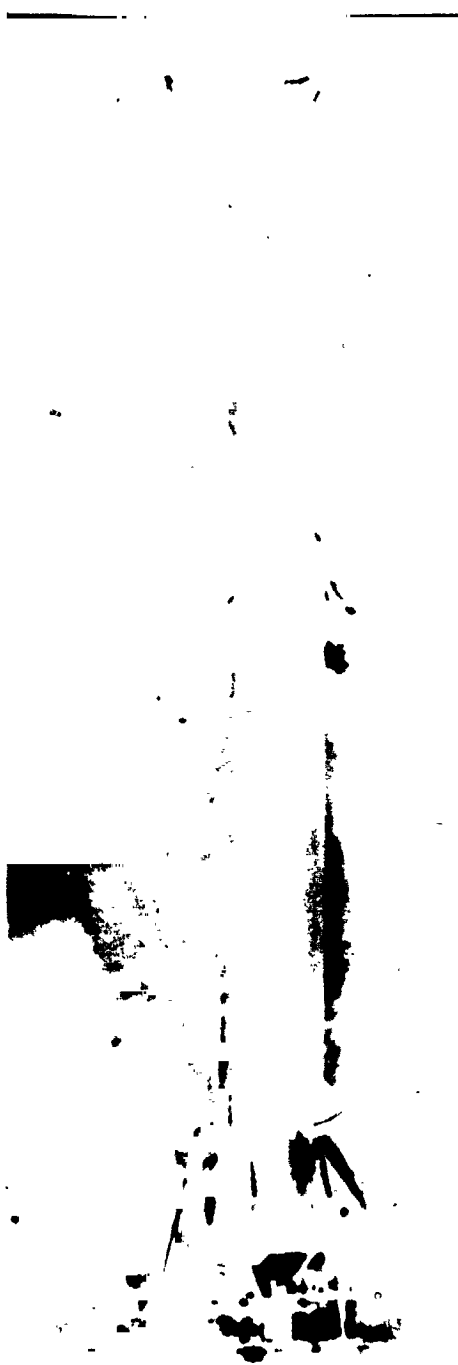
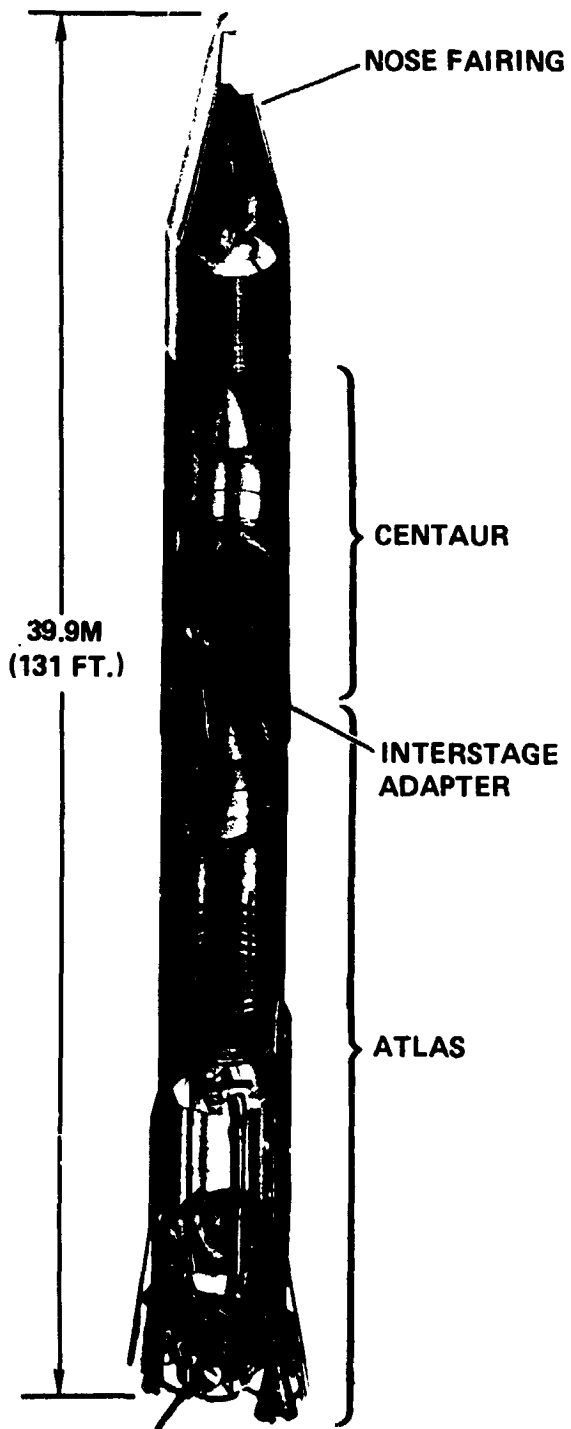

ATLAS/CENTAUR/INTELSAT IV

LIFTOFF FOR VENUS AND MERCURY NOVEMBER 1973

Figure 1. Atlas/Centaur launch vehicle.

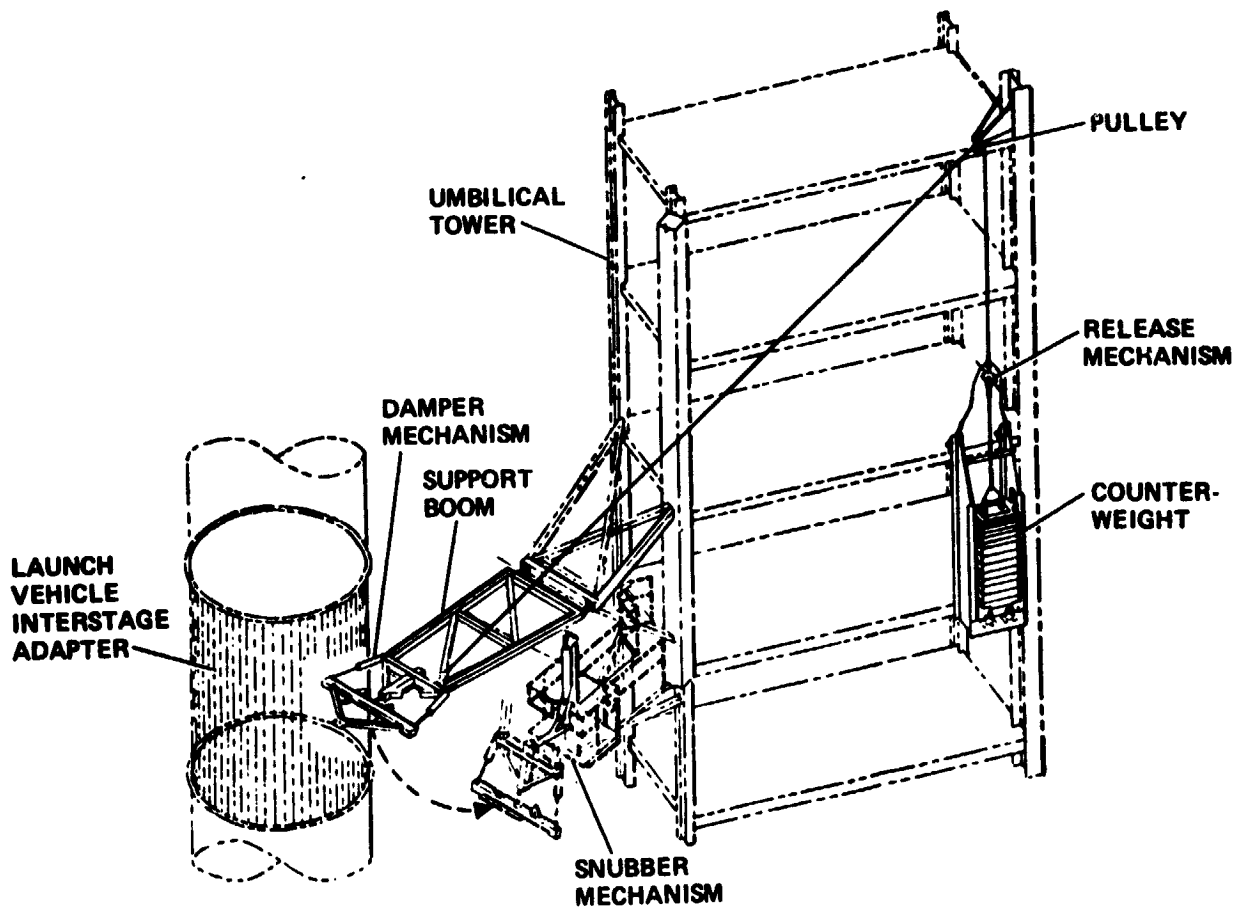

Figure 2. Installed ground wind damper system.

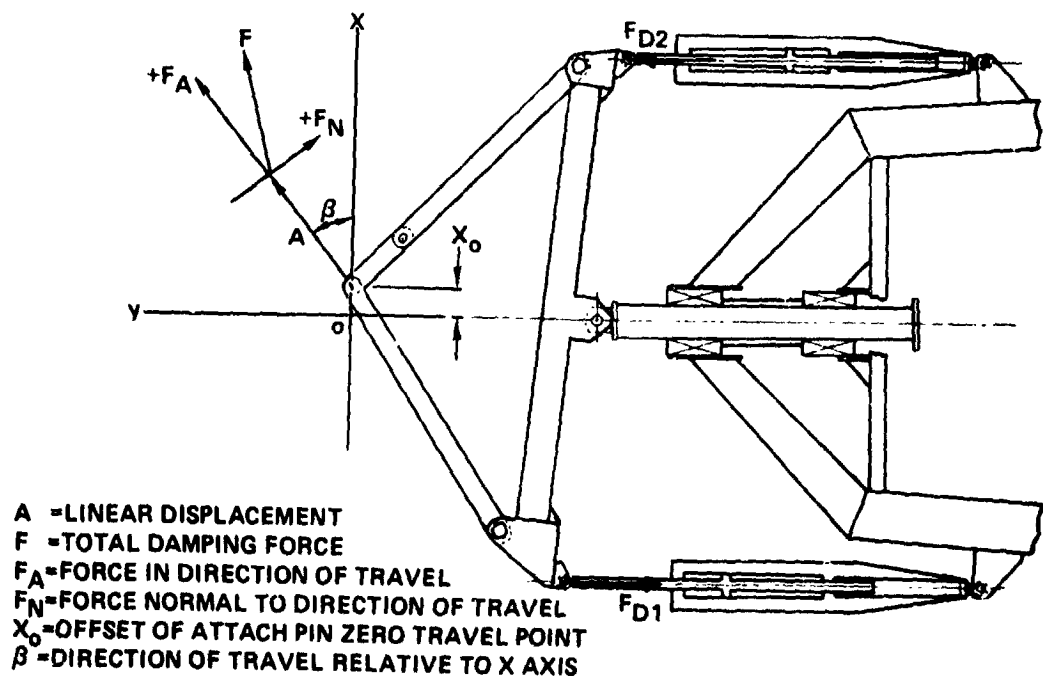
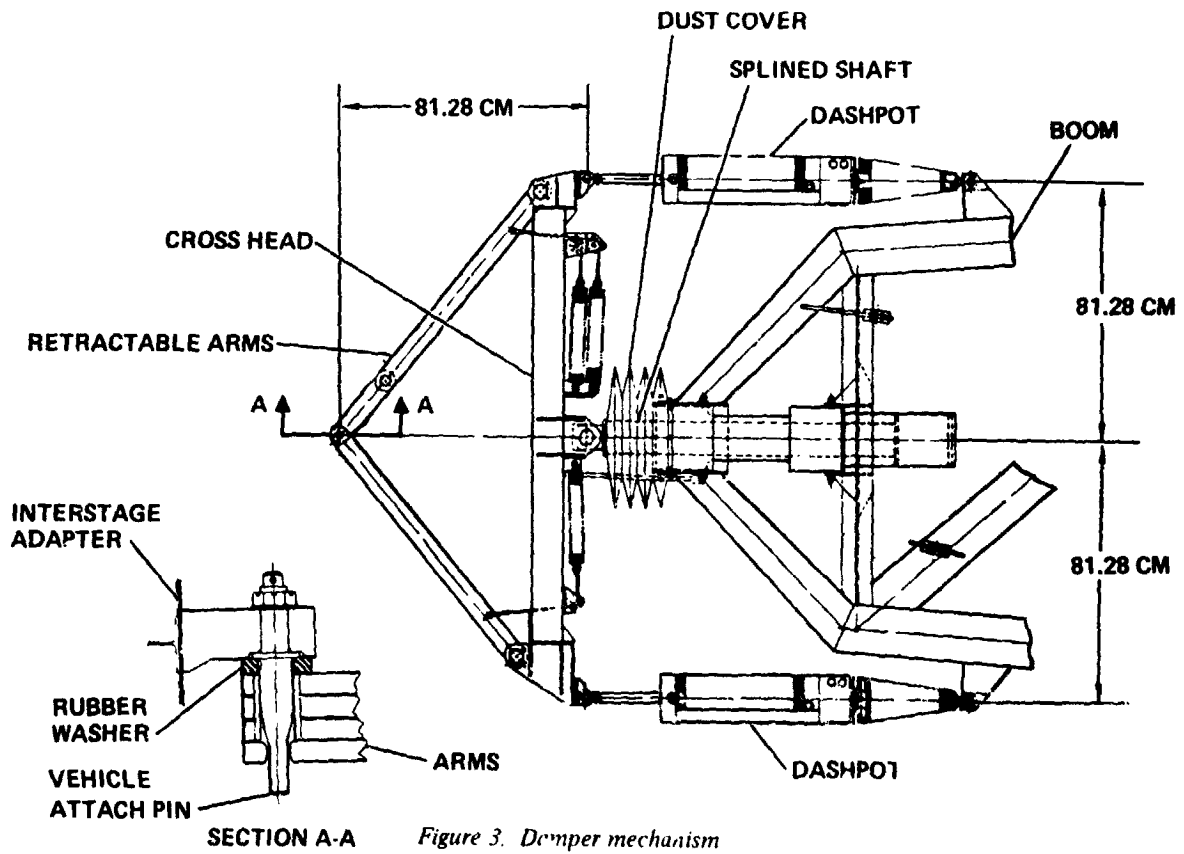

Figure 4. Damper force response to attach pin displacement.

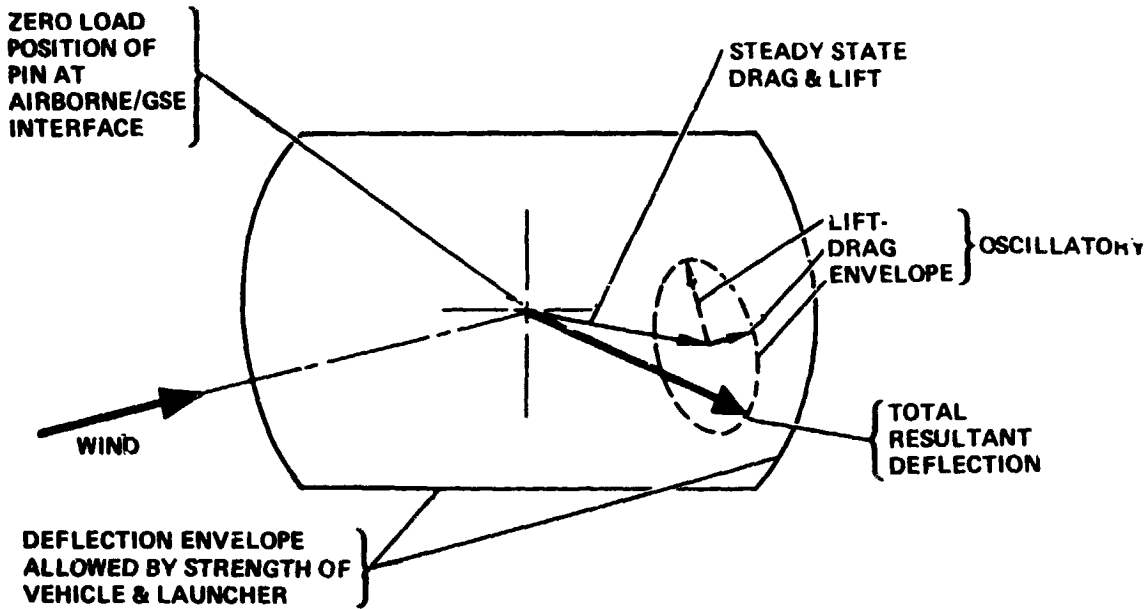

Figure 5. Illustrative description of vehicle deflections.

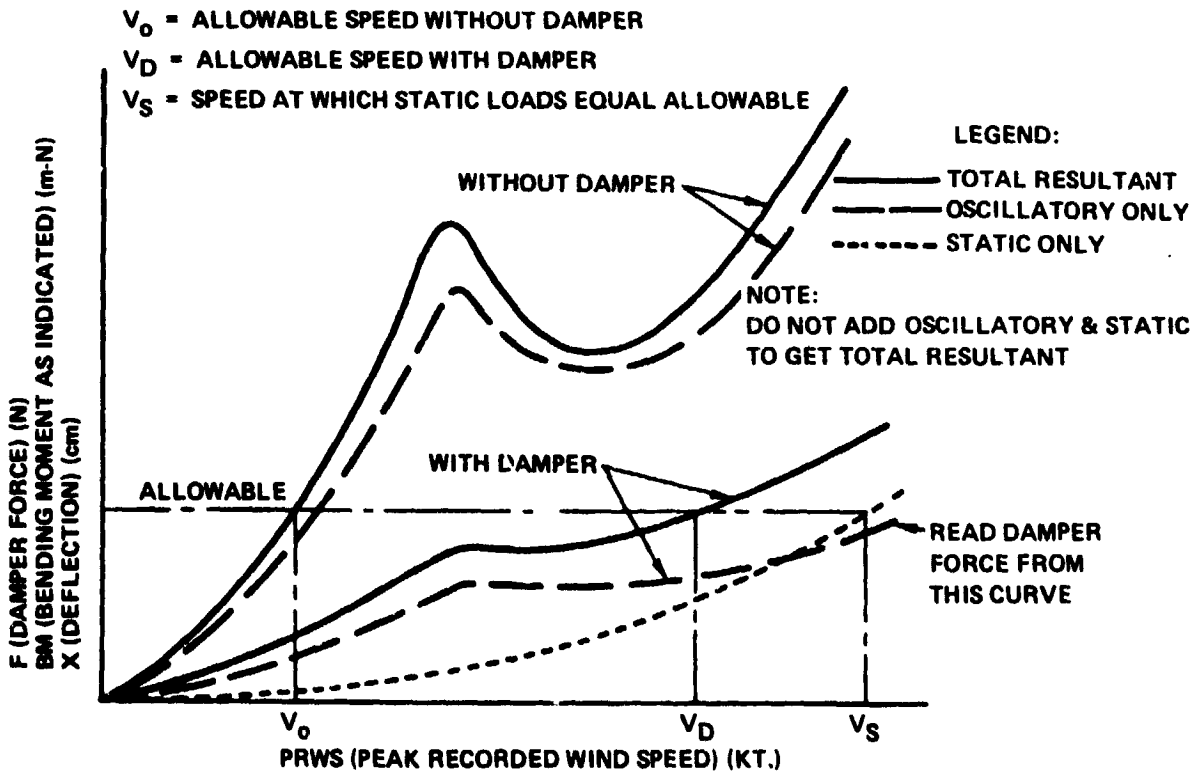

Figure 6. Characteristics of ground wind loads.

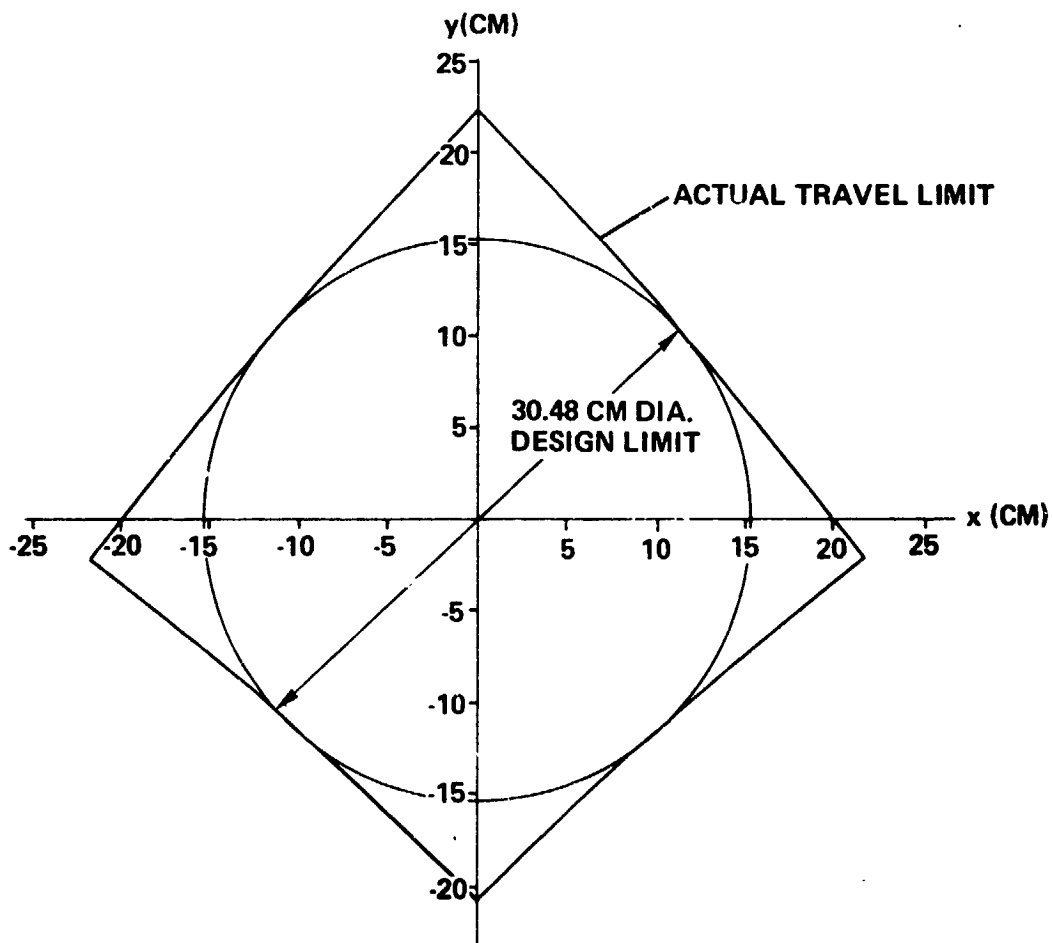

Figure 7. Damper mechanism travel limit.

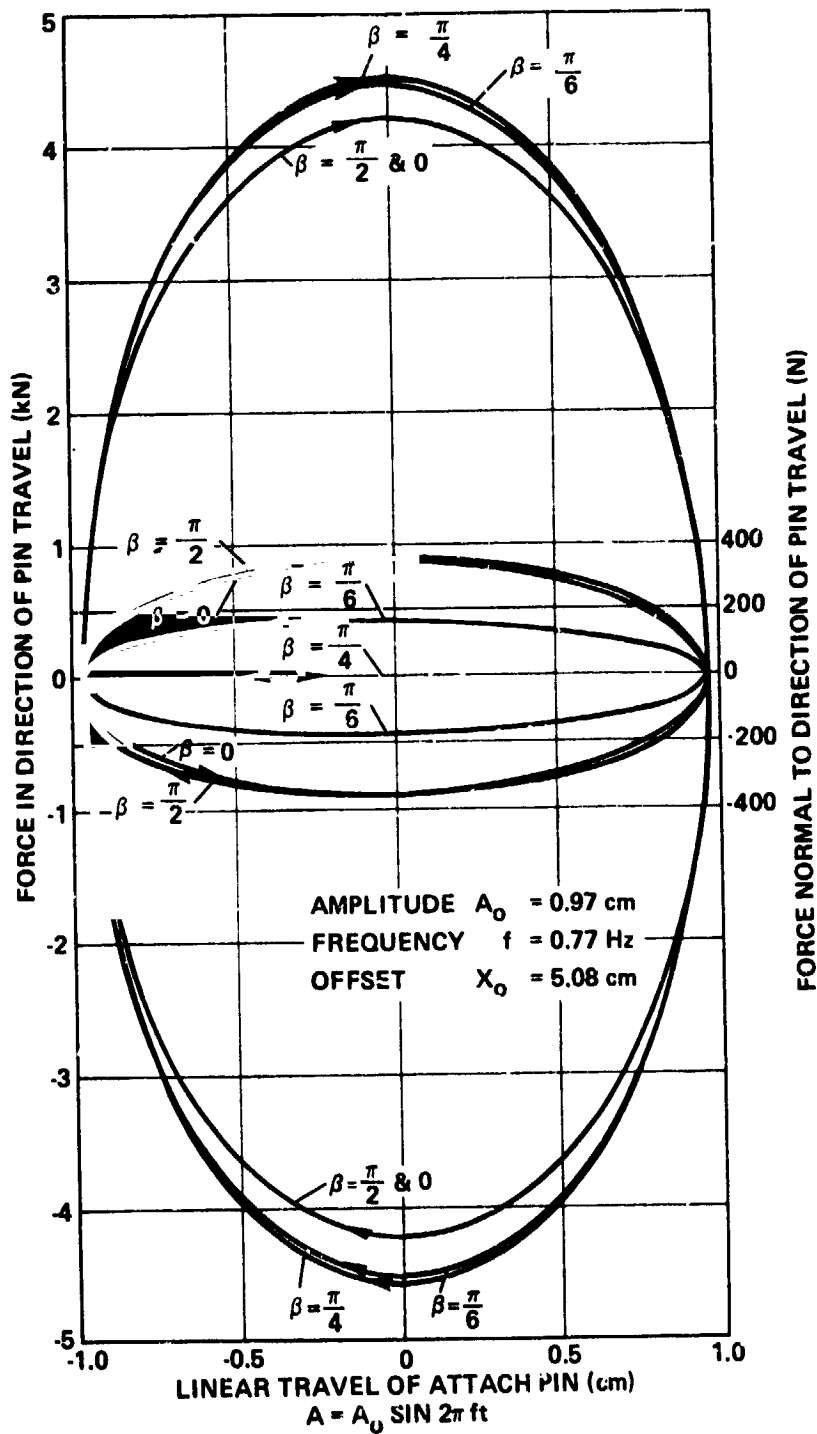
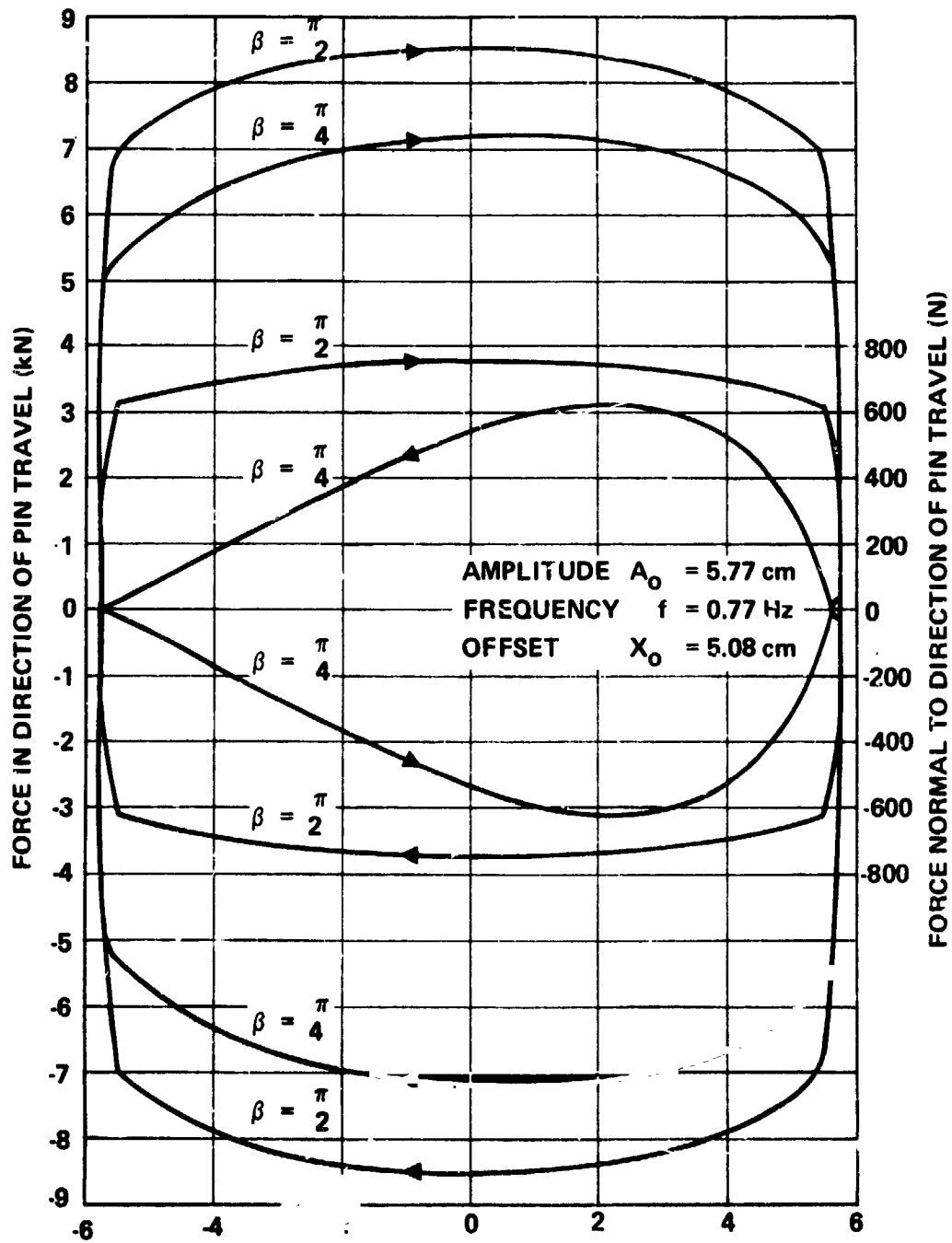

Figure 8. Proportional damping range force dispersions.



LINEAR TRAVEL OF ATTACH PIN (cm)
 $A = A_0 \sin 2\pi ft.$

Figure 9. Force limiting range force dispersions.

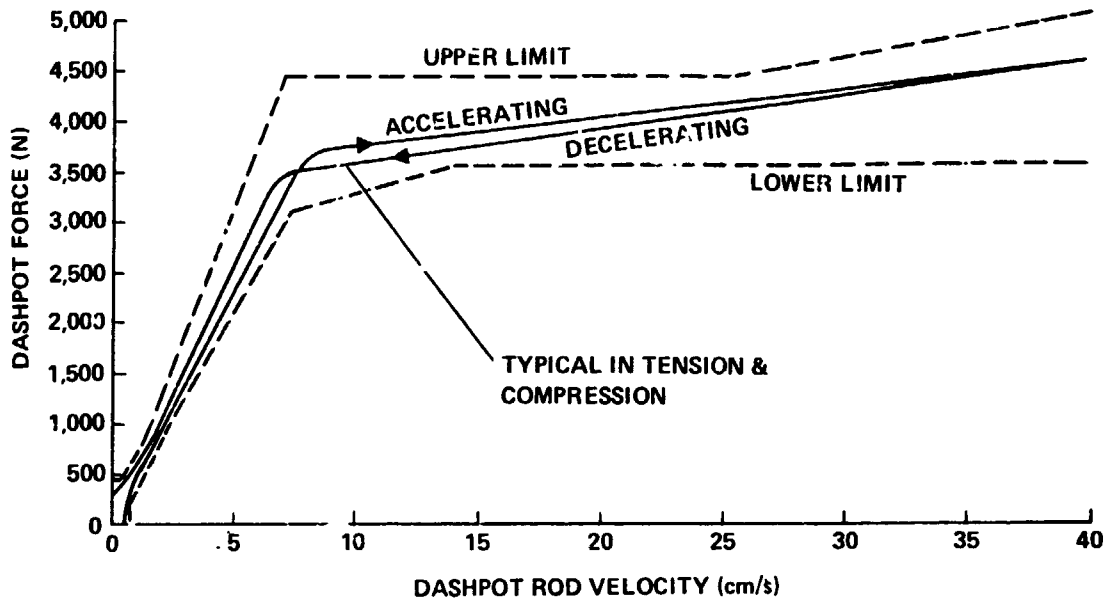

Figure 10 Dashpot damping characteristics

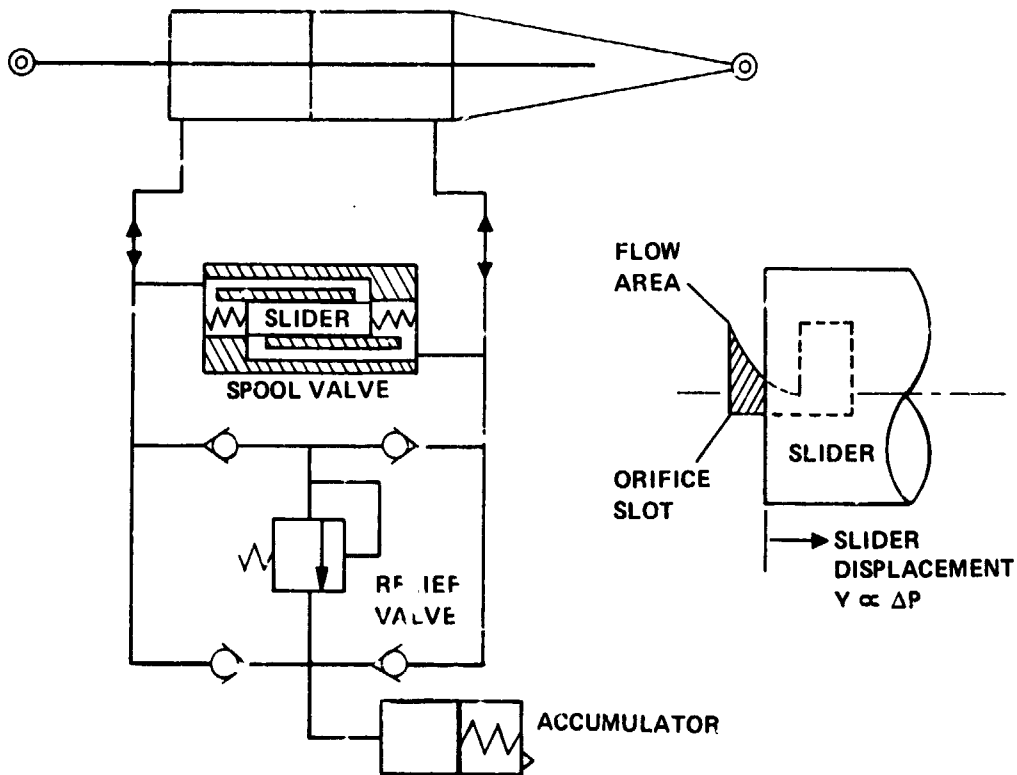
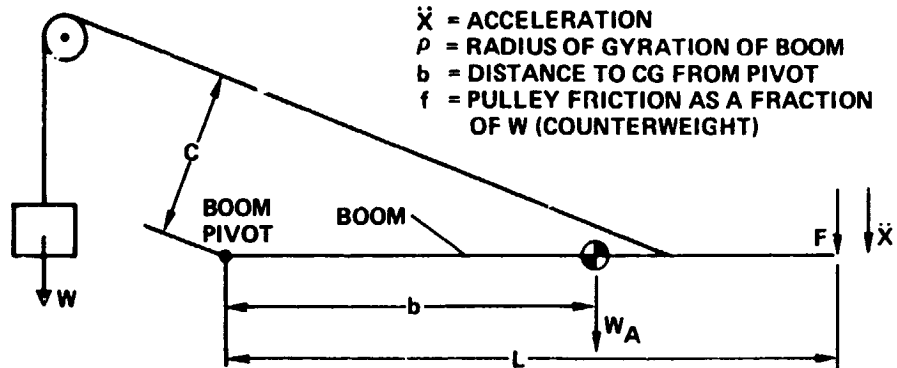

Figure 11. Dashpot schematic diagram.



REQUIREMENT: BOOM TIP ACCELERATE UP AT $1g$ WHEN FORCE F IS REMOVED.

WEIGHT OF COUNTERWEIGHT

$$W = \frac{W_A (Lb + \rho^2)}{CL(1-f) - C^2}$$

FORCE REQUIRED TO ACCELERATE END OF BOOM DOWN AT $1g$

$$F = \frac{WC(1-f) - W_A b}{L} + \frac{\ddot{X}}{gL^2} (W_A \rho^2 + WC^2)$$

Figure 12. Boom acceleration calculation.

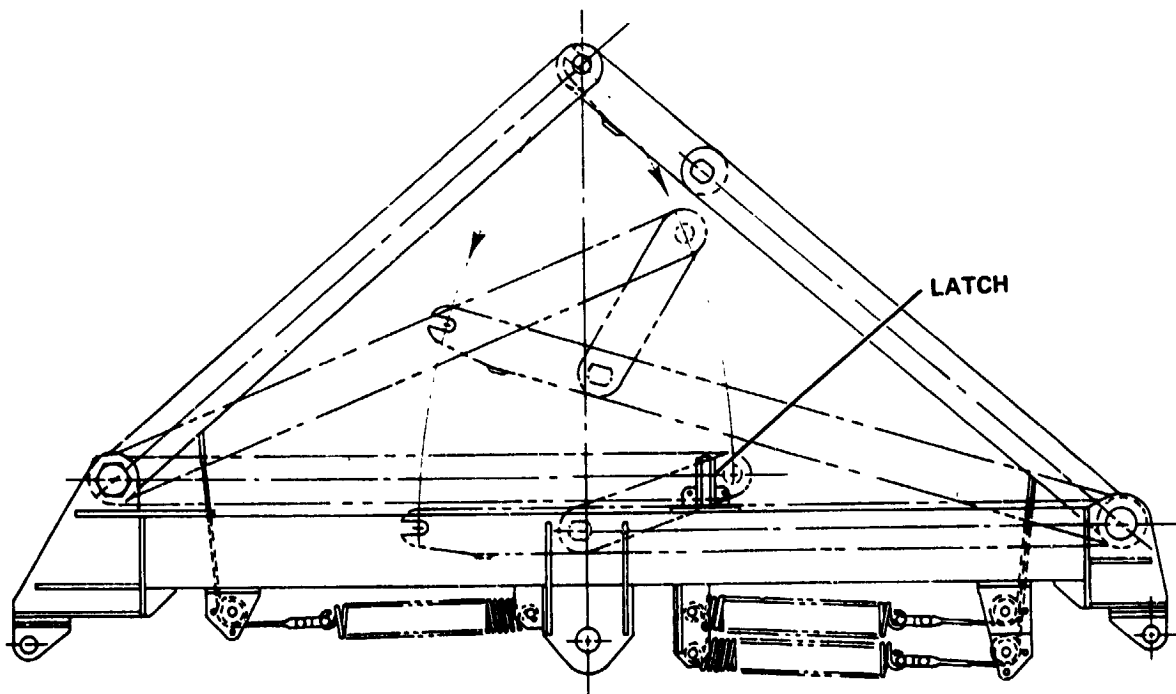

Figure 13. Retractable arms mechanism.

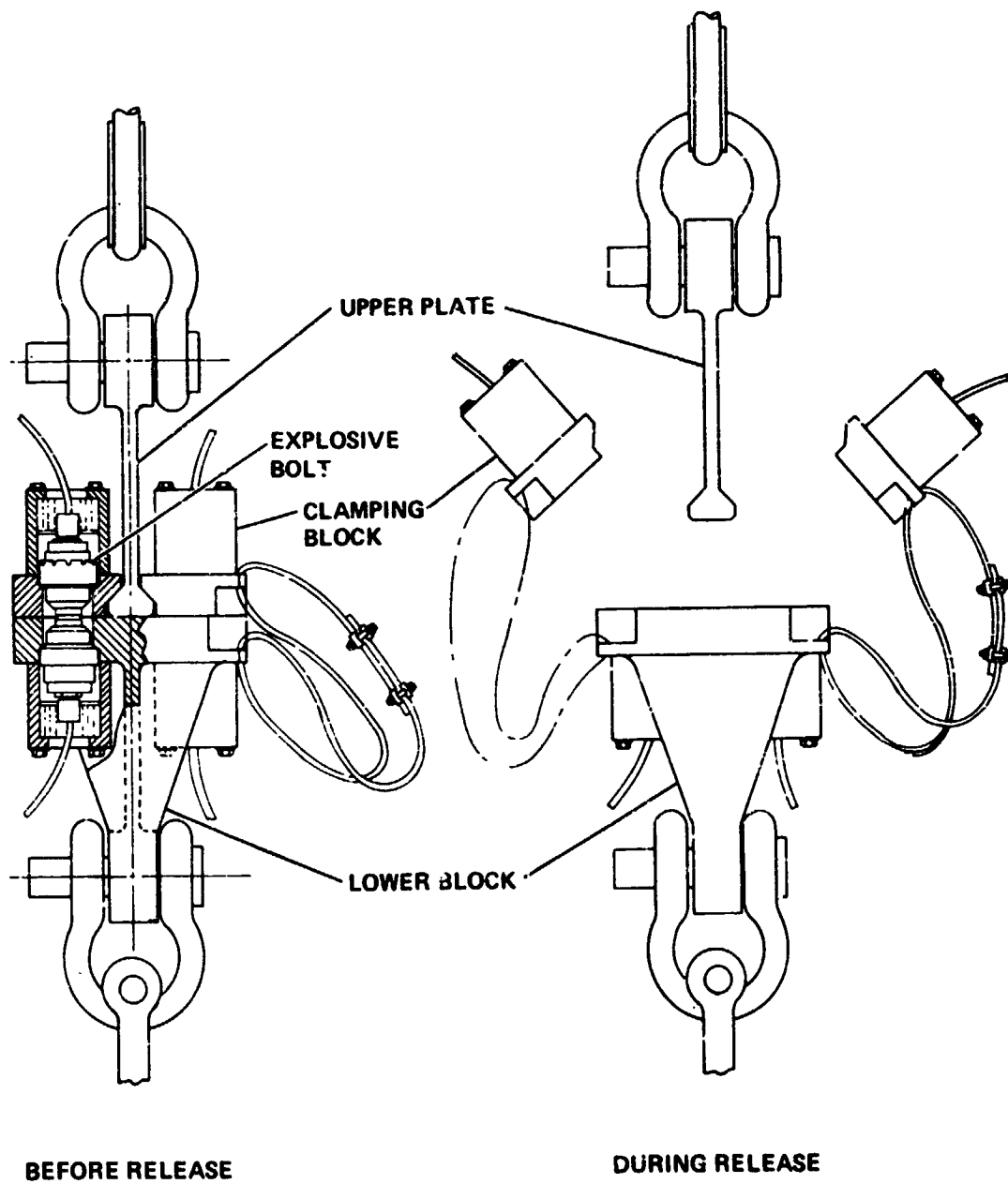

Figure 14. Boom release mechanism.

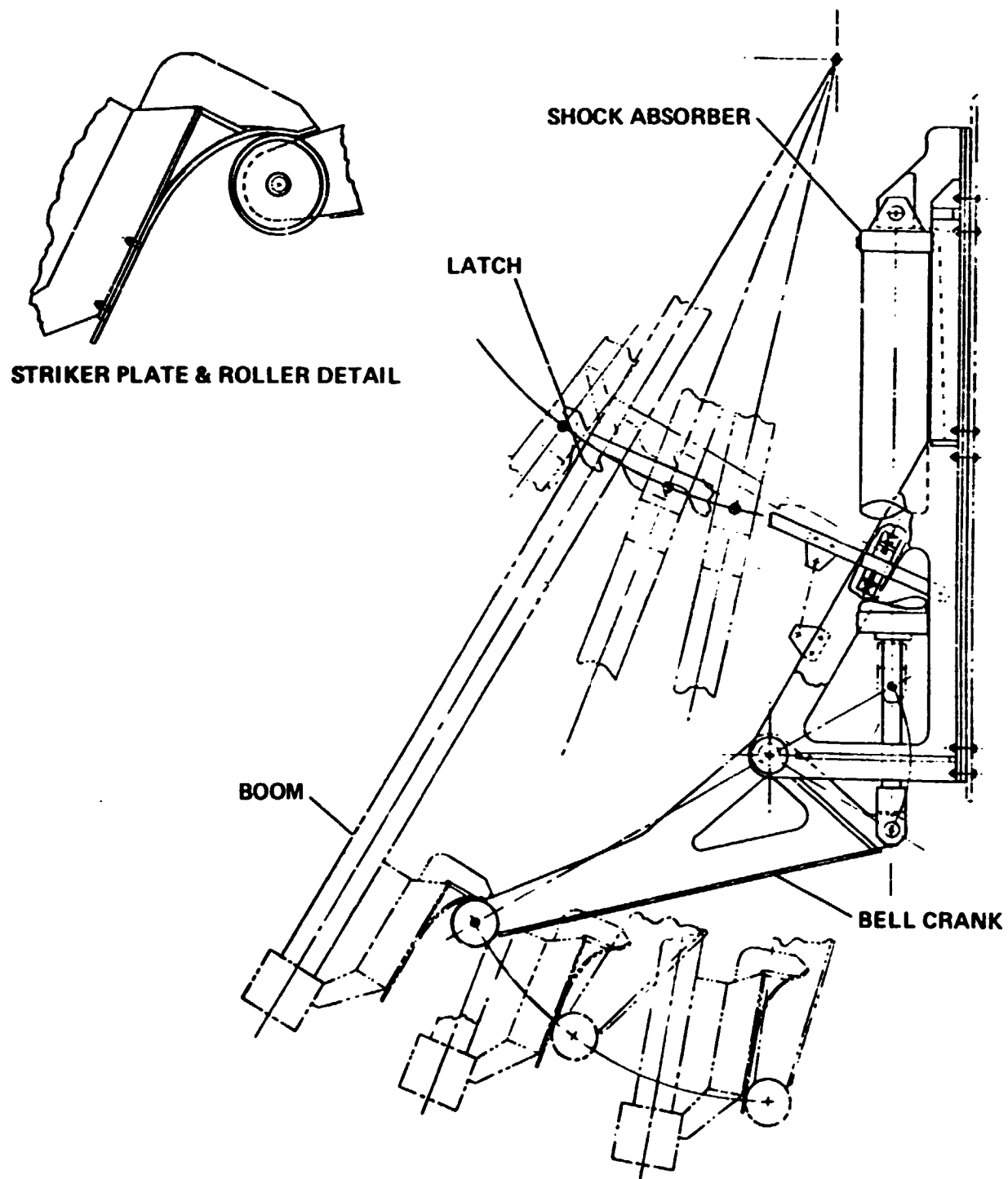
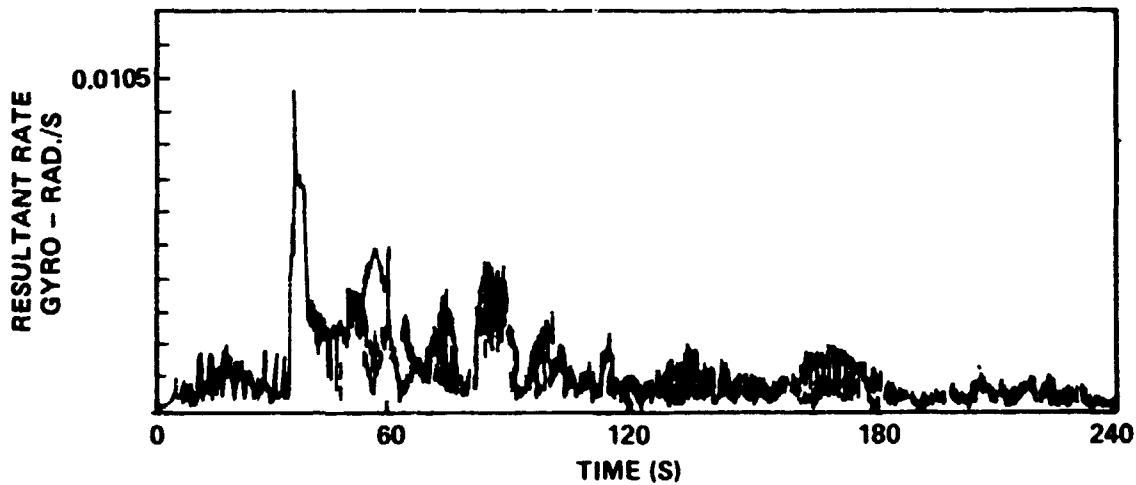
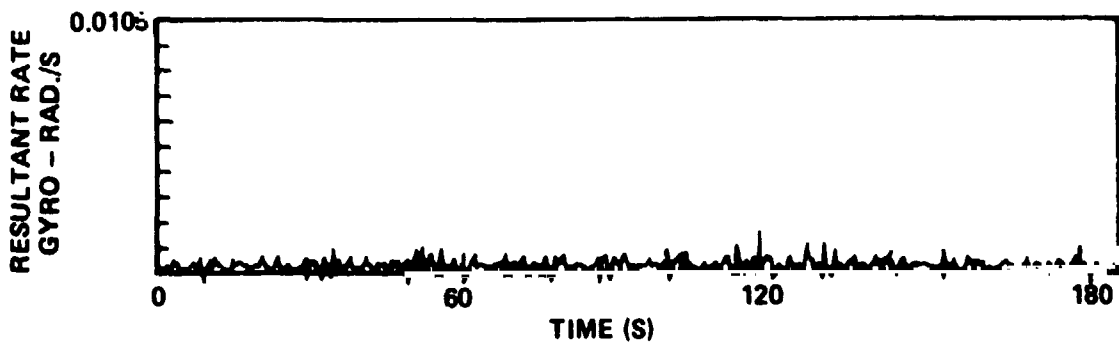
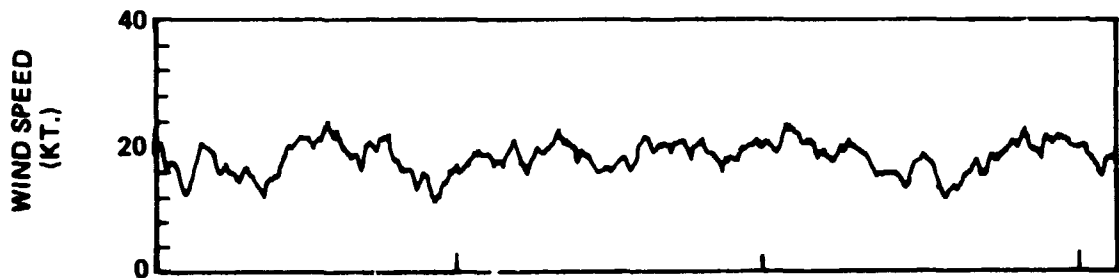

Figure 15. Snubber mechanism.



AC-26 VEHICLE, NO DAMPER, NORTH WIND, ATLAS FUELED ONLY



AC-33 VEHICLE, WITH DAMPER, NORTH WIND, ATLAS FUELED ONLY

Figure 16. Results of damper installation.