

N76-19197

25. MOUNT MECHANISMS

FOR THE SATURN V/APOLLO MOBILE LAUNCHER

AT JOHN F. KENNEDY SPACE CENTER

By Harry A. Balke

Harry Balke Engineers, Cincinnati, Ohio

SUMMARY

The expanse of the mobile launcher (ML), its operational requirements, and the environmental extremes to which it is subjected presented a difficult problem in providing it with a suitable support system. Since the crawler transporter had to pass beneath the ML to lift it for travel, the supports had to be a minimum of 6.7 meters (22 feet) above ground level with a transverse spread of 40.5 meters (133 feet). The support system had to resist hurricane wind loads at the launch pad and yet allow the supported structural frame to expand and contract freely under wide ranges of temperature. Such a support system was conceived and designed by the author. This system consists of six mount mechanisms (Types I through III), devised to meet the previously stated requirements plus a load-carrying capacity for each of 3.2-million kilograms (7-million pounds) downward and 1.6-million kilograms (3.5-million pounds) upward. A similar but lighter system of six mount mechanisms (Types IV through VI) were designed for use in the sheltered environment of the Vehicle Assembly Building (VAB). Each requirement and design result is discussed in the text, and each mount mechanism by location and type is defined with references to visual presentations.

INTRODUCTION

The launch pad, ML erection area, and VAB mount mechanisms function to support the ML and to provide clearance for the crawler transporter to pass beneath the ML. Six mount mechanisms at the launch pad support the weight of the ML and the unfueled Saturn V vehicle and accommodate those horizontal and vertical loads imposed by wind and thermal expansion. Prior to fueling, four extensible columns are placed in position to minimize the rebound effect of the ML at launch vehicle release during firing. Mount mechanisms at the erection area are similar to those at the launch pad. The VAB must be utilized in the event of impending hurricane winds when the launch vehicle is erect on the ML. Foundations at the erection area are designed for hurricane wind loads, but the VAB provides an enclosure for the ML and vehicle, reducing the foundation requirements there. The six types of mount mechanisms with their mating process are discussed in the following text. Since the mount mechanisms always mate with the ML base, the structural makeup of the ML is discussed first to explain the need for different types of mount mechanisms.

MOBILE LAUNCHER

The ML (see figure 1) is basically a huge box-like platform 40.5 meters (133 feet) wide, 48.2 meters (158 feet) long, and 7.6 meters (25 feet) deep, and structurally symmetrical about its longitudinal axis. It supports a 115.8-meter (380-foot) umbilical (service) tower at one end and furnishes support for the vertical launch vehicle 24.4 meters (80 feet) from the tower's transverse centerline. The platform has six primary supports--three mount mechanisms under each of the outside longitudinal girders. Both outside girders are supported at each end and centrally at their intersections with the main transverse girder. This girder supports the inboard legs of the tower 18.3 meters (60 feet) from the end girder that supports the outboard legs. The space between the two rows of mount mechanisms, which are 6.7 meters (22 feet) high, allows clear passageway for the crawler transporter to pass beneath the ML to lift it for travel (see figure 2).

MOBILE LAUNCHER (BASE) DESIGN

The basic ML structural frame is rectilinear, consisting of five main girders, nominally 7.6 meters (25 feet) deep. Two outside girders are 48.2 meters (158 feet) long, framed between two end girders, 40.5 meters (133 feet) long. The fifth main girder is interior and located 18.3 meters (60 feet) from one end girder and parallel to it. One mount mechanism support point is located at each corner with a central support at each intersection of the interior girder and outside girders.

SUPPORT COLUMN ASSEMBLY DESIGN

For horizontal control of the ML's expansion and contraction, three types of support column assemblies were designed, which, to distinguish them from more conventional supports, were designated "Mount Mechanisms, Type I, Type II and Type III." With reference to the horizontal plane of support, the Type I is fixed, the Type II allows freedom of movement either laterally or longitudinally but fixed in the other direction, and the Type III allows freedom of movement in both directions (see figure 2).

The various types of mount mechanisms are installed so that one side girder and the interior girder are fixed laterally, but free to expand and contract longitudinally with relation to their common intersection, which is fixed in the horizontal plane. The opposite side girder is fixed longitudinally at its intersection with the interior girder because the interior girder is fixed laterally. The opposite side girder is free to expand and contract longitudinally from that intersection in the direction of its intersections with the two end girders. These intersections are free to move in any horizontal direction, as the opposite ends of the end girders intersect at the side girder which is

fixed laterally. With this support system, the ML is stable and yet allowed to expand or contract without inducing secondary stresses into the girder system.

MOUNT MECHANISM DESCRIPTION

Type II Mount Mechanism (see figure 3) comprises an adjustable 914-millimeter (36-inch) tubular column braced by an adjustable 457-millimeter (18-inch) tubular diagonal. The main shaft is 4.3 meters (about 14 feet) between centers of ball joints, created by 792-millimeter (30-inch) hemispherical bearings, allowing full articulation at each end. The centerline of the diagonal intersects the centerline of the column at the top center of rotation, connecting there with a pin and clevis joint. The diagonal forms a nominal one-to-one slope with the vertical shaft, ending with a 457-millimeter (18-inch) hemispherical bearing whose center of rotation is level with the bottom center of rotation of the main shaft. This arrangement allows the shaft and diagonal brace freedom to move only in a plane about the axis through these centers of rotation. Since relatively small movements are required for operational and environmental adjustments, the main shaft's top moves rectilinearly for all practical purposes.

Each ball joint consists of a hemispherical bearing and a yoke assembly. The yoke consists of an externally threaded forging which flares out into a spherical surface that forms the outer wall of the socket for the hemispherical bearing; all spherical surfaces are centered on the ball-joint center point. A collar, whose inner surface is spherical, fits over the outer wall of the bearing socket and is securely bolted to the flange with which each ball-joint end of the main shaft and diagonal is provided. This arrangement provides ball-joint action if the member is in tension or compression.

An internally threaded boss, flanged and drilled to bolt to the underside of the ML, is screwed onto the column's top yoke. The column's bottom yoke is screwed into an internally threaded boss, an integral part of the base plate assembly, which is bolted to the foundation. A similar system is used for anchoring the strut to the foundations.

Thus, the Type II Mount Mechanism, when bolted to the bottom of the ML, allows the connected point of the ML structure to rotate freely, in flexure, about the top ball joint and move horizontally perpendicular to the nominal column-strut plane but fixed against movement parallel to that plane. The following two types have the same basic design as the Type II but include features that affect the horizontal movement of its ML connection in a different manner.

Type I Mount Mechanism (see figure 4) is simply a Type II Mount Mechanism to which an additional strut has been added that lies in a plane 1.57 radians (90 degrees) in relation to the plane of the strut/column when it is vertical. The additional strut locks the top ball joint and also the connected point of the ML in position, allowing no horizontal movement but allowing freedom for the ML structure to rotate in flexure.

Type III Mount Mechanism (see figure 5) is a Type II Mount Mechanism without any side braces, allowing the connected point of the ML freedom to move in any horizontal direction and to rotate in flexure.

On every mount mechanism, minor features are included to assist operating personnel. A ladder is welded to each column shaft leading to a work platform from which the alignment of the mount mechanism with the ML support point can be observed and the securing bolts installed. Each column is provided with two column centering jacks for adjusting the top of the column horizontally. Where a column is stabilized with a strut, the corresponding centering jack is disconnected.

When the ML is moved by the crawler transporter to its position over the mount mechanism, the ML support points are very close to the centers of the mount mechanisms. A support point is seldom as much as 50 millimeters (2 inches) off center. The mount mechanisms are positioned to receive the 228-millimeter (9-inch) diameter shear pin protruding from the bottom of the ML at each connection point by adjusting the struts or column centering jacks before the ML is lowered onto the mount mechanisms.

Each mount mechanism is designed to carry its full load with the top ball joint 152 millimeters (6 inches) off center of the column base, longitudinally and laterally, simultaneously. Each mount mechanism (Type I, II, and III) is designed for vertical loads of 3.2-million kilograms (7-million pounds) downward and 1.6-million kilograms (3.5-million pounds) upward. The struts are designed for a full hurricane wind of 200 kilometers (125 miles) per hour on the ML, the wind velocity being based on that at the 10-meter (30-foot) level.

VAB MOUNT MECHANISMS

The VAB mount mechanisms are designed and located under the ML in a pattern similar to the outdoor mount mechanisms except they are lighter and simpler because of the greatly reduced loads to which they are subjected (see figure 6).

Type IV Mount Mechanism (see figure 7) is the VAB counterpart of Type I in that it allows no horizontal movement of the connected point of the ML structure but allows freedom for that point to rotate in flexure. To conserve space, the 6.7-meter (22-foot) mount mechanism is 1680 millimeters (66 inches) square in cross section, fixed to the foundation and with a ball joint only near the top. The yoke is flanged at the top for connection to the ML and rests directly on the hemispherical bearing that can be adjusted horizontally with the linear movement of a sliding plate system that rests on the column shaft. Two mutually perpendicular screws are used to slide the bearing surfaces of an intermediate plate and the flat surface of the spherical bearing in relation with one another until the ball joint is properly aligned under the ML connection point. Since uplift is no problem in the shelter of the VAB, Type IV Mount Mechanisms are designed only for compression loads up to 1.72-million kilograms (3.8-million pounds).

Type V Mount Mechanism (see figure 8) is merely a lighter and simpler version of Type II, designed only for compression loads up to 1.72-million kilograms (3.8-million pounds).

Type VI Mount Mechanism (see figure 9) is the lighter and simpler version of Type III, designed only for compression loads up to 950-thousand kilograms (2.1-million pounds).

A nominal wind of 85 kilometers (54 miles) per hour was considered as the basis for the horizontal load used to ensure the lateral stability of the ML in the VAB. This decreased horizontal loading allowed one less strutted Type V Mount Mechanism to be used and a Type VI to be used in its place (see figure 6).

CONCLUDING REMARKS

Since the mount mechanisms were designed to support the ML and vehicle at the VAB, the erection area, and the pads, the different environments and needs at each area necessitated different type mounts. Demands of space limitations, weight, and wind loading with some freedom of movement for positioning caused each type mount to be unique but universal in function. To allow for thermal effects of the ML base, positioning during ML and vehicle transfer, and vehicle vertical positioning, various mount movements and adjustments had to be designed into the mount mechanisms. This design has proven itself through many transfers and launches of the Saturn vehicle.

ACKNOWLEDGMENT

The author wishes to acknowledge the invaluable assistance of Mr. George Walter, NASA Design Engineering Directorate at Kennedy Space Center, Florida.

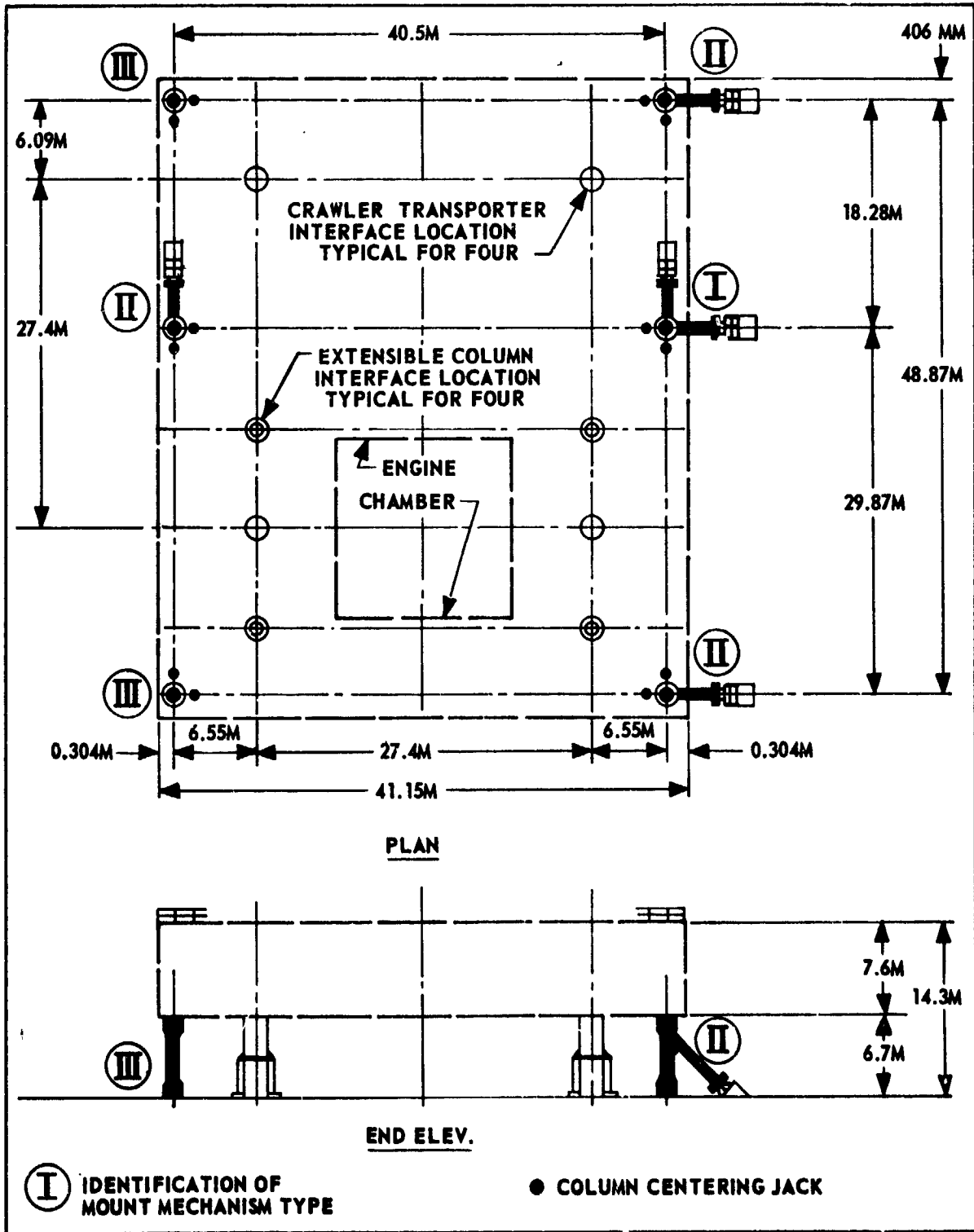
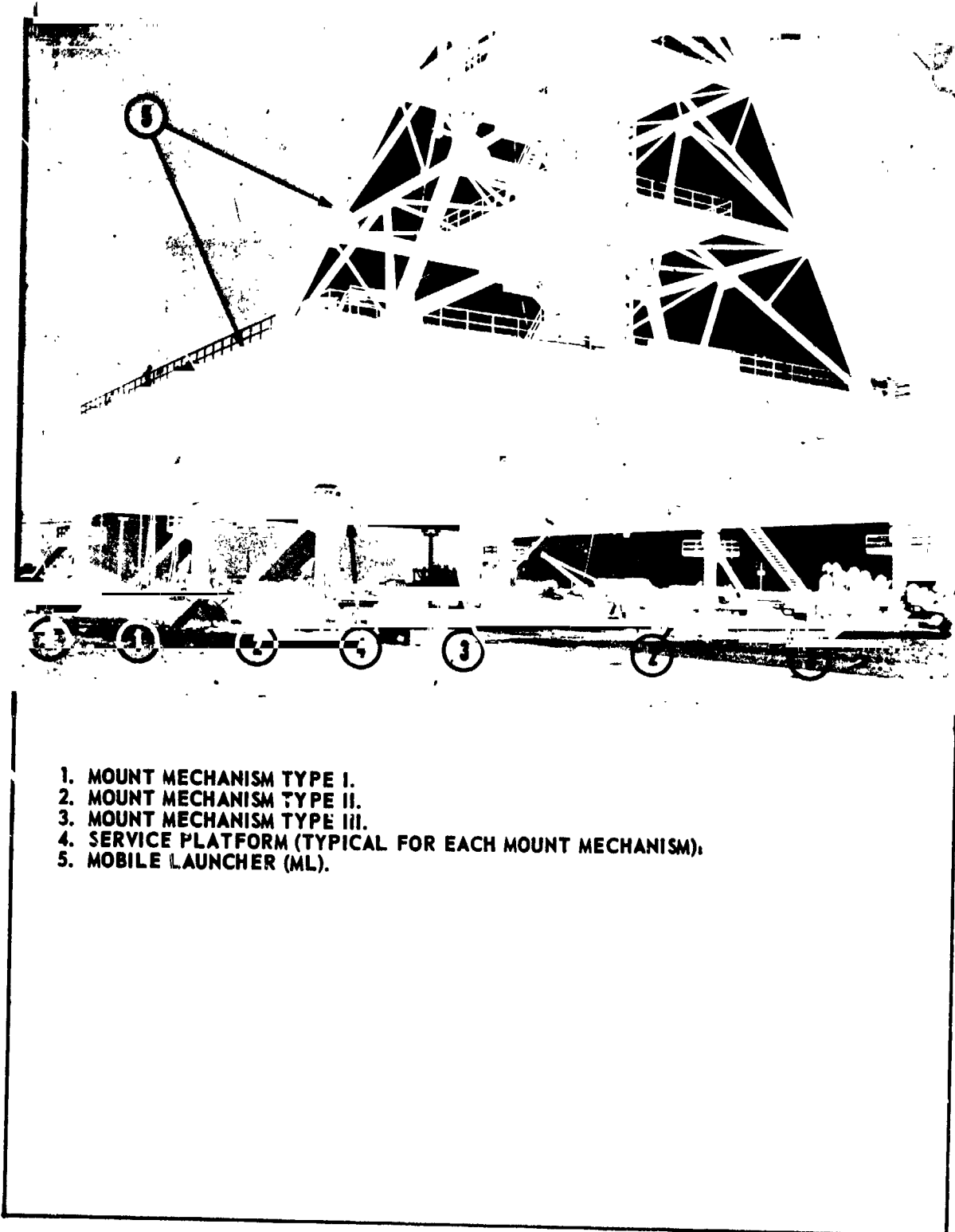

Figure 1. Mount Mechanisms - General Arrangement at the Launch Pad



1. MOUNT MECHANISM TYPE I.
2. MOUNT MECHANISM TYPE II.
3. MOUNT MECHANISM TYPE III.
4. SERVICE PLATFORM (TYPICAL FOR EACH MOUNT MECHANISM).
5. MOBILE LAUNCHER (ML).

Figure 2. Mount Mechanisms - General Arrangement in VAB

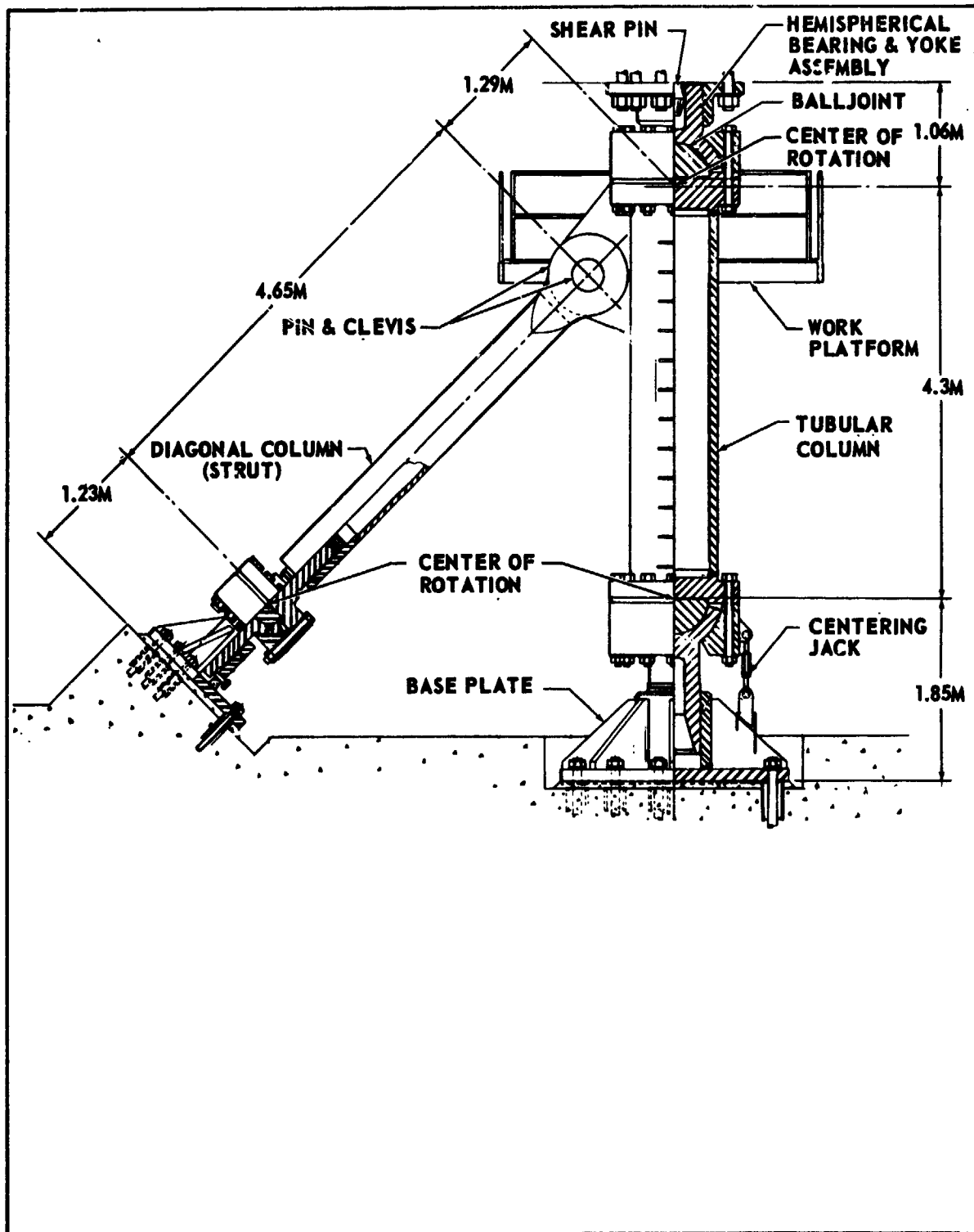

Figure 3. Mount Mechanism Type II With One Side Strut

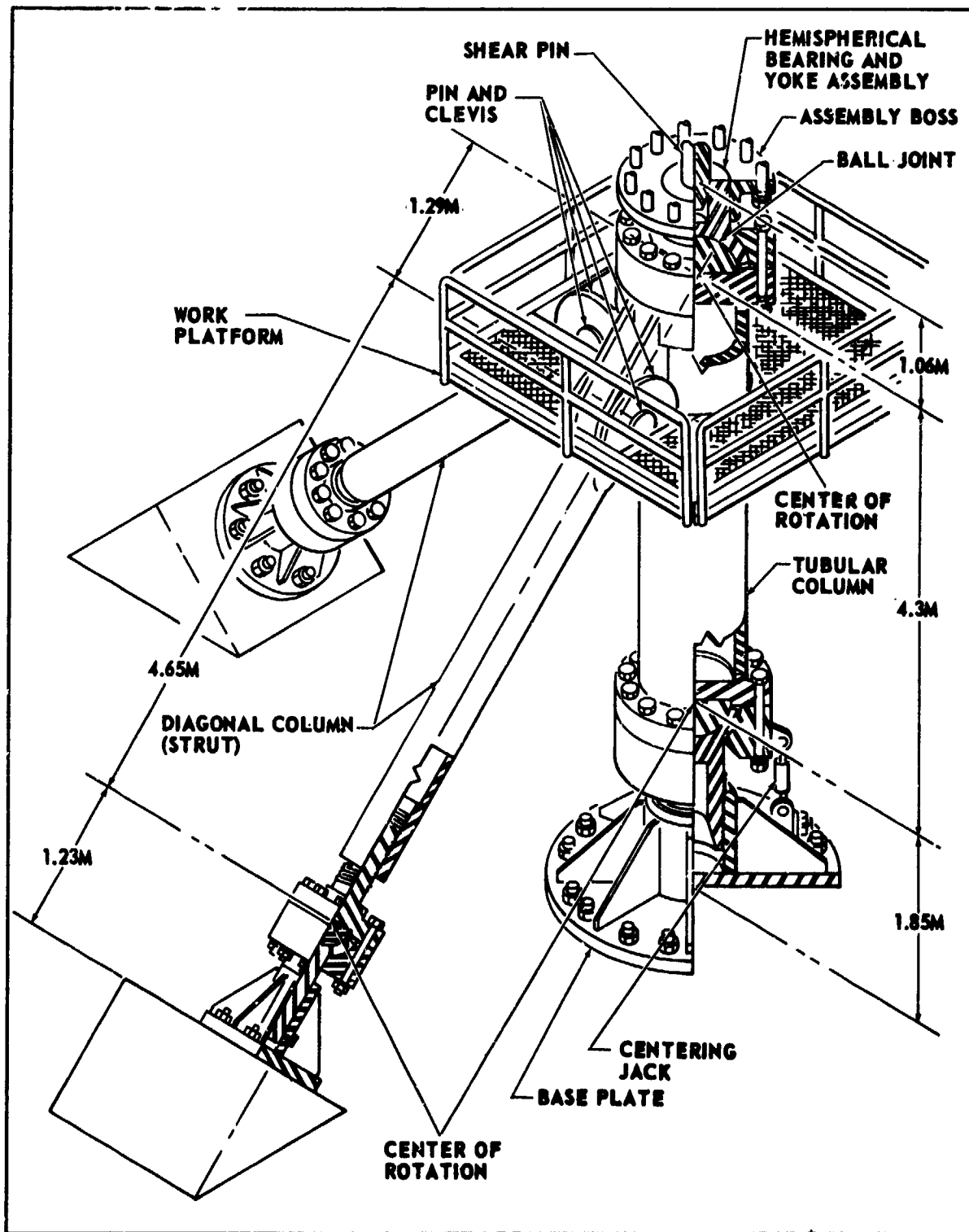

Figure 4. Mount Mechanism Type I With Two Side Struts

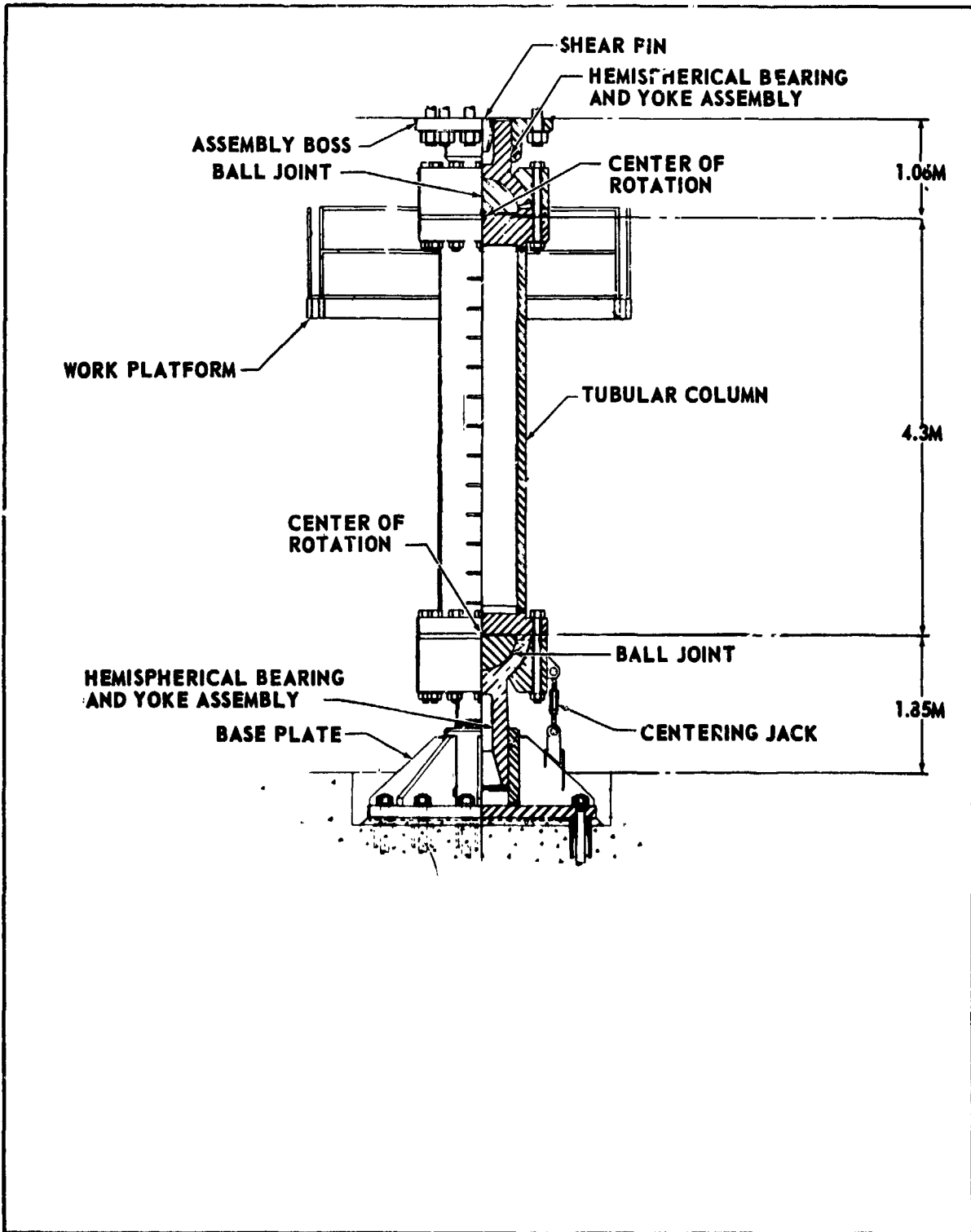

Figure 5. Mount Mechanism Type III Without Side Strut

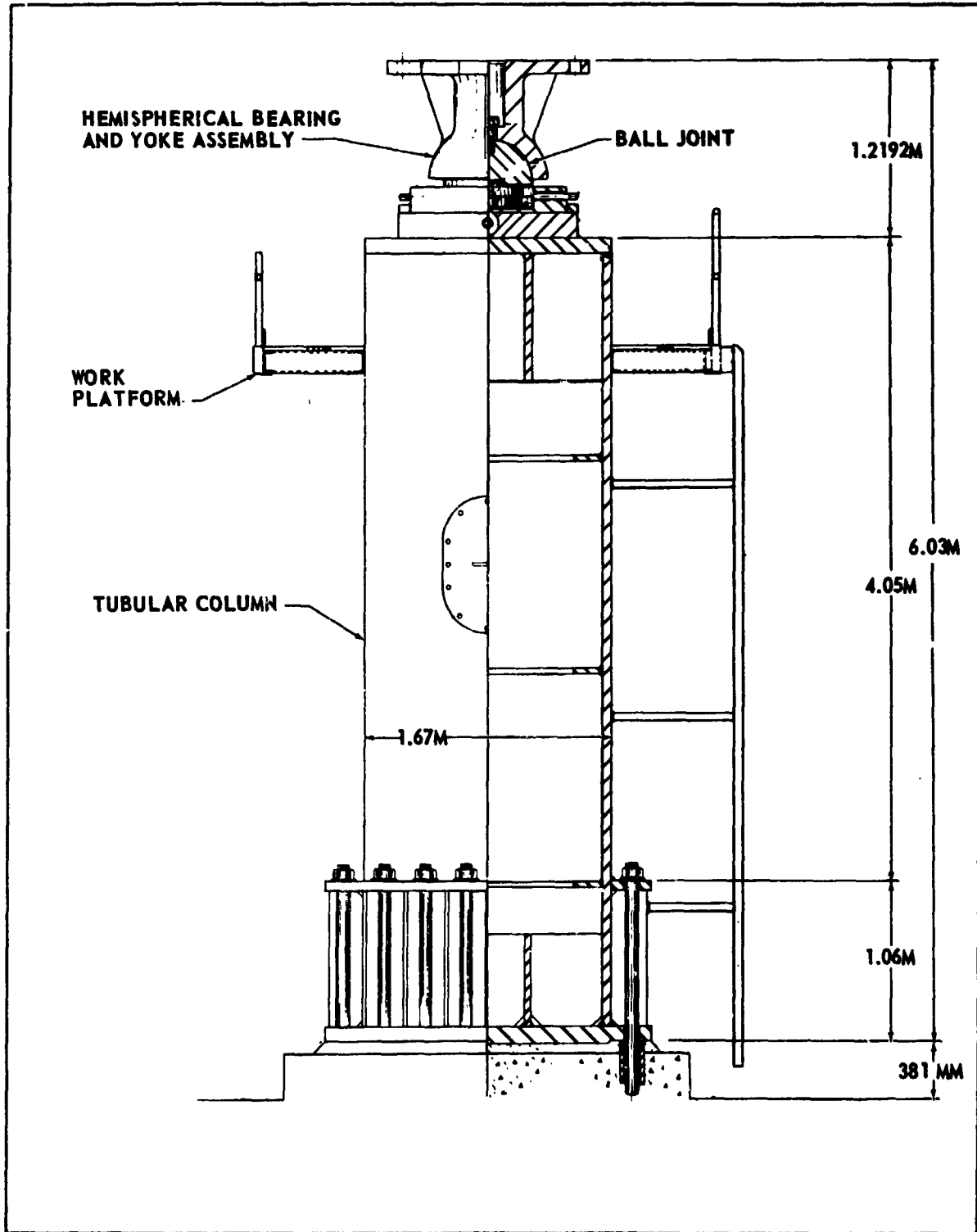

Figure 7. Mount Mechanism Type IV - Fixed Column

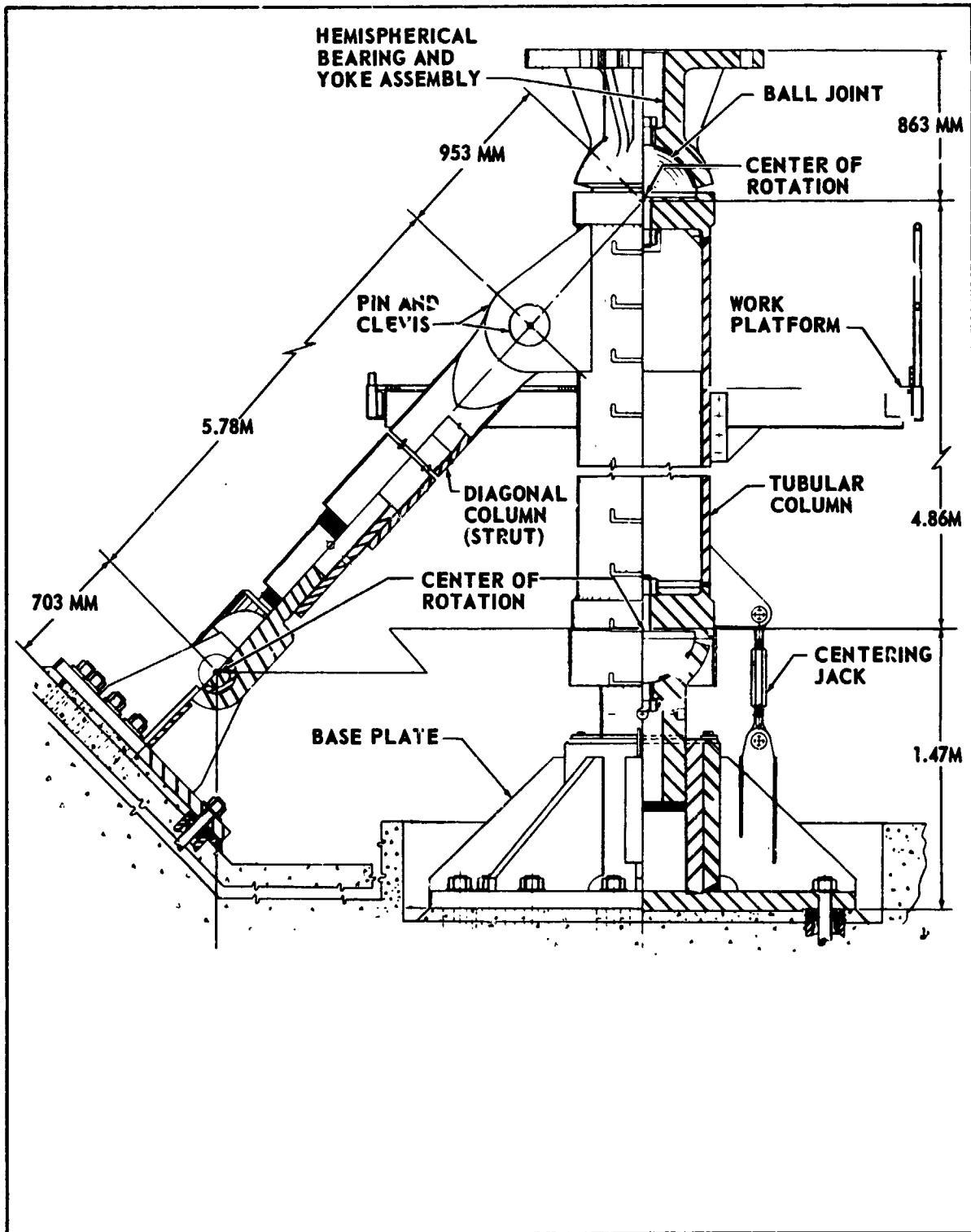

Figure 8. Mount Mechanism Type V With One Side Strut

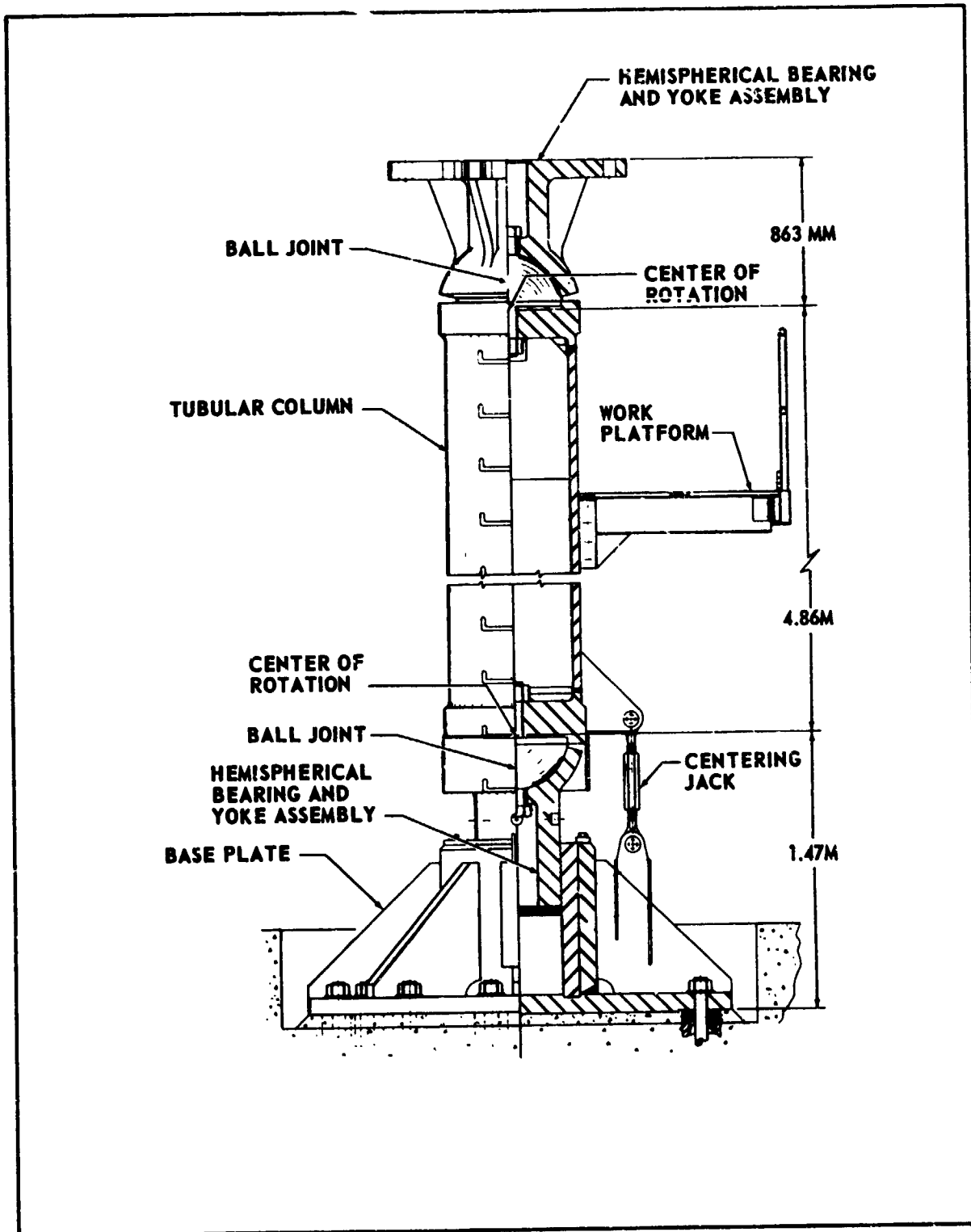

Figure 9. Mount Mechanism Type VI Without Side Strut