

PROCEEDINGS OF THE



NASA Earth Resources Survey Symposium

HOUSTON, TEXAS
JUNE 1975

N76-26631
THRU
N76-26645
Unclas
41837

FIRST COMPREHENSIVE SYMPOSIUM
ON THE PRACTICAL APPLICATION
OF EARTH RESOURCES SURVEY DATA

(NASA-TM-X-58168-Vol-2A) NASA EARTH
RESOURCES SURVEY SYMPOSIUM, VOLUME 2-A:
SPECIAL SESSION PRESENTATIONS. PLENARY
SUMMARIES (NASA) 163 p HC \$3.50 CSCL 05B

G3/43

**ORIGINAL CONTAINS
COLOR ILLUSTRATIONS**

VOLUME II-A

SPECIAL SESSION PRESENTATIONS

PLENARY - SUMMARIES



National Aeronautics and Space Administration
LYNDON B. JOHNSON SPACE CENTER

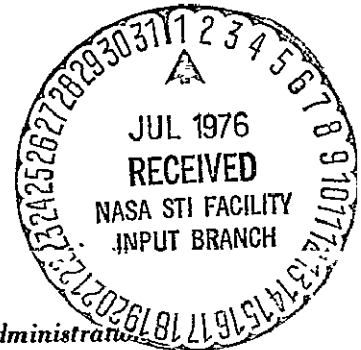

NASA  Earth Resources Survey Symposium

VOLUME II-A

SPECIAL SESSION PRESENTATIONS

Plenary
Summaries

PREFACE

The first comprehensive symposium on the practical application of Earth resources survey data was sponsored by the NASA Headquarters Office of Applications from June 9 to 12, 1975, in Houston, Texas. The Lyndon B. Johnson Space Center acted as host.

This symposium combined the utilization and results of data from NASA programs involving Landsat, the Skylab Earth resources experiment package, and aircraft, as well as from other data acquisition programs.

The primary emphasis was on the practical applications of Earth resources survey technology of interest to a large number of potential users. Also featured were scientific and technological exploration and research investigations with potential promising applications.

The opening day plenary session was devoted to papers of general interest and an overview. The following 2½ days were devoted to concurrent discipline-oriented technical sessions and to three special sessions covering State and Local Users, Coastal Zone Management, and User Services. These special sessions were structured to provide governmental and private organizations with a comprehensive picture of various applications in the management and implementation of remote-sensing data use in their own programs. The concluding day was a summary with selected state, international, and technical session papers, summaries of significant results from special and technical sessions, and an overview of Federal agency and international activities and planning.

Volumes I-A, I-B, I-C, and I-D contain the technical papers presented during the concurrent sessions. Volume II-A contains the opening day plenary session and the concluding day summary sessions. Volume II-B contains the special sessions. Volume III contains a summary of each session by the chairman and session personnel and provides an overview of the significant applications that have been developed from the use of remote-sensing data. Volume III also includes the conclusions and needs identified during the individual sessions and workshops.

Opinions and recommendations expressed in these reports are those of the session members and speakers and do not necessarily reflect the official position of NASA.

Olav Smistad
Symposium Coordinator

This document is “made available under NASA sponsorship in the interest of early and wide dissemination of Earth Resources Survey information and without liability for any use made thereof.” (NPD 8000.2A March 16, 1973)

NASA  Earth Resources Survey Symposium

PROGRAM COMMITTEE

Charles W. Mathews, NASA, Chairman
Joseph Carlson, Public Technology, Inc.
Dr. John DeNoyer, U.S. Geological Survey
Dr. M. Frank Hersman, National Science Foundation
Daniel J. Fink, AIAA, Space Applications Board (NRC)
Harold Finger, General Electric Co.
Dr. Stanley Freden, NASA
Willis Hawkins, Lockheed Aircraft Corp.
Russell R. Schweickart, NASA
Pitt Thome, NASA

SYMPOSIUM COORDINATORS

JOHNSON SPACE CENTER
Olav Smistad and Edward O. Zeitler,
Earth Resources Program Office
OFFICE OF APPLICATIONS
Dan Richard, User Affairs

ADMINISTRATIVE SUPPORT

Industrial Economics Research Division
Texas A. & M. University

SESSION LEADERS

AGRICULTURE

(Includes Agriculture, Forestry, Range Resource Inventory and Management)

Richard Baldwin, Chairman
Cargill, Inc., Minneapolis, Minn.
James Murphy
U.S. Department of Agriculture, Agricultural Stabilization and Conservation Service, Houston, Tex.
Ryborn Kirby
NASA Lyndon B. Johnson Space Center, Houston, Tex.
Kenneth Suit
NASA Lyndon B. Johnson Space Center, Houston, Tex.

ENVIRONMENT

(Environmental Surveys and Applications)

Kessler Cannon and Ronald Myles, Chairmen
Department of Environmental Quality, State of Oregon, Portland, Oreg.
Dr. Ralph Shay
Oregon State University, Corvallis, Oreg.
Dr. Lawrence Greenwood
NASA Langley Research Center, Hampton, Va.
Howard Curfman
NASA Langley Research Center, Hampton, Va.

GEOLOGY

(Includes Geological Structure, Landform Surveys, Energy and Extractive Resources)

Dr. Floyd Sabins, Chairman
Chevron Oil Field Research Co., La Habra, Calif.
Dr. Larry Rowan
U.S. Department of the Interior, U.S. Geological Survey, Reston, Va.
Dr. Nicholas Short
NASA Goddard Space Flight Center, Greenbelt, Md.
Robert Stewart
NASA Lyndon B. Johnson Space Center, Houston, Tex.

INFORMATION

(Information Systems and Services)

USER SERVICES

Dr. David Landgrebe, Chairman
Purdue University/Laboratory for Applications of Remote Sensing, West Lafayette, Ind.
Terry Phillips
Purdue University/Laboratory for Applications of Remote Sensing, West Lafayette, Ind.
Timothy White
NASA Lyndon B. Johnson Space Center, Houston, Tex.
Gerald Kenney
NASA Lyndon B. Johnson Space Center, Houston, Tex.

LAND USE

(Includes Regional Planning)

STATE/LOCAL

Charles Parrish, III, Chairman
Department of Natural Resources, State of Georgia, Atlanta, Ga.
Charles Meyers
U.S. Department of Interior, Office of Land Use and Water Planning, Washington, D.C.
Dr. Armond Joyce
NASA Lyndon B. Johnson Space Center, Earth Resources Laboratory, Bay St. Louis, Miss.
Robin Rowley
NASA Lyndon B. Johnson Space Center, Houston, Tex.

MARINE RESOURCES

(Includes Marine Resources, Ocean Surveys)

COASTAL ZONE MANAGEMENT

Senator A. R. (Babe) Schwartz, Chairman
Texas State Senator, Galveston, Tex.
John Sherman, III
National Oceanic and Atmospheric Administration, National Environmental Satellite Service – SPOC Group, Washington, D.C.
E. Lee Tilton, III
NASA Lyndon B. Johnson Space Center, Earth Resources Laboratory, Bay St. Louis, Miss.
William Stephenson
NASA Lyndon B. Johnson Space Center, Houston, Tex.

WATER RESOURCES

(Water Resources Management)

Dr. Daryl Simons, Chairman
Colorado State University, Fort Collins, Colo.
John Teerink
Bookman Edmonston, Inc., Sacramento, Calif.
Dr. Vincent Salomonson
NASA Goddard Space Flight Center, Greenbelt, Md.
Raymond Clemence
NASA Lyndon B. Johnson Space Center, Houston, Tex.

Contents

Page

VOLUME II-A

General Sessions

INTRODUCTION	1
Nelson A. Rockefeller, Frank E. Moss, Christopher C. Kraft, Jr., and Charles W. Mathews	
OVERVIEW	3
Wernher von Braun	
REMOTE SENSING AND APPLICATIONS	7
William Stoney	
ALL YOU EVER WANTED TO KNOW ABOUT REMOTE SENSING	11
D. Wayne Mooneyhan	
APPLICATIONS OF EARTH RESOURCES TECHNOLOGY TO HUMAN NEEDS	29
Caspar Weinberger	
DEPARTMENT OF THE INTERIOR PROGRAMS	33
James R. Balsley	
U.S. ARMY CORPS OF ENGINEERS PROGRAMS	37
John Jarman and K. E. McIntyre	
THE LARGE AREA CROP INVENTORY EXPERIMENT (LACIE)	43
I. THE USE OF LANDSAT DATA IN LACIE	43
R. B. MacDonald, F. G. Hall, and R. B. Erb	
II. YIELD ESTIMATES FROM METEOROLOGICAL INFORMATION	63
Paul J. Waite	
III. A SYSTEMATIC APPROACH TO THE PRACTICAL APPLICATION OF REMOTE-SENSING TECHNOLOGY	66
Jimmy D. Murphy and Raymond I. Dideriksen	
INTERNATIONAL ASPECTS OF EARTH RESOURCES SURVEY PROGRAMS	75
Arnold W. Frutkin	
FUTURE REMOTE-SENSING PROGRAMS	79
Russell L. Schweickart	

Summary Sessions	Page
AGRICULTURE	
SUMMARY Richard-Baldwin	83
AGRICULTURAL APPLICATIONS OF REMOTE SENSING: A TRUE-LIFE ADVENTURE Earle S. Schaller	88
GEOLOGY	
SUMMARY Floyd F. Sabins, Jr.	99
A SEARCH FOR SULFIDE-BEARING AREAS USING LANDSAT-1 DATA AND DIGITAL IMAGE-PROCESSING TECHNIQUES R. G. Schmidt, B. B. Clark, and R. Bernstein	112
INFORMATION/USER SERVICES	
SUMMARY David Landgrebe	123
LAND USE/STATE AND LOCAL USERS	
SUMMARY Charles M. Parrish, III	129
PRESENT AND POTENTIAL LAND USE MAPPING IN MEXICO Héctor Garduño, Ricardo García-Lagos, and Fernando García-Simo	133
A LAND USE MANAGEMENT INFORMATION SYSTEM IMPLEMENTED IN LOS ANGELES Charles K. Paul	146
WATER RESOURCES	
SUMMARY D. B. Simons	151
REMOTE-SENSING APPLICATIONS TO WATER RESOURCES MANAGEMENT IN CALIFORNIA Barry Brown	161

VOLUME II—B

Coastal Zone Management

	Page
C-1 STATUS OF COASTAL ZONE MANAGEMENT TECHNIQUES E. Lee Tilton, III	173
C-2 PANEL: INFORMATION NEEDS — PERCEIVED AND REAL — FOR STATE DECISIONMAKERS A. R. (Babe) Schwartz, Chris Spirou, William Kier, and Michele Tetley	176
C-3 APPLICATIONS OF REMOTE—SENSING TECHNOLOGY TO ENVIRONMENTAL PROBLEMS OF DELAWARE AND DELAWARE BAY D. Bartlett, V. Klemas, W. Philpot, and R. Rogers	188
C-4 CALIFORNIA NEARSHORE SURFACE CURRENTS Douglas M. Pirie, Michael J. Murphy, and J. Robert Edmisten	195
C-5 SOUTH LOUISIANA REMOTE—SENSING ENVIRONMENTAL INFORMATION SYSTEM J. Paul Gordon, Robert H. Schroeder, and Robert H. Cartmill	217
C-6 REMOTE MEASUREMENT OF SHORELINE CHANGES IN COASTAL ALABAMA C. Daniel Sapp	224
C-7 REMOTE—SENSING APPLICATIONS AS UTILIZED IN FLORIDA'S COASTAL ZONE MANAGEMENT PROGRAM David R. Worley	232
C-8 ENVIRONMENTAL ASSESSMENT OF RESOURCE DEVELOPMENT IN THE ALASKAN COASTAL ZONE BASED ON LANDSAT IMAGERY A. E. Belon, J. M. Miller, and W. J. Stringer	242
C-9 COAST GUARD/NOAA/NASA GREAT LAKES PROJECT ICEWARN T. D. Brennan and R. T. Gedney	261
C-10 OILSPILL SURVEILLANCE, DETECTION, AND EVALUATION BY REMOTE SENSING Donald R. Jones	271

State and Local Users

S-1 INTRODUCTION Charles M. Parrish, III	281
S-2 REMOTE—SENSING APPLICATIONS IN THE STATE OF MISSISSIPPI P. T. Bankston	282

	Page
S-3 INFORMATION FLOW OF LAND- AND WATER-RELATED DATA IN THE STATE OF WISCONSIN Allen H. Miller	291
S-4 REMOTE-SENSING APPLICATIONS FOR TEXAS John Wells	297
S-5 REMOTE SENSING IN ARIZONA Carl C. Winikka and Robert E. Adams	300
S-6 ALASKA'S NEEDS IN REMOTE SENSING John L. Hall	315
S-7 USER REQUIREMENTS FOR PROJECT-ORIENTED REMOTE SENSING H. C. Hitchcock, F. P. Baxter, and T. L. Cox	319
S-8 LOUISIANA COMPREHENSIVE PLANNING INFORMATION SYSTEM Patrick W. Ryan and Ed Schwertz	326
S-9 REMOTE SENSING IN MINNESOTA: EVALUATION OF PROGRAMS AND CURRENT NEEDS J. E. Sizer	340
S-10 REMOTE SENSING IN THE STATE OF OHIO	351
I. PUBLIC POLICY Paul Goesling	351
II. SYSTEM DEVELOPMENT Frank Leone	352
S-11 THE USE OF SATELLITE DATA FOR REGIONAL PLANNING A. H. Hessling and Timothy G. Mara	356
S-12 POLICY IMPLICATIONS IN DEVELOPING A LAND USE MANAGEMENT INFORMATION SYSTEM Albert J. Landini	359
User Services	
U-1 REMOTE SENSING, A SKETCH OF THE TECHNOLOGY David Landgrebe	367
U-2 DATA AVAILABILITY AND THE ROLE OF THE EARTH RESOURCES OBSERVATION SYSTEMS DATA CENTER Allen H. Watkins	372
U-3 BRINGING REMOTE-SENSING TECHNOLOGY TO THE USER COMMUNITY John C. Lindenlaub, Shirley M. Davis, and Douglas B. Morrison	379

Earth Resources Survey Symposium

Introduction

Telegram From Nelson A. Rockefeller^a

I want to emphasize my support for the objective of the symposium: the application of emerging technology to the critical needs of the society. As those of us in government — whether Federal, State, or local — grapple with the problems of intelligent management of critical national resources and formulation of sound policy, the

value of accurate and timely information cannot be overemphasized. Those of you attending this symposium, either as developers of remote-sensing technology or as appliers of this new technology to the problems of society, are to be congratulated and encouraged in your efforts.

Statement From Frank E. Moss^b

I want to extend my best wishes for success to all of you attending the NASA Earth Resources Survey Symposium. I would like to send one message to each of you exploring the technological frontier called remote sensing: I firmly believe that the resources we have sowed in the space program will yield a rich harvest of

benefits to mankind for decades to come. Education is the key to this beneficial use of the recent and forthcoming developments in remote sensing. The satellites are the tools, but you must teach the world how to use them.

Welcome From Christopher C. Kraft, Jr.^c

We at the Lyndon B. Johnson Space Center are honored to be your host for this Earth Resources Survey Symposium. I know that many of you are here to learn the approaches of a small group to the utilization of remote-sensing technology for practical applications. Others will become aware of promising exploratory investigations from which technology is being developed to uniquely, or better, support applications in the future. We at NASA hope to learn, through dialog with you, of your needs so that this development might be focused for future technology transfer.

In 1964, we started a research program with a small group of scientists, a single aircraft, and hand-me-down equipment. This week, we will hear from an emerging

group of Federal, State, local, industrial, academic, and other users who are convinced that remote-sensing applications have entered the cost-effective era. These people are utilizing data acquired from a variety of space, aircraft, and ground platforms, from sensor systems developed and proved for unique Earth resources information purposes. I believe that you are proving to others that we are turning the corner with applied technology in applications from remote sensing.

No doubt, many of you are working closely with our Earth resources program personnel in the development and transfer of remote-sensing technology. We hope to continue this transfer with future developments in the follow-on programs.

^aVice President, United States of America, Washington, D.C.

^bChairman, Senate Committee on Aeronautical and Space Sciences, Washington, D.C.

^cNASA Lyndon B. Johnson Space Center, Houston, Texas.

Purpose From Charles W. Mathews^d

This audience includes an outstanding representation from the States, Federal government, and nonaerospace industry. I think that, for the first time in a symposium, these representatives exceed the aerospace participation. Certainly the aerospace people are here, and we have the university representation that was the bulwark of the activities in remote sensing a few years ago. We have representation from many other nations, from Europe, Africa, Asia, Australia, as well as North and South America. We also have representation from various international bodies and from many types of associations. The speakers also come from varied backgrounds. The purpose of having these varied backgrounds is really to deemphasize the space capability somewhat, and talk more about how these things are used. The whole purpose behind remote-sensing activity is to use the space capability or the aircraft capability in handling real problems right here on the surface of the Earth.

The focal point for this activity has been the Landsat-1 satellite, which was launched about 3 years ago. Landsat examines all land surfaces on the Earth, approximately an acre and a half at a time, and has almost covered the whole world. When you consider that the land surfaces on the Earth are tens of billions of acres, you realize that a lot of data have been pumped out of that satellite.

Now we have another Landsat up there that is also producing valuable data. It is still somewhat of a problem to take that data and extract the information from it in the most meaningful form. But I think that, even after you have done that, you have some problems in how to use the data in decisionmaking processes; and that is where we think the emphasis in this symposium should be. However, we are not going to cover just

Landsat. Long before Landsat flew, there were remote-sensing activities; in fact, remote sensing dates quite a way back in aerial photography and related subjects. The space people got interested in it in connection with some early Mercury and Gemini photographs in the early 1960's, and they developed a comprehensive airplane program. In Houston, we used to have an annual meeting on remote sensing where a few people, whom I will now call pioneers in this area, got together and discussed possible capabilities and waited patiently for Landsat to fly.

Since flying Landsat, we have also flown Skylab, which had a unique experimental Earth-viewing capability, and we have continued with the airplane program. We regard the remote-sensing capability as a system capability, not just a space capability. We must have people flying airplanes and people walking on the ground to really get the information out of it; and we must also have ancillary information. The basic, space-acquired information is not the only information that we use. So this meeting is going to cover all aspects of remote sensing, regardless of where the data come from — Landsat, Skylab, other satellites, or airplanes.

Many of the presentations will not be made by space people, and this is proper because the space people will not be the people applying this information. We must have this transfer activity going on in such a way that people familiar with the technical capability can work on other people's terms in bringing this very beneficial capability into use. That is not unusual, but it is not necessarily an easy job. We call this applications transfer, and I think one of the main purposes of this meeting is to promote information flow and stimulate future activities that will perform this application transfer.

^dNASA Headquarters, Washington, D.C.

Overview

Wernher von Braun^a

You may not be aware that, by participating in this symposium to further the remote-sensing technology, you are involving yourselves in what some members of the public might consider a controversial activity. For it is not at all clear to the American public that the furtherance of technology is a desirable thing. Our charter is to focus on the practical applications of Earth resources survey data gathered by both satellites and aircraft, and this is certainly advanced technology.

The public tries, just as we do, to look into the future and forecast the consequences of new developments. Predicting the future is not a notably easy thing to do; but it is reasonably easy for members of the concerned public to point out potential difficulties, which are hard for engineers and scientists to evaluate objectively.

I am reminded of the first quarter of this century when there was a lot of speculation about possible future applications of Wilhelm Konrad Roentgen's remote-sensing discovery called X-rays. The speculation surrounded the fact that all substances are transparent to X-rays; there was a real concern among more than a few Victorian ladies that men could observe them through their clothes as they were walking down the street. I daresay there might have been some speculation about this among men, as well. Now history has shown that there have been some serious problems with X-rays, but this has not been one of them.

It is more popular for critics of technology to speculate on the possible negative aspects of a new technology rather than on possible beneficial side effects. I am reminded here of mankind's historic war against that bothersome insect known as the fly. Many devices have been invented from the flyswatter to flypaper to sprays to help deal with this pest, but the automobile was not one of them. Nevertheless, the automobile has proven historically to be one of the most important technical breakthroughs in the war against flies. How? By making obsolete the stables, the breeding ground of flies, that used to be on every block in every single town and city. Elimination of the stables had a dramatic impact on the fly population. I think it is safe

to say that, had any environmental impact statement or cost/benefit studies been written on the development of the automobile, none would have touched upon this environmentally positive aspect of the motoring industry. There is a wonderful word for this kind of unexpected, happy discovery: It is serendipity, and I am convinced that it is not technologically obsolete. My message is that, as we proceed to develop technology (and develop it we must in order to improve the quality of living for mankind on this Earth), let us proceed in a measured and balanced way, honestly assessing the pros and cons to the best of our ability. In this way, we will build a solid technological foundation for future generations.

As we proceed with our task of developing the applications of remote sensing, we should keep in mind that great progress has already been made in demonstrating the utility of space applications. You may be aware that 1975 marks the 15th anniversary of the launching of Tiros-1, the first weather satellite. Tiros-1 was launched from Cape Canaveral, Florida, on April 1, 1960. Since then, 30 experimental and operational weather satellites have been launched to develop new instrumentation or to use demonstrated techniques operationally for more accurate weather forecasting. Television pictures from Tiros-1 are often oblique and poorly illuminated. Nevertheless, they have shown the organization of weather systems with a clarity never seen before and have also revealed previously unknown phenomena. Considerable progress has been made since then with the synchronous meteorological satellite SMS-2.

The operational meteorological satellite system currently provides the following basic services: pictures of the entire globe, day and night, every day; continuous viewing of the western hemisphere; temperature measurements throughout the world; and wind measurements in selected parts of the Atlantic and Pacific Oceans.

We have reached the stage in the development of this program where every major hurricane or storm is being detected and tracked no matter where it occurs.

^aFairchild Industries, Inc., Germantown, Maryland.

Additionally, meteorological satellite data are being used for nonmeteorological purposes, such as measuring the extent of snow cover and snowmelt in major watersheds for water run-off prediction purposes and to measure surface temperatures to assist in locating and eradicating insect pests such as the screwworm fly. For the future, meteorological satellites will be used to measure atmospheric ozone content and natural air pollutants on a worldwide basis.

President Ford said recently, "More accurate daily weather forecasts, as well as early warning of deadly and destructive storms that once could sweep in from the sea unannounced, have had an immeasurable impact in making the lives of millions more pleasant, productive, and secure. ... We can be proud that people everywhere can benefit from this practical application of U.S. space science and technology."

Communication satellites have had an impact during the past decade at least equal to that of meteorological satellites. It is often observed that the world is growing smaller in terms of the increased and more rapid contact with people who were once remote from us. This improved contact could not occur to anywhere near the extent it has without a revolution in communications, and a major part of this revolution has been due to communications satellites. It is now possible for you to dial direct from your hotel room in Houston to Japan in a matter of minutes. The quality of the circuit should be almost as good as calling from Houston to Washington, D.C., or maybe better. The same service is available in calling Iran, Argentina, and Chile, when, in the recent past, communications to these same places might have taken hours or days, depending on atmospheric conditions and the demand for circuits. I am aware of a case when a caller from New York to Tehran a few years ago was informed that it would take 9 days to complete his call because of trouble on the circuit and the backup of people waiting. Delays of this type were not conducive to business or pleasure, but fortunately, they are rapidly becoming a thing of the past. Last year, there was a worldwide network of 94 communications satellite antennas at 74 Earth stations in 55 countries. More than 100 countries, territories, or possessions were leasing services of satellites on a full-time basis. Since these communications satellites have a multipoint communications capability, it is possible for countries in approximately one-third of the globe to communicate directly with each other. There are now about 325 communications satellite pathways among countries with Earth-station facilities. This indeed marks a revolution when compared with the number of pathways available just a decade ago.

All of these impressive developments do not mark the end of technology growth in satellite communication. Research is continuing, for example, in using the Applications Technology Satellite ATS-6 to provide educational and health services to isolated communities in Appalachia, Alaska, and India.

With this background of successful accomplishments in space applications, I would like to turn now to the object of this meeting: Earth resources surveying. A lot has happened since the last Earth resources symposium held in Washington, D.C., in December 1973. The Landsat-1 spacecraft, completing its third year of successful operation in orbit, has continued to acquire quality data beyond the lifetime predictions of its most optimistic supporters. It has now been joined in orbit by Landsat-2; together, they provide the capability of acquiring repetitive data every 9 days instead of 18 days previously. Landsat-C is scheduled for launch in late 1977, which should provide for continuity of satellite remote-sensing data well into the 1980's. Work is proceeding to define and develop the thematic mapper instrument in the Earth resources spacecraft to follow Landsat-C. The thematic mapper is a scanning device which should have six or seven channels, including three in the medium and thermal-infrared portions of the spectrum, and a resolution on the order of 30 to 60 meters. Also on the way is a heat capacity mapping mission (HCMM), the first of the small, low-cost applications Explorer missions, which is scheduled for launch in 1978. It will carry a thermal-infrared sensor and will be in a special orbit that will allow for the acquisition of maximum and minimum day and night surface temperatures for thermal inertia measurements. Considerable effort is also being made on the development of microwave sensing instrumentation. The Space Shuttle Program should be of considerable assistance to this effort in the early 1980's.

On the data processing side, improvements are well underway to provide the capability, by 1977, for getting satellite remote-sensing data to users within 48 hours of acquisition instead of the 6 to 8 weeks it takes now. This improvement is necessary for the data to be used operationally in many applications areas.

The accomplishments in this program have been significant enough that on May 2 of this year, Dr. Joe Clark of NASA and Dan Fink of the General Electric Space Division, representing the government/industry team which developed Landsat, were awarded the Collier Trophy by the National Aeronautics Association. The Collier Trophy award, established in 1912 by Robert J. Collier, is given annually "for the greatest achievement

aeronautics or astronautics in America, with respect to improving the performance, efficiency, or safety of air or space vehicles, the value of which has been thoroughly demonstrated during the preceding year." The selection committee was unanimous in choosing Landsat as the outstanding aerospace program of 1974. It is the first time that an unmanned aerospace development program has been so honored. This is an auspicious sendoff for a symposium designed to maximize the use of data from the Landsat program.

Looking to the future, I am convinced that, when people in the 22nd century and beyond look back on

the 20th century, much as we do now to ancient Rome and Greece, this century will stand out clearly as the time when man first left the planet and travelled in space. Memory of almost everything else that we experience will be eclipsed by the passage of time. I am also convinced that future generations will consider this giant step forward in man's ability to physically traverse the heavens, a giant step forward as well in bringing benefits to man that hitherto were beyond his reach. We have a good start, and the future is full of promise. We are here to use our best efforts to see that this promise is fulfilled. Let us work hard.

Remote Sensing and Applications

William Stoney^a

We in NASA have a very strong feeling that the space efforts in which we have been engaged for these many years have the capability to do a great deal for the needs of people here on Earth. The many applications have been ably illustrated by Dr. von Braun.

I would like to give you some opinions that we have developed working with people like you over the past 8 years as to the needs that we are attempting to serve. I am going to try to put them together in a way that will reflect the way we look at them, and thus the way we think of our technology and of our future decisions to make the technology better. I want to do this for two reasons: first, because we do have a very diverse audience and this may help to put everybody on about the same scale or reference system; second, because, in essence, the purpose of this conference is to help us learn more about what the user really needs, what he is doing with the data, and the characteristics he would like to see changed and made better. This will allow you to determine whether we have been communicating, and I would really welcome comments on this.

I will present a series of tentative conclusions that we have reached regarding the applicability of our data and the techniques we have been using. I am going to talk mainly about the Landsat that has been operating for the last 3 years because so many people have been working with those data, and Landsat is a strong focal point of this conference. But, in these conclusions, I am also taking into account the work we have done in our aircraft program and the work that has been coming out of the Skylab experiment.

The first conclusion is from our own observations. We believe that the multispectral scanner (MSS), the instrument that is on Landsat and has been providing the data, has proven to be the best way of looking at the Earth from space to date. This is not just a trivial statement because this discovery was not totally expected when the first Landsat was launched. The multispectral scanner was not the prime instrument on that spacecraft. There are three cameras – the return beam vidicons – that were considered primary for the

flight. The MSS was considered the backup because there was some concern over its capability to register the geometry of the scenes below it precisely enough for people who want to locate and map things. I think the experiment has shown that these fears were not well founded, that this type of instrument with its moving mirror, operating on a spacecraft which is moving a little bit also, will still give motions small enough that the data can be used at scales of 1:500 000 and 1:250 000 without any extensive corrections. Using the most sophisticated techniques we can put on something like this, we have even seen people usefully register the data from several scenes on topographic maps at scales as great as 1:24 000, and that is pretty impressive for something that was considered a very wobbly operation. So, I think that the scanner technique has received its initial approval and positive test. I might comment also that there was some concern about that mirror moving so many times, and how long it would last. As you know, we are almost in the third year, and it is still working.

We can now discuss the second conclusion that I think has been important in our experiment, namely that the use of color analysis alone as a means of identifying the substances down here on Earth has proven to be a very practical and very exciting dimension in photointerpretation. In a sense, it has freed the photointerpreter from his dependence on the eyeball and on shape, size, shadow, and context that he traditionally uses to interpret images. This aspect is particularly important because it has opened up a whole new dimension in types of users who probably could not think of using remote sensing if they were restricted to older techniques. This is because remote sensing allows the classification of large areas of land to be done on a computer and, therefore, is relatively economical; and it can be done over and over again so the changes can be recorded. We can start to think of uses that involve repetitive coverage of large areas, and that has really been a well-proven aspect of the program today. But it is that type of thing in particular on which more

^aNASA Headquarters, Washington, D.C.

information is needed; we need more detail about how people are using the data in this dynamic way.

The third aspect of our experiment is connected to the question of resolution. The initial comment about Landsat when it was being planned was that not many people could use it because 80-meter resolution simply was not enough to define the kinds of things in which people were interested. However, as more users have been working with the data, we have found out that more and more people are quite happy with 80-meter resolution and are finding all sorts of ways to use it. Again, this is a conclusion that we would like to see investigated. It is not that we are stuck particularly on 80-meter resolution. As Dr. von Braun mentioned, we think the technology is capable, and we are actively looking at an instrument that would give approximately 40 meters. But, still, anytime we move in that direction, we want everybody to be very conscious that you do not multiply the amount of data by 2 if you go from 80 to 40 meters; you multiply it by 4. And it gets to be a pretty big mass of data that has to be handled. In fact, the rate of data we would send back from the 40-meter resolution, compared to the 80-meter we have now, would go from 15 megabits to 100 megabits. While we think that it is technically feasible, it depends upon the users, their need is going to determine whether it is valuable enough to do and valuable enough to design the ground systems that are going to handle it.

The next conclusion we can draw from the impressions we have obtained over the past couple of years is the need for repetitive data, as well as the need to get the data out as soon as we have taken it. We admit that we were rather unprepared for this in our planning. We certainly did not plan a ground system that would allow this to happen. We regarded getting the data to the user as something that could wait for 3 or 4 weeks because we were dealing with something relatively static. The feedback is no. That is not true for a lot of reasons. One reason is that the ground truth is perishable. This comment even comes from the experimental community which does not have a real urgency to make a decision on something. But, from those users who have decisions to make (and we are seeing more and more of these people), the need to have the data on time has been brought forward very strongly. As a result, we are planning to make systems that will operate in a time frame of about 24 to 48 hours. But this is going to take time, and we probably will not be able to do that for all the data for a couple of years.

The need for rapid data delivery indicates that the trend is away from use of the data just for simple mapping, and toward its use in managing dynamic

situations. Many users stress the need for frequent, current data. For instance, agricultural people are talking about wanting production figures monthly, or even semimonthly. There are users, for example, those involved in watershed management, who would like to see data as often as every few days during the active parts of their seasons. So we have to face up to this need for data on a closer repetitive time scale. That is very important for us because it affects our systems of the future in two very significant ways: It affects the number of satellites we are going to have to fly to get the data. We are now flying two Landsats, and I think we will get some experience with the 9-day interval that they give us. In the next couple of years, that will be very valuable experience. The need for rapid data distribution also affects the ground systems as we add to the amount of data we are accumulating. We have to classify these data, put them into storage, and get them out to the users. The size and character of our future systems will depend critically upon the needs of the user community for repetitive coverage and rapid data analyses.

We are getting another message from our users, and it comes as a surprise: The ability of the user community and the purely experimental community to use digital data techniques is developing faster than we had anticipated. I am on less firm ground on this conclusion than on almost any other that I have mentioned so far, because there are a lot of users and I have not taken a precise survey. But, certainly, as you will see at this conference, there are many more papers concerning digital work than there were in the last conference. I think there are more of you who understand the data and have the ability to really work with them. This is really a vital step because only with the digital data is the full power of the information they contain brought to bear. So, that is an important situation in our experiment, and we would like to hear more about that.

Those are some of the basic opinions that have reached us in our conversations with users during the last couple of years. As a result, we think that we can make some speculations about the future. If we did that right now, we would say that we are looking at a need for a multispectral scanner with increased performance, taking advantage of the fact that scanning techniques have proven successful. Aircraft and Skylab experiments have indicated the need for a few more channels to get more discrimination of the radiation we see from the Earth. We need a little more precision in geometry; maybe 40 meters is a good number to think about. There is a definite need to get data at some frequency greater than 18 days, and to get the data to the user within 24 hours.

The need to give the user digital data so that he gets first-generation data in a usable form is certainly becoming a key feature in our planning.

Several other trends are observable. As more of you get involved with looking at the remote-sensing data, we are running into more specialized situations where, perhaps, a different type of instrument would really serve the need. A couple of examples are already upon us. We are developing the coastal zone color scanner, which is simply a multispectral scanner designed to particularize the reflections we get from the surface of the water and use just the right channels to maximize that information we get. Then, it will be possible to analyze the waters along the coast for sedimentation, chlorophyll, and other surface characteristics more precisely. Another instrument called the heat capacity mapper, which is also a scanner, emphasizes thermal data but takes the thermal data at the time of maximum and minimum heating, and maximum and minimum temperature, and explores the information that you get from the analyses of temperature differences. This leads

to measurements of soil moisture and to identification of some surface features such as rocks by their physical reaction to heat, rather than by color and tone alone. There will be more things of this type, and we need to look at them more.

One final comment: The more we deal with the user community, the more we see the need for looking at the user's total job. What are the informational needs, and how does the remote-sensing information fit into that need package? Also, we are finding that more and more users can look at the data in that sense, and they are able to work with us and show us what the total requirements are so that we can take a more complete viewpoint of their requirements.

I hope I have outlined relatively clearly where we stand now. I am looking forward to hearing your papers and to changing these views, if need be. I am also looking forward to discussing these needs and requirements with as many of you as possible so we can define our techniques for the future.

All You Ever Wanted to Know About Remote Sensing

D. Wayne Mooneyhan^a

If you are a beginner in remote sensing, you are in the right place because I am also a beginner in remote sensing. I have learned that the first thing you need to do to be comfortable in the remote-sensing community is learn a group of keywords used by that community. That is true in everything, but remote sensing seems to have a particularly large set of keywords that generally are not used in other fields. I had been in remote sensing about 3 weeks, and I didn't understand anything people were saying, when I attended a symposium like this. I spent 4 days listening to all sorts of terminology I didn't understand. I soon learned that everybody was using the same group of keywords. So I learned a few keywords, and soon I was comfortable in remote-sensing discussions.

The first thing I would like to address is the subject of this presentation. It really is not, as the title suggests, everything you wanted to know about remote sensing, but perhaps, a few things that you might need to know about remote sensing. Remote sensing is really not a foreign subject. Your eyes, for instance, are remote sensors, and each of you uses remote sensing for about 95 percent of the decisionmaking you do. Your eye, however, is limited to the visible region in real time, with no replay. So the only thing you have to get used to is sensing other regions of the spectrum and the methods of recording and handling the data. Remote sensing is not new; in fact, it is very old. Man has forever assessed his resources remotely. The process goes all the way back to the Garden of Eden (fig. 1). In the remote-sensing program, we hope to improve upon the methods of recording and processing the data to produce increasingly more useful information. The approach that the Earth Resources Observation Program uses is to provide a product that a resource manager might use in making a better, more rapid, or less expensive decision. Final products from remote-sensing sources generally take the form of reports, maps, or statistical data, just

like information from other sources; the only difference is the method used to obtain and process the data.

As shown in figure 2, the approach is to use a group of remote sensors to record the data, either on film or on magnetic tape. It is then processed into a format that the resource manager can use as information to aid him in making decisions.

Now you have to get used to remote-sensing thinking just a little bit, and figures 3 through 8, I hope, will give you some appreciation for thinking remote sensing. Figure 3 is a photograph of a one-story masonry building with a flat roof, and if you stand at this particular vantage point, that is all you can tell about it. You can learn a lot more about that building by going either one of two ways. You can go inside the building (fig. 4), where it becomes obvious even to the most casual observer that the building houses a library. If you have a job of planning, transportation, zoning, or land management involving this building, you are probably less interested in whether or not it is a library than you are in where it is and how it fits into the community. If you move up to about 6000 feet, you can learn quite a bit more about the building, as shown in figure 5. You can still tell it has a flat roof because you can see roofs in the area that are not flat, and I am told that some of the learned interpreters can tell that it has only one story, although I cannot. Now, from this data source, you know that the building is located in an institutional complex in what appears to be an urban area. You can also tell something about how many cars can be parked around it and the transportation to and from the building. If you move to still a higher vantage point, up to about 20 000 feet, as shown in figure 6, you can tell even more about the building. You can still tell that it is a flat building, you can tell how large it is, you can still tell that it is in the middle of an institutional complex in what now appears to be a residential area in what still appears to be an urban area. But you know a lot more

^aNASA Earth Resources Laboratory, Bay St. Louis, Mississippi.

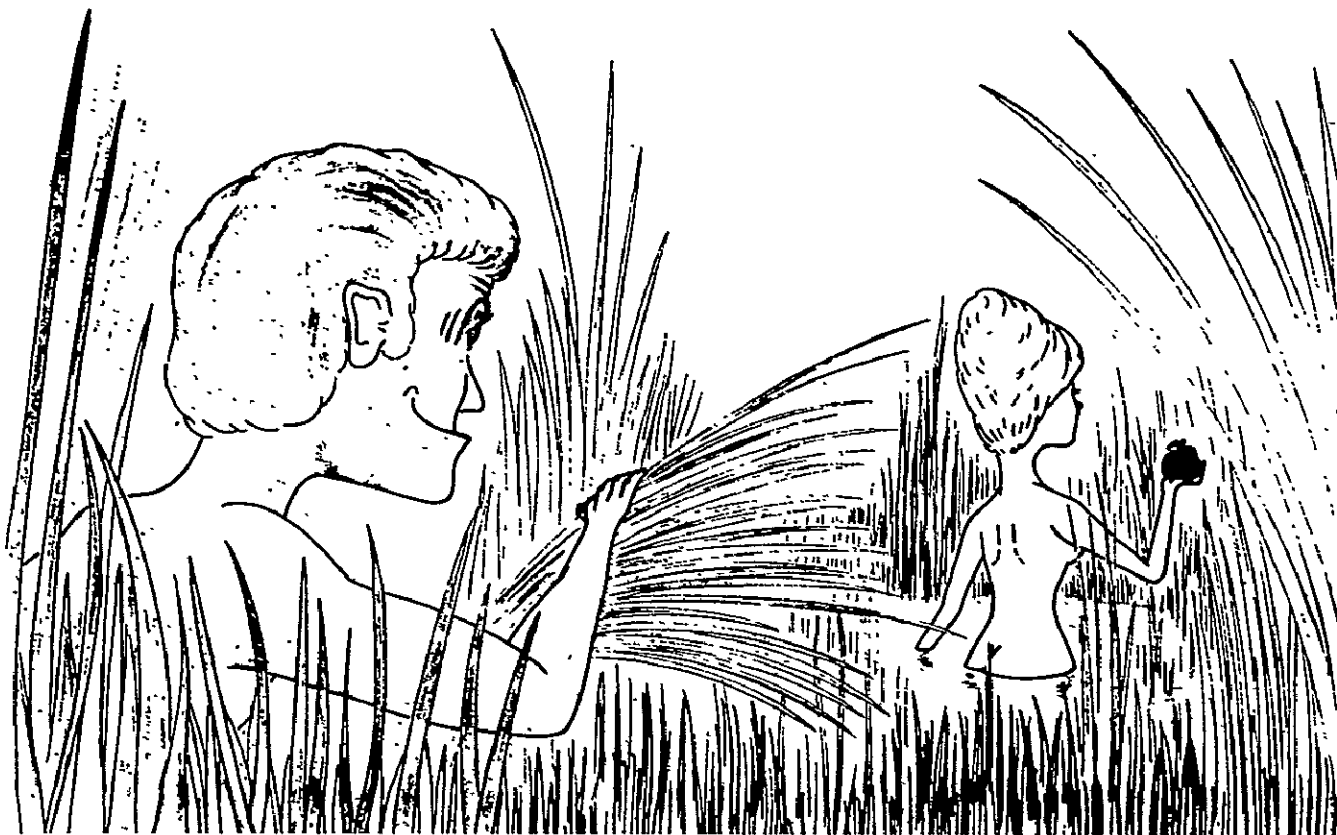

Figure 1.— Remote sensing: as old as Adam and Eve.

about the building now. You know the transportation problems of getting to it; you know the proximity of the people that use it; and you can, therefore, do a lot more in the art of planning. If you continue moving up, what you would see at 60 000 feet is shown in figure 7. You would find that you are not really in an urban area at all, but in a small town in a generally rural area with forest and agriculture. On the original photograph, from 60 000 feet, you can still find that institutional complex, and, within it, that flat, one-story building. You can tell a little bit about the transportation corridors in that it has railroads and interstate highways. You can even tell that it is located along an area of bottomland hardwoods which, in the part of the country that the image was taken, represents a creek or river bed. Moving finally to Landsat altitude (fig. 8), the town is shown located along the little creekbed on a major water thoroughfare. From this altitude, you can tell much more about it, in that it is in the coastal plains region. If you pursue that a little farther, you have a lot more information about the area. The point is that at each increasing altitude, you learn more about the subject, but you give up some detail. In figure 8, you cannot find

the flat, one-story building. On the original data, you can locate the small institutional area inside the residential area in that small town, and you get more detail. You cannot abandon any one of those levels if your objective is to do detailed planning. Conversely, if you are concerned with general transportation in the coastal region, figure 8 gives much better information to work with than do the ground-level or low-altitude data.

Now I want to talk a little bit about words that you will probably be hearing in the next few days, and some of them are fairly basic. To begin with, you will hear a lot of discussion about "resolution." Is Landsat resolution good enough? Do you need more? What price do you pay for it? Resolution is a term that describes how well a system can isolate an object in a scene, and you can calculate it in a very straightforward way. You simply multiply the scale by the limiting resolution to determine the smallest theoretical object that you should be able to find on an image. For instance, if you have a 1:50 000 scale and your limiting resolution is 50 line-pairs per millimeter, you simply multiply 50 000 by 50 millimeters, which calculates to a theoretical minimum size of 1 meter. With such a system, you

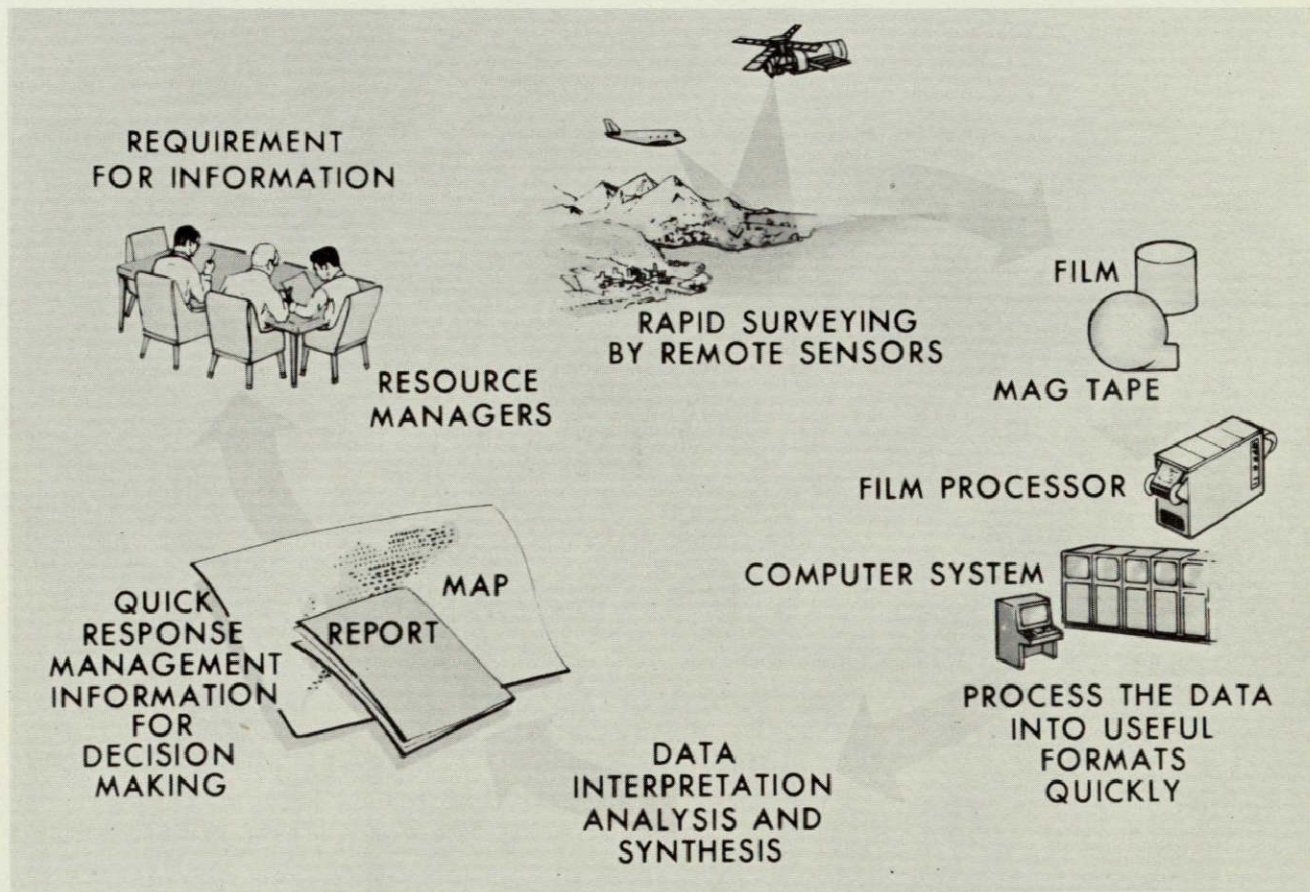

Figure 2.— Earth observations by remote sensing.



Figure 3.— One-story masonry building. Point of reference: front.



Figure 4.— Point of reference for building shown in figure 3: interior.

should theoretically be able to discern an object that is 1 meter in size.

Figure 9 explains the term “spatial resolution.” In a film/camera situation, resolution and spatial resolution are identical. Therefore, spatial resolution describes the smallest object that can be discriminated or observed on an image. In a lot of the images that you will be seeing,

the camera used was the RC-8 with a 6-inch lens. From 60 000 feet, you should be able to resolve a 12-foot object on the imagery.



Figure 5.— Point of reference for building shown in figure 3: 6000 feet above. Building (3) is clearly visible near center of photograph. This photograph is oriented with north to the lower right.

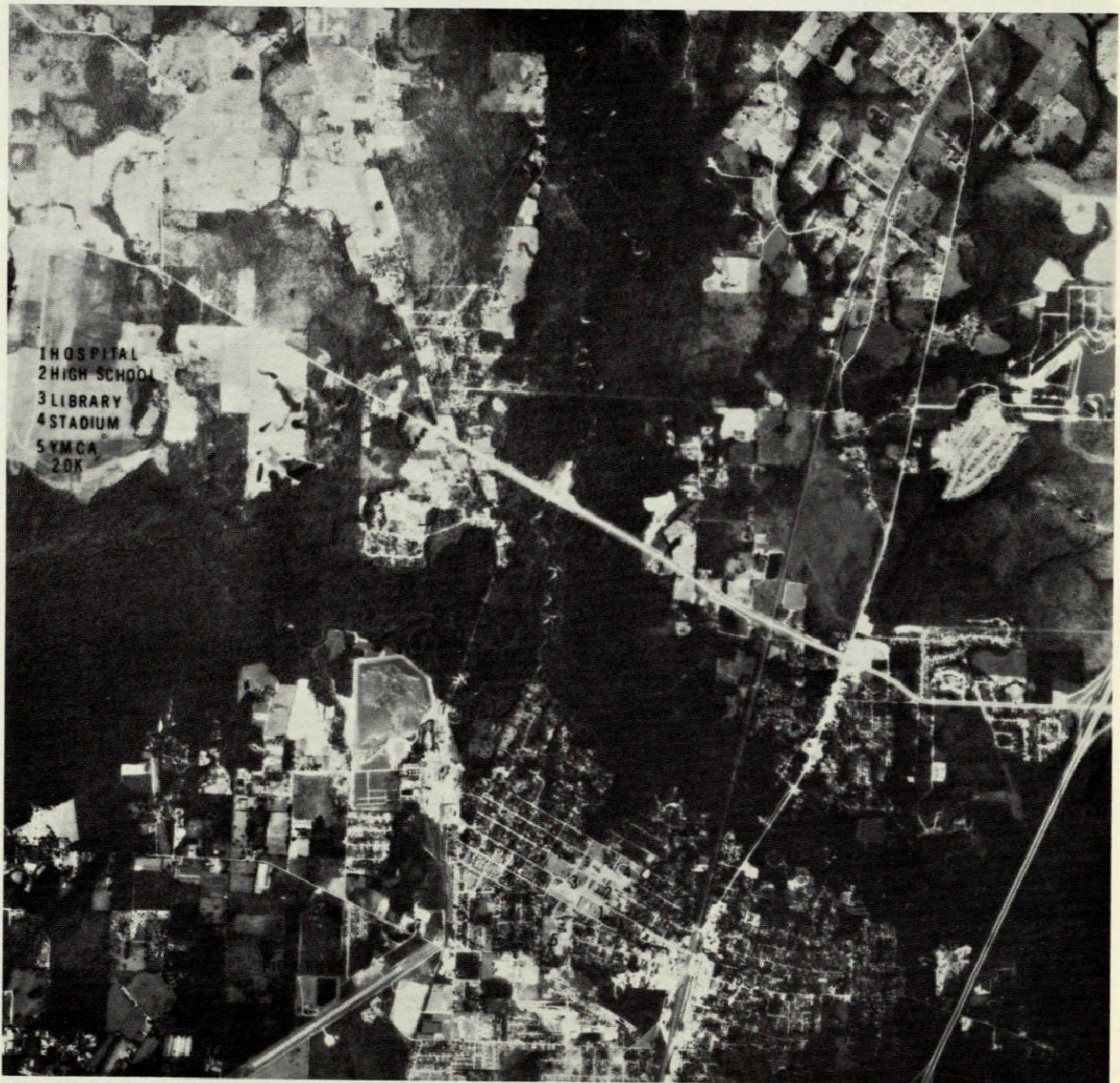

Figure 6.— Point of reference for building shown in figure 3: 20 000 feet above. Building (3) is faintly visible near the bottom center of the photograph. North is at the top.

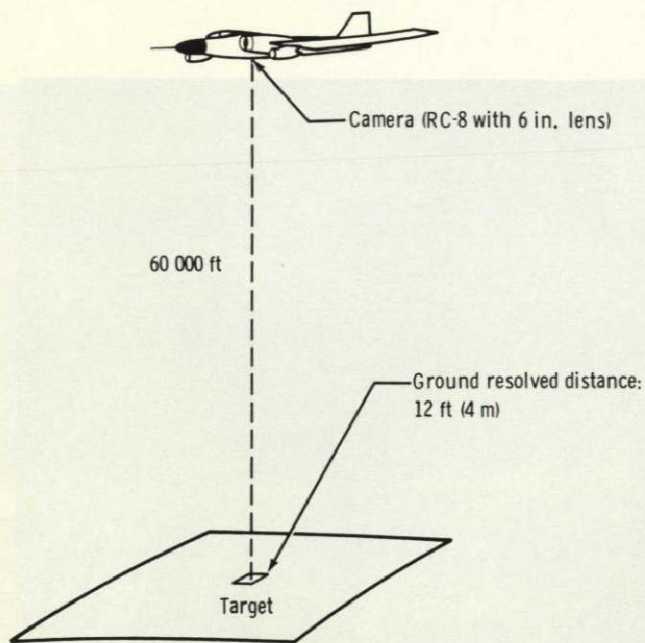
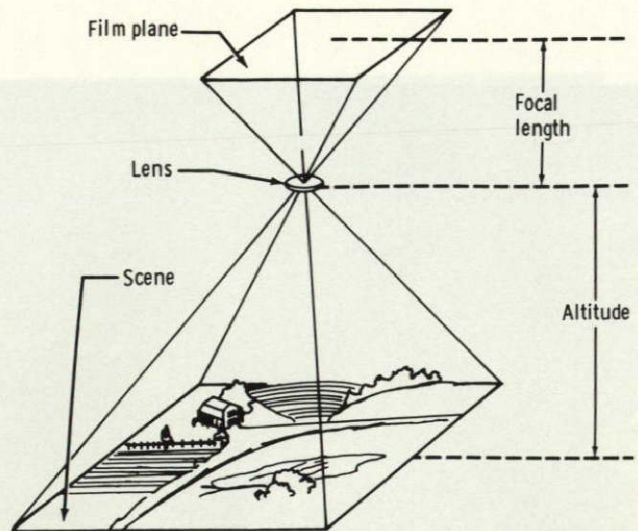

Figure 9.— Spatial resolution. The “resolution limit” or “limiting resolution” is the smallest dimension that can be observed of a target or object.

In addition to the RC-8, there are several kinds of framing cameras, including the snapshot camera you use at home (fig. 10). The focal length is the distance between the lens of the camera and the film plane. If you want to determine the scale of the imagery, you simply divide the focal length of the camera into the distance from the subject. The framing cameras that we use in most of our platforms have 6-inch focal length; so if you fly it at 60 000 feet with a 6-inch focal length, you get a scale of 1:120 000. The RC-8 is the camera used in the example on spatial resolution, and the resolution at that scale is 12 feet.

Another type of camera is the multiband, and there are two basic configurations, as shown in figure 11. In the early days, four separate cameras, with different type film or different filters, were grouped together to trigger simultaneously to produce a multiband image. Today, a single 9-inch camera with four lenses and different filters is used. With this camera, film is exposed through the different band-pass filters, and each frame responds to a selected portion of the spectrum. However, when this is done, some resolution is generally sacrificed. A disadvantage of most multiband cameras is that the resolution is not as good as that of most framing cameras with the same film base. The advantage of the multiband cameras is that a wider range of energy in more selective parts of the spectrum can be recorded.



Typical Characteristics

Focal lengths: 3.5 in. (88 mm)
 6 in. (150 mm)
 12 in. (300 mm)
 Format: 9 by 9 in. (23 by 23 cm)
 Resolution: 40 lines/mm
 Ground resolved distance: 12 ft (4 m) at 60 000-ft alt

Figure 10.— A framing camera exposes the total scene instantly.

A third type of camera, the panoramic, is shown in figure 12. The panoramic camera records on a curved strip of film and scans and exposes a swath as the aircraft flies along the flight line. The basic advantage of the panoramic camera is improved resolution with large area coverage. Most panoramic cameras have resolutions greater than those of the framing cameras.

One of the terms I am sure you will hear during the next few days is “multispectral scanner” (MSS). The basic sensor on the Landsat is a multispectral scanner. Figures 13 and 14 present the basic schematic of the multispectral scanner. It is called a scanner because it has a scanning mirror to focus the energy from the scene onto the detectors for recording purposes. From any instantaneous field of view, the scanner records the energy input by reflecting it from the mirror through a prism arrangement which breaks the energy down into discrete wavelengths and causes it to fall through filtering arrangements onto detectors. The results are then amplified, transmitted, and/or recorded on magnetic tape. From the tape, the data can be either film recorded or displayed on a cathode-ray tube (CRT) and manipulated by computers. The scanners in the program range in size from 4 channels on the Landsat

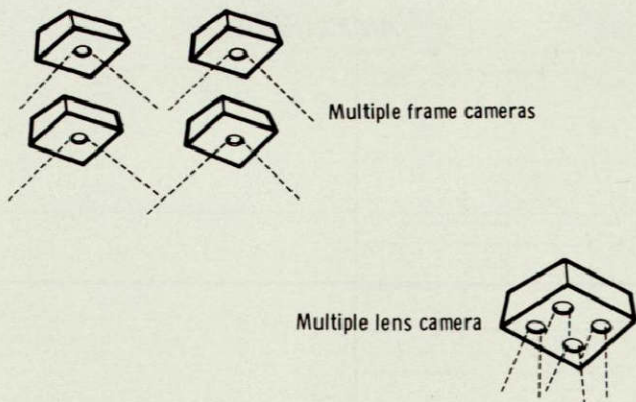

Multiband photography

- Cameras (or lenses) are synchronized to simultaneously expose the same scene.
- Cameras are loaded with different film types, e.g., combinations of black-and-white, color, color infrared, black-and-white infrared, et cetera.
- Black-and-white films are exposed through different band-pass filters, with each frame responding to a selected portion of the spectrum.

Typical Characteristics

Focal length: 2 to 6 in. (40 to 150 mm)
 Formats: 70 mm film; 9 by 9 in.; 4(3, 5 by 3, 5 in.)/9, 5 in.
 Resolution: 25 lines/mm

Figure 11.— Two types of multiband cameras.

satellite to 24 channels on the C-130 aircraft. The data from the four-channel multispectral scanner on Landsat look something like figure 15. When the data are received, for instance, each one of these numbers is the energy level recorded as a voltage output versus energy input for an instantaneous field of view or a resolution element. On a scale from 1 to 256, the energy level in the green band was 26; the red band, 18; one near-infrared band, 43; and the other near-infrared band, 24. Those numbers describe that particular resolution element. Figure 15 is digitized data of the upper left-hand corner of a Landsat frame, and if you filled it out, you would have the data for the entire frame. These numbers then can be handled in a computer to either reconstruct an image or to be manipulated as statistical data.

“Spectral signature” is a frequently used term that represents plotting of the energy input as a voltage output, against the wavelength for the detectors. For

instance, in figure 16, the energy level reflected and emitted from the field of green vegetation is received by the sensor and, through the prism arrangement, the mechanism causes the energy levels to be recorded by each of the detectors in the sensor. Those energy levels then, plotted against the wavelength, become the spectral signature and you can construct a spectral signature for any instantaneous field of view of the scanner.

A ground “resolution element” of a scanner represents the area covered by the instantaneous field of view of the scanner, and you can calculate it. If you know the type of scanner you have, you can quickly determine the instantaneous field of view. For instance,

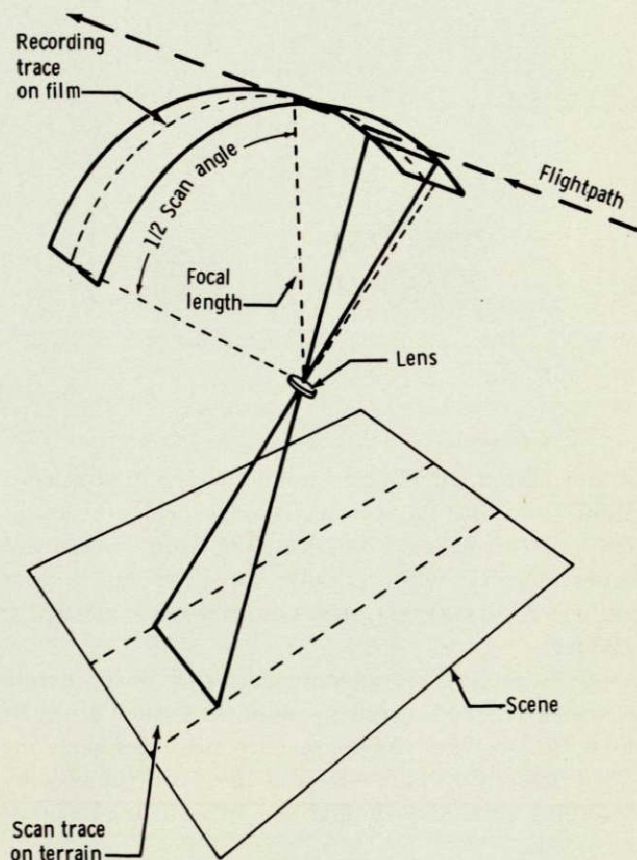

Typical characteristics

Focal lengths: 12 in. (300 mm)
 24 in. (600 mm)
 Scan angle: 120°
 Formats: 4, 5 by 25 in. (115 by 625 mm)
 4, 5 by 50 in. (115 by 1250 mm)
 Resolution: 80 lines/mm

Figure 12.— A panoramic camera exposes the scene as a swath, “painting” it on the film as the camera platform moves along the flightpath.

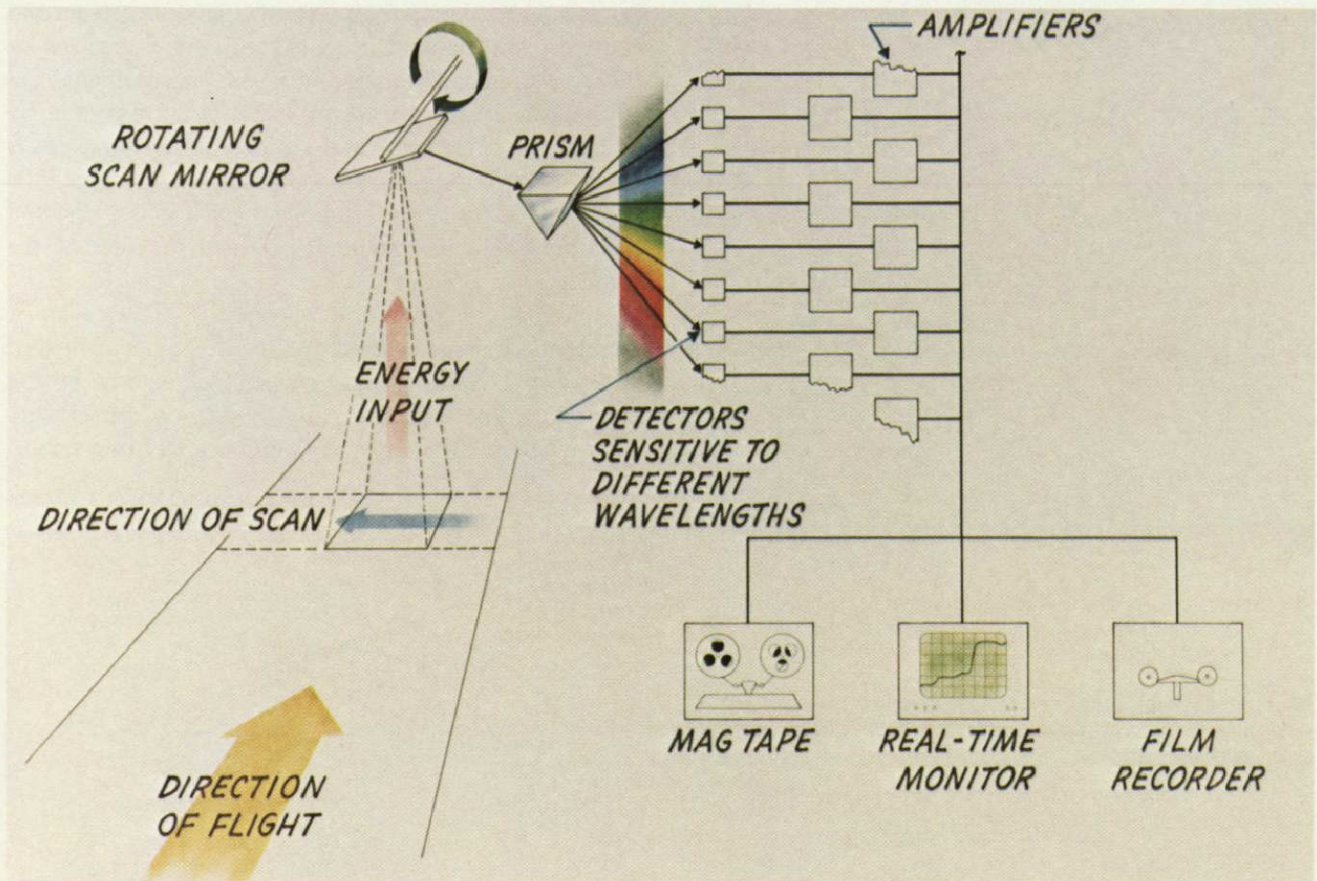

Figure 13.— Multispectral scanner.

if you have a 2-milliradian scanner and your altitude is 1000 feet, then your instantaneous field of view or resolution element is 2 by 2 feet. The resolution element varies directly with altitude; for example, if your altitude is 50 000 feet, then your resolution element is 100 feet.

A "scan line" is a contiguous row of resolution elements acquired by one sweep of the scanner across its total field of view. As the scanner progresses along the flight line, it records the scan lines contiguously by recording scanner such that the total field of view is recorded.

"Training sets" are areas within the field of view of the scanner that are either used for constructing spectral signatures or for verifying that the classification on the basis of spectral signatures is correct. A considerable number of resolution elements are required to produce a spectral signature that is statistically dependable.

There are other terms that might be helpful in understanding remote sensors. The "dynamic range" of a sensor is the range over which the sensor can record a meaningful input of energy. For instance, for a film, the

range represented by the straight-line portion of the natural logarithm (\log_e) curve is the dynamic range. It is also true with the electronic sensor that, in order to record a meaningful input, the calibration curve must be linear over the range to be recorded. There is another dynamic range that you might hear of, and that is "scene dynamic range." The dynamic range of a scene is the minimum through the maximum energy level found in that particular scene. If the scene dynamic range falls within the dynamic range of the sensor, you have recorded that scene meaningfully throughout.

No matter what kind of remote sensor you use, you have to work diligently on a thing called "ground truth," and it is usually a difficult part of the program (fig. 17). You must have a lot of it when developing a technique, and you try to get rid of it in the process of bringing that technique into an operational phase. Ground truth is usually fairly expensive; it requires people. So, if you're going to have a successful operational remote-sensing program that covers a large area, you have to minimize expense of ground truth through the process of development and gain confidence in the

remote-sensing technique. Ground truth is the only way you have of verifying that your remote sensing is, indeed, telling you what you think it is.

There are basically two types of sensors in the program: passive and active (fig. 18). The more familiar type, passive sensors, record the total reflected and emitted energies in the bands in which they work. These are the cameras, scanners, and radiometers that you hear the most about. Active sensors transmit signals and receive the reflected part of their own signal. These are primarily the active radars and the laser instruments in the system. Figure 19 shows the portion of the electromagnetic spectrum where virtually all sensors that you will hear about during this symposium operate. The portion of the electromagnetic spectrum where we use ordinary film is from about 0.4 to 0.7 micrometer; that is the range of color Ektachrome film you buy down at the corner drugstore. If you drop off the leading edge of the blue and pick up about the next 0.1 micrometer above the red, you have what we call color-infrared film. This film is highly sensitive in the reflective vegetative region and was developed during the Second World War for the purpose of detecting camouflage. From about 8 to 15 micrometers is the thermal region. The thermal scanners and other thermal sensors work in that particular region. The active and passive microwave devices operate in the 1-millimeter range and above. There is hardly any portion of the spectrum in which the Earth Observation Program does not have sensors operating. However, figure 20, which presents the atmospheric transmission characteristics, shows there are some difficulties with sensing in portions of the spectrum. You can see that the atmosphere is fairly transparent in the visible region, and that is probably why a lot of sensors work in that region. The atmosphere also has some holes in the reflected infrared and in the thermal infrared. Then it is a fairly absorbent atmosphere until you reach the microwave, where it is once again transparent. So, if you want to study something remotely, you must consider where in the spectrum you can detect the phenomena that you want to learn about, and then compare it with the transmission characteristics of the atmosphere in that particular region of the spectrum.

Figure 21 is a presentation of some of the program sensors up through the 15-micrometer region of the spectrum. A lot of our sensors operate in the visible region of the spectrum. Some, such as the 24-channel scanner in the C-130 aircraft, include the reflected infrared and thermal portions as well. This sensor concentrates a large number of its detectors in the visible

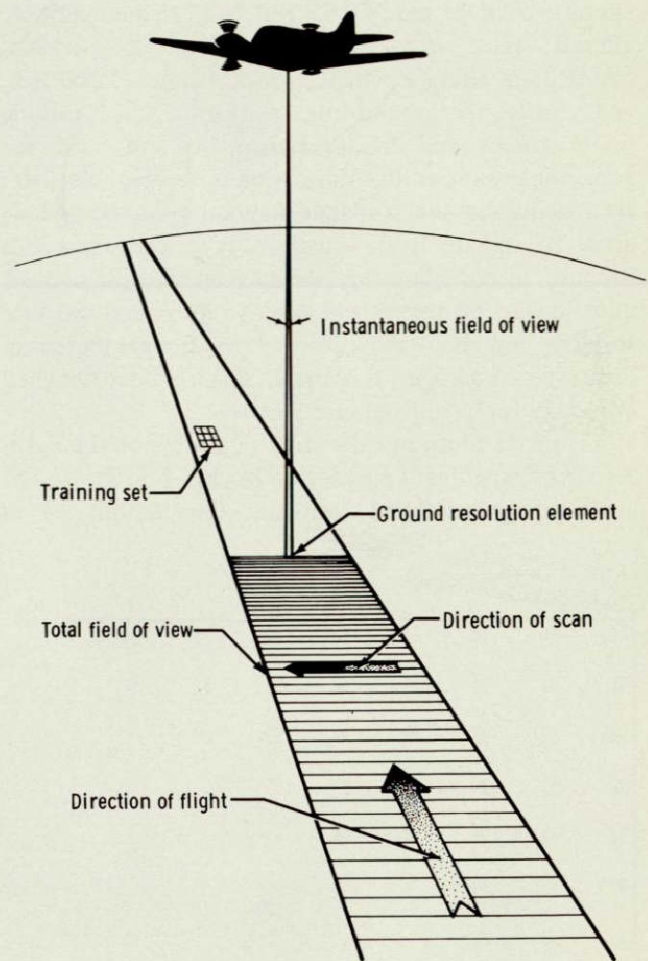

Figure 14.— Scanner geometry.

and near-infrared region, avoids some gaps where the atmosphere is nontransparent, and picks up in the thermal-infrared region. There are a couple of channels in the region where the atmosphere absorption is very high, but they were put in by the investigators for the purpose of looking at the atmosphere. The Landsat scanner operates two channels in the visible and two channels in the near and reflected infrared. Skylab avoided the region where the atmosphere is nontransparent. So, you will be hearing presentations based on data from these sensors in both high-altitude aircraft and Skylab systems.

Figure 22 presents the sensor platforms generally used in the program. These platforms include the experimental satellites Skylab and Landsat; high-altitude

aircraft, such as the WB-57 and U-2; medium-altitude aircraft, most often the P-3A¹ and the C-130¹; low-altitude aircraft, which operate below 15 000 feet; and, finally, the ground-truth platforms, which include boom trucks and boats. Helicopters are used for gathering ground-truth information in inaccessible areas, such as marshes and wetlands. Beyond those are a whole array of unique fit-the-situation type platforms. For instance, at our laboratory, we have one pirogue because a lot of our territory is too thick to drink and too thin to plow, and about the only way you can get there is in a pirogue. A pirogue is a small, shallow boat designed especially for bayou and marsh travel.

Figure 23 illustrates the array of sensors on the Earth resources experiment package on Skylab. The S190A is a six-band, multiband camera; the S190B is a

high-resolution, long-focal-length framing camera; the S192 is an 11-channel multispectral scanner; the S194 is a microwave radiometer; the S191 is a spectral radiometer; and the S193 is a radar device. In this symposium, you will hear presentations on virtually all of these sensors.

Figure 24 shows the two sensors on Landsat: the return beam vidicon (RBV) system, which has not been operated on Landsat-1 but is operable on Landsat-2; and a multispectral scanner, which is a four-channel device operating in the visible and near-infrared regions. The spectral range of Landsat sensors is shown in figure 25. The multispectral scanner covers the spectrum from 0.5 micrometer to 1.1 micrometers, and the RBV covers the range from 0.5 to 0.8 micrometer.

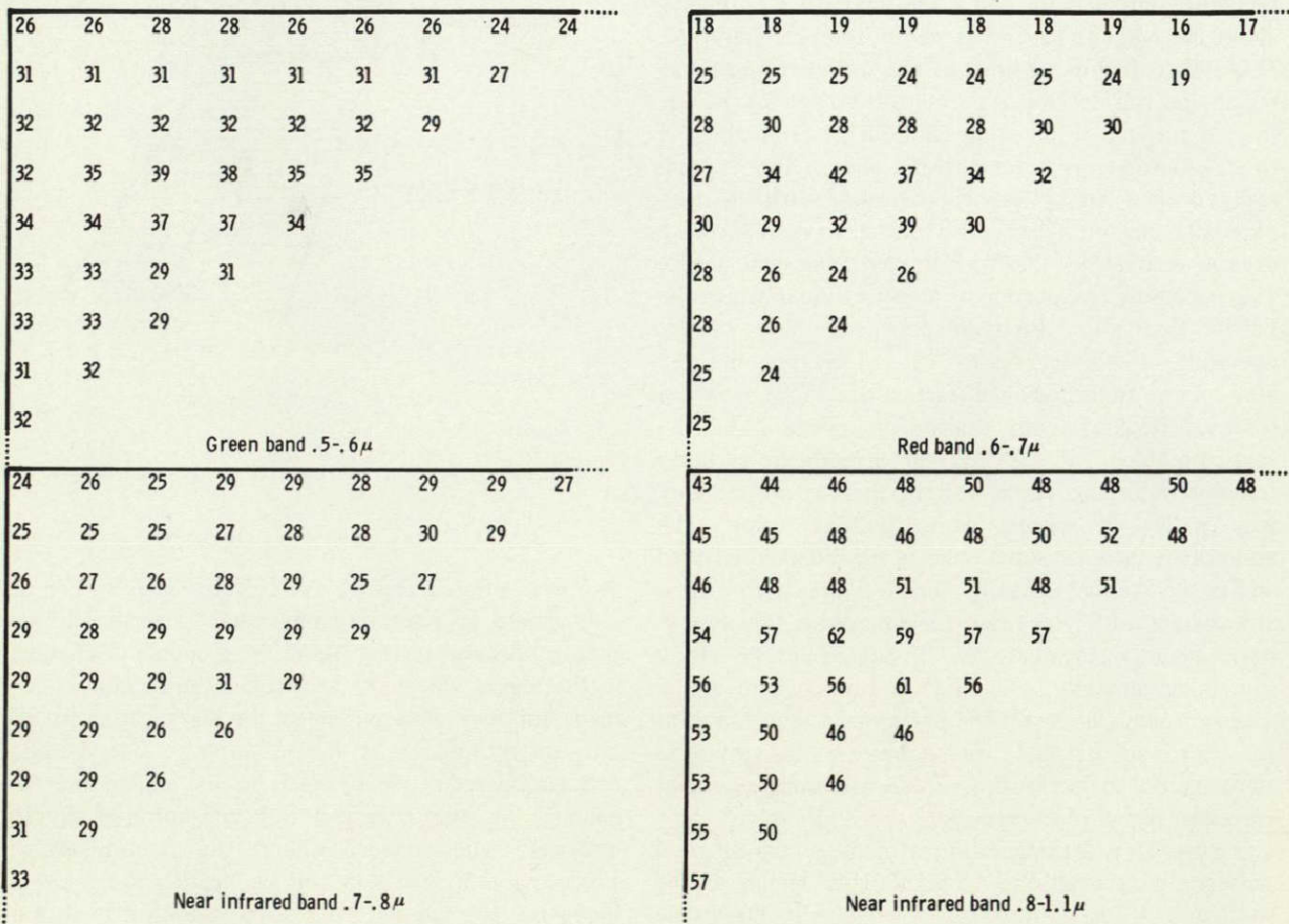

Figure 15.— Landsat-1 satellite digital data. These data were taken August 7, 1972, at an altitude of 570 nautical miles.

¹These have an increased battery of sensors because they are large, four-engine aircraft and can carry a lot of experimental sensor systems.

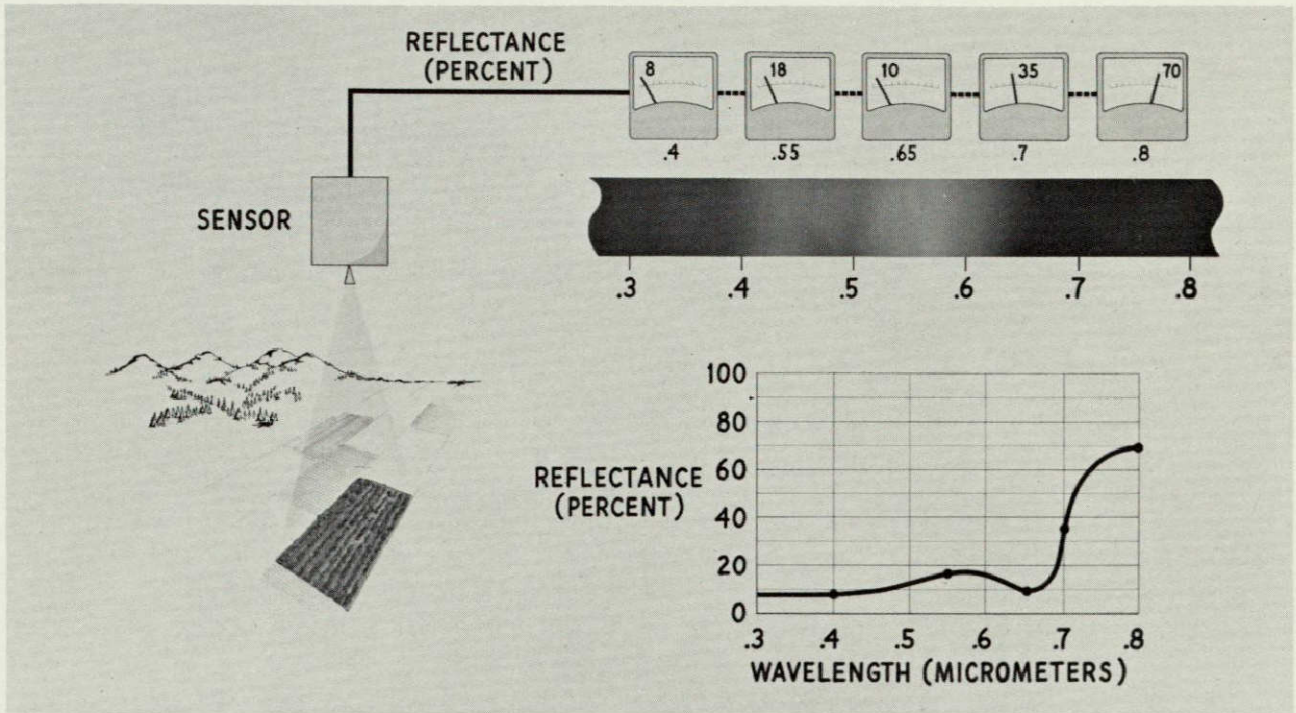

Figure 16.— The spectral signature of an object is a repeatable set of reflected energy levels at specific wavelengths.

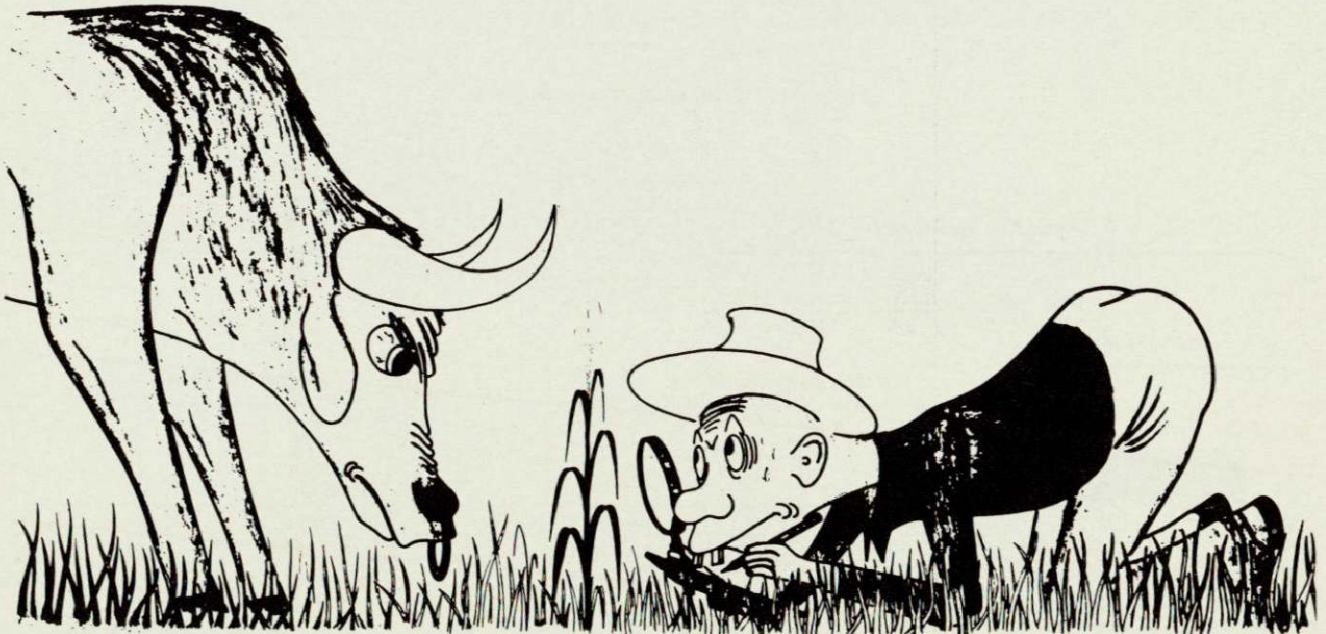

Figure 17.— Collecting ground truth.

REPRODUCIBILITY OF THE ORIGINAL PAGE IS POOR

EXAMPLES

PASSIVE SYSTEMS

THESE SYSTEMS RECORD NATURAL ENERGY SOURCES

CAMERAS



RADIOMETERS & SCANNERS

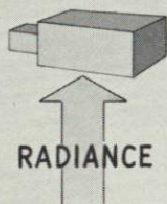

ACTIVE SYSTEMS

THESE SYSTEMS RECORD MAN-MADE ENERGY SOURCES

RADAR

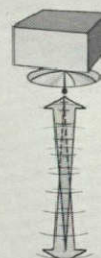

LASER PROFILER

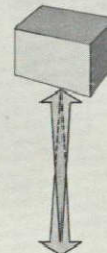

Figure 18.— Techniques of measurement.

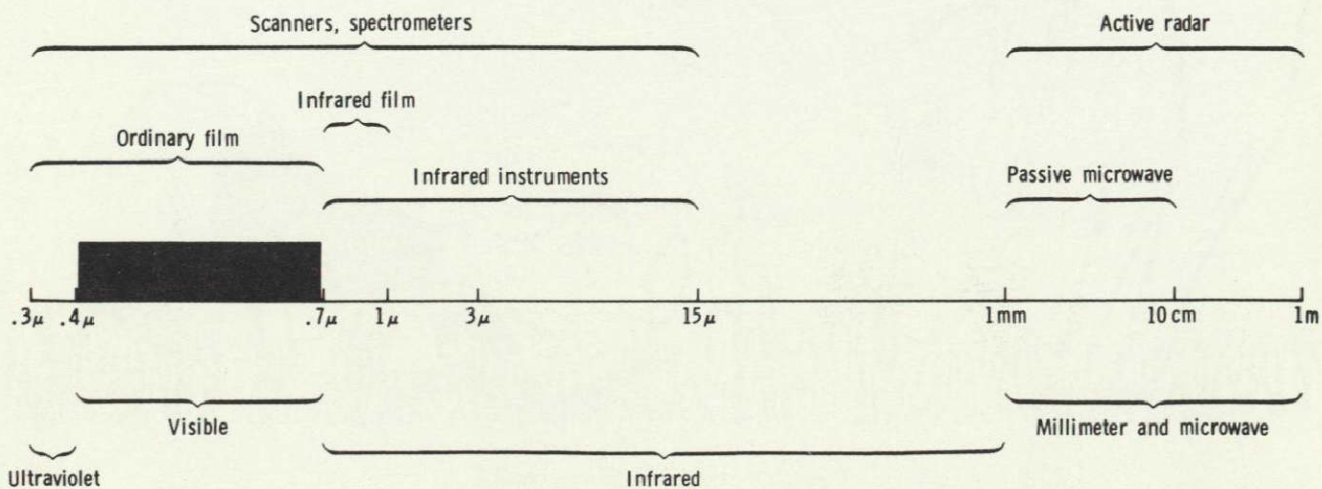

Figure 19.— Spectrum sensitivities of instruments.

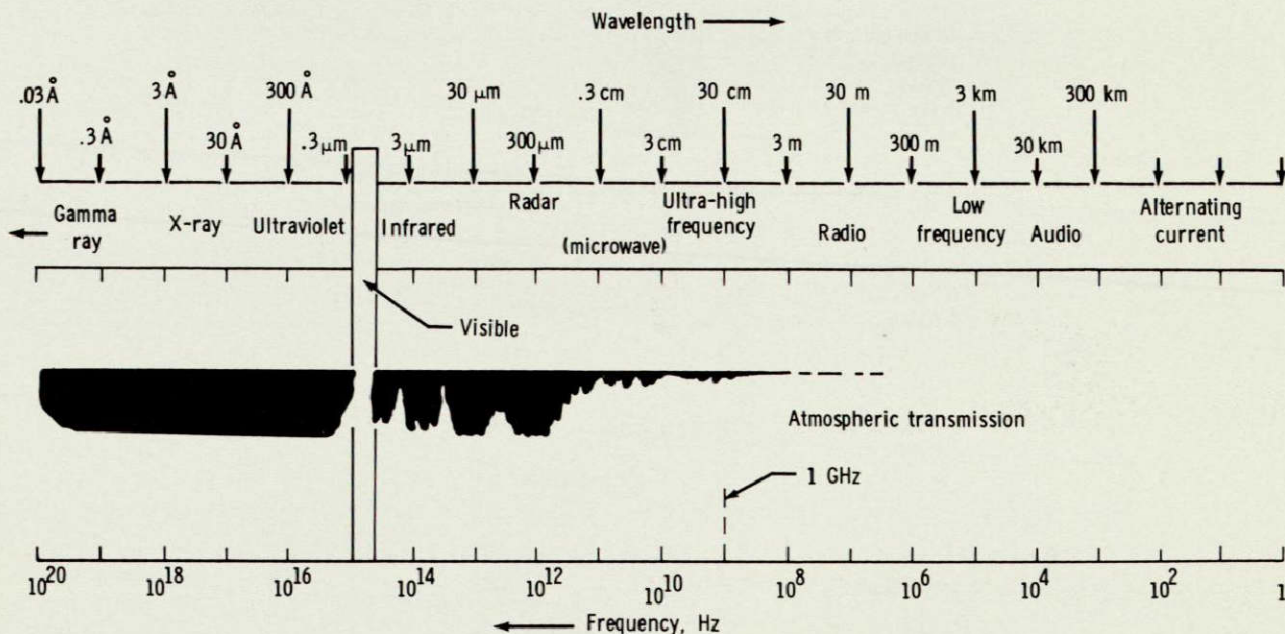

Figure 20.— Characteristics of the electromagnetic spectrum that are significant in remote sensing.

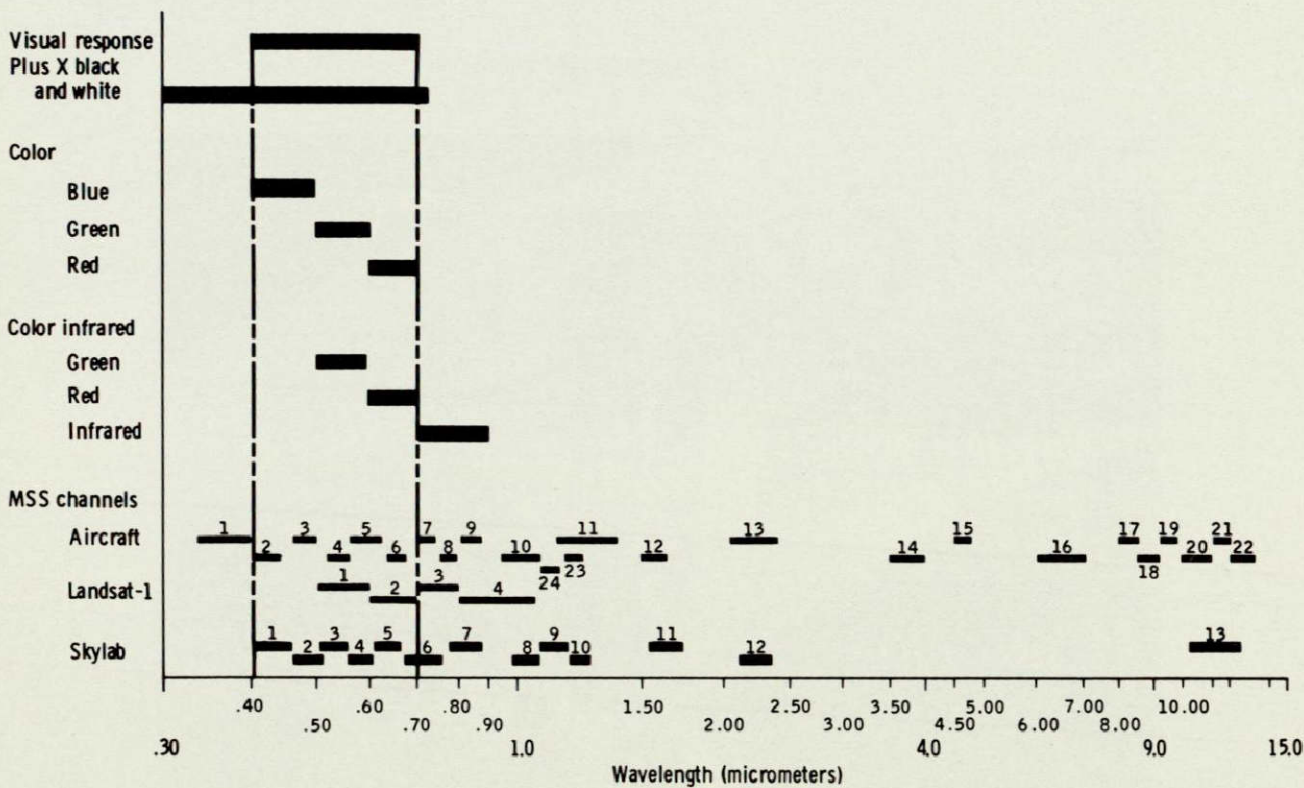

Figure 21.— Sensor spectral characteristics.

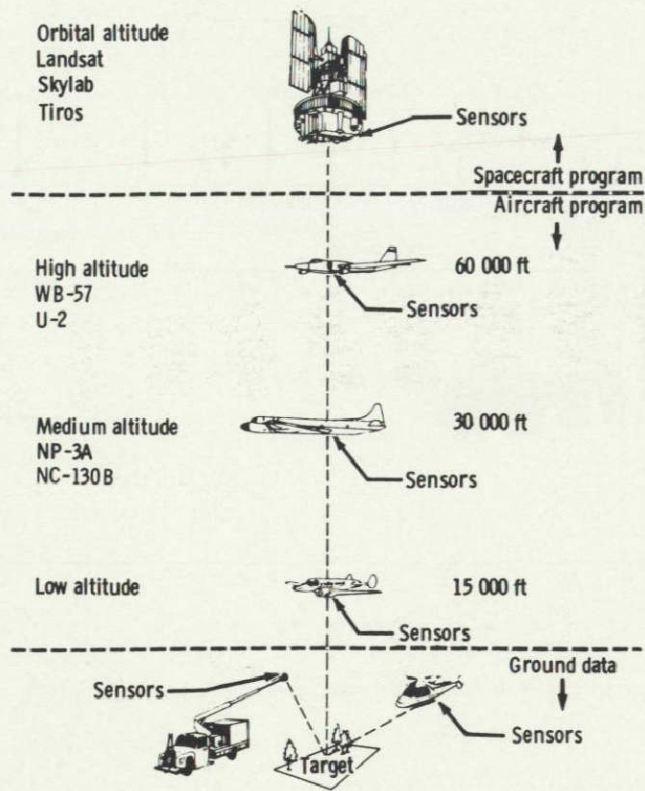

Figure 22.— Remote-sensing platforms.

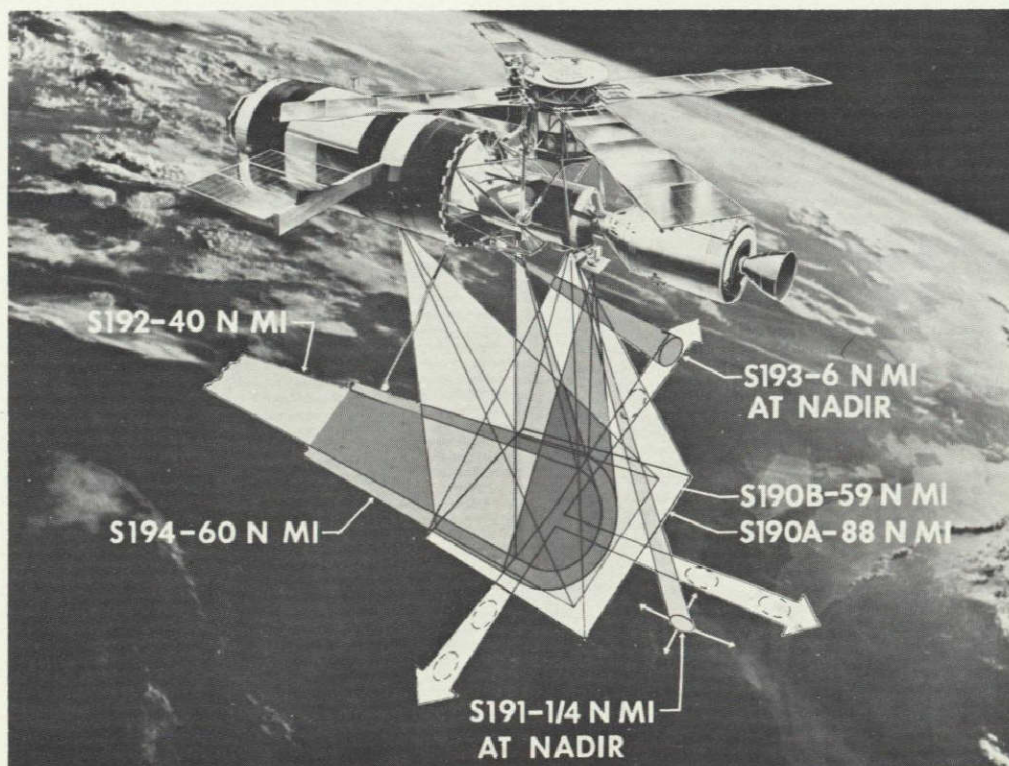

Figure 23.— Skylab Earth resources experiment package ground coverage.

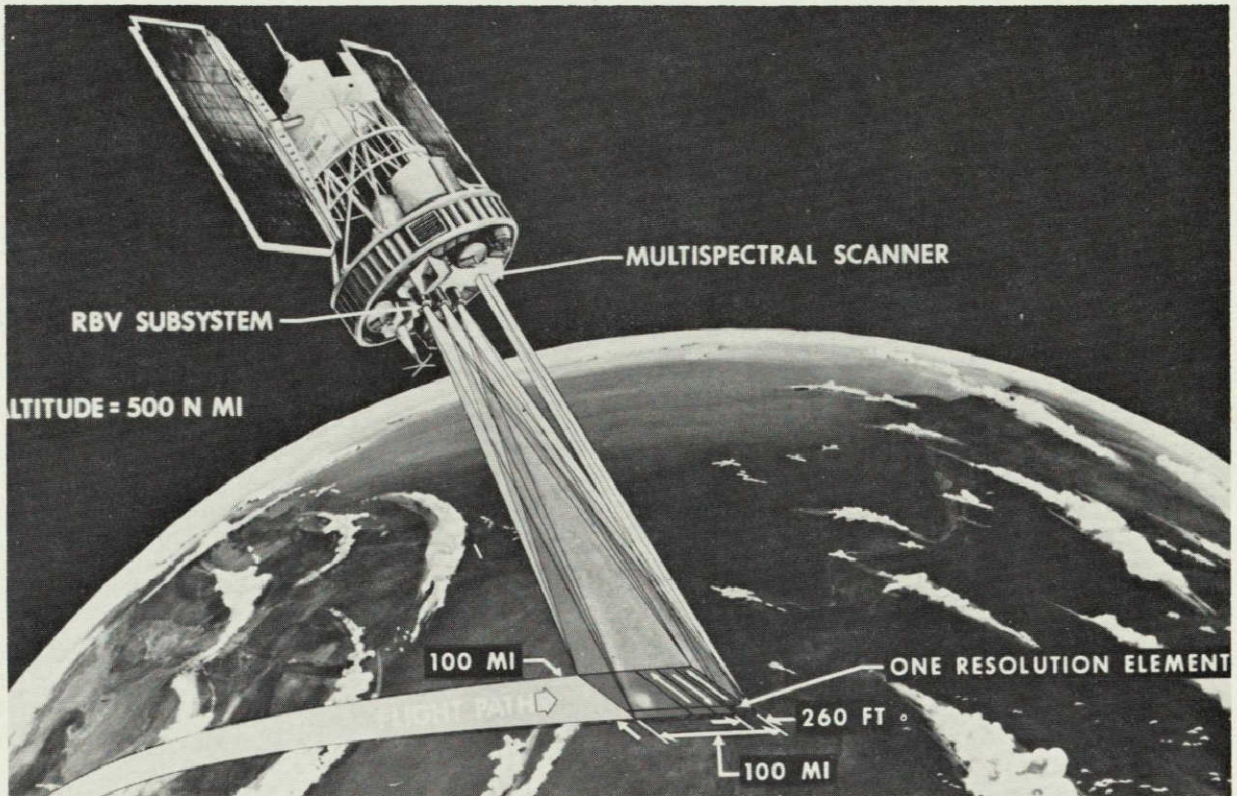

Figure 24. - Landsat sensors.

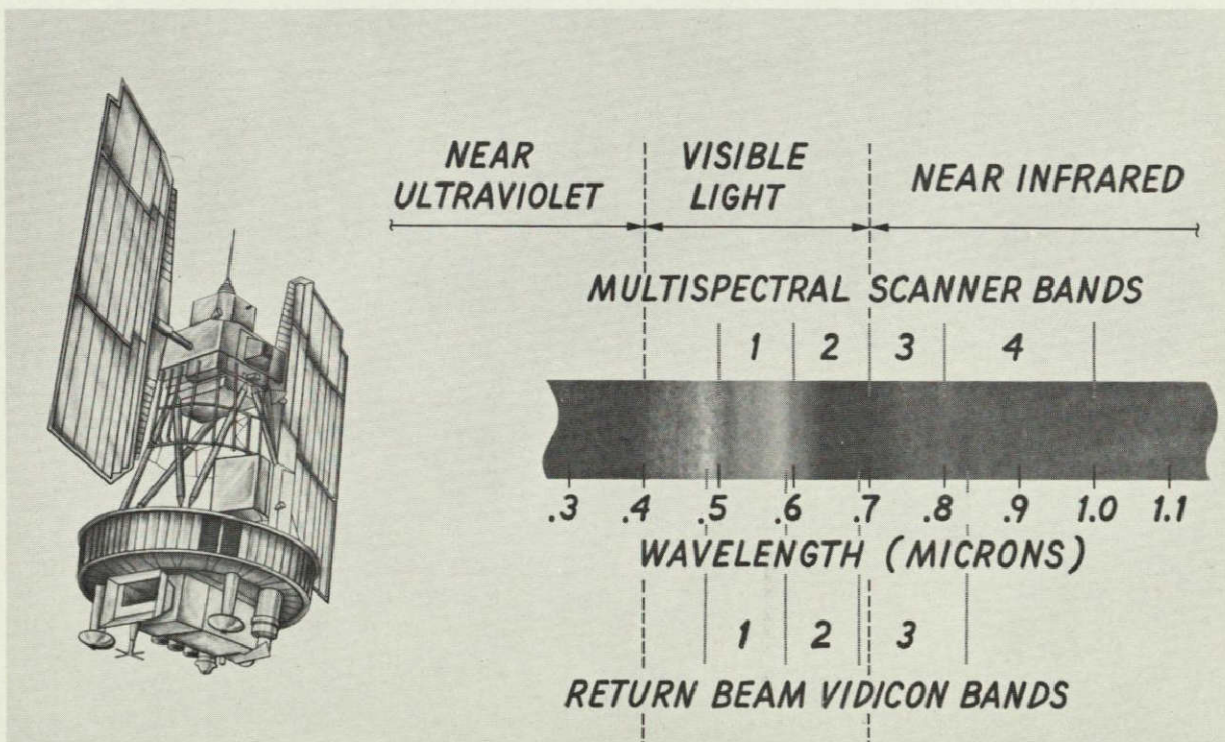

Figure 25. - Landsat spectral range.

Someone is always trying to design a single platform that will do everything for us, but as yet such a platform does not exist. With all of our advancement in technology, modern man now assesses his resources in a

modern state-of-the-art method using all sorts of remote sensors and data processing (fig. 26), and we hope we will get improved products that will help us better manage our resources.

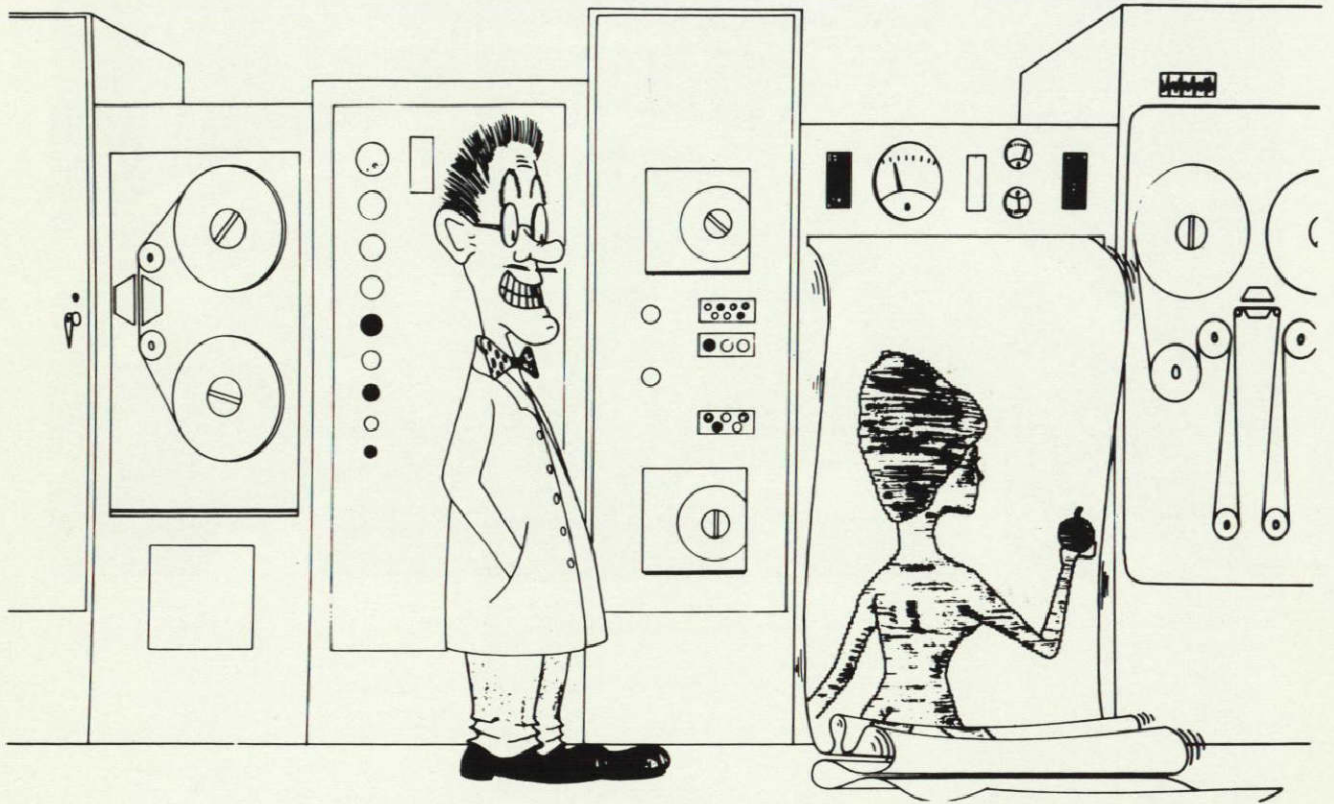

Figure 26.— Remote sensing: state of the art.

REPRODUCIBILITY OF THE ORIGINAL PAGE IS POOR

Applications of Earth Resources Technology to Human Needs

Caspar Weinberger^a

I am delighted for this opportunity to discuss the application of Earth resources technology to human needs, because in Washington these days there frequently appears to be some kind of built-in conflict between expenditures for scientific space technology (and sometimes defense expenditures) and the Government's domestic social expenditures. There appears to be a feeling by many in Congress, and elsewhere, that there exists a built-in disagreement between the two programs — a lack of compatibility between the two programs, an "either/or" type of situation. It has been my belief that a major and strong space technology program has enormous value for America, and one of the reasons is that the space technology program does help so very much in domestic social programs.

In Genesis, the Bible's story of creation tells how God, after completing His work, "saw everything that He had made and, behold, it was very good." This generation is the first ever to share that majestic sight. Through the achievements of space science and technology, we have, in one sense, become the masters of our cosmos, and we are privileged to look down from the sanctuaries that have been there over the centuries, over the eons, and see the whole sweep of the Creator's work. The question is, "What are we to do with this newly acquired vision?" This is one of the things that I want to discuss here, because some extraordinary things are being accomplished.

It is manifestly clear that man's mission in space is not to hurl down the thunderbolts of war from the heavens. His mission is to understand more fully the glories of creation and to use that knowledge in the peaceful service of mankind. Through the practical application of NASA's Earth resources spacecraft, we have learned how to use crop-damage surveys to increase the food supply for a hungry world; how to increase the forest products that shelter man; how to discover sources of pollution (almost before they start) that

befoul our land, our water, and our air; where to build nuclear plants safely; how to predict landslide-prone areas; and a host of other applications of advanced knowledge and skills that will allow man to make better, wiser, and more effective use of the bountiful gifts that nature has bestowed on us.

It is becoming urgently clear that we must learn to make wiser use of the bounty that we have. The reason is obvious. The world is now engaged in a major transformation in its development. We are discovering that population, energy, food, pollution, and physical resources are deeply interconnected parts of the single problem of how to survive on what some aptly call "the Spaceship Earth"; not only to survive, but to survive without causing damage so that future generations may have the same privileges or perhaps better ones.

This is not a new problem. However, it has become more urgent in a world where the population grows at the rate of about 79 million a year, while the finite resources are being used up at precipitous rates.

Audiences and readers are entitled to know something about the biases of their speakers and authors. One of my biases is that I am not a "doomsdayer." I do not believe we are heading for an apocalypse, and the reason is accomplishments such as those discussed here. Man, by using the intelligence bestowed on him by the Creator, is already wrestling with the vital equation of population and resources. However, once we have begun to solve this equation, we will have solved only half the problem. The other half will be to discover how to bring the benefits of our magnificent technology to as many people as possible, and we are making good progress on that half of the equation too.

Another of my personal views or biases is one that vigorously disputes the belief (which is gaining popularity among those who automatically follow what they believe are fashionable trends) that man's survival depends on his willingness to drastically cut his

^aSecretary, Department of Health, Education, and Welfare, Washington, D.C.

consumption and live what most of us today would regard as a Spartan existence. There is an effort to create an ethic which holds that "more is worse and less is better." This approach is a total reversal of the principles this nation has followed that have led to heights never before achieved. At the very least, I think there should be a careful examination of any such new doctrine before it is blindly accepted.

I have made what I consider a reasonable examination of this new policy, and I think it is totally wrong. To understand the fallacy of this approach, one must distinguish carefully between two concepts. One concept embraces the need for never wasting any resource and for making prudent use of the abundance provided. The other concept, which seemingly this new school of social thought has embraced, is one based on the assumption that, for all to survive, we must turn back the clock of human progress and live a marginal existence devoid of amenities. There is a distinction between the two concepts that we should not allow to escape us.

Many people base their belief of "less is better and more is worse" on the idea that we are a very wasteful people and that we have been prodigal in our use of resources. There is clearly a need to never waste any resource and to make the most frugal use of all the abundance given us. On the other hand, the idea of this new school that we can't accept is the assumption that we must turn back the clock of human progress and live a very marginal existence devoid of any amenities at all. This is a very fashionable view, and there are many people who are very critical of themselves, of their country, and of our whole way of life because they think that it is too abundant and that there is virtue only in being Spartan. A distinction must be made between the idea of not wasting, which is a perfectly sound and proper conservation principle, and the other idea of turning back the clock of human progress. By increasing production, we can make a better life for all.

It is perfectly possible (and wholly consistent) to be a conservationist and, at the same time, to appreciate fully the material blessings that economic growth and development have bestowed on this nation. It has become very fashionable to sneer at this growth of material blessings and to talk about them as the work of mammon and as something not spiritually sound. The ridiculousness of this thinking can be shown by asking ourselves, "How much adherence to this new philosophy would we have if some of its most vocal advocates were really placed in this Spartan existence?" It would not last long because most of them are people who have been enjoying the blessings of a very abundant society — and rightfully so.

What are some of the blessings? We have had a very remarkable history that, in recent times, has been overlooked and disregarded — or at least not regarded as it should be. Were we to condense the history of life on Earth to a single year and put that year on film, the idea and supreme achievements that we call America would not appear until the last 3½ seconds of that year-long film. How did we achieve so much in so little time? Some say that we appeared at a lucky moment in man's history, the dawn of the industrial age. That may certainly have something to do with it. Others say that the nation was blessed with an abundance of resources and logistical advantages that were not duplicated anywhere else. This is partly true. However, there is a third and even more powerful theory as to how this nation managed to achieve so much in such a short time. It is basically that we are a free people. This freedom is the real fuel of the whole dynamic economy; it is the fuel that no sheik can withhold from us because it is within us all.

This freedom has produced wealth untold, not alone for the rich, but across the entire country. Just 60 years ago, two-thirds of America lived in what we now consider substandard housing, and 90 percent of America was what we now call poor. Today, both figures are less than 10 percent; and that is too much, but it is a remarkable achievement. In worrying about trying to care for the 10 percent, we always tend to overlook the fact that we have accomplished a reduction from almost 70 percent to 10 percent in less than 60 years.

A hundred years ago, the infant mortality rate was very high; most women had their babies in homes. Today, 98 percent of the babies are born in hospitals with doctors in attendance, and the maternal and infant death rate has been cut to a mere fraction of yesteryear.

Since 1950, we have made it possible for 74 million people (one-third of the nation) to be enrolled in schools. Nine million are in college, more than double the figure in 1960. From the homes of our poorest (those earning from \$3000 to \$5000 a year) more than one out of every five enter college on various forms of public assistance, scholarships, or their own earnings.

We have produced, in one generation, the greatest miracle of upward mobility the world has ever known. Yet, we take it for granted and even indulge in heavy doses of self criticism because it isn't better. These are but some of the reasons why I am not a doomsdayer and why any American who has lived through this era of abundance should not feel any despair about the future if we keep faith with the basic freedom that served as the principal ingredient in achieving these great accomplishments.

Many can deride these accomplishments. That is also part of the American tradition, and we must jealously guard their freedom to do so. However, I am one who is very proud of these achievements and not ashamed to say so. I am one who feels that they reflect the will, the spirit, and the humanity of a great and compassionate nation. More than that, these achievements reflect the ability of this nation to achieve such things — achievements accomplished by a nation that has as its hallmark the idea that man should be free to follow his own bent as far and as fast as it carries him, so long as he interferes with no one else in trying to do the same thing. A nation such as ours will never rest as long as there are such deficiencies as a single hungry child, one poverty-stricken family, or an elderly couple who is living in despair. These are the challenges ahead — may we never shirk them. And we never will.

In recognizing these challenges, it is especially important that we do not forget that America was the kind of country which made this enormous progress in a very short period and that nothing about the country has fundamentally changed to deter or to weaken its compassion or humanity. However, a great many people believe that doomsdaying is the “proper thing.” This kind of thinking is fashionable and very much like the people that Gilbert and Sullivan spoke about. “They never think of thinking for themselves at all,” that perceptive pair of social critics noted long ago. This kind of people just follow someone else’s thoughts, and that is not the thinking that will benefit the country or world very much.

As just one measure of America’s humanity and compassion, the country spent \$336 billion in 1974 alone to feed, to house, to clothe, to educate, and to care for people in need. Since 1950, the median (disposable) income of the American family has doubled, even with inflation fully taken into account. Since 1950, our nation has built, from scratch, a suburbia of 35 million homes that contains more furniture, telephones, televisions, vehicles, stores, libraries, schools, public services, and roads than have been accumulated in centuries of efforts by other advanced nations. It is easy to say that some of these things are not very useful, but I think we can make a very good argument that every one is useful. It is not just the affluent who benefited; the people of middle incomes and the poor have benefited from this productivity and our compassion for each other.

This achievement has come about far faster than any other era in the world’s recorded history. This is not the work of a decaying ideology or a system that is no longer great. Whatever adjustments that future needs

require, we will be equal to the task; and we will still be capable of bringing about the really outstanding results that have occurred in the last 25 years, last 10 years, or any historical period you select.

We are now forging the changes and discovering the technology that will see us through another era of equally bright promises and aspirations and that will reveal an equally golden future for the people whose fortunes may not be so great and whose worries may be considerable right now. These productive uses of space technology did not come about accidentally. Back in the 1950’s, when the future conquest of space by man was envisioned, our leaders set the direction of the challenge. In a message to the Soviet leaders in January 1958, President Eisenhower proposed “that we agree that outer space should be used for peaceful purposes.” A few months later, he declared to Congress that “a civilian setting for the administration of the space function will emphasize the concern of our nation that outer space be devoted to peaceful and scientific purposes.”

A very dramatic illustration of this objective is the Applications Technology Satellite 6 (ATS-6) that was launched just last year (May 30, 1974). Its technology and accomplishments are astonishing. The ATS-6 has been used to deliver educational and health services to more than 100 isolated communities in the Rocky Mountains, Appalachia, and Alaska. This satellite is the most powerful communications satellite ever sent into space. Its signals do not require elaborate and costly ground antennas, but can be received by receivers costing less than \$4000. This means that satellite programing can be delivered to a community at a cost less than the yearly salary of a school teacher, yet it can benefit thousands of people in the education field alone. Its tremendous health benefits far exceed any fiscal considerations. Thanks to ATS-6, specialists in hospitals as far away as Anchorage have seen patients in isolated Alaskan villages who have never seen a doctor, have never seen a nurse, have never seen any kind of medical person. Some will say, “It’s not as good as a face-to-face consultation,” and I think that is probably true. However, it is vastly better than anything these people have had in the past or can have for generations to come. It offers a great deal of promise for similar situations throughout the world. A dramatic illustration is a baby girl who was being treated in an outlying hospital in Alaska for recurrent fever, appetite loss, and diarrhea. The illness might have been flu, but it was not. She was taken to a hospital that could receive ATS-6 transmissions, and a distant medical consultant diagnosed her case as tuberculosis. Following treatment,

she is now back in her village and is monitored regularly by satellite transmissions.

Experiences like these only hint at the possibilities of delivering health, education, and welfare services by satellite. That hint has been enough to prompt the formation of a Public Service Satellite Users Consortium, a national organization of health and educational groups that believe they can use and pay for a special high-power satellite communication service. Of special importance, this technology can be available at very low cost and can serve millions of people on a basis never achieved before. It applies to education, to the training of teachers in remote areas, to disseminating information from professional meetings to those unable to attend, and to a host of other applications limited only by man's imagination.

Prospects are sufficiently encouraging that the Department of Health, Education, and Welfare (HEW) is now developing a plan for Federal encouragement of a nationwide telecommunications system to meet the varied needs of the health and education communities. This system might include a social services satellite interconnecting with cable television and public television. It would be able to reach almost every community in the nation, no matter how remote, by means of inexpensive receivers on the ground. The administration is now proposing legislation to foster this kind of system, which would help the nation develop more efficient and economical ways of delivering social services. Economy of the services is important because our fiscal resources are also finite. It is important that we stay within these resources and to take steps where necessary to avoid the Federal Government traveling the road that led New York City to its near disaster. Economic factors must be considered, but these considerations need not lead to a sterile negativism. They can lead to technology like the ATS satellite by which scientific applications are made at very low costs and results are perhaps more effective than those achieved at much higher costs.

As head of the largest of the Government departments, I am very grateful to NASA. As an American citizen, I am grateful to NASA and the space programs for a great many things:

1. The enormous, useful, and vital technologies that have evolved from the space program
2. The opportunities that arose to demonstrate that America could rise up and meet an enormous challenge
3. The really great sense of pride that the space program gave to America at a time when we urgently needed to feel pride in our country
4. The heroism of our astronauts at a time when

America desperately needed some heroes and someone to look up to and admire, at a time when the strange twists of history had made it unfashionable to acknowledge heroism or its possibility

Our conquest of space may well be the very first step in restoring our boundless belief in ourselves and in our own abilities. It may be the first step in restoring the capability of solving the problems of our future, a capability that has energized this country through most of its great history.

From this vision of space, we have gained new hope for the future of our Earth. We are living in a time when dreams can come true. First, there was the restless dream of flight — an age-old dream from the time of Icarus. Then came the daring dream of space. Today, the reality of these dreams has given us a new dream, a dream of being able to reach out to one another, to reach anywhere on this planet where there is human need and help to solve it with this enormous and staggeringly complex technology that has been mastered. To grasp that dream, we must reach out and seize opportunity now, risks notwithstanding. There will be risks of failure, and there will be risks not yet known. Alfred North Whitehead said: "Modern science has imposed on humanity the necessity for wandering. Its progressive thought and technology make the transition through time . . . a true migration into uncharted seas of adventure. We must expect, therefore, that the future will disclose dangers. It is the business of the future to be dangerous; and it is among the merits of science that it equips the future for its duties." This is one of the reasons that the space program, as viewed by many, has had so many delays, though this connotation is not true at all. The space program was trying to guard against and prevent the unknown risks that can scarcely be seen; we have been remarkably successful in that effort.

The beginning of America's third century can be and will be gloriously launched. America will be able to harness the nation's needs if its people can harness their talents, wealth, and resources. More than that, we must harness America's resolution, will, and boundless confidence in its own ability to solve these problems. In contrast, we could devote ourselves to cataloging all the things that are wrong and all the deficiencies that are found; we could then conclude that the only counsel for the future is a counsel of despair. We have a glorious destiny during the third century. Realizing this destiny depends on whether we approach it in the same boundless spirit of optimism, energy, skill, talent, and devotion that we devoted to the first two centuries of our history. I don't have the slightest doubt as to the outcome.

Department of the Interior Programs

James R. Balsley^a

The Department of the Interior (USDI) has the responsibility of being the biggest landlord in the United States. About a third of the United States is under the control of the Federal Government, and we are responsible for conserving and developing the mineral and natural resources; conserving, developing, and utilizing our fish and wildlife resources; reclaiming arid lands; and administering the Nation's scenic and historic areas — an awfully big job to do in a lot of country. For years, we have been looking for better ways to meet our responsibilities; obviously, remote sensing is one option. The Department of the Interior has been interested in remote sensing since the first camera was put in an aircraft. In fact, some of our geologists and mapmakers have been accused of doing a little too much remote sensing when they did some of their early surveys by using binoculars from a mountain top. So when the opportunity to get a repetitive look at the United States from a more distant view became technically feasible, about 10 years ago, we quickly began to initiate cooperative programs with NASA. The USDI established the Earth Resources Observation Systems (EROS) Program and, working with NASA, other Federal Government agencies, and state and local agencies, we helped develop the specifications for the first Earth resources technology satellite. The Interior program now has an annual funding of about \$12 million, of which \$8 million is directly appropriated to the EROS Program, and \$4 million is from funds directly appropriated to other units within the USDI. That is \$4 million worth of user interest, which is a significant amount of interest.

When I was asked to summarize the Landsat activities of the Department of the Interior, it seemed like an almost hopeless job. When I looked at the program of this meeting, I saw that most of the activities would be discussed in the technical sessions, making a summary even more repetitious. I have just finished reviewing the galley proofs of "ERTS-1, A New Window on Our Planet,"¹ a book edited by R. S. Williams, Jr., and W. D. Carter describing the Landsat activities of USDI, and it

occurred to me that a quick look at this book is the best way to review the Interior's interest in satellite operations to date. I would like to read from Dr. V. E. McKelvey's foreword in which he states, "... The ERTS spacecraft represent the first step in merging space and remote-sensing technologies into a system for inventorying and managing the Earth's resources. This development is a good example of applying the scientific and technological methodology gained from the Nation's space program to the solution of global environmental, natural resource, food, and energy problems. Evidence in hand strongly suggests that the ERTS spacecraft are central to one of the largest and most significant Earth science experiments ever undertaken.

"Examples presented in this book demonstrate ERTS' vast potential for inventorying resources, monitoring environmental conditions, and measuring changes. Such information is essential for the full evaluation of the Federal lands and determining their future use, as well as for improved planning of overall land use throughout the United States and the world.

"More than being merely another scientific experiment, this undertaking is a multinational, multidisciplinary experiment on a global scale. Approximately 100 nations are participating, and it is believed that the program will contribute materially to achievement of an objective basis for setting interrelated resource, environmental, and social priorities for much of the world.

"Data from the U.S. Earth resources survey satellites are of help to all nations in coping with national resource and environmental problems. This is so because we have only rudimentary knowledge of our resources. Even more limited is our knowledge of the effect of development and consumption of these resources on the long-term future of our planet. Thus, we are restricted in our ability to make the decisions necessary for the wisest possible utilization and conservation of the resources upon which we depend for our very existence."

The Landsat activities program in USDI involves 10

^aU S. Geological Survey, Washington, D.C.

¹U.S. Geological Survey Professional Paper 929, published in 1975.

agencies, including the Bureaus of Indian Affairs, Land Management, Mines, Outdoor Recreation, Reclamation, and Fish and Wildlife Service; the Bonneville Power Administration, National Park Service, Office of Trust Territories, and the Geological Survey. So it is a program wherein we are making use of the satellite to help the Federal Government manage our land. The fact that the bureaus are now using their own funds, in some cases, to support this work is solid proof that the techniques that have been developed are appropriate for their operational utilization.

The Landsat book is divided into chapters in almost the same way this conference has been organized. In the chapter on cartography, the most significant point is that the cartographers were originally very doubtful that the scanners would ever be of any use for mapping because modern cartography depends on the metric, frame camera. Cartographers have now shown by various experiments that Landsat data have unique advantages. There are the obvious advantages of large areal coverage, of real-time data, and, in a quote from Dr. Colvocoresses, "Although the internal geometric accuracy of the MSS may not be as great as that of a good mapping camera, the accuracy it does have, when coupled with the external advantage of the continuous, near-orthographic view, results in two-dimensional (planimetric) mapping of geometric precision which may well exceed that obtainable from camera systems under like conditions." Now, when a long-time professional cartographer says this, it unambiguously means that Landsat is a valuable cartographic tool. Landsat also has the advantage, through the use of computer-compatible tapes, of being able to do certain types of automated planimetric and thematic mapping.

In summary, then, from the cartographic viewpoint, Landsat has far exceeded expectations. Again, let me quote from Dr. Colvocoresses, "For the first time in history, cartographers have the source of material from which image maps of small scale can be produced efficiently and accurately. Moreover, ERTS has introduced a revolutionary concept, automated mapping of the Earth." You all have probably seen some of the actual map products, but I would like to mention one prepared by the Bureau of Land Management. It is a digital color mosaic of eight images of part of Wyoming and Montana at a scale of 1:1 000 000. The image map will be used as a base map for terrain and water studies, and to monitor changes caused by strip mining and reclamation of mined areas. There are also the new state image maps of Florida, Arizona, and New Jersey.

The discipline of geology is naturally one of high interest to the USDI, and it does have the added

attraction of exploration and discovery of ore deposits and petroleum resources. Furthermore, the original design of the satellite included instrumental specifications and orbital time for use in geological studies. The design criteria depended heavily on the hypothesis that large structural and tectonic features were present on the surface of the Earth. Because of their regional size and subtle expression, these features have gone unrecognized in conventional ground and aerial surveys. It was expected that these hypothetical features could be seen on images having sufficient areal coverage and uniform solar illumination. These features were of more than passing interest to geologists because they may possibly be guides to discoveries of new metal, oil, and gas deposits.

I would like to bring to your attention a couple of Geological Survey projects in which the location of ore deposits is a little more obvious. When you are looking at large structural features, there is always the need to correlate the remote-sensing analysis with other geological and geophysical information. Sometimes, by also looking at the spectral response, we can almost locate mineralized ground directly. Robert Schmidt, who presented a paper at this symposium ("A Search for Sulfide-Bearing Areas Using Landsat-1 Data and Digital Image-Processing Techniques," included in the summary sessions, volume II-A), has made a computer printout of Landsat data to help outline five potential copper deposits in Pakistan, using known copper deposits near Saindak as a control area. Schmidt used a computer to determine the spectral signatures within known copper-bearing mineralized zones. Whenever these same signatures showed up elsewhere on Landsat images used in the experiment, distinctive symbols appeared on the computer printout. Schmidt then made ground inspections. We never can locate ore deposits directly from satellite data; but this is about as close as we can come.

Another area of interest is the so-called "sand seas" of the Earth's desert areas. These are often vast areas with abundant sand which moves about in a variety of ways. Ed McKee's work is more basic than applied research, but it is of interest in our fundamental understanding of the occurrence of oil in sand formations, which had a similar genesis.

For the Department of the Interior, I think the real payoff has been use of the satellite imagery and computer-compatible tapes to do repetitive monitoring of dynamic environmental phenomena related to water resources. We know there are 10^{18} tons of water on the Earth, and there are 20 000 gallons of water per person in the air. But we only need, on the average, 1600

gallons a day for each person. The problem is, however, that water is not always where people are. The management of our water resources, that is, the identification and evaluation of them, has been very aggressively attacked by many scientists using Landsat imagery and/or data collection platforms. I am sure that many of you have already heard papers on this subject at this symposium, but I would like to emphasize a project which is being done in the Everglades National Park area and environs, south Florida (W-16, vol. I-D). This is a cooperative program of the U.S. Army Corps of Engineers and the Geological Survey. It is a hybrid, quasi-operational experiment, using satellite imagery (both images and computer-compatible tapes) and data collection platforms. The data platforms are used to measure the depth of water in water conservation areas, and the images are used to determine the areal extent of the water. From these two sources of data, the volumetric estimate of available water can be derived. Results of this ongoing and near-real-time investigation provide information to water managers, assisting them in making a better determination of the optimum distribution of water between metropolitan Miami and the Everglades, thus helping to maintain the unique ecology of the national park.

In a related study by the Bureau of Reclamation, seven data collection platforms have been sited in the San Juan Mountains of southwestern Colorado to evaluate the results of cloud seeding experiments. Some of these data collection platforms have been subjected to winds of more than 60 stat. mi/hr (96 km/hr), others to burial under 50 feet (1500 centimeters) of snow, and all to extremely low temperatures. Of the seven, only one was incapacitated; it was struck by lightning. These platforms have been monitoring precipitation, temperature, relative humidity, insolation, ice riming, wind direction, windspeed, snow water content, and streamflow data. During the spring of 1973, when spring snows created the possibility of floods in the valleys below, proponents of the cloud seeding experiment, Project Skywater, suspended the seeding project. The decision was based, in part, on timely information provided by the Landsat data collection platforms. Here, again, is a well-documented case of a significant application by a government bureau having a large land-management function. There have been numerous papers presented at this symposium, or published elsewhere, on the water resources monitoring aspects of Landsat: the identification and measurement of flooding, the identification and measurement of coastal and interior wetlands and irrigated lands, location of ground water recharge areas, studies of the movement of

surging and normal glaciers, measurement of areal snow cover, et cetera. All of these represent dynamic environmental phenomena, most of them inadequately monitored, if at all, prior to the availability of Landsat data.

A significant session was held here on the use of Landsat and Skylab data in land use mapping, and, as you know, the Geological Survey has a Land Use Data and Analysis (LUDA) Program, which is charged with preparing land cover maps and various data sources of the entire United States on a compilation scale of about 1:125 000 within 5 years. We now have available remote-sensing capabilities to effectively map the land cover of the entire United States at small and medium scales within a reasonable time frame compatible with the needs of at least some of the people engaged in land use planning management, regulation, and research. Remotely sensed data received from Landsat-1, from high-altitude aircraft, and from other sources will provide a land use data collection system capable of providing a cost-effective and, with some of these data acquisition systems, timely and periodic updating of such land cover data, in order that the dynamics and trends in land use can be studied effectively. A quote from the Association of Planning Officers: "Of all the factors that determine the quality of our environment, the most fundamental is the use we make of our land." The first thing we have to find out is how we are using it. Of course, this is of interest to the Geological Survey, the Bureau of Land Management, and the Bureau of Indian Affairs. The latter two agencies have jointly developed a computerized resource management system using Landsat imagery, and they are now moving from the design stage to the actual testing on two areas, the Quinault and the Rosebud Indian Reservations.

I have only touched on the resource management area, and I know that scientists and administrators from the Department of Agriculture will be discussing this topic in some depth. The area of agriculture and forestry is one in which resource management is much involved. The Interior Department, through its Bureau of Land Management, is vitally interested in rangeland management, and one of its scientists, Gordon Bentley, is performing a study to determine methods for obtaining maximum use of the seasonal yield of forage. Environmental monitoring is another important area, and the USDI is working closely with the National Oceanographic and Atmospheric Administration (NOAA), monitoring many types of environmental phenomena. Bureau of Mines scientists are looking at air pollution from fires and are studying the air pollution in the Ohio and Monongahela River Valleys.

Al Strong of NOAA has been studying algal blooms and turbidity in Utah Lake. The Fish and Wildlife and the National Park Services are very interested in conservation of wetlands and archeological sites, respectively. Tom Lyons of the National Park Service has studied the history of the ancient Pueblo tribes by examining the regional ecological setting of the ruins at Chaco Canyon National Monument, New Mexico. Satellite imagery has been used to relate an ancient Pueblo roadway system to the distribution of natural resources and, thus, to enable the Park Service to better understand the culture of these ancient tribes. The Park Service is also interested in the Cape Cod National Seashore and is using satellite imagery to show the

natural ecology over the entire park area and the dynamics of the coastal zone. Satellite imagery is being used in Yellowstone National Park to study land use to determine the best use of the park area. At the Interior's EROS Data Center in Sioux Falls, we maintain a training and assistance center for the general public, and duplicate and distribute Landsat imagery.

This has been a brief and general summary of just a few of the Department of the Interior's Landsat activities, but I hope that, in Dr. McKelvey's words, "you will agree with us that we have made a fine start in the effective and beneficial use of space for all mankind."

U.S. Army Corps of Engineers Programs

John Jarman^a and K. E. McIntyre^a

INTRODUCTION

The previous presentations have provided ample evidence of the potential application of remotely sensed imagery. I will not talk about what the Corps of Engineers has done since the inception of the Landsat program, but what we expect to be doing operationally with satellite remote sensing within the next decade. I am sure that many important applications will develop which we, in the Corps, have not anticipated; therefore, my comments will be confined to a few of the more obvious applications that we are using.

The Corps of Engineers has several missions, including military construction, military engineering, mapping, real estate for Army and Air Force, and civil works. I will focus on the civil works mission, which covers our responsibilities in water research development. The civil works activities of the Corps of Engineers include navigation, flood control, beach erosion control and hurricane protection, and other related projects to protect and preserve navigable waters, fish, wildlife, and recreation. The Corps publishes statistics on water commerce and institutes emergency operations in the event of floods or other disasters.

REMOTE-SENSING TECHNOLOGY IN HYDROLOGIC STUDIES

Remote sensing has been used for a number of years in the Corps' aircraft programs. Today, we are using it in geologic studies for site selection and for location of construction material. Remote sensing is providing land cover information for project planning and for environmental impact assessment. Remote-sensing data collection is a new technology, and we are still using data collected by conventional means to supplement it. Our goal is to incorporate remotely sensed data directly into the decision process, as shown in figure 1. Before we can do this, people must have confidence in

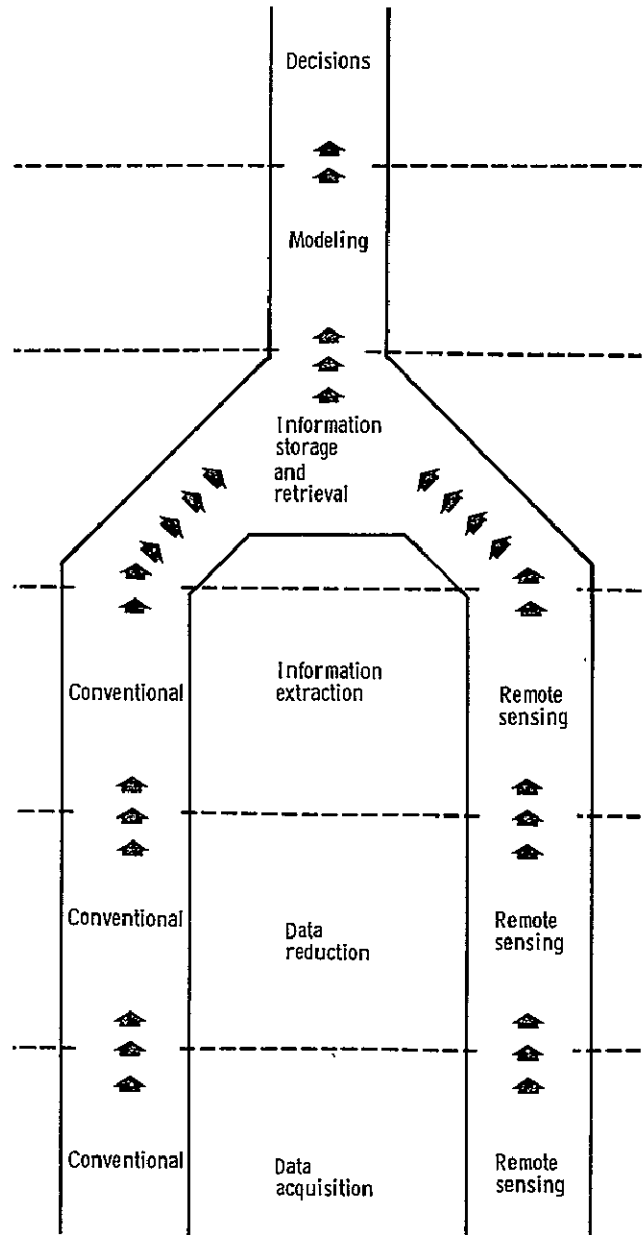

Figure 1.-- Incorporating remote-sensing data into the decision process.

^aU.S. Army Corps of Engineers, Washington, D.C.

remote-sensing data and begin to use them. For this reason, I think that the major emphasis in our program in the next few years will be to introduce automatic classification of multispectral data directly into our models without going through the hard-copy operation, as was done previously. Figure 2 is an example of a hard-copy map produced from remote-sensing data.

Because our mission is in water resources, hydrologic studies are of major importance. We are devoting a great deal of effort to developing modeling techniques for solving operational and planning problems related to the analysis of hydrologic systems, reservoir system analysis, quantity and quality of runoff from urban areas, water quality in rivers and lakes, river hydraulics, and sediment movement. These models incorporate physically based components of the hydrologic system such as a loss-rate computation. These components, in turn, use physical parameters and constants determined empirically to fit recorder input-output relationships. Remote sensing can be used to estimate the physical parameters presently used in the models. We can also begin to substitute physical values obtained from remote sensing for the default values frequently used because we cannot afford to collect photographic-type data. In addition, as we develop confidence in remote sensing, we will see many physical values replace constants because we have no way to accurately collect the physical data. Examples of parameters used in our models include impervious surface fraction — the fraction of total watershed from which runoff contributes directly to a stream; vegetation interception rate — rate of rainfall interception by watershed vegetation; and water surface fraction — fraction of total watershed covered by water surfaces at normal low flow. All of these parameters can be obtained by the automatic classification of multispectral data.

We are able to determine the probable level of flow in a river under varying hydrologic conditions. But as the development in the flood plain changes, the hydrology changes also. We must continually review our designs to determine what the changes will cause in terms of flow and its effect in the overflow and runoff areas in the flood plain (fig. 3). Figure 4 shows a multispectral classification of the Oklahoma City area. We are using this to delineate the problem areas around Oklahoma City. In the future, we hope to be able to use this kind of data to change the land use that is shown on the present classification, feed the data into the model, and predict the changes in the hydrology.

REGULATORY PROGRAMS

Another area of major importance to the Corps of Engineers is the regulatory program. For many years, the Corps regulated construction in navigable waters by determining whether proposed construction in the waters would interfere with navigation. This program has undergone tremendous change in the last 6 to 7 years. It has progressed from a point where the only consideration in evaluating an application for a permit was the effect of a proposal on navigation to a point where the broad spectrum of the public interest is evaluated in reaching a decision to issue or deny a permit. Along with the growth of the permit program, public involvement has also mushroomed to the point where almost every permit action has active, public participation. Therefore, the Corps is undertaking a surveillance and enforcement program to control unauthorized activities in the waters of the United States, including adjacent wetlands. To enhance our surveillance capabilities, remote sensing will be used to develop a change detection program.

Increased activity on the outer continental shelf (such as oil drilling, superports, nuclear powerplants, and artificial reefs) is causing the little known and infrequently exercised Corps permit authority contained in the Outer Continental Shelf Lands Act of 1953 to become very important. This act extends the authority of the Secretary of the Army to prevent obstructions to navigation in navigable waters of the United States by artificial islands and fixed structures located on the outer continental shelf.

This responsibility relates closely to the mission of the Corps in coastal areas. We attempt to predict the reaction of the ocean to structural alteration. One of the parameters in which we use remote sensing is monitoring sediment movement. If we can acquire information on this phenomenon, we can help in the design of more effective navigation structures, reduce damages on our coasts, and preserve our recreation resources. Figures 5 and 6 are examples of catastrophes which might be eliminated with the acquisition of more information. Figure 5 shows a small harbor entrance that shoals up quite rapidly because the jetties are unable to keep the sand out. As a result, increased maintenance and operation costs are incurred. Figure 6 shows what could happen when people build along the coast with inadequate knowledge about the selected area.

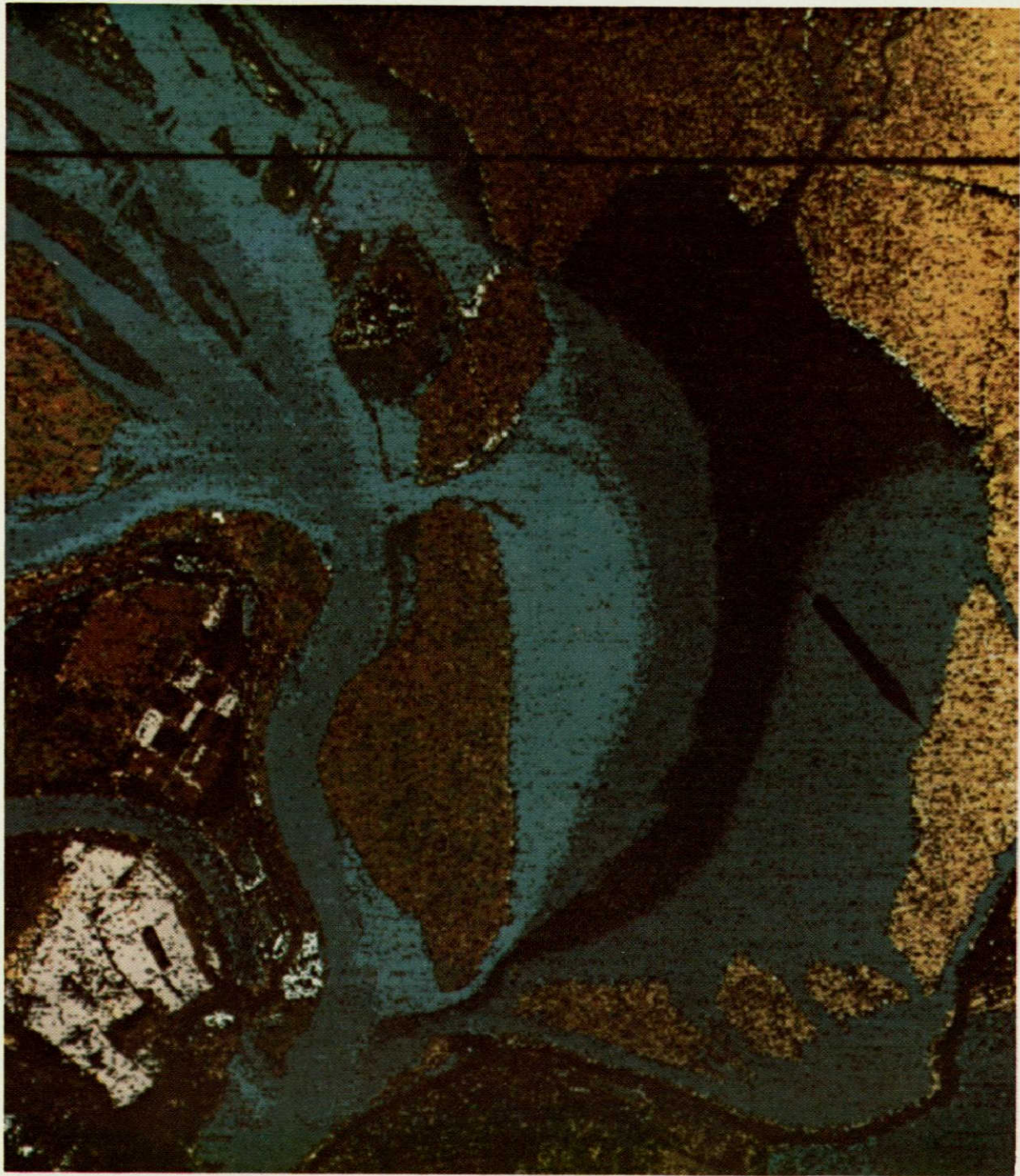

Figure 2.— Computer-derived classification map of aircraft multispectral scanner data.

REPRODUCIBILITY OF THE
ORIGINAL PAGE IS POOR

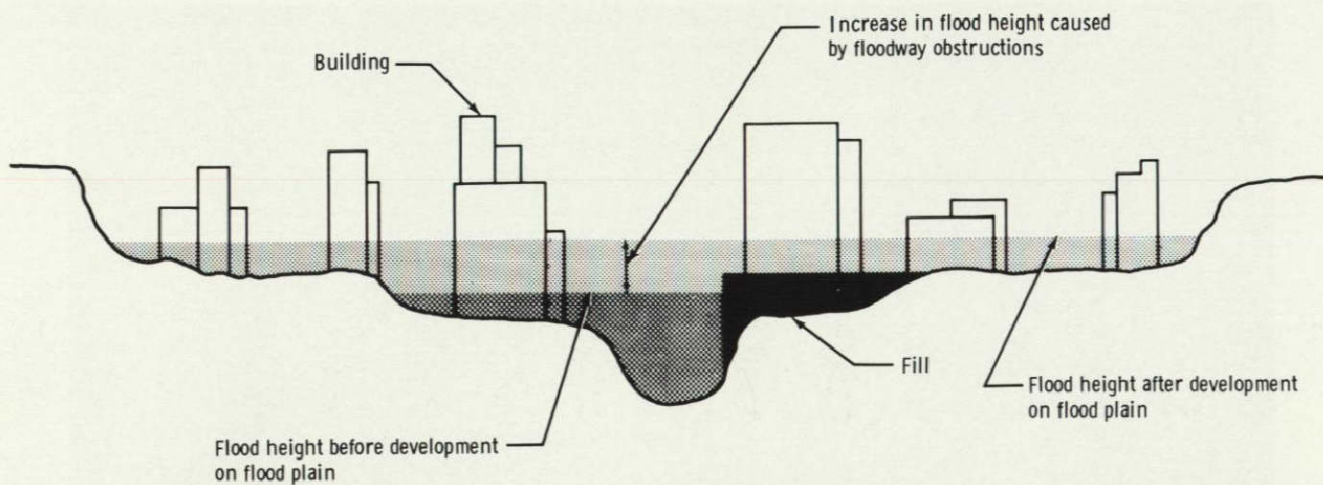

Figure 3.— Encroachment in a flood plain raises flood levels, which usually results in increased flood losses.

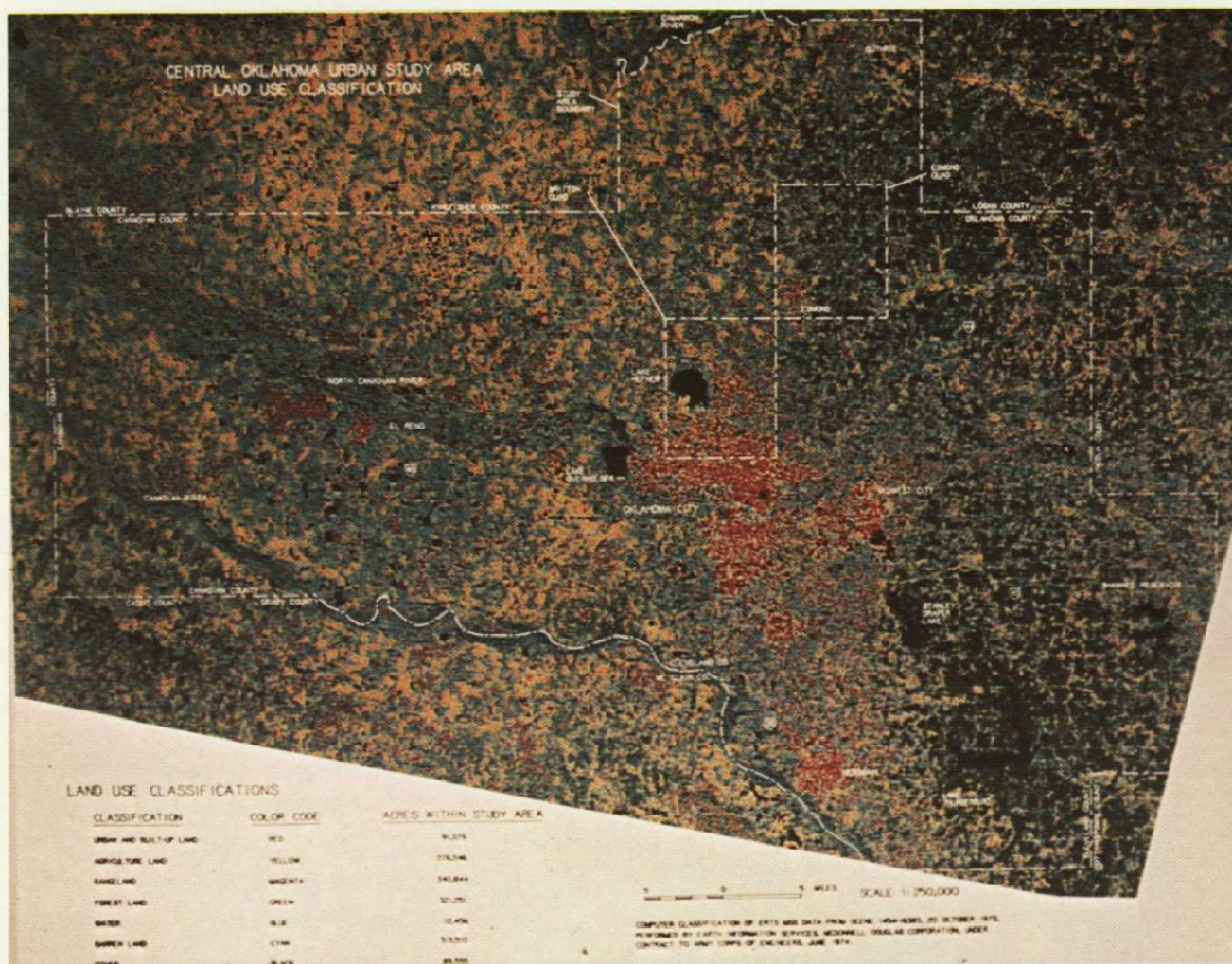

Figure 4.— Land use classifications by computer processing of Landsat multispectral scanner data.



Figure 5.— Shoal harbor entrance: Example of ineffective navigation structure.



Figure 6.— Coastal damage: result of sediment movement.

I have been talking about national problems, but regional problems are also important. One such problem is the aquatic growth in the waterways of the southeastern United States. Figure 7 shows the water



Figure 7.— Aquatic growth: Obstruction to waterways.

hyacinth infestation. These plants grow very rapidly with large, matted masses of submerged roots which prohibit navigation, primarily affecting recreational boats and small fishing craft. Sometimes these masses accumulate around bridges and other structures, causing structural damage.

The aquatic plant control program being conducted by the Corps has tended to approach this problem in an integrated system including mechanical, chemical, biological, and laser technology to hold back rampant growth of these obnoxious water weeds. This program has made progress in eliminating the problem weeds when they have entered major watercourses, but the ultimate solution depends on early detection of infestations in feeder streams. Remote sensing seems to be the answer. If we develop a technique for automatic classification of these obstructions, we can start attacking them before they become a serious problem.

CONCLUDING REMARKS

In summary, the Corps of Engineers is confident that remotely sensed imagery from satellite platforms will be used operationally. The technology is developed. Fine tuning, such as better definition of desired spectral ranges, improved resolution, and improved data handling, is needed. The last obstacle to overcome is getting the people who are going to be using these data to make decisions to define their requirements and learn to use the output of the sensors. The researchers have done their job, and now it is time for the users to go to work.

The Large Area Crop Inventory Experiment (LACIE)

I. THE USE OF LANDSAT DATA IN LACIE

R. B. MacDonald,^a F. G. Hall,^a and R. B. Erb^a

INTRODUCTION

A series of experimental investigations, using multispectral and meteorological data to identify and measure the areal extent of major crop types and to estimate their yields, has established a base of technology, which, if properly expanded, can satisfy the requirements of a major agricultural application objective, i.e., crop production inventories over large areas. The large area crop inventory experiment (LACIE) will expand on this available technology base and assemble an experimental system for demonstrating a crop production inventory done in a meaningful quasi-operational environment.

The experiment is supported by a parallel research, test, and evaluation (RT&E) effort designed to develop solutions in areas where additional technology may be required. The operation and evaluation of the experimental system will be iterated with the RT&E effort to develop a technology which either satisfies the applications objectives or demonstrates that the applications objectives can be satisfied, given that solutions can be developed for specific key problems.

Thus, the expected accomplishments of LACIE will be the development and testing of the technology to produce agricultural crop production inventories on a global scale or, alternatively, to define key problems to be solved prior to the implementation of an operational system.

This paper describes the background of events which shaped the LACIE design, the technical approach being pursued, the details of the implementation of this approach, and initial results of the experiment.

BACKGROUND

To appreciate the particular approach chosen from the many possible, the general context surrounding the design of LACIE must be understood. The major factors which influenced the design decisions were the applications, objectives, and requirements to be satisfied by the technology, the status of the existing remote-sensing technology; the time frame imposed to accomplish the stated objectives; the estimated available resources for the experiment; and the constraints, both self-imposed and indigenous to the agencies participating in LACIE. Each of these factors will be treated in the following sections.

Applications, Objectives, and Requirements

A general application objective shaping the overall LACIE design was to develop, test, and prove an economically important application of remote sensing from space. The crop inventory application was chosen because it represented an economically important application which could feasibly be accomplished near term with a system built from existing technology. Wheat was chosen as the crop for the experiment because of its importance in human nutrition and international trade.

This general definition of the objective was followed by more specific requirements. To prove out this technology, wheat production, area, and yield estimates would be necessary on a regional and national level. The system would have to be capable of producing periodic

^aNASA Lyndon B. Johnson Space Center, Houston, Texas.

PRECEDING PAGE BLANK NOT FILMED

reports containing wheat area, yield, and production estimates with a quantitative assessment of the confidence and accuracy of these estimates from planting through postharvest. In addition, the reports would have to identify the wheat growth stage at which the estimate was made and list all source data used to derive the estimate. The accuracy and/or timeliness of this information must improve upon the accuracy and/or timeliness already obtainable by the USDA from areas outside the United States and Canada. In addition, all information would need to be relatable to geographic coordinates. The experiment would have to be designed to produce experience and information helpful to the design of an eventual operational system. The system design itself was required to conform to existing USDA information security requirements and, where feasible, to existing standard specifications to facilitate technology transfer. Finally, the system would have to be designed to provide a basis for a potentially cost effective operational system.

Status of the Available Technology

At the outset of LACIE, a careful review and analysis of the status of the remote-sensing technology indicated that wheat production inventories for large areas were feasible. The major task facing LACIE was to expand the technology from the relatively local areas for which it had been developed and tested to the large areas over which it would be applied.

For area estimation, the major efforts would have to focus on the development of methodology to obtain training statistics for inaccessible locations and to extend these statistics over large regions; of equal importance, operations procedures would have to be developed to minimize the impact of cloud cover interference on Landsat data acquisition and to manage the analysis of the large volumes of data required for the large area application. Historically, a number of key developments contributed to the base technology. These developments are described in the remainder of this section.

In 1966, scientists coupled computerized pattern recognition analysis techniques with remotely sensed multispectral electromagnetic energy measurements to classify major agricultural crops automatically (ref. 1). It was learned that mature wheat could be accurately recognized in this way.

The first major application of this technology occurred during the corn blight watch experiment (ref. 2) in 1971. This experiment provided the first demonstration that a single agricultural crop could be

identified over large areas using computer-aided analysis of multispectral information. This feasibility demonstration was designed around a remote-sensing technology base developed during more than 6 years of research into the computer-aided analysis of multispectral data acquired from aircraft.

In addition, experiments were conducted from space with remote sensors on the Mercury, Gemini, and Apollo satellite systems during this period. A significant investigation conducted on Apollo 9 was the S065 experiment, which was a simulation of the future Landsat multispectral scanner (MSS). Photographs were acquired by an array of four cameras having film/filter combinations chosen to simulate the tentative spectral bands of Landsat. Scientists digitized these photographs, conducted computer processing, and demonstrated that agricultural crops could, in fact, be automatically recognized with Landsat-like measurements acquired from space (ref. 3).

In July 1972, the first Earth resources technology satellite, initially known as ERTS-1 and since renamed Landsat-1, was launched, and computer-aided analysis of multispectral data from a space platform commenced. The characteristics of the spacecraft-acquired MSS data as compared to aircraft-acquired data (narrower scan angles, near-simultaneous coverage over larger areas, and repetitive coverage) led to the simplification of many of the problems encountered with aircraft platforms and opened the way toward the development of a greatly expanded remote-sensing technology base.

A series of critical agricultural feasibility investigations using Landsat-1 MSS data acquired for a diverse set of test sites and environmental circumstances (refs. 4 to 8) generally established that major crops could be identified and measured with reasonable accuracy. The degree to which the feasibility had been established was somewhat limited, however, in that these investigations were of limited scope; i.e., results were obtained at a single time for a limited area, and were conducted against somewhat simple experimental designs which did not establish the performance indices needed to predict the performance associated with an areal inventory.

These early results were promising enough to convince some within the remote-sensing community that a technology base existed which could be expanded to conduct gross inventories of the areal extent of agricultural crops over larger areas.

A follow-on effort, the large area project, was proposed by the NASA Lyndon B. Johnson Space Center (JSC) in mid-1973, which would intensify the Landsat-1 feasibility effort and establish classification

accuracy and mensuration accuracy to identify major types of wheat grown in selected U.S. test sites. In parallel, the repeatability of the prior Landsat-1 investigations for selected row and small grain crops would be verified. At the same time, the USDA and Canada entered upon a joint study for spring wheat identification. In addition, a carefully controlled experiment was initiated at test sites in the United States to assess the capabilities of the most promising automatic data processing (ADP) techniques to identify several major food crops. This latter effort, known as the crop identification technology assessment for remote sensing (CITARS), is being concluded and will be documented in the future.

Concomitant to these events, interest was developing within USDA in having a more effective and timely method to inventory the available world food supply. Consequently, in the final quarter of 1973, personnel of NASA and the USDA began discussions to determine the most reasonable approach to the development and demonstration of a major application of available remote-sensing technology. It was agreed that the gross inventory of a single crop, wheat, would represent an application of considerable value. Wheat was chosen primarily because of the considerable experience which had been acquired in remotely sensing it (identification and area mensuration) and because of its importance as a crop. Wheat exceeds any other grain crop in the world in production and in areal extent. From a technical standpoint, the simplification offered by focusing on the identification and mensuration of a single crop was attractive. In this way, the major problem, i.e., expanding the technology to large area application, could be pursued with minimum distractions. Subsequently, based on the successful demonstration of this expanded technology, the focus could be shifted to solving problems related to multiple-crop applications.

The status of the technology in relation to the identification and mensuration of wheat was still somewhat uncertain, so preliminary feasibility investigations for wheat were conducted at the JSC and, as a part of CITARS, at the Environmental Research Institute of Michigan (ERIM). These investigations generally indicated that, in major wheat-producing regions, the identification performance characteristics for wheat were similar to other crop identification performances reported. However, there were indications of difficulties in inventorying marginal wheat-producing areas such as southern Indiana and Illinois.

The JSC investigation utilized Landsat-1 data acquired over Hill County, Montana, for three biological

phases of wheat (greening, heading, and mature) and from Burke County, North Dakota, for two biophases (emergence and jointing). These data were processed using only some of the algorithms to be used in LACIE and with much more analyst intervention than planned for LACIE. In addition, multiple Landsat passes were spatially registered and processed to evaluate the effect of multitemporal data on crop identification performance. The results of this investigation are shown in table I. The single-pass results were similar to those reported in a variety of other investigations. As can be seen, the use of multipass data provided a considerable improvement in performance. However, the relationship that these performance numbers would bear to the expected performance for an area inventory was not obvious.

The obscure relationship between the reported performance indices and the area estimation accuracy, which could be expected to result from an application of these techniques, was due primarily to three factors: (1) the relationship between the performance indices of the per pixel classifier and the area estimation accuracy was not completely established, and the majority of performance results reported were not in terms of areal estimation accuracy; (2) the degree to which the classifier performance would be degraded over larger areas by factors known to affect signatures (such as differences in atmospheric haze and Sun angle, soil color, growing seasons, and agricultural practice) was unknown; and (3) the error interactions between the areal estimation model to be used for LACIE and the per pixel maximum likelihood classifier to be used were unknown.

The latter two of these three factors would have to be answered by conducting an experiment over larger areas than had previously been examined and, thus, would have to be addressed by the experimental system in LACIE. The first of these was partially addressed, both empirically and theoretically, in early follow-on feasibility investigations for LACIE.

For the per pixel classifier to be used in LACIE, the estimate P_{ew} of the areal proportion of wheat in a sample would be the ratio of the number of pixels classified as wheat to the total number of pixels in the sample. Thus, in terms of the $P(w/w)$ and $P(w/o)$ in table I, P_{ew} for a sample, would be

$$P_{ew} = P(w/w)P_w + P(w/o)(1 - P_w) \quad (1)$$

TABLE I.— PROBABILITIES FOR CORRECT CLASSIFICATION AND PROBABILITIES FOR COMMISSION ERROR

(a) Hill County, Montana

Probability	Single pass			Multidate		
	t_1 (a)	t_2 (b)	t_3 (c)	(t_1, t_2)	(t_1, t_3)	(t_1, t_2, t_3)
$P(w/w)$	0.70	0.90	0.80	0.90	0.90	0.95
$P(w/o)$.20	.15	.05	.05	.05	.00

(b) Burke County, North Dakota

Probability	t_1 (d)	t_2 (e)	(t_1, t_2)
$P(w/w)$	0.75	0.85	0.90
$P(w/o)$.10	.10	.05

^aGreening.

^dEmergence.

^bHeading.

^eJointing.

^cMature.

where $P(w/w)$ is the probability with which wheat test pixels are classified as wheat; $P(w/o)$ is the probability for classifying nonwheat test pixels as wheat (commission error); and P_w is the actual proportion by area of wheat in the sample. Thus, the fractional difference D between the estimate P_{ew} and P_w would be related to $P(w/w)$, $P(w/o)$, and P_w by

$$D = \frac{P_{ew} - P_w}{P_w} = \frac{P(w/w)P_w - P(w/o)(1 - P_w) - P_w}{P_w} \quad (2)$$

This expression indicates the sources of the difficulties in relating the per pixel probabilities for error to the overall area estimation accuracy. The magnitudes of the terms $P(w/w)$ and $P(w/o)$ depend on the confusion crops present, which can vary considerably among regions planted to wheat. In turn, the fractional difference between the estimated and actual proportion, as can be seen from equation (2), depends on the relative amount of wheat present in the scene. The values of $P(w/w)$ and $P(w/o)$ reported in the literature, however, were for specific confusion crops with specific relative abundances, often unknown or unreported by the investigator.

For these reasons, a study was initiated within JSC to obtain preliminary estimates of D resulting from the per segment areal estimation scheme to be used for LACIE. For this study, three classification runs were made using

REPRODUCIBILITY OF THE ORIGINAL PAGE IS POOR

Landsat-1 data obtained over the Hill County, Montana (for a 2-by 6-statute-mile segment), test site. Two of the classifications were made using single Landsat passes acquired on April 16, 1973, and May 23, 1973, during the green and headed biophases, respectively. The third classification used 12 channels, a spatially registered combination of these 2 single passes, plus a pass acquired on June 27, 1973. For this segment within Hill County, the areal proportion of wheat P_w is 0.302 as determined from in situ observations. Table II gives the results of this study.

Notice that the values for $P(w/w)$ and $P(w/o)$ are somewhat worse than the values shown in table I for the earlier JSC studies conducted over the same site. These latter values were obtained using processing procedures more representative of the LACIE procedures, in that analyst intervention and iterations were greatly reduced. Even with these reported per pixel classification accuracies of from 58.6 percent to 85.1 percent, the proportion estimates for the segment were accurate to within 10 percent of the observed values, ranging from a maximum difference of 8.9 percent to as small as 1 percent.

These relatively small values of D result from the fact that, for these cases, the errors of omission $P(w/w) \cdot P_w$, which lead to underestimates of the amount of wheat, are largely balanced by the errors of commission $P(w/o) \cdot (1 - P_w)$, which lead to overestimates of the amount of wheat. If this error-canceling tendency could be maintained operationally for all LACIE segments processed, and D tended to fluctuate randomly about zero for these segments, then the classifier tested above would provide large area estimates with accuracies exceeding 90 percent.

For large area inventories, the root mean square error of the estimate given by equation (1) would also be important because, for a given sample unit, the total area estimation error would be given by

$$E = (b^2 + v^2)^{1/2} \quad (3)$$

where b is the average bias associated with the estimator and v is the variance component associated with the estimator.

Most investigations prior to LACIE had not been designed to quantify v , and it would be important to know the relative magnitudes of b and v in judging the capability of a particular classification scheme to satisfy a particular criterion for area estimation accuracy. A desirable classifier would be one leading to a small or known value for the bias. With such a classifier, the obtainable area estimation error E could then be decreased to an acceptable level by increasing the number of samples examined, or, if the bias were known, the estimate could be corrected. Without this property, the area estimate over a region would have a residual unknown error and its magnitude could not be reduced by increasing the amount of data processed.

The CITARS effort initiated prior to LACIE was designed to provide estimates of the performance parameters previously discussed. The results from this investigation indicate that some of the classification procedures tested do not have a negligible bias, and that there may be some difficulty in correcting the bias. However, certain other classification procedures,

TABLE II.— AREA ESTIMATION ACCURACY RESULTS
FOR HILL COUNTY STUDY

Parameter	Single pass		Multidate, three passes
	Greening	Heading	
$P(w/w)$	0.586	0.698	0.851
$P(w/o)$.141	.155	.060
Bias error D	-.089	.056	-.01

evaluated for performance on corn and soybeans at optimum times for discrimination of these crops, have associated values of bias and variance which would render them acceptable as area estimators of these crops. A test and evaluation effort similar to the CITARS investigations has been designed as an integral part of LACIE and will provide estimates of bias and variance specifically for wheat. Preliminary results of this effort will be presented later in this paper.

Since total production estimates are the desired end product of a crop inventory, investigations into available data and literature were begun to determine to what extent wheat yield (production per unit area) would need to be monitored and the status of the available technology for wheat yield estimation. An examination of the agricultural statistics reported by various countries indicated that yearly variations in reported yield accounted for as much of the yearly variation in reported production as did yearly variations in reported area. Thus, it would be necessary to monitor both area and yield if remote sensing were to provide production estimates which improved upon those estimates obtainable by existing methods.

An examination of the status of the available technology for wheat yield estimation indicated that the key technical issue to be faced in yield estimation was the development and testing of available yield models over regions important to world wheat production. This required a considerable effort, devoted to the development of the historic yield and meteorological data base required for yield model development. Factors not directly accounted for in the available models, such as fertilizer practice and catastrophic events (insects, disease, etc.), also had to be evaluated for their effect on the accuracy of predictions.

To establish the status of yield estimation technology, personnel from JSC conferred with investigators in the field and with personnel from NOAA who were already planning to monitor meteorological conditions for crop condition reports. Of the methods investigated for wheat yield determination, agrometeorological (agromet) models appeared to be the most promising approach for wheat yield estimation in a large-scale application. The application of multispectral sensing to determine crop condition was (and is) still in the early stages of development. The relationship between spectral data and yield had not been quantified, although multispectral imagery is considered to be one of several sources of information regarding crop condition. Agromet models existed which permitted yield estimates based upon measured values of key meteorological parameters. The feasibility of these

models for yield estimation was indicated by physiological studies which demonstrated that factors such as temperature and moisture played key roles in influencing wheat yield. In addition to these studies, statistical analyses in operational settings (such as described in refs. 9 to 12) verified the strength of these relationships. Values for the required meteorological variables could also be obtained on a near-real-time basis from ground stations, and the potential existed for supplementing these data with environmental satellite data.

From the investigations described above, it appeared that an experimental crop inventory system, utilizing remote-sensing technology, could be developed during a 2- to 3-year period. This system would demonstrate that remote sensing could be used to upgrade existing information-gathering capabilities and that the crop inventory application requirements could be satisfied, given the solutions to certain key problems.

Time Constraining Factors

The time frame and schedules imposed on LACIE resulted from several considerations. Of these, the following were major: the technical requirement of the remote-sensing community to maintain continuity in the development and use of satellite MSS data for practical applications; the time anticipated to extend the technology and develop an inventory system; and the particular timing for the wheat crop cycles over the LACIE regions of interest. Considering all this, a three-phased approach, spanning approximately 3½ years, was chosen. Phase 1 was twofold, concentrating on testing the capability of an area estimation system, built from existing technology, to determine wheat area within regions of the United States and to classify wheat in other areas; and development and testing of yield and production estimation models in regions of the United States. Phases 2 and 3 would test LACIE capabilities to determine wheat area, yield, and production in the United States and other wheat-producing regions.

Resource Availability

The three major determinants of resources required to execute LACIE were the design and construction of the experimental inventory system from available technology; the provision of people and computers to analyze the large volume of data required to support the application objectives; and the funding for the research,

testing, and evaluation required to fill gaps in the available technology.

The agencies involved placed a high priority on accomplishing the stated objectives of LACIE as soon as feasible, and resources were made available to pursue the LACIE objectives vigorously with a goal of delivering, at the culmination of LACIE, proven technology and a definition of the key problems to be solved prior to the implementation of an operational inventory system.

Other Constraining Factors

The last items in the consideration of the LACIE design were self-imposed constraints and certain organizational and institutional factors peculiar to the agencies participating in LACIE. Certain constraints were self-imposed by the project designers to simulate the structure of the anticipated operational situation. The two most important constraints arising from this philosophy were (1) that the use of in situ acquired ground observations for the current year would be restricted and (2) that the experiment would be conducted in a quasi-operational manner with analysis done in real time (14 days from data acquisition to completion of processing) with reporting geared to current crop reporting schedules.

Constraint (1) restricted the acquisition of in situ crop type identifications to limited areas in the United States, and further limited the use of these data to the evaluation of LACIE and to the development of classifier training statistics for regions outside the United States. This restriction required that two new elements of technology be developed. These elements were analyst procedures for manual analysis of Landsat imagery for crop type identification for a small fraction (2 percent) of the data and signature extension procedures for extension of the spectral signatures to the remaining 98 percent of the Landsat data.

Because the LACIE effort required a joint application of NASA, USDA, and NOAA resources, constraints were imposed upon the LACIE design which reflected the existing programs, capabilities, facilities, policies, and goals of each agency.

The design of LACIE was shaped in a major way by the nature of the existing implementation for ADP analysis of multispectral data in NASA, and the extent to which this implementation could be modified or augmented given the projected resources and schedule. The Earth resources interactive processing system (ERIPS) contained a majority of the implemented data processing technology readily available to LACIE. The

ERIPS was resident on IBM 360/75 machines in the Houston Real Time Computer Complex (Mission Control Center). To meet the schedules imposed upon LACIE, a decision was made to develop the LACIE experimental system around ERIPS, changing or augmenting it only where necessary. The influence of this decision is strongly reflected in the current LACIE subsystem for processing Landsat data to provide area estimations.

Another set of factors which strongly influenced the LACIE design was the decision to use multitemporal data, the associated state of the art in registration technology, and the projected available resources for registering the LACIE MSS data. A reasonable upper limit on registration accuracy required for multitemporal recognition processing was estimated at one pixel root mean square. The registration technology which could readily be implemented for use by LACIE would permit a one-job registration (to the required accuracy) of roughly one-hundredth of a Landsat frame, or less than about a 10- by 10-statute-mile square on the ground. The number of one-job registrations possible with the projected available resources precluded an optimally efficient sampling strategy with units of smaller size scattered throughout each Landsat frame; that is, the quantity of 10- by 10-statute-mile portions required to cover the geographic area under consideration could not be registered within the projected available resources. Within these constraints, a sample unit of 5 by 6 nautical miles was chosen as adequate.

The major factors within the USDA which influenced the design of LACIE were the level of resources available to acquire the ground observations and measurements required to support critical development and evaluation tasks within LACIE, and the desire of USDA to facilitate the transferability of technology validated by LACIE from NASA to USDA. The USDA projected sufficient resources to obtain observations and measurements within approximately 28 intensive test sites totaling approximately 286 000 acres. In addition, the data published in USDA crop reports would be available. Although the resources are considerable to obtain even this amount of ground data, much ingenuity was required to develop an experimental design which could use this data set to properly evaluate new developments and to quantify the performance of the experimental system.

In early 1974, project planning and certain key developments were begun to initiate the large area crop inventory experiment. The year was spent developing the management approach, designing the experiment, designing and building the system to support the

experiment, and working out the necessary interagency agreements for joint USDA, NOAA, and NASA participation. This work culminated in late 1974 in a joint project plan, which was reviewed by persons representing the leading technical expertise within the remote-sensing community. In November 1974, initial operations began with a preliminary data system for classification and mensuration of wheat using Landsat-1 data acquired from selected segments in Kansas.

DESCRIPTION OF THE LACIE

The description of LACIE will be treated in two parts. The first section will describe the technical approach, i.e., the basic design of the experiment, including the approach to area, yield, and production estimation; the experimental data system design; the flow of the data through the system; the evaluation of the system output products; and details of the research, test, and evaluation effort supporting LACIE. The second section will describe the functional approach, i.e., the functions required to support the development, test, operation, and evaluation of the LACIE data system; the organization developed to execute these functions; and the phases and schedules for implementing the basic approach.

Technical Approach

The crop identification and mensuration is carried out with Landsat multispectral scanner (MSS) data, and the inventory is being performed on a sampling, rather than an exhaustive coverage, basis. Data are being acquired through the normal NASA Goddard Space Flight Center (GSFC) processes over the geographic areas under study.

A stratified random sampling strategy has been developed employing 5- by 6-nautical-mile segments, randomly allocated to strata according to the 1969 agricultural census data specifying areas planted to wheat in the United States. A total of 637 sample segments was allocated to the United States to obtain a sample error of approximately 2 percent. This criterion is, to some degree, arbitrary because the precision and accuracy of the production estimates are the final concern in accuracy. However, at this stage of development, not enough is known regarding the overall error interactions between the LACIE system components to design a sample strategy against a specific set of performance criteria. Preliminary analysis of the

U.S. strategy indicates that the associated sample error (precision) is less than 2 percent at a 2σ confidence level. As will be discussed later, a preliminary performance assessment of LACIE area estimates in Kansas gives no reason to alter the sample strategy design. In the RT&E effort, alternate sample strategies are being investigated to minimize the cloud cover interference problems.

The LACIE sample strategy for the United States allocates 637 segments to counties, such that each county receives sample units in proportion to the product of the total area of the county times the estimate of the standard deviation of wheat areal density in the county. The estimate of the standard deviation is derived from the 1969 agricultural census estimate of the wheat areal density for the county by assuming the wheat density to be binomially distributed within the county. This strategy usually gives from 0 to 5 segments to a county, and for each stratum (crop reporting district (CRD) for the United States), a maximum of about 15. Figure 1 is a facsimile of segment locations within a CRD. Area estimates for counties receiving no segments will be ratio estimates to counties which do contain segments. Data for these 5- by 6-nautical-mile segments (containing 117 lines of 196 pixels each) will be extracted from the full scenes by GSFC and transmitted to JSC.

Roughly 20 percent of the segments will be training segments. In the Landsat imagery acquired from these segments, training fields will be manually located to train the classification algorithm to identify wheat in both the training and ordinary segments. An ordinary segment is one for which no training fields are selected. Training segment data are acquired at every opportunity to maximize the probability of acquiring acceptable data. Acceptable is defined at GSFC in terms of minimally tolerable interference from cloud cover (less than 30 percent of segment area obscured).

The GSFC will similarly preprocess ordinary segments which will be transmitted only four times during the growing season, once for each of the following biological phases: crop establishment, green, heading, and mature. The first data taken in each phase which meet quality criteria will be used. For each segment, the first take of the season will become a reference set, and subsequent data takes will be registered to the reference set to form a multitemporal set of up to 16 channels.

The analysis of the MSS data is being intentionally carried out without the use of current ground data. Ground observations will, of course, be used for evaluation purposes, but the only data used operationally will be data typically available in real time over large areas from existing sources. This self-imposed

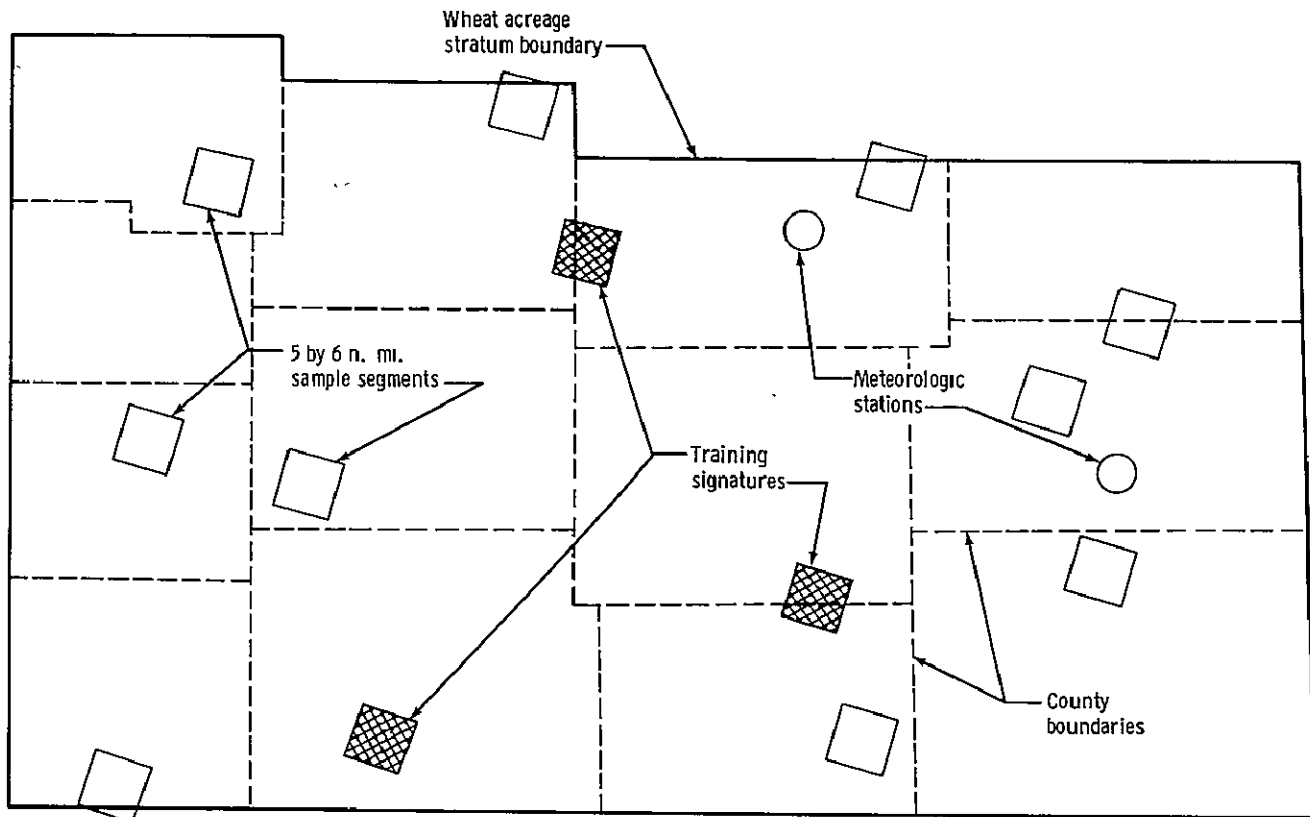

Figure 1.— Segment locations within a crop reporting district.

constraint makes it necessary to train the classifier using Landsat data with crop calendar information. To enhance the chances for success, seasonally adjusted crop calendars, developed from normal year calendars modulated by current year weather data, are being used.

The initial crop calendar update model implemented for LACIE (operated at Washington by NOAA) is based on the Robertson biotime model (ref. 13). This model, based on real-time measurements of maximum and minimum daily temperature and USDA estimates of planting start dates, will be used to provide biweekly updated estimates of the actual times for occurrence of the LACIE biophases for each of 60 crop reporting districts in the United States. In addition to use in training field identifications, the outputs of this model will be used to specify Landsat data acquisition windows to GSFC for each LACIE biophase.

Following receipt in Houston, Landsat digital data are converted to film image form, and analyst interpreters select, from training segments, 40 to 50 training fields for wheat and other agricultural categories and provide a definition of the boundary of such fields to the ADP analyst for the classification. This represents manual analysis of about 2 percent of all Landsat data acquired.

In these segments, the analyst interpreter (AI) will rely mainly on interpretive keys, which distinguish wheat from nonwheat based on tonal appearance and change during the growing season, and spatial information such as texture and shape. In addition, the AI will be provided with historical cropping practice data for each segment. In regions where wheat has a crop calendar distinctly different from other crops, the AI should be able to accurately distinguish wheat from nonwheat, provided he has an accurate knowledge of the current year's cropping calendars for the various crops.

Each week, the AI will be provided with weather summary data (prepared by NOAA) summarizing meteorological events known to affect crop appearance. Snowfall, heavy precipitation or drought, and temperature extremes will be the key variables of interest. While the AI procedures previously described will be the basis of the initial LACIE effort, the concept of extending signatures between regions analogous to each other is being investigated in the RT&E activity.

Image analysis will also be used for another purpose. Previously, difficulty has been experienced in accurately classifying such noncropland areas as forests and towns. Frequently, such areas are highly heterogeneous at the

Landsat resolution, and poor classification has resulted. Therefore, major noncropland areas will be identified by image analysis and will be manually excluded. Similarly, areas in which data quality is poor, as a result of such factors as clouds and noise, can be identified and manually excluded.

Major wheat-growing regions will be partitioned into smaller areas over which signature extension is expected to be successful. This partitioning will be accomplished based upon such ancillary data as crop calendars, meteorology, and soil color, as well as on the basis of trial classifications. Each signature extension region will contain one or more training segments. If cloud cover or other operational problems prevent acquisition of the training segment for a given signature extension region, signature extension will be attempted from a neighboring region. This neighbor region approach is expected to provide reduced classification accuracies in the region without a training segment. It is anticipated that signature extension regions will be typically about the size of a Landsat scene.

The classification subsystem design is based upon the judgment that wheat can be separated adequately from other crops by analysis of up to four acquisitions of Landsat data during the biological development of wheat. The biophases chosen are crop establishment: planting to booting (with a gap during dormancy for winter wheat); green: booting to heading; heading: heading to soft dough; and mature: soft dough to harvest.

Signatures obtained on one calendar date within a biophase are not necessarily expected to be valid for other acquisition dates within the same phase; however, training field boundaries generated for one date will usually be valid on other acquisition dates within the same biophase. Therefore, by acquiring the training segments on each Landsat pass and using training field boundaries located on one acquisition date for that biophase, statistics appropriate to a different acquisition date can be computed without expending additional image analysis effort. Plans are to conduct major image analyses only upon training segments and only once per biophase.

Procedures for the classification were based in part on the CITARS procedures described in the background. Basically, the training data are clustered to aid in selecting suitable training classes. Sun angle and mean level adjustments are made if required. A feature selection process can be employed to reduce the number of channels using the Bhattacharyya distance as a separability measure. The segment is classified with a maximum likelihood classifier into wheat and nonwheat.

A high degree of analyst interaction will be possible, but the intent of the system is eventually to automate the classification as completely as possible. The fraction of each segment area classified as wheat will be determined by ratioing wheat pixel count to total pixel count.

The key RT&E issues being addressed in the classification of Landsat data are methods for developing training signatures, methods for extending the developed signatures over large areas, and improved methods for estimating wheat proportions within the sample segments.

The technology required for LACIE represents, to some extent, a departure from the existing technology base in that in situ ground observations have been traditionally used to train the classifier. The LACIE RT&E effort, in this regard, is focused on improving analyst interpreter techniques and the development of the analog area concept discussed earlier.

Signature extension is key to LACIE in that the manpower expended per segment decreases drastically with increasing ability to apply training statistics over larger areas. Signature extension RT&E is focused on definition of methods to determine signature strata, i.e., geographic regions for which multispectral signatures are sufficiently homogeneous so as not to significantly degrade classification performance; and development of algorithms which permit signature extension between areas with different environmental conditions, i.e., atmospheric conditions or Sun angles. Signature strata will probably be uniform in soil spectral characteristics, crop biophase, and the agricultural practices employed.

Improved proportion estimation schemes are key to developing unbiased estimations of wheat proportions within segments. The importance of this is pointed out in the background section of this paper.

Yield projections will be made from models which involve weather data, typically, precipitation and temperature. Such data will be obtained from current (ground) networks. The development of the yield models is being carried out by NOAA at its Center for Climatic and Environmental Assessment at Columbia, Missouri. The initial models (which will be statistical in nature, i.e., expressions for yield as a function of key meteorological parameters) will be derived from regression analyses using historical yield and weather data for each of a number of yield strata. For the United States, in phase 1, a stratum will be a crop reporting district. Within any one stratum, the same set of coefficients in the model will apply; however, varying weather conditions at various locations within the stratum will result in different projected yields. The operation of this model will take place at NOAA

facilities in Washington, D.C., and the results will be supplied to JSC. Basic meteorological parameters, currently available on the World Meteorological Organization (WMO) network, will provide the input data to the models.

The later phases of LACIE may employ yield models of a more sophisticated type, such as the Baier model, in which plant growth phenomena are taken into account explicitly. Also, observations from environmental satellites may be used to extend and interpolate the meteorological data from the WMO network.

The area and yield determinations per stratum provide the basic input to a production estimate. The LACIE system will produce monthly yield estimates, area estimates, and production estimates for each major wheat-producing crop reporting district, state, and region in the United States.

For each crop reporting district, the area estimate will be computed by the relationship

$$A_j = A_{1j} + A_{2j} + A_{3j} \quad (4)$$

where A_{1j} is the estimate of the area in the counties within the j th CRD which had no segments allocated; A_{2j} is the estimate for those counties which were allocated fractions of segments PPS (probability proportional to size without replacement); and A_{3j} is the estimate for counties allocated one or more segments.

For counties falling into the first class, the area estimate is

$$A_{1j} = (A_{2j} + A_{3j}) \frac{x_j}{w_j} \quad (5)$$

where x_j is the agricultural census wheat area for counties in group 1, and w_j is the agricultural census area for the CRD.

For counties with total area A_2 falling into class 2 containing m_j sample segments,

$$A_{2j} = A_2 \frac{p_j}{m_j} \sum_{k=1}^{m_j} \frac{\hat{p}_{jk}}{p_{jk}} \quad (6)$$

where \hat{p}_{jk} is the LACIE wheat proportion estimate within the k th county; p_{jk} is the agricultural census wheat proportion estimate in that county; and p_j is the census estimate for the j th CRD.

For the m_j counties falling into class 3, A_{3j} is simply the product of the average areal proportion of wheat in each county as estimated from the sample segments multiplied by the area of the counties containing the segments, i.e.,

$$A_{3j} = \frac{A_3}{m_j} \sum_{k=1}^{m_j} \hat{p}_k \quad (7)$$

where \hat{p}_k is the wheat areal proportion in the k th county.

Methods for wheat yield aggregation are still being investigated as a part of the LACIE research, test, and evaluation effort, as is production aggregation.

The final step in each phase of LACIE is an evaluation of the output products of the LACIE system. This evaluation begins with an assessment of the accuracy of the output estimates of area, yield, and production. These accuracy figures are included with the area, yield, and production estimates and transmitted in a report to an information evaluation (IE) group within the USDA in Washington. The IE group will compare the LACIE estimates to conventional estimates and note differences in these. In addition, the LACIE reports will be assessed for their value to the normal operations of USDA. The IE group will provide feedback to LACIE personnel in Houston. Any discrepancies between the LACIE estimates and conventional estimates will be investigated by USDA analysts at Houston to determine if differences are due to faults in the LACIE approach (data, techniques, etc.).

For area accuracy, three main quantifiers are proposed: (1) the percent difference between conventional estimates and the LACIE estimates (i.e., percent bias); (2) the precision of the area estimate $P = [Var(\hat{p})]^{1/2}/\hat{p}$ where \hat{p} is the LACIE wheat areal density estimate for a given strata, region, or country; and (3) the confidence level α that the LACIE estimate \hat{A} is within 10 percent of the conventional estimate A .

For a large area, such quantifiers are more easily defined than obtained. In the United States, the only information available for comparison to the LACIE

estimates are crop identification data obtained by the USDA from the 28 intensive test sites, ranging from 5 by 6 nautical miles to 3 by 3 nautical miles in extent, and located in major wheat growing regions; the USDA Statistical Reporting Service (SRS) estimates of area at the county, crop reporting district, state, regional, and national level; historic area data compiled by the SRS at these levels; and in situ information from the SRS sample segments (approximately 1 nautical mile square).

If, as was the case in LACIE development testing, retrospective data for prior crop years are being analyzed, the accuracy of the LACIE estimates may be assessed by comparing them to the SRS data. It is generally believed that although the SRS data are not 100 percent accurate, their accuracy is sufficient to use as a standard against which to evaluate how well the LACIE accuracy is meeting its goals.

Real-time estimates of the percent bias of the LACIE estimates will need to be inferentially determined without reference to the SRS data because those data will not be available to the LACIE system. Methods are being developed within LACIE which will use intensive test site and other data.

The precision of the LACIE estimates can be determined from an examination of real-time LACIE area estimates and historic SRS area data. The variance of p , $Var(p)$, is given for an area composed of K strata by:

$$Var(p) = \sum_{k=1}^K C_k^2 Var(p_k) \quad (8)$$

where $Var(p_k)$ is the variance of the estimate of the wheat areal proportion in the k th stratum, and C_k^2 are areal density weighting functions for the strata within the area. Within a given stratum (assuming all counties are class 3 counties in the particular example), $Var(p_k)$ is given by:

$$Var(p_k) = \sum_{j=1} D_{kj}^2 Var(\hat{p}_{kj}) \quad (9)$$

where $Var(\hat{p}_{kj})$ is the variance of the estimate of the wheat areal proportion contained in the j th county within the k th crop reporting district, and D_{kj}^2 are areal density weighting functions for the counties.

Estimating the variance $Var(p_{kj})$ is not straightforward in LACIE since many counties contain only one sample segment. A good estimate of this quantity is critical since it will determine to what degree the accuracy of the LACIE estimates can be determined. The figures quoted previously for the sample error associated with the LACIE sample strategy were based on the assumption that the wheat proportion distribution relative to the 5- by 6-nautical-mile sample segment would be binomial, so that $Var(p_{kj}) = p_{kj}(1 - p_{kj})$. This estimate will be somewhat conservative (i.e., will create overestimates of the precision) because LACIE sample segments will be considerably larger than the average wheat field, and the wheat fields tend to be distributed somewhat uniformly throughout a county, as opposed to being conglomerated in just one portion of the county.

Latest estimates of the variance of the LACIE area estimates are based on the use of historic area data and real-time LACIE proportion estimates to determine the within-county variance. For a stratum, historic SRS area figures are used to determine the between-county variance of p within the stratum. This figure is subtracted from the estimate of the variance of the LACIE proportion estimates over the stratum to obtain an estimate of the LACIE within-county variance. Other methods to estimate this variance are being investigated in the RT&E effort.

Given an estimate of the bias and precision, an estimate of the confidence level can be obtained. For LACIE, α will be defined for a stratum, state, etc., as

$$\alpha = P(|\hat{A} - A| < 0.1A) \quad (10)$$

where \hat{A} is the LACIE estimate of the area, and A is the conventional SRS estimate.

As a performance objective of the LACIE experimental system, an α of 0.9 at a national level has been chosen. Such a choice requires that the LACIE area estimate be, with a 90-percent confidence, within 10 percent of the conventional estimate. This criterion has been referred to as the 90/90 criterion.

By assuming the LACIE estimate is normally distributed about its mean value, the estimate of the bias and the $Var(p)$ can be used to determine α .

Methods for similarly quantifying the performance of the yield and production estimates are being developed in the RT&E effort. The focus in this area is to develop an error simulation/propagation model which describes

the contribution of yield and area errors to the production estimation error.

Implementation Approach

To understand the implementation approach taken for LACIE, it must be realized that the experiment calls for simultaneous execution of activities which, given a more leisurely schedule, would normally be undertaken sequentially. Specifically, the application of the base technology had to proceed in full recognition of the fact that many components of this application evaluation system (AES) had not been fully developed and thoroughly tested. Simultaneously, research, test, and evaluation had to proceed to strengthen the suspect areas and to conduct thorough tests of new system components prior to their introduction into the mainstream AES. The way these project elements relate is depicted graphically in figure 2. As this figure makes clear, the role of LACIE is, for one important agricultural application, to bridge the gap between the multitude of feasibility tests and exploratory studies and the eventual operational systems.

The functional organization for LACIE involves numerous elements of the three participating agencies. Each agency maintains its own administrative control over those resources allocated to LACIE. However, at the project level, the technical staff is fully integrated (fig. 3).

A number of implementing organizations may be in collaboration for a particular subsystem. For example, in

the case of the data acquisition, preprocessing, and transmission subsystem (DAPTS), NASA Goddard, USDA field staff (Agricultural Stabilization and Conservation Service), and NOAA (Environmental Data Service, National Weather Service, and National Environmental Satellite Service) all acquire and preprocess portions of the data for LACIE in response to requirements specified by the subsystem manager.

In other cases, a single implementing organization, such as the NASA Data Systems and Analysis Directorate, will implement hardware and software that support the functional requirements of several subsystems. For example, the portion of the LACIE data system which was derived from the ERIPS, referred to earlier, supports the functional requirements of the electronic part of the information storage, retrieval, and reformatting subsystem (ISRRS) and the classification and mensuration subsystem (CAMS).

Whenever possible, the personnel assigned to LACIE have no other duties. In each case, the responsibility for a particular area is made in consonance with the respective agency roles. For example, the crop assessment subsystem (CAS) manager is from USDA, and the yield estimate subsystem (YES) manager is from NOAA. When possible, personnel from USDA are assigned to each functional area because USDA will eventually wish to operate an operational follow-on system; NOAA participation is limited (by resource availability) to YES, DAPTS, and project management activity.

The great majority of LACIE effort and resources is allocated to the AES. This system provides the actual

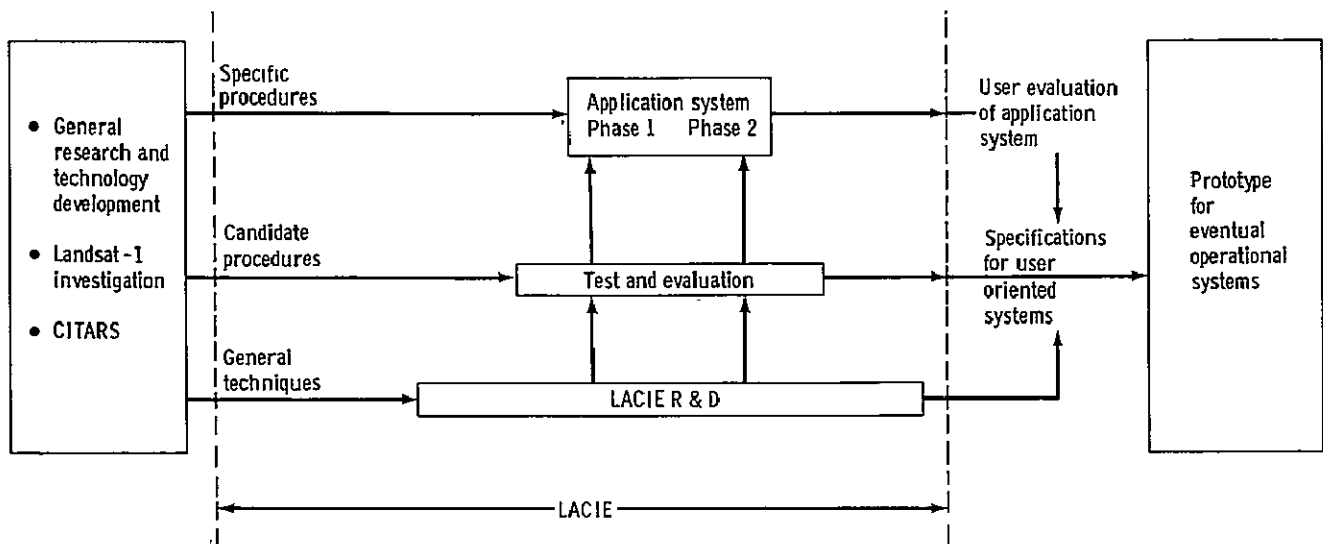

Figure 2.- LACIE project elements.

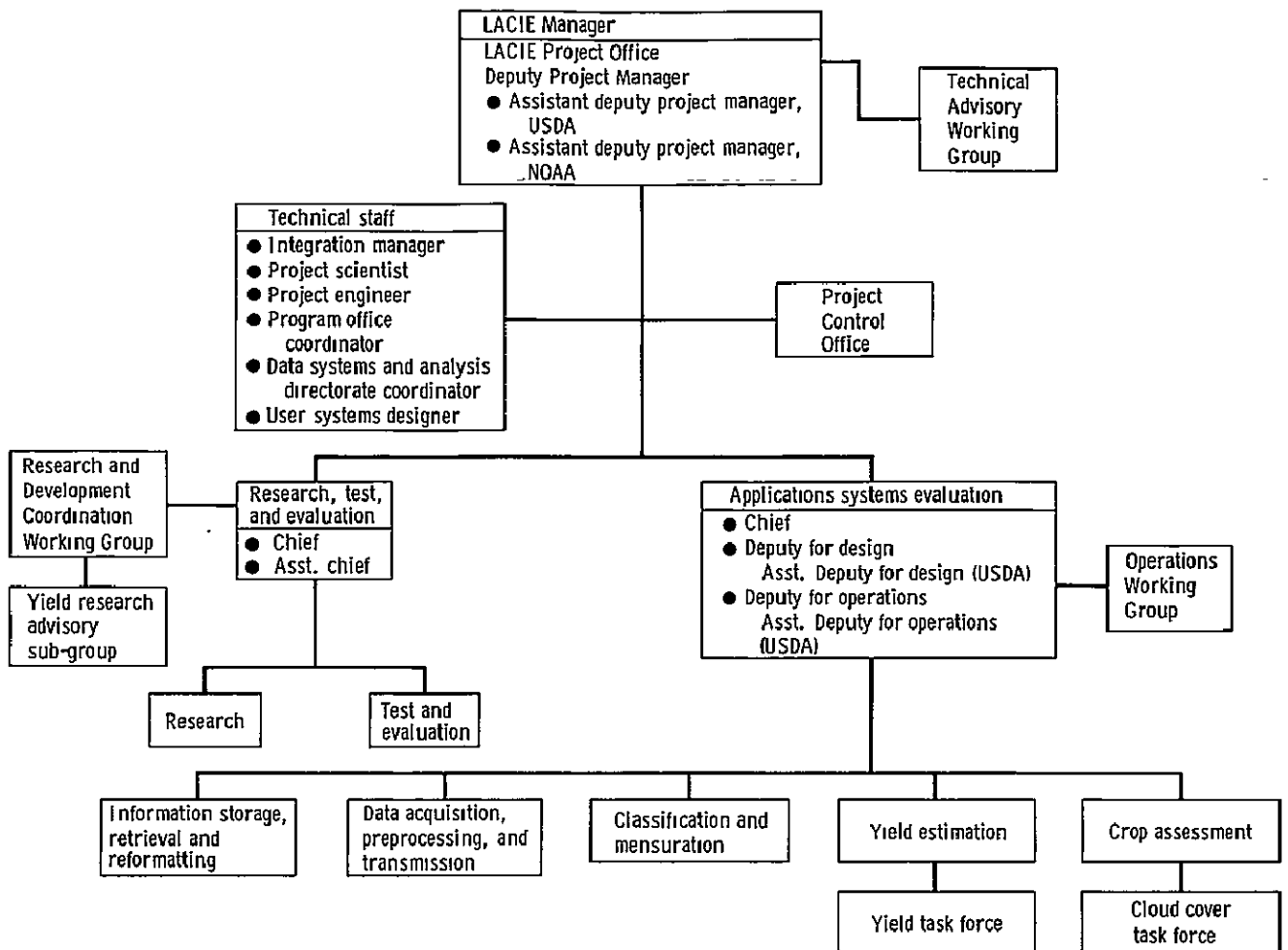

Figure 3.— LACIE project organization.

mechanisms, including ADP equipment, software, personnel, procedures, and facilities, with which LACIE data are processed to produce wheat inventory reports and user evaluations of the usefulness of those reports. A simplified schematic of the AES is given in figure 4. A full treatment of the functioning of this system is beyond the scope of this paper. It should be noted, however, that a system as complex as the AES requires the exercise of careful control over requirements, configuration, and operation. The implementation of the system is, accordingly, carried out in response to formally documented detailed requirements. Interfaces between collaborating organizations are rigorously defined by interface control documentation (ICD), and formal change control procedures are in force to eliminate uncoordinated change. The research, test, and evaluation effort, although modest in comparison with the AES effort, is fully as important in reaching the

overall goal of a successful application of remote-sensing technology.

Research of a highly focused and applied nature is initiated pursuant to requirements developed by the AES personnel who perceive the technological gaps, in conjunction with research personnel who are in touch with the most current developments in the remote-sensing community. This research is carried on under contract by academic and research institutions long experienced in the field. A tabulation of the major task areas and the institutions working on each is given in table III. In each case, a task team monitors the contract and ensures its congruity with LACIE needs. Both research and AES personnel participate.

In each research effort, specific goals are spelled out with deliverable products scheduled at appropriate times. Generally, such a product would be an alternate algorithm or procedure for some part of the LACIE

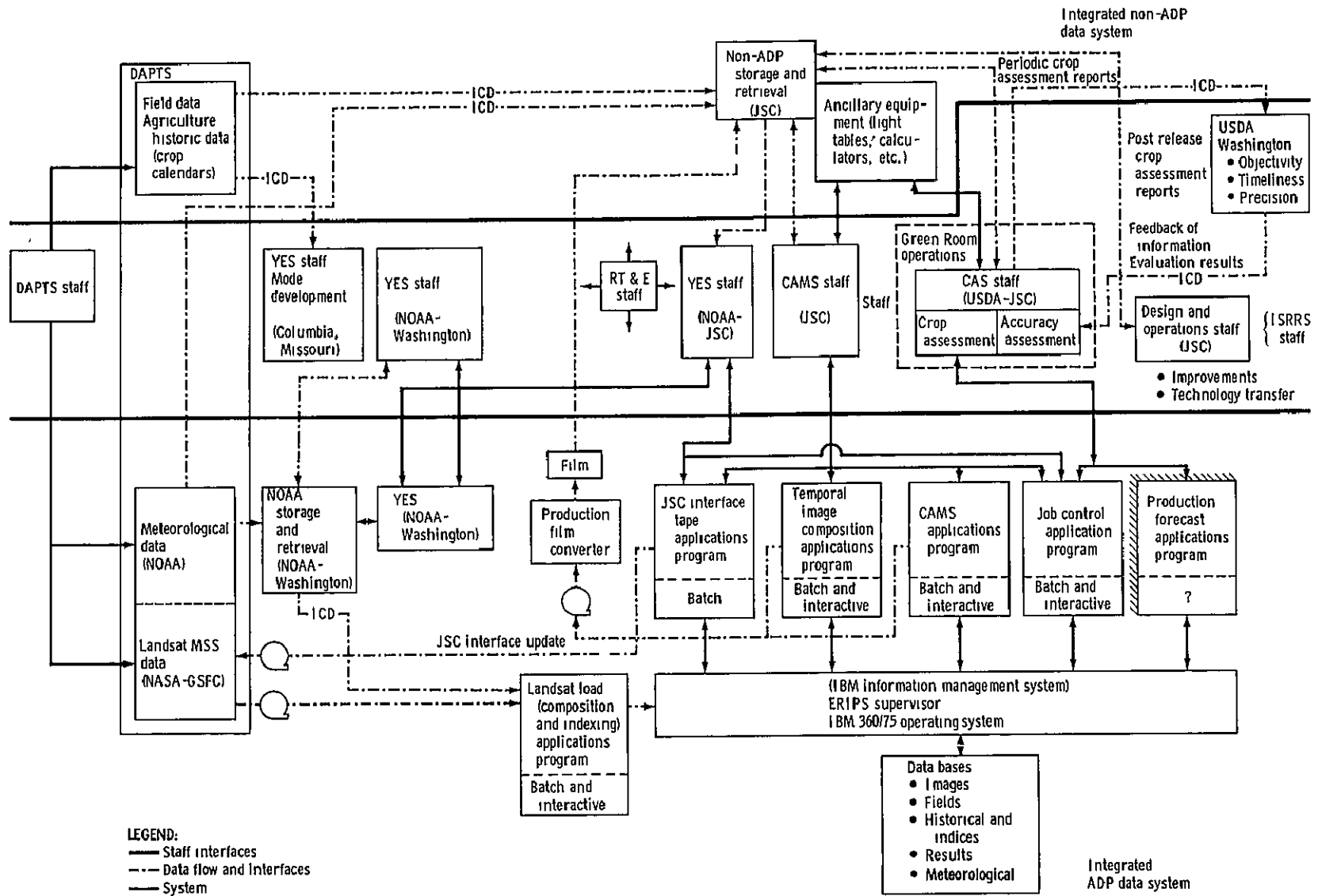

Figure 4.— LACIE integrated applications evaluation system.

TABLE III.— MAJOR TASKS IN LACIE
RESEARCH, TEST, AND EVALUATION TOGETHER
WITH PERFORMING ORGANIZATIONS

Task	Performer
Area	
Definition of training statistics	Univ of California at Berkeley (UCB) Laboratory for Applications of Remote Sensing (LARS) ERIM
Registration	LARS
Classification Temporal sampling strategy Multitemporal classification Proportion estimation	Texas A. & M. Univ. (TAMU) Univ. of Texas at Dallas (UTD) ERIM UTD TAMU Rice Univ Univ of Houston TAMU
Feature selection	UCB LARS ERIM Colorado State Univ
Signature extension	UCB LARS ERIM Colorado State Univ
Estimation of unharvested wheat	TAMU
Sampling and aggregation	UCB TAMU
Field measurements ^a	LARS TAMU JSC Earth Resources Laboratory JSC Flight Operations Directorate
Yield	
Yield models	Kansas State Univ. TAMU ERIM Clemson Univ.
Production	
Error model	TRW, Inc

^aSupports classification, signature extension estimation of unharvested wheat.

system. During the development of such a product, some testing will, of course, have been done. If the results appear promising, further, more rigorous testing will be done either by the developing institution according to an approved test plan or by the test and evaluation personnel in the project. Implementation of the new procedure in the AES will take place in parallel with the testing or following it, depending upon the urgency of incorporating the new procedure and implementation

resources available. It should also be noted that RT&E effort can contribute in an important way to eventual follow-on systems by providing solutions for key problems that may be identified, but not resolved, during the lifetime of LACIE.

The development of the LACIE system and its operation is being conducted in three phases, each tied to the wheat-growing cycle and expanding in scope as capability increases. The first phase covers the 1974-75 crop year (in the United States) and addresses area estimates for nine wheat-growing states in the Great Plains. In smaller areas, i.e., one or two states, yield models will be tested and production estimates made. Classification tests will be conducted on representative segments in other wheat-growing regions, and the 28 intensive test sites in North America will be analyzed to provide one basis for performance assessment.

The second phase, from the fall of 1975 to the spring of 1977, will include area, yield, and production estimates for a large area, likely the entire United States, a continuation of tests on representative sites elsewhere and intensive test sites, and will cover a longer crop cycle to include both Northern and Southern Hemisphere wheat crops.

The third phase, from the fall of 1976 to the spring of 1978, will provide area, yield, and production estimates for one or more large area regions and will incorporate those refinements to the technology developed during the RT&E efforts of the earlier phases.

The schedule for LACIE is clearly very success-oriented. This was considered necessary, however, to fully exploit the Landsat-2 capability and to demonstrate a large-scale application of space remote sensing at the earliest possible time.

SUMMARY OF INITIAL PERFORMANCE ASSESSMENT

At the writing of this paper, an initial assessment of the performance of the initial LACIE/CAMS system had been made by conducting analyses of the results of processing Landsat-1 data acquired during 1973 and 1974 on 33 segments in Kansas. For this study, the LACIE sample segments were moved within each county to encompass either an intensive test site or an SRS sample unit. Of these 33 segments, 5 were LACIE intensive test site segments for which "wall to wall" in situ observations of crop type were available, and the remaining 28 each contained a 1- by 1-statute-mile segment (a section) of crops observed for crop types by the Statistical Reporting Service of USDA.

For three of the five intensive test site segments, Landsat data were available for all biological phases. For the other two, cloud cover resulted in the data for two biological phases not being acquired. For this 1973-74 data set, biophase 4 is postharvest. For the 28 remaining segments, 22 were acquired during biophase 1; 4, during biophase 2; and 2, during biophase 3.

The analyst interpreters' performance was evaluated on the intensive test sites by comparing their identifications of wheat and nonwheat to ground observations. The AI's picked approximately 15 wheat and 15 nonwheat fields for classifier training. The figures in table IV are percent correct identifications of these fields when compared to the ground observed identifications.

The classification performance for wheat obtained by using the analyst-interpreter-provided fields as training data was determined. The classification performance varied considerably from biophase to biophase and from segment to segment. (See table V.) These performances are for single-pass data only. Multidate analyses in the intensive test sites resulted in a considerable performance improvement.

Estimates for the three parameters used in LACIE to quantify the area estimation accuracy were computed for the 28 segments analyzed. Two estimates of the bias were obtained for 12 (an arbitrary subset) of the 28 segments. The wheat areal proportion estimates obtained by LACIE were compared to the proportions as determined from the SRS sample units (1 by 1 statute mile) within the 5- by 6-nautical-mile segments. The results, shown in table VI, indicate the difference of 0.0035 to result in a negative bias (underestimate) in the LACIE estimate of minus 1.02 percent of the SRS mean value. In table VII, an aggregation of the LACIE results from the six crop reporting districts containing the LACIE segments agree to minus 3 percent with the 1973-74 SRS estimate over the same CRD's.

The accuracy of the LACIE area estimate was also estimated in two ways. In table VI, the standard error associated with the difference between the LACIE and SRS estimates in the 12 sample segments is about 12 percent of the SRS mean value over these segments. Projected to the area consisting of six CRD's, the associated standard error would be roughly 8 percent. In table VIII, the precision of the LACIE estimate is

TABLE IV.—INTENSIVE STUDY SITE SUMMARY OF AI PERFORMANCE

[Percent of fields correctly identified]

Biological phase	Morton		Finney		Ellis		Saline		Rice	
	W ^a	NW ^b	W	NW	W	NW	W	NW	W	NW
1A Fall seedbed preparation	27	100								
1B Spring reemergence	100	100	100	80	100	66				
2 Booting through heading	89	100	100	100	100	80	100	100		
3 Soft dough to harvest (mature)			100	100	100	80			100	100
4 Postharvest	100	100	100	100	100	100	100	100	100	100

^aW = wheat. ^bNW = nonwheat.

TABLE V.— CLASSIFICATION PERFORMANCE ON FIVE KANSAS

INTENSIVE TEST SITES

[Probability of correct classification]

Phase ^a	Segment and crop type ^b									
	1034 (Finney County)		1042 (Morton County)		1106 (Ellis County)		1111 (Rice County)		1114 (Saline County)	
	W	NW	W	NW	W	NW	W	NW	W	NW
1A			0.76	0.90						
1B	0.54	0.76	.73	.95	0.22	0.85				
2	.87	.61	.75	.79	.66	.31			0.78	0.82
3	.69	.89			.80	.19				
4	.38	.85	.38	.55			0.85	0.48	.78	.68
									.78	.65

^aNumbers correspond to biological phases listed in table IV.

^bW = wheat; NW = nonwheat

TABLE VI.— COMPARISONS OF SRS AND

LACIE ESTIMATE

Segment	County	Phase ^a	Wheat proportion	
			Landsat	SRS
1040	Kearny	2	0.322	0.337
1109	Marion	1	.254	.222
1036	Grant	1	.520	.321
1118	Reno	2	.180	.434
1018	Graham	2	.127	.182
1029	Scott	1	.400	.411
1037	Gray	1	.290	.266
1045	Stevens	2	.249	.209
1065	Haskell	1	.300	.321
1104	Barton	3	.380	.605
1106	Ellis	2	.607	.404
1110	McPherson	2	.526	.401
Mean: ^b			0.34625	0.34275

^aPhase numbers correspond to biological phases listed in table IV.

^bDifference in means = 0.0035; associated standard error = 0.0407.

TABLE VII.— A MAP COMPARISON OF USDA AND LACIE
WHEAT PROPORTION ESTIMATES FOR SIX KANSAS CROP
REPORTING DISTRICTS

Kansas CRD number	Wheat proportion		Relative difference, percent
	USDA (1973-74)	LACIE	
1	0.244	0.189	-22
2	.228	.230	1
4	.255	.214	-16
5	.307	.390	27
7	.267	.321	20
8	.385	.282	-27
All 6 CRD's	0.286	0.278	-3

TABLE VIII.— PRECISION OF LACIE
AREA ESTIMATIONS

Kansas CRD number	No. of segments		Precision, percent
	Allocated	Classified	
1	8	1	60
2	11	3	21.2
4	9	2	26
5	11	8	8.7
7	14	10	10
8	14	4	16
Aggregated	67	28	8.3

computed based on all 28 segments processed for each of the 6 CRD's examined and is computed for the aggregate of these. These are the precisions associated with the LACIE area estimation discussed in "Description of the LACIE." Notice that the precisions fluctuate with the CRD. This is a result of the fact that each CRD had a different number of acceptable sample segments and that the error of the ratio estimators

discussed earlier enters into these calculations. The precision of the LACIE estimate for the six CRD's is 8.3 percent.

Based on these preliminary results, an estimate can be made of the performance to be expected at a state level in Kansas. Assuming the bias of minus 3 percent to remain about the same at the state level, and (based on sample theory) assuming the precision will decrease in proportion to the square root of the ratio of the number of cloud-free samples acquired at the state level in Kansas (≈ 50) to the number examined here (28), a rough estimate of the precision at the state level would be

$$\sqrt{\frac{\text{Var}(\hat{p})}{\hat{p}}} = \sqrt{\frac{28}{50}} \times 8.3 = 6.2 \text{ percent}$$

(11)

For the bias figure of 3 percent, the confidence that the LACIE Kansas estimate will be to within 10 percent of the SRS state estimate would be approximately 85 percent.

Projecting this estimate beyond Kansas to the national level is probably not too meaningful at this time because (1) the Kansas results were obtained using only local signatures (i.e., signatures developed for each

segment without employing signature extension); (2) conditions in other states will vary considerably; and (3) of the 28 segments examined, data for 22 were acquired in biophase 1 (bare soil). However, the very preliminary evidence examined indicates that the confidence at a national level could increase considerably as a result of increased sampling.

It is concluded that this preliminary assessment shows every indication that the 90/90 criterion nationally is a reasonable goal to be achieved by the LACIE system and one which will productively stimulate the development of the LACIE technology.

REFERENCES

1. Remote Multispectral Sensing in Agriculture. Bull. 844, Laboratory for Applications of Remote Sensing (LARS), Purdue Univ., vol. 3, annual report, Sept. 1968.
2. Corn Blight Watch Experiment Final Report, Experimental Results. NASA SP-353, 1974.
3. Anuta, Paul E.; and MacDonald, Robert B.: Crop Surveys From Multiband Satellite Photography Using Digital Techniques. LARS Information Note 032371, Purdue Univ., 1971.
4. Williams, D. L.; Morain, S. A.; Barker, B.; and Corner, S. C.: Identification of Winter Wheat From ERTS-1 Imagery. Symposium on Significant Results Obtained From the Earth Resources Technology Satellite-1, vol. I, section A. NASA SP-327, 1973, pp. 11-18.
5. Thomson, Frederick J.: Crop Species Recognition and Mensuration in the Sacramento Valley. Symposium on Significant Results Obtained From the Earth Resources Technology Satellite-1, vol. I. NASA SP-327, 1973, pp. 181-187.
6. Bizzell, R. M.; Wade, L. C.; Prior, H. L.; and Spiers, B.: The Results of an Agricultural Analysis of the ERTS-1 MSS Data at the Johnson Space Center. Symposium on Significant Results Obtained From the Earth Resources Technology Satellite-1, vol. I. NASA SP-327, 1973, pp. 189-196.
7. Bauer, M. E.; and Cipra, J. E.: Identification of Agricultural Crops by Computer Processing of ERTS MSS Data. Symposium on Significant Results Obtained From the Earth Resources Technology Satellite-1, vol. I. NASA SP-327, 1973, pp. 205-212.
8. Erb, R. Bryan: The Utility of ERTS-1 Data for Applications in Agriculture and Forestry. Third Earth Resources Technology Satellite-1 Symposium, vol. I, section A. NASA SP-351, 1973, pp. 75-85.
9. Thompson, L. M.: Weather and Technology in the Production of Wheat in the United States. *J. Soil & Water Conserv.*, vol. 24, Nov. 1969, pp. 219-224.
10. Haun, J. R.: Prediction of Spring Wheat Yields From Temperature Precipitation Data. South Carolina Agricultural Experimentation Report, 1973.
11. Williams, G. D. V.: Estimate of Prairie Provincial Wheat Yields Based on Precipitation and Potential Evapotranspiration. *Canadian J. Plant Sci.*, vol. 53, Jan 1973, pp. 17-30.
12. Williams, G. D. V.: Weather and Prairie Wheat Production. *Canadian J. Agric. Economics*, vol. 17, no. 1, 1973, pp. 99-109.
13. Robertson, George W.: A Biometeorological Time Scale for a Cereal Crop Involving Day and Night Temperatures and Photoperiod. *Int. J. Biometeorol.*, vol. 12, no. 3, July 1968, pp. 191-223.

II. YIELD ESTIMATES FROM METEOROLOGICAL INFORMATION

Paul J. Waite^a

INTRODUCTION

The U.S. Department of Commerce National Oceanic and Atmospheric Administration (NOAA) has the responsibility to measure our environment and assimilate and analyze those data for application to promoting the safety, health, and well-being of our Nation's people. The NOAA data acquisition responsibilities include the three-dimensional atmosphere by way of a meteorological and climatological network of observational sites supplemented by meteorological satellites since the first launch on April 1, 1960. The NOAA communications center procures meteorological data on a global basis for analysis and application to provide meteorological forecasts and outlooks, and archived data are utilized for climatological assessments and application relative to all facets of our economy and human endeavor.

The NOAA Environmental Data Service (EDS) Center for Climatic and Environmental Assessment (CCEA), established at Columbia, Missouri, in 1974, recognized the importance of climatic changes upon world food production¹ and began developing crop-weather models for wheat from an assembled base of approximately 45 years of climatic records and historic wheat yield and production data at the stratum level (crop reporting district in the United States). Documenting the trend in yields because of changing crop varieties, rates of fertilizer, and culture practices is an important first step in yield modeling. Much of the yield variation in the technology trend had been identified as weather-related by Thompson (refs. 1 and 2) and other researchers in crop modeling.

CCEA WHEAT YIELD MODELS

The CCEA wheat yield models developed for the LACIE project are the modified regression form derived from 45 years of yield and climatic data. The yield data are obtained by aggregating the USDA Statistical

Reporting Service (SRS) final estimates of harvested acreage and production in bushels per harvested acre for each given region. The climatic data consist of the EDS National Climatic Center monthly averages of precipitation and temperature. The climatic data weighted to harvested acres for a given region were used to derive the model shown in figure 1.

The NOAA wheat yield models developed at CCEA at Columbia, Missouri, when fully implemented, will require the mass of global meteorological data provided by NOAA's National Meteorological Center at Suitland, Maryland. The yield models, as they are revised, will require additional meteorological satellite data provided by the NOAA National Environmental Satellite Service in Washington, D.C. The implementation of the yield models at the EDS-computer site in Washington, D.C., were scheduled to be accomplished during the summer of 1975. Additionally, the meteorologically driven adjustable crop calendars will also be operated in the Washington LACIE facility to provide timely yield estimates and crop calendar adjustments.

February truncation

$$\hat{Y} = 10.471 + 0.268(25) + 0.741(21) + 0.521(\text{AFP} - 10.271)$$

June truncation

$$\hat{Y} = 13.347 + 0.225(25) + 0.759(21) + 0.284(\text{AFP} - 10.271) \\ + 1.591(\text{MPP} - 0.796) - 0.139(\text{MPP} - 0.796)^2 - 0.299(\text{MP} - 3.540)^2 \\ - 2.453(\text{MDD}) - 0.133(\text{JP} - 3.809) - 0.119(\text{JP} - 3.809)^2$$

\hat{Y}	Yield estimate in bushels per harvested acre
AFP	August to February precipitation (in.)
MPP	March precipitation - potential evapotranspiration (in.)
MP	May precipitation (in.)
MDD	May degree days above 90° F (= 1 if degree days greater than 8.5, = 0 otherwise)
JP	June precipitation (in.)

Figure 1.— Truncated yield forecasts for 1975 by use of the Kansas wheat model.

^aNOAA, JSC, Houston, Texas.

¹J. D. McQuigg, "Climate Change and World Food Production," Frontiers of Science Series Address, University of Florida, 1975.

Climatic Variables

The modified regression models of the type shown in figure 1 are based on nonlinear climatic relationships with wheat yields. For example, too little or too much precipitation may be detrimental to wheat yields. To approximate this relationship, the climatic variables are coded in terms of departures and squared departures from normal, with normal defined as the long-term average of the climatic variable over the entire range of the historical data base. In addition to precipitation, an aridity index is derived for those months in which temperature and precipitation appear to significantly contribute to wheat yields. The monthly temperature value is converted into potential evaporation by using Thornthwaite's method and relating it to the monthly precipitation to provide the aridity values.

A stress index is computed to account for reduced yields resulting from hot, dry weather during the heading stage, by using "degree days" above 90° F, during the time of the crop-growing season most closely associated with heading time in that region. The averaged number of "degree days" is converted to a stress index (0,1 variable).

The same kind of weather can influence wheat yield differently, depending upon whether it occurs during rapid growth (jointing) or during the period of increasing kernel weight (filling). Similarly, the growing season begins on such varying dates, especially for spring wheat, that the same few calendar weeks might encompass jointing one year and filling another year. Obviously, it is desirable to know the stage of development of the crop each year to schedule satellite observation of its spectral characteristics or to estimate the influence of weather between specified calendar dates on yield. Air temperatures, day length, and, perhaps, moisture will be used to estimate the stage of development of wheat in areas not accessible to ground observation.

Yield Trends

The wheat yield models account for the technology trend by jointly assessing such effects as changing crop varieties, soil fertility variations, changing cropping practices, and other technological influences. Throughout the United States, the year 1955 is most widely identified as the approximate beginning of a rapid increase in wheat yields. The wheat yield increases coincide with the fact that little fertilizer was applied to the Great Plains prior to the early 1950's. In some regions (e.g., Oklahoma), the technology effect has

leveled off in recent years. (See fig. 2.) The Oklahoma yields appear to have increased rapidly from 1955 to 1960, but show little or no increase since 1960. Therefore, the linear trend lines change slope in 1955 and 1960 to account for technology changes in Oklahoma. For other states or regions, the changes in trend differ according to their technology. The U.S. models derived use one trend line to 1955 and one or more trends since then.

The models used to forecast yields throughout the crop season are the truncated type which use regression coefficients with climatological variables to a given cutoff point. For example, in figure 1 the truncation models for February utilize weather through February, and the June model uses the weather through June to estimate the anticipated yield. The models, developed with approximately 35 years of data to 1965, were independently tested on each of the remaining 10 years of data as if in real-time operation and compared with the SRS final yield estimates to derive a measure of yield accuracy for each state. Those LACIE yield estimates which compared favorably with the final SRS results were judged acceptable.

The NOAA has met its first obligation to LACIE by producing useful wheat yield models which are relatively simple and economical to operate. The first models account for much of the variation of wheat yields from the values derived from the historical, or average yields, and modified by the technological trends. The search continues for improved wheat models for LACIE. The improvements to the existing models and the new models sought are expected to better simulate the plant response to its growing environment. Haun, Hartley, Feyerherm, Kanemasu, and others (ref. 3) are actively seeking Nature's secret for better wheat yields by modeling the environmental inputs to wheat growth and development and monitoring rates of fertilizer application. Weather is being interpreted in stages of crop development, and the progress of the wheat crop is being viewed sequentially throughout the growing season as has been suggested by Robertson and Baier (refs. 4 and 5). The problem is not simple, but progress is being made.

The need for accurate food yield models becomes more imperative daily as the world's population increases, affluence rises, resources decline, including the dwindling grain reserves, and lifestyles change. As promising as they are, some of the new high-yielding wheats are particularly sensitive to abnormal weather. If climate, in its ever-changing pattern, continues its cooling trend, underway since around 1940, with increasingly stressful effects upon crops as exhibited in

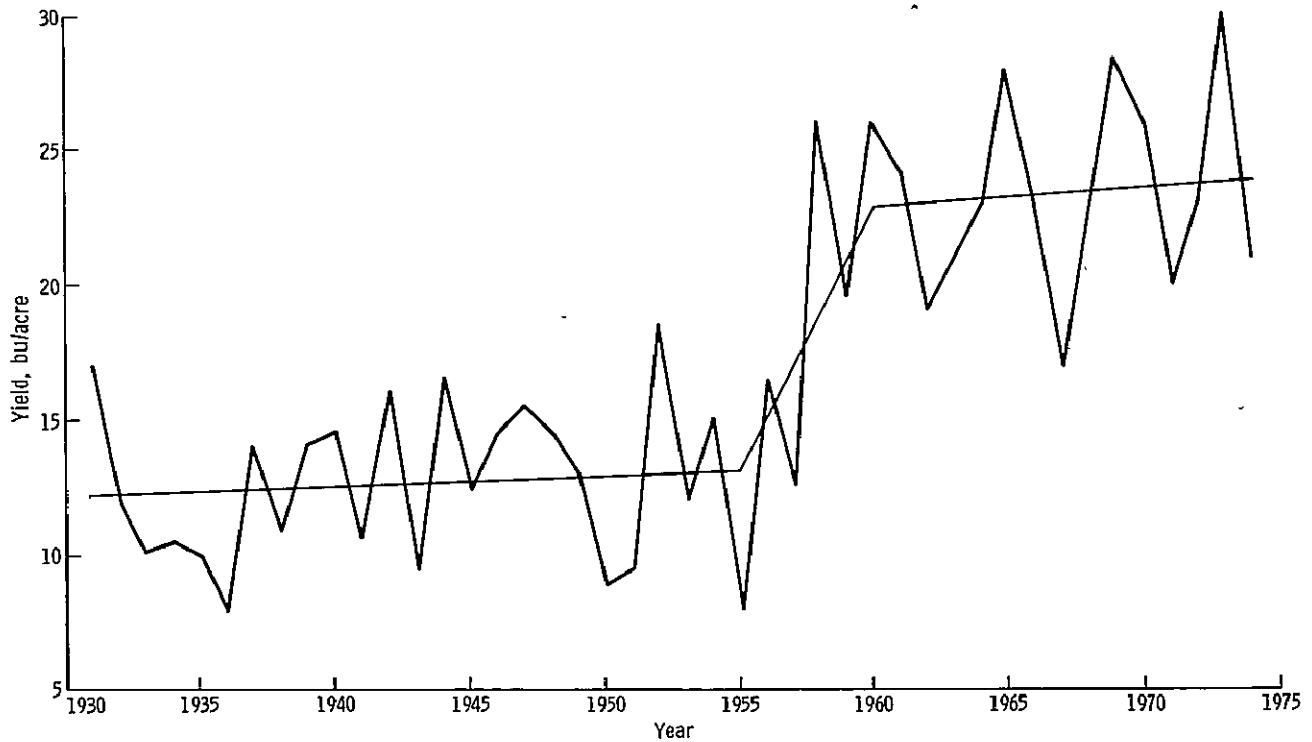

Figure 2.— Oklahoma wheat yields.

the 1970's, the need for careful climatic and crop monitoring becomes apparent. Triagency LACIE effort has come none too soon to develop and test the new acquisition and analysis techniques for monitoring the major food resource of wheat in a timely, accurate fashion year-round.

REFERENCES

1. Thompson, L. M.: Weather and Technology in the Production of Corn in the U.S. Corn Belt. *Agron. J.*, vol. 61, May 1969, pp. 453-456.
2. Thompson, L. M.: Weather Variability, Climatic Change, and Grain Production. *Science*, vol. 188, no. 4188, May 1975, pp. 535-541.
3. Pitts, D. E.; and Barger, G. L., editors: Proceedings of the 1974 Lyndon B. Johnson Space Center Wheat Yield Conference. NASA TM X-58158, 1975.
4. Robertson, G. W.: A Biometeorological Time Scale for a Cereal Crop Involving Day and Night Temperatures and Photoperiod. *Int. J. Biometeorol.*, vol. 12, no. 3, July 1968, pp. 191-223.
5. Baier, W.: Crop Weather Analysis Model, Review and Model Development. *J. Appl. Meteorol.*, vol. 12, no. 6, Sept. 1973, pp. 937-947.

III. A SYSTEMATIC APPROACH TO THE PRACTICAL APPLICATION OF REMOTE-SENSING TECHNOLOGY

Jimmy D. Murphy^a and Raymond I. Dideriksen^b

INTRODUCTION

The U.S. Department of Agriculture has a wide range of responsibilities in its efforts to enhance the environment and to maintain environmental production capacity by helping landowners protect soil, water, forests, and other natural resources. It works to improve and maintain farm income and to develop and expand markets abroad for agricultural products. Department programs in the fields of research, environment improvement, resource development and use, rural development, and agricultural production are essential to carrying out national growth policies. Its findings are of direct or indirect benefit to all Americans.

Critical to the management decisions that underlie these responsibilities are the collection, assimilation, and evaluation of timely and reliable resource and related information. In recent years, the rapidly changing domestic and world economic situation has further increased this need for current information. Historically, one source of information made available to USDA management has been based upon aerial photography. Conventional black-and-white photography has been, and is being, applied to day-to-day operations of USDA conservation and research programs. In more recent years, we have recognized the value of color, of infrared, and of the digital representation of multispectral media. This value became quantifiable in 1971 during the southern corn blight epidemic in the Midwestern States. Predicated on the experience gained during this research, and subsequent to the launch of Landsat-1, the USDA actively pursued interpretation and processing techniques in an attempt to evaluate this new technology on the basis of specific departmental data needs. The USDA agencies which provided the thrust of this research effort included the Statistical Reporting Service (SRS), the Forest Service (FS), and the Agricultural Research Service (ARS). The SRS located, identified, and measured agricultural crops; the FS located, identified, and measured national forest resources; and the ARS determined the spectral

properties of soils and plants. Other USDA agencies contributed findings from research in complementary fields.

Although these efforts addressed the capabilities of a new technology, the approach and end results were not necessarily correlated with precise and integrated information needs of the Department. Recognition of this situation by departmental management led to a series of specific activities designed to focus in-house expertise upon adapting remote-sensing technology to user data needs. In late 1972, a planning committee was created within the Department to develop a charter to guide the activities of a USDA Remote-Sensing User Requirement Task Force. The charter was prepared by the planning committee and formalized by a Secretary's Memorandum in August 1973. Simply stated, the task force, composed of representatives from each user agency within USDA, was charged with cataloging USDA requirements for Earth resources data, determining those requirements that would return maximum benefits by using remote-sensing technology, and developing a plan for acquiring, processing, analyzing, and distributing data to satisfy those requirements. Work continues to meet these goals.

Concurrent with the task force effort, national attention was focused on the near-term practical application of multispectral data to be provided by a second Landsat scheduled for launch by NASA in early 1975. Based on a preliminary NASA proposal to establish a joint experiment with the USDA, the Department assessed the potential value of complementing the task force efforts with a pilot experiment; as a result, they decided to participate in a large area crop inventory experiment. The LACIE would be designed to systematically integrate existing technology (e.g., satellite-acquired multispectral data, ground data handling techniques, ongoing research, current meteorological data, and advanced analytical techniques) for the express purpose of estimating production for a significant crop, wheat. Three Government agencies agreed to devote resources to this

^aU.S. Department of Agriculture, JSC, Houston, Texas.

^bUSDA Soil Conservation Service, Washington, D.C.

goal. In October 1974, an Interagency Memorandum of Understanding¹ was signed by NASA, NOAA, and USDA.

In this paper, the authors address the details of the USDA Remote-Sensing User Requirement Task Force and LACIE, and the interrelationship of these two activities.

THE USDA REMOTE-SENSING USER REQUIREMENT TASK FORCE

Secretary's Memorandum Number 1822² makes the Remote-Sensing User Requirement Task Force responsible for identifying those areas where the Department's needs for Earth resources information and data (user requirements) could potentially be fulfilled by using remote-sensing technology and related automated data processing, and for developing and evaluating a coordinated plan, including alternatives, that could be implemented in a cost-effective manner using remote-sensing and information-handling technology to satisfy Department and Agency Earth resources information and data requirements.

An ultimate product of these USDA efforts could be an operational remote-sensing information system that will satisfy many user information and data requirements for a variety of departmental programs with cost/benefits. An intermediate goal is a plan stating functions and requirements necessary for such a system with cost/benefit estimates. The plan would include information on costs, benefits, resource requirements, technology, capabilities, related operational and development activities of other Federal agencies, and other information that will be useful in determining how the Department might better carry out a program to use remote-sensing techniques and information more effectively. This plan could represent the first phase of further activities. Figure 1 depicts this planning rationale. Each phase will be followed by a major review/decision point before beginning the next phase.

The planning framework shown in figure 1 provided a basis for the systems approach described in the following subsections.

Approach to Data Collection and Analysis

The approach formulated as a result of an initial planning rationale was based on a clearly defined set of objectives within which the task force must operate. These objectives are to identify and describe the USDA user data requirements on an agency-by-agency basis, to prepare and publish a user requirements catalog, to perform an operational analysis of these requirements against existing and planned technology, to conduct a trade-off analysis (cost) against the current system in terms of labor, money, and materials required to implement alternative systems using remote-sensing technology, to develop alternative operational and development plans to optimize costs and benefits and prepare a research document, and to prepare a coordinated system plan to present to the Secretary of Agriculture.

Given these objectives, eight USDA agencies with significant operational programs in the Earth resources area were identified. They were designated user agencies and were responsible for listing requirements which could be satisfied using remote-sensing technology. These were the Agricultural Stabilization and Conservation Service, the Animal and Plant Health Inspection Service, the Economic Research Service, the Extension Service, the Foreign Agricultural Service, the Forest Service, the Soil Conservation Service, and the Statistical Reporting Service.

Each of these agencies designated a representative to the task force and appointed a subcommittee to assist the agency representative in cataloging its Earth resource data requirements. Advisory representatives were named from the Agricultural Research Service, the Cooperative State Research Service, the Office of Information Systems, the Office of Planning and Evaluation, and the NASA.

The advisory representatives are furnishing the task force technical assistance as required in areas such as benefits assessment, information systems requirements, research findings, and technical hardware capabilities. The diversity in expertise of the task force representation necessitated an intensive training session in remote sensing, automated data processing,

¹Memorandum of Understanding Among the U.S. Department of Agriculture, the National Oceanic and Atmospheric Administration, and the National Aeronautics and Space Administration for an Experimental Large Scale Crop Inventory Demonstration, LACIE, USDA, Office of the Secretary, Washington, D.C., October 10, 1974.

²Secretary's Memorandum Number 1822, Remote-Sensing User Requirement Task Force, USDA Office of the Secretary, Washington, D.C., August 17, 1973.

multispectral analysis techniques, USDA management information concepts, individual agency missions and their research activities in related fields, and procedures to be followed in determining user requirements. During the 2-week session, other Government agencies, universities, and NASA provided discipline expertise.

Once underway, the task force followed the task-oriented model depicted in figure 2. Within the activities described by this model, it is appropriate to discuss briefly the accomplishments to date, the current status, and the remaining tasks.

Accomplishments to date.- The task force has been in operation for just over a year. During this time, more than 3000 user requirements have been identified and quantified in terms of data accuracy, reporting cycles, areal extent, and units of measure required. These requirements have been further indexed as to USDA mission, operating goals, and programs. Finally, a third level of data correlation has been applied to the requirements. The six major data categories within this

level are natural resources, works of man, ownerships, land and water use, political and legal constraints, and socioeconomic. All quantifiable data elements described are now in an automated data base which allows the task force to provide management with information on the data essential to agency programs, identify commonality of requirements between agencies, and consider unified sources for providing required data.

The results of this approach to data collection and requirements description provide an efficient and ordered input to the next analytical step.

Current status.- The USDA task force is currently engaged in the startup activities associated with the requirements analysis. The purpose of this effort will be to screen the USDA user requirements catalog and to identify a smaller number of requirements by functional categories. These requirements will be tested against current systems and alternative remote-sensing systems that are within acceptable technological capability and have large benefits relative to cost. The requirements

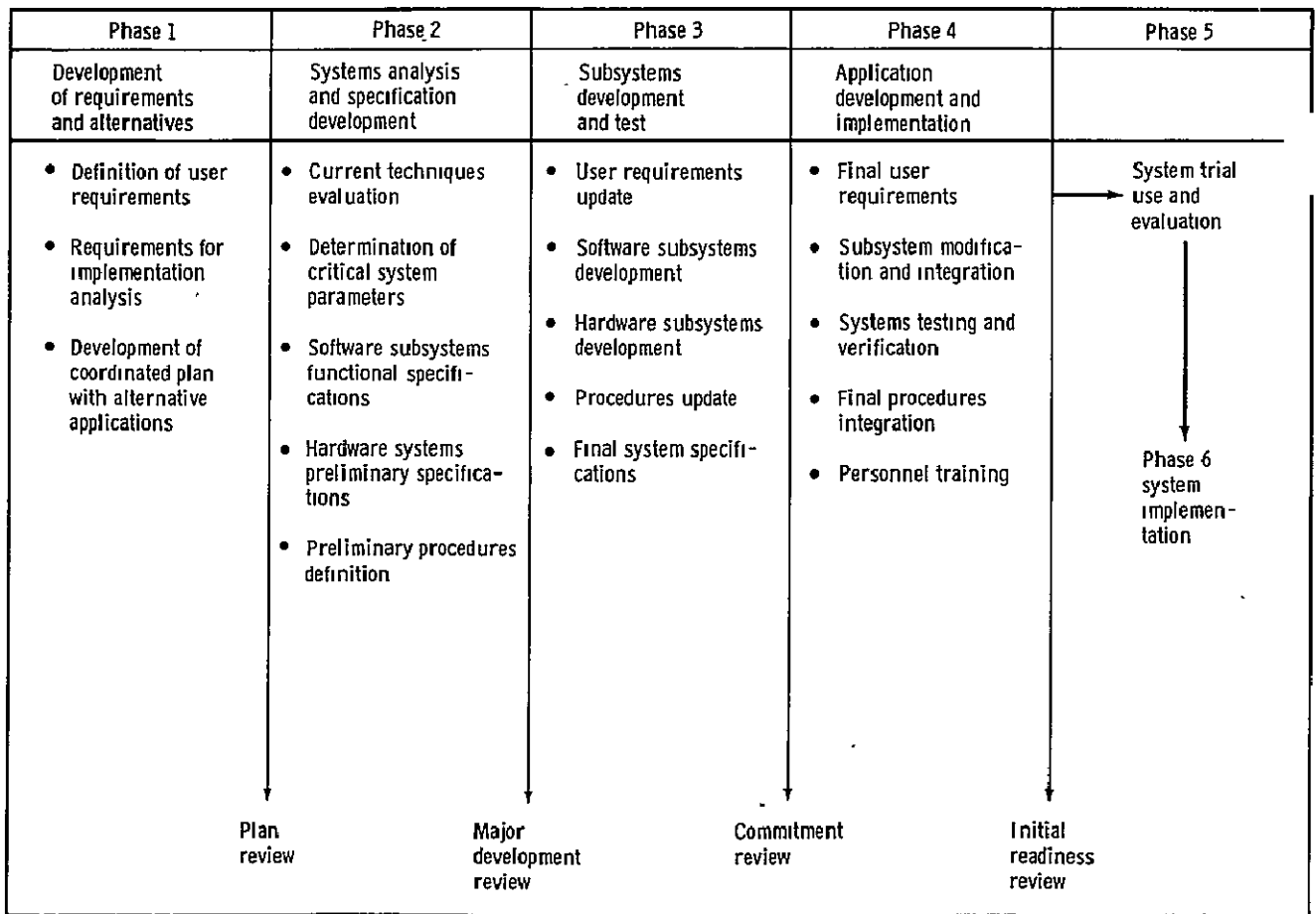

Figure 1.- Preliminary plan schedule (long-range objectives).

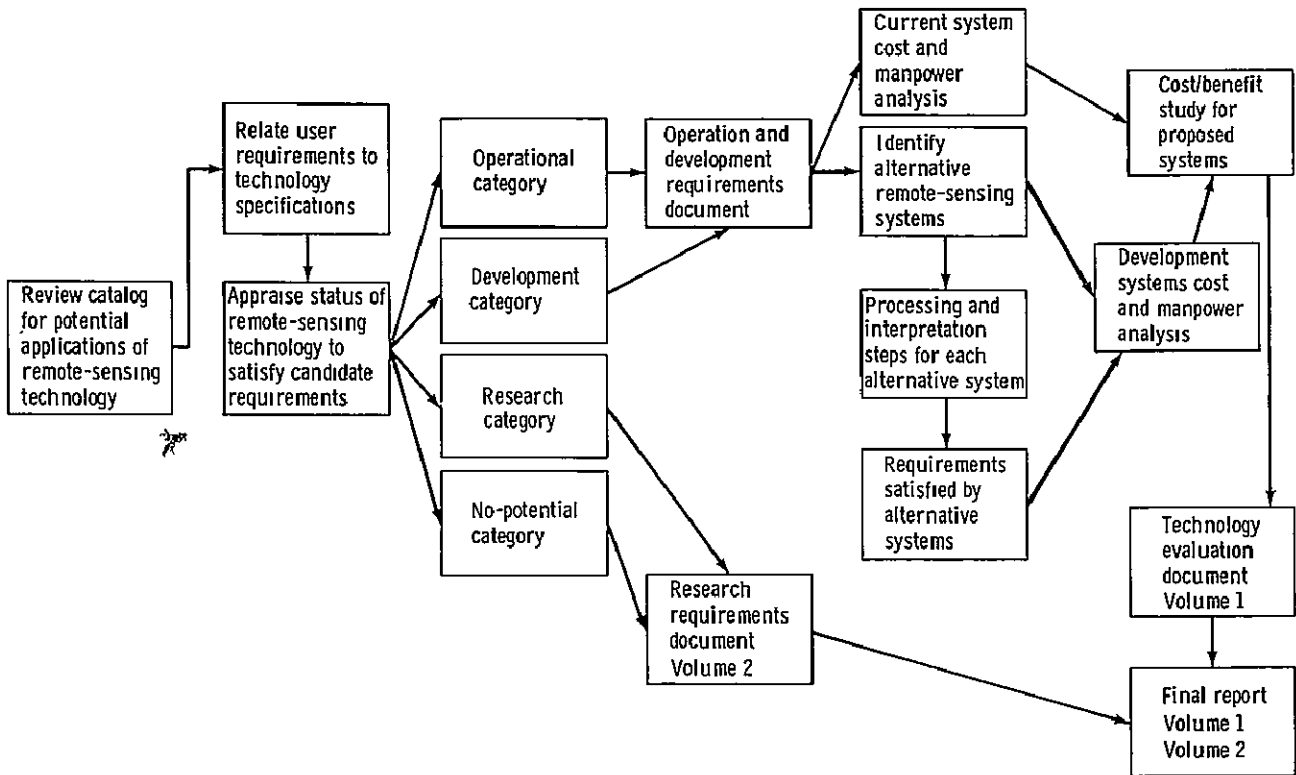

Figure 2.— Sequential flow of activities for requirements implementation analysis subtask.

having potential for application of remote-sensing technology will be analyzed and restated in terms of technical specifications. The status of remote-sensing technology will be appraised relative to the candidate USDA user requirements and to the implementation potential of each requirement, placed in one of several categories of technology status (research, development, operational, or no-potential). An operation and development requirements document will be prepared to record areas of operation and developmental systems where current user requirements are supported or could be supported if operational technology were available. A research document will identify requirements that need further study. The candidate USDA user requirements that could have existing or developing remote-sensing technology applied for possible consolidation in a coordinated plan will receive further study.

The requirements analysis will be conducted by teams of discipline experts from Government, universities, and nonprofit consulting firms. This phase of the task force effort is expected to be completed in late 1975. The output from this operational analysis will serve as input to the remaining analytical tasks.

Remaining analytical tasks.— Task force efforts which remain to be completed include a cost trade-off in dollars and manpower necessary to implement those applications that have technical feasibility and potential for accruing significant benefits. Requirements in the research and no-potential categories will not undergo a cost/benefit analysis. All user requirements, regardless of their category — operational, developmental, research, or no-potential — will be submitted to further analysis for remote-sensing implementation. This analysis will identify commonalities which may allow grouping of the requirements into application subsystems that could be implemented in a coordinated development plan with alternative design approaches; e.g., identification and measurement of open rangeland, its estimated carrying capacity, and the precise delineation of national forest boundaries and/or agricultural areas. Identification, measurement, and carrying capacity may be satisfied through a system designed around a satellite multispectral scanner and a weather satellite. The precise delineation of administrative or legal boundaries may best be satisfied through a yearly coverage using high-resolution, black-and-white photography. Through

this example, one may perceive the necessity for an integrated planning step prior to submitting final implementation recommendations to USDA management.

Finally, an integrated developmental and implementation plan providing indications for activities the Department should emphasize during the next decade will be submitted to the Secretary.

The Need for a Pilot Project

As with any relatively new technology, success in practical application does not rely on isolated research efforts, but on a pilot, prototype, benchmark, or breadboard system that brings all facets of technology together against a single-thread user requirement. The essence of this proven systems concept applies to the ongoing analytical tasks being addressed by the USDA task force. Prior to, or in parallel with, any realistic estimation of cost trade-offs for an integrated research, development, and implementation effort, quantified hands-on experience with the technology must be documented. For USDA, this experience is being gained through joint efforts with NASA and NOAA in the large area crop inventory experiment. Through design, the LACIE schedule is structured to provide quantified performance data to the USDA task force's remaining analytical efforts.

THE LARGE AREA CROP INVENTORY EXPERIMENT

The LACIE is a cooperative effort involving NASA, NOAA, and USDA specifically oriented toward developing a data handling, processing, and analysis approach combining data from existing multispectral scanning equipment on the Landsat satellite, meteorological data from operational NOAA environmental satellites as well as from existing ground meteorological stations, and data from the conventional agricultural data base.

The general overview of USDA goals can best be summarized by the following excerpts from a statement given by Clayton K. Yeutter, Assistant Secretary for International Affairs and Commodity Programs, U.S. Department of Agriculture, to the U.S. House of Representatives, Committee on Science and Technology, February 4, 1975.

"... One of the possibilities we are most interested in is the use of satellite data in combination with other data to predict crop yields. Using data from Landsat-2, USDA will participate in LACIE, a quasi-operational test of an information system which could significantly improve the continuity and context of crop production forecasts. This project is a study to determine the utility and cost-effectiveness of using Earth resources satellite data in conjunction with meteorological and climatological data to predict production of wheat, a food grain of major importance. In its initial phases, LACIE will concentrate on the major wheat-producing regions in the United States. Based on evaluations of the initial phases, LACIE may be expanded to other areas and eventually to other crops. New information from LACIE would, of course, be available to other users, both domestic and foreign. USDA will thoroughly evaluate the LACIE system design, yield, and acreage estimation techniques, and data produced in the initial phases. LACIE will also provide the basis for analyzing the cost-effectiveness and utility of data collected by remote sensing versus conventional techniques — considering such factors as accuracy, timeliness, and continuity of data. Eventual use of this technology by USDA will be predicated upon value for dollars invested in fulfilling responsibilities to the American producer and consumer and on the needs of emerging countries.

"If successful, LACIE could lead to an operational agricultural crop forecasting system of major benefit to the United States and to the world. Such a system, using remotely sensed data in conjunction with weather, climate, and traditional agricultural information sources, could (1) provide a new capability for the United States and other countries in managing agricultural production and inventories to reduce fluctuations in price and volume of trade; (2) provide near-real-time indications of crop diseases and insect infestations which could affect world food supplies; (3) provide earlier warning of impending crop shortfalls due to adverse weather; (4) provide improved production estimates to international organizations such as the Food and Agriculture Organization for use in assisting developing countries in making rational marketing decisions. The development, testing, evaluation, and eventual implementation of a system which would be capable of providing routine repetitive international crop forecasts would, of course, be dependent on a continuing flow of multispectral data which is (1) available to the user in near real time; (2) repeated at frequent intervals throughout the growing season; and (3) delivered in computer processable form...."

The subsequent sections of this paper describe the USDA responsibilities within LACIE, the time frame of LACIE, the role of user requirements inherent to a technical approach, and the concept for transferring LACIE modules to a USDA operational environment.

U.S. Department of Agriculture Responsibilities

Within mutually agreed upon policies reflected by the joint Memorandum of Understanding and the LACIE Project Plan,³ USDA has lead responsibilities in the following areas: specification of user requirements, definition and evaluation of output products, collection of ground truth and historic agricultural data for input to models, preparation and dissemination of production estimates, application of a cost/benefit analysis to the LACIE approach, and definition of system changes necessary to convert the prototype LACIE system into a fully operational USDA system.

These responsibilities allow the USDA, as a user agency, to exercise significant influence in the technical conduct and evaluation of LACIE. Additionally, within the framework of specific responsibilities, USDA can ensure that appropriate performance assessment feedback is provided to the Remote-Sensing User Requirement Task Force. Finally, within USDA, certain responsibilities for the conduct of LACIE are spelled out in Secretary's Memorandum Number 1870,⁴ which established LACIE. Of particular interest in this memorandum is a departmental commitment of multiple agency resources to ensure orderly development of USDA's technical role within LACIE. Specific USDA organizations providing technical expertise within the overall responsibilities are Foreign Agricultural Service, Economic Research Service, Statistical Reporting Service, Agricultural Research Service, Soil Conservation Service, and Agricultural Stabilization and Conservation Service.

The LACIE Timetable

The USDA considers LACIE an investment to develop an operational system for use within USDA. To accomplish this, we have specified that LACIE will span 3 crop years. During the first year, programs and test techniques will be developed over selected areas of the United States. Also, Landsat data will be extracted for

other areas and processed to the extent of system capability. In the second year, we will test the capability to estimate acreage and production for the United States using the U.S. reporting system as a baseline for validation. To the maximum extent possible, new techniques and associated research, e.g., signature extension and yield techniques, will be subjected to extensive performance testing. Dependent upon the measured success of LACIE during the second year, a USDA decision will be made as to what approach should be followed for the third year; e.g., revalidate results of the second year, or attempt further expansion. This time-phased approach is depicted in figure 3, LACIE schedule, level 1. The time-phased development provides a basis for overview of the LACIE technical approach.

USDA User Requirements

In keeping with our pragmatic approach on applying remote sensing to USDA data needs, the authors contend that user requirements must guide a development effort involving new technology. This is a time-proven course to follow regardless of the appeal of new technology. Years and billions of dollars later, those of us who matured in the field of automated data processing have learned this fact of life. Relating these lessons to LACIE, the USDA has developed a comprehensive set of user requirements that provide the development guidelines for LACIE. These requirements, coupled with current remote-sensing and meteorological technology, provide realistic guidance to the LACIE technical approach.

Technical Approach Details of the LACIE

Details of the LACIE technical approach can be found in project documentation and will not be described in depth here. In fact, elements of the techniques being applied here, to a large extent, are the subject of the symposium. We will, however, provide an overview to the approach so that a reader may better understand the correlation between LACIE and the objectives of the departmental task force.

Identification and measurement of wheat. The primary thrust of this developmental effort is to bring to bear elements of remote-sensing technology (near-real-time satellite data, sampling strategy, pattern

³LACIE Project Plan, National Aeronautics and Space Administration, LACIE Project Office, Houston, Texas, February 1975.

⁴Secretary's Memorandum Number 1870, LACIE, USDA Office of the Secretary, Washington, D.C., April 8, 1975.

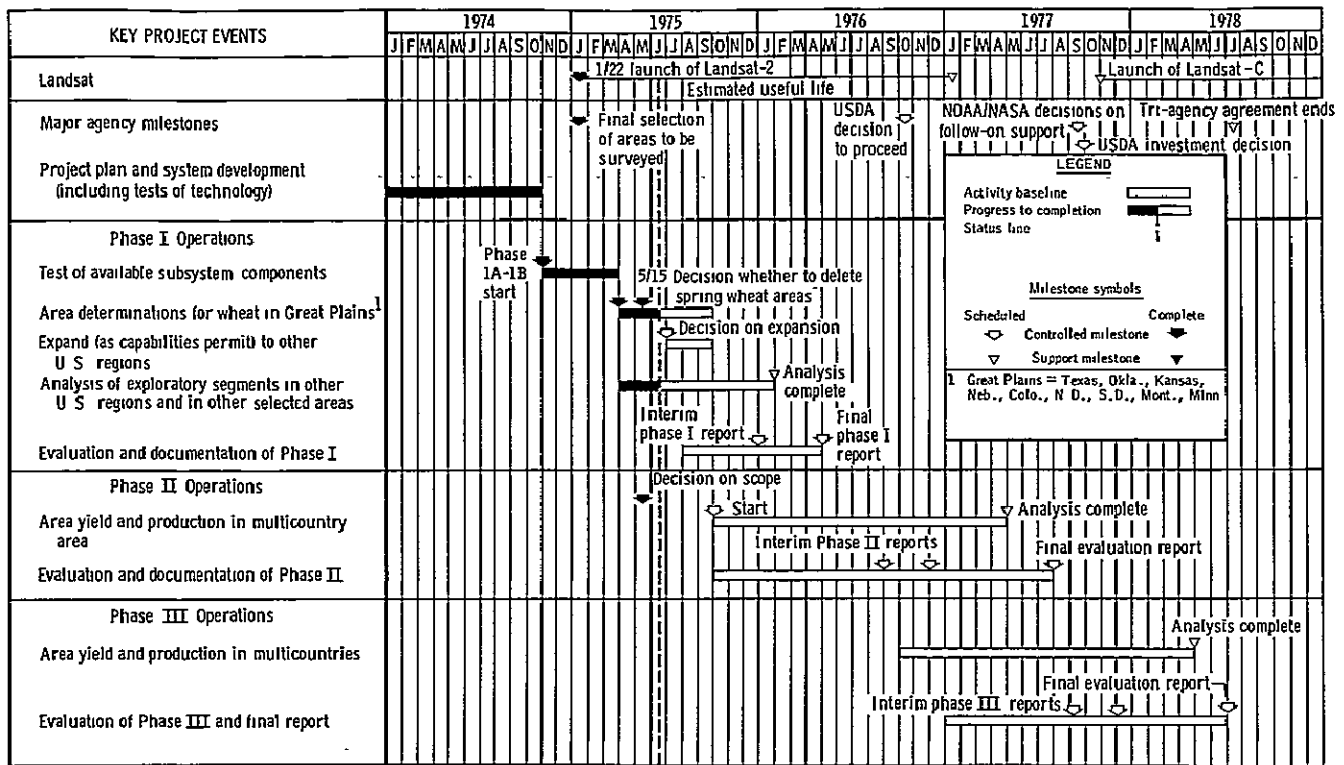

Figure 3.— LACIE schedule, level 1.

recognition techniques, man-machine interactive analysis techniques, and third-generation data processing capability) on a specific user problem. Sampling strategy is the foundation for this element of the technical approach. A brief discussion of identification and measurement will be built around this cornerstone. Several facts must be understood from a user viewpoint as a prelude to the discussion. One fact is that Landsat collection systems can deliver far more data than any one user can assimilate in a timely manner. The other is that conventional photointerpretation techniques are neither timely nor cost effective as alternatives in the repetition analysis for millions of acres of ground cover that undergo periodic phenological change. Within this context, the LACIE approach is designed to make maximum use of the minimum volume of data to satisfy the goal of crop area estimation. Specifically, the total areal extent of a crop to be surveyed is delineated, and a sampling strategy is designed on the basis of this total area.

For LACIE, the sample encompasses 2 to 2.5 percent of the total area for which Landsat data will be collected and processed, or approximately 5000 sample segments 5 by 6 nautical miles in size.

Twenty percent of the sample segments will be designated as training segments. These segments (approximately 1000) will provide the environment within which the analyst, using computer-aided recognition, ensures data quality. Crops in selected fields (30 of approximately 300) within each training segment are identified by a trained analyst for input to the computer. From an area standpoint, manual interpretation amounts to five ten-thousandths of the total LACIE area.

Completion of computer training as previously described establishes the mechanics for the automated system to extend classification (those areas planted to wheat as identified by their spectral reflectance) to all other sample segments, and to aggregate the percentage of wheat to nonwheat for the total sample area. Figure 4 graphically depicts this approach. The reader must be cautioned that, underlying this summation of a technical approach to area estimation, a number of technical problems exist that must be solved prior to implementation of a LACIE-like system; e.g., signature (spectral identity and differentiation of ground cover) extension from point A to point B with consistent results, and validity/reliability of a sampling strategy.

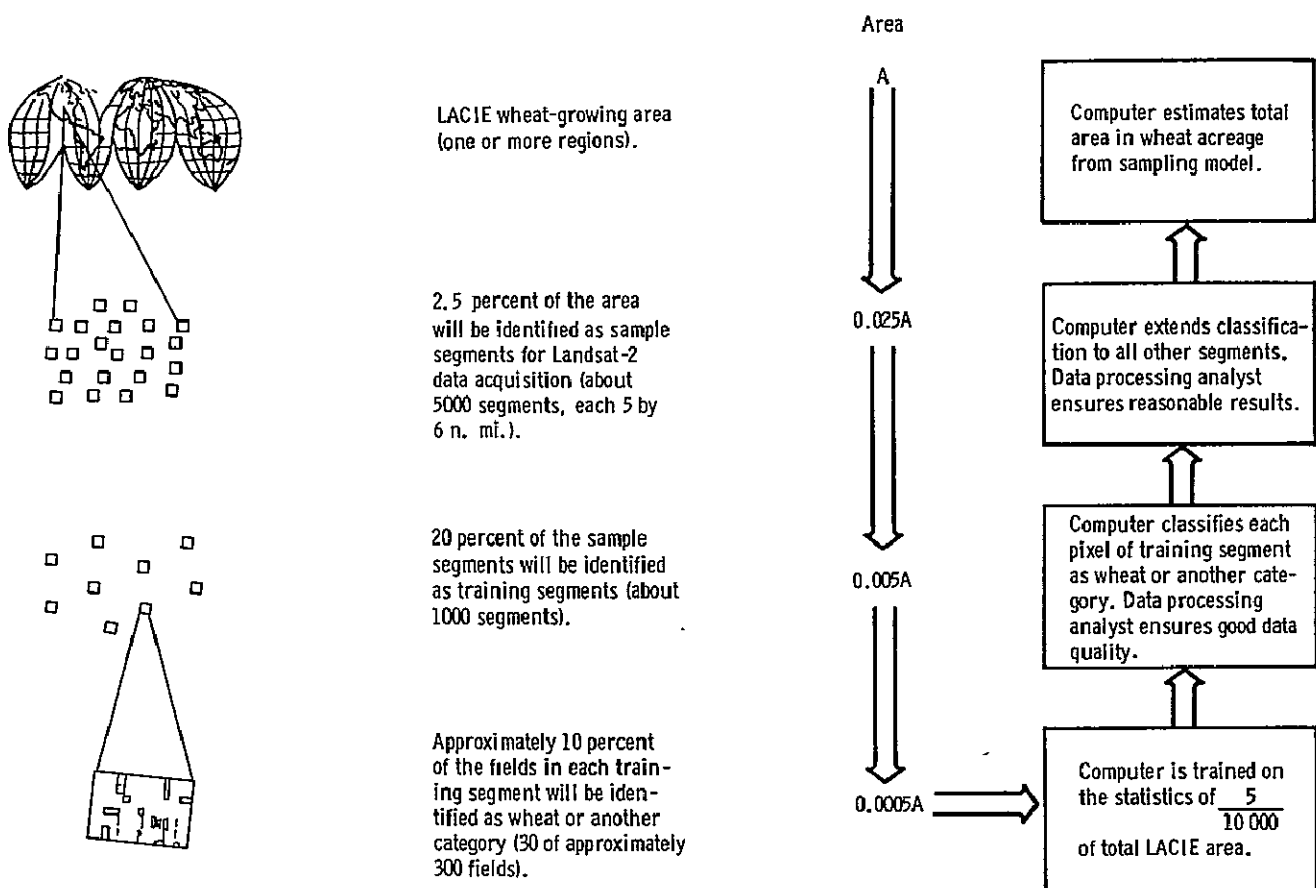

Figure 4.-- Area estimation approach.

Yield Determination.- Yield is a function of historical yield, soil, crop variety, and cropping practices as these factors respond to changes in meteorologic variables (such as temperature and precipitation) within the wheat-growing areas. Yield determination will be approached using statistical models in which development can generally be outlined as follows.

1. Determine the boundaries of the strata over which wheat responds relatively uniformly to its environment.
2. Choose the parameters to be used for yield prediction. (Parameters may vary with phase of growing season and location.)
3. Choose the form of model to be used. (Initially, NOAA will use an adaptation of the Thompson model, as shown in figure 5.)
4. Determine coefficients to be used with the model.

Yield will be computed monthly by stratum which relates to an area associated with meteorological reporting stations and location of LACIE area samples previously described. Closely associated with the determination of yield and the identification of wheat is

the development and maintenance of crop calendars. In-season crop calendars are the responsibility of NOAA and are adjusted through current weather data for a growing area; USDA historical crop calendars and yield data provide the basis for much of the yield development information required by LACIE.

Production estimation.- The product of an acreage-times-yield equation is production. Accurate and timely production estimation is the end goal of LACIE and USDA. It must be understood that LACIE production estimates are not simply an $A \times B = C$ equation. The LACIE is but one source of data input to an intricate analysis and reporting system managed by USDA. It is the system that LACIE must support and improve. As indicated earlier in this paper, user information requirements and decisionmaking processes must be enhanced in a quantifiable manner; e.g., timely, accurate, and reliable information correlated to decisionmaking.

To this end, LACIE is designed to provide an aggregation technique that allows the USDA analyst to

$$\begin{aligned}
\text{Yield} = & A + B [\text{trend function}] + C [\Delta \text{rainfall (Aug-Mar)}] \\
& + D [\Delta \text{rainfall (Aug-Mar)}]^2 + E [\Delta \text{rainfall in April}] \\
& + F [\Delta \text{rainfall in April}]^2 + G [\Delta \text{temperature in April}] \\
& + H [\Delta \text{temperature in April}]^2 + I [\Delta \text{rainfall in May}] \\
& + J [\Delta \text{rainfall in May}]^2 + K [\Delta \text{temperature in May}] \\
& + L [\Delta \text{temperature in May}]^2 + M [\Delta \text{rainfall in June}] \\
& + N [\Delta \text{rainfall in June}]^2 + O [\Delta \text{temperature in June}] \\
& + P [\Delta \text{temperature in June}]^2
\end{aligned}$$

- The coefficients A, B, . . . P, for each region are determined empirically from existing historic yield and meteorological data
- The coefficients vary from region to region because of differences in climatological and agricultural factors between regions
- During a growing season (prior to harvest), the meteorological variables consist of measured (in this example modified by coefficients C through H) and predicted components (modified by coefficients I through P). If normal conditions are predicted, the deltas in the predicted component are zero.

Figure 5.— An example of an agromet model used to compute yield by station or by stratum. This is the Thompson model used for the Kansas yield prediction.

stratify production estimates from relatively small areas, such as a county, upward to national estimates. To accomplish this aggregation, the analyst must have at his disposal an interactive system that allows access to an integrated data base containing all supporting data (crop calendars, soils data, summary weather information, acreage estimates, historical acreage, yield and production, etc.) necessary to make timely and reliable inputs for decisionmaking. The USDA user requirements document specifies this kind of system design.

Transferability of LACIE to the USDA

Integral to the technical approach described for LACIE is the explicit requirement for the final design of an operational application. From the USDA view, we consider LACIE to be comprised of a number of modules (hardware, software, procedural, and research efforts). It is our goal to submit these modules to extension evaluation and subsequent redesign as appropriate. The result will be a design effort as

conceptualized in our user requirements document. In this development context, we will specify and implement a transitional system using the experimental LACIE as a test medium. This transitional system should be designed in parallel to LACIE and take full advantage of those LACIE components (hardware, software, and procedures/techniques) that, through exhaustive evaluation, have met USDA user requirements, technical accuracy/feasibility requirements, efficiency in performance, and cost-effectiveness criteria. The primary design criteria to be followed by USDA are summarized in the following paragraphs.

Hardware in support of LACIE must consist of general-purpose, state-of-the-art computer and peripheral devices. Secondly, hardware must be compatible with existing USDA mainframes, communications, and interface protocols. Software must also follow compatibility rules and be vendor maintained. Application software (user support as opposed to system control) must be within the Federal standards subscribed to by USDA. Data base design must be efficient and integrated and its content structured so as to reduce redundancy and provide ease of access by application software. Data base integrity must be designed for user control and monitoring. Facilities to house the LACIE system must have adequate physical security features to allow application of commodity estimation lockup procedures. Personnel required to operate and manage a LACIE-like system are considered to be that number and discipline mix currently assigned to the experiment. Support services are unknown at this time; however, they are stated in the sense that current NASA support personnel and contractors are not considered necessary to the future use of an operational LACIE.

The transferability concept and its associated design criteria illustrate the importance of USDA involvement in LACIE and substantiate the value of this involvement to the Remote-Sensing User Requirement Task Force efforts.

In conclusion, the authors have described the carefully planned approach of the USDA to the practical use of a new technology. We are concerned with two specific goals. These are (1) to identify, specify, and quantify those user information needs that can be satisfied using remote-sensing techniques; and (2) to participate in the research and test of a pilot system that supports a real application need within the Department and that produces results which can be transferred to an operational environment. We believe that this planning approach will lead to success.

International Aspects of Earth Resources Survey Programs

Arnold W. Frutkin^a

The LACIE program illustrates very well the inevitable thrust of data requirements toward the global dimension. I think we will see this in many other programs as well, as we strive to cope with the regional and global parameters that are important for resource and environmental monitoring. As has been indicated, the large international participation in this symposium also warrants some discussion of the international aspects.

With regard to the history of the international aspects of the program, I should say that the Landsat program is international, not for any unique reason, but because of a clear and deliberate policy within the space agency, from its inception, that essentially all of its program be open to international participation. There have been essentially three lines sketched out for international participation in the Landsat program. The first of these anticipated the satellite phase and focused on that period in the middle and latter parts of the 1960's when aircraft were used in the development of multispectral sensors and other equipment destined for later use in satellites. In the course of that program, we enlisted the participation of Brazil and Mexico in the development of ground truth and in training programs looking toward the satellite phase.

In the second approach to international participation, we used the same mechanism which is employed in virtually all of NASA's programs: early announcement of experimental opportunities. This means that NASA defined the future Earth resources program and then, using many channels, invited both the domestic and foreign communities to submit proposals for their use of data to be derived from the Landsat spacecraft. Those proposals were then evaluated and selections were made on the basis of merits. The only significant difference in treatment between the foreign participation and the domestic participation was that, in all cases, the foreign participants were expected to pay their own costs. The

result has been that through the Skylab and Landsat projects, there have been more than 200 principal investigators from abroad from approximately 55 countries and 5 international organizations.

The third line of approach to foreign participation has been in the area of ground stations. About 1970, our colleagues from Canada proposed to NASA that they convert a ground station so that it might receive Landsat data directly. That was done under a bilateral agreement between NASA and the appropriate Canadian agency. Since that time, additional countries have entered into such agreements, so that today, in addition to Canada, Brazil, Italy, Iran, and Zaire are already operating stations, or will be shortly.

In these international agreements, there is, in a sense, a quid pro quo: NASA makes the satellite available, and the station operator undertakes to supply NASA with such data as it may require if the tape recorders fail. And so, there is a certain assurance for NASA in the operation of these stations. In addition, the later agreements provide that the overseas stations will take on the burden of supplying data within range of their stations to those principal investigators who have been selected by NASA.

A very wide range of international benefits has been realized from these agreements. In Bangladesh, for example, Landsat imagery has enabled investigators to recognize the process of land accretion taking place in the Bay of Bengal. Bangladesh has, as a consequence, been able to monitor the steady buildup of sediment (an estimated 150 million tons annually) washed down from the Himalayas. Images taken in 1973 revealed approximately 4000 square miles of newly added land; a year later, that estimate had more than doubled. This process has important implications for the economic and demographic future of a land whose resources are being subjected to the pressures of growing population. An estimated 10 percent of the new land is currently being

^aNASA Headquarters, Washington, D.C.

cultivated, and an extensive program of land development is now underway based on the data derived from Landsat.

In Norway, Landsat has proved very useful in monitoring snow cover for the management of water reservoirs. Norwegian investigators have reported that timely analysis of Landsat data can help avoid severe flooding and, in turn, permit better use of Norway's hydroelectric resources. In consequence, Norway is one of many countries currently considering establishing its own Landsat data acquisition facilities.

In Bolivia, Landsat imagery permitted selection of a new, shorter route for a previously planned natural gas pipeline. The shorter route resulted in a saving of more than \$3 million in construction costs. Landsat imagery is also being used to identify the best route for new Bolivian highways and railroad lines. And in a recent instance, the Bolivian Ministry of Transportation and Communications revised plans for a new highway after Landsat imagery revealed that the original route would run over a major geological fault.

Most of us are familiar with the remarkably extensive corrections that have been made to the mapping of the Amazon Basin as a consequence of an analysis of Landsat imagery. It is important to appreciate the economic implications from this kind of gross correction in mapping data for the selection of routes and construction of highway systems, for river navigation, and for development projects in general.

It is obvious, in looking at these cases, that a single successful application in the course of a year will probably compensate a nation for all of the costs of operating a station in that year.

Landsat and Skylab data have also been used extensively by the specialized agencies of the United Nations; namely, the Food and Agriculture Organization (FAO), the United Nations Development Program (UNDP), and the World Bank. For example, Landsat imagery, taken before and at the height of recent flooding in Pakistan, assisted World Bank and Pakistani officials in making a quick, accurate determination of the extent of flooding and in directing timely aid to farmers attempting to reclaim their cropland. In a number of places where claims were in dispute, the information from Landsat imagery contributed to their prompt settlement. Moreover, the World Bank is beginning to make routine use of Landsat data in its development projects. For example, Bank personnel report that Landsat imagery was used to determine the best site with an adequate water supply for the new agricultural settlement in Nepal; as a result, 6 months of project development time was saved. Landsat data are

also being used successfully to monitor the performance of contractors in large-scale developmental projects. One could go on citing examples of this kind, but I think it is important simply to underscore the fact that economic applications are already being made in the course of this experimental program.

In my opinion, the most significant factor for the future on the international side is the proliferation of ground stations. I believe it is reasonable to expect that the number of stations currently abroad will have at least doubled in 2 years. These stations will assure fuller, more certain local coverage than the tape recorders can supply. The stations will bring data processing and data availability closer to the user. They will spread the physical and economic responsibility of data processing. And, if combined with training and data analysis facilities, it seems inevitable that ground stations will be a powerful tool for local developmental applications. They will also contribute to meaningful technical and political ties on a regional basis.

With this proliferation of regional stations, we will have a sort of synergistic growth of applications on a regional and national level everywhere. A good example is Africa where the Italian station will provide coverage of the northern tier; the Iranian station will cover a large section of the northeast coast; and the station scheduled to go into Kinshasa in Zaire will almost cover the rest of the continent except for the very southern tip and a wedge on the western bulge. This means that the African nations can look to the appropriate station for coverage of their environmental and resource interests through Landsat imagery. There is no doubt that, as a consequence, there will be a considerable stimulus to use that data and that a rather advanced regional system will develop. In fact, in February, the Economic Commission for Africa voted to pursue the establishment of the station for the continent, and the French Government is interested in converting a tracking station in Ouagadougou in Upper Volta to cover that wedge in western Africa which is not now covered. I think that the African situation is just an illustration of what will happen elsewhere.

I think the United Nations has recognized this process and has, in effect, given its endorsement. I should like to read you a recommendation, framed recently in a subcommittee of the U.N. Outer Space Committee, insofar as it relates to this subject area.

"The subcommittee noted with satisfaction that a number of receiving stations had already been set up, or were planned, such as those in Brazil, Canada, Italy, Iran, and Zaire, to work with the Landsat program under bilateral agreements with NASA.

"The subcommittee recognized the importance of these receiving stations with the help of which a fairly wide coverage of most of North and South America, most of Europe, and large parts of Africa and West Asia could be assured even when the satellite-borne tape recorders ceased to function

"The subcommittee expressed the hope that countries in other regions would set up similar stations, that all countries planning to set up such stations would associate with them data storage, data dissemination, and training facilities that could be made available on reasonable terms to other countries in their regions."

In this context, the subcommittee further felt that "... Countries contemplating the establishment of stations might, if they considered it appropriate, at an early stage of their planning consult with other countries in their region in order to examine the feasibility of setting up such stations on a basis of regional collaboration, in such matters as organization, staffing, and training and to examine, taking into account possible corresponding plans of neighboring regions, the optimal location of receiving stations and processing

facilities in order to conform best to regional requirements."

The U.N. has also asked for studies of the organization and cost of regional centers, and has requested a study of U.N. involvement in a hypothetical international space segment and in training programs which might support these actions. It may be doubted whether this means that a U.N. system will emerge, but whether or not some international regime will develop is not yet clear. I personally think that it is just as likely that we shall have new international institutions and services in this area as did happen in the case of communication satellites.

The abiding requirement for the future, of course, is continuity in the service. Landsat-C gives reasonable assurance of this, probably through the rest of the decade. I have no doubt that there will be continuity and that there will be additional national programs capable of obtaining and providing space data, although these programs may not all be quite as accessible as the U.S. space segment is to the international community.

Future Remote-Sensing Programs

Russell L. Schweickart^a

Rather than making any attempt at a comprehensive view of the future activities, I would prefer to highlight what I consider are some of the more significant elements of remote-sensing programs, looking toward the future. It is certainly appropriate that, after our rather intensive review of the present status of remote sensing, we take at least a glimpse toward the future in this very promising area.

I would like to add a personal note. Having flown around the Earth for 10 days back in 1969 on Apollo 9, I can assure you that it is a very impressive, personal experience from the subjective point of view. It also stimulates rather wild flights of imagination, along the technical lines in thinking, about what can be observed and what could be done from that vantage point. After spending all that time looking at the Earth, two points come through very loud and clear. One is that, at the altitude and velocity that we were traveling, the whole Earth seems a very small place; the other is that the tremendous vantage point that we had provides a unique capability for capturing both detail and a total global view. What is needed, in spite of the rather wide latitude of human eyes, is better observation instruments which can extend the human eye beyond its capability and an ability to retain that view so that other people can use it. I guess that is what we are all about in this business.

As physical scientists and, especially, as people involved in remote sensing, we can look at the Earth as a kind of solar reflector: radiance in, radiance out. However, we can also look at it in a slightly different way. If we know the radiance in from the Sun, we can easily view the radiance out as information out. In fact, we can view the reflected radiance from the Earth, either altered reflection or emission from the Earth, as an information crop which is growing as a "fuzzy ball" around the Earth. And, in some ways, the job that we have here is developing those kinds of agricultural tools which can harvest as they go around the globe and cut out swaths of this crop in a sampling manner, so that we can better understand the nature of the surface in which these crops are growing. Now be careful not to take my

agricultural analogy too far. But much information is represented by this radiance reading of the Earth. And that is what we are sampling with these instruments we are developing. Our challenge is to learn to harvest and utilize this crop intelligently. How do we get there from here? I would like to discuss that in terms of a near, an intermediate, and a long-range view.

In looking at the near term I tend to think of user needs and what we are doing about them. One of the most pressing needs felt now, in looking toward the near future, is timely flow of data from the satellite to the user. This is expressed not only by those who are involved in the direct use of, and experimentation with, the data, but also by those in legislative and governmental positions who are very much aware of the utilization of these new tools for the greatest benefit.

Historically, it is easy to understand why we are where we are in this business, in that our primary challenge a few years ago was to understand the inherent, or potential, value in the data itself. Rapid service and transmission of Earth resources data are not, in most cases, necessary for that kind of understanding. However, as we move into an evaluation of operational or quasi-operational use of these data, the need for a timely flow of critical information is very real, especially if we are to have legitimate evaluations of the benefits, costs, and related effectiveness of Earth resources data as an information source. A recent study completed for NASA gave some indications of the timeliness requirements of users. In this study, which considered data needs of all Federal agencies, 36 percent of the identified user tasks indicated the need for the data within one week or less from the time they were acquired by the sensor. For an additional 29 percent, data were needed between a week and a month from the time of sensing. Data for the remaining 35 percent of needs were acceptable at intervals greater than a month. I think that these are also representative of the needs in the general user community.

The question, then, is, "What are we in the government, who are responsible for the technology,

^aNASA Headquarters, Washington, D.C.

PRECEDING PAGE BLANK NOT FILMED

doing to meet this need, or, at least, to work toward meeting it and addressing it?" Let me mention a few items. At the Goddard Space Flight Center, we are installing, for experimental purposes, a "quick look" capability, which will enable us to generate uncorrected imagery from Landsat within approximately 5 hours of receipt of data at Goddard. This type of quick-look data has proven to be very useful in the Canadian experiments. In addition, there are other modifications being made to the NASA data processing facility at the Goddard Space Flight Center. Phase 1 of that modification has already been completed. That was to increase the capability to process Landsat scenes onto computer-compatible tape form; we went from an original capability of 10 scenes per day up to 48. In 1976, we expect to have the capability, after phase 2 completion, to process 200 scenes a day, on both film and computer-compatible tape. In addition, the hardware which is going into this modification at Goddard will enable the handling of greatly increased data flow from satellites — not only Landsat satellites, but also the heat capacity mapping mission, Nimbus G, which will be launched in 1978, and the synchronous meteorological satellites, which are now in orbit and will continue with us for some time. This type of integrated capability for production of images from the whole class of Earth-viewing satellites will give us a capability to integrate multiple data from many sources to solve most resource management problems.

But if we look at moving toward a 24- to 48-hour flow of data from satellite to user, we recognize an additional need to speed the shipment of the data from the sensor to the processor to the distributor. To do this, the Department of the Interior and NASA are studying the possible use of commercial communication satellites to ship raw data from Alaska to California, as it is received from the satellite, directly to Goddard Space Flight Center and then, in turn, send processed high-density digital data from Goddard to the Earth Resources Observation Systems (EROS) Data Center at Sioux Falls. In conjunction with this improved communication speed, the EROS Data Center at Sioux Falls is considering the installation of an all-digital processing capability. When that is in place, hopefully in the near future, but certainly by the Landsat-C time frame, we expect to provide more timely delivery of a greater variety of higher quality data products to the user community.

Another need that I feel must be addressed in the near future is the need to understand, in a very solid way, the real utility of remote-sensing data in the operational context. It is difficult to measure the value

of data in research, but in terms of the best way to carry out an operational function, we have to get very serious about hard measurements of the performance and the ability of a space system, or any other new technology, to replace existing capabilities which are already in place. So, as we move into the near future, I would expect to see continued emphasis, not only by NASA, but also by other elements of the government, on application verification testing, as opposed to the general trend which we saw earlier in the program, toward research on the information itself. This kind of testing involves the integration of space-derived data with many other data sources in order to adequately determine whether or not we have here a "better mousetrap."

As we move toward the midterm future, toward more and more specialized applications, as we get more experience, I think we will find that, although Landsat has a tremendously broad value across the total spectrum of needs, certain needs will begin to emerge as more specialized requirements which will influence our research and development program. They generally include such variables as frequency of coverage, or repeat cycle; the spectral coverage, what particular bands are best, what ranges of the spectrum; the spectral resolution, how narrow those bands are, how focused they are to particular things that we are looking at on the ground; spatial resolution, how small an element we have to see in order to meet the needs of some user; the dynamic range — in some cases the dynamic range of these sensors needs to be very broad, in other cases, fairly narrow; the time of day of coverage, because very low Sun angles are nice for the geologists and very high Sun angles are good for the agriculturists. We compromised in Landsat; I am sure we will see divergence in the future. Geometric accuracy — being able to register data taken at different times and also from different satellites — is going to become a greater need as we move into the integration of many sources of data and take greater advantage of multitemporal or repeated observations. The whole idea of change detection is very attractive in that it eliminates the necessity of looking at every piece of data. If they can look at only those things which have changed, many of the users will have their data handling problems greatly reduced.

In considering these kinds of needs in the intermediate term, we see Landsat-C coming along, which will give us some additional capability in the thermal region with the addition of a fifth band. In addition, we will be able to look forward to modest increases in resolution, twice that of Landsat-1 and Landsat-2, through modification of the return beam

vidicon cameras on Landsat-C. This has certain applications in urban land use planning, cartography, and also in the ability to measure with greater accuracy smaller fields in the agricultural area. We expect to see Landsat-C getting into orbit in late 1977.

Also in the midterm, we will be looking at additional applications of thermal information from space. To that end, we hope to be able to look at soil moisture quantitatively. This is a very critical parameter, especially in most agricultural applications, but also in certain other fields of endeavor. Measurements of surface conditions using thermal inertia characteristics will be made from a satellite we call the heat capacity mapping mission. The heat capacity mapping mission will put out temperature maps of the Earth every 4 days on a 4-day repeat cycle, or thermal inertia characteristics on about an 8-day cycle. The resolution, of course, is not as good as that of Landsat. When we get that kind of frequency of coverage, we have to pay for it. So we are talking about a 500-meter resolution and approximately a 600-mile swath width, but we are anticipating that many applications will come out of this mission.

Also in this same time frame, we hope to have a satellite in orbit called Nimbus G, which will have onboard the coastal zone color scanner. This will make many people who deal with the marine area happy because the coastal zone color scanner will specialize in the water area. The scanner will have quite a few spectral bands on it. The lower four will be very narrow bands, to look at particular aspects of water-suspended elements like chlorophyll, sediment, and other organic materials. A thick band, very much like the Landsat band 6, will provide general information. And then there will also be a band in the thermal infrared to give temperature measurements. This will give us much more information for use in coastal zone management and other marine studies.

One of the exciting research areas is the microwave area which will allow people to look through clouds. By the end of this decade we will be flying certain satellites, using microwave instruments for sea surface and sea condition measurements, and sea ice monitoring. We will also be continuing research using microwave techniques in agricultural and other applications.

For the long term, many of the specialized needs I mentioned will become even more specialized as we move into the 1980's and as more users become familiar with this type of information. Of course, in the 1980's, we expect to see the Space Shuttle and Spacelab capability emerge. Most of our programs are oriented toward taking advantage of that new capability. It is a very exciting possibility when you think about being

able to inspect, replace, modify, and even recover satellites from orbit to make them more useful, cost effective, and, perhaps, specialized. In general, we are looking toward a spacecraft which we are calling Landsat-D now (it has been referred to in earlier studies as EOS). Landsat-D will be compatible both with conventional launch vehicles and with the Space Shuttle. It would be basically a modular spacecraft, so that it would have a greater capability than any single design. One of the principal sensor packages that we are looking at is called the thematic mapper. Recently a working group met to discuss the various trade-offs in the many applications of the thematic mapper we anticipate. Generally, agriculture was seen as the main element, and to some extent the recommendations reflect that feeling. The thematic mapper will have six spectral bands, five of them in the visible and near-infrared, and one in the thermal infrared. These are not final, but the recommendations from the working group were that the lowest band be tuned to blue and blue-green areas of the spectrum, primarily for hydrologic studies, although many applications in land use will also benefit from that band. The next four bands will center on particular areas of interest to agriculture, especially concerning food and fiber development. The thermal-infrared band will also give us additional information on vegetation density and enable us to discriminate between certain types of land cover. The design recommendation of the thematic mapper is to achieve 30- to 40-meter spatial resolution, although the thermal channel will be approximately 120 meters. For geometric resolution, we decided to try for half a picture element registration capability from one scene to the next, or from one scene taken at one time to the next task.

The whole Space Shuttle Program in the 1980's and beyond will reflect the tremendous change in our method of doing business brought about by this new capability. I certainly have some particular interest in the Shuttle; it is also my next chance to fly. To state it simply, the Shuttle will be launched vertically and will be able to land horizontally. It will provide a very mild environment for both the passengers and the payload in getting into and back out of space. This will ease certain design problems regarding the payloads. It will be able to carry a very large payload (approximately 60 000 pounds) into near-equatorial orbit and somewhat less than that into a polar orbit. We will be able to launch the Shuttle from both the East Coast at Cape Kennedy, for low-inclination orbits, and from Vandenberg Air Force Base on the West Coast, for the polar orbits. It will carry upper stages, which will enable the placement of certain satellites into higher orbits than the Shuttle is

capable of reaching directly. At a later time, these upper stages will be automated to the point where we can also retrieve satellites from very high orbits and bring them back to the Shuttle and back to Earth. As I mentioned earlier, a very exciting capability is represented by the rendezvous with satellites already in place for their repair, replacement, refurbishment, and even return to Earth.

Not least of the capabilities brought about by the Space Shuttle will be in cooperation with the European Space Agency, a consortium of European nations who are putting together a module called the Spacelab. The Spacelab comes in two parts, an instrumented pallet and a pressurized space laboratory for manned operations. The Spacelab capability will enable us to take two to five passengers or payload specialists into orbit to conduct experiments in the space environment and bring them back to Earth. This opens up tremendous opportunities in research and development, and in operational capability in the use of the Shuttle. Our large payload enables any one particular discipline that flies in the Shuttle to pay only its share of the total mission cost. Therefore, we expect to see a much greater utilization of relatively special-purpose, short-term experiments such as research into signature extension and other experiments in remote sensing, instrument development engineering, or special high-priority data

collection missions. Certainly the Space Shuttle will give us much greater and more cost-effective means of utilizing space for operational purposes in the future.

In closing, let me just make a couple of additional remarks on an operational capability related to remote sensing from space. It would be presumptuous of me to speculate on what that system would look like or when it might come about. However, I think it would be useful to mention what I consider to be very strong prerequisites which will affect all of us as we move toward that capability. Mainly, we will have to convince the decisionmakers and the user community of the economic effectiveness of this new capability to do necessary jobs here on Earth. Without hard and rigorous effort along those lines, we will not get there from here. I think this problem is one which has already begun to affect all of us in this business, as you can see from recent efforts at cost/benefit studies and other analyses of that kind. I think that, as we pursue the operational or quasi-operational applications of these data, we are going to have to pay as much attention to this aspect of the program as we do the area of technical performance.

I look toward a day when the view that I had from space several years ago becomes an operational tool in dealing with the global challenges which face us all on this home planet of ours.

AGRICULTURE

Summary

Richard Baldwin^a

Secretary Weinberger took a very positive view about our ability to feed, clothe, and house ourselves and some of the rest of the world. I share that view. Today, the world has 350 000 more people than it had when the conference began 4 days ago. If they are to eat well, we have to produce upward of 350 000 more tons of food per year than we had to produce as of 4 days ago. This upward pressure of population puts the food providers between a rock and a hard place.

In the past, we have always been able to meet our demands. There has always been more land. We have had a fertilizer revolution. Hybrid corn was developed, which greatly increased our capacity to produce food. Agricultural chemicals came along to help us manage this production. Cheap energy became available to operate tractors and all of the wonderful new farm equipment. Agronomic technology developed very rapidly in the past few years. And, more recently, the so-called miracle seeds that all of you have heard about have increased the production capacity not only in this country, but also in many other parts of the world.

Now we must continue the growth in production to keep up with the population. A significant help in managing our resources would be more and better information on ranges and rangelands, forests and timberlands, soils, and crops. There have been more concerns over agricultural resources in the last 2 years than the public has had in the last 2 or 3 decades. This is a healthy situation because we need to have this attention directed to our productive capacity.

One of the concerns at our summer study program on applications of space technology was agriculture. At this symposium also, we have addressed this important area of everyone's lives. How can we use these data from remote-sensing devices in space to create information

that helps us produce, manage, and distribute our necessary food supplies in a better, more efficient manner? It can be done, and it must be done.

Our speakers have identified several levels of information which can be extracted from remotely sensed data and applications to which the information may be put. These were as follows.

Techniques for estimating and predicting the available forage for range animal consumption were demonstrated in five of our major rangeland areas. The sandhills region in Nebraska presents a unique area to utilize Landsat data (A-1, vol. I-A) in estimating vegetative biomass for managing this 20 000 square statute miles (52 000 square kilometers) of rangeland (fig. 1). The uniform soils of this area minimize the variances in radiance caused by soils variability. Correlation coefficients of 0.9 for radiances to biomass were achieved using band 5 of the multispectral scanner and automatic data processing methods.



Figure 1.— Nebraska rangeland on a uniform soils base.

^aCargill, Incorporated, Minneapolis, Minnesota.

11 338-074

A highly productive but little studied area, the coastal prairies, was addressed (A-2, vol. I-A) to differentiate the rangelands from the unproductive salt marsh areas. Accuracies of 89 to 96 percent for the areal extent were achieved. Estimation of production of vegetative matter was not addressed for this region.

The ability to monitor annual grasslands was demonstrated (A-3, vol. I-A) in the intermountain region of California. By use of Landsat data, the investigator was able to correlate plant growth stages and forage production to climatic and other environmental factors. Image characteristics and spectral reflectance data were then related to forage production, range condition, range site, and changing growth conditions.

Within the Great Plains corridor, which extends from the southernmost tip of Texas to the Canadian border, Landsat data from test sites were analyzed (A-4, vol. I-A) to predict the available forage for livestock consumption. The correlations were good within the identified areas.

Landsat data appear to be adequate to map these areas and, from the information obtained, to determine

with a high degree of confidence the available forage. This information could be of great value to range management agencies, such as the Bureau of Land Management, the Forest Service, and regional agencies, in determining how many animal units can be put on a specific piece of rangeland and when to take them off. For this use, the data need to be available promptly (within 5 to 10 days after collection) and frequently (at 9-day intervals). An operational system needs to be devised and implemented to test this demonstrated technology for cost effectiveness and feasibility for full-scale ongoing operations.

Forest lands also cover large areas, and efficient management is essential to capture their greatest productive capacity, whether public forest or private areas. Six speakers discussing forest-related applications demonstrated various ways of converting data from Landsat and high-altitude sensors to useful information.

One speaker (A-8, vol. I-A) showed how the data were used to update maps of clear-cut forest areas (fig. 2), to map cutting rates, and to better manage forest areas. These analyses indicated that the previous year's

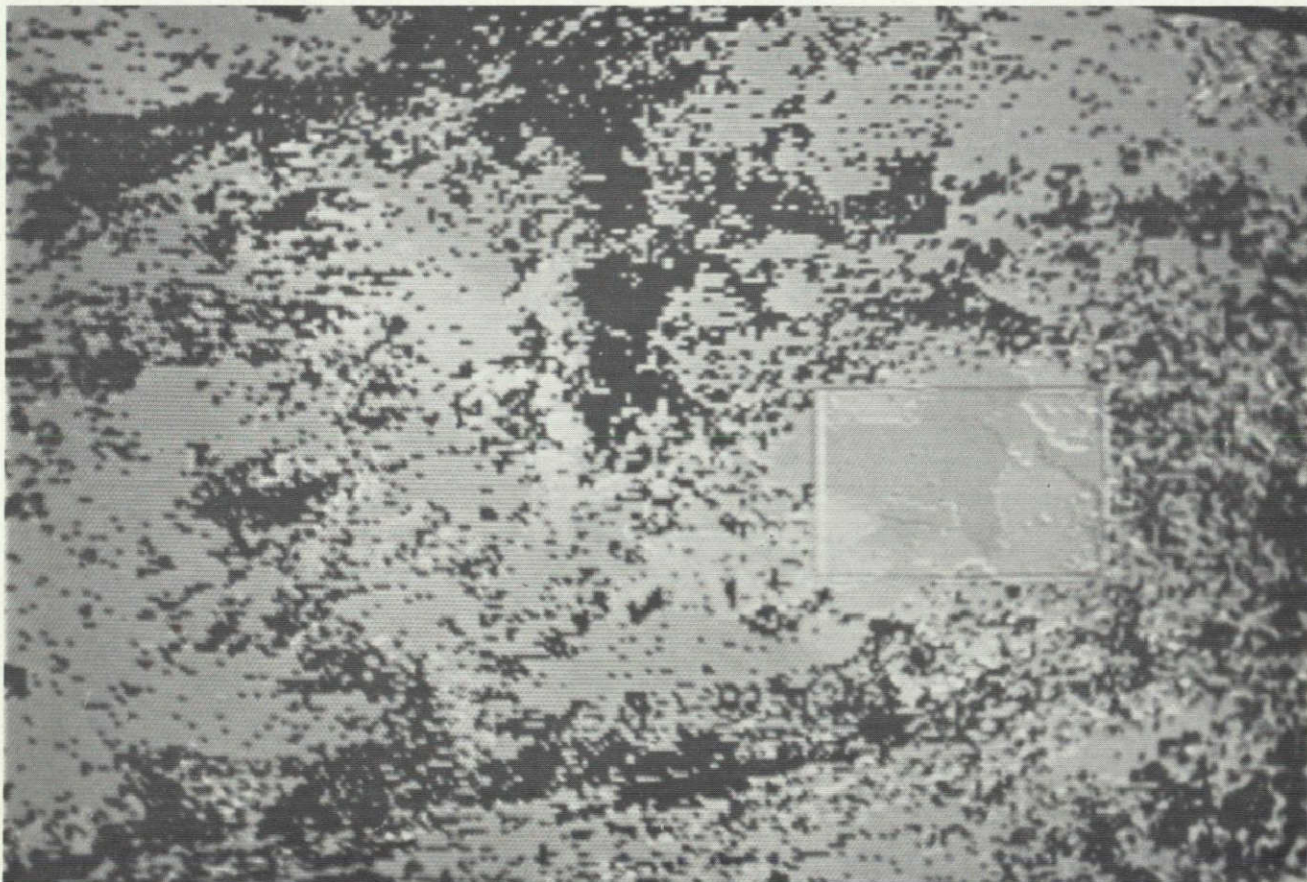

Figure 2.— Clear-cut forest areas visible in Landsat digital data.

clear-cut areas had been overestimated by 12.9 percent and clear-cut areas of 1 year and older had been underestimated by 3.6 percent.

A representative of one of the large paper and timber companies described how, on a limited budget, his company was developing simple techniques (fig. 3) using remotely sensed data to help pinpoint available timber supplies in terms of location, type, quantity, and quality (A-10, vol. I-A). Another speaker demonstrated how Landsat data can be used to classify timber with up to 95 percent accuracy for types of trees and up to 80 percent accuracy in defining the conditions of the forest stand (A-11, vol. I-A).

Landsat data were converted to information depicting the available fuel for sustaining fires in the Santa Monica Mountains in southern California (A-12, vol. I-A). Here, 1.25 million acres were mapped for a cost of less than 3 cents per acre. This information was an input to an operational model which is a great help in reducing and controlling forest fires and helping to preserve the forest.

The results of a study of gypsy moth infestation (A-13, vol. I-A) demonstrated that Landsat data can be used to discriminate between defoliated and healthy vegetation in Pennsylvania and that digital-processing methods can be used to map the extent and degree of defoliation. Signature extension was successful in this study when signatures from one Landsat image were transferred to another scene in Pennsylvania imaged on the same day. This seems to suggest applicability for statewide approaches.

The third area that was discussed in our session related to soils. Soils mapping on a broad synoptic view and down to soil association level was demonstrated in the papers presented.

Soils mapping application was used to satisfy state tax legislation in South Dakota (A-6, vol. I-A). Soils association maps (fig. 4) were developed for the state which were keyed to productive capacities and land values. Cost for producing such low-intensity surveys was about 2 cents per hectare.

At the Laboratory for Applications of Remote Sensing at Purdue, digital data were analyzed to identify a specific soil association which had gone undetected in previous soil surveys. This was a continuity of a narrow meandering strip of prairie soil (fig. 5) running east and west for about 40 miles across central Indiana (A-7, vol. I-A). It is in an area of predominantly timber soils and is believed to be a buried valley of the glacial age.

These examples demonstrate that first-echelon soil mapping can be done from satellite data at very low costs per unit area. Of course, supporting classes of soils must be mapped in the conventional manner.

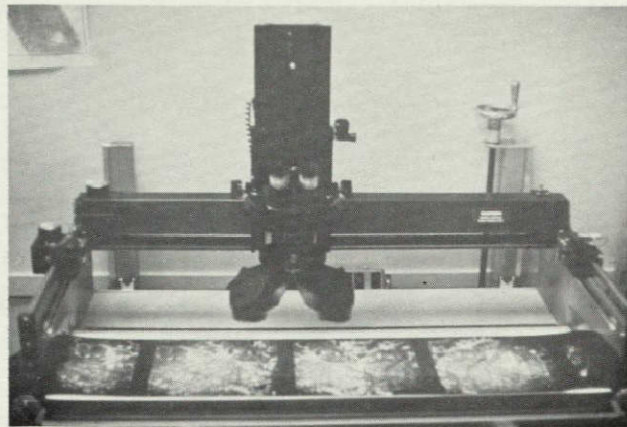

Figure 3.— Machine used to map forest areas and forest types from remotely sensed data.

The fourth area to which remotely sensed data were addressed is that of crops. The ability to identify crops and inventory acreages, using data processing techniques on Landsat imagery, was demonstrated in one test area (fig. 6) which was composed of small grains (wheat, barley, et cetera, of which wheat constituted 95 percent), sod, and fallow lands (A-16, vol. I-A). Correct identification of small grains was 98 to 99 percent, sod was 96 to 97 percent, and fallow land was 91 percent.

This gives encouragement to a broader use of Landsat data (when combined with information on soils, weather, and previous crop yields) to supplement estimates of crop production in this country and probably in several other parts of the world. The final speaker in the crops section (A-19, vol. I-A) discussed the usefulness and the need for such crop estimates and such cropping information on a worldwide basis in order to improve the orderly marketing of feed and grain supplies, and to provide early warning signals for distress so that corrective action in various parts of the world can be taken.

One paper (A-14, vol. I-A) addressed the use of a 24-channel multispectral scanner system on aircraft to identify plant species. The test site was a planting spot of three types of pine. The multispectral data, automatically processed, gave excellent identification in all cases.

Skylab data were used to delineate possible avenues of travel of citrus pests between Mexico and the United States, and vice versa (A-15, vol. I-A). Also identified through Skylab S190B data were various crops and frost damage.

Finally, a speaker (A-18, vol. I-A) described the use of remotely sensed data to manage various crops, especially cotton, in an effort to get an early determination of



Figure 4.— Soils map of South Dakota developed from Landsat mosaic.

plant stress, disease, weed or insect infestation, and faulty irrigation. With such information on a timely basis, corrective action can be taken soon enough to actually improve the yields. It was stressed that such applications, to be useful, must be cost effective and very timely.

The agricultural panel discussed the agricultural applications to crops, rangelands, forestry, and soil studies with 68 people participating for nearly 3 hours. Obviously, the interest is high in using remote-sensing data to generate useful information in all four areas. It was generally agreed that the technology does exist to get the data in large quantities from satellite observation, and the capability to massage these data into all sorts of information-type forms is available in various optional computer systems. The work to date has been primarily in research and development. There are many needs that we should be able to meet right now, if specific operational systems can be designed or developed that

will meet the identifiable user requirements for information in a timely fashion where costs are realistic.

Now the situation calls for further development of complete systems on an operational basis tailored to meet specific applications. Most users will want information, rather than a large pile of unprocessed data. The challenge is to find ways to convert the type of data available from many of these Skylab and Landsat sensors to useful information. We do have the ability to do it. It can be a valuable tool in the ongoing process of production and distribution of our food and fibers.

In the few minutes since I started talking, another thousand people have been added to this Earth. We must provide for them food, fiber, and housing. So let me close with a thought expressed by Jonathan Swift several centuries ago: No man has a more worthy goal than he who can help to produce two blades of grass where only one grew before.

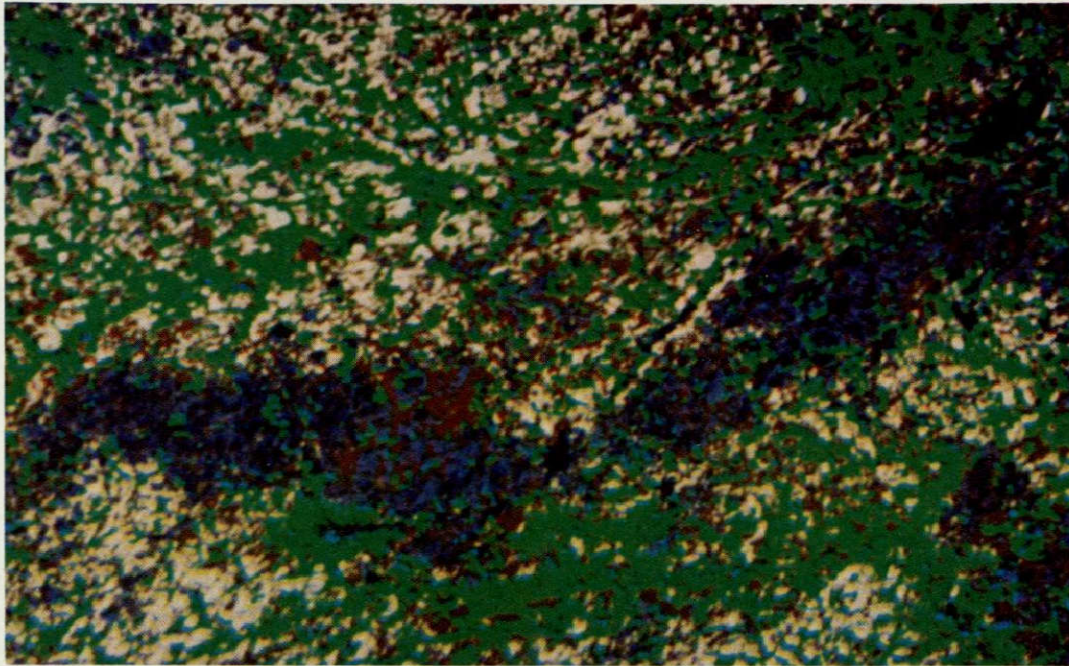

Figure 5.— Soil type pattern detected by digital remote-sensing data but overlooked by conventional surveys.



Figure 6.— Test area for determining how much land was planted in small grains.

Agricultural Applications of Remote Sensing: A True-Life Adventure*

Earle S. Schaller^a

We have been talking about the potential applications of remote sensing for some 20 years. I would like to present some of what we have done with a potential user, to change potential applications into real applications.

In June 1973, General Electric (GE) undertook an 18-month study with a major U.S. agricultural firm. The study had two objectives. First was to transfer the technology and techniques of remote sensing to that firm's personnel practices and operations. This was a training activity. Second was to conduct some pilot studies in the application of remote sensing in ranch management and operations as well as in large-scale agricultural inventories.

The study area was centered in the San Joaquin Valley of California (fig. 1). This is where this organization's ranching headquarters is located. The study itself was divided into two phases. The first was a learning phase. Members of the GE project staff went to the ranch for a major portion of both the 1973 and 1974 growing seasons. Of course, those of us that went were technologists versed in remote sensing; we were not agriculturalists. I still cannot raise tomatoes in a 40-foot square in my backyard. But we did go as technologists with a background in remote sensing, preaching the gospel of remote sensing, and I must confess that we all felt that we had solutions for every problem. We were a solution looking for problems to solve.

Until the time this study began, there were no remote-sensing activities on the ranch. The ranch (fig. 2) is located on a large dry lake, although not all of that land is owned by this particular firm. The farming here is very large scale, and there is a definite economy of scale. All of the activities, the practices, and the equipment are designed to accommodate this scale. Ranching here is done in all seasons. We get an even better perspective from an aircraft (fig. 3). Note the cotton on the right;

each field this size is 1 square mile. There are four fields across and three deep that belong to this particular operation. That is 12 square miles of cotton. That was the largest contiguous planting of cotton in the world in 1973. It is an intensive operation with very low labor input. Most of the operation is highly automated.

We arrived to teach remote sensing, and at the same time we, of course, expected to learn a great deal from them about the operations. They did not have a remote-sensing program. The ranch manager would fly around the ranch once or twice a year for a visual inspection. Let me point out, however, that this is a very successful operation. It is one of the largest in the world. The success derives primarily from the fact that these people have an ideal climate. It is hot and dry all year. They have excellent soil, which they care for tenderly. They also have an organization of dedicated, experienced people.

My hopes for some of our success were somewhat bashed when we found that the ranch manager walked the ranch twice a year — or drove the ranch twice a year — for the sole purpose of making a yield forecast. His last yield forecast is made some 8 weeks before harvest. He has been forecasting yields on a field-by-field basis for 10 years. His record of success is repeatedly less than 2 percent off and he does it by himself. So you can see the kind of thing we were facing going out as technologists to teach remote sensing.

We brought with us all of our Landsat data and all of our photographs of the ranch, and we spent many, many weeks working side by side with the ranch personnel. I must confess, we came with the intention of trying to elevate them to a perspective from some 500 miles high; they brought us down to Earth very quickly. So we began to learn, communicate, and understand.

The major activities during this first phase were training and collecting ground-truth data, mostly

*Based on papers A-16 and A-17 (vol. I-A).

^aGeneral Electric Company, Beltsville, Maryland.

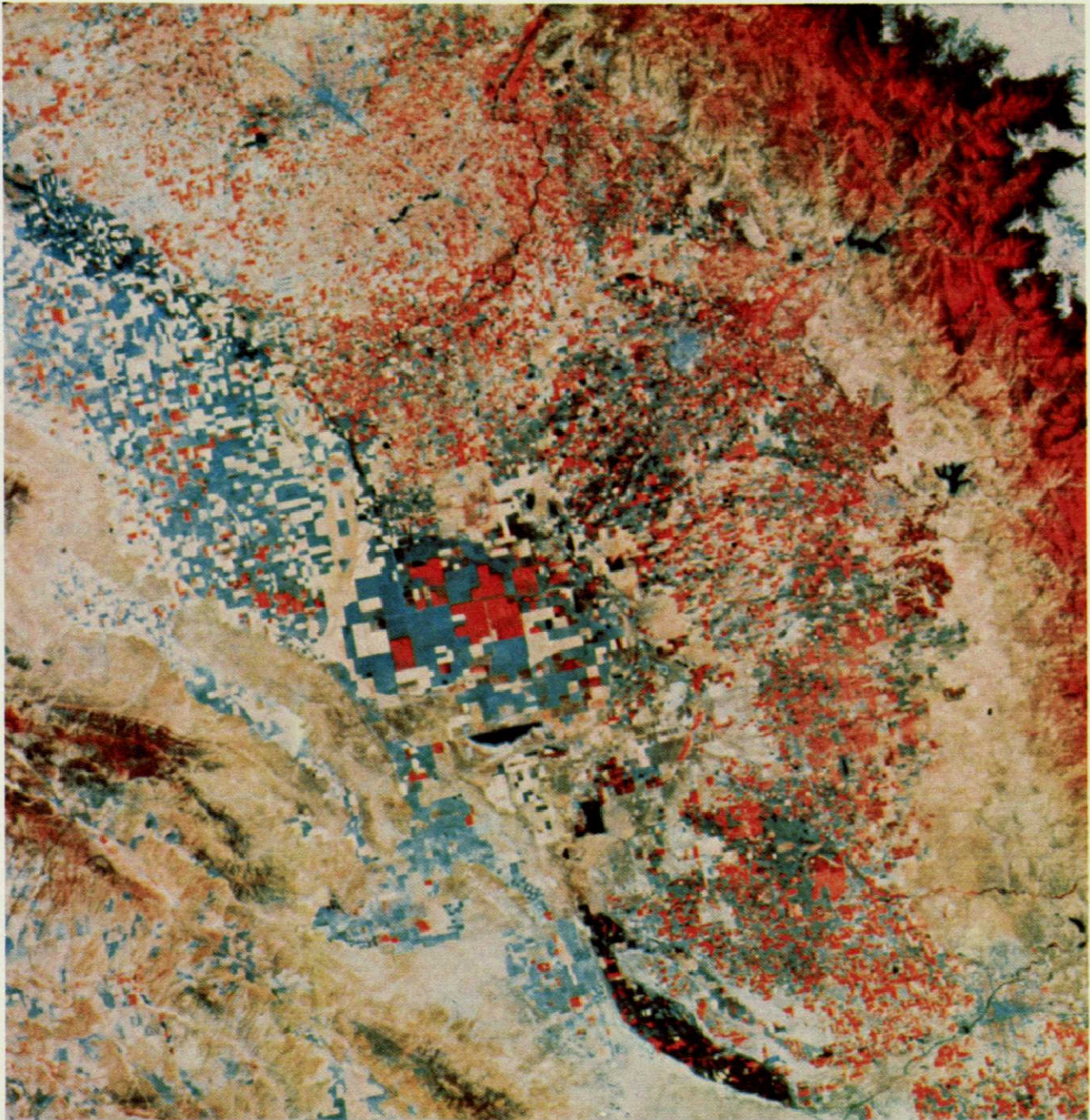

Figure 1.— Color-infrared image of San Joaquin Valley, California, where the test ranch has headquarters.

photographic. The ranch people keep excellent records, both accurate and comprehensive, going back many years, which we had full access to.

We also started a very experimental aircraft program. We were experimenting together and working together. Our first effort used a 35-millimeter hand-held camera hung out the window of an airplane. We tried to give this a quasi-operational flavor by processing the data at night

and then reviewing it with the ranch people the next morning. We took pictures as you see in figure 4. This was very crude, but we did identify some dry spots, some mite damage, and some insect damage. We also experimented with some regular color films. This was the kind of data that began to make sense to them.

They really had very good control over what they had on their ranch by virtue of organization, and because



Figure 2.— Enlarged view of the ranch itself.

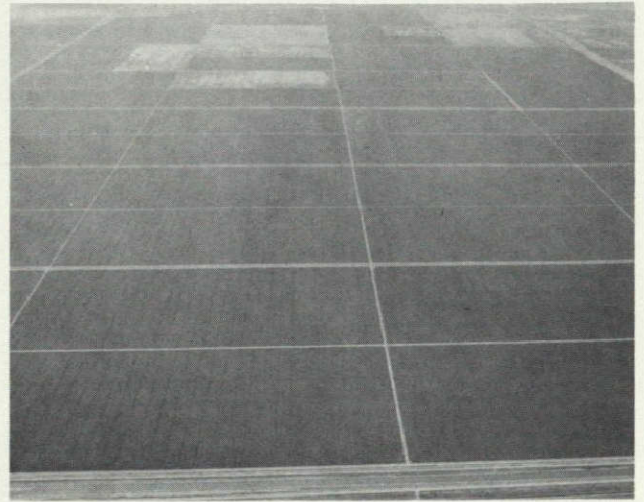

Figure 3.— Low-altitude aerial view of part of the ranching operation.

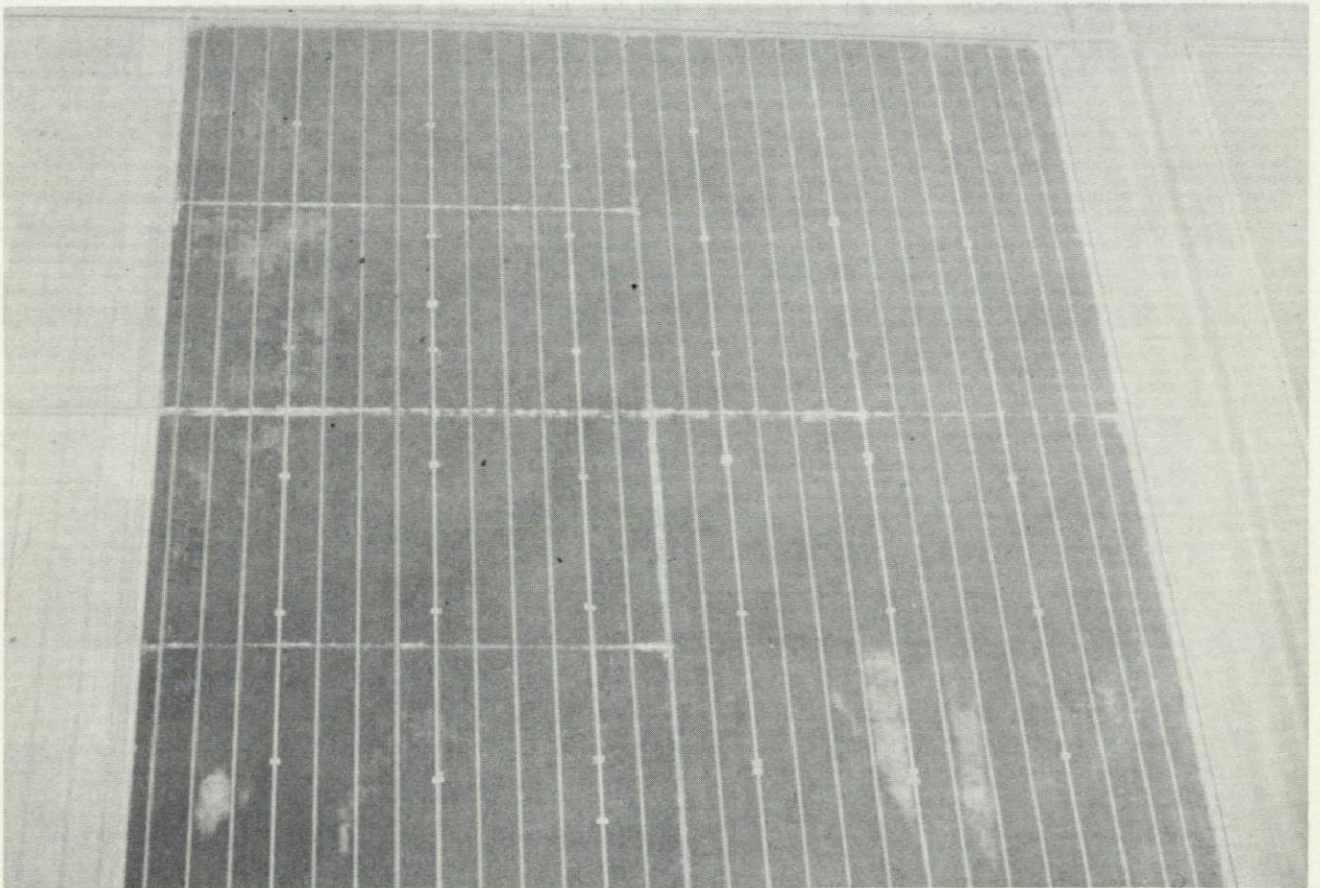

Figure 4.— Fields of seed alfalfa taken from an airplane with a hand-held 35-millimeter camera.

they spent many, many hours inspecting the ranch and had car-to-car communications. So some of the mite and insect damage information, even though we felt that we could detect it early, was not as greatly valued as was information about the soil and soil conditions. The soil is where they make their living; they are very much concerned about that. We did get enough information from this kind of an activity to go ahead with a second phase in the second year with a much more sophisticated method.

We instrumented one of the corporate aircraft with a 9-inch camera. Using 2043 aerofilm, we established flight lines which covered the entire 50 000-acre ranch, plus another of their ranches of about 35 000 acres, some 60 miles to the south. We covered these every 9 days on a schedule which was synchronized to the Landsat coverage every 18 days. We flew the data, had it processed, and had the 9- by 9-inch color transparency film back, usually within 12 hours. These were reviewed in great detail with the ranch people. We also had all of this material cut, filed, indexed, sorted, and stored. We

also developed a set of interpretation keys for them, which they could use and are using.

In figure 5, you will see some of the imagery that was collected. This figure indicated the intensity of the farming operation. There is no such thing as fallow ground. They work on a 24-month cycle. You are looking at safflower which is drying out, and cotton which is growing. The wheat in this scene has been harvested; it is being disked under in preparation for another crop. The ground is either in production, in preparation, in preirrigation for another crop, or in some other stage; fields just do not sit fallow in this sort of operation.

Figure 6 indicates the usefulness of this kind of information. Here they could evaluate some various ripening patterns, and various field experiments that are underway. There are also some test fields here. In this particular 1-square-mile field (figure 7), the right-hand half of the field has a history of cotton after wheat, the left-hand half of the field has a history of cotton after cotton. This is the first time they recorded any kind of

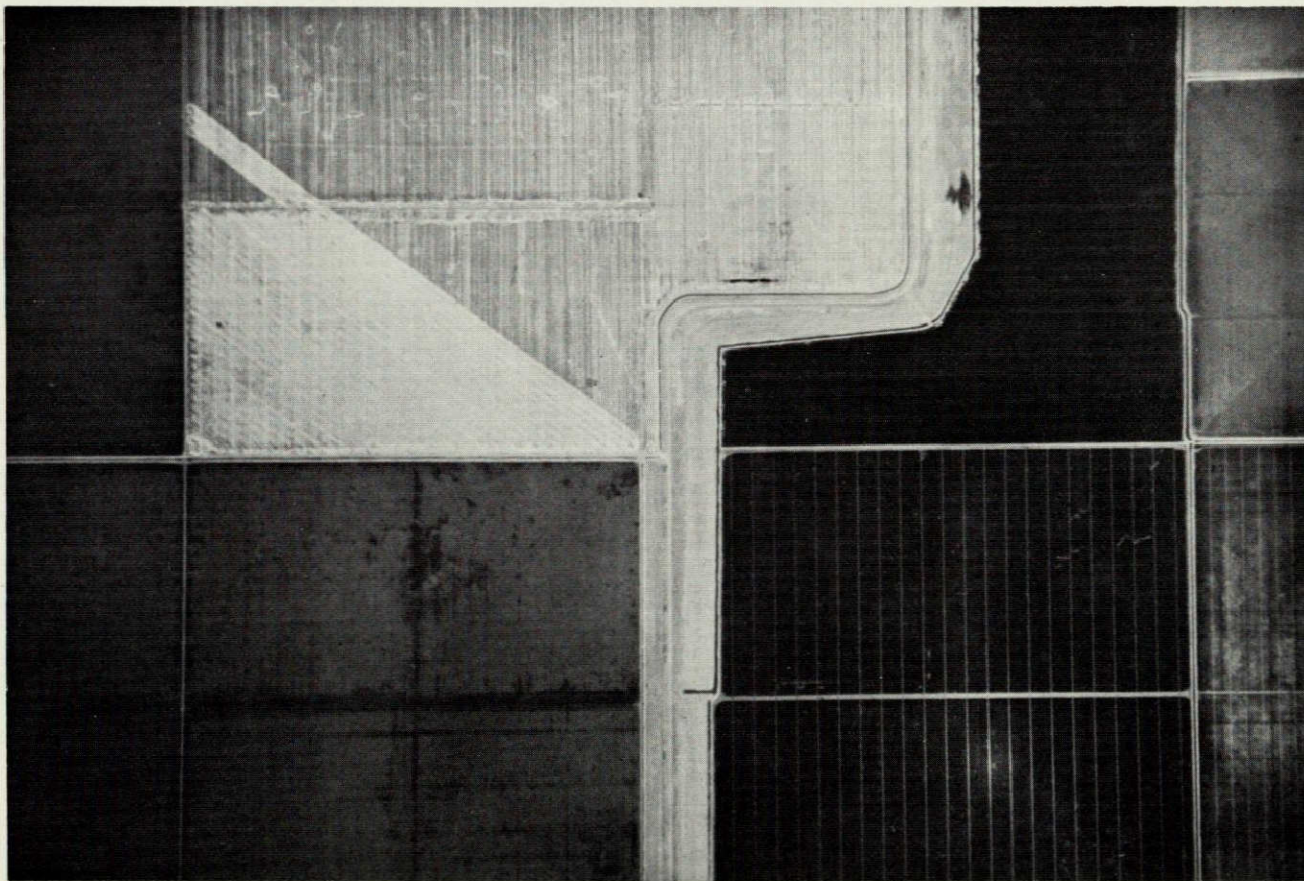

Figure 5.— An example of some of the imagery collected with the aircraft-mounted camera.



Figure 6.— Ripening patterns are visible in this imagery.

qualitative indicators which would allow them to evaluate these kinds of practices. I firmly believe that much of the early detection material is important to them, and I think they felt it was, too, but perhaps not worth the cost involved.

The information derived from these aircraft data, having a somewhat intangible value, was worthwhile. As a result the ranch managers have extended this program into the 1975 season. They have since implemented their own operational program totally under their control. They are flying a modified schedule which allows them to cover some critical crop periods and allows for special-purpose flights.

This photographic information and some of the soil data are used to evaluate new land going into cultivation. They have a 5-year sliding scale land improvement program which they have been running for some years. They also found that this information could be put into an accelerated operations program allowing them to move into milo, safflower, or cotton much more quickly. Any land capable of supporting these crops allows them a great number of options, and is a significant mark of their ability to do real-time dynamic management.

One of the principal interests of this organization was the application of data to large-scale inventories. For this reason, we conducted a pilot study, or rather a first test, to see how well we could do some large-scale inventory using the Landsat data. I am not going to go into great detail on the machine techniques. They have been presented many times. Figure 8 is a digital display, as shown on the GE Image 100, of the ranch area. All of

the red area is cotton. We did an inventory for the first time in September using these known areas as training sites and established a number of additional training areas. We developed six signatures to test signature extendability. We also did a number of things with raw data, such as ratioing data and resolution variations. In figure 9, you can see the results of the first alarm. We did get very high accuracies, comparing the alarmed area against the actual test area.

We then extended the signatures over the San Joaquin Valley, or a large part of it. Figure 10 shows the ranch to the south, which is located on a dry lake. Each of the six signatures were applied to this area so that in effect we did six inventories at the same time.

In the total survey, we covered 4.8 million acres of ground to find 650 000 acres of cotton. Three of the six signatures yielded the results within 90 percent accuracies. One of the signatures yielded a result within 97.2 percent. The requirements of the inventory, insofar as this particular corporation is concerned, are twofold: one, the earliest possible inventory of acres planted, and two, an accuracy of 95 percent or better. The managers are not interested in yield on their own ranch, but rather with acres planted within a given area. Coupled with their own knowledge of production rates in various areas, acreage gives them all the data they need to make the necessary management decisions.

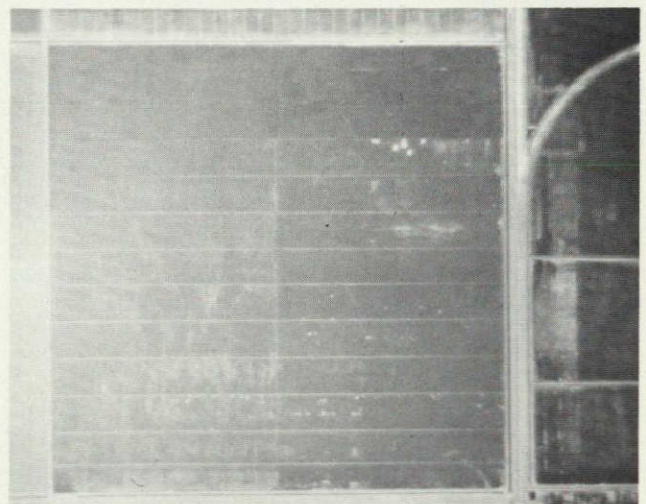

Figure 7.— This field shows obvious differences between the left side (which has been planted in cotton after cotton) and the right side (which has been planted in cotton after wheat).



Figure 8.— Digital display of the ranch area. Cotton shows up in red.

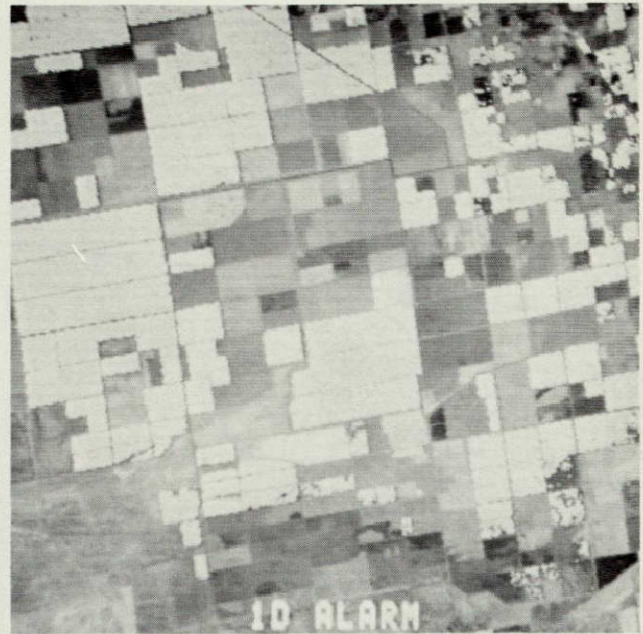

Figure 9.— Cotton signatures show a high degree of accuracy.

In that single day's inventory, we were limited to using a date which was 6 weeks before harvest. September 11 was the earliest date at which we were able to accumulate that kind of accuracy, 97 percent.

On an experimental basis in a small sample, we did do some multitemporal classifications (fig. 11), using the same area. There was no capability to register digital tape, but this system is accurate enough over small sections. This area is 9 by 9 miles on the side. The same area is shown in May, August, and both dates together. These are bands 4, 5, and 7 displayed here. The blue-green area is cotton; the area in red is safflower. The other major crop is seed alfalfa. In May, it is almost impossible to distinguish seed safflower and seed alfalfa. In August, the cotton is matured and is all in red, whereas the safflower is dried. The spots you see are small areas where weeds have occurred and have been burned out. These are very small areas, but you can see them quite clearly. The seed alfalfa is shown in the darker color; it is starting to dry out and turn. There are some areas, though, where the less vigorous cotton will look almost identical to the seed alfalfa. It was very difficult to distinguish.

In figure 12, we have bands 5 and 7 from May and 5 and 7 from August superimposed. Cotton is readily identified here by the red. There is no classification done at all; this is just a visual indicator. The safflower is displayed in purple. It shows up very clearly from the

seed alfalfa. This illustrates a very simple classification. We did this to show these people the long-term benefits of an agricultural inventory using multitemporal data.



Figure 10.— Cotton signatures extended over the San Joaquin Valley.

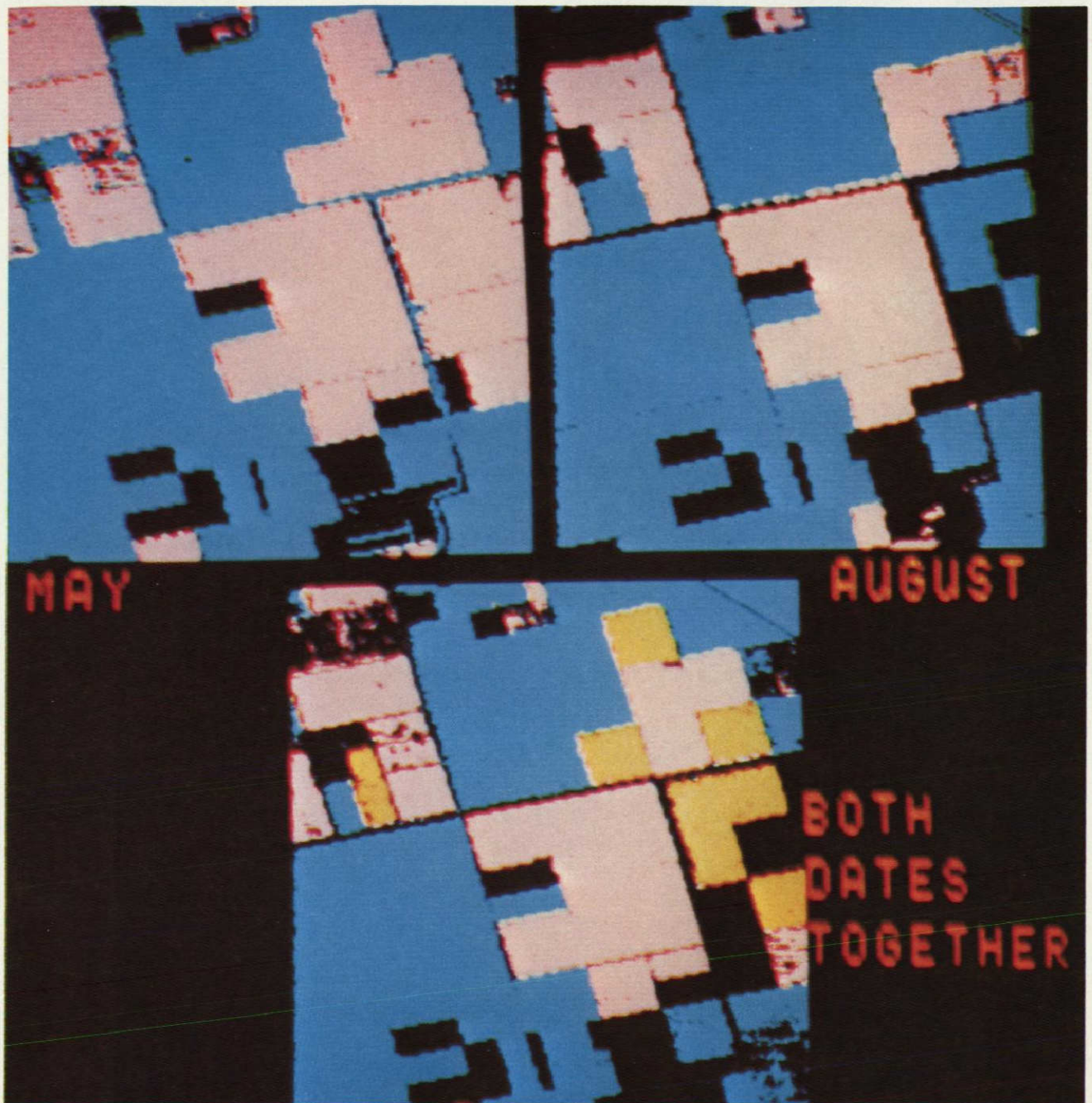

Figure 11.— Crop classification through comparing the same area on different dates.

We did not do a definitive study of inventory, certainly. We tried some techniques and we were quite surprised with the very good results that we obtained. There was some concern that perhaps it was because of the very large test sites, the homogenous crop, the day, or other things.

At the same time we were working in California, David Dietrich, Dwight Egbert, and Ron Fries of GE

were conducting an in-house study to evaluate the agricultural inventory capabilities of Landsat data. Digital tapes and ground truth were provided by the U.S. Department of Agriculture (USDA) for study areas in Williams County, North Dakota, and Melfort, Saskatchewan, Canada. Whereas in the California test areas, crops were grown in sector (or square mile) size fields (259 hectares), the Williams County and Melfort

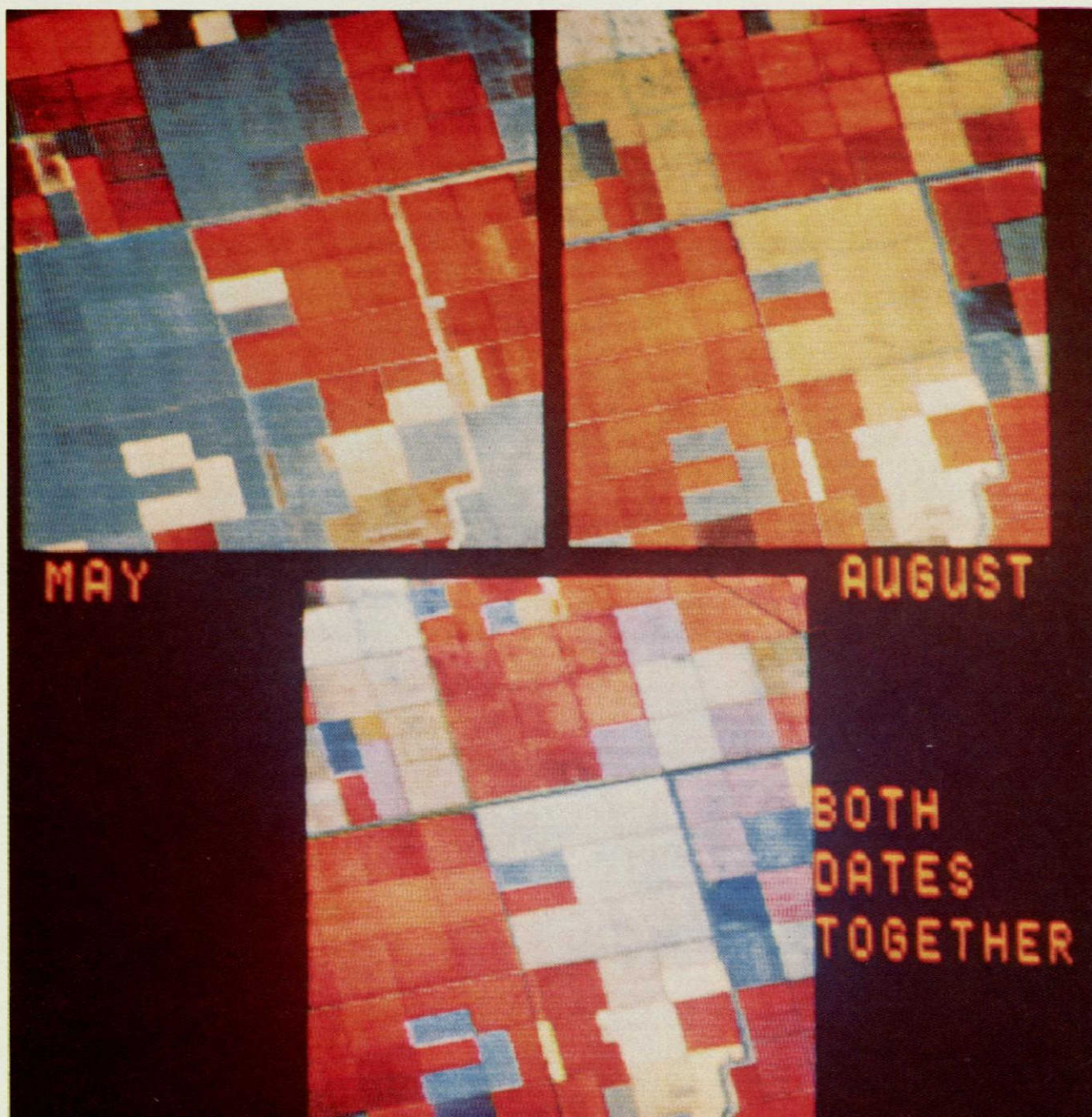

Figure 12.— Landsat bands 5 and 7 from two dates superimposed to make crop identification easier.

sites were representative of more typical agricultural practices, with field sizes ranging from 0.4 to 130 hectares.

Three crop classification categories were defined in the Williams County study area: small grains (wheat, barley, and oats), fallow, and sod (sod and grass). Within the 3- by 13-kilometer study area, training and test sites were selected for each crop category to facilitate

interactive multispectral signature extraction. The size of each training and test set was approximately 2.4 percent of the entire study area. Using training and testing techniques with interactive signature manipulation, very accurate crop identification and acreage results were obtained (table I).

The approach derived in the Williams County study was then applied in conducting a similar crop survey in

**REPRODUCIBILITY OF THE
ORIGINAL PAGE IS POOR**

Melfort, Saskatchewan (fig. 13). The study area size was also 3 by 13 kilometers. The crop categories were small grains, fallow, and rape. Classification was accomplished using the test and training criteria, and using only multispectral scanner bands 5 and 7. Final acreage accuracy results for Melfort were 99.3, 98.2, and 91.7 percent for small grains, fallows, and rape, respectively.

Since only one day of Landsat data was used for each study, more specific differentiation of the small grains and sod categories was not attempted. Multitemporal techniques would undoubtedly allow for more precise crop identification; for example, spectrally differentiating between oats and wheat.

Perhaps the real importance of these studies is the demonstration that highly accurate results can be achieved when a Landsat classification scheme extracts statistics for a sampling area rather than attempting to survey field by field.

Let me conclude with a couple of thoughts. One, we dealt with a major agricultural firm that has now become the user to some extent. A lot of communication was done. I think we have to make sure in all our dealings of this nature that we pose the material we have to offer as a complement and an adjunct, and certainly not as

something that is going to replace what these people are doing. That will never work. But it did find value; it is being used; it is being extended. I think the very first step was getting them to use the aircraft. I think as the data are collected, they will find more and more value from each photograph they use.

A second point I might make is the fact that although we certainly do not have all the answers, we do have some of the answers to some of the problems. It is foolish to wait until we have all the answers before we start trying to solve some of the problems.

Lastly, I would be remiss if I did not tell you where we stood with this particular organization using Landsat data. All of the material is sitting on the shelf. It is sitting there primarily because of the inability to get data in a time frame that these people require. I have talked to a great number of farmers in my dealings, and I find that they deal in today and in tomorrow and very few of them have the luxury to deal in yesterday. They do not write history. They are looking for today's data. This organization can and will become a major user of Landsat and other forms of remote sensing as soon as the data can be provided in the operational time frame which they require.

TABLE I.— WILLIAMS COUNTY TEST FIELD OMISSION^a

Crop	Number of test pixels	Number of correct pixels	Percent correct
Small grains	213	212	99.5
Fallow	216	188	87.0
Sod	210	196	93.3

^aAfter trimming.

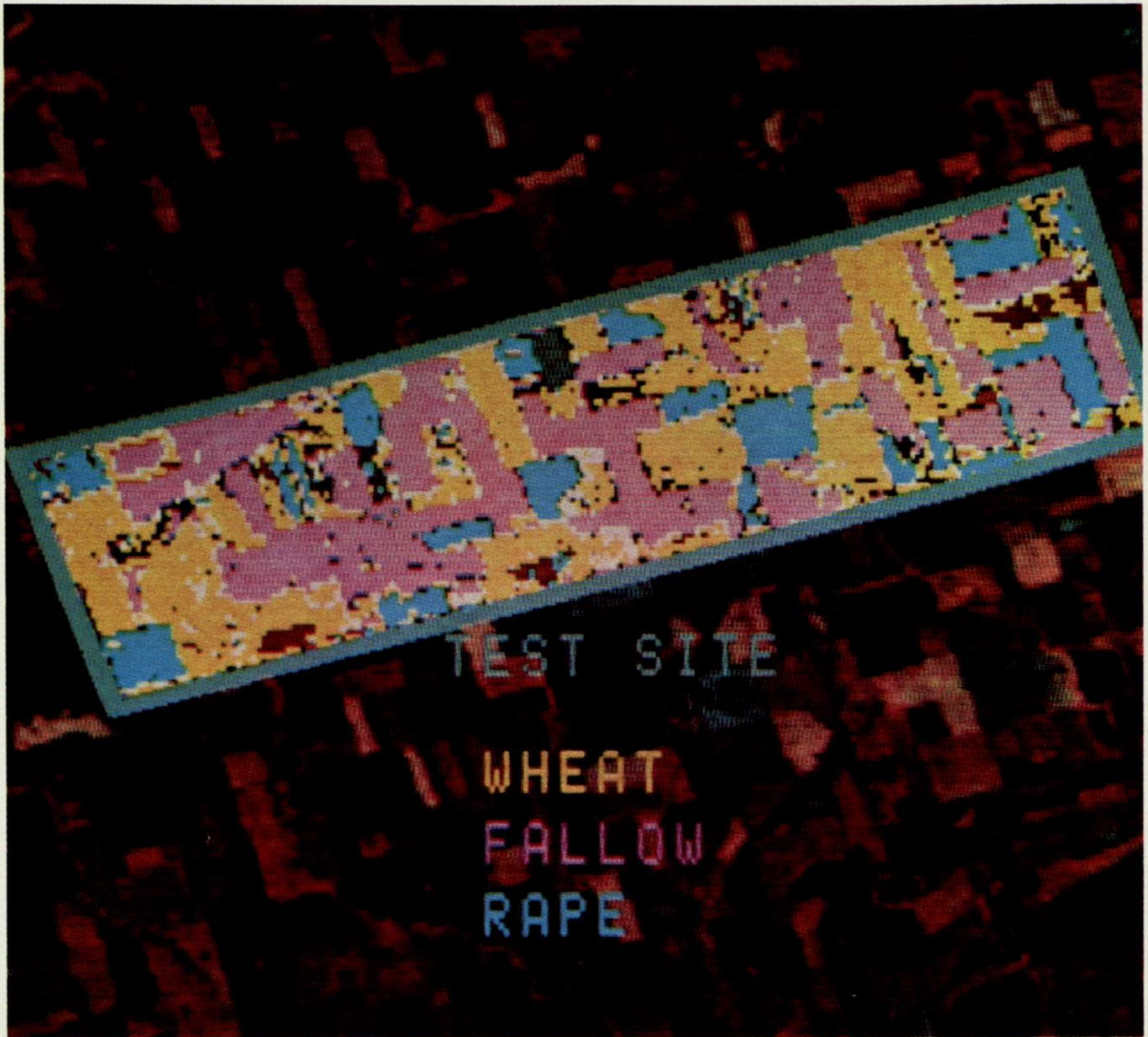

Figure 13.- Digital-tape classification of crops in Canada.

REPRODUCIBILITY OF THE
ORIGINAL PAGE IS POOR

GEOLOGY

Summary

Floyd F. Sabins, Jr.^a

INTRODUCTION

One purpose of this paper is to identify and describe trends in geologic application of remote sensing as exemplified by the 28 geologic presentations at the 1975 NASA Earth Resources Survey Symposium. These trends are as follows.

1. Increased applications of orbital imagery in fields such as engineering and environmental geology — some specific applications include recognition of active earthquake faults, site location for nuclear powerplants, and recognition of landslide hazards
2. Utilization of remote sensing by industry, especially oil and gas companies
3. Application of digital image processing to mineral exploration

The mineral exploration discussion points out some requirements for future satellites to make them more useful for geologists. Another purpose is to correct a popular misconception about the role of remote sensing, particularly Landsat, in oil exploration.

ENGINEERING AND ENVIRONMENTAL GEOLOGY APPLICATIONS

Soon after Landsat imagery became available, geologists recognized numerous lineaments, many of which proved to be either mapped or unmapped faults. A good example of a previously unmapped fault discovered on Landsat imagery is described in reference 1. Geologists are now applying the lineament mapping capability to engineering and environmental problems.

Active Earthquake Faults

Active earthquake faults are generally defined as those along which movement has occurred in Holocene time (last 11 000 years). In earthquake-prone southern California, active faults are recognizable on the high-resolution S190B photography of Skylab (G-13, vol. I-B). Figure 1 is a photograph of the Indio Hills in the Coachella Valley with an interpretation map as figure 2. The Mission Creek and Banning Faults are right-lateral, strike-slip faults that merge in the southeastern Indio Hills to become the main San Andreas Fault trace. On the Skylab photograph, both faults are marked by surface scarps and offset drainage, which are criteria of active faults. The vegetation concentrations on the northwest side of the faults result from the barrier effect of the faults on the southeastward flow of ground water. Hence, the water table is nearer the surface on the northwest side of the faults and supports desert vegetation. The epicenter of the 1948 Desert Hot Springs earthquake (magnitude 6.5) is located 2 statute miles north of the Mission Creek Fault trace (fig. 2), although no surface faulting was associated with the earthquake. Along the trace of the merged faults a few miles southeast of the area of figure 1, surface faulting occurred during the Borrego Mountain earthquake of 1968 (ref. 2).

I am personally acquainted with the Coachella Valley from numerous field trips to the area and was impressed by the clarity with which familiar geologic features were imaged by Skylab.

Allen (ref. 3) effectively employs Landsat images to illustrate characteristics of active faults in many seismic regions of the world.

^aChevron Oil Field Research Company, La Habra, California.

PRECEDING PAGE BLANK NOT FILMED

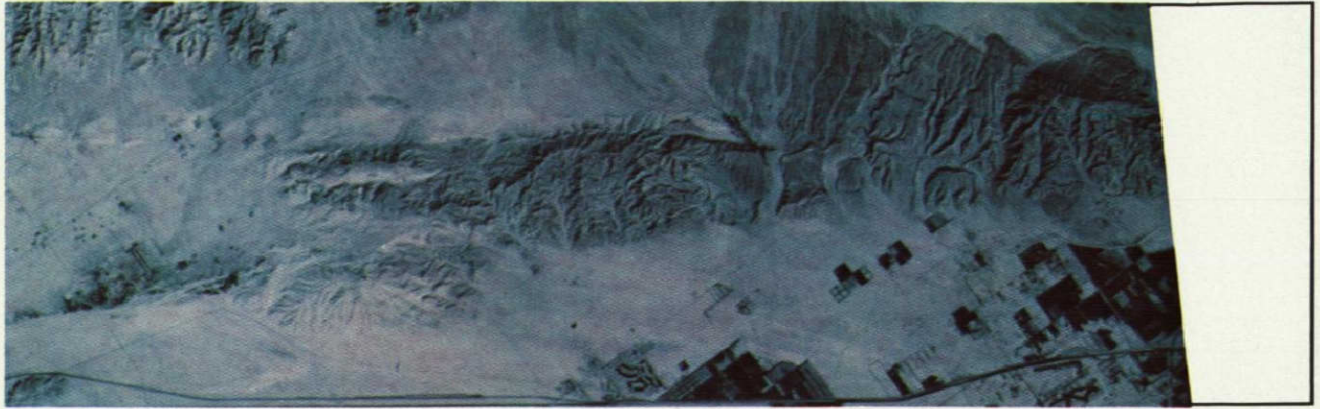

Figure 1.— Enlarged portion of a Skylab natural color photograph of Indio Hills, California, taken with the earth terrain camera (SL4-92-352).

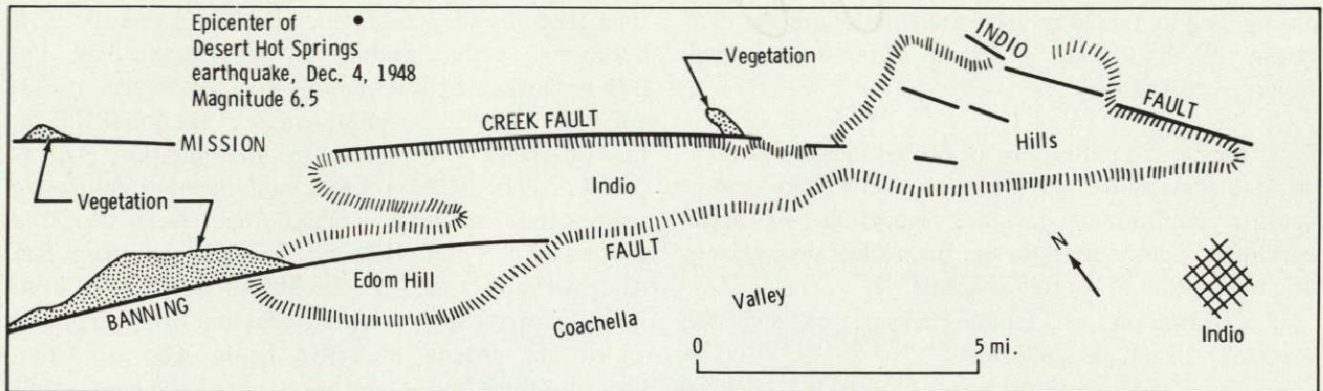

Figure 2.— Map of the area shown in figure 1 including features identified from the photograph. Solid lines indicate prominent linear features along active faults.

Nuclear Powerplant Site Investigations

Landsat lineament studies can reduce the cost of evaluating potential nuclear powerplant sites around the world (G-14, vol. I-B). Proposed sites located on or near major lineaments may be eliminated from further consideration, thus saving the expense of field and geophysical surveys on unsuitable locations.

Landslide Hazards

Regional lineaments in northwestern Arkansas were recognized on radar imagery (G-12, vol. I-B). The lineaments are also apparent on Landsat images, particularly the winter example of figure 3, where partial

snow cover and seasonally low Sun angle (25°) enhance the lineaments. As indicated by arrows, the lineaments consist of alined drainage segments. The western two lineaments coincide in part with mapped faults, but the eastern two were not previously mapped. Figure 4 shows the lineaments together with location of known landslides. Although the landslides themselves are not detectable on Landsat imagery, a large percentage is concentrated along the lineaments. Thus, lineaments are indicators of landslide-prone areas in northwestern Arkansas and point out areas where highway and other civil engineers should proceed with caution.

It is hypothesized that the correlation between lineaments and landslides relates to a common cause. The lineaments probably represent zones of fracturing which also promote deeper weathering and moisture accumulation leading to landslides along steeper slopes.

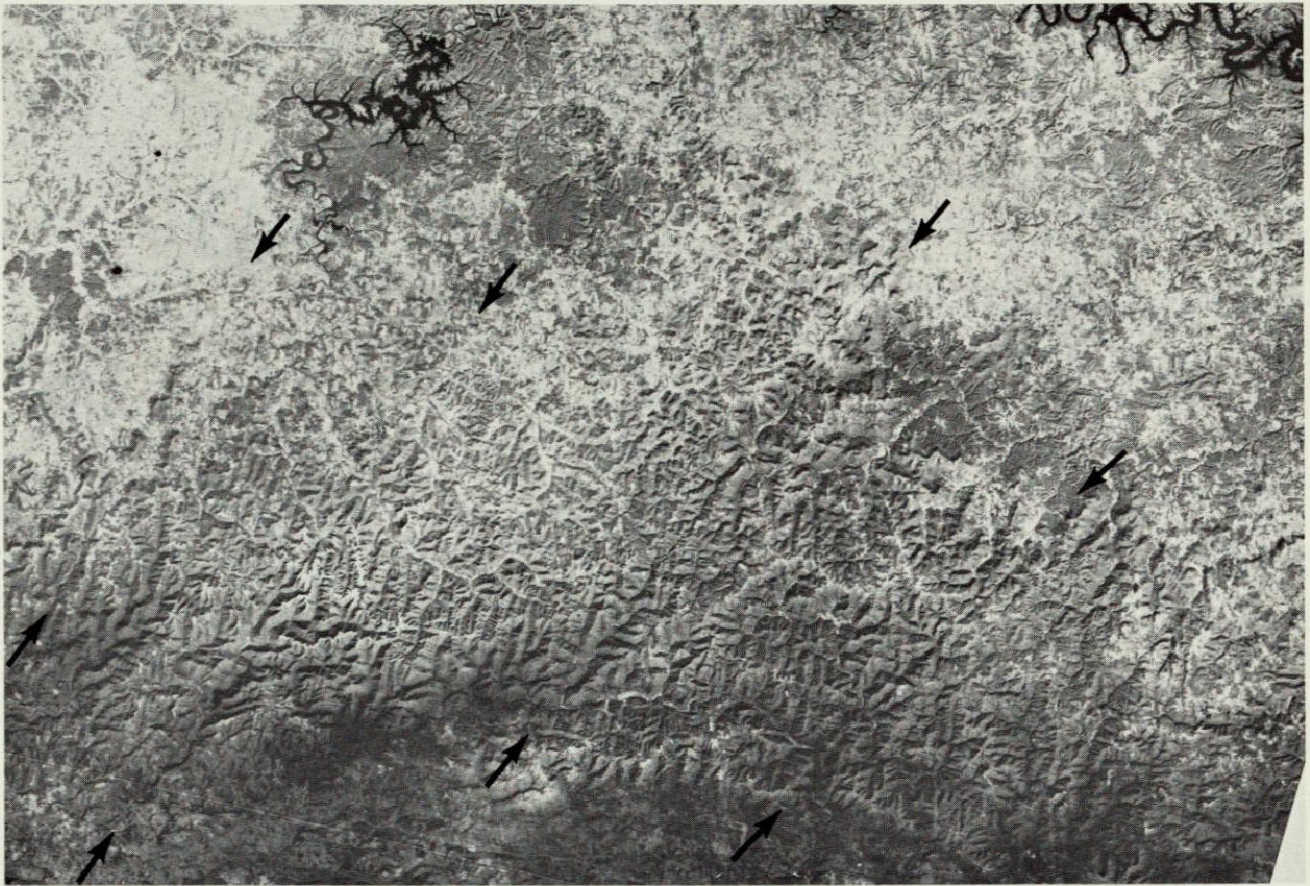

Figure 3.— Landsat image of northwestern Arkansas showing major lineaments marked by arrows (image 1145-16235, band 5, taken December 15, 1972).

INDUSTRY UTILIZATION

With a few exceptions, until 1975 there was little publication or presentation by private industries describing their utilization of remote-sensor imagery. This utilization is extensive; private industry is the largest single user of imagery from the Earth Resources Observation Systems (EROS) Data Center, accounting for 30 percent of total sales volume. (See paper U-2, vol. II-B.) Contrary to popular belief, the lack of industry papers and publications is not wholly due to proprietary restrictions by management. Within their organizations, industry geologists are not rated on the basis of their outside publications. This contrasts with university, government, and some consulting geologists for whom publications are a major part of their occupation. Therefore, geologists in private industry have little incentive to publish their results, aside from the personal satisfaction of contributing to knowledge.

When encouraged, however, industry is responsive to publication invitations as shown in early 1975 at the Remote Sensing Case History Conference at the University of Kansas jointly sponsored by the American Association of Petroleum Geologists, the U.S. Geological Survey, and the University of Kansas. Of the 28 papers, 11 were given by oil and gas company representatives. This trend continued at the NASA symposium in Houston, where three of the papers were given by oil and gas industry personnel and represented privately funded work.

The use of remote-sensor imagery by the Columbia Gas Company in the Haysi gas field of Virginia and Kentucky was reported by Owens and Ryan. The field produces from naturally fractured "tight" reservoir sandstones. Side-looking airborne radar imagery and black-and-white infrared photography were used to locate previously unmapped faults and fracture zones at the surface. Another important discovery was that the

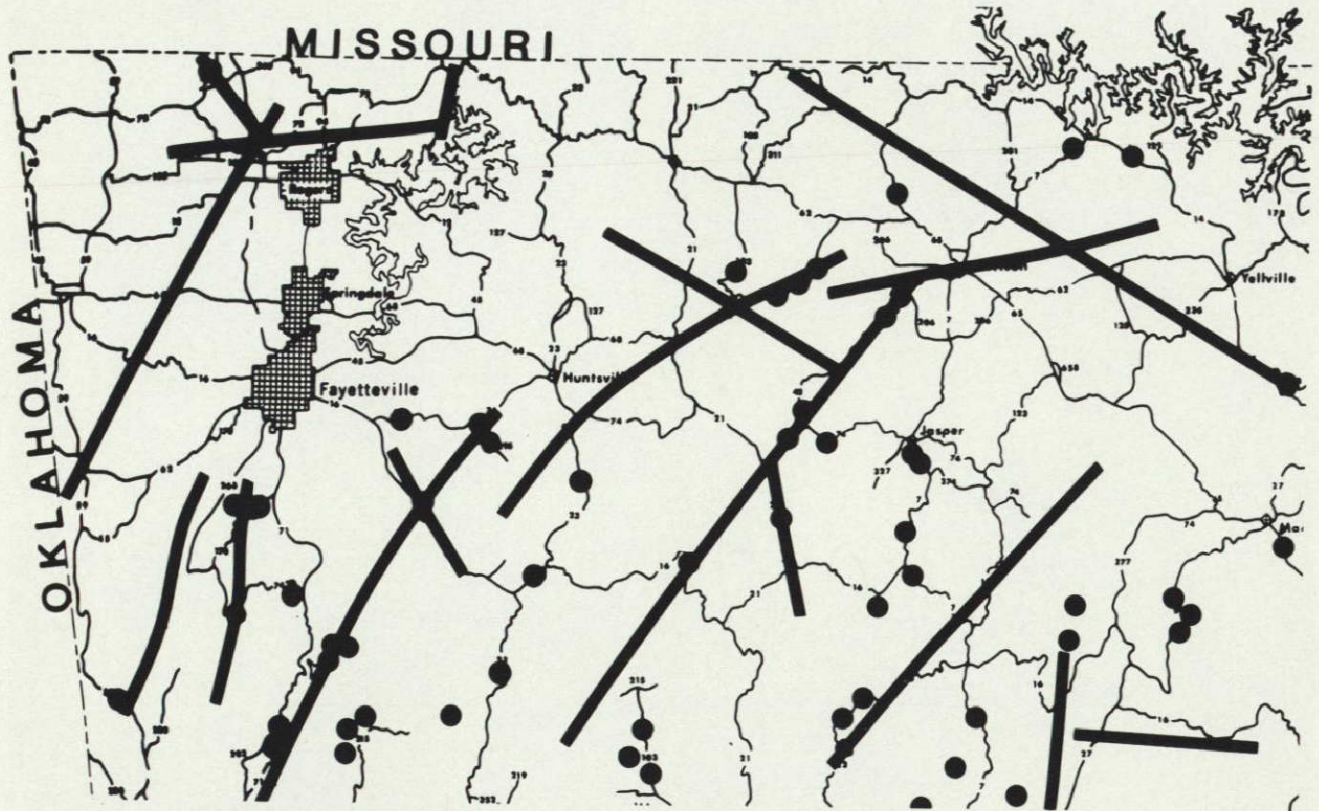

Figure 4.— Correlation between lineaments identified in figure 3 (solid lines) and landslides (dots).

fractures are not vertical, but instead have an average dip of 80° to 81° . Based on this information, 15 wells were drilled to penetrate the intersection of the "tight" reservoir sand and the fracture zones. These wells, located by remote-sensor data, proved twice as productive as the average field well.

The use of side-looking radar imagery by Continental Oil Company in the Eilanden Basin of Irian Jaya was described (G-1, vol. I-B). Both aerial photography and geologic field reconnaissance are difficult in this high-relief jungle terrain with persistent cloud cover. These obstacles were successfully surmounted by a radar survey that provided high quality image strips from which the following significant interpretations were made.

1. Drainage patterns and drainage anomalies that are possibly related to subsurface structure could be identified.

2. Some rock type identifications are possible. Volcanic rocks are identified by their characteristic landforms. Carbonate rock outcrops are recognized by the distinctive karst topography.

3. Depositional features such as alluvial fans and beach ridges have distinctive appearances on the imagery.

4. The Digul-Timor arch was mapped and appears to be a giant closure expressed at the surface by Miocene carbonate outcrops.

5. Amplitude, length, and breadth of folds in the foothills belt are determined from the imagery. Continental geologists infer that the broader, gently folded structures are more likely to persist at depth in the subsurface. These are better drilling prospects than the narrower, more sinuous folds, which probably do not persist at depth but terminate at thrust faults.

From this interpretation, Continental and its partners were influenced to concentrate on folds in the western foothills belt, such as the giant Dusseldorf anticline 25 kilometers long and up to 6 kilometers wide. The radar imagery was the basis for a geologic reconnaissance of the entire concession area and for recognition of specific areas of interest. The next exploration step is to conduct field and geophysical surveys of the more favorable areas. The identification of favorable areas is a major

contribution of remote sensing, for it enables the slower, more costly surface methods to be concentrated in areas of higher potential.

Chevron Overseas Petroleum, Incorporated, acquired its original exploration license in eastern Kenya and completed a photogeologic and field study in 1972 (G-2, vol. I-B). Landsat-1 imagery of the area became available in 1973 and is shown on the black-and-white mosaic in

figure 5. A generalized map (fig. 6) shows the drainage patterns and geologic features interpreted from the imagery. The drainage patterns provide valuable geographic reference in this region of generalized base maps.

A surprising amount of geologic information is present on the Landsat images, despite the low dip and the low relief of this relatively featureless terrain.

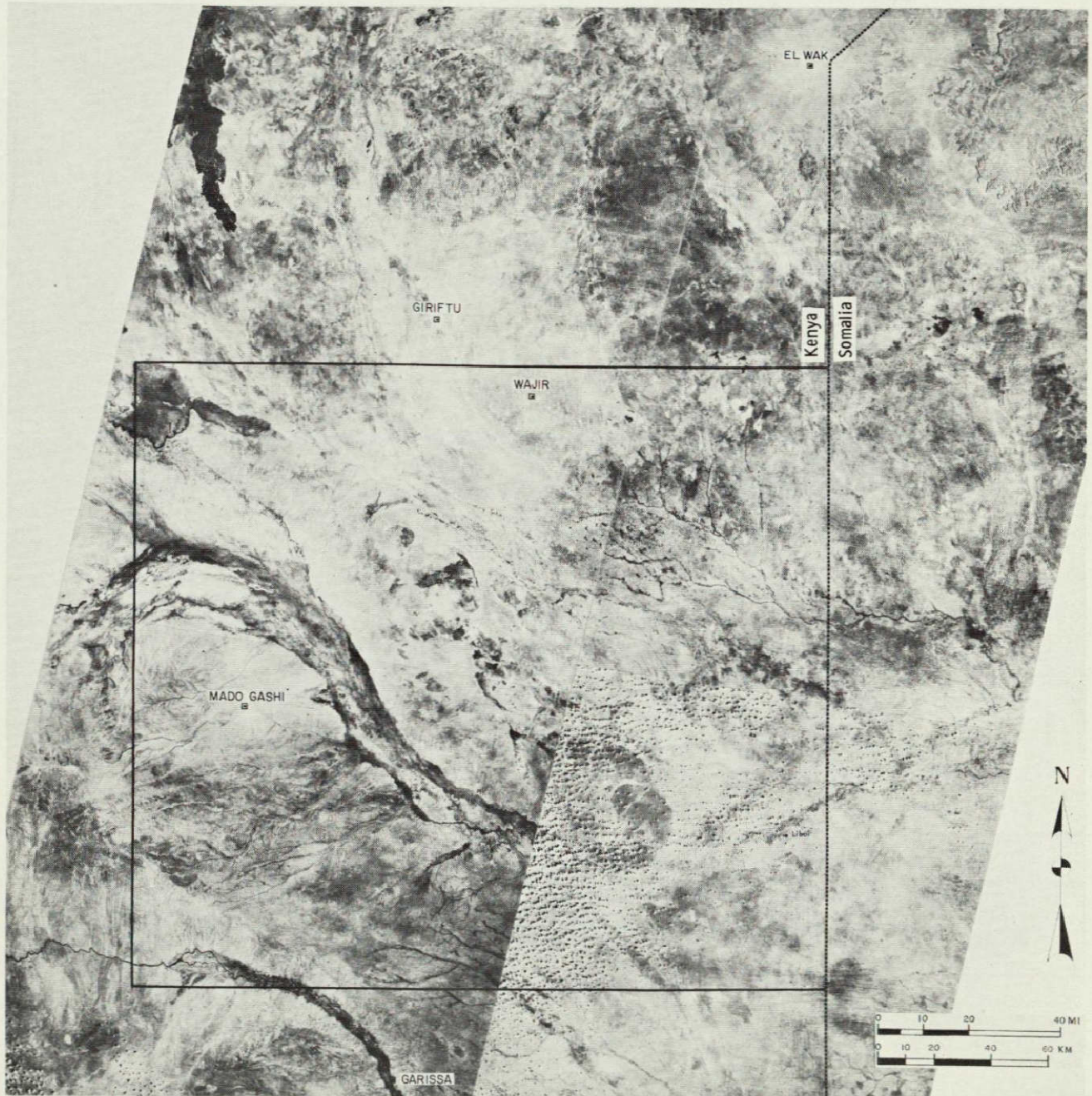

Figure 5.— Mosaic of eastern Kenya, made from Landsat-1, band 7, images, showing the original Chevron license area.

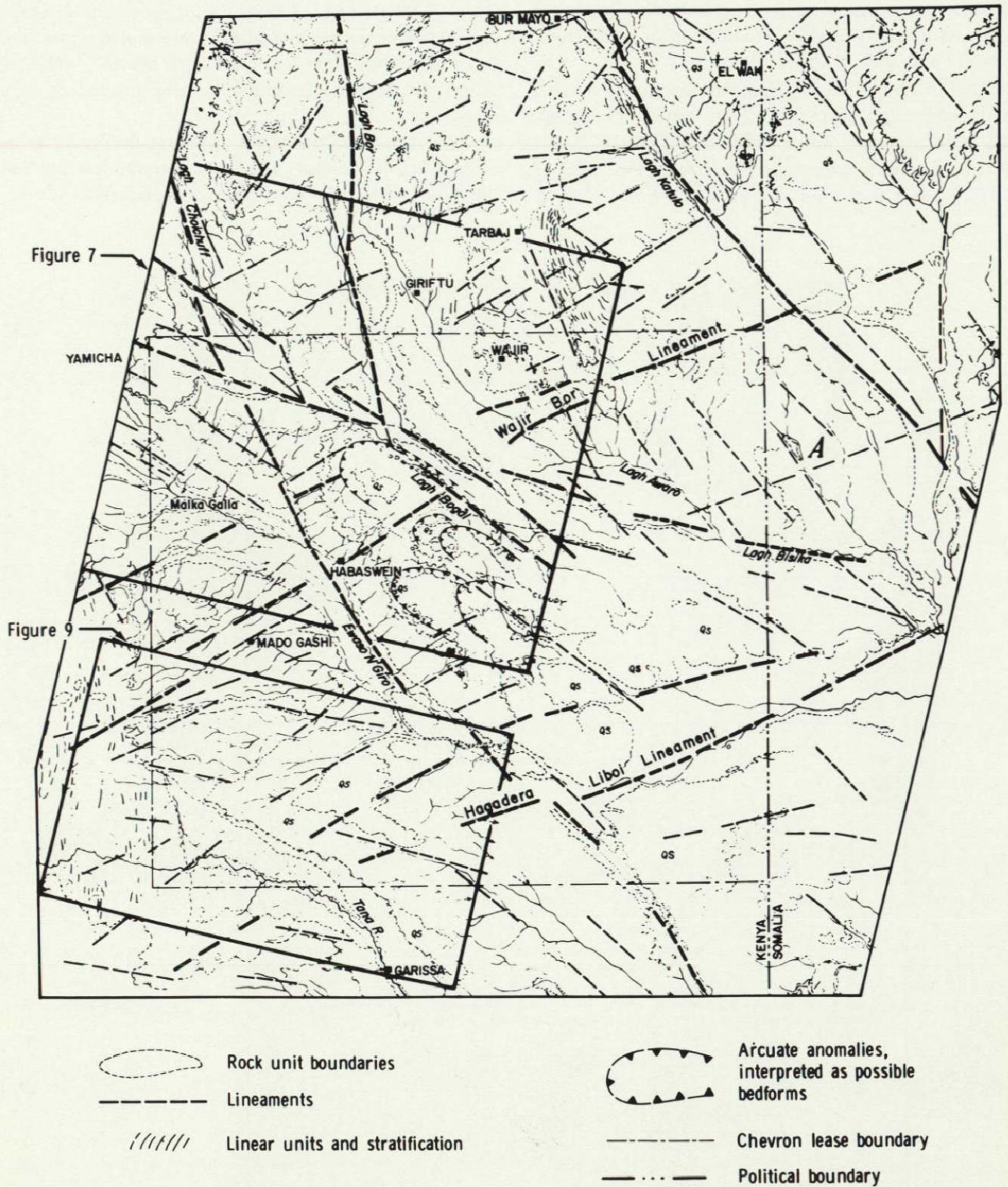

Figure 6.— Interpretation of Landsat imagery in the area shown in figure 5.

Lineaments are a major feature in Kenya, as shown on the interpretation map (fig. 6) and on the color composite image covering the northwestern part of the Chevron license area (fig. 7). It should be noted that the

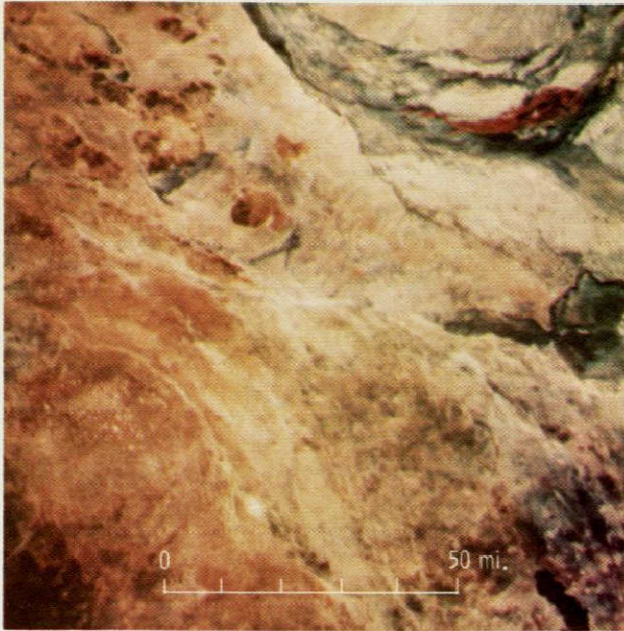

Figure 7.— Color composite Landsat image of the northwest part of the Chevron license (location shown in figure 6).

lineaments and other features are much more apparent on our laboratory imagery than on the printed versions shown here.

The Lagh Bogal lineament, which trends northwest across figure 7, is particularly significant because it marks the northeast boundary of a basinal feature confirmed by later geophysical surveys. Results of these gravity, magnetic, and seismic surveys were made available through the courtesy of Chevron and are summarized in figure 8. Note that the Lagh Bogal lineament also coincides with a subsurface fault, independently interpreted from the geophysical surveys, that forms the northeast boundary of the basin. Geophysical data indicate that the west border of the basin is not a single major fault zone but a combination of step faults and tilting. Three major image linear trends intersect in the northeast part of the Chevron license area and coincide with interesting gravity and magnetic highs shown in figure 8. This may represent a failed triple junction associated with the East African rift system. The major lineaments extend beyond the limits of the mosaic and are the sites of several large volcanoes.

A remarkable amount of lithologic information was also interpreted from Landsat images. On the color composite (fig. 7), young volcanic flows occur in the

west-central and northwest corner of the image. In the southeast part are large arcuate color bands that the investigator suggests are depositional patterns in near-surface clastic beds. A brownish-gray colored lobe extends southeast from the northwest part of the image and marks the outcrop of crystalline basement rocks in which foliation trends are discernible on the original image.

Additional valuable lithologic information occurs on the figure 9 color composite covering the southwest part of the license area. Dark basement rocks with north-trending linears, probably caused by foliation, crop out in the southwest part of the image. To the east of the basement outcrops, and probably in fault contact, are sands and clays of Pliocene age forming a triangular light-colored outcrop through which flows the Tana River with its associated riparian vegetation. The Pliocene strata are capped to the north by a brownish-red duricrust layer. Directly below the duricrust contact, a slightly darker unit in the Pliocene sequence thickens toward the southeast into the basin. According to the investigator, this basinward thickening in the license area has only been observable on the Landsat image.

Based largely on the Landsat interpretations, Chevron acquired a second exploration license area adjoining the original area on the northwest (fig. 8). This is an example of an economic exploration decision based on remote-sensing information.

A circular drainage anomaly in southeast Georgia that was first discovered on Landsat imagery was described by Pickering. It was more closely defined on color-infrared U-2 high-altitude photography. Two unsuccessful wildcat wells were drilled on the anomaly by a major oil company. The lack of production should not be unduly discouraging; this is the fate of at least 90 percent of all wildcat wells drilled on the basis of the best available technology. The significant fact is that subsequent ground and geophysical surveys proved the anomaly worthy of drilling.

A mineral exploration use of Skylab photography was demonstrated in the Death Valley region (G-7, vol. I-B). The circular anomaly in figure 10 is enhanced by the light cover of snow. The anomaly is not a single igneous intrusive, but occurs within a granitic body of Cretaceous age. It is bounded along the north margin by metamorphosed marine strata of Paleozoic age, where mineralization occurs as shown by copper staining in the prospect pit of figure 11. This relatively unexplored feature may be the site of economic mineral deposits.

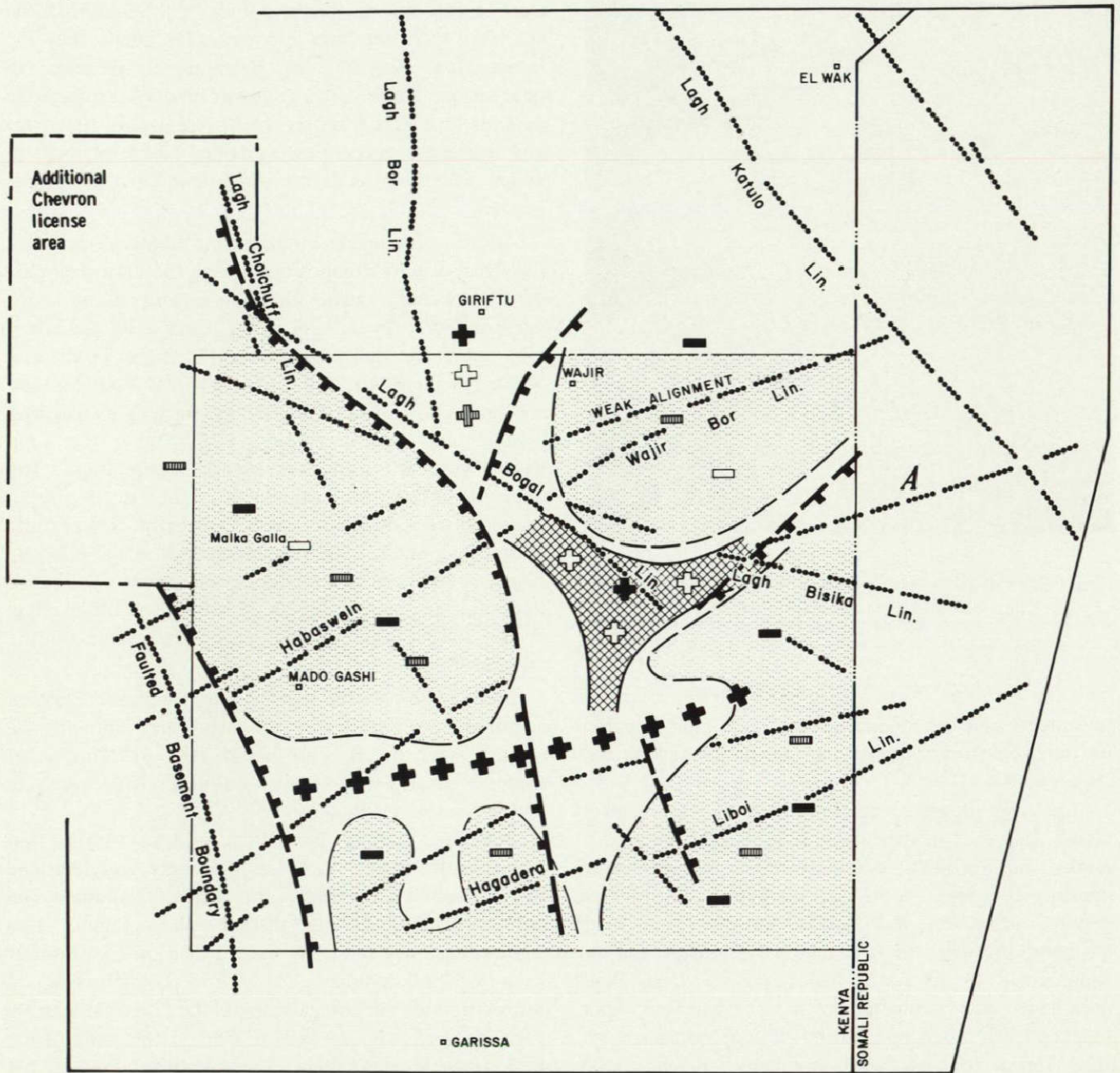

Legend

.....	Lineaments	Anomalies and axes		
[Stippled Box]	Low or basin	(Magnetic)	(Gravity)	(Seismic)
[Cross-hatched Box]	Intrusive high	+	+	+
[Fault Symbol]	Fault (gravity or magnetic)	+	+	+
-----	Chevron lease boundary	-	-	-
.....	Political boundary	-	-	-
				High
				Low
				}
				As interpreted structurally

Figure 8.— Features found on Landsat images compared with generalized geophysical trends in the area of figure 5.



Figure 9.— Color composite Landsat image of the southwestern part of the Chevron license (location shown in figure 6).

DIGITAL IMAGE PROCESSING

The increasing application of digital processing methods to Landsat imagery was another trend apparent at the Houston symposium.

Methods

The following partial list of digital image processing and enhancement methods was given (ref. 4).

1. Cosmetic corrections
 - a. Scan dropout replacement
 - b. Banding correction
 - c. Noise removal
2. Geometric corrections
3. High-pass filtering
4. Contrast enhancement
5. Spectral ratio images
6. Edge enhancement
7. Directional filtering
8. Spectral classification
9. Temporal change detection

These methods are especially applicable to Landsat imagery which is available in digital format.

Spectral Ratio Images

A Landsat spectral ratio image is prepared in the following manner. For each of the 7.6 million picture elements (pixels) in a scene, the reflectance value in one

band is divided by the reflectance value in another band. The resulting ratio values are digitally stretched to provide optimum contrast and then plotted as a black-and-white transparency. The 4 Landsat spectral bands can be combined in this manner to produce 6 primary ratio images plus their inverse ratios for a total of 12 ratio images.

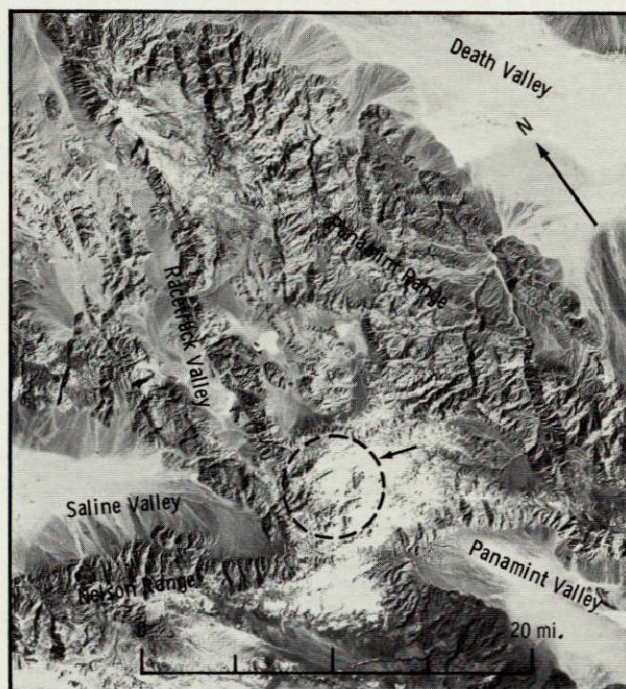

Figure 10.— Panamint Range, California and Death Valley (SL4-94-013), showing circular anomaly.



Figure 11.— Prospect pit at location indicated by the arrow in figure 10. Green stain is copper silicate mineralization.

A ratio image enhances variations in the slopes of the spectral-reflectivity curves between the two wavelength bands that are ratioed. This has the disadvantage that materials with different albedos but similar spectral-reflectivity slopes will be inseparable on a ratio image. A distinct advantage is that ratio images minimize differences in illumination so that a material has the same appearance in sunlit or shady areas (ref. 5). The black-and-white transparencies of three ratio images may be converted to color and registered to produce a color-ratio composite image. An example from the Goldfield, Nevada, area is shown in figure 12, where basaltic and intermediate rocks appear white, felsic rocks are pink, and playas appear blue. The altered areas are represented by green to dark green and brown to red-brown. As shown in figure 13, the green areas generally are limonitic, and the brown to red-brown areas represent light-colored hydrothermally altered rocks. The area of figures 12 and 13 was originally reported in reference 5. This original ratio study was extended to the west, where all hydrothermally altered areas are green to dark green in the color-ratio composite; none of the altered areas appear brown or red-brown in color. Limonitic shale and siltstone are mineralogically similar to the altered rocks and cannot be discriminated on ratio images.

In the Arabian Shield, similar color-ratio composite images showed that some rock units were characterized by distinct color, but others were not separated (G-22, vol. I-B).

In the Wind River Basin of Wyoming, color-ratio composite images were used to distinguish subtle surface features (G-5, vol. I-B).

Spectral Classification

In Pakistan, multispectral classification techniques were used to prospect for porphyry copper deposits. The techniques are described in the following paper (and in G-26, vol. I-B).

Problems

These descriptions of successful digital image processing necessarily omit the frustration and pitfalls inherent in manipulating large volumes of data. These are summarized in the following list plagiarized from the bulletin board of an anonymous programmer.

Software development sequence:

1. Wild enthusiasm
2. Disillusionment
3. Mass confusion (implementation phase)
4. Search for the guilty
5. Punishment of the innocent
6. Rewards for the nonparticipants

Anyone involved with data processing will perceive more truth than humor in this sequence.

There are also technical problems associated with digital processing of Landsat data for mineral exploration. Goldfield and Pakistan are particularly favorable because the altered areas are large enough to be sampled by a number of individual picture elements. The mineralized training area in Pakistan, for example, is 10 or more pixels in size. Unfortunately, however, many economically significant areas of surface alteration and mineralization are smaller than the pixel spot size of the multispectral scanner. Figure 14 shows typical gossans, which are limonitic surface deposits representing weathered sulfide deposits, exposed in an ancient mining area of the Arabian Shield (ref. 6). Plotted to the same scale is the 57- by 79-meter pixel spot size of the Landsat multispectral scanner. Any of the gossans occupies only a portion of the picture element, and its reflectance value is integrated with that of the adjacent country rock. It is unlikely that these typical gossans are detectable on Landsat imagery, regardless of any amount of digital processing. This suggests a higher resolution (smaller pixel) system, but the volume of data would be greatly increased. Perhaps such a high-resolution system could be reserved for imaging areas of mineral potential.

Another problem is that the four spectral bands of Landsat may be too broad for the spectral definition required to discriminate many altered areas from the country rock. Also, it may be advisable to extend the spectral range of the scanner beyond the present cutoff point at 1.1 micrometers because significant spectral differences occur out to 2.5 micrometers.

POPULAR MISCONCEPTIONS

A popular misconception is revealed by the common question: "How many oilfields have been found from Landsat imagery?" This question has been prompted in part by news items stating that Landsat would find new oilfields and mineral deposits. I am reasonably certain that no oilfield has yet been found as a direct result of Landsat and I doubt that this will ever be established.

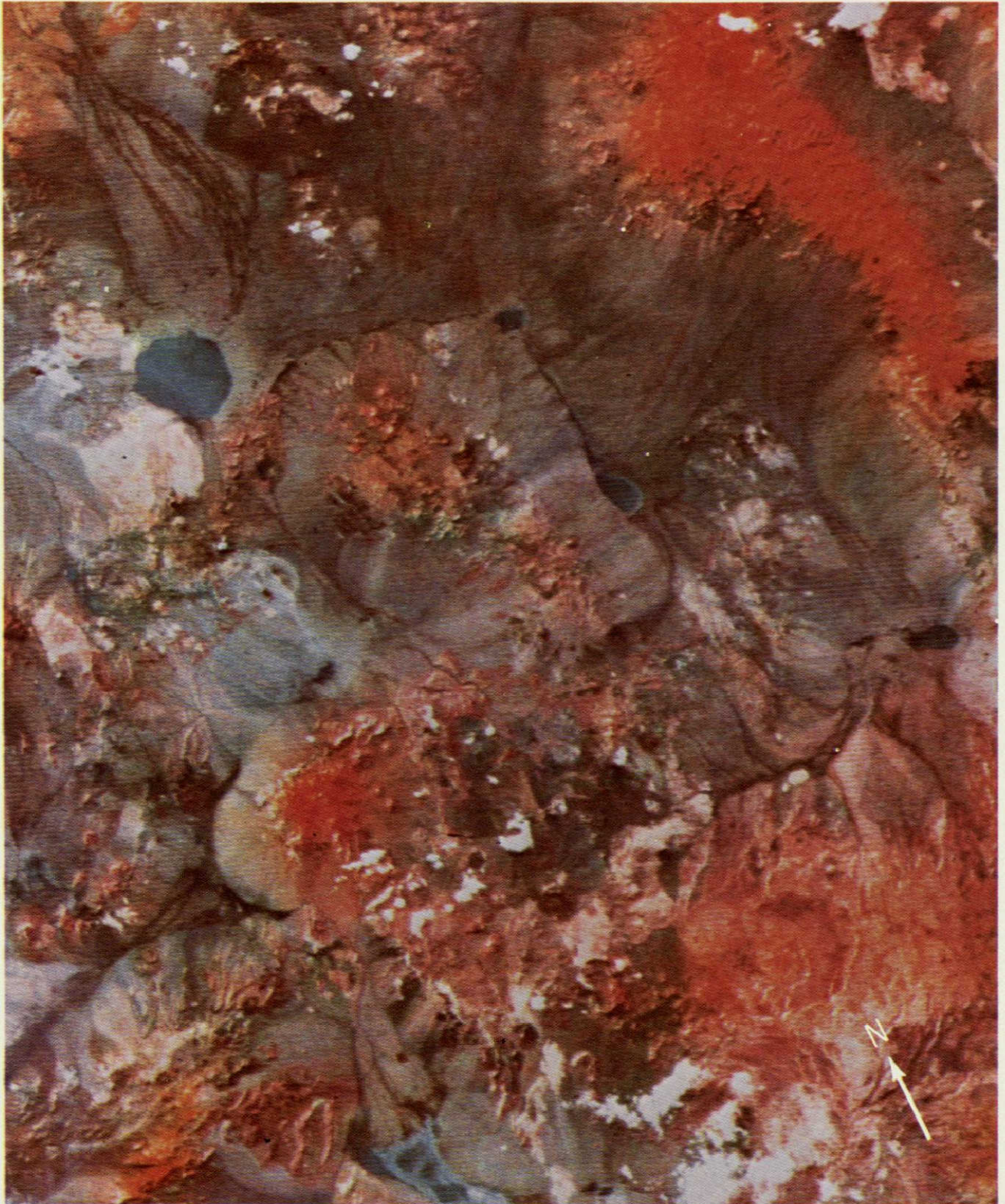

0 10 20 mi.

Figure 12.— Color-ratio composite of Landsat bands showing south-central Nevada. Interpretation is in figure 13.

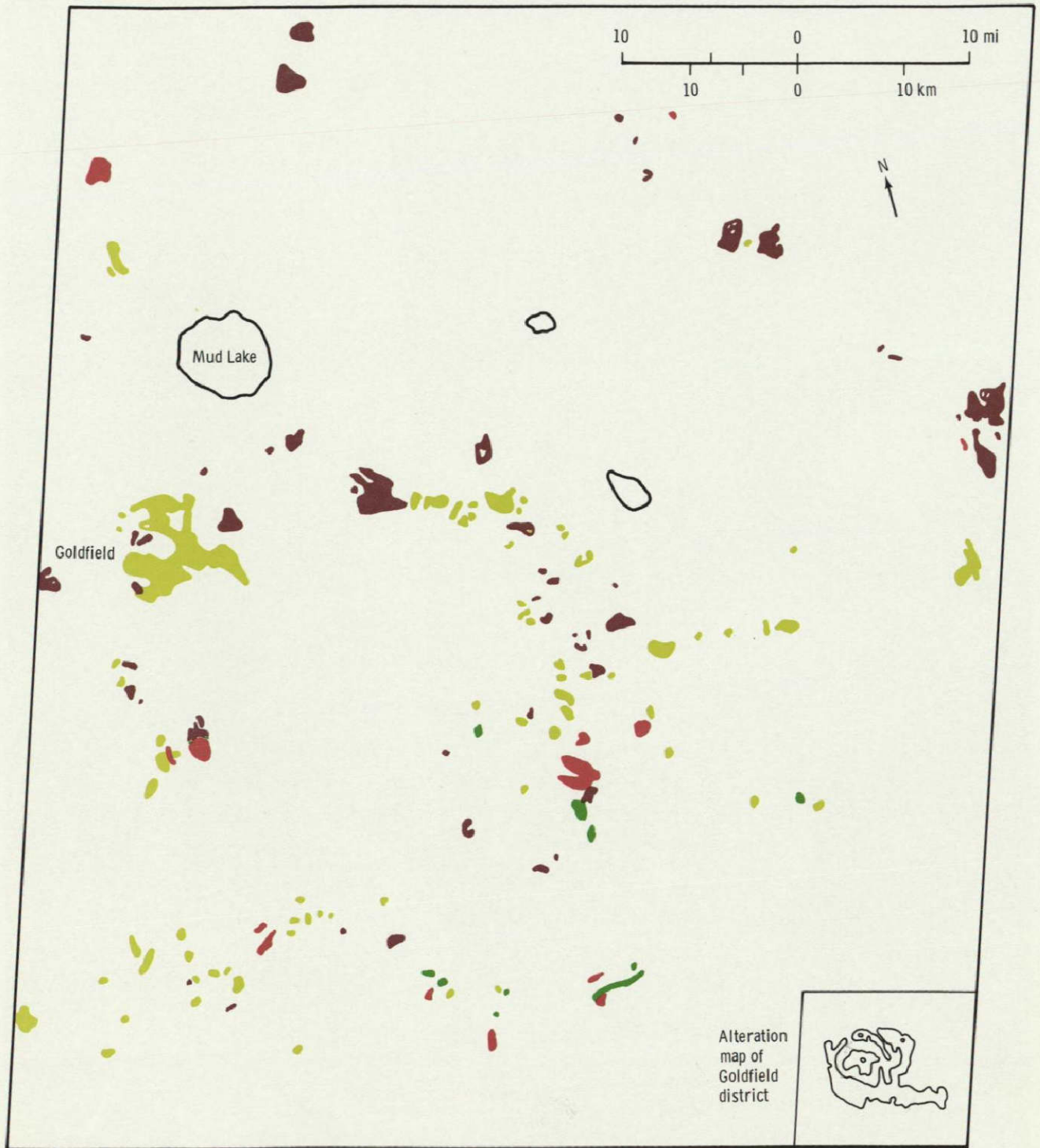

Figure 13.— Color signatures of altered rocks from color-ratio composite in figure 12. Light green indicates limonitic areas; dark green, altered volcanics; brown, light-colored volcanics; and red-brown, white silica-rich volcanics.

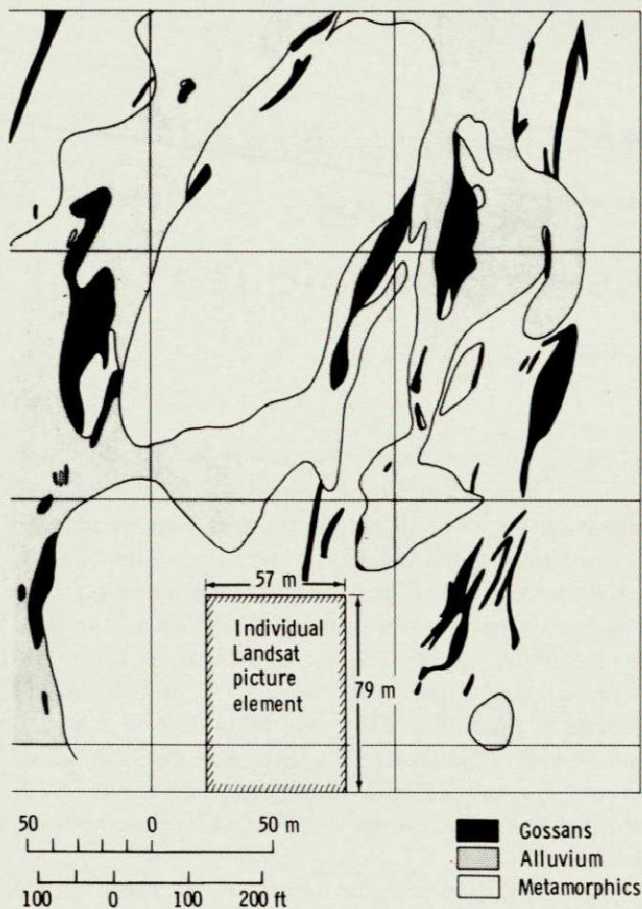

Figure 14.— Size comparison of typical gossans with a Landsat picture element. Locality is the Rabathan ancient mining district in the Arabian Shield (ref. 6).

The reasons for this are as follows.

1. Reasonable numbers of images have been available for less than 2 years, and then we had to learn how to use them. For reference, an exploration project requires at least 5 years from inception to drilling. Today, the environmental impact studies alone can consume several additional years.

2. The easily discovered oilfields on land have all been found, and Landsat is being applied to the difficult remaining areas.

3. Oil exploration is a complex process that involves diverse technologies including gravity and magnetometer

surveys, remote sensing (both satellite and aircraft), geologic field work, seismic surveys, stratigraphic core holes, subsurface studies, paleontology, and organic geochemical analyses. Drilling decisions are based on many or all of these methods, and no single method, or geologist, can take credit for a discovery. Conversely, no single method or geologist is responsible for the dry holes.

This paper has demonstrated three instances in which remote sensing was successfully employed by oil and gas companies, but not in the dramatic sense of "finding an oilfield." I have no doubt that this trend will continue and accelerate.

REFERENCES

1. Johnston, J. E.; Miller, R. L.; and Englund, K. J.: Applications of Remote Sensing to Structural Interpretations in the Southern Appalachians. U.S. Geol. Survey J. Res., vol. 3, 1975, pp. 285-293.
2. Allen, C. R.; et al.: Displacements on the Imperial Superstition Hills, and San Andreas Faults Triggered by the Borrego Mountain Earthquake of April 9, 1968. U.S. Geol. Survey Prof. Paper, 1972, pp. 87-104.
3. Allen, C. R.: Geological Criteria for Evaluating Seismicity. Bull. Geol. Survey America, vol. 86, 1975, pp. 1041-1057.
4. Sabins, F. F.: Oil Exploration Needs for Digital Processing of Imagery. Photogramm. Eng., vol. 40, 1974, pp. 1197-1200.
5. Rowen, Lawrence C.; Wetlaufer, Pamela; Goetz, Alexander F. H.; Billingsley, Fred C.; and Stewart, John H.: Discrimination of Rock Types and Detection of Hydrothermally Altered Areas in Southcentral Nevada by the Use of ERTS Images. U.S. Geol. Survey Prof. Paper 883, 1974.
6. Earhart, R. L.; and Mawad, M. M.: Geology and Mineral Evaluation of the Wadi Bidah District, Southern Hijaz Quadrangle, Kingdom of Saudi Arabia. U.S. Geol. Survey Open File Saudi Arabia Investigative Report SA-119, 1970.

A Search for Sulfide-Bearing Areas Using Landsat-1 Data and Digital Image-Processing Techniques*

R. G. Schmidt,^a B. B. Clark,^b and R. Bernstein^b

INTRODUCTION

Mapping and mineral prospecting were undertaken at Saindak, Pakistan (fig. 1), in 1962 because the locality was considered one of the more favorable for prospecting in the Chagai District. In 1962, after discovery of the disseminated copper sulfide deposit at

Saindak, it was reasoned that tonal changes and topographic expression related to hydrothermal alteration might be detected by optical remote sensing.

Two investigations concerned with direct detection of sulfide mineralization and hydrothermal alteration using Landsat-1 multispectral scanner (MSS) data have used the porphyry copper deposit at Saindak as a test site because the deposit is large, has well-developed alteration zones, has little vegetation, is well mapped, and is well exposed and undisturbed; also, the senior author was familiar with the deposit and region. Both investigations used image 1125-05545 (November 25, 1972).

The first investigation (ref. 1) involved visual examination of false-color composite images to select light-toned areas that might be related to hydrothermal alteration. Relatively few areas were selected for field checking, and none proved to be mineralized. Later analysis of the results indicated that the method must be considerably modified for greatest effectiveness in mineral exploration.

In making the second investigation, digital-computer processing was used to classify data from the four multispectral scanner bands (4, 5, 6, and 7) to remotely identify the material at the surface. In 1973, experimental work was undertaken by Ralph Bernstein and Bruce Clark of the Federal Systems Division, IBM Corporation, on digital processing of Landsat-1 data as a method of locating mineral deposits, using the Saindak area, as suggested by Schmidt (ref. 1). Later, the experiment was resumed by the IBM Corporation on behalf of the U.S. Geological Survey.

Clark extracted numeric data for the four multispectral bands for each pixel from small test areas chosen to represent single rock types and single

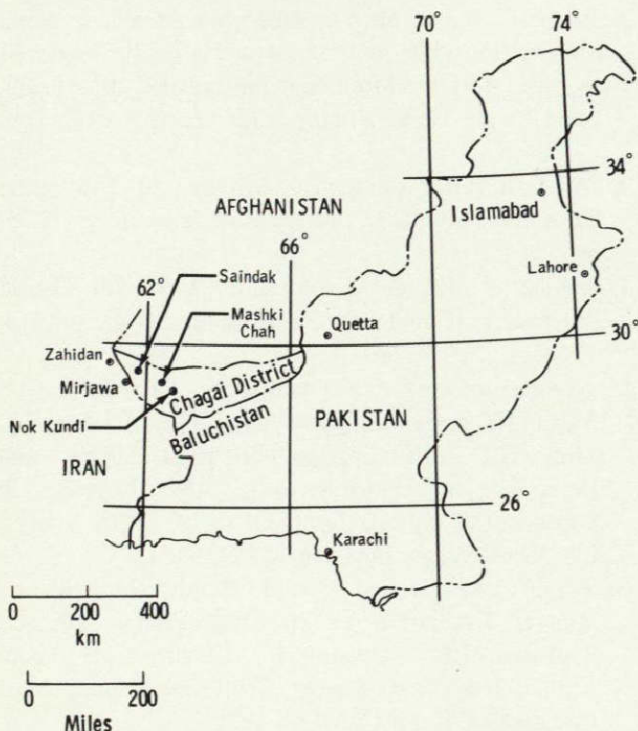

Figure 1.— Index map showing the Chagai District and Saindak, Pakistan.

*Based on paper G-26 (vol. I-B).

^aU.S. Geological Survey, Reston, Virginia.

^bIBM Corporation, Gaithersburg, Maryland.

rock-alteration types. The classification tables for the area of the known deposit at Saindak were revised and tested five times. The final table was used for the mineral evaluation of 2100 square kilometers (810 square statute miles) of the Chagai District, which was considered to have a good potential for porphyry copper deposits, but in which widely distributed eolian sand made visual analysis of color composites particularly troublesome (application area, fig. 2).

Following completion of digital-classification maps of the application area, a field check was made during October 13 to 31, 1974, of some of the prospecting sites selected in the two studies, and five mineralized areas were found. Data were collected that were useful for evaluating and improving the methods used. In 1975, further changes were made in the style of the classification tables, and the new tables were tested in the same parts of the Chagai District, Pakistan.

In the experiment leading to the field check in October 1974, a direct, simple, and inexpensive application of Landsat-1 data to mineral exploration was tested in one particular geologic environment. Simplicity was achieved and costs were controlled by having few revisions of classification tables, no ground checks prior to application, and no incorporation of ground-collected quantitative reflectance data into the study.

REGIONAL GEOLOGY

The Mirjawa ranges, where Saindak is located, and the Mashki Chah region, where the classification method was applied, have somewhat different regional geological aspects. The rocks of both areas are Cretaceous to Quaternary in age. The Mirjawa range area has mostly folded (along northwest trends) and much faulted sedimentary and volcanic-sedimentary strata and relatively small amounts of intrusive and extrusive igneous rock. The detailed geology of the Saindak area (ref. 2) is fairly representative of the geology of the more extensive border region. Cretaceous sedimentary rocks represent a wide variety of marine and continental depositional environments; lower Tertiary rocks are mostly shallow marine, and upper Tertiary-Quaternary strata are largely of continental origin.

In the Mashki Chah region, in a western section of the Chagai District hills, gently folded pre-Cretaceous and undeformed Tertiary volcanic rocks with low dips (probably initial) are common and widespread, and intrusive rocks are more abundant than in the Mirjawa ranges. Faults are also present. The folding lacks the strong linear pattern characteristic of the Mirjawa range. Recently dried or still weakly flowing sinter-depositing saline springs, plus a few fumaroles on the volcano

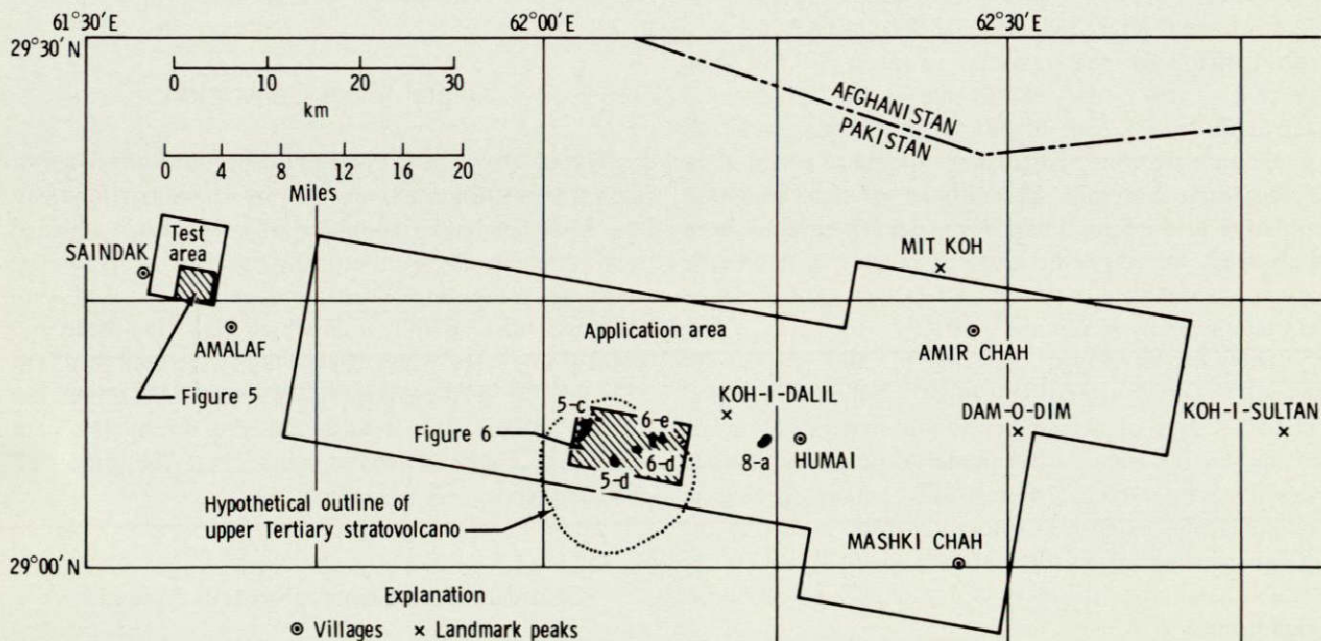

Figure 2.— The Saindak-Mashki Chah area of the western Chagai District, Pakistan, showing the control area near Saindak and the area where the digital-classification method was applied. The numbered locations are mineralized prospect sites described in the text.

Koh-i-Sultan, indicate that there is still hydrothermal activity.

For all of the western part of Pakistan, 1:253 440 photogeologic reconnaissance maps (ref. 3) are available, but probably less than 1 percent of the Chagai District has been mapped in detail.

ECONOMIC GEOLOGY

Mineral reconnaissance in the Chagai District has been spotty and mostly for high-grade deposits. If a porphyry copper deposit had been noticed during these early investigations, it might have been passed over as too low grade for consideration at that time. Several large areas of the Chagai District containing abundant volcanic rocks of intermediate and felsic composition, and small bodies of hypabyssal intrusive rocks of Cretaceous through Pleistocene age may be considered to have a good potential for large sulfide deposits of the porphyry copper type.

At Saindak, a group of small copper-bearing porphyritic quartz diorite stocks cut northward across the folded lower Tertiary stratigraphic section (ref. 2). The stocks may be cupolas on a single barely exposed granitic body 8 kilometers (5 statute miles) long and as much as 1.5 kilometers (1 statute mile) wide, or separate but related intrusive bodies. The group of stocks is surrounded by zones of contact metamorphism and hydrothermal alteration. The stocks are enclosed in a sulfide-rich zone that contains as much as 15 volume percent pyrite; the sulfide-rich zone in turn is surrounded by a zone of propylitic alteration in which pyroclastic rocks in particular are altered to a hard, dark epidote-rich hornfels. Descriptions of the alteration zonation in the central part of the deposit have not been published, but there are areas of much quartz-sericitic alteration and areas of potassic alteration, some of which contain much hydrothermal biotite.

The well-developed pattern in the district of hydrothermal-alteration zones and the general characteristics of the copper sulfide mineralization are similar to the simple ideal model of porphyry deposits described in reference 4, but only detailed geological mapping plus extensive exploration drilling, such as the program underway by the Government of Pakistan, can establish whether the deposit is actually of economic significance.

The sulfide-rich zone including both the intrusive porphyry stocks and the adjacent pyrite-rich country rock has been eroded to form a valley in which the surficial materials are light-toned. Desert soils associated

with many porphyry copper deposits the world over have distinct red and orange color anomalies, and this is true at Saindak as well, where the mineral natrojarosite ($\text{NaFe}_3(\text{SO}_4)_2(\text{OH})_6$) has been identified in the pigmented material. In the central valley at Saindak, however, alluvial and windblown grains of sand dilute or cover part of the colored soil.

In plan view, this valley is encircled by a symmetrical rim of hills more rugged and darker in tone than the surrounding region (ref. 2, fig. 2). These hills, generally corresponding to an erosion-resistant zone of hornfels and propylitic alteration, form the outer boundary of the whole exploration target.

COMPUTER-AIDED INFORMATION-EXTRACTION

Computer-aided information-extraction experiments were conducted to identify potential sulfide ore-bearing localities. The experimental approach is summarized in figure 3. Shown here are the source data used, the digital processing applied to the source data, the products generated, the analysis conducted, and the final products. By a combination of digital image processing and information extraction, and manual analysis and evaluation, three processing operations were performed: digital image generation, support data generation and analysis, and multispectral classification.

Digital Image Generation

The uncorrected Landsat multispectral scanner sensor data were reformatted into 185-by 185-kilometer areas, and each band was radiometrically (intensity) adjusted and systematically geometrically corrected (ref. 5). The resulting computer-compatible tape (CCT) data were then recorded on film from which black-and-white and color prints were made. These prints were used as aids in selecting the field prospecting sites during the evaluation of the classification results and also during the field checking. Figure 4 shows band 5 of the processed Pakistan scene.

Support Data Generation and Analysis

The formatted but uncorrected CCT's were used for data analysis prior to the multispectral classification operation. Shade prints (computer printouts providing the reflectance sensed in each spectral band) for selected

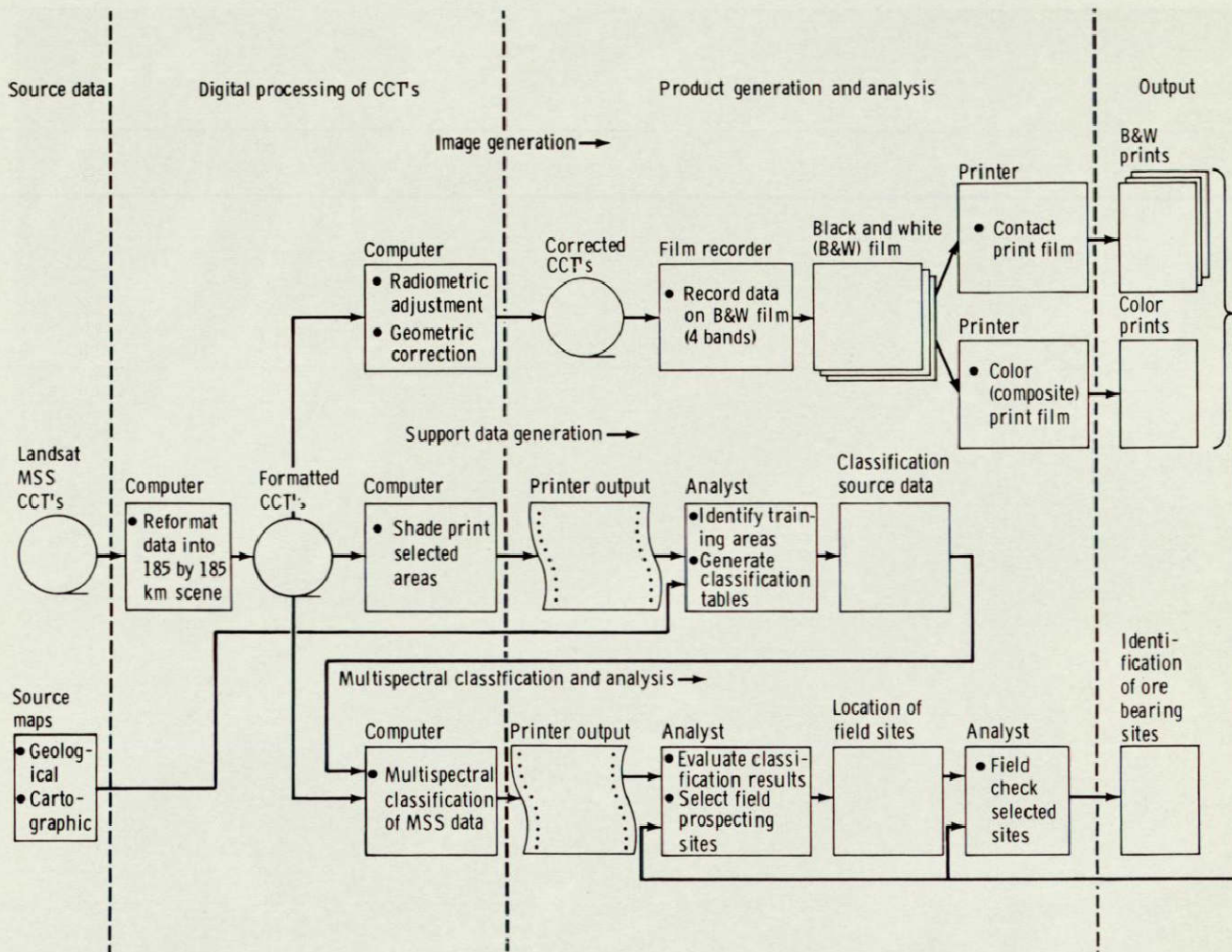

Figure 3.— Graphic summary of digital processing and data analysis performed in the experiment.

areas were prepared and used as maps for precise location of individual data rectangles (pixels) relative to known ground features and known rock types. Numeric data for the four MSS bands were extracted for each pixel in the known areas, and maximum and minimum sensed-reflectance limits were chosen for each rock type. A known copper sulfide-bearing deposit at Saindak was the source of data used to prepare the classification tables. Five revisions were made and tested, and one alternate classification table was tried, resulting finally in the classification table shown in table I. Table I shows three general types of materials: (1) mineralized rock, including intensely hydrothermally altered (quartz-sericite zone) quartz diorite and pyritic rock, (2) alluvial and eolian materials, recently moved dry-wash alluvium and eolian sand being the materials most likely to be confused with the first group, and (3) a loose category of dark surfaces that includes both

hornfels-type bedrock and many areas of desert-varnished lag gravels (especially in class 10). These tables of reflectance limits were then used on an interactive basis to classify a nearby region within the same Landsat scene in which copper sulfide-bearing areas were suspected but in which no deposits were known (application area).

Multispectral Classification and Analysis

A spectral-intensity discrimination program was used for multispectral classification on the application area, using the tables prepared for the Saindak deposit. The program tested the reflectance of each picture element within the application area against the maximum and minimum reflectance limits in the table and determined into which surface class (rock type) the picture element



Figure 4.— Digitally enhanced Landsat MSS band 5 image 1125-05545 of Pakistan and Iran. The areas studied in the experiments are in the northern quarter of the image.

belonged. The symbol for that class was printed on a computer listing as part of a classification map. When the observed values fit more than one class (when classes were set up with overlapping limiting values), a pixel was placed in the class that was considered first in the search sequence.

The classification table resulting from five revisions was used to evaluate an adjacent area of 2100 square kilometers considered to have good potential for porphyry copper deposits in the western Chagai hills (fig. 2). The results were printed out in 13 computer-generated vertical strip maps. These maps were

examined for groups of pixels classified as mineralized quartz diorite and pyritic rock, and about 50 groups or concentrations were identified. Each was then evaluated for probability of correct classification, relationship to concentrations of other classes, and comparison with known rock types and occurrences of hydrothermal mineralization. From this examination, 30 localities most deserving reconnaissance checking in the field were chosen. The locations of these targets were marked on an enlarged (1:250 000) digitally enhanced image of MSS band 5 to simplify location on aerial photographs and in the field.

TABLE I.- DIGITAL CLASSIFICATION TABLE USED IN 1974 MINERAL EVALUATION
IN THE CHAGAI DISTRICT, PAKISTAN

Class number	Rock type	Symbol	Multispectral scanner bands						
			4	5	6	7			
1	Mineralized rock	Quartz diorite	High reliability	●	46 to 50	52 to 60	50 to 60	18 to 22	
2					Low reliability	⊗	44 to 45	52 to 60	45 to 49
3		Pyritic rock	High reliability	⊗			41 to 45	47 to 54	39 to 44
4					Low reliability	X	41 to 45	47 to 54	39 to 44
5	Dry-wash alluvium	High reliability	=	39 to 46			39 to 46	35 to 44	14 to 17
6				Low reliability	-	41 to 45	46 to 51	42 to 49	18 to 19
7	Boulder fan		+			33 to 40	39 to 46	30 to 35	9 to 16
8	Eolian sand	High reliability	.	38 to 44	46 to 54	42 to 51	18 to 22		
9				Low reliability	,	45	46 to 127	42 to 127	18 to 63
10	Various dark surfaces including hornfelsic rock outcrops, desert-varnished lag gravels, and detrital black sand	High reliability	I			33 to 36	28 to 38	29 to 35	11 to 15
11				Low reliability	#	24 to 35	19 to 27	20 to 32	8 to 12
12						H	29 to 36	28 to 38	20 to 28

As part of the field check, all anomalous areas were first examined on stereoscopic pairs of 1:40 000-scale aerial photographs. At this point, it was possible to reject seven areas as related to windblown sand. Nineteen sites were examined in the field, and four desirable sites were not reached in the field checks. Five sites were found to be extensive outcrops of hydrothermally altered sulfide-rich rock. Two additional sites contained altered rock with some sulfide but seemed less attractive for prospecting at the time.

Evaluation of Results

Mineralized rock is believed to have been generally identified correctly, but much other light-toned surface was also classified as mineralized. Alluvium was mostly classified accurately. Perhaps only 25 percent of dune

sand was correctly identified by means of table I, most sand having been classified as mineralized rock. Classification of areas of dark rock outcrops and several types of lag gravels yielded different combinations of classes 10, 11, and 12 and made it possible to differentiate between these materials.

In table I, four of the main surface types are each represented by a high and a low reliability class. The high reliability or more restrictive class has reflectance limits in at least one band that make it exclusive from all other high reliability classes; the secondary class has reflectance limits that overlap the limits of at least one other class. The classes of two reliability levels have not been used in later tables. In figure 5, the classification map made by using table I is compared with a geologic map.

In preparing table I, as the acceptable reflectance limits of a class were narrowed, fewer matches were

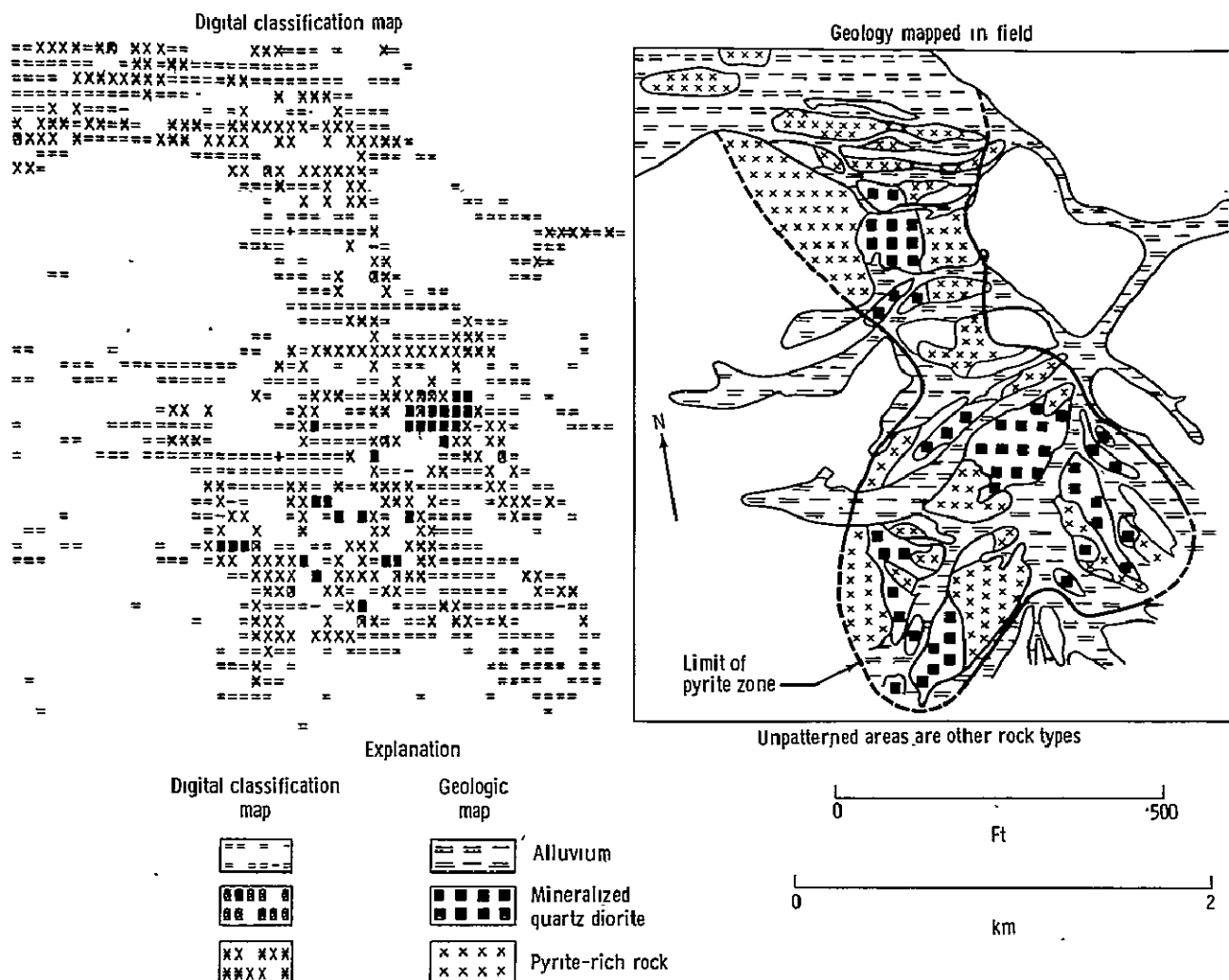

Figure 5.— Comparison of digital-classification map made by using table I and geology mapped in field studies (Saindak porphyry copper deposit, Pakistan). (Geologic map is based on ref. 6.)

found. In classes 1 and 2 (mineralized quartz diorite, table I), for example, if limits were chosen that included most pixels in the training areas and also many pixels in all the areas of known mineralization, false classifications were obtained in dry-wash material. The limits were subjectively adjusted wider or narrower so that enough points were classified correctly in the areas of known mineralization to call attention to those areas, and the false classifications were reduced to an acceptable level. Because revisions to the tables are time-consuming and successive revisions generally achieve diminishing improvement, the final tables used in this experiment have been revised only a few times.

The three dark-surface classes were established on the basis of small samples of particular rock formations in

training areas, but the classes were very unsatisfactory in discriminating between the three formations. The classes would have been abandoned except that various combinations of the three classes delineate areas of dark rock outcrops and lag gravels. The printout of class 11 (symbol #), in particular, resulted in abundant pixel groups just inside the perimeter of the propylitic zone at Saindak.

The data collected in the field check made it possible to evaluate the identification accuracy of all the surface types, not the mineralized rock alone, and to revise the tables to improve accuracy. A new style of table was adopted, having several relatively narrow classes spanning the expected albedo range for each rock type, but having no high and low reliability classes (table II).

TABLE II.-REVISED CLASSIFICATION TABLE PREPARED IN APRIL 1975

Class number	Rock type	Symbol	Multispectral scanner bands			
			4	5	6	7
1	Detrital black sand	,	27 to 30	26 to 28	23 to 26	9
2		,	28 to 32	27 to 31	25 to 27	10
3	Dry-wash alluvium	-	38 to 44	39 to 44	35 to 38	13 to 16
4		=	43 to 48	44 to 48	38 to 43	15 to 18
5	Eolian sand	.	49 to 54	59 to 66	54 to 62	23 to 27
6		.	43 to 48	50 to 58	46 to 55	19 to 24
7		.	37 to 43	41 to 50	38 to 47	15 to 20
8		.	33 to 38	35 to 42	32 to 39	12 to 16
9	Mineralized rock	0	39 to 42	41 to 45	33 to 38	14 to 16
10		θ	41 to 44	44 to 48	37 to 41	16 to 18
11		⊖	43 to 46	47 to 51	41 to 45	17 to 20
12		∅	44 to 46	50 to 53	45 to 48	18 to 20
13		⊘	46 to 49	53 to 56	48 to 51	19 to 21
14		●	49 to 52	56 to 59	51 to 54	20 to 22
15	Dark surfaces, except detrital black sand	l	33 to 36	28 to 38	29 to 35	11 to 15
16		#	24 to 35	19 to 27	20 to 32	8 to 12
17		H	29 to 36	28 to 38	20 to 28	9 to 14

The limiting values for each class span relatively narrower ranges than those in table I, and more classes are required. The use of several classes for a range in albedo from similar surface types is designed as a simple way to compensate for variations in reflectance angles, especially those that were caused by southeast- and northwest-facing slopes.

NEWLY IDENTIFIED AREAS OF MINERALIZATION

Four of the areas of mineralization newly discovered in this investigation are in the central core area of the eroded remnant of a large stratovolcano (figs. 2 and 6). A fifth is about 15 kilometers to the east. Sites 5-d, 6-d,

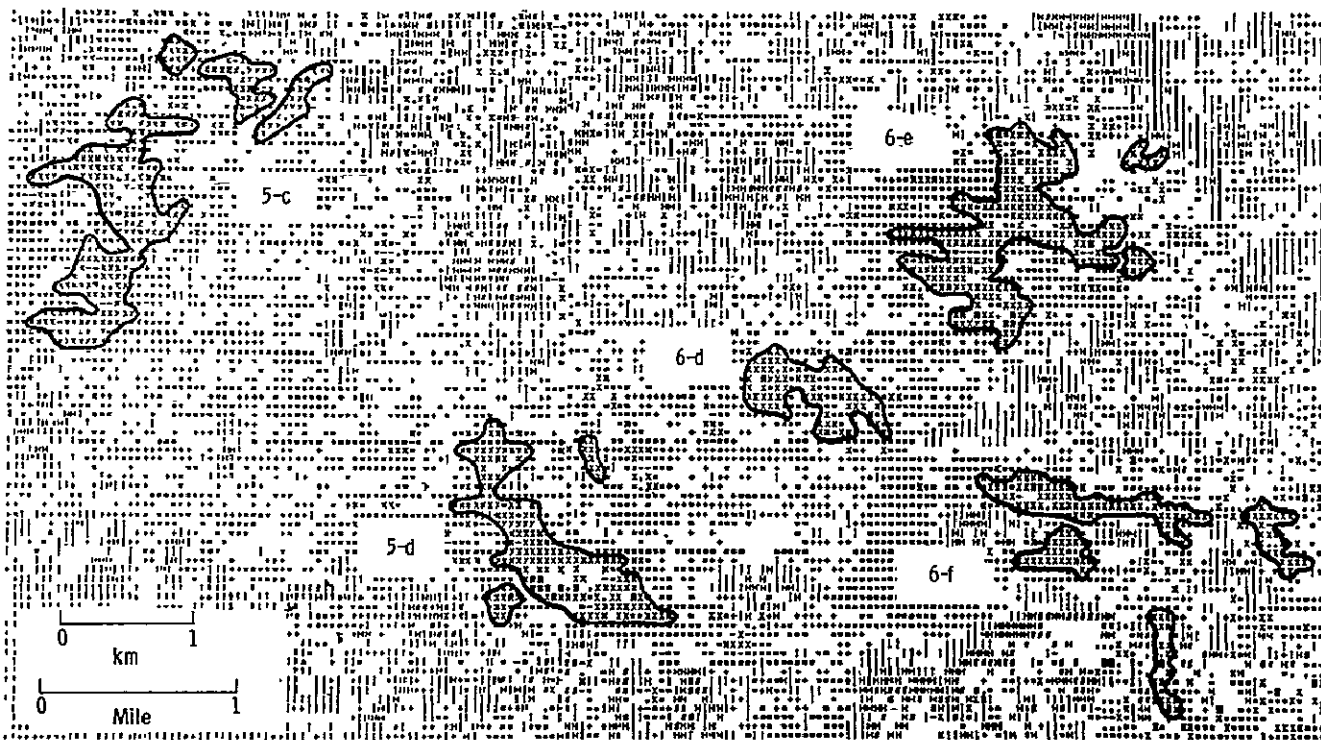

Figure 6.— Classification map of an area west of Koh-i-Dalil (fig. 2) showing five areas classed as “mineralized.” Reconnaissance field checks showed that some hydrothermal alteration and sulfide mineralization are present in each area. Area 6-d seems the most promising for further study. The northeast end of 5-c, the west end of 6-f, and the northeast end of 6-e were not adequately field-checked. The east end of 6-f is mostly dune sand.

and 6-e may be parts of a single large mineralized body because the bedrock between them is covered by Holocene alluvium. Site 5-c seems to be a separate mineralized area nearby. Site 8-a (fig. 2), 15 kilometers east of 5-d, is well outside the core of the stratovolcano, although it may be within the flank of the old volcanic edifice.

The areas of mineralization comprise a total of 4.7 square kilometers of hydrothermally altered rock, generally containing 5 to 10 percent total sulfide. Traces of copper mineralization were seen in many places, but significant mineralization is hard to identify because of pervasive thorough leaching of the rocks near the surface. Most of the rock in the mineralized areas is quartz feldspar porphyry, but some is probably tuff and sandstone or tuffaceous sandstone. Alteration is silicic and sericitic and locally argillic. The sulfide was present as disseminated grains in part of the areas, now indicated by limonite stains and sulfide casts, and as abundant veinlets forming stockworks. Unleached sulfide at site 6-d, part disseminated and part in veinlets, is not as rare as at the other sites. Several places have traces of

oxidized minerals. Weathered sulfide and rather common copper carbonate stains were found at one locality. Analysis of one sample of the fresh rock showed 0.3 percent copper. Jarositic and gypsum-rich soils, in which the sulfate has been derived from the weathering of sulfides, are common at all sites.

These mineralized areas of the porphyry copper type have the potential of being important deposits; but only through evaluation, including exploration drilling, can it be determined whether they are exploitable ore bodies.

SUMMARY

Visual evaluation of false-color composites and a relatively simple method of digital classification were tested as aids to mineral exploration by using areas of known hydrothermal alteration and mineralized and altered intrusive stock as control areas. Both methods are shown to be useful exploration tools, and greatest advantage is probably gained by using them together. The simple classification method was applied to evaluate

2100 square kilometers of area regarded as having a high potential for deposits of the porphyry copper type, leading to the discovery of five sizable areas of hydrothermally altered rock containing abundant sulfide, disseminated or in stockwork veins. Although the classification method used was relatively simple and unrefined, and 14 prospecting targets proved to be false leads, the number of sulfide-bearing areas identified was outstanding, and the falsely classified areas were not so many as to require an unreasonable amount of field checking. Further experimentation indicates that better discrimination of mineralized areas than we used in the field test can be achieved. The study indicates that simple methods of digital classification of Landsat data can be an important supplement to standard methods of mineral exploration, especially in desert terrains.

ACKNOWLEDGMENTS

The original color composite experiment conducted by the U.S. Geological Survey was partly supported by the National Aeronautics and Space Administration. Financial support for the digital-processing experiment and for the travel expenses of the field checking was provided by the Earth Resources Observation Systems (EROS) Office, and logistical support in the field was furnished by the Resource Development Corporation, a Pakistan Government corporation. The authors gratefully acknowledge the contribution of Jon D. Dykstra, Department of Earth Sciences, Dartmouth College, who performed in 1975 the extraction of

reflectance data for the Saindak area and for various sites in the application area.

REFERENCES

1. Schmidt, Robert G.: The Use of ERTS-1 Images in the Search for Large Sulfide Deposits in the Chagai District, Pakistan. Final Report. U.S. Dept. of Commerce, Nat. Tech. Inf. Service, E74-10726, 1974.
2. Ahmed, Waheeduddin; Khan, Shahid Noor; and Schmidt, Robert G.: Geology and Copper Mineralization of the Saindak Quadrangle, Chagai District, West Pakistan. U.S. Geol. Survey Prof. Paper 716-A, 1972.
3. Hunting Survey Corporation, Ltd.: Reconnaissance Geology of Part of West Pakistan; a Colombo Plan Cooperative Project. Report published by Government of Canada for the Government of Pakistan, Toronto, Canada, 1960.
4. Lowell, J. D.; and Guilbert, J. M.: Lateral and Vertical Alteration-Mineralization Zoning in Porphyry Ore Deposits. *Econ. Geology*, vol. 65, no. 4, 1970, pp. 373-408.
5. Bernstein, Ralph: Scene Correction (Precision Processing) of ERTS Sensor Data Using Digital Image Processing Techniques. Third Earth Resources Technology Satellite-1 Symposium, vol. 1, NASA SP-351, 1974, pp. 1909-1928.
6. Khan, Shahid Noor: Interim Report on Copper Deposit of Saindak, Chagai District (Baluchistan), Pakistan. Pakistan Geol. Survey, Saindak Copper Report No. 1, 1972.

INFORMATION/ USER SERVICES

Summary

David Landgrebe^a

The information systems and user services sessions were organized with the intent to display the current technology to the potential user community. As a result, rather than reporting primarily new research results which will ultimately become new technology available to the user community, the papers described various aspects of the technology which are available to users now.

Papers presented which display this technology and how a potential user may gain access to it may be divided into the following categories:

- Data distribution: availability of and access to data
- Technology transfer: system use illustrations and availability of training
- Hardware systems descriptions: processing hardware constructed and available
- Data processing techniques: individual processing techniques
- Future developments: a sampling of future technology

These papers are summarized as follows.

DATA DISTRIBUTION

Three papers discussed aspects of data availability and distribution. Two papers dealt with the distribution of U.S.-collected data with emphasis on Landsat. One other reported on aspects of proposed new data distribution in Africa.

Two papers described data available from the United States Department of Agriculture (USDA) Aerial Photography Field Office (I-21, vol. I-B) and from the Earth Resources Observation Systems (EROS) Data Center (U-2, vol. II-B). Data available from these centers

were collected in the NASA Earth Resources Program as well as by the Departments of Agriculture and Interior.

Data distribution is proposed in Zaire and the surrounding area (I-14, vol. I-B). The activity in Zaire is staffed with a group of researchers who have been trained in remote sensing. Zaire is installing a ground receiving station which will be operational in 1976 and will provide data not only to Zaire but to 37 additional African countries. Zaire will become the principal remote-sensing training center for the African countries.

TECHNOLOGY TRANSFER

Six papers were presented discussing aspects of transferring technology from the research stage to the operational stage. These six papers may be categorized into four training and two application papers.

In "Remote Sensing as an Innovation: How Can We Improve Its Rate of Adoption?" (I-15, vol. I-B), the author reviewed concepts of technology transfer. He suggested that a user would apply at least the five following basic criteria to a new technology before adopting it in his operational system. These need to be taken into consideration by the developers of remote-sensing technology.

- Relative advantage
- Compatibility
- Complexity
- Trial utility
- User reliability

The implementation and results of an extensive training program for many agencies in the State of Texas on remote-sensing technology were described (I-22, vol. I-B). The need for training programs was emphasized,

^aLaboratory for Applications of Remote Sensing, West Lafayette, Indiana.

and the author reported results of the various agencies' decisions to implement some remote-sensing technology into their operational programs.

Provided in paper U-3 (vol. II-B) are a list of available literature in the field, a list of ongoing remote-sensing symposia and conferences, and a list of ongoing intensive short courses and residence programs. The author discussed a remote terminal network, and implementation of analysis software as additional means by which to avail oneself of this technology. The intention of the paper was to present a survey and discussion of two components necessary for bringing the remote-sensing technology to the user community. These two components are education/training opportunities and the equipment (hardware/software) for analyzing the data available from today's sensor systems.

An educational tool was developed at the University of Nebraska for junior and senior high school students (I-8, vol. I-B). The author pointed out the importance of educating the youth in aspects of future technology and demonstrated tools available for this purpose.

Two papers showing application of remote-sensing technology were presented during the information systems and services session. The first (I-6, vol. I-B) discussed the mechanism by which remote-sensing technology is being used in the Forest Service. After defining the decisionmaking process, the author described an integrated information system that the USDA Forest Service and surface environmental and mining program are developing, which has substantially reduced the time it takes for collecting and processing data. Useful products are being generated from topographic analysis systems (TOPAS) and the computer program computer mapping for land use planning (COMLUP). Although the subsystems are limited at present, the role of an operational information system that will allow the user to simulate impacts on resources, predict responses, select alternatives, and make management decisions has been demonstrated.

"Geologic Analyses of Landsat-1 Multispectral Imagery of a Possible Power Site Employing Digital and Analog Image Processing" (I-12, vol. I-B) reported a study to determine lineaments and geological aspects of an area. Rather than replacing current manual methods, this study well illustrated the fact that new digital analysis systems can be a valuable tool in increasing the reliability of traditional means and verifying that linear patterns are correctly identified.

SYSTEM DESCRIPTIONS

A series of papers was presented describing the advances in automatic data processing and descriptions of typical data processing hardware available. Advances in automatic extraction of Earth resources information from multispectral scanners were described (I-10, vol. I-B) with the suggestion that the primary focuses of automatic processing are in preprocessing and extractive processing. The existing technology for automatic processing is in the transition phase going from feasibility to applications. Three major points to consider in such a transition are:

- Accuracy
- Cost effectiveness
- Speed

Systems descriptions were provided on data processing hardware currently in use for analyzing remotely sensed data. The systems described were the General Electric Image 100, JSC Screwworm Eradication Data System, Bendix Aerospace M-DAS, Earth Resources Laboratory low-cost data system, Jet Propulsion Laboratory multiple input land use system, ESL interactive digital image manipulation system, and Stanford Research Institute image animation. The capabilities of these systems range from image manipulation, registration, and classification to screwworm propagation and rainfall estimates. Each system had its unique functions and limitations. The main area of commonality in these systems was the use of a minicomputer which provides the user the capability of relatively low operation and maintenance cost with a high data processing throughput. All systems contain interactive capability providing the user the ability to manipulate, enhance, screen, train, et cetera, on the data prior to performing a detailed analysis.

The Image 100 (I-11, vol. I-B) is a system equipped with a PDP 1145 minicomputer and interactive display (fig. 1), which is capable of accepting inputs from computer-compatible tapes or film. The output products are photocopies, hard copies or CCT's. The I-100 has several preprocessing options built in the hardware such as: ratioing, color coordinate transformation, etc. There are over 40 applications software programs available for the I-100 ranging from training on the data to a level-slicing option for classification.

The screwworm eradication data system (I-13, vol. I-B) is also equipped with a PDP 1145 minicomputer and an interactive display (fig. 2). The inputs are limited to



Figure 1.— Image 100 system in use.

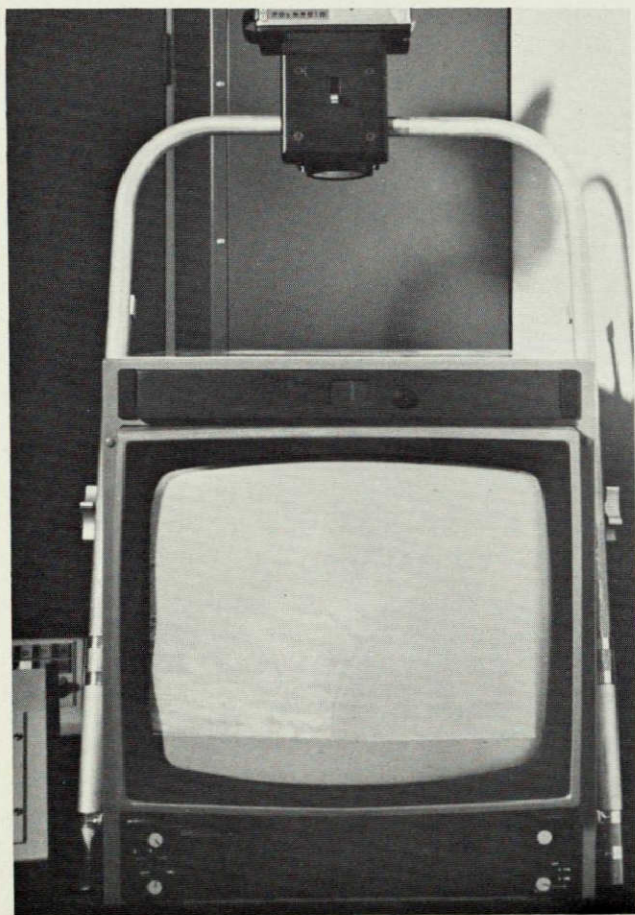

Figure 2.— JSC screwworm eradication data system interactive display.

14-track analog tapes or computer-compatible tapes. The outputs are images, color maps, and CCT's. A unique feature of the interactive system is that it can scroll left

to right, right to left, top to bottom, and bottom to top. The system is equipped with applications software for calibration, image handling and registration, rainfall algorithm, and screwworm propagation algorithm.

The mini data analysis system (M-DAS) is equipped with a PDP 1135 minicomputer and interactive display capability (fig. 3) (I-16, vol. I-B). The inputs are computer-compatible tapes, and the output products are film and CCT's. The interactive system provides the ability to manipulate, enhance, and to train on the data. This system has implemented the maximum-likelihood algorithm for classification and is considered a high-speed processor. One full Landsat frame (100 by 100 nautical miles) can be classified into 20 to 30 categories in 8 hours. This system has demonstrated repeatability by having different operators working the system and achieving the same results.

The basic hardware and software system requirements for some low-cost data analysis systems consisting of an image display system, small general purpose digital computer, and an output recording device were described (I-18, vol. I-B). The basic characteristics of these systems are that they are stand-alone systems, based on available, efficient and inexpensive components (fig. 4). The systems have modular components to provide needed flexibility in their application. These, characteristically, provide an image/interactive system for viewing data, training, and observing statistics; a computer for reformatting, signature determination, pattern recognition, information extraction, et cetera; and some system for output display of processed data.

A system which departed somewhat from the others described was one designed around an analog system used in television (I-24, vol. I-B). This system is very useful for time-lapse display and change detection. The television input system allows imagery and maps to be input for analysis directly without digitization.

The multiple input land use system (MILUS) is based on the use of a television raster scan device to input remotely sensed data as well as conventional maps into a geocoded system (I-20, vol. I-B). This system provides an ease of data entry and expandability and is automated to provide cost-effective implementation.

The interactive digital image manipulation system (IDIMS) (I-23, vol. I-B) is equipped with an HP 3000 computer and an interactive display. The system will accept inputs from images or computer-compatible tapes. Output products are CCT's, images, hard copies, et cetera. The design of this system is modular so that additional capabilities can be added or deleted based on user requirements. The system has many preprocessing and display functions available to the user such as

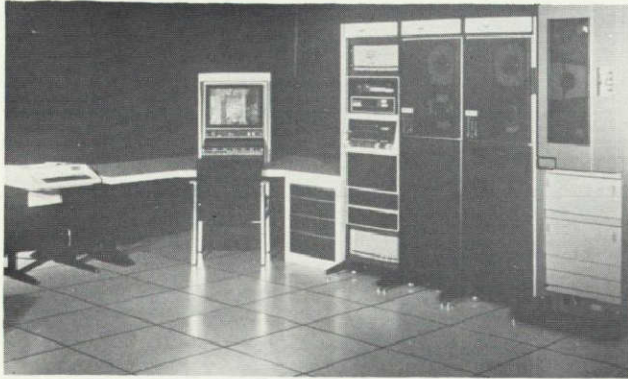

Figure 3.— M-DAS, which includes minicomputer and interactive display.

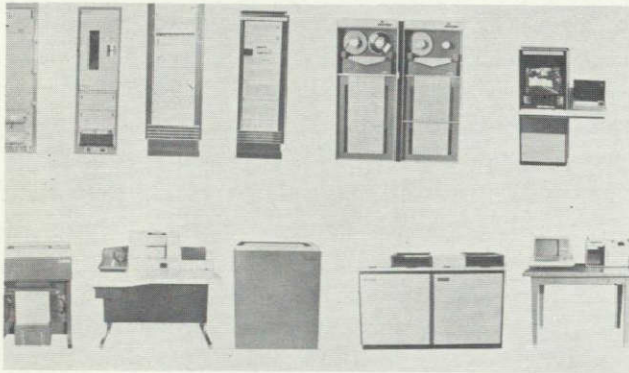

Figure 4.— Available components for use in low-cost data analysis systems.

arithmetic manipulations, Fourier operations, image transformations, and pseudocolor maps, which can be generated prior to detail processing. A unique feature of the applications functions is that the IDIMS has conventionally implemented maximum-likelihood and minimum-distance classifiers (fig. 5), and a third classifier implemented in a table look-up mode.

DATA PROCESSING TECHNIQUES

A number of papers in the information systems and services session dealt with data processing techniques, both those which are operational and ones which hold promise for improvements in data processing in the future.

The geometric correction and registration of Landsat data were shown to have operational application (I-3,

vol. I-B). Full scene registration of Landsat data to better than 0.5 picture element (root mean square) was obtained using all digital methods. The spatial registration of each picture element to a particular point of the Earth surface was visibly improved when a cubic convolution interpolation technique was used instead of the simpler nearest neighbor technique. The use of spatially registered satellite data extends the presently accepted advantages of digital processing techniques to the multitemporal as well as multispectral environment.

An unsupervised classification technique, which has been implemented on three systems in France (I-9, vol. I-B), uses a three-step procedure which first reduces the dimension of the raw data, then groups channels for classification. The final step is the use of an adaptive clustering algorithm based on a minimum-distance criterion for the assignment of the various spectra to a specific cluster. The results of classifying a Landsat-1 scene on the coast of France was stated as being very good.

A system for timber resource inventories (I-19, vol. I-B) was designed in the context of meeting the needs of the U.S. Forest Service in a cost-effective and timely manner through the use of remote-sensing data, ground data, and multistage sampling techniques. Given consideration to the capabilities and limitations of the user and the eventual operational use of the system, studies were performed to evaluate the use of both digital and photointerpretive techniques. Landsat digital data, high-altitude imagery, ground measurements, and equal-probability sampling of multiple parameters were used in performing a total timber resource inventory of the Plumas National Forest in California. Although a

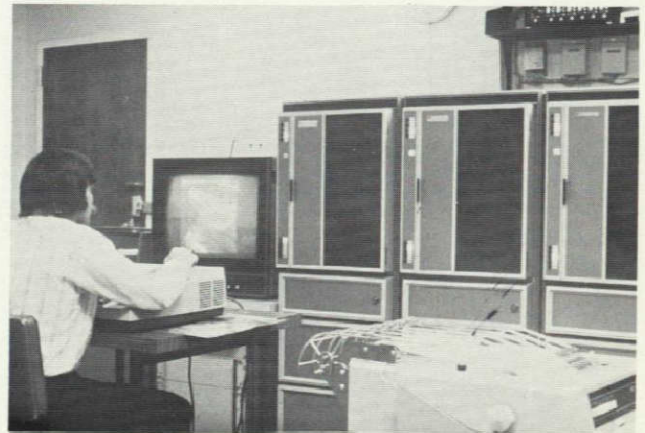

Figure 5.— Interactive digital image manipulation system in operation.

comparison with Forest Service results obtained by conventional means was difficult, a relative standard error of less than 8.0 percent was achieved for most parameters of major interest at about half the cost of the conventional approach. An evaluation of the use of Skylab S190 imagery and manual interpretive methods of obtaining timber volume information is awaiting final results. This approach is intended to demonstrate a timely, cost-effective method of obtaining timber volume information that does not require the use of a computer.

The promise of future improvements in processing capabilities was also presented. These included a classifier which shows potential for increased applications, lower costs, and increased extraction of information. A layered classification technique was described (I-1, vol. I-B), which provides a means of maximizing classification accuracy and efficiency by optimizing the number and selection of features used in each decision. The efficiency in the layered classification process is gained through the fact that many of the decisions involve a small number of features. Accuracy is gained by using an optimal subset of features for each decision. Several of the diverse applications to which this approach is well suited were discussed.

Another classification technique which has shown improved efficiency and accuracy (I-2, vol. I-B) uses mixtures of classes along with pure classes as training data. By this method, classification of Landsat-1 data over the Cripple Creek, Colorado, area improved over a classification using nonmixture statistics. This technique may prove valuable in areas where vegetation masks the characteristic spectral response of underlying geologic material or in other similar situations where the terrain features generally are small compared to the ground size of a scanner picture element. Calculations were presented which used in-scene calibration targets from which path radiance and transmittance were derived. Large homogeneous sites, such as a large lake, dense forest, desert sand, or a dry lake bed, can be used in this technique as natural calibration panels on the ground. The calculated path radiance and transmittance were determined using the in-scene calibration technique for Landsat and Skylab data. The radiometric accuracy

obtained for spectral data in the visible bands was reported to be within 5 to 10 percent of ground measurements and 20 to 30 percent for infrared bands.

A comparison of four different atmospheric models using Skylab S191 and S192 data was presented (I-4, vol. I-B). The infrared and solar transmission and absorption properties within the atmosphere as observed in the satellite data were compared with the results of the four models. A number of strengths and weaknesses in the various models were identified. The positive aspects of each of these models may be combined to provide a model in the future which better describes the effect of the atmosphere on satellite data.

A unique and inventive investigation used solar reflections from small, transportable mirrors to generate uniquely identifiable landmarks in Landsat imagery (I-5, vol. I-B). Using a mirror a few feet in diameter, positioned to $\pm 0.1^\circ$ pointing accuracy, and knowing the time and location of satellite passage to standard ephemeris accuracies, the investigator obtained clearly discernible signals on all four bands of Landsat imagery. Many applications, such as measuring system response, determining site location, geodetic control and others, are possible using the simple and inexpensive technique.

SUMMARY

These papers provide convincing evidence that the initial layer of a new technology is ready for the user community. Data are available and are indeed being delivered on a reliable and routine basis. Training programs by which users can be and are being trained are available on flexible bases to meet nearly any user's needs. Both special purpose hardware and software are now offered, much of it developed with private capital and demonstrated to be practical and cost effective; examples of these were described.

And finally, there was ample indication of continued future development of this technology so that the potential user may be reasonably assured that whatever is available and practical today will be even more so in the years ahead.

LAND USE/ STATE AND LOCAL USERS

Summary

Charles M. Parrish, III^a

The primary objective of our session was to illustrate and compare alternative approaches to remote-sensing applications in state and local resource management problems. We felt that our session would be successful if we could learn something that we could apply in our local situations on a cost-effective basis in the relatively near future, and if we could develop a consensus on how NASA and other Federal agencies could make their programs more effective and more useful to the decisionmakers.

It was not surprising that remotely sensed data are currently being applied to many management problems. The papers dealt with some of the more complex approaches, simply because those are the ones that people felt that it was appropriate to come and talk about. I will try to give a few illustrative examples of what we heard.

In East Tennessee, the Tennessee Valley Authority (S-7, vol. II-B) developed a timber management analysis from a combination of slope, derived from soils maps, and forest type, derived from low-altitude photography.

Wildlife habitat mapping from Landsat digital data was done for Alaska. The map resulted from a digital classification dealing with the density of the forest types. This information was used in the native claims selection in that part of northwestern Alaska (S-6, vol. II-B).

A flood area was overlaid on land use done by the State Planning Office of Louisiana (S-8, vol. II-B). Landsat imagery was used to show the extent of the flooding during the spring of 1975 in Louisiana, and the land use data were produced by the land use and data analysis (LUDA) program.

Urban expansion was monitored in Arizona (S-5, vol. II-B), both by low-altitude and by Skylab photography,

indicating how clearly you can examine land use changes from that platform.

A paper from Georgia (L-2, vol. I-C) covered the use of Landsat digital data and computer techniques to delineate marsh vegetation. In particular, the dark red and lighter orange in figures 1 and 2 show two very distinct species of marshland vegetation in the coastal Georgia area; these are important in determining the productivity effects of any kind of management changes in the marsh.

Though not purely operational and feasible at this time, the application results shown in figures 3 and 4 are among the most interesting, and, in the long term, possibly some of the most important. Figure 3 shows a ground-level photograph of a village in Niger. Figure 4



Figure 1.— An example of coastal area mapping by use of satellite digital data.

^aGeorgia Department of Natural Resources, Atlanta, Georgia.



Figure 2.— The same area as shown in figure 1. The dark reds delineate specific types of marsh vegetation.

shows the village and the area's distribution from a computer-implemented classification of digital data (L-20, vol. I-C). The light specks across figure 4, going diagonally across the figure, are along the major river. One of those is the village that was used as a training sample. Across the left, you see more dispersed habitations along the small tributary. In the middle on the bottom left, you see a dispersed agricultural seasonal habitation. As was pointed out in the paper, we are looking at the type of habitation which characterizes 25 percent of the world's population. Only half of us are in urbanized areas. The rest are rural, and of those in the rural areas, 50 percent are in relatively compact, though small, habitation areas.

Other significant applications we heard about were corridor location analysis in the construction of



Figure 3.— An African village scene.

highways and utility lines, and applications considering different types of hydrological modeling and analyses (surface water runoff, urban runoff, sedimentation, and surface water volume).

Mr. Mathews told me that my real mission was to highlight some of the problems which we ought to be addressing. Whenever possible, I shall try to indicate a direction which should be considered for future program development.

First, and it will not surprise anybody here, there is a tremendous gap between the technical development and the managerial application of the information. The NASA and other Federal agencies, as well as state agencies, are becoming much more conscious of the user and his needs. But I guess we're saying, "Don't stop now." Educational programs should be a top priority. When you're dealing with a local user, unless you can take him from the first step to last step and show him exactly what his product is going to be, he's just not going to be able to accept it. It will be too risky. Also, formalized education programs, those sponsored and developed by the Federal agencies and made available as an extension or technical service to state and local governments, are extremely important. Research projects as funded should emphasize the involvement of students who one day will be managers, trying to apply these techniques, as well as trying to develop new data.

Do not neglect the simple technique. We quite often go for the sophisticated when there may well be a tried and proved way that works just as well. More complex approaches should be applied only as they are proved and the management problem requires their application.

As much to educate the user as to improve the solutions, the intended user should participate in the design of the data acquisition and handling systems. If the user works on the development and understands the nuts and bolts, he will be able to go back and use it.

Second, we would like to say that the user must have confidence in an operational system with a guaranteed continuity of service. Many of us are using the data from Landsat in routine manner now, but we must recognize that the system is not classified as operational and, therefore, any large commitments made to training, technology, and equipment are very risky. We are still hearing a lot about things that are under development. If we concentrate on what we know Landsat will do and evaluate that in relation to specific problems, I think we will recognize that Landsat ought to be an operational system.

Third, we must recognize that no one system is ever going to be a panacea. We need a collection of tools suited to the particular problems which we are going to

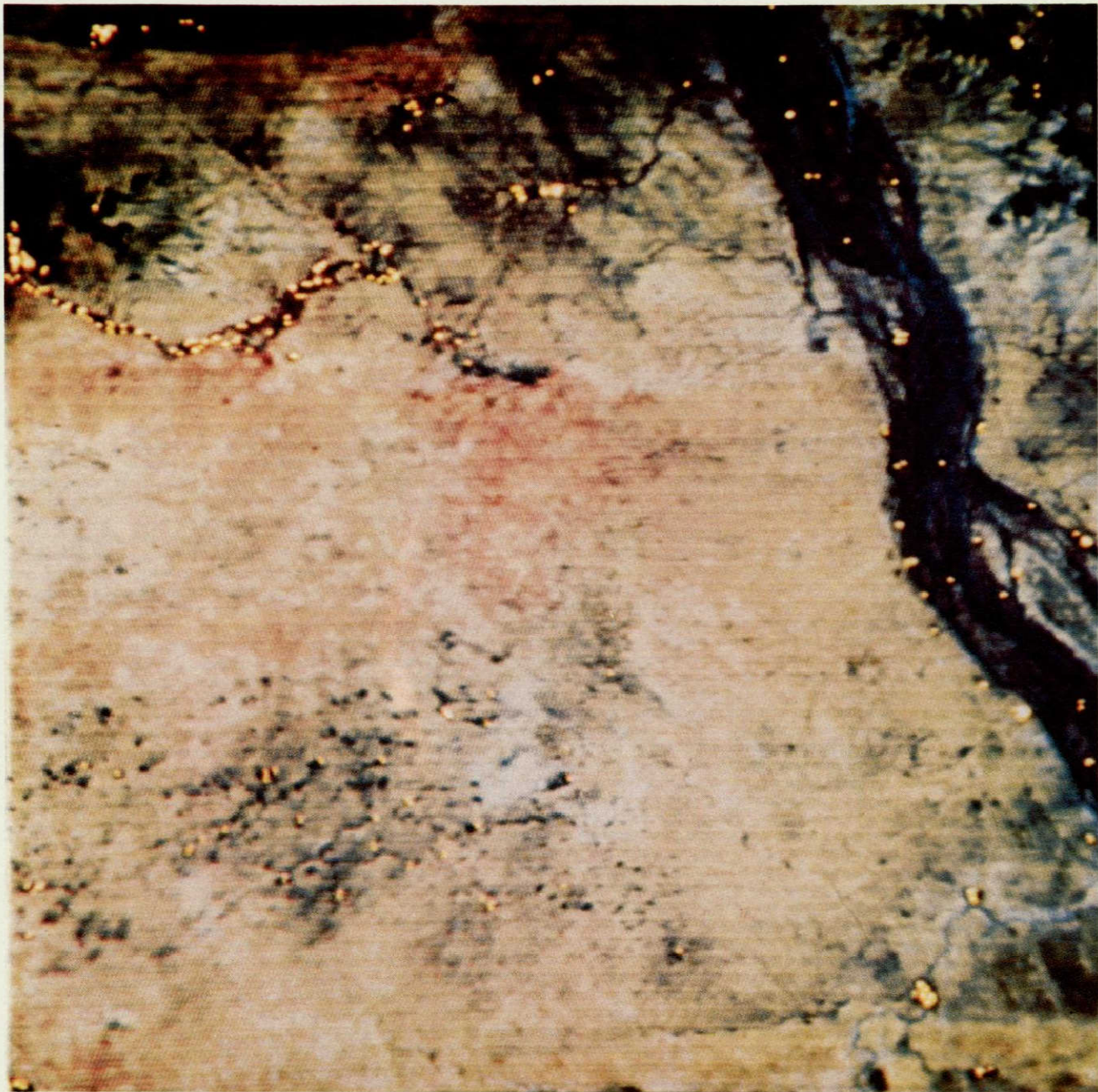

Figure 4.— Bright yellow dots pinpoint individual villages like the one in figure 3 on this computer classification with Landsat digital data.

deal with as managers. We will long need combinations such as spacecraft and aircraft, digital and optical.

Fourth, it is very important to recognize that we must have data provided to the users in registered form, with reasonably accurate references in data points to the ground. Users now have to invest a lot of money and manpower which would no longer be needed if we could

get already registered data in volume output from the Federal Government.

Fifth, we need to develop cooperative programs. If states share the cost, the chances are that the data will be worth collecting, and the states will have more involvement in how it is collected and what format is used.

Sixth, we need more personal communication between the suppliers of data and the users, and among the users themselves. We need to develop a consensus approach to management. In our session, there was actually only minimal involvement and attendance from local governments. We were much more heavily represented at the state level, and I think it is very easy for us to forget that probably most of the time, the actual manager who will make the decision is with the local and not the state government.

Seventh, we must get users involved in helping develop the future programs. This relates to education, and it also relates to improving the program; but we must have a structured effort by the Federal Government to involve them. I think this conference has gone a long

way. You have made other efforts in recent months and years. They must be continued. We also, of course, did recognize that the state and local governments, the ultimate users, share the responsibility of defining our own needs and expressing them to the Federal Government, thereby aiding you in the development of your programs.

Though we identified many of the basic problems which need to be resolved in developing future programs, nothing should prevent us from using the data now available and applying it to management needs in a basic way which will go far towards solving our problems today. Users must work together in a structured, focused, and intensive manner to develop definitions of what the program needs are for the future.

Present and Potential Land Use Mapping in Mexico*

Héctor Garduño,^a Ricardo García-Lagos,^b and Fernando García-Simo^c

INTRODUCTION

By the end of 1972, the Mexican Water Plan (MWP) started working with its main objective of developing systematic water resources planning procedures for the country. The Mexican Government made an agreement with the United Nations Development Program (UNDP) to make use of foreign expertise when needed. At the same time, a commitment was made to share the MWP's experiences with other countries. One-fourth of the \$4-million project was provided by the United Nations (UN) and the balance by the Mexican Government. The World Bank was the executing agency for the UNDP funds, providing assistance in selecting and hiring foreign experts.

In Mexico, agriculture is by far the largest water-consuming activity. Water resources planning is thus carried out within a physical framework in which the two most important resources are water and soil. This physical framework strongly interacts with a comprehensive socioeconomic framework during the planning process.

METHODS

Figure 1 shows the stages of the Mexican soil studies using Landsat satellite imagery. The MWP defined a work program for a 33-month project, which included soil inventories as one of the main inputs. Water requirements for irrigated agriculture account for more than 95 percent of the country's total water consumption. Therefore, good soil inventories are as

important as water inventories for successful water resources planning.

When the MWP project was started, only the Food and Agriculture Organization (FAO) soils map for the entire country was available, together with many local

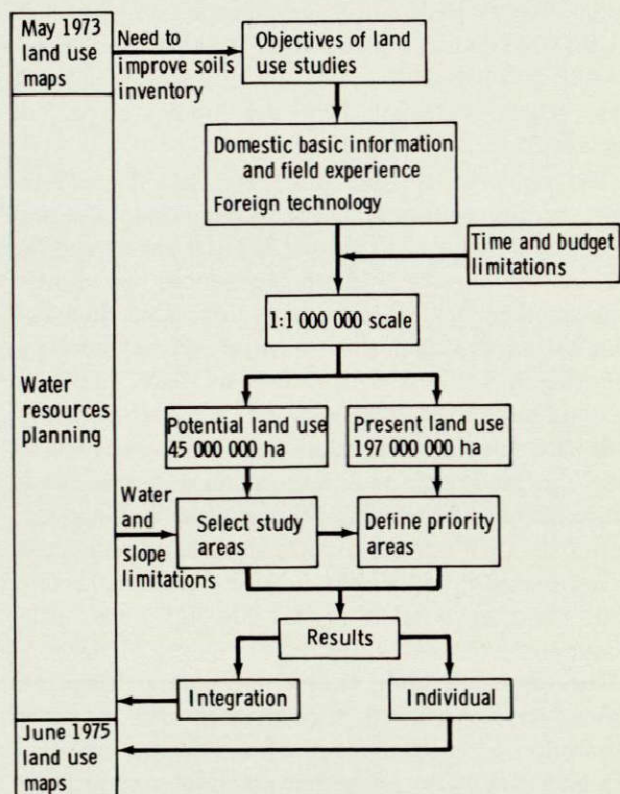

Figure 1.— Stages of Mexican soil studies as an input to water resources planning.

*Based on paper L-22 (vol. I-C).

^aMexican Water Plan, Secretaria de Recursos Hidráulicos, Mexico City, D.F.

^bMexican Water Plan, Mexico City, D.F.

^cIngeniería y Procesamiento Electronico, S.A., Mexico City, D.F.

soil studies covering small areas. Good 1:50 000-scale maps for present land use and potential land use are being developed in Mexico by the Comision de Estudios del Territorio Nacional (CETENAL). Unfortunately, the FAO soils map is too general and is not suitable for water resources planning. On the other hand, CETENAL maps are excellent, although, at the present time, they show less than a third of the entire country.

The MWP staff defined the objectives for the present and potential land studies and sketched preliminary procedures. Afterwards, two seminars were conducted in Mexico City to define the final procedures and to study present and potential land use by using Landsat-1 imagery (ref. 1). An experienced U.S. Soil Conservation Service scientist and two U.S. experts in Landsat imagery were selected to participate in the seminars.

A short training course on image interpretation for present land use purposes was then given by one of the remote-sensing experts, and a Mexican consulting firm conducted the study on present land use. In a 2-year period, the entire country was mapped at a scale of 1:1 000 000 and with a cost of \$200 000 (U.S. dollars); i.e., 0.1 cent per hectare. First priority was given to the areas where potential land use studies would be conducted.

The potential land use study was started 6 months later, because information on present land use was needed as an input. The second Landsat expert and the soil scientist, together with an experienced soil scientist from another Mexican consulting firm, supervised two pilot studies while adjusting the proposed methodology. The two U.S. investigators made six 1-week trips to Mexico during the following year to conduct the study. With each trip, they functioned more as a review team with the leadership and responsibility of the study turned over to the Mexican soil scientists. Within a year, more than a fifth of the country was studied with a cost of approximately \$150 000; i.e., 0.33 cent per hectare. Also, maps at a scale of 1:1 000 000 were finally produced.

The results of both present and potential land use studies have improved the Mexican soil resources inventories as a byproduct of the water resources planning itself. The integration of results contributed significantly to improvement of the regional water resources planning process.

A summary of results of both studies, as well as their integration, is presented. Finally, to accomplish the commitment with the UN, an outline of a step-by-step handbook to make land use studies using Landsat imagery, presently under preparation, is submitted for

discussion. Suggestions will help MWP in making a useful contribution to the field of remote-sensing technology.

PRESENT LAND USE STUDY

The objectives of the present land use study were

1. To survey present land use in the entire country (Special emphasis was placed on irrigated agricultural land and on rainfed areas.)

2. To provide basic information to determine potential land use and to compare later the results of present and potential land use studies

False-color infrared transparencies, made from Landsat bands 4, 5, and 7, were used. To interpret the 200 images that cover the country, the Level I recommendations of the U.S. Geological Survey (USGS) (ref. 2) were followed with slight modifications. Images taken during the dry and rainy seasons were used because agricultural land was the main interest of the study. This procedure made it possible to discriminate between irrigated and rainfed agriculture.

The project included intensive low-altitude flights and ground-truth trips, together with a comparison with detailed 1:50 000-scale CETENAL maps. Table I shows the reliability for each present land use that was mapped.

In the southeastern tropical part of Mexico, Skylab color-infrared photographs were used where cloud-free Landsat images were not available. Because only visual interpretation techniques were used, those areas that were densely covered by vegetation were especially difficult to interpret. Future efforts will also use methods that take advantage of spectral computer-aided scanning.

Results

The final results are now being printed in 17 land use charts that have a scale of 1:1 000 000 (fig. 2). Each map includes a detailed description for each land use, which takes into account the regional differences found in the country. A grid formed by squares of 0.5° latitude and 0.5° longitude was superimposed onto the maps; and supporting statistics of the area were calculated for each land use type on the basis of state, MWP regions, and individual charts. The area of each land use classification and the amount (in hectares) of advanced erosion was also computed. Figure 3 is a generalized map of the final results for the entire country.

TABLE I.- RELIABILITY OF THE RESULTS FOR THE PRESENT LAND USE STUDY

Land use (a)	Code	Minimum mapping unit, ha	More common mixed interpretations (b)	Reliability, percent
Irrigated cropland	1	50	2 and 3	95
Flat rainfed cropland	2	100	1 and 3	90
Steep rainfed cropland	3	150	1 and 2	85
Range and grassland	4	250	3 and 7	85
Woodland (conifer and hardwood)	5	250	6 and 7	90
Tropical forestland	6	250	5 and 7	85
Shrub/scrub land	7	250	5 and 6	85
Barren land	8	300	4	85
Wetland	9	200	1	95
Water bodies ^c	a	50		98
Urban areas ^c	u	100		95
Erosion	e	300		85
Average				90

^aThe two land uses more intensively field-checked were irrigated and rainfed land.

^bAccording to code numbers.

^cWater bodies and urban areas were easily identified.

Comparison with census figures is usually meaningless because of differences in land use definitions; however, whereas census data indicated that an area of 30 000 000 hectares is completely eroded, the present land use study detected only 6 300 000 hectares with advanced erosion.

cost of \$200 000 does not include expenses of aircraft checking or use of foreign personnel.

POTENTIAL LAND USE STUDY

Description

Duration, Manpower, and Cost

Figure 4 shows the schedule of activities for the present land use study. Once the procedure was defined and the image interpreters were trained, a set of straightforward steps was followed for each of the 17 land use charts. However, a major change was made in the original methodology when ground truth proved to need a far greater effort than was at first anticipated.

Table II shows the manpower used in the study, and table III gives a breakdown of costs for the entire study that covered 197 000 000 hectares. The reported total

The objective of the potential land use study was to assess, at an identification level and not at a project level, areas with high, medium, or low agriculture and pasture productivity and water erosion risk.

Because the project was also concerned with the development of methodology to be used, two pilot studies covering 6 000 000 hectares were first conducted in a semiarid area and in a humid tropical area. The area covered was of reasonable size, and the ecological conditions were sufficiently varied to assure that the same methodology could be successfully applied in other regions of the country.

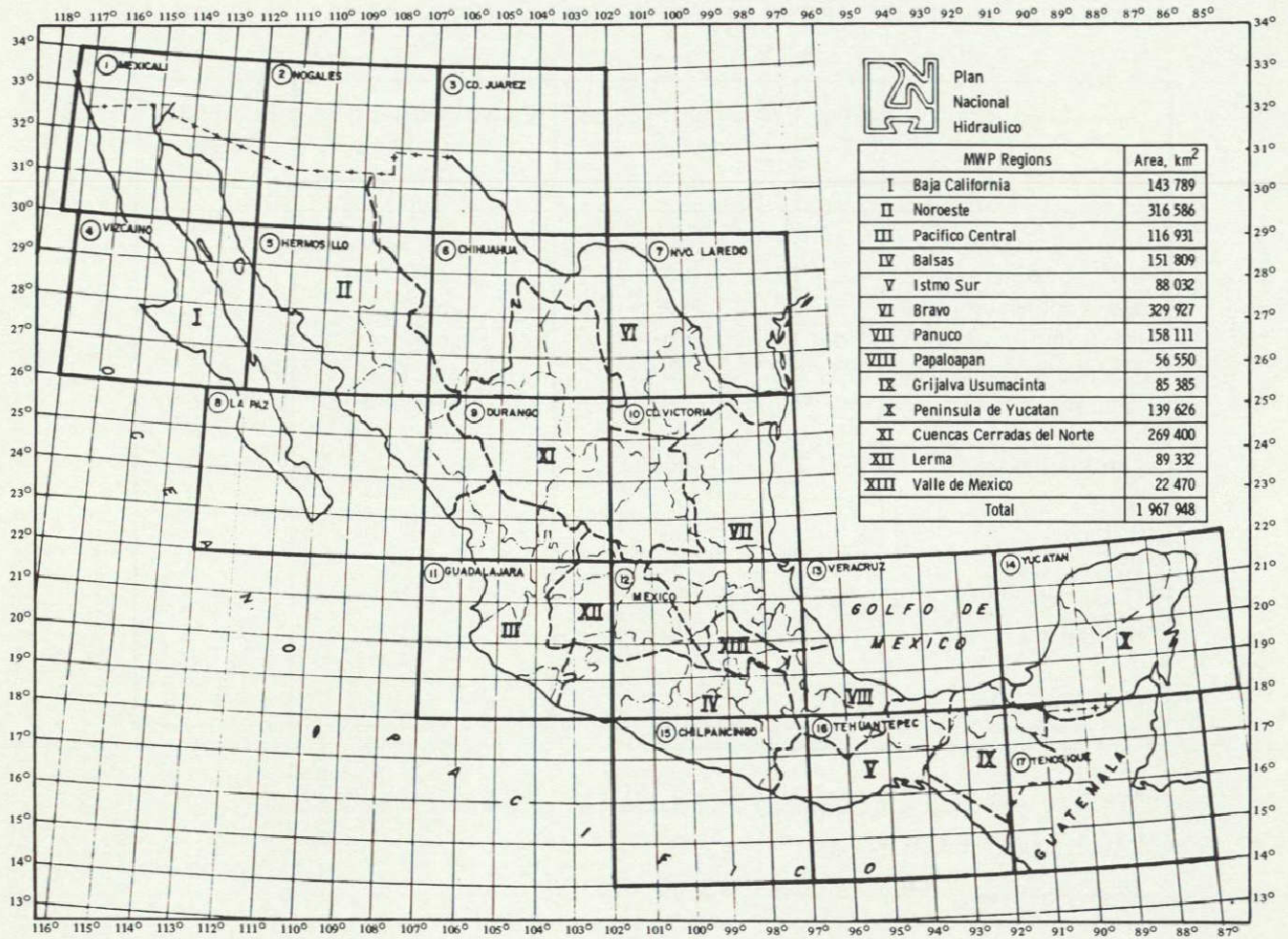

Figure 2.— Distribution of charts for the present land use study.

Interpretation of infrared false-color and channel 5 images was made by using transparencies and prints, both at 1:1 000 000 and 1:500 000 scales, although final results were produced at 1:1 000 000 scale. Overlays with general delineations of present land use maps, geology, rainfall, FAO soil units, and infrastructure were used for image interpretation. Also, more reconnaissance low-altitude flights and ground-truth trips using more intensive sampling were necessary in this study than in the present land use study.

The soil units classification was taken from the 1:2 000 000-scale FAO map, but a far more detailed soil units map was produced after interpreting the images with the aid of the overlays previously mentioned and with information gathered by the low-altitude flights and ground truth. The potential land use classification was made according to Handbook 210 of the U.S. Soil Conservation Service (ref. 3).

Finally, interpretive maps were produced for agriculture and pasture use, slope classification, and water erosion risk. A reliability of 80 to 90 percent was determined by comparing results of the study against available and more detailed results of other conventional soil surveys.

Results

Figure 5 shows the soil unit delineations obtained by following the FAO soil classification system. Image interpretation was an important factor in defining more precisely the soil unit boundaries, and image interpretation produced more details than were shown on the original FAO map.

Potential land use maps were prepared based on the properties of the FAO soil units, yield and production statistics, results from agriculture and livestock







	Land use	Area in thousand ha	Percent of total territory
	Irrigated cropland	4 178. 91	2. 12
	Flat rainfed cropland	18 050. 14	9. 17
	Steep rainfed cropland	9 935. 88	5. 05
	Range and grassland	12 290. 50	6. 24
	Other uses (Woodland, tropical forest, shrubland)	98 470. 00	50. 07
	Cloud-covered	2 875. 36	1. 47
	Areas in process of study	50 913. 13	25. 88
	Total	196 713. 92	100. 00

Figure 3.— Present land use study in Mexico.

Activities	1973												1974												1975					
	Jan.	Feb.	Mar.	Apr.	May	June	July	Aug.	Sept.	Oct.	Nov.	Dec.	Jan.	Feb.	Mar.	Apr.	May	June	July	Aug.	Sept.	Oct.	Nov.	Dec.	Jan.	Feb.	Mar.	Apr.	May	June
Define procedures					■																									
Select and obtain images						■	■	■	■	■			■	■	■			■	■	■				■	■					
Train image interpreters									■																					
Cartographic support								■	■	■	■	■					■	■				■	■							
Image interpretation									■	■	■	■	■	■	■	■	■	■	■	■	■	■	■	■	■	■	■	■	■	
Aircraft checking and ground truth ^a													■	■	■	■	■	■	■	■	■	■	■	■	■	■	■	■	■	
Land use area estimation													■	■	■	■	■	■	■	■	■	■	■	■	■	■	■	■	■	
Land use charts preparation													■	■	■	■	■	■	■	■	■	■	■	■	■	■	■	■	■	
Technical report for each land use chart													■	■	■	■	■	■	■	■	■	■	■	■	■	■	■	■	■	
Final report																												■	■	

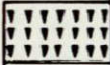
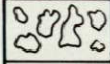
^aA total distance of 13 500 km was covered by airplane. Ground truth covered 12 500 km, sampling 4000 points.

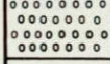
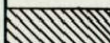
Figure 4.— Schedule of activities in the present land use study.

experiment stations, field observations, and personal experience of the soil scientists who conducted the study. Estimates of yields were made for the most important crops, together with evaluations of the grazing capacity for cattle feeding in each soil unit. Figure 6 shows the general results for agriculture productivity.

TABLE II.- MANPOWER REQUIRED FOR PRESENT LAND USE STUDY

Classification	Manpower, man-months
Mexican personnel	
Project manager	26
MWP project coordinator	3
Image interpreters	112
Cartographic support assistants	29
Assistants for land use area estimation	90
Draftsmen	64
Total	324
Foreign personnel	
Remote-sensing expert	1

TABLE III.- COST BREAKDOWN OF PRESENT LAND USE STUDY

Item	Percentage of total
Image and photographic material	8
Image interpretation	35
Cartographic support	7
Ground truth	15
Land use area estimation	22
Drawing and reports	13

Only 17 000 000 hectares were found to have high and moderate agricultural potential productivity. This figure seems low when considering that the study was conducted in selected areas according to slope. However, large areas in the southeast were classified under present conditions as of low productivity because of seasonal flooding. With adequate flood protection and drainage measures, these areas could easily be considered as areas of high productivity, because the soils are deep, flat, and fertile.

The potential range and grass productivity was determined only for 29 700 000 hectares, because estimates of the grazing capacity per hectare were not

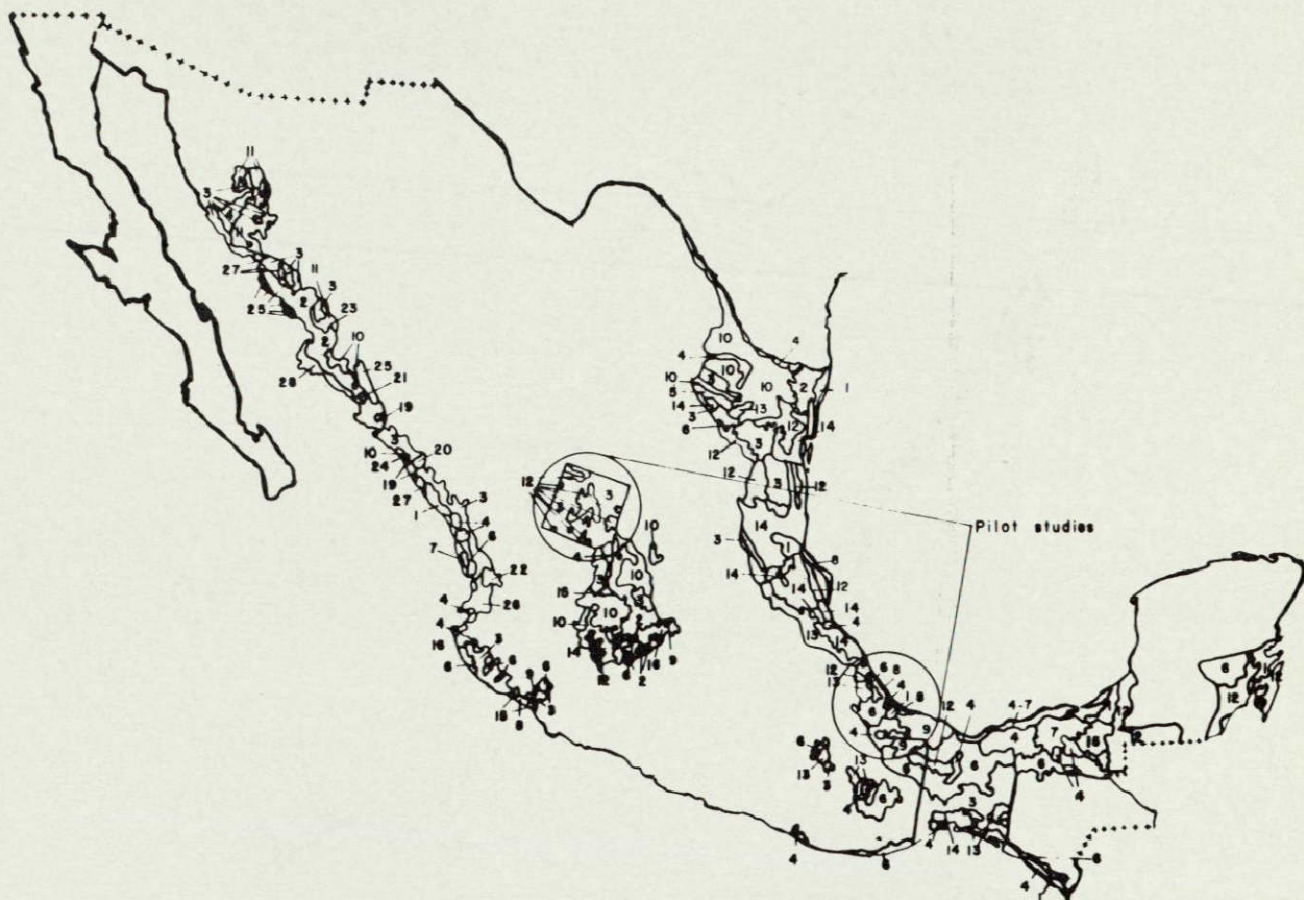

Great soil groups		Area in thousand ha	Percent
1	Gleysol	1 277.90	2.85
2	Phaeozem	4 109.4	9.18
3	Lithosol	8 337.7	18.63
4	Fluvisol	2 906.8	6.49
5	Castañozem	889.9	1.48
6	Luvisol	4 638.9	10.37
7	Histosol	1 056.9	2.31
8	Regosol	968.70	2.16
9	Andosol	552.3	1.23
10	Xerosol	4 489.5	12.03
11	Yermosol	755.6	1.63
12	Rendzina	4 330.2	9.11
13	Cambisol	1 943.5	4.34
14	Vertisol	4 380.3	9.24
15	Planosol	706.5	1.44

Great soil groups		Area in thousand ha	Percent
16	Solonchak	500.5	1.11
17	Xerosol-Lithosol (bc)	156.2	0.34
18	Phaeozem-Lithosol (3aa-Ib)	177.9	0.39
19	Phaeozem-Lithosol (3a-Ib)	177.0	0.39
20	Phaeozem-Lithosol (3a-Ic)	151.0	0.33
21	Phaeozem-Lithosol (2a-Ibc)	104.4	0.23
22	Phaeozem-Vertisol	134.6	0.30
23	Lithosol-Phaeozem (b-3a)	310.9	0.69
24	Lithosol-Phaeozem (c-3a)	225.0	0.50
25	Lithosol-Phaeozem (c-2b)	331.0	0.74
26	Lithosol-Luvisol	458.2	1.02
27	Fluvisol-Vertisol	57.0	0.12
28	Regosol-Solonchak	605.2	1.35
Total		44 733.2	100.00

Figure 5.— Preliminary results, showing great soil groups and associations, of the potential land use studies.

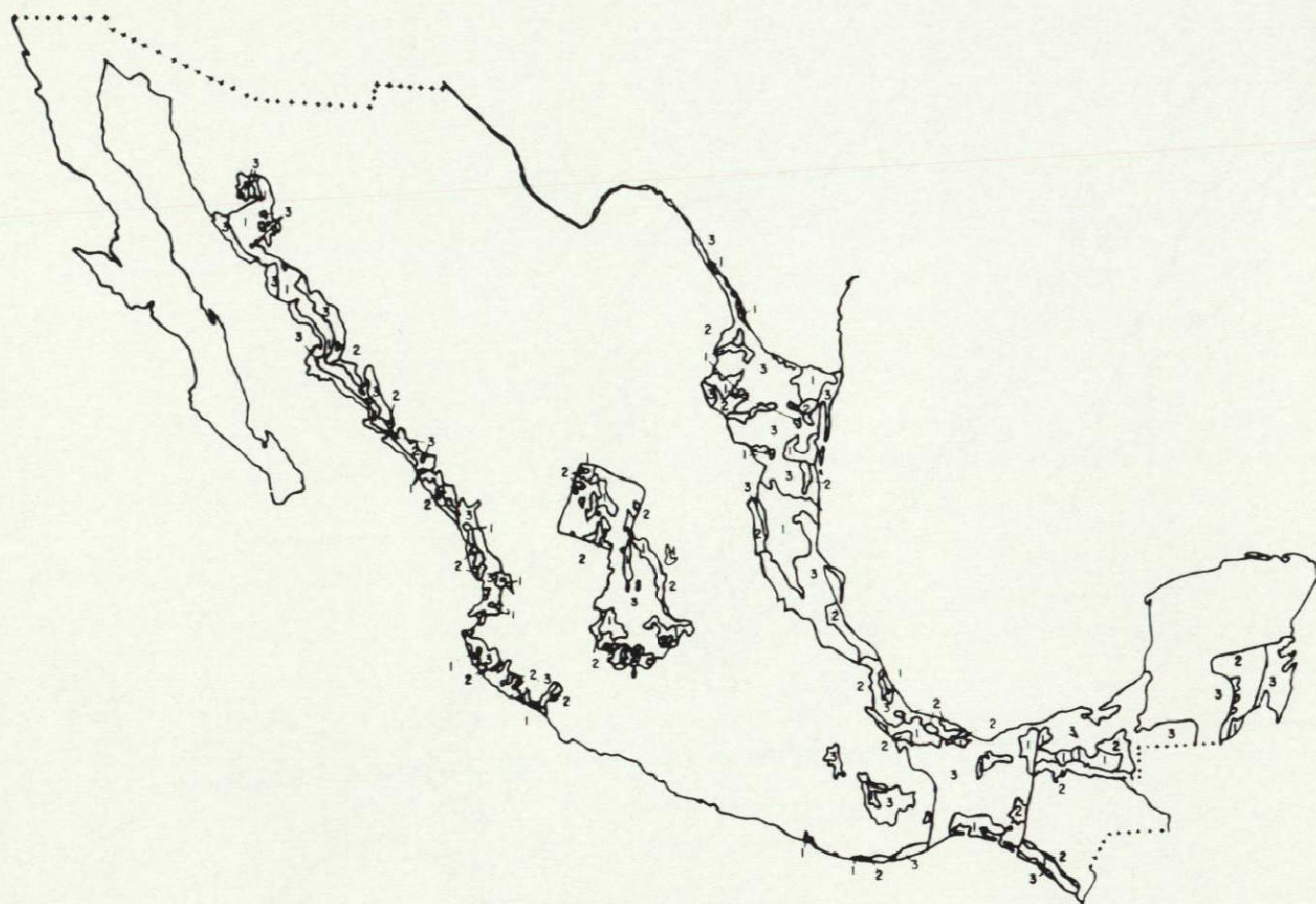

No.	Productivity rating	Area in thousand ha	Percent
1	High	11 118.8	24.85
2	Medium	6 275.0	14.04
3	Low	27 339.4	61.11
Total		44 733.2	100.00

Figure 6.— Potential soil productivity for agriculture.

available in the northwestern and central regions of the country. Figure 7 shows the general results. A large proportion of the area (23 000 000 hectares) was found to have from medium to high productivity. Most of the land is located in the gulf coastal plains and in the southeastern regions where most of the country's present-day livestock production is concentrated.

Finally, figure 8 shows areas with varying degrees of water erosion risk. Though the studied areas lie mostly on flatlands, 69 percent of the 45 000 000 hectares show medium-to-high water erosion risk, an indication of the need for sound soil-conservation programs and policies.

Duration, Manpower, and Cost

Figure 9 shows a schedule of activities for the study of potential land use. A line-production procedure was not feasible, and separate study packages were conducted in each selected area. The reason for this procedure was that integration of image interpretation, basic data, field notes, and personal experience must be considered to a greater extent by the soil scientist in finishing a study for a specific area. Therefore, each team had to finish its study of one area before undertaking a study of the next area. Two teams were responsible for the entire project.

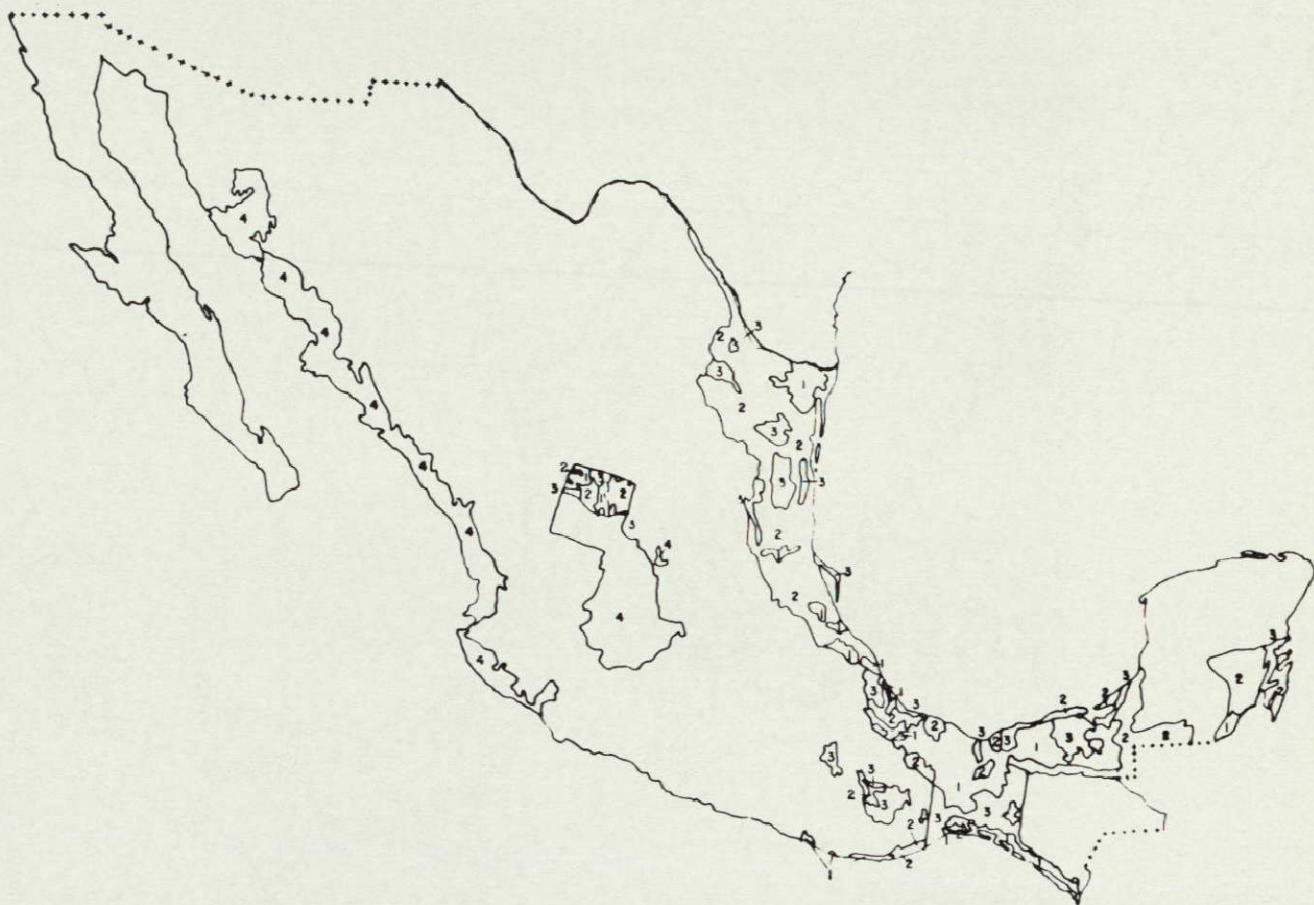

Productivity rating ^a	Area in thousand ha	Percent
1 High	6 989.9	23.52
2 Medium	15 839.8	53.31
3 Low	6 885.7	23.17
Total	29 715.4	100.00

^a Area 4 not rated.

Figure 7.— Potential soil productivity for grass.

Table IV shows the manpower used in the study, and table V shows a breakdown of costs for the entire study that covered 45 000 000 hectares. The reported total cost of \$150 000 does not include expenses of aircraft checking or use of foreign personnel.

THE ROLE OF LAND USE STUDIES IN WATER RESOURCES PLANNING

The comparison of potential and present land use maps shows that 82 percent of the total land now being farmed and rated as yielding high agricultural

productivity is being used at present with irrigated and rainfed flatland agriculture. However, there are 535 000 hectares of low-productivity areas that are presently being irrigated, and 3 600 000 hectares of the same productivity classification with rainfed agriculture. On the other hand, 3 900 000 hectares with high potential agricultural productivity remain unfarmed.

Forty-one percent of the 16 600 000 hectares presently being used within the studied area are in great danger of being eroded. Most of these areas have rainfed agriculture because most irrigated land lies in areas with low risk of erosion. This condition was expected, as well as the discovery that 15 600 000 hectares with

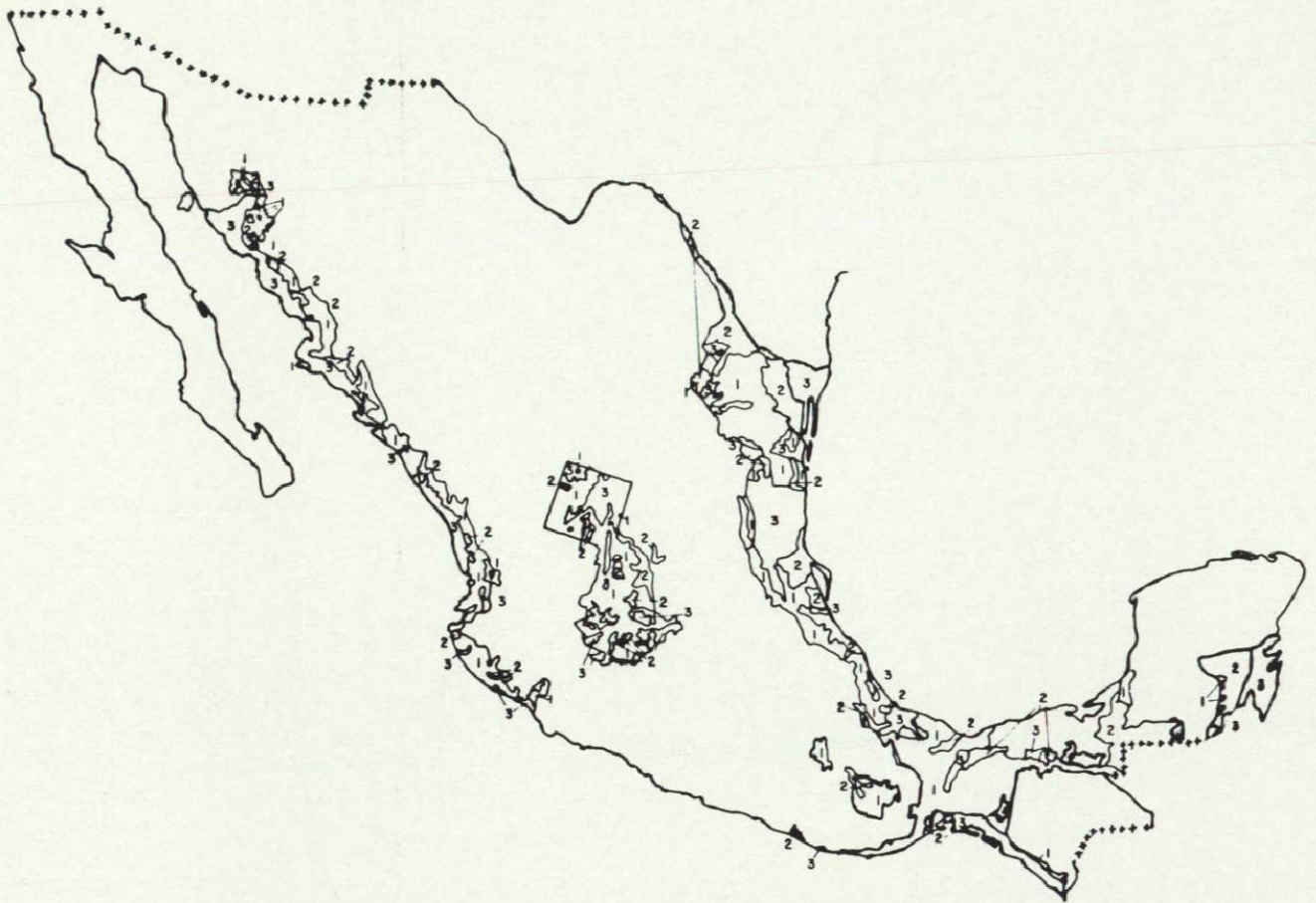

No.	Risk	Area in thousand ha	Percent
1	High	20 090.8	44.91
2	Medium	10 471.3	23.42
3	Low	14 171.1	31.67
Total		44 733.2	100.00

Figure 8.— Water erosion risk.

medium-to-high risk of water erosion are not being farmed.

There are large areas in the gulf coastal plains with low potential for agricultural productivity and medium-to-high risk of water erosion. These areas should be devoted mainly to pastureland, taking care not to overgraze them.

Detailed studies using these results are presently conducted at the MWP to define future regional water resources development related to agriculture, livestock, and soil conservation.

OUTLINE OF A SOILS HANDBOOK USING LANDSAT SATELLITE IMAGERY

The MWP soils group is preparing a handbook covering the points outlined in the following list. Comments and suggestions are welcome. For clarity, each step will be illustrated in detail with figures; and, in a general way, the results for the entire country will also be discussed in the handbook.

1. Introduction
2. Present land use

- a. Objectives
 - b. Classification criteria
 - c. Satellite image selection
 - d. Air reconnaissance and ground-truth trips
 - e. Interpretation adjustments
 - f. Land use area estimation
 - g. Reliability criteria
 - h. Cost estimates
 - i. Report writing and graphical presentation
3. Potential land use
- a. Objectives
 - b. Workteams
 - c. Image transparencies and prints
- d. Basic source overlays
 - e. Classification criteria for soil units and for land capability
 - f. Preliminary soil units delineation in the office
 - g. Air reconnaissance and ground-truth trips
 - h. Adjustments, final delineations, and maps
 - i. Reliability criteria
 - j. Cost estimates
 - k. Report writing and graphical presentation
4. Examples of interpretive maps developed
5. Integration of present and potential land use studies

		Jan.	Feb.	Mar.	Apr.	May	June	July	Aug.	Sept.	Oct.	Nov.	Dec.
I	Lower Papaloapan watershed												
	Image interpretation	▨											
	Aircraft and field checking	■											
	Final delineations and report		▨										
II	Central Zacatecas												
	Image interpretation		▨										
	Aircraft and field checking		■										
	Final delineations and report			▨									
III	Panuco watershed-northern Veracruz												
	Image interpretation			▨									
	Aircraft and field checking			■									
	Final delineations and report				▨								
IV	Tehuantepec Isthmus												
	Image interpretation				▨								
	Aircraft and field checking				■								
	Final delineations and report					▨							
V	Pacific Coast												
	Image interpretation						▨						
	Aircraft and field checking						■						
	Final delineations and report							▨					
VI	Northeast												
	Image interpretation							▨					
	Aircraft and field checking							■					
	Final delineations and report								▨				
VII	Southeast												
	Image interpretation									▨			
	Aircraft and field checking									■			
	Final delineations and report										▨		
VIII	Central Region												
	Image interpretation											▨	
	Aircraft and field checking											■	
	Final delineations and report												▨

Figure 9.— Schedule of activities for the potential land use study.

TABLE IV.- MANPOWER REQUIRED FOR POTENTIAL LAND USE STUDY

Classification	Manpower, man-months
Mexican personnel	
Team leaders (two)	22
Soil scientists (two)	22
Image interpreters (two)	22
Draftsmen (two)	20
Mexican Water Plan	2
Total	88
Foreign personnel	
Soil scientist	2
Remote-sensing expert	2
Total	4

TABLE V.- COST BREAKDOWN OF POTENTIAL LAND USE STUDY

Item	Percentage of total
Overlay material and image prints	2
Office work: preliminary delineation, source material analysis, and final integration to obtain soil unit maps and interpretive maps	56
Field reconnaissance trips	26
Drawing and reports	16

CONCLUSIONS

The use of Landsat imagery has made it possible for Mexico to obtain, in a 2-year period, land use inventory maps (1:1 000 000 scale) at an extremely low cost. The Agriculture Ministry is already conducting studies for land use inventory maps at a scale of 1:500 000.

The objectives of the present land use study were met, with an overall reliability of 90 percent. However, only a small fraction of the information contained in the images was used.

The next steps in using Landsat imagery in Mexico will include the study of dynamic changes in land use, computer-aided spectral scanning, more detailed studies in areas of interest at larger scales (1:250 000), et cetera.

The potential land use maps were developed faster and at a lower cost than would have been possible by using any of the conventional methods. A reliability of 90 percent was also accomplished in these studies.

The integration of both present and potential land use maps is extremely useful in providing orientations for regional development of water resources in agricultural countries with scarce water supplies. It also helps to set forth policies concerning land redistribution according to capability and water erosion risks.

ACKNOWLEDGMENTS

Messrs. Gerardo Cruickshank, undersecretary of planning at the Water Resources Ministry, and Fernando González Villarreal, general coordinator of the Mexican Water Plan, supported and oriented the land use studies. Dr. Donald Lauer, in charge of training programs at the Earth Resources Observation Systems (EROS) Data Center of the U.S. Geological Survey, helped in defining the present land use study methodology, trained the image interpreters, and made an appraisal of the final results. Dr. Albert Klingebiel, one of the experienced U.S. soil-conservation scientists who recently retired from the Soil Conservation Service, and Dr. Victor Myers, director of the Remote Sensing Institute at the University of South Dakota, helped in defining the potential land use study methodology and trained Mexican soil scientists in the field. (Both were also responsible for assistance during the air and field reconnaissance and for reviewing of manuscripts.) Roberto Vital of the MWP was in charge of preparing source material, map generalizations, and integration of present and potential land use. The EROS Data Center provided excellent service in processing and sending the images that were required for the study.

REFERENCES

1. Garduño, H.; García-Lagos, R.; García-Simo, F.; and Pérez-Gavilán, D.: Utilización de las Imágenes del Satellite ERTS-1 en la Planeación de los Recursos Hidráulicos. Primer Congreso Panamericano y Tercero Nacional de Fotogrametría, Fotointerpretación y Geodesia, México, 1974.
2. Anderson, James R.; Hardy, Ernest E.; and Roach, John T.: Land-Use Classification System for Use With Remote-Sensor Data. U.S. Geological Survey Circular 671, 1972.
3. Klingebiel, A. A.; and Montgomery, P. H.: Land Capability Classification. U.S. Department of Agriculture, Soil Conservation Service, Agriculture Handbook no. 210, 1973.

A Land Use Management Information System Implemented in Los Angeles*

Charles K. Paul^a

I would like to present from a planning point of view the coordinated efforts of NASA and the city of Los Angeles in undertaking the land use management information system (LUMIS) based on data content from remote-sensing imagery for directing land use issues in the Santa Monica Mountains. The Santa Monica Mountains are a 100-square-mile area within the city limits of Los Angeles (fig. 1). The issue regarding these mountains is a controversial land use item and the pressures between development and open-space recreation are very extreme, because 2.8 million people live in Los Angeles and approximately 8 to 9 million people live in the Los Angeles basin. The general plan for



Figure 1.— Landsat image of southern California.

Los Angeles (fig. 2) consists mainly of three subplans: the coastal plan in the Pacific Palisades region, an area of the Santa Monica Mountains; a seismic safety plan manifested by the little people about to fall in the crack; and an open-space plan to preserve the recreational area. We've tried to maintain the remote-sensing processing and information system concept that is compatible with the U.S. Census Bureau dual independent map encoding (DIME) file technology. In another report (S-12, vol. II-B), my colleague, Mr. Landini (a Los Angeles city planner), has advocated a joint endeavor in land use collection by the Census Bureau and NASA to provide information that can be quickly integrated with the type of socioeconomic data generally collected in our metropolitan areas. The flow chart of LUMIS, shown in figure 3, indicates how to do this. Various map sources, some produced by remote sensing, others provided by agencies, including the metropolitan map series, become the major polygons after digitization. All other types of maps are filed as minor polygons after digitization. The two are overlaid (by census block) in a polygon intersection overlay program to reference land uses derived from remote sensing as well as geology and other map sources. This overlay is done so that they can be readily integrated with census tapes, and with the Los Angeles County secured assessor file, and so that the city can daily generate environmental impact reports using the traditional computer line-printing techniques. The data are also integrated into an interactive graphics system (L-11, vol. I-C).

Now going through a sequence of events, as noted by Mr. Landini, tracing from the ground the land use patterns that develop in the Santa Monicas, I will indicate future possible sources of updating LUMIS by satellite imagery. Figure 4 shows a portion of the Santa

*Based on papers S-12 (vol. II-B) and L-11 (vol. I-C).

^aJet Propulsion Laboratory, Pasadena, California.



Figure 2.— The Santa Monica Mountain controversy.

Monica Mountains of Los Angeles. It is hard to believe that this pristine mountain range exists in the city limits of one of the largest metropolitan areas in the world. There is a perennial stream in the Malibu Canyon, and there are steep slopes in the Santa Monicas. The mountain range elevation in this area goes from sea level to approximately 2500 feet with some very, very steep slopes. These slopes, apparent in figure 4, are among the critical variables that make zoning so difficult.

South toward Santa Monica is an extremely urbanized area, the Santa Monica beaches. Along the beach is the famous commercial strip development we think originated in Los Angeles.

Figure 5, of the San Fernando Valley, shows the Pacific Coast highway in Santa Monica looking north toward Burbank and Verdugo Hill. To the north of the Santa Monica Mountains and the San Fernando Valley is a highly congested area and to the south encroaching on this mountain range are the communities of Hollywood, Bel Air, Brentwood, and Westwood. So, from two sides, this mountain area is being impacted very heavily by developmental pressures.

The pattern of land use development in these

mountains starts with a fire trail (fig. 6), which becomes a dirt road. The road becomes paved and single-family homes, in the \$100 000 to \$150 000 price range, start along the sides of the road. And pretty soon, the mountain starts to look like it does in figure 7.

The mountain peaks are viewed in different fashions by different people. Some view them as a place to extract oil, others as a place to borrow gravel for freeway construction, or as a place to dump trash. Still others view the mountains as a natural playground. Figure 8 shows the Pacific Palisades, where people compete to see who can get closest to the ocean. Some people get a little too close (fig. 9). Some homes built on the edge of a cliff like this have fallen down.

In southern California, construction goes on year round. Therefore, it is almost impossible to monitor growth over a 1-year period through building permits and other available types of data items. This type of development cannot even be monitored closely by aircraft imagery because it is only available on the average of once a year. However, with the new application of satellite imagery that NASA will develop in the future, based on the type of data system set up

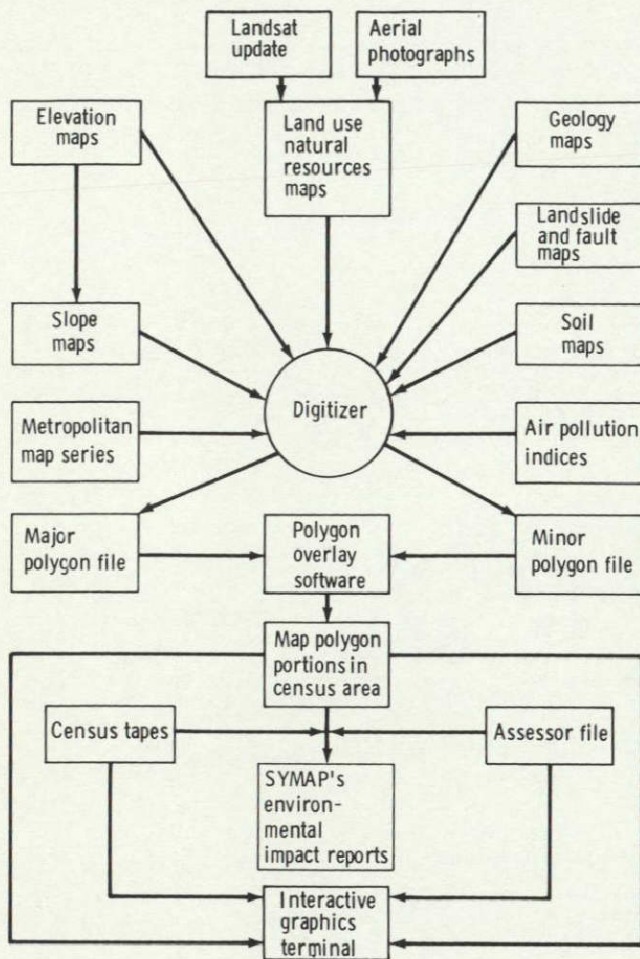

Figure 3.— Land use management information system flow chart.



Figure 4.— The Santa Monica Mountains, illustrating the problem of steep slopes.

with LUMIS, monitoring will be accessible in a faster time frame.

In the LUMIS system, we would like to apply satellite imagery; we have not up to the present time. We have spent our time concentrating on building a data base from high-resolution aircraft imagery and other types of socioeconomic data that are traditionally collected by the city. I would like to point out that when I talk about land use, I'm not talking about land cover. Land use is a study of people and how they use the land, why they live the way they do, where they move, and how they move about in the city. There are some fallacies regarding satellite remote sensing in the urban land use area. The fallacy is that we must continue to drive resolutions higher and higher in order to address the problems in the city. Planners traditionally collect data at the parcel level. Planners that are trying to adopt a general community plan need maps that do just the opposite; that is, to blur the land use boundaries, for example, between single family and open space. We have seen people gather information at the parcel level and then aggregate that to the block level up to the tract level in order to generate a community plan. They deliberately blur the land use distinctions. They wind up

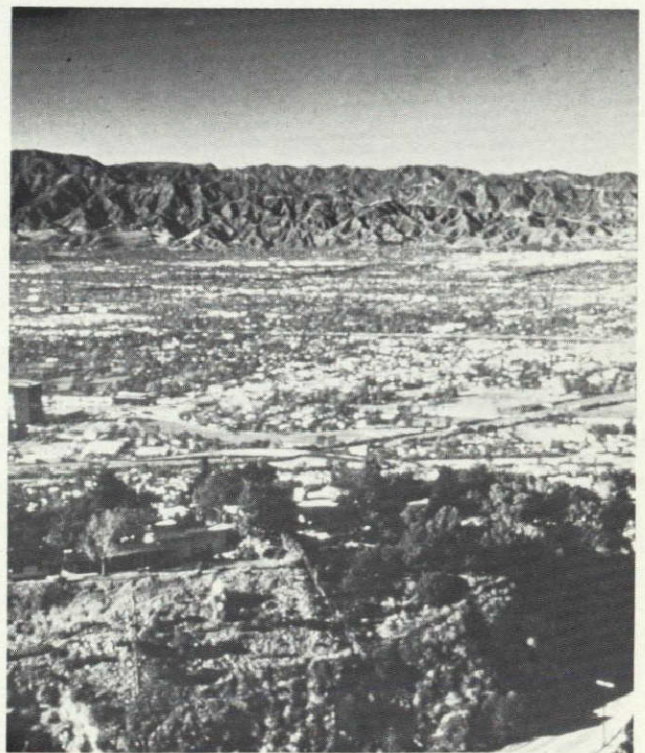

Figure 5.— San Fernando Valley seen from the Santa Monicas.

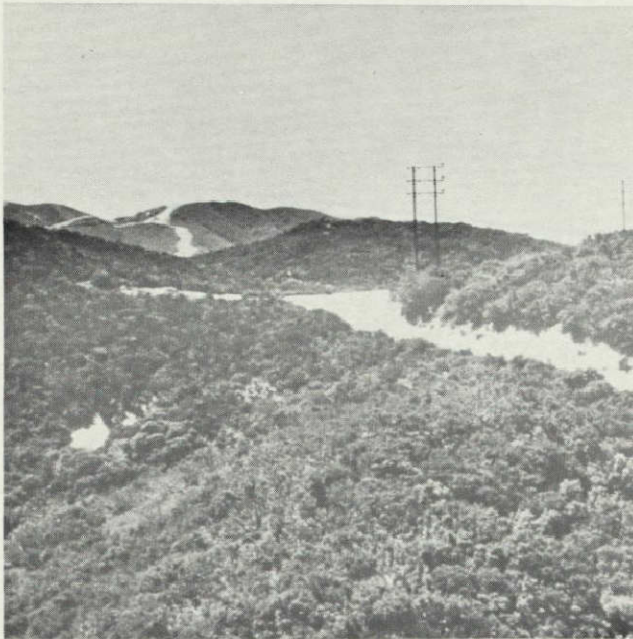

Figure 6.— This is where development starts in a mountain area.

with a land use map that looks exactly like one that could be produced from Landsat imagery. So our challenge is to illustrate that satellite imagery does have a place in these urban community maps.

People in the land use information system business continue to think it is important to gather data inside a block or cell when we do not realize that many planners already know what is there. For example, if there is a hogpen in your block, you generally know about it and it's generally too late to do much about it. But, if there is one coming in 10 miles away, there is a domino effect, in any community, which will probably some day degrade the value of your property. This type of thing is hard to monitor with data that exist in a computer data bank but is easily discernible on a type of land use map or satellite image. So the satellite contributions to solutions of urban land use problems are very significant.

The fact is that we are all going to be living in urban areas, whether we like it or not, by the end of this century. And how your neighbor uses his land affects you. We must learn to monitor what the economists call



Figure 7.— And this is what happens to that fire trail seen in figure 6.

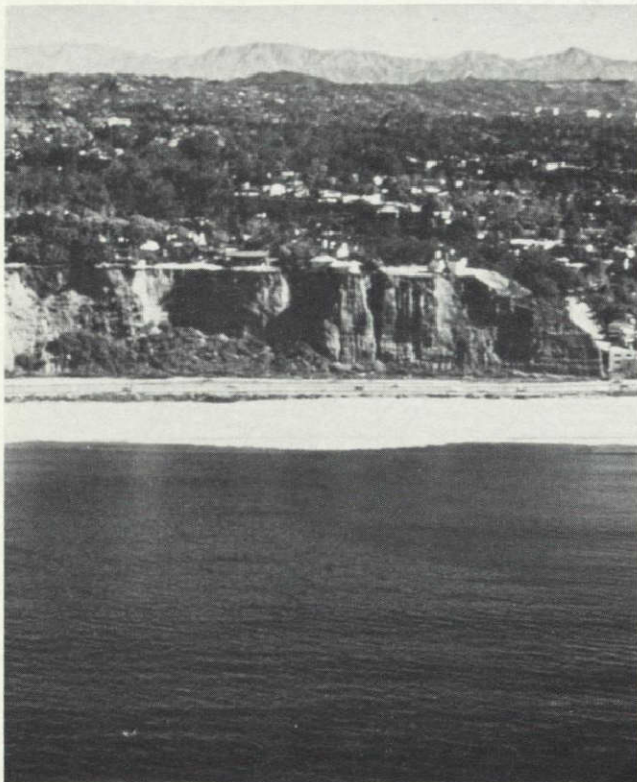

Figure 8.— The Pacific Palisades.

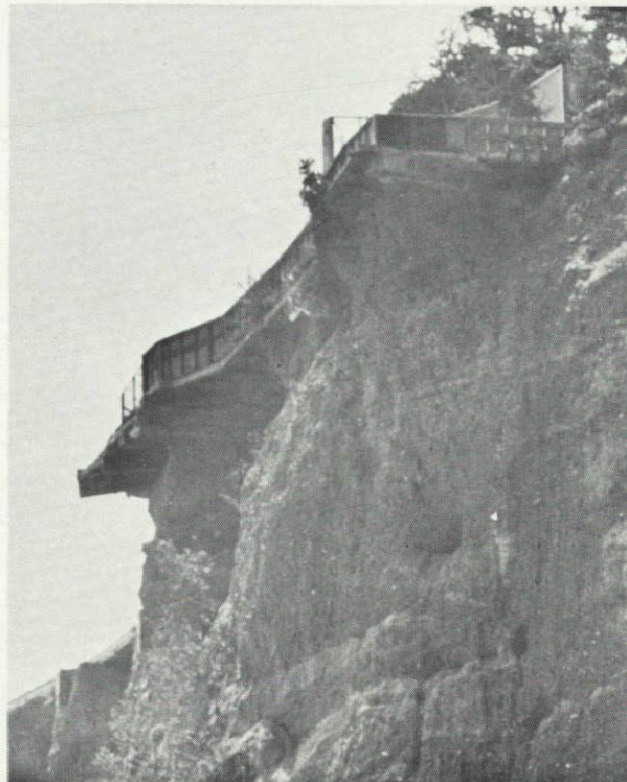

Figure 9.— Competition for a view of the ocean.

spillover effects or externalities — variables in land use that are outside your immediate range of visibility, but are critically important to what happens in your parcel of land. Remote sensing of land use must become a dynamic part of an urban system.

Unfortunately, we cannot predict how something will occur in the future, but once something does happen, we can look back and very easily establish the cause and effect of why it did happen. I have shown you some examples in the Los Angeles area. We think satellite imagery is going to play a key role, and we hope it does when the information gets into LUMIS, in the general plan which consists of community maps. In these instances, land use distinctions are a very politically charged issue.

I think the terracing that occurs in the Hollywood Hills is a very good illustration of something I think could only be monitored closely by satellite imagery. People have been assuming that building permits reflect this terracing. However, after it is terraced, the land may sit like that for 4 years before anybody starts to build on

it. Meanwhile, during dry weather, the decomposed granite on these hills is easily swept up into the air by a gust of wind. Environmental impact simulation, which we are just beginning to understand, is one way to address the domino effect, the spillover effect in urban dynamics. There is a 5-year cycle between the time a community plan is implemented and the time when somebody goes to see whether the plan is being satisfied. This is not acceptable.

Zoning rollbacks are a very interesting application of remote sensing. For instance, Los Angeles is going to define stable neighborhoods, based on a ratio of multifamily homes and single-family residences in an area. For those communities that have a percentage ratio of less than 15 to 20 percent, the city will declare them stable neighborhoods and no more multifamily units of any kind will be allowed there. Monitoring these area ratios for the 450 square miles of the city of Los Angeles at a frequency sufficient to respond to monthly planning commission hearings is a problem tailored to satellite remote-sensing systems.

WATER RESOURCES

Summary

D. B. Simons^a

INTRODUCTION

The papers presented in the Water Resources Session involved most regions of the United States and three other countries: India, Argentina, and Colombia. This summary includes both the materials and illustrations selected from these 24 papers. The material presented by the various authors covers a wide variety of problems important to water resources and water resources development. For the details and the real value of these authors' presentations, readers are strongly encouraged to refer to the original papers. Only by this means can one develop a full appreciation for the great effort that has gone into the application of remote-sensing products to the development and understanding of water resources problems.

This summary is subdivided into broad headings. These are arranged in an order that will hopefully assist the reader in obtaining a better, more meaningful overview of the contributions that have been made, the areas of research that should be pursued, and probable long-term benefits that can be realized by undertaking continued activities of the type briefly mentioned herein.

GEOLOGY AND HYDROGEOLOGY

Skylab and Landsat data are excellent for the identification of major watershed features such as are shown in figure 1. This photograph shows a large-scale rock formation in the Wind River Mountains of Wyoming. Features such as this, as well as drainage networks, major faults, vegetated areas, and so forth, can be considered quite adequately by utilizing remotely

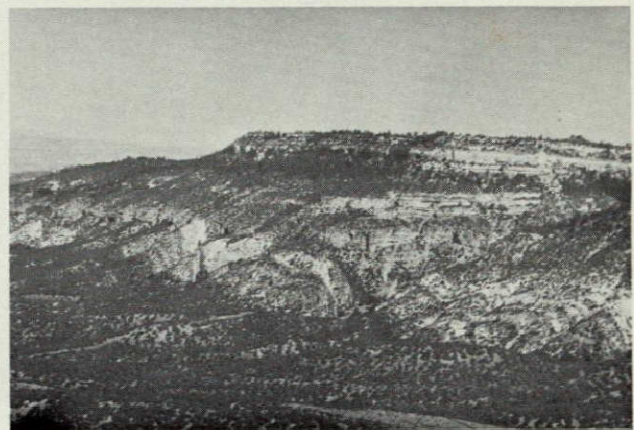

Figure 1.— This type of geological feature — a large-scale rock formation in Wyoming — is easy to identify on satellite imagery.

sensed data. Figure 2 shows a satellite view of the Bighorn Mountains in the State of Wyoming. When one sees the vast area observable by this means, it is immediately obvious that remote sensing from space platforms cannot give the detailed information that may be of interest within a watershed. We can see that aircraft-flown sensors are needed for classification of details where much greater resolution is required. By this means, data can be gathered at such a scale that the details of interest will be adequate for the greater resolution required for the study of particular small areas or points of interest that may be subject to study.

The foregoing two figures were taken from a report (W-1, vol. I-D) on a study oriented toward ground-water recharge and subterranean flows in Wyoming.

^aColorado State University, Fort Collins, Colorado.

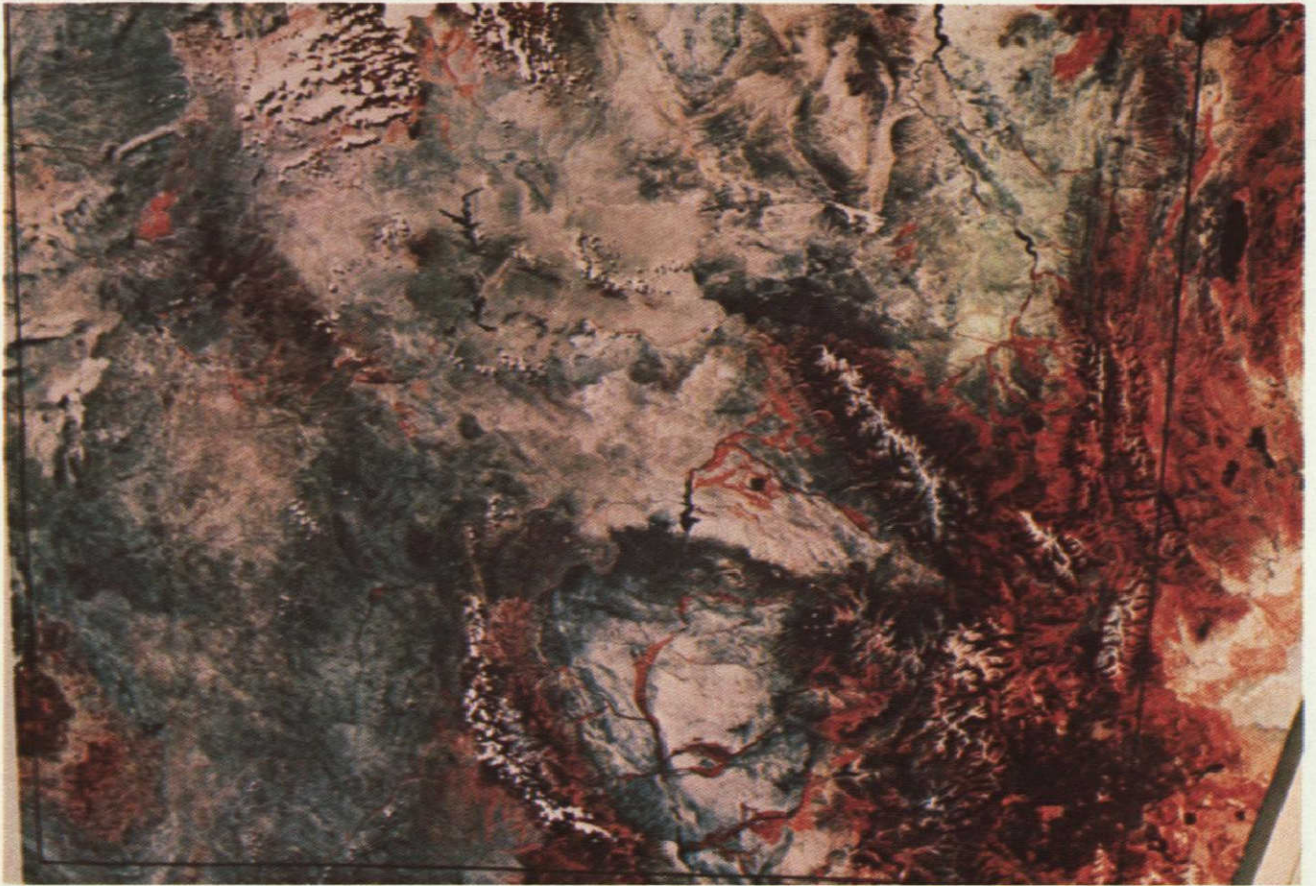

Figure 2.— Bighorn Mountains shown on satellite infrared imagery are an example of how broad an area is visible in one scene.

ANALYSIS OF WATERSHEDS

Our water resources are one of the most valuable assets of our nation. Similarly, water resources are valuable internationally. In order to understand, appreciate, and utilize our water resources, it is necessary to understand the complexities of our watersheds and river systems as a whole. In order to do an adequate job with our water resources, it is absolutely essential that we consider them from a systems basis. When dealing with rivers of any size, it should be borne in mind that rivers are the most rapidly changing of all geomorphic forms.

Figure 3 shows the schematic of a stream network for a particular watershed. The point is that we can clearly identify and study the stream networks and their characteristics using data from Skylab, Landsat, and aircraft sensors. All of the sources of data are extremely useful and the ultimate value of the remotely sensed data depends upon the particular problem being studied. For an overview of the watershed and for the

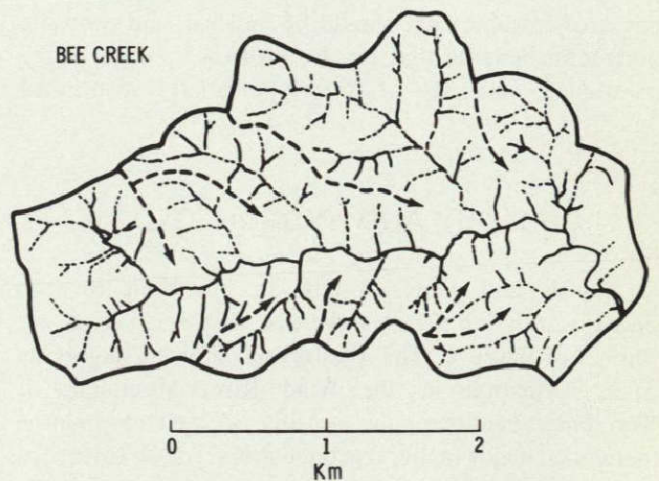

Figure 3.— Schematic of a watershed derived from remotely sensed imagery.

determination of some of its major features, Skylab or Landsat data are indispensable. On the other hand, for studying in detail a short reach of river, riverbanks, or a remote watershed, the aircraft data become extremely valuable because we can concentrate on a small area and obtain sufficiently detailed data to analyze even the most minute aspects of the watershed.

As a result of recent studies of watersheds and their characteristics, techniques have been developed that enable the user to more accurately identify impervious parts of the watershed, whether they are impervious as a consequence of natural formations or as a consequence of man's development of the surfaces. This ability to sense the imperviousness of the surface is another breakthrough which will better enable us to consider the effects of such surface areas on the magnitude of runoff, time of concentration, time of peaking, and so forth.

SNOW AND ICE

As we consider our water resources, we realize that snow cover is an integral and important part of the hydrologic scene. Either directly or indirectly, snow cover affects most of the world's population. This effect is through the snowmelt contribution to floods and droughts, and availability of water for irrigation, for industrial production, for hydropower development, for recreation, and for a multitude of other uses.

Figure 4 is a view of the Wasatch Mountains of central Utah. Using this sort of imagery, we can map the extent of snowpack and its spatial variation with time.



Figure 4.— Extent of snow cover is clearly visible in this satellite view of the Wasatch Mountains in Utah.

Furthermore, it has been verified, using Skylab S192 data, that there is a dramatic decrease in reflectance of snow cover in the near-infrared (1.55 to 1.75 micrometers) portion of the spectrum. Because of this finding, it is possible to differentiate between snow and clouds with an S192-type scanner. Previously, clouds over snow were difficult to identify. The ability to differentiate between snow and clouds is a significant breakthrough for both the hydrologists and the climatologists (W-24, vol. I-D).

Multispectral comparison of satellite imagery has made possible delineation of that part of the snowpack actively undergoing snowmelt. This is another contribution because continued surveillance can identify the active and inactive parts of the pack as they relate to runoff of the watershed at any particular period in time.

PREDICTION OF RUNOFF FROM SNOWMELT

Associated with the snow cover is the prediction of runoff as a consequence of snowmelt. Measurements of the satellite-derived snow cover area have been related to seasonal streamflow (W-26, vol. I-D). Results of this study show that snow cover is a potentially important index parameter for reducing error in runoff forecasts.

Because of the promising results regarding improved forecasts, NASA has activated a program involving six Federal agencies and three state agencies. These groups are doing snow mapping and are conducting tests related to using snow area technology and operational systems to better improve estimates of runoff. Even a small increase in the precision of predicting runoff can be an extremely important contribution because water and knowledge of its availability is so fundamental to our technology and economy.

HYDROLOGIC LAND USE CLASSIFICATIONS

Hydrologic land use classifications are important to river watershed management, for example, in the Patuxent River watershed in Maryland (fig. 5). The Patuxent River is Maryland's largest intrastate river. This watershed was analyzed using satellite and aircraft data. Multispectral analysis of the data yielded vital information regarding the water surface in the watershed, the agricultural activity and type of agriculture in the watershed, urban development therein, residential construction, forested areas, marsh areas, and

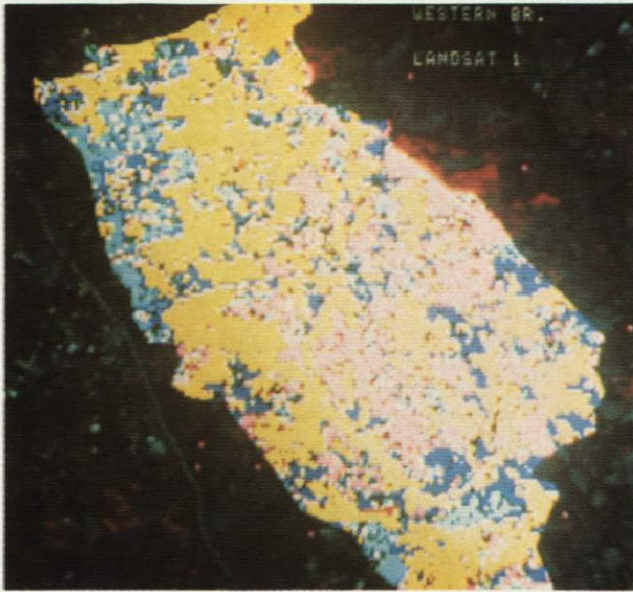

Figure 5.— Computer-implemented land use classifications of the Patuxent River watershed in Maryland.

so forth. Such analysis techniques have been applied to satellite and aircraft data to provide both a broad and detailed information base related to conditions on the flood-prone areas in the watershed. These data have been compared to conventional U.S. Geological Survey flood-plain boundary maps. The study (W-13, vol. I-D) clearly verified that unflooded regions existed within the USGS-identified flood boundaries. An important point

should be made here. When we use remotely sensed data to study a watershed, we have an opportunity to look at the total watershed. Of course, the detail depends upon the type of remotely sensed data available. On the other hand, when boundaries are based upon field reconnaissance and field surveys, it is not always possible to take the time or put in the necessary effort to fully appreciate all conditions adjacent to the streams. Consequently, there can be, as in this instance, unflooded areas within flood-plain areas as identified by conventional methods.

The cost of conducting studies of watersheds varies greatly depending upon the details desired. In this instance, it was pointed out that watershed mapping of the type alluded to could be conducted for an approximate cost of \$4.30 per square kilometer when using data from satellites. Using this technique enables the mapper to obtain an excellent understanding of at least 90 percent of the watershed being studied.

Further data on cost-effectiveness were provided in several of the other papers discussed in the water resources session (including W-22, vol. I-D). Table I shows land inventory costs in Kern County (Santa Barbara), California. Again, a survey of the information provided in this table shows that significant financial savings result from utilizing remotely sensed data properly. However, it turned out that the most economical method of conducting the land survey involved utilizing U-2 aircraft imagery. It should be

TABLE I.— ACCURACIES AND COST-EFFECTIVENESS OF INVENTORIES BY REMOTE SENSING

Inventory procedure	Percentage accuracies, relative (absolute)		Cost, dollars per 10 000 acres	Time required to inventory 456 000 acres
	Cropland	Noncropland		
Water district field investigation	Assumed 100		66.00	6 weeks
1:125 000 high-altitude photography	98.5 97.2	98.9 96.4	.87	8 hours
1:1 000 000 Landsat imagery	99.1 98.0	98.4 98.0	1.81	16.5 hours

noted that both the satellite data and U-2 data provided information more cheaply and more effectively than it could be obtained by conventional methods. Another important point is that using this type of surveillance enables one to look at the total area involved at whatever degree of precision one wishes, depending upon the economics of the situation. Such information helps resolve differences in survey statistics regarding the areas of irrigated land, fallow land, and other types of land utilization. (See the following paper.) More precise information regarding such quantities assists greatly in planning and developing an area. It is also extremely useful to Federal and state agencies that are interested in inventories.

SOIL MOISTURE

Skylab microwave data (fig. 6) have indicated a high correlation between radiometer temperature and soil moisture content near the land surface. Data from the L-band radiometer seem to correlate best with soil moisture (W-6, vol. I-D). Figure 7 shows soil moisture variation for an area using color coding to indicate different soil moisture values. Such information is extremely valuable to all groups and individuals interested in watershed utilization and development. For example, in considering runoff from watersheds, knowledge of the moisture values at any point in time over the total watershed would add greatly to the precision with which runoff and sediment discharge from the watershed could be estimated for immediate and subsequent storms.

EVAPOTRANSPIRATION

Also in considering water availability and utilization from and on the watershed, a knowledge of the evapotranspiration rates is important. More specifically, it is vital to irrigated agriculture and water supply for all users. Maps estimating evapotranspiration rates from the agricultural landscape have been produced using S192 Skylab data (W-21, vol. I-D). These results were evaluated using ground measurements. Such studies will greatly benefit operational irrigation scheduling management systems. In all aspects of utilizing remotely sensed data, field verification work is an important and fundamental part. Without such ground-truth information, the accuracy of the analysis of satellite and aircraft sensed data would be greatly reduced.

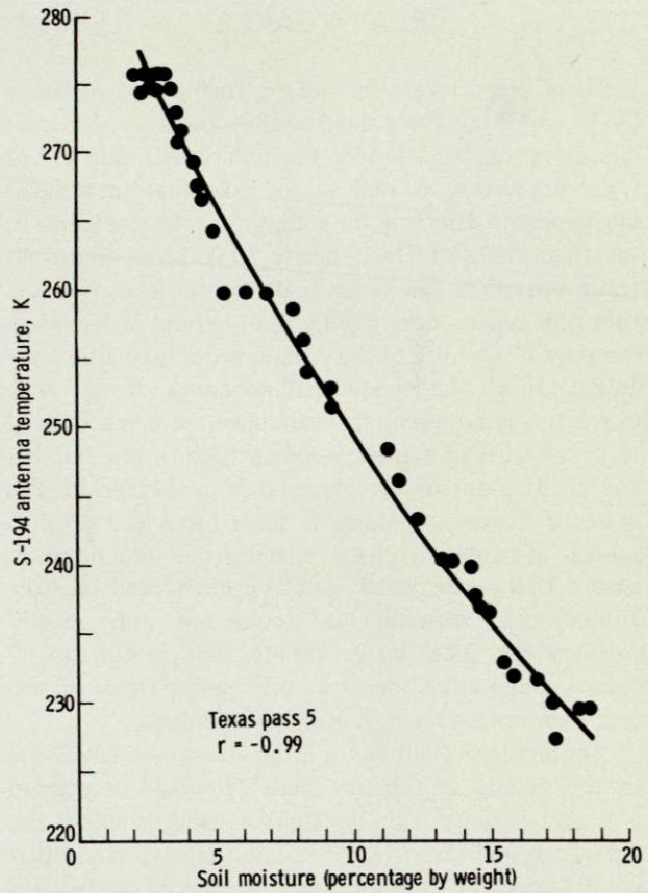

Figure 6.— Microwave data correlated with soil moisture.

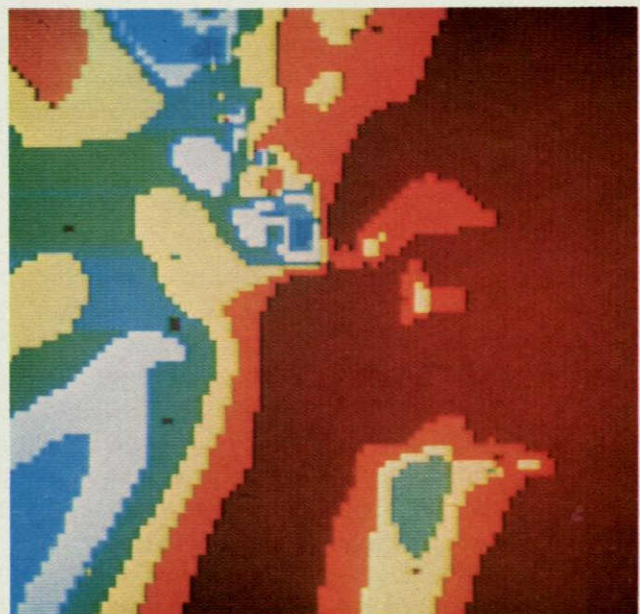

Figure 7.— Color coding indicates variation in soil moisture.

PLAYA LAKES

Many playa lakes exist in the High Plains of Texas (W-18, vol. I-D). These small, shallow lakes are of greater importance as we consider the fuller utilization of our water resources, as well as any role that these lakes might play in affecting the salinity of adjacent lands. In the High Plains of Texas, nearly 70 000 irrigation wells are in operation. The result is that water is being mined from this region more rapidly than natural recharge can resupply it. Overuse of the ground water may ultimately greatly affect the agricultural economy of the area. Currently, remote-sensing techniques are being utilized to obtain current statistical information on the number and areal extent of the playa lakes in this region. The State of Texas is looking at these lakes as a possible source of water to help recharge the ground-water basins. If the lake water could be introduced into the ground-water reservoir, it would not only greatly enhance the local water supply, but would greatly reduce evaporation losses in the region. Lakes of this type experience very high evaporation losses.

Another important factor is the effect such lakes have on the salinity of adjacent lands. It should be pointed out that salinity can be studied using satellite and aircraft sensed data, but it is important to stress that salinity conditions are dynamic. Because of its transient nature, salinity certainly shows up quite differently at different times. After a period of wetness, much of the saline areas may be difficult to observe as a consequence of the flushing action of the rainfall. Conversely, as dry periods continue, the saline areas grow in size and are easily identified. Therefore, careful analysis must be made to make certain that reliable results are obtained.

SURFACE RUNOFF

Many methods are currently used to estimate surface runoff from watersheds. Figure 8 shows a runoff relationship based upon input rainfall and a so-called curve number. The curve number is estimated using remotely sensed data, and this number is related to the watershed soil cover complex (W-15, vol. I-D). Such a relation is simple and effective. It was stressed by researchers that considerable advantages are to be gained by continuing to utilize simple effective concepts.

On the other hand, as a consequence of improved data provided by satellites and aircraft, more complex methods of estimating surface runoff are gaining attention. With the ability, through remotely sensed data, to obtain information on land use, antecedent

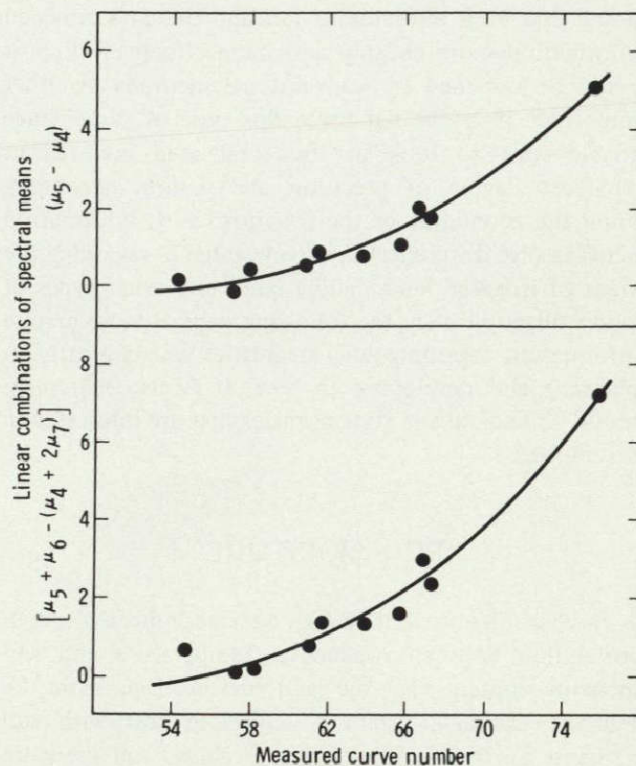

Figure 8.— The relationship of multispectral scanner data to measured watershed runoff curve numbers.

moisture, precipitation, evapotranspiration, geology, geometry of the watershed, vegetative types, and so forth, it is obvious that it will be beneficial to utilize such data to provide advanced techniques for assessing our water resources and routing them from the watershed areas.

FLOOD HAZARDS

The need for knowledge of flood hazards was stressed by many of those reporting. Flooding is an international problem. From the beginning of time, man has tended to populate the river valleys and banklines of the rivers. Two of the principal reasons for this are that the river valleys are fertile and the rivers provide, in many instances, cheap transportation. Consequently, we need information on the extent of inundated areas, frequency of flooding, and possible remedial measures that could help alleviate flooding. Also, it is fully realized that another important aspect is that the overall environmental issues must be considered.

During periods of flooding, large areas adjacent to river and stream channels can be subjected to various degrees of inundation. As a consequence of this, certain

basic information on the extent and potential frequency of flooding is vital for more efficient land utilization.

In Colombia, South America (W-9, vol. I-D), images from Landsat and side-looking airborne radar (SLAR) have been used to help understand and solve problems associated with flooding. Suitable evaluation of the potential for flooding relates to utilization of much of the information alluded to in the foregoing paragraphs: geometry and geology of the watersheds, vegetative cover, types of soil, how the soil is utilized, antecedent moisture, snow cover, and so forth. Also, we see how all of these many factors tend to tie together and complement each other to obtain common, useful answers.

WATER QUALITY SURVEYS

Remote sensing is of great value in assessing the water quality of both rivers and lakes. In a water quality study (W-12, vol. I-D) of the Choptank River in Maryland using Landsat-1 data, analysis of the data produced eight distinct classes of water. Also, those who conducted the study found that it was possible to classify water both in lakes and in rivers to some extent by depth. With the advent of new water-penetrating film, it is anticipated that more and more work will be done in the future dealing with this particular topic and very useful results should be forthcoming. Studies of this type show that the identification of water quality problems related to the biomass and the sediment in a system is feasible. The results presented in the papers dealing with this subject certainly indicate the production of vital and valuable results, and we anticipate additional activities in this subject area in the future.

Another aspect of water quality involves the inflow of contaminated streams to main-stem streams. Hence, there is an urgent need for information concerning the mixing of flows from sewage treatment plants, industrial plants, and so forth with the water in a particular river.

Figure 9 shows a typical instance where sewage effluent is entering a stream in Wisconsin. In one study (W-11, vol. I-D) in which lateral and longitudinal mixing was considered, the process was studied utilizing thermal scanning and a two-dimensional mathematical model to obtain the results shown in figure 10. This figure clearly illustrates that it is possible to differentiate, using remotely sensed data, between a polluted effluent entering a stream and the better quality water in the stream. Such studies also give vital information concerning the rates and extents of mixing with respect to time and space. In order to conduct this study, it was

necessary to average data; otherwise, considerable variation existed along the line dividing the two flows.

Additional work is required in this area. It is essential that we know how pollutants entering a stream, either from point or nonpoint sources, mix with the system. A great distance is sometimes required before thorough mixing is achieved. In the Missouri River, a thermal plume from a steam powerplant was tracked some 15 statute miles downstream of its source. Pumped water from the Welton Mohawk Irrigation District being dumped into the Colorado River could be followed and clearly identified for as much as 8 to 10 statute miles downstream of the confluence. The water from the Welton Mohawk Irrigation District was contaminated saline water and was much colder than the water in the Colorado River. Hence it was easy to differentiate between these two flows. Again, it should be stressed that such studies will continue to provide valuable information pertinent to the environment and better utilization of our total resources.

RIVER MECHANICS

In the preceding paragraphs, we discussed in some detail the broader view as it pertains to watersheds, water resources development, and some of the factors that can be sensed on the watersheds. It is possible to make detailed studies of the river scene by use of data from aircraft sensors. Figure 11 is a photograph of two flows joining downstream of an island in the Mississippi River. These flows come together at different velocities and create a shear flow that generates a line of large vortexes. These vortexes not only exist at the water surface, but extend to the bed of the stream. In figure 12, the increased depth below this line of vortexes has been mapped. Such techniques can be used to observe and study the phenomena illustrated (W-10, vol. I-D). These techniques provide extremely valuable information concerning the location of the navigation channel, the distribution of sediments in the cross section of the river, the distribution of velocities laterally and longitudinally through the system, and so forth.

We can conclude in the broad perspective that, by using remotely sensed information from satellites and aircraft, we can determine geologic controls along the rivers and identify major structures that may be of interest. Also, one can identify the different types of soil making up the riverbanks and the land adjacent to the rivers; the types of vegetation can be observed and related to soil type; the rivers can be classified according

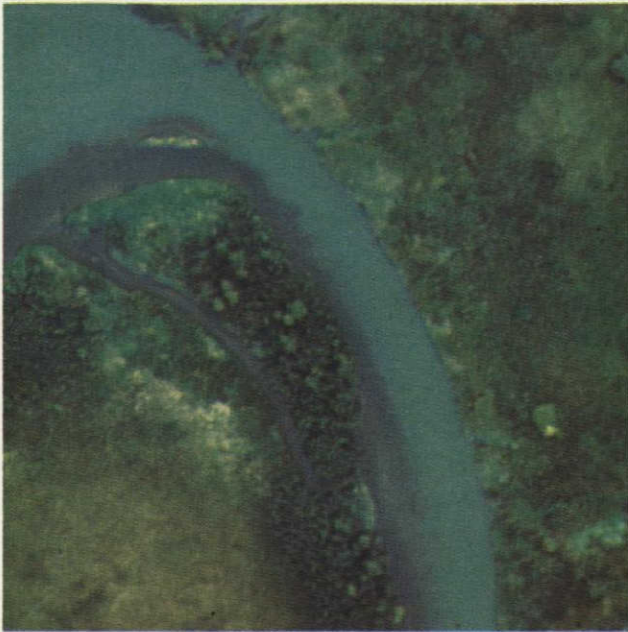

Figure 9.— Sewage entering a stream is clearly visible. The light gray-green is the normal flow of the stream. The dark gray along the left bank is the effluent.

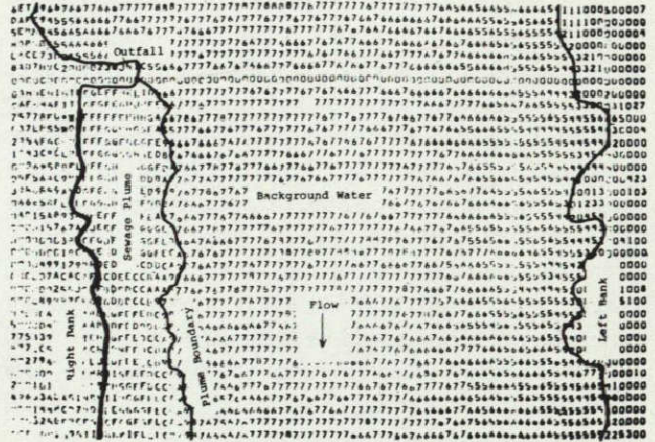

Figure 10.— Mathematical model of sewage plume.

to form; and, of course, because rivers are dynamic, a sequence of photographs taken over a period of time provides extremely valuable information on the rate of change with respect to time. Such information is important in the development of our water resources systems.



Figure 11.— Two water flows joining in the Mississippi River.

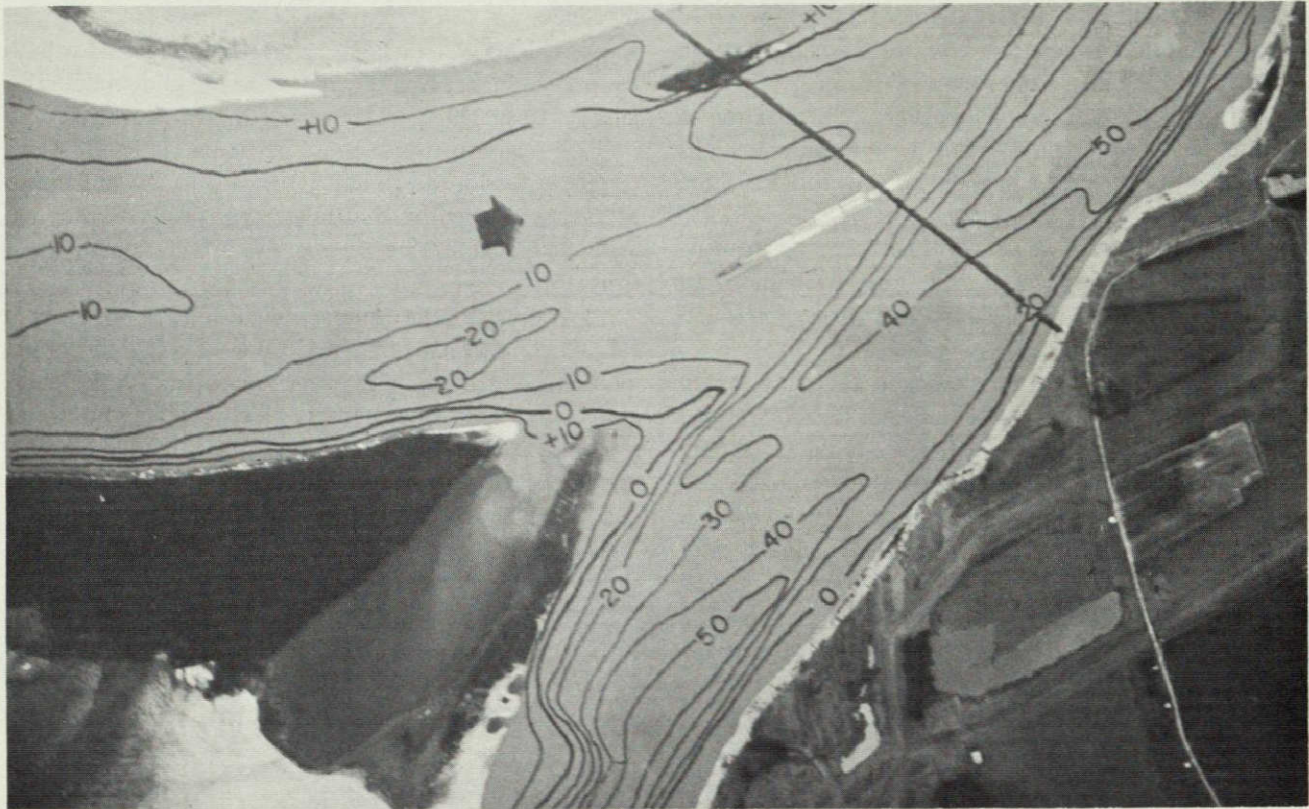

Figure 12.— Same photograph as figure 11 with water depths mapped.

SUMMARY

In summary, the water resources session concluded that remote-sensing techniques are extremely useful for all aspects of the analysis of watersheds, for example, for determining runoff from watersheds, determining flood hazards, and for conducting flood-zone studies. In addition, such studies are extremely valuable in connection with identification and analysis of droughts. As was pointed out, soil moisture can be mapped, and this information can be extremely valuable as it relates to runoff from the system. Ground water can be considered, and methods of improving ground-water storage as well as of identifying ground-water reservoirs is a possible use of remotely sensed information. Also the salinity problem, the water-logging problem, is one easily identified and one that can be studied very beneficially using remote-sensing techniques. However, in the case of salinity, it should be borne in mind that the scene is quite dynamic and considerable averaging must be done to get good results. Finally, the results of such studies can be incorporated into models that lead to planning, decisionmaking, and ultimate development.

Following the water resources session, a workshop was held and several points that are considered important were identified.

1. In the future, it is apparent that people utilizing remotely sensed data will be more and more interested in obtaining information on more nearly a real-time basis.

2. Work should continue on the watershed parameters.

3. Researchers should take a careful look at the significance of future studies on snow and ice.

4. With the further development of remote-sensing techniques, more sophisticated and accurate models of runoff, sediment yield, water quality, salinity, and so forth will be developed. Many such studies have been completed at least through the preliminary phases.

5. There must be more cooperation between those working in remote sensing and in modeling. The work group stressed that there should be a marriage between the remote sensors and the modelers to get the most from both fields.

6. It is necessary to develop better working relationships between the research communities and the users.

7. It is essential to stress the importance of practical communication, cooperation, education, and utilization of results forthcoming from such studies.

8. In the future, there will be a greater utilization of satellite, high-altitude, and low-altitude sensing missions simultaneously to give adequate information for more detailed studies.

9. The availability of data will be an important issue in the future. It is necessary that better methods of making data more readily available at an economical and timely rate be developed.

10. Because many of those utilizing remotely sensed data do not have access to advanced and refined machine-processing equipment, such equipment should be made available to the small users at a reasonable fee.

11. As we proceed into the future, there will be much more interdisciplinary effort. There will be a greater

tendency for those working in geology, land use, the watersheds, water quality, agriculture, and so forth to cooperate in arriving at more meaningful and better answers to specific problems.

12. Finally, many of those participating in the water resources session are looking forward to the possibility of advanced satellites that relate specifically to problem areas such as hydrology, snow, rivers, water quality, and so forth.

In any event, the general conclusions resulting from this session attest to the great value of remotely sensed data in connection with water resources studies. It is anticipated that the papers presented in the water resources session will not only add to the current storehouse of knowledge, but will also help establish a path of endeavor that will lead to even better results in the future.

Remote-Sensing Applications to Water Resources Management in California*

Barry Brown^a

INTRODUCTION

The California Department of Water Resources has long recognized the value of remote sensing for water resource development and management. For nearly three decades, it has been using low-altitude aircraft imagery of various types for inventorying and monitoring land features and water supply and use conditions over large areas of the state. Data obtained have been used in evaluating regional water use trends and in periodically reassessing the need for, location, size, and uses of proposed water facilities.

Although most of the conventional remote-sensing applications that we have found are not new, what makes the department's experience unique is the diversity of applications within a single agency. This diversity has come about, first, because of the magnitude of planning for statewide distribution of water that resulted from the state's size and maldistribution of waters. Secondly, many remote-sensing applications have resulted from special problems created by climate, by topography, and by the fact that water resources management involves consideration of water resources underground, on the surface, and in the atmosphere. A third factor that has involved the department in a greater variety of remote-sensing activities than most other agencies is the fact that this nearly 30-year period of our involvement has encompassed the planning, constructing, and operating phases of the California Water Plan.

In more recent times, a major factor that has influenced our remote-sensing activities has been the need to protect and enhance our environment. Water and related land use planning is considered by many as the key to this type of function. Planning for water

management is acknowledged as particularly important because of (1) the direct impact that water development projects have upon the environment and (2) the indirect impact that such projects have upon the social and economic well-being of our society. The department recognizes its responsibility to minimize adverse environmental impacts and is seeking new ways of evaluating environmental factors.

While conventional remote-sensing and other data gathering techniques have proved adequate for most purposes, we have recognized for many years a number of shortcomings, such as the inability of the techniques to rapidly inventory or monitor land use and land cover conditions over large areas. Because we believe that high-altitude and satellite imagery in many cases will permit this rapid inventorying, we have undertaken a number of projects to explore their potential.

SCOPE

The remote-sensing applications studies undertaken by the department are summarized in table I. The table distinguishes between those applications that have been subjected to a qualitative evaluation and those that have received a quantitative assessment. In the eight cases involving the use of high-altitude imagery exclusively, the quantitative evaluation has consisted of a cost-effectiveness comparison with conventional imagery and a discussion of quality factors. Seven of the eight studies and details of the satellite studies are reported in this paper.

The satellite studies have just been initiated and no significant results are yet available. The discussion in the text briefly describes test objectives and plans to implement them.

*Based on paper W-19 (vol. I-D).

^aCalifornia Department of Water Resources, Sacramento, California.

TABLE I.— CALIFORNIA DEPARTMENT OF WATER RESOURCES REMOTE-SENSING APPLICATIONS STUDIES

Application	Imagery evaluated				Nature of evaluation	
	U-2	Landsat-1	Landsat-2	NOAA-2 ^a	Qualitative	Quantitative (b)
Water resources planning and operations applications:						
Geologic studies						
Regional geologic assessment	X				X	
Detecting possible water-bearing areas	X				X	X
Urban boundary delineation	X				X	X
Land use updating (two studies)	X				X	X
River studies						
Watershed characterization	X				X	X
Waterway mapping	X				X	X
Sand and gravel bar mapping	X				X	
Wildlife habitat inventorying	X				X	
Map substitute	X				X	
Snow cover assessment ^c	X	X		X		X
Irrigated lands mapping (two studies) ^d	X		X			X
Algal detection and mapping	X				X	
Water quality monitoring ^c	X		X			X
Displays	X	X			X	
Disaster assessment applications:						
Litigation	X				X	
Flood damage assessment	X				X	X

^aA weather satellite used by the National Oceanic and Atmospheric Administration.

^bFor cost-effectiveness studies only.

^cContract with NASA through Goddard Space Flight Center.

^dOne of the studies is a cooperative agreement with Space Sciences Laboratory, University of California, Berkeley.

APPLICATIONS STUDIES

In spite of the general recognition by department investigators that high-altitude and satellite imagery are potentially valuable planning aids, the process of getting these people involved in evaluation studies has been slow. This hesitancy has been partly attributable to a basic reluctance to take on something new when the old techniques have worked well enough. However, a bigger factor probably has been the lack of special funding for application studies, thereby making it necessary to carry out the studies in conjunction with budgeted work. Program managers believed that investigative and reporting requirements would be more demanding than their programs could support.

To overcome these problems, study personnel were asked to report only on the advantages the imagery appeared to offer over conventional data gathering techniques. This approach placed few demands on the study participants and stimulated interest in the program.

The subjective evaluation comments by study personnel were useful in that they clearly revealed many potential applications and provided ample justification

for a second level of analysis — one aimed at comparing costs of data acquired from high-altitude or satellite imagery to costs of data acquired from conventional data sources.

Some preliminary results of such cost-effectiveness comparisons are discussed in the following sections. A third level of analysis (benefit-cost) may be attempted in the future for flood or flood-related problems for which imagery benefits can be clearly identified.

COST-EFFECTIVENESS COMPARISONS

The cost-effectiveness comparisons were made by a team of department economists who interviewed study participants. The informal subjective comments from the first-level analysis were used as the starting point for these interviews. All data and important comments generated by the interviews were systematically recorded, evaluated, and, where necessary, corrected. The corrected data were then used to develop cost ratios. The ratios for the seven applications reported are summarized in table II.

TABLE II.— SUMMARY OF COST-EFFECTIVENESS COMPARISONS

Application	Data costs		Cost ratios
	From high-altitude imagery	From conventional data sources	
Detecting possible water-bearing areas	\$ 73	\$ 903	1:12.3
Urban boundary delineation	4 807	9 457	1:2.0
Land use updating	2 459	2 785	1:1.1
Land use updating (coastal area)	24 812	25 000	1:1.0
Watershed characterization	5 169	6 068	1:1.2
Irrigated lands mapping	9 101	12 380	1:1.4
Waterway mapping	374	1 176	1:3.1
Flood damage assessment	575	6 913	1:12.0

Table III gives the costs associated with the use of high-altitude imagery compared to the costs associated with conventional data sources. Nonquantifiable aspects of the applications are summarized in the text.

In making cost comparisons, all costs were considered except flight costs of the high-altitude aircraft. It was assumed that these costs would continue to be borne by Federal agencies and that imagery obtained would continue to be available at current rates. No costs were incurred in training study personnel; the various disciplines involved were adequately trained in the basics of imagery interpretation.

HIGH-ALTITUDE IMAGERY APPLICATIONS

Detecting Possible Water-Bearing Areas

Introduction.- This application compared the costs of using U-2 aircraft imagery to available conventional imagery in locating geologic indicators of possible water-bearing areas (primarily lineaments) in a water deficit area of approximately 400 square statute miles surrounding the Sierra Nevada foothill community of Plymouth. The city requested the search to help decide whether a study should be made of the feasibility of developing local ground water to alleviate a water shortage problem.

Both kinds of imagery revealed the presence of unmapped lineaments in the area that could be due to fractures or faults which might be water-bearing areas. Although these results were sufficient to justify a feasibility study, the city decided not to conduct the study for other reasons. The detailed U-2 costs and those associated with conventional imagery are presented in table III.

Procedure.- Used in this study were 9- by 9-inch, 1:130 000-scale color-infrared (CIR) positive transparencies obtained by high-altitude aircraft. The conventional photographs used were standard panchromatic 9- by 9-inch 1:20 000-scale contact photographs. Because no funds were available for field work, the application study was conducted by imagery interpretation alone.

The focus of the study on lineaments as indicators of water-bearing areas severely limited the usefulness of the low-elevation black-and-white contact photographs. The small coverage and great detail made it virtually impossible to detect lineaments on single photographs.

To overcome this problem, the contact prints were mosaicked together into two separate panels with each covering approximately the same area as a U-2 photograph. The mosaics were then photographically reduced to U-2 scale for the study.

Data processing was not included as a cost because it consisted only of marking unmapped lineaments on the photograph and of transferring to the base maps. This process required only a few minutes.

Discussion.- Unmapped lineaments could be detected on both photographic formats but were interpreted with less confidence on the mosaics because of confusion created by photograph match lines. The mosaic also was found to be less useful than the CIR U-2 photographs in revealing vegetative anomalies associated with lineaments. This was partly because of the sharper ground/vegetation contrasts that existed on the CIR film. It also probably was partly a result of the poorer resolution of the mosaic in going through two more reproduction steps than the U-2 imagery and in being on a poorer resolving medium (paper) than the CIR film. The large relative cost savings that were realized in using the U-2 photographs resulted from not having to prepare photomosaics.

Urban Boundary Delineation

Introduction.- The costs of mapping approximately 4800 square statute miles of urban areas (10 acres in size or larger) in the cities of Los Angeles, San Diego, Santa Barbara, and Ventura, and in the Upper Santa Ana drainage basin, using U-2 imagery were compared to the costs of mapping with specially flown conventional imagery. The mapping of urban areas was done as a preliminary step in mapping prime agricultural lands adjacent to urban centers.

Procedure.- The study used U-2, 9- by 9-inch CIR transparencies at a 1:130 000 scale. In the absence of complete or current available imagery, a decision was made to fly the area with 35-millimeter color film.

The U-2 transparencies were vertically projected onto 1:62 500-scale base maps, and urban areas were delineated on them. The 35-millimeter color slides were projected onto a screen, and urban areas were visually translated to the 1:62 500 base maps.

Processing of the data was not a cost factor because the maps showing the urban areas were the end product wanted by the agency requesting the information.

Discussion.- The twofold greater cost associated with using 35-millimeter color transparencies was primarily because it took a week to fly the area and a week to

index the slides. A total of 128 man-hours was required for photographer, navigator, and personnel to index the photographs. Rental costs for airplane and pilot were the equivalent of approximately 172 additional man-hours.

In interpreting the photographs, it was observed that locating the boundary between contiguous urban and small agricultural areas was accomplished more easily on the U-2 CIR photographs than on the color slides. This apparently was due to a greater contrast between the urban and agricultural areas on the CIR than on 35-millimeter color slides. On the other hand, 35-millimeter photographs generally were more useful for delineating urban areas from areas covered by native vegetation.

The comparison of the two film formats also revealed that the U-2 transparencies provided a more uniform scene rendition than did the 35-millimeter slides. The U-2 imagery was flown in less than an hour, whereas the 35-millimeter took a week to fly. As a result, considerable variations in Sun glare, atmospheric conditions, et cetera, were noted on the 35-millimeter slides that were not apparent on the U-2 imagery. A minor disadvantage noted in using the 35-millimeter photographs was the visual translation of urban area boundaries onto the base maps.

Land Use Updating — Coachella/Imperial Valleys

Introduction.- Costs of using U-2 imagery to update broad land use categories for approximately 500 square statute miles of the Imperial and Coachella Valleys were compared to costs of using available commercial panchromatic photographs. The revised land use data were needed for a cooperative local-State-Federal study of the Salton Sea and for a comprehensive water quality plan being prepared for the desert basins. Detailed costs associated with using the U-2 and panchromatic photography are presented in table III.

Procedure.- The high-altitude imagery used was 1:130 000-scale, 9- by 9-inch CIR positive transparencies. The transparencies were projected onto sepia prints (at 1:24 000 scale) containing an earlier land use pattern. Changes in urban irrigated and nonirrigated cropland and recreational boundaries were then interpreted and inked on the maps. The available panchromatic photography was 9- by 9-inch contact prints at a scale of 1:24 000. These photographs were evaluated in the same manner as were the U-2 photographs.

Both sets of maps were then taken to the field and delineations spot checked and missing data filled in. Sepia prints were obtained from these revised maps, and land use acreage values were derived by the cutting and weighing technique and the use of a computer.

Discussion.- Both types of imagery were satisfactory for accomplishing the mapping task. The 13 percent higher cost of using the conventional panchromatic film was caused primarily by the additional time required to handle 80 rather than 12 photographs. This cost was partly offset by the higher cost of the CIR U-2 photographs.

The mapping done from the small-scale U-2 imagery, surprisingly, was as good as or better than that done from the large-scale panchromatic photographs. Although no attempt was made to quantify the accuracy of the interpreted data, the general observation was that irrigated cropland was more easily and more accurately mapped on the CIR imagery. Urban boundaries could be delineated equally well on both types of imagery.

Land Use Updating — Coastal Los Angeles County

Introduction.- This study was designed to compare costs of using U-2 photography to conventional panchromatic photography in updating major land use types within the coastal Los Angeles region, an area of more than 1800 square statute miles. The information was needed to verify the adequacy of a land use survey by the Los Angeles City Planning Commission, to update its data, where necessary, and to split out certain categories to bring them into conformance with the department's classification system. Detailed costs associated with using the U-2 and panchromatic photography are presented in table III.

Procedure.- For this study, 1:32 500-scale, 9- by 18-inch CIR U-2 positive transparencies were compared against 1:24 000-scale commercial panchromatic 9- by 9-inch contact prints. Both sets of photography were projected onto sepia prints, interpreted, and field checked in the same manner as described for the desert study.

Discussion.- Both sets of photographs adequately satisfied study mapping requirements. The parity reflected in the cost comparisons is surprising considering that the 1:32 500-scale U-2 photograph cost was almost five times that of the panchromatic photographs. This cost was offset by the time saved in handling 62 percent fewer photographs. The cost ratio

TABLE III.-- COSTS ASSOCIATED WITH THE USE OF HIGH-ALTITUDE IMAGERY AND CONVENTIONAL DATA SOURCES

High-altitude imagery				Conventional data sources			
Function and type of cost	Quantity	Unit cost ^a	Total ^b	Function and type of cost	Quantity	Unit cost ^a	Total ^b
Detecting possible water-bearing areas							
Acquiring high-altitude imagery and supporting data sources				Acquiring data sources			
Purchase of high-altitude photographs	2	\$18.53	\$ 37	Low-altitude photographs (existing)			
Purchase of maps	6	1.15	7	Purchase	40	\$ 2.33	\$ 93
				Special processing	2	386.75	774
				Purchase of maps	6	1.15	7
Data collection and interpretation:				Data collection and interpretation:			
Interpretation	4.5 hr	6.54	29	Interpretation	4.5 hr	6.54	29
Total			\$ 73	Total			\$ 903
Urban boundary delineation							
Acquiring high-altitude imagery and supporting data sources				Acquiring data sources			
Purchase of high-altitude photographs	70	\$14.05	\$ 984	Low-altitude photographs (specially flown)			
Purchase of maps	104	4.70	489	Flight planning	8 hr	\$18.00	\$ 144
				Contracted services	40 hr	70.00	2 926
				Film purchase and processing	230 ft	1.22	280
				Flight observer	40 hr	17.99	720
				Photographer	40 hr	20.85	834
				Miscellaneous	40 hr	10.60	424
				Purchase of maps	104	4.70	489
Data collection and interpretation:				Data collection and interpretation:			
Interpretation	185 hr	18.03	3 334	Interpretation	200 hr	18.20	3 640
Total			\$ 4 807	Total			\$ 9 457
Land use updating -- Coachella/Imperial Valleys							
Acquiring high-altitude imagery and supporting data sources				Acquiring data sources:			
Purchase of high-altitude photographs	12	\$23.34	\$ 280	Low-altitude photographs (existing)			
Purchase of maps	16	1.01	16	Purchase	80	\$ 3.00	\$ 240
				Special processing	1	6.00	6
				Purchase of maps	16	1.01	16
Data collection and interpretation:				Data collection and interpretation:			
Interpretation	64 hr	18.03	1 154	Interpretation	84 hr	18.02	1 514
Field mapping/checking	16 hr	18.03	288	Field mapping/checking	16 hr	18.02	288
Data processing:				Data processing:			
Hand tabulating	40 hr	18.02	721	Hand tabulating	40 hr	18.02	721
Total			\$ 2 459	Total			\$ 2 785
Land use updating -- coastal Los Angeles							
Acquiring high-altitude imagery and supporting data sources				Acquiring data sources:			
Purchase of high-altitude photographs	94	\$25.43	\$ 2 390	Low-altitude photographs (existing)			
Purchase of maps	56	.77	43	Purchase	248	\$ 1.87	\$ 464
				Special processing	1	6.00	6
				Purchase of maps	56	.77	43
Data collection and interpretation:				Data collection and interpretation:			
Interpretation	651 hr	18.02	11 731	Interpretation	768 hr	18.02	13 839
Field mapping/checking	24 hr	18.02	433	Field mapping/checking	24 hr	18.02	433
Data processing:				Data processing:			
Preparing data for machine processing	850 hr	11.90	10 115	Preparing data for machine processing	850 hr	11.90	10 115
Machine processing	100	1.00	100	Machine processing	100	1.00	100
Total			\$24 812	Total			\$25 000

^aCosts involving salaries include an overhead cost of 70 percent. ^bTotals are rounded off to the nearest dollar. ^cTotal cost includes special charges not shown in the table.

TABLE III.— Concluded

High-altitude imagery				Conventional data sources			
Function and type of cost	Quantity	Unit cost ^a	Total ^b	Function and type of cost	Quantity	Unit cost ^a	Total ^b
Watershed characterization							
Acquiring high-altitude imagery and supporting data sources				Acquiring data sources			
Purchase of high-altitude photographs	30	\$26.40	\$ 792	Low-altitude photographs (existing)			
Low-altitude support photographs (specially flown)				Purchase	550	\$ 1.51	\$ 832
Flight planning	4 hr	18.03	72	Special processing	1	4.00	4
Contracted services	15 hr	70.00	1 050	Low-altitude photographs (specially flown)			
Film purchase and processing	140 ft	1.22	170	Flight planning	4 hr	18.03	72
Flight observer	15 hr	18.03	^c 340	Contracted services	15 hr	70.00	1 050
Photographer	15 hr	17.70	^c 336	Film purchase and processing	140 ft	1.22	170
Miscellaneous	20 hr	18.02	360	Flight observer	15 hr	18.03	^c 340
Purchase of maps	22	10.33	227	Photographer	15 hr	17.70	^c 336
				Miscellaneous	20 hr	18.02	360
				Purchase of maps	22	10.33	227
Data collection and interpretation:				Data collection and interpretation:			
Interpretation	25 hr	18.02	451	Interpretation	50 hr	18.02	901
Field mapping/checking	60 hr	18.02	1 081	Field mapping/checking	60 hr	18.02	1 081
Data processing				Data processing:			
Preparing data for machine processing	16 hr	11.90	190	Preparing data for machine processing	50 hr	11.90	595
Machine processing	100	1.00	100	Machine processing	100	1.00	100
Total			\$ 5 169	Total			\$ 6 068
Waterway mapping							
Acquiring high-altitude imagery and supporting data sources				Acquiring data sources			
Purchase of high-altitude photographs	2	\$42.03	\$ 84	Low-altitude photographs (specially flown)			
Purchase of maps	1	5.25	5	Flight planning	1 hr	\$18.00	\$ 18
				Contracted services	8 hr	70.00	560
				Film purchase and processing	3 ft	1.21	4
				Flight observer	8 hr	18.02	144
				Photographer	8 hr	17.70	142
				Miscellaneous	1 hr	18.00	18
				Purchase of maps	1 hr	5.25	5
Data collection and interpretation:				Data collection and interpretation:			
Interpretation	46 hr	5.10	235	Interpretation	46 hr	5.10	235
Miscellaneous	5	10.00	50	Miscellaneous	5	10.00	50
Total			\$ 374	Total			\$ 1 176
Flood damage assessment							
Acquiring high-altitude imagery and supporting data sources				Acquiring data sources			
High-altitude photographs				Low-altitude photographs (specially flown)			
Purchase	1	\$60.05	\$ 60	Flight planning	8 hr	\$18.02	\$ 144
Special processing	1	\$1.00	1	Contracted services	—	—	766
Maps				Maps			
Purchase	12	.75	9	Purchase	12	.75	9
Preparation	1 hr	18.02	18	Preparation	1 hr	18.02	18
Data collection and interpretation:				Data collection and interpretation:			
Interpretation	24 hr	18.02	432	Field surveying	344 hr	13.60	^c 5 688
				Data processing			
				Hand tabulating	16 hr	18.02	288
Total			\$ 575	Total			\$ 6 913

^aCosts involving salaries include an overhead cost of 70 percent. ^bTotals are rounded off to the nearest dollar. ^cTotal cost includes special charges not shown in the table.

(table II) does not reflect the fact that the CIR U-2 imagery has greater utility for a variety of mapping purposes than the black-and-white imagery. As a result, it is expected to become relatively more cost effective with time as other uses are found for it.

A minor disadvantage in using this imagery (which also slightly increases its cost) is in having to cut the roll film into 9- by 18-inch images and protect the images with a clear plastic cover for use in an overhead projector. Also, the 9- by 18-inch format created storage problems and resulted in rougher handling and consequently more damage to photographs than was experienced with the contact panchromatic photographs.

A mapping task that could not be accomplished as well on the CIR U-2 imagery as on the black-and-white was the separating of urban areas from areas of native vegetation. This same condition also was observed in the urban boundary study except that color imagery, rather than black-and-white imagery, provided the greater contrast.

Watershed Characterization

Introduction.- The costs of using U-2 imagery for extracting a variety of resource conditions in the Van Duzen River watershed in the north coastal area of California were compared to the costs of using conventional panchromatic photographs for such mapping. The department, in cooperation with the Planning Department of Humboldt County, undertook an environmental mapping study of more than 430 square statute miles of the watershed as a preliminary step in developing a management plan for the river. Land features of interest were new roads, vegetative types, land uses, river characteristics, structures, et cetera. Costs associated with using the U-2 and panchromatic photographs are detailed in table III.

Procedure.- The imagery used in the study was 1:32 500-scale, 9- by 18-inch CIR U-2 transparencies and commercial 1:12 000 panchromatic 9- by 9-inch contact prints flown for Humboldt County. In addition, 35-millimeter color slides of the upper 60 percent of the watershed were taken as an aid in interpreting data from both sets of imagery. The U-2 transparencies were projected onto 1:24 000-scale base maps and the various land features delineated on them. The 1:12 000-scale panchromatic photographs were similarly projected onto the base maps. The 35-millimeter color imagery was

projected onto a screen and used to develop signatures for various land features on both sets of photographs and to help make mapping decisions in complex areas. Approximately 2 hours of field checking the interpreted data was done for each base map (approximately 62 square statute miles). Data processing consisted of preparing from the work maps a complete set of maps for publication.

Discussion.- The 20-percent higher costs associated with the use of panchromatic photographs was caused almost entirely by the extra time involved in handling 550 photographs compared to 30 U-2 photographs. Most of this handling time consisted of projector adjustments to normalize photographic scale to map scale. Because the study was conducted in an area with much contrasting relief, it was not uncommon to make several adjustments for each photograph. In using the U-2 photographs, it was seldom necessary to make further adjustments after the initial photograph-to-map match.

Also adding to the difficulty of using the contact prints was the considerable image "falloff" around the photograph edges which reduced the usable area of the photograph and further increased the handling (interpretation) time. This was not a problem with the U-2 photographs, in which the scale appeared generally uniform and free of distortion.

Another, although minor, advantage of the U-2 imagery became apparent in areas with few landmarks to which the photographs could be oriented. The greater areas covered by the U-2 photographs provided more opportunities for locating landmarks and for reducing the handling time.

A major disadvantage of the U-2 imagery was the variability in quality. Images varied from washed out to overly saturated and many exhibited light "falloff" around the edges. As a result, the 35-millimeter color transparencies had to be used on occasion to help interpret land features.

Except for the 35-millimeter use previously discussed, the 35-millimeter color slides generally were not of much value as a supplemental aid to either U-2 or black-and-white photographs. The severe relief and low altitude of exposure (5000 feet above mean ground elevation) combined to provide so much image distortion as to make them virtually useless for locating boundaries accurately. Even at twice the altitude, the usefulness of the imagery for this purpose would be questionable. The exception would be the relatively flat areas along rivers, where such imagery could be used to good advantage.

REPRODUCIBILITY OF THE
ORIGINAL PAGE IS POOR

Waterway Mapping

Introduction.- The costs of using U-2 imagery for preparing a map of the Eel River delta in northern California were compared to the costs of using 35-millimeter color photographs. The new map was desired by fish and game specialists evaluating wildlife habitats in the area for the department. Detailed costs of using the U-2 and 35-millimeter imagery are given in table III.

Procedure.- Two 9- by 18-inch CIR high-altitude transparencies at 1:32 500 scale were used for the study. In the absence of current conventional photography, 35-millimeter color transparencies were obtained of the area from an elevation of approximately 7000 feet. The U-2 transparencies were vertically projected onto a 1:24 000-scale U.S. Geological Survey (USGS) quadrangle and changes in the waterways posted to the map. The 35-millimeter slides were horizontally projected onto a wall-mounted base map, and changes were posted. No field work was required for either technique. Data processing in each case consisted of drafting the corrected map onto a clean base, hand coloring, and obtaining photographic reproductions.

Discussion.- Both film formats proved satisfactory for accomplishing the study. However, the much greater cost of acquiring the 35-millimeter color slides probably would rule out this alternative in most cases.

One of the side benefits noticed in using the U-2 CIR film was its capability to more sharply depict the water/land interface than was possible with the color film. This advantage, while noticeable during the interpretation phase, had no appreciable effect on the accuracy of the finished maps.

Flood Damage Assessment

Introduction.- The costs of using U-2 imagery for mapping flood damage in Butte Basin in the center of the Sacramento Valley were compared to the costs using specially flown commercial panchromatic film. The data were needed in anticipation of flood damage litigation. The detailed costs of using the single U-2 photograph and the costs for using the panchromatic film are included in table III.

Procedure.- The U-2 imagery selected was a single 9- by 18-inch, 1:32 500-scale CIR transparency. The

conventional imagery was specially flown 1:24 000-scale panchromatic photographs.

In order to delineate flooded or flood-damaged areas on the U-2 photograph, it was necessary to enlarge it. Half of the photograph, which adequately covered the basin, was photographically enlarged to 1:24 000 scale. Delineations were accomplished directly on the image without any field checking. The 9- by 9-inch, 1:24 000-scale black-and-white photographs were taken to the field by survey crews and used for locating damaged areas and for recording the damages. The data on the photographs were then transferred to a set of 1:24 000-scale base maps.

Discussion.- Because of the importance of precisely locating flood boundaries for litigation purposes and because timely conventional imagery is usually uncontrolled and not suitable for this purpose, the traditional technique has been to send survey crews out within a couple of days of a flood to survey the boundaries. As the cost figures demonstrate, this is an expensive procedure.

The comparison of field survey results with the results achieved by interpreting the enlarged U-2 image revealed essentially no difference in the boundaries. In fact, boundaries that could not be clearly located on the conventional photographs or by the survey crews because of difficult access or other reasons often were visible on the U-2 photographs. Some of this capability is due to the greater sensitivity of CIR film to subtle soil moisture and vegetative conditions. However, the greater uniformity and integrity of the U-2 image compared to the 1:24 000-scale photographs also appeared to contribute to its greater usefulness.

Although no attempt was made to quantify the accuracy of the two mapping schemes, the results indicate that flood damage mapping on U-2 imagery of the flat Central Valley may be done with sufficient accuracy to eliminate much of the need for field survey data.

Another advantage noted in using the U-2 image was that it provided an instant view of the entire Butte Basin. By contrast, the collective view of the many panchromatic photographs covers an elapsed time of about an hour, the time required to fly them. It was believed that this unique capability might prove useful in some rare instance to ensure against confusion as to the sequence of flood events that could result if a significant event were to occur at some unknown time during the photographic flight mission. An instant view might not be as likely to raise such questions.

SATELLITE IMAGERY APPLICATIONS

In contrast to the high-altitude imagery applications that the department has been able to evaluate with existing equipment, materials, and expertise under ongoing programs, the satellite imagery applications of interest to the department cannot be fully explored with existing resources. For this reason, we are relying on the research community to assist us in such studies.

The nature of this research assistance is quite varied, including a nonfunded student project, informal and formal cooperative agreements with a number of university researchers, a fully funded NASA project, and a partially funded NASA project involving a private research institute. Only the formal studies are reported here.

Some of the informal cooperative studies have been going on more than 3 years, but the formal studies have just been initiated. The following discussions report on the status of the formal studies and the department's experience in preparing a photomosaic.

Irrigated Lands Study

The irrigated lands study is a NASA-funded Landsat-2 project with the University of California acting as the contractor. The experiment will investigate the feasibility of using Landsat-2 imagery for inventorying and monitoring irrigated lands in California. The Remote Sensing Research Program of the University of California, working through the university's Space Sciences Laboratory and in cooperation with the Department of Water Resources, will investigate the extent to which the desired data can be extracted from the Landsat-2 imagery, supplemented with supporting aircraft and ground information.

The primary object of the research is the development of an operationally feasible process whereby Landsat-2 satellite imagery can be used to provide periodic irrigated land acreage statistics for the whole state and for individual counties. To fulfill this objective, the investigation will necessarily involve the development of efficient techniques for (1) interpreting sequential imagery covering an area of more than 10 million acres, (2) sampling this area through the use of satellite imagery, supporting aerial photography, and ground data, (3) converting the interpretation results into usable statistics, and (4) evaluating the end product in terms of the costs and/or resources required for its acquisition, and also in terms of its accuracy and timeliness.

The project is still in its formulative stage. Several meetings have been held with the research personnel to design the sampling network, develop processing techniques, assign ground data collection responsibilities, et cetera.

Snow Cover Observations

The snow observations study is a fully funded NASA investigation with the department acting as the contractor. It is a 5-year study designed to develop an operational program for incorporating satellite observations of snow cover into the hydrologic forecasting program of the department.

Imagery from two satellite systems (Landsat and NOAA) and U-2 overflights will be combined with ground data during the data reduction and analysis phases. This program also is in its early stages with no results to report at this time.

Water Quality Study

An 18-month NASA study on water quality involves the department, the State Water Resources Control Board, and the Stanford Research Institute (SRI), a private corporation. The department is the contractor.

The objective of this investigation is to determine, by systematic analysis, the choices of aerial observation systems and surveillance altitudes that are most likely to detect distinct classes of water quality problems. Water quality data and imagery obtained from Landsat and high-altitude aircraft will be compared with new ground truth and existing data to determine the relative value of information collected by each mode of remotely sensed data. The investigation will involve two sites, the San Francisco Bay-Delta area and the Lake Tahoe area.

Most of the analysis work will be done by the SRI using a complex of electronic devices collectively termed an "Electronic Satellite Image Analysis Console." Department personnel will work closely with SRI personnel during the analysis phase. The department and the State Water Resources Control Board will share equally in collecting the ground data needed by SRI.

Color-Infrared Photomosaic of California

Although not really a research effort, the preparation of a CIR photomosaic of the state was our first real

involvement in using satellite imagery. The department prepared the mosaic for educational and display purposes. It has received wide distribution both inside and outside the department and has proved to be a very effective device for stimulating interest in remote-sensing capabilities.

The technique used for enhancing the 32 Landsat-1 images that made up the mosaic was to triple-expose bands 4, 5, and 7 (one at a time with its appropriate color filter) on a single frame of colored film. Positive 9.5- by 9.5-inch transparencies were selected for the project and photographed with an 8- by 10-inch copy camera on a 1:1 basis. Densitometer readings of the gray scale of each image were taken to set exposure.

This procedure produced color prints that could be mosaicked together without any additional adjustments. No problems were experienced in matching the prints to a 1:1 000 000-scale state base map.

The major problem encountered was an inability to produce a true gray scale on the color print. The gray scale was desired so that continuity of color hue could be maintained on images of a particular orbit. This problem resulted from a number of factors but primarily from inexperience and will be resolved with time.

CONCLUSIONS

The California Department of Water Resources has been and plans to remain an active participant in the investigation of remote-sensing capabilities. Our initial interest in the technology of "new remote sensing" naturally developed from an implied organizational dictum to continually seek new ways of acquiring more as well as better data, preferably at no increase in cost and hopefully at a decrease. This initial interest was heightened by the gradual realization on our part that high-altitude and space imagery also may permit us to

acquire certain kinds of data in which we have had a longtime interest but which, up to now, we have considered either impossible or impracticable to collect.

Our vicarious involvement in this new art-science has now given way to active involvement. With some experience in testing remote-sensing capabilities and in reviewing the work of others, we are beginning to replace our uncertainty about this new planning tool with knowledge of some positive benefits.

One of these benefits, as shown by our U-2 cost-effectiveness comparisons reported here, is the substantial savings that could be immediately realized in many of our programs if U-2 imagery were available on a timely, operational basis. Also, preliminary results of cost-effectiveness studies by personnel of the Remote Sensing Laboratory, University of California, Berkeley, comparing satellite to conventional data sources (one of the informal cooperative studies) are showing some dramatic savings in acquiring water supply information.

In the area of data quality improvement, our U-2 application studies revealed many possibilities for improving data quality without any sacrifice of data quantity or without increases in costs. In future studies, we will attempt to quantify quality aspects, particularly those relating to accuracy.

Because we recognize that these demonstrated remote-sensing applications cannot be implemented or sustained with experimental remote-sensing platforms, we have no intention of abandoning the conventional remote-sensing techniques that have worked so well for us in the past. However, where research results clearly indicate that cost-effective remote-sensing applications exist that can achieve superior results or provide needed but previously unavailable data, we will continue to help achieve the technology transfer of such applications and to support plans for establishment of operational remote-sensing platforms to make them operational realities.